

# Test & Measurement product catalog

13



A Greater Measure of Confidence

**KEITHLEY**  
A Tektronix Company

# Digital Multimeters and Systems

## Selector Guide

**2110**

**2100**

**2000**

**2001**

**2002**

**2010**

**2015**

**2015-P**

**2016**

**2016-P**

## Series 3700A

**2700**

**2701**

**2750**

## Selector Guide

## Free Software

**2790**

**7751**

**7752**

**7753**

Technical Information . . . . . 230

Digital Multimeters . . . . . 232

5½-Digit Dual-Display Digital Multimeter . . . . . 234

6½-Digit USB Digital Multimeter . . . . . 238

6½-Digit Multimeter . . . . . 242

High Performance 7½-Digit Multimeter . . . . . 247

High Performance 8½-Digit Multimeter . . . . . 247

Low Noise 7½-Digit Autoranging Multimeter . . . . . 253

6½-Digit THD Multimeter . . . . . 255

6½-Digit Audio Analyzing Multimeter . . . . . 255

6½-Digit THD Multimeter w/9V Source Output . . . . . 255

6½-Digit Audio Analyzing Multimeter  
w/9V Source Output . . . . . 255

System Switch/Multimeter and Plug-In Cards . . . . . 263

Multimeter/Data Acquisition System . . . . . 264

Ethernet DMM/Data Acquisition System . . . . . 264

Multimeter/Switch System . . . . . 264

Plug-In Modules for Integra Systems . . . . . 273

Plug-In Modules and Accessories  
for Integra Systems . . . . . 273–285

Free Bundled Software . . . . . 286

ExceLINX™ -1A Excel Add-In . . . . . 287

SourceMeter® Airbag Test System . . . . . 288

High Voltage Source/Switch Module . . . . . 293

Low Voltage, Current-Source-Only  
Source/Switch Module . . . . . 293

1MΩ High Voltage Source/Switch Module . . . . . 293

# Technical Information

Digital multimeters convert analog signals to digital information. In general, DMMs have a minimum of five typical functions. They are DC voltage, AC voltage, DC current, AC current, and resistance. While specifications vary, most DMMs can be described with block diagrams similar to **Figure 1**.

## Analog to Digital Conversion

The A/D converts the analog input signal to a digital output and is primarily responsible for key instrument characteristics of reading speed, linearity, resolution, normal mode rejection, and precision. The digital output is shown or obtained in several ways. One way is visually, via the front panel with a display of digits and other information. Another way is electronically, with results sent via a port (GPIB, RS-232, USB, or Ethernet) to a computer for further processing.

## Resolution

Resolution is defined as the smallest detectable change on any range referenced to full scale. For example, if an instrument displays a maximum of 19,999 on any range, and the smallest detectable change in the input signal is  $\pm 1$  least significant digit (LSD), then the resolution is  $1/19999$  or 0.005%.

Resolution is commonly expressed as a whole number plus a fraction, e.g.,  $5\frac{1}{2}$  digits. The whole number represents the number of digits that can display the numbers from 0 to 9. The fraction indicates that the most significant digit has one or more non-zero states, that is, it can display 0, 1, or 2.

## Sensitivity

Sensitivity is similar to resolution in that it deals with the smallest change of the input signal the instrument can detect. However, sensitivity is not referenced to full scale, so it is expressed in absolute terms and applies to the lowest range on any function. The sensitivity of a  $7\frac{1}{2}$ -digit DMM is 10nV if its lowest measurement range is 200mV.

## Accuracy

Accuracy is specified as a two-term specification:  $\pm(\% \text{ of reading} + \% \text{ of range})$  or as (ppm of reading + ppm of range). The closer to zero on the range that the percent of range term of the specification is, the greater the weight it has in the accuracy calculation. The closer to full scale on the range the percent of reading term of the specification is, the greater the weight it has in the accuracy calculation. The best accuracy is obtained near full scale.

# Digital Multimeters

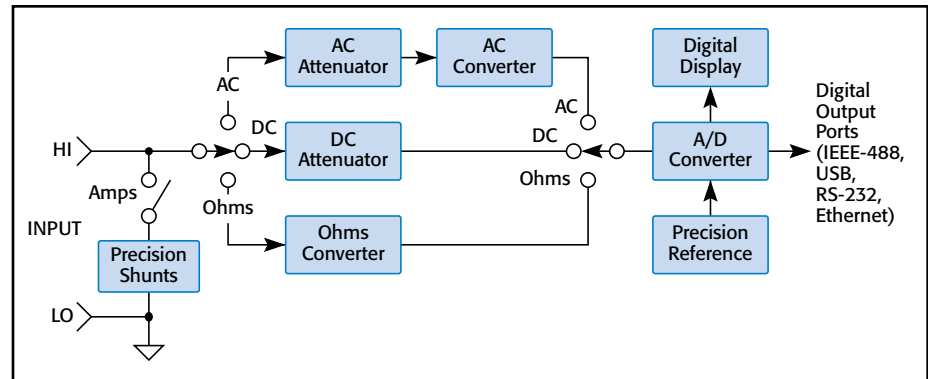

**Figure 1: DMM Block Diagram**

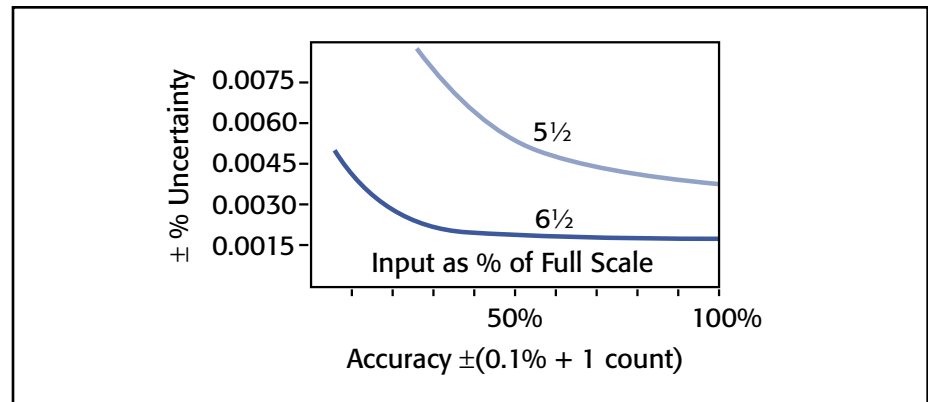

**Figure 2: Expected Reading Uncertainty:  $5\frac{1}{2}$ - vs.  $6\frac{1}{2}$ -Digit DMMs**

Accuracy is also generally stated under several conditions, including  $\pm 1^\circ\text{C}$ ,  $\pm 5^\circ\text{C}$  operating temperature, and 24-hour, 90-day, and one-year calibration intervals. The expected accuracy can be improved by controlling temperature variations in the environment and by electing more frequent calibration intervals. **Figure 2** illustrates the effect on accuracy at various levels of input signal within the measurement range. Accuracy for both meters is specified at  $\pm(0.1\% + 1 \text{ count})$ .

## Loading and Input Impedance

Loading is the disturbance to the circuit being measured caused by the finite input impedance of the DMM. Input impedance is the equivalent resistance and capacitance of the input terminals of the DMM.

**Loading error** (**Figure 3**) is the difference between the voltage measured by the meter ( $V_M$ ) and the voltage of an ideal source ( $V_S$ ).

**Voltage burden error** (**Figure 4**) is the difference between the expected current through the load ( $R_L$ ) and the measured current ( $I_M$ ) caused by the finite voltage drop of the measuring instrument.

## Two-Wire vs. Four-Wire Ohms

Two-terminal DMMs source test current through the measuring test leads, terminating at the HI-LO inputs of the DMM. This two-wire ohms system works fine for most resistance measurement applications. However, the I-R drop in the test leads ( $R_L$ ) can cause inaccuracies that become apparent in lower resistance measurements (**Figure 5**).

Four-wire ohms or Kelvin measurements bypass the voltage drop across  $R_L$  by bringing two high impedance voltage sense leads out to the unknown  $R_X$ . There is very little current in the sense circuit because of the high input impedance, so there's effectively no I-R drop in the leads, and the voltage seen by the sense

1.888.KEITHLEY (U.S. only)

[www.keithley.com](http://www.keithley.com)

**KEITHLEY**

A Tektronix Company

A Greater Measure of Confidence

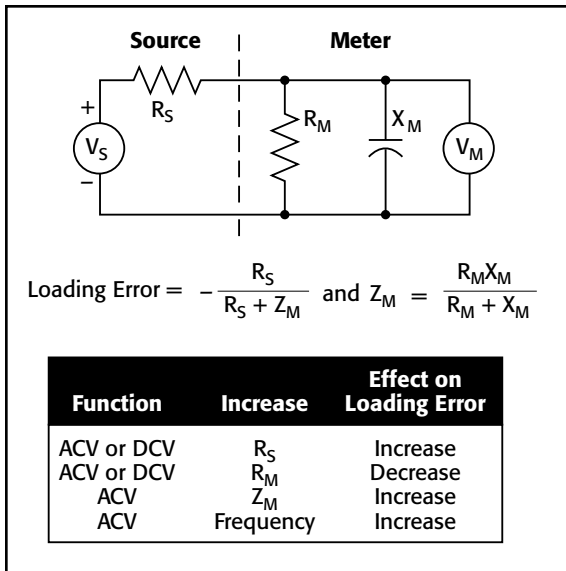

Figure 3: Loading Error

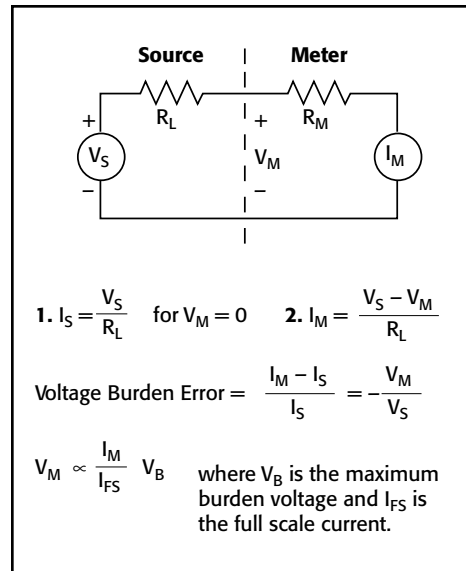

Figure 4: Voltage Burden Error

terminals is the same as the voltage developed across  $R_X$ .

### Speed and Settling Time

Every meter has a settling time associated with its input circuit. The reading rates or measurement speeds of instruments are independent of the settling times. For high resolution meters, it may be necessary to allow time for input settling to achieve full rated accuracy.

Several parameters affect measurement speed, including integration rate (NPLC), filter setting, ranging, AutoZero, trigger delays, and display settings. For maximum measurement speed, set these parameters:

- Integration rate = 0.01
- Filter = disabled
- Range = fixed (no auto range)
- AutoZero = disabled
- Trigger Delay = 0.0
- Display = disabled

Note that maximum speed settings do not produce the greatest accuracy.

### Normal and Common Mode Rejection

Normal mode interference is the interference mixed in with the incoming signal. Most normal mode interference is at line frequency and its harmonics. *NMRR* (Normal Mode Rejection Ratio) is specified in dB at line frequencies of 50Hz and 60Hz. Normal mode interference is detected as a peak noise or deviation in a DC signal.

$$NMRR = 20 \log \frac{(\text{peak measurement deviation})}{(\text{peak normal mode interference})}$$

*CMRR* (Common Mode Rejection Ratio) specifies the ability of a meter to reject signals common to both input HI and LO. This term is generally measured with a 1k $\Omega$  imbalance in one of the leads. A larger imbalance will cause CMRR to be worse. CMRR is specified at DC, 50Hz, or 60Hz, and (like NMRR) is expressed in dB. CMRR applies to both DC and AC measurements and appears as an offset error to the desired signal.

### Overload Protection

This is a measure of electrical ruggedness and should be sufficient to protect the meter from commonly encountered line voltages. Typically, the ranges most susceptible to high voltage are the lowest voltage range (e.g., 100mV) and the

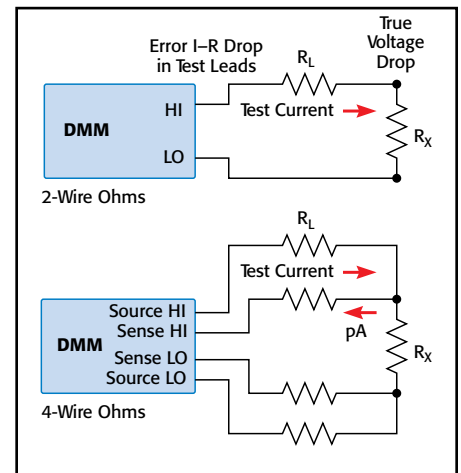

Figure 5: 2-Wire vs. 4-Wire Ohms

ohms ranges. Similar to overload protection is the maximum common mode voltage at which the meter can be used. This is the maximum voltage from earth ground that the input LO or COMMON terminal can withstand safely. The input terminal should always be at the lowest impedance.

# Selector Guide Digital Multimeters

Model	2110	2100	2000	2010	2001	2002
Page	234	238	242	253	247	247
Digits	5½	6½	6½	7½	7½	8½
Expansion Channels	N/A	N/A	10	10	10	10
<b>DC Volts</b>						
Sensitivity	1 µV	0.1 µV	100 nV	10 nV	10 nV	1 nV
Maximum Reading	1000 V	1000 V	1000 V	1000 V	1100 V	1100 V
Basic Accuracy	0.012%	0.0038%	0.002%	0.0018%	0.0018%	0.0006%
Ratio		•		•	Option	Option
DC Peak Spikes					•	•
<b>AC Volts (TRMS)</b>						
Sensitivity	1 µV	0.1 µV	100 nV	100 nV	100 nV	100 nV
Maximum Reading	750 V	750 V	750 V	750 V	775 V (1100 V pk)	775 V (1100 V pk)
Basic Accuracy	0.12%	0.08%	0.05%	0.05%	0.03%	0.02%
Bandwidth	10 Hz–300 kHz	3 Hz–300 kHz	3 Hz–300 kHz	3 Hz–300 kHz	1 Hz–2 MHz	1 Hz–2 MHz
dB, dBm		•	•	•	•	•
Frequency, Period	•	•	•	•	•	•
Peak/Avg/RMS	RMS	RMS			•	•
AC, AC + DC	AC	AC			•	•
<b>Ohms (2/4 Wire)</b>						
Sensitivity	1 mΩ	100 µΩ	100 µΩ	1 µΩ	1 µΩ	100 nΩ
Maximum Reading	100 MΩ	100 MΩ	120 MΩ	120 MΩ	1 GΩ	1 GΩ
Basic Accuracy	0.02%	0.015%	0.008%	0.0032%	0.0032%	0.0007%
Continuity Test	•	•	•	•		
Diode Test	•	•	•	•		
Offset Compensation				•	•	•
Dry Circuit				•		
Constant Current	•	•	•	•	•	•
Open Source Detect						•
<b>DC Amps</b>						
Sensitivity	0.1 µA	10 nA	10 nA	1 nA	10 pA	10 pA
Range Span	10 mA–10 A	10 mA–3 A	10 mA–3 A	10 mA–3 A	200 µA–2 A	200 µA–2 A
Basic Accuracy	0.15%	0.055%	0.03%	0.03%	0.03%	0.027%
In Circuit Current					•	•
<b>AC Amps (TRMS)</b>						
Sensitivity	10 µA	1 µA	1 µA	1 µA	100 pA	100 pA
Range Span	1 A–10 A	1 A–3 A	1 A–3 A	1 A–3 A	200 µA–2 A	200 µA–2 A
Basic Accuracy	0.3%	0.15%	0.1%	0.1%	0.1%	0.1%
Bandwidth	10 Hz–5 kHz	3 Hz–5 kHz	3 Hz–5 kHz	3 Hz–5 kHz	20 Hz–100 kHz	20 Hz–100 kHz
<b>General Features</b>						
Interface	USB, GPIB (opt.)	USB	GPIB, RS-232	GPIB, RS-232	GPIB	GPIB
Reading Hold	•	•	•	•		
Digital I/O	Trigger In/Out	•			•	•
Reading Memory	2000 rdg.	2000 rdg.	1024 rdg.	1024 rdg.	Opt to 30,000	Opt to 30,000
Maximum Speed	50K rdg/s	2000 rdg/s	2000 rdg/s	2000 rdg/s	2000 rdg/s	2000 rdg/s
Temperature Meas.	T/C, RTD, Thermistor	RTD	T/C	T/C, RTD	T/C, RTD	T/C, RTD
Language Emulation		34401A	8840/42, 196/199	196/199		HP 3458

1.888.KEITHLEY (U.S. only)

[www.keithley.com](http://www.keithley.com)

**KEITHLEY**

A Greater Measure of Confidence

A Tektronix Company

# Selector Guide

# Digital Multimeters

Model	3706A	2015, 2016	2700	2701	2750
Page	263, 162	255	264	264	264
Digits	7½	6½	6½	6½	6½
Expansion Channels	576		80	80	200
<b>DC Volts</b>					
Sensitivity	10 nV	100 nV	100 nV	100 nV	100 nV
Maximum Reading	300 V	1000 V	1000 V	1000 V	1000 V
Basic Accuracy	0.002%	0.002%	0.002%	0.002%	0.002%
Ratio			w/MUX card	w/MUX card	w/MUX card
DC Peak Spikes					
<b>AC Volts (TRMS)</b>					
Sensitivity	100 nV	100 nV	100 nV	100 nV	100 nV
Maximum Reading	300 V	750 V	750 V	750 V	750 V
Basic Accuracy	0.05%	0.05%	0.06%	0.06%	0.06%
Bandwidth	3 Hz–300 kHz	3 Hz–300 kHz	3 Hz–300 kHz	3 Hz–300 kHz	3 Hz–300 kHz
dB, dBm	•	•			
Frequency, Period	•	•	•	•	•
THD, Harmonics		20 Hz–20 kHz			
Spectrum Peaks		-P versions			
Sine Source		4V/9V (10 Hz–20 kHz)			
<b>Ohms (2/4 Wire)</b>					
Sensitivity	100 nΩ	100 μΩ	100 μΩ	100 μΩ	1 μΩ
Maximum Reading	100 MΩ	120 MΩ	120 MΩ	120 MΩ	120 MΩ
Basic Accuracy	0.004%	0.008%	0.008%	0.008%	0.008%
Continuity Test	•		•	•	•
Diode Test		•			
Offset Compensation	•	•	•	•	•
Dry Circuit	•				•
Constant Current	•	•	•	•	•
<b>DC Amps</b>					
Sensitivity	1 pA	10 nA	10 nA	10 nA	10 nA
Range Span	10 μA–3 A	10 mA–3 A	20 mA–3 A	20 mA–3 A	20 mA–3 A
Basic Accuracy	0.03%	0.03%	0.03%	0.03%	0.03%
<b>AC Amps (TRMS)</b>					
Sensitivity	1 nA	1 μA	1 μA	1 μA	1 μA
Range Span	1 mA–3 A	1 A–3 A	1 A–3 A	1 A–3 A	1 A–3 A
Basic Accuracy	0.08%	0.1%	0.15%	0.16%	0.15%
Bandwidth	3 Hz–10 kHz	3 Hz–5 kHz	3 Hz–5 kHz	3 Hz–5 kHz	3 Hz–5 kHz
<b>General Features</b>					
Interface	GPIO, LXI/Ethernet, USB	GPIO, RS-232	GPIO, RS-232	Ethernet, RS-232	GPIO, RS-232
Reading Hold		•	•	•	
Digital I/O	14	2 in/5 out (TTL)	2 in/5 out (TTL)		
Reading Memory	650,000 rdg.	1024 rdg.	55,000 rdg.	450,000 rdg.	110,000 rdg.
Maximum Speed	>14,000 rdg/s	2000 rdg/s	2000 rdg/s	3500 rdg/s	2500 rdg/s
Temperature Meas.	T/C, RTD, Thermistor	T/C	T/C, RTD, Thermistor	T/C, RTD, Thermistor	T/C, RTD, Thermistor

1.888.KEITHLEY (U.S. only)

[www.keithley.com](http://www.keithley.com)

A Greater Measure of Confidence

**KEITHLEY**

A Tektronix Company

Single-slot, large format switch system

DIGITAL MULTIMETERS & SYSTEMS

**2110**

# 5½-Digit Dual-Display Digital Multimeter



The Model 2110 5½-Digit Dual-Display Digital Multimeter combines a compelling price with a comprehensive set of capabilities, superior measurement accuracy, and high speed for a broad range of applications. It features 15 measurement functions and 7 math functions and has dual-line display capability, which allows it to display two different measurements concurrently. The Model 2110 is an unbeatable value for production, R&D, and test engineers, scientists, and students making a wide variety of measurements in portable, bench, and system applications.

## High Accuracy, Abundant Capabilities, Low Cost

The Model 2110 provides precision and a rich set of capabilities at a value price. It has 0.012% one-year basic DC voltage accuracy and 0.020% one-year basic resistance accuracy up to the 100kΩ range.

The Model 2110 provides a wide number of measurement ranges and functions:

- DC voltage: 0.1V, 1V, 10V, 100V, and 1000V
- AC voltage: 0.1V, 1V, 10V, 100V, and 750V
- DC current: 10mA, 100mA, 1A, 3A, and 10A
- AC current: 1A, 3A, and 10A
- Two- and four-wire resistance: 100Ω, 1kΩ, 10kΩ, 100kΩ, 1MΩ, 10MΩ, and 100MΩ
- Frequency: From 10Hz to 300kHz
- Capacitance measurement: 1nF, 10nF, 100nF, 1μF, 10μF, 100μF
- Thermocouple measurement: J-, R-, S-, T-, E-, N-, B-, C-, and K-type thermocouples
- Temperature (RTD and NTC Thermistor) measurements
- Diode measurement
- Continuity test
- Programmable A-D converter and filter settings for signal to noise optimization. Additionally, seven mathematical operations can be performed on measurement readings: percentage, average, min/max, NULL, limits, mX+b, dB, and dBm testing.

## Speed

At 5½ digits, the Model 2110 delivers up to 200 readings/s via the USB remote interface. At the fast 4½-digit setting, it reads up to 50,000 readings/s and up to 30,000 readings/s into the buffer, making it ideal for production and monitoring applications in which speed is critical.

- High accuracy, high speed for general purpose measurements
- 15 measurement functions, including capacitance and thermocouple measurements
- Dual-line display allows concurrent measurements
- TMC-compliant USB 2.0 interface for use with SCPI test commands
- GPIB option for use in system applications
- Includes PC software utilities for graphing and data sharing in both Microsoft® Word and Excel
- Rugged construction for durability in bench/portable applications
- Includes all accessories, such as start-up software, USB cable, power cable, and safety test leads
- CE compliant and  US listed

## APPLICATIONS

### Built for Production Testing

The Model 2110 Digital Multimeter is ideal for applications in manual, semi-automatic, and automatic testing of low-cost electronic devices, circuits, modules, electrical components, and semiconductor components. Key features include:

- **Speed: up to 50,000 readings per second**
- **Control: GPIB (optional) and USB interfaces, accepting SCPI (IEEE-488.2) commands**
- **External BNC trigger lines**
- **NIST traceability (with included calibration certificate)**

### Built for General Purpose Uses

The Model 2110 Digital Multimeter is also ideal for bench uses such as research, development, service, calibration, and teaching. Bench-oriented features include:

- **Accuracy: 0.012% basic DCV accuracy**
- **Easy-to-operate panel**
- **Easy waveform plotting and data collection with KI-Tool and KI-Link**
- **Store up to 2000 readings**

1.888.KEITHLEY (U.S. only)

[www.keithley.com](http://www.keithley.com)

A Greater Measure of Confidence

A Tektronix Company

# 2110

## 5½-Digit Dual-Display Digital Multimeter

### Ordering Information

2110-100: 5½-digit USB Digital Multimeter (100V)

2110-120: 5½-digit USB Digital Multimeter (120V)

2110-220: 5½-digit USB Digital Multimeter (220V)

2110-240: 5½-digit USB Digital Multimeter (240V)

2110-100-GPIB: 5½-digit USB and GPIB Digital Multimeter (100V)

2110-120-GPIB: 5½-digit USB and GPIB Digital Multimeter (120V)

2110-220-GPIB: 5½-digit USB and GPIB Digital Multimeter (220V)

2110-240-GPIB: 5½-digit USB and GPIB Digital Multimeter (240V)

### Accessories Supplied

Reference Manual on CD, Specifications, LabVIEW® Driver, Keithley I/O Layer, USB Cable, Power Cable, Safety Test Leads, KI-Tool, and KI-Link Add-in (both Microsoft Word and Excel versions), Calibration Certificate



All accessories, such as start-up software, USB cable, power cable, and safety test leads, are included with the Model 2110.

### Simplicity

The Model 2110 is operational and intuitive to use right out of the box. The functions on the front panel are user friendly and easy to read. Its KI-Tool and KI-Link software allow users to quickly control the instrument over GPIB (if equipped) or USB, record measurements, and display time-series plots of the data. Its LabView® and IVI drivers give more-advanced customers even more control over the instrument. Both the TMC-compliant USB remote interface and the GPIB interface allow easy re-use of existing SCPI programs.

### Startup Software, PC Utilities Included

The KI-Tool application provides charting and graphing capabilities without programming to simplify setup, checkout, and basic measurement applications requiring graphical data representation. Scale, offset, and level can be adjusted to fine-tune images for visual evaluation of signal and noise elements over time. It also includes tabular data and SCPI command prompt windows for maximum flexibility. Data sets can also be saved to disk files.

The Microsoft Excel Add-In utility is also included and provides quick data import into a standard Microsoft Excel spreadsheet, including selectable graphing, instrument settings, and number of data points collected. Data can then be analyzed through standard or optional Microsoft Excel functions,

including graphical, statistical, and trend charting. A version supporting Microsoft Word is also included for direct data import into reports.

LabView, IVI-C, and IVI-COM drivers are also supplied to allow for increased flexibility in integrating the Model 2110 into new and existing systems and test routines.

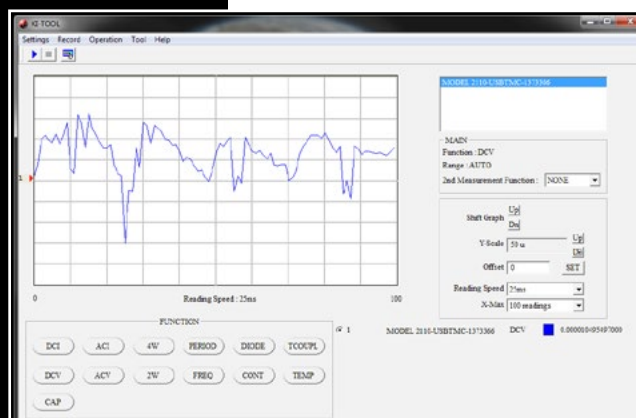

KI-Tool simplifies basic measurement applications through every setup and graphical data representation.

1.888.KEITHLEY (U.S. only)

[www.keithley.com](http://www.keithley.com)

A Greater Measure of Confidence

**KEITHLEY**

A Tektronix Company

Low-cost 5½-digit DMM for system, bench, or portable applications

DIGITAL MULTIMETERS & SYSTEMS



## Specifications

## DC CHARACTERISTICS

DC VOLTAGE			Accuracy <sup>1</sup>	Temperature Coefficient
Range	Resolution	Input Resistance	±(% of reading + % of range)	0°–18°C & 28°–40°C
100.000 mV	1 µV	10 MΩ	0.012 + 0.004	0.001 + 0.0005
1.00000 V	10 µV		0.012 + 0.001	0.0009 + 0.0005
10.0000 V	0.1 mV		0.012 + 0.002	0.0012 + 0.0005
100.000 V	1 mV		0.012 + 0.002	0.0012 + 0.0005
1000.00 V	10 mV		0.02 + 0.003	0.002 + 0.0015

DCI (DC CURRENT)			Accuracy <sup>1</sup>	Temperature Coefficient
Range	Resolution	Shunt Resistance	±(% of reading + % of range)	0°–18°C & 28°–40°C
10.0000 mA	0.1 µA	5.1 Ω	0.05 + 0.020	0.005 + 0.002
100.000 mA	1 µA	5.1 Ω	0.05 + 0.010	0.005 + 0.001
1.00000 A	10 µA	0.1 Ω	0.150 + 0.020	0.008 + 0.001
3.0000 A	100 µA	0.1 Ω	0.200 + 0.030	0.008 + 0.001
10.0000 A	100 µA	5 mΩ	0.250 + 0.050	0.008 + 0.001

RESISTANCE <sup>2</sup>			Accuracy <sup>1</sup>	Temperature Coefficient
Range	Resolution	Test Current	±(% of reading + % of range)	0°–18°C & 28°–40°C
100.000 Ω	1 mΩ	1 mA	0.020 + 0.020	0.003 + 0.0005
1.00000 kΩ	10 mΩ	1 mA	0.020 + 0.003	0.003 + 0.0005
10.0000 kΩ	100 mΩ	100 µA	0.020 + 0.002	0.003 + 0.0005
100.000 kΩ	1 Ω	10 µA	0.020 + 0.002	0.003 + 0.0005
1.00000 MΩ	10 Ω	1 µA	0.030 + 0.004	0.005 + 0.0005
10.0000 MΩ	100 Ω	0.1 µA	0.200 + 0.004	0.05 + 0.0005
100.000 MΩ	1 kΩ	0.1 µA	2.000 + 0.005	0.5 + 0.0005

DIODE TEST			Accuracy <sup>1</sup>	Temperature Coefficient
Range	Resolution	Test Current	±(% of reading + % of range)	0°–18°C & 28°–40°C
1.0000V	10 µV	1 mA	0.020 + 0.030	0.002 + 0.0005

CONTINUITY			Accuracy <sup>1</sup>	Temperature Coefficient
Range	Resolution	Test Current	±(% of reading + % of range)	0°–18°C & 28°–40°C
1000Ω	10 mΩ	1 mA	0.020 + 0.020	0.002 + 0.0005

- Specifications valid after two hour warm-up.
  - ADC set for continuous trigger operation.
  - Input bias current <30pA at 25°C.
  - Measurement rate set to 10 PLC.
- Specifications for 4W ohms mode. For 2W ohms, use zero null or subtract lead resistance from displayed reading.
  - Maximum lead resistance 10% of range per lead for 100Ω and 1kΩ ranges; add 1kΩ per lead for all other ranges.

## MEASUREMENT NOISE REJECTION DC (60Hz/50Hz) at 5.5 DIGITS

CMRR: 120dB for 1kΩ unbalance in LO lead.

NMRR: 60dB for line frequency ±0.1%.

TEMPERATURE (THERMOCOUPLE) CHARACTERISTICS		
Thermocouple Type	Range	Accuracy <sup>1</sup> ±°C 1 Year, exclusive of lead accuracy
B	600 to 1800°C	1.5
C	0 to 2300°C	1.5
E	–250 to 1000°C	1.5
J	–200 to 1200°C	1.0
K	–200 to 1350°C	1.0
N	–200 to 1300°C	1.0
R	0 to 1750°C	1.5
S	0 to 1750°C	1.5
T	–250 to 400°C	1.5

- Specifications valid after two hour warm-up;
  - ADC set for continuous trigger operation.

RTD and NTC Thermistor Measurements: Accuracy ±0.8°C, 1 year, exclusive of lead accuracy. PT100, D100, F100, PT385, PT3916, SPRTD (R-Zero, A4, B4, Ax, Bx, Cx, and Dx), NTCT (A, B, and C), and user-definable RTD.

## CAPACITANCE CHARACTERISTICS

Range	Test Current	Accuracy <sup>1</sup> ±(% of reading + % of range) 1 Year, 23° ±5°C
1.000 nF	10 µA	2.0 + 0.80
10.00 nF	10 µA	1.0 + 0.50
100.0 nF	100 µA	1.0 + 0.50
1.000 µF	100 µA	1.0 + 0.50
10.00 µF	100 µA	1.0 + 0.50
100.0 µF	1 mA	1.0 + 0.50

- Specifications valid after two hour warm-up.
  - ADC set for continuous trigger operation.
  - Null enabled.

## ACCESSORIES AVAILABLE

4299-3	Single Rack Mount Kit
4299-4	Dual Rack Mount Kit
4299-7	Fixed Rack Mount Kit
5805	Kelvin Probes, 0.9m (3ft)
5805-12	Kelvin Probes, 3.6m (12ft)
5808	Low Cost, Single Pin, Kelvin Probes
5809	Low Cost, Kelvin Clip Lead Set
6517-TP	Thermocouple Bead Probe (K-Type)
7007-1	Shielded GPIB Cable, 1m (3.3 ft)
7007-2	Shielded GPIB Cable, 2m (6.6 ft)
8605	High Performance Modular Test Leads
8606	High Performance Modular Probe Kit
8680	RTD Probe Adapter
8681	Low Cost RTD

## SERVICES AVAILABLE

2110-3Y-EW	1 Year Factory Warranty extended to 3 years from date of shipment
2110-5Y-EW	1 Year Factory Warranty extended to 5 years from date of shipment
C/2110-3Y-DATA	3 (Z-540-1 compliant) calibrations within 3 years of purchase for Model 2110
C/2110-5Y-DATA	5 (Z-540-1 compliant) calibrations within 5 years of purchase for Model 2110
C/2110-3Y-ISO	3 (ISO-17025 accredited) calibrations within 3 years of purchase for Model 2110
C/2110-5Y-ISO	5 (ISO-17025 accredited) calibrations within 5 years of purchase for Model 2110

1.888.KEITHLEY (U.S. only)

www.keithley.com

KEITHLEY

A Greater Measure of Confidence

A Tektronix Company

## AC CHARACTERISTICS

FREQUENCY AND PERIOD		Accuracy <sup>1</sup>	Temperature Coefficient
Range	Frequency (Hz)	±(% of reading + % of range) 1 Year, 23° ±5°C	0°–18°C & 28°–40°C
100.000 mV to 750.000 V <sup>2</sup>	10–40 40–300k	0.03 0.02	0.002 0.002

ACV (AC TRMS VOLTAGE)			Accuracy <sup>1</sup>	Temperature Coefficient
Range	Resolution	Frequency	±(% of reading + % of range) 1 Year, 23° ±5°C	0°–18°C & 28°–40°C
100.000 mV to 750.000 V <sup>2</sup>	1 μV to 10 mV	10 Hz–20 kHz 20 kHz–50 kHz 50 kHz–100 kHz 100 kHz–300 kHz	0.12 + 0.05 0.25 + 0.05 0.65 + 0.08 5.00 + 0.50	0.01 + 0.01 0.02 + 0.02 0.04 + 0.02 0.2 + 0.02

ACI (AC TRMS CURRENT)			Accuracy <sup>1</sup>	Temperature Coefficient
Range	Resolution	Frequency	±(% of reading + % of range) 1 Year, 23° ±5°C	0°–18°C & 28°–40°C
1.0000 A to 3.00000 A	10 μA to 100 μA	10 Hz–900 Hz 900 Hz–5 kHz	0.30 + 0.06 1.50 + 0.15	0.02 + 0.01 0.02 + 0.01
10.0000 A	100 μA	10 Hz–900 Hz 900 Hz–5 kHz	0.50 + 0.12 2.50 + 0.20	0.02 + 0.01 0.02 + 0.01

- Specifications valid after two hour warm-up.
  - Slow AC filter (3Hz bandwidth).
  - Pure sine wave input greater than 5% of range.
- 750VAC range is limited to 100kHz.

## GENERAL

Input bias current: <30pA at 25°C.  
 Input protection: 1000V all ranges (2W input).  
 AC CMRR: 70dB (for 1kΩ unbalance LO lead).  
 Power Supply: 100V/120V/220V/240V.  
 Power Line Frequency: 50/60Hz auto detected.  
 Power Consumption: 25VA max.  
 Digital I/O interface: USB-compatible Type B connection, GPIB (option).  
 Environment: For indoor use only.  
 Operating Temperature: 0° to 40°C.  
 Operating Humidity: Maximum relative humidity 80% for temperature up to 31°C.  
 Storage Temperature: –40° to 70°C.  
 Operating Altitude Up to 2000 m above sea level.  
 Bench Dimensions (with handles and bumpers): 107 mm high × 252.8 mm wide × 305 mm deep (3.49 in. × 9.95 in. × 12.00 in.).  
 Weight: 2.23 kg ( 4.92 lbs.).  
 Safety: Conforms to European Union Low Voltage Directive, EN61010-1. Measurement Cat I 1000V and CAT II 600V.  
 EMC: Conforms to European Union Directive 89/336/EEC, EN61326-1.  
 Warranty: One year.



Model 2110 rear panel.

**2100**

# 6½-Digit USB Digital Multimeter



The Model 2100 USB Digital Multimeter is the newest member of Keithley's family of high performance DMMs. Its high accuracy (38ppm), 6½-digit resolution is ideal for critical measurements. The Model 2100 features 11 measurement functions and 8 math functions to easily accommodate the most commonly measured parameters. All accessories, such as USB cable, probes, and software, are included with the Model 2100. With its unique combination of high precision and low total cost of ownership, the Model 2100 is an unbeatable value for R&D engineers, test engineers, scientists, and students making basic precision measurements on the bench and in system applications.

## High Precision, Low Cost

The Model 2100 provides stability, accuracy, and speed at a very low cost. It has 0.0038% 1-year range. At 6½ digits, the Model 2100 delivers 50 triggered rdgs/s into its 2000 reading internal buffer. At the fast 4½ digit setting, it reads over 2000 rdgs/s into its 2000 reading internal buffer.

basic DC voltage accuracy on the 10V range and 0.013% 1-year basic resistance accuracy on the 10kΩ range. At 6½ digits, the Model 2100 delivers 50 triggered rdgs/s into its 2000 reading internal buffer. At the fast 4½ digit setting, it reads over 2000 rdgs/s into its 2000 reading internal buffer.

The Model 2100 provides a wide number of measurement ranges and functions:

- DC voltage: 0.1V, 1V, 10V, 100V, and 1000V
- AC voltage: 0.1V, 1V, 10V, 100V, and 750V
- DC current: 10mA, 100mA, 1A, and 3A
- AC current: 1A and 3A
- Two- and four-wire resistance: 100Ω, 1kΩ, 10kΩ, 100kΩ, 1MΩ, 10MΩ, and 100MΩ
- Frequency: From 3Hz to 300kHz
- Period measurement
- Diode measurement
- Programmable A-D converter and filter settings for signal to noise optimization

Additionally, eight mathematical operations can be performed on measurement readings: RATIO, %, Min/Max, NULL, Limits, mX+b, dB, and dBm testing. Microsoft Office, Word, and Excel add-in tools allow remote storage and recall of the measured values from these applications. A graphing utility enables charting of measurements versus time for trending and noise observations.

The TMC compliant USB remote interface enables control from a PC for consistent test/calibration procedure execution and easy re-use of existing SCPI programs, including Agilent Model 34401A command emulation.

## Simple to Use

The Model 2100 can be setup quickly and is very easy to use. It has a high contrast front panel and keypad that are intuitive and user-friendly. An easy to read 5×7 dot matrix, vacuum fluorescent display (VFD) offers three-color annunciators so users can easily distinguish each function symbol by its color.

## Strength and Versatility

With its rugged construction and rubber bumpers, the Model 2100 has the durability to withstand bench, portable, or stacking applications. A sturdy carrying handle facilitates transportability.

- **High precision 6½-digit DMM for critical measurements at a 5½-digit price**
- **11 measurement functions cover most commonly measured parameters**
- **Fully specified accuracies on all functions for ISO-compliant results**
- **Included PC software utilities for graphing and data sharing in both Microsoft® Word and Excel**
- **Rugged construction for durability in bench/portable applications**
- **Selectable front/rear inputs facilitate bench or rack use**
- **Includes all accessories, such as startup software, USB cable, power cable, and safety test lead, for lowest total cost**
- **CE compliant and UL listed**
- **TMC compliant USB 2.0 interface for use with SCPI test programs**

1.888.KEITHLEY (U.S. only)

[www.keithley.com](http://www.keithley.com)**KEITHLEY**

A Greater Measure of Confidence

A Tektronix Company

# 2100

## 6½-Digit USB Digital Multimeter

### Ordering Information

**2100/100** 6½-digit USB Digital Multimeter (100V)

**2100/120** 6½-digit USB Digital Multimeter (120V)

**2100/220** 6½-digit USB Digital Multimeter (220V)

**2100/230-240**  
6½-digit USB Digital Multimeter (230-240V)

### Accessories Supplied

Instruction manual on CD, Specifications, LabVIEW® Driver, Keithley I/O Layer, USB Cable, Power Cable, Safety Test Leads, KI-Tool, and KI-Link Add-in (Both Microsoft Word and Excel versions)

### Applications

The Model 2100 USB Digital Multimeter is ideal for applications in: electronic device, circuit, module, and product testing; low cost production testing of electrical and electronic components, sub-assemblies, and end products; and student lab assignments. Typical applications include:

- Test Engineers: Manual and semi-automatic electrical functional test
- Development Engineers: Electrical/electronic circuit and product validation
- Service/Calibration Technicians: Electronic product repair and calibration
- Research Scientists: Electrical and physics experiments testing
- Engineering Students: Electronic device and circuits experiment testing

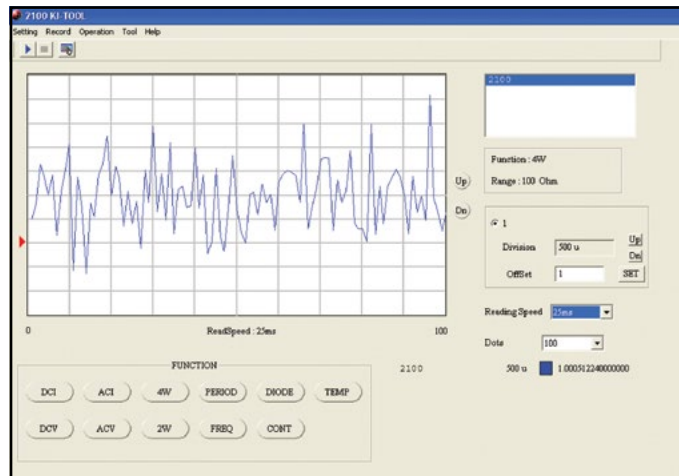

### ACCESSORIES AVAILABLE

#### RACK MOUNT KITS

4299-3	Single Rack Mount Kit
4299-4	Dual Rack Mount Kit
8605	High Performance Modular Test Leads
8606	High Performance Modular Probe Kit

#### SERVICES AVAILABLE

2100/120-3Y-EW	1 Year Factory Warranty extended to 3 years from date of shipment
C/2100/120-3Y-DATA	3 (Z540-1 compliant) Calibrations within 3 years of purchase for Model 2100/120*
C/2100/120-3Y-ISO	3 (ISO-17025 accredited) Calibrations within 3 years of purchase for Model 2100/120*

\*Not available in all countries

### Startup Software, PC Utilities Included

The KI-Tool application provides charting and graphing capabilities without programming to simplify setup, checkout, and basic measurement applications requiring graphical data representation. Scale, offset, and level can be adjusted to fine tune images for visual evaluation of signal and noise elements over time. It also includes tabular data and SCPI command prompt windows for maximum flexibility. Data sets can also be saved to disk files.

The Microsoft Excel Add-In utility is also included and provides quick data import into a standard Microsoft Excel spreadsheet, including selectable graphing, instrument settings, and number of data points collected. Data can then be analyzed through standard or optional Microsoft Excel functions, including graphical, statistical, and trend charting. A version supporting Microsoft Word is also included for direct data import into reports.

1.888.KEITHLEY (U.S. only)

www.keithley.com

A Greater Measure of Confidence

KEITHLEY

A Tektronix Company

Low cost 6½-digit DMM for portable, bench, and USB-based system applications

DIGITAL MULTIMETERS & SYSTEMS

## Specifications

### DC CHARACTERISTICS: Accuracy<sup>1</sup> ±(% of reading + % of range)

Function	Range	Resolution	Input Resistance	1 Year, 23°C ±5°C
DC Voltage	100.0000 mV	0.1 μV	>10 GΩ	0.0055 + 0.0040
	1.000000 V	1.0 μV	>10 GΩ	0.0045 + 0.0008
	10.00000 V	10 μV	>10 GΩ	0.0038 + 0.0006
	100.0000 V	100 μV	10 MΩ	0.0050 + 0.0007
	1000.000 V	1 mV	10 MΩ	0.0055 + 0.0010

Function	Range	Resolution	Shunt Resistance	1 Year, 23°C ±5°C
DCI (DC Current)	10.00000 mA	10 nA	5.1 Ω	0.055 + 0.025
	100.0000 mA	100 nA	5.1 Ω	0.055 + 0.006
	1.000000 A	1 μA	0.1 Ω	0.120 + 0.015
	3.00000 A	10 μA	0.1 Ω	0.150 + 0.025

Function	Range	Resolution	Test Current	1 Year, 23°C ±5°C
Resistance <sup>2</sup>	100.0000 Ω	100 μΩ	1 mA	0.015 + 0.005
	1.000000 kΩ	1 mΩ	1 mA	0.015 + 0.002
	10.00000 kΩ	10 mΩ	100 μA	0.013 + 0.002
	100.0000 kΩ	100 mΩ	10 μA	0.015 + 0.002
	1.000000 MΩ	1 Ω	5 μA	0.017 + 0.002
	10.00000 MΩ	10 Ω	500 nA	0.045 + 0.002
	100.0000 MΩ	100 Ω	500 nA    10 MΩ	1.00 + 0.020
Diode Test	1.0000 V	10 μV	1 mA	0.040 + 0.020
Continuity	1000.00 Ω	10 mΩ	1 mA	0.024 + 0.030

### DC NOTES

- Specifications valid after two hour warm-up.
  - ADC set for continuous trigger operation.
  - Input bias current <30pA at 25°C.
  - Input protection 1000V all ranges (2W input).
  - Measurement rate set to 1 PLC.
- Specifications for 4W ohms mode. For 2W ohms, use zero null or subtract lead resistance from displayed reading.
  - Maximum lead resistance 10% of range per lead for 100Ω and 1kΩ ranges; add 1kΩ per lead for all other ranges.

### MEASUREMENT NOISE REJECTION DC (60Hz/50Hz)

Rate	Digits	CMRR <sup>1</sup>	NMRR <sup>2</sup>
10PLC	6½	140 dB	60 dB
1PLC	5½	140 dB	60 dB

- For 1kΩ unbalance in LO lead.
- For line frequency ±0.1%.

### TEMPERATURE (RTD)

Range	Resolution	4-Wire Accuracy <sup>1</sup> , 1 Year
-100°C to +100°C	0.001°C	±0.1°C
-200°C to +630°C	0.001°C	±0.2°C

RTD TYPE: 100Ω platinum (PT100), D100, F100, PT385, or PT3916.

MAXIMUM LEAD RESISTANCE (each lead): 12Ω (to achieve rated accuracy).

SENSOR CURRENT: 1mA (pulsed).

- Excluding probe errors. 23°C ±5°C.

## AC CHARACTERISTICS:

Accuracy<sup>1</sup> ±(% of reading + % of range)

Function	Range	Frequency (Hz)	1 Year (% of reading) 23°C ±5°C
Frequency and Period	100 mV to 750 V <sup>2</sup>	3–5	0.10
		5–40	0.05
		40–300k	0.01

Function	Range	Resolution	Frequency (Hz)	1 Year (23°C ±5°C)
ACV (AC TRMS Voltage)	100.0000 mV	0.1 μV	3–5	1.15 + 0.05
			5–10	0.45 + 0.05
			10–20k	0.08 + 0.05
			20k–50k	0.15 + 0.06
			50k–100k	0.70 + 0.09
			100k–300k	4.25 + 0.60
	1.000000 V to 750.000 V <sup>2</sup>	1.0 μV to 1 mV	3–5	1.10 + 0.04
			5–10	0.4 + 0.04
			10–20k	0.08 + 0.04
			20k–50k	0.14 + 0.06
ACI (AC TRMS Current)	1.000000 A	1 μA	3–5	1.10 + 0.05
			5–10	0.40 + 0.05
			10–5k	0.15 + 0.05
			3–5	1.25 + 0.07
			5–10	0.45 + 0.07
3.000000 A	10 μA	5–10	0.45 + 0.07	
		10–5k	0.20 + 0.07	

## AC NOTES

- Specifications valid for two hour warm-up at 6½ digits.
  - Slow AC filter (3Hz bandwidth).
  - Pure sine wave input greater than 5% of range.
- 750VAC range is limited to 100kHz.

## GENERAL

AC CMRR: 70dB (for 1kΩ unbalance LO lead).  
 POWER SUPPLY: 120V/220V/240V.  
 POWER LINE FREQUENCY: 50/60Hz auto detected.  
 POWER CONSUMPTION: 25VA max.  
 DIGITAL I/O INTERFACE: USB-compatible Type B connection.  
 ENVIRONMENT: For indoor use only.  
 OPERATING TEMPERATURE: 5° to 40°C.  
 OPERATING HUMIDITY: Maximum relative humidity 80% for temperature up to 31°C, decreasing linearly to 50% relative humidity at 40°C.  
 STORAGE TEMPERATURE: –25° to 65°C.  
 OPERATING ALTITUDE: Up to 2000m above sea level.  
 BENCH DIMENSIONS (with handles and feet): 112mm high × 256mm wide × 375mm deep (4.4 in. × 10.1 in. × 14.75 in.).  
 WEIGHT: 4.1kg (9 lbs.).  
 SAFETY: Conforms to European Union Directive 73/23/ECC, EN61010-1, UL61010-1:2004.  
 EMC: Conforms to European Union Directive 89/336/EEC, EN61326-1.  
 WARRANTY: One year.



Model 2100 rear panel

1.888.KEITHLEY (U.S. only)

[www.keithley.com](http://www.keithley.com)

**KEITHLEY**

A Greater Measure of Confidence

A Tektronix Company

2000

## 6½-Digit Multimeter

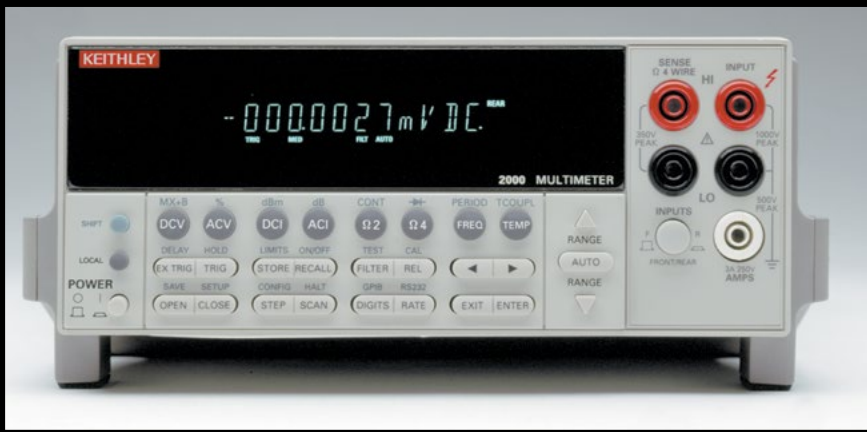

- 13 built-in measurement functions
- 2000 readings/second at 4½ digits
- Optional scanner cards for multipoint measurements
- GPIB and RS-232 interfaces
- Fluke 8840/42 command set

## Ordering Information

2000 6½-Digit DMM  
2000/2000-SCAN  
6½-Digit DMM/  
Scanner Combination

## Accessories Supplied

Instruction Manual and Model  
1751 Safety Test Leads

## ACCESSORIES AVAILABLE

2000-SCAN	10-channel, General-Purpose Scanner Card
2001-SCAN	10-channel Scanner Card with two high-speed channels
2001-TCSCAN	9-channel, Thermocouple Scanner Card with built-in cold junction

## CABLES/ADAPTERS

7007-1	Shielded IEEE-488 Cable, 1m (3.3 ft)
7007-2	Shielded IEEE-488 Cable, 2m (6.6 ft)
7009-5	RS-232 Cable

## RACK MOUNT KITS

4288-1	Single Fixed Rack Mount Kit
4288-2	Dual Fixed Rack Mount Kit

## GPIB INTERFACES

KPCI-488LPA	IEEE-488 Interface/Controller for the PCI Bus
KUSB-488B	IEEE-488 USB-to-GPIB Interface Adapter

## SERVICES AVAILABLE

2000-SCAN-3Y-EW	1-year factory warranty extended to 3 years from date of shipment
2000-3Y-EW	1-year factory warranty extended to 3 years from date of shipment
2001-TCSCAN-3Y-EW	1-year factory warranty extended to 3 years from date of shipment
C/2000-3Y-ISO	3 (ISO-17025 accredited) calibrations within 3 years of purchase for Models 2000, 2000-SCAN*
C/2001-3Y-ISO	3 (ISO-17025 accredited) calibrations within 3 years of purchase for Model 2001-TCSCAN*

\*Not available in all countries

The Model 2000 6½-Digit Multimeter is part of Keithley's family of high performance DMMs. Based on the same high speed, low noise A/D converter technology as the Model 2001 and 2002, the 2000 is a fast, accurate, and highly stable instrument that's as easy to operate as it is to afford. It combines broad measurement ranges with superior accuracy specifications — DC voltage from 100nV to 1kV (with 0.002% 90-day basic accuracy) and DC resistance from 100μΩ to 100MΩ (with 0.008% 90-day basic accuracy). Optional switch cards enable multiplexing up to 20 different input signals for multipoint measurement applications.

## High Throughput

The 2000 offers exceptional measurement speed at any resolution. At 6½ digits, it delivers 50 triggered rdgs/s over the IEEE-488 bus. At 4½ digits, it can read up to 2000 rdgs/s into its internal 1024 reading buffer, making it an excellent choice for applications where throughput is critical.

For benchtop or stand-alone applications, the 2000 has a front panel design that's simple to understand and easy to use. The 2000 has 13 built-in measurement functions, including DCV, ACV, DCI, ACI, 2WΩ, 4WΩ, temperature, frequency, period, dB, dBm, continuity measurement, and diode testing. A built-in RS-232 interface connects to a notebook or full-sized PC's serial port to take, store, process, and display measurements automatically.

1.888.KEITHLEY (U.S. only)

www.keithley.com

KEITHLEY

A Greater Measure of Confidence

A Tektronix Company

# 2000

# 6½-Digit Multimeter

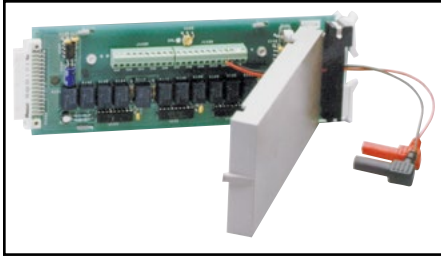

## Optional Multiplexer Cards

Creating a self-contained multipoint measurement solution is as simple as plugging a scanner card into the option slot on the 2000's back panel. This approach eliminates the complexities of triggering, timing, and processing issues and helps reduce test time significantly. For applications involving more than 10 measurement points, the 2000 is compatible with Keithley's Series 7000 switch matrices and cards.

### Model 2000-SCAN Scanner Card

- Ten analog input channels (2-pole)
- Configurable as 4-pole, 5-channel

### Model 2001-SCAN Scanner Card

- Ten analog input channels
- Two channels of 2-pole, high-speed, solid-state switching

### Model 2001-TCSCAN Thermocouple Scanner Card

- Nine analog input channels
- Built-in temperature reference for thermocouple cold-junction compensation

## SCANNER OPTION 2000-SCAN

**GENERAL:** 10 channels of 2-pole relay input. All channels configurable to 4-pole.

**CAPABILITIES:** Multiplex one of ten 2-pole or one of five 4-pole signals into DMM.

### INPUTS

#### Maximum Signal Level:

**DC Signals:** 110V DC, 1A switched, 30VA maximum (resistive load).

**AC Signals:** 125V AC rms or 175V AC peak, 100kHz maximum, 1A switched, 62.5VA maximum (resistive load).

**Contact Life:** >10<sup>8</sup> operations at maximum signal level; >10<sup>8</sup> operations cold switching.

**Contact Resistance:** <1Ω at end of contact life.

**Actuation Time:** 2.5ms maximum on/off.

**Contact Potential:** <±500nV typical per contact, 1μV max. <±500nV typical per contact pair, 1μV max.

**Connector Type:** Screw terminal, #22 AWG wire size.

**Isolation Between Any Two Terminals:** >10<sup>9</sup>Ω, <75pF.

**Isolation Between Any Terminal and Earth:** >10<sup>9</sup>Ω, <150pF.

**Common Mode Voltage:** 350V peak between any terminal and earth.

**Maximum Voltage Between Any Two Terminals:** 200V peak.

**Maximum Voltage Between Any Terminal and Model 2001 Input LO:** 200V peak.

**ENVIRONMENTAL:** Meets all Model 2000 environmental specifications.

**DIMENSIONS, WEIGHT:** 21mm high × 72mm wide × 221mm deep (0.83 in. × 2.83 in. × 8.7 in.). Adds 0.4kg (10 oz.).

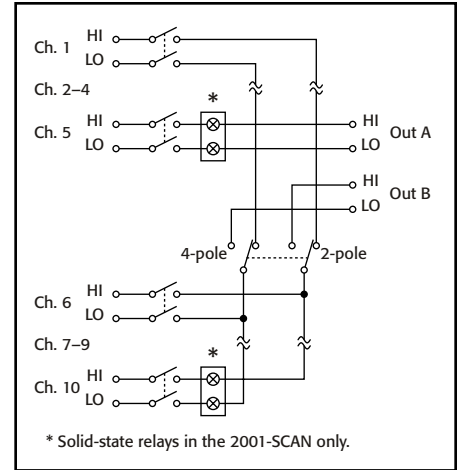

**Scanner Configuration for Models 2000-SCAN and 2001-SCAN**

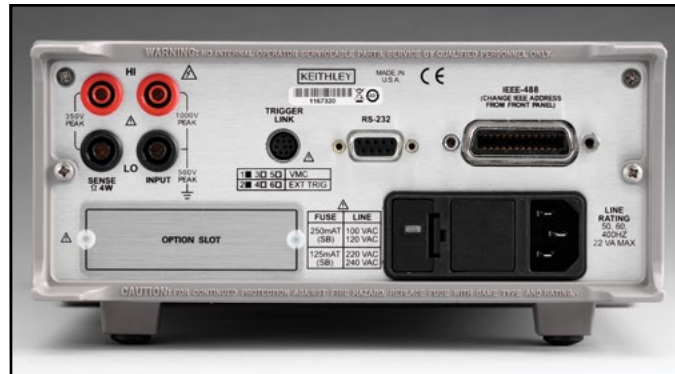

1.888.KEITHLEY (U.S. only)

[www.keithley.com](http://www.keithley.com)

A Greater Measure of Confidence

**KEITHLEY**

A Tektronix Company

General-purpose instrument that's as easy to operate as it is to afford

DIGITAL MULTIMETERS & SYSTEMS



## DC Characteristics

Conditions: MED (1 PLC)<sup>1</sup> or SLOW (10 PLC) or MED (1 PLC) with filter of 10

Accuracy: ±(ppm of reading + ppm of range)  
(ppm = parts per million)  
(e.g., 10ppm = 0.001%)

Function	Range	Resolution	Test Current or Burden Voltage (±5%)	Input Resistance	Accuracy			Temperature Coefficient 0°–18°C and 28°–50°C
					24 Hour <sup>14</sup> 23°C ± 1°	90 Day 23°C ± 5°	1 Year 23°C ± 5°	
Voltage	100.0000 mV	0.1 μV		> 10 GΩ	30 + 30	40 + 35	50 + 35	2 + 6
	1.000000 V	1.0 μV		> 10 GΩ	15 + 6	25 + 7	30 + 7	2 + 1
	10.00000 V	10 μV		> 10 GΩ	15 + 4	20 + 5	30 + 5	2 + 1
	100.0000 V	100 μV		10 MΩ ±1%	15 + 6	30 + 6	45 + 6	5 + 1
	1000.000 V <sup>9</sup>	1 mV		10 MΩ ±1%	20 + 6	35 + 6	45 + 6	5 + 1
Resistance <sup>15</sup>	100.0000 Ω	100 μΩ	1 mA		30 + 30	80 + 40	100 + 40	8 + 6
	1.000000 kΩ	1 mΩ	1 mA		20 + 6	80 + 10	100 + 10	8 + 1
	10.00000 kΩ	10 mΩ	100 μA		20 + 6	80 + 10	100 + 10	8 + 1
	100.0000 kΩ	100 mΩ	10 μA		20 + 6	80 + 10	100 + 10	8 + 1
	1.000000 MΩ <sup>16</sup>	1 Ω	10 μA		20 + 6	80 + 10	100 + 10	8 + 1
	10.00000 MΩ <sup>11, 16</sup>	10 Ω	700 nA // 10MΩ		150 + 6	200 + 10	400 + 10	95 + 1
	100.0000 MΩ <sup>11, 16</sup>	100 Ω	700 nA // 10MΩ		800 + 30	1500 + 30	1500 + 30	900 + 1
Current	10.00000 mA	10 nA	< 0.15 V		60 + 30	300 + 80	500 + 80	50 + 5
	100.0000 mA	100 nA	< 0.03 V		100 + 300	300 + 800	500 + 800	50 + 50
	1.000000 A	1 μA	< 0.3 V		200 + 30	500 + 80	800 + 80	50 + 5
	3.00000 A	10 μA	< 1 V		1000 + 15	1200 + 40	1200 + 40	50 + 5
Continuity 2W	1 kΩ	100 mΩ	1 mA		40 + 100	100 + 100	120 + 100	8 + 1
Diode Test	3.00000 V	10 μV	1 mA		20 + 6	30 + 7	40 + 7	8 + 1
	10.00000 V	10 μV	100 μA		20 + 6	30 + 7	40 + 7	8 + 1
	10.00000 V	10 μV	10 μA		20 + 6	30 + 7	40 + 7	8 + 1

## DC OPERATING CHARACTERISTICS<sup>2</sup>

Function	Digits	Readings/s	PLCs <sup>8</sup>
DCV (all ranges),	6 <sup>1</sup> / <sub>2</sub> <sup>3, 4</sup>	5	10
DCI (all ranges), and	6 <sup>1</sup> / <sub>2</sub> <sup>3, 7</sup>	30	1
Ohms (<10M range)	6 <sup>1</sup> / <sub>2</sub> <sup>3, 5</sup>	50	1
	5 <sup>1</sup> / <sub>2</sub> <sup>3, 5</sup>	270	0.1
	5 <sup>1</sup> / <sub>2</sub> <sup>5</sup>	500	0.1
	5 <sup>1</sup> / <sub>2</sub> <sup>5</sup>	1000	0.04
	4 <sup>1</sup> / <sub>2</sub> <sup>5</sup>	2000	0.01

## DC SYSTEM SPEEDS<sup>2, 6</sup>

RANGE CHANGE<sup>3</sup>: 50/s.

FUNCTION CHANGE<sup>3</sup>: 45/s.

AUTORANGE TIME<sup>3, 10</sup>: <30ms.

ASCII READINGS TO RS-232 (19.2K BAUD): 55/s.

MAX. INTERNAL TRIGGER RATE: 2000/s.

MAX. EXTERNAL TRIGGER RATE: 400/s.

## DC GENERAL

LINEARITY OF 10VDC RANGE: ±(1ppm of reading + 2ppm of range).

DCV, Ω, TEMPERATURE, CONTINUITY, DIODE TEST INPUT PROTECTION: 1000V, all ranges.

MAXIMUM 4WΩ LEAD RESISTANCE: 10% of range per lead for 100Ω and 1kΩ ranges; 1kΩ per lead for all other ranges.

DC CURRENT INPUT PROTECTION: 3A, 250V fuse.

SHUNT RESISTOR: 0.1Ω for 3A, 1A, and 100mA ranges. 10Ω for 10mA range.

CONTINUITY THRESHOLD: Adjustable 1Ω to 1000Ω.

AUTOZERO OFF ERROR: Add ±(2ppm of range error + 5μV) for <10 minutes and ±1°C change.

OVERRANGE: 120% of range except on 1000V, 3A, and diode.

## SPEED AND NOISE REJECTION

Rate	Readings/s	Digits	RMS Noise 10V		
			Range	NMRR <sup>12</sup>	CMRR <sup>13</sup>
10 PLC	5	6 <sup>1</sup> / <sub>2</sub>	< 1.5 μV	60 dB	140 dB
1 PLC	50	6 <sup>1</sup> / <sub>2</sub>	< 4 μV	60 dB	140 dB
0.1 PLC	500	5 <sup>1</sup> / <sub>2</sub>	< 22 μV	—	80 dB
0.01 PLC	2000	4 <sup>1</sup> / <sub>2</sub>	< 150 μV	—	80 dB

## DC NOTES

- Add the following to "ppm of range" uncertainty: 1V and 100V, 2ppm; 100mV, 15ppm; 100Ω, 15ppm; 1kΩ–<1MΩ, 2ppm; 10mA and 1A, 10ppm; 100mA, 40ppm.
- Speeds are for 60Hz operation using factory default operating conditions (\*RST). Autorange off, Display off, Trigger delay = 0.
- Speeds include measurement and binary data transfer out the GPIB.
- Auto zero off.
- Sample count = 1024, auto zero off.
- Auto zero off, NPLC = 0.01.
- Ohms = 24 readings/second.
- 1 PLC = 16.67ms @ 60Hz, 20ms @ 50Hz/400Hz. The frequency is automatically determined at power up.
- For signal levels >500V, add 0.02ppm/V uncertainty for the portion exceeding 500V.
- Add 120ms for ohms.
- Must have 10% matching of lead resistance in Input HI and LO.
- For line frequency ±0.1%.
- For 1kΩ unbalance in LO lead.
- Relative to calibration accuracy.
- Specifications are for 4-wire ohms. For 2-wire ohms, add 1Ω additional uncertainty.
- For rear inputs, add the following to temperature coefficient "ppm of reading" uncertainty 10MΩ 95ppm, 100MΩ 900ppm. Operating environment specified for 0° to 50°C and 50% RH at 35°C.

1.888.KEITHLEY (U.S. only)

www.keithley.com

KEITHLEY

A Greater Measure of Confidence

A Tektronix Company

# 2000

# 6½-Digit Multimeter

## True RMS AC Voltage and Current Characteristics

		Accuracy <sup>1</sup> : ±(% of reading + % of range), 23°C ±5 °C					
Voltage Range	Resolution	Calibration Cycle	3 Hz–10 Hz <sup>10</sup>	10 Hz–20 kHz	20 kHz–50 kHz	50 kHz–100 kHz	100 kHz–300 kHz
100.0000 mV	0.1 µV						
1.000000 V	1.0 µV	90 Days	0.35 + 0.03	0.05 + 0.03	0.11 + 0.05	0.60 + 0.08	4 + 0.5
10.00000 V	10 µV						
100.0000 V	100 µV	1 Year	0.35 + 0.03	0.06 + 0.03	0.12 + 0.05	0.60 + 0.08	4 + 0.5
750.000 V	1 mV						
<b>Temperature Coefficient/°C<sup>8</sup></b>			0.035 + 0.003	0.005 + 0.003	0.006 + 0.005	0.01 + 0.006	0.03 + 0.01

Current Range	Resolution	Calibration Cycle	3 Hz–10 Hz	10 Hz–3 kHz	3 kHz–5 kHz
1.000000 A	1 µA	90 Day/1 Year	0.30 + 0.04	0.10 + 0.04	0.14 + 0.04
3.00000 A <sup>9</sup>	10 µA	90 Day/1 Year	0.35 + 0.06	0.15 + 0.06	0.18 + 0.06
<b>Temperature Coefficient/°C<sup>8</sup></b>			0.035 + 0.006	0.015 + 0.006	0.015 + 0.006

### HIGH CREST FACTOR ADDITIONAL ERROR ±(% of reading)<sup>7</sup>

CREST FACTOR:	1–2	2–3	3–4	4–5
ADDITIONAL ERROR:	0.05	0.15	0.30	0.40

### AC OPERATING CHARACTERISTICS<sup>2</sup>

Function	Digits	Readings/s	Rate	Bandwidth
ACV (all ranges), and	6½ <sup>3</sup>	2s/reading	SLOW	3 Hz–300 kHz
ACI (all ranges)	6½ <sup>3</sup>	1.4	MED	30 Hz–300 kHz
	6½ <sup>4</sup>	4.8	MED	30 Hz–300 kHz
	6½ <sup>3</sup>	2.2	FAST	300 Hz–300 kHz
	6½ <sup>4</sup>	35	FAST	300 Hz–300 kHz

### ADDITIONAL LOW FREQUENCY ERRORS ±(% of reading)

	Slow	Med	Fast
20 Hz – 30 Hz	0	0.3	—
30 Hz – 50 Hz	0	0	—
50 Hz – 100 Hz	0	0	1.0
100 Hz – 200 Hz	0	0	0.18
200 Hz – 300 Hz	0	0	0.10
> 300 Hz	0	0	0

### AC SYSTEM SPEEDS<sup>2, 5</sup>

FUNCTION/RANGE CHANGE<sup>4</sup>: 4/s.  
 AUTORANGE TIME: <3s.  
 ASCII READINGS TO RS-232 (19.2K BAUD)<sup>4</sup>: 50/s.  
 MAX. INTERNAL TRIGGER RATE<sup>4</sup>: 300/s.  
 MAX. EXTERNAL TRIGGER RATE<sup>4</sup>: 300/s.

### AC GENERAL

INPUT IMPEDANCE: 1MΩ ±2% paralleled by <100pF.  
 ACV INPUT PROTECTION: 1000Vp.  
 MAXIMUM DCV: 400V on any ACV range.  
 ACI INPUT PROTECTION: 3A, 250V fuse.  
 BURDEN VOLTAGE: 1A Range: <0.3V rms. 3A Range: <1V rms.  
 SHUNT RESISTOR: 0.1Ω on all ACI ranges.  
 AC CMRR: >70dB with 1kΩ in LO lead.  
 MAXIMUM CREST FACTOR: 5 at full scale.  
 VOLT HERTZ PRODUCT: ≤8 × 10<sup>7</sup> V·Hz.  
 OVERRANGE: 120% of range except on 750V and 3A ranges.

### AC NOTES

- Specifications are for SLOW rate and sine wave inputs >5% of range.
- Speeds are for 60Hz operation using factory default operating conditions (\*RST). Auto zero off, Auto range off, Display off, includes measurement and binary data transfer out the GPIB.
- 0.01% of step settling error. Trigger delay = 400ms.
- Trigger delay = 0.
- DETECTOR: BANDwidth 300, NPLC = 0.01.
- Maximum useful limit with trigger delay = 175ms.
- Applies to non-sinewaves >5Hz and <500Hz (guaranteed by design for crest factors >4.3).
- Applies to 0°–18°C and 28°–50°C.
- For signal levels >2.2A, add additional 0.4% to "of reading" uncertainty.
- Typical uncertainties. Typical represents two sigma or 95% of manufactured units measure <0.35% of reading and three sigma or 99.7% measure <1.06% of reading.

1.888.KEITHLEY (U.S. only)

www.keithley.com

A Greater Measure of Confidence

KEITHLEY

A Tektronix Company

Model 2000 specifications

DIGITAL MULTIMETERS & SYSTEMS

## Triggering and Memory

READING HOLD SENSITIVITY: 0.01%, 0.1%, 1%, or 10% of reading.

TRIGGER DELAY: 0 to 99 hrs (1ms step size).

EXTERNAL TRIGGER LATENCY: 200 $\mu$ s + <300 $\mu$ s jitter with autozero off, trigger delay = 0.

MEMORY: 1024 readings.

## Math Functions

Rel, Min/Max/Average/StdDev (of stored reading), dB, dBm, Limit Test, %, and mX+b with user defined units displayed.

DBM REFERENCE RESISTANCES: 1 to 9999 $\Omega$  in 1 $\Omega$  increments.

## Standard Programming Languages

SCPI (Standard Commands for Programmable Instruments)

Keithley 196/199

Fluke 8840A, Fluke 8842A

## Remote Interface

GPIO (IEEE-488.1, IEEE-488.2) and RS-232C.

## Frequency and Period Characteristics <sup>1, 2</sup>

ACV Range	Frequency Range	Period Range	Gate Time	Resolution $\pm$ (ppm of reading)	Accuracy 90 Day/1 Year $\pm$ (% of reading)
100 mV to 750 V	3 Hz to 500 kHz	333 ms to 2 $\mu$ s	1 s (SLOW)	0.3	0.01

### FREQUENCY NOTES

- Specifications are for square wave inputs only. Input signal must be >10% of ACV range. If input is <20mV on the 100mV range, then frequency must be >10Hz.
- 20% overrange on all ranges except 750V range.

## Temperature Characteristics

### Thermocouple <sup>2, 3, 4</sup>

Type	Range	Resolution	Accuracy <sup>1</sup> 90 Day/1 Year (23°C $\pm$ 5°C)	
			Relative to Reference Junction	Using 2001-TCSCAN <sup>5</sup>
J	-200 to + 760°C	0.001°C	$\pm$ 0.5°C	$\pm$ 0.65°C
K	-200 to +1372°C	0.001°C	$\pm$ 0.5°C	$\pm$ 0.70°C
T	-200 to + 400°C	0.001°C	$\pm$ 0.5°C	$\pm$ 0.68°C

### TEMPERATURE NOTES

- For temperatures <-100°C, add  $\pm$ 0.1°C and >900°C add  $\pm$ 0.3°C.
- Temperature can be displayed in °C, K or °F.
- Accuracy based on ITS-90.
- Exclusive of thermocouple error.
- Specifications apply to channels 2-6. Add 0.06°C/channel from channel 6.

## GENERAL

POWER SUPPLY: 100V / 120V / 220V / 240V.

LINE FREQUENCY: 50Hz to 60Hz and 400Hz, automatically sensed at power-up.

POWER CONSUMPTION: 22VA.

VOLT HERTZ PRODUCT:  $\leq 8 \times 10^7$  V·Hz.

OPERATING ENVIRONMENT: Specified for 0°C to 50°C. Specified to 80% R.H. at 35°C and at an altitude of up to 2000m.

STORAGE ENVIRONMENT: -40°C to 70°C.

SAFETY: Conforms to European Union Low Voltage Directive.

EMC: Conforms to European Union EMC Directive.

WARMUP: 1 hour to rated accuracy.

VIBRATION: MIL-PRF-2800F Class 3 Random.

### DIMENSIONS:

Rack Mounting: 89mm high  $\times$  213mm wide  $\times$  370mm deep (3.5 in  $\times$  8.38 in  $\times$  14.56 in).

Bench Configuration (with handle and feet): 104mm high  $\times$  238mm wide  $\times$  370mm deep (4.13 in  $\times$  9.38 in  $\times$  14.56 in).

NET WEIGHT: 2.9kg (6.3 lbs).

SHIPPING WEIGHT: 5kg (11 lbs).

1.888.KEITHLEY (U.S. only)

[www.keithley.com](http://www.keithley.com)

2001  
2002

# 7½-Digit High Performance Multimeter 8½-Digit High Performance Multimeter



- True 7½- (Model 2001) or 8½-digit (Model 2002) resolution
- Exceptional measurement integrity with high speed
- High speed function and range changing
- Broad range of built-in measurement functions
- Multiple measurement display
- Built-in 10 channel scanner option
- GPIB interface
- HP3458A emulation mode (Model 2002)

DMM users whose applications demand exceptional resolution, accuracy, and sensitivity combined with high throughput now have two attractive alternatives to high priced, high end DMMs. Keithley's 7½-digit Model 2001 and 8½-digit Model 2002 High Performance Digital Multimeters not only deliver performance specifications usually associated with instruments that cost thousands more, but they also offer a broad range of functions not typically available from DMMs. The 2002 is based on the same superior measurement technology as the 2001, and the front panels of both instruments have the same look, feel, and response.

## True 7½- (or 8½-) Digit Resolution

While other DMMs may claim 7½- or 8½-digit resolution, they must average multiple readings to extend their resolution. The resolution specifications of the 2001 and 2002 are based on a 28-bit A/D converter that provides the resolution needed to discern smaller changes. This higher resolution also provides greater dynamic range, making it possible to measure from 1µV to 20V on a single range, thus avoiding range-shift errors and delays.

## Built-In Scanner (Multiplexer) Options

With the addition of a plug-in scanner card, the 2001 or 2002 becomes a complete scan and measure system for applications involving up to ten measurement points. The additional resolution and measurement ranges provided by the 2002 make it an excellent choice for production test, design verification, and metrology applications where high accuracy is critical.



and metrology applications where high accuracy is critical.

## High Accuracy ACV Measurements

A patented circuit design makes the 2001 and 2002's AC measurements several times more accurate than competitive DMMs. In this circuit, the signal bypasses the prime error-contributing section of conventional rms converters. This increases the accuracy at almost any voltage level, and also increases sensitivity down to a guaranteed 1% of the selected range, compared to 5–10% for most other DMMs. The result is highly accurate measurements over a broad range of inputs.

Applications involving vibration, servo, guidance, shock, and control systems often require accurate low frequency ACV measurements. The 2001 and 2002 maintain very good accuracy (better than 0.1%) down to 1Hz. The wide bandwidth of these DMMs allows for accurate measurements of high frequency AC signals without the need for a special AC meter. Both the 2001 and 2002 feature TRMS AC, average AC, peak AC, AC+DC, and crest factor measurement capability for a wide variety of applications.

## High Speed for High Throughput

In applications where high throughput is critical, both the 2001 and 2002 provide more than 2000 readings per second at 4½-digit resolution. At 7½ digits, the 2002 maintains full rated accuracy at reading rates up to 44/second on DCV and ohms.

## High Speed, High Precision Resistance Measurements

The Model 2002 uses a unique single-phase method for 4-wire ohms measurements. This makes it twice as fast for a given power line cycle rate. This also eliminates errors due to changing lead resistances that can result from fast test handlers. A built-in open-lead detection circuit also eliminates many production test problems.

## Fast, Flexible Triggering

Trigger latency—the delay between trigger and measurement—is often a barrier to higher throughput. Also, variability in latency can complicate predicting measurement timing. The 2001 and 2002 trigger is less than 2µs±1µs, which is much faster than typical system DMMs.

1.888.KEITHLEY (U.S. only)

www.keithley.com

A Greater Measure of Confidence

KEITHLEY

A Tektronix Company

High resolution, high accuracy DMMs

DIGITAL MULTIMETERS & SYSTEMS

**2001  
2002**

# 7½-Digit High Performance Multimeter 8½-Digit High Performance Multimeter

## Ordering Information

**2001 High Performance 7½-Digit DMM with 8K Memory**

**2002 High Performance 8½-Digit DMM with 8K Memory**

**2000-SCAN  
10-channel Scanner Card**

**2001-SCAN  
10-channel Scanner Card with two high-speed channels**

**2001-TCSCAN  
9-channel Thermocouple Scanner Card**

**2001/MEM1  
High Performance 7½-Digit DMM with 32K Memory**

**2001/MEM2  
High Performance 7½-Digit DMM with 128K Memory**

**2002/MEM1  
High Performance 8½-Digit DMM with 32K Memory**

**2002/MEM2  
High Performance 8½-Digit DMM with 128K Memory**

## Accessories Supplied

**Model 8605 High Performance Modular Test Leads, user's manual, option slot cover, and full calibration data.**

**For more information, request the Model 2001 and 2002 Technical Specifications books.**

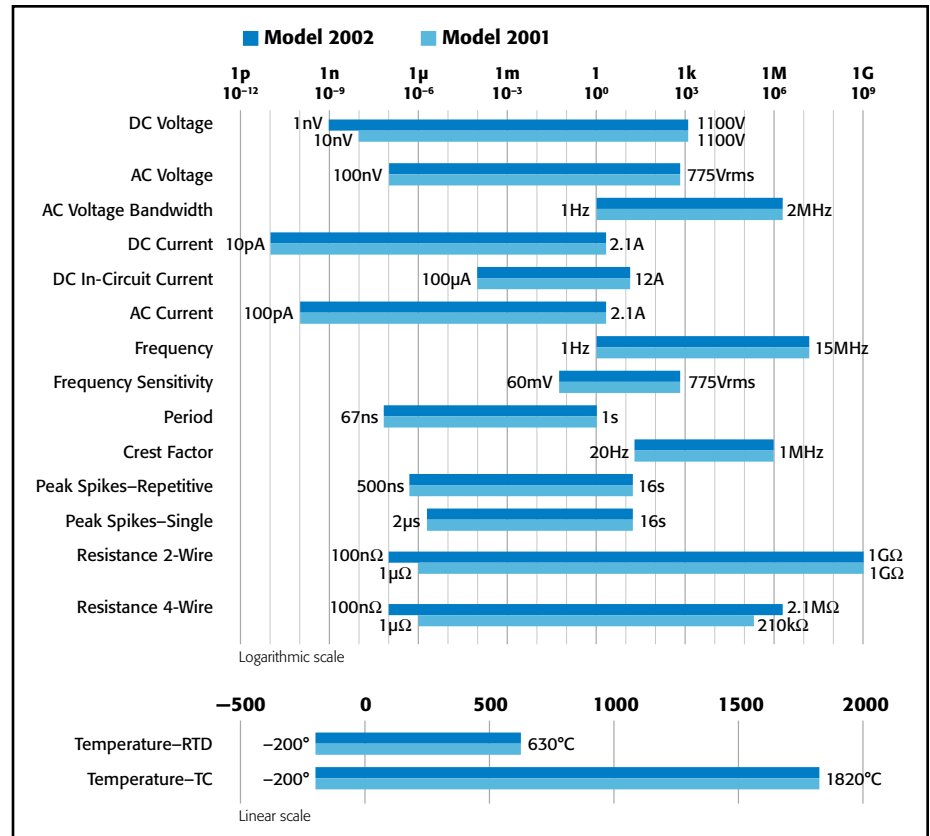

**Both the 2001 and 2002 provide exceptional measurement range. In addition, the 2002 offers extended DCV and resistance measurement capabilities.**

The unique Trigger-Link feature included in the Model 2001 and 2002 and most Keithley test and measurement products can be used to coordinate the operation of two or more instruments. Trigger-Link combines six independent software selectable trigger lines on a single connector for simple, direct control over all instruments in a system.

### Spot Trends with the Bar-Graph Display

The ability to track reading trends around a target value easily can be just as important as the absolute readings. A unique bar-graph display function in the 2001 and 2002 indicates data as a percentage of the selected range from ±0.01% to ±100%. Whether adjusting about zero or any other desired value, this display can replace a nulling differential voltmeter.

### Capture Spikes Down to 1µs

Both the 2001 and 2002 have internal peak detectors that can catch 1µs spikes such as power supply spikes and transients, AC line power surges, and short-duration dropouts on components. These peak detectors operate up to 1MHz for repetitive signals or down to 1µs for single spikes, so there is no need for a separate scope. The DMMs can automatically display and store the highest value or display the maximum and minimum values of spikes.

### Built-in Features and Capabilities

The 2001 and 2002 offer many built-in measurements that are typically unavailable in instruments of this type, including in-circuit current, temperature with thermocouples or RTDs, and peak spikes. Four separate outputs linked to limits simplify configuring the DMMs for use in binning operations.

High resolution, high accuracy DMMs

DIGITAL MULTIMETERS & SYSTEMS

1.888.KEITHLEY (U.S. only)

[www.keithley.com](http://www.keithley.com)

**KEITHLEY**

A Tektronix Company

A Greater Measure of Confidence

# 2001 2002

# 7½-Digit High Performance Multimeter 8½-Digit High Performance Multimeter

The built-in AC crest factor measurement helps ensure the accuracy of AC measurements. Other DMMs typically perform AC measurements for signals without excessive crest factor—the ratio of peak value to rms values. However, when crest factor rises, measurements may not meet specs. With a 2001 or 2002, there is no need for an oscilloscope to determine if the crest factor is acceptable—the DMM measures it directly.

While some DMMs calculate average AC from the rms value, these calculations apply only to sine wave inputs. The 2001 and 2002 measure peak value, average and true rms directly to obtain a complete characterization of the signal. This capability makes these DMMs ideal for AC circuit design or test applications and for verifying test voltages specified only in averages.

When measuring AC or digital signals, frequency is critical. The 2001 and 2002 accurately measure frequency up to 15MHz. Accurate triggering on the signal is critical to measure frequency reliably. The frequency counters in the 2001

and 2002 have a fully adjustable trigger level for good measurements of noisy signals.

## Multiple Measurement Display

The 2001 and 2002 can display DC and AC volts and the AC frequency from a single measurement connection simultaneously. Several other multiple-measurement displays are available, including crest factor and bar graph. By measuring sequentially and displaying simultaneously, the 2001/2002 operates as if three different meters are working together.

## Option Slot Extends DMM Performance

An option slot in the back of the 2001 and 2002 opens the door to a wide range of measurement capabilities. Choose a 10-channel general-purpose scanner card or a 9-channel thermocouple scanner card to make measurements on multiple test points or devices. This can eliminate the need for a separate scanner and significantly reduce programming and setup time.

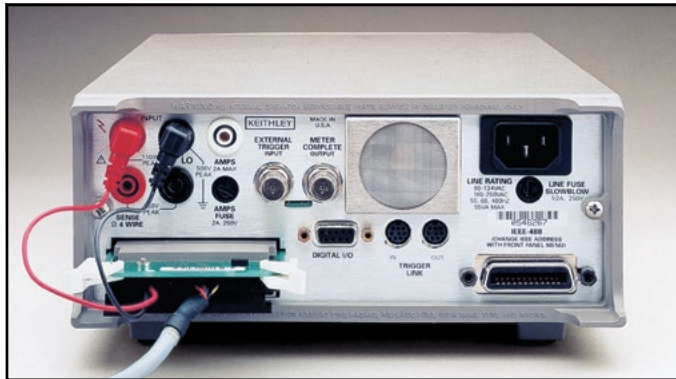

## ACCESSORIES AVAILABLE

### TEST LEADS AND PROBES

5805	Kelvin Probes, 0.9m (3ft)
5805-12	Kelvin Probes, 3.6m (12ft)
5808	Low Cost, Single Pin, Kelvin Probes
5809	Low Cost, Kelvin Clip Lead Set
8502	Micro-DIN to 6 BNCs Adapter Box with 8501-1 Cable
8530	Centronics Adapter
8605	High Performance 2-Wire Modular Test Leads
8606	High Performance Modular Probe Kit
8610	Low Thermal Shorting Plug
8680	RTD Probe Adapter
8681	Low Cost RTD

### CABLES/ADAPTERS

7007-1	Shielded GPIB Cable, 1m (3.3 ft)
7007-2	Shielded GPIB Cable, 2m (6.6 ft)
8501-1	Trigger-Link Cable, 1m (3.3 ft)
8501-2	Trigger Link Cable, 2m (6.6 ft)
8502	Trigger Link Adapter Box
8610	Low Thermal Shorting Plug
8620	4-Wire DMM Shorting Plug

### RACK MOUNT KITS

4288-1	Single Fixed Rack Mount Kit
4288-4	Side-by-Side Rack Mount Kit

### GPIB INTERFACES

KPCI-488LPA	IEEE-488 Interface Controller for the PCI Bus
KUSB-488B	IEEE-488 USB-to-GPIB Interface Adapter

## SERVICES AVAILABLE

2000-SCAN-3Y-EW	1-year factory warranty extended to 3 years from date of shipment
2001/MEM1-3Y-EW	1-year factory warranty extended to 3 years from date of shipment
2001/MEM2-3Y-EW	1-year factory warranty extended to 3 years from date of shipment
2001-SCAN-3Y-EW	1-year factory warranty extended to 3 years from date of shipment
2001-TCSCAN-3Y-EW	1-year factory warranty extended to 3 years from date of shipment
2001-3Y-EW	1-year factory warranty extended to 3 years from date of shipment
2002/MEM1-3Y-EW	1-year factory warranty extended to 3 years from date of shipment
2002/MEM2-3Y-EW	1-year factory warranty extended to 3 years from date of shipment
2002-3Y-EW	1-year factory warranty extended to 3 years from date of shipment
C/2000-3Y-ISO	3 (ISO-17025 accredited) calibrations within 3 years of purchase for Model 2000-SCAN*
C/2001-3Y-ISO	3 (ISO-17025 accredited) calibrations within 3 years of purchase for Models 2001, 2001/MEM1, 2001/MEM2, 2001-SCAN, 2001-TCSCAN*
C/2002-3Y-ISO	3 (ISO-17025 accredited) calibrations within 3 years of purchase for Models 2002, 2002/MEM1, 2002/MEM2*

\*Not available in all countries

1.888.KEITHLEY (U.S. only)

www.keithley.com

A Greater Measure of Confidence

KEITHLEY

A Tektronix Company

High resolution, high accuracy DMMs

DIGITAL MULTIMETERS & SYSTEMS

# 2001 2002

# 7½-Digit High Performance Multimeter 8½-Digit High Performance Multimeter

## 2001 Condensed Specifications

### DC VOLTS

#### DCV INPUT CHARACTERISTICS AND ACCURACY

Range	Full Scale	Resolution	Default Resolution	Input Resistance	Accuracy ±(ppm of reading + ppm of range)				
					5	24	90	1	2
					Minutes <sup>4</sup>	Hours <sup>1</sup>	Days <sup>2</sup>	Year <sup>2</sup>	Years <sup>2</sup>
200 mV <sup>3</sup>	±210.00000 mV	10 nV	100 nV	>10 GΩ	3 + 3	10 + 6	25 + 6	37 + 6	50 + 6
2 V	±2.1000000 V	100 nV	1 μV	>10 GΩ	2 + 1.5	7 + 2	18 + 2	25 + 2	32 + 2
20 V	±21.000000 V	1 μV	10 μV	>10 GΩ	2 + 1.5	7 + 4	18 + 4	24 + 4	32 + 4
200 V	±210.00000 V	10 μV	100 μV	10 MΩ ±1%	2 + 1.5	13 + 3	27 + 3	38 + 3	52 + 3
1000 V	±1100.0000 V	100 μV	1 mV	10 MΩ ±1%	10 + 1.5	17 + 6	31 + 6	41 + 6	55 + 6

### DC VOLTS NOTES

- For T<sub>CAL</sub> ±1°C, following 55-minute warm-up. T<sub>CAL</sub> is ambient temperature at calibration, which is 23°C from factory.
- For T<sub>CAL</sub> ±5°C, following 55-minute warm-up. Specifications include factory traceability to US NIST.
- When properly zeroed using REL function.
- DCV Transfer Stability typical applications are standard cell comparisons and relative accuracy measurements. Specs apply for 10 power line cycles, 20-reading digital filter, autozero on with type synchronous, fixed range following 2-hour warm-up at full scale to 10% of full scale, at T<sub>REF</sub> ±1°C (T<sub>REF</sub> is the initial ambient temperature). Specifications on the 1000V range are for measurements within 5% of the initial measurement value and following measurement settling.

### AC VOLTS

#### Normal Mode RMS<sup>1</sup> 90 Days, ±2°C from last AC self-cal for 1% to 100% of range<sup>2</sup> ±(% of reading + % of range)

Range	20–50Hz	50–100Hz	0.1–2kHz	2–10kHz	10–30kHz	30–50kHz	50–100kHz	100–200kHz	0.2–1MHz	1–2MHz
200 mV	0.25 + 0.015	0.07 + 0.015	0.03 + 0.015	0.03 + 0.015	0.035 + 0.015	0.05 + 0.015	0.3 + 0.015	0.75 + 0.025	2 + 0.1	5 + 0.2
2 V	0.25 + 0.015	0.07 + 0.015	0.03 + 0.015	0.03 + 0.015	0.035 + 0.015	0.05 + 0.015	0.3 + 0.015	0.75 + 0.025	2 + 0.1	5 + 0.2
20 V	0.25 + 0.015	0.07 + 0.015	0.04 + 0.015	0.06 + 0.015	0.08 + 0.015	0.1 + 0.015	0.3 + 0.015	0.75 + 0.025	4 + 0.2	7 + 0.2 <sup>4</sup>
200 V <sup>3</sup>	0.25 + 0.015	0.07 + 0.015	0.04 + 0.015	0.06 + 0.015	0.08 + 0.015	0.1 + 0.015	0.3 + 0.015	0.75 + 0.025 <sup>4</sup>	4 + 0.2 <sup>4</sup>	
750 V <sup>3</sup>	0.25 + 0.015	0.1 + 0.015	0.08 + 0.015	0.09 + 0.015	0.12 + 0.015	0.15 + 0.015 <sup>4</sup>	0.5 + 0.015 <sup>4</sup>			

### AC VOLTS NOTES

- Specifications apply for sinewave input, AC + DC coupling, 1 power line cycle, digital filter off, following 55 minute warm-up.
- For 1% to 5% of range below 750V range, and for 1% to 7% of 750V range, add 0.01% to range uncertainty. For inputs from 200kHz to 2MHz, specifications apply above 10% of range.
- Add 0.001% of reading × (V<sub>IN</sub>/100V)<sup>2</sup> additional uncertainty above 100V rms.
- Typical values.

### OHMS

#### TWO-WIRE AND FOUR-WIRE OHMS (2W and 4W Ohms Functions)<sup>6</sup>

Range	Full Scale	Resolution	Default Resolution	Current Source <sup>1</sup>	Resistance Accuracy <sup>3</sup> ±(ppm of reading + ppm of range)			
					24 Hours <sup>4</sup>	90 Days <sup>5</sup>	1 Year <sup>5</sup>	2 Years <sup>5</sup>
					20 Ω	21.000000 Ω	1 μΩ	10 μΩ
200 Ω	210.00000 Ω	10 μΩ	100 μΩ	0.98 mA	24 + 7	36 + 7	56 + 7	90 + 7
2 kΩ	2100.0000 kΩ	100 μΩ	1 mΩ	0.98 mA	22 + 4	33 + 4	50 + 4	80 + 4.5
20 kΩ	21.000000 kΩ	1 mΩ	10 mΩ	89 μA	19 + 4	32 + 4	50 + 4	80 + 4.5
200 kΩ	210.000000 kΩ	10 mΩ	100 mΩ	7 μA	20 + 4.5	72 + 4.5	90 + 4.5	130 + 5
2 MΩ <sup>2</sup>	2.1000000 MΩ	100 mΩ	1 Ω	770 nA	50 + 4.5	110 + 4.5	160 + 4.5	230 + 5
20 MΩ <sup>2</sup>	21.000000 MΩ	1 Ω	10 Ω	70 nA	160 + 4.5	560 + 4.5	900 + 4.5	1100 + 5
200 MΩ <sup>2</sup>	210.000000 MΩ	10 Ω	100 Ω	4.4 nA	3000 + 100	10000 + 100	20000 + 100	30000 + 100
1 GΩ <sup>2</sup>	1.0500000 GΩ	100 Ω	1 kΩ	4.4 nA	9000 + 100	20000 + 100	40000 + 100	60000 + 100

### OHMS NOTES

- Current source is typically ±9% absolute accuracy.
- For 2-wire mode.
- Specifications are for 1 power line cycle, 10 reading digital filter, Auto Zero on, 4-wire mode, offset compensation on (for 20Ω to 20kΩ ranges).
- For T<sub>CAL</sub> ±1°C, following 55 minute warm-up. T<sub>CAL</sub> is ambient temperature at calibration (23°C at the factory).
- For T<sub>CAL</sub> ±5°C, following 55-minute warm-up. Specifications include traceability to US NIST.
- When measuring resistance of inductive loads, the inductance of that load must be 10mH or less.

### DC AMPS

#### DCI INPUT CHARACTERISTICS AND ACCURACY<sup>4</sup>

Range	Full Scale	Resolution	Default Resolution	Maximum Burden Voltage <sup>6</sup>	Accuracy <sup>1</sup> ±(ppm of reading + ppm of range)			
					24 Hours <sup>2</sup>	90 Days <sup>3</sup>	1 Year <sup>3</sup>	2 Years <sup>3</sup>
					200 μA	210.00000 μA	10 pA	100 pA
2 mA	2.1000000 mA	100 pA	1 nA	0.31 V	64 + 20	300 + 20	400 + 20	750 + 20
20 mA	21.000000 mA	1 nA	10 nA	0.4 V	65 + 20	300 + 20	400 + 20	750 + 20
200 mA	210.00000 mA	10 nA	100 nA	0.5 V	96 + 20	300 + 20	500 + 20	750 + 20
2 A	2.1000000 A	100 nA	1 μA	1.5 V	500 + 20	600 + 20	900 + 20	1350 + 20

### DC AMPS NOTES

- Specifications are for 1 power line cycle, Auto Zero on, 10 reading digital filter.
- For T<sub>CAL</sub> ±1°C, following 55 minute warm-up.
- For T<sub>CAL</sub> ±5°C, following 55 minute warm-up. Specifications include traceability to US NIST.
- Add 50 ppm of range for current above 0.5A for self heating.
- Actual maximum voltage burden = (maximum voltage burden) × (I<sub>MEASURED</sub>/I<sub>FULL SCALE</sub>).

1.888.KEITHLEY (U.S. only)

www.keithley.com

KEITHLEY

A Greater Measure of Confidence

A Tektronix Company

2001  
2002

# 7½-Digit High Performance Multimeter 8½-Digit High Performance Multimeter

## 2001 Condensed Specifications (continued)

### AC AMPS

#### ACI ACCURACY<sup>1,2</sup>

90 Days, 1 Year or 2 Years, T<sub>CAL</sub> ±5°C, for 5% to 100% of range, ±(% of reading + % of range)

RANGE	20Hz–50Hz	50Hz–200Hz	200Hz–1kHz	1kHz–10kHz	10kHz–30kHz <sup>3</sup>	30kHz–50kHz <sup>3</sup>	50kHz–100kHz <sup>3</sup>
200 μA	0.35 + 0.015	0.2 + 0.015	0.4 + 0.015	0.5 + 0.015			
2 mA	0.3 + 0.015	0.15 + 0.015	0.12 + 0.015	0.12 + 0.015	0.25 + 0.015	0.3 + 0.015	0.5 + 0.015
20 mA	0.3 + 0.015	0.15 + 0.015	0.12 + 0.015	0.12 + 0.015	0.25 + 0.015	0.3 + 0.015	0.5 + 0.015
200 mA	0.3 + 0.015	0.15 + 0.015	0.12 + 0.015	0.15 + 0.015	0.5 + 0.015	1 + 0.015	3 + 0.015
2 A	0.35 + 0.015	0.2 + 0.015	0.3 + 0.015	0.45 + 0.015	1.5 + 0.015	4 + 0.015	

### AC AMPS NOTES

- Specifications apply for sine wave input, AC+DC coupling, 1 power line cycle, digital filter off, following 55 minute warm-up.
- Add 0.005% of range uncertainty for current above 0.5A rms for self-heating.
- Typical values.

### FREQUENCY COUNTER

AC VOLTAGE INPUT: 1Hz–15MHz.

ACCURACY: ±(0.03% of reading).

### DC IN-CIRCUIT CURRENT

TYPICAL RANGES: Current: 100μA to 12A. Trace Resistance: 1mΩ to 10Ω typical.

ACCURACY: ±(5% + 2 counts). For 1 power line cycle, Auto Zero on, 10 reading digital filter, T<sub>CAL</sub> ±5°C, after being properly zeroed. 90 days, 1 year or 2 years.

### TEMPERATURE

Built-in linearization for J, K, N, T, E, R, S, B thermocouple types to ITS-90 and 100Ω platinum RTDs DIN 43 760 or IPTS-68.

### GENERAL

**POWER: Voltage:** 90–134V and 180–250V, universal self-selecting. **Frequency:** 50Hz, 60Hz, or 400Hz self-identifying. **Consumption:** <5VA.

**ENVIRONMENTAL: Operating Temperature:** 0° to 50°C. **Storage Temperature:** –40° to 70°C. **Humidity:** 80% R.H., 0° to 35°C, per MIL-T-28800E<sup>1</sup> Para 4.5.5.1.2.

**PHYSICAL: Case Dimensions:** 90mm high × 214mm wide × 369mm deep (3½ in. × 8½ in. × 14½ in.). **Net Weight:** <4.2kg (<9.2 lbs.). **Shipping Weight:** <9.1kg (<20 lbs.).

#### STANDARDS

**EMI/RFI:** Conforms to VDE 0871B (per Vfg 1046/1984), IEC 801-2. Meets FCC part 15 Class B, CISPR-22 (EN55022).

**Safety:** Conforms to IEC348, CAN/CSA-C22.2, No. 231, MIL-T-28800E<sup>1</sup>. Designed to UL1244.

**Note 1:** For MIL-T-28800E, applies to Type III, Class 5, Style E.

For complete specifications, refer to the 2001 Technical Data book.

## 2002 Condensed Specifications

### DC VOLTS

#### DCV INPUT CHARACTERISTICS AND ACCURACY

##### Enhanced Accuracy<sup>1</sup> – 10PLC, DFILT 10

##### Relative Accuracy ±(ppm of reading + ppm of range)

Range	Full Scale	Resolution	Input Resistance	Transfer <sup>5</sup>	24 Hours <sup>2</sup>	90 Days <sup>3</sup>	1 Year <sup>3</sup>	2 Years <sup>3</sup>
200mV <sup>4</sup>	±210.000000 mV	1 nV	>100 GΩ	0.4 + 1.5	3.5 + 3	15 + 8	19 + 9	23 + 10
2 V <sup>4</sup>	±2.10000000 V	10 nV	>100 GΩ	0.2 + 0.15	1.2 + 0.3	6 + 0.8	10 + 0.9	14 + 1
20 V	±21.00000000 V	100 nV	>100 GΩ	0.1 + 0.05	1.2 + 0.1	6 + 0.15	10 + 0.15	14 + 0.15
200 V	±210.00000000 V	1 μV	10 MΩ ±1%	0.5 + 0.08	5 + 0.4	14 + 2	22 + 2	30 + 2
1000 V <sup>6</sup>	±1100.000000 V	10 μV	10 MΩ ±1%	1 + 0.05	5 + 0.08	14 + 0.4	22 + 0.4	30 + 0.4

##### Normal Accuracy<sup>7</sup> – 1PLC, DFILT off

##### Relative Accuracy ±(ppm of reading + ppm of range)

Range	Full Scale	Resolution	Input Resistance	24 Hours <sup>2</sup>	90 Days <sup>3</sup>	1 Year <sup>3</sup>	2 Years <sup>3</sup>
200mV <sup>4</sup>	±210.000000 mV	10 nV	>100 GΩ	3.5 + 6	15 + 11	19 + 12	23 + 13
2 V <sup>4</sup>	±2.10000000 V	100 nV	>100 GΩ	1.2 + 0.6	6 + 1.1	10 + 1.2	14 + 1.3
20 V	±21.00000000 V	1 μV	>100 GΩ	3.2 + 0.35	8 + 0.4	12 + 0.4	16 + 0.4
200 V	±210.000000 V	10 μV	10 MΩ ±1%	5 + 1.2	14 + 2.8	22 + 2.8	30 + 2.8
1000 V <sup>6</sup>	±1100.000000 V	100 μV	10 MΩ ±1%	5 + 0.4	14 + 0.7	22 + 0.7	30 + 0.7

### DC VOLTS NOTES

- Specifications are for 10 power line cycles, synchronous autozero, 10-reading repeat digital filter, autorange off, except as noted.
- For T<sub>CAL</sub> ±1°C, following 4-hour warm-up. T<sub>CAL</sub> is ambient temperature at calibration (23°C at the factory). Add 0.5ppm of reading uncertainty if the unit is power cycled during this interval.
- For T<sub>CAL</sub> ±5°C, following 4-hour warm-up.
- Care must be taken to minimize thermal offsets due to operator cables.
- Specifications apply for 20-reading repeat digital filter, T<sub>REF</sub> ±0.5°C (T<sub>REF</sub> is the initial ambient temperature), and for measurements within 10% of the initial measurement value and within 10 minutes of the initial measurement time.
- Add 20ppm × (V<sub>IN</sub>/1000V)<sup>2</sup> additional uncertainty for inputs above 200V, except in transfer accuracy specifications.
- Specifications are for 1 power line cycle, normal autozero, digital filter off, autorange off.

### AC VOLTS Normal Mode RMS<sup>1</sup>

90 Days, 1 Year or 2 Years, ±2°C from last AC self-cal, for 1% to 100% of range<sup>2</sup> ±(% of reading + % of range)

Range	20–50Hz	50–100Hz	0.1–2kHz	2–10kHz	10–30kHz	30–50kHz	50–100kHz	100–200kHz	0.2–1MHz	1–2MHz
200 mV	0.25 + 0.015	0.07 + 0.015	0.02 + 0.02	0.02 + 0.02	0.025 + 0.02	0.05 + 0.01	0.3 + 0.015	0.75 + 0.025	2 + 0.1	5 + 0.2
2 V	0.25 + 0.015	0.07 + 0.015	0.02 + 0.02	0.02 + 0.02	0.025 + 0.02	0.05 + 0.01	0.3 + 0.015	0.75 + 0.025	2 + 0.1	5 + 0.2
20 V	0.25 + 0.015	0.07 + 0.015	0.03 + 0.015	0.04 + 0.015	0.05 + 0.015	0.07 + 0.015	0.3 + 0.015	0.75 + 0.025	4 + 0.2	7 + 0.2 <sup>4</sup>
200 V <sup>3</sup>	0.25 + 0.015	0.07 + 0.015	0.03 + 0.015	0.04 + 0.015	0.05 + 0.015	0.07 + 0.015	0.3 + 0.015	0.75 + 0.025 <sup>4</sup>	4 + 0.2 <sup>4</sup>	
750 V <sup>3</sup>	0.25 + 0.015	0.1 + 0.015	0.05 + 0.015	0.06 + 0.015	0.08 + 0.015	0.1 + 0.015 <sup>4</sup>	0.5 + 0.015 <sup>4</sup>			

### AC VOLTS NOTES

- Specifications apply for sine wave input, AC + DC coupling, 1 power line cycle, autozero on, digital filter off, following 55-minute warm-up.
- For 1% to 5% of range below 750V range, and for 1% to 7% of 750V range, add 0.01% of range uncertainty. For inputs from 200kHz to 2MHz, specifications apply above 10% of range.
- Add 0.001% of reading × (V<sub>IN</sub>/100V)<sup>2</sup> additional uncertainty for inputs above 100V rms.
- Typical values.

1.888.KEITHLEY (U.S. only)

www.keithley.com

A Greater Measure of Confidence

KEITHLEY

A Tektronix Company



# 2001 2002

# 7½-Digit High Performance Multimeter 8½-Digit High Performance Multimeter

## 2002 Condensed Specifications (continued)

### OHMS

#### TWO-WIRE AND FOUR-WIRE OHMS

Range	Full Scale	Resolution	Current Source <sup>1</sup>	Relative Accuracy <sup>3</sup> ±(ppm of reading + ppm of range)				
				Transfer <sup>7</sup>	24 Hours <sup>4</sup>	90 Days <sup>5</sup>	1 Year <sup>5</sup>	2 Years <sup>5</sup>
20 Ω	21.000000 Ω	100 nΩ	7.2 mA	2.5 + 3	5 + 4.5	15 + 6	17 + 6	20 + 6
200 Ω	210.00000 Ω	1 μΩ	960 μA	2.5 + 2	5 + 3	15 + 4	17 + 4	20 + 4
2 kΩ	2100.0000 kΩ	10 μΩ	960 μA	1.3 + 0.2	2.5 + 0.3	7 + 0.4	9 + 0.4	11 + 0.4
20 kΩ	21.000000 kΩ	100 μΩ	96 μA	1.3 + 0.2	2.5 + 0.3	7 + 0.4	9 + 0.4	11 + 0.4
200 kΩ	210.00000 kΩ	1 mΩ	9.6 μA	2.5 + 0.4	5.5 + 0.5	29 + 0.8	35 + 0.9	40 + 1
2 MΩ	2.1000000 MΩ	10 mΩ	1.9 μA	5 + 0.2	12 + 0.3	53 + 0.5	65 + 0.5	75 + 0.5
20 MΩ <sup>2</sup>	21.000000 MΩ	100 mΩ	1.4 μA <sup>6</sup>	15 + 0.1	50 + 0.2	175 + 0.6	250 + 0.6	300 + 0.6
200 MΩ <sup>2</sup>	210.00000 MΩ	1 Ω	1.4 μA <sup>6</sup>	50 + 0.5	150 + 1	500 + 3	550 + 3	600 + 3
1 GΩ <sup>2</sup>	1.0500000 GΩ	10 Ω	1.4 μA <sup>6</sup>	250 + 2.5	750 + 5	2000 + 15	2050 + 15	2100 + 15

### OHMS NOTES

- Current source has an absolute accuracy of ±5%.
- For 2-wire mode.
- Specifications are for 10 power line cycles, 10-reading repeat digital filter, synchronous autozero, autorange off, 4-wire mode, offset compensation on (for 20Ω to 20kΩ ranges), except as noted.
- For T<sub>CAL</sub> ±1°C, following 4-hour warm-up. T<sub>CAL</sub> is ambient temperature at calibration (23°C at the factory).
- For T<sub>CAL</sub> ±5°C, following 4-hour warm-up.
- Current source is paralleled with a 10MΩ resistance.
- Specifications apply for 20-reading repeat digital filter. T<sub>REF</sub> ±0.5°C (T<sub>REF</sub> is the initial ambient temperature), and for measurements within 10% of the initial measurement value and within 10 minutes of the initial measurement time.

### DC AMPS

#### DCI INPUT CHARACTERISTICS AND ACCURACY

Range	Full Scale	Resolution	Maximum Burden Voltage <sup>3</sup>	Relative Accuracy ±(ppm of reading + ppm of range)			
				24 Hours <sup>1</sup>	90 Days <sup>2</sup>	1 Year <sup>2</sup>	2 Years <sup>2</sup>
200 μA	210.00000 μA	10 pA	0.25 V	50 + 6	275 + 25	350 + 25	500 + 25
2 mA	2.1000000 mA	100 pA	0.3 V	50 + 5	275 + 20	350 + 20	500 + 20
20 mA	21.000000 mA	1 nA	0.35 V	50 + 5	275 + 20	350 + 20	500 + 20
200 mA	210.00000 mA	10 nA	0.35 V	75 + 5	300 + 20	375 + 20	525 + 20
2 A	2.1000000 A	100 nA	1.1 V	350 + 5	600 + 20	750 + 20	1000 + 20

### DC AMPS NOTES

- For T<sub>CAL</sub> ±1°C, following 55-minute warm-up. T<sub>CAL</sub> is ambient temperature at calibration (23°C at the factory).
- For T<sub>CAL</sub> ±5°C, following 55-minute warm-up.
- Actual maximum burden voltage = (maximum burden voltage) × (I<sub>MEASURED</sub><sup>1</sup> / I<sub>FULLSCALE</sub><sup>1</sup>).

### AC AMPS

Range	ACI Accuracy <sup>1,2</sup> 90 Days, 1 Year or 2 Years, T <sub>CAL</sub> ±5°C, for 5% to 100% of range, ±(% of reading + % of range)						
	20Hz–50Hz	50Hz–200Hz	200Hz–1kHz	1kHz–10kHz	10kHz–30kHz <sup>3</sup>	30kHz–50kHz <sup>3</sup>	50kHz–100kHz <sup>3</sup>
200 μA	0.35 + 0.015	0.2 + 0.015	0.4 + 0.015	0.5 + 0.015			
2 mA	0.3 + 0.015	0.15 + 0.015	0.12 + 0.015	0.12 + 0.015	0.25 + 0.015	0.3 + 0.015	0.5 + 0.015
20 mA	0.3 + 0.015	0.15 + 0.015	0.12 + 0.015	0.12 + 0.015	0.25 + 0.015	0.3 + 0.015	0.5 + 0.015
200 mA	0.3 + 0.015	0.15 + 0.015	0.12 + 0.015	0.15 + 0.015	0.5 + 0.015	1 + 0.015	3 + 0.015
2 A	0.35 + 0.015	0.2 + 0.015	0.3 + 0.015	0.45 + 0.015	1.5 + 0.015	4 + 0.015	

### AC AMPS NOTES

- Specifications apply for sinewave input, AC+DC coupling, 1 power line cycle, autozero on, digital filter off, following 55-minute warm-up.
- Add 0.005% of range uncertainty for current above 0.5A rms for self-heating.
- Typical values.

### FREQUENCY COUNTER

AC VOLTAGE INPUT: 1Hz–15 MHz.

ACCURACY: ±(0.03% of reading).

### DC IN-CIRCUIT CURRENT

TYPICAL RANGES: Current: 100μA to 12A. Trace Resistance: 1mΩ to 10Ω.

ACCURACY: ±(5% + 500μA). For 1 power line cycle, autozero on, 10-reading digital filter, T<sub>CAL</sub> ±5°C, 90 days, 1 year or 2 years.

### TEMPERATURE

Built-in linearization for J, K, N, T, E, R, S, B thermocouple types to ITS-90 and 100Ω platinum RTDs DIN 43760, IPTS-68, and ITS-90.

### GENERAL

**POWER: Voltage:** 90–134V and 180–250V, universal self-selecting. **Frequency:** 50Hz, 60Hz, or 400Hz self-identifying at power-up. **Consumption:** <55VA.

**ENVIRONMENTAL: Operating Temperature:** 0° to 50°C. **Storage Temperature:** –40° to 70°C. **Humidity:** 80% R.H., 0° to 35°C.

**PHYSICAL: Case Dimensions:** 90mm high × 214mm wide × 369mm deep (3½ in. × 8½ in. × 14½ in.). **Net Weight:** <4.2kg (<9.2 lbs.). **Shipping Weight:** <9.1kg (<20 lbs.).

#### STANDARDS

**EMI/RFI:** Conforms to European Union EMC directive.

**Safety:** Conforms to European Union Low Voltage directive.

**Note 1:** For MIL-T-28800E, applies to Type III, Class 5, Style E.

1.888.KEITHLEY (U.S. only)

[www.keithley.com](http://www.keithley.com)

**KEITHLEY**

A Greater Measure of Confidence

A Tektronix Company

# 2010

## Low Noise 7½-Digit Autoranging Multimeter



- 7½-digit resolution
- 100nV rms noise floor
- 7ppm DCV repeatability
- Built-in 10-channel scanner mainframe
- Dry circuit and low power measurement mode
- 15 measurement functions including support for RTD and thermocouple temperature measurements
- Built-in ratio measurement function
- GPIB and RS-232 interfaces

### Ordering Information

2010 Autoranging DMM

#### Accessories Supplied

Model 1751 Safety Test Leads, User Manual, Service Manual

### SERVICES AVAILABLE

2000-SCAN-3Y-EW	1-year factory warranty extended to 3 years from date of shipment
2001-TCSCAN-3Y-EW	1-year factory warranty extended to 3 years from date of shipment
2010-3Y-EW	1-year factory warranty extended to 3 years from date of shipment
C/2000-3Y-ISO	3 (ISO-17025 accredited) calibrations within 3 years of purchase for Model 2000-SCAN*
C/2001-3Y-ISO	3 (ISO-17025 accredited) calibrations within 3 years of purchase for Model 2001-TCSCAN*
C/2010-3Y-ISO	3 (ISO-17025 accredited) calibrations within 3 years of purchase for Model 2010*

\*Not available in all countries

1.888.KEITHLEY (U.S. only)

www.keithley.com

The 7½-digit Model 2010 Low Noise Multimeter combines high resolution with the high speed and accuracy needed for production applications such as testing precision sensors, transducers, A/D and D/A converters, regulators, references, connectors, switches, and relays. It is based on the same high speed, low noise A/D converter technology as the Models 2000, 2001, and 2002.

### High Measurement Flexibility

The 2010 has 15 built-in measurement functions, including DCV, ACV, DCI, ACI, 2WΩ, 4WΩ, dry circuit resistance, temperature (with either thermocouples or RTDs), frequency, period, ratio, continuity measurement, and diode testing. This multi-functional design minimizes added equipment costs.

Creating a self-contained multipoint measurement solution is as simple as plugging a 2000-SCAN or 2001-TCSCAN scanner card into the option slot in the 2010's back panel. This "plug-in" approach eliminates the need for a separate scanner and significantly reduces programming and setup time in applications involving a limited number of test points. For larger applications, the 2010 is compatible with Keithley's Series 7000 switch matrices and cards.

### Unique Resistance Measurement Functions

Characterizing the resistance, linearity, or isolation of contacts, connectors, switches, or relays completely and efficiently demands an uncommon combination of ohms measurement capabilities. The 2010 offers:

- **Low-power ohms measurement mode.** Low-level resistance measurements can be made with source current as low as 100μA, an order of magnitude lower than is possible with other DMMs, so device self-heating is minimized. Among other benefits, this low-power measurement capability makes the 2010 suitable for end-of-life contact testing per ASTM B539-90.
- **Dry circuit test function.** When measuring contact and connector resistances, it is important to control the test voltage carefully in order to avoid puncturing any oxides or films that may have formed. A built-in clamp limits the open circuit test voltage to 20mV to ensure dry circuit conditions.
- **Offset compensated ohms function.** This function eliminates thermal effects that can create errors in low-level resistance measurements in system environments.
- **Extended ohms measurement capability.** The 2010 provides a 10Ω range for more precise measurements of low resistances.

### Optional Multiplexer Cards

Creating a self-contained multipoint measurement solution is as simple as plugging a scanner card into the option slot on the 2010's back panel. This approach eliminates the complexities of triggering, timing, and processing issues and helps reduce test time significantly. For applications involving more than 10 measurement points, the 2010 is compatible with Keithley's Series 7000 switch matrices and cards.

### Model 2000-SCAN Scanner Card

- Ten analog input channels (2-pole)
- Configurable as 4-pole, 5-channel

### ACCESSORIES AVAILABLE

#### TEST LEADS

5804/5 4-Wire/Kelvin Test Lead Sets

#### SWITCH/SCANNER CARDS

2000-SCAN 10-channel Scanner

2001-TCSCAN 9-channel Thermocouple Scanner

#### CABLES/ADAPTERS

7007-1 Shielded IEEE-488 Cable, 1m (3.3 ft)

7007-2 Shielded IEEE-488 Cable, 2m (6.6 ft)

7009-5 RS-232 Cable

#### RACK MOUNT KITS

4288-1 Single Fixed Rack Mount Kit

4288-2 Dual Fixed Rack Mount Kit

#### GPIB INTERFACES

KPCI-488LPA IEEE-488 Interface/Controller for the PCI Bus

KUSB-488B IEEE-488 USB-to-GPIB Interface Adapter

DMM optimized for resistance measurement applications

DIGITAL MULTIMETERS & SYSTEMS

2010

# Low Noise 7½-Digit Autoranging Multimeter

Model 2010 specifications

DIGITAL MULTIMETERS & SYSTEMS

## DC VOLTAGE

Range	Resolution	Accuracy 23°C ± 5°C ±(ppm of rdg. + ppm of range)		Input Resistance
		90 Day	1 Year	
100.00000 mV	10 nV	25 + 9	37 + 9	> 10 GΩ
1.0000000 V	100 nV	18 + 2	25 + 2	> 10 GΩ
10.000000 V	1 μV	18 + 4	24 + 4	> 10 GΩ
100.00000 V	10 μV	25 + 5	35 + 5	10 MΩ ±1%
1000.0000 V	100 μV	31 + 6	41 + 6	10 MΩ ±1%

## RESISTANCE

Range	Resolution	Accuracy 23°C ± 5°C ±(ppm of rdg. + ppm of range)		Test Current
		90 Day	1 Year	
10.000000 Ω	1 μΩ	40 + 9	60 + 9	10 mA
100.00000 Ω	10 μΩ	36 + 9	52 + 9	1 mA
1.0000000 kΩ	100 μΩ	33 + 2	50 + 2	1 mA
10.000000 kΩ	1 mΩ	32 + 2	50 + 2	100 μA
100.00000 kΩ	10 mΩ	40 + 4	70 + 4	10 μA
1.0000000 MΩ	100 mΩ	50 + 4	70 + 4	10 μA
10.000000 MΩ	1 Ω	200 + 4	400 + 4	640 nA/10 MΩ
100.00000 MΩ	10 Ω	1500 + 4	1500 + 4	640 nA/10 MΩ

## DC CURRENT

Range	Resolution	Accuracy 23°C ± 5°C ±(ppm of rdg. + ppm of range)		Burden Voltage
		90 Day	1 Year	
10.000000 mA	1 nA	300 + 80	500 + 80	< 0.15 V
100.00000 mA	10 nA	300 + 800	500 + 800	< 0.18 V
1.0000000 A	100 nA	500 + 80	800 + 80	< 0.35 V
3.000000 A	1 μA	1200 + 40	1200 + 40	< 1 V

## CONTINUITY 2W

Range	Resolution	Accuracy 23°C ± 5°C ±(ppm of rdg. + ppm of range)		Test Current
		90 Day	1 Year	
1 kΩ	100 mΩ	100 + 100	120 + 100	1 mA

## DIODE TEST

Range	Resolution	Accuracy 23°C ± 5°C ±(ppm of rdg. + ppm of range)		Test Current
		90 Day	1 Year	
10.000000 V	1 μV	30 + 7	40 + 7	1 mA
4.400000 V	1 μV	30 + 7	40 + 7	100 μA
10.000000 V	1 μV	30 + 7	40 + 7	10 μA

## DC OPERATING CHARACTERISTICS

Function	Digits	Readings/s	PLCs
	7½	4 (3)	5
	6½	30 (27)	1
DCV (all ranges), DCI (all ranges), and Ohms (<10M range)	6½	50 (44)	1
	5½	260 (220)	0.1
	5½	490 (440)	0.1
	5½	1000 (1000)	0.04
	4½	2000 (1800)	0.01

## DC NOISE PERFORMANCE

Rate	Digits	RMS Noise 100mV Range (2 min.)	RMS Noise 10V Range (2 min.)	NMRR	CMRR
5 PLC	7½	110 nV	1.2 μV	60 dB	140 dB
1 PLC	6½	125 nV	1.4 μV	60 dB	140 dB
0.1 PLC	5½	1.9 μV	11.5 μV	—	80 dB
0.01 PLC	4½	2.9 μV	139 μV	—	80 dB

## TRUE RMS AC VOLTAGE AND CURRENT CHARACTERISTICS

Voltage Range	Resolution	Frequency Range	Accuracy (1 Year) 23°C ± 5°C ±(% of reading + % of range)	
			3 Hz–10 Hz	0.35 + 0.03
100 mV to 750 V	0.1 μV to 1 mV	10 Hz–20 kHz	0.06 + 0.03	
		20 kHz–50 kHz	0.12 + 0.05	
		50 kHz–100 kHz	0.60 + 0.08	
		100 kHz–300 kHz	4 + 0.5	

## AC OPERATING CHARACTERISTICS

Function	Digits	Readings/s	Rate	Bandwidth
	6½	0.5 (0.4)	SLOW	3 Hz–300 kHz
ACV (all ranges), and ACI (all ranges)	6½	1.4 (1.5)	MED	30 Hz–300 kHz
	6½	4.0 (4.3)	MED	30 Hz–300 kHz
	6½	2.2 (2.3)	FAST	300 Hz–300 kHz
	6½	35 (30)	FAST	300 Hz–300 kHz

## FREQUENCY AND PERIOD CHARACTERISTICS

ACV Range	Frequency Range	Period Range	Gate Time	Resolution ±(ppm of reading)	Accuracy 90 Day/1 Year ±(% of reading)
100 mV to 750 V	3 Hz to 500 kHz	333 ms to 2 μs	1 s	0.3	0.01

## TEMPERATURE CHARACTERISTICS

### Thermocouple

Type	Range	Resolution	Accuracy <sup>1</sup> 90 Day/1 Year (23°C ± 5°C) Relative to Reference Junction		USING 2001-TCSCAN <sup>2</sup>
			Reference Junction	2001-TCSCAN <sup>2</sup>	
J	-200 to + 760°C	0.001°C	±0.5°C	±0.65°C	
K	-200 to + 1372°C	0.001°C	±0.5°C	±0.70°C	
N	-200 to + 1300°C	0.001°C	±0.5°C	±0.70°C	
T	-200 to + 400°C	0.001°C	±0.5°C	±0.68°C	

### 4-WIRE RTD

Range	Resolution	Accuracy <sup>3</sup> 90 Day/1 Year (23°C ± 5°C)	Accuracy <sup>3</sup> 2 Years (23°C ± 5°C)
-100° to +100°C	0.001°C	±0.08°C	±0.12°C
-200° to +630°C	0.001°C	±0.14°C	±0.18°C

## TEMPERATURE NOTES

- For temperatures <-100°C, add ±0.1°C and >900°C add ±0.3°C.
- Specifications apply to channels 2–6. Add 0.06°C/channel from channel 6.
- Excluding probe errors.

## GENERAL

POWER SUPPLY: 100V / 120V / 220V / 240V.

LINE FREQUENCY: 50Hz to 60Hz and 440Hz, automatically sensed at power-up.

POWER CONSUMPTION: 22VA.

VOLT HERTZ PRODUCT: ≤8 × 10<sup>6</sup> V·Hz.

OPERATING ENVIRONMENT: Specified for 0° to 50°C. Specified to 80% R.H. at 35°C.

STORAGE ENVIRONMENT: -40° to 70°C.

ALTITUDE: Up to 2000 meters.

SAFETY: Conforms to European Union Directive 73/23/EEC EN 61010-1, Cat II.

EMC: Complies with European Union Directive 89/336/EEC, EN 61326-1.

VIBRATION: MIL-PRF-28800F Class 3 Random.

WARMUP: 2 hours to rated accuracy.

### DIMENSIONS:

Rack Mounting: 89mm high × 213mm wide × 370mm deep (3½ in × 8½ in × 14½ in).

Bench Configuration (with handle and feet): 104mm high × 238mm wide × 370mm deep (4½ in × 9½ in × 14½ in).

SHIPPING WEIGHT: 5kg (11 lbs).

1.888.KEITHLEY (U.S. only)

www.keithley.com

KEITHLEY

A Greater Measure of Confidence

A Tektronix Company

**2015, 2015-P,  
2016, 2016-P**

# 6½-Digit THD Multimeters 6½-Digit Audio Analyzing Multimeters



- THD, THD+Noise, and SINAD measurements
- 20Hz–20kHz sine wave generator
- Fast frequency sweeps
- 2015-P, 2016-P: Identifies peak spectral components
- 2015, 2015-P: 4Vrms single-ended or 8Vrms differential output
- 2016, 2016-P: 9.5Vrms single-ended or 19Vrms differential output
- Individual harmonic magnitude measurements
- 5 standard audio shaping filters
- 13 DMM functions (6½ digits)
- GPIB and RS-232 interfaces

## APPLICATIONS

- Wireless communication device audio quality testing
- Component linearity testing
- Lighting and ballast THD limit conformance testing
- Telephone and automotive speaker testing

The Models 2015-P and 2016-P Audio Analyzing Digital Multimeters and the Models 2015 and 2016 Total Harmonic Distortion Multimeters combine audio band quality measurements and analysis with a full-function 6½-digit DMM. Test engineers can make a broad range of voltage, resistance, current, frequency, and distortion measurements, all with the same compact, half-rack measurement instrument. The Model 2016 and 2016-P have twice the sine wave generator output of the Model 2015 for applications that require test signals greater than 8Vrms. The Model 2015-P and 2016-P offer additional processing capacity for frequency spectrum analysis.

## Frequency Domain Distortion Analysis

For applications such as assessing non-linear distortion in components, devices, and systems, DSP-based processing allows the Models 2015-P, 2015, 2016, and 2016-P to provide frequency domain analysis in conventional time domain instruments. They

can measure Total Harmonic Distortion (THD) over the complete 20Hz to 20kHz audio band. They also measure over a wide input range (up to 750Vrms) and have low residual distortion (–87dB). The THD reading can be expressed either in decibels or as a percentage.

In addition to THD, the Models 2015, 2015-P, 2016, and 2016-P can compute THD+Noise and Signal-to-Noise plus Distortion (SINAD). For analyses in which the individual harmonics are the criteria of greatest interest, the instruments can report any of the (up to 64) harmonic magnitudes that can be included in the distortion measurements. The user can program the actual number of harmonics to be included in a computation, so accuracy, speed, and complexity can be optimized for a specific application. (See *Figure 1*.)

**Figure 1. Frequency Spectrum of 1kHz Square Wave**

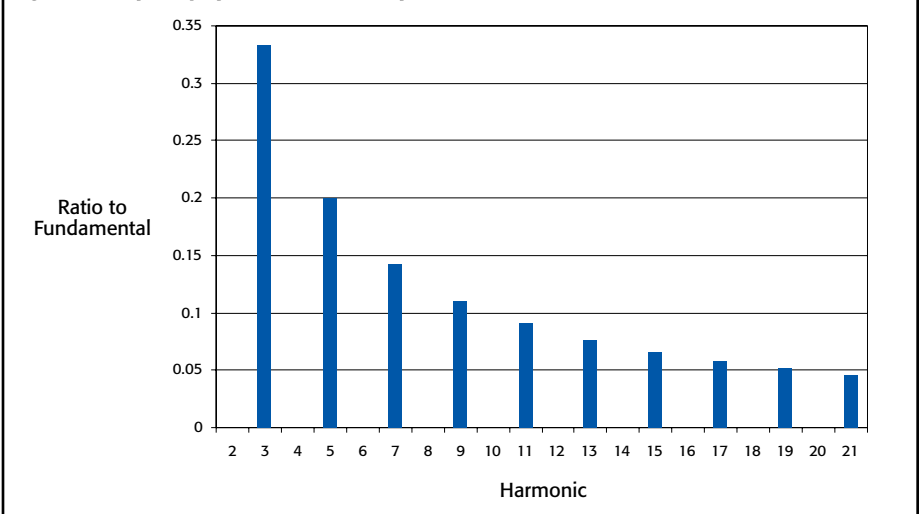

*Figure 1* shows a plot of a square wave's harmonics (frequency components) computed and transmitted to a personal computer by the Model 2015 or 2016. A square wave's spectral content consists of only odd harmonics whose magnitudes are (1/harmonic number × the magnitude of the fundamental). For example, the magnitude of the third harmonic is 1/3 the magnitude of the fundamental.

1.888.KEITHLEY (U.S. only)

[www.keithley.com](http://www.keithley.com)

A Greater Measure of Confidence

**KEITHLEY**

A Tektronix Company

# 2015, 2015-P, 2016, 2016-P

## Ordering Information

2015	Total Harmonic Distortion 6½-Digit Multimeter
2015-P	Audio Analyzing DMM
2016	Total Harmonic Distortion 6½-Digit DMM w/9V Source Output
2016-P	Audio Analyzing DMM w/9V Source Output

## Accessories Supplied

Model 1751 Safety Test Leads, User Manual, Service Manual.

**Figure 2. Total Harmonic Distortion Analysis and Frequency Response of a Portable Wireless Telecommunication Device** Device Under Test

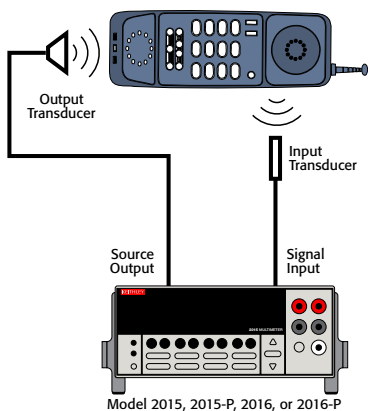

Figures 2, 3, and 4 demonstrate how the Model 2015, 2015-P, 2016, or 2016-P can provide both time domain and frequency domain measurements in a single test protocol. Figure 2 shows a sample test system schematic with a telecommunication device in a loop back mode test. The Audio Analyzing DMM's source provides a stimulus frequency sweep, and the Audio Analyzing DMM measures the response from the microphone circuit. Figure 3 shows the resulting frequency domain analysis of the THD and the first three harmonics as a function of frequency. Figure 4 shows the time domain analysis of microphone circuit output voltage as a function of frequency.

# 6½-Digit THD Multimeters 6½-Digit Audio Analyzing Multimeters

**Figure 3. THD and 2nd, 3rd, and 4th Harmonics as a Function of Frequency**

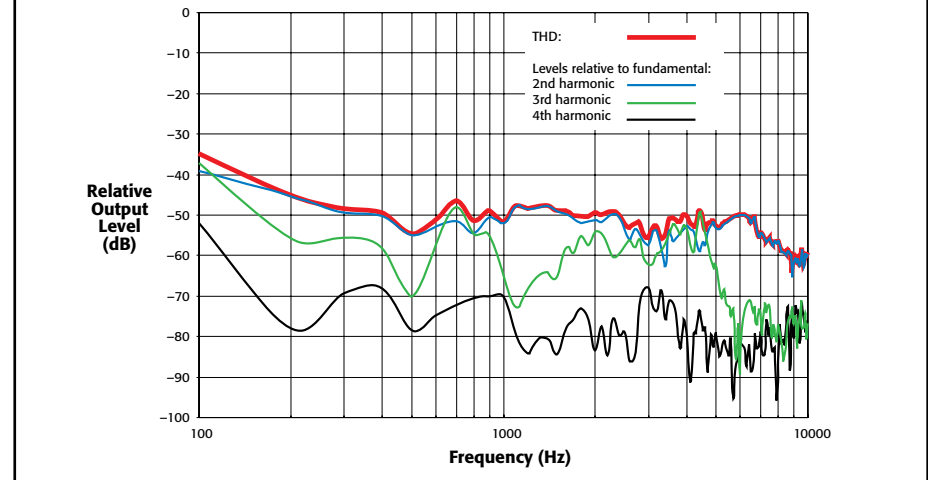

**Figure 4. Frequency Response**

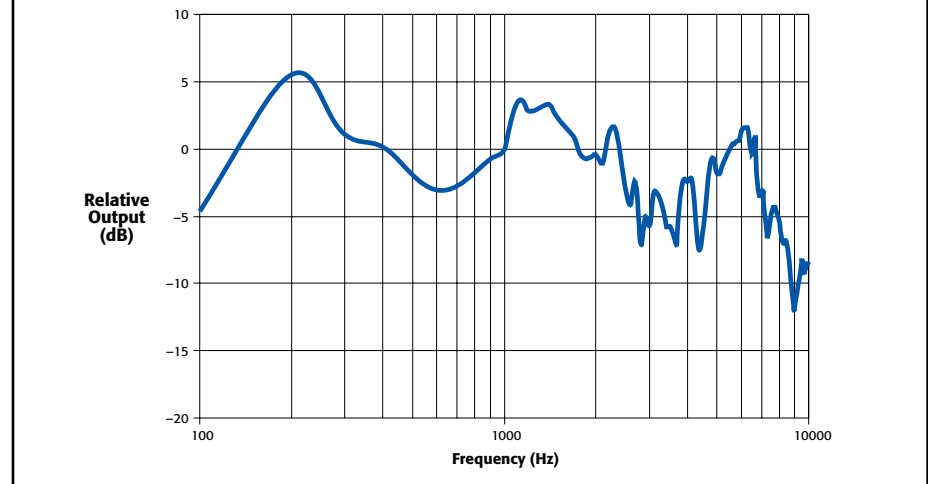

## Optimized for Production Testing

The Models 2015, 2015-P, 2016, and 2016-P can perform fast frequency sweeps for characterizing audio-band circuitry in production test systems. For example, the instruments can execute a single sweep of 30 frequencies and transmit both rms voltage readings and THD readings to a computer in only 1.1 seconds. With that data, a complete frequency response analysis and a harmonic distortion vs. frequency analysis can be performed in a very short time. Thus high speed testing of the audio performance of a high volume device such as a cellular telephone can be performed without reducing the number of tests or reducing the measurements in each test. With these instruments, which are optimized for production testing, test engineers can lower test times, in comparison to test speeds achievable with general purpose audio analyzers, without sacrificing production test quality.

## Dual Output Source

The Models 2015, 2015-P, 2016, and 2016-P include an internal audio band sine wave source for generating stimulus signals. A second output, the inverse of the first output, is also available, simplifying the testing of differential input circuits for common mode or noise cancellation performance.

1.888.KEITHLEY (U.S. only)

[www.keithley.com](http://www.keithley.com)

**KEITHLEY**

A Greater Measure of Confidence

A Tektronix Company

**2015, 2015-P,  
2016, 2016-P**

# 6½-Digit THD Multimeters 6½-Digit Audio Analyzing Multimeters

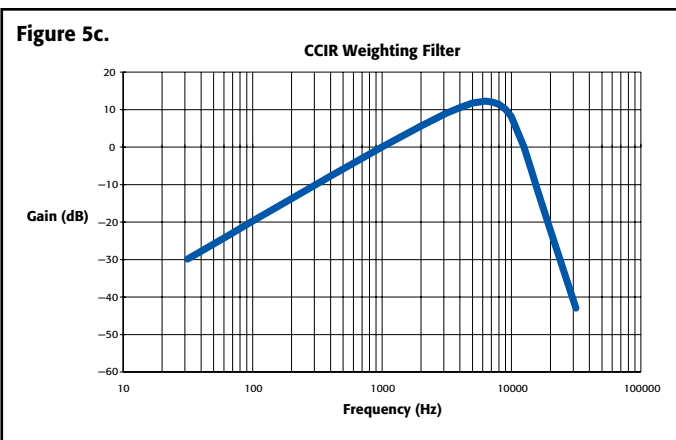
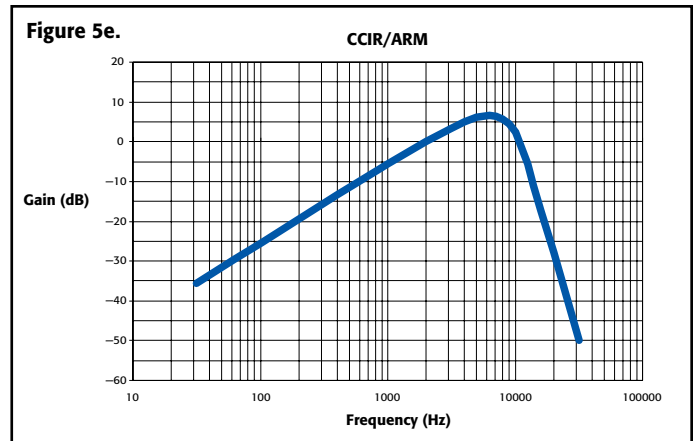
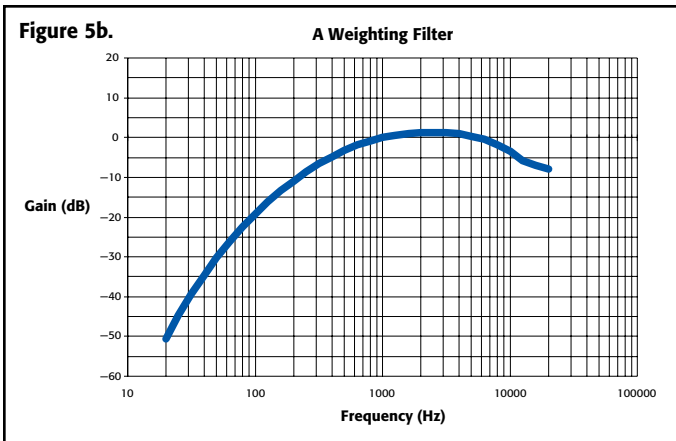
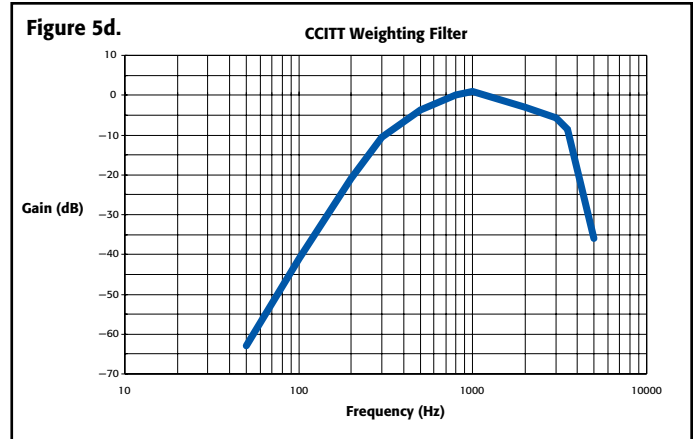
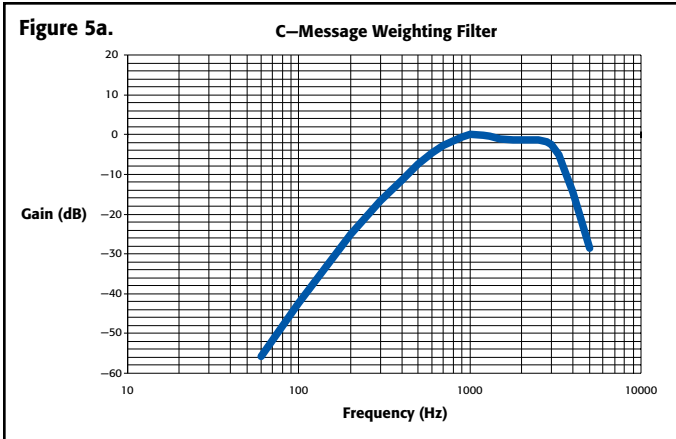

The Models 2015 and 2015-P have a 4Vrms single-ended output and 8Vrms differential source output. For tests that require a higher stimulus signal, the Model 2016 and 2016-P provide a 9.5Vrms single-ended output and a 19Vrms differential output.

### Wide Selection of Audio Filters

Five industry-standard bandpass filters are provided for shaping the input signal for audio and telecommunication applications. Available filters include the CCITT weighting filter, CCIR filter, C-message filter, CCIR/ARM filter, and "A" weighting filter (see *Figures 5a–5e*). The Models 2015, 2015-P, 2016, and 2016-P provide programmable, high cutoff (low pass) and low cutoff (high pass) filters. Furthermore, the two filters can be implemented together to form a bandpass filter. The programmable filters can be used to filter out noise generated by electromechanical machinery on the production floor or to simulate other types of system transmission characteristics.

### Broad Measurement Flexibility

In addition to their THD, THD+Noise, SINAD, and individual harmonic measurement capabilities, the instruments provide a comprehensive set of DMM functions, including DCV, ACV, DCI, ACI, 2WΩ, 4WΩ, temperature, frequency, period, dB, dBm, and continuity measurements, as well as diode testing. This multi-functional design minimizes added equipment costs when configuring test setups.

1.888.KEITHLEY (U.S. only)

[www.keithley.com](http://www.keithley.com)

**KEITHLEY**

A Greater Measure of Confidence

A Tektronix Company

# 2015, 2015-P, 2016, 2016-P

# 6½-Digit THD Multimeters 6½-Digit Audio Analyzing Multimeters

## Wide Band or Narrow Band Noise Measurements

The Models 2015, 2015-P, 2016, and 2016-P are capable of measuring both wide band noise and narrow band noise. Alternatively, these instruments' DSP (digital signal processing) capabilities allow users to make frequency domain measurements of RMS voltage noise over the 20Hz–20kHz frequency audio band or a narrow portion of the band. Furthermore, noise measurements can be extracted in the presence of a stimulus signal for fast signal-to-noise computations.

## Spectrum Analysis

The Model 2015-P and 2016-P have internal computational capabilities that allow them to characterize an acquired signal spectrum. These instruments can identify and report the frequency and amplitude of the highest value in a complete spectrum or within a specified frequency band. It can also identify additional peaks in descending order of magnitude (see **Figure 6**). The Model 2015-P's and 2016-P's on-board capabilities make it simple to obtain a thorough analysis of a frequency spectrum more quickly and with little or no need for external analysis software.

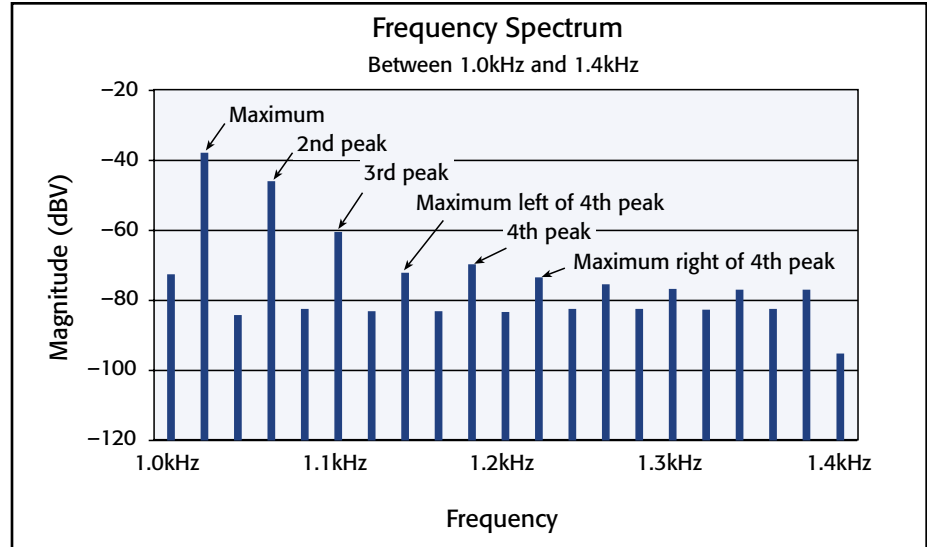

**Figure 6.** The Model 2015-P and 2016-P directly identify peak values of the frequency spectrum.



**Figure 7.** Rear panel of all models

## SERVICES AVAILABLE

2015-3Y-EW	1-year factory warranty extended to 3 years from date of shipment
2015-P-3Y-EW	1-year factory warranty extended to 3 years from date of shipment
2016-3Y-EW	1-year factory warranty extended to 3 years from date of shipment
2016-P-3Y-EW	1-year factory warranty extended to 3 years from date of shipment
C/2015-3Y-ISO	3 (ISO-17025 accredited) calibrations within 3 years of purchase for Models 2015, 2015-P*
C/2016-3Y-ISO	3 (ISO-17025 accredited) calibrations within 3 years of purchase for Models 2016, 2016-P*

\*Not available in all countries

## ACCESSORIES AVAILABLE

### CABLES/ADAPTERS

7007-1	Shielded IEEE-488 Cable, 1m (3.3 ft)
7007-2	Shielded IEEE-488 Cable, 2m (6.6 ft)
8501-1, 8501-2	Trigger-Link Cables, 1m (3.3 ft), 2m (6.6 ft)
8502	Trigger Link Adapter Box
8503	Trigger Link Cable to 2 male BNCs, 1m (3.3 ft)
7009-5	RS-232 Cable

### RACK MOUNT KITS

4288-1	Single Fixed Rack Mount Kit
4288-2	Dual Fixed Rack Mount Kit

### GPIB INTERFACES

KPCI-488LPA	IEEE-488 Interface/Controller for the PCI Bus
KUSB-488B	IEEE-488 USB-to-GPIB Interface Adapter

1.888.KEITHLEY (U.S. only)

[www.keithley.com](http://www.keithley.com)

**KEITHLEY**

A Greater Measure of Confidence

A Tektronix Company

**2015, 2015-P,  
2016, 2016-P**

# 6½-Digit THD Multimeters 6½-Digit Audio Analyzing Multimeters

## DISTORTION CHARACTERISTICS

**VOLTAGE RANGE:** 100mV, 1V, 10V, 100V, 750V (user selectable).  
**INPUT IMPEDANCE:** 1MΩ paralleled by <100pF.  
**DISPLAY RANGE:** 0–100% or 0–100.00dB.  
**RESOLUTION:** 0.0001% or 0.00001dB.  
**FUNDAMENTAL FREQUENCY RANGE:** 20Hz–20kHz.  
**HARMONIC FREQUENCY RANGE:** 40Hz–50kHz.  
**FREQUENCY RESOLUTION:** 0.008Hz.  
**FREQUENCY ACCURACY:** ±0.01% of reading.  
**FREQUENCY TEMPERATURE COEFFICIENT:** ≤100ppm over operating temperature range.

Measurement Mode	Accuracy (1 Year, 23°C ±5°C)	Residual Distortion <sup>1</sup>
THD and individual harmonic magnitudes	±0.8 dB, 20 Hz to 20 kHz <sup>2</sup>	0.004% or –87 dB 20 Hz to 20 kHz
THD + n	±1.5 dB, 100 Hz to 20 kHz <sup>2</sup>	0.056% or –65 dB 20 Hz to 20 kHz
SINAD	±1.5 dB, 100 Hz to 20 kHz <sup>2</sup>	+65 dB 20 Hz to 20 kHz
AC Level V rms	±(0.13% of reading + 0.009% of range) 20 Hz to 20 kHz	

## DISTORTION MEASUREMENT AUDIO FILTERS

None C-Message  
 CCITT Weighting CCIR/ARM  
 CCIR "A" Weighting

**NUMBER OF HARMONICS INCLUDED IN THD CALCULATION:** 2 to 64 (user selectable).  
**HI AND LO CUTOFF FILTERS (bus settable):** 20Hz–50kHz. Can be combined to form brickwall bandpass filter.

## DISTORTION MEASUREMENT READING RATE<sup>3</sup>

Fundamental Frequency Acquisition Mode	Fundamental Frequency Range	Minimum Readings Per Second
Single acquisition or stored value	20 Hz to 100 Hz	14
	100 Hz to 1 kHz	24
	1 kHz to 20 kHz	28
Automatic	20 Hz to 30 Hz	5.5
	30 Hz to 400 Hz	6
	400 Hz to 20 kHz	6.6

## FREQUENCY SWEEP READING RATE

Number of Frequencies	Time (seconds) <sup>4</sup>
5	0.2
30	1.1
100	3.5
200	6.9

## NOTES

- Input signal at full scale.
- V<sub>IN</sub> ≥20% of range and harmonics > –65dB.
- Speeds are for default operating conditions (\*RST), and display off, auto range off, binary data transfer, trig delay = 0.
- Typical times: frequencies in 400–4kHz range, binary data transfer, TRIG DELAY = 0, Display OFF, Auto Range OFF. Data returned is THD measurement plus AC voltage.

## GENERATOR CHARACTERISTICS

**FREQUENCY RANGE:** 10–20kHz.  
**FREQUENCY RESOLUTION:** 0.007Hz.  
**FREQUENCY ACCURACY:** ±(0.015% of reading + 0.007Hz)<sup>1</sup>.  
**FREQUENCY TEMPERATURE COEFFICIENT:** <100ppm over operating temperature range.

## SOURCE OUTPUT:

**WAVEFORM:** Sinewave.  
**AMPLITUDE RANGE:** 2015, 2015-P: 2V rms (50Ω and 600Ω) or 4V rms (HI Z).  
 2016, 2016-P: 4.75V rms (50Ω and 600Ω) or 9.5V rms (HI Z).  
**AMPLITUDE RESOLUTION:** 2015, 2015-P: 0.5mV rms (50Ω and 600Ω) or 1mV rms (HI Z).  
 2016, 2016-P: 1.25mV rms (50Ω and 600Ω) or 2.5mV rms (HI Z).  
**AMPLITUDE ACCURACY:** 2015, 2015-P: ±(0.3% of setting + 2mV)<sup>1,4</sup>.  
 2016, 2016-P: ±(0.3% of setting + 5mV)<sup>1,4</sup>.  
**AMPLITUDE TEMPERATURE COEFFICIENT:** Typically 0.015%/°C.  
**AMPLITUDE FLATNESS:** ±0.1dB<sup>1,4,5</sup>.  
**OUTPUT IMPEDANCE:** 50Ω ± 1Ω or 600Ω ± 10Ω, user selectable.  
**THD:** –64dB<sup>6</sup>.  
**NOISE:** 2015, 2015-P: 100μV rms<sup>2</sup>.  
 2016, 2016-P: 250μV rms<sup>2</sup>.  
**DC OFFSET VOLTAGE:** 2015, 2015-P: ±1.2mV<sup>1</sup>. 2016, 2016-P: ±3mV<sup>1</sup>.

## INV/PULSE OUTPUT (SENAWAVE MODE):

**FREQUENCY:** Same as source output.  
**AMPLITUDE RANGE:** 2015, 2015-P: 2V rms (50Ω and 600Ω) or 4V rms (HI Z).  
 2016, 2016-P: 4.75V rms (50Ω and 600Ω) or 9.5V rms (HI Z).  
**AMPLITUDE RESOLUTION:** 2015, 2015-P: 0.5mV (50Ω and 600Ω) or 1mV rms (HI Z).  
 2016, 2016-P: 1.25mV rms (50Ω and 600Ω) or 2.5mV rms (HI Z).  
**AMPLITUDE ACCURACY:** 2015, 2015-P: ±(2.0% of setting + 2mV)<sup>1,4</sup>.  
 2016, 2016-P: ±(2.0% of setting + 5mV)<sup>1,4</sup>.  
**AMPLITUDE FLATNESS:** ±0.1dB<sup>1,4,5</sup>.  
**OUTPUT IMPEDANCE:** Same as Source Output setting.  
**THD:** –64dB<sup>6</sup>.  
**NOISE:** 2015, 2015-P: 100μV rms<sup>2</sup>.  
 2016, 2016-P: 250μV rms<sup>2</sup>.  
**DC OFFSET VOLTAGE:** 2015, 2015-P: ±1.1mV typ., ±13mV max.<sup>1</sup>  
 2016, 2016-P: ±3mV typ., ±13mV max.<sup>1</sup>

## INV/PULSE OUTPUT (PULSE MODE):

**FREQUENCY:** Same as source output.  
**DUTY CYCLE:** 45% ±3%.  
**OUTPUT IMPEDANCE:** Same output impedance as the source output.  
**AMPLITUDE:** 0.0V ±0.07V to 4.9V ±0.12V pulse open circuit<sup>1,3</sup>.  
 0.0V ±0.05V to 3.3V ±0.08V pulse 100Ω load<sup>1,3</sup>.  
**OVERSHOOT:** 1.0V maximum pulse open circuit<sup>3</sup>.  
 0.2V maximum with 100Ω load pulse open circuit<sup>3</sup>.  
**UNDERSHOOT:** 1.1V maximum pulse open circuit<sup>3</sup>.  
 0.45V maximum with 100Ω load pulse open circuit<sup>3</sup>.

## NOTES

- 1 year, 23°C ±5°C.
- Measured at V<sub>OUT</sub> = 0V with gain 100 amplifier and 2-pole 50kHz low pass filter, Inv/Pulse in sinewave mode, HI Z output impedance, and no load.
- With HI Z output impedance and 1m 50Ω coaxial cable.
- HI Z output impedance, no load.
- 4V output.
- THD measurement includes harmonics 2 through 5, 1V rms output, HI Z, no load.

1.888.KEITHLEY (U.S. only)

www.keithley.com

**KEITHLEY**

A Greater Measure of Confidence

A Tektronix Company

Model 2015, 2015-P, 2016, 2016-P specifications

DIGITAL MULTIMETERS & SYSTEMS



# 2015, 2015-P, 2016, 2016-P

# 6½-Digit THD Multimeters 6½-Digit Audio Analyzing Multimeters

## DC Characteristics

CONDITIONS: MED (1 PLC)<sup>3</sup> or SLOW (10 PLC) or MED (1 PLC) with filter of 10.

Function	Range	Resolution	Test Current or Burden Voltage (±5%)	Input Resistance	Accuracy: ±(ppm of reading + ppm of range) (ppm = parts per million) (e.g., 10ppm = 0.001%)			Temperature Coefficient 0°–18°C & 28°–50°C
					24 Hour <sup>14</sup> 23°C ± 1°	90 Day 23°C ± 5°	1 Year 23°C ± 5°	
Voltage	100.0000 mV	0.1 μV		> 10 GΩ	30 + 30	40 + 35	50 + 35	2 + 6
	1.000000 V	1.0 μV		> 10 GΩ	15 + 6	25 + 7	30 + 7	2 + 1
	10.00000 V	10 μV		> 10 GΩ	15 + 4	20 + 5	30 + 5	2 + 1
	100.0000 V	100 μV		10 MΩ ±1%	15 + 6	30 + 6	45 + 6	5 + 1
	1000.000 V <sup>9</sup>	1 mV		10 MΩ ±1%	20 + 6	35 + 6	45 + 6	5 + 1
Resistance <sup>15</sup>	100.0000 Ω	100 μΩ	1 mA		30 + 30	80 + 40	100 + 40	8 + 6
	1.000000 kΩ	1 mΩ	1 mA		20 + 6	80 + 10	100 + 10	8 + 1
	10.00000 kΩ	10 mΩ	100 μA		20 + 6	80 + 10	100 + 10	8 + 1
	100.0000 kΩ	100 mΩ	10 μA		20 + 6	80 + 10	100 + 10	8 + 1
	1.000000 MΩ <sup>16</sup>	1 Ω	10 μA		20 + 6	80 + 10	100 + 10	8 + 1
	10.00000 MΩ <sup>11, 16</sup>	10 Ω	700 nA // 10MΩ		300 + 6	450 + 10	600 + 10	95 + 1
	100.0000 MΩ <sup>11, 16</sup>	100 Ω	700 nA // 10MΩ		1600 + 30	2000 + 30	2200 + 30	900 + 1
Current	10.00000 mA	10 nA	< 0.15 V		60 + 30	300 + 80	500 + 80	50 + 5
	100.0000 mA	100 nA	< 0.03 V		100 + 300	300 + 800	500 + 800	50 + 50
	1.000000 A	1 μA	< 0.3 V		200 + 30	500 + 80	800 + 80	50 + 5
	3.00000 A	10 μA	< 1 V		1000 + 15	1200 + 40	1200 + 40	50 + 5
Continuity 2W	1 kΩ	100 mΩ	1 mA		40 + 100	100 + 100	120 + 100	8 + 1
Diode Test	3.00000 V	10 μV	1 mA		20 + 6	30 + 7	40 + 7	8 + 1
	10.00000 V	10 μV	100 μA		20 + 6	30 + 7	40 + 7	8 + 1
	10.00000 V	10 μV	10 μA		20 + 6	30 + 7	40 + 7	8 + 1

## DC OPERATING CHARACTERISTICS<sup>2</sup>

Function	Digits	Readings/s	PLCs <sup>8</sup>
	6½ <sup>3,4</sup>	5	10
	6½ <sup>3,7</sup>	30	1
DCV (all ranges),	6½ <sup>3,5</sup>	50	1
DCI (all ranges),	5½ <sup>3,5</sup>	270	0.1
2W Ohms (<10M ranges)	5½ <sup>5</sup>	500	0.1
	5½ <sup>5</sup>	1000	0.04
	4½ <sup>5</sup>	2000	0.01

## DC SYSTEM SPEEDS<sup>2, 6</sup>

RANGE CHANGE<sup>3</sup>: 50/s.

FUNCTION CHANGE<sup>3</sup>: 45/s.

AUTORANGE TIME<sup>3, 10</sup>: <30ms.

ASCII READINGS TO RS-232 (19.2K baud): 55/s.

MAX. INTERNAL TRIGGER RATE: 2000/s.

MAX. EXTERNAL TRIGGER RATE: 400/s.

## DC GENERAL

LINEARITY OF 10VDC RANGE: ±(1ppm of reading + 2ppm of range).

DCV, Ω, TEMPERATURE, CONTINUITY, DIODE TEST INPUT PROTECTION: 1000V, all ranges.

MAXIMUM 4WΩ LEAD RESISTANCE: 10% of range per lead for 100Ω and 1kΩ ranges; 1kΩ per lead for all other ranges.

DC CURRENT INPUT PROTECTION: 3A, 250V fuse.

SHUNT RESISTOR: 0.1Ω for 3A, 1A, and 100mA ranges. 10Ω for 10mA range.

CONTINUITY THRESHOLD: Adjustable 1Ω to 1000Ω.

AUTOZERO OFF ERROR: Add ±(2ppm of range error + 5μV) for <10 minutes and ±1°C change.

OVERRANGE: 120% of range except on 1000V, 3A, and Diode.

## SPEED AND NOISE REJECTION

Rate	Readings/s	Digits	RMS Noise 10V Range	NMRR <sup>12</sup>	CMRR <sup>13</sup>
10 PLC	5	6½	< 1.5 μV	60 dB	140 dB
1 PLC	50	6½	< 4 μV	60 dB	140 dB
0.1 PLC	500	5½	< 22 μV	—	80 dB
0.01 PLC	2000	4½	< 150 μV	—	80 dB

## DC NOTES

- Add the following to ppm of range accuracy specification based on range: 1V and 100V, 2ppm; 100mV, 15ppm; 100Ω, 15ppm; 1kΩ–1MΩ, 2ppm; 10mA and 1A, 10ppm; 100mA, 40ppm.
- Speeds are for 60Hz operation using factory default operating conditions (\*RST). Autorange off, Display off, Trigger delay = 0.
- Speeds include measurement and binary data transfer out the GPIB.
- Auto zero off.
- Sample count = 1024, auto zero off.
- Auto zero off, NPLC = 0.01.
- Ohms = 24 readings/second.
- 1 PLC = 16.67ms @ 60Hz, 20ms @ 50Hz/400Hz. The frequency is automatically determined at power up.
- For signal levels >500V, add 0.02ppm/V uncertainty for the portion exceeding 500V.
- Add 120ms for ohms.
- Must have 10% matching of lead resistance in Input HI and LO.
- For line frequency ±0.1%.
- For 1kΩ unbalance in LO lead.
- Relative to calibration accuracy.
- Specifications are for 4-wire ohms. For 2-wire ohms, add 1Ω additional uncertainty.
- For rear inputs. Add the following to Temperature Coefficient "ppm of reading" uncertainty: 10MΩ 70ppm, 100MΩ 385ppm. Operating environment specified for 0° to 50°C, 50% RH at 35°C.

1.888.KEITHLEY (U.S. only)

www.keithley.com

KEITHLEY

A Greater Measure of Confidence

A Tektronix Company

**2015, 2015-P,  
2016, 2016-P**

# 6½-Digit THD Multimeters 6½-Digit Audio Analyzing Multimeters

## True RMS AC Voltage and Current Characteristics

Voltage Range	Resolution	Calibration Cycle	Accuracy <sup>1</sup> : ±(% of reading + % of range), 23°C ±5 °C				
			3 Hz– 10 Hz <sup>10</sup>	10 Hz– 20 kHz	20 kHz– 50 kHz	50 kHz– 100 kHz	100 kHz– 300 kHz
100.0000 mV	0.1 μV	90 Days 1 Year					
1.000000 V	1.0 μV		0.35 + 0.03	0.05 + 0.03	0.11 + 0.05	0.60 + 0.08	4 + 0.5
10.00000 V	10 μV		0.35 + 0.03	0.06 + 0.03	0.12 + 0.05	0.60 + 0.08	4 + 0.5
100.0000 V	100 μV						
750.000 V	1 mV						
		<b>Temperature Coefficient/°C<sup>8</sup></b>	0.035 + 0.003	0.005 + 0.003	0.006 + 0.005	0.01 + 0.006	0.03 + 0.01

Current Range	Resolution	Calibration Cycle	3 Hz–10 Hz	10 Hz–3 kHz	3 kHz–5 kHz
1.000000 A	1 μA	90 Day/1 Year	0.30 + 0.04	0.10 + 0.04	0.14 + 0.04
3.00000 A <sup>9</sup>	10 μA	90 Day/1 Year	0.35 + 0.06	0.15 + 0.06	0.18 + 0.06
		<b>Temperature Coefficient/°C<sup>8</sup></b>	0.035 + 0.006	0.015 + 0.006	0.015 + 0.006

### HIGH CREST FACTOR ADDITIONAL ERROR ±(% of reading)<sup>7</sup>

CREST FACTOR:	1–2	2–3	3–4	4–5
ADDITIONAL ERROR:	0.05	0.15	0.30	0.40

### AC OPERATING CHARACTERISTICS<sup>2</sup>

Function	Digits	Readings/s	Rate	Bandwidth
ACV (all ranges), and ACI (all ranges)	6½ <sup>3</sup>	2s/reading	SLOW	3 Hz–300 kHz
	6½ <sup>3</sup>	1.4	MED	30 Hz–300 kHz
	6½ <sup>4</sup>	4.8	MED	30 Hz–300 kHz
	6½ <sup>3</sup>	2.2	FAST	300 Hz–300 kHz
	6½ <sup>4</sup>	35	FAST	300 Hz–300 kHz

### ADDITIONAL LOW FREQUENCY ERRORS ±(% of reading)

	Slow	Med	Fast
20 Hz – 30 Hz	0	0.3	—
30 Hz – 50 Hz	0	0	—
50 Hz – 100 Hz	0	0	1.0
100 Hz – 200 Hz	0	0	0.18
200 Hz – 300 Hz	0	0	0.10
> 300 Hz	0	0	0

### AC SYSTEM SPEEDS<sup>2, 5</sup>

FUNCTION/RANGE CHANGE<sup>6</sup>: 4/s.  
 AUTORANGE TIME: <3s.  
 ASCII READINGS TO RS-232 (19.2k baud)<sup>4</sup>: 50/s.  
 MAX. INTERNAL TRIGGER RATE<sup>4</sup>: 300/s.  
 MAX. EXTERNAL TRIGGER RATE<sup>4</sup>: 260/s.

### AC GENERAL

INPUT IMPEDANCE: 1MΩ ±2% paralleled by <100pF.  
 ACV INPUT PROTECTION: 1000Vp.  
 MAXIMUM DCV: 400V on any ACV range.  
 ACI INPUT PROTECTION: 3A, 250V fuse.  
 BURDEN VOLTAGE: 1A Range: <0.3V rms. 3A Range: <1V rms.  
 SHUNT RESISTOR: 0.1Ω on all ACI ranges.  
 AC CMRR: >70dB with 1kΩ in LO lead.  
 MAXIMUM CREST FACTOR: 5 at full scale.  
 VOLT HERTZ PRODUCT: ≤8 × 10<sup>6</sup>VHz.  
 OVERRANGE: 120% of range except on 750V and 3A ranges.

### AC NOTES

- Specifications are for SLOW rate and sine wave inputs >5% of range.
- Speeds are for 60Hz operation using factory default operating conditions (\*RST). Auto zero off, Auto range off, Display off, includes measurement and binary data transfer out the GPIB.
- 0.01% of step settling error. Trigger delay = 400ms.
- Trigger delay = 0.
- DETECTOR: BANDwidth 300, NPLC = 0.01.
- Maximum useful limit with trigger delay = 175ms.
- Applies to non-sine waves >5Hz and <500Hz. (Guaranteed by design for crest factors >4.3.)
- Applies to 0°–18°C and 28°–50°C.
- For signal levels >2.2A, add additional 0.4% to "of reading" uncertainty.
- Typical uncertainties. Typical represents two sigma or 95% of manufactured units measure <0.35% of reading and three sigma or 99.7% <1.06% of reading.

1.888.KEITHLEY (U.S. only)

www.keithley.com

KEITHLEY

A Greater Measure of Confidence

A Tektronix Company

Model 2015, 2015-P, 2016, 2016-P specifications

DIGITAL MULTIMETERS & SYSTEMS

# 2015, 2015-P, 2016, 2016-P

# 6½-Digit THD Multimeters 6½-Digit Audio Analyzing Multimeters

## Triggering and Memory

READING HOLD SENSITIVITY: 0.01%, 0.1%, 1%, or 10% of reading.  
 TRIGGER DELAY: 0 to 99 hrs (1ms step size).  
 EXTERNAL TRIGGER LATENCY: 200 $\mu$ s + <300 $\mu$ s jitter with autozero off, trigger delay = 0.  
 MEMORY: 1024 readings.

## Math Functions

Rel, Min/Max/Average/StdDev (of stored reading), dB, dBm, Limit Test, %, and mX+b with user defined units displayed.

**dBm REFERENCE RESISTANCES:** 1 to 9999 $\Omega$  in 1 $\Omega$  increments.

## Standard Programming Languages

SCPI (Standard Commands for Programmable Instruments).

## Frequency and Period Characteristics <sup>1, 2</sup>

ACV Range	Frequency Range	Period Range	Gate Time	Resolution $\pm$ (ppm of reading)	Accuracy 90 Day/1 Year $\pm$ (% of reading)
100 mV to 750 V	3 Hz to 500 kHz	333 ms to 2 $\mu$ s	1 s (SLOW)	0.333	0.01
			0.1 s (MED)	3.33	0.01
			10 ms (FAST)	33.3	0.01

### FREQUENCY NOTES

- Specifications are for square wave inputs only. Input signal must be >10% of ACV range. If input is <20mV on the 100mV range, then the frequency must be >10Hz.
- 20% overrange on all ranges except 750V range.

## Temperature Characteristics

### Thermocouple <sup>2, 3, 4</sup>

Type	Range	Resolution	Accuracy <sup>1</sup> 90 Day/1 Year (23°C $\pm$ 5°C) Relative to Reference Junction
J	-200 to + 760°C	0.001°C	$\pm$ 0.5°C
K	-200 to + 1372°C	0.001°C	$\pm$ 0.5°C
T	-200 to + 400°C	0.001°C	$\pm$ 0.5°C

### TEMPERATURE NOTES

- For temperatures <-100°C, add  $\pm$ 0.1°C and >900°C add  $\pm$ 0.3°C.
- Temperature can be displayed in °C, K, or °F.
- Accuracy based on ITS-90.
- Exclusive of thermocouple error.

## GENERAL

**POWER SUPPLY:** 100V/120V/220V/240V.

**LINE FREQUENCY:** 50Hz to 60Hz and 400Hz, automatically sensed at power-up.

**POWER CONSUMPTION:** 40VA.

**VOLT HERTZ PRODUCT:**  $\leq 8 \times 10^7$ VHz.

**SAFETY:** Conforms to European Union Low Voltage Directive.

**EMC:** Conforms to European Union EMC Directive.

**VIBRATION:** MIL-PRF-28800F Class 3 Random.

**OPERATING ENVIRONMENT:** Specified for 0°C to 50°C. Specified to 80% R.H. at 35°C and at an altitude of up to 2,000 meters.

**STORAGE ENVIRONMENT:** -40°C to 70°C.

**WARMUP:** 1 hour to rated accuracy.

### DIMENSIONS:

**Rack Mounting:** 89mm high  $\times$  213mm wide  $\times$  370mm deep (3.5 in  $\times$  8.38 in  $\times$  14.56 in).

**Bench Configuration (with handle and feet):** 104mm high  $\times$  238mm wide  $\times$  370mm deep (4.13 in  $\times$  9.38 in  $\times$  14.56 in).

**NET WEIGHT:** 4.2kg (8.8 lbs).

**SHIPPING WEIGHT:** 5kg (11 lbs).

1.888.KEITHLEY (U.S. only)

[www.keithley.com](http://www.keithley.com)

**KEITHLEY**

A Greater Measure of Confidence

A Tektronix Company

# Series 3700A

# System Switch/Multimeter and Plug-In Cards



- Combines the functions of a system switch and a high performance multimeter
- LXI compliance with IEEE-1588 time synchronization
- 3½- to 7½-digit measurement resolution
- Embedded Test Script Processor (TSP®) offers unparalleled system automation, throughput, and flexibility
- Extended low ohms (1Ω) range with 100nΩ resolution
- Extended low current (10μA) range with 1pA resolution
- >14,000 readings/second
- Low noise, <0.1ppm rms noise on 10VDC range
- Expanded dry circuit range (2kΩ)
- Four-wire open lead detection (source and sense lines)

For more information about Series 3700A systems, see page 162.

A Series 3700A system combines the functionality of an instrument grade relay switching system with a high performance multimeter. Integrating the multimeter within the mainframe ensures you of a high quality signal path from each channel to the multimeter. This tightly integrated switch and measurement system can meet the demanding application requirements of a functional test system or provide the flexibility needed in stand-alone data acquisition and measurement applications. It is ideal for multiple pin count applications where relay switching can be used to connect multiple devices to source and measurement instruments.

The high performance multimeter in the Series 3700A offers low noise, high stability 3½- to 7½-digit readings for leading-edge measurement performance. This flexible resolution supplies a DC reading rate from >14,000 readings/second at 3½ digits to 60 readings/second at 7½ digits, offering customers maximum reading throughput and accuracy. The multimeter also provides an expanded low ohms (1Ω) range, low current (10μA) range, and dry circuit (1Ω to 1kΩ) range, extending utility beyond typical DMM applications.

The multimeter supports 13 built-in measurement functions, including: DCV, ACV, DCI, ACI, frequency, period, two-wire ohms, four-wire ohms, three-wire RTD temperature, four-wire RTD temperature, thermocouple temperature, thermistor temperature, and continuity. In-rack calibration is supported, which reduces both maintenance and calibration time. Onboard memory can store up to 650,000 readings, and the USB device port provides easy transfer of data to memory sticks.

### Single Channel Reading Rates

Resolution	DCV/	
	2-Wire Ohms	4-Wire Ohms
7½ Digits (1 NPLC)	60	29
6½ Digits (0.2 NPLC)	295	120
5½ Digits (0.06 NPLC)	935	285
4½ Digits (0.006 NPLC)	6,300	580
3½ Digits (0.0005 NPLC)	14,000	650

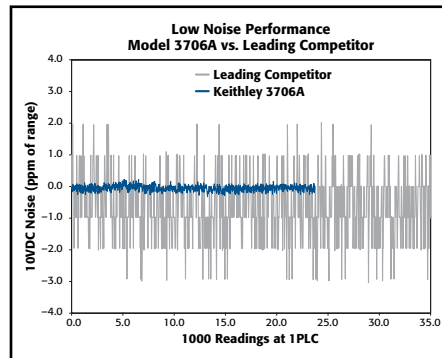

Compare the Model 3706A's 10V DC noise and speed performance with that of the leading competitor. All the data was taken at 1PLC with a low thermal short applied to the input, which resulted in 10× lower noise and 7× faster measurements for the Model 3706A.

### APPLICATIONS

- System- and rack-level signal referencing
- Power supply burn-in testing (PC, network, telecom)
- Low ohms testing (contacts, connectors, relays)
- Temperature profiling
- Plant/environment monitoring and control
- Automotive and aerospace systems
- Consumer product certification/testing laboratories

1.888.KEITHLEY (U.S. only)

[www.keithley.com](http://www.keithley.com)

A Greater Measure of Confidence

**KEITHLEY**

A Tektronix Company

System switch with high performance multimeter

DIGITAL MULTIMETERS & SYSTEMS

# 2700, 2701, 2750

## Multimeter/Data Acquisition/ Switch Systems



Integra Series systems (2700, 2701, 2750) combine precision measurement, switching, and control in a single, tightly integrated enclosure for either rack-mounted or benchtop applications. These cost-effective, high performance test platforms offer affordable alternatives to separate DMMs and switch systems, dataloggers/recorders, plug-in card data acquisition equipment, and VXI/PXI systems. The Integra Series plug-in switching and control modules offer unmatched flexibility and testing efficiency for a wide range of industries and applications. System builders can create test solutions with a combination of channel count, cost per channel, and system performance unmatched by any other single-box measurement system. The input modules provide the flexibility to vary the channel count from 20 to 200 (2-pole), apply a stimulus to the device under test, route signals, control system components, and make precision measurements with up to 14 functions. Robust digital I/O capabilities can be used for triggering, handshaking with other automation equipment, and alarm limit outputs. Scan rates of up to 500 channels/second (up to 3500 readings/second on a single channel) will increase test productivity.

### Fast Setup and Operation

The Integra systems are fully integrated, off-the-shelf measurement and control systems. Their DMM-like interfaces make it easy for users to collect data and/or perform troubleshooting within minutes of installation and startup. Once sensor or DUT leads are hooked to the instrument's input, use the front panel controls to select the measurement function, range, filtering, scaling, trigger source, scanning sequence, alarms, and more. The free ExcelINX-1A software makes it easy to configure and use the system in a graphical "point-and-click" environment. This gives developers the basic tools needed to create a simple application without writing program code.

### The Advantage of Integrated Design

The Integra systems offer a variety of advantages over existing solutions for ATE and data acquisition applications. For example, their flexible modular architecture and integrated measurement, switching, and control capabilities save rack space by reducing the number of separate instruments needed. This design also simplifies expanding the system as the number of channels grows or re-purposing it as new test requirements evolve. Integrated signal conditioning, scaling, stimulus, filtering and I/O capabilities eliminate the need for external circuitry when designing and building data acquisition systems. The Integra systems offer accuracy and repeatability superior to plug-in data acquisition boards, while providing faster test times than typical DMM/switch systems. This makes it possible to combine higher test yields with higher test throughput.

### Ethernet

The Model 2701 offers a 10/100 BaseT Ethernet connection for high speed and long distance communication between a computer and a virtually infinite number of instruments. Any PC with an Ethernet port can connect to a single Model

### Built-in measurement functions include:

- DCV • ACV • DCI • ACI
- Resistance (2- or 4-wire, offset compensation selectable)
- Dry circuit ohms (20mV clamp) 2750 only
- Temperature (with thermocouples, RTDs, or thermistors)
- Frequency/Period
- Continuity

- Combines functions of DMM, switch system, and datalogger
- True 6½-digit (22-bit) resolution
- Choice of 12 switch/control plug-in modules
- Up to 200 differential input channels (with 300V isolation) for measurement and control
- Convenient front panel inputs
- Free LabVIEW®, LabWindows/CVI, Visual Basic, and C/C++ drivers (IVI style)
- Ethernet, GPIB, RS-232 communications capabilities
- Free ExcelINX™-1A datalogging software

1.888.KEITHLEY (U.S. only)

[www.keithley.com](http://www.keithley.com)

**KEITHLEY**

A Greater Measure of Confidence

A Tektronix Company

# 2700, 2701, 2750

## Ordering Information

<b>2700</b>	<b>DMM, Data Acquisition, Datalogging System w/2 Slots</b>
<b>2701</b>	<b>DMM, Data Acquisition, Datalogging System w/2 Slots and Ethernet Support</b>
<b>2750</b>	<b>DMM, Data Acquisition, Switching, Datalogging System w/5 Slots</b>

## Accessories Supplied

**LabVIEW, LabWindows/ CVI, Visual Basic, and C/C++ drivers; manual; and Model 1751 Safety Test Leads.**

## ACCESSORIES AVAILABLE

2750-321A	Extra slot cover
7007-1	Shielded IEEE-488 Cable, 1m (3.3 ft.) (Models 2700, 2750 only)
7007-2	Shielded IEEE-488 Cable, 2m (6.6 ft.) (Models 2700, 2750 only)
7788	50-Pin D-Shell Connector Kit (2 each) (for Models 7703, 7705 Modules w/D-sub Connectors)
7789	50-Pin/25-Pin D-Shell Kit (1 each)
7790	50-Pin Male, 50-Pin Female, and 25-Pin Male IDC D-Shell Connector Kit (1 each) (Ribbon Cable not Included)
7797	Calibration Extender Board (for Model 2750)
7705-MTC-2	50-Pin Male to Female D-Sub Cable, 2m
7707-MTC-2	25-Pin Male to Female D-Sub Cable, 2m
KPCI-488LPA	IEEE-488 Interface/Controller for the PCI Bus (Models 2700, 2750 only)
KUSB-488B	IEEE-488 USB-to-GPIB Interface Adapter (Models 2700, 2750 only)

## SERVICES AVAILABLE

2700-3Y-EW	1-year factory warranty extended to 3 years from date of shipment
2701-3Y-EW	1-year factory warranty extended to 3 years from date of shipment
2750-3Y-EW	1-year factory warranty extended to 3 years from date of shipment
C/2700-3Y-ISO	3 (ISO-17025 accredited) calibrations within 3 years of purchase*
C/2701-3Y-ISO	3 (ISO-17025 accredited) calibrations within 3 years of purchase*
C/2750-3Y-ISO	3 (ISO-17025 accredited) calibrations within 3 years of purchase*

\*Not available in all countries

# Multimeter/Data Acquisition/ Switch Systems

2701 in a point-to-point configuration, to multiple Model 2701s through a hub, or to multiple Model 2701s distributed on a network.

The Model 2701 Ethernet port uses the industry-standard TCP/IP socket interface. This provides data rates up to 100Mbps/sec. and allows the instrument to be located up to 100 meters from the nearest computer or network hub in hardwired systems and miles in wireless Ethernet systems. The maximum distances between a control PC and the instruments are limited only by the size of the network. The instrument also provides a built-in diagnostic Web page for easy remote access to the Model 2701. Entering the instrument's IP address in the URL line of Microsoft Internet Explorer will allow communication with and control of the Model 2701. This Web page allows users to read and set network parameters, such as IP address, subnet mask, gateway, MAC address, and calibration dates, and to send commands to and query data from the Model 2701.

## Temperature Capabilities

Integra Series mainframes support three major types of temperature sensors with built-in signal conditioning and 300V isolation: thermocouples, RTDs, and thermistors. To begin using a sensor, simply hook it up and the instrument does the rest. If a thermocouple is broken or disconnected, the instrument will alert the operator. The mainframes also support three methods for cold-junction compensation (CJC): automatic (built-in), external (built-in), and simulated.



**Install up to five input modules in the 2750 mainframe (or up to two in the 2700 and 2701 mainframes). All switch/control modules are fully enclosed in impact-resistant plastic for exceptional ruggedness. Three connector alternatives simplify connecting the modules to DUTs. Rugged D-sub connectors allow quick, secure connections and are especially convenient when performing routine maintenance or when the system is installed in a rack. IDC ribbon cable adapters are supplied with the Model 7701, 7707, and 7709 modules for fast, uncomplicated hookups in production test and process monitoring applications. Oversize screw-terminal connectors simplify setup in applications that require the greatest connection flexibility. Additional D-sub and IDC ribbon cable connector kits and pre-wired cable assemblies are sold separately.**

## TYPICAL APPLICATIONS

- Production test of electronic products and devices
- Accelerated stress testing (AST)
- Process monitor and control
- Device characterization/R&D
- Low ohms, multichannel measurements

1.888.KEITHLEY (U.S. only)

[www.keithley.com](http://www.keithley.com)

A Greater Measure of Confidence

**KEITHLEY**

A Tektronix Company

# 2700, 2701, 2750

# Multimeter/Data Acquisition/ Switch Systems

## Web-Enabled Data Acquisition and Control via Standard Ethernet

A built-in 10/100BaseTX Ethernet interface makes the Model 2701 the best choice for distributed data acquisition applications that demand stable, high precision measurements. Just connect it directly to an Ethernet port—there's no need for additional interface cards, proprietary cables, or software. The Model 2701 is a cost-effective solution for industrial monitoring and control applications. It combines remote communications with high measurement precision for research and development tasks, such as remote equipment diagnostics and economical monitoring of lab environments.

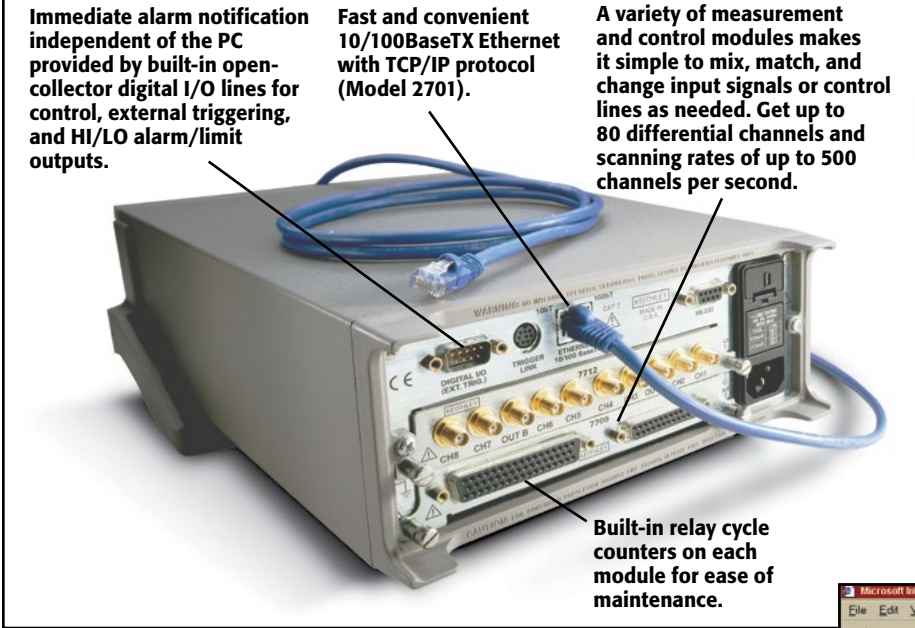

### Free built-In Web diagnostic tool (2701 only)

- Read and set network parameters
- Send command strings and receive data
- Debug

To start communicating with the Integra Series instrument, simply connect the 2701 to a PC Ethernet port using the supplied RJ-45 cross-over cable, start Microsoft® Internet Explorer version 5.0 or later, and type the instrument's IP address into the URL line. The built-in web diagnostic interface allows for easy communication and debugging, without the need to install external software. This interface makes it easy to read and set network parameters such as IP address, subnet mask, gateway, MAC address, calibration dates, and other data stored in the Integra Series instrument. It also takes readings from the instrument and allows the user to send command strings and receive data.

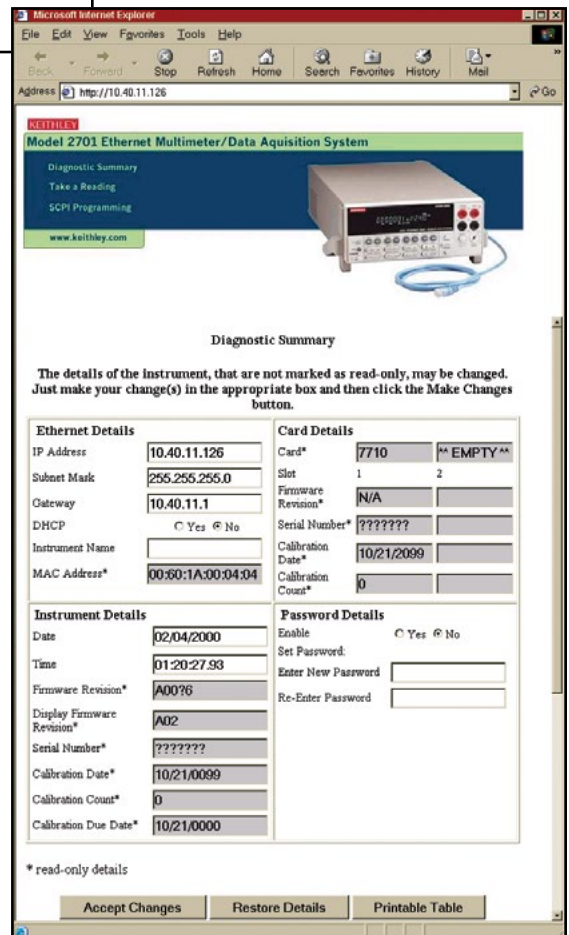

1.888.KEITHLEY (U.S. only)

[www.keithley.com](http://www.keithley.com)

**KEITHLEY**

A Greater Measure of Confidence

A Tektronix Company

# 2700, 2701, 2750

## Ordering Information

- 7700 20-channel Differential Multiplexer Module with up to 50MHz Bandwidth, Automatic CJC, and Screw Terminals
- 7701 32-channel Differential Multiplexer Module with a 25- and 50-Pin Female D-Sub Connector. Supplied with Male IDC Ribbon Cable Connectors
- 7702 40-channel Differential Multiplexer Module w/ Screw Terminals
- 7703 32-channel, High Speed, Differential Multiplexer Module with 2 50-Pin Female D-Sub Connectors. Includes 2 Mating Connectors
- 7705 40-channel, Single-pole Control Module with 2 50-Pin Female D-Sub Connectors. Includes 2 Mating Connectors
- 7706 All-in-One I/O Module: 20-channel Differential Multiplexer w/Automatic CJC, 16 Digital Outputs, 2 Analog Outputs, a Counter/Totalizer, and Screw Terminals
- 7707 32-channel Digital I/O w/10-channel Differential Multiplexer Module with a 25-Pin Female and 50-Pin Male D-Sub Connectors. Supplied with Mating IDC Ribbon Cable Connectors
- 7708 40-channel Differential Multiplexer Module w/Automatic CJC and Screw Terminals
- 7709 6x8 Matrix Module with 25- and 50-Pin Female D-Sub Connectors. Supplied with Male IDC Ribbon Cable Connectors
- 7710 20-channel Solid-state/ Long Life Differential Multiplexer w/Automatic CJC and Screw Terminals
- 7711 2GHz 50Ω RF Module with Dual 1x4 Configuration and SMA Connections
- 7712 3.5GHz 50Ω RF Module with Dual 1x4 Configuration and SMA Connections

# Multimeter/Data Acquisition/ Switch Systems

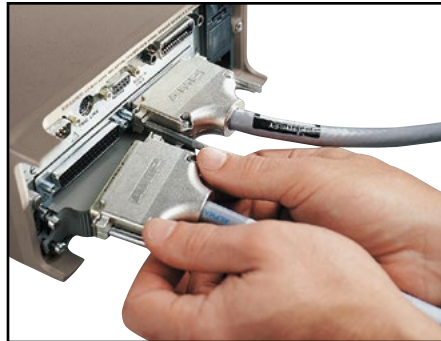

Rugged 50-pin D-sub connectors ensure dependability and quick setup/teardown in production test racks.

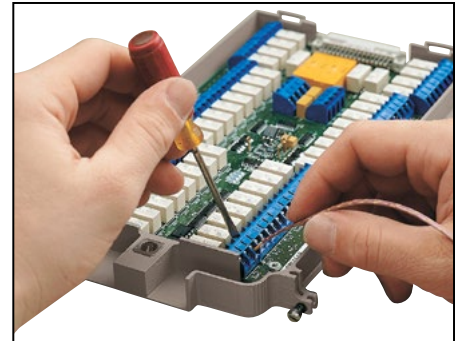

Screw terminals use oversized connectors for easier, mistake-free wiring. Easy-to-use removable terminals are available on some models.

## Software Solutions

Whether the task calls for a simple start-up package to acquire several channels of data or the tools to create a fully custom acquisition and analysis solution, Keithley has the software needed to get the most performance from a Model 2700, 2701, or 2750 Multimeter/Switch System. Our broad range of software solutions makes it easy to get applications "Up & Running" quickly and economically.

## Measurement Ranges for the Integra Series Systems

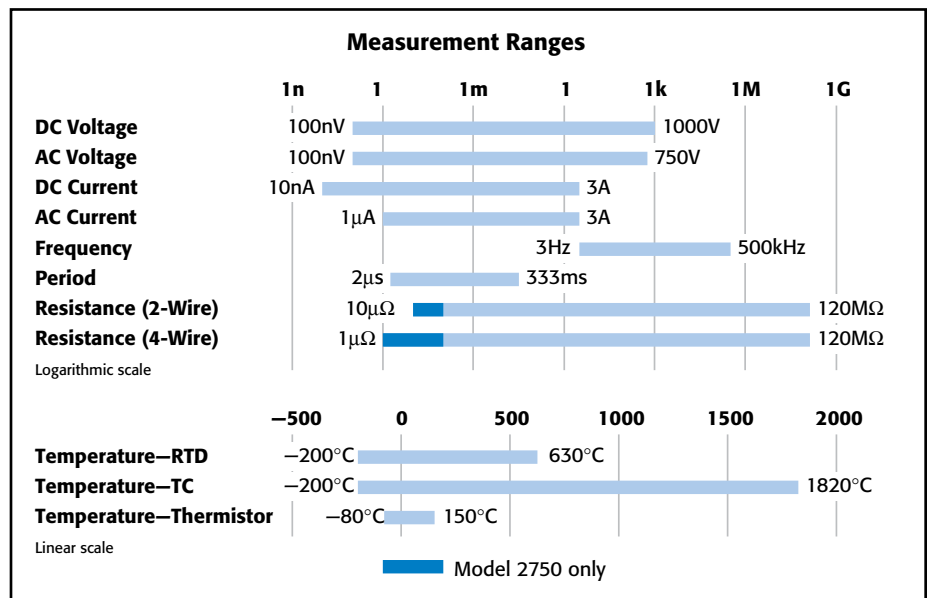

1.888.KEITHLEY (U.S. only)

www.keithley.com

A Greater Measure of Confidence

**KEITHLEY**

A Tektronix Company

Integra Series integrated switching, measurement, and datalogging solutions

DIGITAL MULTIMETERS & SYSTEMS



# 2700, 2701, 2750

# Multimeter/Data Acquisition/ Switch Systems

## Important Features and Benefits

- **Full per-channel configurability**—Each channel can be independently configured for making measurements. The parameters that can be chosen for each channel include speed, range, resolution, number of power line cycles (NPLC), filtering type, offset compensation, math functions to be displayed, CJC type, RTD type, frequency gate time, “m” and “b” values in  $mX + b$  format, HI/LO limits, low  $\Omega$  (Model 2750 only), ratio calculation, and thermistor type.
- **Channel monitor feature**—Monitor any specific input channel on the front panel display during a scan. This feature can also serve as an analog trigger to initiate a scan sequence based on some external factor, such as a temperature rising above a pre-set limit. Only the data of interest is acquired, so there’s no need to spend hours searching through reams of normal readings to find anomalous data.
- **Front/rear switch**—Switching between the front and rear panel measurement inputs is as easy as pressing a button. Users can select the front panel inputs for tasks such as system setup and verification, manual probing, troubleshooting, and calibration, while the rear panel inputs through the modules allow fast, automated multiplexing and control.
- **Battery-backed setup memory**—Up to four different setup configurations can be stored in onboard memory. If the line power fails during a scan, the system will resume scanning where it stopped once power is restored.
- **Relay counting**—Provides preventive maintenance of the system and switches.
- **Memory buffer**—The mainframe’s non-volatile wrap-around reading memory allows continuous, unattended datalogging over long periods. Data in the buffer can be transferred to a PC controller automatically as new data is acquired. The real-time clock can be used to time- and date-stamp readings for later review and interpretation.
- **2 TTL-level digital inputs**—Use to implement external triggers to initiate a scan sequence.
- **5 “per-channel” HI/LO alarm limit TTL outputs**—Trigger external alarms or perform other control functions without a PC controller.
- **Dry circuit ohms (20mV clamp)**—Protects sensitive devices from damage and prevents self-heating errors during testing (Model 2750 only).
- **Virtual channel**—Stores the results of channel-to channel ratio and average math operations.
- **Onboard statistical analysis**—Mathematical functions available at the push of a button are channel average,  $mX+b$  scaling, minimum, maximum, average, and standard deviation.
- **GPIB and RS-232 interfaces** (Models 2700 and 2750)
- **Ethernet and RS-232 interface** (Model 2701 only)

## Which Integra Mainframe is the Best Choice for the Application?

Use this selector guide to decide which Integra Series mainframe offers the combination of features and capacity that’s right for a specific application. If testing requirements change in the future, switch/control modules and test code can be easily re-used.

	2700	2701	2750
No. of differential input channels	80	80	200
Matrix crosspoints	96	96	240
Ohms resolution	100 $\mu\Omega$	100 $\mu\Omega$	1 $\mu\Omega$
Dry circuit ohms (20mV clamp)	No	No	Yes
No. of slots	2	2	5
Memory buffer	55,000 rdgs	450,000 rdgs	110,000 rdgs
Size (2U height)	Half-rack width	Half-rack width	Full-rack width (19")
Communications	GPIB, RS-232	Ethernet, RS-232	GPIB, RS-232
Scan-Rate (memory)	180/s	500/s	230/s
Scan-Rate (bus)	145/s	440/s	210/s
Max. Internal Trigger Rate	2000/s	2800/s	2000/s
Max. External Trigger Rate	375/s	2000/s	375/s

1.888.KEITHLEY (U.S. only)

[www.keithley.com](http://www.keithley.com)

**KEITHLEY**

A Greater Measure of Confidence

A Tektronix Company

# 2700, 2701, 2750

# Multimeter/Data Acquisition/ Switch Systems

## DC CHARACTERISTICS<sup>1</sup>

Conditions: MED (1 PLC)<sup>2</sup> or 10 PLC or MED (1 PLC) with Digital Filter of 10

Function	Range	Resolution	Test Current ±5% or Burden Voltage	Input Resistance or Open Circuit Voltage <sup>3</sup>		Accuracy: ±(ppm of reading + ppm of range) (ppm = parts per million) (e.g., 10ppm = 0.001%)			Temperature Coefficient 0°-18°C & 28°-50°C
				2700/2701	2750	24 Hour <sup>4</sup> 23°C ±1°	90 Day 23°C ±5°	1 Year 23°C ±5°	
Voltage <sup>11</sup>	100.0000 mV	0.1 μV		>10 GΩ	>10 GΩ	15 + 30	25 + 35	30 + 35	(1 + 5)/°C
	1.000000 V	1.0 μV		>10 GΩ	>10 GΩ	15 + 6	25 + 7	30 + 7	(1 + 1)/°C
	10.00000 V	10 μV		>10 GΩ	>10 GΩ	10 + 4	20 + 5	30 + 5	(1 + 1)/°C
	100.0000 V	100 μV		10 MΩ ±1%	10 MΩ ±1%	15 + 6	35 + 9	45 + 9	(5 + 1)/°C
	1000.000 V <sup>5</sup>	1 mV		10 MΩ ±1%	10 MΩ ±1%	20 + 6	35 + 9	50 + 9	(5 + 1)/°C
Resistance <sup>6, 8</sup>	1.000000Ω <sup>24</sup>	1 μΩ	10 mA		5.9 V	80 + 40	80 + 40	100 + 40	(8 + 1)/°C
	10.00000Ω <sup>24</sup>	10 μΩ	10 mA		5.9 V	20 + 20	80 + 20	100 + 20	(8 + 1)/°C
	100.0000 Ω	100 μΩ	1 mA	6.9 V	12.2 V	20 + 20	80 + 20	100 + 20	(8 + 1)/°C
	1.000000kΩ	1 mΩ	1 mA	6.9 V	12.2 V	20 + 6	80 + 6	100 + 6	(8 + 1)/°C
	10.00000kΩ	10 mΩ	100 μA	6.9 V	6.8 V	20 + 6	80 + 6	100 + 6	(8 + 1)/°C
	100.0000kΩ	100 mΩ	10 μA	12.8 V	12.8 V	20 + 6	80 + 10	100 + 10	(8 + 1)/°C
	1.000000MΩ <sup>23</sup>	1.0 Ω	10 μA	12.8 V	12.8 V	20 + 6	80 + 10	100 + 10	(8 + 1)/°C
	10.00000MΩ <sup>7, 23</sup>	10 Ω	0.7 μA//10 MΩ	7.0 V	7.0 V	150 + 6	200 + 10	400 + 10	(70 + 1)/°C
	100.0000MΩ <sup>7, 23</sup>	100 Ω	0.7 μA//10 MΩ	7.0 V	7.0 V	800 + 30	2000 + 30	2000 + 30	(385 + 1)/°C
	1.000000 Ω	1 μΩ	10 mA		20 mV	80 + 40	80 + 40	100 + 40	(8 + 1)/°C
Dry Circuit Resistance <sup>21, 24</sup>	10.00000 Ω	10 μΩ	1 mA		20 mV	25 + 40	80 + 40	100 + 40	(8 + 1)/°C
	100.0000 Ω	100 μΩ	100 μA		20 mV	25 + 40	90 + 40	140 + 40	(8 + 1)/°C
	1.000000kΩ	1 mΩ	10 μA		20 mV	25 + 90	180 + 90	400 + 90	(8 + 1)/°C
	10.00000kΩ	10 mΩ	1 mA	6.9 V	12.2 V	40 + 100	100 + 100	100 + 100	(8 + 1)/°C
Continuity (2W)	20.00000 mA	10 nA	< 0.2 V			60 + 30	300 + 80	500 + 80	(50 + 5)/°C
	100.0000 mA	100 nA	< 0.1 V			100 + 300	300 + 800	500 + 800	(50 + 50)/°C
	1.000000 A	1.0 μA	< 0.5 V <sup>9</sup>			200 + 30	500 + 80	800 + 80	(50 + 5)/°C
	3.000000 A	10 μA	< 1.5 V <sup>9</sup>			1000 + 15	1200 + 40	1200 + 40	(50 + 5)/°C
Channel (Ratio) <sup>10</sup>	Ratio Accuracy = Accuracy of selected Channel Range + Accuracy of Paired Channel Range								
Channel (Average) <sup>10</sup>	Average Accuracy = Accuracy of selected Channel Range + Accuracy of Paired Channel Range								

## TEMPERATURE<sup>19</sup>

(Displayed in °C, °F, or K. Exclusive of probe errors.)

Thermocouples (Accuracy based on ITS-90)

Type	Range	Resolution	90 Day/1 Year (23°C ± 5°C)		Using 77XX Module*	Temperature Coefficient 0°-18°C & 28°-50°C
			Relative to Simulated Reference Junction	Using 77XX Module*		
J	-200 to + 760°C	0.001°C	0.2°C	1.0°C	1.0°C	0.03°C/°C
K	-200 to +1372°C	0.001°C	0.2°C	1.0°C	1.0°C	0.03°C/°C
N	-200 to +1300°C	0.001°C	0.2°C	1.0°C	1.0°C	0.03°C/°C
T	-200 to + 400°C	0.001°C	0.2°C	1.0°C	1.0°C	0.03°C/°C
E	-200 to +1000°C	0.001°C	0.2°C	1.0°C	1.0°C	0.03°C/°C
R	0 to +1768°C	0.1 °C	0.6°C	1.8°C	1.8°C	0.03°C/°C
S	0 to +1768°C	0.1 °C	0.6°C	1.8°C	1.8°C	0.03°C/°C
B	+350 to +1820°C	0.1 °C	0.6°C	1.8°C	1.8°C	0.03°C/°C

\* Using 7710 Module: J: 2.5°C; K: 1°C. N, T, E Types: 1.5°C. R, S, B Types: 2.7°C.

### 4-Wire RTD:

(100Ω platinum [PT100], D100, F100, PT385, PT3916, or user type. Offset compensation On.)

Range	Resolution	Accuracy	Temperature Coefficient
-200° to +630°C	0.01°C	0.06°C	0.003°C/°C
<b>Thermistor: (2.2kΩ, 5kΩ, and 10kΩ)<sup>20</sup></b>			
-80° to +150°C	0.01°C	0.08°C	0.002°C/°C

## DC SYSTEM SPEEDS<sup>15,18</sup>

	2700/2750	2701
RANGE CHANGES (excludes 4WΩ) <sup>16</sup> :	50/s (42/s)	50/s (42/s)
FUNCTION CHANGES <sup>16</sup> :	50/s (42/s)	50/s (42/s)
AUTORANGE TIME <sup>16</sup> :	<30 ms	<30 ms
ASCII READINGS TO RS-232 (19.2k baud):	55/s	300/s
MAX. EXTERNAL TRIGGER RATE:	375/s	2000/s

## DC MEASUREMENT SPEEDS<sup>15</sup>

Single Channel, 60Hz (50Hz) Operation

Function	Digits	Readings/s	PLCs
DCV, DCI, Ω (<10M), Thermocouple, Thermistor	6.5 <sup>12,16</sup>	5 (4)	10
	6.5 <sup>16</sup>	35 (28)	1
	6.5 <sup>12,16</sup>	45 (36)	1
	5.5 <sup>12,16</sup>	150 (120)	0.1
	5.5 <sup>16,17</sup>	300 (240)	0.1
2700 and 2750 only	5.5 <sup>17</sup>	500 (400)	0.1
	4.5 <sup>17</sup>	2500 (2000)	0.01
2701 only	3.5	3500 (3500)	0.002
4WΩ (<10M)	6.5 <sup>16</sup>	1.4 (1.1)	10
	6.5 <sup>16</sup>	15 (12)	1
	5.5 <sup>17</sup>	33 (25)	0.1
4WΩ OComp, RTD <sup>22</sup>	6.5 <sup>16</sup>	0.9 (0.7)	10
	6.5 <sup>16</sup>	8 (6.4)	1
	5.5 <sup>16,17</sup>	18 (14.4)	0.1
Channel (Ratio), Channel (AVG)	6.5 <sup>16</sup>	2.5 (2)	10
	6.5 <sup>16</sup>	15 (12)	1
	5.5 <sup>17</sup>	25 (20)	0.1

### Multiple Channels, Into Memory<sup>18</sup>

	Channels/s		
	2700	2701	2750
7710 Scanning DCV	180/s	500/s	230/s
7710 Scanning DCV with Limits or Time Stamp On	170/s	500/s	230/s
7710 Scanning DCV alternating 2WΩ	45/s	115/s	60/s

### Multiple Channels, Into and Out of Memory to GPIB<sup>16, 18</sup> or Ethernet

	Channels/s		
	2700	2701	2750
7702 Scanning DCV	65/s	75/s	65/s
7700 and 7708 Scanning Temperature (T/C)	50/s	50/s	50/s
7710 Scanning DCV	145/s	440/s	210/s
7710 Scanning DCV with Limits or Time Stamp On	145/s	440/s	210/s
7710 Scanning DCV alternating 2WΩ	40/s	115/s	55/s

1.888.KEITHLEY (U.S. only)

www.keithley.com

A Greater Measure of Confidence

KEITHLEY

A Tektronix Company

Integra Series condensed specifications

DIGITAL MULTIMETERS & SYSTEMS

# 2700, 2701, 2750

# Multimeter/Data Acquisition/Switch Systems

## DC SPEED vs. NOISE REJECTION

Rate	Filter	Readings/s <sup>12</sup>	Digits	RMS Noise		NMRR	CMRR <sup>14</sup>
				2700,2750	2701		
10	50	0.1 (0.08)	6.5	<1.2 $\mu$ V	<2.5 $\mu$ V	110 dB <sup>13</sup>	140 dB
1	Off	15 (12)	6.5	<4 $\mu$ V	<6 $\mu$ V	90 dB <sup>13</sup>	140 dB
0.1	Off	500 (400)	5.5	<22 $\mu$ V	<40 $\mu$ V	—	80 dB
0.01	Off	2500 (2000)	4.5	<150 $\mu$ V	<300 $\mu$ V	—	80 dB
0.002	Off	3500 (2800)	3.5	—	<1 mV	—	60 dB

## DC MEASUREMENT CHARACTERISTICS

### DC VOLTS

A-D LINEARITY: 2.0 ppm of reading + 1.0 ppm of range.

#### INPUT IMPEDANCE:

100mV–10V Ranges: Selectable >10G $\Omega$  // with <400pF or 10M $\Omega$   $\pm$ 1%.

100V, 1000V Ranges: 10M $\Omega$   $\pm$ 1%.

Dry Circuit: 100k $\Omega$   $\pm$  1% // <1 $\mu$ F.

EARTH ISOLATION: 500V peak, >10G $\Omega$  and <300pF any terminal to chassis.

INPUT BIAS CURRENT: <75pA at 23°C.

COMMON MODE CURRENT: <500nA<sub>pp</sub> at 50Hz or 60Hz.

AUTOZERO ERROR: Add  $\pm$ (2ppm of range error + 5 $\mu$ V) for <10 minutes and  $\pm$ 1°C.

INPUT PROTECTION: 1000V, all ranges. 300V with plug in modules.

### RESISTANCE

MAXIMUM 4W $\Omega$  LEAD RESISTANCE: 80% of range per lead (Dry Ckt mode). 5 $\Omega$  per lead for 1 $\Omega$  range; 10% of range per lead for 10 $\Omega$ , 100 $\Omega$ , and 1k $\Omega$  ranges; 1k $\Omega$  per lead for all other ranges.

OFFSET COMPENSATION: Selectable on 4W $\Omega$ , 1 $\Omega$ , 10 $\Omega$ , 100 $\Omega$ , 1k $\Omega$ , and 10k $\Omega$  ranges.

CONTINUITY THRESHOLD: Adjustable 1 to 1000 $\Omega$ .

INPUT PROTECTION: 1000V, all Source Inputs, 350V Sense Inputs. 300V with plug-in modules.

### DC CURRENT

SHUNT RESISTORS: 100mA–3A, 0.1 $\Omega$ , 20mA, 5 $\Omega$ .

INPUT PROTECTION: 3A, 250V fuse.

### THERMOCOUPLES

CONVERSION: ITS-90.

REFERENCE JUNCTION: Internal, External, or Simulated (Fixed).

OPEN CIRCUIT CHECK: Selectable per channel. Open >11.4k $\Omega$   $\pm$ 200 $\Omega$ .

## AC SPECIFICATIONS<sup>1</sup>

Function	Range	Resolution	Calibration Cycle	Accuracy: $\pm$ (% of reading + % of range), 23°C $\pm$ 5°C				
				3 Hz–10 Hz	10 Hz–20 kHz	20 kHz–50 kHz	50 kHz–100 kHz	100 kHz–300 kHz
Voltage <sup>2</sup>	100.0000 mV	0.1 $\mu$ V	90 Days (all ranges)	0.35 + 0.03	0.05 + 0.03	0.11 + 0.05	0.6 + 0.08	4.0 + 0.5
	1.000000 V	1.0 $\mu$ V						
	10.00000 V	10 $\mu$ V	1 Year (all ranges)	0.35 + 0.03	0.06 + 0.03	0.12 + 0.05	0.6 + 0.08	4.0 + 0.5
	100.0000 V	100 $\mu$ V						
	750.000 V	1.0 $\mu$ V						
			(Temp. Coeff.) <sup>3</sup>	0.035 + 0.003	0.005 + 0.003	0.006 + 0.005	0.01 + 0.006	0.03 + 0.01
Current <sup>2</sup>	1.000000 A	1.0 $\mu$ A	90 Day/1 Year	0.30 + 0.04	0.10 + 0.04	0.14 + 0.04		
	3.00000 A <sup>14</sup>	10 $\mu$ A						
				(Temp. Coeff.) <sup>3</sup>	0.035 + 0.006	0.015 + 0.006		
Frequency <sup>4</sup> and Period				(3 Hz–500 kHz) (333 ms–2 $\mu$ s)				
	100 mV to 750 V	0.333 ppm	90 Day/1 Year	100 ppm + 0.333 ppm (SLOW, 1s gate)				
		3.33 ppm		100 ppm + 3.33 ppm (MED, 100ms gate)				
		33.3 ppm		100 ppm + 33.3 ppm (FAST, 10ms gate)				

### DC NOTES

- 20% overrange except on 1000V and 3A.
- Add the following to "ppm of range" uncertainty: 100mV 15ppm; 1V and 100V 2ppm; for Model 2750 1 $\Omega$  and Dry Circuit  $\Omega$  40ppm; 10 $\rightarrow$ 1M $\Omega$  2ppm, for Models 2700/2701 100 $\Omega$  30ppm, 20mA and 1A 10ppm, 100mA 40ppm.
- $\pm$ 2% (measured with 10M $\Omega$  input resistance DMM, >10G $\Omega$  DMM on 10M $\Omega$  and 100M $\Omega$  ranges). For Dry Circuit  $\Omega$ ,  $\pm$ 25% with Input HI connected to Sense HI; with Sense HI disconnected add 30mV.
- Relative to calibration accuracy.
- For signal levels >500V, add 0.02ppm/V uncertainty for portion exceeding 500V.
- Specifications are for 4-wire  $\Omega$ , 1 $\Omega$ , 10 $\Omega$ , and 100 $\Omega$  with offset compensation on. With 77XX plug-in modules, LSYNC on. With offset compensation on, OPEN CKT. VOLTAGE is 12.8V. For 2-wire  $\Omega$  add 1.5 $\Omega$  to "ppm of range" uncertainty. 1 $\Omega$  range is 4-wire only.
- Must have 10% matching of lead resistance in Input HI and LO.
- Add the following to "ppm of reading" uncertainty when using plug in modules:

	10 k $\Omega$	100 k $\Omega$	1 M $\Omega$	10 M $\Omega$	100 M $\Omega$
All Modules:				220 ppm	2200 ppm
7701, 7703, 7707, 7709 Modules:	10 ppm	100 ppm	1000 ppm	1%	10%
7706, 7708, 7710 Modules:	5 ppm	50 ppm	500 ppm	5000 ppm	5%
7710 Module 23°C $\pm$ 5°C:	11 ppm	110 ppm	1100 ppm	1.1%	11%

- Add 1.5V when used with plug in modules.
- For RATIO, DCV only. For AVERAGE, DCV, and Thermocouples only. Available with plug in modules only.
- Add 6 $\mu$ V to "of range" uncertainty when using Models 7701, 7703, and 7707, and 3 $\mu$ V for Models 7706 and 7709.
- Auto zero off.
- For LSYNC On, line frequency  $\pm$ 0.1%. For LSYNC Off, use 60dB for  $\geq$  1PLC.
- For 1k $\Omega$  unbalance in LO lead. AC CMRR is 70dB.
- Speeds are for 60Hz (50Hz) operation using factory defaults operating conditions (\*RST). Autorange off, Display off, Limits off, Trigger delay = 0.
- Speeds include measurements and binary data transfer out the GPIB or ASCII data transfer for Ethernet and RS-232 (reading element only).
- Sample count = 1000, auto zero off (into memory buffer).
- Auto zero off, NPLC = 0.01 (Models 2700 and 2750), NPLC = 0.002 (Model 2701).
- Additional Uncertainty:

#### Plug-In Modules

Type	Range	Front Terminals Simulated Ref. Junction				
		7709 Simulated Ref. Junction	7701, 7703, 7707 Simulated Ref. Junction	7700, 7708, 7710 Using CJC	7706 Using CJC	
J	-200 to 0°C	0.1	0.1	0.3	0.8	1.6
K	-200 to 0°C	0.2	0.2	0.4	0.8	1.6
N	-200 to 0°C	0.3	0.3	0.6	0.8	1.6
T	-200 to 0°C	0.2	0.1	0.4	0.8	1.6
E	-200 to 0°C	—	0.1	0.3	0.8	1.6
R	0 to +400°C	0.4	0.6	1.2	0.5	1.0
S	0 to +400°C	0.4	0.6	1.2	0.5	1.0
B	+350 to +1100°C	0.8	0.3	1.7	0.5	1.0

- For lead resistance >0 $\Omega$ , add the following uncertainty/ $\Omega$  for measurement temperatures of:

	70°–100°C	100°–150°C
2.2 k $\Omega$ (44004)	0.22°C	1.11°C
5.0 k $\Omega$ (44007)	0.10°C	0.46°C
10 k $\Omega$ (44006)	0.04°C	0.19°C

- For 4-wire  $\Omega$  only, offset compensation on, LSYNC on.
- For Dry Circuit 1k $\Omega$  range, 2 readings/s max.
- For 2750 Front Inputs, add the following to Temperature Coefficient "ppm of reading" uncertainty: 1M $\Omega$  25ppm, 10M $\Omega$  250ppm, 100M $\Omega$  2500ppm. Operating environment specified for 0°C to 50°C and 50% RH at 35°C.
- Model 2750 only.
- Front panel resolution is limited to 0.1 $\Omega$ .

1.888.KEITHLEY (U.S. only)

www.keithley.com

KEITHLEY

A Greater Measure of Confidence

A Tektronix Company

# 2700, 2701, 2750

# Multimeter/Data Acquisition/ Switch Systems

## ADDITIONAL UNCERTAINTY $\pm$ (% of reading)

Low Frequency Uncertainty	Med	Fast
20 Hz – 30 Hz	0.3	—
30 Hz – 50 Hz	0	—
50 Hz – 100 Hz	0	1.0
100 Hz – 200 Hz	0	0.18
200 Hz – 300 Hz	0	0.10
>300 Hz	0	0

CREST FACTOR: <sup>5</sup>	1–2	2–3	3–4	4–5
Additional Uncertainty:	0.05	0.15	0.30	0.40
Max. Fundamental Freq.:	50kHz	50kHz	3kHz	1kHz
Maximum Crest Factor: 5 at full-scale.				

## AC MEASUREMENT CHARACTERISTICS

### AC VOLTS

MEASUREMENT METHOD: AC-coupled, True RMS.

INPUT IMPEDANCE:  $1M\Omega \pm 2\%$  // by  $<100pF$ .

INPUT PROTECTION: 1000Vp or 400VDC. 300Vrms with plug in modules.

### AC CURRENT

MEASUREMENT METHOD: AC-coupled, True RMS.

SHUNT RESISTANCE: 0.1 $\Omega$ .

BURDEN VOLTAGE: 1A  $<0.5Vrms$ , 3A  $<1.5Vrms$ . Add 1.5Vrms when used with plug in modules.

INPUT PROTECTION: 3A, 250V fuse.

### FREQUENCY AND PERIOD

MEASUREMENT METHOD: Reciprocal counting technique.

GATE TIME: SLOW 1s, MED 100ms, and FAST 10ms.

### AC GENERAL

AC CMRR<sup>6</sup>: 70dB.

VOLT HERTZ PRODUCT:  $\leq 8 \times 10^7$ .

## AC MEASUREMENT SPEEDS 7, 13

### Single Channel, 60Hz (50Hz) Operation

Function	Digits	Readings/s	Rate	Bandwidth
ACV, ACI	6.5	2s/Reading	SLOW	3 Hz–300 kHz
	6.5	4.8 (4)	MED	30 Hz–300 kHz
	6.5 <sup>9</sup>	40 (32)	FAST	300 Hz–300 kHz
Frequency, Period	6.5	1 (1)	SLOW	3 Hz–300 kHz
	5.5	9 (9)	MED	30 Hz–300 kHz
	4.5	35 (35)	FAST	300 Hz–300 kHz
	4.5 <sup>10</sup>	65 (65)	FAST	300 Hz–300 kHz

### Multiple Channel

7710 SCANNING ACV<sup>10, 11</sup>: 500/s.

7710 SCANNING ACV WITH AUTO DELAY ON: 2s/reading.

## AC SYSTEM SPEEDS 7, 9, 11

	2700/2750	2701
AC System Speed:	(19.2K)	(115.2K)
Range Changes: <sup>12</sup>	4/s (3/s)	4/s (3/s)
Function Changes: <sup>12</sup>	4/s (3/s)	4/s (3/s)
Autorange Time:	< 3s	< 3s
ASCII Readings to RS-232 (19.2k baud):	50/s	300/s
Max. External Trigger Rate:	250/s	2000/s

## AC NOTES

- 20% overrange except on 750V and 3A.
- Specification are for SLOW mode and sine wave inputs  $>5\%$  of range. SLOW and MED are multi-sample A/D conversions. FAST is DETector: BANDwidth 300 with nPLC = 1.0.
- Applies to  $0^{\circ}$ – $18^{\circ}C$  and  $28^{\circ}$ – $50^{\circ}C$ .
- For square wave inputs  $>10\%$  of ACV range, except 100mV range. 100mV range frequency must be  $>10Hz$  if input is  $<20mV$ .
- Applies to non-sine waves  $>5Hz$ .
- For  $1k\Omega$  unbalance in LO lead.
- Speeds are for 60Hz (50Hz) operation using factory defaults operating conditions (\*RST). Autorange off, Display off, Limits off, Trigger delay=0.
- For ACV inputs at frequencies of 50 or 60Hz ( $\pm 10\%$ ), add the following to “% of Range” uncertainty: 100mV 0.25%, 1V 0.05%, 10V 0.15%, 100V 0.03%, 750V 0.015 (Model 2701 only).
- Auto Zero off.
- Sample count = 1024.
- DETector: BANDwidth 300 with nPLC = 0.006 (2701 only).
- Maximum useful limit with trigger delay = 175ms.
- Includes measurement and binary data transfer out GPIB or ASCII data transfer for Ethernet and RS-232 (Reading Element only).

## GENERAL

EXPANSION SLOTS: 2 (2700, 2701), 5 (2750).

POWER SUPPLY: 100V / 120V / 220V / 240V  $\pm 10\%$ .

LINE FREQUENCY: 45Hz to 66Hz and 360Hz to 440Hz, automatically sensed at power-up.

POWER CONSUMPTION: 28VA (2700), 80VA (2701, 2750).

OPERATING ENVIRONMENT: Specified for  $0^{\circ}C$  to  $50^{\circ}C$ . Specified to 80% RH at  $35^{\circ}C$ .

STORAGE ENVIRONMENT:  $-40^{\circ}C$  to  $70^{\circ}C$ .

BATTERY: Lithium battery-backed memory, 3 years @  $23^{\circ}C$  (Models 2700, 2750) Lithium Ion battery-backed memory, 30 days of buffer storage @  $23^{\circ}C$  and  $>4$  hours charge time. Battery lifetime:  $>3$  years @  $23^{\circ}C$ ,  $>1.5$  years @  $50^{\circ}C$  (Model 2701)

EMC: Conforms to European Union Directive 89/336/EEC EN61326-1.

SAFETY: Conforms to European Union Directive 73/23/EEC EN61010-1, CAT I.

VIBRATION: MIL-PRF-28800F Class 3, Random.

WARM-UP: 2 hours to rated accuracy.

### DIMENSIONS:

**Rack Mounting:** 89mm high  $\times$  213mm wide (2700, 2701) or 485mm wide (2750)  $\times$  370mm deep (3.5 in  $\times$  8.375 in or 19 in  $\times$  14.563 in).

**Bench Configuration (with handle and feet):** 104mm high  $\times$  238mm wide (2700, 2701) or 485mm wide (2750)  $\times$  370mm deep (4.125 in  $\times$  9.375 in (2700, 2701) or 19 in (2750)  $\times$  14.563 in).

SHIPPING WEIGHT: 6.5kg (14 lbs.) (2700, 2701) or 13kg (28 lbs.) (2750).

DIGITAL I/O: 2 inputs, 1 for triggering and 1 for hardware interlock.

5 outputs, 4 for Reading Limits and 1 for Master Limit. Outputs are TTL compatible or can sink 250mA, diode clamped to 40V.

### TRIGGERING AND MEMORY:

**Window Filter Sensitivity:** 0.01%, 0.1%, 1%, 10%, or Full-scale of range (none).

**Reading Hold Sensitivity:** 0.01%, 0.1%, 1%, or 10% of reading.

**Trigger Delay:** 0 to 99 hrs (1ms step size).

**External Trigger Delay:**  $<2ms$  (2700),  $<1ms$  (2701, 2750).

**External Trigger Jitter:**  $<1ms$  (2700),  $<500\mu s$  (2701),  $<500\mu s$  (2750).

**Memory Size:** 55,000 readings (2700), 450,000 readings (2701), 110,000 readings (2750).

MATH FUNCTIONS: Rel, Min/Max/Average/Std Dev/Peak-to-Peak (of stored reading), Limit Test, %, 1/x, and mX+b with user defined units displayed.

### REMOTE INTERFACE:

GPIB (IEEE-488.2) (2700, 2750), RS-232C (2700, 2701, and 2750).

Ethernet TCP/IP (10bT and 100bT) (2701)

SCPI (Standard Commands for Programmable Instruments)

LabVIEW Drivers

### FOR MODEL 2701:

**Ethernet:** RJ-45 connector, TCP/IP, 10bT and 100bTx autosensed.

**IP Configuration:** Static or DHCP.

**Password Protection:** 11 Characters.

**Software:** Windows 98, NT, 2000, ME, and XP compatible. Internet Explorer 5.0 or higher required. Web page server by 2701.

1.888.KEITHLEY (U.S. only)

www.keithley.com

KEITHLEY

A Greater Measure of Confidence

A Tektronix Company

# 2700, 2701, 2750

# Multimeter/Data Acquisition/ Switch Systems

## Switch/Control Module Capabilities

All plug-in modules are compatible with the two-slot Model 2700 and Model 2701 Multimeter/Data Acquisition Systems and the five-slot Model 2750 Multimeter/Switch System. When the application's needs change, simply change modules. Integra systems reconfigure themselves automatically.

## Module Capabilities Overview

	7700	7701	7702	7703	7705	7706	7707	7708	7709	7710	7711	7712
DC Volts	✓	✓	✓	✓		✓	✓	✓	✓	✓		
DC Current	✓		✓									
Temperature												
T/C w/Automatic CJC	✓					✓		✓		✓		
T/C w/External CJC	✓	✓	✓	✓		✓	✓	✓	✓	✓		
RTD	✓	✓	✓	✓		✓	✓	✓	✓	✓		
Thermistor	✓	✓	✓	✓		✓	✓	✓	✓	✓		
Resistance (2- or 4-wire)	✓	✓	✓	✓		✓	✓	✓	✓	✓		
Continuity	✓	✓	✓	✓		✓	✓	✓	✓	✓		
AC Volts	✓	✓	✓	✓		✓	✓	✓	✓	✓		
AC Current	✓		✓									
Frequency	✓	✓	✓	✓		✓	✓	✓	✓	✓		
Event Counter/Totalizer						✓						
Signal Routing/Control	✓	✓	✓	✓	✓	✓	✓	✓	✓	✓	✓	✓
Digital Input							✓					
Digital Output						✓	✓					
Analog Output						✓						
RF Switching											✓	✓

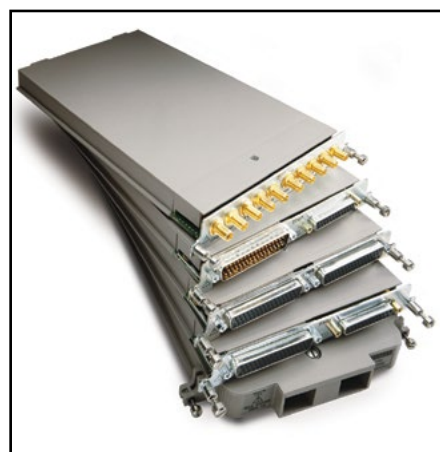

**Integra Plug-In Modules**

1.888.KEITHLEY (U.S. only)

[www.keithley.com](http://www.keithley.com)

A Greater Measure of Confidence

**KEITHLEY**  
A Tektronix Company

# Selector Guide

# Plug-In Modules for 2700, 2701, 2750 Integra Mainframes

## Module Selector Guide

This selector guide may prove helpful in identifying the best module for a specific application. Install up to five modules at a time in the Model 2750 mainframe or two modules in the Model 2700 or 2701 mainframe. Modules can be disconnected from internal DMM for routing external signals.

Module	# Analog Inputs	Configuration	Type of Connector	Max. Voltage	Max. Switched Current	Bandwidth	Contact Life <sup>1</sup>	Switch Speed	Other	
7700	20	Multiplexer w/CJC	1×20 or two 1×10	Screw terminals	300 V	1	50 MHz	10 <sup>8</sup>	3 ms	Maximum power = 125VA. 2 current measure channels.
7701	32	Multiplexer	1×32 or two 1×16	D-sub	150 V	1 A	2 MHz	10 <sup>8</sup>	3 ms	Maximum power = 125VA.
7702	40	Multiplexer	1×40 or two 1×20	Screw terminals	300 V	1 A	2 MHz	10 <sup>8</sup>	3 ms	Maximum power = 125VA. 2 current measure channels.
7703	32	Multiplexer	1×32 or two 1×16	D-sub	300 V	500 mA	2 MHz	10 <sup>8</sup>	1 ms	Reed relays.
7705	40	Independent SPST	N/A	D-sub	300 V	2 A	10 MHz	10 <sup>8</sup>	3 ms	Maximum power = 125VA.
7706	20	Multiplexer w/CJC	1×20 or two 1×10	Screw terminals	300 V	1 A	2 MHz	10 <sup>8</sup>	3 ms	2 analog outputs. 16 digital outputs. Maximum power = 125VA.
7707	10	Digital I/O/Multiplexer	1×10 or two 1×5	D-sub	300 V	1 A	2 MHz	10 <sup>8</sup>	3 ms	32 digital I/O. Maximum power = 125VA.
7708	40	Multiplexer w/CJC	1×40 or two 1×20	Screw terminals	300 V	1 A	2 MHz	10 <sup>8</sup>	3 ms	Maximum power = 125VA.
7709	48	Matrix	6×8	D-sub	300 V	1 A	2 MHz	10 <sup>8</sup>	3 ms	Connects to internal DMM. Daisy chain multiple cards for up to a 6×40 matrix. Maximum power = 125VA.
7710	20	Multiplexer w/CJC	1×20 or two 1×10	Removable screw terminals	60 V	0.1 A	2 MHz	10 <sup>10</sup>	0.5 ms	Solid state relays, 60V max. 500 channels/second scan rate.
7711	8	Multiplexer	Dual 1×4	SMA	60 V	0.5 A	2 GHz	10 <sup>6</sup>	10 ms	Insertion loss <1.0dB @ 1GHz. VSWR <1.2 @ 1GHz.
7712	8	Multiplexer	Dual 1×4	SMA	42 V	0.5 A	3.5 GHz	10 <sup>6</sup>	10 ms	Insertion loss <1.1dB @ 2.4GHz.

1. No load contact life. See card data sheet for additional specifications.

## Integra Plug-In Module Accessories

Module	Connector Type	Supplied Accessories	Available Accessories
7700	Oversized Screw Terminal	Strain Relief	7401 T/C wire
7701	50-pin female D-sub & 25-pin female D-sub	7789 connector kit	7790 connector kit, 7705-MTC-2 & 7707-MTC-2 cables
7702	Oversized Screw Terminal	Strain Relief	—
7703	Two 50-pin female D-sub	7788 connector kit	7705-MTC-2 cable
7705	Two 50-pin female D-sub	7788 connector kit	7705-MTC-2 cable
7706	Screw Terminal	Strain Relief	7401 T/C wire kit
7707	50-pin male D-sub & 25-pin female D-sub	7790 connector kit	7789 connector kit, 7705-MTC-2 & 7707-MTC-2 cables
7708	Oversized Screw Terminal	Strain Relief	7401 T/C wire kit
7709	50-pin female D-sub & 25-pin female D-sub	7790 connector kit	7789 connector kit, 7705-MTC-2 & 7707-MTC-2 cables
7710	Quick Disconnect Screw Terminal	Strain Relief	7401 T/C wire kit
7711	SMA	—	7711-BNC-SMA and 7712-SMA-N adapters, 7712-SMA-1 and S46-SMA-0.5, -1 SMA cables, 7051-2, -5, -10 BNC cables
7712	SMA	—	7712-SMA-N adaptor, 7712-SMA-1 & S46-SMA-0.5,-1 SMA cables

1.888.KEITHLEY (U.S. only)

[www.keithley.com](http://www.keithley.com)

A Greater Measure of Confidence

**KEITHLEY**

A Tektronix Company

Use with Integra Series mainframes: 2700, 2701, 2750

DIGITAL MULTIMETERS & SYSTEMS

# 7700

## 20-channel, Differential Multiplexer Module with Automatic CJC, Screw Terminals, and up to 50MHz Bandwidth

- 20 channels for general-purpose measurements, plus two channels to measure current
- Oversize screw terminal connection blocks are standard for easier connections
- 50MHz bandwidth
- 300V, 1A capacity for voltage channels; 60W, 125VA
- 3A capacity for current channels
- Low insertion loss of up to 50MHz
- Relay closures stored in onboard memory

### Ordering Information

**7700** 20-channel, Differential Multiplexer Module with Automatic CJC and Screw Terminals

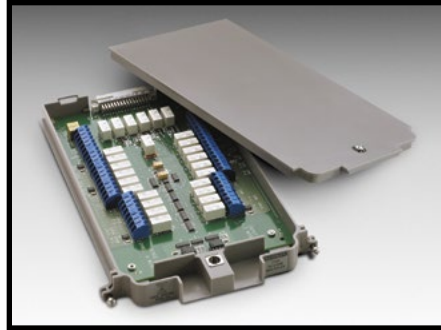

The Model 7700 plug-in module offers 20 channels of 2-pole or 10 channels of 4-pole multiplexer switching that can be configured as two independent banks of multiplexers. There are two additional protected channels for current measurements. Automatic CJC is provided so that no other accessories are required to make thermocouple temperature measurements. In addition, the Model 7700 contains latching electromechanical relays that enable signal bandwidths of up to 50MHz. The Model 7700 is ideal for RTD, thermistor, and thermocouple temperature applications.

### CAPABILITIES

**CHANNELS 1-20:** Multiplex one of 20 2-pole or one of 10 4-pole signals into DMM.

**CHANNELS 21-22:** Multiplex one of 2 2-pole current signals into DMM.

### INPUTS

#### MAXIMUM SIGNAL LEVEL:

**Channels (1-20):** 300V DC or 300V rms (425V peak) for AC waveforms, 1A switched, 60W, 125VA maximum.

**Channels (21-22):** 60V DC or 30V rms, 3A switched, 60W, 125VA maximum.

**CONTACT LIFE (typ.):**  $>10^5$  operations at max. signal level.  
 $>10^8$  operations no load<sup>1</sup>.

<sup>1</sup> Open thermocouple detector on during thermocouple measurements. Minimum signal level 10mV, 10 $\mu$ A.

**CONTACT RESISTANCE:**  $<1\Omega$  at end of contact life.

**CONTACT POTENTIAL:**  $<\pm 500$ nV typical per contact, 1 $\mu$ V max.  
 $<\pm 500$ nV typical per contact pair, 1 $\mu$ V max.

**OFFSET CURRENT:**  $<100$ pA.

**CONNECTOR TYPE:** Screw terminal, #20 AWG wire size.

**ISOLATION BETWEEN ANY TWO TERMINALS:**  $>10^{10}\Omega$ ,  $<100$ pF.

**ISOLATION BETWEEN ANY TERMINAL AND EARTH:**  $>10^{10}\Omega$ ,  $<200$ pF.

#### INSERTION LOSS (50 $\Omega$ Source, 50 $\Omega$ Load):

	w/Internal DMM	w/o Internal DMM*
$<0.1$ dB:	1 MHz	1 MHz
$<3$ dB:	2 MHz	50 MHz

#### CROSSTALK (50 $\Omega$ Load):

	w/Internal DMM	w/o Internal DMM*
10 MHz:	$<-40$ dB	$<-40$ dB
25 MHz:	**	$<-25$ dB

**COMMON MODE VOLTAGE:** 300V or 300V rms (425V peak) for AC waveforms between any terminal and chassis.

#### TEMPERATURE ACCURACY USING INTERNAL CJC:

1.0°C (see mainframe specification for details).

\* Channels 24 and 25 are open. Refer to ROUTe:MUlTiple command in 27XX User Manual.

\*\* Not valid.

### GENERAL

**20 CHANNELS:** 20 channels of 2-pole relay input. All channels configurable to 4-pole.

**2 CHANNELS:** 2 channels of current only input.

**RELAY TYPE:** Latching electromechanical.

**ACTUATION TIME:**  $<3$ ms.

**FIRMWARE:** Specified for Model 2700 rev. A01, 2701 rev. A01, and 2750 rev. A01 or higher.

### ENVIRONMENTAL

**OPERATING ENVIRONMENT:** Specified for 0°C to 50°C.  
Specified to 80% R.H. at 35°C.

**STORAGE ENVIRONMENT:** -25°C to 65°C.

**WEIGHT:** 0.45kg (1 lb).

**ACCESSORY AVAILABLE:** Model 7401 Type K Thermocouple Wire, 30.5m (100 ft).

### SERVICES AVAILABLE

7700-3Y-EW 1-year factory warranty extended to 3 years from date of shipment

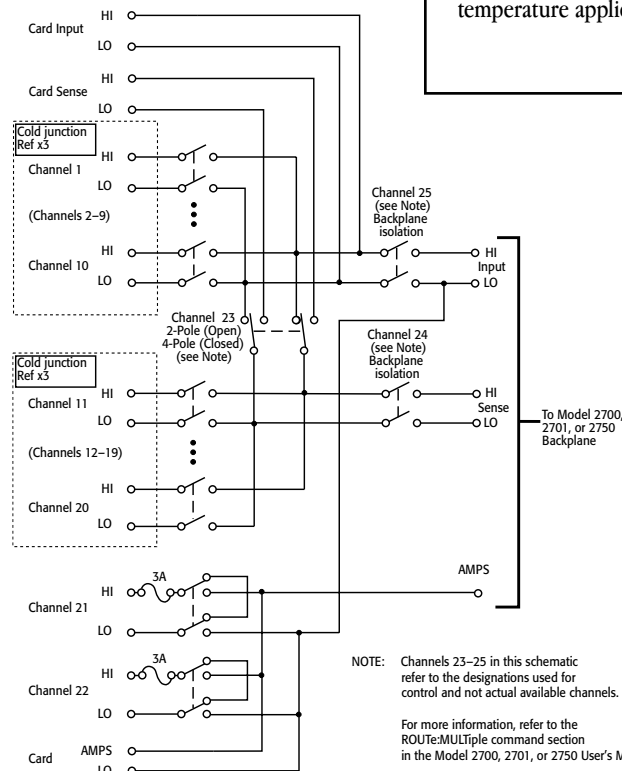

1.888.KEITHLEY (U.S. only)

www.keithley.com

KEITHLEY

A Greater Measure of Confidence

A Tektronix Company

# 7701

## 32-channel Differential Multiplexer Module

- Configurable for 32 channels of differential measurements, with up to 16 channels of 4-pole measurements
- Two female D-shell connectors are standard for secure hook-up and quick teardown
- 150V, 1A capacity for voltage channels; 60W, 125VA
- Relay closures stored in onboard memory
- Screw terminal jumpers allow user-configurable DMM connections

### Ordering Information

**7701** 32-channel, Differential Multiplexer Module

### Accessories Supplied

Two mating IDC connectors for ribbon cable



The Model 7701 plug-in module offers 32 channels of 2-pole or 16 channels of 4-pole multiplexer switching. Its 32 channels can be configured for common-side 4-wire ohms. They can also be configured as two independent banks of multiplexers. It is ideal for RTD or thermistor temperature applications.

### CAPABILITIES

**CHANNELS 1–32:** Multiplex one of 32 2-pole or one of 16 4-pole signals into DMM. Configuration supports dual 1×16 independent multiplexers.

### INPUTS

**MAXIMUM SIGNAL LEVEL: Any channel to Any Channel (1–32):** 150V DC or 150Vrms (212V peak) for AC waveforms, 1A switched, 60W, 125VA maximum.

**SAFETY:** Conforms to European Union Directive 73/23/EEC EN61010-1, CAT I.

**CONTACT LIFE (typ):** >10<sup>5</sup> operations at max. signal level. >10<sup>8</sup> operations no load<sup>1</sup>.

<sup>1</sup>Minimum signal level 10mV, 10μA.

**CONTACT RESISTANCE:** <1Ω any path and additional 1Ω at end of contact life.

**CONTACT POTENTIAL:** <6μV per contact pair.

**OFFSET CURRENT:** <100pA.

**CONNECTOR TYPE:** 50-pin female D-shell, Channels 1–24. 25-pin female D-shell, Channels 25–32.

Supplied with male IDC ribbon cable connectors.

**ISOLATION BETWEEN ANY TWO TERMINALS:** >10<sup>9</sup>Ω, <200pF.

**ISOLATION BETWEEN ANY TERMINAL AND EARTH:** >10<sup>9</sup>Ω, <400pF.

**CROSS TALK (1MHz, 50Ω Load):** <–35dB.

**INSERTION LOSS (50Ω Source, 50Ω Load):** <0.35dB below 1MHz. <3dB below 2MHz.

**COMMON MODE VOLTAGE:** 300VDC or 300Vrms (425V peak) for AC waveforms between any terminal and chassis.

### GENERAL

**32 CHANNELS:** 32 channels of 2-pole relay input. All channels configurable to 4-pole.

**RELAY TYPE:** Latching electromechanical.

**ACTUATION TIME:** <3ms.

**FIRMWARE:** Specified for Model 2700 rev. B03, Model 2701 rev. A01, and Model 2750 rev. A01 or higher.

**DMM CONNECTIONS:** Screw terminals provide internal DMM connections to channels 34 and 35 and connections to external wiring access.

### ENVIRONMENTAL

**OPERATING ENVIRONMENT:** Specified for 0°C to 50°C. Specified to 50% R.H. at 35°C.

**STORAGE ENVIRONMENT:** –25°C to 65°C.

**WEIGHT:** <0.52kg (1.16 lb).

### ACCESSORIES AVAILABLE

7789	50/25 Pin Male D-Shell Solder Cup Connectors
7790	50/50/25 Pin Female/Male D-Shell IDC Connectors
7705-MTC-2	50 Pin Male to Female D-sub Cable, 2m (6.6 ft).
7707-MTC-2	25 Pin Male to Female D-sub Cable, 2m (6.6 ft).

### SERVICES AVAILABLE

7701-3Y-EW	1-year factory warranty extended to 3 years from date of shipment
------------	---

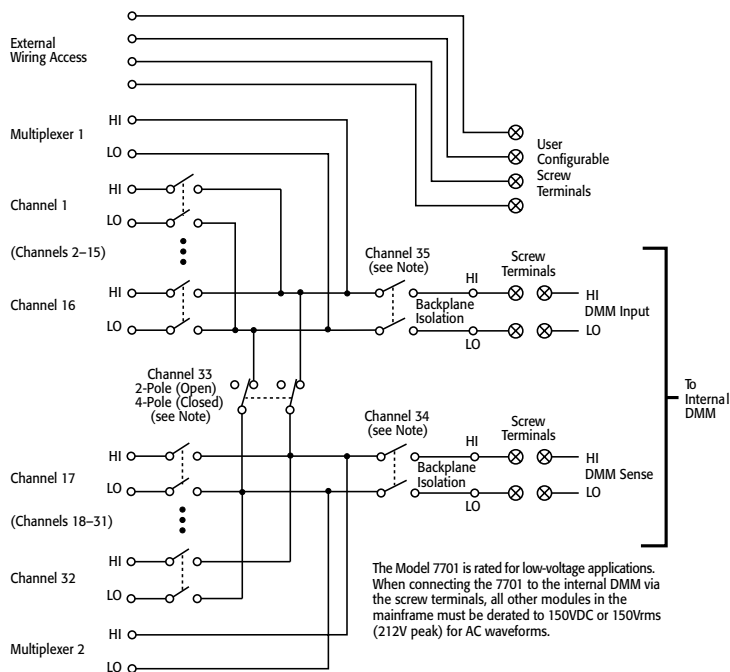

NOTE: Channels 33–35 in this schematic refer to the designations used for control and not actual available channels.

For more information, refer to the ROUTE:MULT command section in the Model 2700, 2701, or 2750 User's Manual.

1.888.KEITHLEY (U.S. only)

www.keithley.com

A Greater Measure of Confidence

**KEITHLEY**

A Tektronix Company

Use with Integra Series mainframes: 2700, 2701, 2750

DIGITAL MULTIMETERS & SYSTEMS



# 7702

## 40-channel Differential Multiplexer Module with Screw Terminals

- 40 channels for general-purpose measurements, plus 2 channels to measure current
- Two- or four-wire measurement
- Oversize screw terminal connection blocks are standard for easier connection
- 300V, 1A capacity for voltage channels; 60W, 125VA
- 3A capacity for current channels
- Relay closures stored in onboard memory

### Ordering Information

**7702 40-channel Differential Multiplexer Module with Screw Terminals**

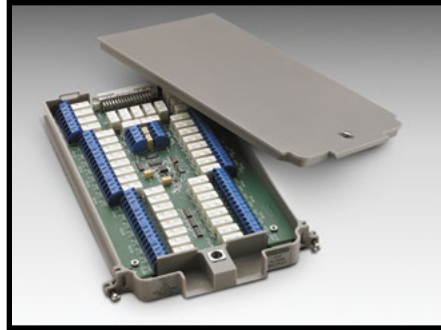

The Model 7702 plug-in module offers 40 channels of 2-pole or 20 channels of 4-pole multiplexer switching that can be configured as two independent banks of multiplexers. The Model 7702 provides two additional protected channels for current measurements. It is ideal for RTD, thermistor, and thermocouple temperature applications.

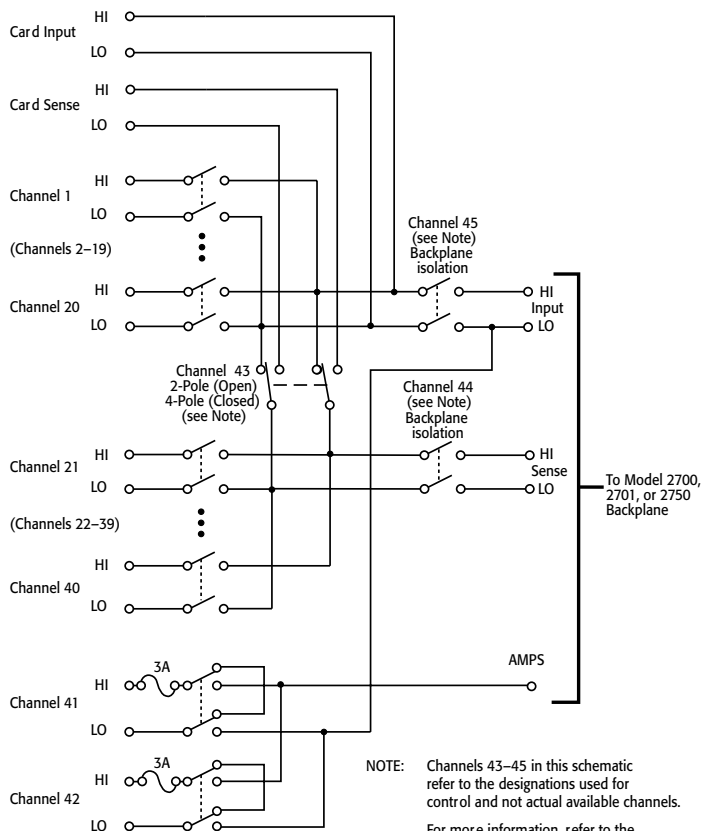

**NOTE:** Channels 43–45 in this schematic refer to the designations used for control and not actual available channels. For more information, refer to the ROUTe:Multiple command section in the Model 2700, 2701, or 2750 User's Manual. Channels 44 and 45 can be individually controlled using ROUTe:Multiple if the module is not to be connected to the internal DMM.

### CAPABILITIES

**CHANNELS 1-40:** Multiplex one of 40 2-pole or one of 20 4-pole signals into DMM.

**CHANNELS 41-42:** Multiplex one of 2 2-pole current signals into DMM.

### INPUTS

#### MAXIMUM SIGNAL LEVEL:

**Channels (1-40):** 300V DC or rms, 1A switched, 60W, 125VA maximum.

**Channels (41-42):** 60V DC or 30V rms, 3A switched, 60W, 125VA maximum.

**CONTACT LIFE (typ):** >10<sup>8</sup> operations at max. signal level. >10<sup>8</sup> operations no load<sup>1</sup>.

<sup>1</sup> Minimum signal level 10mV, 10μA.

**CONTACT RESISTANCE:** <1Ω at end of contact life.

#### CONTACT POTENTIAL:

<±500nV typical per contact, 1μV max.

<±500nV typical per contact pair, 1μV max.

**OFFSET CURRENT:** <100pA.

**CONNECTOR TYPE:** Screw terminal, #20 AWG wire size.

**ISOLATION BETWEEN ANY TWO TERMINALS:** >10<sup>10</sup>Ω, <100pF.

**ISOLATION BETWEEN ANY TERMINAL AND EARTH:** >10<sup>10</sup>Ω, <200pF.

**CROSS TALK (10MHz, 50Ω Load):** <-40dB.

**INSERTION LOSS (50Ω Source, 50Ω Load):** <0.1dB below 1MHz. <3dB below 2MHz.

**COMMON MODE VOLTAGE:** 300V between any terminal and chassis.

### GENERAL

**40 CHANNELS:** 40 channels of 2-pole relay input. All channels configurable to 4-pole.

**2 CHANNELS:** 2 channels of current only input.

**RELAY TYPE:** Latching electromechanical.

**ACTUATION TIME:** <3ms.

**FIRMWARE:** Specified for Model 2700 rev. A01, 2701 rev. A01, and 2750 rev. A01 or higher.

### ENVIRONMENTAL

**OPERATING ENVIRONMENT:** Specified for 0°C to 50°C. Specified to 80% R.H. at 35°C.

**STORAGE ENVIRONMENT:** -25°C to 65°C.

**WEIGHT:** 0.5kg (1.1 lb).

### SERVICES AVAILABLE

7702-3Y-EW 1-year factory warranty extended to 3 years from date of shipment

1.888.KEITHLEY (U.S. only)

[www.keithley.com](http://www.keithley.com)

**KEITHLEY**

A Tektronix Company

A Greater Measure of Confidence

# 7703

- 32 channels for general purpose measurements
- Relay actuation time of less than 1ms for high-speed scanning
- Two- or four-wire measurement
- Two 50-pin female D-sub connectors are standard for secure hook-up and quick teardown

## Ordering Information

**7703** 32-channel, High Speed, Differential Multiplexer Module

### Accessories Supplied

Two mating connectors with solder cup (Model 7788)

# 32-channel, High Speed, Differential Multiplexer Module



The Model 7703 plug-in module offers 32 channels of 2-pole or 16 channels of 4-pole multiplexer switching that can be configured as two independent banks of multiplexers. The non-latching reed relays provide high speeds and are designed for 300 volt, 500mA; 10VA. The relay closures are stored in onboard memory. The Model 7703 is ideal for RTD and thermistor temperature applications.

## CAPABILITIES

**CHANNELS 1–32:** Multiplex one of 32 2-pole or one of 16 4-pole signals into DMM.

## INPUTS

### MAXIMUM SIGNAL LEVEL:

**Channels (1–32):** 300V DC or rms, 0.5A switched, 10W maximum.

**Contact Life (typ):**  $>5 \times 10^4$  operations at max. signal level.  
 $>10^8$  operations cold switching.

**CONTACT RESISTANCE:**  $<1\Omega$  at end of contact life.

### CONTACT POTENTIAL:

$<\pm 3\mu\text{V}$  typical per contact,  $6\mu\text{V}$  max.  
 $<\pm 3\mu\text{V}$  typical per contact pair,  $6\mu\text{V}$  max.

**OFFSET CURRENT:**  $<100\text{pA}$ .

**CONNECTOR TYPE:** 50 pin D-sub  $\times 2$ .

**RELAY DRIVE CURRENT:** 20mA per channel.

**ISOLATION BETWEEN ANY TWO TERMINALS:**  $>10^9\Omega$ ,  $<200\text{pF}$ .

**ISOLATION BETWEEN ANY TERMINAL AND EARTH:**  $>10^9\Omega$ ,  $<400\text{pF}$ .

**CROSS TALK (1 MHz, 50 $\Omega$  Load):**  $<-40\text{dB}$ .

**INSERTION LOSS (50 $\Omega$  Source, 50 $\Omega$  Load):**  $<0.35\text{dB}$  below 1MHz.  $<3\text{dB}$  below 2MHz.

**COMMON MODE VOLTAGE:** 300V between any terminal and chassis.

## GENERAL

**32 CHANNELS:** 32 channels of 2-pole relay input.  
All channels configurable to 4-pole.

**RELAY TYPE:** Reed.

**ACTUATION TIME:**  $<1\text{ms}$ .

**FIRMWARE:** Specified for Model 2700 rev. A01, 2701 rev. A01, and 2750 rev. A01 or higher.

## ENVIRONMENTAL

**OPERATING ENVIRONMENT:** Specified for  $0^\circ\text{C}$  to  $50^\circ\text{C}$ .  
Specified to 80% R.H. at  $35^\circ\text{C}$ .

**STORAGE ENVIRONMENT:**  $-25^\circ\text{C}$  to  $65^\circ\text{C}$ .

**WEIGHT:** 0.8kg (1.75 lbs).

## ACCESSORIES AVAILABLE

7705-MTC-2 50 Pin Male to Female D-sub Cable, 2m (6.6 ft).

## SERVICES AVAILABLE

7703-3Y-EW 1-year factory warranty extended to 3 years from date of shipment

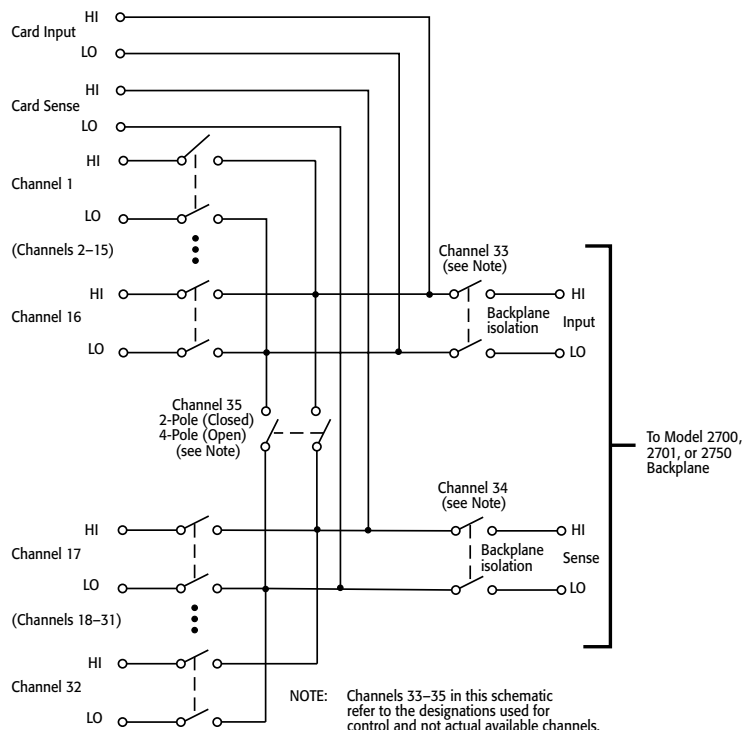

1.888.KEITHLEY (U.S. only)

www.keithley.com

A Greater Measure of Confidence

**KEITHLEY**  
A Tektronix Company

Use with Integra Series mainframes: 2700, 2701, 2750

DIGITAL MULTIMETERS & SYSTEMS

# 7705

- 300V, 2A capacity
- Two 50-pin female D-sub connectors are standard for secure hook-up and quick teardown
- Relay closures stored in onboard memory

## Ordering Information

**7705** 40-channel, Single-pole Control Module

### Accessories Supplied

Two mating connectors with solder cup (Model 7788)

# 40-channel, Single-pole Control Module



The Model 7705 plug-in module offers 40 channels of independent switching. These channels are designed to control power to the DUT and switching loads. They can also directly control light indicators, relays, etc.

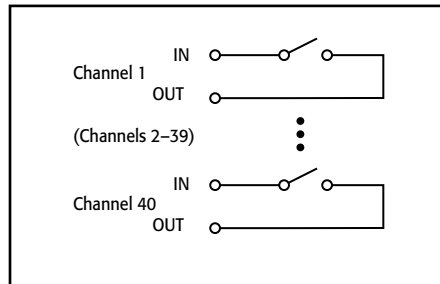

## INPUTS

**MAXIMUM SIGNAL LEVEL:** 300VDC or rms, 2A switched, 60W (DC, resistive), 125VA (AC, resistive).

**CONTACT LIFE: No Load<sup>1</sup>:** 10<sup>8</sup> closures.

**At Maximum Signal Levels:** 10<sup>5</sup> closures.

<sup>1</sup> Minimum signal level 10mV, 10μA.

**CHANNEL RESISTANCE (per conductor):** <1Ω.

**CONTACT POTENTIAL:** ≤4μV per contact.

**OFFSET CURRENT:** <100pA.

**ACTUATION TIME:** 3ms.

**ISOLATION: Channel to Channel:** >10<sup>9</sup>Ω, <50pF.

**Common Mode:** >10<sup>9</sup>Ω, <100pF.

**CROSSTALK (1MHz, 50Ω load):** <-35dB.

**INSERTION LOSS (50Ω source, 50Ω load):** <0.3dB below 1MHz, <3dB below 10MHz.

**COMMON MODE VOLTAGE:** 300V between any terminal and chassis.

## GENERAL

**RELAY SWITCH CONFIGURATION:** 40 independent channels of 1-pole switching. Isolated from internal DMM.

**CONTACT CONFIGURATION:** 1 pole Form A.

**RELAY TYPE:** Latching electromechanical.

**CONNECTOR TYPE:** Two 50-pin female D-sub connectors.

**FIRMWARE:** Specified for Model 2700 rev. A01, 2701 rev. A01, and 2750 rev. A01 or higher.

## ENVIRONMENTAL

**OPERATING ENVIRONMENT:** Specified for 0°C to 50°C.  
Specified to 80% R.H. at 35°C.

**STORAGE ENVIRONMENT:** -25°C to 65°C.

**WEIGHT:** 0.45kg (1 lb).

## ACCESSORIES AVAILABLE

7705-MTC-2 50 Pin Male to Female D-sub Cable, 2m (6.6 ft).

## SERVICES AVAILABLE

7705-3Y-EW 1-year factory warranty extended to 3 years from date of shipment

1.888.KEITHLEY (U.S. only)

[www.keithley.com](http://www.keithley.com)

**KEITHLEY**

A Tektronix Company

A Greater Measure of Confidence

# 7706

# All-in-One I/O Module

20-channel Differential Multiplexer w/Automatic CJC, 16 Digital Outputs, 2 Analog Outputs, a Counter/Totalizer, and Screw Terminals

- 20 channels of analog input (w/automatic CJC) for general-purpose measurements
- 16 channels of digital output
- 2 analog outputs ( $\pm 12V$ , 5mA)
- 300V, 1A capacity; 60W, 125VA maximum
- Configurable as two independent banks of multiplexers
- Relay closures stored in onboard memory

## Ordering Information

7706 All-in-One I/O Module

## SERVICES AVAILABLE

7706-3Y-EW 1-year factory warranty extended to 3 years from date of shipment

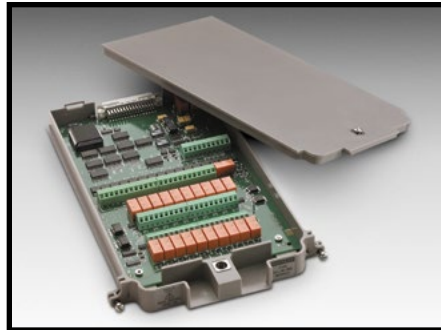

The Model 7706 plug-in module offers 20 channels of 2-pole or 10 channels of 4-pole multiplexer switching with automatic CJC, as well as two analog output channels, 16 digital outputs, and one event counter/totalizer. The event counter/totalizer can be used to monitor and control system components, such as fixtures, limit switches, pass/fail indicators, external voltage sources, loads, door closures, revolutions, etc., while performing mixed signal measurements. The Model 7706 is ideal for RTD, thermistor, and thermocouple temperature applications.

## CAPABILITIES

**CHANNELS 1–20:** Multiplex one of 20 2-pole or one of 10 4-pole signals into DMM.

Channels 21–25 are referenced to chassis ground.

**CHANNELS 21–22:** 16 Digital Outputs.

**CHANNELS 23–24:** Analog Voltage Output (2).

**CHANNELS 25:** Totalize Input.

## INPUTS

**MAXIMUM SIGNAL LEVEL (Channels 1–20):** 300V DC or rms, 1A switched, 60W, 125VA maximum.

**CONTACT LIFE (typ.):**  $>10^5$  operations at max. signal level;  $>10^8$  operations no load<sup>1</sup>.

<sup>1</sup>Minimum signal level 10mV, 10 $\mu$ A.

**CONTACT RESISTANCE:**  $<1\Omega$  at end of contact life.

**CONTACT POTENTIAL:**  $\leq \pm 2\mu V$  typical per contact, 3 $\mu V$  max.

**OFFSET CURRENT:**  $<100pA$ .

**CONNECTOR TYPE:** Screw terminal, #20 AWG wire size.

**ISOLATION BETWEEN ANY TWO TERMINALS:**  $>10^9\Omega$ ,  $<100pF$ .

**ISOLATION BETWEEN ANY TERMINAL AND EARTH:**  $>10^9\Omega$ ,  $<200pF$ .

**CROSS TALK (10MHz, 50 $\Omega$  Load):**  $<-35dB$ .

**INSERTION LOSS (50 $\Omega$  Source, 50 $\Omega$  Load):**  $<0.1dB$  below 1MHz.  $<3dB$  below 2MHz.

**COMMON MODE VOLTAGE:** 300V between any terminal and chassis.

**TEMPERATURE ACCURACY USING INTERNAL CJC:** 1.0°C (see mainframe specification for details).

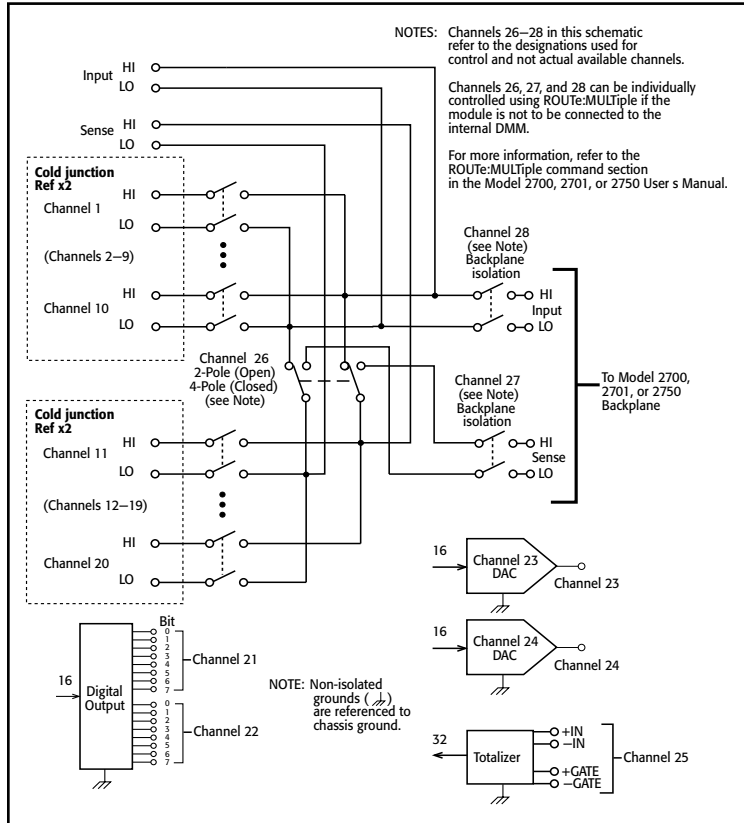

## TOTALIZE INPUT

**MAXIMUM COUNT:**  $2^{32}-1$ .

**TOTALIZE INPUT:** 100kHz (max), rising or falling edge, programmable.

**SIGNAL LEVEL:** 1Vp-p (min), 42Vpk (max).

**THRESHOLD:** 0V or TTL, jumper selectable.

**GATE INPUT:** TTL-Hi, TTL-Lo, or none.

**COUNT RESET:** Manual or Read+Reset.

**READ SPEED:** 50/s.

## ANALOG VOLTAGE OUTPUT

**DAC 1, 2:**  $\pm 12V$  in 1mV increments, non-isolated.

**RESOLUTION:** 1mV.

**I<sub>OUT</sub>:** 5mA max.

**SETTLING TIME:** 1ms to 0.01% of output.

**ACCURACY  $\pm$ (% of output + mV):**

1 year  $\pm 5^\circ C$ : 0.15% + 19mV;

90 day  $\pm 5^\circ C$ : 0.1% + 19mV;

24 hour  $\pm 1^\circ C$ : 0.04% + 19mV.

**TEMPERATURE COEFFICIENT:**

$\pm(0.015\% + 1mV)^\circ C$ .

## DIGITAL OUTPUT

**V<sub>OUT(L)</sub>:**  $<0.8V$  @ I<sub>out</sub> = 400mA.

**V<sub>OUT(H)</sub>:**  $>2.4V$  @ I<sub>out</sub> = 1mA.

**V<sub>OUT(H)MAX</sub>:**  $<42V$  with external open drain pull-up.

**WRITE SPEED:** 50/s.

## GENERAL

**20 CHANNELS:** 20 channels of 2-pole relay input. All channels configurable to 4-pole.

**RELAY TYPE:** Latching electromechanical.

**ACTUATION TIME:**  $<3ms$ .

**FIRMWARE:** Specified for Model 2700 rev. A02 or B01, 2701 rev. A01, and 2750 rev. A01 or higher.

## ENVIRONMENTAL

**OPERATING ENVIRONMENT:**

Specified for 0° to 50°C. Specified to 80% R.H. at 35°C.

**STORAGE ENVIRONMENT:**  $-25^\circ$  to  $65^\circ C$ .

**WEIGHT:** 0.5kg (1.1 lbs).

1.888.KEITHLEY (U.S. only)

www.keithley.com

KEITHLEY

A Greater Measure of Confidence

A Tektronix Company

Use with Integra Series mainframes: 2700, 2701, 2750

DIGITAL MULTIMETERS & SYSTEMS

# 7707

## 32-channel Digital I/O Module with 10-channel Differential Multiplexer

- 300V, 1A capacity; 60W, 125VA maximum (analog)
- 33V, 100mA capacity (digital)
- Digital outputs are short circuit protected
- Relay closures stored in onboard memory

### Ordering Information

**7707 32-channel Digital I/O Module with 10-channel Differential Multiplexer**

**Accessories Supplied**  
**Two mating IDC connectors**

### SERVICES AVAILABLE

7707-3Y-EW 1-year factory warranty extended to 3 years from date of shipment



The Model 7707 plug-in module offers 10 channels of 2-pole or 5 channels of 4-pole multiplexer switching that can be configured as two independent banks of multiplexers. The Model 7707 also provides 32 digital input/output channels (four 8-bit ports) for I/O control. Connect the Model 7707 to industry standard solid-state relays to switch up to 980VA.

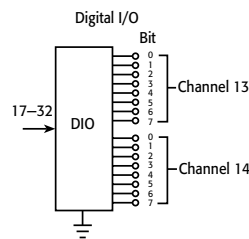
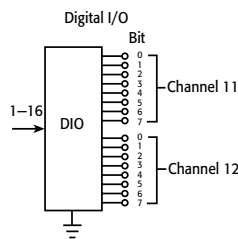
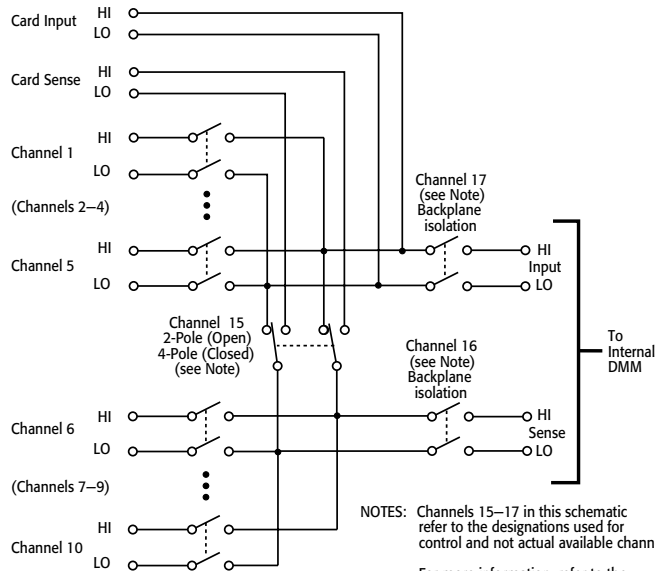

### CAPABILITIES

**CHANNELS 1-10:** Multiplex one of 10 2-pole or one of 5 4-pole signals into DMM.

**CHANNELS 11-14:** 32 Digital Inputs/Outputs referenced to chassis ground.

**THERMAL PROTECTION:** Channels 11-14 are thermally protected to 1A.

### INPUTS (Channels 1-10)

**MAXIMUM SIGNAL LEVEL:** Any Channel to Any Channel (1-10): 300VDC or 300Vrms (425V peak) for AC waveforms, 1A switched, 60W, 125VA maximum.

**SAFETY CATEGORY:** Conforms to European Union Directive 73/23/EEC EN 61010-1, CAT I.

**CONTACT LIFE (typ.):** >10<sup>5</sup> operations at max. signal level: >10<sup>8</sup> operations no load<sup>1</sup>.

<sup>1</sup>Minimum signal level 10mV, 10μA.

**CONTACT RESISTANCE:** <1Ω any path and additional 1Ω at end of contact life.

**CONTACT POTENTIAL:** <6μV typical per contact pair and additional 5μV with Channels 11-14 at rate V<sub>OUT</sub>(L).

**OFFSET CURRENT:** <100pA.

**CONNECTOR TYPE:** 50-pin male D-shell, Channels 11-14. 25-pin female D-shell, Channels 1-10. Supplied with female and male IDC ribbon cable connectors.

**ISOLATION BETWEEN ANY TWO TERMINALS:** >10<sup>9</sup>Ω, <100pF with isolation channels 16 and 17 open.

**ISOLATION BETWEEN ANY TERMINAL AND EARTH:** >10<sup>9</sup>Ω, <200pF.

**CROSS TALK (10MHz, 50Ω Load):** <-35dB.

**INSERTION LOSS (50Ω Source, 50Ω Load):** <0.1dB below 1MHz. <3dB below 2MHz.

**COMMON MODE VOLTAGE:** 300VDC or 300Vrms (425V peak) for AC waveforms between any terminal and chassis.

### DIGITAL INPUT/OUTPUT (Channels 11-14)

V<sub>IN</sub>(L): <0.8V (TTL).

V<sub>IN</sub>(H): >2V (TTL).

V<sub>OUT</sub>(L): <1.0V @ I<sub>OUT</sub> = 100mA.

V<sub>OUT</sub>(H): >2.4V @ I<sub>OUT</sub> = 1mA.

V<sub>OUT</sub>(H)MAX.: <40V with external open drain pull-up.

READ/WRITE SPEED: 50/s.

### GENERAL

**10 CHANNELS:** 10 channels of 2-pole relay input. All channels configurable to 4-pole.

**RELAY TYPE:** Latching electromechanical.

**ACTUATION TIME:** <3ms.

**FIRMWARE:** Specified for Model 2700 rev. B03, 2701 rev. A01, and 2750 rev. A01 or higher.

**CAPACITY: Model 2700:** (1) 7707 and (1) 77XX, except 7706.

**Model 2701:** Any combination of 77XX modules.

**Model 2750:** (4) 7707 and (1) 77XX, except 7706.

A 7706 module may be substituted for a 7707 module.

### ENVIRONMENTAL

**OPERATING ENVIRONMENT:** Specified for 0°C to 50°C.

Specified to 50% R.H. at 35°C.

**STORAGE ENVIRONMENT:** -25°C to 65°C.

**WEIGHT:** <0.5kg (1.1 lbs).

### ACCESSORIES AVAILABLE

7790	50/50/25 Pin Female/Male D-Shell IDC Connectors
7705-MTC-2	50 Pin Male to Female D-sub Cable, 2m (6.6 ft).
7707-MTC-2	25 Pin Male to Female D-sub Cable, 2m (6.6 ft).

1.888.KEITHLEY (U.S. only)

www.keithley.com

**KEITHLEY**

A Greater Measure of Confidence

A Tektronix Company

# 7708

## 40-channel Differential Multiplexer Module with Automatic CJC and Screw Terminals

- 40 differential channels for general-purpose measurements
- Two- or four-wire measurements
- 300V, 1A capacity for voltage channels; 60W, 125VA
- Oversize screw terminal connection blocks are standard for easier connection
- Relay closures stored in onboard memory

### Ordering Information

**7708** 40-channel Differential Multiplexer Module with Automatic CJC and Screw Terminals

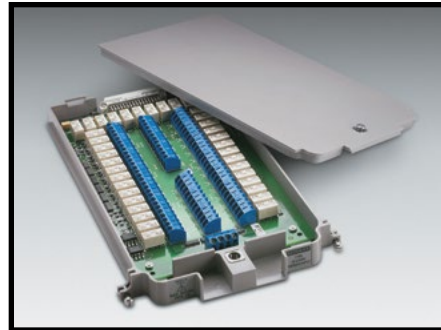

The Model 7708 plug-in module offers 40 channels of 2-pole or 20 channels of 4-pole multiplexer switching that can be configured as two independent banks of multiplexers. The built-in CJC sensors automatically linearize thermocouples, making the Model 7708 ideal for RTD, thermistor, and thermocouple temperature applications. It is also well suited for mixed-signal measurement applications that require multi-point monitoring, such as environmental stress screening.

### CAPABILITIES

**CHANNELS 1–40:** Multiplex one of 40 2-pole or one of 20 4-pole signals into DMM.

### INPUTS

#### MAXIMUM SIGNAL LEVEL:

**Channels (1–40):** 300V DC or rms, 1A switched, 60W, 125VA maximum.

**CONTACT LIFE (typ):** >10<sup>5</sup> operations at max. signal level.  
>10<sup>8</sup> operations no load<sup>1</sup>.

<sup>1</sup> Open thermocouple detector on during thermocouple measurements. Minimum signal level 10mV, 10μA.

**CONTACT RESISTANCE:** <1Ω at end of contact life.

#### CONTACT POTENTIAL:

<±500nV typical per contact, 1μV max.  
<±500nV typical per contact pair, 1μV max.

**OFFSET CURRENT:** <100pA.

**CONNECTOR TYPE:** Screw terminal, #20 AWG wire size.

**ISOLATION BETWEEN ANY TWO TERMINALS:** >10<sup>10</sup>Ω,  
<100pF.

**ISOLATION BETWEEN ANY TERMINAL AND EARTH:** >10<sup>10</sup>Ω,  
<200pF.

**CROSS TALK (10MHz, 50Ω Load):** <–40dB.

**INSERTION LOSS (50Ω Source, 50Ω Load):** <0.1dB below  
1MHz. <3dB below 2MHz.

**COMMON MODE VOLTAGE:** 300V between any terminal and chassis.

#### TEMPERATURE ACCURACY USING INTERNAL CJC:

1.0°C (see mainframe specification for details).

### GENERAL

**40 CHANNELS:** 40 channels of 2-pole relay input. All channels configurable to 4-pole.

**RELAY TYPE:** Latching electromechanical.

**ACTUATION TIME:** <3ms.

**FIRMWARE:** Specified for Model 2700 rev. B02, 2701 rev. A01, and 2750 rev. A01 or higher.

### ENVIRONMENTAL

**OPERATING ENVIRONMENT:** Specified for 0°C to 50°C.  
Specified to 80% R.H. at 35°C.

**STORAGE ENVIRONMENT:** –25°C to 65°C.

**WEIGHT:** 0.52kg (1.16 lb).

### ACCESSORIES AVAILABLE

7401 Type K Thermocouple Wire, 30.5m (100 ft).

### SERVICES AVAILABLE

7708-3Y-EW 1-year factory warranty extended to 3 years from date of shipment

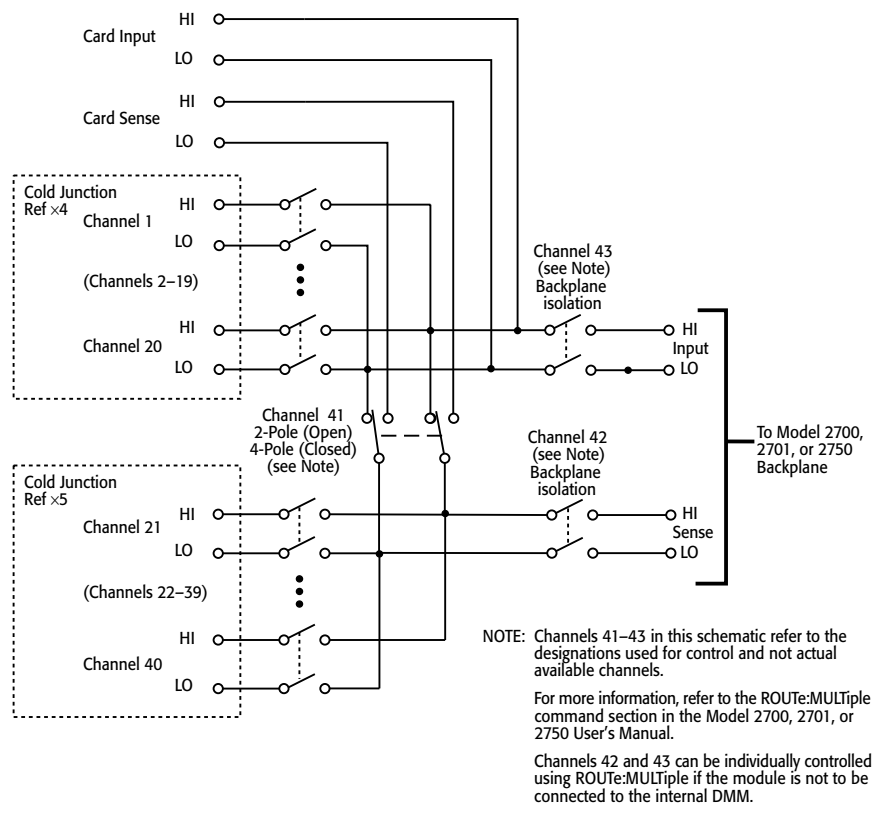

1.888.KEITHLEY (U.S. only)

www.keithley.com

**KEITHLEY**

A Greater Measure of Confidence

A Tektronix Company

Use with Integra Series mainframes: 2700, 2701, 2750

DIGITAL MULTIMETERS & SYSTEMS

## 7709

## 6×8 Matrix Module

- Automatic two- or four-wire connection to DMM
- 6 row × 8 column matrix
- Expandable to larger switch configurations by daisy-chaining or cascading multiple modules
- Two female D-sub connectors are standard for secure hook-up and quick teardown
- 300V, 1A capacity
- Relay closures stored in onboard memory

## Ordering Information

7709 6×8 Matrix Module

## Accessories Supplied

Two mating IDC connectors



The Model 7709 plug-in module is a two-pole, 6×8 matrix module. It can connect any combination of six differential channels of instrumentation to any combination of eight differential device-under-test channels. The instrumentation can be AC and DC sources, internal or external meters, oscilloscopes, etc. This matrix configuration allows wide flexibility for complex test systems.

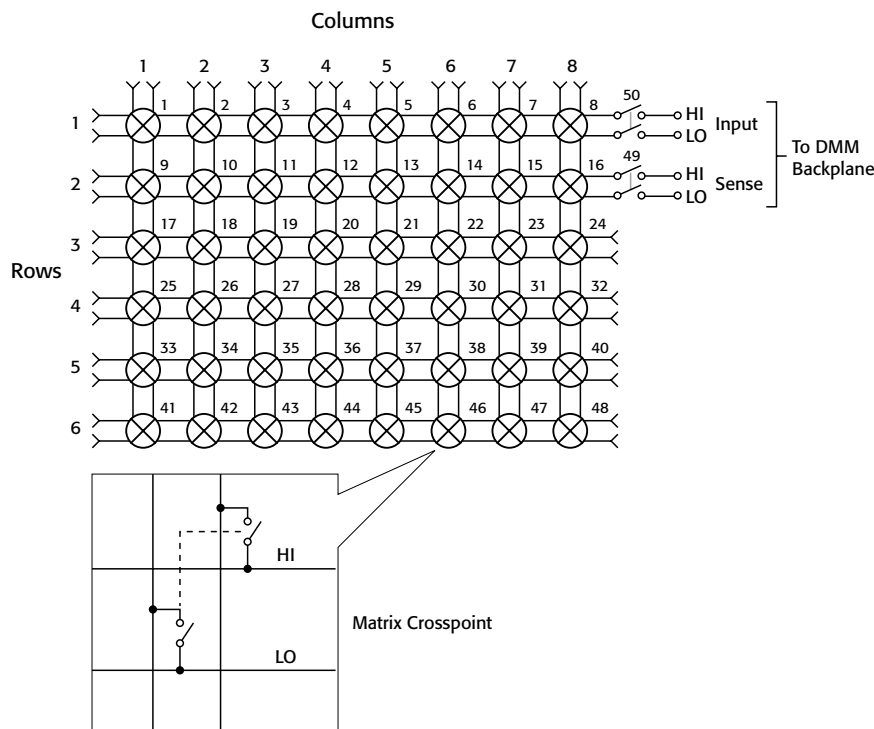

## CAPABILITIES

## DMM CONNECTION:

## 2-Wire Functions

Row 1, channels 1–8, through channel 50.

## 4-Wire Functions

Row 1, channels 1–4 (Source) through channel 50 and  
Row 2, channels 13–16 (Sense), through channel 49.

**CLOSE CHANNEL:** CLOSE command connects channels 1–8 to DMM. For 4-wire, channels 1–4 are automatically paired with channels 13–16. **ROUTE:MULTIPLE** allows any combination of rows and columns to be connected at the same time.

## INPUTS

**MAXIMUM SIGNAL LEVEL: Any Channel to Any Channel (1–48):** 300VDC or 300Vrms (425V peak) for AC waveforms, 1A switched, 60W, 125VA maximum.

**SAFETY:** Conforms to European Union Directive 73/23/EEC EN61010-1, CAT I.

**CONTACT LIFE (typ):** >10<sup>5</sup> operations at max. signal level.  
>10<sup>8</sup> operations no load<sup>1</sup>.

<sup>1</sup> Minimum signal level 10mV, 10μA.

**CONTACT RESISTANCE:** <1Ω any path and additional 1Ω at end of contact life.

**CONTACT POTENTIAL:** <3μV per contact pair.

**OFFSET CURRENT:** <100pA.

**CONNECTOR TYPE:** 50-pin female D-shell for rows and columns.  
25-pin female D-shell for “daisy-chain” rows.  
Supplied with male IDC ribbon cable connectors.

**ISOLATION BETWEEN ANY TWO TERMINALS:** >10<sup>9</sup>Ω,  
<200pF.

**ISOLATION BETWEEN ANY TERMINAL AND EARTH:** >10<sup>9</sup>Ω,  
<400pF.

**CROSS TALK (1MHz, 50Ω Load):** <–35dB.

**INSERTION LOSS (50Ω Source, 50Ω Load):** <0.35dB below  
1MHz. <3dB below 2MHz.

**COMMON MODE VOLTAGE:** 300VDC or 300Vrms (425V peak)  
for AC waveforms between any terminal and chassis.

## GENERAL

**MATRIX CONFIGURATION:** 6 rows × 8 columns.

**CONTACT CONFIGURATION:** 2 pole Form A.

**FIRMWARE:** Specified for Model 2700 rev. B03, Model 2701 rev. A01, and Model 2750 rev. A01 or higher.

**RELAY TYPE:** Latching electromechanical.

**ACTUATION TIME:** <3ms.

## ENVIRONMENTAL

**OPERATING ENVIRONMENT:** Specified for 0°C to 50°C.  
Specified to 50% R.H. at 35°C.

**STORAGE ENVIRONMENT:** –25°C to 65°C.

**WEIGHT:** <0.52kg (1.16 lb).

## ACCESSORIES AVAILABLE

7789	50/25 Pin Male D-Shell Solder Cup Connectors
7790	50/50/25 Pin Female/Male D-Shell IDC Connectors
7705-MTC-2	50 Pin Male to Female D-sub Cable, 2m (6.6 ft).
7707-MTC-2	25 Pin Male to Female D-sub Cable, 2m (6.6 ft).

## SERVICES AVAILABLE

7709-3Y-EW	1-year factory warranty extended to 3 years from date of shipment
------------	---

1.888.KEITHLEY (U.S. only)

www.keithley.com

KEITHLEY

A Greater Measure of Confidence

A Tektronix Company

# 7710

## 20-channel Solid-state Differential Multiplexer with Automatic CJC

- 20 channels for general purpose measurements
- Scanning speeds of up to 500 channels/second
- High speed production or ATE testing up to 500 channels/s
- Long lifetime solid state relay
- Removable screw terminals for simple, quick connections

### Ordering Information

**7710** 20-channel Solid-state Differential Multiplexer Module

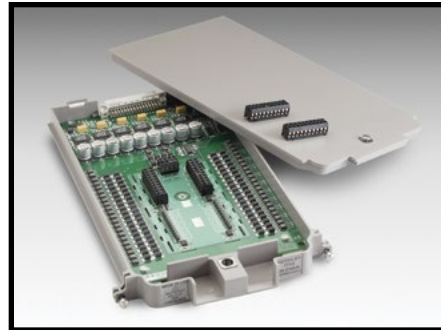

The Model 7710 plug-in module offers 20 channels of 2-pole or 10 channels of 4-pole relay input that can be configured as two independent banks of multiplexers. The relays are solid state, providing long life and low maintenance. Solid-state relays usually have 100 times longer life than mechanical relays. It is ideal for long-term data logging applications as well as for demanding high-speed applications.

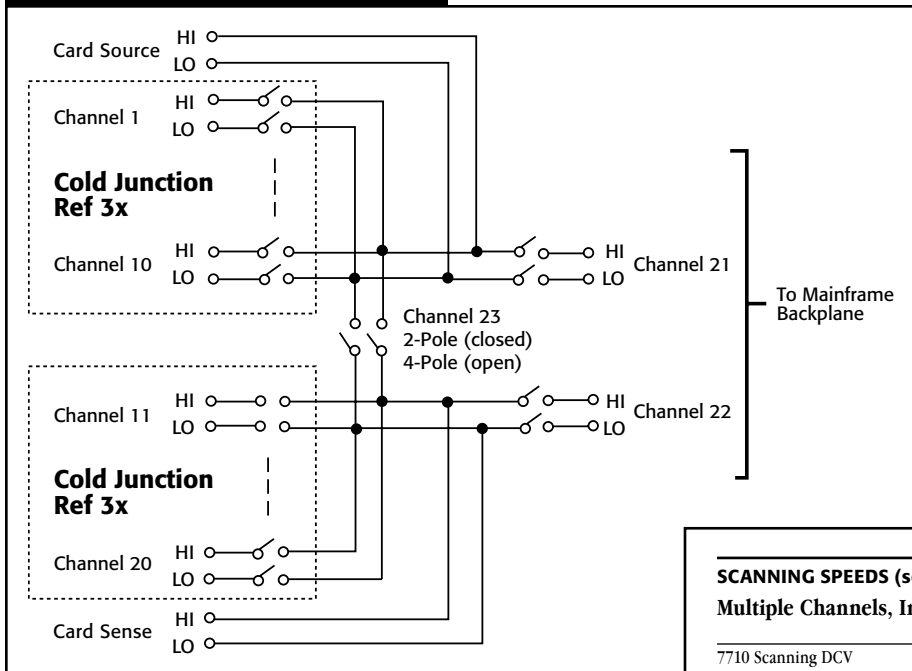

### ACCESSORIES AVAILABLE

7401 Type K Thermocouple Wire, 30.5m (100 ft).

### SERVICES AVAILABLE

7710-3Y-EW 1-year factory warranty extended to 3 years from date of shipment

### CAPABILITIES

**CHANNELS 1–20:** Multiplex one of 20 2-pole or one of 10 4-pole signals into DMM.

### INPUTS

**MAXIMUM SIGNAL LEVEL:** Any channel to any channel (1–20): 60VDC or 42V rms, 100mA switched, 6W, 4.2VA maximum.

**COMMON MODE VOLTAGE:** 300VDC or 300Vrms (425V peak) maximum between any terminal and chassis.

**RELAY LIFE (TYP):** >10<sup>8</sup> operational hours max. signal level or 10<sup>10</sup> operations (guaranteed by design).

**RELAY DRIVE CURRENT:** 6mA per channel continuous, 25mA during initial pulse.

**CHANNEL RESISTANCE (per conductor):** <5Ω.

**CONTACT POTENTIAL:** <1μV per pair.

**OFFSET CURRENT:** <3nA @ 23°C (per channel); additional 0.13nA/°C >23°C.

**CONNECTOR TYPE:** 3.5mm removable screw terminals, #20 AWG wire size.

**ISOLATION BETWEEN ANY TWO TERMINALS:** >10<sup>9</sup>Ω, <100pF.

**ISOLATION BETWEEN ANY TERMINAL AND EARTH:** >10<sup>9</sup>Ω, <100pF.

**CROSSTALK (CH-CH, 300kHz, 50Ω Load):** <–40dB.

**INSERTION LOSS (50Ω Source, 50Ω Load):** <0.5dB below 100kHz, <3dB below 2MHz.

**TEMPERATURE ACCURACY USING INTERNAL CJC:** 1°C for K type (see mainframe specifications for details).

### GENERAL

**CHANNELS:** 20 channels of 2-pole relay input. All channels configurable to 4-pole.

**RELAY TYPE:** Solid State Opto-Coupled FET.

**ACTUATION TIME:** <0.5ms (100mA load).

**FIRMWARE:** Specified for Model 2700 Rev. B05, Model 2750 Rev. A04, and Model 2701 Rev. A01.

### ENVIRONMENTAL

**OPERATING ENVIRONMENT:** Specified for 0°C to 50°C. Specified for 80% R.H. at 35°C.

**STORAGE ENVIRONMENT:** –25° to 65°C.

**WEIGHT:** 0.45kg (1 lb).

### SCANNING SPEEDS (see mainframe specifications for details)

**Multiple Channels, Into Memory**

	Channels/s		
	2700	2701	2750
7710 Scanning DCV	180/s	500/s	230/s
7710 Scanning DCV with Limits or Time Stamp On	170/s	500/s	230/s
7710 Scanning DCV alternating 2WΩ	45/s	130/s	60/s

**Multiple Channels, Into and Out of Memory to GPIB or Ethernet**

	Channels/s		
	2700	2701	2750
7710 Scanning DCV	145/s	440/s	210/s
7710 Scanning DCV with Limits or Time Stamp On	145/s	440/s	210/s
7710 Scanning DCV alternating 2WΩ	40/s	130/s	55/s

1.888.KEITHLEY (U.S. only)

www.keithley.com

A Greater Measure of Confidence

**KEITHLEY**

A Tektronix Company

Use with Integra Series mainframes: 2700, 2701, 2750

DIGITAL MULTIMETERS & SYSTEMS



**7711**

# 2GHz 50Ω RF Module

- Signal routing performance to 2GHz
- Switches up to 60VDC
- Rear panel SMA connections
- Onboard switch closure counter
- Onboard S parameter storage

## Ordering Information

**7711 2GHz 50Ω RF Module**

The Model 7711 plug-in module provides an economical, wideband signal routing solution that complements the DC/low frequency switching and measurement capability of the Integra Series systems. The Model 7711 offers dual 1×4 configurations and can interface with a wide range of external AC instruments, including oscilloscopes, pulse generators, and signal analysis tools. One channel in each multiplex bank is always closed to the corresponding OUT connector. All connections are easily accessible from the rear panel.

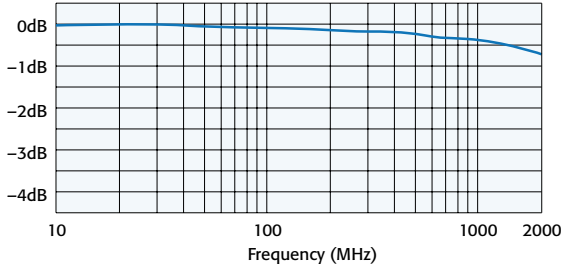
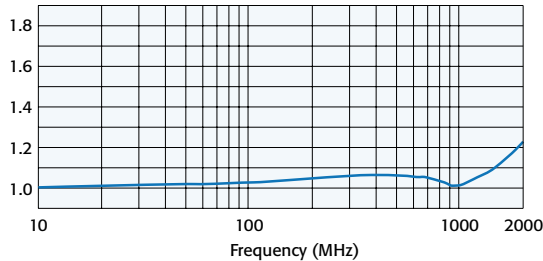
**Typical Insertion Loss****Typical VSWR****AC PERFORMANCE (END OF LIFE)**For  $Z_{load} = Z_{source} = 50\Omega$ 

	<100 MHz	500 MHz	1 GHz	1.5 GHz	2 GHz
<b>Insertion Loss</b>	<0.4 dB	<0.6 dB	<1.0 dB	<1.2 dB	<2.0 dB
<b>Max.</b>					
<b>VSWR Max.</b>	<1.1	<1.2	<1.2	<1.3	<1.7 <sup>2</sup>
<b>Ch-Ch Crosstalk<sup>1</sup></b>	-85 dB	-65 dB	-55 dB	-45 dB	-35 dB
<b>Max.</b>					

<sup>1</sup> Specification assumes 50Ω termination.<sup>2</sup> Add 0.1VSWR after  $5 \times 10^5$  closures (no load).**SERVICES AVAILABLE**

7711-3Y-EW 1-year factory warranty extended to 3 years from date of shipment

**INPUTS (Channels 1–8)****MAXIMUM SIGNAL LEVEL:** Any channel to any channel or chassis (1–8): 30Vrms (42V peak for AC waveforms) or 60VDC, 0.5A.**MAXIMUM POWER:** 20W per module, 10W per channel (refer to 7711/7712 Manual PA-818 for measurement considerations).**SAFETY:** Conforms to European Union Directive 73/23/EEC EN61010-1, CAT I.**EMC:** Conforms with European Union Directive 89/336/EEC; EN61326-1.**ISOLATION: Multiplexer to Multiplexer:** >1GΩ.**Center to Shield:** >1GΩ, <25pF.**Channel to Channel:** >100MΩ.**CONTACT LIFE:**  $1 \times 10^6$  no load,  $1 \times 10^5$  rated load (resistive load).**CONTACT POTENTIAL:** <6μV.**CONTACT RESISTANCE:** <0.5Ω (initial), <1Ω (end of life).**RISE TIME:** <300ps (guaranteed by design).**SIGNAL DELAY:** <3ns.**GENERAL****RELAY TYPE:** High frequency electromechanical.**CONTACT CONFIGURATION:** Dual 1×4 multiplexer, single pole four throw, Channels 1 and 5 are normally closed. **NOTE:** One channel in each multiplex bank is always closed to the corresponding OUT connector.**CLOSE CHANNEL:** ROUTe:CLOSe allows a single channel in a multiplex bank to be closed.

ROUTe:MULTIple:CLOSe allows two channels (one in each bank) to be closed at one time.

**OPEN CHANNEL:** ROUTe:OPeN:ALL closes CH1 and CH5 to OUT A and OUT B respectively.**ACTUATION TIME:** <10ms.**FIRMWARE:** Specified for Model 2700 rev. B04, 2701 rev. A01, and 2750 rev. A03 or higher.**CONNECTOR TYPE:** Ten external rear panel SMA connectors.**MATING TORQUE:** 0.9 N·m (8 in-lb).**ENVIRONMENTAL****OPERATING ENVIRONMENT:** Specified for 0°C to 50°C. Specified for 80% RH at 35°C.**STORAGE ENVIRONMENT:** -25°C to 65°C.**WEIGHT:** <0.5kg (1.1 lb).**ACCESSORIES AVAILABLE**

7051-2	BNC Cable, male to male, 0.6m (2 ft.)
7051-5	BNC Cable, male to male, 1.5m (5 ft.)
7051-10	BNC Cable, male to male, 3.0m (10 ft.)
7711-BNC-SMA	Male SMA to female BNC Cables (5), 0.15m (0.5 ft.)
7712-SMA-1	SMA Cable, male to male, 1m (3.3 ft.)
7712-SMA-N	Female SMA to Male N-Type Adapter
S46-SMA-0.5	SMA Cable, male to male, 0.15m (0.5 ft.)
S46-SMA-1	SMA Cable, male to male, 0.3m (1 ft.)

**1.888.KEITHLEY** (U.S. only)**www.keithley.com****KEITHLEY**

A Greater Measure of Confidence

A Tektronix Company

# 7712

## 3.5GHz 50Ω RF Module

- 3.5GHz bandwidth
- Dual 1x4 configuration
- Onboard switch closure counter
- Onboard S parameter storage

### Ordering Information

7712 3.5GHz 50Ω RF Module



The Model 7712 plug-in module offers a 50Ω dual 14 multiplexer configuration with rear panel SMA 14 connectors. Multiple multiplexers can be cascaded to build scalable matrix and multiplexer systems for a large number of devices under test and RF source/measurement instruments. One channel in each multiplex bank is always closed to the corresponding OUT connector. The 3.5GHz RF switching capability of the Model 7712 makes it ideal for applications such as 3G telecom, wireless LAN, and Bluetooth module testing.

Typical Insertion Loss

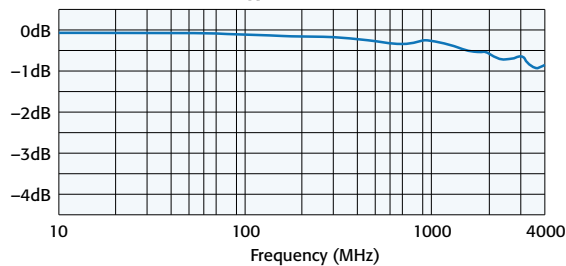

Typical VSWR

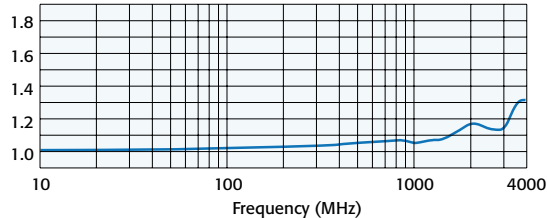

### AC PERFORMANCE (End of Life)

For  $Z_{load} = Z_{source} = 50\Omega$

	<500 MHz	1 GHz	2.4 GHz	3.5 GHz
Insertion Loss	<0.5 dB	<0.65 dB	<1.1 dB	<1.3 dB
Max.				
VSWR MAX	<1.15	<1.2	<1.45 <sup>2</sup>	<1.45
Ch-Ch Crosstalk <sup>1</sup>	-75 dB	-70 dB	-50 dB	-45 dB
Max.				

<sup>1</sup> Specification assumes 50Ω termination.

<sup>2</sup> Add 0.1VSWR after  $5 \times 10^5$  closures (no load).

### INPUTS (Channels 1–8)

**MAXIMUM SIGNAL LEVEL:** Any channel to any channel or chassis (1–8): 30Vrms (42V peak for AC waveforms) or 42VDC, 0.5A.

**MAXIMUM POWER:** 20W per module, 10W per channel (refer to 7711/7712 Manual PA-818 for measurement considerations).

**SAFETY:** Conforms to European Union Directive 73/23/EEC EN61010-1, CAT I.

**EMC:** Conforms with European Union Directive 89/336/EEC; EN61326-1.

**ISOLATION: Multiplexer to Multiplexer:** >1GΩ.

**Center to Shield:** >1GΩ, <20pF.

**Channel to Channel:** >100MΩ.

**CONTACT LIFE:**  $5 \times 10^6$  no load,  $1 \times 10^5$  rated load (resistive load).

**CONTACT POTENTIAL:** <12μV.

**CONTACT RESISTANCE:** <0.5Ω (initial), <1Ω (end of life).

**RISE TIME:** <200ps (guaranteed by design).

**SIGNAL DELAY:** <1.5ns.

### GENERAL

**RELAY TYPE:** High frequency electromechanical.

**CONTACT CONFIGURATION:** Dual 1x4 multiplexer, single pole four throw, Channels 1 and 5 are normally closed.

**NOTE:** One channel in each multiplex bank is always closed to the corresponding OUT connector.

**CLOSE CHANNEL:** ROUTe:CLOSe allows a single channel in a multiplex bank to be closed.

ROUTe:MULTiple:CLOSe allows two channels (one in each bank) to be closed at one time.

**OPEN CHANNEL:** ROUTe:OPeN:ALL closes CH1 and CH5 to OUT A and OUT B respectively.

**ACTUATION TIME:** <10ms.

**FIRMWARE:** Specified for Model 2700 rev. B04, 2701 rev. A01, and 2750 rev. A03 or higher.

**CONNECTOR TYPE:** Ten external rear panel SMA connectors.

**MATING TORQUE:** 0.9 N·m (8 in·lb).

### ENVIRONMENTAL

**OPERATING ENVIRONMENT:** Specified for 0°C to 50°C. Specified for 80% RH at 35°C.

**STORAGE ENVIRONMENT:** -25°C to 65°C.

**WEIGHT:** <0.5kg (1.1 lb).

### ACCESSORIES AVAILABLE

7712-SMA-1	SMA Cable, male to male, 1m (3.3 ft)
7712-SMA-N	Female SMA to Male N-Type Adapter
S46-SMA-0.5	SMA Cable, male to male, 0.15m (0.5 ft)
S46-SMA-1	SMA Cable, male to male, 0.3m (1 ft)

### SERVICES AVAILABLE

7712-3Y-EW	1-year factory warranty extended to 3 years from date of shipment
------------	---

1.888.KEITHLEY (U.S. only)

www.keithley.com

KEITHLEY

A Greater Measure of Confidence

A Tektronix Company

# Free Bundled Software

## For the Integra Series (Models 2700, 2701, and 2750)

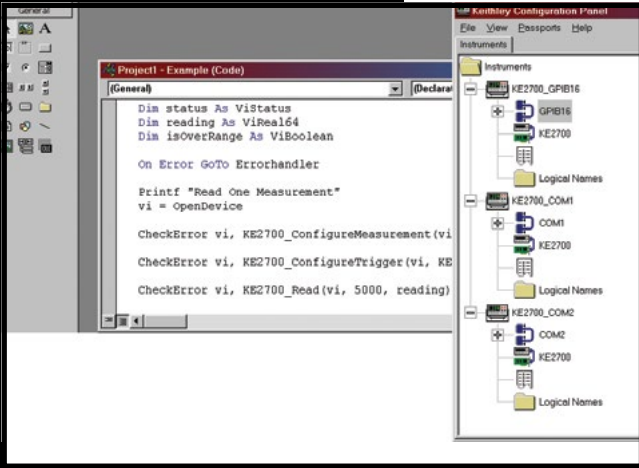

### IVI (Interchangeable Virtual Instruments) Drivers

Developers often prefer to create their own custom applications. The Integra Series instruments supply IVI device drivers that support many application development environments including LabVIEW®, LabWindows/CVI, Visual Basic, and C/C++. These IVI drivers are VISA based and support all the functionality of the Model 2700/2701/2750. Numerous examples are supplied as well as an online help utility.

#### IVI Drivers

- LabVIEW drivers
- LabWindows/CVI drivers
- Visual Basic, C/C++ drivers

#### ExceLINX-1A

- Microsoft Excel add-in utility
- Acquire data for 2700, 2701, and 2750 systems
- Configure channels, parameters, triggers, and scan lists

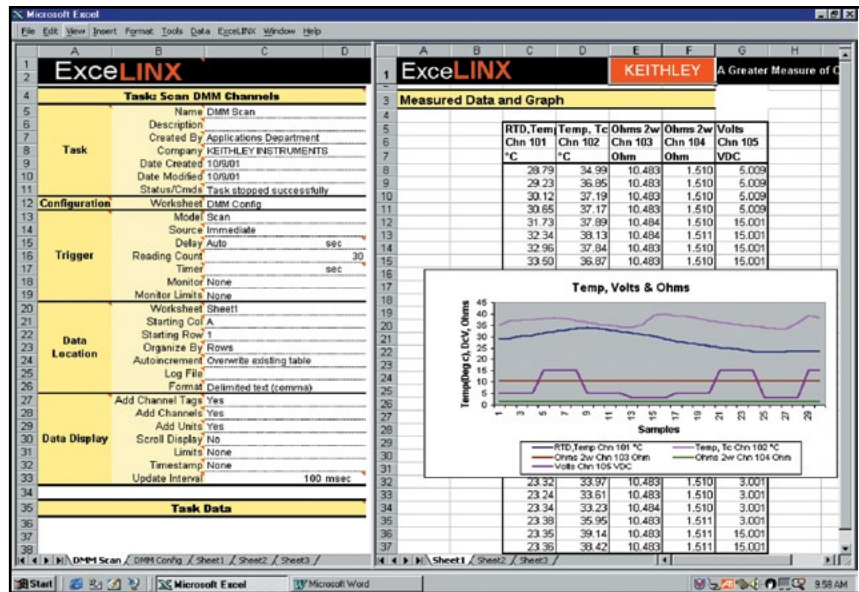

ExceLINX-1A is an easy-to-use add-in utility for Microsoft® Excel and Integra systems. No programming is required; enter values quickly through pop-up menus and eliminate time-consuming coding.

### Minimum System Requirements

	Windows 2000	XP	Vista	Windows 7 (32-bit)	Windows 7 (64-bit)
IVI Instrument Drivers	Yes	Yes	Yes	Yes	Yes (but only as 32-bit applications)
ExceLINX-1A	Yes	Yes	Yes	Yes	Yes (but only as 32-bit applications)

1.888.KEITHLEY (U.S. only)

[www.keithley.com](http://www.keithley.com)



A Greater Measure of Confidence

A Tektronix Company

# ExcelINX™ -1A

## Excel Add-In

For the Integra Series (Models 2700, 2701, and 2750)

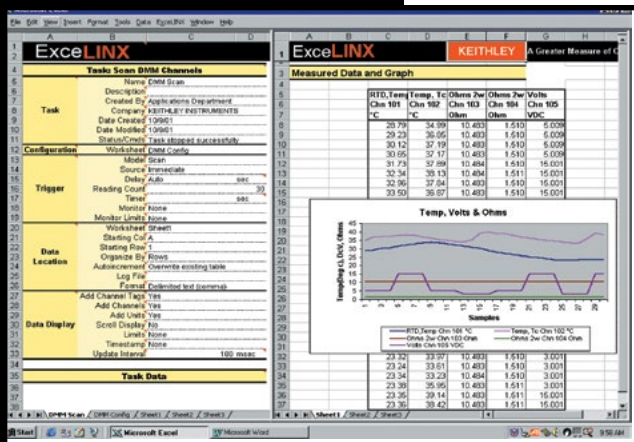

### ExcelINX-1A

- Stream data directly into Excel spreadsheets
- No programming required
- Get data with only a few mouse clicks
- Temperature, voltage, current, and resistance measurement capabilities
- Different functions can be supported on each channel
- Scaling, filtering, and limit capabilities
- GPIB, Ethernet, and RS-232 compatible
- Online help

ExcelINX-1A is an easy to use add-in utility for Microsoft® Excel and Keithley's Integra Series Multimeter/Switch Systems. Within minutes of installing ExcelINX on a PC, users can stream data directly from the Model 2700/2701/2750 into Excel. Data can be analyzed as it is received in Excel with Excel's graphics, charting, and mathematical capabilities, so a user can closely monitor the application in progress.

No programming is required to use ExcelINX-1A. A few mouse clicks are all it takes to configure channels, set parameters, select a trigger source, define scan lists, etc. Pop-up menus are used to set values and to determine whether data should move from the Model 2700/2701/2750 to Excel in real time during a scan or after the scan has completed.

ExcelINX-1A also supports many communication interfaces, including GPIB boards from Keithley, CEC, National Instruments, and INES.

### Easy to Use

With ExcelINX-1A, no programming is required. To use it, simply perform the following steps.

1. Select the task (such as DMM scan) from a pop-up menu. A template will display.
2. Either use the template's default values (such as how many samples and which channels) or enter values.
3. Select the Integra system from the pop-up menu of installed systems.
4. Press Go on the ExcelINX-1A toolbar.

As soon as ExcelINX-1A receives data, it immediately sends the data directly to the Excel spreadsheet.

At the same time that ExcelINX-1A is acquiring data and sending it to the Excel spreadsheet, Excel is processing the data. For example, Excel could be performing calculations and displaying the results on a graph as it receives the data. The user can see the graph being updated while data is being collected.

Because ExcelINX-1A is an Excel add-in, it does not have the limitations that a separate package has. For example, many of these packages use DDE or OLE to send data to Excel, but DDE and OLE can only send limited amounts of data and can be cumbersome to use.

### Firmware and Card Requirements

- Model 2700 (Firmware B03 or newer version), Model 2701, or Model 2750 (Firmware A02 or a newer version)
- Supports Integra Series 77xx plug-in/control modules and their common functions
  - Model 7700 20-channel, Differential Multiplexer Module with Automatic CJC and Screw Terminals
  - Model 7701 32-channel Differential Multiplexer Module
  - Model 7702 40-channel Differential Multiplexer Module with Screw Terminals
  - Model 7703 32-channel, High-Speed, Differential Multiplexer Module
  - Model 7705 40-channel Single-pole Control Module
  - Model 7707 32-channel Digital I/O Module with 10-channel Differential Multiplexer
  - Model 7708 40-channel Differential Multiplexer Module with Automatic CJC and Screw Terminals
  - Model 7709 68 Matrix Module
  - Model 7710 20-channel Solid-state Differential Multiplexer with Automatic CJC
  - Model 7711 2GHz 50 RF Module
  - Model 7712 3.5GHz 50 RF Module

1.888.KEITHLEY (U.S. only)

[www.keithley.com](http://www.keithley.com)

**KEITHLEY**

A Greater Measure of Confidence

A Tektronix Company

Streams data directly to Excel

DIGITAL MULTIMETERS & SYSTEMS

2790

## SourceMeter® Airbag Test System



- Single-instrument solution for continuity and hi-pot type leakage resistance measurements
- Programmable constant V source (50–500V) supports high speed, high resistance measurements
- Programmable constant I source (0–50mA) with dry circuit clamp helps prevent device stress or damage during low resistance measurements
- Modular architecture adapts easily to single or dual inflator testing and to single or dual position test stands and mixed device/signal applications
- Expandable multiplexer channels for multipin applications
- Included 6½-digit DMM with wide functionality and broad measurement ranges
- Intelligent automation support and easy integration with external test hardware
- GPIB, RS-232, and digital I/O interfaces for flexible controller options
- SCPI programmable for simple code development and future extensions
- 2-year calibration cycle of modules minimizes maintenance costs and system downtime

The Model 2790 SourceMeter Switch System is a high voltage, multichannel resistance measurement solution that speeds and simplifies electrical checks of airbag inflators and a variety of other automotive electrical test applications. It is the only commercial instrument that combines all the sourcing, measurement, and signal routing capabilities required to measure insulation resistance and conductor continuity in one compact, affordable package. Through the use of plug-in source/switch modules, the Model 2790 provides programmable high voltage and low current sourcing, plus multichannel switching support. This unique combination of capabilities establishes a new standard for price and performance in airbag inflator and other test applications.

### Measure Extreme Resistances with Constant Current or Constant Voltage

The Model 2790 uses the forced constant-current method to measure resistances less than  $1\text{k}\Omega$ . In this technique, the instrument sources a constant current (I) to the resistance and measures the resulting voltage (V). The amount of current sourced is programmable from 0–50mA. Resistance (R) is calculated (and displayed) using the known current and measured voltage ( $R = V/I$ ). A 20mV dry circuit clamp is available at sourcing levels up to 1mA for preserving the oxide layers on connectors and other components.

For the  $1\text{M}\Omega$  to  $1\text{G}\Omega$  resistance ranges, the forced constant-voltage method is used to measure high resistance. This technique optimizes settling

speed and reduces noise, allowing faster, high quality insulation resistance measurements. In addition, by applying high voltages (50–500V), the Model 2790 stresses a dielectric while simultaneously measuring its insulation resistance.

In addition to the resistance measurement functions available through the plug-in source/switch modules, the Model 2790's built-in DMM allows it to make a full range of high precision resistance measurements as well as AC/DC voltage and current, frequency, and temperature measurements. These DMM functions are available either through front panel jacks or through the addition of a Model 7702 40-channel scanner module. In addition to the shorts/open testing performed with the standard Model 7751, 7752, and 7753 switch/control modules, a wide range of supporting measurements can be made. These supporting measurements simplify creating integrated test solutions for hybrid applications, such as testing complex automotive seating systems, which increasingly combine airbag inflators and seatbelt pre-tensioners, seat heaters, switches, motors, etc.

### Newly Enhanced Memory Pattern Test Sequencer

The memory pattern test sequencer allows the mainframe to store and execute pre-programmed test sequences for increased testing throughput. Test setups can be stored as unique memory locations and either recalled by number as needed or scanned in sequence to maximize the number of tests per unit time without command transfer delays due to communication or controller.

### APPLICATIONS

- Automotive airbag inflator/module electrical functional tests
- Seatbelt pre-tensioner actuator/module functional electrical check
- High speed, parallel soak, dual inflator, or dual test station electrical check
- Pinched wire, high voltage, insulation resistance testing in automotive seats, avionics, etc.
- Multipin connector/harness continuity and leakage resistance measurements
- Multicontact/switch dry circuit continuity and leakage tests
- Automotive power/fuse center continuity and leakage resistance characterization
- PCB/PWB and general purpose short/open circuits testing

1.888.KEITHLEY (U.S. only)

[www.keithley.com](http://www.keithley.com)
**KEITHLEY**

A Greater Measure of Confidence

A Tektronix Company

# 2790

# SourceMeter® Airbag Test System

## Ordering Information

**2790-A 1MΩ single-module system for low and high voltage/resistance applications**

**2790-H Single-module system for low and high voltage/resistance applications**

**2790-HH Two-module system for low and high voltage/resistance applications**

**2790-HL Two-module system for separating high and low voltage/resistance applications**

**2790-L Single-module system for low voltage/resistance-only programmable current applications**

**7702 40-channel Differential Multiplexer**

## Accessories Supplied

Reference and user manuals on CD-ROM, AC line power cord, mini flathead screwdriver.

## ACCESSORIES AVAILABLE

### MODULES

7702	40-channel General Purpose Multiplexer Module
7751	High Voltage Source/Switch Module
7752	Low Voltage, Current-Source-Only Source/Switch Module
7753	1MΩ High Voltage Source/Switch Module (The Model 2790 supports only one Model 7753.)

### COMMUNICATION INTERFACES AND CABLES

7007-1	Shielded IEEE-488 Cable, 1m (3.3 ft)
7007-2	Shielded IEEE-488 Cable, 2m (6.6 ft)
7009-5	Shielded RS-232 Cable
KPCI-488LPA	IEEE-488 Interface/Controller for the PCI Bus
KUSB-488B	IEEE-488 USB-to-GPIB Interface Adapter

### RACK MOUNT KITS

4288-1, -2	Single or Dual Fixed Rack Mount Kit
------------	-------------------------------------

### OTHER

8503	Trigger Link Cable to 2 Male BNC Connector
8681	Miniature 4-Wire RTD, 100Ω

## SERVICES AVAILABLE

2790-3Y-EW	1-year factory warranty extended to 3 years from date of shipment
2790-A-3Y-EW	1-year factory warranty extended to 3 years from date of shipment
2790-L-3Y-EW	1-year factory warranty extended to 3 years from date of shipment
C/2790-3Y-ISO	3 (ISO-17025 accredited) calibrations within 3 years of purchase for Models 2790, 2790-L*
C/2790-A-3Y-ISO	3 (ISO-17025 accredited) calibrations within 3 years of purchase for Model 2790-A*

\*Not available in all countries

## Match the System Configuration to the Application

The Model 2790 is available in a variety of configurations to match specific application requirements:

- The **Model 2790-H** is a single-module system designed for both low current and high voltage ohms (10MΩ to 1GΩ) applications. This “base” system provides all the capabilities needed for electrical testing of either single- or dual-stage inflators in single position test stands (for example, test stands that test only one single- or dual-stage airbag at a time).
- The **Model 2790-A**, which is similar to the Model 2790-H, enables high voltage ohms measurements down to 1MΩ.
- The **Model 2790-HH** is configured for applications that require parallel testing or high voltage “soaking.” Like the Model 2790-H, it is designed for both low current and high voltage ohms applications and can test either single- or dual-stage inflators. However, with two plug-in modules, it also has the capacity to test two inflators at once, maximizing test throughput.
- The **Model 2790-HL** is designed for applications where it is preferable to segregate high voltage sourcing/ohms measurement and low current sourcing/ohms measurement into two separate modules. This design was developed for use in combination testing applications, such as inflator electrical checks of safety steering wheel or seat assemblies that also include switch or other ancillary device tests.
- The **Model 2790-L** is configured for low voltage source/ohms-only measurement applications, such as continuity-only testing of side/seat airbags and seatbelt pre-tensioners or other programmable I-source resistance applications in which high voltage resistance testing is not required but precise control of source current is.
- With the addition of a Model 7702 40-channel differential multiplexer module (part of the Integra family of switch/measure solutions), the **Model 2790-A, -H, or -L + Model 7702** opens the door to higher channel count applications, such as hi-pot/continuity testing of connectors, harnesses, and power distribution devices up to 500V (internally sourced) up to 40 channels.

## Broad Range of Measurement Capabilities

The Model 2790’s built-in DMM can make a wide variety of general purpose measurements:

- DC voltage measurements from 0.1μV to 1000V
- AC voltage measurements from 0.1μV to 750V
- DC current measurements from 10nA to 3A
- AC current measurements from 1μA to 3A
- 2-wire resistance measurements from 100μΩ to 120MΩ
- 4-wire resistance measurements from 100μΩ to 120MΩ
- Frequency measurements from 3Hz to 500kHz
- Period measurements from 333ms to 2μs
- Temperature measurements from -200°C to 630°C (thermistors and 4-wire RTDs)

Additional features of the Model 2790 mainframe include:

- Setup storage—Up to four instrument setups can be saved and recalled.
- Offset-compensated ohms—A two-measurement process for 4-wire ohms to cancel the effects of thermoelectric EMFs. Available for the 100Ω, 1kΩ, and 10kΩ ranges.
- Math—m/X+b, mX+b, percent, and four special math functions provide convenient manipulation of raw readings.
- Relative—Null offsets establish baseline values.
- Ratio and channel average—Ratio and average calculations for two switching module channels (7702).
- Buffer—Store up to 55,000 readings in the internal buffer.
- Limits—Two sets of high and low reading limits to test devices.
- Digital I/O port—Five digital limit test output lines to control external circuitry. An external trigger input can also be accessed at this port.
- Trigger Link—Separate connector with input and output signals.
- Monitor—The Model 2790 can monitor a selected channel. A scan can be triggered to start when the monitor detects that a reading limit has been reached (7702).
- Remote interface—Model 2790 can be controlled using the IEEE-488 interface (GPIB) or the RS-232 interface.

1.888.KEITHLEY (U.S. only)

www.keithley.com

KEITHLEY

A Greater Measure of Confidence

A Tektronix Company

Multichannel resistance measurements for airbag inflator, harness, and connector testing

DIGITAL MULTIMETERS & SYSTEMS

## Example Application – Dual Stage Airbag Inflator Testing—One or Two

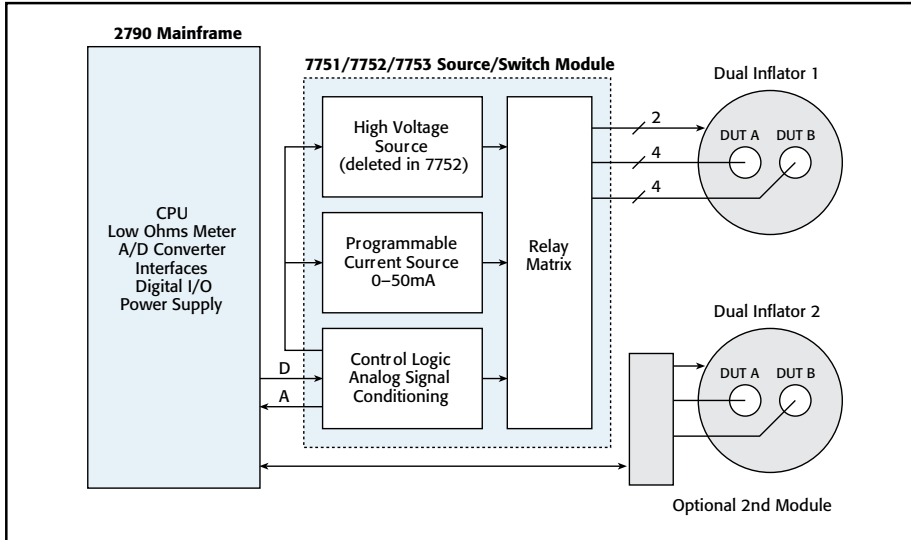

## Example Application – 40-channel Wiring Harness Testing

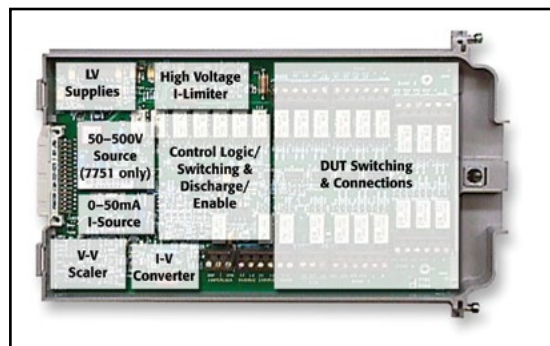
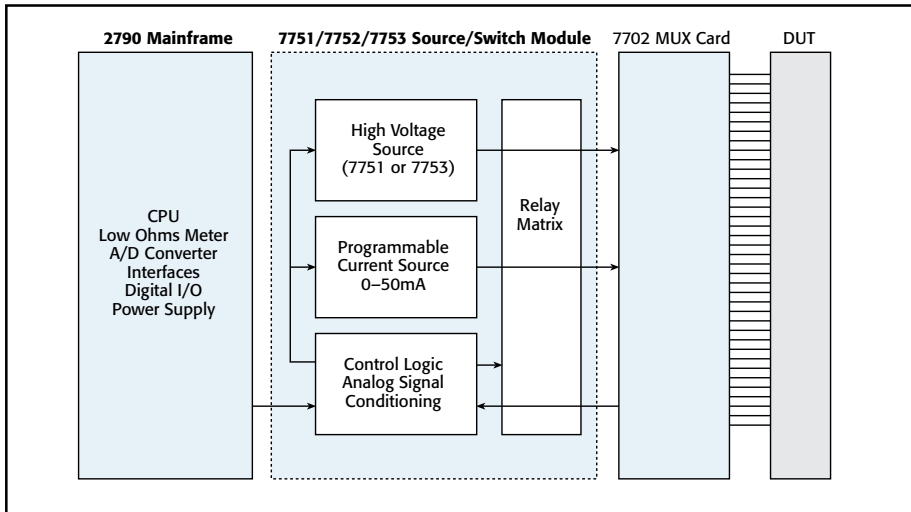

Three source/switch plug-in modules provide the Model 2790 with programmable high voltage and low current sources, connection switching, and signal conditioning circuitry.

## Model 2790 Benefits

- **High functional integration**—Sourcing, measurement, and signal routing functions are tightly integrated in one compact enclosure. This high level of integration helps system integrators save rack space, minimize the time needed for system configuration and maintenance, and improve test throughput without sacrificing system accuracy.
- **Enhanced device protection**—Compared to higher powered alternatives, the Model 2790's inherently lower power sources minimize the possibility of damaging sensitive devices under test through accidental overpowering. Automatic cold switching and active cable discharge circuitry reduce the chances for device damage still further, while the high precision DMM and A/D converter ensure high resolution and measurement accuracy.
- **Reliability**—The design of the Model 2790 is based on a proven Keithley technology platform. With a two-year calibration cycle for the module functions, it requires minimal maintenance over the life of the production test line. Its modular mainframe and plug-ins architecture makes module verification and calibration fast and convenient, simply by exchanging modules.
- **Value**—In addition to being a complete solution for airbag inflator testing and related applications, the Model 2790's fully functional, 6½-digit DMM supports a wide variety of general purpose DC and AC measurements.

## Mainframe Specifications

Refer to the Model 2700 specifications on page 269.

## Key Module Specifications\*

Refer to module specifications on page 273.

## SYSTEM THROUGHPUT

HIGH OHMS: 13 rdgs/s.

LOW OHMS: 9 rdgs/s.

\* The Model 7751, 7752, and 7753 plug-in modules have a two-year calibration interval; mainframe-only functions have a one-year calibration interval (max). System warranty period is one year.

1.888.KEITHLEY (U.S. only)

[www.keithley.com](http://www.keithley.com)



## 7751/7752/7753 SOURCE/SWITCH MODULE SPECIFICATIONS

## 2790 RESISTANCE MODE SPECIFICATIONS WITH CARDS 2, 3

(Module function accuracy specifications are for 2 years, 23°C, ±5°C.)

Source Current	Maximum Resistance	Typical Open Circuit Voltage	Accuracy (4W) ±(%rdg.+ohms)	Temperature Coefficient (0–18°C & 28–40°C) ±(%rdg.+ohms)/°C
50 mA	20	5.5 V	0.09% + 2 m	0.002% + 3 m
20 mA	50	5.5 V	0.11% + 5 m	0.003% + 3 m
10 mA	100	5.5 V	0.16% + 10 m	0.004% + 3 m
<b>(Dry Circuit Ohms 1mA max. with 7751, 7752, or 7753 card)</b>				
1 mA	10	20 mV	1.10% + 50 m	(0.026% + 3 m)/°C

(7751 Only)

Source Voltage	Resistance Range	Maximum Short Circuit Current	Accuracy ±(% rdg.)	Temperature Coefficient (0–18°C & 28–40°C) ±(%rdg.)/°C
500 V	10 M	<1 mA	0.8%	0.03%
500 V	100 M	<1 mA	1.1%	0.05%
500 V	1 G	<1 mA	4.0%	0.12%
50 V	1 M	<1 mA	1.1%	0.04%
50 V	10 M	<1 mA	1.1%	0.06%
50 V	100 M	<1 mA	1.6%	0.13%

(7753 Only)

Source Voltage	Resistance Range	Maximum Short Circuit Current	Accuracy ±(% rdg.)	Temperature Coefficient (0–18°C & 28–40°C) ±(%rdg.)/°C
500 V	1 M	<1 mA	0.8%	0.02%
500 V	10 M	<1 mA	0.9%	0.03%
500 V	100 M	<1 mA	1.3%	0.10%
500 V	1 G	<1 mA	6.7%	0.27%
50 V	0.1 M	<1 mA	1.1%	0.03%
50 V	1 M	<1 mA	1.1%	0.04%
50 V	10 M	<1 mA	1.3%	0.11%
50 V	100 M	<1 mA	4.5%	0.30%

## CURRENT SOURCE OUTPUT

OUTPUT LEVEL: Programmable 0 to 50mA (Ch. 27).

PROGRAMMING RESOLUTION: 10µA.

OUTPUT VOLTAGE: 5.5V ±10% compliance.

ACCURACY: ±(0.06% + 10µA) (2 year specification).

SETTLING TIME: 1ms to 0.1% of final value (typ.).

TEMPERATURE COEFFICIENT (0–18°C &amp; 28–40°C): ±(0.001% + 0.25µA)/°C.

DRY CIRCUIT CLAMP (Ch. 24): 20mV ±10%, I<sub>source</sub> ≤1mA.

## VOLTAGE SOURCE OUTPUT (7751/7753 Only)

OUTPUT LEVEL: Programmable 50V to 500V (Ch. 28).

PROGRAMMING RESOLUTION: 100mV.

OUTPUT CURRENT: (7751) 50µA maximum for rated accuracy, <1mA typical into short circuit.  
(7753) 500µA maximum for rated accuracy, <1mA typical into short circuit.

ACCURACY: ±(0.5% + 0.13V) (2 year specification).

SETTLING TIME: Rise Time: 50V to 500V step, 0.1% of final value, 250ms max.  
Fall Time: 500V to 50V step, 0.1% of final value, 1000ms max.

TEMPERATURE COEFFICIENT (0–18°C &amp; 28–40°C): ±(0.001% + 0.005V)/°C

SAFETY LIMIT: Current limited maximum current of 1mA.

CABLE DISCHARGE (Ch. 20): 100kΩ shunt.

MAXIMUM CAPACITANCE: 1nF.

## CURRENT MEASURE INPUT (7751/7753 Only)

RANGE: 7751: 0–50µA. 7753: 0–500µA.

ACCURACY: 7751: ±(0.5% of reading + 6nA) (2 year specification).

7753: ±(0.5% of reading + 60nA) (2 year specification).

TEMPERATURE COEFFICIENT (0–18°C &amp; 28–40°C): ±(0.02%+0.5nA)/°C.

VOLTAGE BURDEN: &lt;1mV.

## SWITCHING CAPABILITIES (Bank 1–Bank 4)

4 CHANNELS: 1 Form A switch.

8 CHANNELS: Four 4-pole or eight 2-pole signals into DMM or I/V converter.

CONTACT CHECK: 4-wire contact check through internal DMM.

RELAY TYPE: Latching electromechanical.

ACTUATION TIME: &lt;3ms.

CONTACT LIFE (typical): >10<sup>6</sup> operations at maximum source level.  
>10<sup>8</sup> operations cold switching.

CONTACT RESISTANCE: &lt;1Ω at end of contact life.

CONTACT POTENTIAL: &lt;±2µV typical per contact pair, ±3µV max.

CONNECTOR TYPE: Plugable screw terminal, #22 AWG wire size.

ISOLATION BETWEEN ANY TWO TERMINALS<sup>1</sup>: >1GΩ, <100pF.ISOLATION BETWEEN TERMINALS AND EARTH<sup>1</sup>: >1GΩ, <200pF.ISOLATION BETWEEN CHANNEL GROUPS<sup>1</sup>: >500GΩ, <100pF.

EXTERNAL COMMON MODE VOLTAGE: 42V between any terminal and chassis. (Connect no external sources.)

## 7751, 7752, OR 7753 MODULE NOTES

- 1 Isolation for channels 1–12, only one channel closed at a time, or all channels open.
- 2 See User's Manual for ohm specifications at sources other than those specified.
- 3 All specifications valid for 1 NPLC ADC aperture setting.

## SYSTEM THROUGHPUT

(Connect, source, measure, calculate)

0.01 NPLC, FILTER OFF, OVER GPIB BUS: High Ohms (Source V): 13 rdgs/s<sup>1</sup>.  
Low Ohms (Source I): 9 rdgs/s.1 NPLC, FILTER ON, OVER GPIB BUS: High Ohms (Source V): 11 rdgs/s<sup>1</sup>.  
Low Ohms (Source I): 7 rdgs/s.

## SYSTEM THROUGHPUT NOTES

1. Reset upon fixed V<sub>source</sub> level, no settling time.

## BASIC AIRBAG TEST SEQUENCE THROUGHPUT

(Body Pin + Bridgewire Continuity = Shorting Clip + Insulation Resistance)

0.55/0.97 seconds for single/dual stage DUT w/scan (sequential) memory patterns.

1.0/2.0 seconds for single/dual stage DUT w/recall (random access) memory patterns.

1.1/1.7 seconds for single/dual stage DUT discrete control w/GPIB I/O.

(Sequence times are totals @ 1 line cycle integration for rated accuracy.)



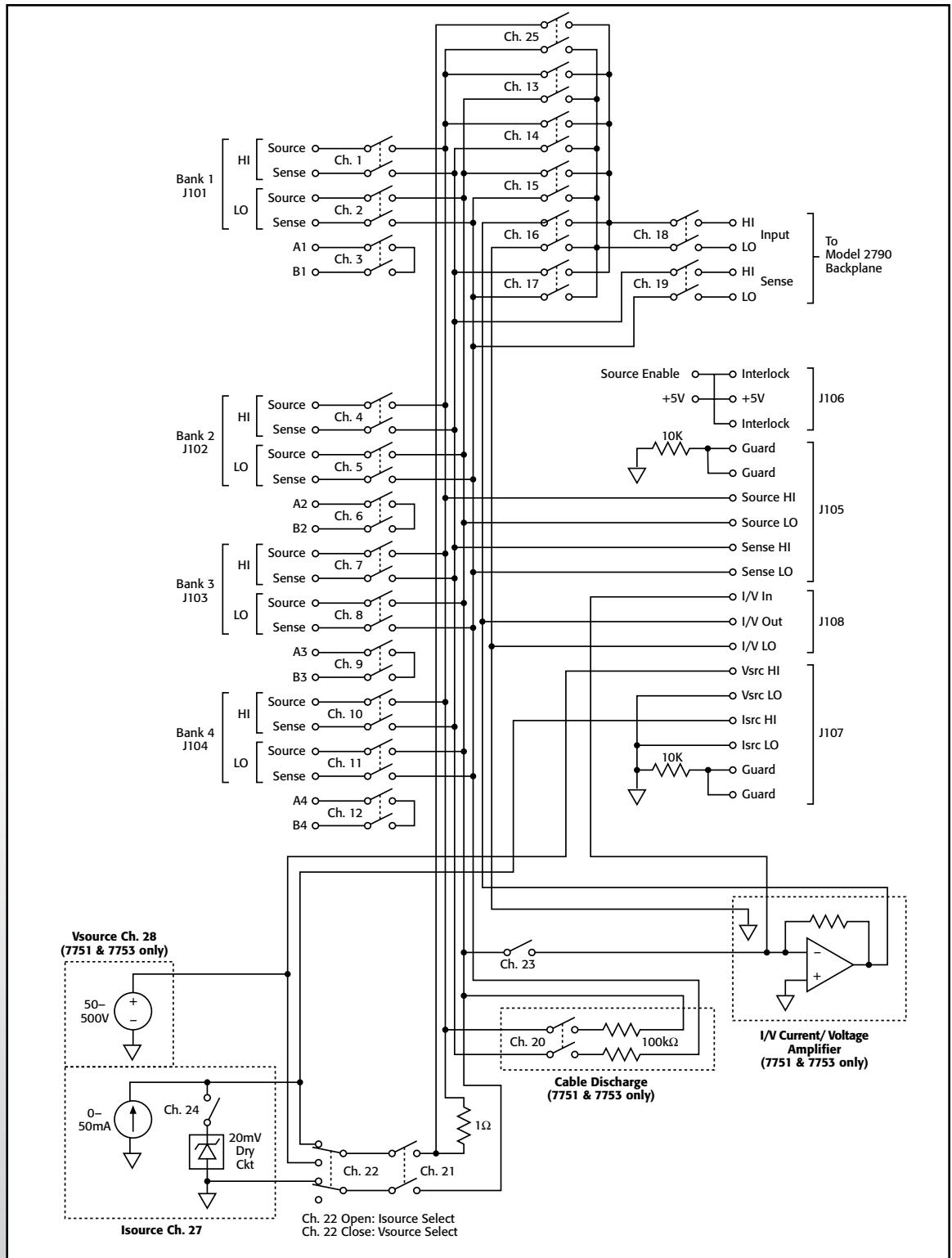

**7751  
7752  
7753**

**High Voltage Source/Switch Module  
Low Voltage, Current-Source-Only Source/Switch Module  
1MΩ High Voltage Source/Switch Module**



- Sourcing and switching for airbag inflator testing with the Model 2790
- Programmable 0–50mA current source
- Programmable 50–500V voltage source (7751 and 7753)
- Built-in I/V converter (7751 and 7753)
- Low energy sources, a hardware source interlock, and programmable shunts help prevent accidental detonations

**Ordering Information**

- 7751** High Voltage Source/Switch Module
- 7752** Low Voltage, Current-Source-Only Source/Switch Module
- 7753** 1MΩ High Voltage Source/Switch Module

**SERVICES AVAILABLE**

7751-3Y-EW	1-year factory warranty extended to 3 years from date of shipment
7752-3Y-EW	1-year factory warranty extended to 3 years from date of shipment
7753-3Y-EW	1-year factory warranty extended to 3 years from date of shipment

The Model 7751, 7752, and 7753 Source/Switch Modules are designed exclusively for use in the Model 2790 SourceMeter Switch System for electrical checks of airbag inflators and a variety of other automotive electrical test applications. These modules provide the programmable high voltage and low current sourcing, plus the multichannel switching support required to measure insulation resistance and conductor continuity in these applications.

The Model 7751 and 7753 modules include programmable DC voltage (50–500V) and current (0–50mA) sources, as well as relay switching. A built-in current-to-voltage converter on these modules is used with the voltage source to measure the insulation resistance. They can also be used to measure currents from 0–50μA. The constant current source is useful for measuring the resistance of bridgewires and shunt bars. Four banks of two-pole relays provide a sufficient number of terminals to connect two single inflator units or one dual inflator unit to the Model 2790 mainframe for testing. The mainframe will accommodate two plug-in modules, so a single Model 2790 system can be connected to two test stands and be used to test two dual inflator airbag modules. Parallel testing in the form of “voltage soak with one card, measure with the other” is possible for both single and double test stand configurations. The switch matrix of the Model 7751 and 7753 simplifies implementing contact verification tests and allows the Model 2790 to verify test voltages and currents for increased measurement reliability.

The Model 7752 module is identical to the Model 7751, except that it does not include the high voltage source and current-to-voltage converter. The Model 7753 is identical to the Model 7751 except that the lowest high ohms measurement for the Model 7753 is 1MΩ and for the Model 7751 is 10MΩ.

Safety related design features that provide added protection against accidental detonation include low energy sources, a hardware source interlock, and programmable shunts that can be used in conjunction with an inflator’s shunt bar.

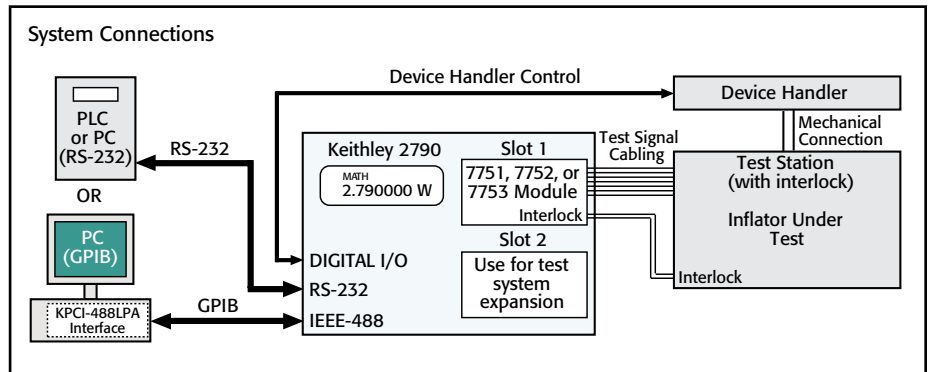

1.888.KEITHLEY (U.S. only)

[www.keithley.com](http://www.keithley.com)

A Greater Measure of Confidence

**KEITHLEY**

A Tektronix Company

Source/switch modules for airbag inflator testing with the Model 2790

DIGITAL MULTIMETERS & SYSTEMS

1.888.KEITHLEY (U.S. only)

[www.keithley.com](http://www.keithley.com)

A Greater Measure of Confidence

**KEITHLEY**  
A Tektronix Company