

DMM6500 6½-Digit Bench/System Digital Multimeter

Datasheet



The DMM6500 is a modern Bench/System DMM delivering more measurement functionality, best-in-class measurement insight, and a price that will not break your budget. The most recognizable feature of the DMM6500 is the large 5-inch capacitive touch display that makes it easy to observe, interact with, and explore measurements with “pinch and zoom” simplicity. Beyond its display technology, the DMM 6500 superior analog measurement performance delivers 25 PPM basic DCV accuracy for one year and 30 PPM for two years, potentially allowing you to extend your calibration cycles.

The DMM6500 is equipped with all the measurement functions you would expect in a bench multimeter, so there’s no need to buy additional measurement capabilities. Its 15 measurement functions, including capacitance, temperature (RTD, thermistor, and thermocouple), diode test with variable current sources, and up to 1 MS/sec digitizing are now included.

The digitizing function can be used for voltage or current and is especially useful in capturing transient anomalies or to help profile power events such as the operating states of today’s battery operated devices. Current and voltage can be digitized with a programmable 1 MS/sec 16-bit digitizer, making it possible to acquire waveforms without the need for a separate instrument.

Key Features

- 15 measurement functions including capacitance, temperature, and digitizing
- Expanded ranges including 10 μ A to 10 A and 1 Ω to 100 M Ω
- Large 5-inch (12.7 cm) multi-touch capacitive touchscreen with graphical display
- Large internal memory; store up to 7 million readings
- Multiple language modes: SCPI, TSP® scripting, Keithley 2000 SCPI emulation, Keysight 34401A SCPI emulation
- Two-year specifications allow for longer calibration cycles
- Standard USB and LXI/Ethernet communication interfaces
- Optional user-installable communication interfaces including: GPIB, TSP-Link®, and RS-232
- Capture voltage or current transients with 1 MS/sec digitizer
- USB host port for storing readings, instrument configurations, and screen images
- Three-year warranty

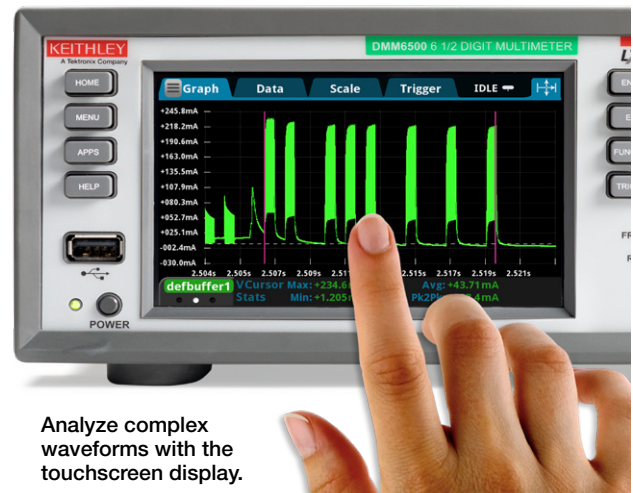

Analyze complex waveforms with the touchscreen display.

Capture and Analyze DC Voltage or Current Transitions

Power analysis is becoming more important in today's electronic designs. Designers must now consider more efficient components and complex system design typically requiring multiple power states. The DMM6500 has the tools you need to help design and troubleshoot these complex systems. Eight different current ranges from 10 amps down to 10 micro-amps gives you the dynamic range to measure your power states. In addition a built-in 1 MS/sec digitizing function can help capture transient events, allowing you to see and analyze transitions as they occur.

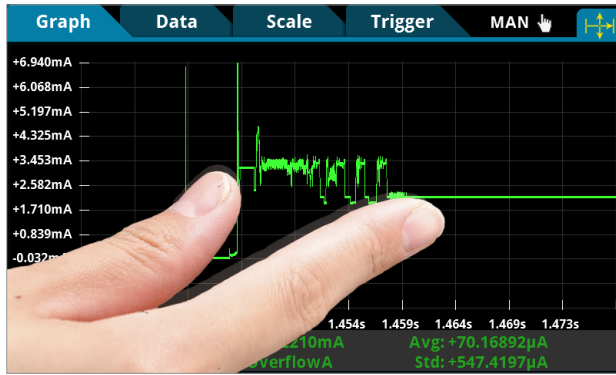

Pinch and zoom simplicity.

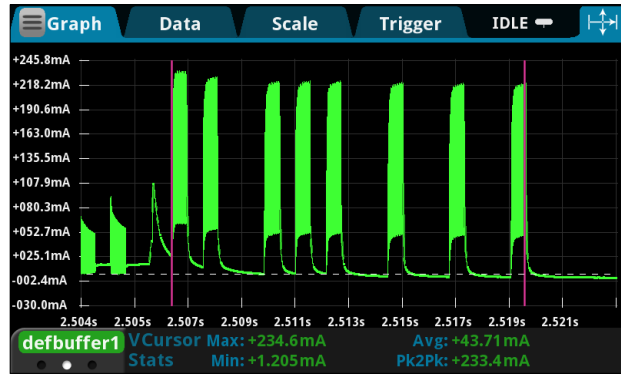

Visualize and analyze waveforms.

DMM6500 Measurement Capabilities

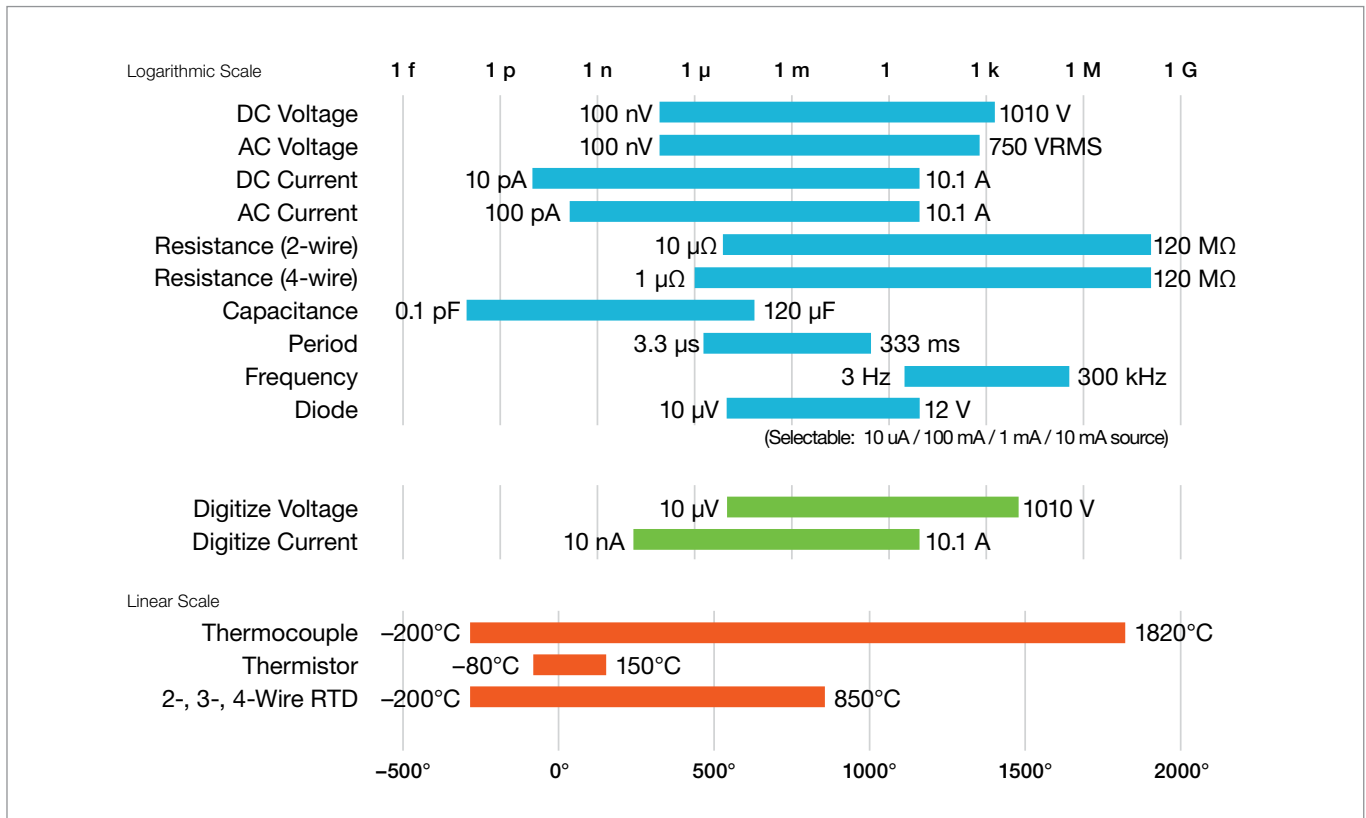

DMM6500 15 measurement functions and ranges.

DRAFT CONTENT

DMM6500 Touchscreen Display Front Panel

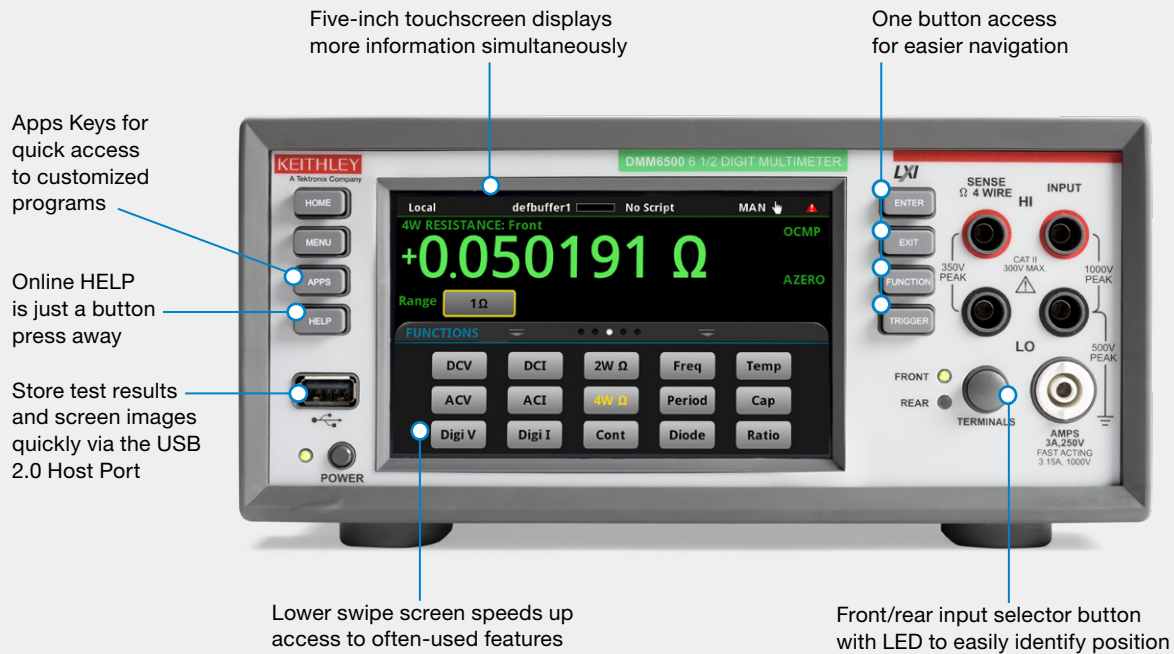

DMM6500 Rear Panel

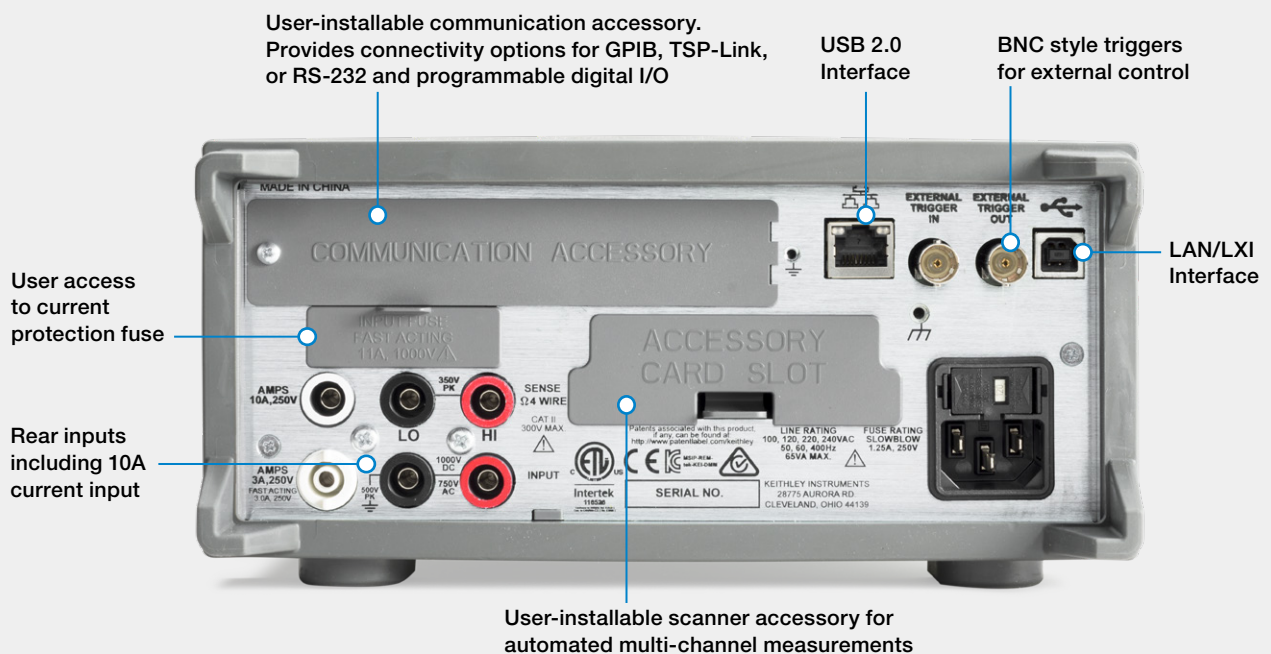

Multi-channel/Scanning Applications

When characterizing or profiling your design it is often critical to make a series of measurements. In these applications the need for automated multi-channel measurements is advantageous. The DMM6500 is equipped with a scanner card slot allowing up to 10 channels of switching, giving you the capability to make automated multi-channel measurements. Plugging in the 2000-SCAN card gives users up to 10 channels of 2-pole measurements or 5 channels of 4-pole measurements. Functions can be programmed on a per-channel basis if supported by the switch topology.

2000-SCAN 10-Channel Multiplexer.

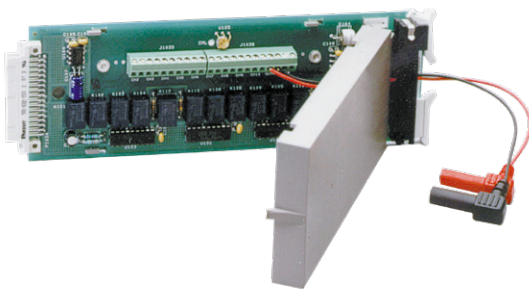

Application Programs

The DMM6500 is factory installed with two application programs to help you get more out of your instrument. These application programs appear when the instrument is used in the TSP or SCPI communication language mode. These examples highlight the unique ability of the DMM6500 to run specialized applications which customize the user interface. This can significantly change the way information is displayed or even automated in performing an application

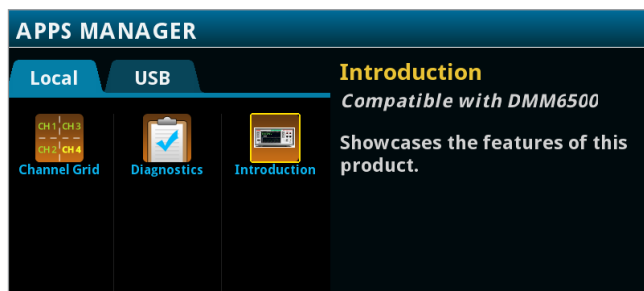

Menu of application programs that can customize the display or perform special functions.

Temperature Measurement Applications

Temperature is one of the most measured signal types in the world, and the DMM6500 has many options to help you make this measurement. Besides RTD, thermistor, and thermocouple functions, you can equip your DMM with a nine-channel scanner card with built-in CJC for automated thermocouple temperature scanning. This feature is very useful when your design requires thermal profiling, especially when enclosed in a temperature chamber.

2001-TCSCAN 9-Channel Thermocouple Multiplexer and DMM6500 rear panel.

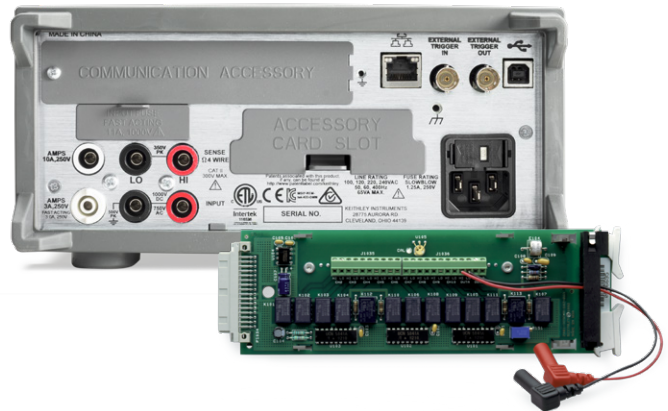

Ready to Use Instrument Drivers Simplify Programming

Prefer to create your own customized application software? Native National Instruments Labview®, IVI-C, and IVI-COM drivers are available for downloading to simplify the programming process. For the Labview® driver visit www.ni.com; for IVI drivers visit www.tek.com.

System Integration and Programming

Users have maximum programming flexibility with the DMM6500. In addition to traditional SCPI programming (default), the unit can also be configured for SCPI emulation for the Keithley 2000 or the Keysight 34401A. Additionally, Keithley’s powerful Test Script Processor (TSP®) programming is another option that allows unique single- or multi-instrument testing applications where speed is critical.

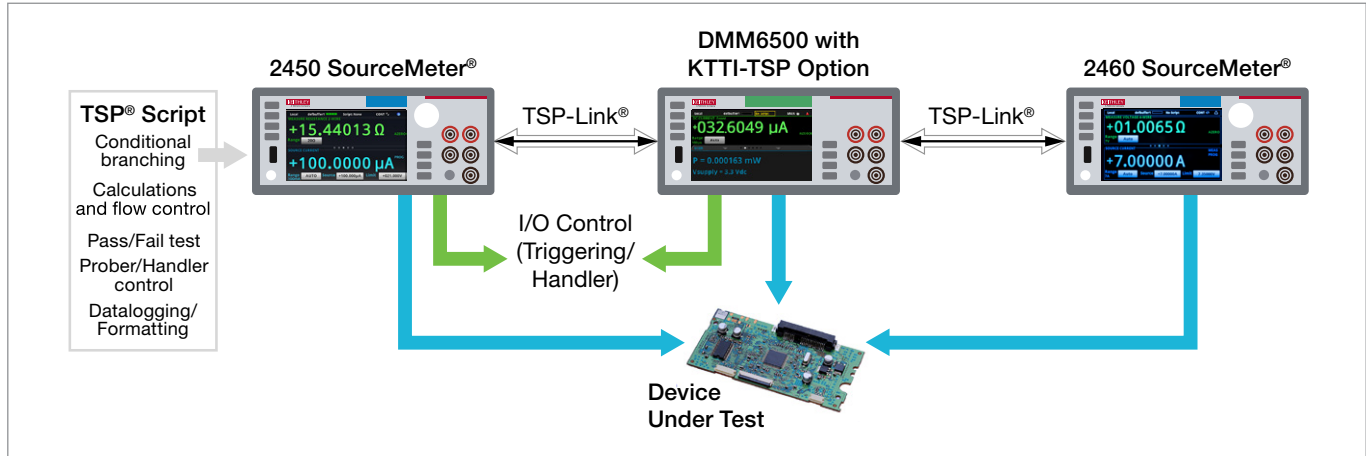

TSP System using TSP-Link for instrumentation connections.

TSP® scripting allows running powerful test scripts directly on the instrument, without the need for an external PC controller. These test scripts are complete test programs based on an easy-to-use yet highly efficient and compact scripting language, LUA (www.lua.org). Scripts are a collection of instrument control commands and/or program statements. Program

```

1 -- Define functions...
2 function meas4WRes(nplcVal)
3   --Set measure function to 4-wire Res
4   dmm.measure.func = dmm.FUNC_4W_RESISTANCE
5
6   --Enable autorange.
7   dmm.measure.autorange = dmm.ON
8
9   --Enable autozero.
10  dmm.measure.autozero.enable = dmm.ON
11
12  --Enable OCOMP
13  dmm.measure.offsetcompensation.enable = dmm.ON
14
15  --Set the number of power line cycles
16  dmm.measure.nplc = nplcVal
17
18  --Read the resistance value.
19  return dmm.measure.read()
20 end
21
22 -- Run main code...
23 -- Reset the Model DMM6500
24 reset()
25
26 -- Execute a 4W measurement
27 print(meas4WRes(1.0))
    
```

TSP Scripting example showing 4-wire resistance.

statements control script execution and provide facilities such as variables, functions, branching, and loop control. This allows you to create powerful measurement applications without an integrated development environment (IDE). Test scripts can contain any sequence of routines that are executable by conventional programming languages (including decision-making algorithms), so the instrument can manage every facet of the test without the need to communicate with a PC for decision making. This eliminates delays due to GPIB, Ethernet, or USB traffic congestion and greatly improves test times.

TSP® technology also offers mainframe-less channel expansion. The KTTI-TSP is a user installable accessory card offering connectivity to TSP-Link® technology. This channel expansion bus allows connecting multiple DMM6500's or other TSP® enabled instruments together to form a tightly synchronized instrument system. Connection is provided with simple low cost Category 5 Ethernet cabling. The system is organized in a master-subordinate configuration, essentially allowing the connected instruments to act as one. Other Keithley TSP®-enabled instruments include the 2450 and 2460 Graphical SourceMeter® SMU Instruments, Series 2600B SourceMeter® SMU Instruments, and the Series 3700A Switch/Multimeter Measurement systems. TSP-Link® technology supports up to 32 units, so it's easy to scale a system to fit the requirements of an application.

Instrument PC Control Software

Prefer to use a PC to control your DMM? The KickStart 2.0 PC control software is designed to get you up and running to configure, measure, and analyze your data quickly.

KickStart 2.0 allows you to configure tests and collect data from multiple DMMs. It captures millions of readings directly to PC disk media so that the data is safely archived. Save your test configurations so that you can quickly replicate previous tests and create a set of tests for a particular device or compliance standard. KickStart 2.0 also includes comparison tools to allow you to plot and overlay data from the run history of each test.

Additionally, you can tailor both the presentation and the export of data in the software for your needs

- View data of interest in the graph and table in easy-to-read formats.
- Obtain a quick statistical overview of data based on data shown in sheet visible in the table.
- Mark data on graph to highlight points of interest
- Export the data at any time during the test to share test updates with your colleagues.

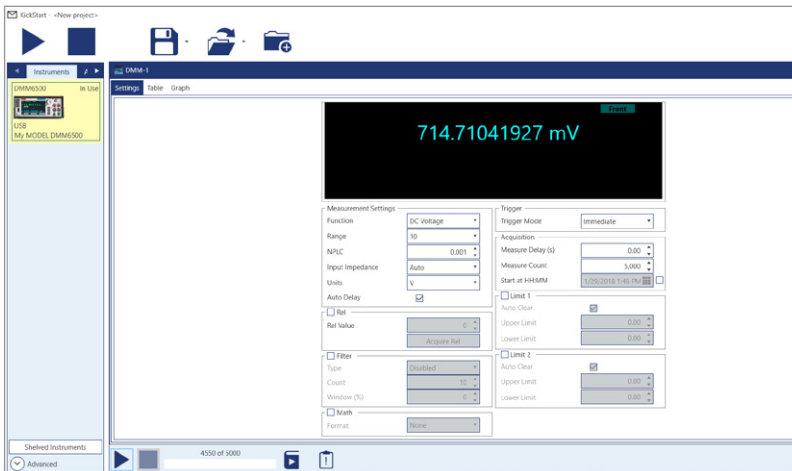

Kickstart 2.0 allows you to perform and setup a test quickly and easily using a single point-and-click setup screen.

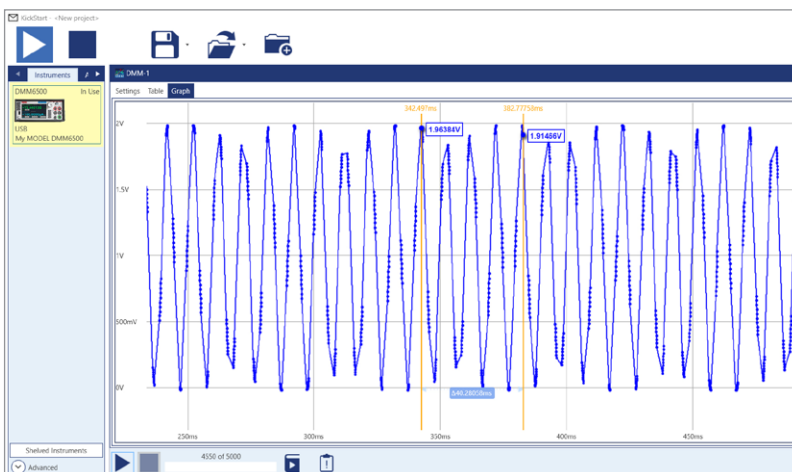

Kickstart 2.0 allows you to display data graphical format, OR tabular format, OR both.

Ordering Information

DMM6500	6-1/2 Digit Bench/System Digital Multimeter
---------	---

Supplied Accessories

Power cord, 1 m USB cable (type A to type B), calibration certificate and 1757 Standard Test Lead Kit

Available Software

Software IVI/VISA drivers for Microsoft® Visual Basic®, Visual C/C++®, National Instruments (NI™) LabVIEW™, NI LabWindows™/CVI, Keithley Test Script Builder and KickStart.
www.tek.com/product-support

Available Services

5-year Extended Warranty, Calibration Services, Calibration Data, ISO 17025 Calibration

Optional Multi-Channel/Scanner Accessories

2001-TCSCAN Card	10 channel 2-pole or 5 channel 4-pole multiplexer
2000-SCAN Card	9 channel 2-pole or 4-channel 4-pole multiplexer with CJC sensor

Limited compatibility with 2001-SCAN and 2000-SCAN-20. See the DMM6500 Firmware Release Notes for additional information.

Optional Interfaces and Programmable Digital I/O

KTTI-RS232	RS-232, 9 pin D-Sub female connector. Standard baud rates from 300 to 115,200 bps are supported.
KTTI-GPIB	GPIB interface with 6 digital I/O ports, IEEE-488.1 compliant. Supports IEEE-488.2 common commands and status model topology
KTTI-TSP	RJ-45 (quantity 2). TSP-Link® expansion interface with 6 digital I/O ports, allows TSP-enabled instruments to trigger and communicate with each other.

Digital I/O For KTTI-RS232, KTTI-GPIB, KTTI-TSP

Connector: 9 pin D-Sub female

5 V Power Supply Pin: Limited to 500 mA >4 V (solid state fuse protected)

Lines: Six input/output, user-defined for control, alarms (limits), or triggering

Input Signal Levels: 0.7 V (maximum logic low), 3.7 V (minimum logic high)

Input Voltage Limits: -0.25 V (absolute minimum), 5.25 V (absolute maximum)

Maximum Source Current: 2.0 mA at >2.7 V (per pin)

Maximum Sink Current: -50 mA at 0.7 V (per pin, solid state fused)

For test leads, probes, and other accessories, please visit www.tek.com.

Contact Information

Australia* 1 800 709 465
Austria 00800 2255 4835
Balkans, Israel, South Africa and other ISE Countries +41 52 675 3777
Belgium* 00800 2255 4835
Brazil +55 (11) 3759 7627
Canada 1 800 833 9200
Central East Europe/Baltics +41 52 675 3777
Central Europe/Greece +41 52 675 3777
Denmark +45 80 88 1401
Finland +41 52 675 3777
France* 00800 2255 4835
Germany* 00800 2255 4835
Hong Kong 400 820 5835
India 000 800 650 1835
Indonesia 007 803 601 5249
Italy 00800 2255 4835
Japan 81 (3) 6714 3086
Luxembourg +41 52 675 3777
Malaysia 1 800 22 55835
Mexico, Central/South America and Caribbean 52 (55) 56 04 50 90
Middle East, Asia, and North Africa +41 52 675 3777
The Netherlands* 00800 2255 4835
New Zealand 0800 800 238
Norway 800 16098
People's Republic of China 400 820 5835
Philippines 1 800 1601 0077
Poland +41 52 675 3777
Portugal 80 08 12370
Republic of Korea +82 2 6917 5000
Russia/CIS +7 (495) 6647564
Singapore 800 6011 473
South Africa +41 52 675 3777
Spain* 00800 2255 4835
Sweden* 00800 2255 4835
Switzerland* 00800 2255 4835
Taiwan 886 (2) 2656 6688
Thailand 1 800 011 931
United Kingdom/Ireland* 00800 2255 4835
USA 1 800 833 9200
Vietnam 12060128

* European toll-free number.

If not accessible, call: +41 52 675 3777

Rev. 090617



Find more valuable resources at TEK.COM

Copyright © Tektronix. All rights reserved. Tektronix products are covered by U.S. and foreign patents, issued and pending. Information in this publication supersedes that in all previously published material. Specification and price change privileges reserved. TEKTRONIX and TEK are registered trademarks of Tektronix, Inc. All other trade names referenced are the service marks, trademarks or registered trademarks of their respective companies.

020218 AH 1KW-61315-0

