

**KEITHLEY**

# KPCMCIA-PIO24 24-Channel Digital Input/Output

Type II PCMCIA Card  
User's Manual

A GREATER MEASURE OF CONFIDENCE

# WARRANTY

## Hardware

Keithley Instruments, Inc. warrants that, for a period of one (1) year from the date of shipment (3 years for Models 2000, 2001, 2002, 2010 and 2700), the Keithley Hardware product will be free from defects in materials or workmanship. This warranty will be honored provided the defect has not been caused by use of the Keithley Hardware not in accordance with the instructions for the product. This warranty shall be null and void upon: (1) any modification of Keithley Hardware that is made by other than Keithley and not approved in writing by Keithley or (2) operation of the Keithley Hardware outside of the environmental specifications therefore.

Upon receiving notification of a defect in the Keithley Hardware during the warranty period, Keithley will, at its option, either repair or replace such Keithley Hardware. During the first ninety days of the warranty period, Keithley will, at its option, supply the necessary on site labor to return the product to the condition prior to the notification of a defect. Failure to notify Keithley of a defect during the warranty shall relieve Keithley of its obligations and liabilities under this warranty.

## Other Hardware

The portion of the product that is not manufactured by Keithley (Other Hardware) shall not be covered by this warranty, and Keithley shall have no duty of obligation to enforce any manufacturers' warranties on behalf of the customer. On those other manufacturers' products that Keithley purchases for resale, Keithley shall have no duty of obligation to enforce any manufacturers' warranties on behalf of the customer.

## Software

Keithley warrants that for a period of one (1) year from date of shipment, the Keithley produced portion of the software or firmware (Keithley Software) will conform in all material respects with the published specifications provided such Keithley Software is used on the product for which it is intended and otherwise in accordance with the instructions therefore. Keithley does not warrant that operation of the Keithley Software will be uninterrupted or error-free and/or that the Keithley Software will be adequate for the customer's intended application and/or use. This warranty shall be null and void upon any modification of the Keithley Software that is made by other than Keithley and not approved in writing by Keithley.

If Keithley receives notification of a Keithley Software nonconformity that is covered by this warranty during the warranty period, Keithley will review the conditions described in such notice. Such notice must state the published specification(s) to which the Keithley Software fails to conform and the manner in which the Keithley Software fails to conform to such published specification(s) with sufficient specificity to permit Keithley to correct such nonconformity. If Keithley determines that the Keithley Software does not conform with the published specifications, Keithley will, at its option, provide either the programming services necessary to correct such nonconformity or develop a program change to bypass such nonconformity in the Keithley Software. Failure to notify Keithley of a nonconformity during the warranty shall relieve Keithley of its obligations and liabilities under this warranty.

## Other Software

OEM software that is not produced by Keithley (Other Software) shall not be covered by this warranty, and Keithley shall have no duty or obligation to enforce any OEM's warranties on behalf of the customer.

## Other Items

Keithley warrants the following items for 90 days from the date of shipment: probes, cables, rechargeable batteries, diskettes, and documentation.

## Items not Covered under Warranty

This warranty does not apply to fuses, non-rechargeable batteries, damage from battery leakage, or problems arising from normal wear or failure to follow instructions.

## Limitation of Warranty

This warranty does not apply to defects resulting from product modification made by Purchaser without Keithley's express written consent, or by misuse of any product or part.

## Disclaimer of Warranties

EXCEPT FOR THE EXPRESS WARRANTIES ABOVE KEITHLEY DISCLAIMS ALL OTHER WARRANTIES, EXPRESS OR IMPLIED, INCLUDING WITHOUT LIMITATION, ALL IMPLIED WARRANTIES OF MERCHANTABILITY AND FITNESS FOR A PARTICULAR PURPOSE. KEITHLEY DISCLAIMS ALL WARRANTIES WITH RESPECT TO THE OTHER HARDWARE AND OTHER SOFTWARE.

## Limitation of Liability

KEITHLEY INSTRUMENTS SHALL IN NO EVENT, REGARDLESS OF CAUSE, ASSUME RESPONSIBILITY FOR OR BE LIABLE FOR: (1) ECONOMICAL, INCIDENTAL, CONSEQUENTIAL, INDIRECT, SPECIAL, PUNITIVE OR EXEMPLARY DAMAGES, WHETHER CLAIMED UNDER CONTRACT, TORT OR ANY OTHER LEGAL THEORY, (2) LOSS OF OR DAMAGE TO THE CUSTOMER'S DATA OR PROGRAMMING, OR (3) PENALTIES OR PENALTY CLAUSES OF ANY DESCRIPTION OR INDEMNIFICATION OF THE CUSTOMER OR OTHERS FOR COSTS, DAMAGES, OR EXPENSES RELATED TO THE GOODS OR SERVICES PROVIDED UNDER THIS WARRANTY.



Keithley Instruments, Inc.

28775 Aurora Road • Cleveland, Ohio 44139 • 440-248-0400 • Fax: 440-248-6168

1-888-KEITHLEY (534-8453) • [www.keithley.com](http://www.keithley.com)

Sales Offices: BELGIUM:

Bergensesteenweg 709 • B-1600 Sint-Pieters-Leeuw • 02-363 00 40 • Fax: 02/363 00 64

CHINA:

Yuan Chen Xin Building, Room 705 • 12 Yumin Road, Dewai, Madian • Beijing 100029 • 8610-6202-2886 • Fax: 8610-6202-2892

FINLAND:

Tietäjäsentie 2 • 02130 Espoo • Phone: 09-54 75 08 10 • Fax: 09-25 10 51 00

FRANCE:

3, allée des Garays • 91127 Palaiseau Cédex • 01-64 53 20 20 • Fax: 01-60 11 77 26

GERMANY:

Landsberger Strasse 65 • 82110 Germering • 089/84 93 07-40 • Fax: 089/84 93 07-34

GREAT BRITAIN:

Unit 2 Commerce Park, Brunel Road • Theale • Berkshire RG7 4AB • 0118 929 7500 • Fax: 0118 929 7519

INDIA:

Flat 2B, Willocrissa • 14, Rest House Crescent • Bangalore 560 001 • 91-80-509-1320/21 • Fax: 91-80-509-1322

ITALY:

Viale San Gimignano, 38 • 20146 Milano • 02-48 39 16 01 • Fax: 02-48 30 22 74

JAPAN:

New Pier Takeshiba North Tower 13F • 11-1, Kaigan 1-chome • Minato-ku, Tokyo 105-0022 • 81-3-5733-7555 • Fax: 81-3-5733-7556

KOREA:

2FL., URI Building • 2-14 Yangjae-Dong • Seocho-Gu, Seoul 137-888 • 82-2-574-7778 • Fax: 82-2-574-7838

NETHERLANDS:

Postbus 559 • 4200 AN Gorinchem • 0183-635333 • Fax: 0183-630821

SWEDEN:

c/o Regus Business Centre • Frosundaviks Allé 15, 4tr • 169 70 Solna • 08-509 04 679 • Fax: 08-655 26 10

SWITZERLAND:

Kriesbachstrasse 4 • 8600 Dübendorf • 01-821 94 44 • Fax: 01-820 30 81

TAIWAN:

1FL., 85 Po Ai Street • Hsinchu, Taiwan, R.O.C. • 886-3-572-9077 • Fax: 886-3-572-9031

KPCMCIA-PIO24  
24-Channel Digital Input/Output  
Type II PCMCIA Card  
User's Manual

# Manual Print History

The print history shown below lists the printing dates of all Revisions and Addenda created for this manual. The Revision Level letter increases alphabetically as the manual undergoes subsequent updates. Addenda, which are released between Revisions, contain important change information that the user should incorporate immediately into the manual. Addenda are numbered sequentially. When a new Revision is created, all Addenda associated with the previous Revision of the manual are incorporated into the new Revision of the manual. Each new Revision includes a revised copy of this print history page.

Revision A (Document Number 98930) .....	July 1997
Revision B (Document Number 98930) .....	December 1997
Revision C (Document Number 98930) .....	September 1999
Revision D (Document Number 98930) .....	August 2002

The following safety precautions should be observed before using this product and any associated instrumentation. Although some instruments and accessories would normally be used with non-hazardous voltages, there are situations where hazardous conditions may be present.

This product is intended for use by qualified personnel who recognize shock hazards and are familiar with the safety precautions required to avoid possible injury. Read and follow all installation, operation, and maintenance information carefully before using the product. Refer to the manual for complete product specifications.

If the product is used in a manner not specified, the protection provided by the product may be impaired.

The types of product users are:

**Responsible body** is the individual or group responsible for the use and maintenance of equipment, for ensuring that the equipment is operated within its specifications and operating limits, and for ensuring that operators are adequately trained.

**Operators** use the product for its intended function. They must be trained in electrical safety procedures and proper use of the instrument. They must be protected from electric shock and contact with hazardous live circuits.

**Maintenance personnel** perform routine procedures on the product to keep it operating properly, for example, setting the line voltage or replacing consumable materials. Maintenance procedures are described in the manual. The procedures explicitly state if the operator may perform them. Otherwise, they should be performed only by service personnel.

**Service personnel** are trained to work on live circuits, and perform safe installations and repairs of products. Only properly trained service personnel may perform installation and service procedures.

Keithley products are designed for use with electrical signals that are rated Installation Category I and Installation Category II, as described in the International Electrotechnical Commission (IEC) Standard IEC 60664. Most measurement, control, and data I/O signals are Installation Category I and must not be directly connected to mains voltage or to voltage sources with high transient over-voltages. Installation Category II connections require protection for high transient over-voltages often associated with local AC mains connections. Assume all measurement, control, and data I/O connections are for connection to Category I sources unless otherwise marked or described in the Manual.

Exercise extreme caution when a shock hazard is present. Lethal voltage may be present on cable connector jacks or test fixtures. The American National Standards Institute (ANSI) states that a shock hazard exists when voltage levels greater than 30V RMS, 42.4V peak, or 60VDC are present. **A good safety practice is to expect that hazardous voltage is present in any unknown circuit before measuring.**

Operators of this product must be protected from electric shock at all times. The responsible body must ensure that operators are prevented access and/or insulated from every connection point. In some cases, connections must be exposed to potential human contact. Product operators in these circumstances must be trained to protect themselves from the risk of electric shock. If the circuit is capable of operating at or above 1000 volts, **no conductive part of the circuit may be exposed.**

Do not connect switching cards directly to unlimited power circuits. They are intended to be used with impedance limited sources. NEVER connect switching cards directly to AC mains. When connecting sources to switching cards, install protective devices to limit fault current and voltage to the card.

Before operating an instrument, make sure the line cord is connected to a properly grounded power receptacle. Inspect the connecting cables, test leads, and jumpers for possible wear, cracks, or breaks before each use.

When installing equipment where access to the main power cord is restricted, such as rack mounting, a separate main input power disconnect device must be provided, in close proximity to the equipment and within easy reach of the operator.

For maximum safety, do not touch the product, test cables, or any other instruments while power is applied to the circuit under test. ALWAYS remove power from the entire test system and discharge any capacitors before: connecting or disconnecting cables or jumpers, installing or removing switching cards, or making internal changes, such as installing or removing jumpers.

Do not touch any object that could provide a current path to the common side of the circuit under test or power line (earth) ground. Always make measurements with dry hands while standing on a dry, insulated surface capable of withstanding the voltage being measured.



The instrument and accessories must be used in accordance with its specifications and operating instructions or the safety of the equipment may be impaired.

Do not exceed the maximum signal levels of the instruments and accessories, as defined in the specifications and operating information, and as shown on the instrument or test fixture panels, or switching card.

When fuses are used in a product, replace with same type and rating for continued protection against fire hazard.

Chassis connections must only be used as shield connections for measuring circuits, NOT as safety earth ground connections.

If you are using a test fixture, keep the lid closed while power is applied to the device under test. Safe operation requires the use of a lid interlock.

If  or  is present, connect it to safety earth ground using the wire recommended in the user documentation.

The  symbol on an instrument indicates that the user should refer to the operating instructions located in the manual.

The  symbol on an instrument shows that it can source or measure 1000 volts or more, including the combined effect of normal and common mode voltages. Use standard safety precautions to avoid personal contact with these voltages.

The **WARNING** heading in a manual explains dangers that might result in personal injury or death. Always read the associated information very carefully before performing the indicated procedure.

The **CAUTION** heading in a manual explains hazards that could damage the instrument. Such damage may invalidate the warranty.

Instrumentation and accessories shall not be connected to humans.

Before performing any maintenance, disconnect the line cord and all test cables.

To maintain protection from electric shock and fire, replacement components in mains circuits, including the power transformer, test leads, and input jacks, must be purchased from Keithley Instruments. Standard fuses, with applicable national safety approvals, may be used if the rating and type are the same. Other components that are not safety related may be purchased from other suppliers as long as they are equivalent to the original component. (Note that selected parts should be purchased only through Keithley Instruments to maintain accuracy and functionality of the product.) If you are unsure about the applicability of a replacement component, call a Keithley Instruments office for information.

To clean an instrument, use a damp cloth or mild, water based cleaner. Clean the exterior of the instrument only. Do not apply cleaner directly to the instrument or allow liquids to enter or spill on the instrument. Products that consist of a circuit board with no case or chassis (e.g., data acquisition board for installation into a computer) should never require cleaning if handled according to instructions. If the board becomes contaminated and operation is affected, the board should be returned to the factory for proper cleaning/servicing.

# Table of Contents

---

## 1 Introduction

Features .....	1-2
System configuration .....	1-2
Technical support .....	1-3

## 2 Installation

Hardware setup .....	2-2
Software setup .....	2-2

## 3 Theory of Operation

I/O port description .....	3-2
Port C interrupts description .....	3-2
External interrupt description .....	3-3
Digital input/output .....	3-3

## 4 Register Descriptions

Introduction .....	4-2
Data port A control register (base + 0) .....	4-2
Data port B control register (base + 1) .....	4-3
Data port C control register (base + 2) .....	4-3
Port C interrupt enable register (base + 5) .....	4-4
Interrupt mode control register (base + 6) .....	4-5
Interrupt status register (read only, base + 7) .....	4-6
Interrupt acknowledge register (write only, base + 7) .....	4-6
Summary of interrupt source options .....	4-7
Summary of input/output options .....	4-7
Programming example .....	4-8

## **5 External Connections**

PCMCIA 33-pin connector.....	5-2
KCAB-PIO cable assembly.....	5-3

## **6 Cabling and Wiring**

Introduction .....	6-2
Connecting an SSIO-24, ERB-24, ERA-01, or SRA-01 .....	6-2
Connecting an STP-37 or STA-U.....	6-3
Connecting special-purpose I/O circuits .....	6-4
Connecting a contact-closure monitor to an input.....	6-4
Connecting an input to a debounce circuit .....	6-4
Connecting an output to Darlington NPN for relay control .....	6-5

## **7 Optional Accessories**

## **A Specifications**



# List of Illustrations

---

## 1 Introduction

Figure 1-1 System configuration ..... 1-2

## 3 Theory of Operation

Figure 3-1 Digital input/output diagram ..... 3-3

## 5 External Connections

Figure 5-1 PCMCIA 33-pin connector ..... 5-2

Figure 5-2 KPCMCIA-PIO24 output connections using the optional KCAB-PIO ..... 5-3

## 6 Cabling and Wiring

Figure 6-1 KPCMCIA-PIO24 and attached I/O cable ..... 6-2

Figure 6-2 Attaching an SSIO-24, ERB-24, ERA-01, or SRA-01 to a KPCMCIA-PIO24 cable ..... 6-2

Figure 6-3 Connecting an STP-37 or STP-37/C to a KPCMCIA-PIO24 ..... 6-3

Figure 6-4 Panel layout of STP-37 and STP-37/C ..... 6-3

Figure 6-5 Contact-closure monitor for a KPCMCIA-PIO24 input ..... 6-4

Figure 6-6 Debounce circuit for a KPCMCIA-PIO24 input ..... 6-4

Figure 6-7 Darlington NPN relay control for an output of a KPCMCIA-PIO24 ..... 6-5

# List of Tables

---

## 4 Register Descriptions

Table 4-1	Program registers .....	4-2
Table 4-2	Data port A control register .....	4-2
Table 4-3	Data port B control register.....	4-3
Table 4-4	Data port C control register.....	4-3
Table 4-5	Port C interrupt control register .....	4-4
Table 4-6	Interrupt mode control register.....	4-5
Table 4-7	Interrupt status register (read only).....	4-6
Table 4-8	Interrupt status register (write only).....	4-6

---

# 1 Introduction

The KPCMCIAPIO24 is a 24 channel digital input/output adapter for systems equipped with PCMCIA Type II and/or Type III expansion sockets.

## Features

- PC Card Standard Specifications 2.1 compliant
- 24 TTL compatible digital I/O channels
- Channels individually programmable as either input or output
- Eight of the I/O channels may be used as interrupt sources
- Active high sensitive, active low sensitive, low-to-high transition, or high-to-low transition interrupt modes
- External interrupt available

## System configuration

Figure 1-1 shows a complete KPCMCIAPIO24 system. For applications requiring discrete wire hook-ups, an optional screw terminal adapter is available to convert the D-37 connector into 37 discrete terminal blocks. Optional accessories are described in Section 7.

*Figure 1-1*  
**System configuration**

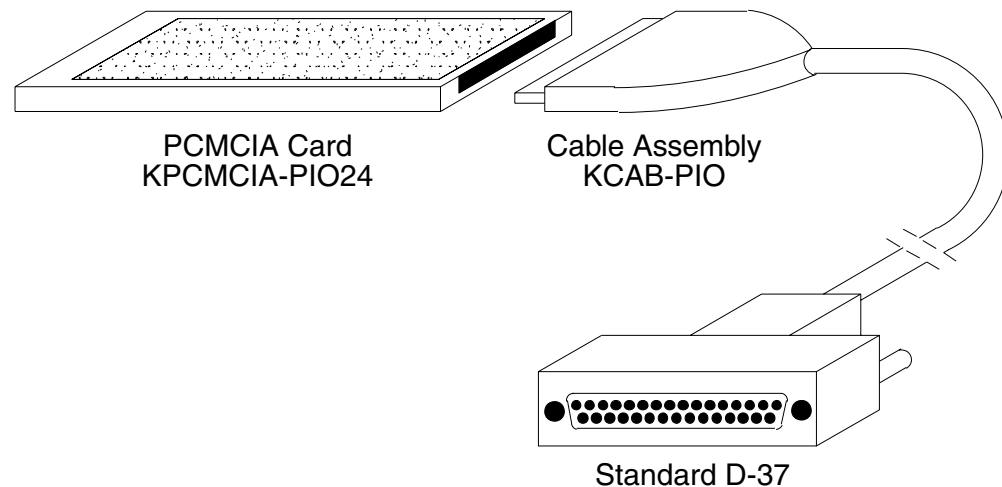

## Technical support

Before returning any equipment for repair, call Keithley Instruments, Inc., for technical support at:

**1-888-KEITHLEY**

**Monday - Friday, 8:00 a.m. - 5:00 p.m., Eastern Time**

An applications engineer will help you diagnose and resolve your problem over the telephone.

If a telephone resolution is not possible, the applications engineer will issue you a Return Material Authorization (RMA) number and ask you to return the equipment. Include the RMA number with any documentation regarding the equipment.

When returning equipment for repair, include the following information:

- Your name, address, and telephone number.
- The invoice or order number and date of equipment purchase.
- A description of the problem or its symptoms.
- The RMA number on the outside of the package.

Repackage the equipment, using the original anti-static wrapping, if possible, and handle it with ground protection. Ship the equipment to:

**ATTN: RMA # \_\_\_\_\_**  
**Repair Department**  
**Keithley Instruments, Inc.**  
**28775 Aurora Road**  
**Cleveland, Ohio 44139**

**Telephone 1-888-KEITHLEY**  
**FAX (440) 248-6168**

**NOTES**     *If you are submitting your equipment for repair under warranty, you must include the invoice number and date of purchase.*

*To enable Keithley Instruments, Inc., to respond as quickly as possible, you must include the RMA number on the outside of the package.*

---

# 2 Installation

## **Hardware setup**

To install a KPCMCIA-PIO24 PC card, insert the adapter into any type II PCMCIA socket. All other configuration options are determined by the DriverLINX software and operating system, as discussed in your DriverLINX documentation.

## **Software setup**

Refer to your DriverLINX documentation for a detailed description of the software installation procedure.

---

**3**

# Theory of Operation



## I/O port description

The 24 digital I/O channels that are provided in the KPCMCIA-PIO24 are grouped into three different ports with each port containing eight digital I/O channels. These three ports are controlled via the data port A control register, data port B control register, and data port C control register. In each of these three registers, each bit corresponds to one data line. The data port A control register is used to access data lines DATA7 through DATA0. The data port B control register is used to access data lines DATA15 through DATA8. The data port C control register is used to access data lines DATA23 through DATA16.

Each of the 24 I/O channels (DATA23 through DATA0) may be individually programmed for either input or output. Each data port is latched on a write to that particular port. Each I/O channel may be programmed for input by writing a 1 to the appropriate bit in the corresponding data port control register. Each I/O channel is driven by an open-collector driver. Therefore, writing a 1 will turn the open-collector output driver off. When off, the open-collector output driver is tri-stated. Tri-stating the output driver of an I/O channel allows that I/O channel to be driven by another device. An I/O channel that is configured for input may be accessed by reading the appropriate data port control register. If a 0 is latched on a particular I/O channel by writing a 0 to the appropriate bit in the corresponding data port control register, the channel may not be used as input. The channel will be masked, and a 0 will always be read on the channel.

If an I/O channel is to be used as output, the appropriate data port control register should be written. When a write operation is performed, the data is latched. If a bit is written with a 0, the open-collector output driver will be turned on, and the I/O channel will be driven to a low voltage state. Writing a 1 to the appropriate bit will turn the open-collector driver off, but a pull-up resistor will pull the particular I/O channel to a TTL high voltage level.

Upon reset of the KPCMCIA-PIO24, the three data port control registers are all latched with a value of FFh. This forces all 24 open-collector output drivers off upon a system power-up or a KPCMCIA-PIO24 card insertion. Thus, all 24 I/O channels are configured as input by default. Care should be taken prior to programming any of these I/O channels for output. The open-collector drivers should not be turned on (by writing a 0 to the appropriate bit of a data port control register) if the I/O channel is driven by another device. Driving the channel low by latching a 0 into a bit of the data port control register may cause damage to the peripheral, the host system, or the KPCMCIA-PIO24 card if the channel is also driven by a peripheral.

## Port C interrupts description

The eight port C I/O channels (DATA23 through DATA16) may also be configured as interrupt sources. If any of these eight I/O channels is to be used to generate an interrupt, the I/O channel must be configured for input by latching the appropriate bit in the data port C control register to 1. Also, the interrupt must be enabled by setting the appropriate bit in the port C interrupt enable register. Eight interrupt sources (INT7 through INT0) may be enabled in this manner. Each of these interrupt sources corresponds to an I/O channel in port C.

The mode of the port C interrupt sources may be configured in one of four possible manners: level sensitive active low interrupt, level sensitive active high interrupt, high-to-low transition edge sensitive interrupt, and low-to-high transition edge sensitive interrupt. The lower nibble (4 bits) and upper nibble (4 bits) of the port C interrupt sources may be configured separately. This will allow INT7 through INT4 to be configured for a different mode than INT3 through INT0. These modes are configured by writing the interrupt mode control register.

Whenever an interrupt is generated due to a port C interrupt source, the corresponding bit of the interrupt status register is set to reflect the cause of the interrupt. This provides a mechanism for determining the source of a detected interrupt. The interrupt status register will be continually updated as additional interrupt generating conditions appear.

Writing a 1 to the appropriate bit of the interrupt acknowledge register is the method by which interrupts should be acknowledged. After a write to the interrupt acknowledge register, another interrupt will be generated if the interrupt status register does not contain a value of 00h. Any bit in the interrupt status register that has a value of 1 can be reset to a value of 0 if the following two conditions are met: the corresponding bit in the interrupt acknowledge register must be written with a 1, and the interrupt generating condition must no longer exist. For level sensitive interrupts, an interrupt will be immediately generated after the write of the interrupt acknowledge register if the interrupt generating condition (active level on port C interrupt source) remains.

## External interrupt description

In addition to the eight port C interrupt sources, an additional external interrupt source is provided in the KPCMCIA-PIO24. This external interrupt source is accessed through Pin 1 of the external connector. The external interrupt source permits the KPCMCIA-PIO24 to be operated with 24-bit input/output and one separate interrupt source.

The interrupt mode control register provides a means of enabling/disabling this external interrupt, setting the external interrupt mode, reading the status of the external interrupt, and acknowledging the external interrupt. The functionality of this external interrupt source is identical to that described for the port C interrupt sources in the previous section.

## Digital input/output

For applications using the KPCMCIA-PIO24 at output logic control the following information applies. After insertion into the PCMCIA socket prior to initialization, the 24 digital I/O lines are set up for input. Therefore, by virtue of the PC Card 10k $\Omega$  pull-up resistor, all outputs have a 5V signal impressed on them. Without a current sink impedance that would pull down the signal, these digital lines will appear to be TTL Logic ON states to a high impedance interfaces. This is a consideration for applications that would be adversely affected by the temporary effective ON state prior to card initialization. See Figure 3-1.

Figure 3-1  
**Digital input/output diagram**

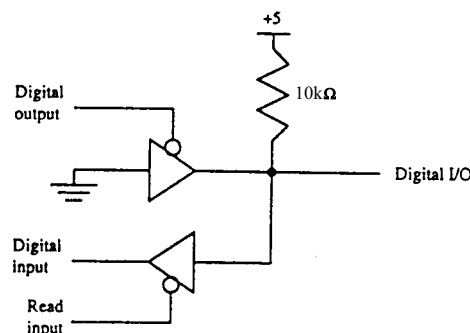

---

# 4

## Register Descriptions

## Introduction

The program registers of the KPCMCIA-PIO24 occupy eight contiguous bytes of I/O address space. These registers must be programmed to control the operation of the KPCMCIA-PIO24. Table 4-1 lists the program registers along with their offsets relative to the I/O space base address at which the KPCMCIA-PIO24 is located.

Each KPCMCIA-PIO24 register is discussed in detail in the following paragraphs.

Table 4-1  
**Program registers**

Offset	Read/Write	Register
0	R/W	Data port A control register
1	R/W	Data port B control register
2	R/W	Data port C control register
5	R/W	Port C interrupt enable register
6	R/W	Interrupt mode control register
7	R	Interrupt status register
7	W	Interrupt acknowledge register

## Data port A control register (base + 0)

The data port A control register, Table 4-2, contains the control bits for I/O channels DATA0 through DATA7. Each I/O channel may be individually programmed for input by writing a 1 to the appropriate bit of this register.

Table 4-2  
**Data port A control register**

Bit	Name	Description
7	DATA7	General purpose I/O bit 7
6	DATA6	General purpose I/O bit 6
5	DATA5	General purpose I/O bit 5
4	DATA4	General purpose I/O bit 4
3	DATA3	General purpose I/O bit 3
2	DATA2	General purpose I/O bit 2
1	DATA1	General purpose I/O bit 1
0	DATA0	General purpose I/O bit 0

## Data port B control register (base + 1)

The data port B control register, Table 4-3, contains the control bits for I/O channels DATA8 through DATA15. Each I/O channel may be individually programmed for input by writing a 1 to the appropriate bit of this register.

Table 4-3

**Data port B control register**

Bit	Name	Description
7	DATA15	General purpose I/O bit 15
6	DATA14	General purpose I/O bit 14
5	DATA13	General purpose I/O bit 13
4	DATA12	General purpose I/O bit 12
3	DATA11	General purpose I/O bit 11
2	DATA10	General purpose I/O bit 10
1	DATA9	General purpose I/O bit 9
0	DATA8	General purpose I/O bit 8

## Data port C control register (base + 2)

The data port C control register, Table 4-4, contains the control bits for I/O channels DATA16 through DATA23. Each I/O channel may be individually programmed for input by writing a 1 to the appropriate bit of this register. In addition, any of these eight I/O channels that are programmed for input may also be used to generate interrupts. In order to program an I/O channel as an interrupt source, the port C interrupt enable register must be set appropriately. The I/O channel must also be programmed for input by writing a 1 to the appropriate bit of the data port C control register.

Table 4-4

**Data port C control register**

Bit	Name	Description
7	DATA23/INT7	General purpose I/O bit 23 and interrupt line 7
6	DATA22/INT6	General purpose I/O bit 22 and interrupt line 6
5	DATA21/INT5	General purpose I/O bit 21 and interrupt line 5
4	DATA20/INT4	General purpose I/O bit 20 and interrupt line 4
3	DATA19/INT3	General purpose I/O bit 19 and interrupt line 3
2	DATA18/INT2	General purpose I/O bit 18 and interrupt line 2
1	DATA17/INT1	General purpose I/O bit 17 and interrupt line 1
0	DATA16/INT0	General purpose I/O bit 16 and interrupt line 0

## Port C interrupt enable register (base + 5)

INT7 through INT0 may be enabled by writing the appropriate bits in the port C interrupt enable register. The corresponding I/O channel must be configured as an input channel via the data port C control register if an interrupt is to be generated. If an I/O channel is configured as an interrupt source (INT7 through INT0), the I/O channel continues to be a standard data input channel (DATA23 through DATA16) and may be read as any other input signal is read. See Table 4-5.

Table 4-5

### Port C interrupt control register

Bit	Name	Description
7	INT7EN	1 = enables INT7; 0 = disables INT7
6	INT6EN	1 = enables INT6; 0 = disables INT6
5	INT5EN	1 = enables INT5; 0 = disables INT5
4	INT4EN	1 = enables INT4; 0 = disables INT4
3	INT3EN	1 = enables INT3; 0 = disables INT3
2	INT2EN	1 = enables INT2; 0 = disables INT2
1	INT1EN	1 = enables INT1; 0 = disables INT1
0	INT0EN	1 = enables INT0; 0 = disables INT0

## Interrupt mode control register (base + 6)

The mode of both the external interrupt and the port C interrupts may be controlled with the interrupt mode control register. The upper nibble (4 bits) and lower nibble (4 bits) of the port C interrupts may be configured separately. The external interrupt can also be enabled by writing this register. The status of the external interrupt can be read in this register, and the external interrupt can also be acknowledged by writing the appropriate bit in the interrupt mode control register. See Table 4-6.

Table 4-6  
**Interrupt mode control register**

Bit	Name	Description
7	ExtIntStat(Read) ExtIntAck(Write)	ExtIntStat: to read status of external interrupt ExtIntAck: write acknowledges external interrupt
6	ExtraIntEn	1 = external interrupt is enabled 0 = external interrupt is disabled
5:4	ExtIntControl	These two bits control the mode of the external interrupt: 00 = Level sensitive active low interrupt 01 = Level sensitive active high interrupt 10 = High-to-low transition edge sensitive interrupt 11 = Low-to-high transition edge sensitive interrupt
3:2	UpperIntCntrl	These two bits control the mode of the upper nibble of port C (INT7, INT6, INT5, INT4): 00 = Level sensitive active low interrupt 01 = Level sensitive active high interrupt 10 = High-to-low transition edge sensitive interrupt 11 = Low-to-high transition edge sensitive interrupt
1:0	LowerIntCntrl	These two bits control the mode of the lower nibble of port C (INT3, INT2, INT1, INT0): 00 = Level sensitive active low interrupt 01 = Level sensitive active high interrupt 10 = High-to-low transition edge sensitive interrupt 11 = Low-to-high transition edge sensitive interrupt

## Interrupt status register (read only, base + 7)

On a read, this register provides the interrupt status for the port C interrupts. This provides a mechanism for determining the sources of any pending interrupts. A 1 signals that an interrupt generating condition has occurred on the appropriate channel. Interrupts will continue to occur until this register has a value of 00h and no interrupt generating conditions remain. This register must be reset by acknowledging interrupts by writing the interrupt acknowledge register. See Table 4-7.

Table 4-7

### *Interrupt status register (read only)*

Bit	Name	Description
7:0	ChanCIntStatus	The Status of INT7 - INT0 is read (Bit 7 = INT7, Bit 6 = INT6, etc...)

## Interrupt acknowledge register (write only, base + 7)

Writing a 1 to any bit in the interrupt acknowledge register will acknowledge the interrupt generating condition that was represented in the corresponding bit of the interrupt status register. If a 1 is written to a bit in the interrupt acknowledge register and the corresponding interrupt generating condition is not present, then the appropriate bit in the interrupt status register will be reset (set to 0). See Table 4-8.

Table 4-8

### *Interrupt status register (write only)*

Bit	Name	Description
7:0	ChanCIntAck	Written to acknowledge INT 7- INT0 (Bit 7 = INT7, Bit 6 = INT6, etc...)



## Summary of interrupt source options

Two interrupt source options are provided in the KPCMCIPI-PIO24 and are summarized below:

### 1. Port C interrupt sources

- The following must be programmed:
  - Channel set for input by the data port C control register.
  - Interrupt source enabled by the port C interrupt enable register.
  - Mode selected by the interrupt mode control register.
- Interrupt generated unless interrupt status register is 00h.
  - Interrupt is generated after write of interrupt acknowledge register if any interrupts remain unacknowledged.
  - Unacknowledged interrupts are represented by a '1' in the interrupt status register.
- 1 in interrupt status register is reset to '0' if the following two requirements are satisfied:
  - Interrupt acknowledged by writing appropriate bit in interrupt acknowledge register with '1'.
  - Condition which caused interrupt is no longer present.

### 2. External interrupt source

- The following must be programmed:
  - Interrupt source enabled by the interrupt mode control register.
  - Mode selected by the interrupt mode control register.
- Interrupt generated if ExtIntStat of interrupt mode control register is '1'.
- 1 in ExtIntStatus is reset to '0' if the following two requirements are satisfied:
  - Interrupt acknowledged by writing ExtIntAck with '1'.
  - Condition which caused interrupt is no longer present.

## Summary of input/output options

Each of the three ports (Port A, Port B, Port C) may be configured in one of three manners:

- **Port used as an output**
  - Write a '1' to the appropriate bits of the latch in order to turn off the output module.
  - Write a '0' to the appropriate bits of the latch in order to turn on the output module.
- **Port used as an input**
  - Writing a '1' to all the bits of the latch will allow all the channels of the port to be read as inputs.
  - Writing a '0' to any bits of the latch will mask those bits. Those bits will always be read as a '0'.

- **Port used as input and output**

If a port is to be used so that some channels are inputs and some channels are outputs, it must be insured that the channels to be used as inputs are initialized as inputs. This is done by writing a '1' to the bits of the data port control register representing the I/O channels, which are to be used as inputs anytime the port is written.

- The channels which are to be inputs should always be written with a 1 and never written with a '0'.
- The channels which are to be outputs should be written with the appropriate value (0 or 1).
- The channels which are latched with a '0' will always be '0' when read (they are masked from input).

## Programming example

The following C program segment demonstrates how to program a KPCMCIA-PIO24 located at I/O base address 300h. Port A will be programmed as output, and 55h will be latched at port A. Port B will be configured with its upper 3 bits as output and its lower five bits as input. The upper three bits will be latched with 010b. Port C will be configured as input. Interrupts will be enabled as explained in the program comments.

```
    outp(0x300,0x55);          /* writes 55h to port A */
    outp(0x301,0x5F);          /* writes 010b to port B upper 3 bits */
                                /* sets port B lower 5 bits for input */
    outp(0x302,0xFF);          /* initializes port C for input */
    Port_B = inp(0x301);        /* reads data from port B */

/* Port_B(bit7) = '0' and Port_B(bit5) = '0' due to 'masking' */

    Port_C = inp(0x302);        /* reads data from port C */
    outp(0x306,0x76);
    /* INT7 - INT4 set for level sensitive active high interrupt mode */
    /* INT3 - INT0 set for edge sensitive high-to-low transition interrupt source */
    /* External interrupt source enabled */
    /* External interrupt source set for low-to-high edge sensitive interrupt source */
    outp(0x305,0x77);
    /* Enables six port C interrupt sources */
    /* Enables INT6,INT5,INT4,INT2,INT1,INT0 */
```

---

**5**

# External Connections

# PCMCIA 33-pin connector

The KPCMCIA-PIO24 is fitted with a 33-pin 0.8mm shielded connector with the pins assigned as shown in Figure 5-1.

Figure 5-1  
PCMCIA 33-pin connector

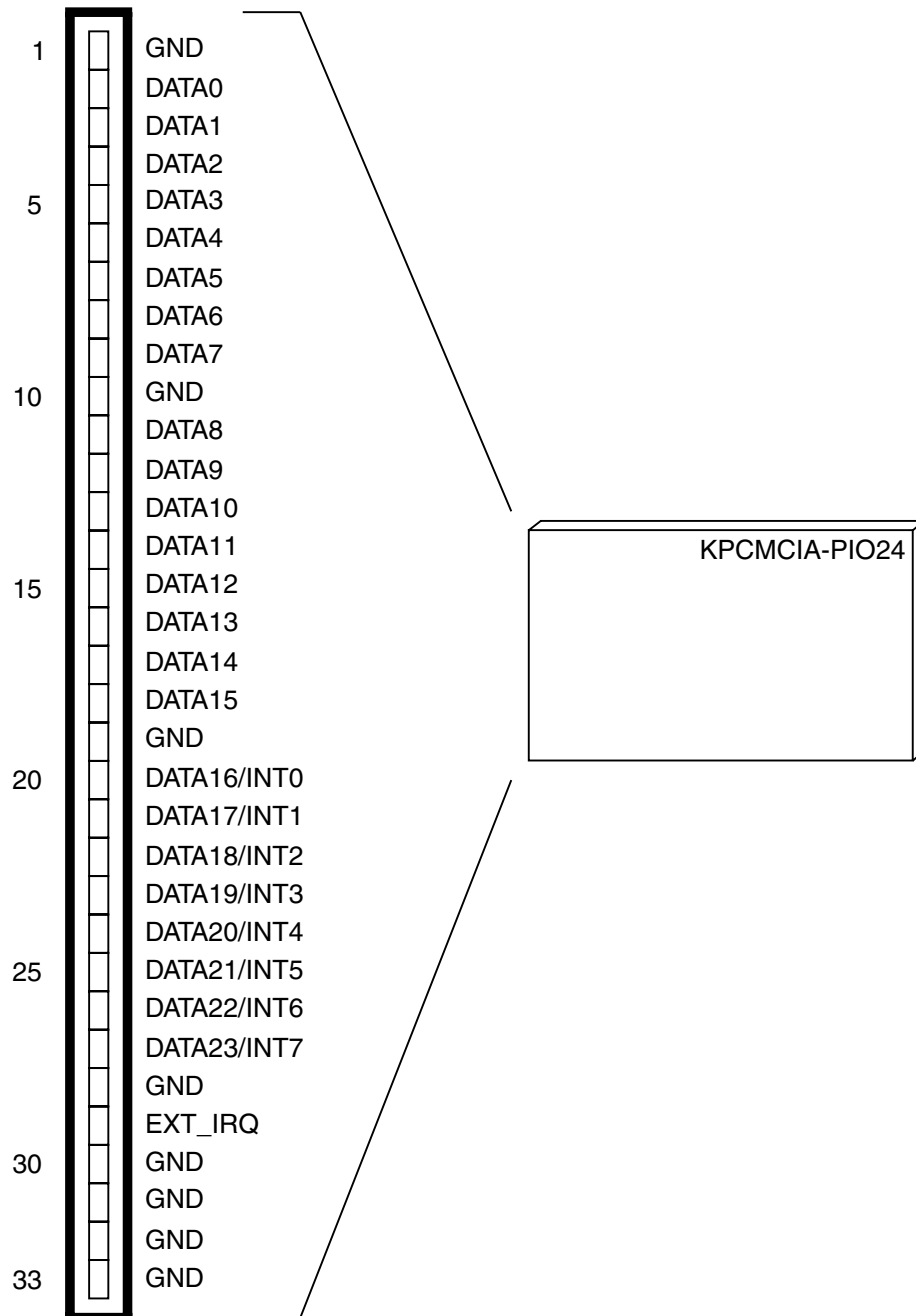

## KCAB-PIO cable assembly

Keithley part number KCAB-PIO, converts the KPCMCIA-PIO24's 33-pin 0.8mm I/O connector to a standard D-37 male connector. See Figure 5-2.

Figure 5-2

**KPCMCIA-PIO24 output connections using the optional KCAB-PIO.**

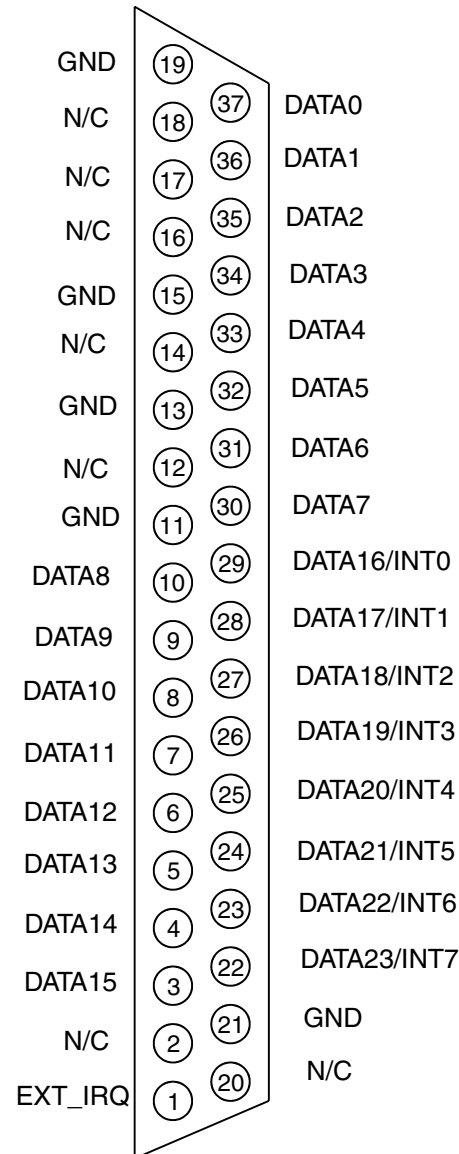

---

# 6 Cabling and Wiring

## Introduction

This section describes how to wire accessories and signals to your KPCMCIA-PIO24. The KPCMCIA-PIO24 and I/O cable appear as shown in Figure 6-1.

The main I/O connector of the KPCMCIA-PIO24 cable is a female, 37-pin, D type. Pin assignments for this connector are shown in Figure 5-2.

Figure 6-1  
KPCMCIA-PIO24 and attached I/O cable

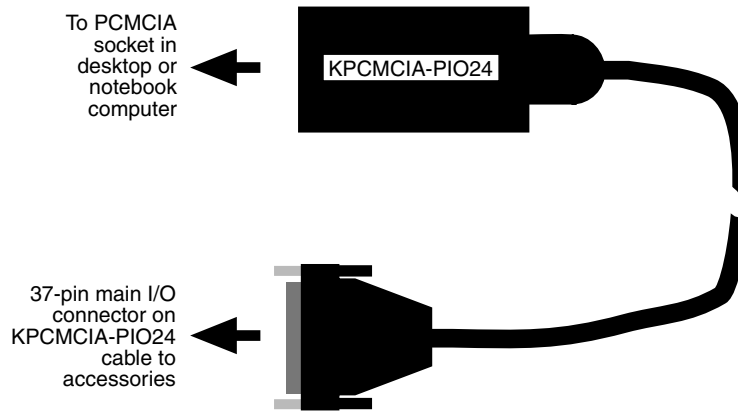

## Connecting an SSIO-24, ERB-24, ERA-01, or SRA-01

The following accessories attach directly to the I/O cable of a KPCMCIA-PIO24, as shown in Figure 6-2: SSIO-24, ERB-24, ERA-01, and SRA-01.

**NOTE** *Each of these accessories requires external power when connected to a KPCMCIA-PIO24. To ensure correct power connections, be sure to refer to the user manuals for these accessories.*

Figure 6-2  
Attaching an SSIO-24, ERB-24, ERA-01, or SRA-01 to a KPCMCIA-PIO24 cable

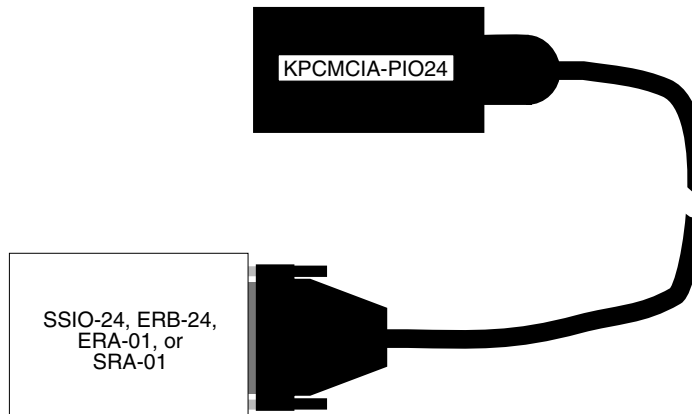

## Connecting an STP-37 or STA-U

The STP-37 and STA-U are screw-terminal panels that attach to the main I/O connector of a KPCMCIA-PIO24 cable, as shown in Figure 6-3. The STP-37/C is the STP-37 with a protective bottom cover. While Figure 6-3 shows a STP-37 or STP-37/C, the STA-U attaches to the KPCMCIA-PIO24 cable in exactly the same manner. The STP-37 and STP-37/C appear as shown in Figure 6-4.

Figure 6-3  
Connecting an STP-37 or STP-37/C to a KPCMCIA-PIO24

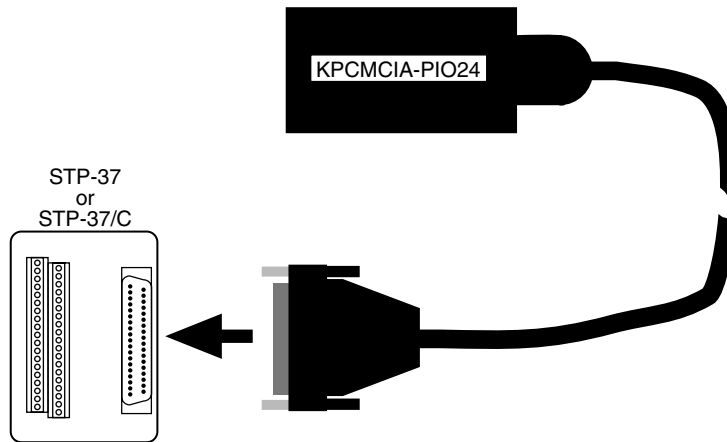
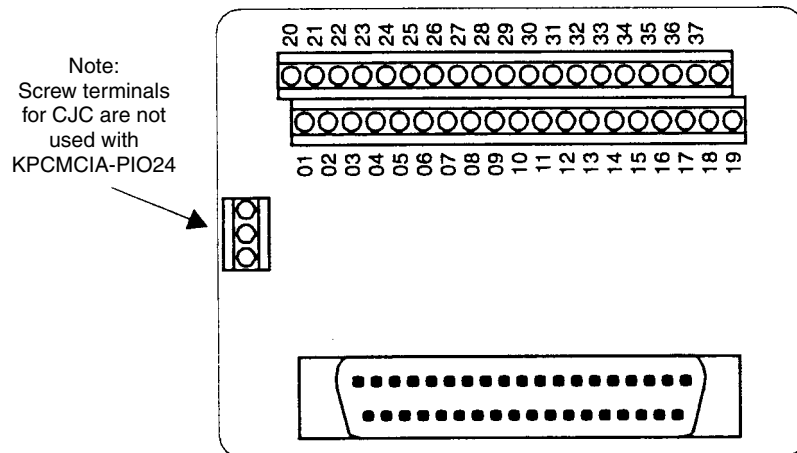

Figure 6-4  
Panel layout of STP-37 and STP-37/C





## Connecting special-purpose I/O circuits

The following paragraphs describe commonly used circuits for the inputs or outputs of a KPCMCIA-PIO24.

### Connecting a contact-closure monitor to an input

Figure 6-5 shows a circuit for monitoring contact closure at a KPCMCIA-PIO24 input.

Figure 6-5  
*Contact-closure monitor for a KPCMCIA-PIO24 input*

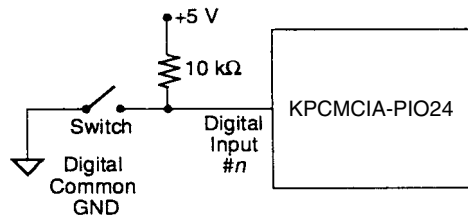

**NOTE** The circuit in Figure 6-5 does not contain a debounce circuit. Debounce can be handled by your application program or by the circuit described in the following paragraphs.

### Connecting an input to a debounce circuit

Since debounce can be handled by your application program, Figure 6-6 shows a debounce circuit you can use at an input of a KPCMCIA-PIO24.

Figure 6-6  
*Debounce circuit for a KPCMCIA-PIO24 input*

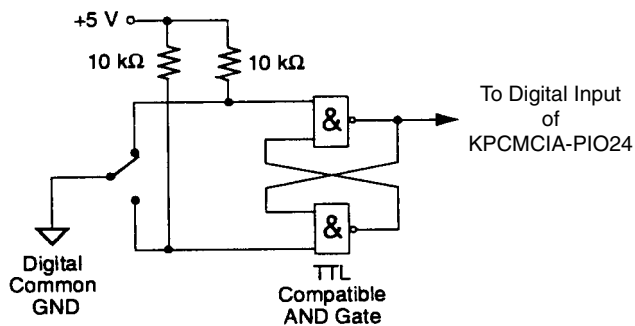

## Connecting an output to Darlington NPN for relay control

You can achieve relay control at an output of a KPCMCIA-PIO24 using a Darlington NPN transistor, as shown in Figure 6-7.

Figure 6-7

**Darlington NPN relay control for an output of a KPCMCIA-PIO24**

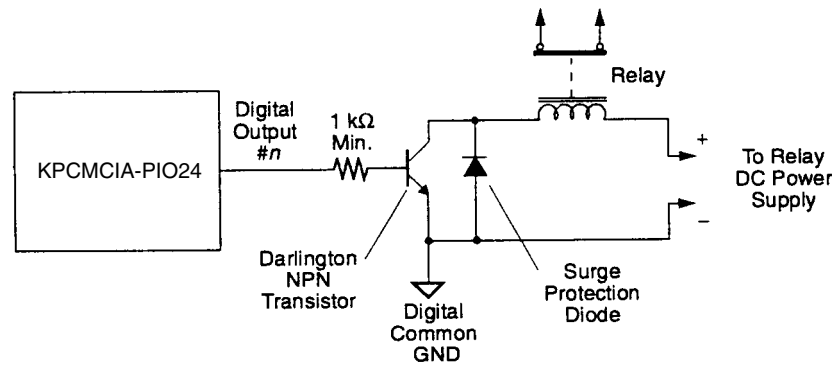



**7**

# Optional Accessories

The following accessories are also available for use with your KPCMCI A-PIO24:

**SSIO-24** — is a 24-channel mounting panel for up to 24 solid-state, miniature I/O modules with functions of DC input, DC output, AC input, and AC output. The SSIO-24 connects to the main I/O connector of the KPCMCI A-PIO24 cable. It requires external power (+5VDC) when used with the KPCMCI A-PIO24.

**ERB-24** — is a relay board that provides 24 electromechanical double-pole, double-throw relays for controlling and switching up to 3A and 120V<sub>rms</sub>. The ERB-24 connects to the main I/O connector of the KPCMCI A-PIO24 cable. It has a built-in power supply requiring 115/230VAC.

**ERA-01** — is an electrical relay board containing eight single-pole, double-throw relays that can switch up to 3A at 120V<sub>rms</sub>. The ERA-01 requires external power (+5VDC) when used with the KPCMCI A-PIO24.

**SRA-01** — is an 8-channel, solid-state, mounting panel for industry-standard I/O modules used in sensing and controlling AC and DC circuits. The SRA-01 requires external power (+5VDC) when used with the KPCMCI A-PIO24.

**STP-37** — is a screw-terminal panel for general-purpose connections in a compact form factor.

**STA-U** — is a universal screw-terminal accessory that connects to the main I/O connector of the KPCMCI A-PIO24 to bring the card's I/O signals to convenient screw terminals.

Refer to the Keithley catalog or contact your local sales office for information on obtaining these accessories.

---

# A Specifications

---

<b>Bus interface</b>	PCMCIA PC card standard 2.1 compliant
<b>Physical dimensions</b>	Type II PCMCIA card (5mm)
<b>Power requirements</b>	+5 volts 7.33mA typical (all outputs off) 12.38mA maximum (all outputs off) 36.38mA maximum (all outputs on)
<b>Digital input/output</b>	TTL Compatible
<b>Current source/sink</b> (at 25°C)	Sink 6mA (min) at 0.33V Sink 20mA (min) at 1.0V Source 1.1mA max into 0Ω at V <sub>CC</sub> =5V
<b>Input/output current</b>	25mA maximum
<b>Connector</b>	Adapter to standard male D-37

# Index

---

## C

- Cabling and wiring 6-1
- Connecting a contact-closure monitor to an input 6-4
- Connecting an input to a debounce circuit 6-4
- Connecting an output to Darlington NPN for relay control 6-5
- Connecting an SSIO-24, ERB-24, ERA-01, or SRA-01 6-2
- Connecting an STP-37 or STA-U 6-3
- Connecting special-purpose I/O circuits 6-4

## D

- Data port A control register (base + 0) 4-2
- Data port B control register (base + 1) 4-3
- Data port C control register (base + 2) 4-3
- Digital input/output 3-3

## E

- External connections 5-1
- External interrupt description 3-3

## F

- Features 1-2

## H

- Hardware setup 2-2

## I

- Installation 2-1
- Introduction 1-1, 4-2, 6-2
- I/O port description 3-2
- Interrupt acknowledge register (write only, base + 7) 4-6
- Interrupt mode control register (base + 6) 4-5
- Interrupt status register (read only, base + 7) 4-6

## K

- KCAB-PIO cable assembly 5-3

## O

- Optional accessories 7-1

## P

- PCMCIA 33-pin connector 5-2
- Port C interrupt enable register (base + 5) 4-4
- Port C interrupts description 3-2
- Programming example 4-8

## R

- Register descriptions 4-1

## S

- Software setup 2-2
- Specifications A-1
- Summary of input/output options 4-7
- Summary of interrupt source options 4-7
- System configuration 1-2

## T

- Technical support 1-3
- Theory of operation 3-1

Specifications are subject to change without notice.

All Keithley trademarks and trade names are the property of Keithley Instruments, Inc. All other trademarks and trade names are the property of their respective companies.

**KEITHLEY**

**Keithley Instruments, Inc.**

28775 Aurora Road • Cleveland, Ohio 44139 • 440-248-0400 • Fax: 440-248-6168  
1-888-KEITHLEY (534-8453) • [www.keithley.com](http://www.keithley.com)

**Sales Offices: BELGIUM:**

Bergensesteenweg 709 • B-1600 Sint-Pieters-Leeuw • 02-363 00 40 • Fax: 02/363 00 64

**CHINA:**

Yuan Chen Xin Building, Room 705 • 12 Yumin Road, Dewai, Madian • Beijing 100029 • 8610-6202-2886 • Fax: 8610-6202-2892

**FINLAND:**

Tietäjäsentie 2 • 02130 Espoo • Phone: 09-54 75 08 10 • Fax: 09-25 10 51 00

**FRANCE:**

3, allée des Garays • 91127 Palaiseau Cédex • 01-64 53 20 20 • Fax: 01-60 11 77 26

**GERMANY:**

Landsberger Strasse 65 • 82110 Germering • 089/84 93 07-40 • Fax: 089/84 93 07-34

**GREAT BRITAIN:**

Unit 2 Commerce Park, Brunel Road • Theale • Berkshire RG7 4AB • 0118 929 7500 • Fax: 0118 929 7519

**INDIA:**

Flat 2B, Willocrissa • 14, Rest House Crescent • Bangalore 560 001 • 91-80-509-1320/21 • Fax: 91-80-509-1322

**ITALY:**

Viale San Gimignano, 38 • 20146 Milano • 02-48 39 16 01 • Fax: 02-48 30 22 74

**JAPAN:**

New Pier Takeshiba North Tower 13F • 11-1, Kaigan 1-chome • Minato-ku, Tokyo 105-0022 • 81-3-5733-7555 • Fax: 81-3-5733-7556

**KOREA:**

2FL., URI Building • 2-14 Yangjae-Dong • Seocho-Gu, Seoul 137-888 • 82-2-574-7778 • Fax: 82-2-574-7838

**NETHERLANDS:**

Postbus 559 • 4200 AN Gorinchem • 0183-635333 • Fax: 0183-630821

**SWEDEN:**

c/o Regus Business Centre • Frosundaviks Allé 15, 4tr • 169 70 Solna • 08-509 04 679 • Fax: 08-655 26 10

**SWITZERLAND:**

Kriesbachstrasse 4 • 8600 Dübendorf • 01-821 94 44 • Fax: 01-820 30 81

**TAIWAN:**

1FL., 85 Po Ai Street • Hsinchu, Taiwan, R.O.C. • 886-3-572-9077 • Fax: 886-3-572-9031