

AIM3A

Analog Input Module

Introduction

The AIM3A analog input module accepts input signals of $\pm 100\text{mV}$ full scale through $\pm 10\text{V}$ full scale, and outputs a signal of $\pm 10\text{V}$ full scale to the A/D converter module in slot 1 of the data acquisition system. The AIM3A can accept 32 single-ended (common ground) inputs, or 16 differential (floating) inputs, or a mixture of both. All AIM3A functions, including gain of $\times 1$, $\times 10$, and $\times 100$, are programmable, permitting single-ended and differential inputs to be intermixed with a different gain setting for each channel. Full 16-bit precision results from the AIM3A's low-noise instrumentation amplifier, linearity of 0.005%, and attention to design, signal routing, and shielding. When used with an AMM1A (AMM2) A/D module, the AIM3A will support 50kHz (62.5kHz) measurements at any gain and channel mix.

The AIM3A can be configured to accept current inputs by installing appropriate current sensing resistors in the op-

tional resistor locations provided on the module. The input signals are connected to removable screw terminal strips. Alternately, a user-installed mass termination connector is available for single-ended channels 0-7 and 16-32, or differential channels 0-7. The mass termination connector uses the pin out format of the Analog Devices 3B mainframe ribbon cable connector to permit direct connection of the AIM3A to a 3B signal conditioning subsystem.

Hardware Compatibility

The AIM3A can be used in slots 2 through 10 of the 500A and 500P. Up to 9 AIM3A modules can be used in these systems for a maximum of 304 analog input channels (32 SE channels per AIM3A plus 16 SE channels on the AMMx in slot 1). For best performance, analog modules should be mounted in the lowest-numbered available slots. The AIM3A can also be used in the option slot of the Model 575 or 576 for up to 48 analog input channels (32 SE channels on the AIM3A plus 16 SE channels on the AMMx).

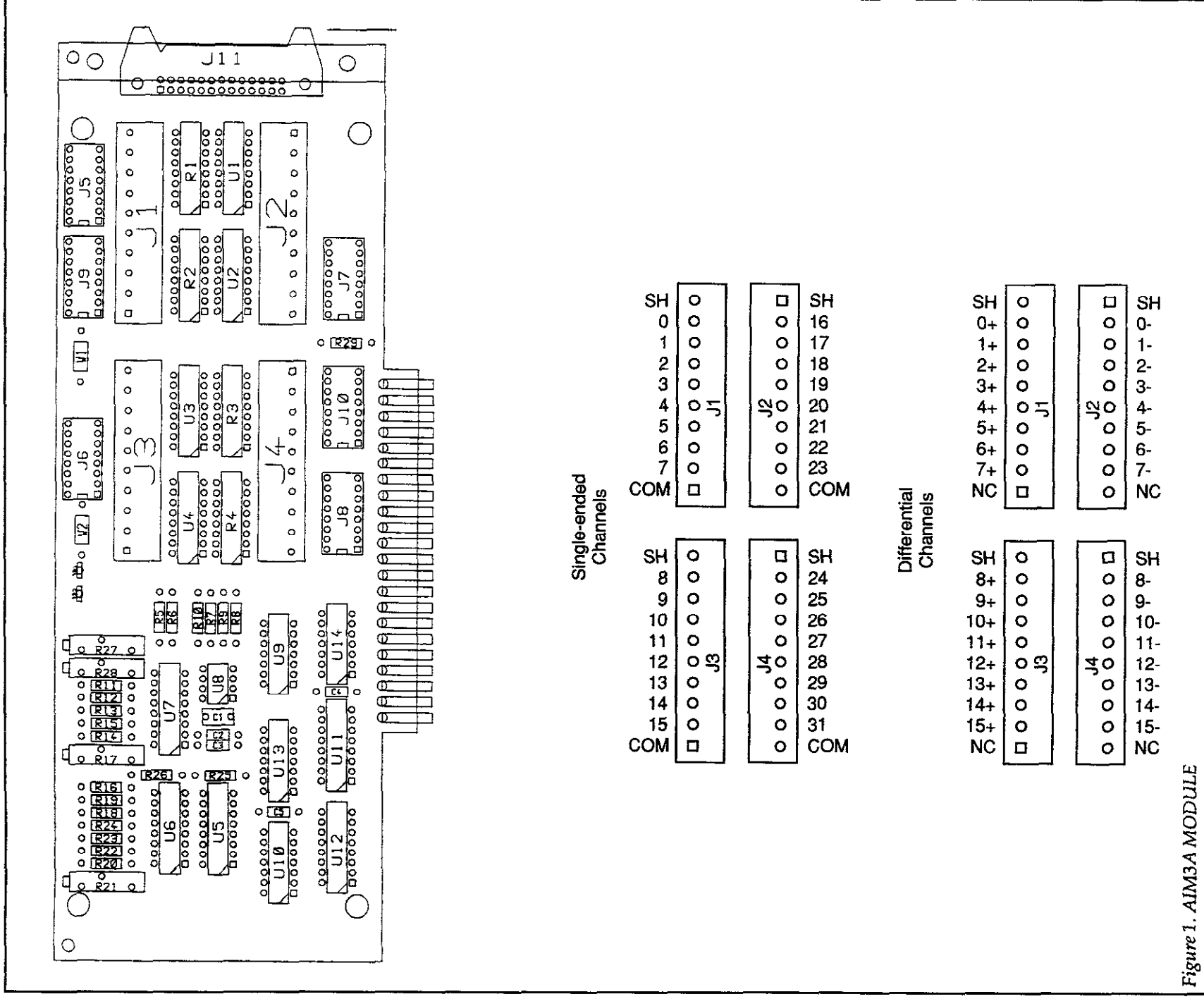

Figure 1. AIM3A MODULE

Software Compatibility

Full control of the AIM3A requires software specifically designed for this module. Keithley's KDAC500 software fully supports the AIM3A. If you are using third-party software, be certain that the software fully supports the AIM3A.

AIM3A Specifications

(Specifications apply for 18° to 28°C, 1 year)

Input channels: 16 differential or 32 single-ended, software selectable

Input characteristics:

Input Protection: $\pm 30V$ max (powered), $\pm 15V$ max (unpowered)

Input Resistance: $100M\Omega$

Input Bias Current: $50nA$

Software selectable gains:	x1	x10	x100
Input range ($\pm V$):	10	1	0.1
Gain accuracy (% rdg):	0.05	0.01	0.01
Gain Nonlinearity (%):	0.005	0.005	0.005
Gain Tempco (%/ $^{\circ}C$):	0.002	0.002	0.002
Input offset (μV):	250	25	25
Offset Tempco ($\mu V/^{\circ}C$):	50	6	2
Input noise			
(μV RMS, 100KHz BW):	24	2.7	1.3
Settling time to .01%:	15 μs	15 μs	15 μs
CMRR (DC to 60Hz):	70db	90db	100db

Power up conditions: gain = X1, input channels = differential, channel selected = channel 0.

Standard Connections

The input connections to the AIM3A are made through quick-disconnect terminal blocks J1, J2, J3, and J4, or through mass termination J11.

A quick-disconnect terminal block can be removed from the AIM3A to facilitate making connections. Pull the block straight off the board with a firm, even pressure. Do not pry the terminals with a screwdriver or sharp object, or you may damage the circuit board.

Note that each individual terminal on a terminal block consists of a small metal block with a hole and metal compression tab within the hole. To make connections to a

terminal block, first strip 3/16 of insulation from the end of the wire which you want to attach. Loosen the desired terminal screw on the block and insert the bare end of the wire into the corresponding hole. Tighten the screw securely to compress the tab against the wire.

After you have attached all the desired signal wires to a terminal block, replace the terminal block by lining it up with the mating pins on the AIM3A and pressing it back into place.

Alternate connections are available through the optional cable mass termination connector J11. Note that J11 connects only to channels 0 through 7 and 16 through 23 in single-ended mode, or 0 through 7 in differential mode. This connector is available from Scotch/3M as Part Number 3429, and can be easily field-installed if it is needed.

Installation

All features and operating modes of the AIM3A module are programmable with the exception of jumpers W1 and W2 and resistor sockets J5 - J10. Jumpers W1 and W2 connect input low to module ground, and are normally left in place. They may be removed for measurements where remote ground sensing is needed. A jumper may be plain wire, or may resemble a resistor.

Sockets J5 - J10 are used for current sensing resistors, or for ground reference resistors for some types of differential measurements. These are special situations which are covered under the "Applications" topic later in this manual.

CAUTION

Turn off power to the data acquisition system before you insert or remove any module. To minimize the possibility of EMI radiation, always operate the data acquisition system with the cover in place and properly secured.

CAUTION

Make sure you have discharged any static charges on your body before handling the AIM3A. You can do this most easily by simply touching the chassis of a computer or data acquisition mainframe which is plugged into

a grounded, 3-wire outlet. Avoid touching components or the card edge connector of the module.

NOTE

Analog input modules should be placed in the lowest-numbered available slots. This positioning will provide the shortest distance to the Analog Master Measurement module in slot 1, and will also minimize any possibility of noise pick-up from the power supply or other modules.

For a compatible multi-slot data acquisition system (e.g. Model 500A or 500P), remove the top cover of the system by loosening the cover retaining screws located in the upper corners of the rear panel. Slide the cover back about one inch and then lift it off. Insert the AIM3A module in the desired slot with the component side facing the system power supply. Replace the system cover.

In a single-slot system such as the Model 575 or 576, first attach the supplied right-angle bracket to the AIM3A (see Figure 2). Install the AIM3A in the option slot, with the component side of the board facing upward. Secure the bracket to the rear panel of the system. Close and secure the cover.

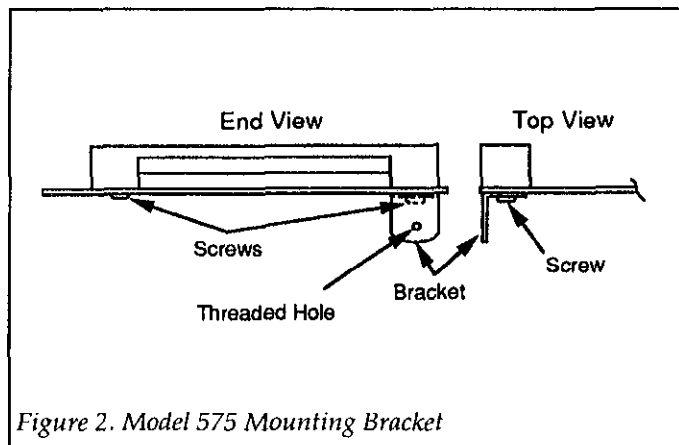

Figure 2. Model 575 Mounting Bracket

Applications

The following brief description of the AIM3A's amplifier circuitry will help you make the most effective use of the module.

The AIM3A has a single, differential instrumentation amplifier that amplifies all input signals, whether single-ended or differential. A differential amplifier responds only to the difference in voltage between two signals connected to its non-inverting (+) and inverting (-) inputs. The common mode voltage is the average of the two input voltages. The actual voltage at each input is not important as long as the common voltage is within the common mode range of the amplifier. The common mode range of the AIM3A will not be exceeded as long as all inputs are within the range -10V to +10V referenced to module ground.

For example, if the input to the (+) input is 9 Volts and the input to the (-) input is 8 Volts, the amplifier will amplify the +1 Volt difference signal and reject (ignore) the 8.5 volt common mode signal at both inputs. The ability to reject the 8.5 Volt common signal is referred to as Common Mode Rejection.

When the AIM3A amplifies a differential input signal, the (+) input of the amplifier is connected to the selected (+) channel on terminal block J1 or J3, and the (-) input of the amplifier is connected to the corresponding (-) channel terminal on J2 or J4. For example, if channel 2 and differential mode are selected, the (+) input of the amplifier is connected to pin 7 of J1, and the (-) input of the amplifier is connected to pin 4 of J2. As long as the voltage at either pin is within +10 to -10 volts as measured to the module ground (pin 10 of J1 and J3, or pin 1 of J2 and J4), the amplifier will amplify the difference between the inputs.

When the AIM3A amplifies a single-ended input signal, the (+) input is connected to the selected channel on terminal block J1, J2, J3, or J4, and the (-) input is connected to one of common input low connections available on J1, J2, J3, or J4.

The jumpers W1 and W2 provide a user-removable connection between the input low connections and module ground, and should normally be left in position. The AIM3A amplifier will now amplify the voltage difference between the selected (+) input terminal and module ground.

As an example, if channel 30 and single-ended mode are selected, the (+) input of the amplifier is connected to pin 8 of J4, and the (-) input of the amplifier is connected to pin 10 of J4 (or pin 1 of J3, since these two pins are internally connected). Pin 10 of J4 and pin 1 of J3 are jumpered to module ground by W2. The amplifier will amplify the difference between pin 8 of J4 and pin 10 of J4.

There are two groups of 16 single-ended input channels, and each group has its own (-) input connection. Single-ended channels 0 through 7 and 16 through 23 form one group, with their (-) input connection brought to pin 1 of J1 and pin 10 of J2. Jumper W1 connects this (-) input connection to the module ground as supplied from the factory. Single-ended channels 8 through 15 and 24 through 31 form the second group, with their (-) input connection brought to pin 1 of J3 and pin 10 of J4. Jumper W2 connects this (-) input connection to the module ground as supplied from the factory.

CAUTION

To minimize the possibility of EMI radiation, use shielded cable for input signals. Connect the shield to module ground, but do not connect the shield at the opposite cable end to anything. The maximum input voltage allowed with module power on is ± 30 Volts, or ± 15 Volts with module power off. If any input exceeds ± 10 Volts, all inputs will be inoperative.

There are several choices for the method of connecting inputs to the AIM3A. You must decide which method will yield the best results for a given application. To achieve 16-bit performance, care must be taken to minimize error sources caused by ground loops and shielding problems. The guidelines for choosing connection methods are as follows:

Single-ended Input, Local Ground Sensing, Using Terminal Blocks

For input sources which can be grounded, but are not connected to a ground of their own, the connections shown in Figure 3 will give good results. The AIM3A provides the ground connection for the input sources. Two possible connections are shown. Sources V0 and V1 have individual cables going to each source. Up to 32 sources can be connected to a single AIM3A in this way. Four input common terminals are provided, one on each connector. Connect all the wires from a single input source to the same connector, as shown for J1 in Figure 3. Sources V16 and V17 show a cable with a single input common wire. This connection method can be used for up to 16 sources in a group where all the sources have one wire in common. The sources in a single group must be connected to channels which all use the same input common connection. There are two input common connections, one for channels 0 through 7 and 16 through 23, and a second input common connection for channels 8 through 15 and 24 through 31.

Single-ended Input, Remote Ground Sensing, Using Terminal Blocks

Figure 4 shows four single-ended inputs connected to the AIM3A using a remote ground sense line. All 16 single-ended inputs on J1 and J2 use a single ground sense line. This method is useful when up to 16 voltage sources to be measured are all located at a single remote location, with one side of each signal source connected to ground at the remote location. There may be a voltage difference between the ground at the remote location and the ground on the AIM3A. This will cause an error in the voltage readings if the connection in Figure 3 is used.

In Figure 4, the ground connection on the AIM3A is disconnected by removing jumper W1. The ground at the remote location is carried to the AIM3A by the remote ground sense wire. The AIM3A will measure the difference between the remote signal, and the remote ground, and eliminate the error caused by the difference in ground voltage between it and the remote location. Two groups of 16 single-ended inputs can be wired this way, with the first group using J1, J2, and W1, and the second group using J3, J4, and W2. Refer also to Figures 10 and 11 later in this manual.

Differential Inputs, Using Terminal Blocks

When there are multiple inputs with different ground points, or the actual ground points are not known, the differential input wiring can be used to prevent ground loop errors and reject common mode noise. Figure 5 shows two inputs connected as differential input channels 2 and 3. Either the (+) or the (-) input on any differential input may be connected to ground, or both may be different from ground. A restriction does exist, however. No input terminal on the AIM3A can be connected to a voltage beyond +10V or -10V with respect to the AIM3A ground reference. If this happens, reading errors may occur on the channel which is greater than 10 volts. At about +15 or -15 volts, other channels will begin to read in error, and above +30V or -30V, the AIM3A will be damaged.

When the AIM3A is used to measure a floating source, the readings may appear noisy, or may fluctuate or rise until they reach the maximum input permitted by the programmed gains. This problem results where the floating source has no low-impedance current return path to ground. Over a period of seconds to minutes, the input of the AIM3A charges off the input signal until the common mode voltage present at the input exceeds the allowable level, and the module no longer functions properly. The

solution is to install a resistor for the affected channel from input low to ground. The value of the resistor may be in the range of 5k-100k, depending on the signal characteristics,

and should be determined empirically. These resistors can be mounted on headers which are plugged into the available resistor sockets on the AIM3A.

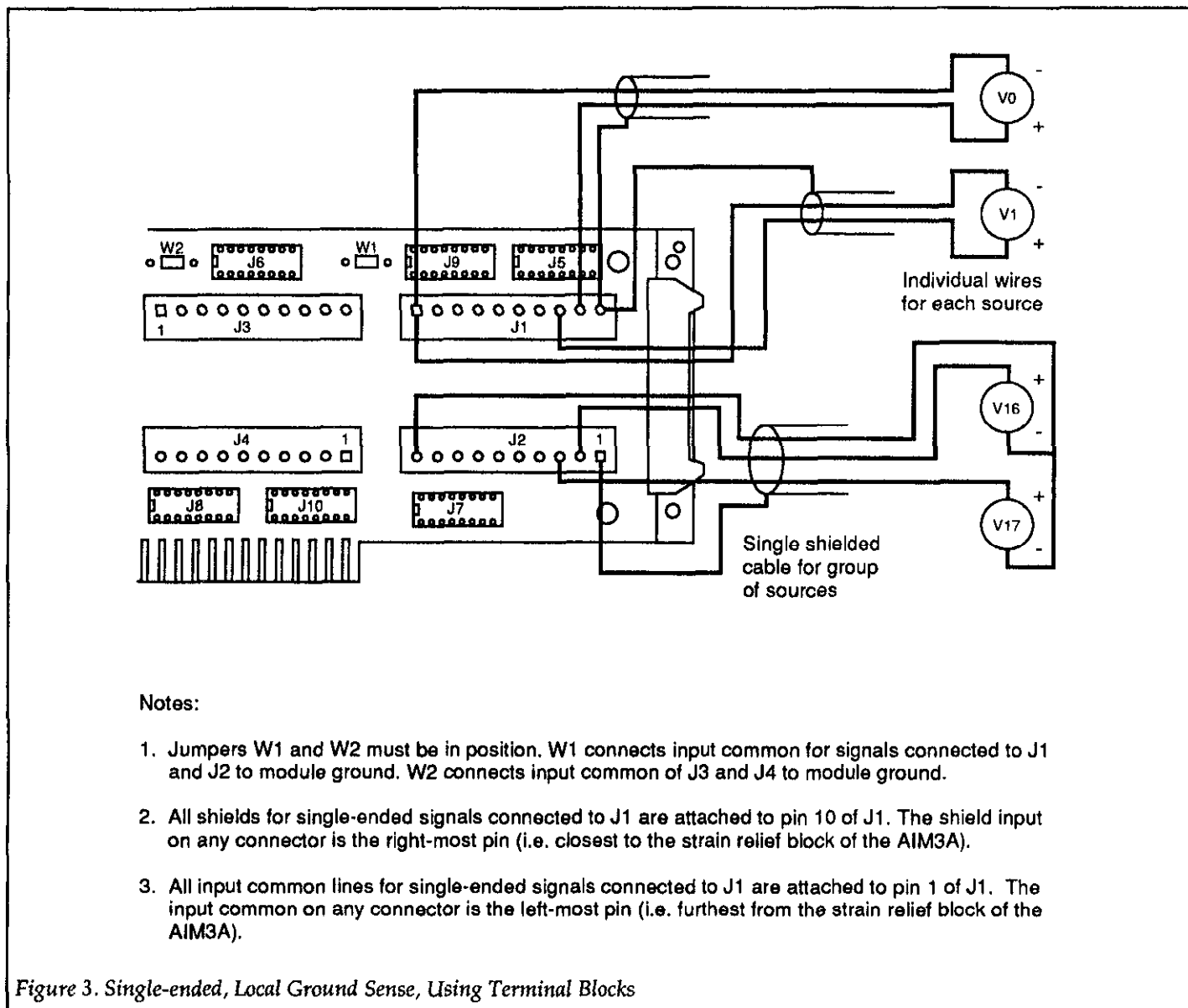

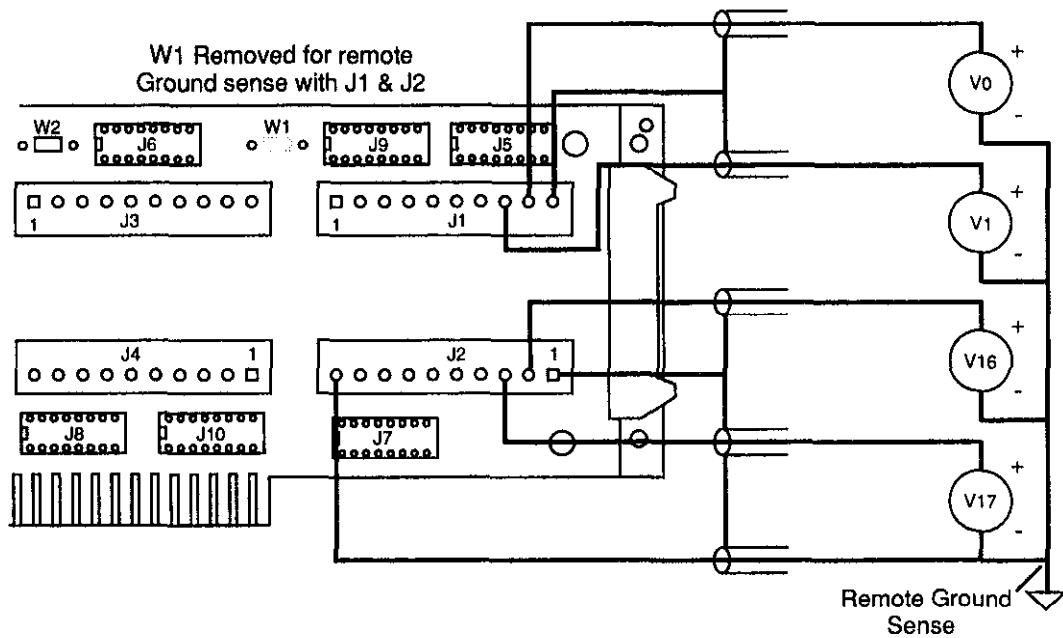

Notes:

1. Jumpers W1 and or W2 must be removed for this mode of operation: Remove W1 if connections J1 and J2 are used, or W2 if J3 or J4 are used.
2. The input common on any connector is the left-most pin (i.e. furthest from the strain relief block of the AIM3A).
3. The shield input on any connector is the right-most pin (i.e. closest to the strain relief block of the AIM3A).

Figure 4. Single-ended, Remote Ground Sense, Using Terminals

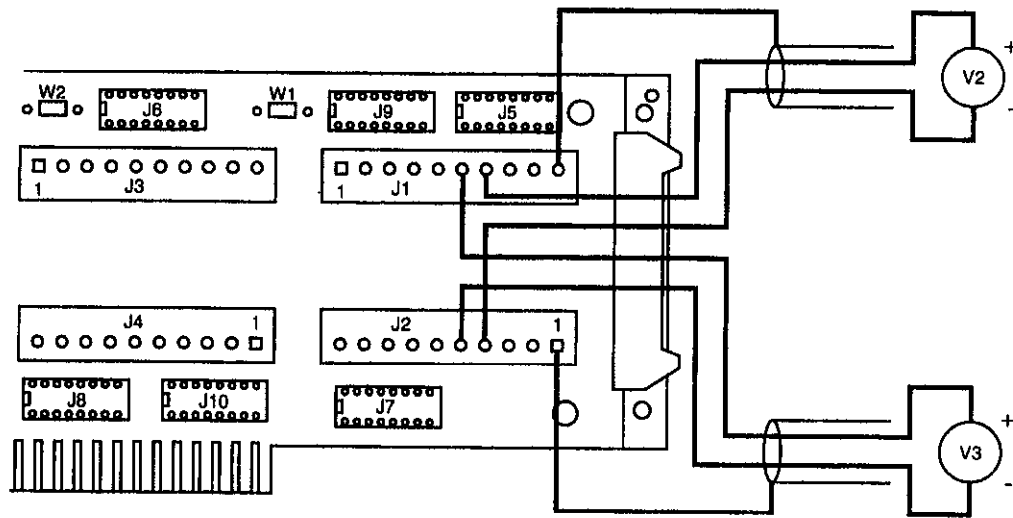

Notes:

1. Jumpers W1 and or W2 may be in or out for this setup.
2. Input Common terminals have no effect for differential measurements.
3. The input common on any connector is the left-most pin (i.e. furthest from the strain relief block of the AIM3A).
4. The shield input on any connector is the right-most pin (i.e. closest to the strain relief block of the AIM3A).

Figure 5. Differential Inputs, Using Terminal Blocks

Single-ended Inputs, Using Mass-termination

A location is provided near the strain relief block of the AIM3A module for an optional mass termination connector J11. Connector J11 has its pins wired in parallel with the connections on J1 and J2, and provides a method for quickly connecting up to 16 single-ended or 8 differential signals to the AIM3A. The pin out of J11 is identical to that of the Analog Devices 3B subsystem connector. When J11 is used, the remaining input terminals on J3 and J4 of the AIM3A may still be used in the usual fashion.

The pin out of J11 when used for single-ended inputs is shown in Figure 6. The pin out of J11 when used with differential inputs is shown in Figure 7. All the input signal connections previously described in Figures 3, 4, and 5 can be implemented with J11. When J11 is used with the Analog Devices 3B subsystem, the single-ended input with remote ground sensing configuration is used, and W1 must be removed.

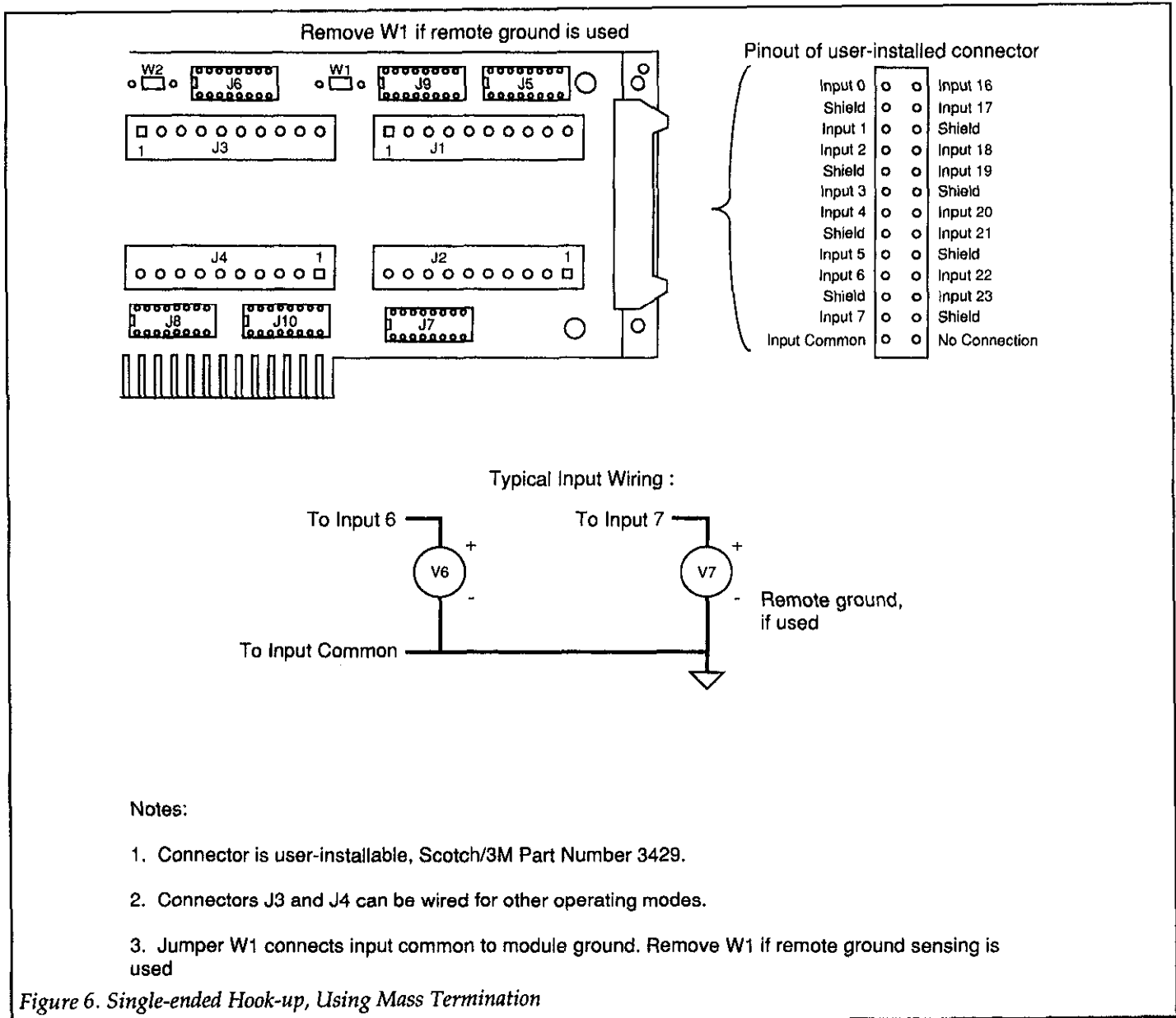

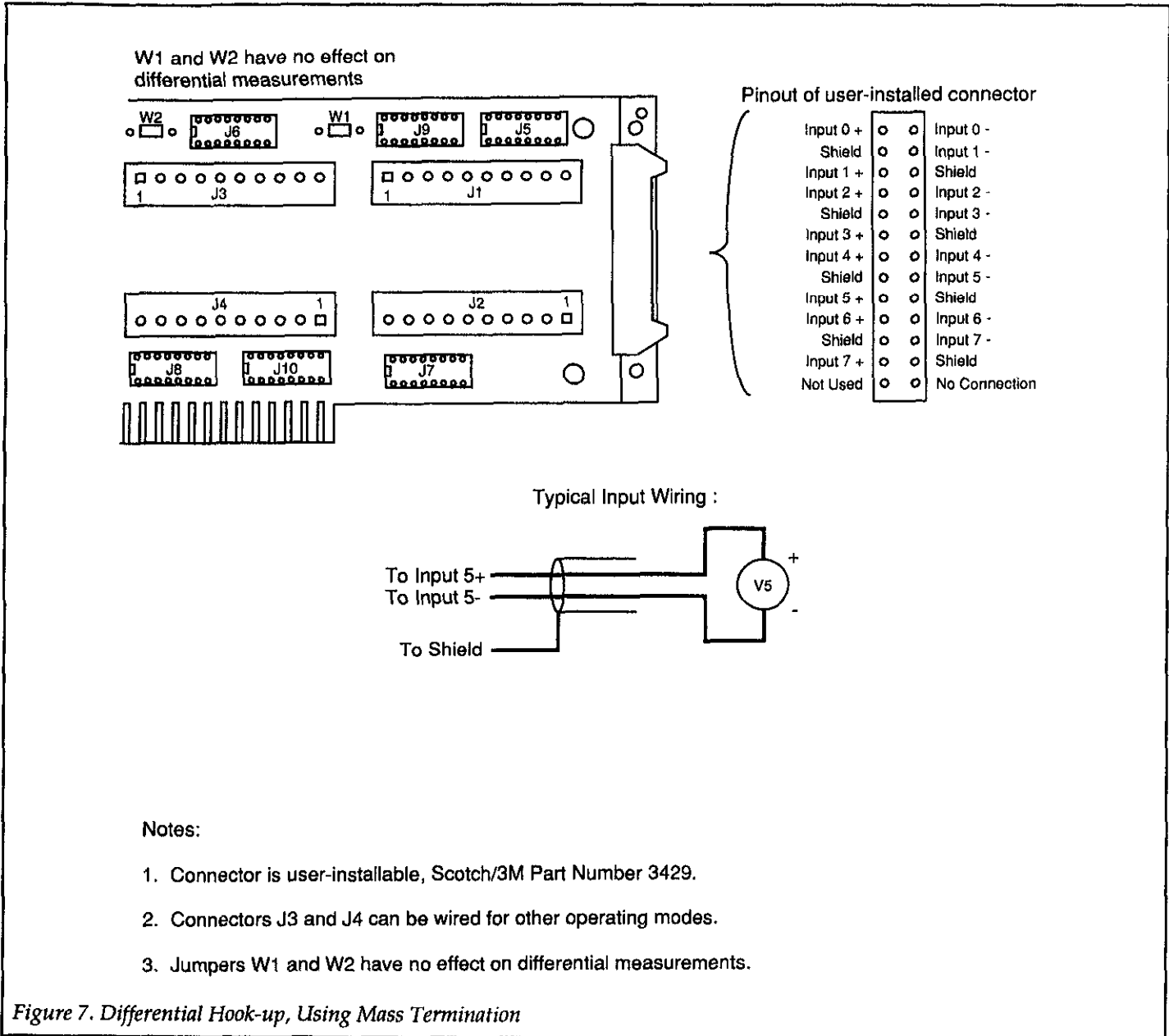

Current Measurement Using Terminal Blocks

The AIM3A can measure currents by using current sensing resistors to convert the current to a voltage. The voltage drop across the current sensing resistor may then be measured and converted to a current. DIP sockets and DIP headers are provided on the AIM3A to mount the current sensing resistors. If all the currents being measured have a common return path, the connection method shown in Figure 8 can be used. If the currents being measured have different return paths, the connection method shown in Figure 9 must be used. In both connection methods, the

common mode voltage limitation applies as described before; that is, no input terminal can be more than 10 volts positive or negative with respect to the module ground.

The example in Figure 8 shows two 4-20 ma current loop sensors being connected to single-ended channels 0 and 1. An external power supply is needed to power the sensors. Up to 16 current loop sensors can be connected to J1 and J2 and use the common current return path as shown. 16 additional current loop sensors can be wired to J3 and J4, and use the second common current return path. When the

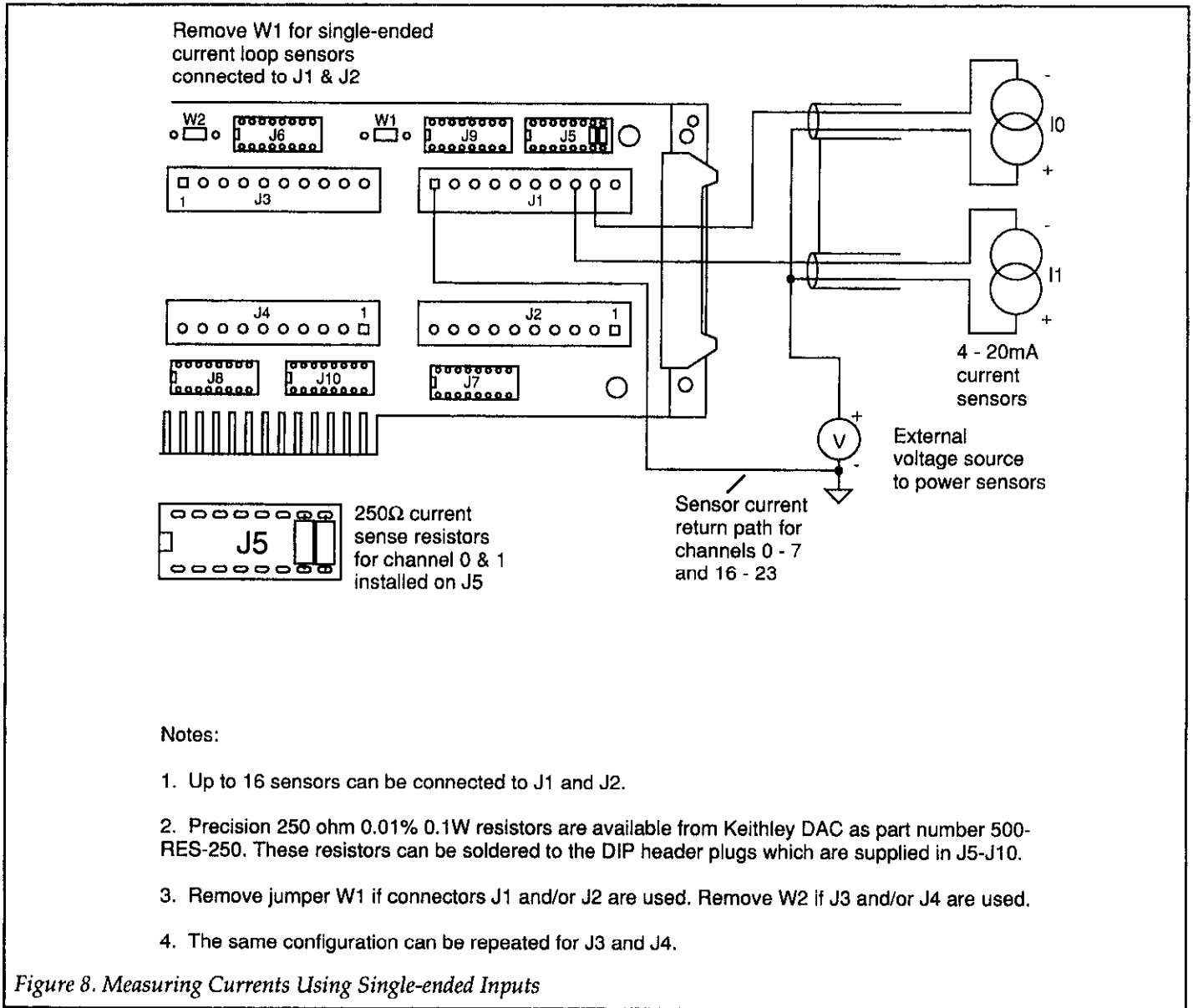

common current return is used as shown for single-ended current inputs, single-ended voltage inputs in that group of 16 cannot be used. Figure 9 shows a single 4-20 ma sensor connected up for current sensing in the differential mode. In this connection method, either input terminal on the AIM3A may be connected to ground either at the external power supply or at the sensor.

The resistor value used for current measurements should be chosen such that the resulting voltage drop does not exceed the voltage input range for the channel being used. Thus, if a maximum current of 20 mA is expected, and if the input range is $\pm 10V$, the resistor cannot be any larger than

500Ω or the resulting input voltage will be greater than 10V. Ohm's Law can be used to calculate the value as follows:

Voltage drop = maximum expected current \times resistor value

Generally, you may choose any resistor value which gives a suitable voltage drop. To avoid heating which may affect measurement accuracy, make sure the maximum power dissipated in the resistor is well within the power rating of the resistor. Calculate this dissipation with another Ohm's law equation,

$$P=I^2 \times R$$

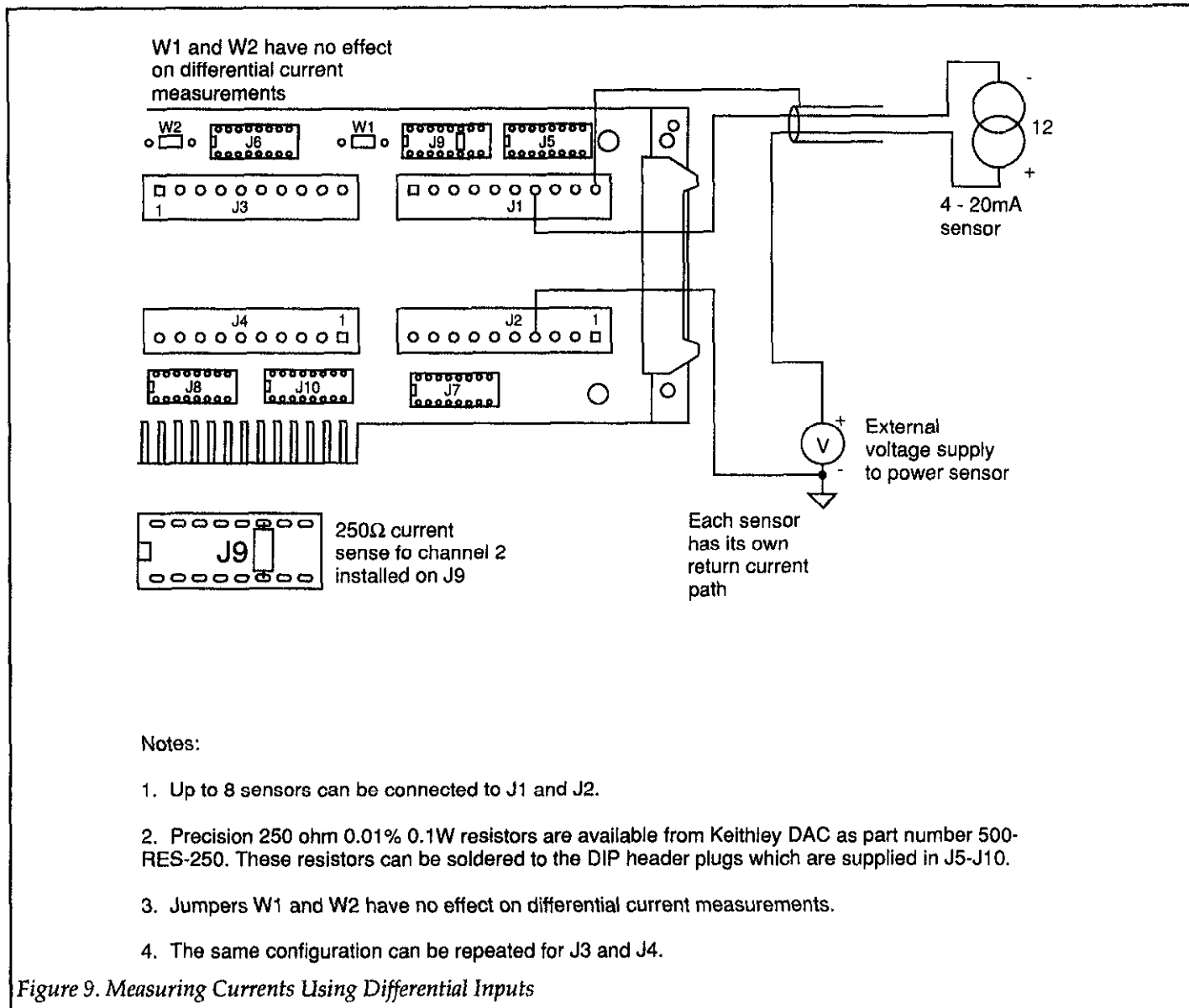

There is one case where you must install a specific value resistor. Keithley's software includes an engineering units flag which facilitates measurement of 4-20mA current loops. This EUF returns a reading of current in milliamps. It equates 4mA as 1V measured across the resistor, and 20mA as 5V. Ohm's law requires a resistor value of 250 ohms for this relationship to hold. Single-ended or differential mode can be used. Resistors with a value of 250 ohms @ 0.01% are available from DALE resistors; part number RN55E2500B, or from Keithley in packs of eight resistors as 500-RES-250.

Grounding

Care must be taken in wiring test circuits to minimize errors due to the resistance of connection wire, especially where the wire must carry an appreciable current. Figure 10 shows a circuit which has an inherent problem resulting in a measurement error of 26%. The 1.28 ohm and 50 ohm resistors are not actually discrete resistors in the circuitry, but instead represent the equivalent resistances of wire or other components. Figure 11 shows how the jumper W1 may be removed to overcome this measurement problem.

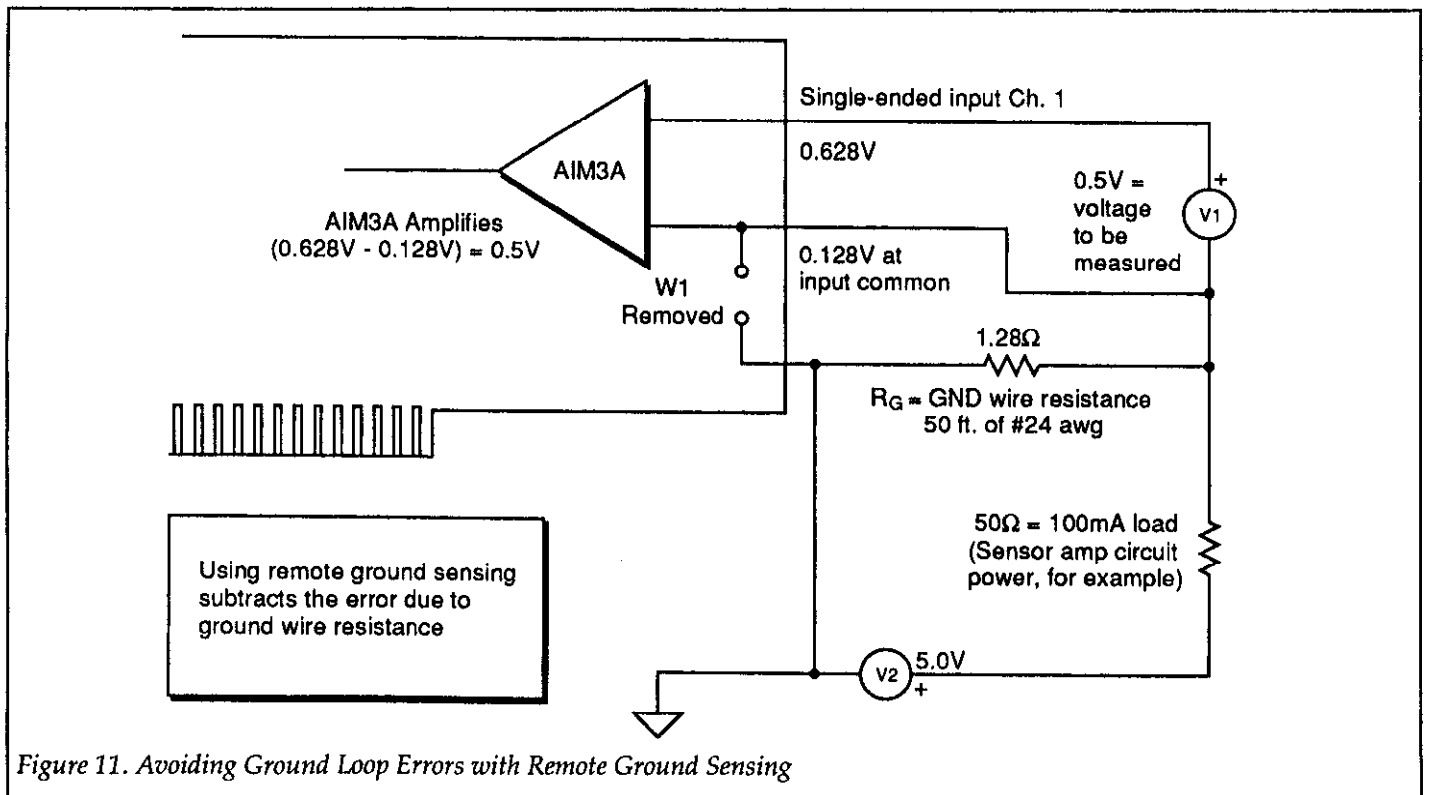
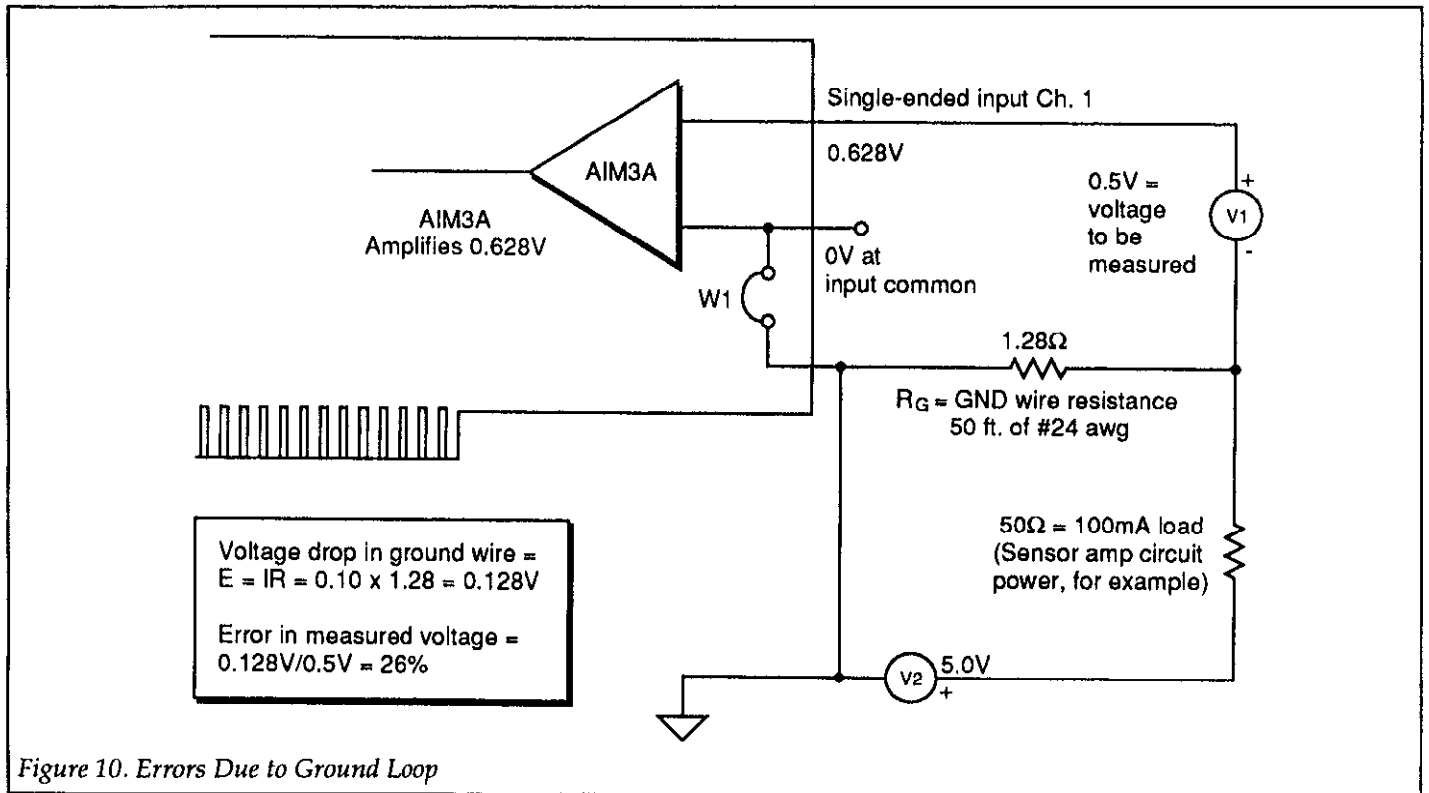

Selecting gains

The AIM3A module must be used with a data acquisition system containing an AMM1A, AMM2, or other A/D module. All Keithley master analog and A/D modules also include a programmable gain ("global") amplifier which can be used to amplify any analog signal before it is digitized by the A/D converter. The AIM3A also has an on-board ("local") instrumentation amplifier which amplifies only those signals connected to the AIM3A. Thus, total gains of x1, x2, x5, x10, x20, x50, x100, x500, and x1000 can be applied to signals connected to the AIM3A. The following guidelines should be used in selecting gains:

1. Where possible, the amplifier on the AIM3A should be used. The AIM3A amplifier processes the signal before it passes through the remaining multiplexer and amplifier circuits, so the amount of noise which is amplified along with the signal will be minimized.
2. The maximum signal presented to the A/D converter as a result of all the applied gains cannot exceed the A/D converter range.

Input filtering

Some types of measurements may be susceptible to noise from the environment. Examples include measurement of high-impedance signals, or measurements performed near motors, SCR controllers, etc. You should routinely take care to minimize noise in your measurement setups. Typical steps include:

1. Use short cable runs and shielded connecting cables.
2. Properly use shielding. Only one differential signal should be carried in a shielded cable. The shield should be terminated only on one end of the cable; generally to a shield terminal on the AIM3A.
3. Minimize external sources of noise, re-orient equipment, or use a power outlet for the data acquisition system which is not shared by any other equipment.
4. Take several readings and average them. If the noise is random, it will be filtered out mathematically through averaging.
5. Use any filtration available in the data acquisition system. The AMM2 module includes a programmable filter with pass bands of 100kHz or 2kHz. The reading rate available with the 100kHz filter is 50kHz, while the reading rate available with the 2kHz filter is 1kHz.
6. Consider external conditioning or filtration. In some cases you may want to implement a filter directly at one

or more inputs of the AIM3A. A single-pole input filter may be easily constructed using one resistor and one capacitor (see Figure 12). The relative RC values will depend on a variety of factors, including the frequency of the noise, the required attenuation, and the necessary response time. The RC values can be computed from the formula:

$$f_{(3db)} = \frac{1}{2\pi RC}$$

Where f is in Hz, C is farads, and R is ohms. The resulting system response time within 0.01% is then equal to $9.2 \times RC$.

As an example, assume that 10 counts of 60Hz noise is present in the signal. To reduce the noise to one count (i.e. to reduce the noise voltage by a factor of 10), an attenuator factor of 10 (20dB) will be necessary at 60Hz. A single-pole filter will roll off at a rate of 20dB per decade. Thus, a 3dB point of 6Hz would be chosen to attenuate to 60Hz noise by 20dB. Rearranging the above equation to solve for R we have:

$$R = \frac{1}{2\pi \times C \times f_{(3db)}}$$

Picking a nominal value of $0.5\mu\text{F}$ for C , the necessary resistance is:

$$R = \frac{1}{2\pi \times (0.5 \times 10^{-6}) \times 6}$$

$$R = 53,000 \text{ ohms}$$

The resulting response time (T_r) is:

$$T_r = 9.2 \times RC$$

$$T_r = 9.2 \times 53000 \times 0.5$$

$$T_r = 0.24\text{sec}$$

Note that there are a number of RC values that can be used in a given application. To minimize the effects of the series resistance, however, keep the value of R as low as possible.

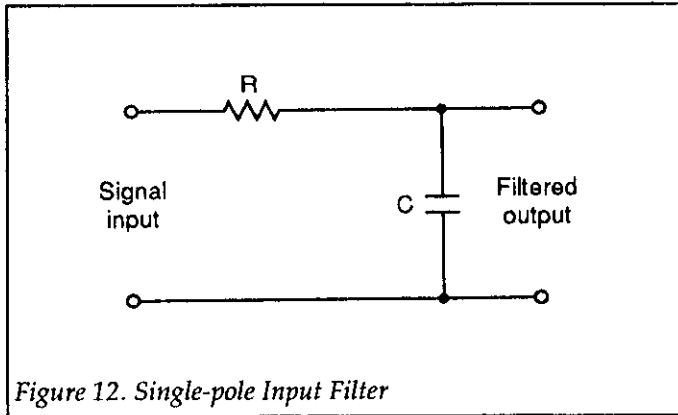

Figure 12. Single-pole Input Filter

High-Impedance Measurements

In measuring an analog signal, the measurement instrument places a small load on the signal and absorbs a small amount of current from the signal source. Ideally, this load should be zero, but will actually be some finite value. The input impedance of the AIM3A is 100 Megohms, which is comparable to a high-quality digital multimeter. Under most measurement situations, the AIM3A will present a negligible load to the signal source. However, measurement of signals from very high-impedance transducers such as pH meter electrodes requires input impedance several orders of magnitude higher.

Where signals of low to moderate impedance are mixed on one AIM3A, sufficient settling time or other measures must be taken to assure accurate measurements. When the AIM3A multiplexer selects any channel, a small charge flows into or out of the AIM3A. If the next channel selected by the multiplexer is a low impedance source, the AIM3A and source will rapidly settle for the next measurement. If the multiplexer instead switches to a high impedance signal source, more time will be required for the AIM3A input to settle at the new voltage.

Where high and low impedance signals are mixed on one AIM3A, it is thus important that sufficient settling time be provided per channel. It may also be helpful to short one AIM3A channel to ground, and to scan that channel between the actual signal channels. Alternately, an external buffer amplifier may be inserted between a high impedance signal and the AIM3A input. Such an amplifier presents a low impedance to the AIM3A, and may also be designed with some gain as well. A buffer amplifier can be built using an FET-input op amp and a few components. See an analog IC applications guide for more information.

User-Configured Components

The user-configurable components on the AIM3A are J5, J6, J7, J8, J9, J10, J11, W1 and W2.

Table 1. User-configured Components on the AIM3A Module

Component	Application
J5	Used for current sense resistors for single-ended inputs 0 through 7, or for ground reference resistors for differential (+) input channels 0 through 7.
J6	Used for current sense resistors for single-ended inputs 8 through 15, or for ground reference resistors for differential (+) input channels 8 through 15.
J7	Used for current sense resistors for single-ended inputs 16 through 23, or for ground reference resistors for differential (-) input channels 0 through 7.
J8	Used for current sense resistors for single-ended inputs 24 through 31, or for ground reference resistors for differential (-) input channels 8 through 15.
J9	Used for current sense resistors for differential inputs 0 through 7.
J10	Used for current sense resistors for differential inputs 8 through 15.
W1	Jumper which connects the input common of single-ended input channels 0 through 7 and 16 through 23 to module ground.
W2	Jumper which connects the input common of single-ended input channels 8 through 15 and 24 through 31 to module ground.

Table 2. Pin Outs for Single-ended Input Current Sense Resistors

Connector	Single-ended Channel	Differential Channel	Input Terminal	Input Common
J5	0	+0	8	9
J5	1	+1	7	10
J5	2	+2	6	11
J5	3	+3	5	12
J5	4	+4	4	13
J5	5	+5	3	14
J5	6	+6	2	15
J5	7	+7	1	16
J6	8	+8	8	9
J6	9	+9	7	10
J6	10	+10	6	11
J6	11	+11	5	12
J6	12	+12	4	13
J6	13	+13	3	14
J6	14	+14	2	15
J6	15	+15	1	16
J7	16	-0	9	8
J7	17	-1	10	7
J7	18	-2	11	6
J7	19	-3	12	5
J7	20	-4	13	4
J7	21	-5	14	3
J7	22	-6	15	2
J7	23	-7	16	1
J8	24	-8	9	8
J8	25	-9	10	7
J8	26	-10	11	6
J8	27	-11	12	5
J8	28	-12	13	4
J8	29	-13	14	3
J8	30	-14	15	2
J8	31	-15	16	1

Table 3. Pin Outs for Differential Current Sense Resistors

Connector	Differential Channel	(+) Input Terminal	(-) Input Terminal
J9	0	9	8
J9	1	10	7
J9	2	11	6
J9	3	12	5
J9	4	13	4
J9	5	14	3
J9	6	15	2
J9	7	16	1
J10	8	9	8
J10	9	10	7
J10	10	11	6
J10	11	12	5
J10	12	13	4
J10	13	14	3
J10	14	15	2
J10	15	16	1

Theory of Operation

The AIM3A circuitry is divided into three sections. The input multiplexer consists of U1, U2, U3, U4, and U5. The instrumentation amplifier consists of U6, U7, U8, and the associated resistors. The digital control logic consists of U9, U10, U11, U12, U13, and U14.

The programmable gain instrumentation amplifier is constructed using an AD625JN amplifier (U7). The inputs of U7 are connected to the input multiplexer through protection resistors R25 and R26. The output of U7 at pin 10 is connected to J12 pin 3. The ANA_COM signal at pins 2 and 43 of J12 is the system zero voltage reference point, grounded at the A/D converter input on the AMM1A or AMM2. U8 buffers this ground reference, and feeds the U7 ground reference input at pin 7.

U6 and resistors R11 through R24 form the programmable gain control for amplifier U7. Pins 5 and 12 of U7 drive the ends of a balanced voltage divider, and U6 selects two taps on the divider based on the gain setting programmed. The selected voltage divider taps are connected to U7 pins 2 and 15.

The input multiplexer allows either single-ended or differential signals to be selected as inputs to the instrumentation amplifier. When a differential input is selected, the (+) input of the selected channel is connected to the non-inverting input of the instrumentation amplifier by U1 (for channels 0 through 7) or U3 (for channels 8 through 15). The (-) input of the selected channel is routed through U2 (Ch 0-7) or U4 (Ch 8-15) to pin 14 of U5B. U5B is enabled, connecting the (-) input of the selected channel to the inverting input of the instrumentation amplifier. The 1K resistor networks R1, R2, R3, R4 combine with clamping diodes inside U1, U2, U3, U4 to provide input over voltage protection. The diodes are arranged to conduct whenever the input voltages either go above the +15 volt supply, or go below the -15 volt supply.

When a single-ended input is selected, one of the four input multiplexers, U1, U2, U3, or U4, connects the selected input to its output. U5A is enabled, so that the outputs of all four input multiplexers are connected to the non-inverting input of the instrumentation amplifier. If the selected input is on either J1 or J2, then U5C is enabled, connecting the inverting input of the instrumentation amplifier to input low reference connections on J1 and J2. If the selected input is on J3 or J4, then U5D is enabled, connecting the inverting

input of the instrumentation amplifier to input low reference connections on J3 and J4.

The digital control logic responds only to a write to CMDA. A write to CMDA occurs when CMDA and R/W are both pulsed low, causing U9D to pulse high. U14E inverts the output of U9D, and will cause U12 to latch the data on D0 through D4 at the trailing edge of the pulse. The input channel selection is controlled by these latched data bits, which are further decoded by U9A, U9B, U9C, U10A, U10B, U10C, U14A, and U14B. When a write pulse occurs, data is not latched by U11 if data bits D6 and D7 are both low at the time of the write pulse. This is accomplished by AND gate U10D, which combines the write pulse from U9D with the output of U13A. U13A is high if either D6 or D7 or both are high. When a write is allowed to U11, it latches data bits D5, D6, and D7. Latched data bit D5 selects single-ended or differential input mode by altering the decoding of the channel selection data bits D3 and D4 in

portions of U9 and U10. Latched data bits D6 and D7 switch the gain of the instrumentation amplifier by controlling U6.

AIM3A Commands and Command Locations

The AIM3A is controlled by writing to the Command A (CMDA) address for the slot in which the module is mounted. Programmable parameters include selection of channel, single-ended or differential mode, and gain. Command B is not implemented on the AIM3A, and there are also no READ modes for the AIM3A.

Keithley's KDAC500 software offers complete programmability of the AIM3A.

Table 4. AIM3A Command Locations and Functions

Read Functions:	
COMMAND	FUNCTION
CMDA	None
CMDB	None
Write Functions:	
COMMAND	FUNCTION
CMDA	Select channel, gain, and single-ended or differential input.
CMDB	None

Table 4. AIM3A Command Locations and Functions (Cont.)

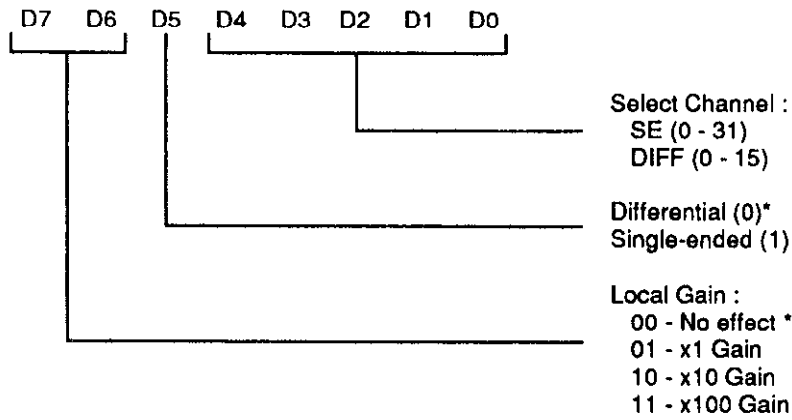
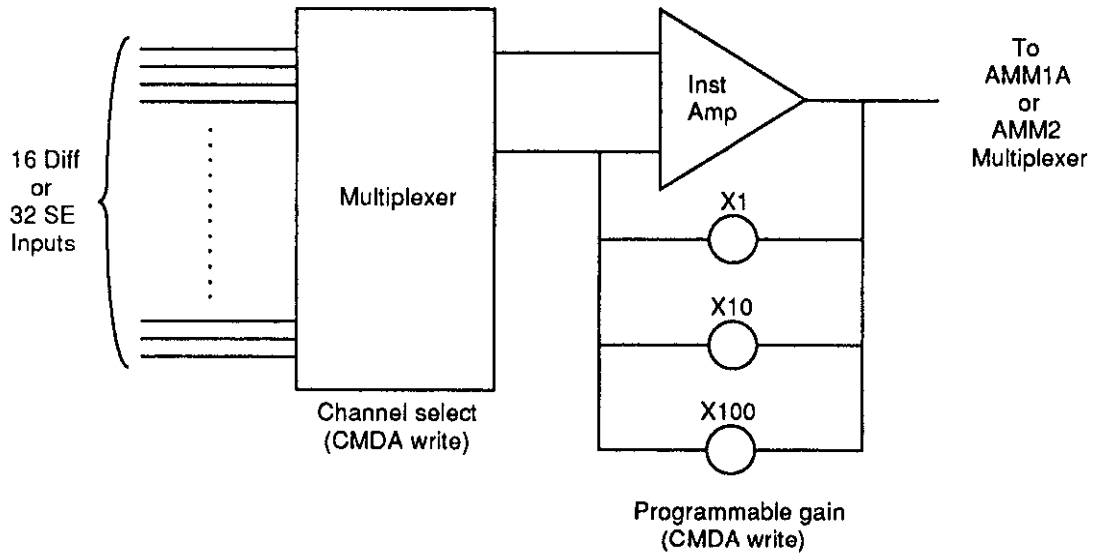

* A simultaneous write of 000 or 001 to bits D7, D6, and D5 will have no effect on the last write to D5, D6, or D7.

Calibration Procedure

There are four adjustments on the AIM3A: X10 gain, X100 gain, and two offset voltage adjustments. The offset adjustments can be made with equipment of average accuracy, whereas the gain adjustments require equipment meeting or exceeding the performance of the equipment specified for the procedures. The gain calibrations will degrade by a maximum of 0.01% per year. If the gains require readjustment, best results will be obtained if the module is returned for factory calibration.

Offset Adjustment

Equipment Required:

Keithley Model 196 DMM or equivalent
Keithley Model 500, 500A, or 575 Data Acquisition System

Procedure:

1. Install the AIM3A module to be calibrated in slot 3 of the Data Acquisition System. Install either an AMM1A or an AMM2 into slot 1 of the Data Acquisition System, then turn on the system power. Provide 15 minutes for the equipment to warm up.
2. Short single-ended channel 0 to ground by installing a jumper wire between pin 9 and pin 1 of input connector J1. If jumper W1 has been disconnected, it will also be necessary to also install a jumper wire between pin 1 and pin 10 of input connector J1 for this test.
3. Attach the (-) lead of the DMM to TP1 (labeled ANA COM) on the AIM3A. Attach the (+) lead of the DMM to TP2 (labeled ANA OUT) on the AIM3A. Select the most sensitive DC voltage range.
4. If U7, R27, or R28 have been replaced, preset R27 and R28 to near the center of their adjustment range by first rotating the adjustment screws counterclockwise at least 25 turns (or until a clicking sound is heard as the screw is rotated), and then rotating the adjustment screws clockwise 13 turns. R27 and R28 should not be preset if the board was functioning normally before this calibration was begun, since R27 and R28 are probably close to the proper adjustment.
5. Invoke BASICA on the computer controlling the data acquisition system. Using the BASICA direct mode, execute the following statement:

```
DEF SEG = &HCFF8
```

If the IBIN card in your system is set to an address other

than CFF8, use that address instead of CFF8 in the DEF SEG statement.

6. Using the BASICA immediate mode, execute the following statement:

```
POKE 4,96
```

This will select the X1 gain and single-ended channel 0.

7. Adjust R28 for a DMM indication of 0 volts, within 50 microvolts.
8. Using the BASICA immediate mode, execute the following statement:

```
POKE 4,224
```

This statement selects X100 gain and single-ended channel 0.

9. Adjust R27 for a DMM indication of 0 volts, within 500 microvolts.
10. Repeat steps 6, 7, 8, and 9 in order until no further improvement is obtained.

Gain Adjustment

Equipment Required:

Fluke Model 5101 Voltage Calibrator or equivalent
Keithley Model 196 DMM or equivalent
Keithley Model 500, 500A, or 575 Data Acquisition system

Procedure:

1. Install the AIM3A module to be calibrated in slot 3 of the Data Acquisition System. Install either an AMM1A or an AMM2 into slot 1 of the Data Acquisition System, then turn on the system power. Provide 15 minutes for the equipment to warm up.
2. Connect the (-) lead of the voltage calibrator output to J1 pin 1 and the (+) lead of the voltage calibrator output to J1 pin 9. If jumper W1 has been disconnected, it is necessary to also install a jumper wire between pin 1 and pin 10 of input connector J1 for this test.
3. Attach the (-) lead of the DMM to TP1 (labeled ANA COM) on the AIM3A, and the (+) lead of the DMM to TP2 (labeled ANA OUT) on the AIM3A. Select the most sensitive DC voltage range that can display a 10 volt reading.
4. Invoke BASICA on the computer controlling the data acquisition system. Using the BASICA immediate mode,

execute the following statement:

```
DEF SEG = &HCFF8
```

If the IBIN card in your system is set to an address other than CFF8, use that address instead of CFF8 in the DEF SEG statement.

5. Using the BASICA direct mode, execute the following statement:

```
POKE 4,160
```

This will select the X10 gain and single-ended channel 0.

6. With the voltage calibrator set to produce 0 volts output, note the offset voltage reading on the DMM.
7. Set the voltage calibrator to produce 1.0000 volts.
8. Adjust R21 for a DMM reading equal to 10 volts plus the offset voltage reading noted in step 6. When adding the offset reading, be sure to use the correct polarity.
9. Using the BASICA direct mode, execute the following statement:

```
POKE 4,224
```

This will select the X100 gain and single-ended channel 0.

10. With the voltage calibrator set to produce 0 volts output, note the offset voltage reading on the DMM.
11. Set the voltage calibrator to produce 100.00 millivolts.
12. Adjust R17 for a DMM reading equal to 10 volts plus the offset voltage reading noted in step 6. When adding the offset reading, be sure to use the correct polarity.

Troubleshooting

Any observed or suspected problem with a system or module may be the result of malfunctions in any part of the system. A hierarchy of possible problem areas is listed below. The list should help you apply an organized approach to troubleshooting, starting with software and working toward a specific module. It assumes that your system and software have both worked properly in the past. If you have spares, you can most quickly verify a system component through simple substitution. Check your data acquisition system manual or computer documentation — they may contain additional instructions on troubleshooting.

Faulty software or applications programs - If you have completed a new program which does not work as anticipated, review the program design and be certain that it actually functions as you assume. If a program which had been running properly begins to behave erratically, either the supporting software package or the application program may have been corrupted. This may occur through disk media failures, power supply problems, hardware failures, or operator error.

Compare your software package to a back-up copy or the original diskettes. If the software is questionable, you should reinstall the software from the original diskettes or known-good copies. Likewise, your applications program should be restored from backups if a problem develops.

Note that it is crucial to back up important software and programs. Ideally, you should make at least two copies, and store one in a location away from your work site. Application programs should be backed up regularly as they are being developed. Printouts of program listings may also be desirable.

Faulty computer system - A malfunctioning computer or peripheral can affect the data acquisition software and hardware, ranging from minor problems to total failure. These problems may be continuous or intermittent. If you suspect your computer, remove the data acquisition interface and run any diagnostics which came with the system to verify its performance. Also try running other software with which you are familiar. Pay close attention for any erratic behavior of the software which points to hardware problems.

Defective interface - A malfunctioning data acquisition interface can prevent the computer from booting up and operating properly, or it can affect only the data acquisition system. Some graphics, mouse, and networking adapters have been observed to conflict with data acquisition interfaces as a result of both using the same addresses or interrupts. The system operates properly with only one of the cards in place, but diagnostic error messages or other problems result with both cards plugged into the system. You can usually determine incompatibility by trying each suspected card individually, and then together in the system. Such incompatibility can often be overcome through switch settings, configuration changes, or minor modifications to the hardware.

Defective data acquisition interface cable - The cable carries essential power, control, or data signals. Open conductors in a cable will disrupt the process. Cable shorts, especially in lines carrying system power supply voltages, may cause a total shutdown of the computer or data acquisition mainframe. If these problems exist, try disconnecting the interface cable from the computer and data acquisition system.

There is a maximum permissible length specified for interface cables. Exceeding the length will also introduce problems. You may note erratic operation of the computer, corrupt data, or a failure of the indicator lamps on the data acquisition system to light.

Defective data acquisition mainframe - A mainframe defect can affect any and all data acquisition functions. Main areas of include the mother board logic and connectors, the expansion slots, and the power supply. In the case of a completely dead system, always check any fuses and cabling which carry power.

An individual slot may also be bad. A known good module can be tried in various slots to determine the condition of individual mainframe slots.

Defective module(s) in general - Failures in a module's address, data, or control circuitry can affect other modules if they ultimately reach the data acquisition mother board or power supply. You may be able to locate a faulty module by removing modules individually until the problem clears.

The master A/D module in slot 1 is a special case because it processes data from all analog input channels. Any analog input involves its global multiplexer, programmable gain amplifier, and A/D converter. If only the analog input functions are faulty, you should also consider the master A/D module. Use a known-good A/D module, or first verify your A/D module for proper operation before troubleshooting another analog module.

Analog output normally relies only on circuitry within an analog output module unless documentation for the module states otherwise.

Digital input and output are also performed wholly on a single module, with the exception of the PIM1 and PIM2

power control modules. The PIM modules use an external board and solid state relays. These should also be considered in situations where PIM modules are suspected of being faulty.

In troubleshooting modules, use a software package with which you are familiar to write a few simple test programs for the suspected module. Elaborate programs should generally not be used. They may contain their own errors which mask problems with hardware.

If a suspected module does not respond as expected, you may assume that the module requires calibration or is defective. If a module has no calibratable components, a problem at this point will normally indicate a failure within the module.

Defective AIM3A module - An AIM3A can be checked by running a few simple programs which test individual features of the module. If you suspect a noise problem, try shorting both inputs for a given channel to ground. The CMDA and CMDB registers can also be exercised to determine correct operation of the module. See information elsewhere in this manual.

A skilled technician who has access to electronic test equipment may be able to troubleshoot individual circuits on a module to isolate the faulty parts. A full parts list and diagram set are included with each module to aid the technician.

If a defective component is found, replacement parts may be obtained from Keithley. If factory service is desired, the module may be returned for repair. All Keithley-manufactured systems and modules are warranted against defects in material and workmanship for a period of one year. For information on replacement parts or factory service, see the Parts List section of the appropriate manual.

NOTE

If a calibratable module which had been working accurately suddenly becomes inaccurate by more than a few percent, the problem is more likely a malfunction and not a calibration problem. If you cannot calibrate the hardware after two attempts, you should return it to Keithley for repair or calibration at the factory.

Parts List

This section contains replacement parts information, component location drawings and schematic diagrams for the AIM3A module. Parts are listed alphanumerically in order of their circuit designations. You may obtain spares from Keithley Instruments, Inc., 28775 Aurora Road, Cleveland, OH 44139.

To place a parts order, or obtain information concerning replacement parts, first contact the Keithley customer service department at (216) 248-0400 X2725. When ordering parts, include the following information:

1. Model Number
2. Serial Number
3. Part Description
4. Circuit Designation (if applicable)
5. Keithley Part Number

If an additional instruction manual is required, order the manual package, Keithley Part Number 501-918-00. The manual package contains an instruction manual and any applicable addenda.

To place orders for additional AIM3A's or for any catalog part #, contact Sales Order Entry at 508-880-3000.

Table 5. Parts List - Model 500-AIM3A Analog Input Module

Part No.	Quantity	Title	Designation
C-365-.1	4	Cap, .1uF, 20%, 50V, Ceramic	C2, C3, C4, C5
C-64-100P	1	Cap, 100pF, 10%, 1000V, Ceramic	C1
CS-521-2	4	Conn, Strip, 10 Pin	J1, J2, J3, J4
CS-553	2	Conn, Test Point	TP1,TP2
IC-163	1	IC, Quad 2 Input NAND, 74LS00	U13
IC-179	1	IC, Quad 2 Input NOR, 74LS02	U9
IC-186	1	IC, Hex Inverter, 74LS04	U14
IC-203	1	IC, 18V OP-AMP, 308AW	U8
IC-215	1	IC, Quad 2 Input Pos AND, 74LS08	U10
IC-267	4	IC, 8 Ch CMOS Analog Multiplexer, 6108	U1, U2, U3, U4
IC-320	1	IC, SPST CMOS Analog Switch, DG211	U5
IC-366	1	IC, 4 Bit Bistable Latch, 74LS75	U11
IC-473	1	IC, 4 Chan Diff CMOS Analog Multi, 6208	U6
IC-679	1	IC, Programmable Gain Inst Amp, AD625JN	U7
IC-680	1	IC, HEX/Quad D Type Flip Flop, 74LS175	U12
J-3	2	Jumper, Circuit	W1, W2
R-176-1.09K	1	RES, 1.09K, .1%, 1/8W, Metal Film	R29
R-263-1.82K	2	RES, 1.82K, .1%, 1/10W, Metal Film	R13, R18
R-263-18.2K	2	RES, 18.2K, .1%, 1/10W, Metal Film	R12, R22
R-263-402	1	RES, 402, .1%, 1/10W, Metal Film	R14
R-76-1K	2	RES, 1K, 5%, 1/4W, Composition or Film	R5, R6
R-76-4.7K	4	RES, 4.7K, 5%, 1/4W, Composition or Film	R7, R8, R9, R10
R-76-6.8M	1	RES, 6.8M, 5%, 1/4W, Composition or Film	R23
R-88-1.5K	2	RES, 1.5K, 1%, 1/8W, Metal Film	R25, R26
R-88-10	1	RES, 10.5K, 1%, 1/8W, Metal Film	R16
R-88-182	1	RES, 182, 1%, 1/8W, Metal Film	R20
R-88-20K	2	RES, 20K, 1%, 1/8W, Metal Film	R11, R24
R-88-61.9K	1	RES, 61.9K, 1%, 1/8W, Metal Film	R19
R-88-69.8K	1	RES, 69.8K, 1%, 1/8W, Metal Film	R15
RP-89-10K	2	POT, 10K, 10%, .75W, Non-Wirewound	R27, R28
RP-89-200	2	POT, 200, 10%, .75W, Non-Wirewound	R17, R21
SO-65	6	16-Pin Socket	J5...J10
TF-177-1	4	RES Network, 1K, 2%, 2.25W	R1, R2, R3, R4
500-323	1	Cable Clamp Assy	
500-321	1	Cable Clamp	
500-322	1	Strip Rubber	
500-322	1	Strip Rubber	
6-32X1/2PPH	2	Screw	
501-918-00	1	Manual Package	

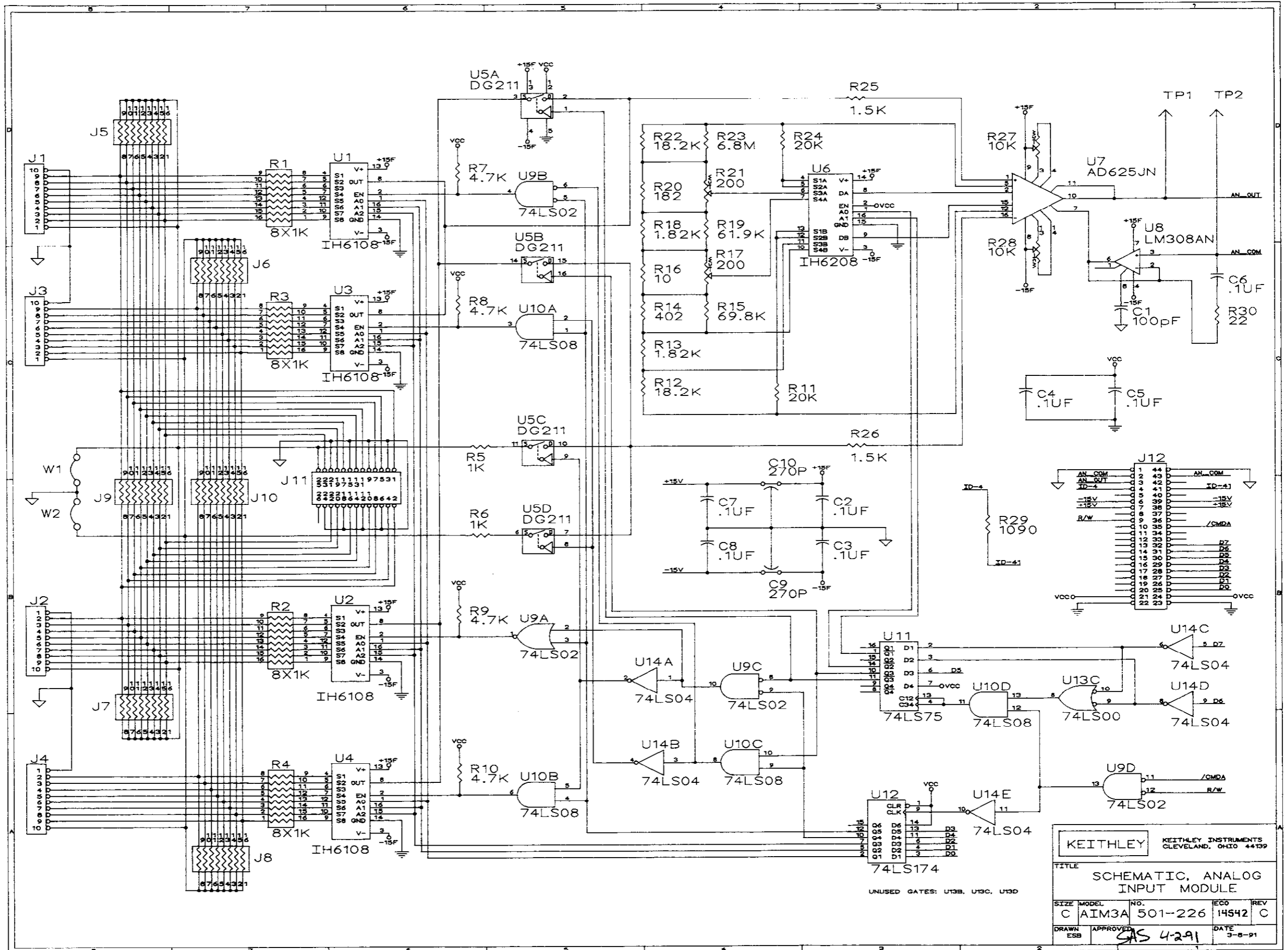

KEITHLEY KEITHLEY INSTRUMENTS
CLEVELAND, OHIO 44139

TITLE
SCHEMATIC, ANALOG
INPUT MODULE

SIZE	MODEL	NO.	ECO	REV
C	AIM3A	501-226	14542	C
DRAWN	APPROVED	DATE		
ESB	GAS 4-291	3-8-91		

UNUSED GATES: U13B, U13C, U13D

022-109 ON

A B C D E F G

1 2 3 4 5 6

UTR	ECO NO.	REVISION	ENG.	DATE
B		RELEASED	SAS	
C	14542	REVISED	SAS	4-3-91

OPTIONAL CONNECTOR INSTALLED BY USER

PLACE MC-285
SERIAL NO. LABEL
ON COMPONENT SIDE
OF BOARD IN THIS
LOCATION

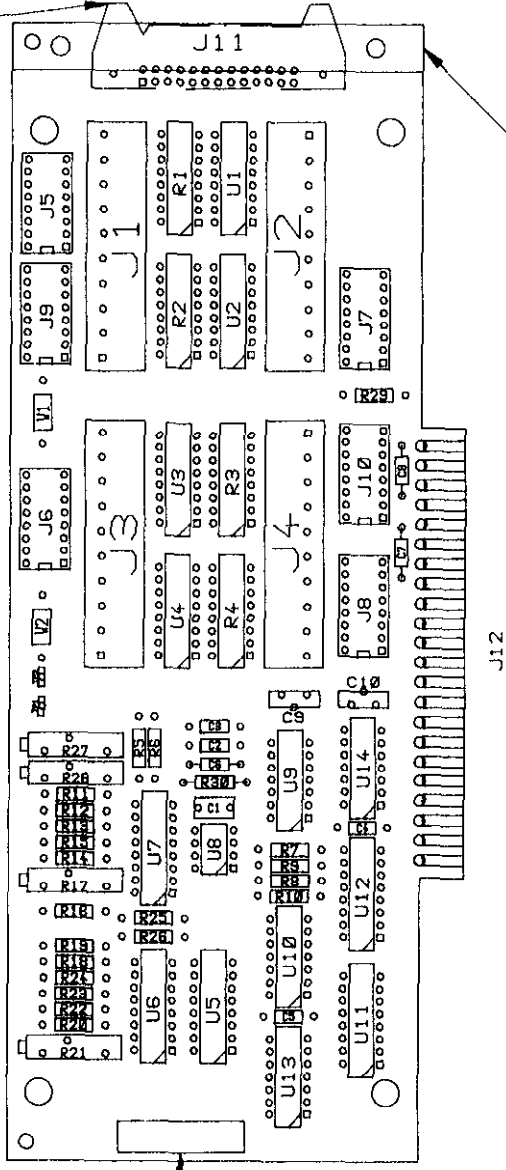

500-322
500-323
6-32 X 3/8 PPH (2 REQD)

NOTE:
FOR COMPONENT INFORMATION, REFER
TO BILL OF MATERIAL 500-AIM3A-00

MODEL	500-AIM3A	USED ON
NEXT ASSEMBLY		
QTY		

DATE	891214	SCALE	1:1	TITLE	COMPONENT LAYOUT, ANALOG INPUT MODULE
DRN.	SAS	ENG. APPR.	CSB		
MATERIAL	N/A				
FINISH	N/A				
				C	NO. 501-220

A B C D E F G

1 2 3 4 5 6