

# High Performance Current Transducer IT 600-S ULTRASTAB

$$I_{PM} = 0 \dots 600 \text{ A}$$

For the electronic measurement of currents: DC, AC, pulsed..., with galvanic isolation between the primary circuit and the secondary circuit.



## Electrical data

$I_{PN}$	Primary nominal current DC	600	A
$I_{PN}$	Primary nominal current rms	425	A
$I_{PM}$	Primary current, measuring range	0 .. $\pm 600$	A
$\hat{I}_p$	Max overload capability 100 ms <sup>1)</sup>	$\pm 3000$	A
$R_M$	Measuring resistance	$R_{M \min}$ $R_{M \max}$	
	Over operating current, temperature and supply voltage range	2.5 2.5	$\Omega$
$I_S$	Secondary current	0 .. $\pm 400$	mA
$I_{SN}$	Secondary nominal current rms	282	mA
$K_N$	Conversion ratio	1 : 1500	
$V_C$	Supply voltage ( $\pm 5\%$ )	$\pm 15$	V
$I_C$	Current consumption $\pm 15\text{ V}$	$\leq 200 + I_S$	mA

## Accuracy - Dynamic performance data

$\epsilon_L$	Linearity error <sup>2)</sup>	$\leq 1$	ppm
$I_{OE}$	Electrical offset current + self magnetization + effect of earth magnetic field @ $T_A = 25^\circ\text{C}$ <sup>2)</sup>	$< 20$	ppm
$\Delta I_{OE}$	Offset stability (no load) <sup>2)</sup>	$< 1$	ppm/month
$TCI_{OE}$	Temperature coefficient of $I_{OE}$ ( $10^\circ\text{C} \dots 50^\circ\text{C}$ ) <sup>2)</sup>	$< 0.2$	ppm/K
	Offset vs. power supply stability @ $T_A = 25^\circ\text{C}$ <sup>2)</sup> @ $V_C = \pm 15\text{ V} \pm 5\%$	$< 1.5$	ppm/% of $V_C = \pm 15\text{ V}$

## General data

$T_A$	Ambient operating temperature	10 .. + 50	$^\circ\text{C}$
	Humidity (non condensing)	20 - 80 %	RH
$T_S$	Ambient storage temperature	- 20 .. + 85	$^\circ\text{C}$
	Humidity (non condensing)	20 - 80 %	RH
$R_S$	Secondary coil resistance @ $T_A = 25^\circ\text{C}$	28	$\Omega$
$m$	Mass	1	kg

**Notes:** <sup>1)</sup> Single pulse only, not AC.

The transducer may requires a few seconds to return to normal operation when autoreset system is running.

<sup>2)</sup> All ppm figures refer to secondary measuring range 400 mA.

## Features

- Closed loop (compensated) current transducer using an extremely accurate zero flux detector
- Electrostatic shield between primary and secondary circuit.

## Special features

- 9-pin D-Sub male secondary connector
- Galvanically-isolated optocoupler output indicates transducer state.

## Advantages

- Very high accuracy
- Excellent linearity
- Extremely low temperature drift
- Wide frequency bandwidth
- High immunity to external electrostatic and magnetic fields interference
- No insertion losses
- High resolution
- Low noise on output signal
- Low noise reflected back onto primary conductor.

## Applications

- Feed back element in high performance gradient amplifiers for MRI
- Feed back element in precision current regulated devices (power supplies...)
- Calibration unit
- Precision and high-stability inverters
- Energy measurement
- Medical equipment.

## Application domain

- Industrial and Medical.

## Current Transducer IT 600-S ULTRASTAB

### Isolation characteristics

<b>V<sub>b</sub></b>	Rated isolation voltage rms, reinforced isolation	300	V
	Rated isolation voltage rms, single isolation	2000	V
with IEC 61010-1 standards and following conditions			
- Over voltage category III			
- Pollution degree 2			
<b>V<sub>d</sub></b>	Rms voltage for AC isolation test, 50/60 Hz, 1 min	4.9 <sup>1)</sup>	kV
<b>V̂<sub>w</sub></b>	Impulse withstand voltage 1.2/50 μs	9.1	kV
<b>V<sub>b</sub></b>	Rated isolation voltage rms, reinforced isolation	600	V
	Rated isolation voltage rms, single isolation	1000	V
with EN 50178 standards and following conditions			
- Over voltage category III			
- Pollution degree 2			
<b>dCp</b>	Creepage distance	10	mm
<b>dCI</b>	Clearance distance	10	mm
<b>CTI</b>	Comparative Tracking Index (Group I)	600	V

If isolated cable is used for the primary circuit, the voltage category could be improved with the following table (for single isolation) (IEC 61010-1 standard):

Cable isolated (primary)	Category
HAR03	2150 V CAT III
HAR05	2250 V CAT III
HAR07	2350 V CAT III

Note: <sup>1)</sup> Between primary and secondary + shield.

### Safety



This transducer must be used in electric/electronic equipment with respect to applicable standards and safety requirements in accordance with the manufacturer's operating instructions.



Caution, risk of electrical shock

When operating the transducer, certain parts of the module can carry hazardous voltage (eg. primary busbar, power supply).

Ignoring this warning can lead to injury and/or cause serious damage.

This transducer is a build-in device, whose conducting parts must be inaccessible after installation.

A protective housing or additional shield could be used.

Main supply must be able to be disconnected.

## Current Transducer IT 600-S ULTRASTAB

### Output noise figures: @ 25°C

Random Noise ppm (rms):

0 – 10 Hz	0 – 10 kHz	0 – 50 kHz
< 0.05	< 3	< 10

Re-injected noise measured on primary cable (DC - 50 kHz) < 10  $\mu\text{V}_{\text{RMS}}$

### Dynamic performance data

**BW** Frequency bandwidth for small signal 0.5 %, of  $I_{\text{PN}}(\text{DC})$  ( $\pm 3$  dB) DC .. > 100 kHz  
**di/dt** di/dt accurately followed > 100 A/ $\mu\text{s}$   
**t<sub>r</sub>** Response time <sup>1)</sup> to 90 % of  $I_{\text{PN}}$  step < 1  $\mu\text{s}$

Note: <sup>1)</sup> With a di/dt of 100 A/ $\mu\text{s}$ .

## Current Transducer IT 600-S ULTRASTAB

### Over current protection - Electrical specification - Status

As soon as electrical saturation appears, the transducer switches from normal operation to over current mode.

This electrical saturation appears in any case beyond 1.1 time the current range. The primary current corresponding to this trip level is related to the temperature inside the transducer.

Under these conditions:

- the contact (operation status) between pin 3 to 8 (of D-SUB-9 connector) switches off, this contact becomes open.
- Fault level (off state)  $I_P > 110\%$  of  $I_{PN}$  DC
- Max voltage pin 3 to pin 8, off-State 30 V
- Max current pin 3 to pin 8, on-State 6 mA
- Reverse voltage pin 3 to pin 8, off-State 6 V

To maintain safe start-up  $R_M$  must not exceed  $2.5\ \Omega$  during fault condition.

The over current mode remains until the primary current decreases to a value lower than the recovery current

### Max secondary current versus measuring resistor

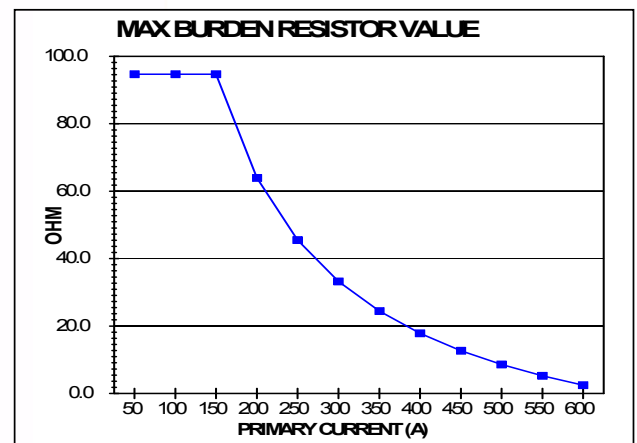
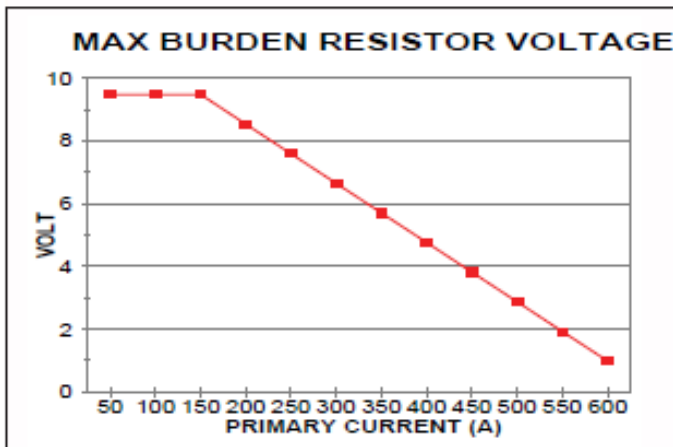

To maintain safe start-up  $R_M$  must not exceed  $2.5\ \Omega$  during fault condition.

### Miscellaneous

Bus bar free zone (length: 75 mm) (from center)  $r \geq 75$  mm

## Dimensions IT 600-S ULTRASTAB (in mm.)

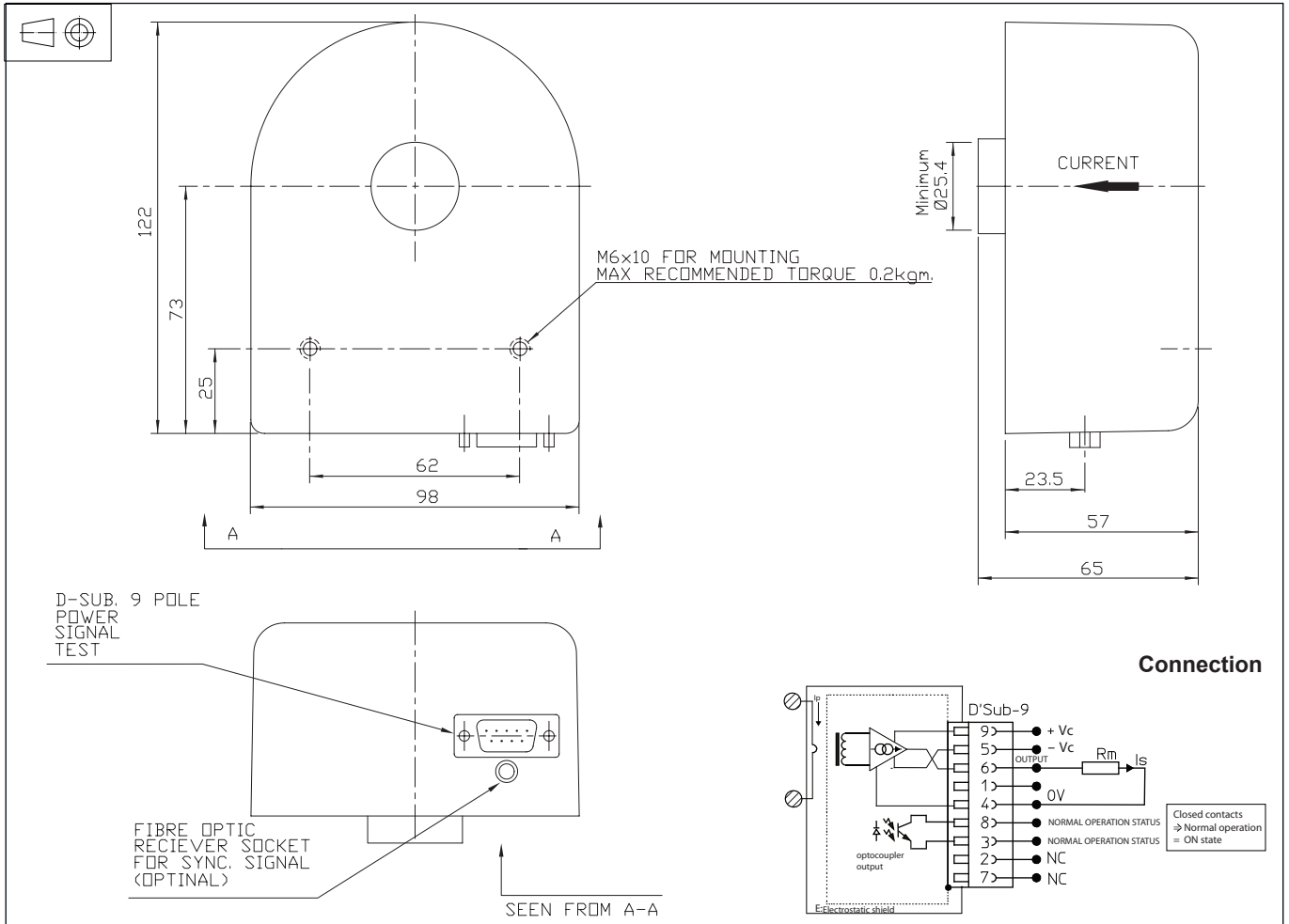

### Mechanical characteristics

- General tolerance  $\pm 0.3$  mm
- Transducer fastening
  - Flat mounting 2 x M6 x 10
  - Recommended fastening torque 1.96 Nm
- Connection of secondary connector on D-SUB-9, UNC 4-40
- Primary through hole  $\varnothing \leq 25.4$  mm

### Connection

- Normal operation status (Pins 3 to 8)  
Normal operation means:
    - $\pm 15$  V present
    - zero detector is working
    - compensation current  $\leq 110$  % of  $I_{PNDC}$
- The contacts of the related relay are closed under normal operation.

### Remarks

- $I_s$  is positive when  $I_p$  flows in the direction of the arrow.
- We recommend that a shielded output cable and plug are used to ensure the maximum immunity against electrostatic fields.
- Pin 4 should be connected to cable - and connector shield to maintain lowest output noise.
- Temperature of the primary conductor should not exceed 50°C.