

New Linear Regulators Solve Old Problems

Bob Dobkin, Vice President, Engineering and CTO, Linear Technology Corp.

Regulators regulate but are capable of doing much more. The architecture of linear regulators has remained virtually unchanged since the introduction of the three terminal floating voltage regulator in 1976. Regulators were either a floating architecture (LT[®]317) or else an amplifier loop with feedback from the output to the amplifier. Both of these architectures suffer from limitations on versatility, regulation and accuracy.

The feedback resistors set the output voltage and attenuate the feedback signal into the amplifier. Therefore the regulation at the output is a percentage of the output voltage, so higher output voltages have worse regulation in “Volts” while the percentage may be the same. Also, the bandwidth of the regulator changes with voltage. Since the loop gain is decreased, the bandwidth is decreased as well at higher output voltages. This makes transient response slower and ripple worse as output voltage goes up.

The regulator fixes current limiting and it has no adjustment. It is built into the IC and different devices must be used for different output currents. So, if the current limit needs to be matched to the application or accurate current limit is needed, an external circuit must be used. Figure 1a shows the basic architecture of older regulators.

A new architecture was introduced in 2007 in the LT3080. It used a current source for the reference and a voltage follower for the output amplifier. Two advantages of this architecture are the ability to parallel the regulators for more output current and the ability for the regulator to operate down to zero. Since the output amplifier always operates at unity gain, bandwidth is constant and regulation is constant as well. Transient response is independent of output voltage and regulation can be specified in millivolts rather than a percent of output. Figure 1b shows the new regulator architecture.

LT, LT, LTC, LTM, Linear Technology and the Linear logo are registered trademarks of Linear Technology Corporation. All other trademarks are the property of their respective owners.

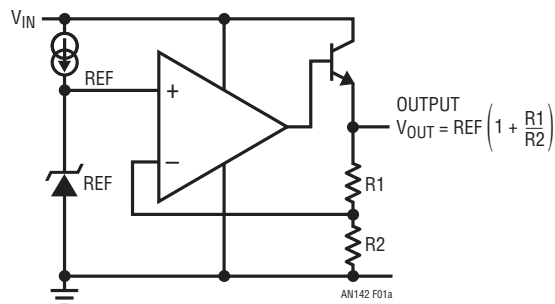

Figure 1a. Older Regulators

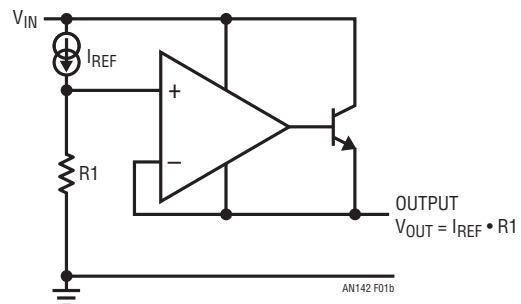

Figure 1b. New Architecture Regulator

Application Note 142

Table 1 shows the new regulators and main features. Along with different output current variations, these regulators were specifically designed to add functional features not previously available in existing regulators. There are monitor outputs for temperature, current and external control of current limit. One device (LT3086) also has external control of thermal shutdown. A new negative regulator provides monitoring and can operate as a floating regulator or an LDO. All of these new regulators can be paralleled for higher current, current sharing, and heat spreading.

A New Industrial Regulator

The LT3081 is a wide safe operating area industrial regulator. It provides 1.5A of output current, is adjustable to zero, is reverse protected and has monitor outputs for temperature and output current. In addition, the current limit can be adjusted by connecting an external resistor to the device. Figure 2 shows the basic hookup for the LT3081.

Temperature and current monitor outputs are current sources configured to operate from 0.4V above V_{OUT} to 40V below V_{OUT} . Temperature output is $1\mu A/^{\circ}C$ per degree and the current monitor is $I_{OUT}/5,000$. These current sources are measured by tying a resistor to ground in series with the current source and reading across the resistor. The current source has a range of $-40V$ to 0.4V referred to the output and it continues to work even if the output is shorted. The dynamic range for the monitor outputs is 400mV above the output so, with the output shorted or set to zero, temperature and current can still be measured. Using a 1k resistor provides sufficient margin and ensures operation when the output is shorted.

The output is set with a resistor from set pin to ground and a $50\mu A$ precision current source set to the output. The internal follower amplifier forces the output voltage to be the same voltage as the SET pin. Unique to the LT3081, an output capacitor is optional. The regulator is

Table 1

DEVICE	OUTPUT CURRENT	I_{SET}	ADJUSTABLE CURRENT LIMIT/CURRENT MONITOR	TEMPERATURE MONITOR	LDO	
LT3080	1.1A	$10\mu A$	No/No	No	Yes	
LT3081	1.5A	$50\mu A$	Yes/Yes	Yes	No	Output CAP Optional
LT3082	200mA	$10\mu A$	No/No	No	No	
LT3083	3A	$50\mu A$	No/No	No	Yes	
LT3085	600mA	$10\mu A$	No/No	No	Yes	
LT3086	2.1A		Yes/Yes	Yes + Temp Limit	Yes	
LT3090	600mA	$-50\mu A$	Yes/Yes	Yes	Yes	Negative Regulator
LT3092	200mA	$10\mu A$	No/No	No	No	Current Source Operation Needs No Output CAP

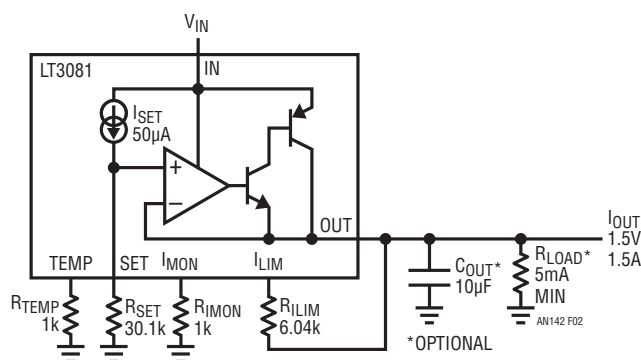

Figure 2. Basic Regulator Using the LT3081

stable with or without input and output capacitors. All the internal operating current flows through the output pin and minimum load is required to maintain regulation. Here, a 5mA load is required at all output voltages to maintain the device in full regulation.

The set resistor can add to the system temperature drift. Commercially available surface mount resistors have a wide range of temperature coefficients. Depending on the manufacturer, these can go from 100ppm up to over 500ppm. While the resistor is not heated by power dissipation in the regulator, over a wide ambient temperature range its temperature coefficient can change the output by 1 to 4 percent. Lower temperature coefficient thin film resistors are available for precision applications.

The benefit of using an internal true current source as the reference, rather than a bootstrapped reference, as in prior regulators, is not so obvious. A true reference current source allows the regulator to have gain and frequency

response independent of the impedance on the positive input. With all previous adjustable regulators, such as the LT1086, loop gain and bandwidth change with output voltage changes. If the adjustment pin is bypassed to ground, bandwidth also changes. For the LT3081, the loop gain is unchanged with output voltage or bypassing. Output regulation is not a fixed percentage of output voltage, but is a fixed number of millivolts. Use of a true current source allows all of the gain in the buffer amplifier to provide regulation, and none of that gain is needed to amplify up the reference to a higher output voltage.

Industrial applications require large safe operating area. Safe operating area is the ability to carry large currents at high input-output differentials. The safe operating area for several regulators is compared in Figure 3. The LT1086, introduced in the mid-1980s, is a 1.5A regulator in which output current drops very low above 20V input/output differential. Above 20V only about 100mA of output current is available. This causes output voltage to go unregulated if the load current is above 100mA and transients on the input cause the high voltage current limit to be exceeded. The LT1963A is a low dropout regulator that also has a limited safe operating area. The LT3081 extends the safe operating area, offering nearly 1A of output current at 25V of differential. Even above 25V, the output current of 500mA is still usable. This allows the regulator to be used in applications where widely varying input voltages can be applied during operation. Wide operating safe area is obtained by using a large structure for the PNP pass device. Also, The LT3081 is protected (along with the load) for reverse input voltage.

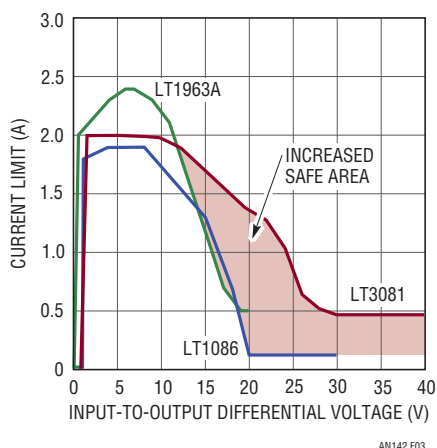

Figure 3. Comparative Safe Operating Area Performance

Figure 4 shows a block diagram of the LT3081. There are three current sources — two that report output current and

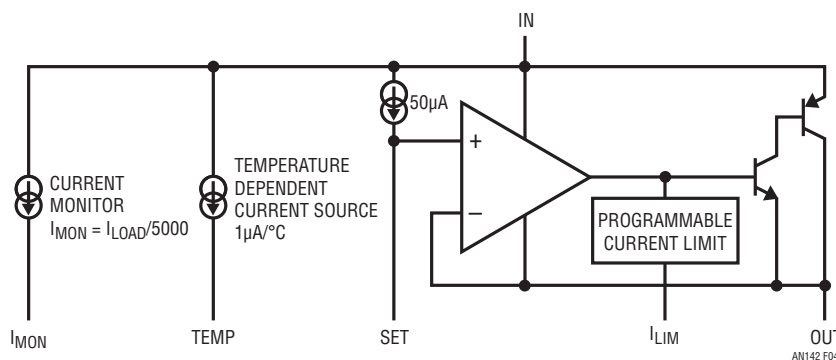

Figure 4. Block Diagram of the LT3081

Application Note 142

temperature. The third one supplies the 50 μ A reference current. The LT3081, while not a low dropout regulator, operates down to 1.2V across the device — slightly better than older devices such as the LT1086. The internal amplifier configuration, in conjunction with well-regulated internal bias supplies, allows the device to be stable with no external capacitors. One caveat: it cannot be designed to tolerate all possible impedances in the input and load, so it is important to test the stability in the actual system used. If instability is found, external capacitors will ensure that the device is stable at all output currents. External capacitors also improve the transient response since it is no longer limited by the bandwidth of the internal amplifier.

Paralleling devices, usually a forbidden application with previous regulators since they do not share current, is easy with these new current source reference regulators. Paralleling is useful for increasing output current or spreading the heat. Since it is set up as a voltage follower, tying all the set pins together makes the outputs the same voltage. If the outputs are at the same voltage, only a few milliohms of ballast are needed to ballast these devices and allow them to share current.

Figure 5 is a distribution of the offset voltage for the LT3081. The distribution is all within 1mV so to ensure sharing to 10%, 10m Ω of ballast resistance is more than sufficient. The ballast resistor can be less than an inch of a trace on a PC board or a small piece of wire, and provides good current balance from parallel devices. Even at 1V output, this degrades the regulation by only about 1.5%. Table 2 shows PC board resistance.

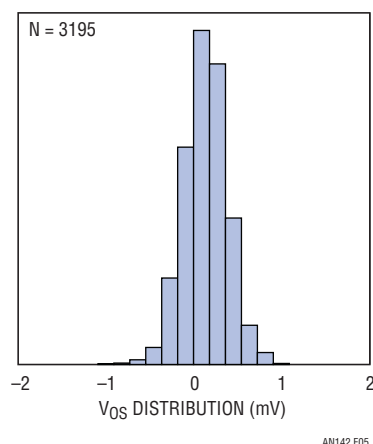

Figure 5. Offset Voltage

Table 2. PC Board Trace Resistance

WEIGHT (oz)	10mil WIDTH	20mil WIDTH
1	54.3	27.1
2	27.1	13.6

Trace resistance is measured in m Ω /in.

Figure 6 shows a schematic of two paralleled LT3081 devices to obtain 3A output. The set resistor now has twice the set current flowing through it, so the output is 100 μ A times R_{SET} and the 10m Ω output resistors ensure ballasting at full current. Any number of devices can be paralleled for higher current. The I_{LIM} pins can be paralleled (if used) so one resistor sets the current limit.

Figure 7 shows the LT3081 paralleled with a fixed regulator. This is useful when a system that has been designed has insufficient output current available. It provides a quick

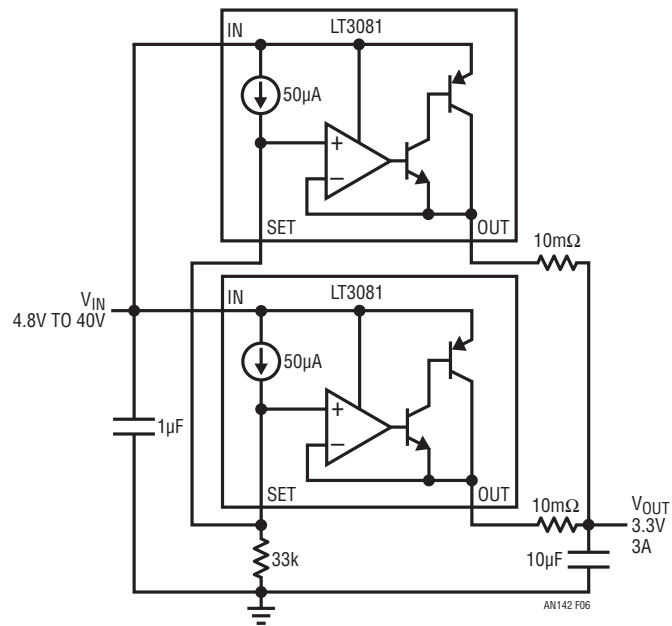

Figure 6. Paralleling Devices

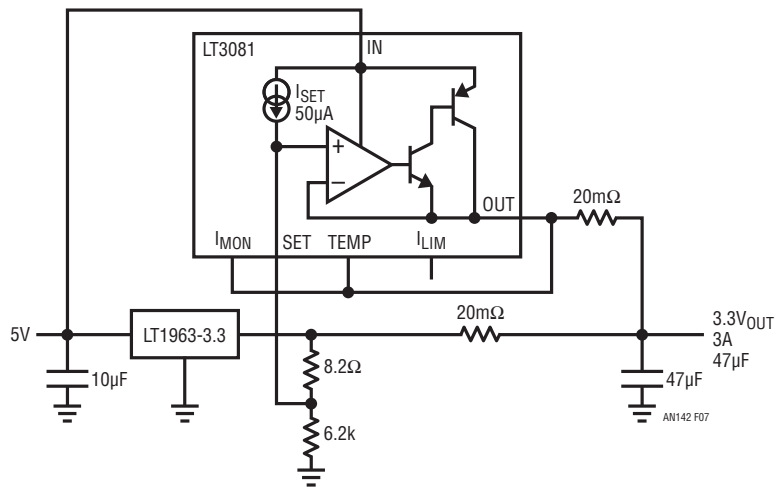

Figure 7. Increasing the Output Current of a Fixed Regulator

Application Note 142

fix for higher output current. The output voltage of the fixed device is divided down by just a few millivolts by the divider. The SET pin of the LT3081 is tied about 4mV below the fixed output. This ensures no current flows from the LT3081 under a no-load condition. Then the 20mΩ resistors provide sufficient ballast to overcome this offset and ensure current matching at higher output currents.

With the 50μA current source used to generate the reference voltage, leakage paths to or from the SET pin can create errors in the reference and output voltages. Cleaning of all insulating surfaces to remove fluxes and other residues is

required. Surface coating may be necessary to provide a moisture barrier in high humidity environments. Minimize board leakage by encircling the SET pin and circuitry with a guard ring tied to the OUT pin. Increasing the set current as shown also decreases the effects of spurious leakages.

The low 50μA SET current can cause problems in some applications. High value film potentiometers are not as stable as lower value wirewounds. Board leakage can also introduce instabilities in the output. Problems can be minimized by increasing the set current above the nominal 50μA. Figure 8 shows a solution using lower

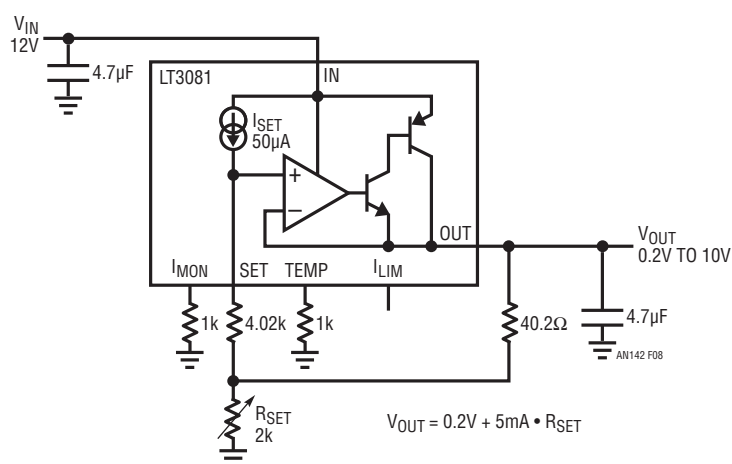

Figure 8. Using a Lower Value Set Resistor

value set resistors. Here an increased current is generated through R2 and summed with the set current, giving a much larger current for adjusting the output. Set current flows through a 4k resistor, generating 200mV across R1. Then the current through R2 adds to the set current, giving a total of 1.05mA flowing through I_{SET} to ground. This makes the voltage less sensitive to leakage currents around the R_{SET} . Care should be taken to Kelvin connect R2 directly to the output. Voltage drops from the output

to R2 will affect the regulation. Another configuration uses an LT3092 as an external current source of 1mA. This provides increased set current and allows the output to be adjusted down to zero.

Figure 9 shows an LT3092 current source used to provide the current reference to an LT3081. The 1mA generated reference current allows the adjustment set resistor to be much lower in value while still allowing the device to be adjusted down to zero.

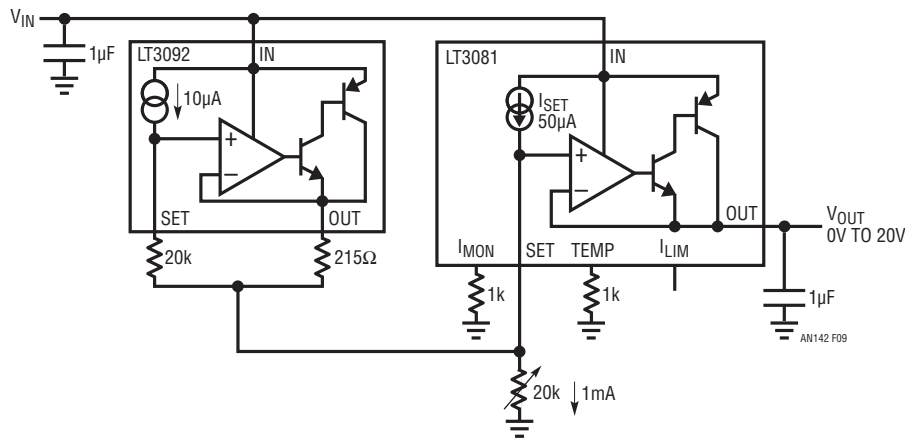

Figure 9. Using an External Reference Current

Application Note 142

The current monitor output can be used to compensate for line drops, as shown in Figure 10. Feeding the current monitor through a portion of the set resistor generates a voltage at the set pin that raises the output as a function of current. The value of the comp resistor is $R_2 = 5000 \cdot R_{\text{CABLE(TOTAL)}}$ and $V_{\text{OUT}} = 50\mu\text{A} (R_{\text{SET}} + R_{\text{COMP}})$. Several volts of line drop can be compensated this way.

Conclusion

New regulators provide an order of magnitude better regulation against load and line changes compared to prior

devices. Regulation specs as well as transient response do not change with output. New functionality in these devices provides temperature and current monitoring, as well as adjustable current limiting. Paralleling no longer requires external current balance circuitry to prevent current hogging. Along with these improvements comes ruggedness.

New applications are enabled. Paralleling is easy and line drops can be compensated. Current limit thresholds are now user defined and outputs are adjustable to zero. Safe operating area is increased for operation with wider input swings.

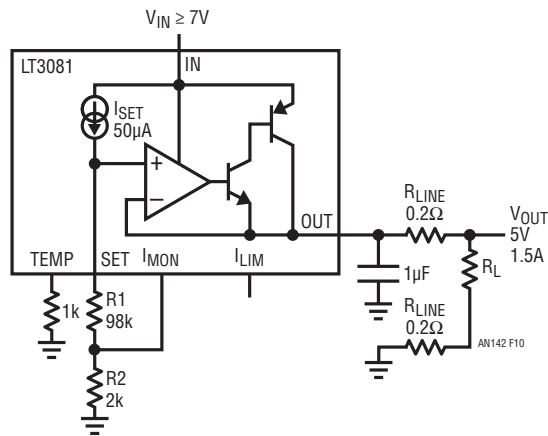

Figure 10. Using Current Monitor Output to Compensate for Line Drops