

## A Simple Method of Designing Multiple Order All Pole Bandpass Filters by Cascading 2nd Order Sections

Nello Sevastopoulos  
 Richard Markell

### INTRODUCTION

Filter design, be it active, passive, or switched capacitor, is traditionally a mathematically intensive pursuit. There are many architectures and design methods to choose from. Two methods of high order bandpass filter design are discussed herein. These methods allow the filter designer to simplify the mathematical design process and allow LTC's switched capacitor filters (LTC1059, 60, 61, 64) to be utilized as high quality bandpass filters.

The first method consists of the traditional cascading of non-identical 2nd order bandpass sections to form the familiar Butterworth and Chebyshev bandpass filters. The second method consists of cascading identical 2nd order bandpass sections. This approach, although "non-text-book," enables the hardware to be simple and the mathematics to be straightforward. Both methods will be described here.

AN27A is the first of a series of application notes from LTC concerning our universal filter family. Additional notes in the series will discuss notch, lowpass and highpass filters implemented with the universal switched capacitor filter. An addition to this note will extend the treatment of bandpass filters to the elliptic or Cauer forms.

This note will first present a finished design example and proceed to present the design methodology which relies on tabular simplification of traditional filter design techniques.

### DESIGNING BANDPASS FILTERS

Table 1 was developed to enable *anyone* to design Butterworth bandpass filters. We will discuss the tables in more detail later in this paper, but let's first design a filter.

#### EXAMPLE 1 — DESIGN

A 4th order 2kHz Butterworth bandpass filter with a  $-3\text{dB}$  bandwidth equal to 200Hz is required as shown in Figure 1.

Noting that  $(f_{\text{BP}}/\text{BW}) = 10/1$  we can go directly to Table 1 for our normalized center frequencies. From Table 1 under 4th order Butterworth bandpass filters, we go to  $(f_{\text{BP}}/\text{BW}) = 10$ .

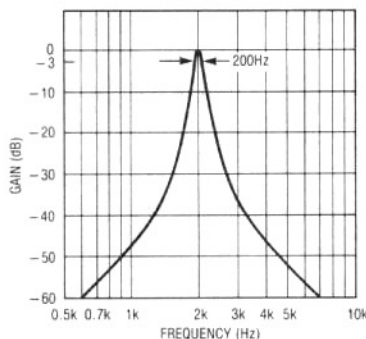

Figure 1. 4th Order Butterworth BP Filter,  $f_{\text{BP}} = 2\text{kHz}$

# Application Note 27A

We find  $f_{o1} = 0.965$  and  $f_{o2} = 1.036$  (both normalized to  $f_{oBP} = 1$ ). To find our desired actual center frequencies, we must multiply by  $f_{oBP} = 2\text{kHz}$  to obtain  $f_{o1} = 1.930\text{kHz}$  and  $f_{o2} = 2.072\text{kHz}$ .

The Q's are  $Q_1 = Q_2 = 14.2$  which is read directly from Table 1. Also available from the table is K which is the product of each individual bandpass gain  $H_{oBP}$ . To put it another way, the value of K is the gain required to make the gain, H, of the overall filter equal to 1 at  $f_{oBP}$ . Our filter parameters are highlighted in the following table:

$f_{oBP}$	$f_{o1}$	$f_{o2}$	Q's	K
2kHz	1.93kHz	2.072kHz	$Q_1 = Q_2 = 14.2$	2.03

## HARDWARE IMPLEMENTATION

Universal switched capacitor filters are simple to implement. A bandpass filter can be built from the traditional state-variable filter topology. Figure 2 shows this topology for both switched capacitor and active operational amplifier implementations. Our example requires four resistors for each 2nd order section. So eight resistors are required to build our filter.

We start with two 2nd order sections (1 LTC1060, 2/3 LTC1061 or 1/2 LTC1064), Figure 3.

We associate resistors as belonging to 2nd order sections, so R1x belongs to the x section. Thus R12, R22,

R33 and R42 all belong to the second of two 2nd order sections in our example.

Our requirements are shown in the following table:

SECTION 1	SECTION 2
$f_{o1} = 1.93\text{kHz}$	$f_{o2} = 2.072\text{kHz}$
$Q_1 = 14.2$	$Q_2 = 14.2$
$H_{oBP1} = 1$	$H_{oBP2} = 2.03$

Note that  $H_{oBP1} \times H_{oBP2} = K$  and this is the reason for choosing  $H_{oBP2} = 2.03$ .

For this example we choose the  $f_0 = \frac{f_{CLK}}{50} \sqrt{\frac{R_2}{R_4}}$  mode,

so we will tie the 50/100/Hold pin on the SCF chip to V+, generally (5V to 7V). We choose 100kHz as our clock and calculate resistor values. Choosing the nearest 1% resistor values we can implement the filter using Figure 3's topology and the resistor values listed below.

R11 = 147k	R12 = 71.5k
R21 = 10k	R22 = 10.7k
R31 = 147k	R32 = 147k
R41 = 10.7k	R42 = 10k

Our design is now complete. We have only to generate a TTL or CMOS compatible clock at 100kHz which we feed to the clock pin of the switched capacitor filter and we should be "on the air."

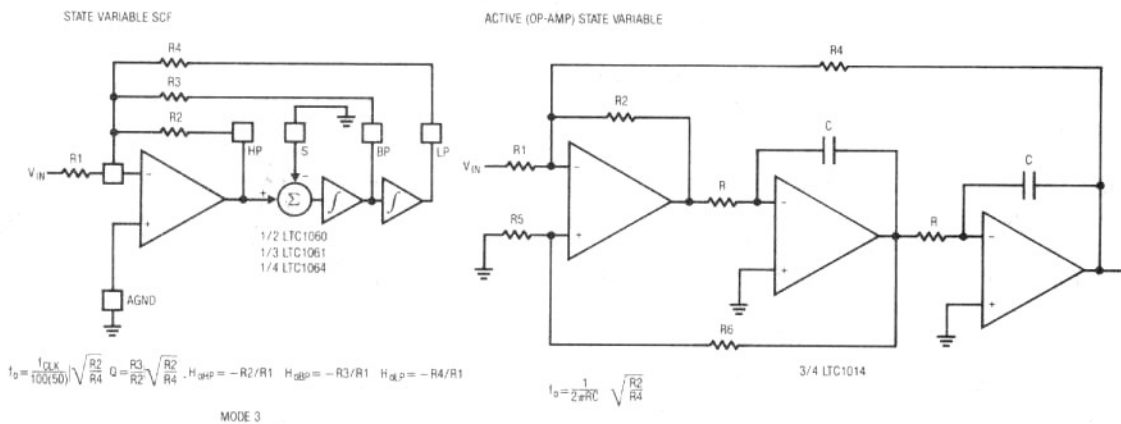

Figure 2. Switched Capacitor vs Active RC State Variable Topology

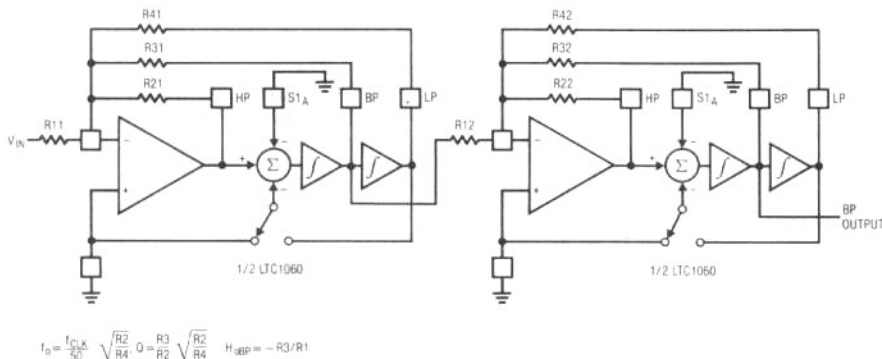

Figure 3. Two 2nd Order Sections Cascaded to Form 4th Order BP Filter

## DESIGNING BANDPASS FILTERS — THEORY BEHIND THE DESIGN

Traditionally, bandpass filters have been designed by laborious calculations requiring some time to complete. At the present time programs for various personal or laboratory computers are often used. In either case, no small amount of time and/or money is involved to evaluate, and later test, a filter design.

Many designers have inquired as to the feasibility of cascading 2nd order bandpass sections of relatively low Q to obtain more selective, higher Q, filters. This approach is ideally suited to the LTC family of switched capacitor filters (LTC1059, 1060, 1061 and 1064). The clock to center frequency ratio accuracy of a typical "Mode 1" design with non "A" parts is better than 1% in a design that simply requires three resistors of 1% tolerance or better. Also, no expensive high precision film capacitors are required as in the active op-amp state variable design.

We present here an approach for designing bandpass filters using the LTC1059, 1060, 1061 or the 1064 which many designers have "on the air" in days instead of weeks.

### CASCADING IDENTICAL 2ND ORDER BANDPASS SECTIONS

When we want to detect single frequency tones and simultaneously reject signals in close proximity, simple 2nd order bandpass filters often do the job. However, there are cases where a 2nd order section cannot be implemented

with the required characteristics (generally the Q's are too high). We wish to explore here the use of cascaded identical 2nd order sections for building high Q bandpass filters.

For a 2nd order bandpass filter:

$$Q = \frac{\sqrt{1-G^2}}{G} \times \frac{f/f_0}{|1-(f/f_0)^2|} \quad (1)$$

Where Q is the required filter quality factor

f is the frequency where the filter should have gain, G, expressed in Volts/V.

f<sub>0</sub> is the filter center frequency. Unity gain is assumed at f<sub>0</sub>.

### EXAMPLE 2 — DESIGN

We wish to design a 2nd order BP filter to pass 150Hz and to attenuate 60Hz by 50dB. The required Q may be calculated from Equation (1):

$$\text{So, } Q = \frac{\sqrt{1-(3.162 \times 10^{-3})^2}}{3.162 \times 10^{-3}} \times \frac{60/150}{|1-(60/150)^2|} = 150.7$$

This very high Q dictates a -3dB bandwidth of 1Hz.

Although the universal switched capacitor filters can realize such high Q's, their guaranteed center frequency accuracy of ±0.3%, although impressive, is not enough to

pass the 150Hz signal without gain error. According to the previous equation, the gain at 150Hz will be  $1 \pm 26\%$ ; the rejection, however, at 60Hz will remain at  $-50\text{dB}$ . The gain inaccuracy can be corrected by tuning resistor R4 when mode 3, Figure 2, is used. Also, if only detection of the signal is sought, the gain inaccuracy could be acceptable.

This high Q problem can be solved by cascading two identical 2nd order bandpass sections. To achieve a gain, G, at frequency f the required Q of each 2nd order section is:

$$Q = \frac{\sqrt{1-G}}{\sqrt{G}} \times \frac{f/f_0}{|1-(f/f_0)^2|} \quad (2)$$

The gain at each bandpass section is assumed unity.

In order to obtain 50dB attenuation at 60Hz, and still pass 150Hz, we will use two identical 2nd order sections.

We can calculate the required Q for each of two 2nd order sections from Equation (2):

$$\text{So, } Q = \frac{\sqrt{1-3.162 \times 10^{-3}}}{\sqrt{3.162 \times 10^{-3}}} \times \frac{60/150}{|1-(60/150)^2|} = 8.5!!$$

With two identical 2nd order sections each with a potential error in center frequency,  $f_0$ , of  $\pm 0.3\%$  the gain error at 150Hz is  $1 \pm 0.26\%$ . If lower cost (non "A" versions of LTC1060 and LTC1064) 2nd order bandpass sections are used with an  $f_0$  tolerance of  $\pm 0.8\%$ , the gain error at 150Hz is  $1 \pm 1.8\%$ ! The benefits of lower Q sections are therefore obvious.

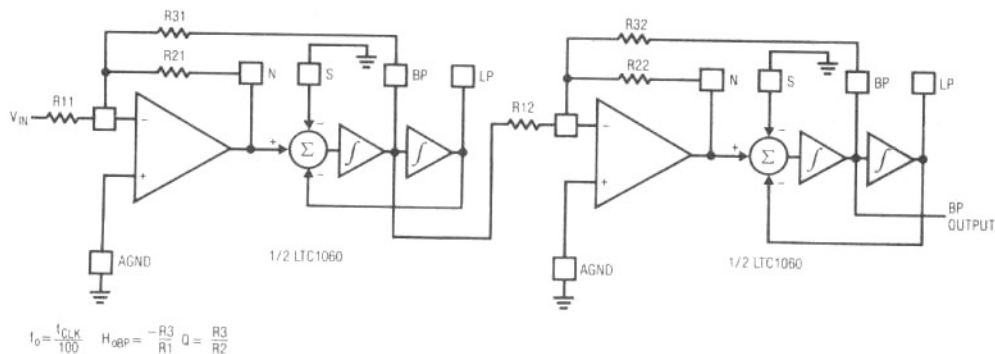

Figure 4. LTC1060 as BP Filter Operating in Mode 1

## HARDWARE IMPLEMENTATION

### Mode 1 Operation of LTC1060, 1061, 1064

As previously discussed, we associate resistors with each 2nd order section, so R1x belongs to x section. Thus R12, R22 and R23 belong to the second of the two 2nd order sections, Figure 4.

Each section has the same requirements as shown:

$$\begin{aligned} f_{01} &= f_{02} = 150\text{Hz} \\ Q_1 &= Q = 8.5 \\ H_{0\text{BP}1} &= H_{0\text{BP}2} = 1 \end{aligned}$$

Note that we could get gain out of our BP filter structure by letting the product of the  $H_{0\text{BP}}$  terms be  $> 1$  (within the performance limits of the filter itself).

For our example using the LTC1060 we will use  $f_{01} = f_{02} = f_{\text{CLK}}/100$ . So we input a 15kHz clock and tie the 50/100/Hold pin to mid-supplies (ground for  $\pm 5\text{V}$  supplies).

We can implement this filter using the two sections of an LTC1060 filter operated in mode 1. Mode 1 is the fastest operating mode of the switched capacitor filters. It provides Lowpass, Bandpass and Notch outputs.

Each 2nd order section will perform approximately as shown in Figure 5, curve (a).

Implementation in mode 1 is simple as only three resistors are required per section. Since we are cascading *identical* sections, the calculations are also simple.

We can calculate the resistor values from the indicated formulas and then choose 1% values. (Note that we let our minimum value be 20k.) The required values are:

$$\begin{aligned} R_{11} &= R_{12} = 169k \\ R_{21} &= R_{22} = 20k \\ R_{31} &= R_{32} = 169k \end{aligned}$$

Our design is complete. The performance of two 2nd order sections cascaded versus one 2nd order section is shown in Figure 5, curve (b). We must, however, generate a TTL or CMOS clock at 15kHz to operate the filter.

## Mode 2 Operation of LTC1060 Family

Suppose that we have no 15kHz clock source readily available. We can use what is referred to as mode 2, which allows the input clock frequency to be less than 50:1 or 100:1

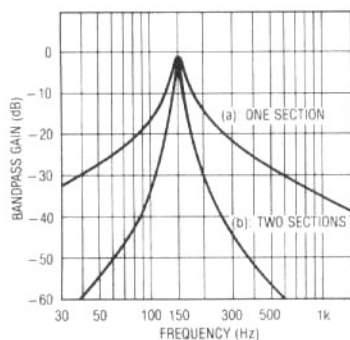

Figure 5. Cascading Two 2nd Order BP Sections for Higher Q Response

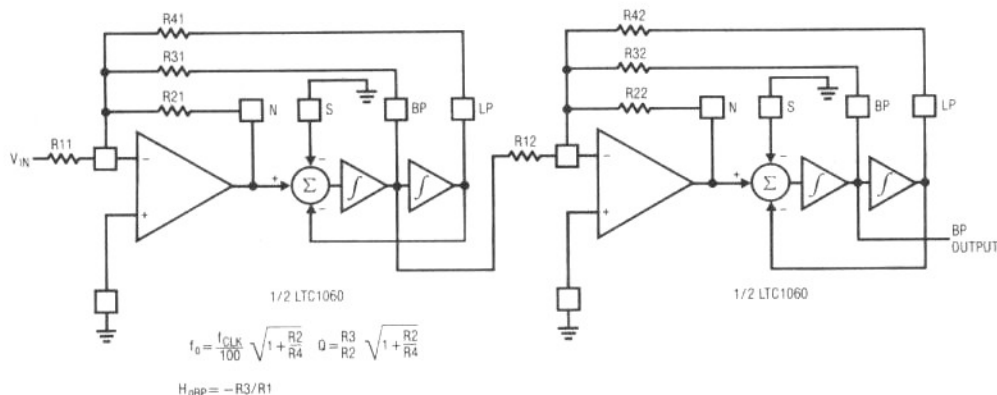

Figure 6. LTC1060 as BP Filter Operating in Mode 2

$[f_{CLK}/f_0 = 50 \text{ or } 100]$ . This still depends on the connection of the 50/100/Hold pin.

If we wish to operate our previous filter from a television crystal at 14.318MHz we could divide this frequency by 1000 to give us a clock of 14.318kHz. We could then set up our mode 2 filter as shown in Figure 6.

We can calculate the resistor values from the formulas shown and then choose 1% values. The required values are:

$$\begin{aligned} R_{11}, R_{12} &= 162k \\ R_{21}, R_{22} &= 20k \\ R_{31}, R_{32} &= 162k \\ R_{41}, R_{42} &= 205k \end{aligned}$$

## CASCADING MORE THAN TWO IDENTICAL 2ND ORDER BP SECTIONS

If more than two identical bandpass sections (2nd order) are cascaded, the required Q of each section may be shown to be:

$$Q = \frac{\sqrt{1 - G^{2/n}}}{G^{1/n}} \times \frac{(f/f_0)}{|1 - (f/f_0)^2|} \quad (3)$$

where Q, G, f and  $f_0$  are as previously defined and n = the number of cascaded 2nd order sections.

# Application Note 27A

The equivalent Q of the overall bandpass filter is then:

$$Q_{\text{equiv}} = \frac{Q_{(\text{identical section})}}{\sqrt{2^{1/n}} - 1} \quad (4)$$

Figure 7 shows the passband curves for Q=2 cascaded bandpass sections where n is the number of 2nd order sections cascaded.

The benefits can be seen for two and three cascaded sections. Cascading four or more sections increases the Q, but not as rapidly. Nevertheless for designers requiring high Q bandpass filters cascading identical sections is a very real option considering the simplicity.

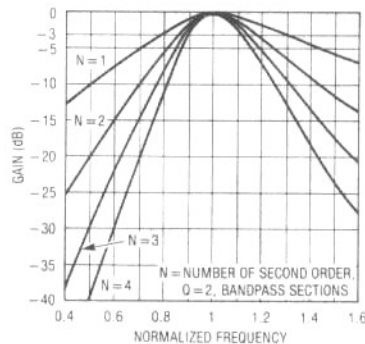

Figure 7. Frequency Response of n Cascaded Identical 2nd Order Bandpass Sections

## SIMPLE 2ND ORDER BANDPASS FILTERS

### Gain and Phase Relations

The bandpass output of each 2nd order filter section of the LTC1059, 60, 61, 64, closely approximates the gain and phase response of an ideal "textbook" filter.

$$G = \frac{(H_{\text{BP}}) \times (f_0/Q)}{[(f_0^2 - f^2)^2 + (ff_0/Q)^2]^{1/2}}$$

G = filter gain in Volts/V

$f_0$  = the filter's center frequency

Q = the quality coefficient of the filter

$H_{\text{BP}}$  = the maximum voltage gain of the filter occurring at  $f_0$

$\frac{f_0}{Q}$  = the -3dB bandwidth of the filter

Figure 8 illustrates the above definitions. Figure 9 illustrates the bandpass gain, G, for various values of Q. This figure is very useful for estimating the filter attenuation when several identical 2nd order bandpass filters are cascaded. High Q's make the filter more selective, and at the same time, more noisy and more difficult to realize. Q's in excess of 100 can be easily realized with the universal switched capacitor filters, LTC1059, 60, 61, 64, and still maintain low center frequency and Q drift, but for system considerations, this may not be practical.

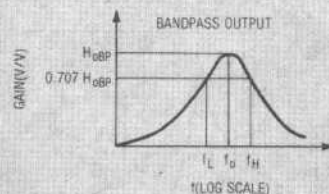

$$Q = \frac{f_0}{f_H - f_L} \quad f_0 = \sqrt{f_L f_H}$$

$$f_L = f_0 \left( \frac{-1}{2Q} + \sqrt{\left(\frac{1}{2Q}\right)^2 + 1} \right)$$

$$f_H = f_0 \left( \frac{1}{2Q} + \sqrt{\left(\frac{1}{2Q}\right)^2 + 1} \right)$$

Figure 8. Bandpass Filter Parameters

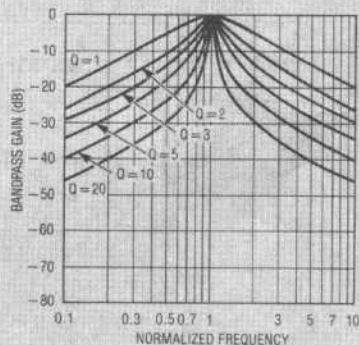

Figure 9. Bandpass Gain as a Function of Q

The phase shift,  $\phi$ , of a 2nd order bandpass filter is:

$$\phi = -\arctan \left[ \left( \frac{f_0^2 - f^2}{ff_0} \right) \times Q \right]$$

The phase shift at  $f_0$  is  $0^\circ$  or, if the filter is inverting, it is  $-180^\circ$ . All the bandpass outputs of the LTC1059, 60, 61 and LTC1064 universal filters are inverting. The phase shift, especially in the vicinity of  $f_0$ , depends on the value of  $Q$ , see Figure 10. By the same argument, the phase shift at a given frequency varies from device to device due to the  $f_0$  tolerance. This is true especially for high  $Q$ 's and in the vicinity of  $f_0$ . For instance, a LTC1059A, 2nd order universal filter, has a guaranteed initial center frequency tolerance of  $\pm 0.3\%$ . The ideal phase shift at the ideal  $f_0$  should be  $-180^\circ$ . With a  $Q$  of 20, and without trimming, the worst case phase shift at the ideal  $f_0$  will be  $-180^\circ \pm 6.8^\circ$ . With a  $Q$  of 5 the phase shift tolerance becomes  $-180^\circ \pm 1.7^\circ$ . These are important considerations when bandpass filters are used in multichannel systems where

phase matching is required. By way of comparison, a state variable active bandpass filter built with 1% resistors and 1% capacitors may have center frequency variation of  $\pm 2\%$  resulting in phase variations of  $\pm 38.8^\circ$  for  $Q=20$  and  $\pm 11.4^\circ$  for  $Q=5$ .

### Constant Q vs. Constant BW

The bandpass outputs of the universal filters are "constant  $Q$ ." For instance, a 2nd order bandpass filter operating in mode 1 with a 100kHz clock (see LTC1060 data sheet) ideally has a 1kHz or 2kHz center frequency, and a  $-3\text{dB}$  bandwidth equal to  $(f_0/Q)$ . When the clock frequency varies, the center frequency *and* bandwidth will vary at the same rate. In a constant bandwidth filter, when the center frequency varies, the  $Q$  varies accordingly to maintain a constant  $(f_0/Q)$  ratio. A constant bandwidth BP filter could be implemented using 2nd order switched capacitor filters but this is beyond the scope of this paper.

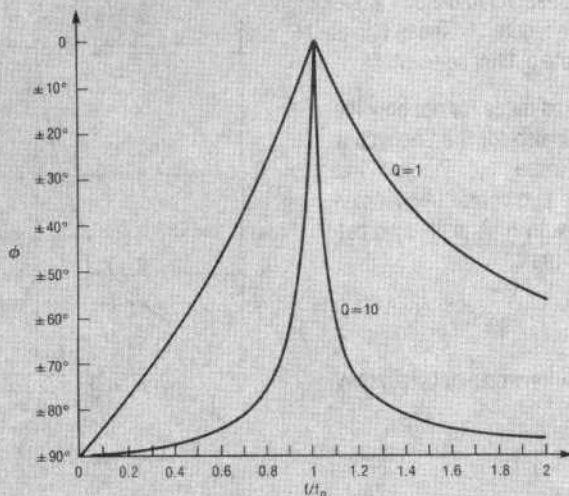

Figure 10. Phase Shift,  $\phi$ , of a 2nd Order BP Filter Section (LTC1059, 1/2 LTC1060, 1/3 LTC1061)

# Application Note 27A

## Using The Tables

Tables 1 through 4 were derived from textbook filter theory. They can be easily applied to the LTC filter family (LTC1059, 1060, 1061 and 1064) if the Q's are kept relatively low (<20) and the tuning resistors are at least 1% tolerance. These lower Q designs provide almost textbook BP filter performance using LTC's switched capacitor filters. For higher Q implementations, tuning should be avoided and the "A" versions of the LTC1059, 1060, 1061 or 1064 should be specified. Also, resistor tolerances of better than 1% are a necessity.

Table 1 may be used to find pole positions and Q's for Butterworth bandpass filters. It should be noted that the bandpass filters in these tables are geometrically symmetrical about their center frequencies,  $f_{oBP}$ . Any frequency,  $f_3$ , as shown in Figure 11 has its geometrical counterpart  $f_4$  such that:

$$f_4 = \frac{f_{oBP}^2}{f_3}$$

Additionally, Table 1 illustrates the attenuation at the frequencies  $f_3$ ,  $f_5$ ,  $f_7$  and  $f_9$  which correspond to bandwidths 2, 3, 4 and 5 times the passband (see Figure 11). These values allow the user to get a good estimate of filter selectivity.

An important approximation can be made for not only the Butterworth filters in Table 1, but also for the Chebyshev filter Tables 2, 3 and 4. Treating Figure 11 (or Figure 12) as a generalized bandpass filter, the two corner frequencies  $f_2$  and  $f_1$  can be seen to be nearly arithmetically symmetrical with respect to  $f_{oBP}$  provided that:

$$\frac{f_{oBP}}{BW} \gg \frac{1}{2}, BW = f_2 - f_1$$

Under this condition, for either Butterworth or Chebyshev bandpass filters:

$$f_{oBP} \cong \frac{f_3 - f_4}{2} + f_3$$

$$f_{oBP} \cong \frac{f_5 - f_6}{2} + f_5$$

- 
- 
- 

This is true for any bandwidth, BW, and any set of frequencies. The tables can now be arithmetically scaled as illustrated.

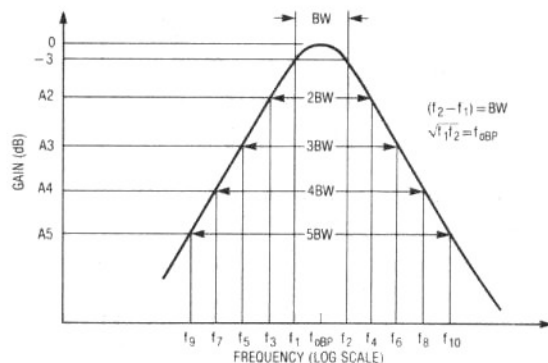

$$(f_1, f_2) = \frac{\pm BW + \sqrt{(BW)^2 + 4(f_{oBP})^2}}{2}$$

$$\text{MORE GENERALLY } (f_x, f_{x+1}) = \frac{\pm nBW + \sqrt{(nBW)^2 + 4(f_{oBP})^2}}{2}$$

(VALID FOR ANY  $f_x, f_{x+1}$  PAIR, ANY BW)

Figure 11. Generalized Bandpass Butterworth Response, (See Table 1)

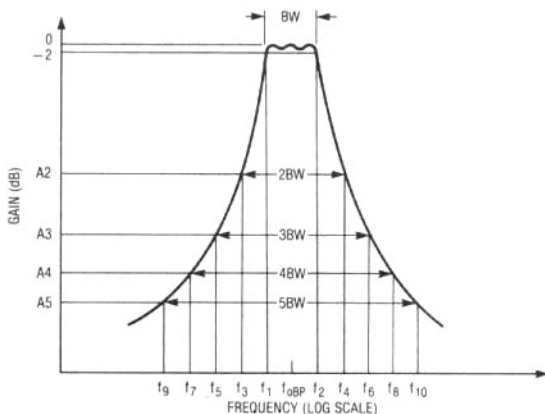

$$\sqrt{10} A_3 = f_{oBP}$$

$$(f_4, f_3) = \frac{\pm 2BW + \sqrt{(2BW)^2 + 4(f_{oBP})^2}}{2}$$

FOR ANY  $(f_x, f_{x+1})$  PAIR AND ANY CORRESPONDING BANDWIDTH (2BW, 3BW, ETC.)

FOR EXAMPLE:

$$(f_6, f_5) = \frac{\pm 3BW + \sqrt{(3BW)^2 + 4(f_{oBP})^2}}{2}$$

Figure 12. Generalized 4th, 6th, & 8th Order Chebyshev Bandpass Filter with 2dB Passband Ripple ( $A_{MAX}$ )



Table 1. Butterworth Bandpass Filters Normalized to  $f_{gap} = 1$

$f_{gap}$ (Hz)	$f_{gap}/BW$ (Hz)	$f_{o1}$ (Hz)	$f_{o2}$ (Hz)	$f_{o3}$ (Hz)	$f_{o4}$ (Hz)	$f_{-3dB}$ (Hz)	$f_{+3dB}$ (Hz)	$Q1 = Q2$	K	$f_1$ (Hz)	$f_3$ (Hz)	GAIN AT $f_3$ (dB)-A2	$f_5$ (Hz)	GAIN AT $f_5$ (dB)-A3	$f_7$ (Hz)	GAIN AT $f_7$ (dB)-A4	$f_9$ (Hz)	GAIN AT $f_9$ (dB)-A5	
4th Order Butterworth Bandpass Filter Normalized to its Center Frequency, $f_{gap} = 1$ , and -3dB Bandwidth (BW)																			
1		0.693	1.442			0.500	2.000	1.5		2.28	0.500	0.414	-12.3	0.303	-19.1	0.236	-24.0	0.193	-28.0
1	2	0.836	1.195			0.781	1.281	2.9		2.07	0.781	0.618	-12.3	0.500	-19.1	0.414	-24.0	0.351	-28.0
1	3	0.885	1.125			0.847	1.180	4.3		2.07	0.847	0.721	-12.3	0.618	-19.1	0.535	-24.0	0.469	-28.0
1	5	0.932	1.073			0.905	1.105	7.1		2.04	0.905	0.820	-12.3	0.744	-19.1	0.677	-24.0	0.618	-28.0
1	10	0.965	1.036			0.951	1.051	14.2		2.03	0.951	0.905	-12.3	0.861	-19.1	0.820	-24.0	0.781	-28.0
1	20	0.982	1.018			0.975	1.025	28.3		2.03	0.975	0.951	-12.3	0.928	-19.1	0.905	-24.0	0.883	-28.0
6th Order Butterworth Bandpass Filter Normalized to its Center Frequency, $f_{gap} = 1$ , and -3dB Bandwidth (BW)																			
Q3																			
1	1	0.650	1.539	1.000		0.500	2.000	2.2	1.0	4.79	0.500	0.414	-18.2	0.303	-28.6	0.236	-36.1	0.193	-41.9
1	2	0.805	1.242	1.000		0.781	1.281	4.1	2.0	4.18	0.781	0.618	-18.2	0.500	-28.6	0.414	-36.1	0.351	-41.9
1	3	0.866	1.155	1.000		0.847	1.180	6.1	3.0	4.07	0.847	0.721	-18.2	0.618	-28.6	0.535	-36.1	0.469	-41.9
1	5	0.917	1.091	1.000		0.905	1.105	10.0	5.0	4.03	0.905	0.820	-18.2	0.744	-28.6	0.677	-36.1	0.618	-41.9
1	10	0.958	1.044	1.000		0.951	1.051	20.0	10.0	4.01	0.951	0.905	-18.2	0.861	-28.6	0.820	-36.1	0.781	-41.9
1	20	0.979	1.022	1.000		0.975	1.025	40.0	20.0	4.00	0.975	0.951	-18.2	0.928	-28.6	0.905	-36.1	0.883	-41.9
8th Order Butterworth Bandpass Filter Normalized to its Center Frequency, $f_{gap} = 1$ , and -3dB Bandwidth (BW)																			
Q3 = Q4																			
1	1	0.809	1.237	0.636	1.574	0.500	2.000	1.1	2.9	10.14	0.500	0.414	-24.0	0.303	-38.0	0.236	-48.1	0.193	-55.8
1	2	0.907	1.103	0.795	1.259	0.781	1.281	2.2	5.4	8.48	0.781	0.618	-24.0	0.500	-38.0	0.414	-48.1	0.351	-55.8
1	3	0.938	1.066	0.858	1.166	0.847	1.180	3.3	7.9	8.15	0.847	0.721	-24.0	0.618	-38.0	0.535	-48.1	0.469	-55.8
1	5	0.962	1.039	0.912	1.097	0.905	1.105	5.4	13.1	8.05	0.905	0.820	-24.0	0.744	-38.0	0.677	-48.1	0.618	-55.8
1	10	0.981	1.019	0.955	1.047	0.951	1.051	10.8	26.2	8.00	0.951	0.905	-24.0	0.861	-38.0	0.820	-48.1	0.781	-55.8
1	20	0.990	1.010	0.977	1.023	0.975	1.025	21.6	52.3	8.00	0.975	0.951	-24.0	0.928	-38.0	0.905	-48.1	0.883	-55.8

Table 2. 4th Order Chebyshev Bandpass Filter Normalized to its Center Frequency  $f_{\text{OBF}} = 1$

$f_{\text{OBF}}$ (Hz)	$f_{\text{OBF}}/BW_1$ (Hz)	$f_{\text{O1}}$ (Hz)	$f_{\text{O2}}$ (Hz)	$f_{\text{OBF}}/BW_2$ (Hz)	$f_{-3\text{dB}}$ (Hz)	Q1 = Q2	K	$f_1$ (Hz)	$f_3$ (Hz)	GAIN AT $f_3$ (dB)-A2	$f_5$ (Hz)	GAIN AT $f_5$ (dB)-A3	$f_7$ (Hz)	GAIN AT $f_7$ (dB)-A4	$f_9$ (Hz)	GAIN AT $f_9$ (dB)-A5
<b>Passband Ripple, <math>A_{\text{MAX}} = 0.1\text{dB}</math></b>																
1	1	0.488	2.050	0.52	0.423	2.364	1.1	3.81	0.500	0.414	0.303	-08.7	0.236	-13.6	0.193	-17.4
1	2	0.703	1.422	1.03	0.626	1.597	1.8	2.86	0.781	0.618	0.500	-08.7	0.414	-13.6	0.351	-17.4
1	3	0.793	1.261	1.54	0.727	1.375	2.6	2.48	0.847	0.721	0.618	-08.7	0.535	-13.6	0.469	-17.4
1	5	0.871	1.148	2.58	0.825	1.213	4.3	2.38	0.905	0.820	0.744	-08.7	0.677	-13.6	0.618	-17.4
1	10	0.933	1.071	5.15	0.908	1.102	8.5	2.38	0.951	0.905	0.861	-08.7	0.820	-13.6	0.781	-17.4
1	20	0.966	1.035	10.31	0.953	1.050	16.9	2.37	0.975	0.951	0.928	-08.7	0.905	-13.6	0.883	-17.4
<b>Passband Ripple, <math>A_{\text{MAX}} = 0.5\text{dB}</math></b>																
1	1	0.602	1.660	0.72	0.523	1.912	1.6	3.80	0.500	0.414	0.303	-15.0	0.236	-20.2	0.193	-24.1
1	2	0.777	1.287	1.44	0.711	1.406	2.9	3.17	0.781	0.618	0.500	-15.0	0.414	-20.2	0.351	-24.1
1	3	0.845	1.182	2.16	0.795	1.258	4.3	3.07	0.847	0.721	0.618	-15.0	0.535	-20.2	0.469	-24.1
1	5	0.904	1.106	3.60	0.871	1.149	7.1	3.03	0.905	0.820	0.744	-15.0	0.677	-20.2	0.618	-24.1
1	10	0.951	1.051	7.19	0.933	1.072	14.1	2.98	0.951	0.905	0.861	-15.0	0.820	-20.2	0.781	-24.1
1	20	0.975	1.025	14.49	0.966	1.035	26.1	2.97	0.975	0.951	0.928	-15.0	0.905	-20.2	0.883	-24.1
<b>Passband Ripple, <math>A_{\text{MAX}} = 1.0\text{dB}</math></b>																
1	1	0.639	1.564	0.82	0.562	1.779	2.0	4.42	0.500	0.414	0.303	-17.7	0.236	-23.0	0.193	-27.0
1	2	0.799	1.251	1.64	0.741	1.349	3.7	3.85	0.781	0.618	0.500	-17.7	0.414	-23.0	0.351	-27.0
1	3	0.861	1.161	2.47	0.818	1.223	5.5	3.76	0.847	0.721	0.618	-17.7	0.535	-23.0	0.469	-27.0
1	5	0.914	1.094	4.12	0.886	1.129	9.2	3.71	0.905	0.820	0.744	-17.7	0.677	-23.0	0.618	-27.0
1	10	0.956	1.046	8.20	0.941	1.063	18.2	3.70	0.951	0.905	0.861	-17.7	0.820	-23.0	0.781	-27.0
1	20	0.978	1.022	16.39	0.970	1.031	36.5	3.63	0.975	0.951	0.928	-17.7	0.905	-23.0	0.883	-27.0
<b>Passband Ripple, <math>A_{\text{MAX}} = 2.0\text{dB}</math></b>																
1	1	0.668	1.496	0.93	0.588	1.672	2.7	6.00	0.500	0.414	0.303	-20.3	0.236	-25.5	0.193	-29.5
1	2	0.816	1.225	1.86	0.767	1.304	5.1	5.30	0.781	0.618	0.500	-20.3	0.414	-25.5	0.351	-29.5
1	3	0.873	1.145	2.79	0.837	1.195	7.5	5.22	0.847	0.721	0.618	-20.3	0.535	-25.5	0.469	-29.5
1	5	0.922	1.085	4.65	0.898	1.113	12.5	5.13	0.905	0.820	0.744	-20.3	0.677	-25.5	0.618	-29.5
1	10	0.960	1.041	9.35	0.946	1.055	24.9	5.13	0.951	0.905	0.861	-20.3	0.820	-25.5	0.781	-29.5
1	20	0.980	1.021	18.87	0.974	1.027	49.8	5.07	0.975	0.951	0.928	-20.3	0.905	-25.5	0.883	-29.5

\*\* $f_{\text{OBF}}/BW_1$  - This is the ratio of the bandpass filter center frequency to the ripple bandwidth of the filter.

\*\*\* $f_{\text{OBF}}/BW_2$  - This is the ratio of the bandpass filter center frequency to the -3dB filter bandwidth.

Table 3. 6th Order Chebyshev Bandpass Filter Normalized to its Center Frequency  $f_{0cp} = 1$

$f_{0cp}$ (Hz)	$f_{0cp}/BW_1$ (Hz)	$f_{01}$ (Hz)	$f_{02}$ (Hz)	$f_{03}$ (Hz)	$f_{0cp}/BW_2$ (Hz)	$f_{-3dB}$ (Hz)	$f_{+3dB}$ (Hz)	Q = 3	K	$f_1$ (Hz)	$f_3$ (Hz)	GAIN AT $f_3$ (dB)-A2	$f_5$ (Hz)	GAIN AT $f_5$ (dB)-A3	$f_7$ (Hz)	GAIN AT $f_7$ (dB)-A4	$f_9$ (Hz)	GAIN AT $f_9$ (dB)-A5	
<b>Passband Ripple, <math>A_{MAX} = 0.1dB</math></b>																			
1	1	0.558	1.791	1.000	0.72	0.523	1.912	2.4	1.0	9.9	0.500	0.414	0.303	-23.6	0.236	-31.4	0.193	-37.3	
1	2	0.741	1.349	1.000	1.44	0.711	1.406	4.3	2.1	7.9	0.781	0.618	0.500	-23.6	0.414	-31.4	0.351	-37.3	
1	3	0.818	1.222	1.000	2.16	0.795	1.258	6.3	3.1	7.5	0.847	0.721	0.618	-23.6	0.535	-31.4	0.469	-37.3	
1	5	0.886	1.128	1.000	3.60	0.871	1.149	10.4	5.2	7.4	0.905	0.820	0.744	-23.6	0.677	-31.4	0.618	-37.3	
1	10	0.941	1.062	1.000	7.19	0.933	1.072	20.6	10.3	7.3	0.951	0.905	0.861	-23.6	0.820	-31.4	0.781	-37.3	
1	20	0.970	1.030	1.000	14.49	0.966	1.035	41.3	20.6	7.3	0.975	0.951	0.928	-23.6	0.905	-31.4	0.883	-37.3	
<b>Passband Ripple, <math>A_{MAX} = 0.5dB</math></b>																			
1	1	0.609	1.641	1.000	0.86	0.574	1.741	3.6	1.6	14.8	0.500	0.414	0.303	-30.8	0.236	-36.6	0.193	-44.5	
1	2	0.776	1.288	1.000	1.72	0.750	1.333	6.6	3.2	12.5	0.781	0.618	0.500	-30.8	0.414	-36.6	0.351	-44.5	
1	3	0.844	1.185	1.000	2.57	0.824	1.213	9.7	4.8	12.0	0.847	0.721	0.618	-30.8	0.535	-36.6	0.469	-44.5	
1	5	0.903	1.107	1.000	4.29	0.880	1.123	16.1	8.0	11.8	0.905	0.820	0.744	-30.8	0.677	-36.6	0.618	-44.5	
1	10	0.950	1.052	1.000	8.55	0.943	1.060	32.0	16.0	11.8	0.951	0.905	0.861	-30.8	0.820	-36.6	0.781	-44.5	
1	20	0.975	1.026	1.000	16.95	0.971	1.030	63.8	32.0	11.4	0.975	0.951	0.928	-30.8	0.905	-36.6	0.883	-44.5	
<b>Passband Ripple, <math>A_{MAX} = 1.0dB</math></b>																			
1	1	0.626	1.598	1.000	0.91	0.583	1.687	4.5	2.0	20.1	0.500	0.414	0.303	-34.0	0.236	-41.9	0.193	-47.8	
1	2	0.787	1.271	1.000	1.83	0.763	1.310	8.3	4.1	17.1	0.781	0.618	0.500	-34.0	0.414	-41.9	0.351	-47.8	
1	3	0.852	1.174	1.000	2.74	0.834	1.199	12.3	6.1	16.7	0.847	0.721	0.618	-34.0	0.535	-41.9	0.469	-47.8	
1	5	0.908	1.101	1.000	4.59	0.887	1.115	20.3	10.1	16.4	0.905	0.820	0.744	-34.0	0.677	-41.9	0.618	-47.8	
1	10	0.953	1.050	1.000	9.17	0.947	1.056	40.5	20.2	16.4	0.951	0.905	0.861	-34.0	0.820	-41.9	0.781	-47.8	
1	20	0.976	1.024	1.000	18.18	0.973	1.028	81.0	40.5	16.4	0.975	0.951	0.928	-34.0	0.905	-41.9	0.883	-47.8	
<b>Passband Ripple, <math>A_{MAX} = 2.0dB</math></b>																			
1	1	0.639	1.565	1.000	0.97	0.609	1.642	6.0	2.7	31.7	0.500	0.414	0.303	-37.5	0.236	-45.4	0.193	-51.3	
1	2	0.795	1.257	1.000	1.94	0.775	1.291	11.1	5.4	27.4	0.781	0.618	0.500	-37.5	0.414	-45.4	0.351	-51.3	
1	3	0.858	1.165	1.000	2.91	0.843	1.187	16.5	8.1	26.7	0.847	0.721	0.618	-37.5	0.535	-45.4	0.469	-51.3	
1	5	0.912	1.096	1.000	4.83	0.902	1.109	27.2	13.6	26.2	0.905	0.820	0.744	-37.5	0.677	-45.4	0.618	-51.3	
1	10	0.955	1.047	1.000	9.71	0.950	1.053	54.3	27.1	26.0	0.951	0.905	0.861	-37.5	0.820	-45.4	0.781	-51.3	
1	20	0.977	1.023	1.000	19.61	0.975	1.026	108.5	54.2	26.0	0.975	0.951	0.928	-37.5	0.905	-45.4	0.883	-51.3	

\* $f_{0cp}/BW_1$  - This is the ratio of the bandpass filter center frequency to the ripple bandwidth of the filter.

\*\* $f_{0cp}/BW_2$  - This is the ratio of the bandpass filter center frequency to the -3dB filter bandwidth.

Table 4. 8th Order Chebyshev Bandpass Filter Normalized to its Center Frequency  $f_{0BP} = 1$

$f_{0BP}$ (Hz)	$f_{0BP}/BW_1$ (Hz)	$f_{01}$ (Hz)	$f_{02}$ (Hz)	$f_{03}$ (Hz)	$f_{04}$ (Hz)	$f_{0BP}/BW_2$ (Hz)	$f_{-3dB}$ (Hz)	$Q1 = Q2$	$Q3 = Q4$	$K$	$f_1$ (Hz)	$f_2$ (Hz)	$f_3$ (Hz)	$f_4$ (Hz)	$f_5$ (Hz)	$f_6$ (Hz)	$f_7$ (Hz)	$f_8$ (Hz)	$f_9$ (Hz)	$f_{10}$ (Hz)	GAIN AT $f_1$ (dB)-A4	GAIN AT $f_2$ (dB)-A3	GAIN AT $f_3$ (dB)-A2	GAIN AT $f_4$ (dB)-A1	GAIN AT $f_5$ (dB)-A5	
<b>Passband Ripple, <math>A_{MAX} = 0.1dB</math></b>																										
1	1	0.765	1.274	0.584	1.713	0.82	1.776	1.6	4.4	40.6	0.500	0.414	-23.4	0.303	-38.8	0.296	-49.3	0.193	-57.1							
1	2	0.989	1.125	0.757	1.330	1.65	0.742	1.948	3.2	7.9	32.1	0.781	-23.4	0.500	-38.8	0.414	-49.3	0.351	-57.1							
1	3	0.925	1.081	0.830	1.204	2.48	0.818	1.222	4.7	11.6	30.5	0.847	-23.4	0.618	-38.8	0.535	-49.3	0.469	-57.1							
1	5	0.954	1.048	0.884	1.118	4.12	0.886	1.129	7.9	19.1	29.9	0.905	-23.4	0.744	-38.8	0.677	-49.3	0.618	-57.1							
1	10	0.977	1.023	0.945	1.068	8.20	0.941	1.063	15.7	37.9	29.8	0.951	-23.4	0.861	-38.8	0.820	-49.3	0.781	-57.1							
1	20	0.988	1.012	0.972	1.028	16.39	0.970	1.031	31.4	75.7	29.8	0.975	-23.4	0.928	-38.8	0.905	-49.3	0.883	-57.1							
<b>Passband Ripple, <math>A_{MAX} = 0.5dB</math></b>																										
1	1	0.808	1.238	0.613	1.632	0.91	0.593	1.686	2.4	6.4	90.1	0.500	0.414	-30.2	0.303	-45.5	0.296	-56.0	0.193	-63.9						
1	2	0.900	1.111	0.777	1.286	1.83	0.763	1.310	4.8	11.8	74.3	0.781	-30.2	0.500	-45.5	0.414	-56.0	0.351	-63.9							
1	3	0.932	1.073	0.845	1.183	2.74	0.834	1.199	7.1	17.4	71.5	0.847	-30.2	0.618	-45.5	0.535	-56.0	0.469	-63.9							
1	5	0.959	1.043	0.903	1.107	4.59	0.897	1.115	11.8	28.7	70.0	0.905	-30.2	0.744	-45.5	0.677	-56.0	0.618	-63.9							
1	10	0.979	1.021	0.960	1.062	9.17	0.947	1.056	23.6	57.1	70.0	0.951	-30.2	0.861	-45.5	0.820	-56.0	0.781	-63.9							
1	20	0.988	1.010	0.975	1.026	18.18	0.973	1.028	47.2	114.0	70.0	0.975	-30.2	0.928	-45.5	0.905	-56.0	0.883	-63.9							
<b>Passband Ripple, <math>A_{MAX} = 1.0dB</math></b>																										
1	1	0.814	1.228	0.622	1.607	0.95	0.604	1.656	3.0	8.0	162.8	0.500	0.414	-32.9	0.303	-48.3	0.296	-58.8	0.193	-66.6						
1	2	0.903	1.107	0.784	1.275	1.90	0.771	1.297	6.0	14.8	133.2	0.781	-32.9	0.500	-48.3	0.414	-58.8	0.351	-66.6							
1	3	0.934	1.070	0.850	1.177	2.85	0.840	1.191	8.9	21.8	126.1	0.847	-32.9	0.618	-48.3	0.535	-58.8	0.469	-66.6							
1	5	0.960	1.041	0.906	1.103	4.74	0.900	1.111	14.9	36.0	127.7	0.905	-32.9	0.744	-48.3	0.677	-58.8	0.618	-66.6							
1	10	0.980	1.020	0.962	1.050	9.52	0.949	1.054	29.7	71.7	124.0	0.951	-32.9	0.861	-48.3	0.820	-58.8	0.781	-66.6							
1	20	0.990	1.010	0.976	1.025	18.87	0.974	1.027	59.4	143.0	120.0	0.975	-32.9	0.928	-48.3	0.905	-58.8	0.883	-66.6							
<b>Passband Ripple, <math>A_{MAX} = 2.0dB</math></b>																										
1	1	0.820	1.220	0.629	1.589	0.98	0.613	1.631	4.0	10.6	374.8	0.500	0.414	-35.4	0.303	-50.8	0.296	-61.3	0.193	-69.2						
1	2	0.905	1.104	0.789	1.268	1.96	0.777	1.287	7.9	19.6	312.6	0.781	-35.4	0.500	-50.8	0.414	-61.3	0.351	-69.2							
1	3	0.936	1.088	0.853	1.172	2.95	0.845	1.184	11.9	29.0	302.0	0.847	-35.4	0.618	-50.8	0.535	-61.3	0.469	-69.2							
1	5	0.961	1.040	0.909	1.100	4.90	0.903	1.107	19.7	47.9	302.0	0.905	-35.4	0.744	-50.8	0.677	-61.3	0.618	-69.2							
1	10	0.980	1.020	0.953	1.049	9.80	0.950	1.052	39.5	95.4	302.0	0.951	-35.4	0.861	-50.8	0.820	-61.3	0.781	-69.2							
1	20	0.990	1.010	0.976	1.024	19.61	0.975	1.026	79.0	190.0	302.0	0.975	-35.4	0.928	-50.8	0.905	-61.3	0.883	-69.2							

\*\* $f_{0BP}/BW_1$  - This is the ratio of the bandpass filter center frequency to the ripple bandwidth of the filter.

\*\*\* $f_{0BP}/BW_2$  - This is the ratio of the bandpass filter center frequency to the -3dB filter bandwidth.

## Chebyshev or Butterworth — A System Designers Confusion

The filter designer/mathematician is familiar with terms such as:

$$K_C = \tanh A$$

$$A = \frac{1}{n} \cosh^{-1} \frac{1}{\epsilon}$$

Ripple bandwidth =  $1/\cosh A$   
and  $A_{dB} = 10 \log [1 + \epsilon^2 C_n^2(\Omega)]$ .

This is all gobbledegook (not to be confused with floobydust) to the system designer. The system designer is accustomed to  $-3dB$  bandwidths and may be tempted to use only Butterworth filters because they have the cherished  $-3dB$  bandwidths. But specs. are specs. and Butterworth bandpass filters are only so good. Chebyshev bandpass filters trade off ripple in the passband for somewhat steeper rolloff to the stopband. More ripple translates to a higher "Q" filter. The pain of the filter designer is sometimes tolerable to the system designer.

Tables 1 through 4 are unique (we think) in that they present  $-3dB$  bandwidths for Chebyshev filters for use by system designers. Nevertheless we would be amiss to Mr. Chebyshev if we did not, at least, explain ripple bandwidth.

Figure 13 shows the Chebyshev bandpass filter at frequencies near the passband.

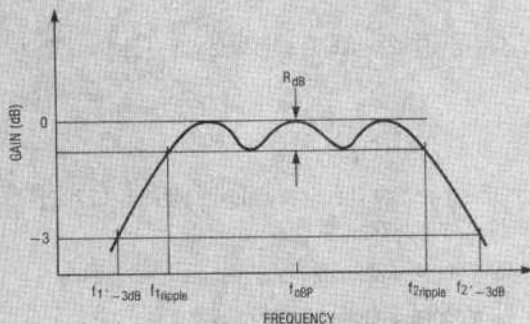

Figure 13. Typical Chebyshev BP Filter — Close-up of Passband

It can be clearly seen that the ripple bandwidth ( $f_{1ripple} - f_{2ripple}$ ) is the band of passband frequencies where the ripple is less than or equal to a specific value ( $R_{dB}$ ). The  $-3dB$  bandwidth is seen to be greater than the ripple bandwidth and that is the subject of much confusion on the part of the system designer.

Tables 1 through 4 allow the system designer to use  $-3dB$  bandwidths to specify Chebyshev BP filters. The Chebyshev approximation to the ideal BP filter has many benefits over the Butterworth filter near the cutoff frequency.

**YOU CAN DESIGN WITH CHEBYSHEV FILTERS!!!**

### EXAMPLE 3 — DESIGN

Use Table 4 to design an 8th order all pole Chebyshev bandpass filter centered at  $f_{0BP} = 10.2kHz$  with a  $-3dB$  bandwidth equal to 800Hz as shown in Figure 14.

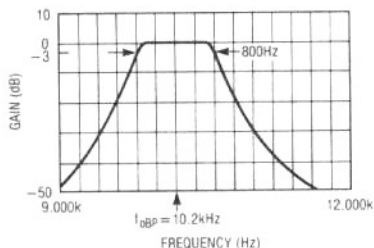

Figure 14. Example 3 — 8th Order Chebyshev BP Filter  
 $f_{0BP} = 10.2kHz$ ,  $BW = 800Hz$

We choose  $A_{MAX} = 0.1dB$ . Now we calculate:

$$\frac{f_{0BP}}{f_{BW(-3dB)}} = \frac{10.2kHz}{800Hz} = 12.75$$

We can now extract from Table 4 the following line:

$f_{0BP}$	$f_{0BP}/BW_1$	$f_{01}(Hz)$	$f_{02}(Hz)$	$f_{03}(Hz)$	$f_{04}(Hz)$	$f_{0BP}/BW_2$	$Q_1 = Q_2$	$Q_3 = Q_4$	K
1	10	0.977	1.023	0.945	1.058	8.20	15.7	37.9	29.8

Since our bandwidth ratio  $f_{0BP}/BW_2$  is not exactly on a chart line, but between two lines, we must arithmetically scale to obtain our design parameters. Our  $f_{0BP}/BW_2$  ratio lies between 8.2 and 16.39. (Remember, this is  $-3dB$  BW!)

## Application Note 27A

For a symmetrical bandpass filter the poles are symmetrical about  $f_{oBP}$ . Then:

$$(f_{o2} - f_{o1}) = (1.023 - 0.977) \times 10.2\text{kHz} \times \left(\frac{8.2}{12.75}\right) = 302\text{Hz}$$

$$\text{Note: } \left(\frac{8.2}{12.75}\right) = \frac{f_{oBP}}{BW} \text{ Scaling Factor}$$

So our first two poles lie symmetrically about  $f_o(10.2\text{kHz})$  and are 302Hz apart:

$$f_{o2} = 10200\text{Hz} + 302\text{Hz}/2 = 10351\text{Hz}$$

$$f_{o1} = 10200\text{Hz} - 302\text{Hz}/2 = 10049\text{Hz}$$

The Q of these two poles is equal and is also scaled:

$$Q_1 = Q_2 = 15.7 \times \frac{12.75}{8.2} = 24.4$$

We next calculate the two additional poles:

$$(f_{o4} - f_{o3}) = (1.058 - 0.945) \times 10.2\text{kHz} \times \frac{8.2}{12.75} = 741\text{Hz}$$

$$f_{o3} = 10200\text{Hz} - 741\text{Hz}/2 = 9830\text{Hz}$$

$$f_{o4} = 10200\text{Hz} + 741\text{Hz}/2 = 10571\text{Hz}$$

The Q's are:

$$Q_3 = Q_4 = 37.9 \times \frac{12.75}{8.2} = 58.9$$

Q's of this magnitude are difficult to realize no matter how the filter is realized. The filter designer should strive for Q's no greater than 20 and perhaps no greater than 10 at frequencies above 20kHz. K, for this example, is not scaled and will be equal to 29.8 from Table 4.

### Example 3 — Frequency Response Estimation

Table 4 (and also Tables 1, 2 and 3) may be used by the filter designer to obtain a good approximation to the overall shape of the bandpass filter. Referring to Figure 12 for Chebyshev filters, we may use the charts to find  $f_3, f_5, f_7, \dots$ . These frequencies define the band edges at 2, 3, 4,.....times the ripple bandwidth of the Chebyshev Filter.

Example 3 specified a 10.2kHz bandpass filter with an 800Hz -3dB bandwidth. Our task, if we choose to accept

it, is to convert our -3dB bandwidth to the ripple bandwidth of the filter so that we may use the tables.

Recalling that:

$$\frac{f_{oBP}}{BW_{2(-3dB)}} = 12.75 \quad \text{and that } f_{oBP} = 1,$$

(Because all the tables are normalized), we calculate  $BW_{2(-3dB)} = .0784$

Comparing the Table 4 values for  $A_{MAX} = 0.1\text{dB}$  we note that:

$$\frac{f_{oBP}}{BW_{1(\text{ripple})}} \cong \frac{f_{oBP}}{BW_{2(-3dB)}} \times (\text{Scaling Factor})$$

For  $A_{MAX} = 0.1\text{dB}$ , 8th order Chebyshev, this factor is approximately 0.82. For other order filters and/or different values of  $A_{MAX}$  we can examine the corresponding chart values to find our scaling factor.

So our ripple BW is:

$$BW_{2(-3dB)} \times (\text{Scaling Factor}) = BW_{1(\text{ripple})}$$
$$.0784 \times 0.82 = .0643$$

Now we can calculate  $f_3, f_5, f_7, \dots$ . Notice that once we find  $f_3, f_5, f_7, \dots$  it does not matter where on the table our filter falls. The filter bandwidth determines  $f_3, f_5, f_7, \dots$  and once we know these frequencies we can directly get our gains at these frequencies.

By formula:

$$(f_x, f_{x+1}) = \frac{\pm nBW + \sqrt{(nBW)^2 + 4(f_{oBP})^2}}{2}$$

for our case  $f_{oBP} = 1$

Calculating:

$$2BW = .1286 \quad \frac{\pm 2BW + \sqrt{(.1286)^2 + 4}}{2} = 1.0664, 0.9378$$

$$3BW = .1929 \quad \frac{\pm 3BW + \sqrt{(.1929)^2 + 4}}{2} = 1.1011, 0.9082$$

Then we can denormalize to find points for our Bode plot:

$$(f_3, f_4) = 0.9378 \times f_{0BP} = 0.9378 \times 10.2\text{kHz} = 9.566\text{kHz}$$

$$1.0664 \times f_{0BP} = 1.0664 \times 10.2\text{kHz} = 10.877\text{kHz}$$

Gain = -23.4dB both  $f_3$  and  $f_4$

$$(f_5, f_6) = 0.9082 \times f_{0BP} = 0.9082 \times 10.2\text{kHz} = 9.264\text{kHz}$$

$$1.1011 \times f_{0BP} = 1.1011 \times 10.2\text{kHz} = 11.231\text{kHz}$$

Gain = -38.8dB both  $f_5$  and  $f_6$

## Example 3 — Implementation

The 10.2kHz ( $f_{0BP}$ ), 8th order bandpass filter can be implemented with an LTC1064A using three sections in mode 2 and one section in mode 3. The implementation is shown briefly in Figures 15 and 16. The calculations are not shown here, but are similar to the previous hardware implementations of example 1 and 2.

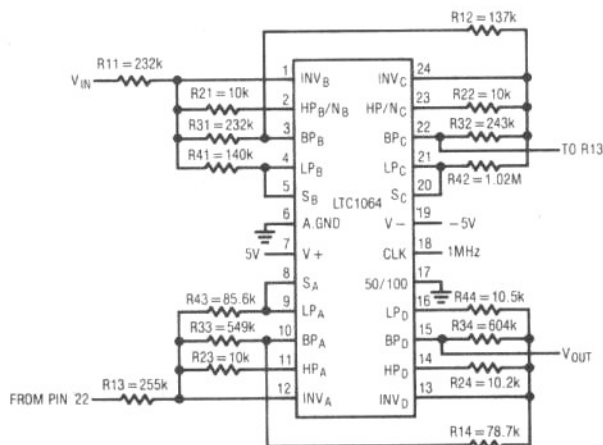

Figure 15. LTC1064 Implementation Pinout — 10.2kHz 8th Order BPF

# Application Note 27A

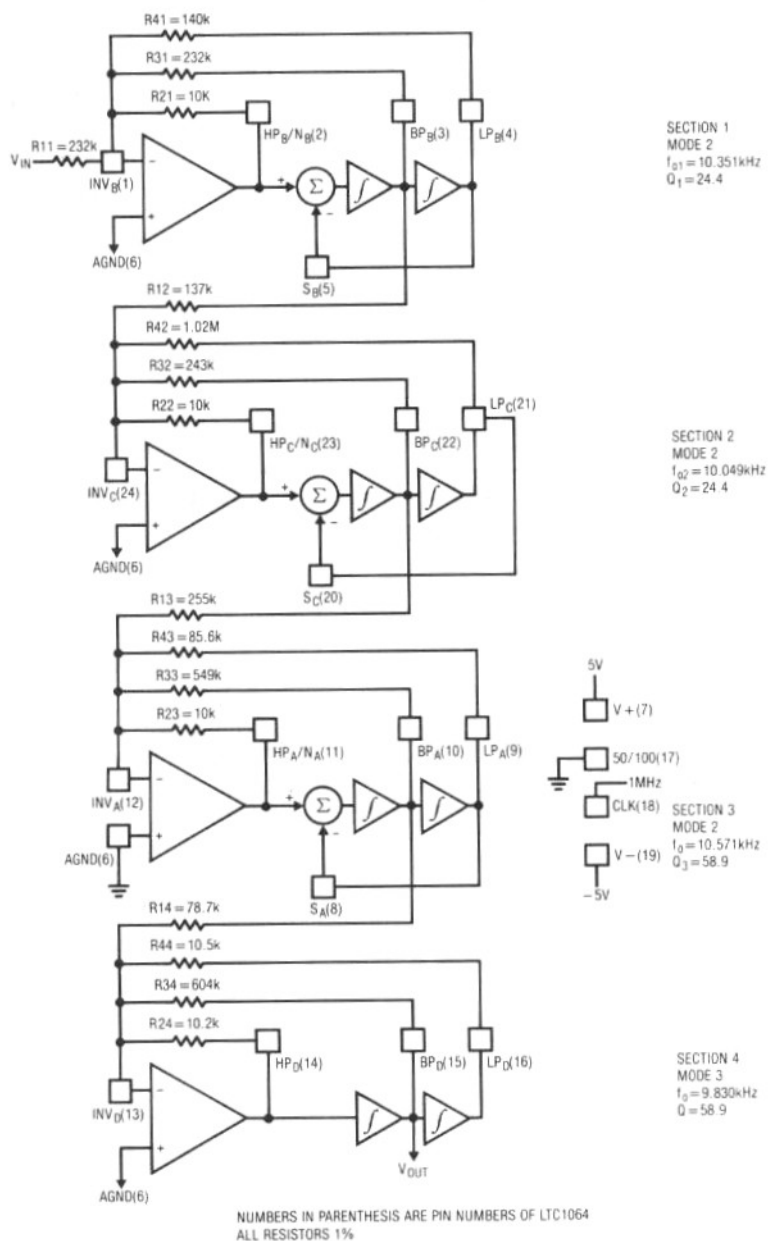

Figure 16. Implementation of 10.2kHz 8th Order BPF — Section by Section For LTC1054