



For Service Manuals Contact
MAURITRON TECHNICAL SERVICES
 8 Cherry Tree Rd, Chinnor
 Oxon OX9 4QY
 Tel:- 01844-351694 Fax:- 01844-352554
 Email:- enquiries@mauritron.co.uk

Contents

703

Chapter 1 GENERAL INFORMATION

1.1	Introduction	5
1.2	Data summary	6
1.3	Accessories	10

Chapter 2 OPERATION

2.1	Preparation for use	13
2.2	Controls - supply, tuning and output	14
2.3	Controls - modulation, fine tuning and calibrator	16
2.4	Setting frequency..	17
2.5	Frequency modulation	19
2.6	Amplitude modulation	20
2.7	Setting output	21
2.8	Mismatched loads.	21
2.9	A. F. output	23
	Decibel conversion table	24

Chapter 3 TECHNICAL DESCRIPTION

3.1	Circuit summary..	27
3.2	Oscillators	28
3.3	Automatic level control and amplitude modulation.	29
3.4	Modulation oscillator and drive circuits	30
3.5	Frequency modulation and frequency shift...	30
3.6	Crystal calibrator.	31
3.7	Power supply	33
3.8	Attenuators	33
3.9	Mechanical description...	33

Chapter 4 MAINTENANCE

4.1	Introduction	37
4.2	Removal of case	37
4.3	Overall performance tests	37
4.3.1	Test apparatus.	37
4.3.2	Frequency	37
4.3.3	R. F. output	38
4.3.4	Frequency modulation.	39
4.3.5	Modulation oscillator..	40
4.3.6	Amplitude modulation..	40
4.3.7	External modulation...	40
4.3.8	A. M. on c. w.	40
4.4	Cleaning and lubrication..	40
4.5	Maintenance accessories	41

Chapter 5 REPAIR

5.1	Introduction	42
5.2	Fault finding	42
5.3	Circuit voltages...	44
5.4	Waveforms	44
5.5	Access to components	45
5.6	Component location	47
5.7	Fuses	50
5.8	Adjustment and calibration	50
5.8.1	Test apparatus	50
5.8.2	Power supply - board ①	50
5.8.3	Modulation oscillator - boards ④, ⑤, ⑧	51
5.8.4	F. M. and ΔF drive - board ②	51
5.8.5	Modulation monitor - board ⑦	52
5.8.6	Reactor linearizer - board ③	52
5.8.7	Automatic level control and amplitude modulator - board ⑥	53
5.8.8	Crystal calibrator - boards ⑦, ③③, ③④	53
5.8.9	R. F. oscillators	54

INDEX TO UNITS	56
----------------	-----	-----	-----	-----	----

Chapter 6 REPLACEABLE PARTS

Introduction and ordering	59
Parts lists - (see Index on page 56)	

Chapter 7 CIRCUIT DIAGRAMS

Fig.					
7.1	4 to 10 MHz oscillator	81
7.2	10 to 90 MHz oscillator...	83
7.3	88 to 220 MHz oscillator..	85
7.4	215 to 500 MHz oscillator.	87
7.5	440 to 1000 MHz oscillator	89
7.6	A. L. C. and amplitude modulator.	91
7.7	38SC	93
7.8	Modulation oscillator	93
7.9	38SB & 38SA	95
7.10	F. M. and frequency shift	95
7.11	Crystal calibrator.	97
7.12	38SD & 38SE	99
7.13	Crystal calibrator filters	99
7.14	Power supply	101
7.15	Attenuators	103
7.16	Interconnections - top mother board	105
7.17	40SA	107
7.18	Interconnections - bottom mother board	107

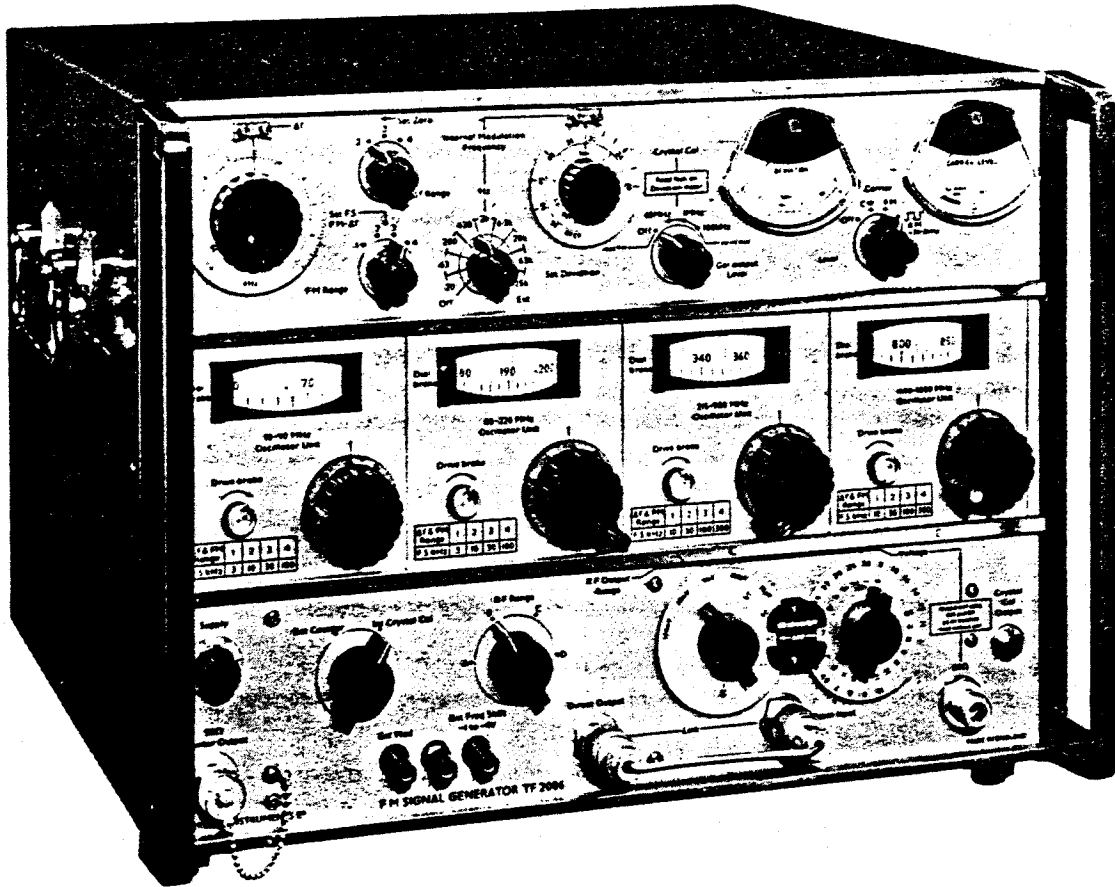

Fig. 1.1 TF 2006 F.M. Signal Generator

For Service Manuals Contact
MAURITRON TECHNICAL SERVICES
8 Cherry Tree Rd, Chinnor
Oxon OX9 4QY
Tel:- 01844-351694 Fax:- 01844-352554
Email:- enquiries@mauritron.co.uk

1.1 INTRODUCTION

TF 2006 is a signal generator providing c. w., f. m. and square wave a. m. outputs over a range of frequencies extending well beyond the limits of the v. h. f. band. The design provides entirely separate oscillator units for each frequency range. Five units are available giving a total frequency coverage of 4 to 1000 MHz; instruments can be supplied with up to four of these fitted.

Use of independent oscillators together with the patented method of range switching means that full rated frequency stability is maintained after range changing or after temporary interruption of the carrier.

Frequency modulation is provided on all ranges and the same system gives high discrimination calibrated electrical fine tuning. Both of these facilities can be standardized against the crystal calibrator. Frequency drift and microphonic modulation are both low, allowing the fine tuning to be used to set the instrument accurately to an absolute frequency or to make measurements about narrow band widths. The resistance to microphony is such that less than 12 kHz deviation is produced at vibration levels greater than those encountered on board a major warship.

An internal continuously tuned oscillator provides modulating frequencies for f. m. between 20 Hz and 125 kHz and the same bandwidth is available with external modulating signals. An alternative input, intended for external frequency shift, extends the bandwidth down to d. c. The maximum deviation is 100 kHz at carrier frequencies below 215 MHz and 300 kHz at higher carrier frequencies

for all modulating signals. The modulation characteristic permits use with multiplex signals such as telemetry or f. m. stereo broadcast.

Only simple amplitude modulation facilities are provided but these allow the generator to be used as an r. f. bridge source or for other r. f. measurements.

Crystal check points are available at intervals of 10 MHz, 1 MHz and 100 kHz. The null points are shown on a meter and are processed to ensure freedom from spurious markers and thereby give an unambiguous indication. Alternatively, headphones may be used.

An effective automatic level control system maintains the reading of the carrier level meter constant irrespective of changes of carrier frequency over the entire r. f. range. A maximum source e. m. f. of 200 mV can be obtained at all frequencies. Output is controlled by cam operated 20 dB and 1 dB step attenuators with voltage and dB calibration in terms of p. d. across a 50 Ω load or of source e. m. f.; interpolation between attenuator steps is provided by the carrier level control and meter. Thorough screening of all r. f. circuits enables the lower outputs to be used with confidence.

Advanced constructional techniques have been used; specially designed tuning capacitors ensure a new order of mechanical stability. Printed circuit methods are fully exploited; critical components are formed in this way and the use of printed wiring boards and tapes, in place of cable forms, control the effect of stray impedances and couplings.

1.2 DATA SUMMARY

Frequency

Range: 4 to 1000 MHz using 5 oscillator units, of which any 4 can be assembled into a generator.

- | | | |
|--------------------|---------------------|-------------------|
| (1) 4 to 10 MHz | (2) 10 to 90 MHz | (3) 88 to 220 MHz |
| (4) 215 to 500 MHz | (5) 440 to 1000 MHz | |

Mechanical tuning discrimination:

Each carrier range unit has an independent 28 turn knob. The main scale is substantially linear and a vernier scale has 100 divisions.

Calibration accuracy:

$\pm \frac{1}{2}$ of a scale division, but the internal crystal calibrator can be used to increase the accuracy to ± 3 parts in $10^6 + 1$ kHz.

<i>Frequency range</i>	<i>Frequency scale divisions</i>
4 to 10 MHz:	100 kHz
10 to 90 MHz:	2 MHz
88 to 220 MHz:	2 MHz
215 to 500 MHz:	5 MHz
440 to 1000 MHz:	10 MHz

Stability:

At a constant ambient temperature in the range 10 °C to 35 °C, immediately after switching on, the drift is typically 10 kHz per 15 minutes at 10 MHz and 50 kHz per 15 minutes at 1000 MHz.

At a constant ambient temperature in the range of 10 °C to 35 °C and after thermal equilibrium has been reached, the drift does not exceed 15 p. p. m. +1.5 kHz per 15 minutes.

Thermal equilibrium is reached after the following times:

For Service Manuals Contact
MAURITRON TECHNICAL SERVICES
8 Cherry Tree Rd, Chinnor
Oxon OX9 4QY
Tel:- 01844-351694 Fax:- 01844-352554
Email:- enquiries@mauritron.co.uk

<i>Frequency range (MHz)</i>	<i>Time (min)</i>
4 - 10	30
10 - 90	90
88 - 220	60
215 - 500	45
440 - 1000	45

The thermal equilibrium times stated are not additive. If, on a given frequency range thermal equilibrium has been reached, and the instrument is switched to another range, the drift specification will be met within 3 minutes.

One hour after a 10 °C change in ambient temperature, within the range 10 °C to 35 °C, the drift does not exceed 100 p. p. m. +3 kHz per 15 minutes; after 3 hours the drift rate does not exceed 15 p. p. m. +1.5 kHz per 15 minutes.

For a supply voltage change of $\pm 10\%$ about 230 V or 115 V, the frequency change is less than 500 Hz at the highest generated frequency.

- Load reaction:** With the coarse attenuator set to give at least 20 dB attenuation, the maximum frequency shift between the output open circuited and loaded with 50 Ω is 1 kHz.
- Attenuator reaction:** With the output loaded with 50 Ω , the maximum frequency shift between a coarse attenuator setting of 20 dB attenuation and any greater attenuation is 500 Hz.
- Electrical fine tuning:** Three calibrated ranges are provided for each carrier band.
- Carrier oscillator units 4 to 10, 10 to 90, and 88 to 220 MHz have fine tuning ranges of ± 10 , 30 and 100 kHz. The smallest scale division is 200 Hz.
- Carrier oscillator units 215 to 500 and 440 to 1000 MHz have fine tuning ranges of ± 30 , 100 and 300 kHz. The smallest scale division is 1 kHz.
- Accuracy:** When standardized independently for positive and negative excursion on the 100 and 300 kHz ranges, the accuracy is as follows:

ΔF range (kHz)	Accuracy (kHz)
300	± 6
100	± 2
30	± 1.5
10	± 1

- Internal crystal calibrator:** A meter null indication is provided at all 10, 1 and 0.1 MHz points.
- The meter readout gives 1 kHz discrimination at check points.
- Accuracy:** The oven controlled crystal reaches 3 parts in 10^6 after 15 minutes in the ambient temperature range of 10 $^{\circ}\text{C}$ to 35 $^{\circ}\text{C}$. To reduce external d. c. consumption the crystal oven can be switched off.

R.F. output

- Level:** 200 mV e. m. f. down to 0.2 μV .
- Attenuators:**
- | | |
|-----------|------------------------|
| Coarse: | 100 dB in 20 dB steps. |
| Fine: | 20 dB in 1 dB steps. |
| External: | 6 dB pad. |
- A. L. C. :** With a terminated output, automatic level control maintains the level meter reading substantially constant so that no manual adjustment is necessary.
- Total level accuracy:**
- | |
|------------------------|
| ± 1 dB to 500 MHz |
| ± 2 dB to 1000 MHz |
- Effective source/output impedance:**
- | |
|---|
| V. S. W. R. better than 1.15 to 200 MHz |
| 1.25 to 500 MHz |
| 1.5 to 1000 MHz |

R.F. output (continued)

Counter output: 100 mV r. m. s. minimum across 50 Ω up to 600 MHz.
50 mV r. m. s. minimum across 50 Ω up to 1000 MHz.

C. W. distortion:
(total harmonic) Less than 2½% from 90 MHz to 1000 MHz.
Less than 4% from 4 MHz to 90 MHz.

For Service Manuals Contact
MAURITRON TECHNICAL SERVICES
8 Cherry Tree Rd, Chinnor
Oxon OX9 4QY
Tel:- 01844-351694 Fax:- 01844-352554
Email:- enquiries@mauritron.co.uk

Leakage: With a two-turn loop of one inch diameter connected to a receiver, a signal cannot be detected at a distance greater than 1 in from the signal generator at frequencies up to 500 MHz with the receiver sensitivity set at 1 μ V, or above 500 MHz with the receiver sensitivity set at 2 μ V.

Frequency modulation

Monitor: A full wave peak reading meter is scaled 0 - 100 and 0 - 30.

Deviation range: Four ranges are provided for each carrier band. Carrier oscillator units 4 to 10, 10 to 90, and 88 to 220 MHz give monitor full scales of 3, 10, 30 and 100 kHz peak deviation. Carrier oscillator units 215 to 500, and 440 to 1000 MHz have deviation ranges of 10, 30, 100 and 300 kHz.

Modulation bandwidth: D. C. and 20 Hz to 125 kHz. Suitable for f. m. stereo. Typical channel separation figures are 33 dB at 50 Hz, 36 dB at 1 kHz, and 34 dB at 15 kHz.

Deviation accuracy: At 1 kHz modulation frequency the deviation accuracy, when standardized against the internal crystal calibrator is $\pm 6\%$ of f. s. d. on all ranges.

Without standardization the accuracy is $\pm 12\%$ on all ranges.

Fine tuning and frequency modulation can be used simultaneously, provided the total excursion does not exceed the range maximum shown for fine tuning, but the deviation accuracy will be impaired.

Modulation frequency characteristic:

± 0.5 dB relative to 1 kHz from 20 Hz to 125 kHz at carrier frequencies from 10 MHz to 1000 MHz.
 ± 0.5 dB relative to 1 kHz from 20 Hz to 20 kHz at carrier frequencies from 4 MHz to 10 MHz.

F. M. distortion: Using the internal oscillator for maximum deviation, at modulating frequencies from 100 Hz to 20 kHz, the total harmonic distortion does not exceed 2%, except between 4 MHz and 20 MHz, or above 500 MHz carrier frequency where there may be an extra 2%. At modulating frequencies from 20 kHz to 125 kHz at maximum deviation, the total intermodulation distortion (CCIF method) does not exceed 3%.

A. M. on f. m. At maximum deviation on the ranges from 90 MHz to 1000 MHz, less than 2½% a. m. At 75 kHz deviation on the ranges from 4 MHz to 90 MHz, less than 6% a. m.

F. M. noise: With psophometric weighting as follows:

Telephone: less than 20 Hz, typically 12 Hz.

Flat: less than 60 Hz, typically 40 Hz.

Internal modulation oscillator: Range: 20 Hz to 125 kHz.
 Dial accuracy: $\pm 10\%$.
 Output level: 0 dBm ± 0.5 dB into 600 Ω from 30 Hz to 125 kHz.
 Distortion: Less than 1% from 30 Hz to 125 kHz.

External modulation: Input terminals for external f. m. or fine tuning or both.
 Input level: 1.5 V r. m. s. into 600 Ω for maximum frequency deviation.
 -1 V to -4 V for maximum fine frequency shift.

Amplitude modulation

Internal or external: ON/OFF square wave modulation. An internal squarer will square a sine wave input, or a square wave drive may be applied.
 Frequency: 630 Hz to 2 kHz.
 External input: 1.5 V r. m. s. or 4.5 V p-p into 600 Ω .
 A. M. on c. w. Greater than 60 dB down on 100% modulation, measured in a 20 kHz bandwidth.

Microphony

When checked on a mechanical vibrator, less than 12 kHz deviation is caused by $\frac{1}{2}$ g acceleration in the range of 10 to 80 Hz. (At 10 Hz, $\frac{1}{2}$ g corresponds to a displacement of 0.1 in.)

Each generator is checked on the mobile radio bands to ensure freedom from audio feedback between the receiver speaker and the generator, under normal working conditions.

Power requirements

A. C. supply (absolute limits) 95 V to 130 V }
 190 V to 264 V } 45 to 500 Hz

Load: 25 VA approx.

D. C. supply (absolute limits) 23 V to 32 V positive earth

Current 0.55 A, approx.

Current 0.35 A, approx. with crystal calibrator oven off.

Dimensions and weight

Height	Width	Depth	Weight
13 in (330 mm)	18 in (457 mm)	16 in (406 mm)	80 lb (36.4 kg)

1.3 ACCESSORIES

Accessories supplied.

Mains lead, TM 7052, 6 ft long; **mi** code 43122-017.

Link, 50 Ω type N male - type N male, connects DIRECT OUTPUT to ATTEN INPUT sockets; **mi** code 23443-787.

Set of accessories in box, TM 9130; **mi** code 46884-001, comprising:

- ① 6 dB pad, type N male - type N female; code 23448-865.
 - Impedance: 50 Ω .
 - Frequency range: D. C. to 1000 MHz.
 - Accuracy: ± 0.3 dB.
 - V. S. W. R.: Less than 1.1 : 1.
 - Maximum input: 1 W.
- ② Output Lead, TM 4726/12, 50 Ω type N male - type N male, 3 ft long; **mi** code 43125-046.
- ③ Output Lead, TM 4969/3, 50 Ω BNC male - BNC male, 5 ft long; **mi** code 43126-012.
- ④ Adapter, type N male - BNC female; **mi** code 23443-804.
- ⑤ Telephone jack plug, for crystal calibrator output socket; **mi** code 23421-612.
- ⑥ Extension Board, TM 8884, permits the instrument to be operated, for servicing, with any one of the plug-in circuit boards clear of the instrument; **mi** code 44815-106.
- ⑦ Extension lead, 12-way, feeds the supplies and inputs to an r. f. oscillator when operated clear of the instrument; **mi** code 43127-055.
- ⑧ Extension lead, coaxial, TNC male - TNC female, feeds the output from an r. f. oscillator when operated clear of the instrument; **mi** code 43126-036.

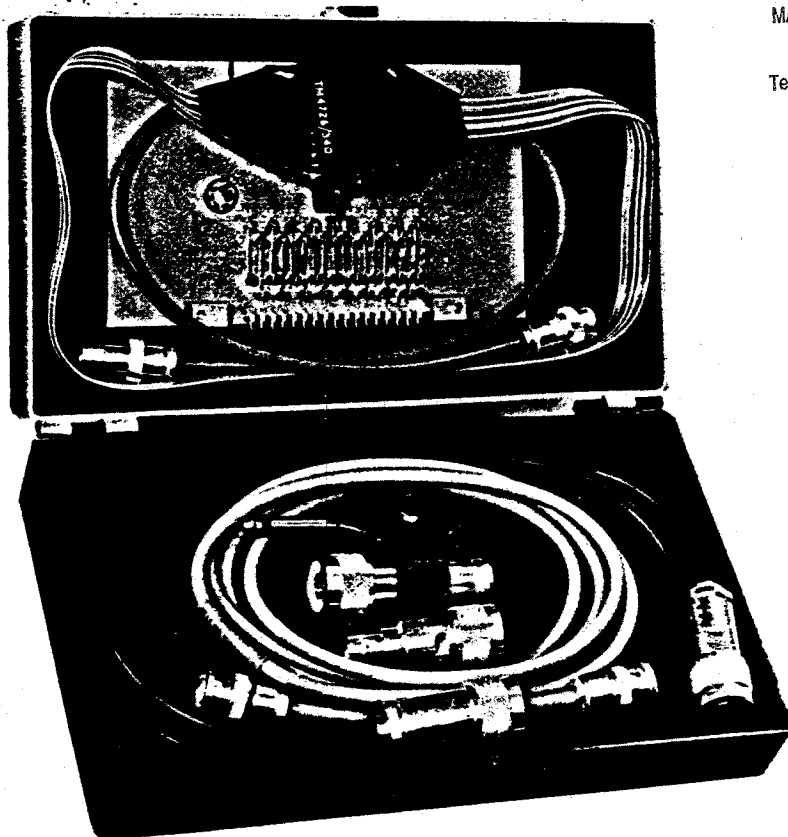

For Service Manuals Contact
MAURITRON TECHNICAL SERVICES
8 Cherry Tree Rd, Chinnor
Oxon OX9 4QY
Tel: 01844-351694 Fax: 01844-352554
Email: enquiries@mauritron.co.uk

Fig. 1.2 TM 9130 Set of Accessories

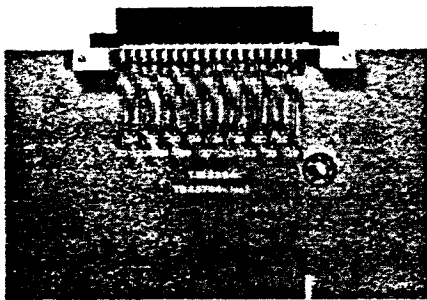
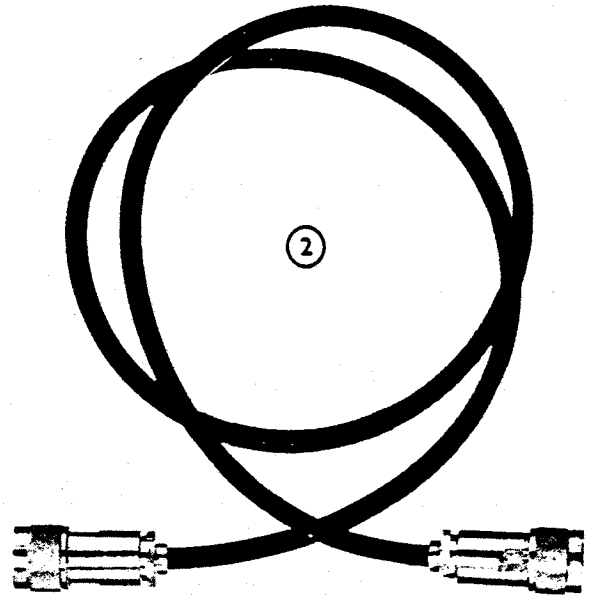
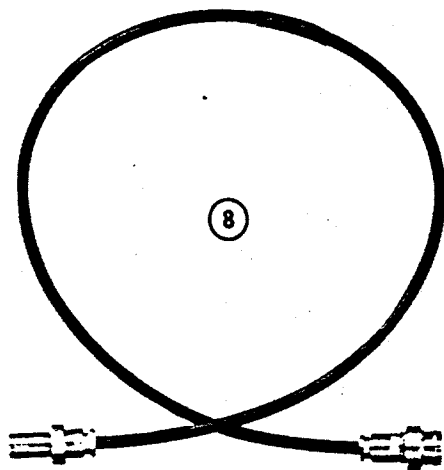

①



④

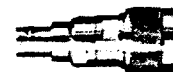

⑥

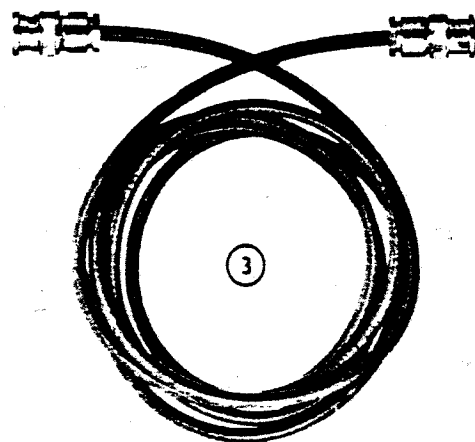
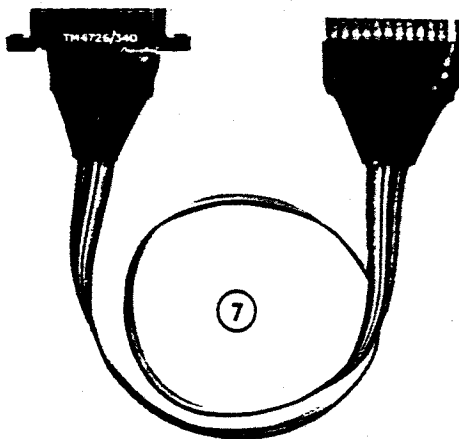

Fig. 1.3 Maintenance accessories

Fig. 1.4 Operation accessories

2.1 PREPARATION FOR USE

In common with other apparatus employing semiconductor devices, the performance of the instrument may be affected if it is subjected to excessive temperatures. Therefore completely remove the plastic cover, if one is supplied over the case, and avoid using the instrument standing on, or close to, other equipment that is hot.

As a protection against the hazard of shocks in transit, the tuning drive of each oscillator unit is turned to the high frequency end stop and the drive brake applied. You are recommended to take the same precautions when the instrument is transported in future.

A.C. power supply

Normally the instrument is supplied with the mains selector switch set for supply voltage within the range 190 to 260 V. For input voltages in the range 95 to 130 V the selector switch must be pressed to the left. Do this by removing the plate securing the switch button, pressing the switch to the correct position, reversing the plate and replacing it to hold the switch in the new position. For the 95 to 130 V range the 160 mA a.c. mains fuse must be replaced by a 250 mA fuse of the same type. See Sect. 5.7.

Attach a suitable 3 pin plug to the mains lead. Note the wires are colour coded as follows:

Earth (ground)	-	Green/Yellow
Neutral	-	Light Blue
Line (Phase)	-	Brown

In addition the earth wire carries a yellow sleeve bearing a green earth symbol and the neutral wire carries a sleeve marked N.

Connect to the supply and turn the SUPPLY Selector to A. C.

D.C. power supply

A d.c. supply of between 22 and 32 V, positive earthed, may be used. The current drain is about

550 mA, or 350 mA when the calibrator crystal oven is turned off.

Connect the supply by leads to the positive and negative terminals and turn the Supply selector to either of the d.c. positions. The first d.c. position gives normal operation, whilst at the second the crystal oven is switched off giving some loss of calibrator accuracy at the saving of 200 mA current drain.

Bench or rack mounting

Bench or rack mounting versions of the instrument are available; the latter version is designated TF 2006R.

To convert a bench version to rack mounting the front panel handles must be replaced by angle brackets, TM 9828, as follows.

- (1) Remove the case, as described in Sect. 4.2.
- (2) Remove the side handles (each is secured by nuts inside the case).
- (3) Remove the feet if there is to be other equipment below the signal generator in the rack.
- (4) Prise out the anodized aluminium strip from the recess on each handle to reveal three countersunk screws.
- (5) Extract the two plated pan head and the three countersunk head screws that secure each front panel handle and lift the handles away.
- (6) Attach the angle brackets in place of the handles using the same fixing holes. but longer screws in the countersunk positions.
- (7) Refit the case.

Before inserting a rack mounting instrument into a rack, slides or runners should be fitted to the rack to give support to the rear of the instrument, as the four retaining screws cannot be relied upon to bear its full weight.

The bench case has a retractable stand, which can be pulled down to tilt the front of the instrument up slightly.

Meter zeroing

Before turning the SUPPLY switch ON check that the pointers of the meters are at their extreme left-hand calibration mark (zero scale deflection). If necessary adjust the set screw at the top of each meter to bring the pointer to this position.

2.2 CONTROLS—SUPPLY, TUNING AND OUTPUT

① SUPPLY SWITCH. Controls d. c. and a. c. inputs.

② D. C. SUPPLY TERMINALS and FUSE.

③ SUPPLY SELECTOR. Selects a. c. input, d. c. input with, or d. c. input without the crystal calibrator oven connected.

④ A. C. SUPPLY PLUG and FUSE.

⑤ A. C. SUPPLY VOLTAGE SELECTOR.

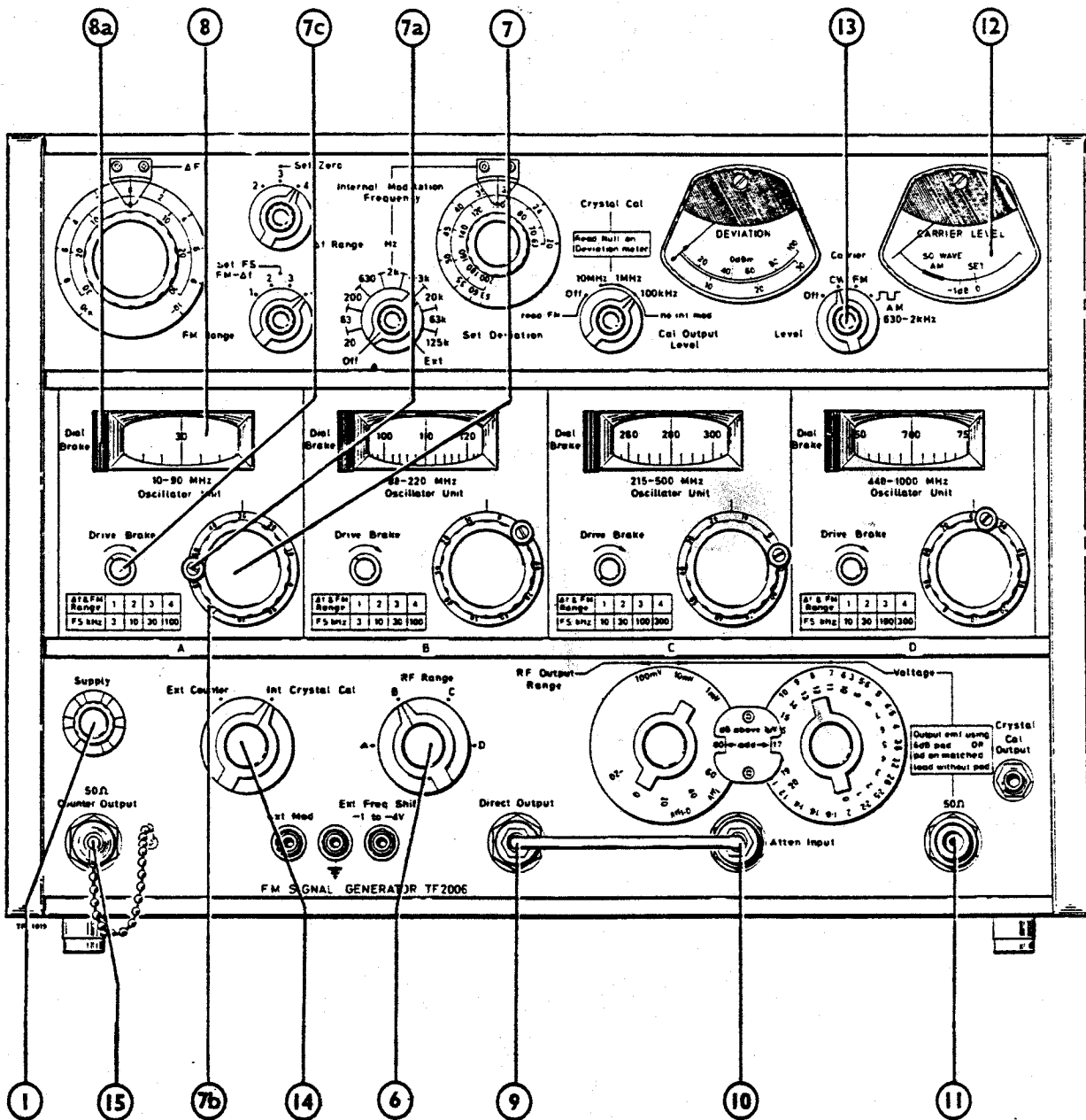

Fig. 2.1 Controls—supply, tuning and output

⑥ R. F. RANGE SWITCH. Selects which of the oscillator units shall be in use.

⑨ DIRECT OUTPUT SOCKET. Type N, 50 Ω. Connect by link to ATTENUATOR INPUT socket ⑩ when attenuated outputs are wanted.

⑦ FREQUENCY CONTROL. A separate control is provided for each oscillator unit.

⑩ ATTENUATOR INPUT SOCKET. Type N, 50 Ω.

⑦a HANDLE. To facilitate large changes of frequency.

⑪ R. F. OUTPUT SOCKET. Type N, 50 Ω. An output is available only when the ATTENUATOR INPUT ⑩ and DIRECT OUTPUT ⑨ sockets are linked.

⑦b LOGGING SCALE. Can be adjusted with respect to the control knob as an aid to resetting.

⑫ CARRIER LEVEL METER.

⑦c FREQUENCY DRIVE BRAKE. When turned clockwise the tuning drive is locked to prevent accidental disturbance of the setting.

⑬ CARRIER LEVEL CONTROL. Normally used to bring the CARRIER LEVEL meter to the reference mark.

⑧ FREQUENCY DIAL. A separate scale is provided for each oscillator unit.

⑭ SIGNAL MONITOR DIRECTOR. Turn clockwise when the crystal calibrator is to be used.

⑧a FREQUENCY DIAL BRAKE. When pressed in, a brake prevents the dial drum from turning so that the scale can be set up against a standard frequency.

⑮ COUNTER OUTPUT SOCKET. Type N, 50 Ω. In circuit only when ⑭ is set to EXT COUNTER.

⑯ MODULATION OSCILLATOR OUTPUT TERMINALS. Up to 0 dBm across 600 Ω is available from the modulation oscillator when it is switched on.

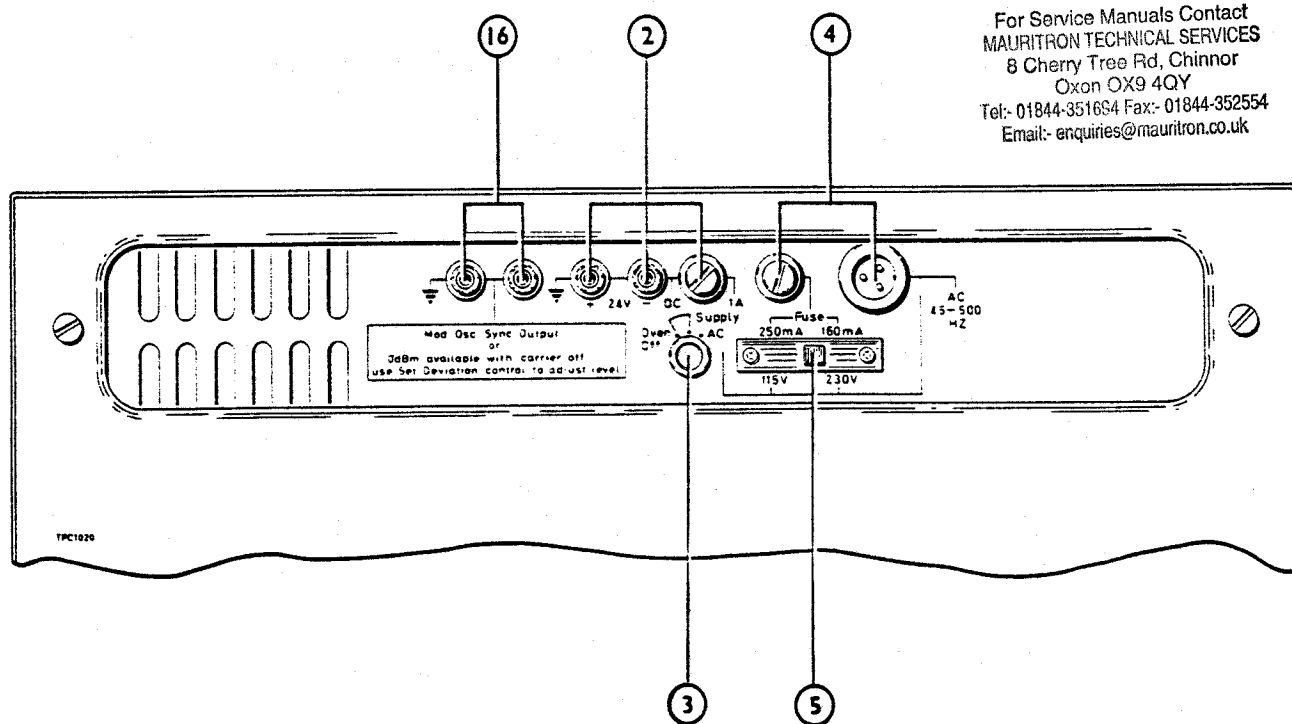

For Service Manuals Contact
 MAURITRON TECHNICAL SERVICES
 8 Cherry Tree Rd, Chinnor
 Oxon OX9 4QY
 Tel:- 01844-351684 Fax:- 01844-352554
 Email:- enquiries@mauritron.co.uk

Fig. 2.2 Controls—rear panel

2.3 CONTROLS—MODULATION, FINE TUNING AND CALIBRATOR

① Δf CONTROL. A calibrated fine tuning control. The sensitivity is given by the setting of the Δf RANGE SELECTOR ②.

②a Δf SCALE.

② ΔF RANGE SELECTOR. Selects the full scale value of frequency shift that will be produced by the frequency shift control ①. The available ranges 2, 3, 4 are identified in the table on each oscillator unit.

③ SET ZERO CONTROL. An uncalibrated fine tuning control.

④ SET FULL SCALE CONTROL. For making fine adjustments to the sensitivity of the frequency modulation and frequency shift amplifier.

⑤ F. M. RANGE SELECTOR. Selects the deviation range. The ranges are identified in the table on each oscillator unit.

⑥ SET DEVIATION CONTROL. Adjusts the deviation produced by the internal modulation oscillator or by a signal fed in at the EXTERNAL MODULATION terminal.

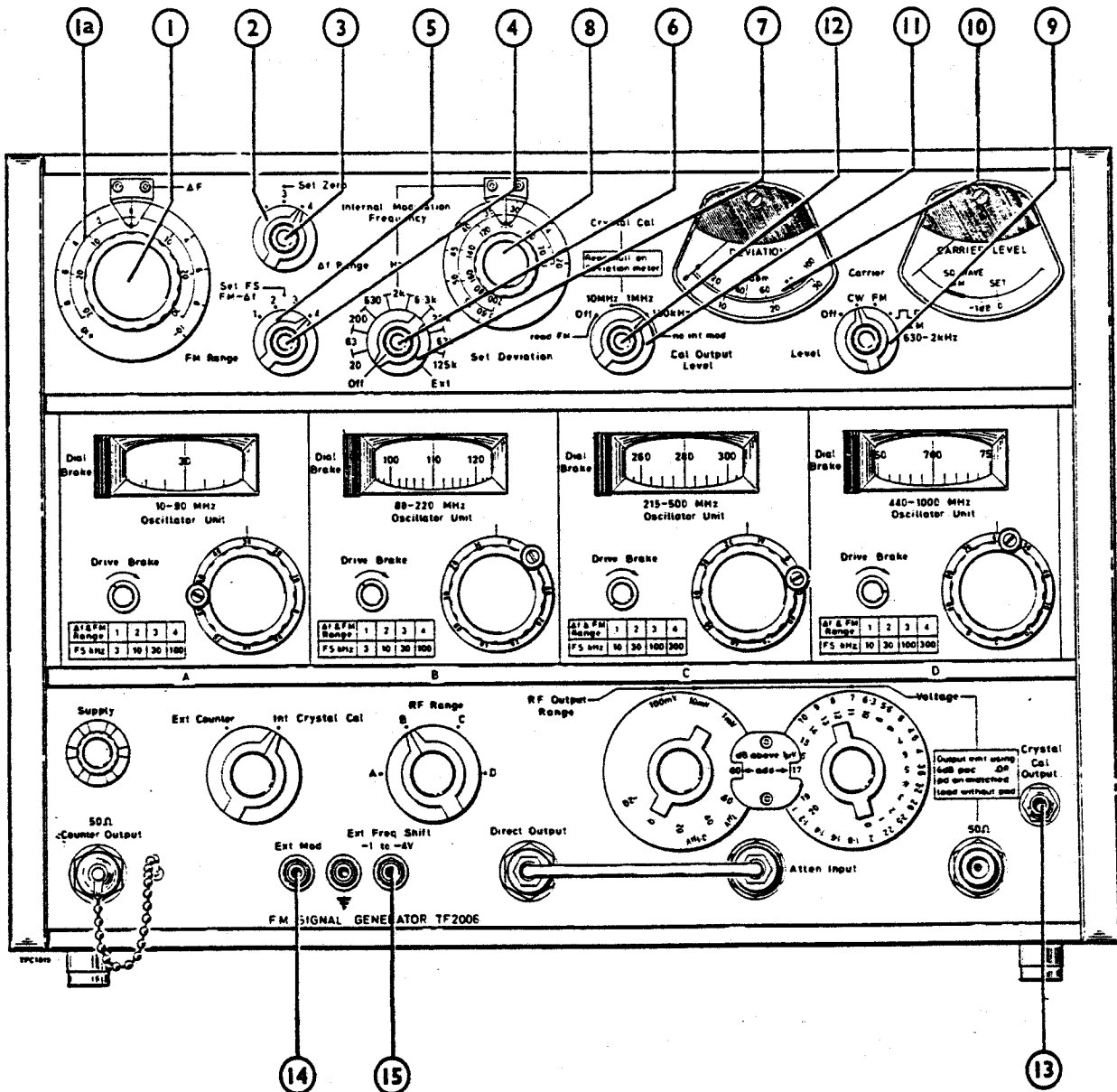

Fig. 2.3 Controls—modulation, fine tuning and calibrator

⑦ **MODULATION SELECTOR.** Selects one of the internal modulation frequency ranges or external modulation.

⑧ **MODULATION FREQUENCY CONTROL and SCALE.** A continuously variable internal modulation frequency control.

⑨ **CARRIER MODE SWITCH**

⑩ **MODULATION and CALIBRATOR MONITOR.** Reads deviation, scale sensitivity depends on the setting of the F. M. RANGE selector ⑤. When the crystal calibrator is in use the meter indicates the marker point nulls; when the carrier is switched off, the meter indicates the a. f. level fed to the modulation oscillator output terminals.

⑪ **MODULATION MONITOR AND CALIBRATOR SELECTOR.** Selects the intervals at which crystal calibrator points are provided. When the switch is turned to any of the crystal calibrator positions the internal modulation oscillator is stopped; external modulation is unaffected, but is not monitored by the deviation meter.

⑫ **CALIBRATOR OUTPUT LEVEL CONTROL.** Adjusts the level of beat note fed to the CRYSTAL CALIBRATOR OUTPUT socket ⑬. It does not affect the meter response.

⑬ **CRYSTAL CALIBRATOR OUTPUT SOCKET.** Output for driving headphones.

⑭ **EXTERNAL MODULATION TERMINAL.** 4 mm terminal, acts as inlet for external modulating signals above 20 Hz; either f. m. or a. m. according to the setting of the CARRIER MODE switch ⑨.

⑮ **EXTERNAL FREQUENCY SHIFT TERMINAL.** 4 mm terminal, acts as inlet for d. c. signals for frequency shift or low frequency a. c. signals for frequency modulation.

24 SETTING FREQUENCY

Turn the supply switch on. Although the instrument operates within seconds of switching on, to obtain the best frequency stability allow a stabilizing period.

Set the R. F. RANGE switch to the position that brings into use the oscillator unit covering the desired frequency. It is not necessary to allow any additional stabilizing time when changing r. f. ranges. Slacken the DRIVE BRAKE and adjust the

frequency control on the oscillator unit in use until the desired frequency appears against the cursor on the corresponding frequency scale. Now re-lock the frequency drive by turning the knob clockwise.

If the frequency scale is found to be in error with respect to some frequency standard, such as the internal crystal calibrator or an external counter, it may be adjusted as follows:

Unlock the frequency drive and tune the oscillator until a convenient datum line appears against the cursor. Lock the frequency dial by pressing in the DIAL BRAKE alongside the dial window. Retune the oscillator unit using the Frequency control until the frequency set on the dial is in agreement with the frequency standard used.

NOTE The amount of slip of the dial drum against the tuning drive is limited to about one turn of the Frequency control.

Crystal calibrator

Marker points at 10 MHz, 1 MHz or 100 kHz intervals can be chosen by the crystal calibrator selector switch. The calibrator markers are monitored by the deviation meter. As the instrument is tuned through a marker point, the deviation meter deflection rises to a maximum, falls to a null and then rises to a maximum again. The correct zero beat point is the null between the two maxima (see Fig. 2.3). An alternative a. f. output from the crystal calibrator is available at the crystal calibrator output socket. The output from this socket is adjusted by the calibrator output level control up to a maximum of about 230 mV e. m. f. The source impedance is also affected by this control, varying from 600 Ω at maximum down to zero.

To bring the crystal calibrator into use, turn the Signal Monitor Director in INT CRYSTAL CAL. To avoid ambiguity owing to the accuracy limitation of the main frequency scale, firstly set the crystal calibrator selector to 10 MHz. If the 4 - 10 MHz oscillator unit is in use the initial setting should be for 1 MHz intervals. Tune the oscillator unit approximately to the marker frequency nearest the desired carrier frequency and adjust the appropriate frequency control for null on the deviation meter by switching the calibrator selector switch in turn to 1 MHz and 100 kHz marker intervals, advancing the appropriate frequency control and counting the marker points as they are observed. By this procedure it is possible to set the frequency of the signal generator to any 100 kHz point.

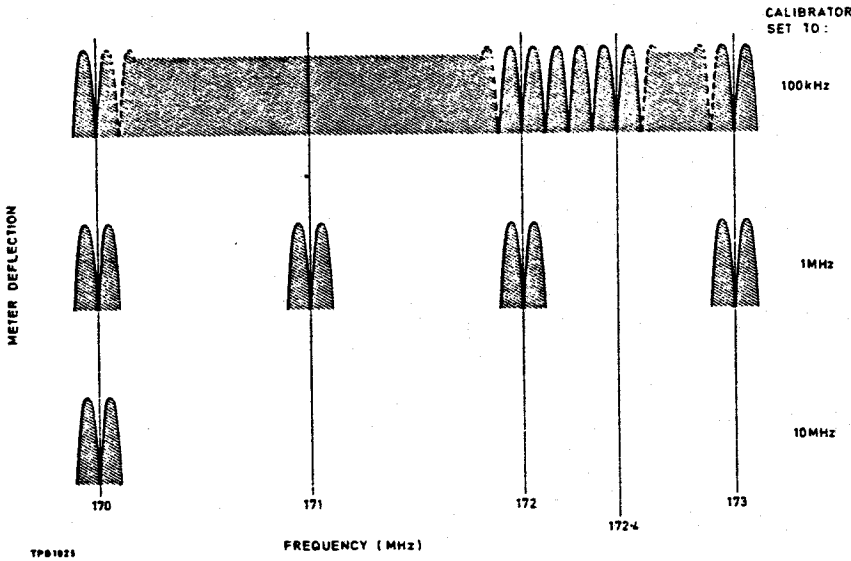

Fig. 2.4 Crystal calibrator markers

For Service Manuals Contact
 MAURITRON TECHNICAL SERVICES
 8 Cherry Tree Rd, Chinnor
 Oxon OX9 4QY
 Tel:- 01844-351694 Fax:- 01844-352554
 Email:- enquiries@mauritron.co.uk

Example: To tune the signal generator to a frequency of 172.4 MHz, turn the R. F. RANGE switch to bring into use the 88 - 220 MHz oscillator unit and adjust its frequency control until the 170 MHz point on the scale is against the cursor. Turn the Signal Monitor Director to INT CRYSTAL CAL and the Crystal Calibrator Selector to 10 MHz. Slightly readjust the oscillator Frequency control until the null point is observed on the deviation meter. Reset the Crystal Calibrator Selector to 1 MHz and advance the Frequency control past the 170 MHz marker and then past the 171 MHz marker and stop at the 172 MHz null point. Reset the Crystal Calibrator Selector to 100 kHz and advance the Frequency control away from the 172 MHz point and past the first three 100 kHz markers (172.1, 172.2 and 172.3 MHz) and stop at the null point of the fourth.

white line on the knobs uppermost, the ΔF control can be used to an accuracy of about 10% without any preliminary setting up.

Table 2.1

Carrier frequency range (MHz)	ΔF range	2	3	4
		Full scale ΔF (kHz)		
88 - 220	4 - 10	10	30	100
	10 - 90	10	30	100
	88 - 220	10	30	100
	215 - 500	30	100	300
	440 - 1000	30	100	300

Counter

If the signal generator is to be used with a counter type frequency meter turn the Signal Monitor Director to EXT COUNTER and connect the counter to the COUNTER OUTPUT socket. See also Sect. 2.7 - counter output.

Fine tuning

Electrical fine tuning upwards and downwards in frequency, can be obtained with the ΔF control. This has three ranges that are chosen by the ΔF RANGE selector. The ranges have full-scale values that depend on the oscillator unit in use as shown in Table 2.1. With the SET ZERO and the SET FULL SCALE controls at their datum marks i. e. with the

To obtain a higher order of accuracy, the ΔF control must be standardized against the crystal calibrator or an external counter. To do this, tune the signal generator roughly to the frequency at which it is to be used and set the ΔF control to zero. Turn the ΔF RANGE selector to the position that gives 100 kHz full-scale sensitivity and set the crystal calibrator selector to 100 kHz. Adjust the tuning using the frequency control of the oscillator unit in use and the SET ZERO control until the Modulation and Calibrator Monitor indicates a null. Turn the ΔF control to either +10 or -10 on the outer scale and adjust the SET FULL SCALE control so that the Modulation and Calibrator Monitor indicates a null.

With the 215 - 500 MHz and 440 - 1000 MHz r. f. ranges, the ΔF control can be standardized

also at 300 kHz, against the third calibrator null from the zero position.

When thus standardized, frequency increments with an accuracy of up to $\pm 2\%$ can be produced at any setting of ΔF RANGE selector in the direction that was chosen for the standardization. The accuracy depends upon the ΔF range as shown in Table 2.2.

Table 2.2

ΔF range (kHz)	Accuracy (kHz)
300	± 6
100	± 2
30	± 1.5
10	± 1

Example: To tune the signal generator to a frequency of 172.452 MHz, carry out the procedure previously described for the crystal calibrator, if necessary using the SET ZERO control to reach the final null precisely. Turn the ΔF RANGE selector to 4 (100 kHz) and the ΔF control to +10 noting whether a null is passed on the Modulation and Calibrator Monitor. Adjust the SET Full Scale control to bring the frequency back to the null if one has passed or, if not, to bring the frequency forward to the next null. The ΔF control is now standardized for positive frequency shift. Finally turn the ΔF control to -5.2.

External frequency shift

Frequency shift can be obtained by applying a voltage between the EXTERNAL FREQUENCY SHIFT terminal and earth. The terminal has a standing potential of -2.5 V and requires a variation between not more than -1 V and -4 V to give the maximum shift specified for each oscillator unit. The sense of operation is such that voltages less negative than -2.5 V increase the frequency whilst voltages more negative than -2.5 V decrease the frequency.

Neither the ΔF control nor the SET DEVIATION control affects inputs to this terminal but the F. M. RANGE selector does control sensitivity. The facility is intended chiefly for d. c. inputs for such applications as simulating a frequency shift keyed signal. However, a. c. inputs also can be applied to the EXTERNAL FREQUENCY SHIFT terminal when very low modulating frequencies are used or when minimum phase shift must be achieved, but the deviation will not be monitored accurately unless the frequency is greater than 20 Hz.

Logging scale

Each frequency control has a moveable skirt, engraved 0 - 100, that can be used either simply as an aid to resetting or as a means of achieving known frequency shifts larger than are available from the electrical system when, for example, measurements are to be made on wide bandwidth equipment.

Although the tuning law of each oscillator is approximately linear, the logging scale must be calibrated near to the range of frequencies at which it is to be used. Calibration can be easily done using the crystal calibrator. If the number of logging scale divisions between adjacent 10 MHz or 1 MHz calibrator points is noted, the frequency change per division can be calculated. This calibration can be considered to remain sufficiently constant over 300 logging scale divisions (3 turns of the knob).

2.5 FREQUENCY MODULATION

Internal

To obtain frequency modulation by the internal oscillator:

- (1) Set the Modulation Selector to the position corresponding to the frequency range that includes the desired modulating frequency. Each switch position that gives internal modulation falls between two figures, which indicate in Hz the frequency limits of the band obtained at that position.

NOTE: On the highest frequency range, marked 63k - 125k, the oscillator does function up to 200 kHz but the maximum usable frequency is limited to 125 kHz by the bandwidth of the modulating circuits.

- (2) Turn the MODULATION FREQUENCY control so that the scale indicates the desired frequency.
- (3) Turn the CARRIER Mode switch to F. M.
- (4) Turn the Modulation Monitor and Calibrator Selector to READ F. M. (OFF).
- (5) Select the deviation with the F. M. RANGE selector and the SET DEVIATION control. Deviation is indicated by the Modulation and Calibrator Monitor within the range corresponding to the setting of the F. M. RANGE selector. The f. m. range sensitivities depend on carrier frequency range and are given on the front panel of the oscillator units and in Table 2.3.

Table 2.3

Carrier frequency range (MHz)	F. M. range		Full scale deviation (kHz)			
	1	2	3	4		
Carrier frequency range (MHz)	4 - 10	3	10	30	100	
	10 - 90	3	10	30	100	
	88 - 220	3	10	30	100	
	215 - 500	10	30	100	300	
	440 - 1000	10	30	100	300	

Deviation accuracy up to 12% can be obtained without standardization. If higher accuracy is wanted (up to ±6%), standardize the modulator using a similar method to that described in Sect. 2.4 - fine tuning, but allow for any difference of sensitivity between positive and negative excursions.

Turn the RANGE selector to the position that gives 100 kHz sensitivity and turn the ΔF control to either +10 or -10. (Choose the more sensitive direction.) Adjust the SET FULL SCALE control so that the Modulation and Calibrator Monitor indicates a null. Swing the ΔF control to the opposite end of its range to find the position of the corresponding 100 kHz null, and continue turning until the control is midway between this point and the 10 calibration mark. Slightly readjust the SET FULL SCALE control so that the Modulation and Calibrator Monitor indicates a null.

With the 215-500 and 440-1000 MHz r. f. ranges, the deviation can be standardized also on its 300 kHz range, against the third calibrator null from the zero position.

Fine tuning and frequency modulation can be used simultaneously, provided the peak excursion does not exceed 100 kHz at carrier frequencies below 215 MHz or 300 kHz above 215 MHz, but the deviation accuracy will be impaired.

External

Frequency modulating signals may be applied to the EXT MOD terminal which requires an input up to 1.5 V r. m. s. into 600 Ω. The deviation is controlled both by the F. M. RANGE selector and the SET DEVIATION control as with internal modulation. It is also possible to frequency modulate the generator with a signal applied to the EXT FREQ SHIFT terminal.

To obtain external frequency modulation:

- (1) Set the Modulation Selector to EXT.

- (2) Turn the CARRIER Mode selector to F. M.

- (3) Turn the Modulation Monitor and Calibration Selector to READ F. M. (OFF). Although the modulation circuits function in the other positions of the selector, the deviation is not monitored.

- (4) Select the deviation with the F. M. RANGE selector and the SET DEVIATION control (inputs to EXT MOD terminal only).

Deviation is indicated by the Modulation and Calibrator Monitor for inputs to either terminal within the frequency range 20 Hz to 125 kHz. The f. m. range sensitivities depend on the carrier frequency range and are given on the front panel of the oscillator units and in Table 2. 2.

2.6 AMPLITUDE MODULATION

Simple square wave amplitude modulation to a depth of 100% is produced by effectively switching the carrier on and off. The modulating frequencies are limited to the range 630 Hz - 2 kHz.

Internal

To obtain square wave a. m. by the internal oscillator:

- (1) Turn the Modulation Selector to 630 - 2k.
- (2) Turn the MODULATION FREQUENCY control so that the scale indicates the desired frequency.
- (3) Turn the CARRIER Mode switch to A. M.

When amplitude modulation is used the CARRIER LEVEL meter reading should fall to within the black segment.

External

Signals applied to the EXT MOD terminal can be used to amplitude modulate the generator output. The input required is 1.5 V r. m. s. or 4.5 V p-p. The exact waveform is unimportant as an internal squarer circuit can accept sine or square wave inputs.

To obtain square wave a. m. from an external signal:

- (1) Turn the Modulation Selector to EXT.
- (2) Turn the CARRIER Mode selector to A. M.
- (3) Connect the signal to the EXT MOD terminal.

2.7 SETTING OUTPUT

With the CARRIER Mode switch at C.W. or F.M., bring the pointer of the CARRIER LEVEL meter to SET. For square wave modulation the CARRIER LEVEL control should not be readjusted from the c.w. position. The CARRIER LEVEL meter will indicate within the black segment and the level of the square wave when on will be equal to the c.w. level.

Direct output

A level of 100 mV p.d. across 50 Ω appears at the DIRECT OUTPUT socket when the CARRIER LEVEL meter is at SET. Because the r.f. level monitor is compensated for insertion of the attenuator, the level at this socket rises by about 0.3 dB per 100 MHz from the low frequency value. Only the CARRIER LEVEL control affects the voltage at the DIRECT OUTPUT socket.

Attenuated output

When the attenuator is to be used, connect the link between the DIRECT OUTPUT socket and the ATTEN INPUT socket, taking the output from the R.F. Output socket.

The output levels read from the attenuator dials are those which appear across a matching (50 Ω) load. The attenuators are also direct reading in terms of source e.m.f. when the output is fed through the 6 dB pad which is supplied as an accessory.

Expressed in dB referred to 1 μ V

With the CARRIER LEVEL meter at SET, the output level is the sum of the readings of the dB scales of the coarse and fine attenuators. The fine attenuator allows level adjustment in 1 dB steps but intermediate outputs can be obtained by varying the setting of the CARRIER LEVEL control.

If the CARRIER LEVEL meter is not at SET subtract its reading (in dB) from the output indicated by the attenuator dials.

Expressed in volts

With the CARRIER LEVEL meter at SET the output voltage is indicated on the fine attenuator dial within the decade shown on the coarse attenuator dial.

For Service Manuals Contact
MAURITRON TECHNICAL SERVICES
8 Cherry Tree Rd, Chinnor
Oxon OX9 4QY
Tel:- 01844-351694 Fax:- 01844-352554
Email:- enquiries@mauritron.co.uk

Counter output

For applications such as operating a counter type frequency meter, an alternative output is provided.

Part of the output signal from the oscillators is diverted to the COUNTER OUTPUT socket. The level is affected by the setting of the CARRIER LEVEL control and any modulation of the principal signal is also applied to the counter output. But the level is independent of the setting of the attenuators.

The output level into 50 Ω is at least 100 mV up to 600 MHz and 50 mV up to 1000 MHz.

When not in use, fit the cap to the COUNTER OUTPUT socket to keep r.f. leakage to a minimum.

2.8 MISMATCHED LOADS

The r.f. output circuit of the signal generator should be regarded as a zero impedance voltage source in series with a resistance of 50 Ω . This is shown in Fig. 2.5 where:

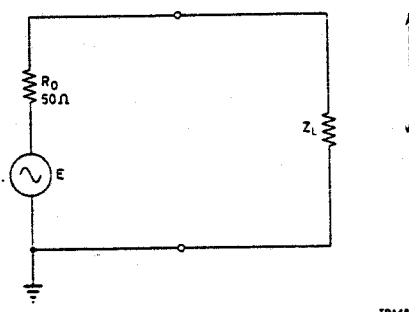

Fig. 2.5 Equivalent output circuit

E is the indicated source e.m.f.

R_o is the source resistance

Z_L is the external load impedance

V_L , the voltage developed across the load is given by

$$V_L = E \frac{Z_L}{R_o + Z_L}$$

or, for purely resistive loads

$$V_L = E \frac{R_L}{R_o + R_L}$$

Table 2.4 shows the conversion factors for obtaining the load voltage from the indicated e. m. f. at different load impedances.

When using a correctly matched, i. e. 50 Ω, output lead its output end can be regarded as an extension to the output socket on the generator and wide variations of load impedance do not seriously affect the calculated load voltage obtained from Table 2.4. Standing waves produced by the mismatched load can, for most purposes, be ignored.

To make the attenuator dials direct reading in terms of e. m. f., use the 6 dB pad supplied at the load end of the output lead. This will also ensure that the lead is correctly terminated and attenuate any extraneous noise induced in it.

Matching to high impedance loads

To present a load that is greater than 50 Ω with a signal derived from a matched source, a resistor R_s is added in series with the generator output. The value of R_s is given by the difference between the load and the generator impedances, that is

$$R_s = R_L - R_o$$

The voltage across the load, V_L , is given by

$$V_L = \frac{E}{2}$$

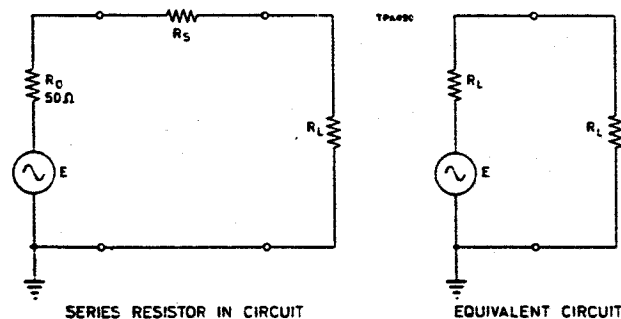

Fig. 2.6 High impedance matching

Matching to low impedance loads

To present a load that is less than 50 Ω with a signal derived from a matched source, a resistor R_p is added in parallel with the generator output. The value of R_p is given by

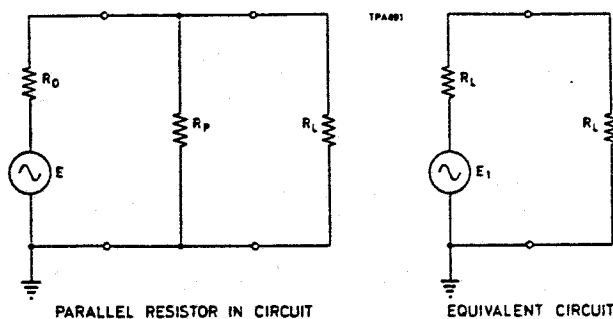

Fig. 2.7 Low impedance matching

$$R_p = \frac{R_o R_L}{R_o - R_L}$$

The effective source e. m. f. is now different and is given by

$$E_1 = E \frac{R_p}{R_o + R_p}$$

and the voltage across the load, V_L , is given by

$$V_L = \frac{E_1}{2}$$

Matching to balanced loads

Equipment whose input circuit is in the form of a balanced winding can be fed from the generator by using two series resistors as shown in Fig. 2.7. This method makes use of the auto-transformer effect of the centre-tapped winding and is not suitable for resistive balanced loads.

The values of R_1 (for use in the centre conductor) and R_2 (for the earth lead) are given by

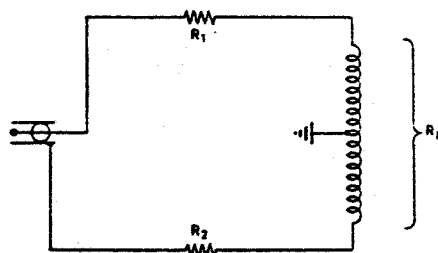

Fig. 2.8 Balanced load matching

$$R_1 = \frac{R_L}{2} - 50$$

$$R_2 = \frac{R_L}{2}$$

2.9 A.F. OUTPUT

An output from the modulation oscillator is brought to terminals at the rear of the instrument

for use as a synchronizing signal or as a general purpose a. f. source.

This output is available only when the Modulation Monitor and Calibrator selector is set to OFF (READ F. M.).

When the CARRIER Mode selector is set to OFF the a. f. output level is monitored by the Modulation and Calibrator Monitor; the SET DEVIATION control can be used to bring it to 0 dBm into 600 Ω (778 mV). When the CARRIER Mode selector is set to F. M. or \square A. M. the output level is not monitored but is approximately 1 V e. m. f.

Table 2.4

To find load voltage:

Load ohms	Multiply e.m.f. by	or subtract dB	Load ohms	Multiply e.m.f. by	or subtract dB
10	0.167	15.5	100	0.67	3.5
20	0.286	10.9	120	0.71	3.0
30	0.375	8.5	150	0.75	2.5
40	0.445	7.0	200	0.80	1.9
50	0.50	6.0	300	0.86	1.3
60	0.55	5.2	500	0.91	0.8
70	0.58	4.7	600	0.92	0.7
75	0.60	4.4	800	0.94	0.5
80	0.62	4.2	1000	0.95	0.4
90	0.64	3.8	2000	0.98	0.2
			4000	0.99	0.1

For Service Manuals Contact
 MAURITRON TECHNICAL SERVICES
 8 Cherry Tree Rd, Chinnor
 Oxon OX9 4QY
 Tel:- 01844-351694 Fax:- 01844-352554
 Email:- enquiries@mauritron.co.uk

Decibel conversion table

Ratio Down		DECIBELS	Ratio Up	
VOLTAGE	POWER		VOLTAGE	POWER
1-0	1-0	0	1-0	1-0
·9886	·9772	·1	1-012	1-023
·9772	·9550	·2	1-023	1-047
·9661	·9333	·3	1-035	1-072
·9550	·9120	·4	1-047	1-096
·9441	·8913	·5	1-059	1-122
·9333	·8710	·6	1-072	1-148
·9226	·8511	·7	1-084	1-175
·9120	·8318	·8	1-096	1-202
·9016	·8128	·9	1-109	1-230
·8913	·7943	1-0	1-122	1-259
·8710	·7586	1-2	1-148	1-318
·8511	·7244	1-4	1-175	1-380
·8318	·6918	1-6	1-202	1-445
·8128	·6607	1-8	1-230	1-514
·7943	·6310	2-0	1-259	1-585
·7762	·6026	2-2	1-288	1-660
·7586	·5754	2-4	1-318	1-738
·7413	·5495	2-6	1-349	1-820
·7244	·5248	2-8	1-380	1-905
·7079	·5012	3-0	1-413	1-995
·6683	·4467	3-5	1-496	2-239
·6310	·3981	4-0	1-585	2-512
·5957	·3548	4-5	1-679	2-818
·5623	·3162	5-0	1-778	3-162
·5309	·2818	5-5	1-884	3-548
·5012	·2512	6	1-995	3-981
·4467	·1995	7	2-239	5-012
·3981	·1585	8	2-512	6-310
·3548	·1259	9	2-818	7-943
·3162	·1000	10	3-162	10-000
·2818	·07943	11	3-548	12-59
·2512	·06310	12	3-981	15-85
·2239	·05012	13	4-467	19-95
·1995	·03981	14	5-012	25-12
·1778	·03162	15	5-623	31-62

Decibel conversion table (continued)

Ratio Down			Ratio Up	
VOLTAGE	POWER	DECIBELS	VOLTAGE	POWER
-1585	-02512	16	6.310	39.81
-1413	-01995	17	7.079	50.12
-1259	-01585	18	7.943	63.10
-1122	-01259	19	8.913	79.43
-1000	-01000	20	10.000	100.00
-07943	6.310×10^{-3}	22	12.59	158.5
-06310	3.981×10^{-3}	24	15.85	251.2
-05012	2.512×10^{-3}	26	19.95	398.1
-03981	1.585×10^{-3}	28	25.12	631.0
-03162	1.000×10^{-3}	30	31.62	1,000
-02512	6.310×10^{-4}	32	39.81	1.585×10^3
-01995	3.981×10^{-4}	34	50.12	2.512×10^3
-01585	2.512×10^{-4}	36	63.10	3.981×10^3
-01259	1.585×10^{-4}	38	79.43	6.310×10^3
-01000	1.000×10^{-4}	40	100.00	1.000×10^4
7.943×10^{-3}	6.310×10^{-5}	42	125.9	1.585×10^4
6.310×10^{-3}	3.981×10^{-5}	44	158.5	2.512×10^4
5.012×10^{-3}	2.512×10^{-5}	46	199.5	3.981×10^4
3.981×10^{-3}	1.585×10^{-5}	48	251.2	6.310×10^4
3.162×10^{-3}	1.000×10^{-5}	50	316.2	1.000×10^5
2.512×10^{-3}	6.310×10^{-6}	52	398.1	1.585×10^5
1.995×10^{-3}	3.981×10^{-6}	54	501.2	2.512×10^5
1.585×10^{-3}	2.512×10^{-6}	56	631.0	3.981×10^5
1.259×10^{-3}	1.585×10^{-6}	58	794.3	6.310×10^5
1.000×10^{-3}	1.000×10^{-6}	60	1,000	1.000×10^6
5.623×10^{-4}	3.162×10^{-7}	65	1.778×10^3	3.162×10^6
3.162×10^{-4}	1.000×10^{-7}	70	3.162×10^3	1.000×10^7
1.778×10^{-4}	3.162×10^{-8}	75	5.623×10^3	3.162×10^7
1.000×10^{-4}	1.000×10^{-8}	80	1.000×10^4	1.000×10^8
5.623×10^{-5}	3.162×10^{-9}	85	1.778×10^4	3.162×10^8
3.162×10^{-5}	1.000×10^{-9}	90	3.162×10^4	1.000×10^9
1.000×10^{-5}	1.000×10^{-10}	100	1.000×10^5	1.000×10^{10}
3.162×10^{-6}	1.000×10^{-11}	110	3.162×10^5	1.000×10^{11}
1.000×10^{-6}	1.000×10^{-12}	120	1.000×10^6	1.000×10^{12}
3.162×10^{-7}	1.000×10^{-13}	130	3.162×10^6	1.000×10^{13}
1.000×10^{-7}	1.000×10^{-14}	140	1.000×10^7	1.000×10^{14}

For Service Manuals Contact
MAURITRON TECHNICAL SERVICES
8 Cherry Tree Rd, Chinnor
Oxon OX9 4QY
Tel: 01844-351694 Fax: 01844-352554
Email: enquiries@mauritron.co.uk

Technical description

Each of the printed boards and other sub-assemblies in this instrument has been allocated an identification number in the sequence ① to ④, which wherever practicable is marked upon it. The complete circuit reference for a component carries its unit number as a prefix, e.g. 6R15.

For convenience in this chapter and on the circuit diagrams, the circuit reference is abbrevi-

ated by dropping the prefix, except where there is risk of ambiguity.

3.1 CIRCUIT SUMMARY

Each r. f. range has a completely separate oscillator and associated modulator circuits, which are housed in a self-contained assembly. Five

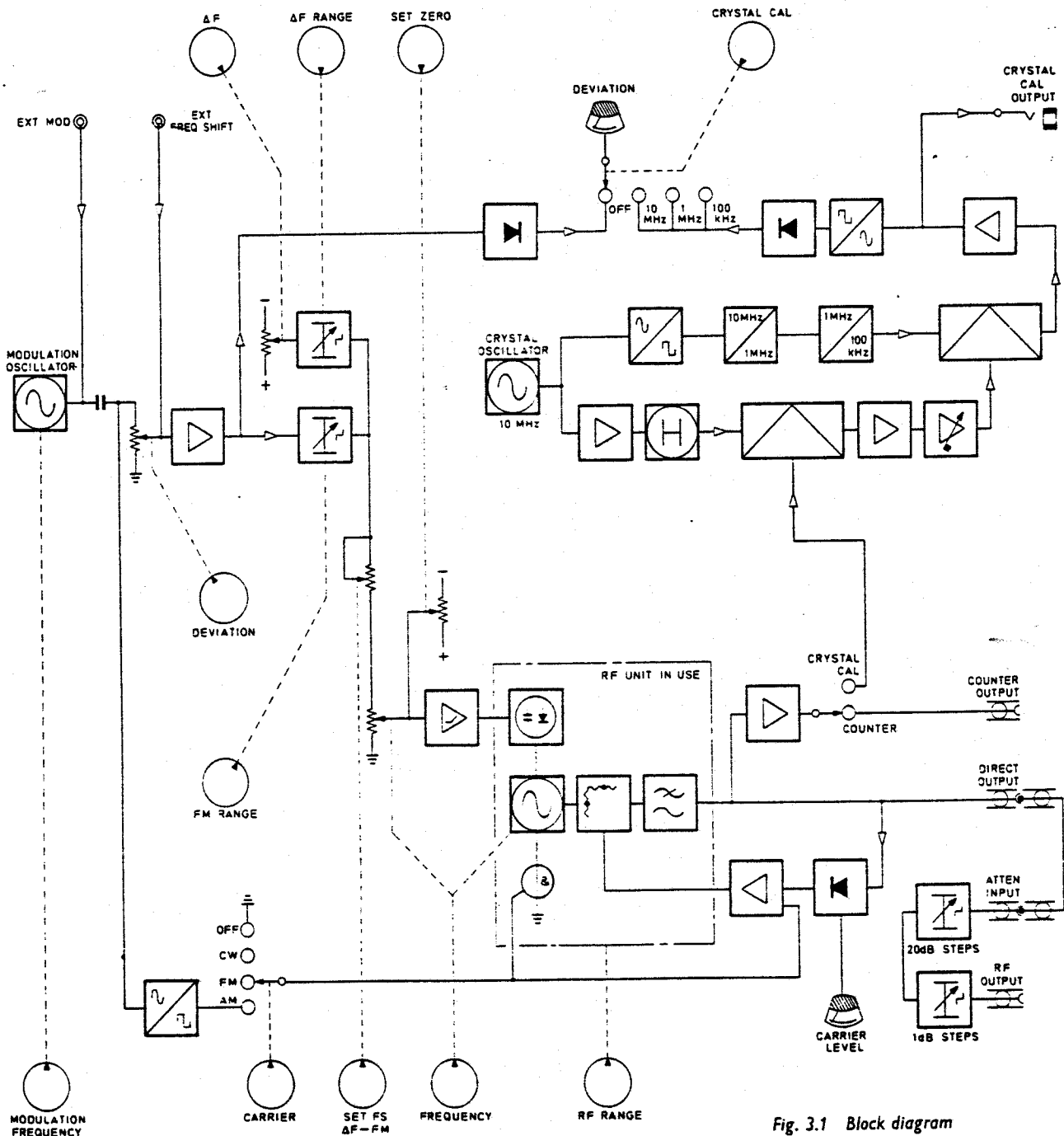

Fig. 3.1 Block diagram

different r. f. oscillator assemblies are available, covering the frequency range 4 MHz to 1000 MHz, but not more than four can be fitted to an instrument at a time. The frequency coverage of any instrument, then, depends on whether the full complement of four oscillators is fitted and on which ones are chosen.

To reduce frequency drift upon range changing, the oscillators continue to receive power when not in use; they are switched off by shunting the tuned circuit with a forward biased diode. The same diode is used to provide square wave amplitude modulation.

The output level from each oscillator is kept constant by an L pad of thermistors whose attenuation is controlled by a bias current.

A varactor diode across each tuned circuit provides the means of both fine tuning and frequency modulation. The drive circuitry is common to both functions and provides compensation for the inherent non-linearity of the varactor and for the change of sensitivity with carrier frequency. Internal modulating signals are provided by a variable frequency Wien bridge oscillator or external signals can be used.

Frequency may be monitored by means of an external counter or by the internal crystal calibrator system.

Coarse and fine stepped attenuators are provided, each using resistive π pads selected by cam operated microswitches.

3.2 OSCILLATORS

Each oscillator assembly consists of two castings bolted together carrying in various compartments the oscillatory circuit, modulating and switching circuits and filtering components.

To achieve good freedom from microphonic modulation the tuning capacitor is constructed in the form of a plunger with a conical hole which mates with a corresponding tapered end of the tuning inductor. The plunger slides in an earthed bearing block forming a capacitor to earth. The dielectric for this capacitor is the aluminium oxide layer produced by anodizing the plunger.

As the plunger moves in and out both the spacing between it and the fixed part of the capacitor, as well as their overlap, varies giving a square law capacitance change and consequently a near linear frequency law.

For all the frequency ranges above 90 MHz the circuit is arranged as a Clapp oscillator, the tuning inductor being a half-wavelength line.

440-1000 MHz oscillator

The tuned circuit consists of 25L16 in series with 25C30. 25C29 is very large compared with 25C30 and is formed between the plunger and the bearing block. 25C27 shunts the tuned circuit and is formed by the back plate of the oscillator unit and the rear face of 25L16. Ceramic washers separate the components of this assembly, which is held together by nylon screws. Two transistors are used in parallel; resistors in the collectors prevent interaction between them. The Colpitts capacitors are provided by the stray collector-emitter and base-emitter capacitance of the transistors. A d. c. return path for the collectors is provided by 25L15 which is wound with a resistive wire to develop a bias voltage for the clamping diode, 21MR1.

To keep frequency drift as low as possible the current feed to the transistors is not disconnected when another range is in use. A clamping diode, 21MR1 is connected across the tuned circuit and a control voltage biases it either to a low impedance, forward conducting, condition to damp the tuned circuit and prevent oscillation, or to a high impedance, non-conducting, condition when the oscillator output is required.

The same components produce square wave modulation; a square wave drive signal is applied to the diode, which alternately turns the oscillator on and off, thus producing 100% square wave modulation.

Frequency modulation and frequency shift for fine tuning are produced by a varactor diode, a diode whose capacitive reactance varies with applied bias, connected across the tuned circuit. The varactor is coupled to the tuned circuit by capacitors 25C25 and 25C26 which are formed by areas of copper on both sides of the piece of board that it is mounted on.

Output from the oscillator is taken by a coupling loop, 27L4, and fed via an L pad of thermistors, TH1 and TH2, mounted on board (27). These thermistors form the control element in the a. l. c. system described in Sect. 3.3. Board (27) carries also a low-pass filter to remove spurious signals generated by resonance of the cavity surrounding the tuned circuit; printed components and sections of transmission line are used.

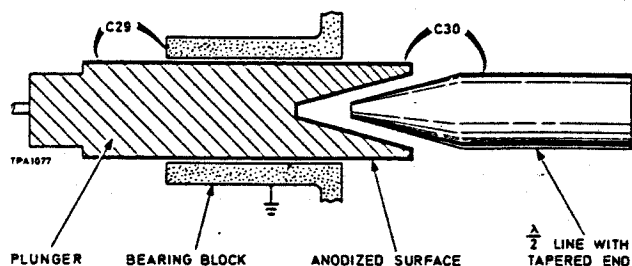

Fig. 3.2 Tuning components for 215-500 MHz and 440-1000 MHz ranges

The half-wavelength line and the variable capacitor are contained in a central cavity in the casting. Separate screened compartments are provided for the other oscillator components, the supply and input filters and for the level control and output filter board. An open compartment on the underside of the casting carries the tracking network that forms part of the frequency modulation and frequency shift drive circuits described in Sect. 3.5.

215-500 MHz oscillator

This oscillator is similar to the 440 - 1000 MHz version. The tuned circuit consists of 21L13 and 21C30 shunted by 21C27. The Colpitts capacitors are provided by the stray base-emitter and collector-emitter capacitance supplemented by 22C4 and 22C5.

88-220 MHz oscillator

The principle of tuning used for this range is unchanged, but the half-wavelength line consists of a tape wound as a helix on a ceramic rod and connected to the fixed part of 17C31. Only one transistor is needed to sustain oscillation at these frequencies. Separate Colpitts capacitors are used; 17C23 and 17C24 are printed components whilst 17C25 is a ceramic disk type.

10-90 MHz oscillator

Special tuning arrangements are needed for this range with its 9 to 1 coverage and lower frequency. A similar method of capacitance variation is used but a double taper is used to give two variable capacitors, 12C27 which tunes the oscillator and 12C28 which alters the coupling of the varactor. In addition to the variable capacitor, permeability tuning is applied to the inductor, 12L11. The two transistors, 13VT1 and 13VT2, are arranged to form a push-pull oscillator with the tuned circuit.

Output is taken via the coupling coil, 12L12, and fed to a buffer amplifier, 14VT1, arranged in common base configuration.

4-10 MHz oscillator

The lowest frequency oscillator range uses a Colpitts oscillator arranged to give a π output. All the oscillator components are carried on board (10). Tuning is by permeability variation of L1 which is in series with the trimmer inductor, L2. The varactor assembly, for frequency shift and modulation, is in series with L1 and L2; L3 provides a d. c. return path for the collector of VT1. The input capacitance of the π circuit is provided by C4, C5 and C6 with the emitter of VT1 connected between C5 and C6 in the usual Colpitts arrangement; the output capacitance is provided by C10. C11 and L6 provide a high-pass filter to remove modulating frequency components from the output.

MR1 and TH1/TH2 are the clamping diode and level control thermistors with similar functions to the corresponding components in the other oscillators.

3.3 AUTOMATIC LEVEL CONTROL AND AMPLITUDE MODULATION

Every oscillator unit contains in the output circuit two thermistors arranged as an L pad. Level control is performed by a direct current bias through the thermistors; as the resistance of the series thermistor increases the resistance of the parallel one decreases giving greater attenuation whilst maintaining a constant overall impedance.

The r. f. output from each oscillator is taken to unit (29) and the oscillator in use is selected by 29SA, a switch section that is integrated into sections of 50 Ω stripline. A bridge detector incorporating MR1 and MR2 monitors the output level and displays it on the CARRIER LEVEL meter 38M1. The detector circuit is arranged to have a response rising at a rate of about 0.3 dB per 100 MHz to compensate for the insertion loss of the attenuators.

Automatic level control and amplitude modulation are carried out on board (6). The balanced output from the detector is applied also to a differential amplifier consisting of VT4 and VT5 arranged as a long-tailed pair. A second stage of differential amplification provides the current drive for the thermistors. Four transistors are used, VT6 and

VT7 arranged as a composite transistor (Darlington circuit) in one limb of a long-tailed pair with VT8 and VT9 in the other limb.

A reference voltage, determined by the setting of the CARRIER LEVEL control, 38RV7, is developed across R14 and is compared with the voltage from the detector. The system behaves as a negative feedback amplifier that acts to make the difference between these voltages zero. The amplifier has positive feedback applied across RV3 and R13 to increase the gain and so improve the effectiveness of the control system.

Also on board (6) is a clipping amplifier that squares an input waveform for use as an amplitude modulating signal. External modulating signals are fed via 38SC2B and 38SE1F or internal signals from the modulation oscillator are fed via 38R20 to VT1 and VT2. The clipped waveform is applied to the clamping diode of the r. f. oscillator in use, turning it on and off and thus producing what is effectively 100% square wave amplitude modulation. To prevent the automatic level control circuit from trying to follow the modulation, the audio frequency square wave is also applied to a gating transistor, VT3; this ensures that when the r. f. oscillator is turned off by the modulating signal the reference voltage is made zero.

Provision is made for monitoring the frequency by either an external counter or an internal crystal calibrator. Unit (29) contains an amplifier consisting of VT1 and VT2 to provide isolation and to increase the level of the signal. VT1 is a common emitter stage which is in series with a common base stage from which the output is fed to 29SB to be passed either to the crystal calibrator or to the COUNTER OUTPUT socket.

3.4 MODULATION OSCILLATOR AND DRIVE CIRCUITS

Circuit diagram—Fig. 7.8

Internal modulating signals from 20 Hz to 125 kHz are provided by a Wien bridge oscillator with eight switched frequency ranges.

Boards (4) and (8) carry the series and shunt Wien bridge capacitors respectively which are selected by 38SC2F and 38SC1F. The resistive arms of the bridge are provided principally by the ganged potentiometers 38RV4A and 38RV4B, the INTERNAL MODULATION FREQUENCY control.

The sustaining amplifier and amplitude stabilization components are carried on board (5).

VT1 and VT2 are arranged in a high gain composite transistor (Darlington) circuit. This first stage is followed by VT4 acting as a conventional amplifier and by VT5 which is connected as an emitter follower to provide a low impedance output for driving the bridge. Positive feedback is taken from C6 to the base of VT1 at a frequency that is determined by the Wien bridge.

Negative feedback from the emitter of VT5 is fed via R9 and RV2 to the emitter of VT2. The amount of feedback depends on the impedance of the network R8 shunted by the diodes MR2 and MR3. The output signal from the oscillator is fed to the peak detector, VT3, which charges C3 to a potential proportional to the peak amplitude of the output signal. This potential controls the forward bias applied to MR3 and MR2, thus if the output signal increases, the impedance of the diodes increases, thereby increasing the feedback and maintaining the output level constant. The effective value of C3 is increased by shunting it by C5 on the four lower frequency ranges.

The oscillator output voltage is related to the base emitter voltage of VT3; the emitter potential is held by the Zener diode, MR4, and the base potential is governed by the bias conditions of the amplifier as determined by the base potential of VT1. Normally, the oscillator output amplitude is set by RV1; then the SET DEVIATION control, 38RV5, acts as a potential divider controlling the amount of the output signal fed to the f. m. drive circuits. However, when the CARRIER mode switch is set to OFF, 38RV5 forms a potentiometer with R2 and R3 to control the base bias of VT1.

3.5 FREQUENCY MODULATION AND FREQUENCY SHIFT

Circuit diagram—Fig. 7.10

Each r. f. oscillator has a varactor diode across its tuned circuit whose capacitive reactance is controlled by the applied voltage. This diode is used to produce both frequency modulation and calibrated frequency shift. Most of the circuitry driving the diode is also common to both functions.

Modulating signals from the modulation oscillator are fed via 38SE1F and external signals via 38SC2B and 38SE1F to 38SE1B and thence to the SET DEVIATION control 38RV5.

Board (2) carries the drive circuitry. External frequency shift signals are fed to the input to the f. m. amplifier, VT1 and VT2, along with the modulating signals. From this point the system is direct coupled throughout. The f. m. amplifier

produces a drive signal of up to 10 V p-p about a quiescent potential of -10 V and its output impedance is established by RV8 and R5 at 5 k Ω to match the f. m. range attenuators.

D. C. signals are generated by the ΔF control supply which produces a voltage that can be set between -5 V and -15 V. VT6 operates as a constant current source developing a potential across the ΔF control, 38RV1. The value of the constant current is determined by the setting of RV5 and hence the maximum potential that can appear across 38RV1, corresponding to -5 V output. The -15 V output value, at the other extreme setting position of 38RV1 is set by RV6. The output impedance is defined by RV6, R17, 38RV1, RV7, R18 and R22, partially shunted by R21 and is brought to 5 k Ω by adjustment of RV7 to match the ΔF range attenuators.

Bias for VT1 in the f. m. amplifier is derived from the emitter of VT5 and to prevent the a. f. signal appearing on the frequency shift signal, the collector of VT5 is returned to the junction of RV5 and R16. In phase a. f. signals thereby appear at the base and emitter of VT6 and so cancel.

The outputs from the ΔF range and f. m. range attenuators are combined at 38RV3 which is used to set the sensitivity of the combined channel, against the crystal calibrator or an external counter, using a frequency shift signal. The sensitivity thus set, holds also for frequency modulation.

VT3, VT4 and VT7 produce a -10 V supply to which the f. m. range and ΔF range attenuators, as well as other circuits, are returned. The circuit amounts to a stabilizer which compares the base potentials of VT3 and VT4 and applies an error signal to VT7. Positive feedback across RV3 increases the magnitude of control and ensures that a low output impedance is achieved.

With any frequency modulator the sensitivity has to be adjusted, as the carrier frequency is altered, by a tracking system. This function is performed by a tracking network consisting of a potentiometer coupled to the oscillator tuning drive. The arrangement is shown diagrammatically in Fig. 7.10 and in detail on each of the oscillator circuits Figs. 7.1 to 7.5. Each potentiometer is tapped at sixteen points and each point is connected to one of sixteen taps on a resistive potential divider across which the modulating signal is

applied. Thus correct sensitivity can be obtained throughout the tuning range of each oscillator.

The varactor diode does not have a linear bias/reactance characteristic and, to compensate, the drive signal is pre-distorted in the reactor linearizer circuit carried on board (3). From the tracking network the signal is fed to the long tailed pair, VT1 and VT2, and thence to VT5. From VT5 the signal follows two paths; firstly, to the phase splitter, VT4, which gives a balanced output to the varactor, secondly, to VT3 which has a resistor-diode network, MR1 to MR13, R9 to R21 and R24 to R36 shunting the emitter load, R46. From VT3 a distorted version of the signal is fed to the distortion potentiometer on the r. f. unit in use and a proportion is returned to VT6 and thence to the base of VT2. Thus the distortion is introduced to the balanced signal that is fed to the varactor diode and the amount of distortion is determined by the setting of the distortion potentiometer on each r. f. oscillator unit. On most ranges this potentiometer is a simple preset control but for the 10 - 90 MHz range a network similar to the tracking potentiometer, and ganged to the oscillator tuning drive, is used to meet differing needs over the wide frequency range.

The frequency modulating signal is monitored after the f. m. amplifier by a metering circuit carried on board (7). MR4 and MR5 form a peak-to-peak detector whose output is fed to an emitter follower, VT7, and thence to the meter 38M2. For accurate monitoring at low frequencies the detector discharge time constant, determined by C10 and the input resistance of VT7, must be long; a condition which would give sluggish meter response when the modulation level is reduced. VT5 and VT6 act to reduce the discharge time constant under these conditions. If the mean signal falls, the emitter voltage of VT7 falls and a pulse differentiated by C11 and R17 turns on VT6 and VT5, placing a lower discharge impedance across C10.

3.6 CRYSTAL CALIBRATOR

Circuit diagram—Fig. 7.11

A crystal controlled 10 MHz oscillator is used as the standard to produce a series of harmonics and sub-harmonics which can be compared with an unknown radio frequency.

The 10 MHz signal follows two paths: firstly to a squaring circuit and then to two cascaded divide by ten circuits that give a train of 1 MHz and 100 kHz pulses, secondly to an amplifier and then a harmonic generator. The output from the harmonic generator is mixed with a signal from

For Service Manuals Contact
MAURITRON TECHNICAL SERVICES
8 Cherry Tree Rd, Chinnor
Oxon OX9 4QY
Tel: 01844-351694 Fax: 01844-352554
Email: enquiries@mauritron.co.uk

the r. f. oscillator and the beat frequency so produced is amplified to a controlled level before being mixed with the 1 MHz and 100 kHz pulses.

From the second mixer the beat frequency output is amplified and converted by a Schmitt trigger circuit to constant amplitude pulses. These are applied to a diode pump frequency meter whose purpose is to indicate zero beat. An alternative beat frequency output is provided to operate headphones.

Standard frequencies from 10 MHz to 100 kHz are generated on board (33). The crystal oscillator VT1, uses an oven stabilized 10 MHz crystal in a modified Colpitts circuit. Trimmer capacitor, C2, brings the frequency exactly to 10 MHz. Output is taken via a π filter circuit whose frequency is adjusted to 10 MHz by C8. VT2 is a common base class C amplifier producing a high level 10 MHz signal which is clipped by the limiter, MR1 and MR2, to give a faster rise time.

When the CRYSTAL CAL switch is in the 1 MHz position the 1 MHz storage counter operates. VT4 and VT5 are held biased non-conducting by R9 and R10. A positive going pulse edge charges C15 and C16 and the voltage developed across MR3 holds VT3 off. The negative going pulse edge turns on VT3 allowing C15 to discharge, but there is no discharge path for C16 which thereby charges up in a series of steps as successive pulses arrive. The value of C15 is set to give voltage steps such that when ten have been received the potential across C16 is just sufficient to turn on VT4. A cumulative switching action through the regenerative coupling between VT4 and VT5 occurs, both transistors are rapidly turned on and C16 is discharged. When C16 is discharged a similar switching action turns both transistors off again. The counter produces an output pulse for every ten input pulses and so, for a 10 MHz input, gives a 1 MHz pulse train output.

The 100 kHz storage counter functions in an exactly similar manner with C21 being charged in steps through C17 and MR5 and being discharged every tenth step through VT7 and VT8.

Output is also taken from the 10 MHz oscillator via VT9 acting as a common emitter, class C, tuned amplifier, to provide the drive for the harmonic generator.

The harmonic generator, mixer and amplifier stages are carried on board (34). MR1 is a step recovery diode, a device that conducts when forward biased and, because of charge storage, for part of the time when reverse biased and then abruptly cuts off. The effect, with a sinusoidal input, is to give conduction for about three quarters of a cycle followed by a step in the waveform that generates a harmonic train extending up to 1000 MHz.

T1 presents a balanced signal to T2 which in conjunction with MR2 and MR3 mixes the harmonics with the input from the r. f. oscillator. C3, L1 and C4 form a low-pass filter cutting off at 5 MHz so that only the lower beat frequency is passed to the amplifier. R3, R4 and R6 form a 21 dB attenuator to provide isolation from the r. f. oscillator. Transformers T1 and T2 amount to sections of transmission line terminated in their characteristic impedance. This arrangement gives a response maintained up to the frequency limits of the instrument. T1 uses coaxial transmission line threaded through tubes of ferrite, while the conductors of T2 are printed on both sides of the circuit board. The transformers are shown in transmission line form in Fig. 3.3.

Three stages of amplification, VT1 to VT6, each consisting of two transistors with local feedback, are cascaded. The third stage has its gain controlled by varying the impedance of MR4 which effectively shunts the emitter resistor of VT5. VT8 is biased off and does not conduct until its input exceeds about 0.25 V and then its mean current increases as the peak signal amplitude increases, i. e. as the angle of conduction increases. VT7 is direct coupled to VT8 and so the current through MR4 and hence its impedance depend on the amplifier output level which is thereby controlled.

VT10 provides muting in the absence of a signal from the amplifier by clamping the a. g. c. at minimum gain.

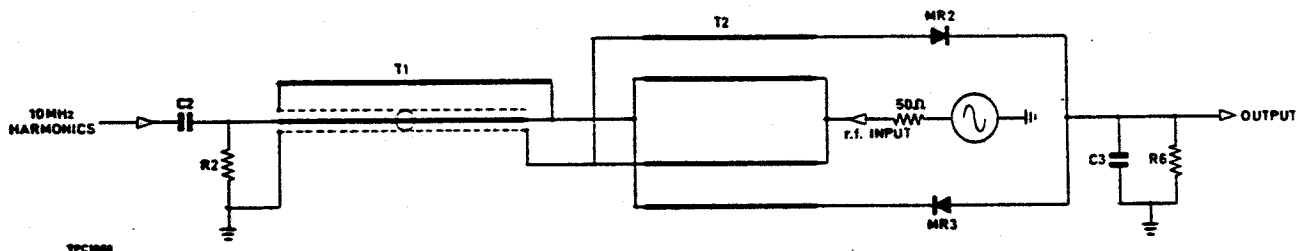

Fig. 3.3. Balanced mixer with transformers shown in transmission line form

VT9 operates as a linear amplifier when the CRYSTAL CAL switch is set to 10 MHz and as a mixer when the switch is set to 1 MHz or 100 kHz. Switching is done by forward biasing MR6 or both MR6 and MR7.

Output from the mixer is fed via the filters contained in units (35) and (36) to the crystal calibrator metering circuit carried on board (7). The bandwidth of the filters is limited to 50 kHz. VT1 and VT2 form an amplifier with local feedback whose output is fed to a Schmitt trigger, VT3 and VT4. The triggering level is set such that only the wanted beat frequency signals operate the circuit; other, spurious, signals have lower amplitudes. The output from the Schmitt trigger thus consists of a constant amplitude square wave at the frequency of the beat signal.

MR1 and MR2 together with C7 and C6 form a diode pump integrator which gives a d.c. output proportional to its input frequency and enables the meter, 38M2, to respond to the beat frequency and, particularly, to indicate zero beat.

An alternative beat frequency output from VT2 is fed via the CAL OUTPUT LEVEL control, 38RV6, to the CRYSTAL CAL OUTPUT socket, 41JKA.

The other components carried on board (7), associated with VT5, VT6 and VT7, are part of the f.m. monitoring circuit, shown in Fig. 7.10 and described in Sect. 3.5.

3.7 POWER SUPPLY

Circuit diagram—Fig. 7.14

Power supply circuits - carried on board (1) and on the lower rear panel, unit (37) - provide a stabilized 20 V supply from a.c. or d.c. inputs. The a.c. input is fed to 37T1 whose primary windings can be arranged in series or parallel for supply voltages in the ranges 190 - 260 V or 95 - 130 V respectively. Rectification is carried out by the bridge MR1 - MR4. If a d.c. input is used it is fed via 37MR1, to give protection from incorrect polarity, and selected by 37SC.

37VT1 is the series control transistor and Zener diodes MR7 and MR8 provide a reference voltage for comparison with the base voltage of VT2. Error signals from VT2 are passed to emitter follower VT1 whose output controls 37VT1.

A four wire system is used; two carry the current and two sample the voltage near to the point of use. This arrangements allows the stabi-

lizer to respond to voltage changes due to impedance of the supply line and gives better stability to the oscillators. R8 and R9 are fitted to retain operation of the stabilizer if the load is totally disconnected; for normal operation they are effectively short-circuited.

An a.c. supply for the crystal oven heater is taken from the secondary of 37VT1 through 37R2 acting as a dropper resistor. If a d.c. supply is used, the oven heater supply can be disconnected, to save current, by 37SC.

3.8 ATTENUATORS

Circuit diagram—Fig. 7.15

Two stepped attenuators are fitted to the instrument, a coarse attenuator, unit (30), giving up to 100 dB loss in 20 dB steps and a fine attenuator, unit (31), giving up to 20 dB loss in 1 dB steps.

Both attenuators are of similar construction and operation. The pad sections consist of resistive π networks with a characteristic impedance of 50 Ω .

Electrical shielding is provided in each attenuator unit by a metal casting divided into compartments which house the pads. The dimensions of the casting, together with the pads, bypass links and microswitches have been designed to maintain the characteristic impedance. Provisions are made by controlling the spacing of the components and adjustment of stray reactance, to ensure the maintenance of performance up to 1000 MHz.

Pads are brought into circuit by microswitches housed inside the screened compartments and operated, in pairs, by leaf springs which are themselves actuated by cams on the control spindles.

3.9 MECHANICAL DESCRIPTION

Structurally the instrument consists of four massive castings, the oscillator units, which are rigidly bolted together. Surrounding the castings and deriving rigidity from them, is a lighter framework consisting of two side panels with five cross members which carries the remainder of the circuitry.

The presence of four oscillator castings is essential to the strength of the instrument and versions supplied with only three r.f. ranges have a dummy oscillator unit fitted to complete the mechanical structure. Wire mesh mats are fitted between each unit to preserve r.f. earth continuity.

For Service Manuals Contact
MAURITRON TECHNICAL SERVICES
8 Cherry Tree Rd, Chinnor
Oxon OX9 4QY
Tel: 01844-351654 Fax: 01844-352554
Email: enquiries@mauritron.co.uk

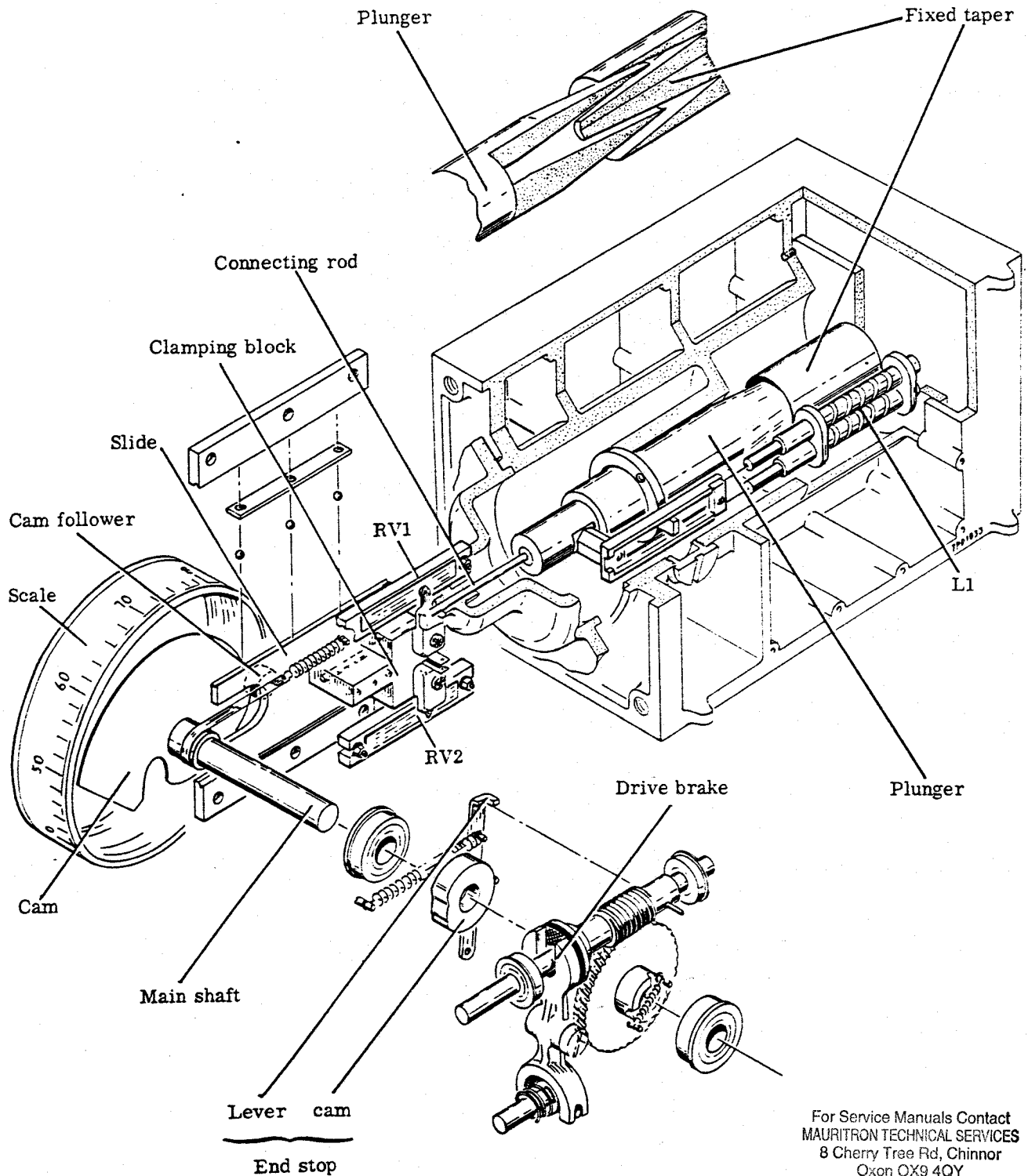

For Service Manuals Contact
 MAURITRON TECHNICAL SERVICES
 8 Cherry Tree Rd, Chinnor
 Oxon OX9 4QY
 Tel:- 01844-351694 Fax:- 01844-352554
 Email:- enquiries@mauritron.co.uk

Fig. 3.4 Exploded view of 10-90 MHz oscillator with front section of casting omitted

Each casting is made in two parts; the rear section houses the r.f. circuits and is divided into compartments with bolted on lids, the front section houses the mechanical drive and the tracking networks. Wire mesh gaskets under the rear compartment lids ensure minimum r.f. leakage.

Drive is transmitted from the tuning control knob via a worm wheel and worm to the main shaft carrying the scale drum. To improve scale linearity a stainless steel cam is driven by the main shaft. The cam follower is connected to a brass slide and is held together against the cam by

an extension spring anchored to the main shaft by way of a stainless steel tape. A Perspex clamping block mounted on the slide holds the ceramic connecting rod that finally transmits the movement to moving parts of the tuning system. The clamping block also carries the wiper of the tracking potentiometer (both wipers for the 10 - 90 MHz range).

The end stop mechanism consists of a moulded cam carried by the main shaft and which allows a lever to oppose a pin on the worm shaft at each end of the tuning range. A drive brake is fitted to operate on the worm shaft and consists of a lever that can be clamped against a disk of friction material.

A large part of the circuitry is carried on printed boards. To control the effects of stray

reactances, connections between the boards and the associated switches are made by means of printed track on double sided mother boards. The top mother board carries boards ①, ②, ④, ⑤, ⑦ and ⑧ plugged into edge connectors and provides the interconnection between them and the upper front panel controls and switches. The bottom mother board carries board ③ as well as the R. F. RANGE switch, 40SA, and provides the various supplies and inputs for the r. f. oscillators and the crystal calibrator via flexible tapes. Two similar flexible tapes run in channels in the instrument side frames to make connection between the two mother boards.

All internal connections carrying r. f. signals are made by coaxial cable with solid outer conductors to minimize leakage fields.

For Service Manuals Contact
MAURITRON TECHNICAL SERVICES
8 Cherry Tree Rd, Chinnor
Oxon OX9 4QY
Tel:- 01844-351684 Fax:- 01844-352554
Email:- enquiries@mauritron.co.uk

4.1 INTRODUCTION

This chapter contains information for keeping the equipment in good working order and for checking its overall performance.

Before attempting any maintenance on the signal generator you are advised to read the preceding technical description chapter, particularly the explanation of the system of circuit references given at the beginning.

CAUTION

This instrument uses semiconductor devices which, although having inherent long term reliability and mechanical ruggedness, are susceptible to damage by overloading, reversed polarity and excessive heat or radiation. Avoid hazards such as reversal of batteries, prolonged soldering, strong r.f. fields or other forms of radiation, use of insulation testers or accidentally applied short circuits. Even the leakage current from an unearthed soldering iron could cause trouble. Before shorting or breaking any circuit refer to the circuit diagrams in Chap. 7 to establish the effect on bias arrangements of the transistor.

Screw fasteners

Where cruciform headed screws are used, they are of the Pozidriv pattern; to avoid damaging them a Pozidriv screwdriver should be used.

4.2 REMOVAL OF CASE

1. Stand the instrument on its face.
2. Remove the six coin-slotted screws at the rear and pull off the back panel.
3. Remove the two Pozidriv screws at the front of the case.
4. Lift the case by pulling it upwards.

4.3 OVERALL PERFORMANCE TESTS

4.3.1 Test apparatus

- (a) Counter, **mi** TF 2401A plus range unit TM 7557A or TM 8267.
- (b) 50-600 MHz Converter, **mi** TM 8334.
- (c) 0.3-2.5 GHz Converter, **mi** TM 8094/1.
- (d) 50 Ω Load, **mi** TM 7967.
- (e) R. F. Electronic Millivoltmeter, **mi** TF 2603.
- (f) Coaxial 'T' Connector, **mi** TM 7948.
- (g) Power Meter, **mi** -Sanders 6598.
- (h) Thermistor Mount for (g).
- (i) Modulation Meter, **mi** TF 2300.
- (j) Wave Analyser, **mi** TF 2330.
- (k) Crystal Detector, Hewlett Packard 420A.
- (l) Sensitive Valve Voltmeter, **mi** TF 2600.
- (m) 600 Ω $\pm 1\%$ resistor.
- (n) R-C Oscillator, **mi** TF 1101.

4.3.2 Frequency

Test apparatus: a, b, c.

Connect the counter and converter to the COUNTER OUTPUT socket and turn the Signal Monitor Director to EXT. COUNTER. At frequencies below 50 MHz use the counter without the converter; between 50 MHz and 500 MHz use converter TM 8334; above 500 MHz use converter TM 8094/1.

- (i) Frequency cover

Switch, in turn, to each r.f. range; turn the Frequency control from one end of its travel to the other and check that the frequency cover is at least the nominal cover for the range.

(ii) Calibration accuracy

On each r. f. range with the tuning drive at its low frequency end stop, set the broken yellow line on the scale against the cursor.

Tune to each of the numbered calibration points on the scale and measure the frequency. The frequency error must not exceed $\pm \frac{1}{2}$ a scale division, see data summary Sect. 1.2.

(iii) Load reaction and attenuator reaction

Additional test apparatus: d.

Carry out both these tests at the upper and lower scale limits of each r. f. range.

Turn the fine attenuator to the zero attenuation position, fully clockwise, and the coarse attenuator to give 20 dB attenuation, the 60 dB above 1 μ V position. Observe the frequency with and without the 50 Ω load connected to the r. f. output socket. The difference between these two must not exceed 1 kHz.

Connect the 50 Ω load to the r. f. output socket. Turn the fine attenuator to the zero attenuation position, fully clockwise, and the coarse attenuator to give 20 dB attenuation, the 60 dB above 1 μ V position. Note the frequency. Turn both attenuator controls fully counter clockwise and note the frequency again. The difference between the two readings must not exceed 500 Hz.

(iv) Fine tuning accuracy

Make this check at the upper and lower scale limits of each r. f. range.

Turn the ΔF RANGE selector to 4 and standardize the fine tuning at positive full scale of the ΔF control by the method described in Sect. 2.4. On the 215-500 MHz and 440-1000 MHz ranges, full scale corresponds to 300 kHz and on the other r. f. ranges to 100 kHz.

Measure the frequency shift that is produced when the ΔF control is turned from 0 to positive half scale (150 kHz or 50 kHz). The error must not exceed $\pm 2\%$ of full scale (6 kHz or 2 kHz).

Set the ΔF RANGE selector to 3 and 2, in turn, and measure the frequency shift that is produced when the ΔF control is turned to positive full scale. The error must not exceed ± 1.5 kHz on a range whose full scale shift is 30 kHz or ± 1 kHz when full scale shift is 10 kHz.

Repeat the tests with negative frequency shifts after standardizing at negative full scale on ΔF RANGE 4.

4.3.3 R.F. output

Test apparatus: d, e, f, g, h.

(i) Level accuracy

Between 10 MHz and 1000 MHz use the power meter to check the output level, making the test at 5 points on the 10-90 MHz range, 8 points on the 88-220 MHz range and 12 points on the 215-500 MHz and 440-1000 MHz ranges.

Between 4 MHz and 10 MHz use the voltmeter TF 2603 with the T connector to measure the level across the 50 Ω load at 4 points in the range.

Turn both attenuators to maximum output (fully clockwise) and bring the CARRIER LEVEL meter to the SET mark with the CARRIER LEVEL control.

The output level must be 100 mV ± 1 dB up to 500 MHz and 100 mV ± 2 dB up to 1000 MHz.

(ii) Attenuators

To test the attenuators thoroughly requires specialized apparatus and methods and you are recommended to return the equipment to our Service Division if such work is required.

However, attenuator accuracy can be checked using a slide back method, where comparison is made with a standardized attenuator such as m1 TF 2163, using a sensitive receiver as indicator. To cover the full range of the coarse attenuator the receiver needs a sensitivity of 1 μ V and great care must be taken with the screening of connections.

(iii) Automatic level control

Connect the 50 Ω load to the R. F. OUTPUT socket. Tune the signal generator through each r. f. range and check that the CARRIER LEVEL meter indication remains substantially constant without alteration of the CARRIER LEVEL control.

(iv) Counter output

Use the voltmeter TF 2603 with the T connector to measure the level developed at the COUNTER OUTPUT socket across the 50 Ω load. The Signal Monitor Director must be turned to EXT COUNTER.

Tune the Signal Generator through each r. f. range and check that the level does not fall below 100 mV up to 600 MHz or 50 mV up to 1000 MHz.

4.3.4 Frequency modulation

Test apparatus: i.

(i) Tracking accuracy

Turn the ΔF control to zero, the SET ZERO and SET FULL SCALE controls to mid-travel and the CARRIER Mode switch to F.M. Tune the modulation oscillator to 1 kHz. Set up the signal generator for full scale deviation with the F.M. RANGE switch at 4.

Connect the TF 2300 Modulation meter to measure the deviation of the output signal and check that it is within $\pm 12\%$ of full scale for f.m. range 4 at 10 points on each r.f. range.

(ii) Standardized deviation accuracy

Make this test at three points on each r.f. range. At each point standardize the frequency shift and deviation circuits at full scale of range 4 against the crystal calibrator. The procedure is described in Sect. 2.4 - fine tuning.

Turn the CARRIER Mode switch to F.M. and tune the modulation oscillator to 1 kHz. Set the signal generator up for full scale deviation on f.m. ranges 4, 3, 2 and 1, in turn. On each one use the TF 2300 Modulation Meter to measure both positive and negative deviation. The average of the errors of positive and negative deviation must not exceed 6%.

(iii) Modulation frequency characteristic

Make this test at two points on each r.f. range between 10 MHz and 1000 MHz. Set the signal

generator up for a modulation frequency of 1 kHz and a deviation, indicated by the TF 2300 Modulation Meter, of 100 kHz. Change the modulation frequency to 20 Hz, 500 Hz, 10 kHz, 30 kHz, 50 kHz, 100 kHz and 125 kHz, in turn, and measure both positive and negative deviation. The average of the positive and negative deviation errors at any point must not exceed 0.5 dB (6%).

(iv) F.M. Distortion

Additional test apparatus: j.

Make this test at three points on each r.f. range. Connect the modulation meter to the R.F. OUTPUT socket of the signal generator and the wave analyser to the l.f. output sockets of the modulation meter. Set the signal generator up for full scale deviation on f.m. range 4, at 100 Hz modulation frequency. Tune the modulation meter to the signal generator frequency, set its max. mod. frequency switch to 150 kHz and measure the second and third harmonic components of the demodulated signal appearing at the l.f. output sockets of the modulation meter.

Repeat the test with modulation frequencies of 1 kHz, 10 kHz and 16.5 kHz. The total harmonic distortion, calculated from the individual components, must not exceed 2% except between 4 MHz and 20 MHz or above 500 MHz carrier frequency where they may be an extra 2%.

(v) A.M. on f.m.

Additional test apparatus: k, l.

Make this test at two points on each r.f. range. Connect the detector to the signal generator R.F. OUTPUT socket and the valve voltmeter to the output from the detector.

Set the modulation oscillator frequency to 1 kHz. Turn the CARRIER Mode switch to

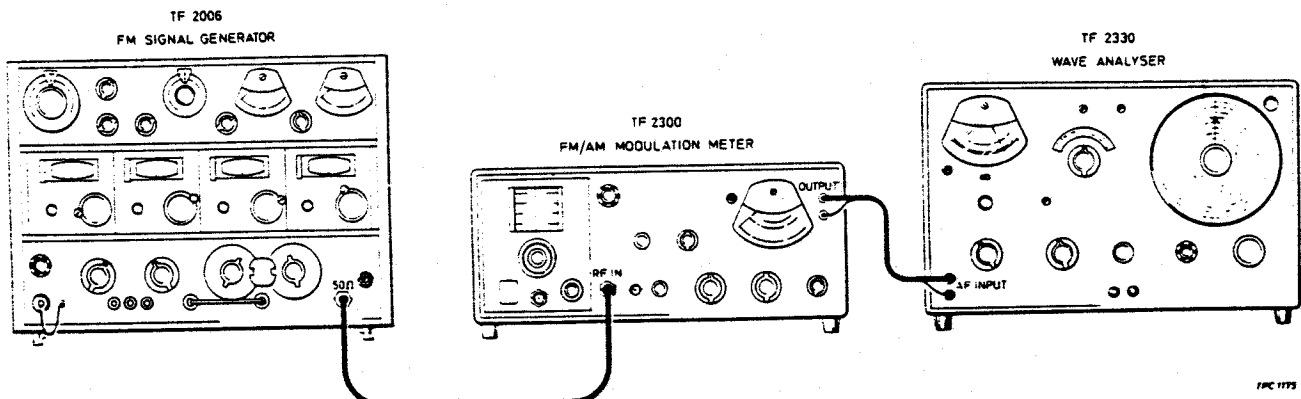

Fig. 4.1 Test apparatus arranged for distortion measurement

A.M. and note the indication (L) of the valve voltmeter. Turn the CARRIER Mode switch to F.M. and adjust the deviation to full scale on f.m. range 4 at carrier frequencies between 90 MHz and 1000 MHz and to 75 kHz at carrier frequencies below 90 MHz. Measure the spurious a.m. indicated by the valve voltmeter; this must not exceed 0.05 L between 90 MHz and 1000 MHz or 0.12 L below 90 MHz.

4.3.5 Modulation oscillator

Test apparatus: a, j, l, m.

(i) Frequency

Connect the counter to the MOD OSC OUTPUT terminals. Turn the CARRIER Mode switch to OFF. Measure the frequency at three points on each modulation frequency range. The error must not exceed 10%.

(ii) Level

Connect the 600 Ω resistor across the MOD OSC OUTPUT terminals and connect the voltmeter to read the voltage developed across the resistor. Turn the CARRIER Mode switch to OFF and adjust the SET DEVIATION control to maintain a Modulation and Calibrator Monitor reading at the 0 dBm mark. Vary the frequency from 30 Hz to 125 kHz. The voltmeter reading must remain within ± 0.5 dB of the 0 dB mark.

(iii) Distortion

Make this test at about mid-scale on each modulation frequency range.

Connect the 600 Ω resistor and the wave analyser across the MOD OSC OUTPUT terminals. Measure the second and third harmonic components of the a.f. signal and calculate the total distortion. The distortion must not exceed 1%.

4.3.6 Amplitude modulation

Make this test at two points on each r.f. range.

Adjust the MODULATION frequency controls to 1 kHz and turn the CARRIER Mode switch to A.M. Check that the CARRIER LEVEL meter indication falls to the black sector.

4.3.7 External modulation

Test apparatus: n.

(i) F.M.

Make this test at two points on each r.f. range.

Connect the a.f. oscillator to the EXT MOD sockets. Turn the CARRIER Mode switch to F.M., the F.M. RANGE switch to 4, the MODULATION selector switch to EXT and the SET DEVIATION control fully clockwise.

Tune the a.f. oscillator to 1 kHz and increase its output until the Modulation and Calibrator Monitor indicates full scale. The input level to achieve this must not exceed 1.5 V.

(ii) A.M.

Make this test at one point on each r.f. range.

Connect the a.f. oscillator to the EXT MOD sockets. Tune it to 1 kHz and set its output to 1.5 V. Turn the CARRIER Mode switch to A.M. and check that the indication of the CARRIER LEVEL meter falls to the black segment.

4.3.8 A.M. on c.w.

Test apparatus: k, l.

Make this test at two points on each r.f. range.

Connect the detector to the signal generator R.F. OUTPUT socket and the valve voltmeter to the output from the detector.

Set the modulation oscillator frequency to 1 kHz. Turn the CARRIER Mode switch to A.M. and note the indication (L) of the valve voltmeter. Turn the CARRIER Mode switch to C.W. and measure the spurious a.m. indicated by the valve voltmeter; this must not exceed 0.002 L.

4.4 CLEANING AND LUBRICATION

Rotary switches

Do not introduce any lubricant or cleaning agent to the switches of the coaxial switch assembly, unit (29).

If it is necessary to clean the contacts of any of the other rotary switches, this should be done with benzine or white spirit (not carbon tetrachloride), and the contacts should afterwards be wiped with a suitable lubricant such as a 5% solution of petroleum jelly in white spirit. Avoid lubricants containing soap or solid materials.

R.F. units

The plungers of the oscillator tuning capacitors are dry lubricated during manufacture with molybdenum disulphide powder. Under no circumstances should any other lubricant be used.

Relubrication of the r. f. drives is only likely to be required at infrequent intervals. When however it is needed a little Albaline may be applied to the slide bearings and a little molybdenum disulphide grease to the worm and worm wheel.

Attenuators

The cams and gears are lubricated during manufacture and will require no further lubrication.

4.5 MAINTENANCE ACCESSORIES

To allow tests to be made with the instrument partly dismantled, three accessories are supplied:

- (a) Coaxial extension lead with TNC connectors.
- (b) 12-way extension lead with edge connectors.
- (c) Extension board

The two extension leads enable an r. f. oscillator unit to be operated when removed from the instrument. It can be completely separate or it may still form part of the r. f. oscillator assembly.

The extension board allows any of the plug-in boards ① to ⑧ to be operated clear of the instrument. Before attempting to fit the extension board, pull out the T shaped, plastic, polarizing key that normally prevents the wrong board from being plugged into a socket. This key will be in one of the positions numbered 4, 7, 8, 9, 12, 13 or 16. The other key, which is always in position 18, must be left to ensure proper positioning of the extension board.

Each of the conductor tracks of the extension board is broken and completed with a wire link that can be removed during testing and alignment.

For Service Manuals Contact
 MAURITRON TECHNICAL SERVICES
 8 Cherry Tree Rd, Chinnor
 Oxon OX9 4QY
 Tel:- 01844-351694 Fax:- 01844-352554
 Email:- enquiries@mauritron.co.uk

5.1 INTRODUCTION

This chapter is intended to help you to fault-find, carry out internal checks, make minor adjustments and realign circuits. Use it in conjunction with the circuit diagrams in Chap. 7 and with the technical description in Chap. 3.

The complete circuit reference for a component carries its unit number as a prefix, but this prefix is usually dropped except where there is risk of ambiguity. See the explanation at the beginning of Chap. 3.

Performance limits quoted are for guidance only and should not be taken as guaranteed performance specifications unless they are also quoted in data summary, Sect. 1.2.

CAUTION

See Sect. 4.1 for precautions to be observed when handling semiconductors.

If any difficulties arise please write to or telephone our Service Division or your local Marconi Instruments agent. Our addresses and telephone numbers are given on the rear cover of this manual. In any communication quote the type and serial number of the instrument. If the instrument is being returned for repair, please indicate clearly the nature of the fault or the work you require to be done.

5.2 FAULT FINDING

5.2.1 Power supply failure—refer to Fig. 7.14

(a) Symptom - with SUPPLY switch on, CARRIER mode switch to F. M., modulation oscillator switched to any range, no reading on either CARRIER LEVEL or Modulation and Calibrator monitor:

- (i) Check fuses, if fuse blows persistently turn to symptom (b).
- (ii) Check that SUPPLY selector is in correct position.
- (iii) Check continuity across pin of mains lead.
- (iv) Remove case and check voltages to transformer.

(v) Check voltage from transformer, pins 76 and 77 of the top mother board (39). (See Fig. 7.16.)

(vi) Check unregulated rectified voltage across pins 82 and 80 of board (39).

(vii) Check unregulated voltage across pins 78 and 80 and pins 83 and 80 of board (39).

(viii) Check regulated voltage across pins 85 and 80 of board (39).

(ix) Insert extender board (see Sect. 4.5) between board (1) and top mother board (39), and check regulated and unregulated supplies on appropriate pins of the printed board. Establish if fault is a short or open circuit.

(b) Symptom - fuse blows when instrument is switched on:

(i) Check that Supply Voltage Selector is correctly set.

(ii) Connect an ohmmeter between tags 80 and 85 of top mother board (39). If a short circuit is indicated move to step (iii), if not move to step (viii).

(iii) Disconnect 40PLB from 39SKTJ. If the short circuit remains move to step (v), if not move to step (iv).

(iv) The fault lies in the crystal calibrator or the wiring to it.

(v) Disconnect 40PLA from 39SKTA. If the short remains, move to step (vii), if not move to step (vi).

(vi) Reconnect 39SKTA and 40PLA. In turn, pull off the multi-way plugs to the oscillator units, pull out the reactor linearizer board (3) and unsolder the lead to 29C17 of the coaxial switch to isolate the fault to a particular unit.

(vii) In turn, pull out boards (2), (5), (6), (7) and (1) to isolate the fault to the particular unit. If the fault remains it must be in the wiring of the top mother board (39).

(viii) With board ① removed, connect an ohmmeter between tags 80 and 82 of the top mother board ③. If a short circuit is indicated suspect 37C1 or 37C2.

(ix) If the fault has not so far been found suspect transformer 37T1 or the input circuit.

5.2.2 Operation failure, r.f.—refer to Figs. 7.1 to 7.6

(a) Symptom - no output but power supply works:

- (i) Try the output on all ranges.
- (ii) Establish if both the carrier level meter reading is zero and output from output socket is zero.

(b) Symptom - no output from one range only:

- (i) Try the range in another position in the instrument, using extender leads provided.
- (ii) If correct on other positions, check the r. f. cable.
- (iii) Check the input socket and switch wafers for that range.
- (iv) If incorrect in all positions, check series thermistor, TH2, on oscillator output filter board for open circuit.

(c) Symptom - output from generator high but carrier meter reading low and cannot be adjusted by 6RV5:

- (i) Check the monitor rectifiers, MR1 and MR2, board ②.

(d) Symptom - output high and carrier meter reading high:

- (i) If on one r. f. range only check parallel thermistor, TH1, on oscillator output filter boards for open circuit.
- (ii) If on all r. f. ranges, check feed to thermistor, TH1, and check a. l. c. board ④.

5.2.3 F.M. and ΔF failure—refer to Figs. 7.8 and 7.10

(a) Symptom - no indication on the modulation meter i. e. modulation oscillator failure:

(i) Check boards ④, ⑤ and ⑧, one or all as required.

(ii) Check 38RV5.

(iii) Check appropriate tracks on top mother board ③.

(b) Symptom - modulation meter reads, frequency shift works but no frequency modulation:

(i) Ensure Modulation Monitor and Calibrator Selector is in OFF position.

(ii) Check the f. m. part of board ②.

(iii) Check appropriate tracks on top mother board ③.

(iv) Check f. m. range attenuators.

(c) Symptom - modulation meter reads, no frequency shift and no frequency modulation:

(i) If on one r. f. range only, check on a different oscillator position (by using the extension leads supplied) and if still no modulation the fault is in the oscillator. Check tracking network, the input filters and the varactor diode.

(ii) If on all r. f. ranges, check board ②, f. m./ ΔF drive. Check reactor linearizer board ③. Check appropriate tracks on top and bottom mother boards and interconnecting tapes.

(d) Symptom - no ΔF but f. m. works.

(i) Check ΔF control supply in board ②.

(ii) Check ΔF control 38RV1 and interconnection to board ②.

(iii) Check ΔF range attenuator and interconnections.

5.2.4 Square wave amplitude modulation failure—refer to Fig. 7.6

Symptom - with CARRIER Mode switch at \square A. M. and modulation oscillator on 630 Hz - 2 kHz range, CARRIER LEVEL meter does not fall to black sector.

Check the output with a detector and oscilloscope to establish if it is squared.

(i) If the output is squared, check board ⑥ between VT2 and base of VT4.

(ii) If the output is not squared, check CARRIER Mode switch 38SE. Check VT1 and VT2 circuitry of board ⑥. Check inter-connections between modulation oscillator and board ⑥.

5.2.5 Crystal calibrator failure—refer to Figs. 7.11 and 7.6

(a) Symptom - 10 MHz markers are present, but either the 1 MHz or the 100 kHz markers or both are missing:

(i) Check supply lines F, G and H, if necessary, back through to switch 38SD2F.

(ii) Check through from VT2 to VT8 on board ③③. Component replacement may require adjustment of C15 or C17; the procedure is described in Sect. 5.3.

(b) Symptom - not functioning at all:

(i) Check that the Signal Monitor Director switch is set to INT CRYSTAL CAL.

(ii) Check whether markers can be heard correctly with headphones at the CRYSTAL CAL OUTPUT socket. If so, move to step (iii), if not move to step (iv).

(iii) On board ⑦ check the trigger circuit and the detector MR1, MR2. Check the meter 38M2 and switch 38SD1.

(iv) Using an oscilloscope as a signal tracer, follow the signal path back through the metering amplifier, the mother board inter-connections, the filters and the circuitry on amplifier and mixer board ③④.

(v) Check whether the r. f. input is present at 32SKTA. If so move to step (vi), if not move to step (vii).

(vi) Check the circuitry associated with VT1 and VT9 on standard frequency generator board ③③. Check the crystal making sure it is firmly in its socket.

(vii) Check the coaxial link between the coaxial switch and the calibrator units. In unit ②⑨ check switch 29SB and amplifier VT1 and VT2.

5.3 CIRCUIT VOLTAGES

The voltages given on the circuit diagrams are those which may be expected on a typical TF 2006, at a mains input of 240 V, using a 20 kΩ/V meter. All are negative with respect to earth.

The controls were set to the following positions:

SUPPLY	ON
R. F. RANGE	according to the range under test
CARRIER Mode boards ①, ②, ③, ⑥, ⑦	C. W.
board ⑤	F. M.
boards ③③ and ③④	OFF
CARRIER LEVEL	meter at SET
Modulation Monitor and Calibrator Selector boards ③③ and ③④	OFF
Modulation	100 kHz
SET DEVIATION board ⑤	1 kHz
SET ZERO	for meter full scale
SET FULL SCALE	mid-travel
Δ F RANGE	mid-travel
F. M. RANGE	4
Δ F	4

For Service Manuals Contact MAURITRON TECHNICAL SERVICES 8 Cherry Tree Rd, Chinnor Oxon OX9 4QY Tel: 01844-351694 Fax: 01844-352554 Email: enquiries@mauritron.co.uk

5.4 WAVEFORMS

The waveforms illustrated below were taken on a typical TF 2006 using an *mi* Oscilloscope TF 2200. Each measurement was taken between the point indicated and earth.

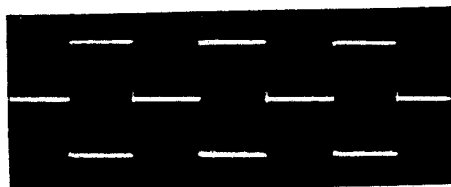

Fig. 5.1 Output waveform, carrier frequency 10 MHz, 1 kHz square wave modulation output level 88 dB above 1 μV



Fig. 5.2 As Fig. 5.1 after detection

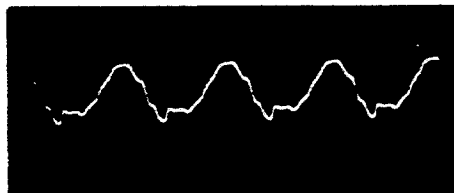

Fig. 5.4 Crystal oscillator output waveform at test point (1), board (33), 3 V p-p

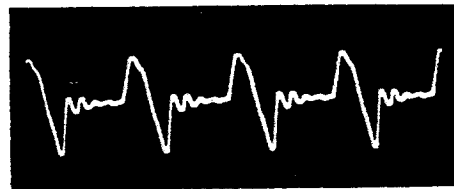

Fig. 5.6 Output waveform from harmonic generator, across 34R1, 1.5 V p-p

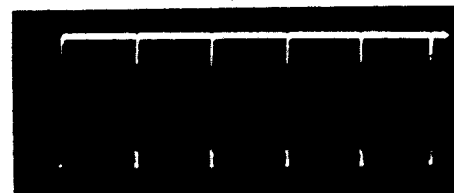

Fig. 5.8 Output waveform from 100 kHz storage counter, test point (4), board (33), 18 V p-p

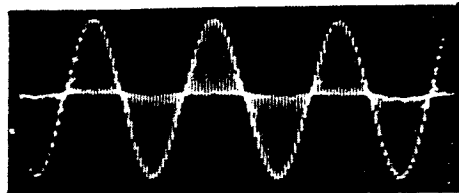

Fig. 5.3 Stereo multiplex waveform carrier frequency 90 MHz, modulating frequency 1 kHz, after demodulation by TF 2300 Modulation Meter

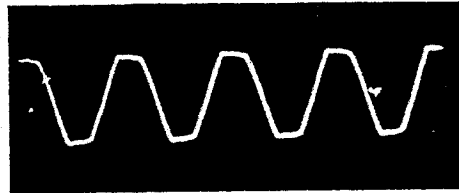

Fig. 5.5 Clipped waveform at test point (2), board (33), 4.4 V p-p

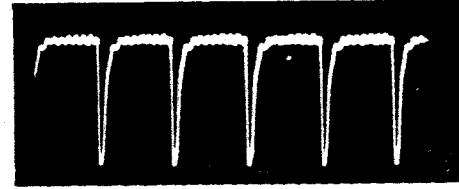

Fig. 5.7 Output waveform from 1 MHz storage counter, test point (3), board (33), 18 V p-p

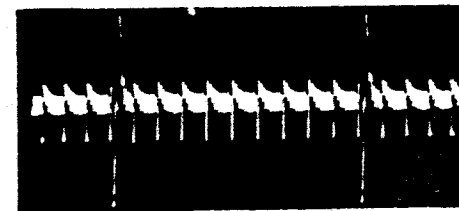

Fig. 5.9 Input waveform to mixer, base 34VT9, showing 100 kHz, 1 MHz and 10 MHz pulses

5.5 ACCESS TO COMPONENTS

Remove the case as described in Sect. 4.2.

Now accessible are boards (1), (2), (4), (5), (6), (7) and (8) all plugged into the top mother board and the components on the front panel.

To remove any of the boards (1), (2), (4), (5), (6), (7) or (8):

Remove the cross-rail by extracting the two \pm BA screws at each end. The boards can now be pulled out of their sockets in the mother board. If required, any board can be operated clear of the instrument by plugging in extension board (see Sect. 4.5) and refitting the circuit board in the socket at the end of extension board.

The TNC connectors are screwed up firmly

to minimize r.f. leakage. To disconnect them nut pliers will be needed; a suitable type is Bahco model 221 Universal Slip Joint Pliers.

R.F. units

The components on the r.f. oscillator boards (10), (13), (18), (22) and (26) are accessible without removing the r.f. unit assembly from the main chassis by simply removing the cover plate at the end of the r.f. unit in question.

Removal of r.f. unit complete

NOTE: This procedure will be found easier if the crystal calibrator unit is first removed.

1. Pull off the multi-way connectors and disconnect the TNC connector from each r.f. unit.

2. Extract the eight 2 BA screws (four on each side) that secure the r. f. unit assembly to the side frames of the instrument.
3. Remove the brackets, (one on each side) that steady the rear of the r. f. unit assembly. Each bracket is held by two 2 BA screws.
4. Slide the whole r. f. unit assembly out backwards taking care not to trap any of the connectors. The tracking networks are now accessible; so are the filter and level control circuits, after removing the appropriate cover plates.

Separating the r.f. units

On each oscillator:

1. Slacken the hexagon socket setscrews (0.050 inch across-flats key required) securing the drive lock knob and the two hexagon socket setscrews (1/16 inch across-flats key required) securing the tuning knob.
2. Pull the knobs off.
3. Withdraw the two 6 BA screws that hold the dummy front panel in place; lift it away.
4. Withdraw the two 4 BA screws that secure the front of the r. f. unit to the assembly front panel.

On the assembly:

Unscrew a bolt from one end of each of the brass tubes (a 7/16 inch Whitworth spanner is required) and slide out both tubes.

The r. f. units are now free and can be lifted apart.

NOTE: When reassembling take care that (a) the wire mesh mats are in place between the front sections of the r. f. units, (b) the outer units have fitted to them the channel section which must engage with the runners of the main chassis.

Crystal calibrator

1. Lay the instrument bottom up.
2. Pull off the multi-way connector and disconnect the TNC connector.

3. Remove the four 2 BA screws (two at the top and two at the side).
4. The calibrator unit can be lifted out. Remove the top cover for access to units (33) and (35), the bottom cover for units (32), (34) and the crystal oven. With covers removed the calibrator unit may be placed back in position and the connectors re-inserted for adjustment of the preset controls.

Coaxial switch

Removal of this unit is much easier if the r. f. unit assembly is first taken out:

1. Slacken the grub screws (1/16 inch across-flats key required) holding the R. F. RANGE and Signal Monitor Director knobs and pull off both knobs.
2. Remove the nuts that hold the switch bushes to the front panel (5/16 inch Whitworth spanner required).
3. Disconnect the seven TNC connectors.
4. Slacken the setscrews holding the flexible coupling on the r. f. range switch shaft and push it back until it clears the portion of the shaft on the coaxial switch.
5. Unsolder the wires that lead to tags on the bottom mother board.

For Service Manuals Contact
MAURITRON TECHNICAL SERVICES
8 Cherry Tree Rd, Chinnor
Oxon OX9 4QY
Tel: 01844-331694 Fax: 01844-352554
Email: enquiries@mauritron.co.uk

Attenuators

The attenuators are precision devices requiring during their manufacture specialized jigs and test apparatus. They rely for the maintenance of their high frequency performance on close electrical and mechanical limits. You are recommended, therefore, not to attempt any repair and, if the attenuators need attention, to return them to our Service Division.

To remove the attenuators from the instrument:

1. Remove the attenuator scale plate (held by two 6 BA screws).
2. Slacken the hexagon socket setscrews securing the attenuator knobs and pull them off.
3. Withdraw the eight 6 BA screws holding the attenuators to the front panel.

4. Withdraw the three 6 BA screws holding the bottom chassis cross rail to the attenuator casting, and the four 4 BA screws holding the rail to the chassis.

5. If the r. f. oscillator assembly has not been removed disconnect the 12-way connectors from the oscillator units in positions C and D and the TNC connector from the oscillator in position D.

6. Slide the attenuator assembly backwards until the type N sockets and control spindles are clear of the front panel and then lift it away from the chassis.

5.6 COMPONENT LOCATION

The following photographs indicate the location of printed boards, other sub-assemblies and components.

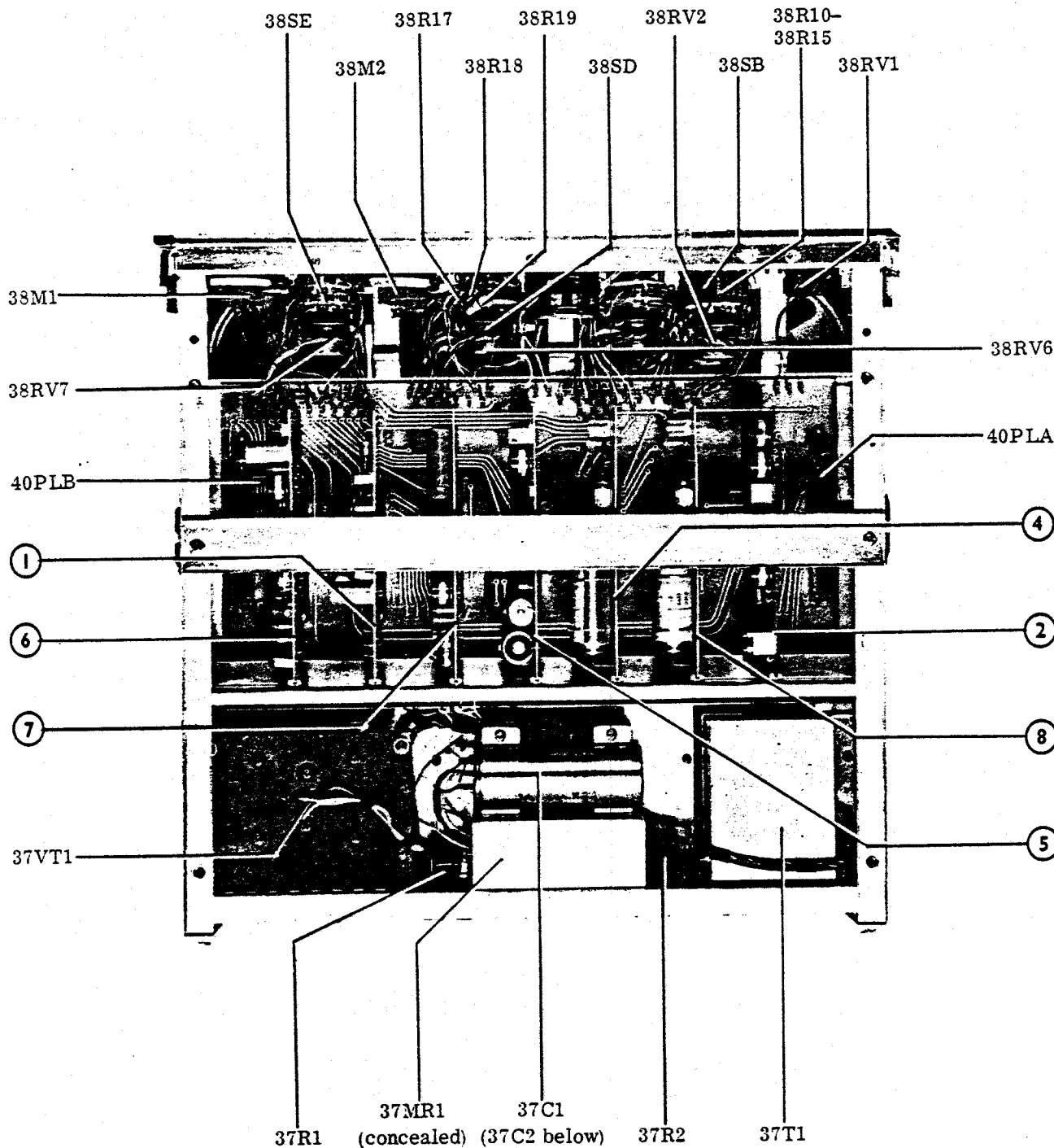

Fig. 5.10 Top view of instrument with case removed

Fig. 5.11 Bottom view of instrument with case removed

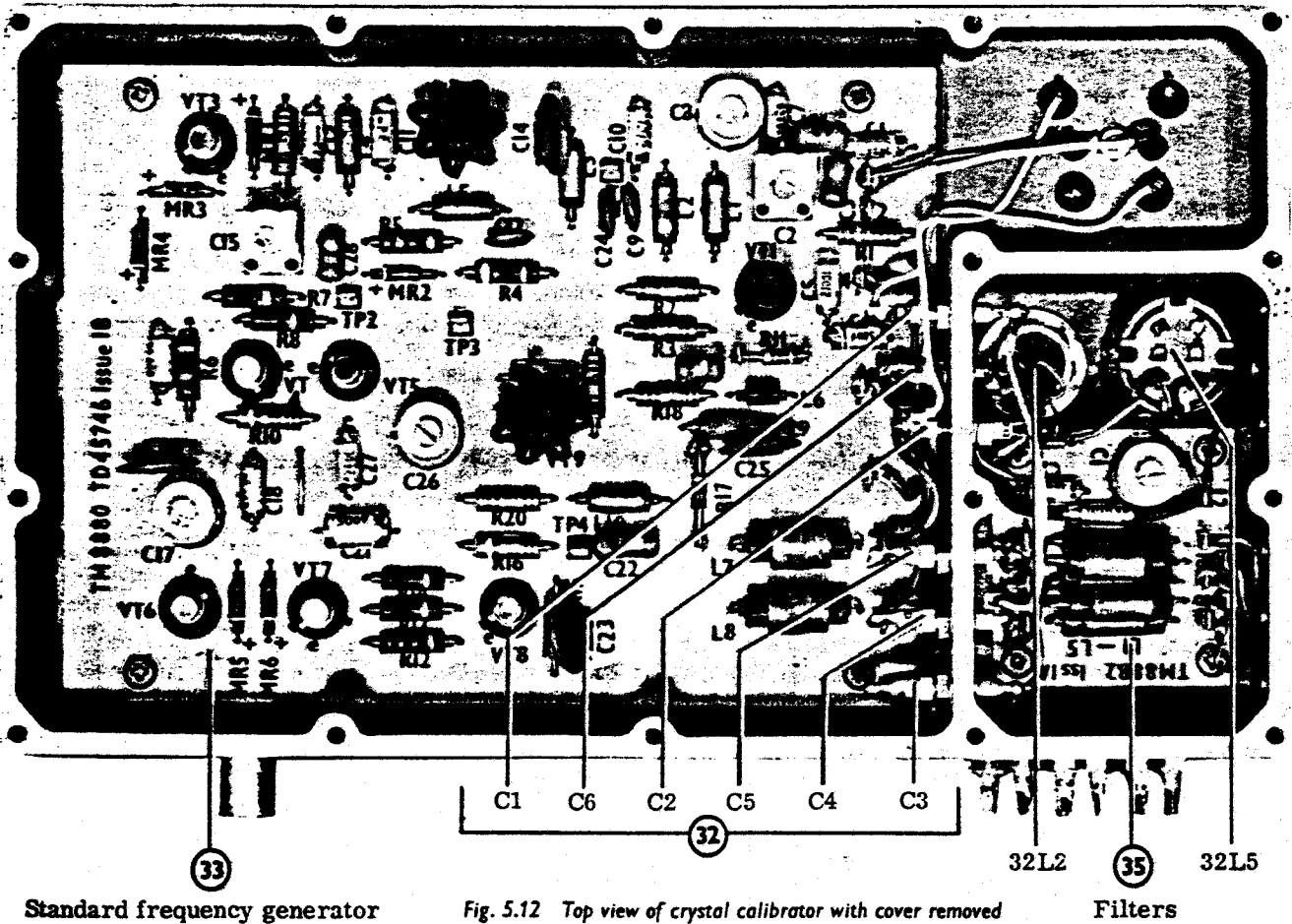
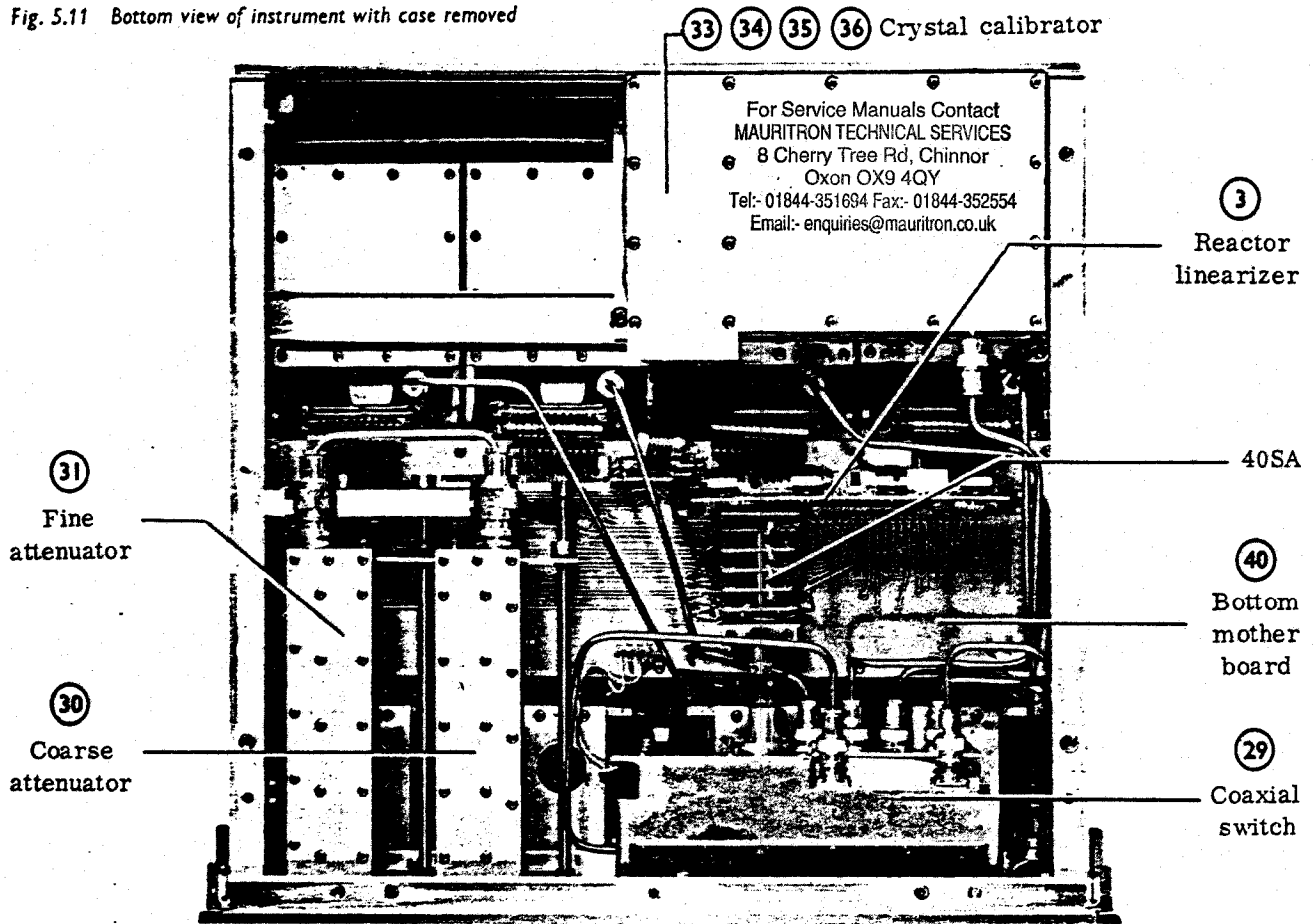

Fig. 5.12 Top view of crystal calibrator with cover removed

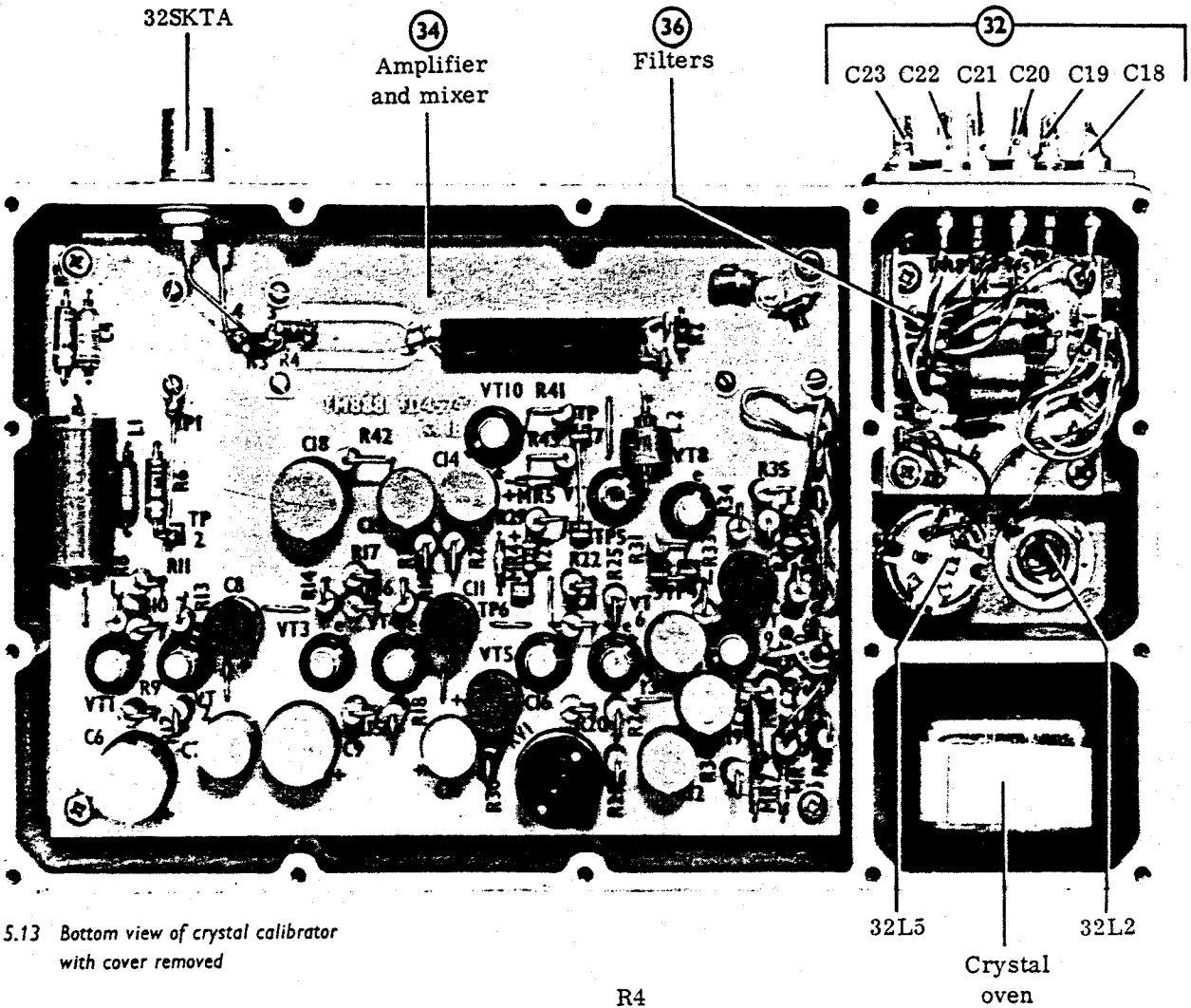

Fig. 5.13 Bottom view of crystal calibrator with cover removed

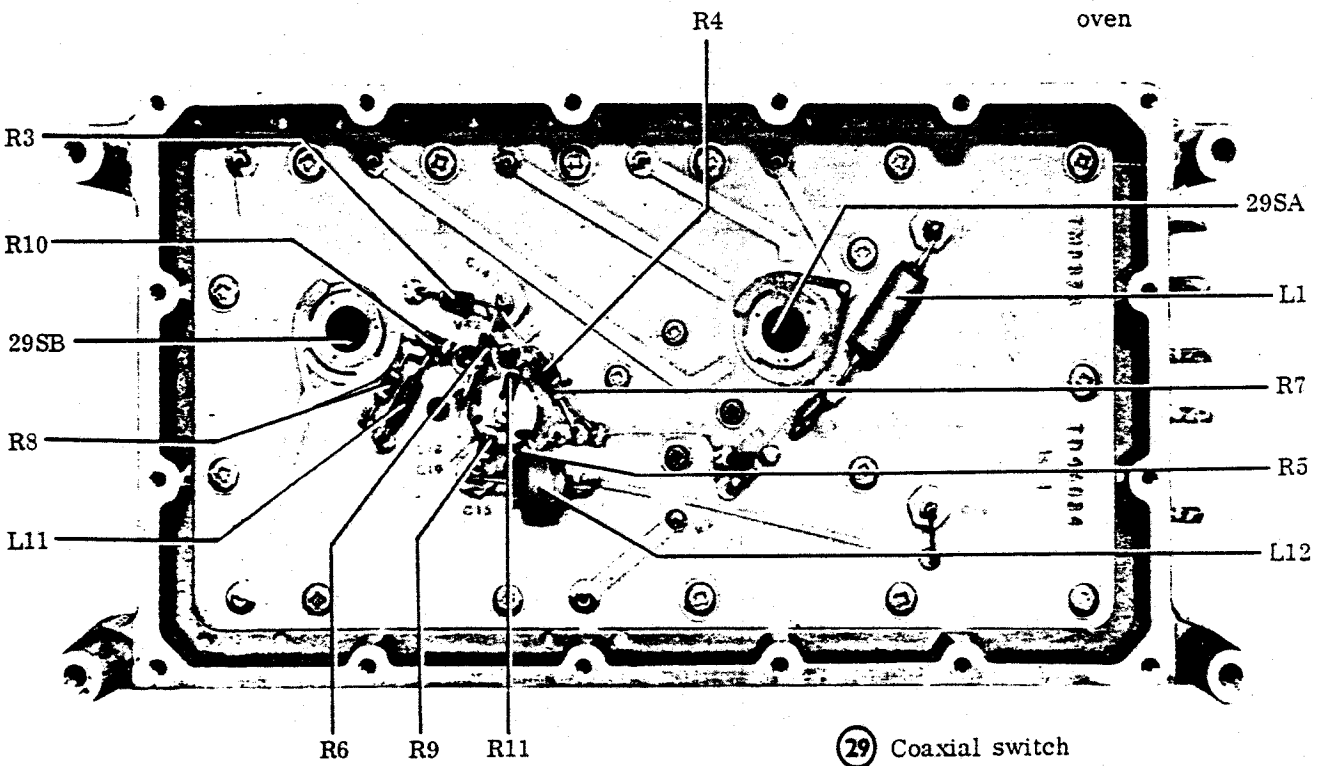

Fig. 5.14 Front view of coaxial switch with cover removed

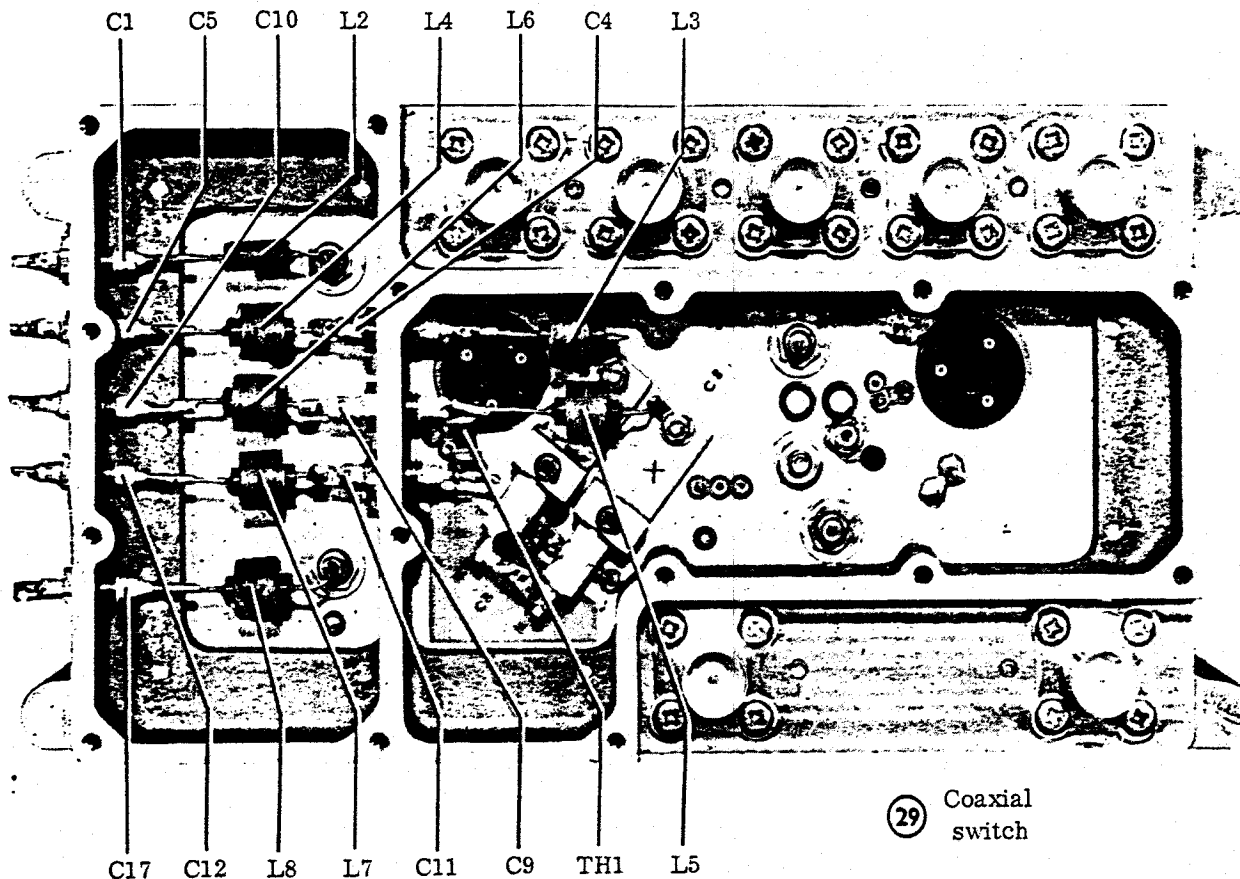

Fig. 5.15 Rear view of coaxial switch with cover removed

5.7 FUSES

Two fuses are fitted; one is fitted in the a. c. power input circuit and the other in the d. c. power input circuit. Both are accessible at the rear of the instrument without removing the case.

Both fuses are 20 x 5 mm standard cartridge types.

Table 5.1

Fuse	Rating	Type
37FS1 (230 V)	160 mA	quick-acting
(115 V)	250 mA	time lag
37FS2	1 A	quick-acting

5.8 ADJUSTMENT AND CALIBRATION

5.8.1 Test apparatus

- (a) 500 Ω potentiometer or resistance box.
- (b) 50 kΩ variable resistor or resistance box.
- (c) 200 mA load (100 Ω, 5 W resistor with series switch).

- (d) Differential Voltmeter, **mi** TF 2606.
- (e) Multimeter, e.g. Avometer model 8. Two required.
- (f) Universal Bridge, **mi** TF 1313A.
- (g) Oscilloscope, **mi** TF 2200A with TV Differential Unit, TM 6457A and two probes TM 8110 and TM 8120.
- (h) Valve Voltmeter, **mi** TF 2600 (standardized at 1 kHz for 3.54 V and 1.77 V).
- (i) Wave Analyser, **mi** TF 2330.
- (j) Counter, **mi** TF 2401A with range unit TM 7557A or TM 8267.
- (k) R-C Oscillator, **mi** TF 1101.
- (l) Distortion Factor Meter, **mi** TF 2331.
- (m) Modulation Meter, **mi** TF 2300.
- (n) 2.2 kΩ variable resistor.

5.8.2 Power supply—board ①

Test apparatus: a, b, c, d.

Remove printed boards ①, ②, ⑤, ⑥, and ⑦ from the top mother board.

Disconnect the mother boards from each other by disconnecting 39SKTA from 40PLA and 39SKTJ from 40PLB.

Refit power unit regulator board ① using the extender board (see Sect. 4.5).

Disconnect R6 and fit the 50 k Ω variable resistor in its place. Disconnect R11 and R12 and fit the 500 Ω potentiometer between tags 3 and 6 with the slider to tag 4.

Connect the differential voltmeter and the 200 mA load between contacts 16 and 17 of the extender board.

Connect the signal generator to the supply and switch on. Adjust the 500 Ω potentiometer until the differential voltmeter indicates between 19.8 and 20.0 V. Adjust the 50 k Ω resistor so that when the 200 mA load is switched on or off the change in voltage, indicated by the differential voltmeter, is less than 2 mV.

Measure the resistances in circuit and fit resistors of the nearest preferred value for R6, R11 and R12.

5.8.3 Modulation oscillator—boards ④ ⑤ ⑧

Test apparatus: e, f, g, h, i, j.

(i) Using the multimeter set the frequency dial so that it is symmetrically disposed with respect to the end ramps of 38RV4.

(ii) Connect the universal bridge between the front section wiper of 38RV4B and contact 10 of board ④. Set the frequency dial to 200 and adjust 4RV1 for the bridge to read 6740 $\Omega \pm 1\%$.

(iii) Connect the universal bridge between the rear section wiper of 38RV4A and contact 10 of board ⑧. Set the frequency dial to 200 and adjust 8RV1 for the bridge to read 6740 $\Omega \pm 1\%$.

(iv) Connect the supply and switch on. Turn the Modulation Selector to 63-125 kHz. Connect the oscilloscope to the Modulation Oscillator Output terminals and turn the CARRIER Mode switch to OFF. Adjust 5RV2 until oscillation just commences. Make sure that oscillation is maintained at all frequencies between 63 kHz and 125 kHz and readjust 5RV2 if necessary.

(v) Connect the valve voltmeter to the Modulation Oscillator Output terminals. With the SET DEVIATION control at mid-travel adjust 5RV1 until the valve voltmeter reads 1.55 V.

Connect the wave analyser to the Modulation Oscillator Output terminals. Tune the modulation oscillator to 1 kHz. Adjust 5RV3 for minimum distortion indicated by the wave analyser.

(vi) Connect the counter to the Modulation Oscillator Output terminals. Turn the Modulation Selector to 20 kHz - 63 kHz and adjust 4C8 and 8C8 for correct calibration of the MODULATION FREQUENCY scale. If necessary, new values may be selected for 4C7 and 8C7.

Turn the Modulation Selector to 63 kHz - 125 kHz and adjust 4C10 and 8C10 for correct calibration of the MODULATION FREQUENCY scale. If necessary, new values may be selected for 4C9 and 8C9.

5.8.4 F.M. and ΔF drive—board ②

Test apparatus: d, e, f, h, i, k.

(i) Remove board ② and refit using the extender board (see Sect. 4.5) to hold it clear of the others. Connect the differential voltmeter between contact 6 and contact 16 and switch the instrument on. Adjust 2RV2 for an indication of exactly -10 V on the differential voltmeter.

(ii) Modify the extender board by opening the link in series with contact 6. Connect the r.c. oscillator via a series 10 k Ω resistor to contact 6 of board ② and the wave analyser direct to the same point. Connect the earth leads of the oscillator and wave analyser to contact 16.

Switch the signal generator on and adjust the r.c. oscillator to give 20 V at 1 kHz. Tune the wave analyser to the same frequency and adjust 2RV3 for minimum indication on the wave analyser.

(iii) With the link in series with contact 6 of the extender board still open, connect the differential voltmeter between contacts 10 and 16 of board ②. Adjust 2RV1 until the voltmeter reads exactly -10 V.

Remove the link in series with contact 5 and connect the valve voltmeter between contacts 5 and 16 of board ②. Set the modulation oscillator frequency to 1 kHz. Advance the SET DEVIATION control until the valve voltmeter indicates 3.54 V exactly.

Connect a 5 k Ω resistor between contacts 5 and 6 of board ② and adjust 2RV8 until the valve voltmeter indicates 1.77 V exactly.

(iv) Restore the extender board to its unmodified state and disconnect the signal generator from the

supply. Disconnect the link between test points ② and ③. Disconnect the leads from 38RV1 and connect the bridge between its slider and one end.

Measure the change of resistance between the +10 and -10 positions of the ΔF scale. Calculate the current required to develop 10 V across this resistance.

Reconnect the leads to 38RV1 and, inserting a milliammeter in series with the wiper, reconnect the signal generator to the supply and switch on. Adjust 2RV5 until the milliammeter indicates the current previously calculated.

Reconnect the lead to the wiper of 38RV1 and connect the differential voltmeter between this point and earth. Set the ΔF scale to -10 and adjust 2RV6 for an indication of -15 V on the differential voltmeter. Set the ΔF scale to +10; the differential voltmeter should read -5 V. If it does not, readjust 2RV5 and 2RV6.

Remove the differential voltmeter and switch the signal generator off. Connect the link between test points ② and ③. With R. F. RANGE switch in position A remove the multiway plug from oscillator A. Switch ΔF RANGE and F. M. RANGE switches to position 4 and set ΔF control to -10. Connect the valve voltmeter across contacts 5 and 16. Switch signal generator on and adjust 2RV7 for 1.77 V r. m. s. Remove valve voltmeter and reconnect plug to oscillator A.

Remove the link between test points ② and ③ and switch the signal generator on. Set the ΔF control to 0, the CARRIER Mode switch to F. M. and the modulation frequency controls to 20 Hz. Turn the SET DEVIATION control fully clockwise. Connect the wave analyser, tuned to 20 Hz, between contact 2 of board ② and earth. Adjust 2RV4 for minimum indication on the wave analyser. Reconnect the link between test points ② and ③.

If a signal greater than 1 mV is indicated, a new value should be selected for 2R16. Changing the value of 2R16 requires the setting up of 2RV5 and 2RV6 to be repeated.

5.8.5 Modulation monitor—board ⑦

(i) With the signal generator switched off, check that the pointer of the Modulation and Calibrator meter is at zero. If necessary adjust the setscrew at the top of the meter to achieve this position.

Remove board ⑦ and refit using the extender board (see Sect. 4.5).

Switch the signal generator on, turn the Modu-

lation Monitor and Calibrator selector to READ F. M. and the CARRIER Mode switch to C. W. Adjust 7RV4 so that the pointer of the Modulation and Calibrator meter is at zero.

(ii) Set the modulation oscillator to 10 kHz, the Modulation Monitor and Calibrator selector to READ F. M. and the CARRIER Mode switch to F. M. Turn the ΔF control to +10.

Adjust 38RV5 (SET DEVIATION) so that the peak value of the modulating sine wave at tag 11 of the top mother board ③⑨ is equal to the frequency shift voltage at tag 10 of the top mother board ③⑨. The shift voltage is the difference between the measured voltages with the ΔF control at 0 and at +10.

In manufacture this test is made using an electro-mechanical chopper to display alternately the two voltages under comparison on an oscilloscope. Other methods of comparison can be used, e. g. two voltmeters, at the risk of the loss of some accuracy.

With the peak sine wave voltage equal to the frequency shift voltage, adjust 7RV3 until the Modulation and Calibrator meter reads 100.

5.8.6 Reactor linearizer—board ③

Test apparatus: e, g.

(i) Remove board ③ and refit using the extender board (see Sect. 4.5) modified as follows:

Connect a 2.5 k Ω resistor between contacts 8 and 11.

Connect a 10 k Ω potentiometer between contacts 5 and 6 with the slider to contact 9.

Connect a lead from contact 11 of the extender board to contact 9 of 38SKTA.

Connect two oscilloscope probes (x1), each via a 2.2 k Ω resistor to contacts 6 and 7.

Set the signal generator as follows:

Turn the R. F. RANGE switch to A and pull off the multi-way connector from the range A oscillator unit.

Set the modulation oscillator frequency to 1 kHz, the ΔF RANGE and F. M. RANGE selectors to 4, the CARRIER Mode switch to F. M., the Modulation Monitor and Calibrator selector to READ F. M. and turn the SET Full scale control to mid-range.

Connect the oscilloscope probes to the A and B inputs of TV differential unit and set the oscilloscope controls as follows:

Time base:	500 μ s
Triggering:	AUTO
Voltage scale:	x10
Voltage range:	5
Switched gain control:	x1
Variable gain control:	fully clockwise
Inputs A and B:	d. c.

Turn the signal generator on and adjust the SET DEVIATION control for full scale on the Modulation Monitor. Connect the multimeter to read voltage between contact 7 and earth.

(ii) Turn the potentiometer on the extender board to the linear position (slider to contact 7). Adjust 3RV1 so that the multimeter reads -15 V and simultaneously adjust 3RV3 for a 16 V p-p signal on the oscilloscope. Reconnect the multimeter to check that the voltage on contact 6 is -5 V.

(iii) Turn the potentiometer on the extender board to the non-linear position (slider to contact 5) and adjust 3RV4 for a 16 V p-p signal on the oscilloscope (the waveform will be highly distorted). Adjust 3RV2 until the displayed waveform is just limited and turn the control back slightly.

(iv) Repeat the adjustment of 3RV1 and 3RV3, having returned the potentiometer on the extender board to the linear position.

5.8.7 Automatic level control and amplitude modulator—board ⑥

Test apparatus: e, g.

(i) Turn the R. F. RANGE switch to A and pull off the multi-way connector from the range A oscillator unit. Remove the a. m. driver board ⑥ and refit using the extender board modified as follows:

Contact 6 open circuit.

A 4.7 k Ω resistor connector between contacts 15 and 17.

Connect the multimeters, set to read direct current, one between test point ③ and earth and the other between test point ④ and earth. Turn the CARRIER Mode switch to C.W., 6RV3 fully counter-clockwise, and RV2 and RV4 to mid-travel.

(ii) Adjust 6RV2 and 6RV4 until both multimeters read 45 mA. If the CARRIER LEVEL meter is not at its zero deflection point (extreme left-hand position), adjust 6RV2 and 6RV4 simultaneously to bring it to zero whilst maintaining the 45 mA indication on the multimeters.

(iii) Increase the feedback by turning 6RV3 clockwise, in increments, and each time repeating step (ii) until the feedback is excessive. That this point has been reached is indicated by one multimeter having a very high reading while the other reads zero. Turn 6RV3 back just sufficiently for both meters to read 45 mA again.

(iv) Turn the CARRIER Mode switch to \square A.M. and set the modulation oscillator frequency to 1 kHz. Connect the oscilloscope to contact 15 of board ⑥ and observe the squared waveform. Adjust 6RV1 to obtain a mark to space ratio of 1:1.

5.8.8 Crystal calibrator—boards ⑦ ③③ ③④

Test apparatus: e, g, k, j.

(i) Turn the Modulation Monitor and Calibrator selector to 10 MHz. Connect the oscilloscope, using the x10 attenuator probe, to test point ① on board ③③. With 33C2 at mid-setting adjust 33C8 for maximum signal on the oscilloscope.

(ii) Reconnect the oscilloscope probe to tag 3 on board ③③. Adjust 33C26 for maximum signal on the oscilloscope.

(iii) Connect the counter, using the oscilloscope x10 attenuator probe, to tag 1 on board ③④. Adjust 33C2 until the frequency is exactly 10 MHz.

NOTE: Since the presence of the cover will pull the frequency slightly, check the frequency with the top cover laid in position.

(iv) Connect the multimeter between test points ⑥ and ⑦ on board ③④ and the oscilloscope via the x10 attenuator probe to test point ③ on board ③④. Tune the signal generator to 1000 MHz, set the CARRIER Mode switch to C.W. and the Signal Monitor Director to INT CRYSTAL CAL. Adjust 33C26 for minimum reading on the multimeter. Adjust 34RV1 to give a signal of 560 mV p-p displayed on the oscilloscope.

(v) Turn the Modulation Monitor and Calibrator selector to 1 MHz. Connect the counter via the x10 attenuator probe to test point ③ on board ③③. Adjust C15 so that the frequency indicated by the counter is 1 MHz.

(vi) Turn the Modulation Monitor and Calibrator selector to 100 kHz. Connect the counter via the x10 attenuator probe to test point \diamond on board (33). Adjust C17 so that the frequency indicated by the counter is 100 kHz.

(vii) Remove the crystal calibrator metering board (7) and refit using the extender board (see Sect. 4.5). Connect the multimeter across 7R11 and adjust 7RV1 until the voltage indicated is less than 1 V. Turn RV2 to within $\frac{1}{4}$ turn of its fully counter-clockwise position.

Connect the r-c oscillator, set to deliver 20 mV at 50 kHz, to contact 15 of board (7). Adjust 7RV1 so that the indication on the Modulation and Calibrator Monitor just collapses. Increase the output from the r-c oscillator slightly, to trigger the Modulation and Calibrator Monitor and then adjust RV2 for full scale deflection.

5.8.9 R.F. oscillators

Test apparatus: e, l, m, n.

(i) The only setting up procedures that are described are those which are necessary to achieve minimum modulation distortion and best deviation accuracy. To make these adjustments the complete r. f. unit assembly must be removed from the instrument (see Sect. 5.5) and the particular oscillator unit reconnected using the extension leads provided.

Identify the scale positions corresponding to each of the tapping points on the tracking potentiometer. Connect the multimeter, to measure resistance, between the slider of the tracking potentiometer and each of its flying leads, in turn. Adjust the oscillator FREQUENCY control until the resistance indicated is a minimum. Note the scale position, using the logging scale as an aid to precise location.

Turn the CARRIER Mode switch to F. M., the SET Full Scale and SET ZERO controls to mid-travel and the ΔF control to zero. Set the modulation frequency to 1 kHz.

Connect the modulation meter to the R. F. OUTPUT socket and the distortion factor meter to the l. f. output terminals of the modulation meter.

(ii) This procedure applies to all oscillators except the 10-90 MHz unit.

Set the oscillator frequency control to the position corresponding to tapping point 1.

Connect all the leads from the tracking potentiometer RV2 to terminals 1 and 2 of the resistor chain.

Adjust the SET DEVIATION control so that the deviation, indicated by the modulation meter, is the scale maximum (100 kHz or 300 kHz) for the particular range under test. Adjust RV1 for minimum distortion.

(iii) The 10-90 MHz oscillator unit requires a different procedure from that described in (ii).

Connect all the flying leads from the f. m. tracking potentiometer RV2 to terminals 17 and 18. Connect lead 1 from the distortion tracking potentiometer to tag 1. Set the oscillator frequency control to the position corresponding to tapping point 1. Tune the modulation meter to the oscillator frequency and adjust the SET DEVIATION control so that the deviation, indicated by the modulation meter, is 100 kHz.

Measure the distortion and move lead 1 to the tag that gives minimum distortion. Reset the oscillator frequency control, in turn, to the position corresponding to tapping points 2 and 3 and at each connect the flying lead for minimum

For Service Manuals Contact
 MAURITRON TECHNICAL SERVICES
 8 Cherry Tree Rd, Chinnor
 Oxon OX9 4QY
 Tel:- 01844-351694 Fax:- 01844-352554
 Email:- enquiries@mauritron.co.uk

Fig. 5.16 Test apparatus arranged for setting minimum distortion

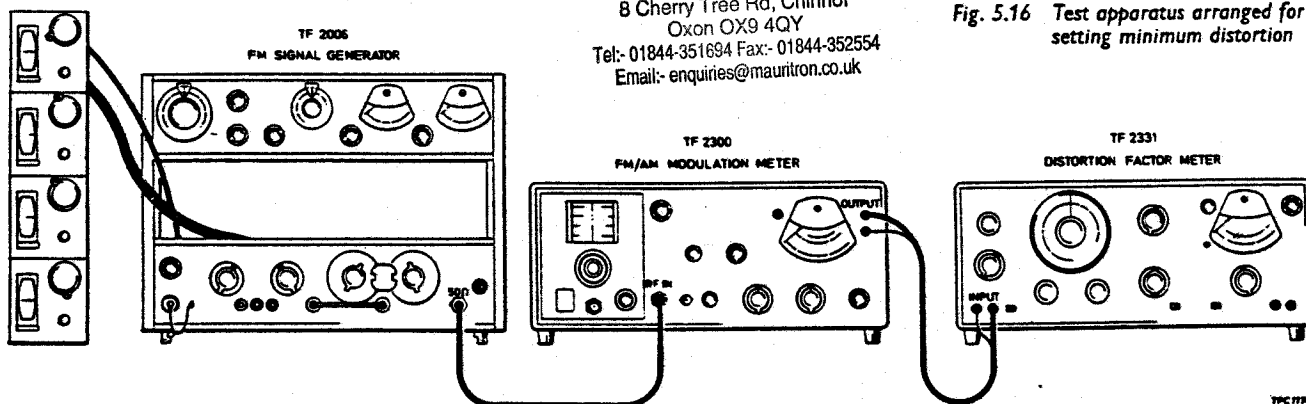

distortion. Return to tapping point 1 and check the setting of that lead. Continue the selection process at tapping points 4 to 16.

(iv) Adjust the SET DEVIATION and F. M. RANGE controls so that the Modulation and Calibrator Monitor registers the scale maximum for the oscillator unit.

With all the tracking potentiometer flying leads connected to terminals 1 and 2 of the resistor chain (terminals 17 and 18 for 10-90 MHz unit), tune the oscillator to all positions corresponding to the tapping points, in turn, and measure the deviation with the modulation meter, TF 2300.

The measurements will identify the tuning positions with the greatest and with the least sensitivity. Take the tracking potentiometer flying lead from the tapping point corresponding to the position having the greatest sensitivity and connect it to terminal 15 (terminal 31 on the 10-90 MHz range). Similarly connect the lowest sensitivity flying lead to terminal 2 (terminal 18 on the 10-90 MHz range).

Replace R17 (R32 on the 10-90 MHz range) with a 2.2 k Ω variable resistor, tune the oscillator to the previously determined position of greatest

sensitivity and adjust the variable resistor so that the deviation indicated by the modulation meter, TF 2300, is the scale maximum.

Replace R1 (R16 on the 10-90 MHz range) with a 2.2 k Ω variable resistor, tune the oscillator to the previously determined position of least sensitivity and adjust the variable resistor so that the deviation indicated by the modulation meter, TF 2300, is the scale maximum.

Measure the values of the two variable resistors and fit fixed resistors of the nearest preferred values in their places.

Remove all the flying leads from the f. m. tracking network, tune the oscillator to the position corresponding to tapping point 1. Select the position for lead 1 (lead 17 on the 10-90 MHz range) that gives deviation indicated on the modulation meter, TF 2300, nearest to the scale maximum. Repeat the procedure to select terminals for leads 2 and 3. Retune to position 1 and check the setting for lead 1. Continue the selection procedure for leads 4 to 16 (20 to 32 on the 10-90 MHz range).

Check the deviation over the whole r. f. range and adjust RV3 for optimum overall accuracy.

For Service Manuals Contact
MAURITRON TECHNICAL SERVICES
8 Cherry Tree Rd, Chinnor
Oxon OX9 4QY
Tel: 01844-351694 Fax: 01844-352554
Email: enquiries@mauritron.co.uk



Index to units

<i>Unit number</i>	<i>Stock list</i>	<i>Description</i>	<i>Parts list page</i>	<i>Circuit diagram Fig.</i>
1	TM 8873	Power unit regulator	59	7.14
2	TM 8868	FM/ ΔF drive	60	7.10
3	TM 8876	Reactor linearizer	60	7.10
4	TM 8870	Modulation oscillator series tuning	62	7.8
5	TM 8871	Modulation oscillator	62	7.8
6	TM 8874	A. L. C. and A. M.	62	7.6
7	TM 8872	Crystal calibrator metering	63	7.10 & 7.11
8	TM 8870/1	Modulation oscillator shunt tuning	64	7.8
9	TM 8846	4-10 MHz oscillator	64	7.1
10	TM 8865	4-10 MHz oscillator & leveller board	65	7.1
11	TM 8904	4-10 MHz tracking	65	7.1
12	TM 8842	10-90 MHz oscillator	66	7.2
13	TM 8849	10-90 MHz oscillator board	66	7.2
14	TM 8850	10-90 MHz leveller & carrier filter	67	7.2
15	TM 8899	10-90 MHz distortion tracking	67	7.2
16	TM 8900	10-90 MHz f. m. tracking	67	7.2
17	TM 8843	88-220 MHz oscillator	68	7.3
18	TM 8853	88-220 MHz oscillator board	69	7.3
19	TM 8854	88-220 MHz leveller & carrier filter	69	7.3
20	TM 8901	88-220 MHz tracking	69	7.3
21	TM 8844	215-500 MHz oscillator	69	7.4
22	TM 8857	215-500 MHz oscillator board	70	7.4
23	TM 8858	215-500 MHz leveller & carrier filter	71	7.4
24	TM 8902	215-500 MHz tracking	71	7.4
25	TM 8845	440-1000 MHz oscillator	71	7.5

Index *continued*

<i>Unit number</i>	<i>Stock list</i>	<i>Description</i>	<i>Parts list page</i>	<i>Circuit diagram Fig.</i>
26	TM 8861	440-1000 MHz oscillator board	72	7.5
27	TM 8862	440-1000 MHz leveller & carrier filter	72	7.5
28	TM 8903	440-1000 MHz tracking	72	7.5
29	TM 8877	Coaxial switch & carrier level monitor	73	7.6
30	TM 8070/1	Coarse attenuator	74	7.15
31	TM 8071/1	Fine attenuator	74	7.15
32	TM 8879	Crystal calibrator	74	7.11
33	TM 8880	Standard frequency generator	75	7.11
34	TM 8881	Amplifier & mixer	76	7.11
35	TM 8882	Filters section 'A'	77	7.13
36	TM 8883	Filters section 'B'	77	7.13
37	TM 8885	Power supply (excluding board)	77	7.14
38	TM 8866	Top front panel	78	7.16
39	TM 8867	Top mother board	78	7.16
40	TM 8875	Bottom mother board	79	7.18
41	TM 9111	Bottom front panel	79	7.18
		Miscellaneous	79	-

For Service Manuals Contact
 MAURITRON TECHNICAL SERVICES
 8 Cherry Tree Rd, Chinnor
 Oxon OX9 4QY
 Tel: 01844-351694 Fax: 01844-352554
 Email: enquiries@mauritron.co.uk

Replaceable parts

Introduction

Each of the printed boards and other sub-assemblies in this instrument has been allocated a unit identification number in the sequence ① to ④, which wherever practicable is marked upon it. The complete circuit reference for a component carries its unit number as a prefix, e.g. 6R15.

For convenience in the text and on the circuit diagrams, the circuit reference is abbreviated by dropping the prefix, except where there is risk of ambiguity. When ordering spare parts or in any other correspondence, be sure to quote the complete circuit reference.

This section lists the components of each unit in alpha-numerical order of the complete circuit reference. The following abbreviations are used:-

C	: capacitor
Carb	: carbon
Cer	: ceramic
Elec	: electrolytic
FS	: fuse
JK	: jack
L	: inductor
M	: meter
Met	: metal
Min	: minimum
MR	: semiconductor diode
Ox	: oxide
PL	: plug
Plas	: plastic
R	: resistor
RV	: variable resistor
S	: switch
SKT	: socket
T	: transformer
TE	: total excursion
TH	: thermistor
Var	: variable
VT	: transistor
WW	: wirewound
X	: crystal
∅	: lead through
†	: value selected during test; nominal value shown
W	: resistor rating at 70 °C
W*	: resistor rating at 55 °C

Some components are described as printed; these form an integral part of a circuit board and cannot be replaced separately.

Ordering

When ordering replacement parts, address the order to our Service Division (for address see rear cover) or nearest Agent. Specify the following information for each part required.

- (1) Type and serial number of instrument.
- (2) Complete circuit reference.
- (3) Description.
- (4) M.I. code number.

If a part is not listed, state its function, location and description when ordering.

Unit ① TM 8873 Power Unit Regulator

When ordering, prefix circuit reference with 1

Circuit reference	Description	M.I. code
	Complete board	44683-507
C1	Elec 1 μ F +100-20% 50V	26414-106
C2	Elec 100 μ F +100-20% 25V	26423-327
C3	Elec 50 μ F +100-20% 50V	26423-319
C4	Elec 5 μ F +100-20% 50V	26414-114
MR1	1N540	28357-048
MR2	1N540	28357-048
MR3	1N540	28357-048
MR4	1N540	28357-048
MR5	ZOB 7.5	28371-608
MR6	ZOB 7.5	28371-608
MR7	VR 625F	28371-491
MR8	VR 35F	28371-291
MR9	1S44	28357-548
MR10	ZOB 6.8	28371-548
R1	Carb 100 Ω 10% $\frac{1}{2}$ W	24342-050
R2	Carb 15k Ω 5% $\frac{1}{2}$ W	24234-114
R3	WW 1k Ω 5% 3W	25125-080
R4	WW 1.5 Ω 5% 2 $\frac{1}{2}$ W	25123-002
R5 †	Carb 3.9k Ω 5% $\frac{1}{2}$ W	24232-096
R6	Carb 22k Ω 5% $\frac{1}{2}$ W	24234-118

When ordering, prefix circuit reference with 1

Circuit reference	Description	M.I. code
R7	Carb 1k Ω 5% $\frac{1}{2}$ W	24232-080
R8	Carb 100 Ω 10% $\frac{1}{2}$ W	24342-050
R9	Carb 100 Ω 10% $\frac{1}{2}$ W	24342-050
R10	WW 2.2k Ω 5% 6W	25125-088
R11 †	Carb 220 Ω 5% $\frac{1}{2}$ W	24232-058
R12	Carb 330 Ω 5% $\frac{1}{2}$ W	24232-063
R13	Carb 2.2k Ω 1% $\frac{1}{2}$ W	24134-220
VT1	TM 1614	28435-488
VT2	TM 1614	28435-488

Unit ② TM 8868 FM/ Δ F Drive

When ordering, prefix circuit reference with 2

	Complete board	44683-506
C1	Elec 100 μ F +100-20% 6V	26417-154
R1	Met ox 1k Ω 7% TE $\frac{1}{2}$ W	24552-080
R2	Met ox 10k Ω 7% TE $\frac{1}{2}$ W	24552-110
R3	Met ox 2k Ω 7% TE $\frac{1}{2}$ W	24552-087
R4	Met ox 510 Ω 7% TE $\frac{1}{2}$ W	24552-071
R5	Carb 4.85k Ω 1% $\frac{1}{2}$ W	24134-485
R6	Met ox 7.5k Ω 7% TE $\frac{1}{2}$ W	24552-107
R7	Met ox 12k Ω 7% TE $\frac{1}{2}$ W	24552-112
R8	Met ox 4.7k Ω 7% TE $\frac{1}{2}$ W	24552-100
R9	Met ox 6.8k Ω 7% TE $\frac{1}{2}$ W	24552-106
R10	Met ox 1.5k Ω 7% TE $\frac{1}{2}$ W	24552-084
R11	Met ox 1k Ω 7% TE $\frac{1}{2}$ W	24552-080
R12	Met ox 18k Ω 7% TE $\frac{1}{2}$ W	24552-116
R13	Met ox 2k Ω 7% TE $\frac{1}{2}$ W	24552-087
R14	Met ox 2.2k Ω 7% TE $\frac{1}{2}$ W	24552-088
R15	Met ox 330 Ω 7% TE $\frac{1}{2}$ W	24552-063
R16 †	Met ox 33 Ω 7% TE $\frac{1}{2}$ W	24552-033
R17	Met ox 1k Ω 7% TE $\frac{1}{2}$ W	24552-080
R18	Met ox 680 Ω 7% TE $\frac{1}{2}$ W	24552-076
R19	Met ox 1k Ω 7% TE $\frac{1}{2}$ W	24552-080
R20	Met ox 10k Ω 7% TE $\frac{1}{2}$ W	24552-110
R21	Met ox 220k Ω 7% TE $\frac{1}{2}$ W	24552-143

When ordering, prefix circuit reference with 2

Circuit reference	Description	M.I. code
R22	Met ox 58 Ω 7% TE $\frac{1}{2}$ W	24552-043
R23	Met ox 220 Ω 7% TE $\frac{1}{2}$ W	24552-058
RV1	Carb 100 Ω 20% $\frac{1}{2}$ W	25611-002
RV2	Carb 1k Ω 20% $\frac{1}{2}$ W	25611-014
RV3	Carb 100 Ω 20% $\frac{1}{2}$ W	25611-002
RV4	Carb 4.7k Ω 20% $\frac{1}{2}$ W	25611-022
RV5	Carb 220 Ω 20% $\frac{1}{2}$ W	25611-006
RV6	Carb 470 Ω 20% $\frac{1}{2}$ W	25611-010
RV7	Carb 1k Ω 20% $\frac{1}{2}$ W	25611-014
RV8	Carb 220 Ω 20% $\frac{1}{2}$ W	25611-006

VT1	2N3702	28433-488
VT2	2N2925	28453-572
VT3	BSX20	28452-197
VT4	BSX20	28452-197
VT5	BSX20	28452-197
VT6	2N3702	28433-488
VT7	BCY72	28433-487

For Service Manuals Contact
MAURITRON TECHNICAL SERVICES
 B Cherry Tree Rd, Chinnor
 Oxon OX9 4QY
 Tel: 01844-851634 Fax: 01844-352554
 Email: enquiries@mauritron.co.uk

Unit ③ TM 8876 Reactor Linearizer

When ordering, prefix circuit reference with 3

	Complete board	44641-011
C1	Cer 0.1 μ F +50-20% 30V	26383-031
C2	Cer 22pF \pm 0.25pF 750V	26324-715
C3	Cer 0.1 μ F +50-20% 30V	26383-031
C4	Cer 15pF \pm 0.25pF 750V	26324-712
MR1	1S44	28357-548
MR2	1S44	28357-548
MR3	1S44	28357-548
MR4	1S44	28357-548
MR5	1S44	28357-548
MR6	1S44	28357-548

For symbols and abbreviations see introduction to this chapter

When ordering, prefix circuit reference with 3

When ordering, prefix circuit reference with 3

Circuit reference	Description	M.I. code	Circuit reference	Description	M.I. code
MR7	1S44	28357-548	R30	Met ox 7.5kΩ 7% TE 1/2W	24552-107
MR8	1S44	28357-548	R31	Met ox 5.6kΩ 7% TE 1/2W	24552-103
MR9	1S44	28357-548	R32	Met ox 4.7kΩ 7% TE 1/2W	24552-100
MR10	1S44	28357-548	R33	Met ox 4.3kΩ 7% TE 1/2W	24552-097
MR11	1S44	28357-548	R34	Met ox 1.8kΩ 7% TE 1/2W	24552-086
MR12	1S44	28357-548	R35	Met ox 1.2kΩ 7% TE 1/2W	24552-082
MR13	1S44	28357-548	R36	Met ox 750Ω 7% TE 1/2W	24552-077
MR14	1S44	28357-548	R37	Met ox 22kΩ 7% TE 1/2W	24552-118
			R38	Met ox 2kΩ 7% TE 1/2W	24552-087
			R39	Met ox 6.2kΩ 7% TE 1/2W	24552-104
R1	Met ox 220Ω 7% TE 1/2W	24552-058	R40	Met ox 2.2kΩ 7% TE 1/2W	24552-088
R2	Met ox 22kΩ 7% TE 1/2W	24552-118	R41	Met ox 1kΩ 7% TE 1/2W	24552-080
R3	Met ox 220Ω 7% TE 1/2W	24552-058	R42	Met ox 1kΩ 7% TE 1/2W	24552-080
R4	Met ox 15kΩ 7% TE 1/2W	24552-114	R43	Met ox 1kΩ 7% TE 1/2W	24552-080
R5	Met ox 100kΩ 7% TE 1/2W	24552-135	R44	Met ox 100Ω 7% TE 1/2W	24552-050
R6	Met ox 10Ω 7% TE 1/2W	24552-020	R45	Met ox 100Ω 7% TE 1/2W	24552-050
R7	Met ox 220kΩ 7% TE 1/2W	24552-143	R46	Met ox 16kΩ 7% TE 1/2W	24552-115
R8	Met ox 4.7kΩ 7% TE 1/2W	24552-100			
R9	Met ox 56Ω 7% TE 1/2W	24552-040			
R10	Met ox 33Ω 7% TE 1/2W	24552-033			
R11	Met ox 43Ω 7% TE 1/2W	24552-036			
R12	Met ox 43Ω 7% TE 1/2W	24552-036	RV1	Carb 22kΩ 20% 1/4W	25611-030
R13	Met ox 43Ω 7% TE 1/2W	24552-036	RV2	Carb 100Ω 20% 1/4W	25611-002
R14	Met ox 33Ω 7% TE 1/2W	24552-033	RV3	Carb 10kΩ 20% 1/4W	25611-025
R15	Met ox 33Ω 7% TE 1/2W	24552-033	RV4	Carb 47kΩ 20% 1/4W	25611-034
R16	Met ox 33Ω 7% TE 1/2W	24552-033			
R17	Met ox 22Ω 7% TE 1/2W	24552-028			
R18	Met ox 22Ω 7% TE 1/2W	24552-028			
R19	Met ox 22Ω 7% TE 1/2W	24552-028			
R20	Met ox 22Ω 7% TE 1/2W	24552-028	TH1	CZ3	25683-644
R21	Met ox 22Ω 7% TE 1/2W	24552-028			
R22	Met ox 22Ω 7% TE 1/2W	24552-028			
R23	Met ox 510Ω 7% TE 1/2W	24552-071			
R24	Met ox 27kΩ 7% TE 1/2W	24552-120	VT1	MPS3640	28431-766
R25	Met ox 22kΩ 7% TE 1/2W	24552-118	VT2	MPS3640	28431-766
R26	Met ox 18kΩ 7% TE 1/2W	24552-116	VT3	2N3663	28451-692
R27	Met ox 15kΩ 7% TE 1/2W	24552-114	VT4	2N3663	28451-692
R28	Met ox 12kΩ 7% TE 1/2W	24552-112	VT5	BSX20	28452-197
R29	Met ox 9.1kΩ 7% TE 1/2W	24552-109	VT6	2N3663	28451-692

For symbols and abbreviations see introduction to this chapter

Unit 4 TM 8870 Mod. Osc. Series Tuning

When ordering, prefix circuit reference with 4

Circuit reference	Description	M.I. code
	Complete board	44688-606
C1	Plas 0.372 μ F 2% 125V	26516-881
C2	Plas 0.118 μ F 2% 125V	26516-857
C3	Plas 0.0372 μ F 2% 125V	26516-816
C4	Plas 0.0118 μ F 2% 125V	26516-722
C5	Plas 0.00372 μ F 2% 125V	26516-624
C6	Plas 0.00114 μ F 2% 125V	26516-499
C7 †	Plas 350pF 2% 125V	26516-378
C8	Var air 2.5/13.4pF	26817-238
C9 †	Plas 110pF 2% 125V	26516-254
C10	Var air 2.5/13.4pF	26817-238
R1	Met ox 6.2k Ω 7% TE $\frac{1}{2}$ W	24552-104
RV1	Carb 1k Ω 20% $\frac{1}{4}$ W	25611-014

Unit 5 TM 8871 Modulation Oscillator

When ordering, prefix circuit reference with 5

	Complete board	44624-103
C1	Elec 25 μ F +100-20% 50V	26423-313
C2	Elec 200 μ F +100-20% 6V	26423-333
C3	Elec 100 μ F +100-20% 25V	26423-327
C4	Elec 50 μ F +100-20% 25V	26423-317
C5	Elec 1000 μ F +100-20% 18V	26417-183
C6	Elec 250 μ F +100-20% 25V	26417-167
C7	Cer 47pF 2% 750V	26324-833
MR1	ZB7.5	28371-606
MR2	HG-1005	28323-035
MR3	HG-1005	28323-035
MR4	ZB12	28372-146
R1	Met ox 10k Ω 7% TE $\frac{1}{2}$ W	24552-110
R2	Met ox 9.1k Ω 7% TE $\frac{1}{2}$ W	24552-109
R3	Met ox 11k Ω 7% TE $\frac{1}{2}$ W	24552-111
R4	Met ox 6.8k Ω 7% TE $\frac{1}{2}$ W	24552-106

When ordering, prefix circuit reference with 5

Circuit reference	Description	M.I. code
R5	Met ox 6.8k Ω 7% TE $\frac{1}{2}$ W	24552-106
R6	Met ox 3.9k Ω 7% TE $\frac{1}{2}$ W	24552-096
R7	Met ox 750 Ω 7% TE $\frac{1}{2}$ W	24552-077
R8	Met ox 13k Ω 7% TE $\frac{1}{2}$ W	24552-113
R9	Met ox 1.5k Ω 7% TE $\frac{1}{2}$ W	24552-084
R10	Met ox 510 Ω 7% TE $\frac{1}{2}$ W	24552-071
R11	Met ox 1k Ω 7% TE $\frac{1}{2}$ W	24552-080
R12	Met ox 16k Ω 7% TE $\frac{1}{2}$ W	24552-115
R13	Met ox 1k Ω 7% TE $\frac{1}{2}$ W	24552-080
R14	Met ox 5.6k Ω 7% TE $\frac{1}{2}$ W	24552-103
R15	Met ox 10k Ω 7% TE $\frac{1}{2}$ W	24552-110
R16	Met ox 15k Ω 7% TE $\frac{1}{2}$ W	24552-114
R17	Met ox 1.5k Ω 7% TE $\frac{1}{2}$ W	24552-084
R18	Met ox 100k Ω 7% TE $\frac{1}{2}$ W	24552-135
RV1	Carb 4.7k Ω 20% $\frac{1}{4}$ W	25611-022
RV2	Carb 1k Ω 20% $\frac{1}{4}$ W	25611-014
RV3	Carb 100 Ω 20% $\frac{1}{4}$ W	25611-002

Unit 6 TM 8874 A.L.C. and Amplitude Modulator

When ordering, prefix circuit reference with 6

	Complete board	44642-109
C1	Elec 100 μ F +100-20% 25V	26423-327
C2	Elec 100 μ F +100-20% 25V	26423-327
C3	Elec 2 μ F +100-20% 25V	26414-109
C4	Plas 0.001 μ F 2% 500V	26516-489
C5	Elec 2 μ F +100-20% 25V	26414-109
C6	Elec 12 μ F +100-20% 50V	26423-309

For symbols and abbreviations see introduction to this chapter

When ordering, prefix circuit reference with 6

Circuit reference	Description	M.I. code
R1	Met ox 4.7kΩ 7% TE ½W	24552-100
R2	Met ox 1.5kΩ 7% TE ½W	24552-084
R3	Met ox 20kΩ 7% TE ½W	24552-117
R4	Met ox 3.3kΩ 7% TE ½W	24552-094
R5	Met ox 4.7kΩ 7% TE ½W	24552-100
R6	Met ox 4.7kΩ 7% TE ½W	24552-100
R8	Met ox 220kΩ 7% TE ½W	24552-143
R9	Met ox 150kΩ 7% TE ½W	24552-139
R10	Met ox 270kΩ 7% TE ½W	24552-146
R11	Met ox 10kΩ 7% TE ½W	24552-110
R12	Met ox 10kΩ 7% TE ½W	24552-110
R13	Met ox 4.7kΩ 7% TE ½W	24552-126
R14	Met ox 4.7kΩ 7% TE ½W	24552-100
R15	Met ox 10kΩ 7% TE ½W	24552-110
R16	Met ox 270kΩ 7% TE ½W	24552-146
R17	Met ox 4.7kΩ 7% TE ½W	24552-100
R18	Met ox 4.7kΩ 7% TE ½W	24552-100
R19	WW 150Ω 5% 3W	25125-054
R20	Met ox 2.2kΩ 7% TE ½W	24552-088
R21	Met ox 1kΩ 7% TE ½W	24552-080
R22	Met ox 10Ω 7% TE ½W	24552-020
R23	Met ox 10Ω 7% TE ½W	24552-020
R24	Met ox 10kΩ 7% TE ½W	24552-110
R25	Met ox 4.7kΩ 7% TE ½W	24552-100
R26	Met ox 470Ω 7% TE ½W	24552-069
RV1	Carb 4.7kΩ 20% ¼W	25611-034
RV2	Carb 1MΩ 20% ¼W	25611-050
RV3	Carb 470kΩ 20% ¼W	25611-046
RV4	Carb 1MΩ 20% ¼W	25611-050
RV5	Carb 4.7kΩ 20% ¼W	25611-022
VT1	2N3702	28433-488
VT2	2N3702	28433-488
VT3	2N3702	28433-488
VT4	BSX20	28452-197
VT5	BSX20	28452-197
VT6	BSX20	28452-197
VT7	BSX20	28452-197
VT8	BSX20	28452-197
VT9	BSX20	28452-197

Unit **7** TM 8872 Crystal Cal. Metering

When ordering, prefix circuit reference with 7

Circuit reference	Description	M.I. code
	Complete board	44682-006
C1	Plas 0.68μF 10% 250V	26512-272
C2	Elec 25μF +100-20% 50V	26423-313
C3	Cer 47pF 2% 750V	26324-833
C4	Elec 12μF +100-20% 50V	26423-309
C5	Elec 12μF +100-20% 50V	26423-309
C6	Plas 1μF 10% 250V	26512-280
C7	Paper 0.004μF 10% 250V	26174-137
C8	Elec 50μF +100-20% 25V	26417-152
C9	Plas 0.47μF 10% 250V	26512-264
C10	Plas 0.47μF 10% 250V	26512-264
C11	Plas 2μF 10% 250V	26512-288
MR1	HG5004	28332-465
MR2	HG5004	28332-465
MR3	1S44	28357-548
MR4	1S44	28357-548
MR5	1S44	28357-548
MR6	1S44	28357-548
MR7	1S44	28357-548
MR8	1S44	28357-548
R1	Met ox 20kΩ 7% TE ½W	24552-117
R2	Met ox 3kΩ 7% TE ½W	24552-093
R3	Met ox 470Ω 7% TE ½W	24552-069
R4	Met ox 750Ω 7% TE ½W	24552-077
R5	Met ox 12kΩ 7% TE ½W	24552-112
R6	Met ox 30kΩ 7% TE ½W	24552-121
R7	Met ox 1.8kΩ 7% TE ½W	24552-086
R8	Met ox 2kΩ 7% TE ½W	24552-087
R9	Met ox 2.2kΩ 7% TE ½W	24552-088
R10	Met ox 9.1kΩ 7% TE ½W	24552-109
R11	Met ox 470Ω 7% TE ½W	24552-069
R12	Met ox 1.5kΩ 7% TE ½W	24552-084
R13	Met ox 6.8kΩ 7% TE ½W	24552-106
R14	Met ox 3.3kΩ 7% TE ½W	24552-094
R15	Carb 2.2MΩ 10% ½W*	24342-174
R16	Carb 1MΩ 10% ½W*	24342-166

For Service Manuals Contact
MAURITRON TECHNICAL SERVICES
 8 Cherry Tree Rd, Chinnor
 Oxon OX9 4QY
 Tel: 01844-351684 Fax: 01844-352554
 Email: enquiries@mauritron.co.uk

For symbols and abbreviations see introduction to this chapter

When ordering, prefix circuit reference with 7

Circuit reference	Description	M.I. code
R17	Carb 1M Ω 10% $\frac{1}{2}$ W	24342-166
R18	Met ox 220k Ω 7% TE $\frac{1}{2}$ W	24552-143
R19	Met ox 68k Ω 7% TE $\frac{1}{2}$ W	24552-131
R20	Carb 1M Ω 10% $\frac{1}{2}$ W	24342-166
RV1	Carb 4.7k Ω 20% $\frac{1}{4}$ W	25611-022
RV2	Carb 1k Ω 20% $\frac{1}{4}$ W	25611-014
RV3	Carb 4.7k Ω 20% $\frac{1}{4}$ W	25611-034
RV4	Carb 4.7k Ω 20% $\frac{1}{4}$ W	25611-034
VT1	BSX20	28452-197
VT2	BSX20	28452-197
VT3	BSX20	28452-197
VT4	BSX20	28452-197
VT5	BSX20	28452-197
VT6	2N3702	28433-488
VT7	Silicon NPN	28453-552

Unit 8 TM 8870/1 Mod. Osc. Shunt Tuning

When ordering, prefix circuit reference with 8

	Complete board	44688-607
C1	Plas 0.372 μ F 2% 125V	26516-881
C2	Plas 0.118 μ F 2% 125V	26516-857
C3	Plas 0.0372 μ F 2% 125V	26516-816
C4	Plas 0.0118 μ F 2% 125V	26516-722
C5	Plas 0.00372 μ F 2% 125V	26516-624
C6	Plas 0.00114 μ F 2% 125V	26516-499
C7 †	Plas 330pF 2% 125V	26516-369
C8	Var air 2.5/13.4pF	26817-238
C9 †	Plas 82pF \pm 2pF 125V	26516-222
C10	Var air 2.5/13.4pF	26817-238
R1	Met ox 6.2k Ω 7% TE $\frac{1}{2}$ W	24552-104
RV1	Carb 1k Ω 20% $\frac{1}{4}$ W	25611-014

Unit 9 TM 8846 4-10 MHz Oscillator

When ordering, prefix circuit reference with 9

Circuit reference	Description	M.I. code
C1	Cer 0.0047 μ F +80-20% 500V	26373-665
C2	Cer 56pF 20% 500V	26373-855
C3	Cer 12pF 20% 500V	26333-151
C4	Cer 12pF 20% 500V	26333-151
C5	Cer 0.0047 μ F +80-20% 500V	26373-665
C6	Plas 56pF \pm 2pF 500V	26516-183
C7	Plas 56pF \pm 2pF 500V	26516-183
C8	Cer 47pF 2% 750V	26324-833
C9	Plas 300pF 2% 500V	26516-364
C10	Plas 300pF 2% 500V	26516-364
C11	Cer 0.0047 μ F +80-20% 500V	26373-665
C12	Cer 56pF 20% 500V	26373-855
C13	Cer 12pF 20% 500V	26333-151
C14	Cer 12pF 20% 500V	26333-151
C15	Cer 0.0047 μ F +80-20% 500V	26373-665
C16	Plas 470pF 2% 500V	26516-410
C17	Plas 470pF 2% 500V	26516-410
C18	Cer 0.0047 μ F +80-20% 500V	26373-665
C19	Cer 56pF 20% 500V	26373-855
C20	Cer 12pF 20% 500V	26333-151
C21	Cer 12pF 20% 500V	26333-151
C22	Cer 0.0047 μ F +80-20% 500V	26373-665

L1	40 μ H	44257-212
L2	910 μ H	44268-606
L3	877 μ H	44268-611
L4	877 μ H	44268-611
L5	40 μ H	44257-212
L6	40 μ H	44257-212
L7	910 μ H	44268-606
L8	1774 μ H	44268-610
L9	1774 μ H	44268-610
L10	40 μ H	44257-212

For symbols and abbreviations see introduction to this chapter

When ordering, prefix circuit reference with 9

Circuit reference	Description	M.I. code
R1	Met ox 4.7k Ω 7% TE $\frac{1}{2}$ W	24552-100
R2	Met ox 2k Ω 7% TE $\frac{1}{2}$ W	24552-087
R3	Met ox 2k Ω 7% TE $\frac{1}{2}$ W	24552-087
RV2	Special 100k Ω	44368-006
SKTA	12 pole edge connector	23435-051
SKTB	Elbow socket TNC	23444-773

Unit (10) TM 8865 4-10 MHz Oscillator and Leveller Board

When ordering, prefix circuit reference with 10

C1	Cer 0.1 μ F +50-25% 30V	26383-031
C2	Cer 0.1 μ F +50-25% 30V	26383-031
C3	Cer 0.01 μ F +80-20% 100V	26383-055
C4 †	Cer 22pF \pm 0.25pF 750V	26324-712
C5	Cer 47pF 2% 750V	26324-833
C6	Mica 200pF 1% 350V	26268-329
C7	Plas 120pF 2% 500V	26516-268
C8 †	Cer 10pF \pm 0.25pF 750V	26324-709
C9	Plas 300pF 2% 500V	26516-364
C10 †	Mica 0.0018 μ F 5% 200V	26268-366
C11	Plas 0.0018 μ F 2% 125V	26516-543
C12	Cer 0.1 μ F +50-25% 30V	26383-031
L1	Tuning	44147-802
L2	Trimmer	44247-635
L3	530 μ H	44266-606
L4	227 μ H	44268-609
L5	227 μ H	44268-609
L6	4.7 μ H	23642-553
MR1	HG5004	28332-465
MR2	V56E	28381-605

When ordering, prefix circuit reference with 10

Circuit reference	Description	M.I. code
R1	Met ox 1k Ω 7% TE $\frac{1}{2}$ W	24552-080
R2	Met ox 6.8k Ω 7% TE $\frac{1}{2}$ W	24552-106
R3	Met ox 470 Ω 7% TE $\frac{1}{2}$ W	24552-069
R4	Met ox 100 Ω 7% TE $\frac{1}{2}$ W	24552-050
TH1	A52	25683-251
TH2	A52	25683-251
VT1	2N3710	28453-818

Unit (11) TM 8904 4-10 MHz Tracking

When ordering, prefix circuit reference with 11

C1 †	Plas 180pF 2% 500V	26516-308
R1 †	Met ox 620 Ω 7% TE $\frac{1}{2}$ W	24552-074
R2	Met ox 68 Ω 7% TE $\frac{1}{2}$ W	24552-043
R3	Met ox 68 Ω 7% TE $\frac{1}{2}$ W	24552-043
R4	Met ox 68 Ω 7% TE $\frac{1}{2}$ W	24552-043
R5	Met ox 68 Ω 7% TE $\frac{1}{2}$ W	24552-043
R6	Met ox 68 Ω 7% TE $\frac{1}{2}$ W	24552-043
R7	Met ox 68 Ω 7% TE $\frac{1}{2}$ W	24552-043
R8	Met ox 68 Ω 7% TE $\frac{1}{2}$ W	24552-043
R9	Met ox 68 Ω 7% TE $\frac{1}{2}$ W	24552-043
R10	Met ox 68 Ω 7% TE $\frac{1}{2}$ W	24552-043
R11	Met ox 68 Ω 7% TE $\frac{1}{2}$ W	24552-043
R12	Met ox 68 Ω 7% TE $\frac{1}{2}$ W	24552-043
R13	Met ox 68 Ω 7% TE $\frac{1}{2}$ W	24552-043
R14	Met ox 68 Ω 7% TE $\frac{1}{2}$ W	24552-043
R15	Met ox 68 Ω 7% TE $\frac{1}{2}$ W	24552-043
R16	Met ox 68 Ω 7% TE $\frac{1}{2}$ W	24552-043
R17 †	Met ox 470 Ω 7% TE $\frac{1}{2}$ W	24552-069
R18 †	Met ox 27k Ω 7% TE $\frac{1}{2}$ W	24552-120
RV1	Carb 10k Ω 20% $\frac{1}{2}$ W	25611-025
RV3	Carb 470 Ω 20% $\frac{1}{2}$ W	25611-010

For symbols and abbreviations see introduction to this chapter

Unit 12 TM 8842 10-90 MHz Oscillator

When ordering, prefix circuit reference with 12

Circuit reference	Description	M.I. code
C1	Cer 0.0047µF +80-20% 500V	26373-665
C2	Cer 56pF 20% 500V	26373-855
C3	Cer 12pF 20% 500V	26333-151
C4	Cer 12pF 20% 500V	26333-151
C5	Cer 0.0047µF +80-20% 500V	26373-665
C6	Plas 22pF ±2pF 500V	26516-091
C7	Plas 22pF ±2pF 500V	26516-091
C8	Cer 47pF 2% 750V	26324-833
C9	Plas 160pF 2% 500V	26516-296
C10	Plas 160pF 2% 500V	26516-296
C11	Cer 0.0047µF +80-20% 500V	26373-665
C12	Cer 56pF 20% 500V	26373-855
C13	Cer 12pF 20% 500V	26333-151
C14	Cer 12pF 20% 500V	26333-151
C15	Cer 0.0047µF +80-20% 500V	26373-665
C16	Plas 110pF 2% 500V	26516-256
C17	Plas 110pF 2% 500V	26516-256
C18	Cer 0.0047µF +80-20% 500V	26373-665
C19	Cer 56pF 20% 500V	26373-855
C20	Cer 12pF 20% 500V	26333-151
C21	Cer 12pF 20% 500V	26333-151
C22	Cer 0.0047µF +80-20% 500V	26373-665
C23	Cer 0.0047µF +80-20% 500V	26373-665
C24	Cer 0.0047µF +80-20% 500V	26373-665
C25	Special 0.002µF Part of TM 8847	
C26	Cer 0.01µF +80-20% 100V	26383-055
C27	Tuning 1-130pF } Part of TM 8847	
C28	Tuning 1-130pF }	
C29	Plas 270pF 2% 500V	26516-352
C30	Plas 270pF 2% 500V	26516-352
L1	40µH	44257-212
L2	910µH	44268-606
L3	502µH	44266-603
L4	502µH	44266-603
L5	40µH	44257-212
L6	40µH	44257-212
L7	910µH	44268-606

When ordering, prefix circuit reference with 12

Circuit reference	Description	M.I. code
L8	969µH	44268-605
L9	969µH	44268-605
L10	40µH	44257-212
L11	Tuning coil includes L12	44447-019
L12	Pick up loop (part of L11)	
L13	122µH	44268-607
L14	122µH	44268-607
R1	Met ox 4.7kΩ 7% TE ½W	24552-100
R2	Met ox 2kΩ 7% TE ½W	24552-087
R3	Met ox 2kΩ 7% TE ½W	24552-087
RV1	Special 100kΩ	44368-006
RV2	Special 100kΩ	44368-006
SKTA	12 pole edge connector	23435-051
SKTB	Elbow socket TNC	23444-773

For Service Manuals Contact
MAURITRON TECHNICAL SERVICES
 8 Cherry Tree Rd, Chinnor
 Oxon OX9 4QY
 Tel: 01844-351694 Fax: 01844-352554
 Email: enquiries@mauritron.co.uk

Unit 13 TM 8849 10-90 MHz Oscillator Board

When ordering, prefix circuit reference with 13

C1	Cer 6.8pF ±0.25pF 750V	26324-706
C2	Cer 6.8pF ±0.25pF 750V	26324-706
C3	Cer 33pF 5% 750V	26324-822
C4	Cer 33pF 5% 750V	26324-822
C5	Mica 0.001µF 1% 350V	26268-360
C6	Var Plas 0.7-3pF	26875-103
C7	Mica 100pF 1% 350V	26268-324
L1	40µH	44262-826
L2	17.5µH	44227-404
L3	17.5µH	44227-404
MR1	HG5004	28332-465
MR2	V56E	28381-605
MR3	HG5004	28332-465

When ordering, prefix circuit reference with 13

Circuit reference	Description	M.I. code
R1	Met ox 2.2k Ω 7% TE $\frac{1}{2}$ W	24552-088
R2	Met ox 3.9k Ω 7% TE $\frac{1}{2}$ W	24552-096
R3	Met ox 2.2k Ω 7% TE $\frac{1}{2}$ W	24552-088
R4	Met ox 3.9k Ω 7% TE $\frac{1}{2}$ W	24552-096
R5	Met ox 1k Ω 7% TE $\frac{1}{2}$ W	24552-088
R6	Met ox 1k Ω 7% TE $\frac{1}{2}$ W	24552-088
R7	Met ox 150 Ω 7% TE $\frac{1}{2}$ W	24552-054
VT1	2N2865	28451-768
VT2	2N2865	28451-768

Unit (14) TM 8850 10-90 MHz Leveller and Carrier Filter

When ordering, prefix circuit reference with 14

C1	Cer 0.001 μ F +40-20% 500V	26383-242
C2	Cer 0.001 μ F +40-20% 500V	26383-242
C3	Cer 0.01 μ F +80-20% 100V	26383-055
C4	Printed 21.1pF	-
C5	Printed 22.8pF	-
C6	Printed 1.97pF	-
L1	22 μ H	44253-013
L2	Printed 0.047 μ H	-
L3	0.11 μ H	44123-402
L4	Printed 0.0342 μ H	-
L5	Printed 0.0047 μ H	-
L6	Printed 0.0123 μ H	-
R1 †	Met ox 47 Ω 7% TE $\frac{1}{2}$ W	24552-037
R2	Met ox 240 Ω 7% TE $\frac{1}{2}$ W	24552-060
R3	Met ox 3.9k Ω 7% TE $\frac{1}{2}$ W	24552-096
R4	Met ox 2.2k Ω 7% TE $\frac{1}{2}$ W	24552-088
TH1	A52	25683-251
TH2	A52	25683-251
VT1	MM1613	28454-776

Unit (15) TM 8899 10-90 MHz Distortion Tracking

When ordering, prefix circuit reference with 15

Circuit reference	Description	M.I. code
C1	Plas 0.002pF 2% 125V	26516-556
R1	Met ox 3k Ω 7% TE $\frac{1}{2}$ W	24552-093
R2	Met ox 330 Ω 7% TE $\frac{1}{2}$ W	24552-063
R3	Met ox 330 Ω 7% TE $\frac{1}{2}$ W	24552-063
R4	Met ox 330 Ω 7% TE $\frac{1}{2}$ W	24552-063
R5	Met ox 330 Ω 7% TE $\frac{1}{2}$ W	24552-063
R6	Met ox 330 Ω 7% TE $\frac{1}{2}$ W	24552-063
R7	Met ox 330 Ω 7% TE $\frac{1}{2}$ W	24552-063
R8	Met ox 330 Ω 7% TE $\frac{1}{2}$ W	24552-063
R9	Met ox 330 Ω 7% TE $\frac{1}{2}$ W	24552-063
R10	Met ox 330 Ω 7% TE $\frac{1}{2}$ W	24552-063
R11	Met ox 330 Ω 7% TE $\frac{1}{2}$ W	24552-063
R12	Met ox 330 Ω 7% TE $\frac{1}{2}$ W	24552-063
R13	Met ox 330 Ω 7% TE $\frac{1}{2}$ W	24552-063
R14	Met ox 330 Ω 7% TE $\frac{1}{2}$ W	24552-063
R15	Met ox 3k Ω 7% TE $\frac{1}{2}$ W	24552-093

Unit (16) TM 8900 10-90 MHz F.M. Tracking

When ordering, prefix circuit reference with 16

C1 †	Plas 510pF 2% 500V	26516-418
R16 †	Met ox 22 Ω 7% TE $\frac{1}{2}$ W	24552-028
R17	Met ox 51 Ω 7% TE $\frac{1}{2}$ W	24552-038
R18	Met ox 51 Ω 7% TE $\frac{1}{2}$ W	24552-038
R19	Met ox 51 Ω 7% TE $\frac{1}{2}$ W	24552-038
R20	Met ox 51 Ω 7% TE $\frac{1}{2}$ W	24552-038
R21	Met ox 51 Ω 7% TE $\frac{1}{2}$ W	24552-038
R22	Met ox 51 Ω 7% TE $\frac{1}{2}$ W	24552-038
R23	Met ox 51 Ω 7% TE $\frac{1}{2}$ W	24552-038
R24	Met ox 51 Ω 7% TE $\frac{1}{2}$ W	24552-038
R25	Met ox 51 Ω 7% TE $\frac{1}{2}$ W	24552-038
R26	Met ox 51 Ω 7% TE $\frac{1}{2}$ W	24552-038

For symbols and abbreviations see introduction to this chapter

When ordering, prefix circuit reference with 16

Circuit reference	Description	M.I. code
R27	Met ox 51Ω 7% TE ½W	24552-038
R28	Met ox 51Ω 7% TE ½W	24552-038
R29	Met ox 51Ω 7% TE ½W	24552-038
R30	Met ox 51Ω 7% TE ½W	24552-038
R31	Met ox 51Ω 7% TE ½W	24552-038
R32 †	Met ox 820Ω 7% TE ½W	24552-078
R33 †	Met ox 39kΩ 7% TE ½W	24552-124
RV3	Carb 470Ω 20% ¼W	25611-010

Unit (17) TM 8843 88-220 MHz Oscillator

When ordering, prefix circuit reference with 17

C1	Cer 0.0047μF +80-20% 500V	26373-665
C2	Cer 56pF 20% 500V	26373-855
C3	Cer 56pF 20% 500V	26373-855
C4	Cer 56pF 20% 500V	26373-855
C5	Cer 0.0047μF +80-20% 500V	26373-665
C6	Cer 10pF ±0.25pF 750V	26324-709
C7	Cer 10pF ±0.25pF 750V	26324-709
C8	Cer 47pF 2% 750V	26324-833
C9	Cer 27pF 5% 750V	26324-812
C10	Cer 27pF 5% 750V	26324-812
C11	Cer 0.0047μF +80-20% 500V	26373-665
C12	Cer 56pF 20% 500V	26373-855
C13	Cer 56pF 20% 500V	26373-855
C14	Cer 56pF 20% 500V	26373-855
C15	Cer 0.0047μF +80-20% 500V	26373-665
C16	Cer 68pF 2% 750V	26324-868
C17	Cer 68pF 2% 750V	26324-868
C18	Cer 0.0047μF +80-20% 500V	26373-665
C19	Cer 56pF 20% 500V	26373-855
C20	Cer 56pF 20% 500V	26373-855
C21	Cer 56pF 20% 500V	26373-855
C22	Cer 0.0047μF +80-20% 500V	26373-665
C23	Printed 23pF	31817-001
C24	Printed 74pF	31817-002

When ordering, prefix circuit reference with 17

Circuit reference	Description	M.I. code
C25	Special 0.008μF	31881-104
C26	Cer 47pF 10% 500V	26373-815
C27	Printed 14.5pF	part of 44683-703
C28	Printed 14.5pF	
C29	Cer 0.0047μF +80-20% 500V	26373-665
C30	Plunger	part of TM 8851
C31	Tuning 1-30pF	
L1	40μH	44257-212
L2	910μH	44268-606
L3	430μH	44266-604
L4	430μH	44266-604
L5	40μH	44257-212
L6	40μH	44257-212
L7	910μH	44268-606
L8	650μH	44266-605
L9	650μH	44266-605
L10	40μH	44257-212
L11	Tuning	44223-903
MR1	HG5004	28332-465
MR2	V47E	28381-592
R1	Met ox 4.7kΩ 7% TE ½W	24552-100
R2	Met ox 2kΩ 7% TE ½W	24552-087
R3	Met ox 2kΩ 7% TE ½W	24552-087
R4	Carb 100Ω 10% 1/10W	24341-250
R5	Carb 100Ω 10% 1/10W	24341-250
RV2	Special 100kΩ	44368-006
SKTA	12 pole edge connector	23435-051
SKTB	Elbow socket TNC	23444-773
VT1	2N2857	28452-147

For Service Manuals Contact
 MAURITRON TECHNICAL SERVICES
 8 Cherry Tree Rd, Chinnor
 Oxon OX9 4QY
 Tel: 01844-331654 Fax: 01844-352554
 Email: enquiries@mauritron.co.uk

For symbols and abbreviations see introduction to this chapter

Unit (18) TM 8853 88-220 MHz Oscillator Board

When ordering, prefix circuit reference with 18

Circuit reference	Description	M.I. code
C1	Cer 0.001 μ F +80-20% 500V	26383-242
L1	16 μ H includes R1	44264-405
L2	4 μ H	44221-407
L3	16 μ H includes R6	44264-405
L4	16 μ H includes R7	44264-405
R1	4.7k Ω 10% 1W part of L1	-
R2	Met ox 150 Ω 7% TE $\frac{1}{2}$ W	24552-054
R3	Met ox 3.9k Ω 7% TE $\frac{1}{2}$ W	24552-096
R4	Met ox 1.8k Ω 7% TE $\frac{1}{2}$ W	24552-086
R5	Met ox 470 Ω 7% TE $\frac{1}{2}$ W	24552-069
R6	4.7k Ω 10% 1W part of L3	-
R7	4.7k Ω 10% 1W part of L4	-

Unit (19) TM 8854 88-220 MHz Leveller and Carrier Filter

When ordering, prefix circuit reference with 19

C1	Cer 0.001 μ F +80-20% 250V	26387-113
C2	Printed 9.08pF	-
C3	Printed 9.45pF	-
C4	Printed 10pF	-
L1	Printed 0.0077 μ H	-
L2	0.047 μ H includes R1	44223-905
L3	Printed 0.0056 μ H	-
L4	0.024 μ H includes R2	44223-904
L5	Printed 0.0019 μ H	-
L6	Pick up loop	44681-242
R1	2.2M Ω 10% $\frac{1}{2}$ W part of L2	-
R2	2.2M Ω 10% $\frac{1}{2}$ W part of L4	-
TH1	A52	25683-251
TH2	A52	25683-251

Unit (20) TM 8901 88-220 MHz Tracking

When ordering, prefix circuit reference with 20

Circuit reference	Description	M.I. code
C1 †	Plas 300pF 2% 500V	26516-364
R1 †	Met ox 3.3k Ω 7% TE $\frac{1}{2}$ W	24552-094
R2	Met ox 56 Ω 7% TE $\frac{1}{2}$ W	24552-040
R3	Met ox 56 Ω 7% TE $\frac{1}{2}$ W	24552-040
R4	Met ox 56 Ω 7% TE $\frac{1}{2}$ W	24552-040
R5	Met ox 56 Ω 7% TE $\frac{1}{2}$ W	24552-040
R6	Met ox 56 Ω 7% TE $\frac{1}{2}$ W	24552-040
R7	Met ox 56 Ω 7% TE $\frac{1}{2}$ W	24552-040
R8	Met ox 56 Ω 7% TE $\frac{1}{2}$ W	24552-040
R9	Met ox 56 Ω 7% TE $\frac{1}{2}$ W	24552-040
R10	Met ox 56 Ω 7% TE $\frac{1}{2}$ W	24552-040
R11	Met ox 56 Ω 7% TE $\frac{1}{2}$ W	24552-040
R12	Met ox 56 Ω 7% TE $\frac{1}{2}$ W	24552-040
R13	Met ox 56 Ω 7% TE $\frac{1}{2}$ W	24552-040
R14	Met ox 56 Ω 7% TE $\frac{1}{2}$ W	24552-040
R15	Met ox 56 Ω 7% TE $\frac{1}{2}$ W	24552-040
R16	Met ox 56 Ω 7% TE $\frac{1}{2}$ W	24552-040
R17 †	Met ox 1k Ω 7% TE $\frac{1}{2}$ W	24552-080
R18	Met ox 3.9k Ω 7% TE $\frac{1}{2}$ W	24552-096
RV1	Carb 10k Ω 20% $\frac{1}{4}$ W	25611-025
RV3	Carb 470 Ω 20% $\frac{1}{4}$ W	25611-010

Unit (21) TM 8844 215-500 MHz Oscillator

When ordering, prefix circuit reference with 21

C1	Cer 0.0047 μ F +80-20% 500V	26373-665
C2	Cer 56pF 20% 500V	26373-855
C3	Cer 56pF 20% 500V	26373-855
C4	Cer 56pF 20% 500V	26373-855
C5	Cer 0.0047 μ F +80-20% 500V	26373-665
C6	Cer 10pF \pm 0.25pF 750V	26324-709
C7	Cer 10pF \pm 0.25pF 750V	26324-709
C8	Cer 47pF 2% 750V	26324-833
C9	Cer 27pF 5% 750V	26324-812

For symbols and abbreviations see introduction to this chapter

When ordering, prefix circuit reference with 21

When ordering, prefix circuit reference with 21

Circuit reference	Description	M.I. code
C10	Cer 27pF 5% 750V	26324-812
C11	Cer 0.0047µF +80-20% 500V	26373-665
C12	Cer 56pF 20% 500V	26373-855
C13	Cer 56pF 20% 500V	26373-855
C14	Cer 56pF 20% 500V	26373-855
C15	Cer 0.0047µF +80-20% 500V	26373-665
C16	Plas 180pF 2% 500V	26516-308
C17	Plas 180pF 2% 500V	26516-308
C18	Cer 0.0047µF +80-20% 500V	26373-665
C19	Cer 56pF 20% 500V	26373-855
C20	Cer 56pF 20% 500V	26373-855
C21	Cer 56pF 20% 500V	26373-855
C22	Cer 0.0047µF +80-20% 500V	26373-665
C23	Special 70pF	31881-103
C24	Special 70pF	31881-103
C25	Printed 7.5pF	-
C26	Printed 15pF	-
C27	Special 26pF	part of TM 8855
C28	Cer 0.0047µF +80-20% 500V	26373-665
C29	Plunger	} part of TM 8855
C30	Tuning 5-50pF	
C31 †	Cer 2.2pF ±0.25pF 750V	26324-011
C32 †	Cer 3.3pF ±0.25pF 750V	26324-014
C33	Cer 0.001µF +80-20% 500V	26383-242
C34	Trimmer 0.25-1.5pF	26875-141
C35 †	Cer 2.2pF ±0.25pF 750V	26324-011
C36	Elec 33µF 5% 20V	26186-589
L1	40µH	44257-212
L2	910µH	44268-606
L3	430µH	44266-604
L4	430µH	44266-604
L5	40µH	44257-212
L6	40µH	44257-212
L7	910µH	44268-606
L8	650µH	44266-605
L9	650µH	44266-605
L10	40µH	44257-212
L11	2.5µH includes R10	44245-206

Circuit reference	Description	M.I. code
L13	Tuning	part of TM 8855
MR1	1S44	28357-548
MR2	PC132	28381-480
R1	Met ox 4.7kΩ 7% TE ½W	24552-100
R2	Met ox 2kΩ 7% TE ½W	24552-087
R3	Met ox 2kΩ 7% TE ½W	24552-087
R4	Carb 27Ω 10% 1/10W	24341-231
R5	Carb 3.3kΩ 10% 1/10W	24341-294
R6	Carb 3.3kΩ 10% 1/10W	24341-294
R7	Carb 27Ω 10% 1/10W	24341-231
R8	Met ox 68Ω 7% TE ½W	24552-043
R9	Carb 68Ω 10% 1/10W	24341-243
R10	2.2kΩ 10% ½W part of L11	-
RV2	Special 100kΩ	44368-006
SKTA	12 pole edge connector	23435-051
SKTB	Elbow socket TNC	23444-773
VT1	BFY90	28452-157
VT2	BFY90	28452-157

Unit (22) TM 8857 215-500 MHz Oscillator Board

When ordering, prefix circuit reference with 22

C3	Cer 0.001µF +40-20% 500V	26383-242
C4	Printed 1pF	31817-603
C5	Printed 1pF	31817-603
L2	4µH	44221-407
L3	4µH	44221-407
R1	Carb 33Ω 5% 1/10W	24331-233
R2	Carb 33Ω 5% 1/10W	24331-233
R3	Met ox 2.7kΩ 7% TE ½W	24552-092
R4	Met ox 1.8kΩ 7% TE ½W	24552-086
R5	Met ox 390Ω 7% TE ½W	24552-065
R6	Met ox 390Ω 7% TE ½W	24552-065

For symbols and abbreviations see introductions to this chapter

Unit (23) TM 8858 215-500 MHz Leveller and Carrier Filter

When ordering, prefix circuit reference with 23

Circuit reference	Description	M.I. code
C1	Special 180pF	31881-105
C2	Printed 3.09pF	-
C3	Printed 3.58pF	-
L1	0.00675μH	44111-802
L2	0.0167μH	
L3	0.0036μH	
L4	Pick up loop	44581-243
TH1	U52AD	25683-091
TH2	U52AD	25683-091

Unit (24) TM 8902 215-500 MHz Tracking

When ordering, prefix circuit reference with 24

C1 †	Plas 560pF 2% 500V	26516-430
R1 †	Met ox 220Ω 7% TE 1/2W	24552-058
R2	Met ox 68Ω 7% TE 1/2W	24552-043
R3	Met ox 68Ω 7% TE 1/2W	24552-043
R4	Met ox 68Ω 7% TE 1/2W	24552-043
R5	Met ox 68Ω 7% TE 1/2W	24552-043
R6	Met ox 68Ω 7% TE 1/2W	24552-043
R7	Met ox 68Ω 7% TE 1/2W	24552-043
R8	Met ox 68Ω 7% TE 1/2W	24552-043
R9	Met ox 68Ω 7% TE 1/2W	24552-043
R10	Met ox 68Ω 7% TE 1/2W	24552-043
R11	Met ox 68Ω 7% TE 1/2W	24552-043
R12	Met ox 68Ω 7% TE 1/2W	24552-043
R13	Met ox 68Ω 7% TE 1/2W	24552-043
R14	Met ox 68Ω 7% TE 1/2W	24552-043
R15	Met ox 68Ω 7% TE 1/2W	24552-043
R16	Met ox 68Ω 7% TE 1/2W	24552-043
R17 †	Met ox 680Ω 7% TE 1/2W	24552-076
R18 †	Met ox 35kΩ 7% TE 1/2W	24552-122
RV1	Carb 10kΩ 20% 1/4W	25611-025
RV3	Carb 470Ω 20% 1/4W	25611-010

Unit (25) TM 8845 440-1000 MHz Oscillator

When ordering, prefix circuit reference with 25

Circuit reference	Description	M.I. code
C1	Cer 0.0047μF +80-20% 500V	26373-665
C2	Cer 56pF 20% 500V	26373-855
C3	Cer 56pF 20% 500V	26373-855
C4	Cer 56pF 20% 500V	26373-855
C5	Cer 0.0047μF +80-20% 500V	26373-665
C6	Cer 10pF ±0.25pF 750V	26324-709
C7	Cer 10pF ±0.25pF 750V	26324-709
C8	Cer 47pF 2% 750V	26324-833
C9	Cer 27pF 5% 750V	26324-812
C10	Cer 27pF 5% 750V	26324-812
C11	Cer 0.0047μF +80-20% 500V	26373-665
C12	Cer 56pF 20% 500V	26373-855
C13	Cer 56pF 20% 500V	26373-855
C14	Cer 56pF 20% 500V	26373-855
C15	Cer 0.0047μF +80-20% 500V	26373-665
C16	Plas 180pF 2% 500V	26516-308
C17	Plas 180pF 2% 500V	26516-308
C18	Cer 0.0047μF +80-20% 500V	26373-665
C19	Cer 56pF 20% 500V	26373-855
C20	Cer 56pF 20% 500V	26373-855
C21	Cer 56pF 20% 500V	26373-855
C22	Cer 0.0047μF +80-20% 500V	26373-665
C23	Special 70pF	31881-103
C24	Special 70pF	31881-103
C25	Printed 3.5pF	-
C26	Printed 4pF	-
C27	Special 12pF	part of TM 8859
C28	Cer 0.0047μF +80-20% 500V	26373-665
C29	Plunger	part of TM 8859
C30	Tuning 0.5-6pF	
C31	Cer 1pF ±0.25pF 750V	26324-005
C32 †	Cer 1.5pF ±0.25pF 750V	26324-008
L1	40μH	44257-212
L2	910μH	44268-606
L3	430μH	44266-604
L4	430μH	44266-604

For symbols and abbreviations see introduction to this chapter

When ordering, prefix circuit reference with 25

Circuit reference	Description	M.I. code
L5	40 μ H	44257-212
L6	40 μ H	44257-212
L7	910 μ H	44258-506
L8	650 μ H	44256-505
L9	650 μ H	44256-505
L10	40 μ H	44257-212
L11	4 μ H	44223-801
L12	4 μ H	44223-801
L15	Resistive coil 120 Ω	44252-828
L16	Tuning part of TM 8859	
MR1	1S44	28357-548
MR2	PC141	28381-474
R1	Met ox 4.7k Ω 7% TE $\frac{1}{2}$ W	24552-100
R2	Met ox 2k Ω 7% TE $\frac{1}{2}$ W	24552-087
R3	Met ox 2k Ω 7% TE $\frac{1}{2}$ W	24552-087
R4	Carb 10 Ω 10% 1/10W	24341-220
R5	2.2M Ω 10% $\frac{1}{2}$ W part of L15	-
R6	Carb 5.6k Ω 10% 1/10W	24341-303
R7	Carb 5.6k Ω 10% 1/10W	24341-303
R8	Carb 10 Ω 10% 1/10W	24341-220
R9	Carb 5.6k Ω 10% 1/10W	24341-303
R10	Carb 5.6k Ω 10% 1/10W	24341-303
RV2	Special 100k Ω	44368-006
SKTA	12 pole edge connector	23435-051
SKTB	Elbow socket TNC	23444-773
VT1	2N2857	28452-147
VT2	2N2857	28452-147

Unit (26) TM 8861 440-1000 MHz Oscillator Board

When ordering, prefix circuit reference with 26

C1	Cer 0.001 μ F +80-20% 350V	26387-113
L1	4 μ H	44221-407
L2	4 μ H	44221-407

When ordering, prefix circuit reference with 26

Circuit reference	Description	M.I. code
R1	Met ox 5.1k Ω 7% TE $\frac{1}{2}$ W	24552-101
R2	Met ox 1.5k Ω 7% TE $\frac{1}{2}$ W	24552-084
R3	Met ox 270 Ω 7% TE $\frac{1}{2}$ W	24552-061
R4	Met ox 270 Ω 7% TE $\frac{1}{2}$ W	24552-061

Unit (27) TM 8862 440-1000 MHz Leveller and Carrier Filter

When ordering, prefix circuit reference with 27

C1	Special 180pF	31881-105
C2	Printed 1.51pF	-
C3	Printed 1.25pF	-
L1	Printed 0.0037 μ H	-
L2	Printed 0.0067 μ H	-
L3	Printed 0.0065 μ H	-
L4	Pick up loop	44681-244
TH1	U52AD	25683-091
TH2	U52AD For Service Manuals Contact MAURITRON TECHNICAL SERVICES 8 Cherry Tree Rd, Chinnor Oxon OX9 4QY Tel: 01844-351894 Fax: 01844-352554 Email: enquiries@mauritron.co.uk	25683-091

Unit (28) TM 8903 440-1000 MHz Tracking

When ordering, prefix circuit reference with 28

C1 †	Plas 330pF 2% 500V	26516-374
R1 †	Met ox 910 Ω 7% TE $\frac{1}{2}$ W	24552-079
R2	Met ox 4.7 Ω 7% TE $\frac{1}{2}$ W	24552-037
R3	Met ox 4.7 Ω 7% TE $\frac{1}{2}$ W	24552-037
R4	Met ox 4.7 Ω 7% TE $\frac{1}{2}$ W	24552-037
R5	Met ox 4.7 Ω 7% TE $\frac{1}{2}$ W	24552-037
R6	Met ox 4.7 Ω 7% TE $\frac{1}{2}$ W	24552-037
R7	Met ox 4.7 Ω 7% TE $\frac{1}{2}$ W	24552-037
R8	Met ox 4.7 Ω 7% TE $\frac{1}{2}$ W	24552-037
R9	Met ox 4.7 Ω 7% TE $\frac{1}{2}$ W	24552-037

When ordering, prefix circuit reference with 28

When ordering, prefix circuit reference with 29

Circuit reference	Description	M.I. code
R10	Met ox 4.7Ω 7% TE ½W	24552-037
R11	Met ox 4.7Ω 7% TE ½W	24552-037
R12	Met ox 4.7Ω 7% TE ½W	24552-037
R13	Met ox 4.7Ω 7% TE ½W	24552-037
R14	Met ox 4.7Ω 7% TE ½W	24552-037
R15	Met ox 4.7Ω 7% TE ½W	24552-037
R16	Met ox 4.7Ω 7% TE ½W	24552-037
R17 †	Met ox 820Ω 7% TE ½W	24552-078
R18 †	Met ox 15kΩ 7% TE ½W	24552-114
RV1	Carb 10kΩ 20% ½W	25611-025
RV3	Carb 470Ω 20% ½W	25611-010

Circuit reference	Description	M.I. code
L3	2.3mH	44272-601
L4	2.3mH	44272-601
L5	2.3mH	44272-601
L6	2.3mH	44272-601
L7	2.3mH	44272-601
L8	2.3mH	44272-601
L11	4.7μH	23642-553
L12	2.3mH	44272-601
MR1	Silicon mixer	28348-135
MR2	Silicon mixer	28348-135

Unit (29) TM 8877 Coaxial Switch and Carrier Level Monitor

When ordering, prefix circuit reference with 29

C1	Cer 0.0047μF +80-20% 500V	26373-665
C2	Cer 0.0047μF +80-20% 500V	26373-665
C3	Cer 0.01μF +80-20% 100V	26383-055
C4	Cer 200pF 20% 500V	26333-568
C5	Cer 0.0047μF +80-20% 500V	26373-665
C6	Cer 0.001μF +80-20% 350V	26387-113
C7	Special 200pF	31881-102
C8	Special 200pF	31881-102
C9	Cer 200pF 20% 500V	26333-568
C10	Cer 0.0047μF +80-20% 500V	26373-665
C11	Cer 0.0047μF +80-20% 500V	26373-665
C12	Cer 0.0047μF +80-20% 500V	26373-665
C13	Cer 0.001μF +80-20% 350V	26387-113
C14	Cer 0.0047μF +80-20% 500V	26373-665
C15	Cer 0.0047μF +80-20% 500V	26373-665
C16	Cer 0.0047μF +80-20% 500V	26373-665
C17	Cer 0.0047μF +80-20% 500V	26373-665
C18	Cer 0.001μF +80-20% 300V	26373-733
C19	Cer 0.0047μF 20% 500V	26373-793
L1	28μH	44253-209
L2	30μH	44257-403

R1	Met ox 150Ω 5% TE ½W	24511-554
R2	Met ox 50Ω 5% TE ½W	24511-538
R3	Carb 2.2kΩ 10% 1/10W	24341-288
R4	Carb 2.2kΩ 10% 1/10W	24341-288
R5	Carb 2.2kΩ 10% 1/10W	24341-288
R6	Carb 100Ω 10% 1/10W	24341-250
R7	Carb 150Ω 10% 1/10W	24341-254
R8	Carb 47Ω 10% 1/10W	24341-237
R9	Carb 470Ω 10% 1/10W	24341-269
R10	Carb 100Ω 10% 1/10W	24341-250
R11	Carb 22Ω 10% 1/10W	24341-228
SA	R.F. range	-
SB	Signal monitor director	-
SKTA	Panel socket TNC	23444-813
SKTB	Panel socket TNC	23444-813
SKTC	Panel socket TNC	23444-813
SKTD	Panel socket TNC	23444-813
SKTE	Panel socket TNC	23444-813
SKTF	Panel socket TNC	23444-813
SKTG	Panel socket TNC	23444-813
TH1	CZ3	25683-644
VT1	BFY90	28452-157
VT2	BFY90	28452-157

For symbols and abbreviations see introduction to this chapter

Unit 30 TM 8070/1 Coarse Attenuator

As the calibration techniques are complex attenuator parts are listed for information only; we do not supply the components as separate items.

Circuit reference	Description	M.I. code
R1	Met 53.3Ω 0.5% 1/2W	
R2	Met 790Ω 0.5% 1/2W	
R3	Met 53.3Ω 0.5% 1/2W	
R4	Met 53.3Ω 0.5% 1/2W	
R5	Met 790Ω 0.5% 1/2W	
R6	Met 53.3Ω 0.5% 1/2W	
R7	Met 61Ω 0.5% 1/2W	
R8	Met 24.7Ω 0.5% 1/2W	
R9	Met 61Ω 0.5% 1/2W	
R10	Met 61Ω 0.5% 1/2W	
R11	Met 24.7Ω 0.5% 1/2W	
R12	Met 61Ω 0.5% 1/2W	
R13	Met 61Ω 0.5% 1/2W	
R14	Met 24.7Ω 0.5% 1/2W	
R15	Met 61Ω 0.5% 1/2W	

SA to SK Micro switch

SKTA Type N
SKTB Type N

Unit 31 TM 8071/1 Fine Attenuator

As the calibration techniques are complex the attenuator parts are listed for information only; we do not supply the components as separate items.

R1	Met 150Ω 1% 1/2W
R2	Met 37.3Ω 1% 1/2W
R3	Met 150Ω 1% 1/2W
R4	Met 292Ω 1% 1/2W
R5	Met 17.6Ω 1% 1/2W
R6	Met 292Ω 1% 1/2W
R7	Met 870Ω 1% 1/2W
R8	Met 5.77Ω 1% 1/2W

Circuit reference	Description	M.I. code
R9	Met 870Ω 1% 1/2W	
R10	Met 436Ω 1% 1/2W	
R11	Met 11.6Ω 1% 1/2W	
R12	Met 436Ω 1% 1/2W	
R13	Met 96.3Ω 1% 1/2W	
R14	Met 71.2Ω 1% 1/2W	
R15	Met 96.3Ω 1% 1/2W	

SA to SK Micro switch

SKTA Type N
SKTB Type N

For Service Manuals Contact
MAURITRON TECHNICAL SERVICES
8 Cherry Tree Rd, Chinnor
Oxon OX9 4QY
Tel: 01844-351694 Fax: 01844-352554
Email: enquiries@mauritron.co.uk

Unit 32 TM 8879 Crystal Calibrator

When ordering, prefix circuit reference with 32

C1	Cer ϕ 0.0047μF min 350V	26373-665
C2	Cer ϕ 0.0047μF min 350V	26373-665
C3	Cer ϕ 0.0047μF min 350V	26373-665
C4	Cer ϕ 0.0047μF min 350V	26373-665
C5	Cer ϕ 0.0047μF min 350V	26373-665
C6	Cer ϕ 56pF 20% 350V	26373-855
C7	Plas 453pF 1% 500V	26516-403
C8	not used	
C9	not used	
C10	Plas 549pF 1% 500V	26516-421
C11	Cer ϕ 0.0047μF min 350V	26373-665
C12	Cer ϕ 0.0047μF min 350V	26373-665
C13	Cer ϕ 0.0047μF min 350V	26373-665
C14	Cer ϕ 0.0047μF min 350V	26373-665
C15	Cer ϕ 0.0047μF min 350V	26373-665
C16	Cer ϕ 56pF 20% 350V	26373-855
C17	Plas 267pF 1% 500V	26516-347
C18	Cer ϕ 0.0047μF min 350V	26373-665
C19	Cer ϕ 0.0047μF min 350V	26373-665
C20	Cer ϕ 0.0047μF min 350V	26373-665
C21	Cer ϕ 0.0047μF min 350V	26373-665
C22	Cer ϕ 0.0047μF min 350V	26373-665
C23	Cer ϕ 56pF 20% 350V	26373-855

For symbols and abbreviations see introduction to this chapter

When ordering, prefix circuit reference with 32

When ordering, prefix circuit reference with 33

Circuit reference	Description	M.I. code
L1	4 μ H	44223-801
L2	47.4mH	44271-415
L3	4 μ H	44223-801
L4	4 μ H	44223-801
L5	43.2mH	44271-416
PLA	8 way includes tape	43122-703
SKTA	Bulkhead socket	23444-714
X1	10MHz, Q01670B 50/53/30	28311-772

Circuit reference	Description	M.I. code
C25	Cer 0.1 μ F +50-25% 30V	26383-031
C26	Var Cer 10pF/40pF	26847-265
C27	Plas 30pF \pm 2pF 500V	26516-119
C28	Cer 2.2pF \pm 0.25pF 750V	26324-011
L1	5.5 μ H	44247-203
L2	25 μ H	44262-825
L3	25 μ H	44262-825
L4	25 μ H	44262-825
L5	11 μ H	44253-407
L6	4 μ H	44221-407
L7	1.8mH	44268-608
L8	1.8mH	44268-608
L9	5.5 μ H	44247-203
L10	25 μ H	44262-825
L11	1.8mH	44268-608

Unit **33** TM 8880 Standard Frequency Generator

When ordering, prefix circuit reference with 33

C1	Plas 30pF \pm 2pF 500V	26516-119
C2	Var air 2.5pF/13.4pF	26817-238
C3	Cer 2.2pF \pm 0.25pF 750V	26324-011
C4	Plas 50pF \pm 2pF 500V	26516-172
C5	Plas 100pF 2% 500V	26516-246
C6	Cer 4.7pF \pm 0.25pF 750V	26324-017
C7	Plas 20pF \pm 1pF 500V	26516-078
C8	Var Cer 10pF/40pF	26847-265
C9	Cer 0.01 μ F +80-20% 100V	26383-055
C10	Plas 270pF 2% 500V	26516-352
C11	Plas 60pF \pm 2pF 500V	26516-189
C12	Cer 0.01 μ F +80-20% 100V	26383-055
C13	Plas 20pF \pm 1pF 500V	26516-078
C14	Cer 0.1 μ F +50-25% 30V	26383-031
C15	Var air 2.5pF/13.4pF	26817-238
C16	Plas 80pF \pm 2pF 500V	26516-219
C17	Var Cer 10pF/40pF	26847-265
C18	Plas 60pF \pm 2pF 500V	26516-189
C19	Cer 6.8pF \pm 0.25pF 750V	26324-706
C20	Cer 0.1 μ F +50-25% 30V	26383-031
C21	Plas 620pF 2% 500V	26516-435
C22	Cer 47pF 2% 750V	26324-833
C23	Cer 0.1 μ F +50-25% 30V	26383-031
C24	Cer 0.01 μ F +80-20% 100V	26383-055

MR1	1N916	28336-466
MR2	1N916	28336-466
MR3	1N916	28336-466
MR4	1N916	28336-466
MR5	1N916	28336-466
MR6	1N916	28336-466
R1	Met ox 16k Ω 7% TE $\frac{1}{2}$ W	24552-115
R2	Met ox 3.9k Ω 7% TE $\frac{1}{2}$ W	24552-096
R3	Met ox 2k Ω 7% TE $\frac{1}{2}$ W	24552-087
R4	Met ox 47 Ω 7% TE $\frac{1}{2}$ W	24552-037
R5	Met ox 560 Ω 7% TE $\frac{1}{2}$ W	24552-072
R6	Met ox 220 Ω 7% TE $\frac{1}{2}$ W	24552-058
R7	Met ox 100 Ω 7% TE $\frac{1}{2}$ W	24552-050
R8	Met ox 100 Ω 7% TE $\frac{1}{2}$ W	24552-050
R9	Met ox 470 Ω 7% TE $\frac{1}{2}$ W	24552-069
R10	Met ox 3.9k Ω 7% TE $\frac{1}{2}$ W	24552-096
R11 †	Carb 4.7k Ω 10% 1/10W	24341-300
R12	Met ox 220 Ω 7% TE $\frac{1}{2}$ W	24552-058
R13	Met ox 100 Ω 7% TE $\frac{1}{2}$ W	24552-050
R14	Met ox 100 Ω 7% TE $\frac{1}{2}$ W	24552-050

For symbols and abbreviations see introduction to this chapter

When ordering, prefix circuit reference with 33

Circuit reference	Description	M.I. code
R15	Met ox 4.70kΩ 7% TE ½W	24552-069
R16	Met ox 3.9kΩ 7% TE ½W	24552-096
R17 †	Met ox 1kΩ 7% TE ½W	24552-080
R18	Met ox 2.2kΩ 7% TE ½W	24552-088
R19	Met ox 680Ω 7% TE ½W	24552-076
R20	Met ox 4.70kΩ 7% TE ½W	24552-069
R21	Met ox 82kΩ 5% ½W	24511-633
VT1	MM1613	28454-776
VT2	MM1613	28454-776
VT3	2N3663	28451-692
VT4	2N3576	28432-318
VT5	2N3663	28451-692
VT6	2N3663	28451-692
VT7	2N3576	28432-318
VT8	2N3663	28451-692
VT9	MM1613	28454-776

For Service Manuals Contact
MAURITRON TECHNICAL SERVICES
8 Cherry Tree Rd, Chinnor
Oxon OX9 4QY
Tel: 01844-351694 Fax: 01844-352554
Email: enquiries@mauratron.co.uk

Unit **34** TM 8881 Amplifier and Mixer

When ordering, prefix circuit reference with 34

C1	Special 200pF	31881-102
C2	Cer 2.2pF ±0.25pF 750V	26324-011
C3	Special 50pF (4 x 200pF in series)	31881-102
C4	Plas 150pF 2% 500V	26516-291
C5	Plas 0.68μF 10% 250V	26512-272
C6	Elec 50μF +100-20% 25V	26423-317
C7	Elec 12μF +100-20% 50V	26423-309
C8	Elec 4μF +100-20% 50V	26423-305
C9	Elec 50μF +100-20% 25V	26423-317
C10	Elec 12μF +100-20% 50V	26423-309
C11	Elec 4μF +100-20% 50V	26423-305
C12	Elec 12μF +100-20% 50V	26423-309
C13	Elec 12μF +100-20% 50V	26423-309
C14	Elec 12μF +100-20% 50V	26423-309
C15	Elec 12μF +100-20% 50V	26423-309
C16	Elec 4μF +100-20% 50V	26423-305
C17	Elec 4μF +100-20% 50V	26423-305
C18	Elec 50μF +100-20% 25V	26423-317

When ordering, prefix circuit reference with 34

Circuit reference	Description	M.I. code
C19	Elec 12μF +100-20% 50V	26423-309
C20	Plas 560pF 2% 125V	26516-423
C21	Cer 0.1μF +50-25% 30V	26383-031
L1	11μH	44253-407
L2	2.3mH	44272-601
MR1	HPA0112	28335-681
MR2	1N416C	28348-135
MR3	1N416C	28348-135
MR4	1S44	28357-548
MR5	1S44	28357-548
MR6	1S44	28357-548
MR7	1S44	28357-548
R1	Carb 22Ω 10% 1/10W	24341-228
R2	Carb 56Ω 10% 1/10W	24341-240
R3 †	Carb 56Ω 10% 1/10W	24341-240
R4 †	Carb 270Ω 10% 1/10W	24341-261
R5	Carb 56Ω 10% 1/10W	24341-240
R6	Met ox 390Ω 7% TE ½W	24552-065
R7	Met ox 390Ω 7% TE ½W	24552-065
R8	Met ox 75Ω 7% TE ½W	24552-044
R9	Met ox 2.2kΩ 7% TE ½W	24552-088
R10	Met ox 100kΩ 7% TE ½W	24552-135
R11	Met ox 2.2kΩ 7% TE ½W	24552-088
R12	Met ox 1.5kΩ 7% TE ½W	24552-084
R13	Met ox 4.7kΩ 7% TE ½W	24552-100
R14	Met ox 75Ω 7% TE ½W	24552-044
R15	Met ox 2.2kΩ 7% TE ½W	24552-088
R16	Met ox 100kΩ 7% TE ½W	24552-135
R17	Met ox 2.2kΩ 7% TE ½W	24552-088
R18	Met ox 1.5kΩ 7% TE ½W	24552-084
R19	Met ox 4.7kΩ 7% TE ½W	24552-100
R20	Met ox 2.2kΩ 7% TE ½W	24552-088
R21	Met ox 100kΩ 7% TE ½W	24552-135
R22	Met ox 2.2kΩ 7% TE ½W	24552-088
R23	Met ox 4.70kΩ 7% TE ½W	24552-069
R24	Met ox 1kΩ 7% TE ½W	24552-080

For symbols and abbreviations see introduction to this chapter

When ordering, prefix circuit reference with 34

Circuit reference	Description	M.I. code
R25	Met ox 4.7kΩ 7% TE ½W	24552-100
R26	Met ox 100Ω 7% TE ½W	24552-050
R27	Met ox 100Ω 7% TE ½W	24552-050
R28	Carb 4.7kΩ 10% 1/10W	24341-300
R29	Met ox 10kΩ 7% TE ½W	24552-110
R30	Carb 4.70kΩ 10% ½W	24342-152
R31	Met ox 1kΩ 7% TE ½W	24552-080
R32	Met ox 3.9kΩ 7% TE ½W	24552-096
R33	Met ox 82kΩ 7% TE ½W	24552-133
R34	Met ox 6.2kΩ 7% TE ½W	24552-104
R35	Met ox 4.7Ω 7% TE ½W	24552-037
R36	Met ox 20kΩ 7% TE ½W	24552-117
R37	Met ox 4.7kΩ 7% TE ½W	24552-126
R38	Met ox 18kΩ 7% TE ½W	24552-116
R39	Met ox 10kΩ 7% TE ½W	24552-110
R40	Met ox 10kΩ 7% TE ½W	24552-110
R41	Met ox 10kΩ 7% TE ½W	24552-110
R42	Met ox 430Ω 7% TE ½W	24552-067
R43	Met ox 10kΩ 7% TE ½W	24552-110
RV1	Carb 100kΩ 20% ¼W	25611-038
T1	Special	43541-009
T2	Special	31827+101
TR1	CZ3	25683-644
VT1	BC108	28452-787
VT2	BC108	28452-787
VT3	BC108	28452-787
VT4	BC108	28452-787
VT5	BC108	28452-787
VT6	BC108	28452-787
VT7	BC108	28452-787
VT8	BC108	28452-787
VT9	BCY72	28433-487
VT10	BCY72	28433-487

Unit 35 TM 8882 Filters Section 'A'

When ordering, prefix circuit reference with 35

Circuit reference	Description	M.I. code
C1	Var Cer 10pF/40pF	26847-265
C2	Plas 40pF ±2pF 500V	26516-151
L1	40μH	44257-212
L2	40μH	44257-212
L3	40μH	44257-212
L4	40μH	44257-212
L5	40μH	44257-212

Unit 36 TM 8883 Filters Section 'B'

When ordering, prefix circuit reference with 36

L1	40μH	44257-212
L2	40μH	44257-212
L3	40μH	44257-212
L4	40μH	44257-212
L5	40μH	44257-212
L6	4μH	44221-407

Unit 37 TM 8885 Power Supply (excluding board)

When ordering, prefix circuit reference with 37

C1	Elec 2500μF +50-20% 50V	26427-134
C2	Elec 2500μF +50-20% 50V	26427-134
FS1	160mA 250V	23411-003
FS2	1A 250V	23411-006
MR1	1N540	28357-048
PLA	3 pin mains	23423-151
R1	WW 6.5Ω 5% 9W	25126-515
R2	Carb 15Ω 10% 1W*	24343-024
SA	Supply	44321-406
SB	Supply voltage selector	23467-119
SC	Supply selector	44322-418

For symbols and abbreviations see introduction to this chapter

When ordering, prefix circuit reference with 37

When ordering, prefix circuit reference with 38

Circuit reference	Description	M.I. code
T1	Mains	43453-010
TP1	DC+	23235-177
TP2	DC-	23235-176
TP3	Mod. osc. sync output - insulated	23235-176
TP4	Mod. osc. sync output - earth	23235-177
VT1	2N1553	28424-886

Circuit reference	Description	M.I. code
RV2	50k Ω 20%	part of 38SB
RV3	1k Ω 20%	part of 38SA
RV4a	WW 16k Ω /16k Ω 2%	25874-578
RV4b		
RV5	5k Ω 20%	part of 38SC
RV6	1k Ω 20%	part of 38SD
RV7	250k Ω 20%	part of 38SE
SA	F.M. range includes RV3	44323-319
SB	Δ F. range includes RV2	44322-130
SC	Modulation selector includes RV5	44325-027
SD	Modulation monitor and calibrator selector includes RV6	44323-320
SE	Carrier mode includes RV7	44323-318

Unit **38** TM 8866 Top Front Panel

When ordering, prefix circuit reference with 38

M1	Carrier level 50 μ A	44572-213
M2	Modulation and calibrator monitor 100 μ A	44572-214
R1	Met 9625 Ω 0.5% $\frac{1}{4}$ W	24635-402
R2	Met 6111 Ω 0.5% $\frac{1}{4}$ W	24635-202
R3	Met 5327 Ω 0.5% $\frac{1}{4}$ W	24635-201
R4	Met 7115 Ω 0.5% $\frac{1}{4}$ W	24635-301
R5	Met 24.75k Ω 0.5% $\frac{1}{4}$ W	24635-503
R6	Met 79k Ω 0.5% $\frac{1}{4}$ W	24635-602
R7	Met 5327 Ω 0.5% $\frac{1}{4}$ W	24635-201
R8	Met 6111 Ω 0.5% $\frac{1}{4}$ W	24635-202
R9	Met 9625 Ω 0.5% $\frac{1}{4}$ W	24635-402
R10	Met 9625 Ω 0.5% $\frac{1}{4}$ W	24635-402
R11	Met 6111 Ω 0.5% $\frac{1}{4}$ W	24635-202
R12	Met 24.75k Ω 0.5% $\frac{1}{4}$ W	24635-503
R13	Met 7115 Ω 0.5% $\frac{1}{4}$ W	24635-301
R14	Met 6111 Ω 0.5% $\frac{1}{4}$ W	24635-202
R15	Met 9625 Ω 0.5% $\frac{1}{4}$ W	24635-402
R16	Met ox 680 Ω 7% TE $\frac{1}{2}$ W	24552-076
R17	Carb 1.8k Ω 10% $\frac{1}{2}$ W	24342-086
R18	Carb 1.5k Ω 10% $\frac{1}{2}$ W	24342-084
R19	WW 750 Ω 5% $\frac{1}{4}$ W	25123-077
R20	Carb 1k Ω 10% $\frac{1}{2}$ W	24342-080

Unit **39** TM 8867 Top Mother Board

When ordering, prefix circuit reference with 39

C1	Elec 100 μ F +100-20% 25V	26423-327
R1	Carb 600 Ω 1% $\frac{1}{4}$ W	24133-600
R2	Met ox 100k Ω 7% TE $\frac{1}{2}$ W	24552-135
R3	Met ox 820 Ω 7% TE $\frac{1}{2}$ W	24552-078
SKTA	18 pole edge connector	23435-054
SKTB	18 pole edge connector	23435-054
SKTC	18 pole edge connector	23435-054
SKTD	18 pole edge connector	23435-054
SKTE	18 pole edge connector	23435-054
SKTF	18 pole edge connector	23435-054
SKTG	18 pole edge connector	23435-054
SKTH	18 pole edge connector	23435-054
SKTJ	18 pole edge connector	23435-054

For symbols and abbreviations see introduction to this chapter

Unit (40) TM 8875 Bottom Mother Board

When ordering, prefix circuit reference with 40

Circuit reference	Description	M.I. code
L1	10 μ H	44221-603
PLA	18 pole includes tape	43122-701
PLB	18 pole includes tape	43122-701
PLC	12 pole includes tape	43122-702
PLD	12 pole includes tape	43122-702
PLE	12 pole includes tape	43122-702
PLF	12 pole includes tape	43122-702
SA	R.F. range	44323-707
SKTA	18 pole edge connector	23435-054
SKTB	8 pole edge connector	23435-041

Unit (41) TM 9111 Bottom Front Panel

When ordering, prefix circuit reference with 41

Circuit reference	Description	M.I. code
JKA	Crystal cal. output	23421-558
TP1	Ext. mod.	23235-176
TP2	Earth	23235-177
TP3	Ext. Freq. shift	23235-176

Miscellaneous

Circuit reference	Description	M.I. code
LINK1	Osc. A - 29 SKTA	43125-063
LINK2	Osc. B - 29 SKTB	43125-065
LINK3	Osc. C - 29 SKTC	43125-066
LINK4	Osc. D - 29 SKTD	43125-067
LINK5	Direct output - 29 SKTE	43125-062
LINK6	Counter output - 29 SKTF	43125-061
LINK7	Crystal cal. - 29 SKTG	43125-064

Miscellaneous continued

Circuit reference	Description	M.I. code
LINK8	Direct output - attenuator input	23443-787
LINK9	30 SKTA - 31 SKTA	23443-787
	Fuse holder (FS1 or FS2)	23416-191
Knob	Frequency control	41146-005
Knob	Drive brake	31141-111
Knob	ΔF control and scale	44371-227
Cursor	For ΔF scale	31185-722
Knob	Modulation frequency control and scale	41143-509
Cursor	For modulation frequency scale	31185-722
Knob	ΔF range switch	41145-238
Knob	F.M. range switch	41145-238
Knob	Modulation selector	41145-238
Knob	Modulation monitor and calibrator selector	41145-238
Knob	Carrier mode selector	41145-238
Knob	Set zero control	41141-405
Knob	Set full scale control	41141-405
Knob	Set deviation control	41141-405
Knob	Calibrator output level control	41141-405
Knob	Carrier level control	41141-405
Knob	Supply selector (rear panel)	41141-207
Knob	Signal monitor director	41145-206
Knob	R.F. range switch	41145-206
Knob	Supply switch	41142-209
Knob	Fine attenuator control and scale	41143-701
Knob	Coarse attenuator control and scale	41146-003
Case	Top and sides	41651-215
Case	Bottom	41626-018
Case	Back	41635-049
	Foot	37574-109
	Retractable stand	35116-107
	Side handle	41148-022
	Panel handle	35852-111

For symbols and abbreviations see introduction to this chapter

CIRCUIT NOTES

1. COMPONENT VALUES

Resistors: No suffix = ohms, k = kilohms, M = megohms.

Capacitors: No suffix = microfarads, p = picofarads.













Inductors: No suffix = henrys, m = millihenrys, μ = microhenrys.

† value selected during test, nominal value shown.

2. VOLTAGES

Shown in italics adjacent to the point to which the measurement refers. See Sect. 5.3 for conditions.

3. SYMBOLS

-  arrow indicates clockwise rotation of knob.
-  etc., external front or rear panel marking.
-  tag on printed board.
-  other tag.
-  preset control.
-  unit identification number.
-  printed board.
-  edge connector.
-  test point.
-  conductor destination (board , tag 12).
-  conductor destination (tag 12, same board).

 on the main circuit diagrams mother boards, which are used for interconnections between units, are shaded.

These symbols are used to identify branches of the power supply circuitry but have no particular physical reality on the printed boards.



point marked with this symbol is connected to and receives power from



point marked with this symbol.

4. CIRCUIT REFERENCES

These are, in general, given in abbreviated form. See also introduction to Chap. 6.

5. SWITCHES

Rotary switches are drawn schematically.

Letters indicate control knob settings.

1F = 1st section (front panel), front.

1B = 1st section, back.

2F = 2nd section, front.

etc.

For Service Manuals Contact
MAURITRON TECHNICAL SERVICES
8 Cherry Tree Rd, Chinnor
Oxon OX9 4QY
Tel:- 01844-351694 Fax:- 01844-352554
Email:- enquiries@mauritron.co.uk

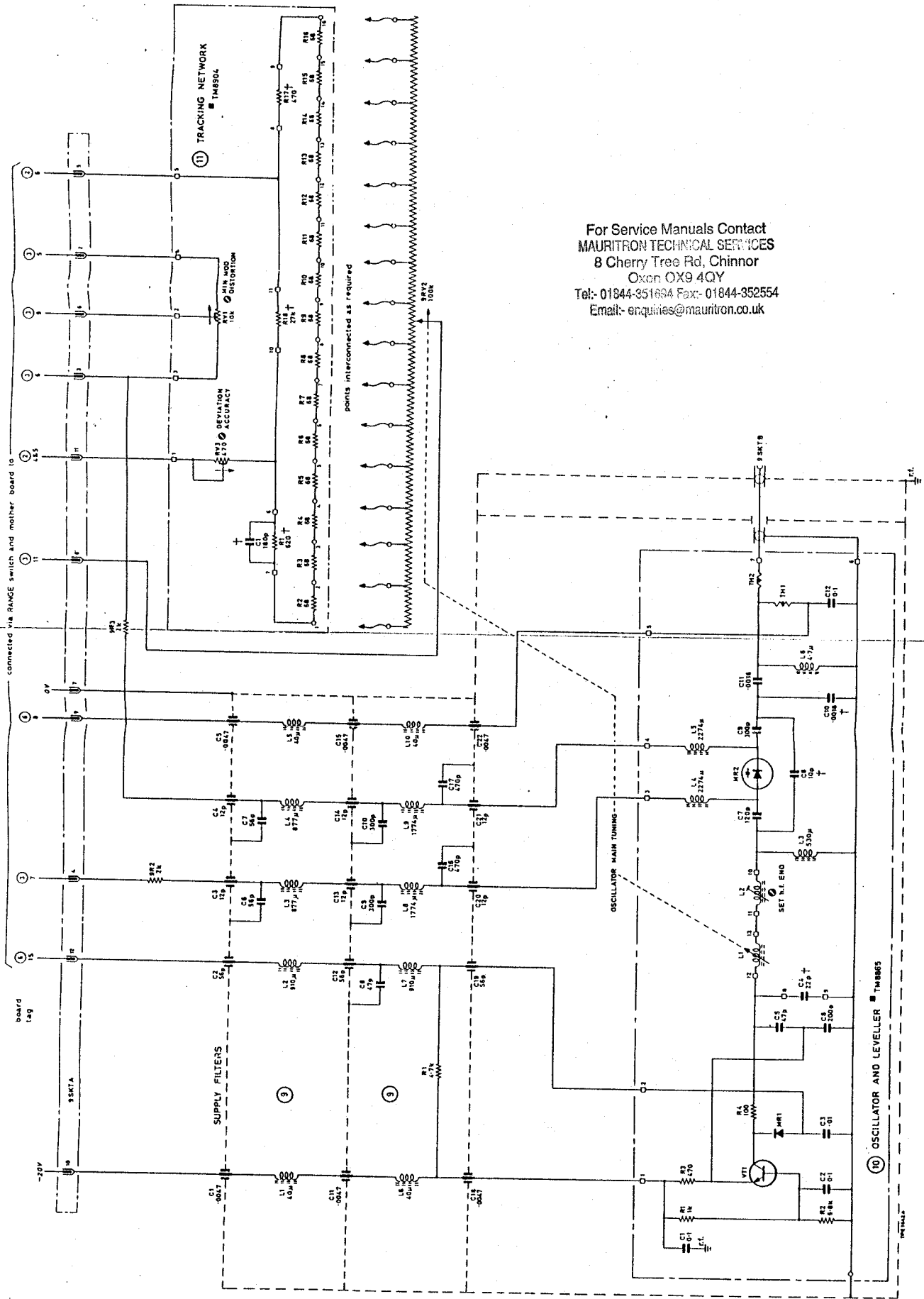

For Service Manuals Contact
MAURITRON TECHNICAL SERVICES
 8 Cherry Tree Rd, Chinnor
 Oxon OX9 4QY
 Tel:- 01844-351604 Fax:- 01844-352554
 Email:- enquiries@mauriton.co.uk

Fig. 7.1 Circuit—4 to 10 MHz oscillator

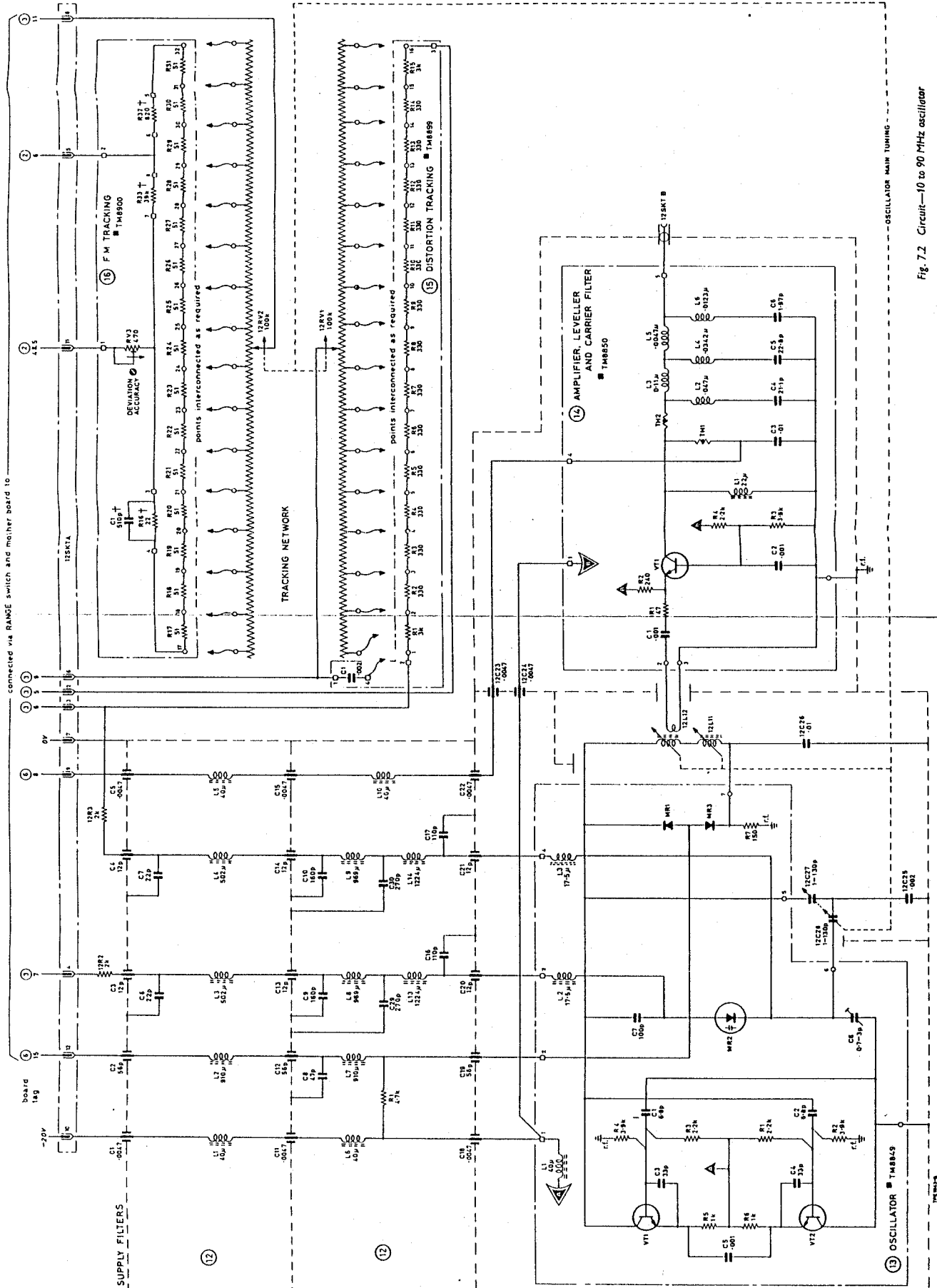

Fig. 7.2 Circuit—10 to 90 MHz oscillator

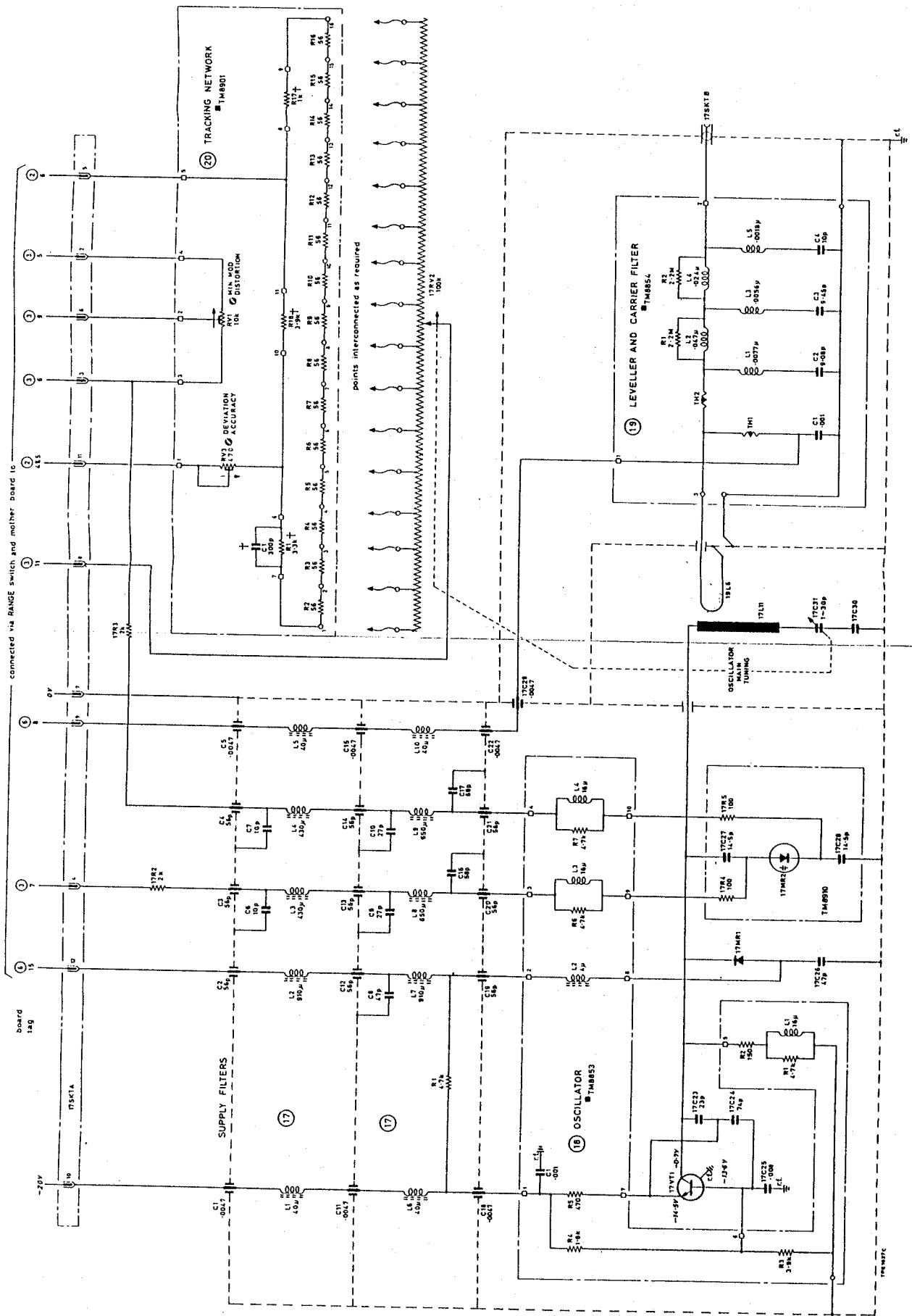

Fig. 7.3 Circuit—88 to 220 MHz oscillator

For Service Manuals Contact
MAURITRON TECHNICAL SERVICES
 8 Cherry Tree Rd, Chinnor
 Oxon OX9 4QY
 Tel: 01844-651661 Fax: 01844-352554
 Email: enquiries@mauritron.co.uk

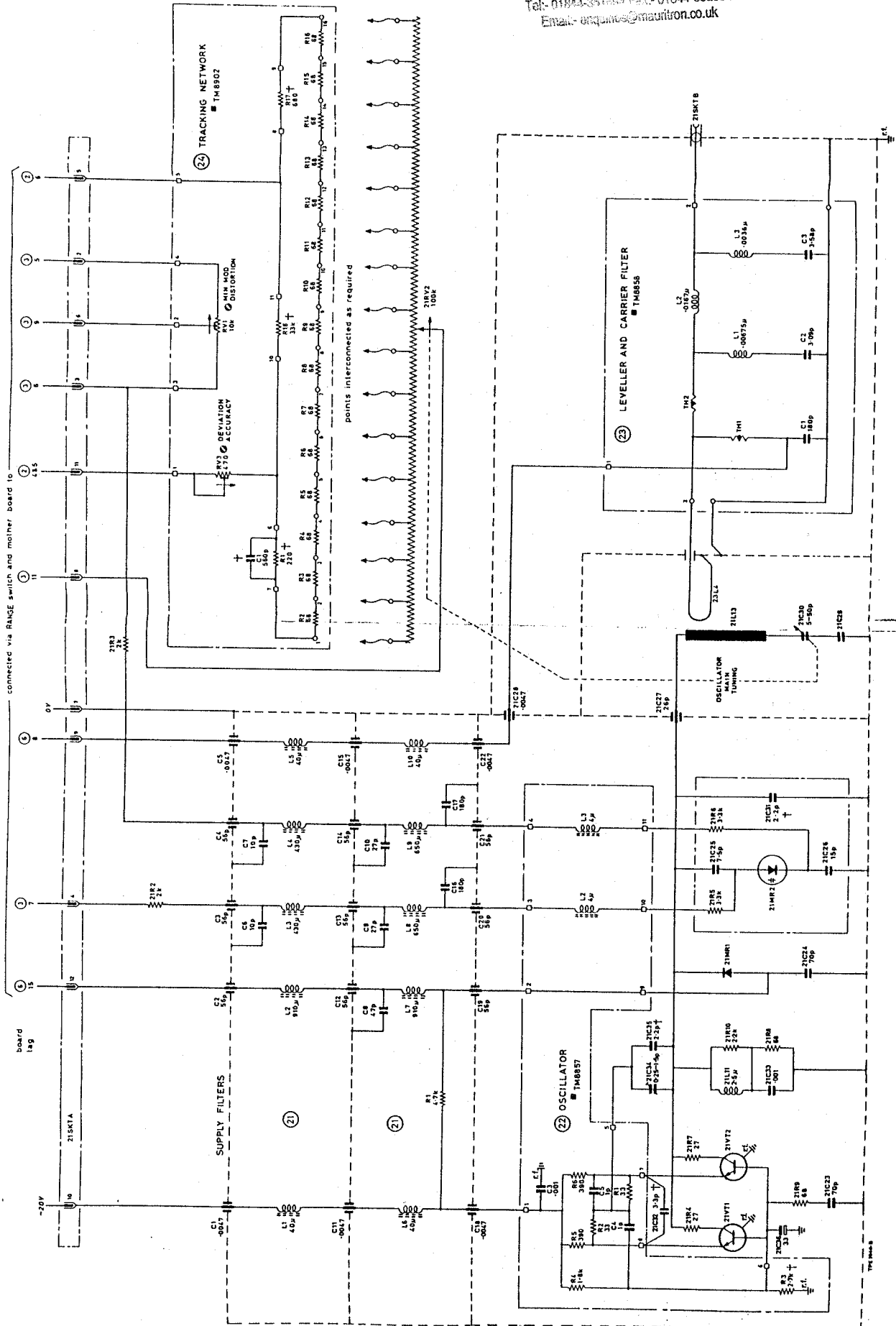

Fig. 7.4 Circuit—215 to 500 MHz oscillator

For Service Manuals Contact
MAURITRON TECHNICAL SERVICES
 8 Cherry Tree Rd, Chinnor
 Oxon OX9 4QY
 Tel: 01844-351634 Fax: 01844-352554
 Email: enquiries@mauritron.co.uk

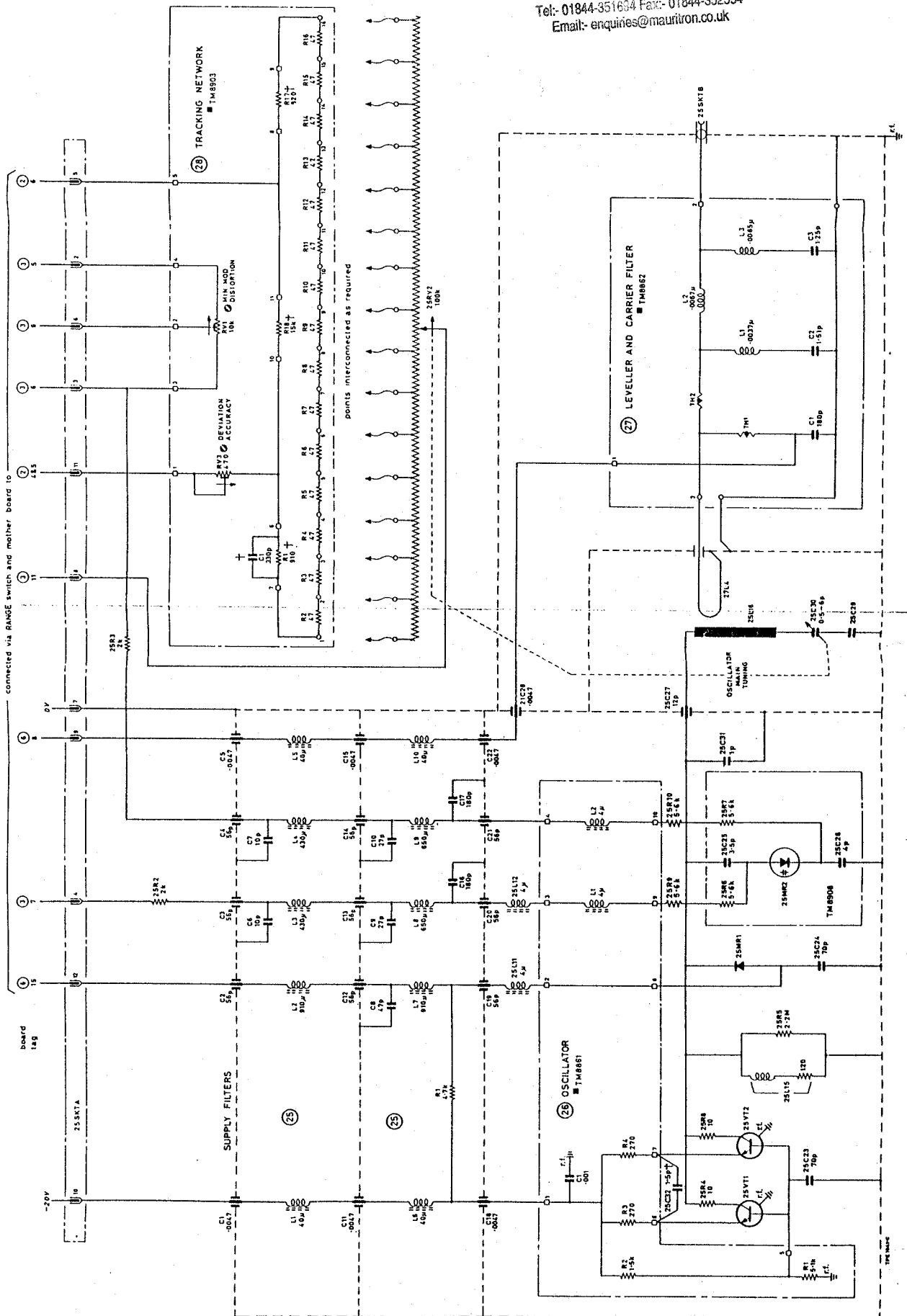
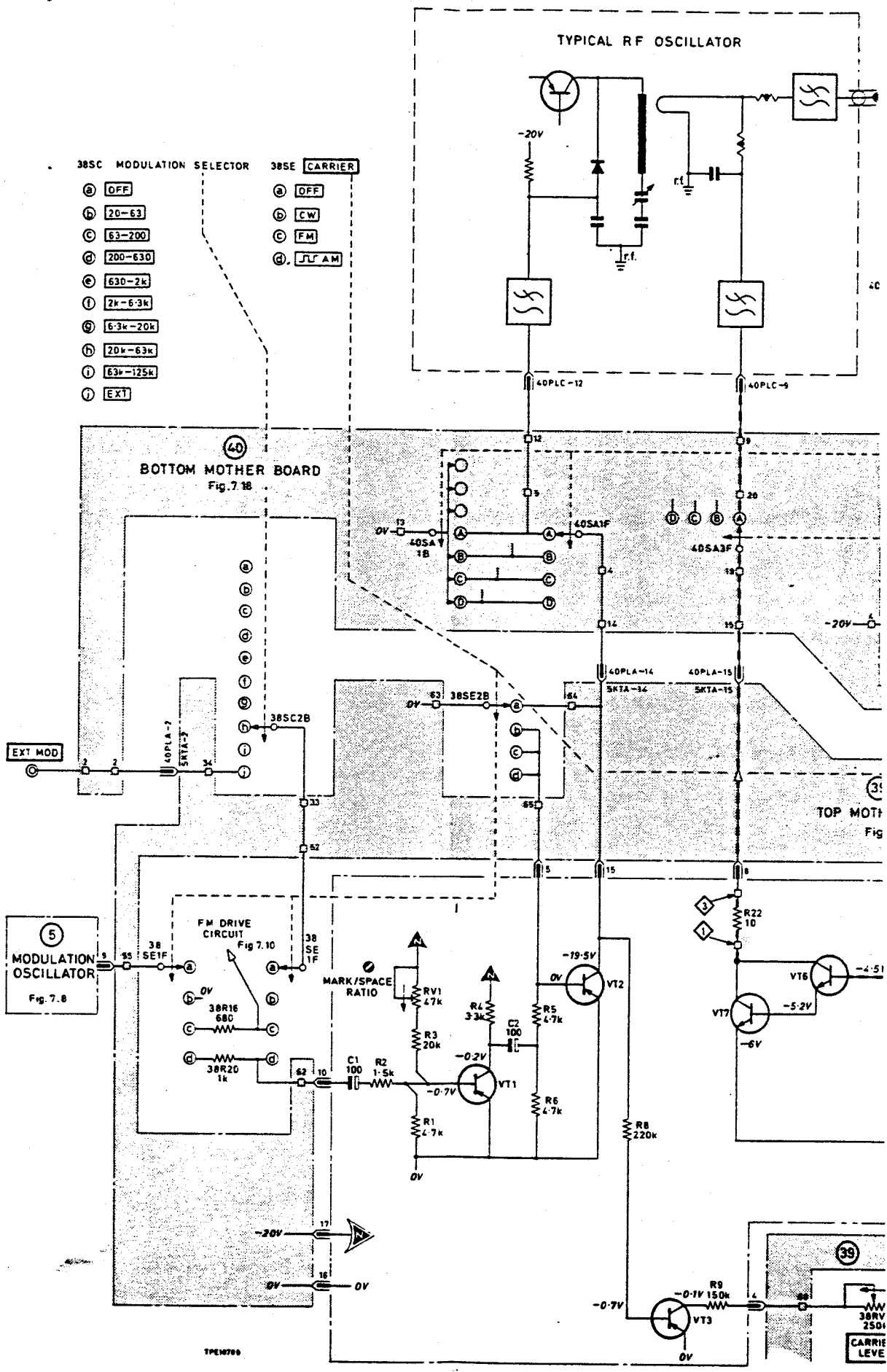

Fig. 7.5 Circuit—46 to 1000 MHz oscillator



For Service Manuals Contact
MAURITRON TECHNICAL SERVICES
 8 Cherry Tree Rd, Chinnor
 Oxon OX9 4QY
 Tel: 01844-351004 Fax: 01844-352554
 Email: enquiries@mauritron.co.uk

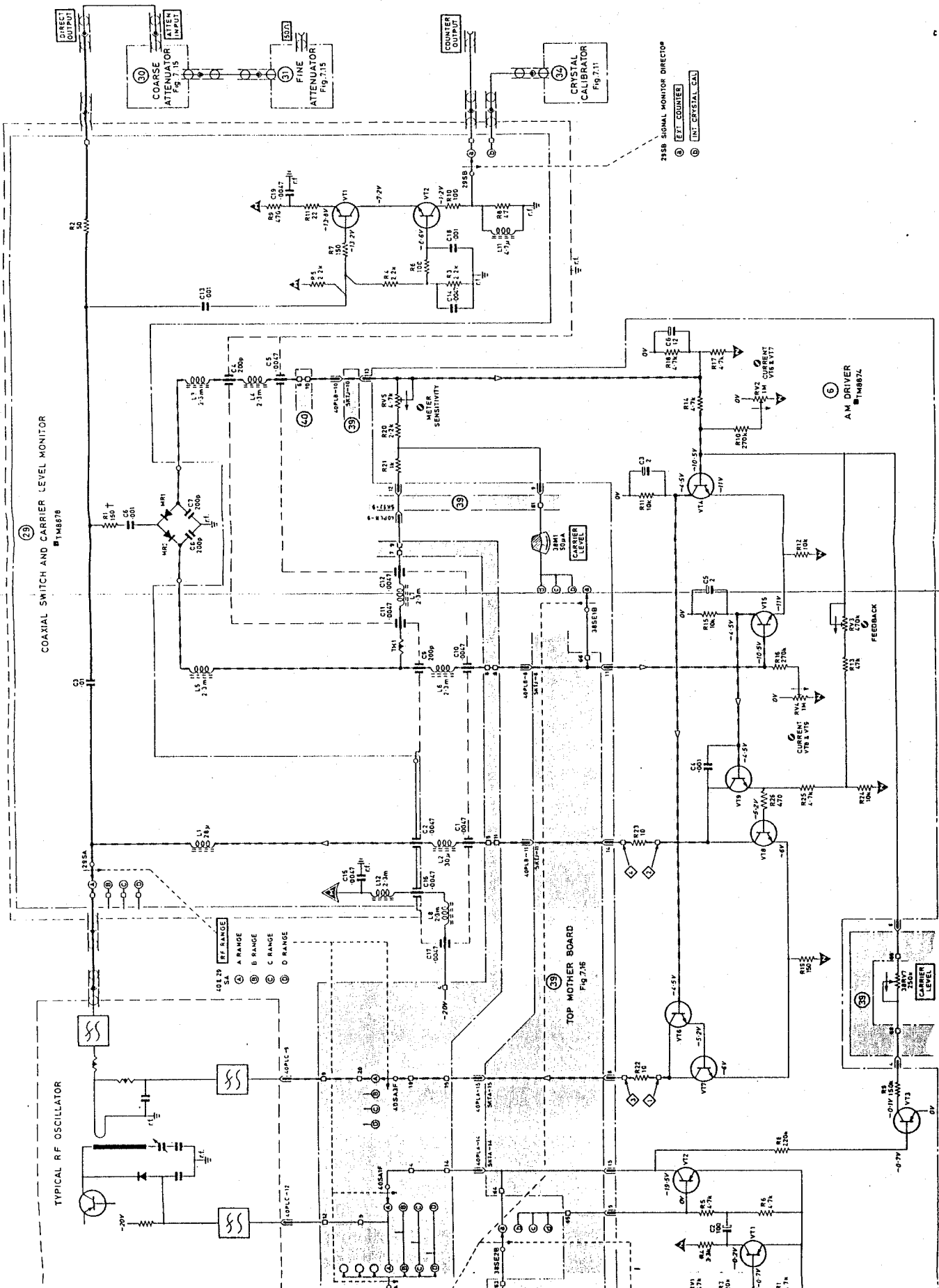
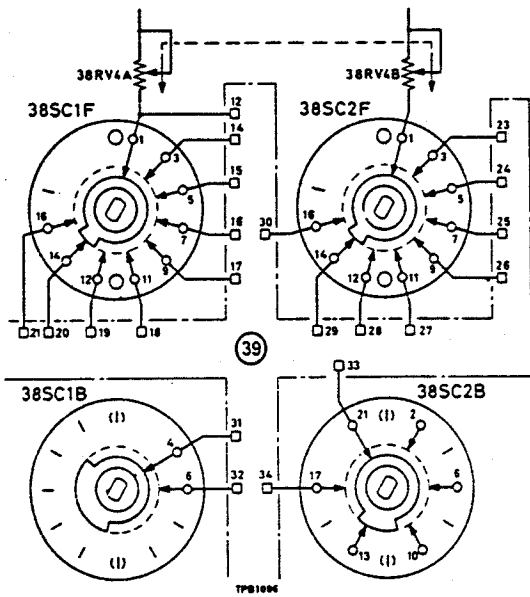
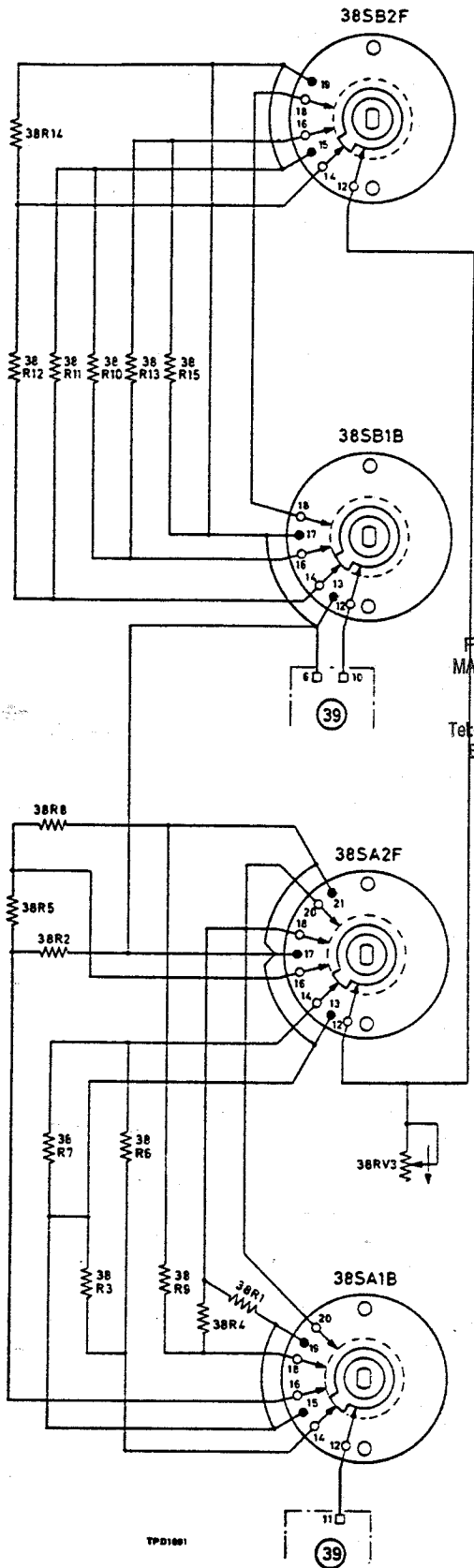

Fig. 7.6 Circuit—Automatic level control and amplitude modulator



For Service Manuals Contact
 MAURITRON TECHNICAL SERVICES
 8 Cherry Tree Rd, Chinnor
 Oxon OX9 4QY
 Tel:- 01844-351494 Fax:- 01844-352554
 Email:- enquires@mauritron.co.uk

Fig. 7.7 38SC plan of sections viewed from knob end
 with switch in 20 k-63 k positions



For Service Manuals Contact
MAURITRON TECHNICAL SERVICES
 8 Cherry Tree Rd, Chinnor
 Oxon OX9 4QY
 Tel: 01844-351684 Fax: 01844-352554
 Email: enquiries@maurtron.co.uk

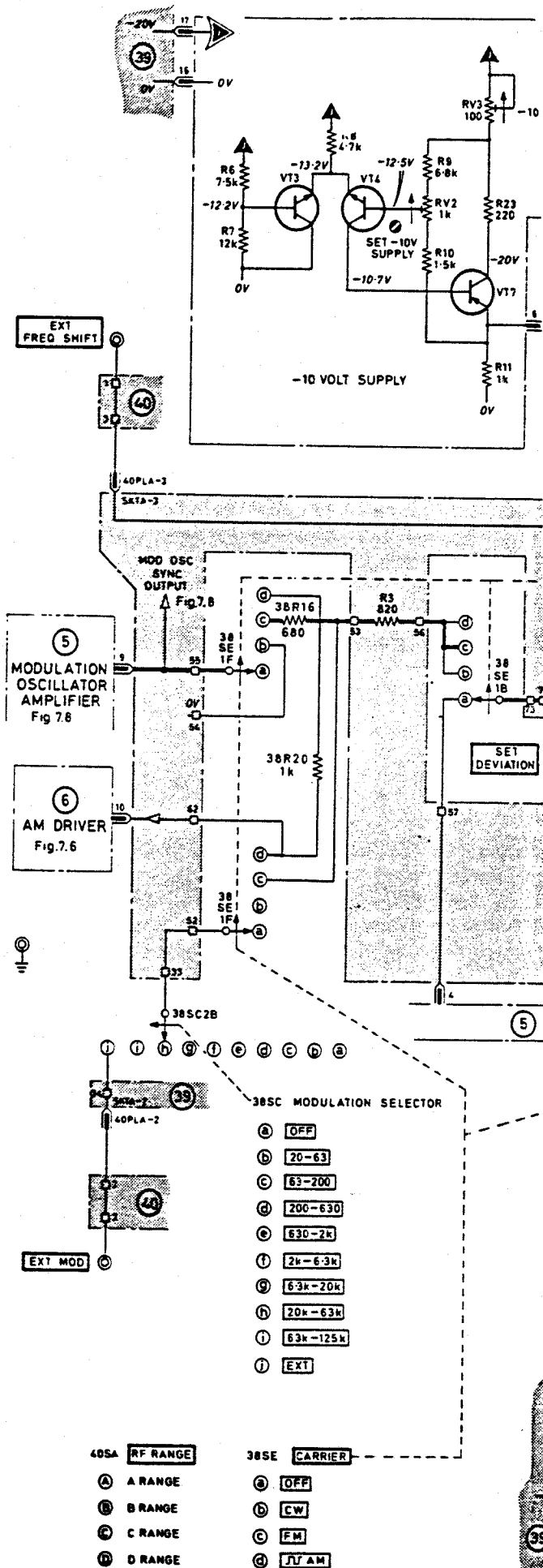

Fig. 7.9 38SB, 38SA plan of sections viewed from knob end with switch in fully counter clockwise position

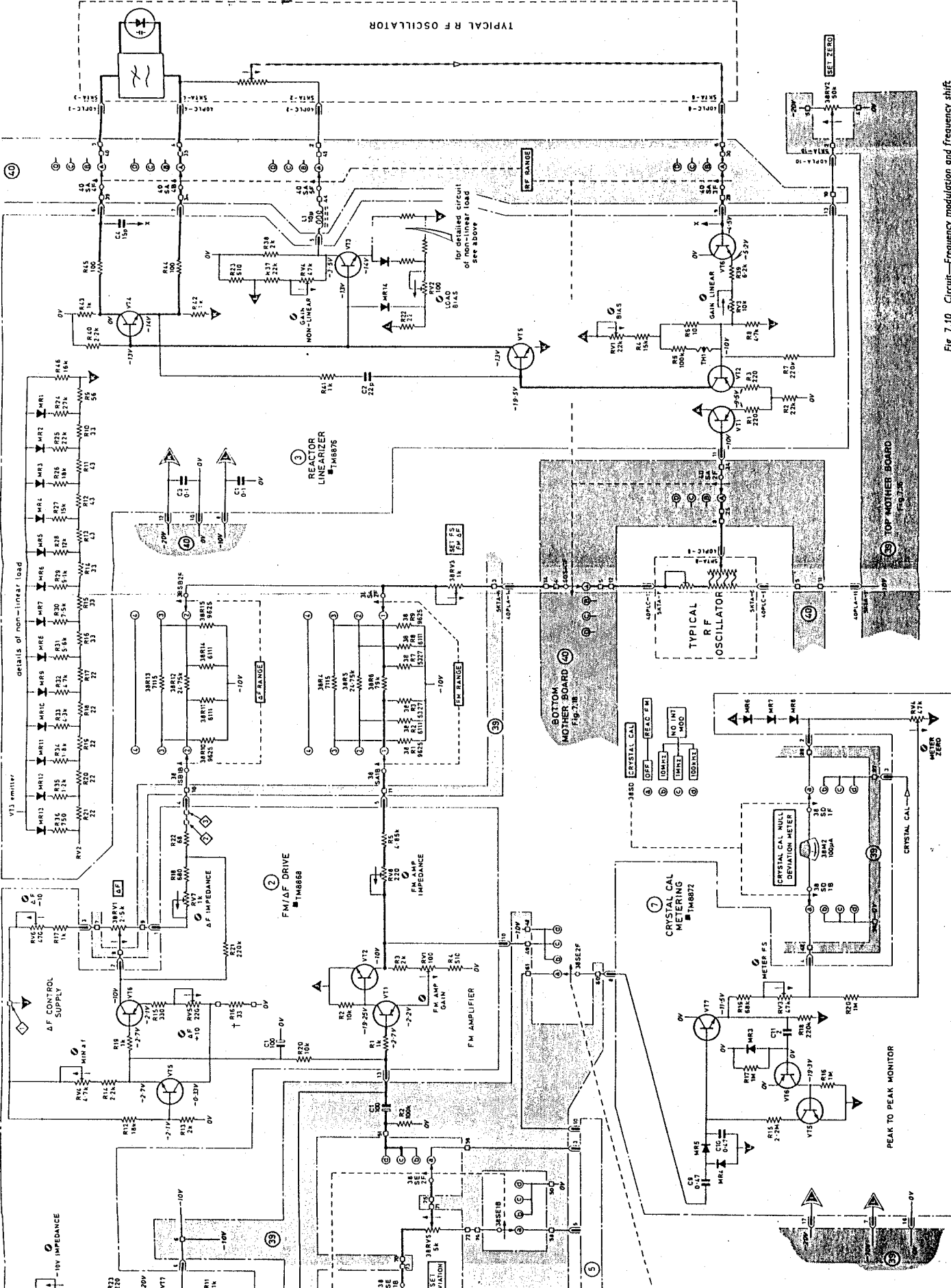
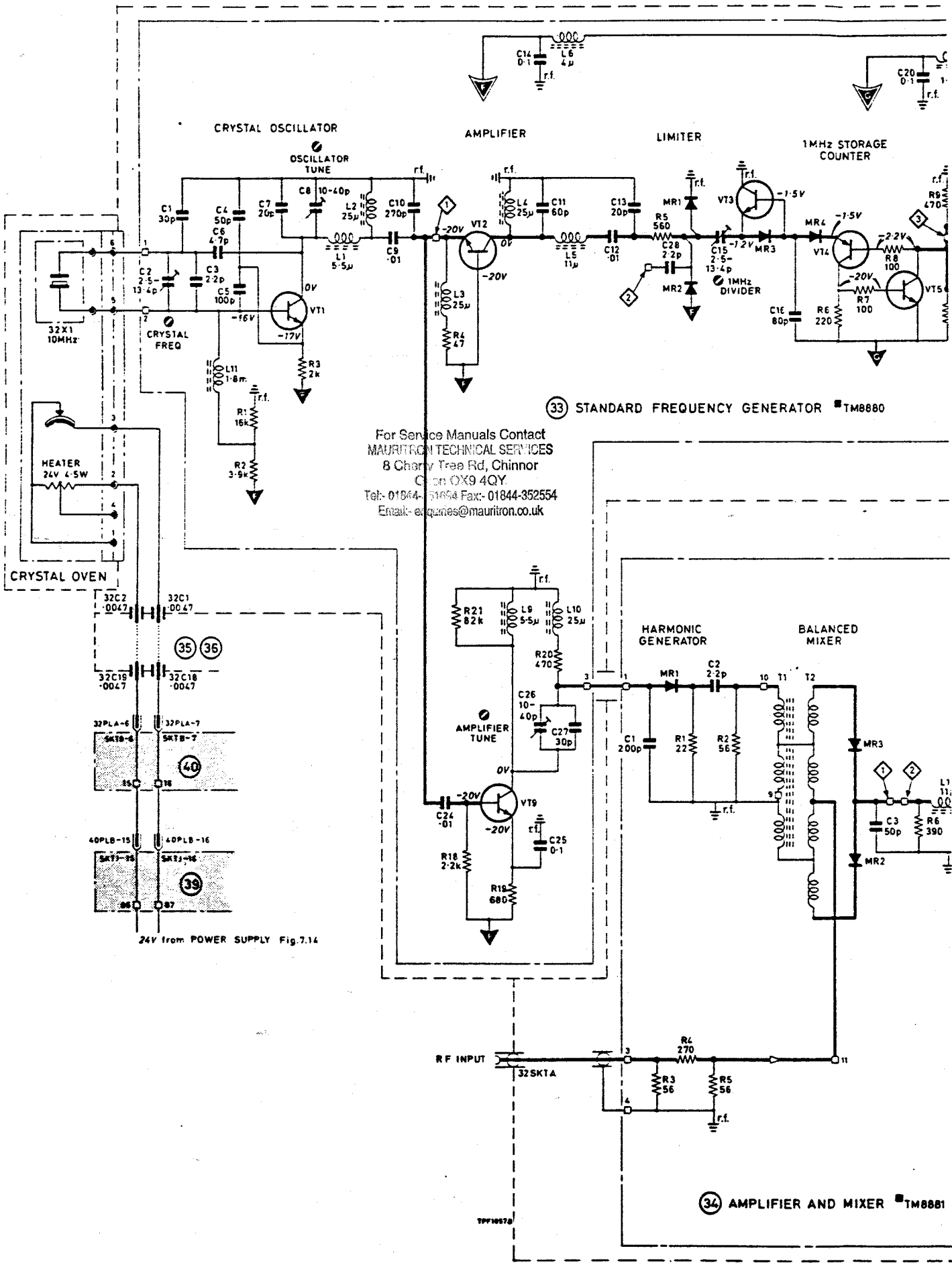

Fig. 7.10 Circuit—Frequency modulation and frequency shift.



For Service Manuals Contact
MAURITRON TECHNICAL SERVICES
 8 Cherry Tree Rd, Chinnor
 Oxon OX9 4QY.
 Tel: 01844-31694 Fax: 01844-352554
 Email: enquiries@mauritron.co.uk

33 STANDARD FREQUENCY GENERATOR TM8880

34 AMPLIFIER AND MIXER TM8881

24V from POWER SUPPLY Fig.7.14

35 TOP MOTHER BOARD
Fig 7.11

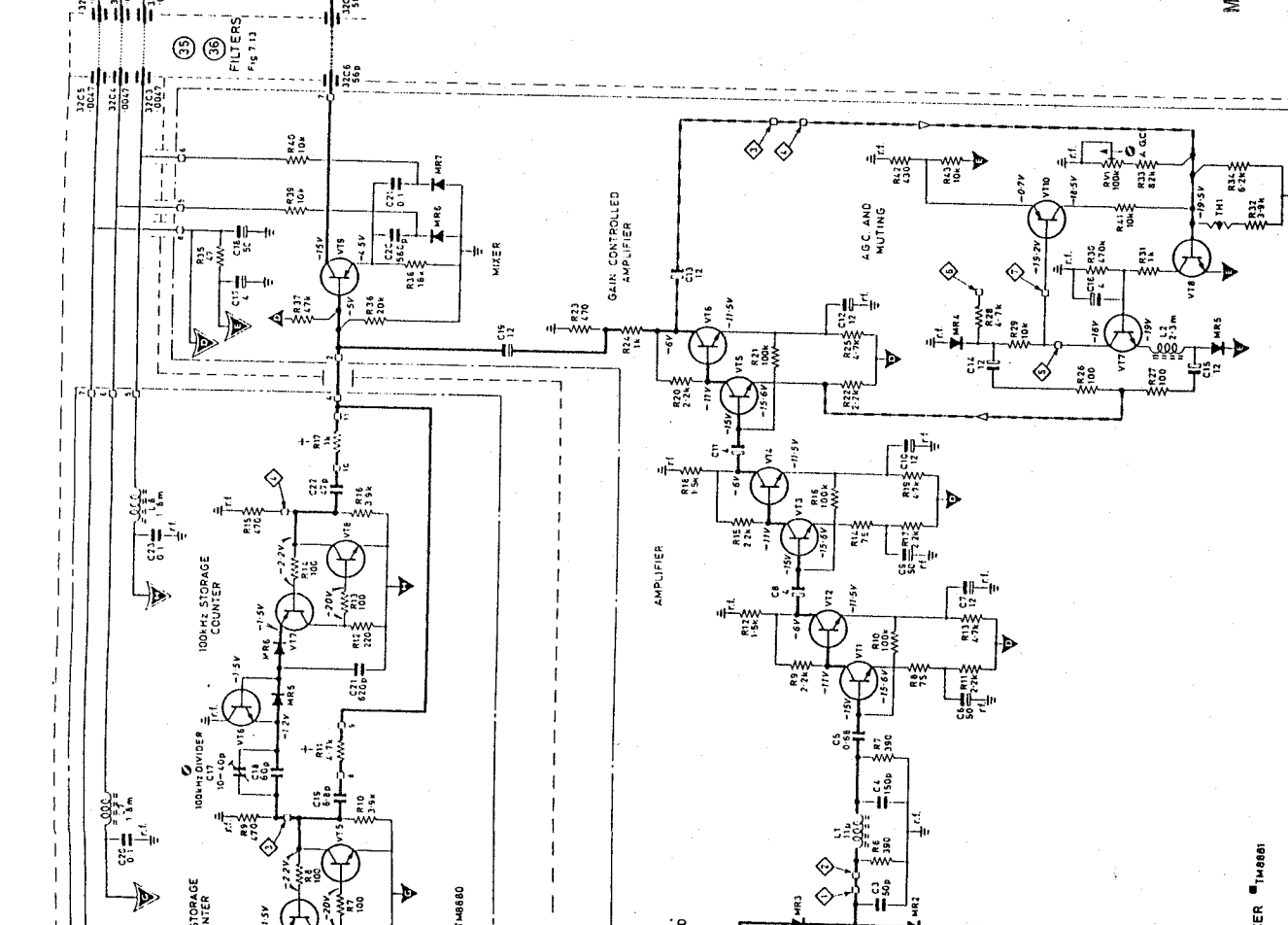
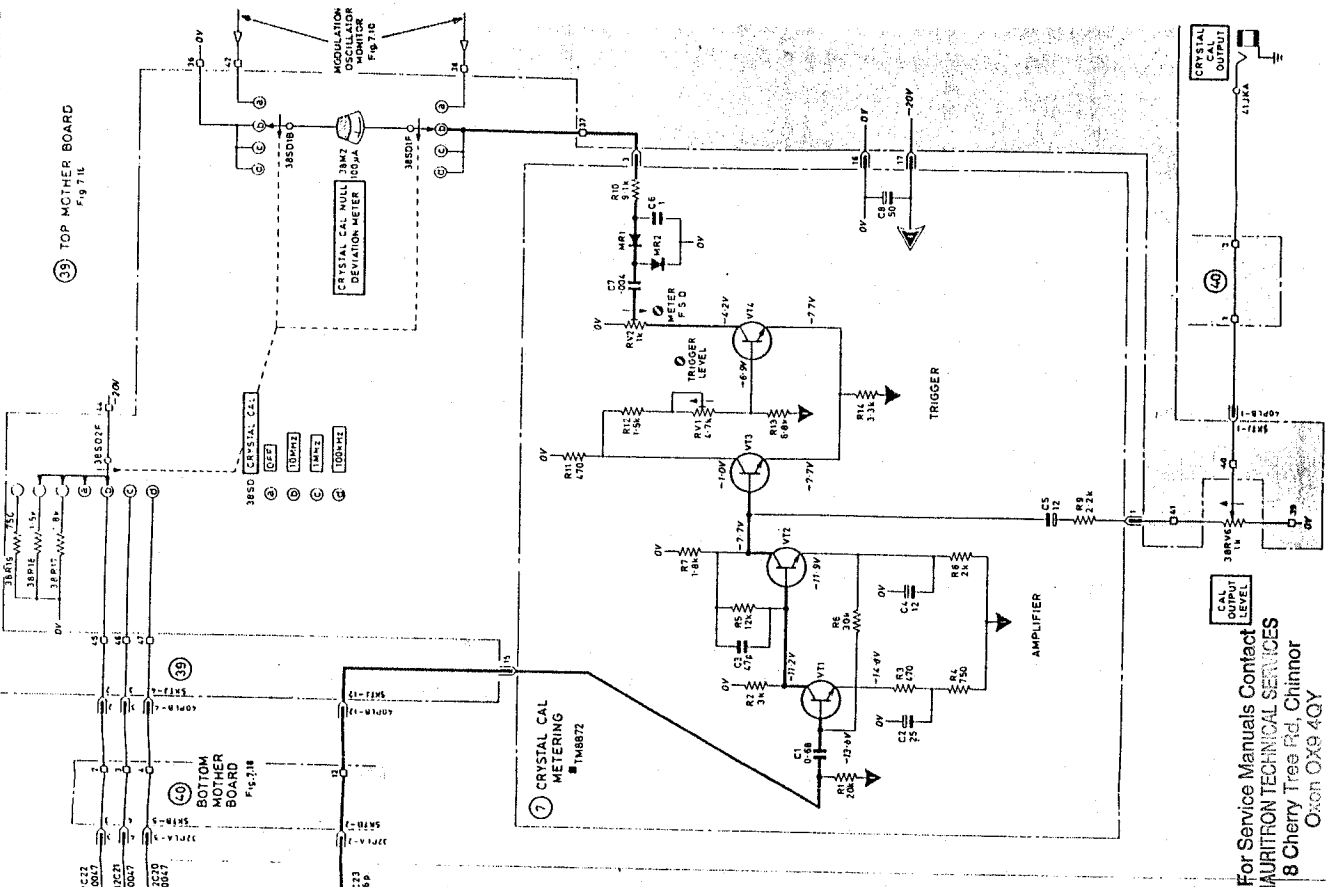
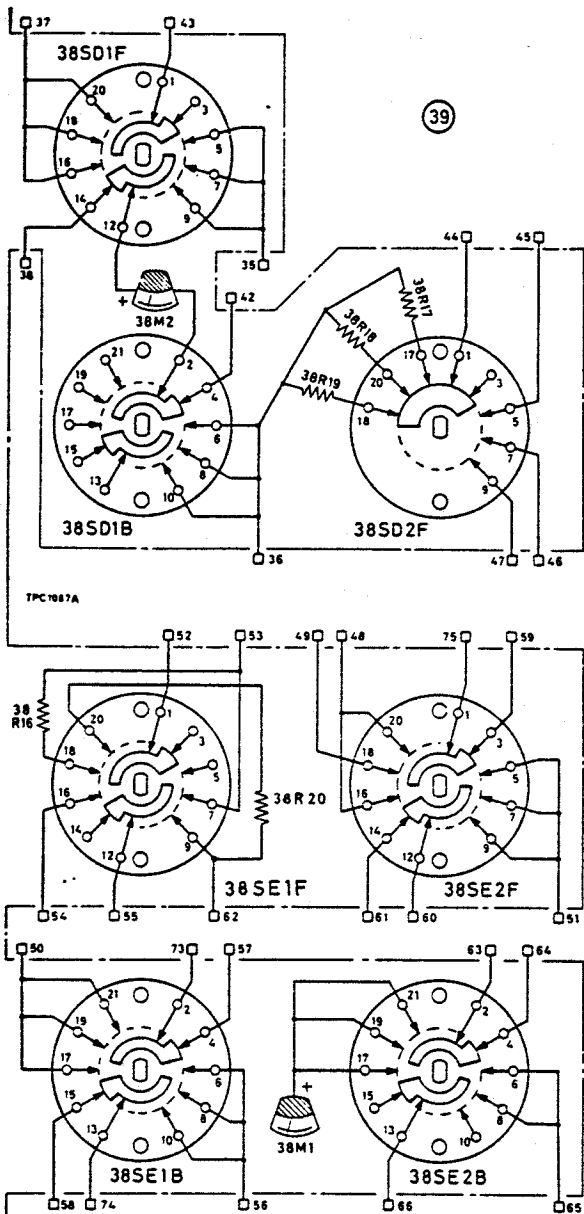

Fig. 7.11 Circuit—crystal calibrator

For Service Manuals Contact
MAURITRON TECHNICAL SERVICES
 18 Cherry Tree Rd, Chinnor
 Oxon OX9 4QY
 Tel: 01844-351634 Fax: 01844-352554
 Email: enquiries@mauritron.co.uk



For Service Manuals Contact
 MAURITRON TECHNICAL SERVICES
 8 Cherry Tree Rd, Chinnor
 Oxon OX9 4QY
 Tel:- 01844-351694 Fax:- 01844-352554
 Email:- enquiries@mauritron.co.uk

Fig. 7.12 38SD, 38SE plan of sections viewed from knob end with switch in fully counter clockwise position

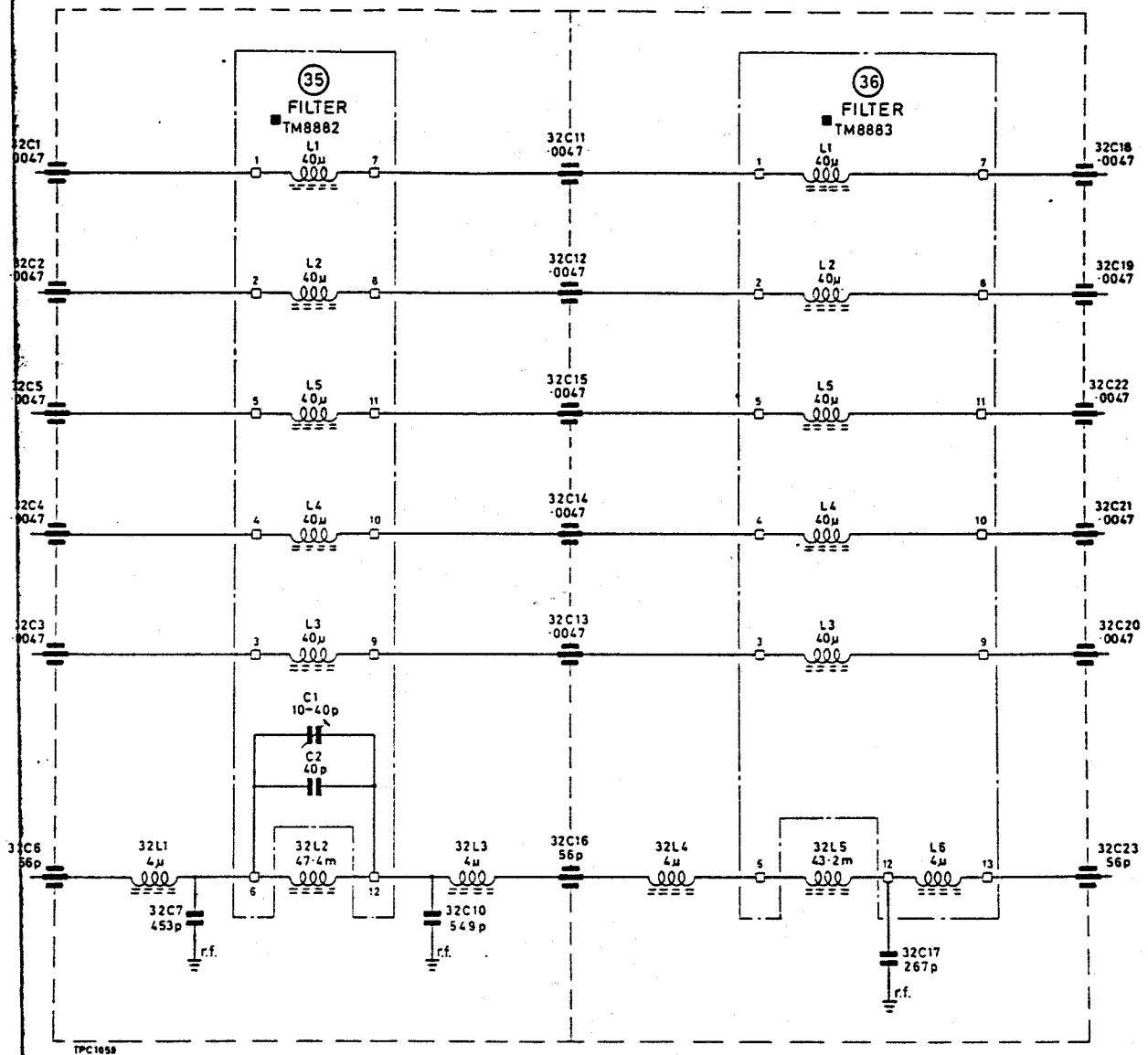

For Service Manuals Contact
 MAURITRON TECHNICAL SERVICES
 8 Cherry Tree Rd, Chinnor
 Oxon OX9 4OY
 Tel:- 01844-351684 Fax:- 01844-352554
 Email:- enquiries@mauritron.co.uk

Fig. 7.13 Circuit—crystal calibrator filters

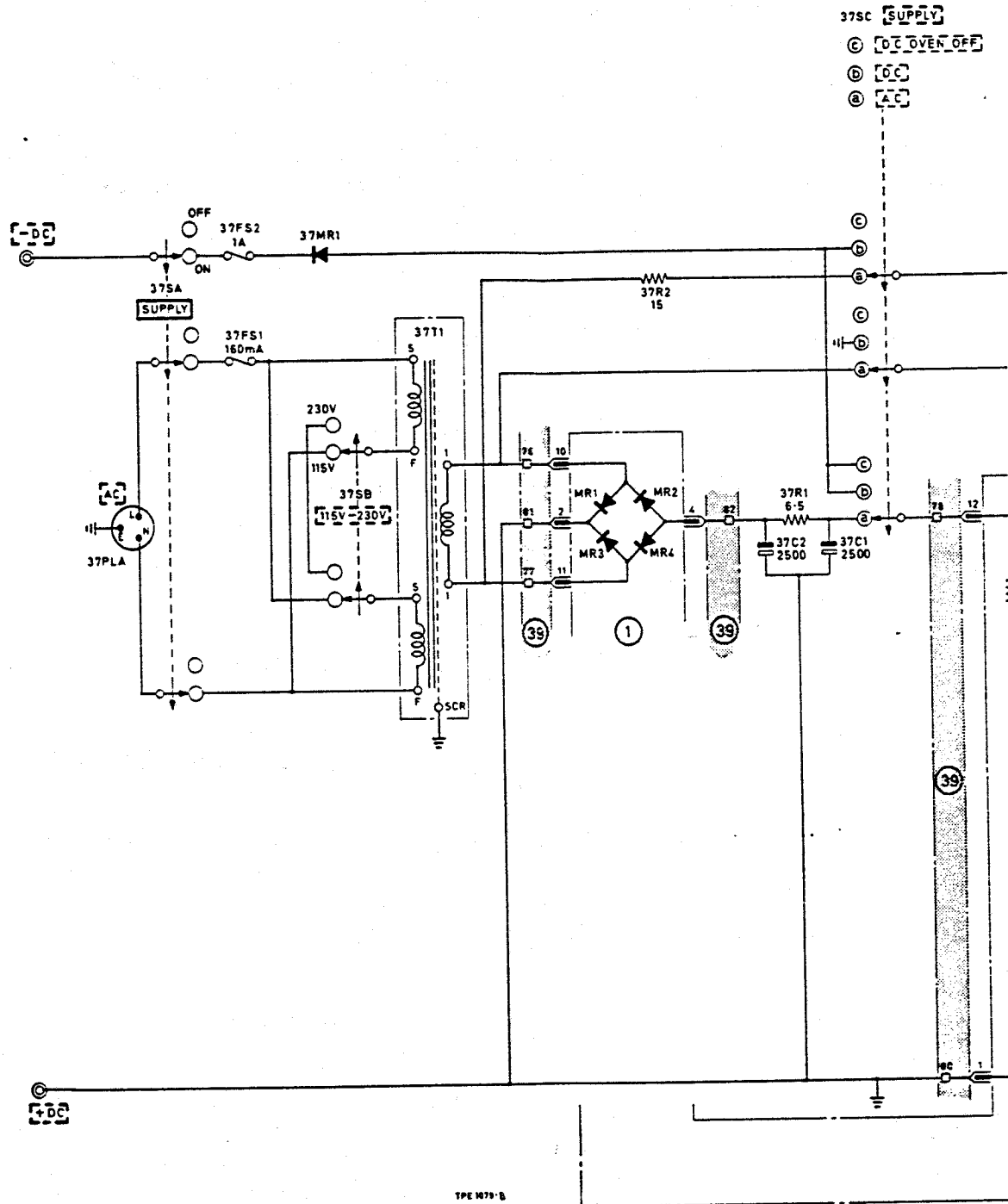

For Service Manuals Contact
 MAURITRON TECHNICAL SERVICES
 8 Cherry Tree Rd, Chinnor
 Oxon OX9 4QY
 Tel:- 01844-351694 Fax:- 01844-352554
 Email:- enquiries@mauritron.co.uk

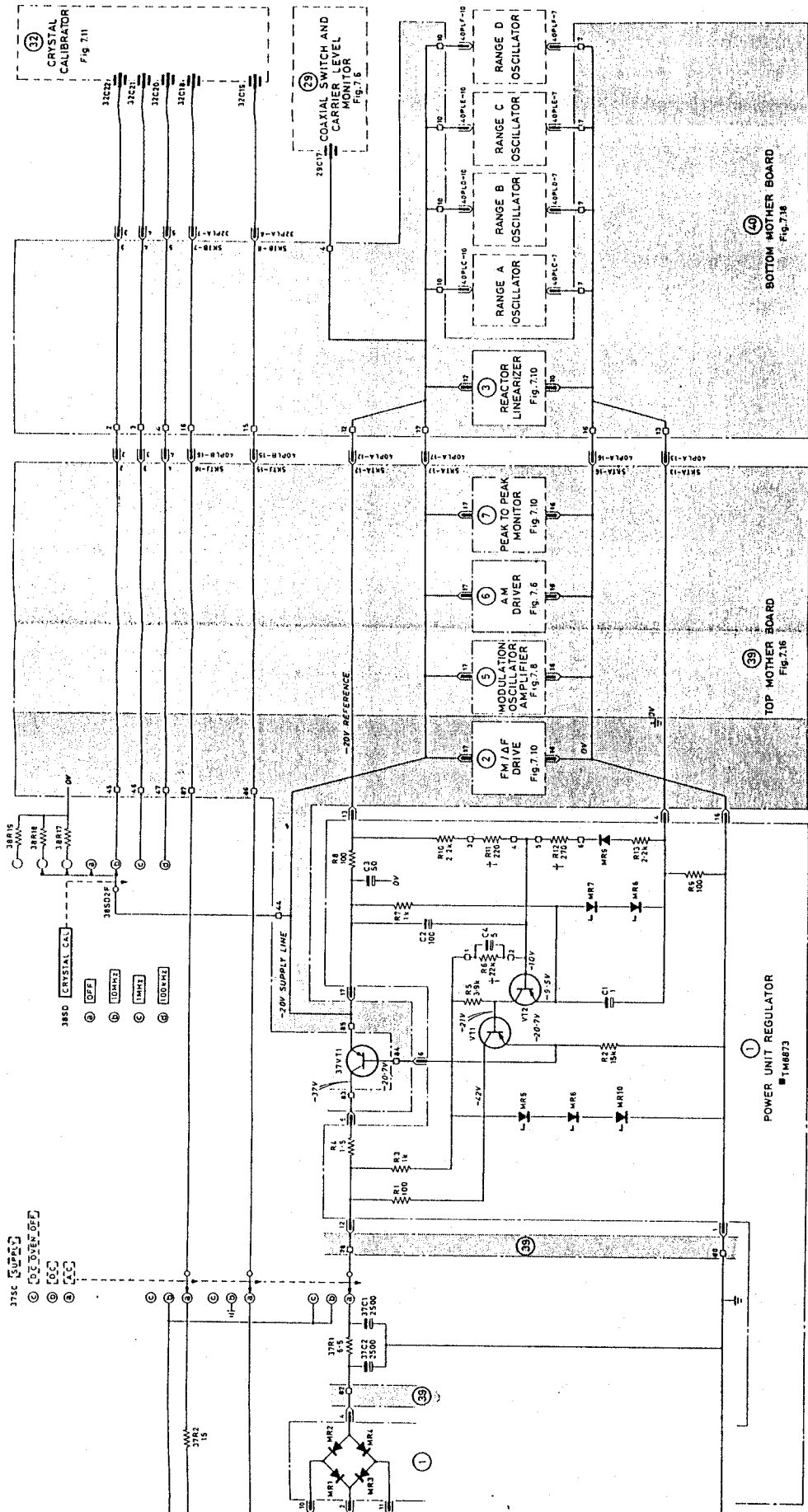

For Service Manuals Contact
MAURITRON TECHNICAL SERVICES
 8 Cherry Tree Rd, Chinnor
 Oxon OX9 4QY
 Tel: 01844-351654 Fax: 01844-352554
 Email: enquiries@mauritron.co.uk

Fig. 7.14 Circuit—power supply

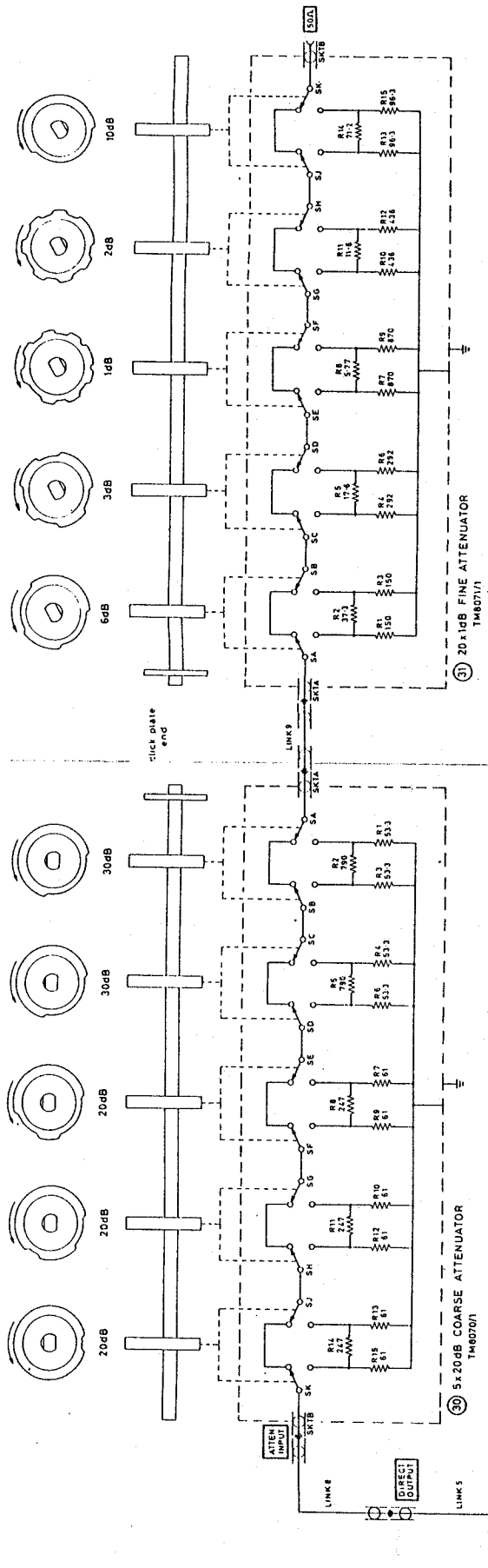

dB ABOVE 1μV ADD		dB																						
0	20	40	60	80	100	20	30	40	50	60	70	80	90	100	110	120	130	140	150	160	170	180	190	200
0	0	0	0	0	0	1	1	1	1	1	1	1	1	1	1	1	1	1	1	1	1	1	1	1
0	0	0	0	0	0	2	2	2	2	2	2	2	2	2	2	2	2	2	2	2	2	2	2	2
0	0	0	0	0	0	3	3	3	3	3	3	3	3	3	3	3	3	3	3	3	3	3	3	3
0	0	0	0	0	0	6	6	6	6	6	6	6	6	6	6	6	6	6	6	6	6	6	6	6
0	0	0	0	0	0	10	10	10	10	10	10	10	10	10	10	10	10	10	10	10	10	10	10	10

For Service Manuals Contact
MAURITRON TECHNICAL SERVICES
 8 Cherry Tree Rd, Chinnor
 Oxon OX9 4QY
 Tel:- 01844-351094 Fax: 01844-352554
 Email:- enquiries@mauritron.co.uk

Fig. 7.15 Circuit—attenuators

- | | | | | | | | |
|-------|----------------------------|-------|--------------------|-------|----------------|-------|-----------------|
| 38 SC | MODULATION SELECTOR | 38 SD | CRYSTAL CAL | 38 SE | CARRIER | 37 SC | |
| (D) | OFF | (D) | OFF | (D) | OFF | (B) | [G.C.] |
| (E) | 20-63 | (E) | 10MHZ | (E) | C.W. | (C) | [G.L.] |
| (C) | 63-200 | (C) | 1MHZ | (C) | F.M. | (C) | [G.C. OVEN OFF] |
| (D) | 200-630 | (D) | 100kHz | (D) | JL F.A.M. | | |
| (E) | 630-2k | | | | | | |
| (F) | 2k-6.3k | | | | | | |
| (G) | 6.3k-20k | | | | | | |
| (H) | 20k-63k | | | | | | |
| (I) | 63k-125k | | | | | | |
| (K) | EXT | | | | | | |

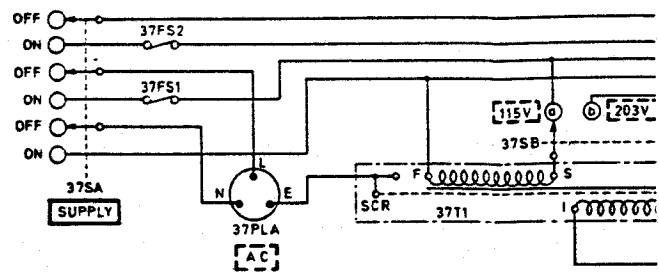

39 TOP MOTHER BOARD TM8857

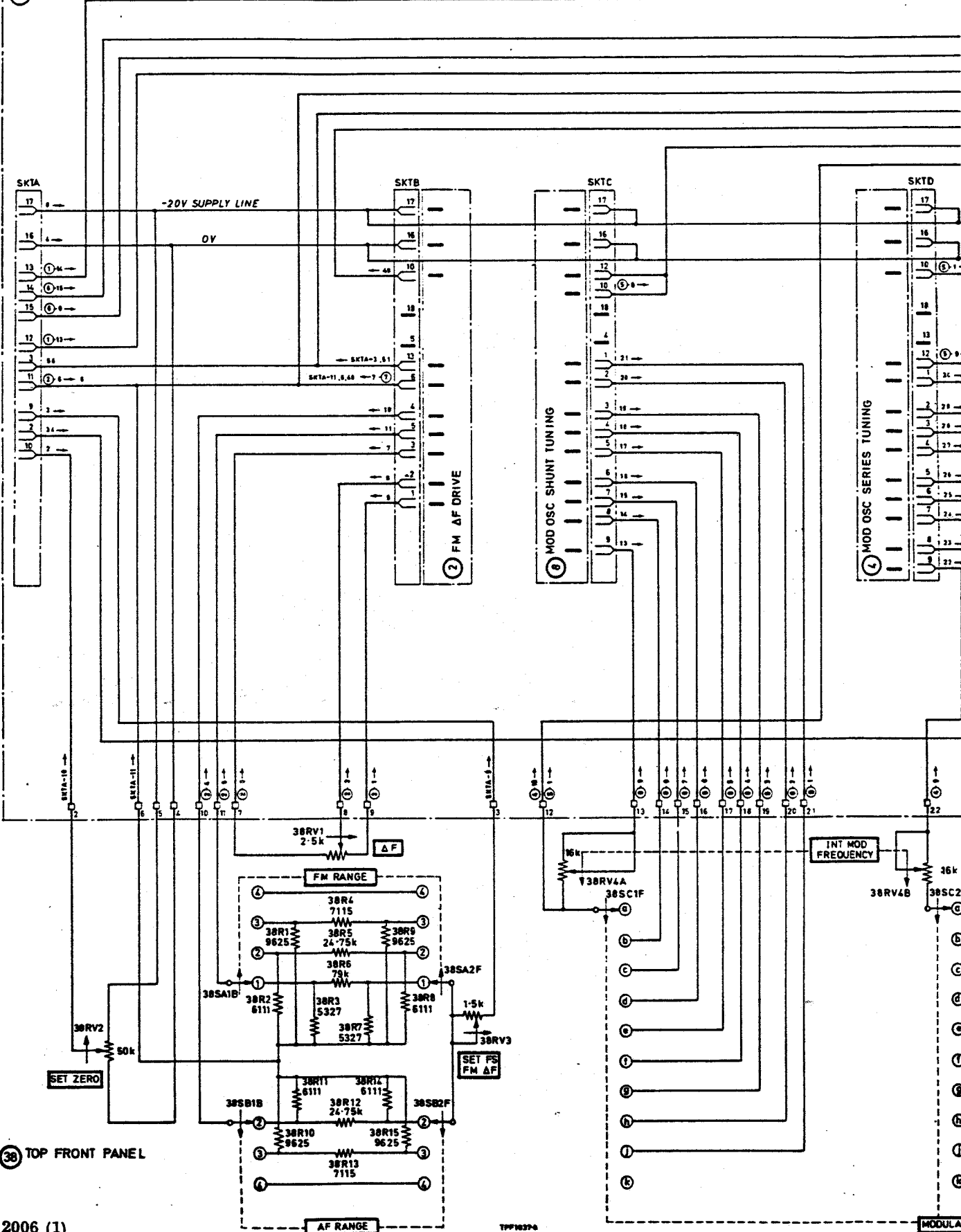

38 TOP FRONT PANEL

For Service Manuals Contact
MAURITRON TECHNICAL SERVICES
 8 Cherry Tree Rd, Chinnor
 Oxon OX9 4QY
 Tel: 01844 891854 Fax: 01844 352554
 Email: enquiries@mauritron.co.uk

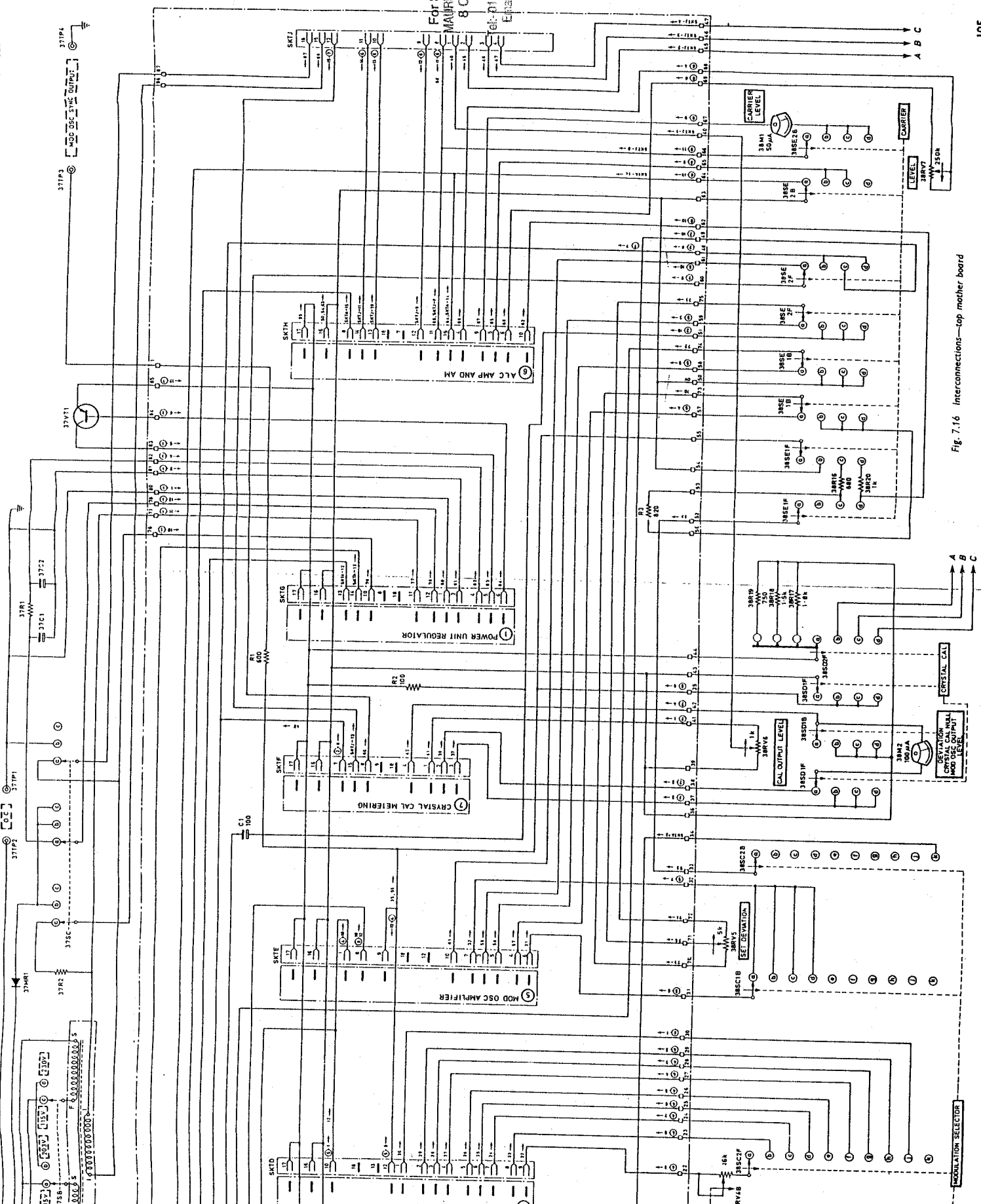
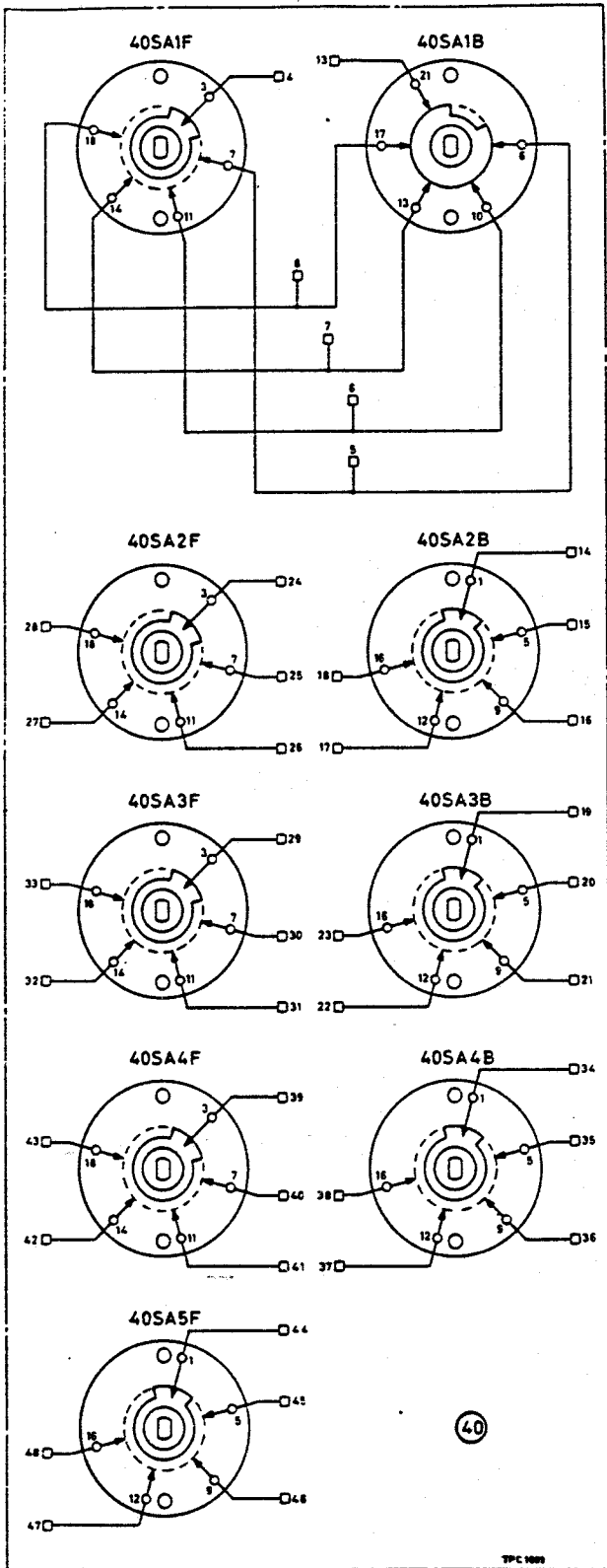

Fig. 7.16 Interconnections—top motherboard



40SA SWITCH SECTIONS

TPC 1000

41 BOTTOM FRONT PANEL

For Service Manuals Contact
 MAURITRON TECHNICAL SERVICES
 8 Cherry Tree Fd, Chinnor
 Oxon OX9 4QY
 Tel: 01844-351884 Fax: 01844-352554
 Email: enquiries@mauritron.co.uk

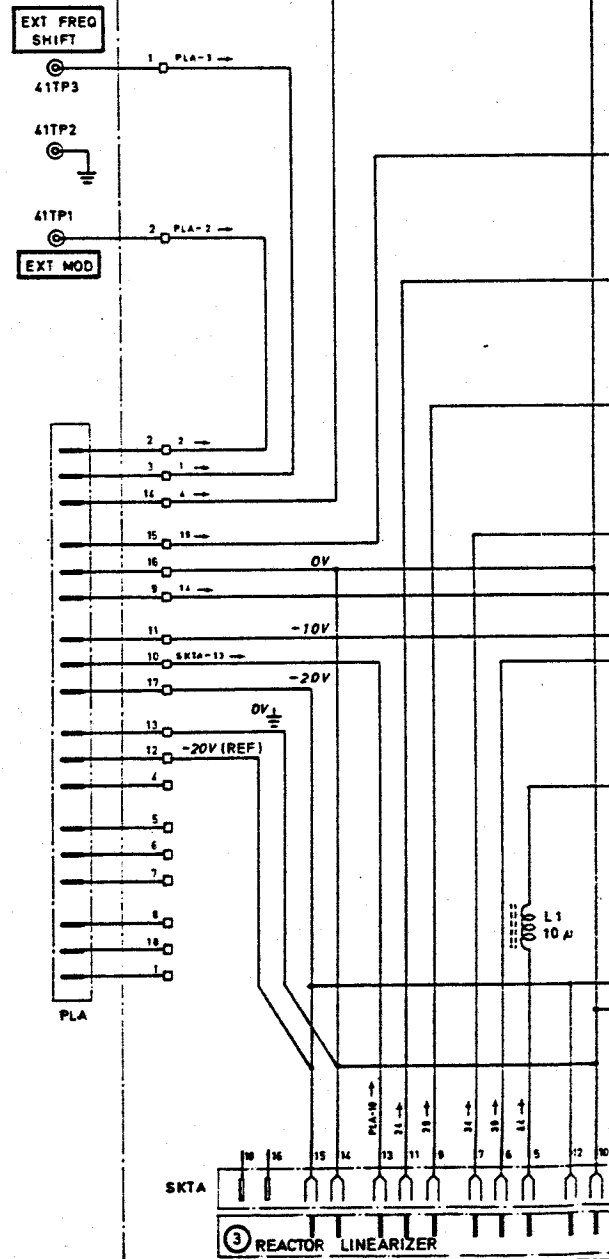

TPF 1030

Fig. 7.17 40SA plan of sections viewed from knob end with switch in fully counter clockwise position

