

Megger®

Megger Limited
Archcliffe Road, Dover
Kent CT17 9EN England
T +44 (0)1 304 502101
F +44 (0)1 304 207342
E uksales@megger.com

Megger
4271 Bronze Way, Dallas,
Texas 75237-1019 USA
T +1 800 723 2861 (USA
ONLY)
T +1 214 333 3201
F +1 214 331 7399
E ussales@megger.com

Megger
Z.A. Du Buisson de la
Coudre
23 rue Eugène Henaff
78190 TRAPPES France
T +33 (0)1 30.16.08.90
F +33 (0)1 34.61.23.77
E infos@megger.com

Megger Pty Limited
Unit 26 9 Hudson Avenue
Castle Hill
Sydney NSW 2125
Australia
T +61 (0)2 9659 2005
F +61 (0)2 9659 2201
E ausales@megger.com

Megger Limited
110 Milner Avenue Unit 1
Scarborough Ontario
M1S 3R2
Canada
T +1 416 298 9688 (Canada
only)
T +1 416 298 6770
F +1 416 298 0848
E casales@megger.com

**This instrument is manufactured in the United Kingdom.
The company reserves the right to change the specification or design without prior notice.**

Megger is a registered trademark

**Part No. 6172-491 V06 0207
www.megger.com**

Megger[®]

BMM2500 Insulation Multimeters

User Guide

CONTENTS

Safety Warnings	3
General Description	4
Continuity Testing	8
Continuity Bleeper	10
Millivolt Tests	11
Capacitance Tests	12
Milliamps Tests	12
Storing Results	13
Datalogging	16
Setup Modes	18
Specification	20
Repair and Warranty	25

Symbols used on the instrument are:



Risk of Electric Shock



Refer to User Guide.



Equipment protected throughout by Double Insulation (Class II).



Equipment complies with current EU Directives.



Equipment must not be connected to installations >500V.



SAFETY WARNINGS

- * **Safety Warnings** and **Precautions** must be read and understood before the instrument is used. They **must** be observed during use.
- * The circuit under test **must** be de-energized and isolated before connections are made except for voltage measurement.
- * Circuit connections **must not** be touched during a test.
- * After insulation tests, capacitive circuits must be allowed to discharge **before** disconnecting the test leads.
- * The Live Circuit Warning and Automatic Discharge are additional safety features and **should not** be regarded as a substitute for normal safe working practice.
- * Replacement fuses **must** be of the correct type and rating. Failure to fit the correctly rated fuse **will** result in **damage** to the instrument in the event of an overload.
- * Test leads, including crocodile clips, **must** be in good order, clean and have no broken or cracked insulation.
- * Ensure that hands remain behind guards of probes/clips when testing.
- * U.K. Safety Authorities recommend the use of fused test leads when measuring voltage on high energy systems.

NOTE

THE INSTRUMENTS MUST ONLY BE USED BY SUITABLY TRAINED AND COMPETENT PERSONS. USERS OF THIS EQUIPMENT AND/OR THEIR EMPLOYERS ARE REMINDED THAT **HEALTH AND SAFETY LEGISLATION** REQUIRE THEM TO CARRY OUT VALID RISK ASSESSMENTS OF ALL ELECTRICAL WORK SO AS TO IDENTIFY POTENTIAL SOURCES OF ELECTRICAL DANGER AND RISK OF ELECTRICAL INJURY SUCH AS FROM INADVERTENT SHORT CIRCUITS. WHERE THE ASSESSMENTS SHOW THAT THE RISK IS SIGNIFICANT THEN THE USE OF FUSED TEST LEADS CONSTRUCTED IN ACCORDANCE WITH THE HSE GUIDANCE NOTE GS38 'ELECTRICAL TEST EQUIPMENT FOR USE BY ELECTRICIANS' SHOULD BE USED.

GENERAL DESCRIPTION

The **Megger® BMM2500** Series instruments are battery powered Insulation and Continuity testers, with a measurement capability from 0,01Ω Continuity to 200GΩ Insulation.

Offering multi-voltage facilities, the instruments take full advantage of microprocessor technology and feature a large liquid crystal display combining digital and analogue readings. The analogue display has the benefit of indicating trends and fluctuations in readings, while the digital readout gives direct accurate results. The display is also backlit giving clear visibility even in low light conditions.

The BMM2500 Series instruments have the unique capability of being able to measure voltages down to a resolution of 0,1mV. This gives the user the option to fit a wide variety of transducers to further enhance the capabilities of the BMM Series instruments, eg temperature or humidity measurement.

A customised connector on the top of the instrument enables the optional **Megger SP6F**

Switched probe to be used for two handed probe operation.

The 250V, 500V and 1000V ranges can be used to test electrical installations in compliance with BS7671 (16th Edition IEEE Wiring Regulations) IEC364 and HD384, since each range has a 1mA minimum test current at the minimum pass values of insulation specified in these documents. The 100V range (BMM2580) is ideal for testing telecommunications equipment which would be damaged by higher voltages. The 50V range (BMM2580) is useful for testing sensitive equipment, such as electronic components, and computer peripherals.

The BMM2500 series instruments have a current facility which enables up to 500mA to be measured, this together with Ω, V and mV ranges means that the instrument can realistically be used in situations where previously a multimeter would be needed. For higher currents an optional current clamp is available.

The BMM2500 series instruments have an RS232 interface built in, and will allow the storage and download of results to a PC. The instruments come with all the necessary software to download and tabulate the results. The download format is also Powersuite compatible enabling instruments to form part of an integrated test and certification system. The BMM2500 series instruments also have the capability to data-log results over an extended time period so that long term measurements of systems can be taken.

Designed to IEC1010-1 the BMM2500 Series are protected against connection to a 500V Category III supply. The instruments have a basic accuracy of $\pm 2\%$ at 20°C. The instruments are waterproof and dustproof to IP54. This helps maintain accuracy and ensures maximum reliability in harsh environments.

OPERATION



Refer to Safety Warnings before using the instrument

Testing is automatically inhibited if:

- An external voltage $>25\text{V}$ is present when switched to any insulation range position.
- An external voltage $>10\text{V}$ is present on all other ranges (excluding **OFF/V/mV**).

The external voltage is indicated on the display, on insulation ranges an audible bleeper will sound if a test is attempted.

Live Circuit Warning

When more than 25V is applied to the terminals in the insulation ranges, the instrument defaults to a voltmeter and gives an audible warning if a test is attempted. On all other switch positions except **OFF/V/mV** when more than 10V is applied the default voltmeter will be activated. Testing will be inhibited.

Voltage Testing on High Energy Systems

Use extreme care when using or measuring



voltages above 30V, particularly in high energy systems. Fused test leads are available as optional accessories for local situations where increased protection is required.

Auto-shut Off

To conserve battery life, Auto-shut Off (preceded by a series of bleeps) operates after approx. 10 minutes of instrument inactivity on insulation, 5 minutes on all other ranges. If the instrument is switched on while holding the  key, the Auto shut-Off time is extended to 60 minutes. To restore operation after Auto-shut Off, select **OFF** followed by the required switch position.

Note: *It is recommended that the instrument is switched to the **OFF** position when not in use.*

Backlight

The backlight is activated by pressing the  key. The backlight will remain illuminated for approx. one minute before automatically switching off to conserve battery life, alternatively the  key can be re-pressed.

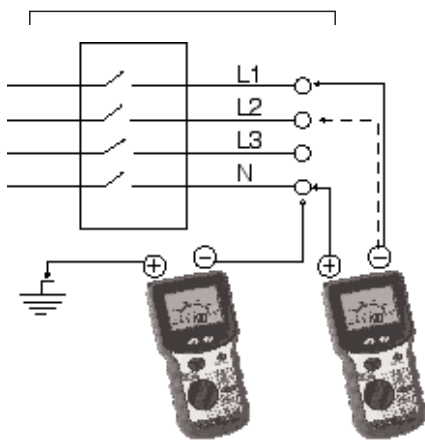

FIG.1

Insulation Tests (MΩ) (See fig.1)



The insulation tests apply a known voltage to the circuit under test and measure the resulting leakage current. The circuit under test must be completely **de-energised** and **isolated** before test connections are made.

Insulation tests are only initiated when the **TEST** button is pressed.



1. Set the range switch to the test voltage required.
2. Connect the test leads, first to the instrument, and then to the isolated item under test.
3. Press the **TEST** button to activate the test voltage. Take the reading.
4. Release the **TEST** button at the end of the test. (Press the **TEST** button if the **ltb** feature is

5. Any capacitive circuits charged during a test will automatically discharge. If significant voltage remains the voltage warning will occur and the voltage present displayed.
6. Remove the test leads only when no voltage is indicated.

Locking Test Button (ltb)

When it is desired to do a long insulation test, the test can be 'locked on' by pressing the  key while the test button is held down. The warning  will appear on the display and both buttons may be released whilst the test continues. The next press of the test button will terminate the test.

Note: There is a short delay on the first operation of '1000 V' range, each time the range is selected. This is to prevent accidental application of 1kV.

The MΩ range features a leakage current display. Leakage current is the value of current that flows during the insulation test. To view the leakage current press the  key. To view insulation resistance press the  key again.

Good procedure whilst Insulation Testing

Care must be taken when taking measurements greater than a few $G\Omega$. The leads must be clean dry and in good condition. They must also not be allowed to tangle. It is also advisable that the switched probe SP6F is not used as the accuracy at high value measurements is not guaranteed. The instrument should also be clean and dry with particular attention paid to the terminals. Also attempt to reduce any leakage that may give erroneous results on the item under test.

Polarisation Index Testing

Polarization Index (**PI**) is the term applied to the Dielectric Absorption Ratio when resistance values are measured after 1 minute and again after 10 minutes. Polarization Index is then the resistance value after 10 minutes divided by the resistance value after 1 minute. The test can be run at any voltage. More detailed information on **PI** Testing and value assessment can be found in Megger Limited publications listed in the Accessories page.

Automatic Discharge

When the **TEST** button is released after an insulation test (or re-pressed if **Itb** feature is enabled), a $200k\Omega$ load is automatically switched across the terminals to discharge the item under test. Any voltage present will be indicated on the display so that the discharge can be monitored.

Typical Terminal Voltage Characteristics

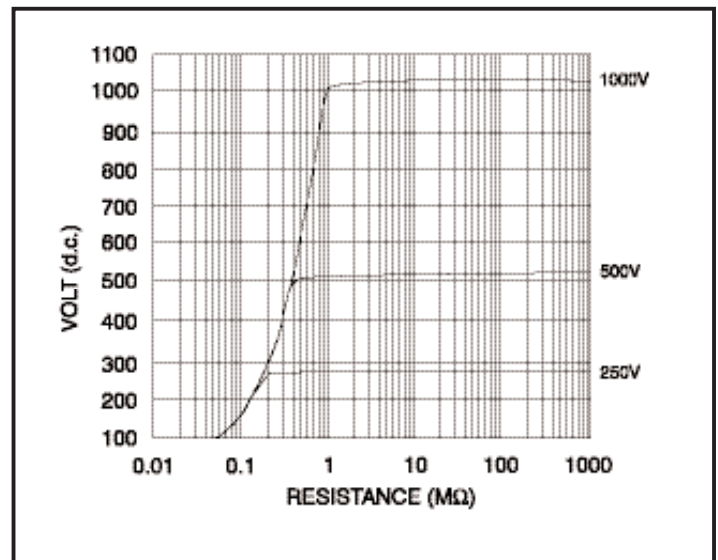

Continuity Testing (Ω) (See fig.2)

The continuity tests are activated when the probes make contact of less than a few $k\Omega$. The test operates without the need to press the **TEST** button. When the test leads are removed the reading will hold for a few seconds and then reset. To recall the last result press the  key. This range is not suitable for diode testing since the automatic contact detector will not be activated when connected to a diode.





1. Set the selector switch to Ω .
2. Connect the test leads.
3. The test will activate automatically.
4. After the test probes are disconnected, the reading will be held for a few seconds.

Zeroing of Test Lead Resistance

The resistance of the test leads can be nulled on the continuity range (up to $9,99\Omega$). The null information is retained in non-volatile memory and so will be remembered when the instrument is switched off.

1. Select the Continuity range.
2. Short the test leads across a known good conductor using prods.

3. When the reading has stabilised, press the **TEST** button. The zero offset symbol  will appear.
4. To release the zero offset press the test button again.

The continuity range features a range lock facility. To **LOCK** the continuity range press the  key, the **LOCK** symbol  will appear. To scroll through the available ranges press the  key. To de-select the **LOCK** feature hold the  key down.

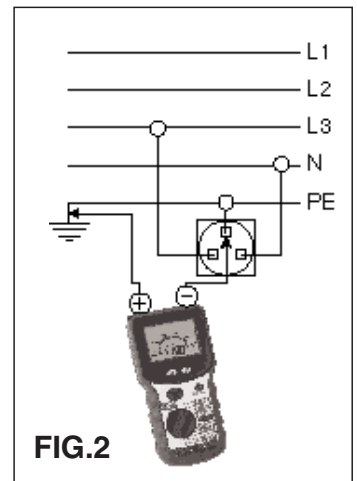

Possible sources of error

Measurements and results can be effected by the following:

- The impedance of operating circuits connected in parallel
- Impedance such as inductors that vary during the measurement
- A poor connection to the circuit under test.

Continuity Bleeper

The continuity bleeper sounds continuously when less than $5\ \Omega$ is detected. Short bleeps will sound for resistances lower than a few $k\Omega$ and above $5\ \Omega$.

1. Set the selector switch to 
2. Connect the test leads.

Display:

$<5\ \Omega$
 $<3k\ \Omega$
 $>3k\ \Omega$

Audible:





continuous bleep
short bleep
no bleep

Resistance Tests ($k\Omega$)

This is a low voltage (5 V) low current ($25\ \mu\text{A}$) test for sensitive electronic equipment. It operates in

the same way as the continuity ranges.

1. Set the selector switch to $k\Omega$.
2. Connect the test leads.
3. The test will activate automatically.

The $k\Omega$ range features a range lock facility. To **LOCK** the $k\Omega$ range press the  key, the **LOCK** symbol  will appear. To scroll through the available ranges press the  key. To de-select the **LOCK** feature hold the  key down.

The resistance range is protected by a high impedance method and therefore if the instrument is connected to a live circuit the fuse will not blow as on the insulation, continuity and buzzer ranges. The instrument will merely indicate the applied over-voltage.

Diode Testing

This range can also be used for diode testing, the positive terminal being the source of the test current. A forward biased semi-conductor junction will typically measure 15 to $30k\ \Omega$, and a reverse junction much higher. These features together with the small test current and wide measurement



range (0,01k Ω to 10000k Ω) make the resistance range very useful for general purpose testing.

Voltage Tests (V)

If >1V a.c. or d.c. is present at the terminals the measured voltage is indicated on the display. The voltage display will function within specification even if the fuse has blown.

If the voltmeter operation is in question, test the voltmeter on a known source.

1. Set the selector switch to V.
2. Connect the test leads.
3. After a short settling time, the reading will be displayed automatically.

To view the frequency of the a.c. V being measured press the  key. The frequency will be displayed in the range 16Hz-460Hz. To view a.c. V press the  key again.

Millivolt Tests(mV)

The measured a.c. or d.c. voltage is indicated on the display.

1. Set the selector switch to mV.

2. Select either a.c. or d.c. mV using the  key.
3. Connect the test leads.
4. After a short settling time, the reading will be displayed automatically.

Note: Live circuit warning does not function on mV range.

Zeroing of d.c. mV (no a.c. mV zero facility)

To zero the d.c. mV range, short the leads together in the d.c. mV position, wait for the reading to settle and then press the **TEST** button. Up to 9,9mV can be zeroed on the d.c. mV range. The symbol  will appear to indicate the zero has been adjusted.

1. Select the d.c. mV range.
2. Short the test leads together.
3. When the reading has stabilised, press the **TEST** button. The zero offset symbol  will appear.
4. To release the zero offset press the **TEST** button again.

To view the frequency of the a.c. mV being measured press the  key. The frequency will be displayed in the range 16Hz-460Hz. To view a.c.

mV press the  key again. For inputs less than 10mV frequency is not displayed.

Capacitance Tests (uF) (BMM2580 only)

The measured capacitance is indicated on the display.

1. Set the selector switch to uF.
2. Connect the test leads to the circuit under test.
3. After a short settling time, the reading will be displayed automatically.

Zeroing of uF

To zero the uF range, disconnect the leads, wait for the reading to settle and then press the **TEST** button. Up to 10,0nF can be zeroed on the **uF** range. The symbol  will appear to indicate the zero has been adjusted.

1. Select the **uF** range.
2. Disconnect the test leads from the circuit under test.
3. When the reading has stabilised, press the **TEST** button. The zero offset symbol will appear.
4. To release the zero offset press the test button again.

The range is suitable for the testing of discrete components and short low interference level signal lines. If electrolytic capacitors are being tested then the red lead should be connected to +ve of the capacitor. This range is not suitable for checking capacitance of signal lines which are subject to high levels of a.c. interference.



When the test is started – – – will show on the display, if there is excessive noise this symbol will remain or flash indicating that there is too much noise for a result to be reached.

Milliamps Tests (mA)

Because of the low source impedance associated with current measuring this test has an added feature ensuring that when the range is first entered the default voltmeter is visible. Testing will be inhibited if more than 25V is present at the terminals. To start testing the **TEST** button should be pressed and held down for approx. 2 seconds to activate the **mA** range. Once activated, the **TEST** button no longer needs to be used and the measured value will be displayed automatically. To switch the display between a.c. and d.c. press the

 key.

1. Set the selector switch to **mA**.
2. Connect the test leads.
3. Select either a.c. or d.c. **mA** using the  key.
4. Press and hold down the **TEST** button for approx. 2 seconds.
5. After a short settle time, the reading will be displayed automatically.



To view the frequency of the a.c. mA being measured press the  key. The frequency will be displayed in the range 16Hz-460Hz. To view a.c. mA press the  key again. For inputs less than 10mA frequency is not displayed.

Storing Results on MΩ and Ω (RCL)

After an insulation test or continuity test the result is displayed on the screen, this may be saved with additional information. A circuit number (**1-99**) may be assigned and circuits may be grouped using the distribution board feature. In this way, when downloading to PowerSuite, the results can be easily split into different test schedules. When the results are displayed or printed, a change in the distribution board is indicated.

Changing Distribution Boards (DB)



Before a test the distribution board number may be changed as follows:-

1. Move the rotary selector switch to the RCL position. The code rcl is displayed.
2. Press the  key. The currently selected DB code is displayed, e.g. **d01**.
3. This number may be changed using the  and  keys to display the required number.
4. The number can be accepted by pressing the key, or aborted by pressing the **EXIT** button.
5. When the number is saved the code **Std** is displayed (accompanied by a long bleep) to confirm that the data has been saved.



Testing may now continue with all subsequent results associated with the new distribution board number.

Storing a result

On completion and display of the measurement:-

1. Press and hold the  key. After about 1 second, a bleep will be heard. For both Continuity and Insulation, a code, as given in the following table is displayed. This code is used to describe the circuit tested and can accordingly be modified by the user.
2. The code may be changed by pressing the  and  keys.
3. The code may be accepted by pressing the key, or aborted by pressing the **EXIT** button.
4. The circuit number is then displayed as 2 digits e.g. c01.

Note:- Many different tests may be saved under the same circuit number.



5. The circuit number may be changed by pressing the  and  keys to display an appropriate number.
6. The number can be accepted and the results saved by pressing the  key, or the

procedure aborted by pressing the EXIT button.

7. When the result is saved, the code **Std** is displayed (accompanied by a long bleep) to confirm that the data has been saved. The display of **FULL** indicates that there is no more test storage. Approx. 300 results can be stored in memory.

Test to be Saved	Display code	Meaning
Continuity	r1	Single CCT
	r2	Single CCT
	rr1	Ring CCT
	rr2	Ring CCT
	rn	Ring CCT
	r12	R1+R2 ReturnCCT
Insulation	n_e	N-PE
	L_n	L-N
	L_E	L-PE
	L_L	L-L

Delete all data



1. Move the rotary selector switch to the **RCL** position. The code **rcl** is displayed.
2. Press the  and  keys together. The code **dEL** is displayed.
3. Confirm that the data is no longer required by pressing the  key or abort by pressing any other key. The code **rcl** is displayed.

Print Results (see Setup Modes)





1. Connect printer and the instrument with a serial printer lead.
2. Move the rotary selector switch to the **RCL** position. The code **rcl** is displayed.
3. Commence the printout by pressing the **TEST** button. Abort at any time by pressing and holding the  key. The code **rcl** is displayed.

Retrieve Stored Results



It is possible to view previously stored test results by switching the rotary switch to the **RCL** position.

1. Move the rotary selector switch to the **RCL** position. The code **rcl** is displayed.
2. Select the required distribution board by pressing the  and  keys.

The distribution board numbers are shown in the order that the results were stored. A long beep is sounded when the end of the list is reached.

3. Press the  key to list the circuit numbers used in the currently displayed distribution board or press the **EXIT** button to return to the **RCL** display.
4. Select the required circuit number by pressing the  and  keys. The circuit numbers are shown in the order that the results were stored. A long beep is sounded when the end of the list is reached.
5. Press the **EXIT** button to return to the distribution board selection screen, or press the  key to show the stored test codes. The following codes are used to identify test results:-

Code	Meaning
Con	Continuity Test
InS	Insulation Test

6. Select the required test by pressing the  and  keys. The tests are shown in

the above order. Hold a key down to auto-repeat. A long bleep is sounded when the end of the list is reached.

7. Press the **EXIT** button to return to the circuit number selection screen, or press the  key to scroll through the stored test results, together with any additional connection information.

Download to PC

The BMM series has been designed to be used with AVO Powersuite for Windows which will accept the test results and enable the production of various certificates, including Periodic Inspection and Completion. The CD supplied with the instrument contains Download Manager Program. This enables stored and data-logged results to be downloaded to a PC, the creation of simple test report files which may be exported to other applications and used to create data backups or reports/certificates. Download manager also enables certain changes to be made to your instrument setup such as changing the 2nd language of the printouts. The CD contains a user

guide giving you full instructions on the use of Download Manager.

Cable Configuration

Normally, a double-ended 9-way 'D' female socket lead suitable for connecting PC to PC is required. This lead should not exceed 3m in length. A lead is available as an accessory, or one can be made up as follows:-

Signal	Insulation Tester	9-way 'D'	25-way 'D'
Rx	2	3	2
Tx	3	2	3
DSR	6	4	20
GND	5	5	7

Datalogging

Datalogging means the automatic recording of measurements at regular intervals over an extended period, for viewing at a later time. Results are held in the internal memory of the tester, but can only be extracted by means of a PC connected via the RS232 port.



Storage v. Datalogging Comparison.

By storage, we mean the saving to memory of results one-by-one as tests are performed. Each result has to be individually saved after associating it with user-selectable connection data and circuit number, along with a previously chosen distribution board number. However, when data logging is running, results are automatically and continuously saved to memory and no other information is recorded.

Storage and logging are mutually exclusive functions. The instrument cannot be set up to perform both operations at any given time. If a result is stored, then all logged data is erased, and vice versa. Also, only one set of logged data can be held in memory. A new logging session will erase the previous data. This differs in behaviour from the storage function, in which data from successive tests accumulates in the memory until it is full. Another difference between storage and logging is that the former applies only to insulation and continuity testing, whereas all types of measurement can be logged (buzzer range excluded).

Starting a logging session

Once logging has been enabled and the interval set up, a session of data-logging can begin. (see Setup Modes)

1. Hold down the  key and turn the rotary switch to the desired function.
2. Release the  key. The message log will be seen. To confirm that logging is required, press the display key and a confirming message will be shown briefly.
3. Pressing **EXIT** will cancel logging and off will be displayed.

If data-logging is turned on, it will commence as soon as the test starts. That is, immediately on volts, millivolts, ohms, $k\Omega$ and capacitance functions, or when the test button is pressed on insulation and milliamps ranges. On milliamps or millivolts functions, press the  key if required, after logging has started.

Stopping a logging session

While a logging session is running, it can be stopped at any time by turning the range switch. Any data logged up to that point will be retained.

Alternatively, logging can be left running and will stop automatically a short while after the memory becomes full.

The number of results which can be logged is about 300, after which the message 'full' will be flashed on the display for a few minutes. The instrument will then shut down.

Other considerations

Note that the batteries may not last through the whole logging session, depending on their condition and on the log interval which has been set. If the batteries should fail, any results already logged will be retained. Note also, that if the **TEST** button has been set for non-latching operation, this will be temporarily overridden during logging of insulation results, giving a press-to-start, press-to-stop action. The **TEST** button's mode of operation will return to its original setting after the logging session has finished.

Viewing logged data.

Logged results can only be retrieved via the instrument's RS232 port, using a PC connected via a serial cable. The disk supplied with the

instrument carries a programme capable of handling the data. The method is similar to that for 'downloading' stored results. For further information see the section entitled "Download to PC". Note that on millivolts d.c. and milliamps d.c. measurements, the frequency result is always set to zero. On millivolts a.c. and milliamps a.c. measurements, the frequency result is set to zero if the frequency could not be measured.

Setup Modes



Serial Printer configuration

The printer should be set to 9600 baud, 8 bit data, no parity and 1 stop bit. This instrument uses a special isolated serial interface which is powered from the PC or printer. In the unlikely event that your PC or printer is not able to power the interface, it will be necessary to provide an additional supply. Contact **Megger Product Support** for details.





Printer Setup Mode

The instrument cannot respond to a busy signal



given by a printer, and therefore waits at the end of each line. This time ("Printer delay time") and the printer report language can be changed.

1. Press and hold the  key then turn the rotary selector switch from the **OFF** position to the **RCL** position. The code **Pdt** is displayed.
2. Release the  key.



To change the Printer speed

1. Toggle the  key to scroll through and display the code **Pdt**
2. Press the  key. The current setting is displayed.
3. Toggle the  and  keys until the required setting is displayed.
4. To save the new setting, press the  key. The bleeper sounds and **std** is displayed. To abort the new setting, press the **EXIT** button.

To select the printer language

1. Press the  key to scroll through and display the code **lng**.
2. Press the  key. The current printer report language is displayed as 1 (English) or 2 (as given on the type label on the User Guide cover).

Note: Language 2 can be changed – see below.

3. Press the  key until the required language setting is displayed
4. To save the new setting, press the  key. The bleeper sounds and is **Std** displayed. To abort the new setting, press the **EXIT** button.





Changing the Second Printer Language

Language 2 can be changed using Download Manager Program supplied with your instrument. Full instructions are contained in the User Guide with the CD.





Data-logging

Enabling/disabling data-logging:

The factory setting is that logging is disabled and storage is enabled.

1. Turn the range knob to '**RCL**' while holding down the  key. **Pdt** will be displayed.
2. Press the  key until log is showing
3. Press the  key to show the current status of the logging function, i.e on or off.
4. Pressing the  key toggles the setting between on and off.
5. Press the  key to accept the setup, or the **EXIT** button to quit.

Setting the data-logging interval.

1. While log is being displayed, press the  key. **Int** will appear on the display.
2. Press the  key to see the value of the logging interval (in seconds)
3. Set the interval in 10 second steps with the  and  keys (max. value 1990 seconds, min. value 10 seconds)
4. Press the  key to accept the new value, or the **EXIT** button to quit.
5. Press the **EXIT** button again to escape from the logging setup screens. The display will show **rcl**.

Using the Megger SP6F Switched Probe Operation

The **Megger SP6F** is an accessory for designated Megger installation test instruments. When fitted in the specially designed connector, in place of the existing 'Low' lead, the SP6F acts as a remote test button to operate the instrument and as a 'Low' probe. This simplifies instrument control and two-handed probing. The SP6F is suitable for use with Megger insulation test instruments up to 1kV output test voltage.

Safety

Meets the safety requirements for double insulation to IEC1010-2-031 (1995), EN61010-2-031 (1995), IEC 1010-1 (1995), EN61010-1 (1995) Category III* 300 V phase to earth and 500V phase to phase. The probe is fitted with an internal, non-replaceable fuse, to protect the user should the probe be used accidentally in conjunction with a testlead in the low terminal.

*Relates to transient overvoltage likely to be found in fixed installation wiring.

 **Do not use the probe if any part of it is damaged.**

Battery Replacement

When the low battery symbol  appears, the cells are nearly exhausted and should be replaced as soon as possible. Use Alkaline cells IEC LR6 (AA) or NiCd rechargeable. To install or replace the cells, disconnect the test leads, switch the instrument to **OFF** and loosen the captive screws on the rear of the battery compartment. Remove the cover and disconnect the battery holder from the battery leads. Ensure that the replacement

cells are fitted with the correct polarity in accordance with the label in the battery holder. Reconnect the battery holder to the battery leads. Replace and re-secure the battery compartment cover. Remove the cells if the instrument is not going to be used for an extended period of time.

Fuse Checking and Replacement

To check the instrument fuse, switch to an insulation range and press the **TEST** button. The symbol  will appear if the fuse is ruptured. To replace the fuse, disconnect the test leads, switch the instrument **OFF** and loosen the captive screws holding the battery compartment cover in place. Remove the cover and replace the fuse. Replace and re-secure the battery compartment cover.

Specification

(All quoted accuracies are at +20°C.)

INSULATION RANGES

Nominal Test Voltage (d.c.): 250V,500V,1000V (BMM2500)
50V,100V,250V,500V,1000V (BMM2580)

Test voltage accuracy: +15% maximum on open circuit

Short circuit current: < 2 mA

Test Current on load: 1mA at min. pass value of insulation specified in BS7671, HD384 and IEC 364, 2mA max.

Accuracy:
(BMM2500)

Range	Full Scale	Accuracy
1000V	20GΩ	± 2% ± 2 digits ± 0,2% per GΩ
500V	10GΩ	± 2% ± 2 digits ± 0,4% per GΩ
250V	5GΩ	± 2% ± 2 digits ± 0,8% per GΩ

(BMM2580)

Range	Full Scale	Accuracy
1000V	200GΩ	± 2% ± 2 digits ± 0,2% per GΩ
500V	100GΩ	± 2% ± 2 digits ± 0,4% per GΩ
250V	50GΩ	± 2% ± 2 digits ± 0,8% per GΩ
100V	20GΩ	± 2% ± 2 digits ± 2,0% per GΩ
50V	10GΩ	± 2% ± 2 digits ± 4,0% per GΩ

Note: Above specifications only apply when high quality silicone leads are being used.

Measuring Range:

0,01MΩ to 200GΩ (0-100GΩ on analogue scale).

EN61557 Operating range: 0,10MΩ to 1,00GΩ

Leakage Current: 10% ±3digits

CONTINUITY

Measuring Range: 0,01Ω to 99,9Ω (0 to 10Ω on analogue scale)

EN61557 Operating range: 0,10Ω to 99,9Ω

Accuracy: ±2% ±2 digits

Open circuit voltage: 5V ±1V

Test current: 210mA ±10mA (0-2Ω)

Zero offset at probes: 0,10Ω typical

Lead resistance zeroing: Up to 9,99Ω

Noise rejection: 1V rms 50/60Hz

Buzzer: Operates at less than 5Ω (approx).

RESISTANCE

Measuring Range: 0,01kΩ to 9,99MΩ (0 to 100MΩ on analogue scale)

Accuracy: ±3% ±2 digits

Open circuit voltage: 5V ±1V

Short circuit current: 25µA ±5 µA

VOLTAGE

Measuring Range: $\pm 1\text{V}$ to $\pm 500\text{V}$ (0 to 1000V on analogue scale)
Accuracy: 0-500V d.c. $\pm 2\%$ ± 3 digit
0-500V a.c (50/60Hz) $\pm 2\%$ ± 3 digits
0-500V 400Hz a.c. $\pm 5\%$ ± 3 digits
Input resistance: approx 200k Ω .
Detector Threshold: 1V

MILLIVOLTS

Measuring Range: $\pm 0,1\text{mV}$ to $\pm 1999\text{mV}$ (0 to 1000mV on analogue scale)
Accuracy: 0,1mV to 10mV d.c. or a.c. (50/60Hz) $\pm 2\%$ ± 5 digits
10mV to 1999mV d.c. or a.c. (50/60Hz) $\pm 2\%$ ± 3 digits
0,1mV to 10mV a.c. (16-460Hz) $\pm 5\%$ ± 7 digits
10mV to 1999mV a.c. (16-460 Hz) $\pm 5\%$ ± 5 digits
d.c. milliVolts zeroing: Up to 9,9mV
Input resistance: $>3\text{M}\Omega$

CAPACITANCE

Measuring Range: 0,1nF to 9,99 μF
Accuracy: $\pm 3\%$ ± 2 digits $\pm 0,2\text{nF}$
 μF zeroing: Up to 10nF

MILLI-AMPS

Measuring Range: 0,1mA to 500mA (0 to 1000mA on analogue scale)
Accuracy: 0,1mA to 10mA d.c. or a.c. (50/60 Hz) $\pm 2\%$ ± 5 digits
10mA to 500mA d.c. or a.c. (50/60 Hz) $\pm 2\%$ ± 3 digits
0,1mA to 10mA a.c. (16-460 Hz) $\pm 5\%$ ± 7 digits
10mA to 500mA a.c. (16-460 Hz) $\pm 5\%$ ± 5 digits

FREQUENCY

Measuring range: 16Hz to 460Hz
Accuracy: $\pm 1\%$ ± 1 digit

Basic and service errors for Insulation and Resistance ranges.

The basic error is the maximum inaccuracy of the instrument under ideal conditions, whereas the service error is the maximum inaccuracy taking into effect of battery voltage, temperature, interference, and system voltage and frequency, where applicable. After determining the service error, we can then calculate the measurement range. This is the range of measurement over which the error in service is less than 30% of the reading. Digital instruments are affected by the number of digits error – for example a value $0,10\Omega$ measured with the continuity range may give a display in the range $0,07\Omega$ to $0,13\Omega$ which is a maximum error of 30%. Therefore the measurement range measuring low resistance is $0,10\Omega$ to $99,9\Omega$. When checking that a measurement does not exceed a limit, the service error needs to be taken into account and these tables enable this to be done quickly and easily. These will guarantee that the value being measured is greater than or less than the limit value specified as appropriate.

Insulation Resistance – $M\Omega$

Limit	Min. Indicated Reading	Limit	Min. Indicated Reading
0,10	0,14	2,00	2,12
0,20	0,25	3,00	3,16
0,30	0,35	4,00	4,20
0,40	0,46	5,00	5,24
0,50	0,56	10,00	10,8
0,60	0,66	20,00	21,2
0,70	0,77	30,00	31,6
0,80	0,87	40,00	42,0
0,90	0,98	50,00	52,4
1,00	1,08	100,00	94,0

Continuity Resistance – Ω

Limit	Max. Indicated Reading	Limit	Max. Indicated Reading
0,10	0,06	2,00	1,88
0,20	0,15	3,00	2,84
0,30	0,25	4,00	3,80
0,40	0,34	5,00	4,76
0,50	0,44	10,00	9,56
0,60	0,54	20,00	18,8
0,70	0,63	30,00	28,4
0,80	0,73	40,00	38,0
0,90	0,82	50,00	47,6
1,00	0,92	100,00	92,0

SAFETY

The instruments meet the requirements for double insulation to IEC 1010-1 (1995), EN 61010-1 (1995) to Category III*, 300 Volts phase to earth (ground) and 440 Volts phase to phase, without the need for separately fused test leads. If required, fused test leads are available as an optional accessory.

* Relates to the transient over-voltages likely to be met in fixed wiring installations.

Complies with the following parts of EN61557, Electrical safety in low voltage systems up to 1000V a.c. and 1500V d.c. – Equipment for testing, measuring or monitoring of protective measures:-

- Part 1 - General requirements
- Part 2 - Insulation resistance
- Part 4 - Resistance of earth connection and equipotential bonding

FUSE

500mA 500V, 32x 6mm Ceramic HBC 10kA minimum.

E.M.C.

The instruments meet 61326-1

POWER SUPPLY

Battery Type: 6x1,5V Alkaline cells
IEC LR6 type or 1.2V NiCd re-chargeable cells.

Battery Life (typical): 2100 5-sec 1kV insulation tests
3200 5-sec 500V insulation tests
4000 5-sec 250V insulation tests
2700 5-sec continuity tests
4700 5-sec k Ω tests

ENVIRONMENTAL CONDITIONS

Operating range: -5 to +40°C
Operating humidity: 90% RH at 40°C max.
Storage temperature range: -25 to +65°C
Calibration Temperature: +20°C
Maximum altitude: 2000m
Dust and water protection: IP54
Temperature coefficient: <0,1% per °C
WEIGHT: 742g
DIMENSIONS: 110mm x 220mm x 45mm
CLEANING: Wipe with a clean cloth dampened with soapy water or Isopropyl Alcohol (IPA)

ACCESSORIES

Supplied:	Part Number
Test lead set	6220-437
Test-&-carry case	6420-112

Optional:	Part Number
Fused lead set, FPK8	6111-218
Switch Test Probe SP6F	6220-836
Test Record Cards (Pack of 20)	6111-216
PowerSuite	6111-237
NiceOne	6111-403
9-way Serial Lead	25955-025

Publications:	
'A Stitch in Time'	AVTM21-P8B
'Testing Electrical Installations'	6231-605

Repair and Warranty

The instrument circuit contains static sensitive devices, and care must be taken in handling the printed circuit board. If the protection of an instrument has been impaired it should not be used, and be sent for repair by suitably trained and qualified personnel. The protection is likely to be impaired if, for example, the instrument shows visible damage, fails to perform the intended measurements, has been subjected to prolonged storage under unfavourable conditions, or has been exposed to severe transport stresses.

New Instruments are Guaranteed for 3 Years from the Date of Purchase by the User.

Note: Any unauthorized prior repair or adjustment will automatically invalidate the Warranty.

Instrument Repair and Spare Parts

For service requirements for Megger Instruments contact:-

Megger Limited	or	Megger
Archcliffe Road		Valley Forge Corporate Center
Dover		2621 Van Buren Avenue
Kent, CT17 9EN.		Norristown, PA 19403
England.		U.S.A.
Tel: +44 (0) 1304 502243	Tel: +1 (610) 676-8579	
Fax: +44 (0) 1304 207342	Fax: +1 (610) 676-8625	

or an approved repair company.

Approved Repair Companies

A number of independent instrument repair companies have been authorised for repair work on most Megger instruments, using genuine Megger spare parts. Consult the Appointed Distributor/Agent regarding spare parts, repair facilities, and advice on the best course of action to take.

Returning an Instrument for Repair

If returning an instrument to the manufacturer for repair, it should be sent freight pre-paid to the appropriate address. A copy of the invoice and of the packing note should be sent simultaneously by airmail to expedite clearance through Customs. A repair estimate showing freight return and other charges will be submitted to the sender, if required, before work on the instrument commences.