



Professional wireless communication system solution supplier



FP460

Service Manual

Content

Chapter 1 Overview.....	1
Chapter 2 External View and Functional Keys	3
Chapter3 Circuit Description.....	7
Chapter 4 Function Description and Parameter Settings	17
Chapter 5 Disassembly for Repair	25
Chapter 6 Adjustment	32
Chapter7 Major Specification.....	33
Chapter 8 Service and Test Equipment.....	34
Chapter 9 Troubleshooting	35
Appendix1 Abbreviation	36
Appendix 2 Electronic Parts List	37
Appendix 3 Spare Parts List (Structure Part).....	44
Appendix 4 Accessories reference List	47
Figure1 FP460 Schematic Pane Diagram.....	47
Figure2 FP460 Top Board Position Mark Diagram	51
Figure3 FP460 Bottom Board Position Mark Diagram	52

Chapter 1 Overview

1.1 Introduction

This manual applies to the service and maintenance of FP460 FM portable radios, and is intended for use by engineers and professional technicians that have been trained by Kirisun. It contains all the required service information for the equipment. Kirisun reserves the right to modify the product structure and specifications without notice in order to enhance product performance and quality. You can also contact your local dealer or us to get the latest service manual.

Please read this manual before repairing the product.

1.2 Safety Precautions

* Electromagnetic Energy Exposure

Radios will generate and radiate electromagnetic energy during transmit mode.

Kirisun radio is designed to comply with a number of national and international standards for human exposure to radio frequency electromagnetic energy.

In order to obtain best performance, and to guarantee that the electromagnetic radiation does no harm to you, always keep the radio in a vertical position to the ground

and make sure that the microphone is 2-5cm from your mouth while using.

* **Electromagnetic Interference**

In order to avoid electromagnetic interference, please turn off the radio in the place where such post prompts you to do so, e.g. hospital, health care center, airport and etc.

* **Explosive Atmosphere**

It's prohibited to use the radio in the following places:

Any area with a potentially explosive atmosphere, e.g. **orlop** deck of the ship, storage and transportation equipment for fuel and chemical, where the air with chemical substance, particle or iron dust.

Any place near blasting sites or area with electrical blasting cap.

It is also prohibited to change or charge the battery in any area with a potentially explosive atmosphere.

* **Antenna**

If the antenna has been damaged, do not use the radio. Damaged antenna may cause light burning to skin.

* **Replacement Parts**

All components used for repair should be supplied by Kirisun.

Components of the same type available on the market are not surely able to be used in this product and we do not guarantee the quality of the product using such components.

1.3 Service

All the Kirisun products are subject to the service warranty.

The warranty of the host is 18 months. The warranty of the accessories, including battery, charger, earphone, antenna and adapter, is 6 months. However, in one of the following cases, charge free service will not be available.

* No valid warranty card or original invoice.

* Malfunction caused by disassembling, repairing or reconstructing the radio by users without permission.

* Wear and tear or any man-made damage such as mechanical damage, burning or water leaking.

* Product's serial number has been damaged or the product trademark is difficult to

identify.

After the warranty expires, lifetime service is still available. We also provide service components to service stations and staffs.

Chapter 2 External View and Functional Keys

2.1 External View and Functional Keys

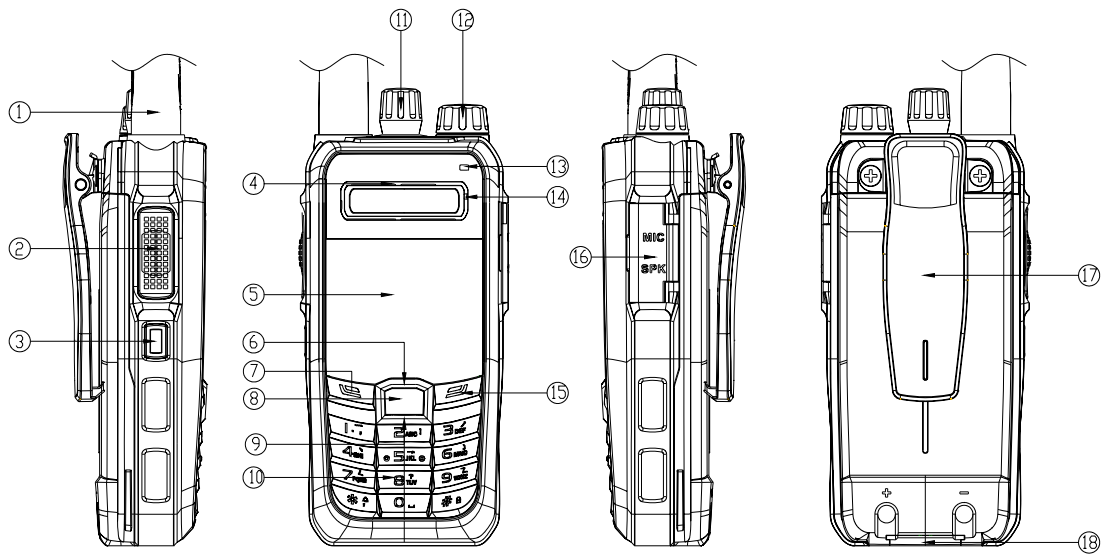

Figure 2.1

1. Antenna

2. PTT

Press the key and talk to make a call; release the key to listen

3. PF Button

The button can be assigned different functions through PC software by your dealer.

Details refer to the following “Programmable Key” in this service manual.

4. Speaker

Output the voice

5. LCD Display Screen

Display and indicate the operation status. Details refer to the following “LCD Display Screen” in this instruction.

6. Up Key

7. Menu Key

In standby status, press the key to enter the menu. In menu operation, press the key to

confirm the selected item.

8. Confirmation Key

9. Down Key

10. Digital Keypad

There are 12 keys. You can use them to enter the numbers you want to dial, edit the message or edit the contact.

11. Channel Knob

Rotate to choose 1—16 channels.

12. On/Off Key and Volume Knob

Clockwise rotate the knob to turn on the radio, and counterwise rotate the knob until there is a click sound to turn off the radio.

Rotate the knob to adjust the volume when the radio is on.

13. LED Indicator

When transmitting signal it indicates red, when receiving signal it indicates green. It flashes when the power is not enough.

14. Microphone

Input the voice

15. Cancel Key

In menu operation, press the key to cancel the operation or return back to the previous menu.

16. External Connector

Open the cover to connect external speaker and microphone.

17. Belt Clip

Pushing Buckle

2.2 Functional Keys Operation Instruction

Programmable Keys

Below keys can be set through PC software by dealers:

Long press key and short press key can be set: PFkey

Long press key can be set: Menu Key/ Cancel Key

NOTE:

Short press: Press down and release instantly.

Long press: Press down and keep 2 minutes to release.

Available functions to be chosen:

None: No feature will be assigned.

Home screen: Returns to the Home Screen in menu status.

Power level adjustment: Switch between high/low power

Call log: Enter into call log menu.

Monitor: If the current analog channel is with CTCSS/CDCSS, press the key to squelch mode to cancel the CTCSS/CDCSS function. Press the key again to return to the original status.

Emergency alarm open: Start the Emergency Alarm function to seek help.

Emergency alarm close: Exit the Emergency Alarm function.

Keypad Lock: To switch between lock and unlock status. When the keypad is locked, only PTT/ Emergency Alarm shortcut key and channel knob are available for use.

Squelch open/close: Open/close the squelch function to receive weak signal on analog channels.

Squelch level adjustment: To adjust the signal strength.

Contact list: To enter into the contact list interface to choose the number.

Scan: Check activity of other channels. Press the key to open/close this function.

Temporarily delete unwanted channel: Temporarily delete unwanted channel while scanning.

Kill: To make other radio unusable.

Unkill: To make the killed radio resume working.







Whisper: When the whisper function is on, others can hear clearly even speaking in a low voice.











Battery level indication: To indicate the left power.

Zone up: Switch to the previous zone.

Zone down: Switch to the next zone.

2.3 LCD Display Screen

Signal Strength		No signal
Indication		Signal detected.
Message		There is unread message in the inbox.
		The inbox is full.
Scan		The radio is in scanning status.
Power		The transmission power of the current channel is low.
		The transmission power of the current

		channel is high.
Keypad Lock		Indicate that the Keypad is locked.
Squelch off		Display when pressing the Squelch on/off shortcut key.
Emergency Alarm		The radio is in emergency alarm status (except secret alarm), or receives emergency alarm.
Battery Display		Indicate the residual capacity of the battery
Private Call		Indicate the current number is private call number
Group Call		Indicate the current number is group call number
All Call		Indicate the current number is all call number
Call Out		Indicate that the radio is transmitting signal.
Call In		Indicate that the radio is receiving signal.
Hold on the call		Indicate that the call is holding on, without the need to redial.

2.4 LED Indicator

Red LED lights on: the radio is transmitting.

Green LED lights on: the radio is receiving.

Red LED flashes: low battery, the battery needs to be charged.

2.5 Basic Operation

Turn On/Off the radio

Clockwise rotate the knob to turn on the radio, and counter wise rotate the knob until there is a click sound to turn off the radio.

Selecting a channel

Each channel in your radio can be programmed to analog channel or digital channel. Under the Home Screen, turn the Channel Knob to select a channel.

Adjust the volume

Rotate the knob to adjust the volume when the radio is on.

Make a call

On a digital channel, choose one of the following procedures to make a call:

- a. Enter Contacts menu, select one contact and then press and hold the PTT Button, speak to the MIC.
- b. Enter Call Log menu, and then enter Call Out or Call In item, select one contact, press the PTT Button and speak to the MIC.
- c. Under the Home Screen, press the PTT Button and speak to the MIC. The call out number is the default contact number of this channel, which can be programmed by the dealer, or set through menu.
- d. Under the Home Screen, input the number manually, then press the PTT Button and speak to the MIC.

On an analog channel, press the PTT Button and speak to the MIC.

Receiving a call

When receiving the signal, the signal strength will be indicated on LCD. While on digital channels, when receiving private call/group call/all call, the radio will output the voice. While on the analog channels, when receiving analog signal and the CTCSS/CDCSS matches, the radio will output the voice.

Answering a call

While using digital channels, press PTT within call holding time after receiving the call to answer the call. If you didn't answer back during call holding time, you should start a new call to call back. The call holding time can be set through PC software by dealers.

While using analog channels, press PTT to answer the call directly.

Chapter3 Circuit Description

3.1 Preface

This radio is FM portable radio equipment.

3.2 Frequency Configuration

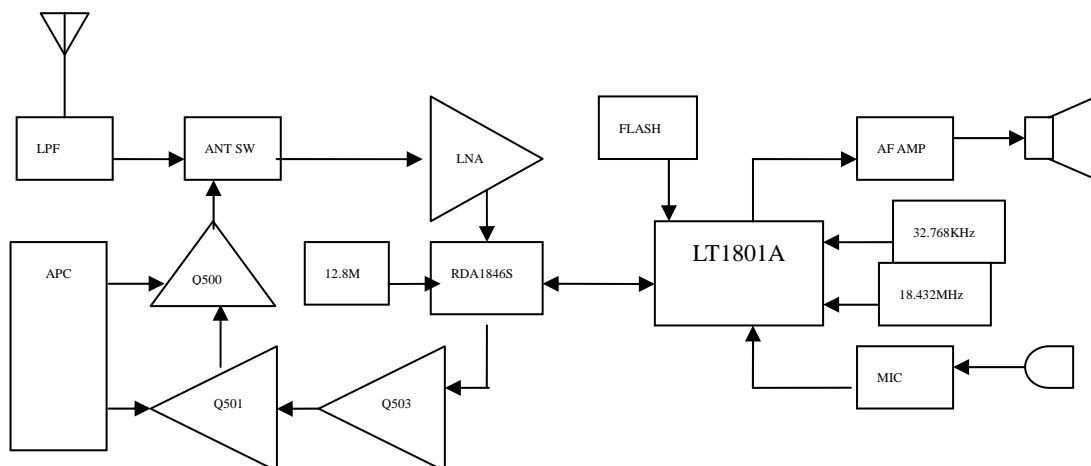

The reference frequency of RD1846S is generated by 12.8MHz crystal oscillator X500 TCXO.

3.3 Principle of Receiver (RX)

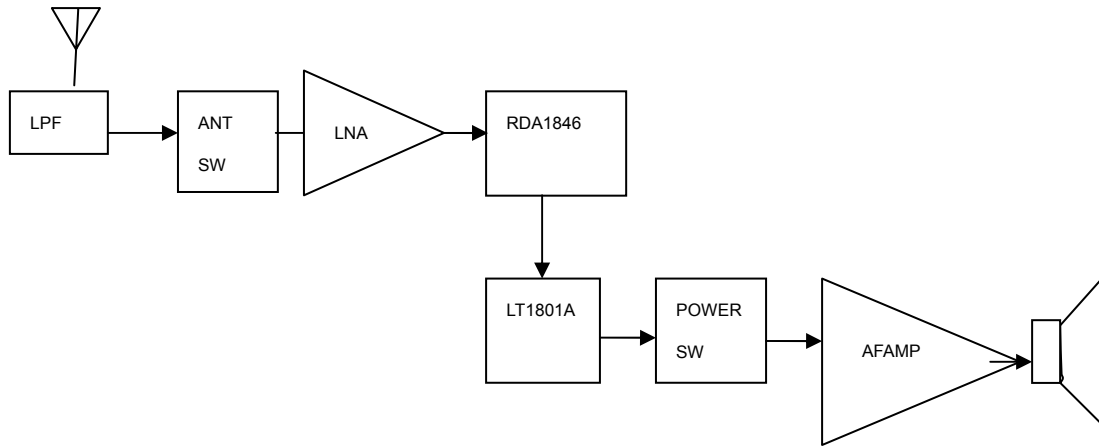

Figure 3.3 Principle of Receiver

Receiver is mainly used in receiving, selecting, amplifying, transforming, demodulating etc. and other processing like audio signal amplifying, filtering. Audio part mainly is used to post emphasis, amplify and filter audio signal.

Receiver Front End

Low noise amplifier is located in the receiver front-end, mainly used in amplifying small radio frequency signal, in order to provide certain intensity and SNR of RF signal for subsequent signal processing.

Signals from the antenna transmission (RX/TX) switch (D502 D501, D503, D504), are sent to Q507 3SK318 and peripheral components consisting of low noise amplifier (LNA) for enlarging. The enlarged signal will be sent into IC4 (RDA1846S) to demodulate into output audio signal. 3sk318 noise coefficient is 1.4 db, G about 18 db.

There is input and output match for LNA. Input match adopts best noise figure while output use maximum power to match, i.e., the amplifier output impedance adjusted to the load impedance (typically 50 ohm); Input and output impedance of the low noise pipe is usually high impedance, so the matching circuit using inverted L

Receiver audio signal processing

Audio signal from IC4 (RDA1846S) processed through LT1801, then through the volume potentiometer, to the audio power amplifier U600 (TDA2822).

Audio power amplifier

U600 and peripheral components makes up the audio power amplifier circuit

Q601 base is the control end. High level: U2 begins to make audio; Low level: closed.

Receive audio signals, voice signals, alarm sound signals are summarized and sent to speaker through audio power amplifier. Among them, the alarm sound will not be limited by volume control. The speaker impedance: 16 ohms.

3.4 Principle of Transmitter (TX)

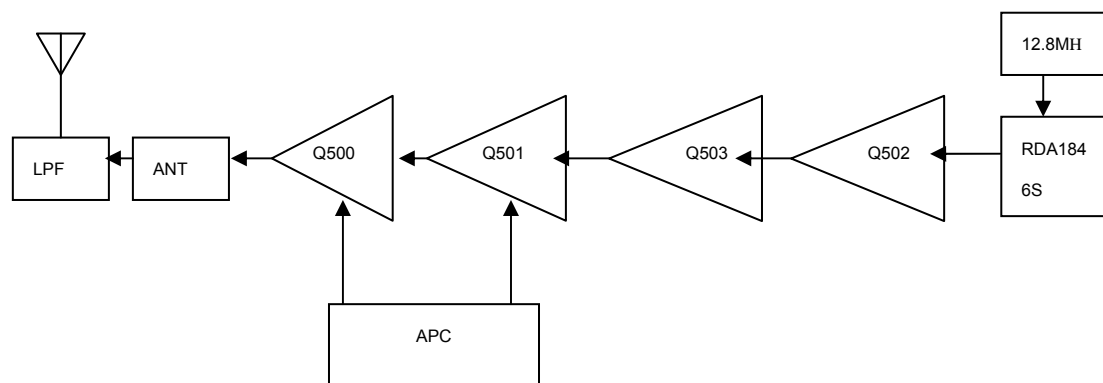

Power amplifier and antenna switch principle diagram

Modulated signal from IC4 (RDA1846S), enlarged via Q502, Q503, Q501, are sent to Q500 power amplifier, and then transmitted through receiving toggle sending into the low pass filter. LPF will improve as much as possible to harmonic stray signal attenuation in certain condition of fluctuations in performance. Q500 output power: 4W

Q502 2sc5108 pre-amplifier, mainly to preliminary enlarge output RF signal of RDA1846S, to provide a certain intensity of the amplifier after excitation signal.

Q503 2sc3356 pre-push RF amplifier is mainly used to provide a certain level of intensity of excitation signal for subsequent amplifier, so as to guarantee the driving amplifier can output enough power, to push the last stage power amplifier.

Q501 RD01 promote RF amplifier, is mainly used to promote the last stage power amplifier, to ensure the output power of the last stage power amplifier to achieve the rated

output power of the transmitter. The output is about 0.5 W, G about 14 db.

Q500 RD07, end RF power amplifier, is part of the important and critical level. The output power and efficiency level at the end power amplifier are almost equal to transmitter output power and efficiency. The stability of the last stage amplifier basically represents the stability of the transmitter also. Output is 0.8W, G about 12db.

Q500 Q501 grid bias is controlled by APC circuit. Change the gate bias voltage, can easily control the size of the transmitter output power.

APC (automatic power control) circuit

This circuit changes the gate bias voltage by testing the change of the input to the power amplifier drain current and changes the output power by changing the gain.

R520 R521, R522 are power amplifier current detection, U502A is the current sampling amplifier power amplifier. U502B is the comparison power amplifier.

If the transmitter output power is too large, the power amplifier current increase, U502A output rise, U502B output voltage drops, applied to Q500, Q501 bias voltage to drop, lower the transmitter output power, vice versa. In this way, the transmitter output power is stable under different working conditions.

MCU achieves the goal of setting power by changing the input to the voltage on the U502B.

Transmitter speech signal processing

MIC signal is sent through the inside and outside MIC switch circuit into No. 11 feet of IC4 (RDA1846S) to modulate the carrier.

3.5 Principle of power

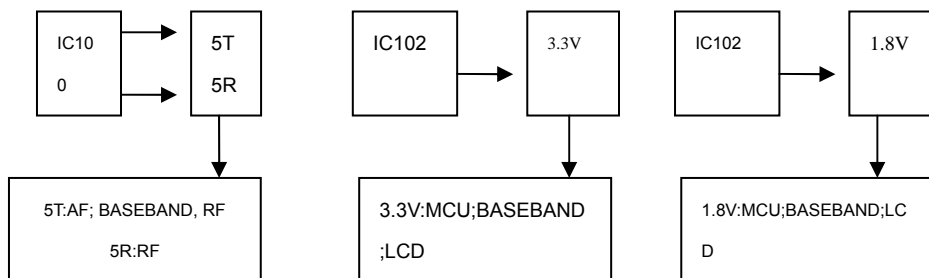

The machine uses 7.4 V batteries. Transmitter power amplifier circuit (Q500, Q501) and receiver audio processing (U600) directly uses the battery. All the other circuits are powered by constant 5 V power supply.

IC100: 5T switch, controlled by MCU.

5T: supply power for front-end transmitter

5 R: supply power for receiver RF amplifier, audio signal processing unit

etc.

IC102:3C switch controlled by MCU, Provide 3.3 V

3C: receive 3V electricity controlled by power save, supply power for RDA1846S.

IC102: Provide VCC1.8V

3.6 IC characteristics

RDA1846S features:

3.6.1. Fully integrated CMOS RF front-end

3.6.2, High linearity and low noise amplifier and mixer

3.6.3. Low intermediate frequency receiving channel

Automatic DC offset calibration circuit

High performance analog/digital converter and digital/analog converter

Fully integrated receive filters

The digital AGC

The frequency modulation demodulation technology based on digital signal processing technology

3.6.4 Direct frequency synthesis pathway

Direct frequency synthesis frequency modulation

Emission filter based on digital signal processing technology

FM digital gain adjustable

Digital voice activation emission control

3.6.5. High-performance decimal PLL frequency synthesizers

Complete piece RF VCO

The complete piece inside the loop filter

- Low phase noise
- Extremely fast phase lock time
- High frequency resolution, frequency is adjustable
- The built-in crystal frequency error calibration circuit
- 3.6.6. Ultra low power sleep mode
- 3.6.7. Three line serial digital interface control

3.7 semiconductor devices

MCU instructions

Table 3.7 the microprocessor (LT1801A) port

Pin NO	I/O	Port Name	function
E11	IO	SIRIN	SECRET_IO(Reserved for Encryption chip)
D11	IO	SIROUT	POW_C (Soft switch on power control)
M4	IO	RXD1	RXD(Download program)
J4	IO	TXD1	TXD(Download program)
L4	IO	RXD2	EFUNC1(function key)
K4	IO	TXD2	EFUNC2(function key, monitor key)
A16	IO	SCLK0	GPS Enable Pin
A15	IO	SSN0	TX_LED(Transmitter indication)
B11	IO	SRX0	RX_LED(Receiver indication)
A11	IO	STX0	LAMP(keypad light)
N4	IO	SIMCK	PTT KEY(PTT)
R4	IO	SIMIO	EXT_PTT (PTT for earpiece)
P4	IO	SIMRST	Soft boot detection (use this if you have any other functions. Otherwise, please use POW_ON
A8	IO	RFSO	RFIF Three line SPI serial data output module
E9	IO	RFSN0	RFIF Modules chosen line of three SPI piece inside signal is 0
C12	IO	AON	HEADSET_DET(headset detect)
B15	IOU	KB0	KB The keyboard scan input/output signals [0-7], includes alarm and two function keys. It is highly recommended to refer to the design the of hardware keyboard circuit to make it easier for compatibility
B14	IOU	KB1	
B13	IOU	KB2	

B12	IOU	KB3		
C16	IOU	KB4		
C15	IOU	KB5		
C14	IOU	KB6		
C13	IOU	KB7		
T3	IO	LCDCRD		LCD_RD
R3	IO	LCDCRS		LCD_RS
P3	IO	LCDCWR		LCD_WR
M3	IO	LCDCS0		LCD_CS
N3	IO	LCDCS1		LCD_RST
K1	IO	LCDC0		LCD_D0
L1	IO	LCDC1		LCD_D1
M1	IO	LCDC2		LCD_D2
A14	IO	SCLK1		SPEAKER_POP/AGC_PD (AGC enable chip)
B16	IO	SSN1		APC
A13	IO	SRX1		
A12	IO	STX1		RX_SW
A9	IO	PWM0		MOTO_EN 或 LAMP(Keypad light)
E10	IO	PWM1		LCD_BACK
E7	-	GPO0		P_UL (Indicate frequency lock state)
D7		GPO1		5T (TX power control)
C7		GPO2		5R (RX power control)
B7		GPO3		5C (Radio frequency (RF) public power control)
				CPU please don't use these 4 pins
D9	IO	RFSN1		P_PS (PLL lock indicator)
C9	IO	RFSN2		TX-SW
B5	IO	OSCEN		SPEAKER_EN
B8	IO	RFCLK		RFIF (Three line SPI clock module)
P6	IO			NC
N1	IO	LCDC3		LCD_D3
P1	IO	LCDC4		LCD_D4
R1	IO	LCDC5		LCD_D5
T1	IO	LCDC6		LCD_D6
K2	IO	LCDC7		LCD_D7
L2	IO	LCDC8		LCD_D8
M2	IO	LCDC9		LCD_D9
N2	IO	LCDC10		LCD_D10
P2	IO	LCDC11		LCD_D11
R2	IO	LCDC12		LCD_D12
T2	IO	LCDC13		LCD_D13

K3	IO	LCDC14		LCD_D14
L3	IO	LCDC15		LCD_D15
G3	AI		Simulation of the ADC module voltage input range is 0 to 3 v	VO or VOX
F3	AI			battery voltage detection
E3	AI			RSSI
D3	AI			BUSY
F5	AO	RFIF (AUXDA)	Simulation of DAC module input voltage range of 1.15-2.15 V	VCCN(TCXO reference voltage)
E5	AO	RFIF (AUXDA)	Simulation of DAC module voltage input range is 0 to 3 v	TV/PC
D1	AI	RX_I+	Simulation of the ADC module for single-ended input voltage range 1 VPP, difference of 2, pp	AFDET
C1	AI	RX_I-		
B1	AI	RX_Q+	Simulation of the ADC module for single-ended input voltage range 1 VPP, difference of 2, pp	
A1	AI	RX_Q-		
A2	IO	TX_I+	Simulation of DAC module voltage output range of single-ended 1 VPP, difference 2 VPP	MOD1
B2	IO	TX_I-		
A4	IO	TX_Q+	Simulation of DAC module voltage output range of single-ended 1 VPP, difference 2 VPP	MOD2
B4	IO	TX_Q-		
G2	IO		CODEC 16 Ohm 耳机 headphones negative output	CODEC 16 Ohm Headphones differential negative output
H2	IO		CODEC 16 Ohm headphones positive output	CODEC 16 Ohm Headphones difference negative output
H5	IO		CODEC The microphone bias voltage	MIXBIAS
J2	IO		SPEAKER Linear	SPEAKER Linear output

			output	
E2	AI		MIC input input amplitude=96mv when 24dB open; input amplitude=1.53V after closed	MIC2(headphone MIC input)
F2	AI		MIC input input amplitude=96mv when 24dB open; input amplitude=1.53V after closed	MIC1(headphone MIC input)
L5				
D10				RXD0 (for GPS)
C10				TXD0 (for GPS)
B10				RTS0 (for GPS)
A10				CTS0 (for GPS)
R5				
K5				GPIO0_12 Hard boot detection
L7				
L8				
L9				
L10	-			

RDA1846S port

AVDD	1	Power supply
SCLK	2	Clock input for serial control bus
SDIO	3	Data input/output for serial control bus
AVDD	4	Power supply
XTAL1	5	Oscillator pin 1
XTAL2	6	Oscillator pin 2,control interface select
MODE	7	When MODE = V _L , I ² C Interface is select; When MODE = V _H , SPI Interface is select
SENB	8	Latch enable (active low) input for serial control bus
AFOUT	9	Audio signal output to speaker
NC*	10	No connection
MIC_IN	11	MIC input
Cc	12	Compensation capacitor connection
AVDD	13	Power supply

NC*	14	No connection
RFIN	15	RF signal input
AVDD	16	Power supply
NC*	17	No connection
RFOUT	18	RF signal output
NC*	19	No connection
NC*	20	No connection
AVDD	21	Power supply
PABIAS	22	PA bias supply for PA
AVDD	23	Power supply
PDN	24	Chip enable, high active; Chip sleep, low active
GPI07	25	Gpio7/vox(When Gpio7=V _H , vox is active; else V _L)
GPI06	26	Gpio6 / sq (When Gpio6=V _H , sq is active; else V _L)
GPI05	27	Gpio5 / txon (When Gpio5=V _H , txon is active; else V _L)
GPI04	28	Gpio4 / rxon (When Gpio4=V _H , rxon is active; else V _L)
GPI03	29	Gpio3 / sdo (Gpio3=V _H or V _L , it is the output register data in 4 wire control Interface mode)
GPI02	30	Gpio2 / int (When Gpio2=V _H , int is active; else V _L)
GPI01	31	Gpio1 / code_in / code_out (Gpio1=V _H or V _L , it is the input/output code data)
GPI00	32	Gpio0 / css_in / css_out (Gpio0=V _H or V _L , it is the input/output CTCSS/CDCSS signal)

3.8 semiconductor devices functional description

Item	Model No.	Functions
U500	NJM2904	APC,
U400	LT1801A	MCU
IC200	24LC512	E ² PROM , Storage channel frequency data, set parameters, debugging status parameters
U201	TDA2822	Receiver audio power amplifier
Q500	RD07S2B	end of TX power amplifier
Q504	DTA144EE	APC output switch
Q507	3SK318	Receiver high power
Q200	DTC144EE	Red LED drive
Q201	DTC144EE	Green LED drive

Q501	RD01MUS1	Transmitter power amplifier
Q202	DTC144EE	Audio power amplifier control switch
U404	XC6204B502MR	The adjustable 5 R, 5 T voltage output
IC102	LN2407	1.8V output voltage adjustment
IC103	LN2407	3.3V output voltage adjustment
Q600	FMMT717	Audio output control switch
Q205	DTC144EE	MIC Switch
Q501	2SC5108	TX 1 st amplifier
Q503	2SC3356	TX 2st amplifier

Chapter 4 Function Description and Parameter Settings

Press the Menu Key to enter it. The menu items would be a slight difference in digital mode and in analog mode. And the items displayed can be reprogramming by your dealer.

4.1 Menu in digital mode

If you choose a digital channel, the main menu structure is as follows:

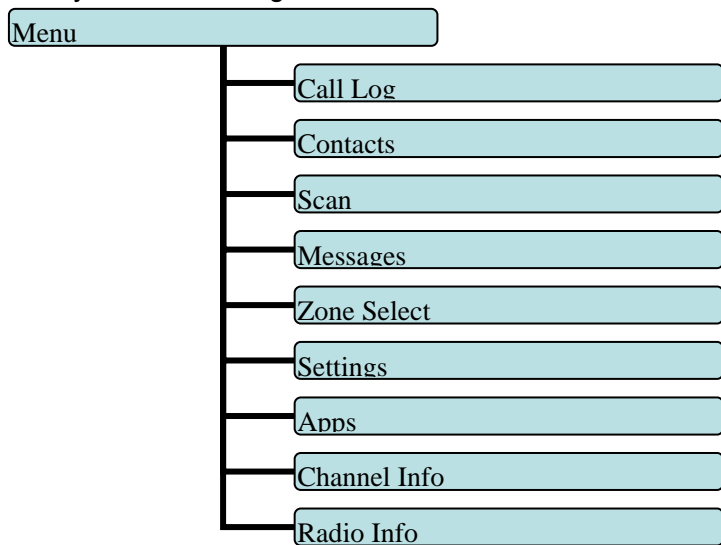

◆ Call Log

Press the Menu Key to access the main menu, then press the Up/Down Key to “Call Log” and press the “OK” key to confirm, or press the shortcut “ Call Log Key” to enter to “Call Log”.

Your radio is able to record the call in and call out log. If the call log is full, the earliest log will be covered and disappeared when the new call record is saved.

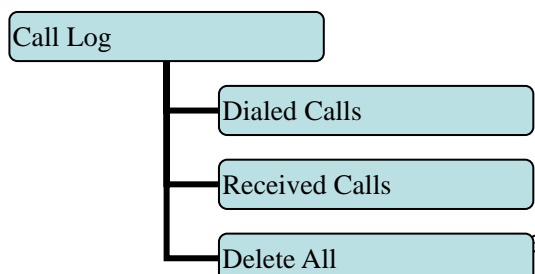

You can make a call, check the detailed information of the contact, add number, send a Status Inquire call, set the contact as the default contact, and delete the call log under these two items. If the Kill or Revive function is enabled by your dealer, you can also send Radio Enable or Radio Disable command to the contact.

You can use “delete all” to delete all the call logs, including “Dialed Calls” and “Received Calls”.

1) Detailed information:

You can view the detailed information of the selected call log.

2) Add number:

You can add the number of the selected call log into Contact list. Only Individual Call log has this function.

3) Status Inquire:

You can send this command to the selected number (only private call contact) to make sure whether the radio has been powered on or is active on the current channel secretly. Only Individual Call log has this function.

4) Kill

You can send this command to the contact (only private call contact) to make the target radio disabled.

5) Revive:

You can send this command to the killed radio (only private call contact) to make the target radio enabled.

6) Set as default contact:

The default contact is the contact number which is dialed to make a call by pressing the PTT Button directly, without the need to enter Dialed Call, Received Call or Contacts menu list. Each channel can be set one default contact. The number can be programmed by your dealer or set on your radio. Set as default contact means to set the selected number as the default contact of the current channel. Only Group Call log has this function.

7) Delete:

Delete the selected call logs.

◆ Contacts :

Press the Menu Key to access the main menu, then press the Up/Down Key to Contacts and press the OK Key to confirm.

Contact list

You can view the entire Contacts list through Contact menu or the Contact List shortcut key. These contacts can be edited by programming software or by inputting manually. Only the private call contact can be inputted manually.

Enter Contacts list, choose one contact, you can perform the following operations: press the PTT Button to send a call; check the detailed information; send a Status Inquire Call(only individual call contacts); set this contact as default contact; edit(only individual call contacts) or delete(only individual call contacts) contact. If Kill, Revive function is enabled by your dealer; you can also send Kill or Revive command to the contact.

About the descriptions of Status Inquire, Set as default contact, Kill and Revive, details refer to Call Log Section. And other functions are as below:

1)Detailed information:

You can check the contact’s name, number, and call type.

2)Edit:

You can edit the contact’s name and number.

3) Delete:

Delete the selected contact.

4) New contact :

You can create an individual call contact into the contacts list. The contact number is made up of 7 digits.

◆ Scan

Press the “Menu key” to access the main menu, then press Up/Down key to enter scan.

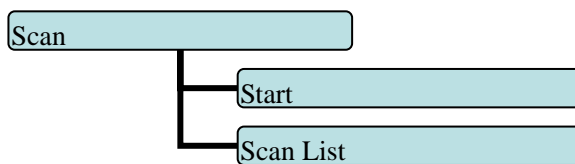

Starting Scan

Scan function helps you to receive calls from other channels, so as to supervise the activities of the personnel. Select Start item and confirm to start scanning, and press the Cancel Key or Scan shortcut key to stop scanning.

In scanning status, press the Menu Key, the following menu will be displayed:

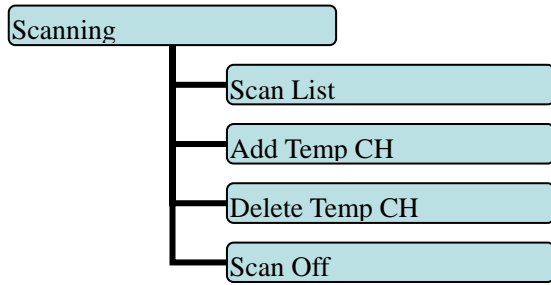

Scan List

Each channel can correspond to one scan list by dealer’s programming. Only the channel which is set in the Scan List item can enable scanning. Each scan list includes 16 channels at most, with both digital and analog channel. Selecting Scan List item and confirming it, check, added or delete the channels included in it.

Attention: If the channel included in the Scan List is changed, the other channels which related to the Scan List will be influenced.

Add/Delete Temp Channel

During scanning, if the radio stops on an unwanted channel, such as nuisance channels, the unwanted channel can be temporarily deleted by selecting Delete Temp Channel function, and then the scan continues. And also, you can temporarily add a channel by selecting Add Temp Channel function. After existing scanning mode, the temporarily added or deleted channel is invalid. The scan list resumes its original channel.

◆ Message

Press the Menu Key to access the main menu, then Press the Up/Down Key to Messages and press the OK Key to confirm.

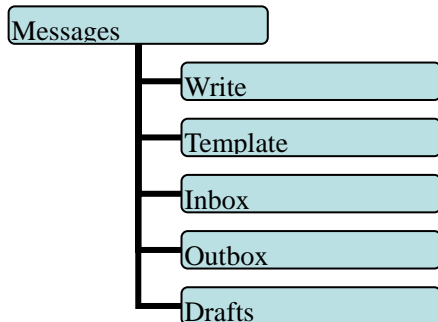

1) Writing a message

You can write a new message to send. The target contact can be chosen from the Contact List. The message can also be saved into Drafts, and the template message can be inserted while writing a new message.

2) Template

There are some template messages programmed by your dealer, you can send these message directly if you like.

3) Inbox

The inbox stores the received messages. If there's a new message, will be displayed on the home screen; if the inbox is full, will be displayed. If the inbox is full, the earliest received messages will be covered and disappeared after receiving a new message. You can check the detailed information, reply, forward and delete the message here.

4) Outbox

The outbox stores the sent messages. If the outbox is full, the earliest sent messages will be covered and disappeared after sending a new message. You can check the detailed information, resend, forward and delete the message here

5) Drafts

The draft box stores the draft messages. If the draft box is full, the earliest draft messages will be covered and disappeared after saving a new draft message. You can send, edit and delete the message here

◆ Zone

A zone is a group of channels. You radio supports up to 16 channels and 16 zones, with a maximum of 16 channels per zone. Zone can be selected by menu.

◆ Setting

You can set your radio parameters as required, including Power, Squelch Level, Whisper, Keypad Lock, Alert Tone, Home Screen, Battery Saving, Language and voice enhancement, encryption. Settings will be different due to different dealers.

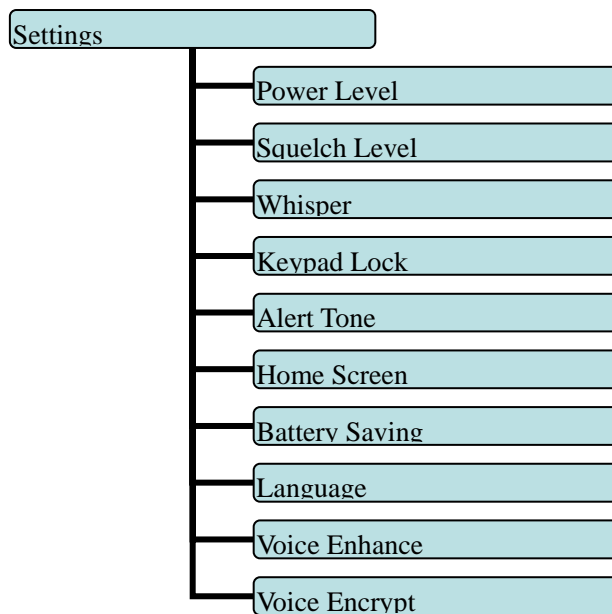

1) Power Level

The channel's power can be set as High or Low. High power is useful in long distance

communication, but the battery's working time will be lessened. **H** refers to high power, **L** refers to low power. Each channel's power level can be set separately

2) Squelch Level

The radio's squelch level can be set from 0 to 9. If the squelch level is higher, the radio is affected less by noise, but harder to receive weak signal. If the squelch level is lower, the radio is easier to receive weak signal, but easier affected by noise.

3) Whisper:

Whisper function can make the receiver hear clearly even if you speak in a low voice to MIC. You can set whisper function on/off here. The whisper can be turned on/off by menu or programming key.

4) Keypad Lock:

If the function is enabled, the keypad will be locked automatically. And only the PTT Button, Emergency Key and Keypad Lock shortcut key are available when the keypad is locked. You can set keypad lock function on/off here

5) Alert Tone

You can set alert tone function on/off the alert tone here.

6) Home Screen

You can set what to display on your Home Screen, including channel number, channel frequency, channel name, zone number and zone alias.

7) Battery Saver

You can set battery saver function on/off here. This function can prolong the battery's working time when enabled.

8) Language:

You can choose Chinese or English as the working language

9) Voice Enhancement

You can turn on/off Voice Enhancement function or set the enhancement level.

10) Voice Encryption

You can turn on/off Voice Encryption of current channel. .

◆ APPs

Calculator is available under this menu

◆ Channel Informatio

You can check the current channel mode and transmit/receive frequency.

◆ Radio Information

You can check the following information: radio ID, model type, firmware version, data version and frequency range.

4.2 Menu in analog mode

In analog channel, there are Scan, Channel Info, Settings, APPs and Radio Info in the main menu, the contents of which are the same as on digital channel. (Refer to: Menu in digital mode)

You can check the frequency and CTCSS of the current channel under Channel Info menu item.

4.3 Major Functions

4.3.1 Keypad Lock

If the keypad is locked, the keys have no reaction when pressing key except the PTT key, Emergency key, coding knob or the Keypad Lock key is pressed. Thus, it can avoid changing the current channel and working status unconsciously.

Long press the Keypad Lock shortcut key to lock the keypad, and long press this key or “*” key to unlock it.

You can turn on or off this function following these steps: “Setting” menu→”Keypad Lock” item→ select “ON” or “OFF”.

When keypad lock is on, the radio will enter keypad lock status when no operation.

4.3.2 TOT

This function forbids you from occupying the channel for a long time. If the continuous transmitting time exceeds the setting time by dealer, the radio sends out a warning tone and stops transmitting. Release the PTT key to stop the warning tone. After a period of time, which is set by dealer, you can transmit again. And if the radio is programmed with pre-alert function by the dealer, the radio will send out an alert before the time out timer expires.

4.3.3 Scan

During scan, the radio checks and stops on a busy channel. Then the radio continues scanning until the channel is not busy for a while (this time is set by dealer, which is named as Scan Hold Time).

Steps to start scanning: press the Scan shortcut key → select “Start” item. The radio scans the channels in the current scanning list one by one. During scan, press the Cancel key or scan shortcut key to stop.

◆ Scan revert channel

During scan, press the PTT key to make the radio transmit on a default channel. The channel can be programmed by your dealer.

4.3.4 Messages

Enter “Messages” menu, you can edit, send, receive, reply, forward and delete the message.

4.3.5 Shortcut Messages

Enter “Messages→Shortcut Message” menu, you can edit, send, receive, reply, forward and delete the shortcut message. The content of shortcut messages is set by local dealers. Users can use these functions under the menu prompt

4.3.6 Kill、Revive

This function allows one radio sending the signaling to kill another radio. The radio to be killed cannot display anything, make or receive calls. The radio can only revive through CPS sends a revive order. After revived, the radio can work normally again. This function is used to manage the unauthorized usage of the radio, prevent misappropriating the radio which is lost

4.3.7Emergency

If you are in danger and this function is enabled, you can press Emergency Alarm On shortcut key to send an emergency alarm.

The means of sending emergency alarm are decided by the following parameters: Alarm Type, which defines the audio and visual reaction when the radio sends an alarm; Alarm Mode, which defines the content sent to the other members when the radio sends an alarm. The above parameters can be programmed by dealer.

To turn off the Emergency Alarm, press the programmed Emergency Alarm Off shortcut key.

Alarm Type:

- ◆None: No alarm function (Default setting); you cannot send an emergency alarm.
- ◆Siren Only: The radio only emits siren locally.
- ◆Regular: The radio provides audio and visual indication that it is in Emergency mode and can receive the signal from others;
- ◆Secret: No audio and visual indication. And the radio cannot receive the signal from others;
- ◆Secret with voice to follow: No audio and visual indication. But the radio can receive the signal from others.

Alarm Mode:

◆Emergency Alarm: The radio sends out an emergency alarm, and then exits the emergency alarm status automatically.

◆Emergency Alarm w/ Call: An emergency alarm is sent, after which an emergency call can be transmitted by pressing the PTT Button.

◆Emergency Alarm w/ Voice to Follow: The radio sends out an emergency alarm, and then sends out background tone periodically and automatically through emergency call.

Note:

Emergency Alarm: The radio sends out a signal to alert other member.

Emergency Call: A priority call on channel, so as to make sure the successful communication under emergency condition.

4.3.8 Parameter Setting(PC Mode):

The radio parameter have been programmed in the factory.The user can reset the radio parameters such as working frequency, channels, digital functions, QT/DQT, and auto scanning.We designed a user-friendly and convenient programming software CPSc to set parameters on the radio. The programming steps are as following:

Install the programming software of FP460

B. Connect the radio to the computer serial port with the specified programming cable,see figure17.

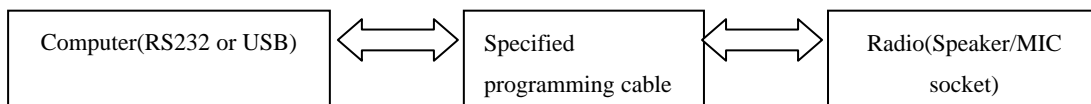

C. Turn on the radio power

D. Click the CPSc to run the programming software.

E. Click read to read the data from radio.

G. About more details, please refer to help file or programming instruction manual.

Chapter 5 Disassembly for Repair

The radio is a piece of precision communication equipment. Please be careful when disassembling the radio during service. The instructions for the disassembly are as follows.

5.1 Installing/Removing the Battery

Removing the Battery

Make sure the radio has been turned off,

When you remove the battery, ①push the battery latch upwards, ②battery will upspring, ③remove it away from the radio. ④If the radio with belt, please pull up the

battery.

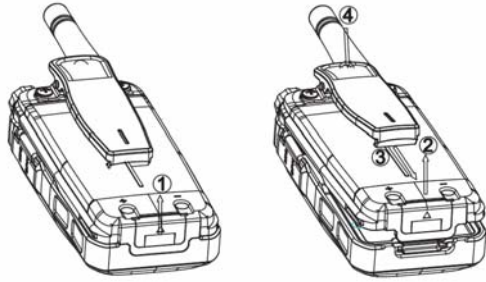

Installing the Battery

If the radio with belt, ① please upspring the belt. ② Install the two bulges at the bottom of the battery pack with the corresponding slots at the rear bottom of the radio. ③ Push the top part of the battery towards the radio to lock it until a click is heard.

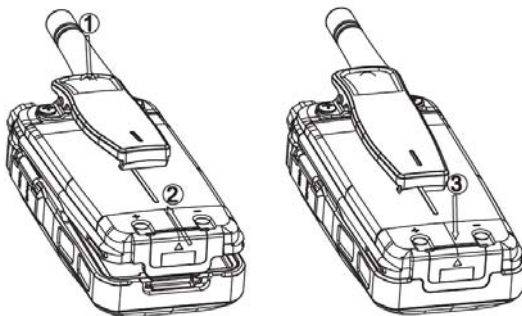

Notice:

Do not short-circuit the battery terminals or dispose of batteries in fire.

Do not attempt to disassemble the case of the battery.

5.2 Installing/Removing the Antenna

Installing: Hold the base of the antenna and turn the antenna clockwise into the connector on the top of the radio until it's tightened.

Removing: Hold the base of the antenna and turn the antenna anti-clockwise and remove it.

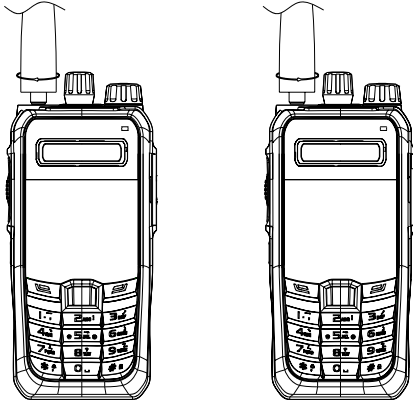

5.3 Installing/Removing the Belt Clip

Match the grooves of the belt clip to the rear top of the battery, fixed it with two 2.5x8.0 screws. Loosen the two screws fixing clip, you can remove the clip.

2.5x8.0 screws

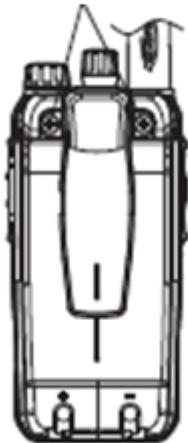

5.4 Installing an optional headset

When you use an external headset, to open outward headphones cover in the upper right of the radio, plug the external headphone cable into the headset port.

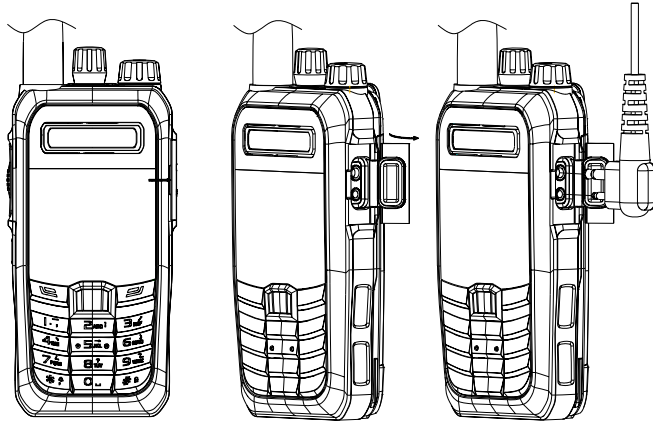

5.5 Removing the Back Cabinet from the Chassis

- (1) Remove the antenna;
- (2) Remove the knobs;
- (2) Remove two screws on the knob and the screw on the antenna;
- (3) Remove the two screws on the back cabinet;
- (4) Remove those four screws on the Al alloy bracket;
- (5) Insert the flat-bladed screwdriver into the slot of Al alloy bracket; lift it so as to separate the Zinc alloy bracket from the chassis, and then push the Al alloy bracket away from the chassis, and take the soft flat cable away from the socket. Using the soldering iron to separate the speaker connecting cable.

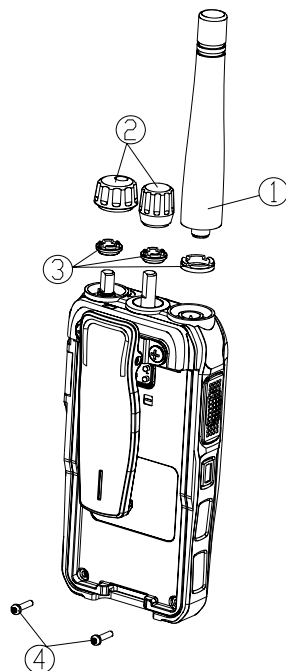

5.6 Removing the PCB Board from the Chassis

(1) Screw off screws on the main board

(2) Take down the waterproof cushion in top and use the soldering iron to cut off the antenna connecting point, and then separate the main board (include PTT PCB) from the aluminium alloy chassis.

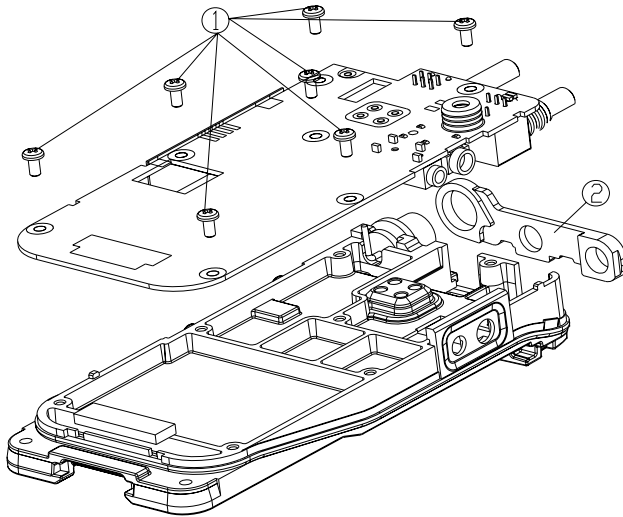

After the demolition of the above, you can make the appropriate repairs and debugging against fault conditions.

5.7 Exploded view

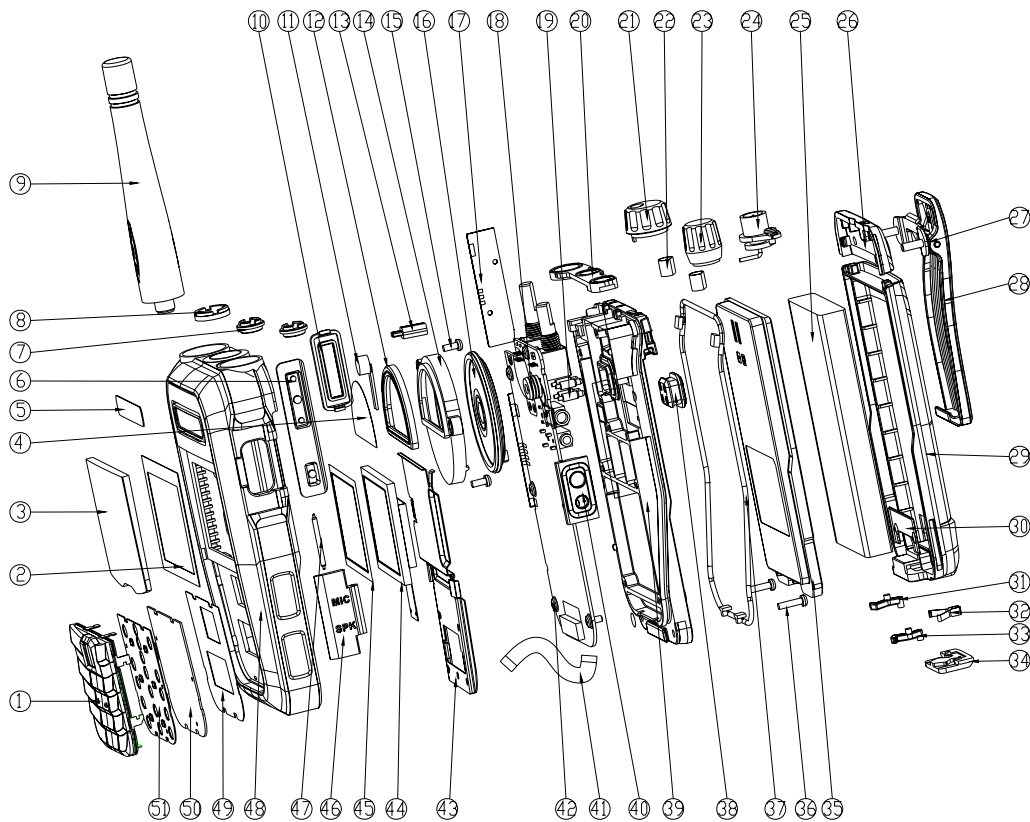

No.	Part Code	Part Name	Specifications	Unit
-----	-----------	-----------	----------------	------

1	7MHR-4038-06A-W0	FP460 Number Key	Laser carving; characters translucent;	1
2	7MHJ-4038-01A-W	FP460 Lens Adhesive	3M9448;Xinlongda;	1
3	7MHP-4038-02A-WC	FP460 lens	PC, Transparent high-gloss, silk screen, with 40mm speaker	1
4	7GCB-S4038-01A	FP460 speaker cover	Nylon mesh; shaped, black; Xinlongda; non-lead	1
5	7PLJ-4038-E01A	FP460 Trademark stickers	Transparent PC	1
6	7MHR-4038-01A-W0	FP460 Side silicone key	Silica gel; black; Laser carving PT Orange21C;	1
7	7NRC-060090035-W1	FP460 Coding nut	Brass, diameter M6mm, OD ϕ 9mm, thick 3.5mm, black nickel plated	2
8	7NRC-090115025-G1	3208 nut	Brass, diameter M9mm, OD ϕ 11.5mm, thickness 2.5mm, gold plated	1
9	8ATX-400470-WU	FP460 Antenna	428649, Φ =40mm,H=4.5mm	1
10	7MHP-4038-05A-W0	FP460 PTT cover	Double color	1
11		MIC	Φ 6, Stripline	1
12	7MBR-4038-02A-W0	FP460 Speaker silicone pad	Silica gel; Black	1
13	7MHR-4038-04A-WC	FP460 Light pipe	Silica gel; transparent; high light; With 40mm speakers	1
14	7MHP-4038-12A-W0	FP460 Speaker stand	ABS, Black	1
15		Screw	ST2*5.5, Rolled flat end, black	2
16	4SS7-4005-016-100C	Speaker	Φ 40, Impedance 16 Ω , power 1W	1
17	7MHS-4038-02A-W	PTT keypad metal dome	ϕ 5mm,SUS301 Round metal dome	1
18	7MHR-1727-09A-W3	558 radio mic sets	Silica, hardness 40, orange, no surface treatment	1
19	7MDC-4057-02A-G	FP460 Battery SLC	Material: Brass; nickel-plated gold-covered	4
20	7MHR-4038-04A-W0	FP460 Top waterproof pad	Silica gel; black; polishing	1
21	7MHP-4038-03A-W0	FP460 Volume knob	ABS; Black; texture, white-oil	1
22	7MHS-1140-01A-W	Knob retainer	Spring steel	2
23	7MHP-4038-04A-W0	FP460 Coding knob	ABS; Black; texture, white-oil	1

24	3CR7-SMA-50JF-4	RF coaxial connectors	SMA-J, Flange mounting, used for 7200	1
25	6BPM-784043-07415 0-A	Li-poly battery pack	Li-poly battery pack 78mm*40mm*4.3mm×2,7.4V,1500mAh	1
26	7MHP-4038-02A-W0	FP460 Cover	PC+ABS; Black; texture	1
27	7SMF-020080M-MH HT-N1	M2*8 Plum-type Thick Head Machine Screw	Iron and hard, Φ2mm * 8mm thick plum-type nickel-plated machine Metric Coarse, drop-resistant treatment	2
28	6SS3-BJ4038-A	KBJ-17 Belt		1
29	7MDP-4057-01A-W0	KB-460 Battery top shell	PC+ABS; Black; texture	1
30	6PD7-4057-DPA	KB-460 Battery charging board	PCB,29.4X11.3MM, Thickness: 0.6MM, 2 layers	1
31	7MHP-4038-10B-W0	FP460 Power on Right hook	POM; Black; high light	1
32	7MHC-4038-01B-Z	FP460 Power on splinter	Imports of stainless steel, 0.3mm	1
33	7MHP-4038-09B-W0	FP460 Power on left hook	POM; Black; high light	1
34	7MHP-4038-08B-W0	FP460 Power on Push Button	PC+ABS; Black; texture	1
35	7MDP-4057-02A-W0	KB-460 Battery case back	PC+ABS; Black; texture	1
36	7SMF-020080M-MH HT-N1	M2*8 Plum-type Thick Head Machine Screw	Iron and hard, Φ2mm * 8mm thick plum-type nickel-plated machine Metric Coarse, drop-resistant treatment	1
37	7MHR-4038-02A-W0	FP460 main Waterproof gasket	Silica gel; black; high gloss	1
38	7MHR-4038-05A-W0	FP460 Bomb-pin socket	Silica gel; black; polishing	1
39	7MHL-4038-01A-W	FP460 Aluminum	ADC12;	1
40	7MHP-4038-07A-W0	FP460 Headphone jack waterproof pad	TPU; Black; texture	1
41	3WF7-05030-500C4	Flexible cable	Pitch 0.5mm, 30P, Cord Length 50cm, Tip Length 3mm, reinforced 4mm, double-sided in the same direction	1
42	7SMF-020080M-MH HT-N1	M2*4 Cross round flat head Machine	Iron and hard,Φ2mm*4mm Cross round flat head	8

		Screw	Nickel-plated machine, Metric Coarse, plus drop-resistant treatment	
43	7MHS-4038-04A-W	FP460LCD Stand with shield	Imports of stainless steel, 0.3mm Thick	1
44	4PC7-4038H-A	FP460 LCD screen	Imitation translucent, horizontal with vertical screen, backlit 42.7mm high, ZhongYiWei, non-lead	1
45	7MHM-4038-02A-W9	FP460LCD Foam pad	T=0.5mm Sponge; black; sided adhesive and PET liner	1
46	7MHP-4038-06A-W0	FP460 Headphone cover	TPU; Black; texture	1
47	7MJS-4038-01A-W0	FP460 spindle	SUS304; Natural color	1
48	7MHP-4038-11A-W0	FP460 Surface shell	PC+ABS; Black; texture	1
49	7MHJ-4038-02A-W	FP460 Key board backing	3M9448	1
50	6SS1-4038-HKA	FP460 Key board	PCB parts	1
51	7MHS-4038-01A-W	FP460 digital keypad metal dome	φ4mm,SUS301 round metal dome;waterproof	1

Chapter 6 Adjustment

6.1 Method of Adjustment

During the servicing, it is necessary to test and adjust the radio's technical parameters after changing components.

6.1.1 Components needed for the adjustment

- (1) Antenna connector converter
- (2) Universal connector

6.1.2 Adjustment Method in PC Testing Mode

Tx Part

A. Tx Frequency

The Tx frequency is the standard frequency \pm 100Hz.

B. Power

- a. High Power is 3.5-5.0W.
- b. Low Power is 0.5-1.5W.

C. Voltage

Voltage is 6.5V.

Rx Part

A. Max Volume

Set RF of the comprehensive tester to be the center frequency, the single strength to be 1mV and the modulation deviation to be 3.0kHz/1.5kHz (wide/narrow band), and then in PC mode, adjust the value of “Max. Volume” to make the audio power to be 1.0-1.2W.

B. Squelch

a. Set the RF signal of the comprehensive tester to be -121dBm, and the deviation 3.0kHz/1.5kHz (wide/narrow band). In PC mode, adjust the SQL of the 5 frequency points, and save it when the data is stable.

b. Set the RF signal of the comprehensive tester to be -123dBm, and the deviation 3.0kHz/1.5kHz (wide/narrow band). In PC mode, adjust the SQL of the 5 frequency points, and save it when the data is stable.

Chapter7 Major Specification

7.1 General Specification

Model	FP460	
Frequency	(136-174) MHz	(400-470)MHz
Number of Control Channel	16 Zones x 16 Channels	
Channel spacing	25kHz/12.5kHz	
Operating voltage	7.4V, cathode grounded	
Operating temperature	-25°C ~ +55°C	
Antenna impedance	50 Ω	
Microphone impedance	2.2 Ω	
Battery (Standard)	Li-ion Battery: DC 7.4V, 1500mAh, Operating time: 15h (5: 5: 90 cycle)	
Size (H*W*D)	116 mm x54 mm x30 mm	
Weight (g)	240 (with battery and antenna)	

7.2 RX Part

Usable sensitivity (12dB SINAD)	-121dBm
Squelch On sensitivity	≤0.18uV
Adjacent Channel Selectivity	≥70dB/≥60dB
Intermodulation Rejection	≥65dB
Spurious response rejection	≥70dB
Audio output power	1W, Balance @ Distortion ≤5, 16Ω
Rx current consumption	≤400mA

7.3 TX Part

Tx power	4.0W/1.0W @7.4V DC
Frequency stability	≤±2.5ppm
Max. modulation deviation	±3kHz/±1.5kHz
Modulation distortion (300~3000Hz)	≤3%
Adjacent channel Tx power	≤-60dbm/≤-50dbm
Spurious Tx	≤-36dB
Tx current consumption	≤1.4A @ 7.4V DC

Chapter 8 Service and Test Equipment

During the servicing and test process, the following equipments and apparatus will be used:

No.	Equipments	Specifications
1	Standard signal generator	Frequency range: 400-470MHz Modulation: FM and external modulation Output: -127dBm/0.1 uV to > -47dBm/1mV
2	Power meter	Output impedance: 50 Ω Operative frequency: 400-470MHz Measuring range: around 10W
3	Deviation meter	Frequency range: 400-470MHz
4	Digital voltmeter	Measuring range: DC 10mv – 10v Input impedance: load high input impedance to Min. circuit
5	Oscilloscope	Current to 30MHz

6	High sensitivity frequency counter	Measuring range: 50Hz – 10KHz Frequency stability: 0.2 ppm or lower
7	Ammeter	5A
8	Audio frequency voltmeter	Frequency range: 50Hz – 10KHz Voltage range: 1mv – 10v
9	Audio frequency generator	Frequency range: 50Hz – 5KHz or higher Output: 0- 1v
10	Distortion tester	Capacity: 3% or lower @ 1KHz Input power level: 50mV to 10vms
11	Spectrum analyzer	Measuring range: DC – 1GHz or higher
12	Path generator	Center frequency: 50KHz – 600MHz Output voltage: 100mv or higher
13	16 Ω dummy load	Around 16Ω, 3W
14	Adjustable power supply	5v – 10v, around 5A

Chapter 9 Troubleshooting

No.	Problems	Causes and solutions
1	Power ON failure	A. The battery pack may be out of power. Please charge it or change a new one B. Power switch in failure. Change a new one. C. MCU in failure. Change the IC. D. Zener diode Q45 is broken. Change a new IC.
2	PPL unlocked (beeping)	A. The PLL crystal oscillator X500 is broken. Please change it. B. The RDA1846 is broken. Please change it.
3	Cannot talk to or hear other radios	A. The frequency of the radio's current channel is not the same with that of the other radio. Please reselect a channel. B. The CTCSS/DCS is not the same. Please reset it. C. The radio is out of the effective communication

		range.
4	No signal	<p>A. The antenna is in poor contact. Please fasten it.</p> <p>B. The HF amplifying tube Q509 is broken. Please change it.</p> <p>C. The squelch level is too high, so the squelch cannot be opened. Please adjust the squelch level.</p>
5	The indicator lights red while transmitting, but no voice is heard by the recipient.	<p>A. The power amplifying tube is broken, so there is no power output. Please change it.</p> <p>B. The MIC is broken. Please change it.</p> <p>C. The operational amplifier U600 is broken. Please change it.</p>
6	The indicator lights green while receiving, but no sound is heard.	<p>A. The speaker is broken. Please change it.</p> <p>B. The audio power amplifier U600 is broken. Please change it.</p> <p>C. The switch diode Q601 is broken. Please change it.</p>
7	The programming is abnormal	<p>A. The programming cable is not correctly connected to PC. Please check the cable connection.</p> <p>B. The Computer's RS-232 serial port output is abnormal. Please check the computer.</p> <p>C. The earphone jack of the radio is in poor contact. Please check the earphone jack. If it is abnormal, please change it.</p>

Appendix1 Abbreviation

AMP	amplify, amplifier
ANT	antenna
APC	automatic power control
BPF	band pass filter
CTCSS	continuous tone control squelch system
DCS	Digital code squelch
DEMODO	demodulation
HPF	high pass filter

IDC	instantaneous deviation control
IF	intermediate frequency
LED	Light-Emitting Diode
LNA	low noise amplifier
LPF	low pass filter
MCU	micro control unit
MIC	microphone
MOD	modulation
MONI	monitor
PLL	phase lock loop
PTT	push-to-talk
SPK	speaker
TCXO	temperature control X' oscillator
UL	un-lock
VCO	voltage control oscillator
RX	Receiver
TX	Transmitter

Appendix 2 Electronic Parts List

Part No.	Name	Specification	Q'ty	Pulg-in Position
6SS2-4038-HMB	FP460 mainboard patches parts	FP460 mainboard patches parts, no Pb	1	
6SS1-4038-HMB	FP460-02 mainboard patches parts (Version D)	400-470MHZ,FP460-02 mainboard patches parts, no Pb	1	
0SS1-4038-HMD	FP460 mainboard patches parts	FP460 mainboard patches parts,1846S, no Pb	1	
3CF1-BL112-30RU	FFC/FPC connector	0.5mm spacing,30 Pin, horizontal type	1	J201
1DP1-BV08C	R protected diode	BV08C	2	D600,D601
1DR1-NSR1020MW2T1G	Surface mounting schttky diode	NSR1020MW2T1G, No Pb	2	D101,D102
1DS1-DA2S10100L	R Surface mounting switch diode	DA2S10100L	1	D505
1DS1-HSC277	R Surface mounting switch diode (production halts)	HSC277,1608	1	D502
1DS1-HVC131	R Surface mounting switch diode (production halts)	HVC131(P1),1608	2	D500,D501
1DZ1-HZU5ALL	R Surface mounting constant voltage diode	HZU5ALL,2012,5V	1	D504

	(production halts)			
1IL1-NJM2904V	R Surface mounting linearity IC	Double arithmetic amplification NJM2904V,TSSOP-8	2	IC301,IC500
1IM1-AT24C512C	Surface mounting memorizer IC 1IM1-AT24C512BN (replaceable)	AT24C512C, manufacture: ATMEL, no Pb	1	IC200
1IM1-DS28E10P	Surface mounting memorizer IC	Encryption chip, DS28E10P+, no Pb	1	U201
1IM1-M36LOT7050T3ZA Q	Surface mounting memorizer IC	M36LOT7050T3ZAQF, no Pb	1	U401
1IP1-LT1801A	Baseband process module		1	U400
1IS1-MP2359	Surface mounting power supply IC	MP2359,6PIN,1.2A 24V,1.4MHz,TSOT-23-6	2	IC102,IC103
1IS1-RDA1846S	Surface mounting exclusively IC	RDA1846S,PLL module IC , 5*5mm, 32PIN,QFN32, no Pb	1	U500
1IS1-TDA2822	E R Surface mounting exclusively IC	TDA2822	1	U600
1IS1-XC6204B502MR	R Surface mounting constant voltage IC	Constant voltage integration 5V,SOT-23-5	1	IC100
1TF1-2SK1824	R FET	2SK1824(B1)	1	Q506
1TF1-3SK318	R dual-gate fet	3SK318(YB-)	1	Q507
1TF1-RD01MUS2	E R FET		1	Q501
1TF1-RD07MUS2B	E R FET	Mitsubishi, RD07MUS2B, no Pb	1	Q500
1TF1-ST2302	R FET	ST2302,SOT-23	2	Q602,Q603
1TT1-2SA1586	R Surface mounting triode	2SA1586	1	Q605
1TT1-2SC3356-R24	R Surface mounting triode	2SC3356-R24,SOT23,NPN	1	Q503
1TT1-2SC5108-Y	R Surface mounting triode	2SC5108-Y(MC),NPN	1	Q502
1TT1-DTA144EE	R Surface mounting triode	Digital triode, DTA144EE-SMD	1	Q504
1TT1-DTC144EE	R Surface mounting triode	Digital triode, DTC144EE(26),SOT323	9	Q1,Q101,Q103,Q200,Q201,Q 505,Q601,Q604,Q606
1TT1-FMMT717TA	R Surface mounting triode	FMMT717A,PNP,SOT23	1	Q600
1TT1-KTA1298-Y	R Surface mounting triode	KTA1298-Y,SOT23	2	Q100,Q102
2CC1-10-C0G500-101J	R flake multilayer capacitor	1005,100P±5%,50V,C0G	19	C3,C4,C5,C7,C8,C9,C10,C11 ,C24,C225,C237,C238,C239, C240,C241,C242,C243,C521,

					C543
2CC1-10-C0G500-151J	R flake capacitor	multilayer	1005,150P±5%,50V,C0G	2	C301,C561
2CC1-10-C0G500-180J	R flake capacitor	multilayer	1005,18P±5%,50V,C0G	1	C520
2CC1-10-C0G500-220J	R flake capacitor	multilayer	1005,22P±5%,50V,C0G	3	C313,C314,C518
2CC1-10-C0G500-470J	R flake capacitor	multilayer	1005,47P±5%,50V,C0G	2	C558,C560
2CC1-10-C0G500-4R0C	R flake capacitor	multilayer	1005,4P±0.25P,50V,C0G	7	C315,C316,C317,C318,C319, C320,C321
2CC1-10-C0G500-5R0C	R flake capacitor	multilayer	1005,5P±0.25P,50V,C0G	1	C310
2CC1-10-X7R100-105K	R flake capacitor	multilayer	1005,1μF±10%,10V,X7R	4	C219,C220,R606,R607
2CC1-10-X7R160-104K	R flake capacitor	multilayer	1005,100nF±10%,16V,X7R	29	C16,C100,C101,C111,C114,C 117,C127,C223,C224,C228,C 229,C300,C302,C303,C304,C 305,C306,C307,C309,C311,C 312,C322,C323,C324,C325,C 400,C601,C608,C616
2CC1-10-X7R160-333K	R flake capacitor	multilayer	1005,33nF±10%,16V,X7R	1	C583
2CC1-10-X7R250-223K	R flake capacitor	multilayer	1005,22nF±10%,25V,X7R	1	C584
2CC1-10-X7R500-102K	R flake capacitor	multilayer	1005,1000P±10%,50V,X7R	11	C120,C124,C226,C512,C536, C545,C547,C562,C563,C573, C581
2CC1-10-X7R500-103K	R flake capacitor	multilayer	1005,10nF±10%,50V,X7R	11	C110,C112,C115,C126,C308, C529,C539,C540,C548,C600, C612
2CC1-10-X7R500-471K	R flake capacitor	multilayer	1005,470P±10%,50V,X7R	76	C1,C29,C34,C40,C42,C44,C 46,C48,C50,C52,C102,C104, C113,C118,C122,C128,C130, C201,C202,C203,C204,C206, C207,C208,C209,C210,C211, C213,C214,C215,C217,C218, C221,C222,C230,C231,C232, C233,C234,C326,C332,C519, C522,C523,C526,C527,C528, C530,C531,C532,C533,C535, C537,C
2CC1-16-C0G500-120J	R flake capacitor	multilayer	1608,12P±5%,50V,C0G	1	C507

2CC1-16-C0G500-1R0C	R flake multilayer capacitor	1608,1P±0.25P,50V,C0G	1	C534
2CC1-16-C0G500-1R5C	R flake multilayer capacitor	1608,1.5P±0.25P,50V,C0G	1	C504
2CC1-16-C0G500-220J	R flake multilayer capacitor	1608,22P±5%,50V,C0G	1	C502
2CC1-16-C0G500-270J	R flake multilayer capacitor	1608,27P±5%,50V,C0G	1	C510
2CC1-16-C0G500-2R0C	R flake multilayer capacitor	1608,2P±0.25P,50V,C0G	1	C503
2CC1-16-C0G500-3R0C	R flake multilayer capacitor	1608,3P±0.25P,50V,C0G	2	C514,C516
2CC1-16-C0G500-3R5C	R flake multilayer capacitor	1608,3.5P/3.6±0.25P,50V,C0G	1	C505
2CC1-16-C0G500-4R0C	R flake multilayer capacitor	1608,4P±0.25P,50V,C0G	1	C501
2CC1-16-C0G500-5R0C	R flake multilayer capacitor	1608,5P±0.25P,50V,C0G	2	C513,C515
2CC1-16-C0G500-6R0D	R flake multilayer capacitor	1608,6P±0.5P,50V,C0G	1	C509
2CC1-16-C0G500-8R0C	R flake multilayer capacitor	1608,8P±0.25P,50V,C0G	1	C508
2CC1-16-X7R500-471K	R flake multilayer capacitor	1608,470P±10%,50V,X7R	1	C511
2CC1-20-X7R6R3-475K	R flake multilayer capacitor	2012,4.7uF±10%,6.3V,X7R(GR M219R6J475KE19D)	2	C27,C542
2CC1-20-Y5V160-106Z	flake multilayer capacitor	2012,10uF+80%/-20%,16V,Y5V	18	C2,C103,C108,C116,C121,C123,C131,C200,C205,C212,C216,C227,C582,C602,C606,C615,C119,C129
2CT1-TS35-100-470M	R Surface mounting Tantalum capacitor	3528,47uF±20%,10V,TS Series(Grade B)	1	C605
2LH1-R401R5-R03-05	R Surface mounting Air Coil	Wire diameter: φ0.40, Inner diameter: φ1.5, 3 circles, Pin height: 0.5mm, clockwise circling	4	L500,L501,L503,L505
2LH1-R401R5-R04-05	R Surface mounting Air Coil	Wire diameter: φ0.40, Inner diameter: φ1.5, 4 circles, Pin height: 0.5mm, clockwise circling	1	L502
2LH1-R401R5-R08-05	R Surface mounting Air Coil	Wire diameter: φ0.40, Inner diameter: φ1.5, 8 circles, clockwise circling, high Pin	1	L507
2LH1-R501R5-L05-05	R Surface mounting Air Coil	Wire diameter: φ0.50, Inner diameter: φ1.5, 5 circles, anticlockwise, high Pin	1	L506

2LL1-16-12NJ	R multi-layer inductance	1608,12nH±5%(MLG1608B12N J/LL1608-FH12N)	1	L511
2LL1-16-18NJ	R multi-layer inductance	1608,18nH±5%(MLG1608B18N J)	1	L509
2LL1-16-3N3S	multi-layer inductance	1608,3.3nH±0.3nH(MLG1608B3 N3S)	1	L504
2LW1-16UC-270J	R Surface mounting wire wound inductance	1608, 27nH±5%, Ceramic core (C1608CB-27NJ)	2	L3,L6
2LW1-16UC-680J	R Surface mounting wire wound inductance	1608,68nH±5%, Ceramic core (C1608CB-68NJ)	1	L516
2LW1-20UC-221J	R Surface mounting wire wound inductance	2012,220nH±5%, Ceramic core (LQN21AR22J/LQW2BHNR22J 03L)	1	L508
2LW1-25UC-103J	R Surface mounting wire wound inductance	2520,10μH±5%, Ceramic core (FLM2520-100J)	1	L520
2LW1-35UF-473K	Surface mounting wire wound inductance	3.5*3.0*2.1,47UH±10 %,CD32-470K,no Pb	2	L107,L110
2RE1-10-1502	Surface mounting exact Resistor	1005,15KΩ±1%	1	R23
2RE1-10-1602	Surface mounting exact Resistor	1005,16.2K±1%	1	R106
2RE1-10-4909	Surface mounting exact Resistor	1005,49.9K±1%	1	R104
2RE1-10-6409	Surface mounting exact Resistor	1005,64.9K±1%	1	R113
2RE1-10-8006	Surface mounting exact Resistor	1005,80.6K±1%	1	R112
2RE1-16-1503	R Surface mounting exact Resistor	1608,150K±1%	7	R517,R518,R519,R524,R525, R527,R528
2RS1-10-0000	R Chip Resistor	1005,0Ω	26	R3,R4,R5,R6,R17,R19,R26,R 31,R32,C577,R251,R252,R10 9,R306,R312,R339,R404,R50 4,R516,R555,R624,C19,C25, C569,C570,C607
2RS1-10-100J	R Chip Resistor	1005,10Ω±5%	4	R2,R244,R300,R559
2RS1-10-101J	R Chip Resistor	1005,100Ω±5%	6	R317,R318,R319,R320,R321, R322
2RS1-10-102J	R Chip Resistor	1005,1K±5%	35	R8,R9,R108,R209,R210,R21 1,R212,R213,R214,R215,R21 6,R217,R219,R228,R236,R23 7,R238,R239,R310,R502,R50 6,R533,R534,R535,R536,R53

				7,R538,R539,R544,R545,R547,R551,R560,R622,R623
2RS1-10-103J	R Chip Resistor	1005,10K±5%	14	R100,R103,R110,R114,R226,R235,R245,R307,R314,R400,R601,R613,R616,R617
2RS1-10-104J	R Chip Resistor	1005,100K±5%	18	R107,R220,R221,R224,R225,R229,R231,R232,R233,R234,R309,R311,R324,R325,R326,R402,R403,R549
2RS1-10-105J	R Chip Resistor	1005,1M±5%	1	R526
2RS1-10-152J	R Chip Resistor	1005,1.5K±5%	1	R507
2RS1-10-153J	R Chip Resistor	1005,15K±5%	3	R302,R304,R542
2RS1-10-154J	R Chip Resistor	1005,150K±5%	1	R550
2RS1-10-182J	R Chip Resistor	1005,1.8K±5%	1	R20
2RS1-10-183J	R Chip Resistor	1005,18K±5%	2	R301,R303
2RS1-10-184J	R Chip Resistor	1005,180K±5%	1	R553
2RS1-10-220J	R Chip Resistor	1005,22Ω±5%	6	R1,R7,R33,R511,R543,R604
2RS1-10-221J	R Chip Resistor	1005,220Ω±5%	3	R249,R250,R548
2RS1-10-222J	R Chip Resistor	1005,2.2K±5%	7	R101,R102,R248,R305,R600
2RS1-10-223J	R Chip Resistor	1005,22K±5%	2	R27,R614
2RS1-10-271J	R Chip Resistor	1005,270Ω±5%	1	R505
2RS1-10-273J	R Chip Resistor	1005,27K±5%	1	R531
2RS1-10-274J	R Chip Resistor	1005,270K±5%	1	R105
2RS1-10-204J	R Chip Resistor	1005,200K±5%	1	R340
2RS1-10-330J	R Chip Resistor	1005,33Ω±5%	1	R510
2RS1-10-333J	R Chip Resistor	1005,33K±5%	2	R609,C611
2RS1-10-334J	R Chip Resistor	1005,330K±5%	1	R315
2RS1-10-392J	R Chip Resistor	1005,3.9K±5%	1	R514
2RS1-10-393J	R Chip Resistor	1005,39K±5%	1	R512
2RS1-10-470J	R Chip Resistor	1005,47Ω±5%	1	R500
2RS1-10-471J	R Chip Resistor	1005,470Ω±5%	2	R15,R612
2RS1-10-472J	R Chip Resistor	1005,4.7K±5%	2	R561,R562
2RS1-10-473J	R Chip Resistor	1005,47K±5%	19	R202,R203,R204,R205,R206,R207,R208,R227,R240,R241,R242,R243,R501,R508,R513,R540,R541,R557,R558
2RS1-10-474J	R Chip Resistor	1005,470K±5%	1	R605
2RS1-10-561J	R Chip Resistor	1005,560Ω±5%	1	C578
2RS1-10-562J	R Chip Resistor	1005,5.6K±5%	1	R503
2RS1-10-563J	R Chip Resistor	1005,56K±5%	1	R529
2RS1-10-820J	R Chip Resistor	1005,82Ω±5%	1	R316
2RS1-10-822J	R Chip Resistor	1005,8.2K±5%	2	R308,R22

2RS1-10-823J	R Chip Resistor	1005,82K±5%	1	R509
2RS1-16-000O	R Chip Resistor	1608,0Ω	8	L7,L100,L103,L105,L108,L109,L111,L510
2RS1-16-153J	R Chip Resistor	1608,15K±5%	1	R515
2RS1-20-000O	R Chip Resistor	2012,0Ω	2	C337,L104
2RS1-32-000O	R Chip Resistor	3216,0Ω±5%	1	F100
2RS1-32-R47J	R Chip Resistor	3216,0.47Ω±5%	3	R520,R521,R522
4PE1-16-F2	R Surface mounting LED	1608, red light,19-21SUR/S530-A2/TR8	1	D203
4PE1-16-F5	R Surface mounting LED	1608, green light, H19-213SYGC	1	D205
5FE1-BLM11A601S	R Surface mounting EMI Filter	1608,BLM11A601S/BLM18AG601S(0138-05)	8	L1,L2,L300,L513,L515,L517,L521,L600
5FE1-BLM21P300S	R Surface mounting EMI Filter	2012,BLM21P300S/BLM21PG300S(0149-05)	2	L512,L514
5OD1-18R4-AEL-0302A	Surface mounting Temperature compensated crystal oscillator	KDS,DSA321SDA,18.432MHz,±2.5PPm,-40~+85℃,3.2*2.5*0.9mm	1	X300
5OT1-12R8-CEC3-0503	R Surface mounting Temperature compensated crystal oscillator	NT5032SA/NT5032SC,12.8MHz±2.5PPm,5.0*3.2*1.6mm	1	X500
5XT1-MC146-32R76K	E Surface mounting Ceramic Rasonator	32.768KHZ,MC-146,12.5PF,20P PM, no Pb	1	X301
7MDC-4057-02A-G	FP460(DP460) battery springy splinter	Material: brass; Nickel plating, gold coat; no Pb	4	DC
6PD7-4038-HMD	FP460 mainboard PCB	UHF mainboard, four layer board, FP460_MAIN_130513.PCB,FR4 ,1.0mm,97X21MM, no Pb	1	
2CC1-10-X7R500-183K	Chip multi-layer capacitor	1005,18nF±10%,50V,X7R	1	C30
2RS1-10-683J	R Chip resistor	1005,68K±5%	1	R21
0SS2-4038-HMB	FP460-02 mainboard plug-in parts (Version D PCB)		1	
7MIC-4038-01A-WC	FP460_3.5 Earphone spacer	Material:T=0.6 PC; transparency; one side glue; no Pb	1	J600
3CE3-CZ25-C	R 2.5mm Earphone socket (PT6500, PT4208,RD5700,CD3700, DP460, KME-216,P	MOTOROLA connector PJ-D2008B, DC30V0.5A, 090824 modification	1	J601

3CE3-CZ35-C	3.5mm Earphone socket FP460	MOTOROLA connector, include switch, the distance to center:1.85mm, high: 3.9mm, no Pb	1	J600
2RW3-RP08110SNJX-V01	Volume switch (FP460/765/780/785/660/770)	RP08110SNJX-V01-0001, with fixed location, no Pb	1	POW&VOL
3SE3-RE08220HX-V02	Channel switch (FP460 /765 /785 /660 /780)	4.75mm axis, M6 screw thread, RE08220HX-V02-0000,无铅	1	S200
6SS1-4038-HKA	FP460 keyboard surface mounting parts	DP460 keyboard surface mounting parts, no Pb	1	
0SS1-4038-HKA	FP460 keyboard surface mounting parts	DP460 keyboard surface mounting parts, no Pb	1	
3CF1-BL112-30RU	Surface mounting FFC/FPC connector	Spacing:0.5mm,30 core, horizontal type	1	J1
3CF1-BL112-20RL	R Surface mounting FFC/FPC connector	Spacing: 0.5mm,20 core, horizontal type	1	J2
1TT1-DTC144EE	R surface mounting triode	Digital triode, DTC144EE(26),SOT323	1	Q201
4PE1-16-F9-A	Surface mounting LED	LED, 0603, white, Height:0.4mm	6	D1,D2,D3,D4,D5,D205
2RS1-10-100J	R Chip resistor	1005,10Ω±5%	3	R1,R2,R244
2RS1-10-221J	R Chip resistor	1005,220Ω±5%	1	R250
6PD7-4038-HKD	FP460 keyborad	Two layer board, DP460U-KEY-121205, thickness:0.6MM, Material:FR-4,46.6X40MM, no Pb	1	

Appendix 3 Spare Parts List (Structure Part)

0SS3-4038-HMB	FP460 mainframe assemble (PCB D Version)	FP460 mainframe assemble ,Lead free	1	
7MHP-4038-02A-W0	FP460 Top Cover	Material :PC+ABS; black;texturing;Guokai; Lead free	1	
7MHP-4038-03A-W0	FP460 Volume Knob	Material:ABS;black;texturing,white oil painted;Guokai;Lead free	1	
7MHP-4038-04A-W0	FP460 Channel Knob	Material:ABS;black;texturing,white oil painted;Guokai;Lead free	1	
7MHP-4038-07A-W0	FP460 Earphone socket waterproof cushion	Material:TPU;Black; texturing;Guokai; Lead free	1	
7MHL-4038-01A-W	FP460 Aluminum Chasis	Material :ADC12; true color ;Polished and storving varnish;Fuda; Lead free	1	
7MHR-4038-02A-W0	FP460 Main Waterproof	Material :silica;black;highlight;Mingkun;L	1	

		lead free		
7MHR-4038-04A-W0	FP460 top waterproof	Material :silica;black;polishing;Mingkun;Lead free	1	
7MHR-4038-05A-W0	FP460 spring contact socket	Material :silica;black;polishing;Mingkun;Lead free	1	
7MHR-4038-06B-W0	FP460 Keypad	Material :ABS/stainless steel/silica gel;laser carving;character translucidus;Jiaxinde;Lead free,silk printed	1	
7MHS-4038-01A-W	FP460 keypad metal dome	Metal :φ4mm,SUS301 round metal dome;waterproof;Lixinghui;Lead free	1	
7MHS-4038-02A-W	FP460 PTT Metal Dome	Material :φ5mm,SUS301 round metal dome;Lixinghui;Lead free	1	
7MBR-4038-02A-W0	FP460 speaker silica cushion	Material :silica gel;black;Mingkun;Lead free	1	
7MHS-4038-04A-W	FP460LCD holder with shielding cover	stainless steel , 0.3mm thickness , Junyu,Lead free	1	
7NRC-060090035-W1	FP460(DP460)Knob Nut	Material:Brass, inner diameter M6mm,external diameter φ9mm, thickness3.5mm,Junyu,Lead free	2	
4PC7-4038H-A	LCD Display	semipermeable,Vertical Display, but placed horizontally,backlight 42.7mm Height Zhongyiwei,Lead free	1	
7SMF-020040M-SZYB-N	R M2*4 Cross round flat head machine screws (558/PT4200/PT558S/5200/PT	Material :hardened iron,φ2mm*4mmCross round flat head nickel plating machine teeth, metric coarse thread,NYLOK	8	To lock the main PCB board and antenna connector
7SMF-020080M-MHHT-N1	R M2*8 wintersweet type thick head machine screws (558/E66/PT558/4200/PT4200/5200/PT65	Material: hardened iron ,φ2mm*8mm wintersweet type thick head nickel plating machine, metric coarse thread. NYLOK	2	To fix the mainframe(aluminum chassis)
7MHR-7042-06B-W0	R thermally conductive pad	Silica gel, black ,3*6*9mm,Shenzhen Kuayue Eletronic, softer than A version, Lead free	1	
3CR7-SMA-50JF-4	Antenna connector	SMA-J	1	
7NRC-090110025-W1	Antenna Nut	Material copper ,inner diameter M9mm,external diameter φ11mm, thickness 2.5mm, no surface treatment	1	
7MHS-1140-01A-W	R 3118/3208 Knob circlip	Material: spring steels	2	
7SMF-025080M-SZYB-Z1	R M2.5*8 Cross round flat head machine screws (4208/PT4208/ AP570/ DP570/ S660/ PT56	Material :hardened iron,φ2.5mm*8mmCross round flat head black zinc plating machine teeth, metric coarse thread	2	To fix the belt clip

3WF7-05030-500C4	Soft Connector	Spacing 0.5mm,30P, length 50mm, length of the ednd 3mm, reinforce 4mm, two-headed single direction	1	
6PD7-4038-HPB	FP460 PTT Board	Double-side PCB Board,DP460-PTT-121205.PCB,FR4,38 X9.3MM thickness:0.4MM,Lead free	1	
7MHZ-1731-01A-J5	R 3300 Speaker Insulation Paper	Material: Dark green Highland barley paper,Length 18mm*width 8mm thickness 0.2mm,one side with glue	2	
7STF-020055B-SZHT-B	M2*5.5 cross thick head self tapping screws	Material: hardened iron,Φ2mm*5.5mmCross head flat end with thick black oxide	2	To fix the speaker holder
6SS3-MK4038-HMA	FP460 Front Cover assembly (40MM Big Speaker)		1	
7MHP-4038-11A-W0	FP460 Front Cover	Material :PC+ABS;black;texturing/silk printed;40mm speaker,Guokai;Lead free	1	
7MHP-4038-05C-W0	FP460PTT Cover	Material:ABS,double color texturing;0608, Guokai; Lead free	1	
7MHP-4038-06A-W0	FP460 Earphone Cover	Material:TPU;black; texturing;Guokai;Lead free	1	
7MHR-4038-01A-W0	FP460 silica side key	Material :silica gel; black ;laser carving PT Orange21C; Mingkun; Lead free	1	
7MHR-4038-04A-WC	FP460 light pipe	Material :silica gel; transparent;hightlight; adapt with 40mm speaker. Mingkun;Lead free	1	
7MHM-4038-02A-W9	FP460 LCD sponge	Material:T=0.5mm sponge; black;one side with glue PET ;Xinlongda; Lead free	1	
7MHJ-4038-01B-W	FP460 Lens back glue	Material :3M9448;Xinlongda;Lead free	1	
7MHJ-4038-02B-W	FP460 keypad back gle	Material 3M9448;Xinlongda; Lead free	1	
7MJS-4038-01A-W0	FP460 spindle	Material :SUS304; true color ;Bayang;Lead free	1	
7GCB-S4038-01A	FP460 speaker net	Nylon net;black;Xinlongda;Lead free	1	
7MHP-4038-12A-W0	FP460 speaker holder	ABS,black,Quanzhou Fengyu, Lead free	1	
4SS7-4005-016-100C	Speaker 7200,6500, S780, S785, FP460, S765,567	11.3.25 craft changed,Φ40, impedance 16Ω,Power1W, Supplier:Fushengda, Lead free	1	
6SS3-BJ4038-A	KBJ-17 Belt Clip	FP460 Belt Clip, Lead free	1	
0SS3-4038-A	KBJ-17 Belt Clip Jacking	PC+ABS,black , for FP460	1	
7MJP-4038-01B-W0	KBJ-17 Belt Clip	Material, black, PC+ABS; black ,thickened and enhanced, Mingli, Lead free	1	
7MJS-7013-01B-N	R KBJ-09 Belt Clip Holder	Stainless steel (SUS304),1.00THK,Nickel Flash,Quanzhou Pingan Hardware, Lead free	1	

7MJS-7013-02A-W	R KBJ-09 Belt Clip torsional spring	φ1.00 Stainless Steel Wire, Lead free	1
7MJS-7154-02A-W0	GD-9 Belt Clip Spindle	SUS304, passed 48H salt spray test, Lead free	1

Appendix 4 Accessories reference List

Accessories	Quantity
Antenna	1
Belt Clip	1
Earphone Cover	1
Screw	1
Battery	1
Charger	1
Adaptor	1
Instruction Book	1
Warranty Card	1
Sling	1

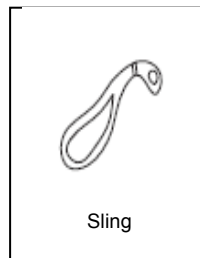
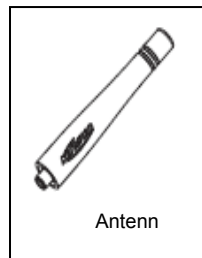
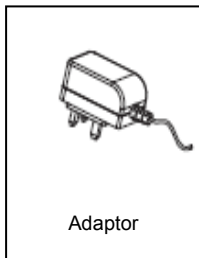
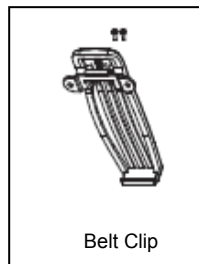
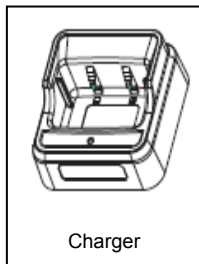

Figure1 FP460 Schematic Pane Diagram

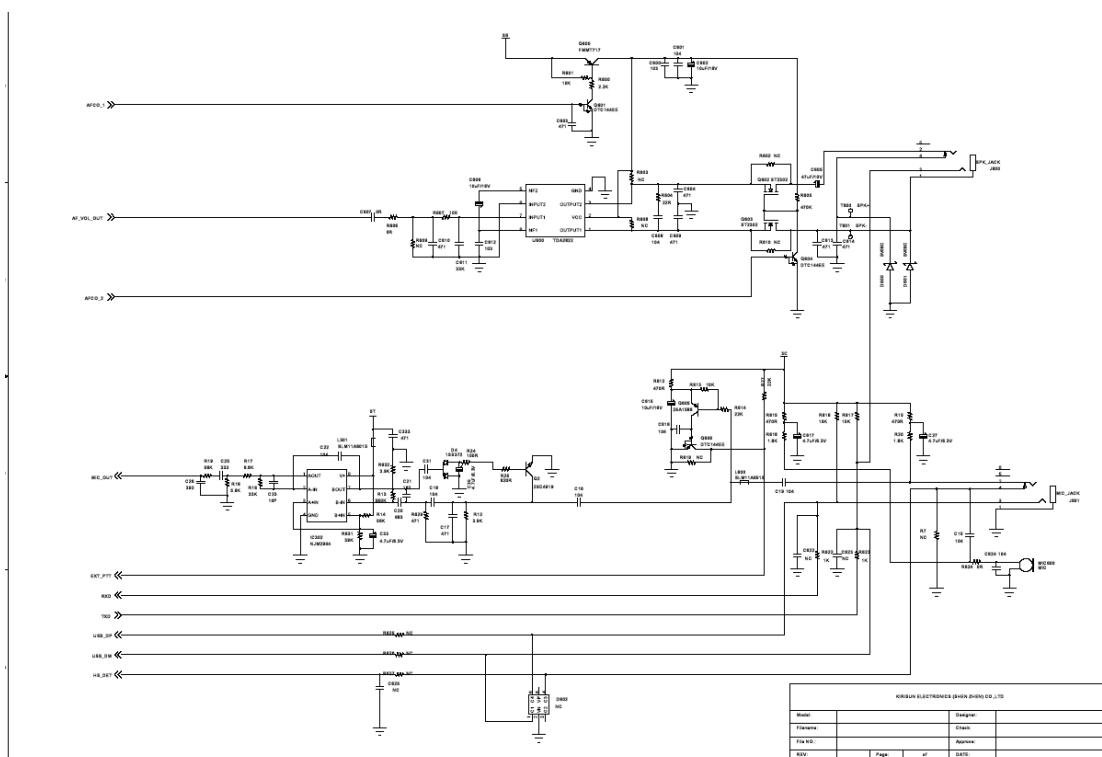
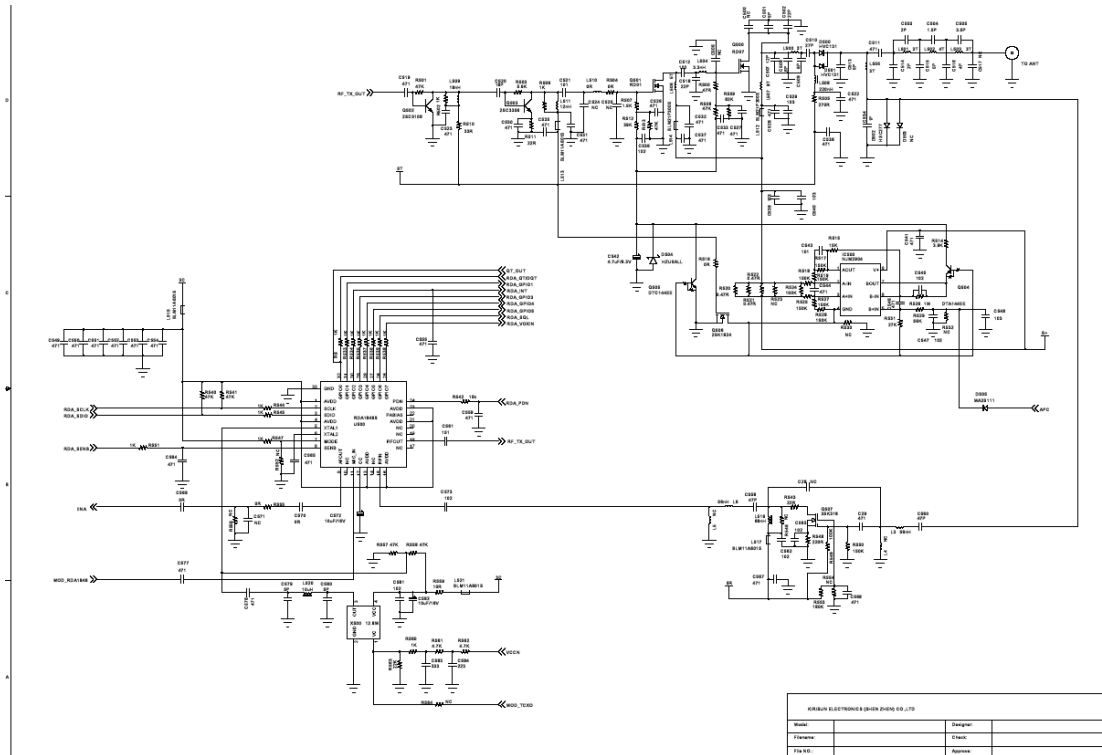

Figure2 FP460 Top Board Position Mark Diagram

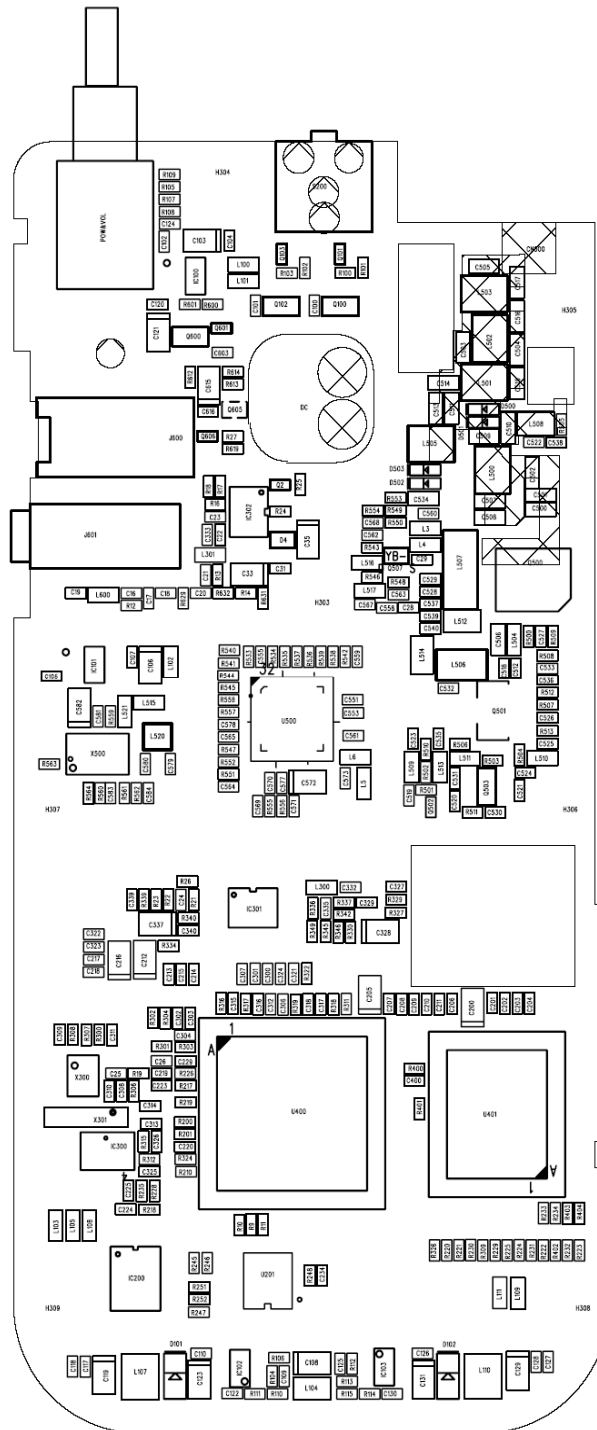

Figure3 FP460 Bottom Board Position Mark Diagram

