



# Instruction Manual

## PT280

### Commercial Portable Two-way Radio

We are very grateful for your purchasing  brand two-way radios produced by Shenzhen Kirisun Electronics Co., Ltd.

We believe  two-way radio, which always incorporates the latest technology, can bring great convenience to your life and work.

We also believe that the quality and function of  two-way radio can meet your demands for reliable communication.

#### Notice to the User:

- Government laws prohibit radio communication without permission in government districts.
- Illegal operation is subject to punishment by fine and/or imprisonment.
- Servicing is only allowed to be operated by the well-trained professional technicians.

Safety: The user should notice of the common danger about using the radio.

#### Warning:

Turn off your radio before entering any area with a potentially explosive atmosphere (where the air contains gas, dust and smog, etc.), such as while taking on fuel, or while parking at a gasoline service station.

#### Attentions:

Please comply with the following attentions to avoid fire, personal injury and damage to the radio.

- \* Long time transmitting or continuous working in high power mode will make the rear side of the radio generate heat.
- \* Never disassemble the radio.
- \* Please do not expose the radio to direct sunlight for a long time; do not place the radio near any heating device, either.
- \* Please do not put the radio in extremely dusty, moist or dabbling places; do not place it on any unstable surface, either.
- \* If the radio emits smoke or strange odors, turn it off and remove the battery from the radio and contact your local authorized Kirisun dealer without delay.

## Contents

■	Unpacking and Checking .....	4
◆	Accessories.....	4
■	Preparation .....	4
◆	Charging the Battery.....	4
◆	Installing/Removing the Battery.....	6
◆	Installing/Removing the Antenna.....	6
◆	Installing/Removing the Belt Clip .....	6
◆	Installing the External Earphone.....	7
◆	Installing the Hand Strap.....	7
■	Radio Overview .....	7
■	Basic Operation.....	9
◆	Switching from Channel Mode to FM Broadcast .....	9
◆	Searching FM Station.....	9
◆	Inputting the Frequency .....	9
◆	Inputting the Channel Number .....	9
◆	Adjusting the Frequency/Channel .....	10
◆	Emergency Alarm.....	10
◆	Temporary Squelch/Squelch ON/OFF .....	10
◆	Receiving a Call .....	10
◆	Sending a Call.....	10
◆	Side Button [PF1].....	10
◆	Side Button [PF2].....	11
◆	Working Mode Switch .....	11
■	Shortcut Operation.....	11
◆	Editing a Channel.....	11
◆	Deleting a Channel .....	11
◆	On/OFF FM Broadcast .....	12
◆	ON/OFF Alert Tone .....	12
◆	CTCSS/DCS Scan.....	12
◆	Setting the Beat Frequency.....	12
◆	Frequency /Channel Scan.....	13
◆	Channel Scan Skip.....	13
◆	Priority Scan.....	14
◆	High/Low Power .....	14
◆	DTMF Encode Check and Settings.....	14
◆	Sending DTMF Signal Manually.....	14
◆	Sending Selected Call, Group Call and All Call with DTMF Encode .....	15
◆	Kill/Waken .....	15
◆	Stun/Waken .....	15
◆	Reverse Channel/Talk around .....	16
◆	Keypad Lock .....	16
■	Operation and Introduction of Channel Functions.....	16
◆	CTCSS/DCS Decode .....	17

◆	CTCSS/DCS Encode.....	17
◆	CTCSS/DCS Decode and Encode Synchronization.....	17
◆	Beat Frequency.....	18
◆	Wide/Narrow Band.....	18
◆	Reverse Frequency or Talk around.....	19
◆	Voice Encryption.....	19
◆	Voice Comanding.....	19
◆	Busy Channel Lockout.....	20
◆	Enable/Disable Optional Signaling.....	20
◆	Signaling Relation.....	21
◆	PTT ID.....	21
◆	Tx Prohibit.....	21
◆	Whisper.....	22
■	<b>Operation and Introduction of Radio Functions.....</b>	<b>22</b>
◆	Voice Annunciation.....	22
◆	Timeout Timer.....	23
◆	VOX.....	23
◆	VOX Hold Time.....	23
◆	VOX Alert Tone.....	24
◆	Step Frequency.....	24
◆	Squelch Level.....	24
◆	Battery Save.....	25
◆	Backlight.....	25
◆	Color of Backlight.....	25
◆	Scan Temporary Stay Time.....	26
◆	Display Mode.....	26
◆	Single Tone Pulse Frequency.....	27
◆	DTMF Transmitting Time.....	27
◆	BEEP Tone Volume.....	27
◆	Priority Channel.....	28
◆	Battery Voltage Check.....	28
◆	Restore Factory Settings.....	28
■	<b>Programming Software Installation.....</b>	<b>29</b>
■	<b>Specifications.....</b>	<b>29</b>
■	<b>Troubleshooting.....</b>	<b>31</b>
■	<b>Appendix 1 DCS Frequency List.....</b>	<b>32</b>
■	<b>Appendix 2 CTCSS Frequency List.....</b>	<b>33</b>

## ■ Unpacking and Checking

Unpack the radio carefully. We recommend that you check the radio and the supplied accessories listed in the following table before discarding the packing material. If any damage or loss has occurred during shipment, please contact the dealer without delay.

### ◆ Accessories

Item	Quantity
Antenna	1
Battery pack	1
Belt clip	1
Charger base	1
Power adapter	1
Hand strap	1
Instruction manual	1

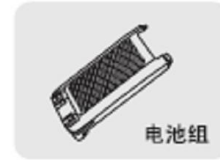

## ■ Preparation

### ◆ Charging the Battery

The radio is not charged before leaving the factory. Before initial use, please charge the new battery. Initially charging the battery pack after purchase or extended storage (greater than two months) will not bring the battery pack to its normal operation capacity, after repeating the charge/recharge cycle two or three times, the operation capacity will increase to normal. If the operating time of the battery does not increase after the charging, please change a new battery, because its life is over.

#### Type of Charger

Please charge the battery with the charger provided by Kirusun: Charging with unauthorized charger may cause explosion and personal injury. If the screen displays  after the battery is installed, it indicates that the battery is out of power, please charge the battery.

#### Attentions

Do not reverse the battery polarity or discard the battery in the fire. Never disassemble the battery or the cover of the charger. Kirusun does not take the responsibility of any problems which are caused by any unauthorized modification.

The ambient temperature of charging should be kept within 5~40°C. Charging beyond this temperature range will affect the performance of the charging and the battery cannot be charged fully.

If you are inserting the radio in the charger to charge, please turn off the radio first, otherwise it will affect the charging.

During the charging, do not plug off or in the power supply and the battery, otherwise it will affect the charging program.

If the battery finishes charging, do not reinsert the battery to recharge it, otherwise it will shorten the battery life and damage the battery.

If the battery or the radio is wet, do not charge the battery immediately. Please wipe off the liquid first so as to avoid danger.

### Warning!

Contacting the conducted metal such as ornament, keys or jewelries with the battery terminal may cause damage, personal injury. Reversing the terminals will cause large quantity of heat. When carrying or using the battery, please put it in the insulated container, and never put it in the metal container.

### Steps of Charging

Insert the adapter to the socket of AC output, and then connect the adapter with the charger. LED indicator lights in orange for one second and then lights off, the charger enters into standby state.

Insert the battery or the radio into the charger base. Make sure the battery and the charger terminal is well connected. Then LED indicator flashes in red, and the charger enters into pre-charge state.





After about 5 minutes, LED indicator stops to flash, and the charging begins.

The battery should be charged for 4 hours. When LED indicator turns to be green, the charging finishes. And take off the battery or the radio.

Note:

If the radio is inserted into the charger in the power-on state, the LED indicator cannot turn to be green when the charging is complete. Only when you power off the radio, the indicator will return to normal. (This is because the radio will consume the battery in the power-on state so that the battery cannot be charged fully.)

### Charging Process

Status	Indicator state
Wait for charging (Self check after inserting in, orange LED indicator lights for one second.)	 No display ↓
Pre-charging (Pre-charging phase)	 Red LED indicator lights for 5 minutes. ↓
Start charging (Constant current charging phase)	 Red LED indicator lights for 5 minutes. ↓
Finish charging (Constant voltage charging phase)	 Green Led indicator lights.

### LED Indicator State

State	LED
Self Test	Orange (one second)

No battery	No display
Pre-charge	Red LED indicator lights for 5 minutes.
Charging	Red LED indicator lights for 5 minutes.
Complete charge	Green Led indicator lights.
Error	Red LED indicator flashes constantly.

Note: Error includes heat emitting from the radio, short circuit of battery or charger base.

### **Charging Notice**

Self test: When the charger base electrifies, orange LED indicator lights for one second. If the radio enters pre-charging state, self test passes; if the orange or red LED indicator flashes constantly, self test fails, and charging cannot be done.

Pre-charge: Insert the battery in; red LED indicator flashes, the battery is in low voltage. Pre-charge the battery; after the battery voltage arrives to a certain amount (red LED indicator stops to flash), charge the battery automatically.

Note: Time for pre-charging cannot exceed 30 minutes. If red LED indicator still flashes after 30 minutes, charging cannot be done. Please check the battery and the charger base.

### **Battery Storage**

Keep the battery in 50% capacity in storage.

Keep the battery in cold and dry environment.

Keep the battery away from the heat source and direct sunlight.

### **Warning**

Do not reverse the battery polarity.

Do not attempt to reassemble the battery cover.

Do not install the battery in the dangerous environment. The sparkle may cause explosion.

Do not discard the battery in the high temperature environment or fire, which may cause explosion.

### **◆ Installing/Removing the Battery**

Match the three protrusions on the battery pack with the slots at the rear of the radio, and push forward.

Press the battery down to lock it until a click is heard.

To remove the battery, press down the battery latch, and push backward to separate it from the radio.

### **◆ Installing/Removing the Antenna**

Installing the antenna:

Hold the base of the antenna, match the antenna with the connector on the top of the radio, and rotate clockwise until fasten it.

Removing the antenna:

Rotate counterclockwise until the antenna separates from the radio.

### **◆ Installing/Removing the Belt Clip**

Installing the belt clip

Match the belt clip with the screw holes at the back of the radio, and fasten it with two screws.

Removing the belt clip

Use screwdriver to take off the screws and remove the belt clip.

### ◆ Installing the External Earphone

Uncover the cover on the jack; insert the earphone into the jack.

If you do not use the earphone, cover the jack.

Note:

Cover the jack to keep the radio in water resistance state.

Using the earphone will affect the water resistance performance.

### ◆ Installing the Hand Strap

Cross one end of the hand strap through the ring on the radio; cross the other end through the strap, and then fasten it.

## ■ Radio Overview

You can see that there are icons on the screen. The following descriptions help you to know the meaning of each icon.

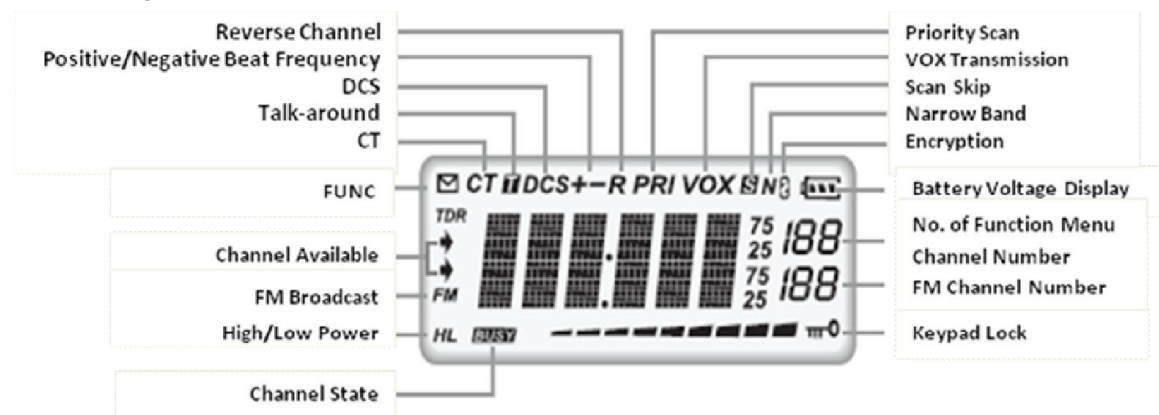

Note:

Full voltage

Low battery, Please change or charge the battery.

The remaining battery voltage

Signal strength, voltage

**Front View**

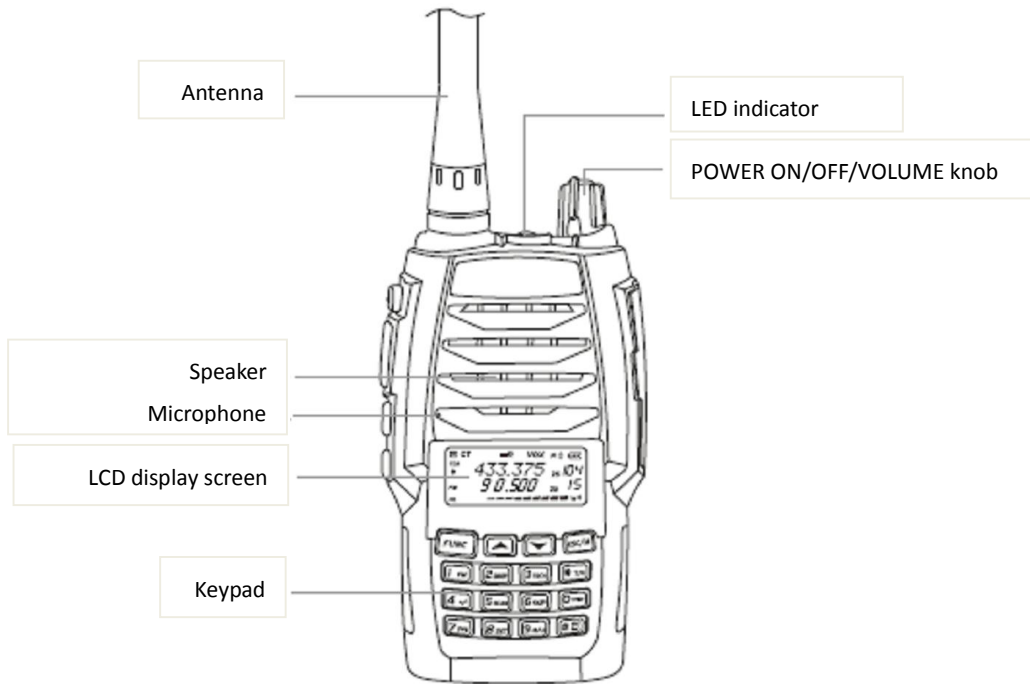

**Side View**

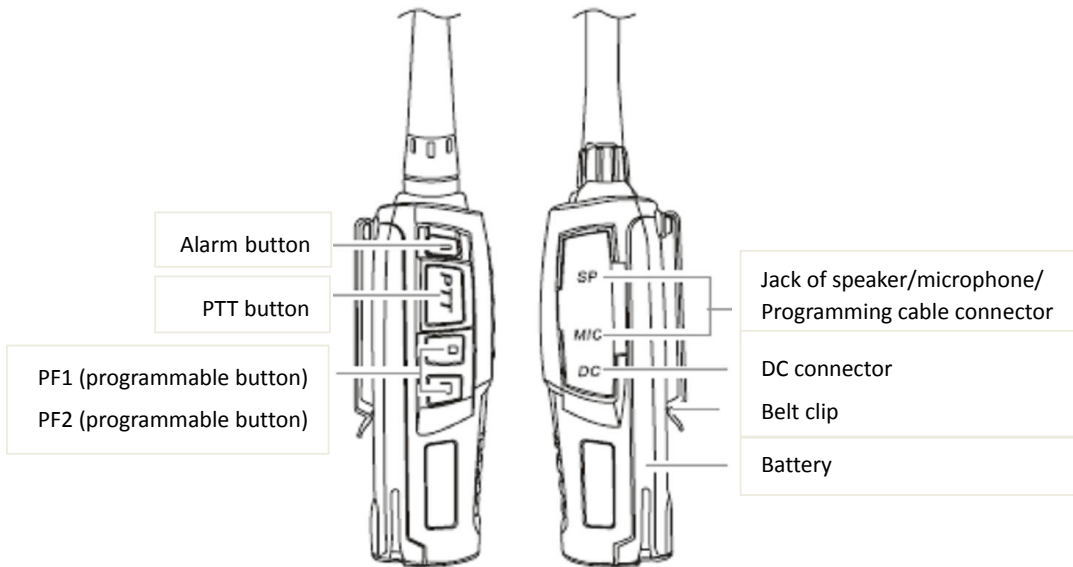

◆ **Powering ON/OFF the radio**



Rotate the [POWER]/ [VOLUME] knob clockwise to turn on the radio.



Rotate the [POWER]/ [VOLUME] knob counterclockwise to turn off the radio.



## ◆ Adjust the Volume





Turn on the radio, and rotate the [POWER]/ [VOLUME] knob to adjust the volume. Rotate clockwise to turn up the volume; rotate counterclockwise to turn down the volume. During the adjustment, press [PF2] button to monitor the current background noise. (PF2 can be programmed for different functions.)

Note: Press the [PF2] programmed as temporary squelch off to monitor the background noise. Rotate the [POWER]/ [VOLUME] knob to adjust the volume. You can also adjust to the suitable volume during the communication.



## ■ Basic Operation

### ◆ Switching from Channel Mode to FM Broadcast

Press  and then  to switch from channel mode to FM broadcast. When switching to FM broadcast, the radio will turn on FM broadcast and Channel Functions automatically. The arrows on the display indicate the current available channel.

Note: You can only edit, delete, lock the keypad and On/Off BEEP Tone in FM broadcast, the rest of the functions are in channel mode.

### ◆ Searching FM Station

FM broadcast is on, you can press  or  to search the stations. When a station is searched, its frequency will display on the screen, and you can listen to this station.

### ◆ Inputting the Frequency

This function is available in channel frequency mode or FM broadcast frequency mode.

If your radio is in frequency +channel mode, press  to switch to temporary channel mode (VFO).

Note: If the radio is in frequency + channel mode, the current channel number will display at the right of the screen.

Input the desired frequency with the keypad.



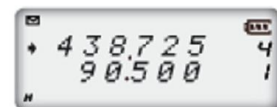

Note: The input frequency should be within the frequency range and conform to step rule. If this frequency is out of the range or does not conform to the step rule, it is invalid. In the FM broadcast mode, the step value is 50K.







### ◆ Inputting the Channel Number

Input 3 digits (e.g. 001~128) of the desired channel number in the frequency + channel mode or channel name mode, the radio switches to this channel. If this channel is not programmed, the radio sends out a sound indicating that an error occurs, and returns to the previous channel. 001 refers to channel 1; 030 refers to channel 30; 125 refers to channel 125.

### ◆ Adjusting the Frequency/Channel

In the VFO mode, press  /  to adjust the current frequency. Press  to increase the frequency; press  to decrease it.

Note: Step value available: 5K, 6.25K, 10K, 12.5K, 15K, 20K, 25K, 30K and 50KHz. Please refer to Step Frequency Settings.

In channel mode, press  or  to select the desired channel. Press  to move to the next channel; press  to back to the previous channel.

### ◆ Emergency Alarm

Set Side Button [PF1] as Alarm Button. Press it to send out an alarm and transmit the alarm to the other radio. Press it again to cancel the alarm.

Note: This function must be set by the programming software.

### ◆ Temporary Squelch/Squelch ON/OFF

Set Side Button [PF2] as Temporary Squelch/Squelch On/Off. Press it to monitor the weak signal.

Temporary Squelch On/Off: press and hold [PF2] Button, squelch circuit is unmuted; release it to mute the circuit.

Squelch On/Off: press [PF2] Button, squelch circuit is unmuted; press it again to mute the circuit.

Note: This function must be set by the programming software.

### ◆ Receiving a Call

When the working channel is called by the other radio, green LED indicator lights up, and you can hear the call.

Note: If you have set the squelch to a higher level, you may not be able to receive this call.

If the current channel has set the decoding signaling, the radio can only receive the call from the radio with the same signaling. (Details please refer to Signaling Relation)

### ◆ Sending a Call

Press Side button [PF2] programmed as Temporary Squelch/Squelch On/Off to monitor the signal, and to confirm that the channel you want to transmit is in idle state. Then press [PTT] button and speak to the microphone.

Please keep your mouth 2.5~5cm to the microphone, and speak in normal tone to transmit the best voice.

Note: Press [PTT] button, red LED indicator lights up and the call is transmitted; release it to receive a call.

### ◆ Side Button [PF1]

Side button [PF1] can be programmed to realize the following functions by short press and long press:

Send a call: in standby state, press [PF1] to send the pre-saved and selected DTMF signaling;  
Alarm on: in standby state, press [PF1] to initiate an alarm; the radio will send out an alarm tone and transmit the alarm to the other radio or the monitor center. Press the button again to end the alarm. When the alarm sounds for one second, it will automatically turn off and the radio returns to standby status;

Alarm off: press this button to cancel the alarm when an alarm sounds;

ON/OFF the spotlight: in standby state, press it to turn on the light; press it again to turn off the spotlight.

To send out the single tone pulse signal (e.g. 1750HZ) in the transmission;

Default setting: short press to turn on the spotlight; long press to initiate the alarm.

### ◆ Side Button [PF2]

Temporary squelch on/off: in the standby state, press the key to turn on the temporary squelch; release it to turn off the temporary squelch;

Squelch on/off: in standby state, press this key to turn on the squelch; release it to turn off the squelch;

Press this key to turn on the radio, and hold it for 3 seconds, the radio enters Radio Function Settings mode;

Default setting: temporary squelch on/off.



### ◆ Working Mode Switch (switch from VFO mode to Frequency + Channel Number mode)



Press  to switch from VFO mode to Frequency + Channel Number mode.

Note: If the current channel is not programmed, the operation is invalid.

## ■ Shortcut Operation

### ◆ Editing a Channel

In the VFO mode, input the desired channel frequency, and then press , the icon  displays on the screen. Then press  for 2S, a sound of “Du Du” is heard, the screen displays the signal strength, and you can edit the channel.

Press  /  to select the desire channel number;

Press and hold  for 2S, a sound of “Du Du” is heard, which indicates that the channel is saved.

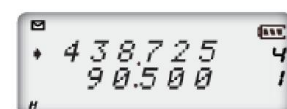

### ◆ Deleting a Channel

In the Channel mode, press , the icon  displays at the





upper left of the screen. Then press  for 2S, a sound of “Du Du” is heard, the radio skips to the next channel and the previous channel is deleted.

#### ◆ On/OFF FM Broadcast

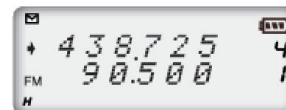







In the standby state, press , the icon  displays on the upper left of the screen. Then press , the icon “FM” displays on the screen, which indicates that FM broadcast is on. Repeat the above operation to turn off the FM broadcast.



#### ◆ ON/OFF Alert Tone



This function is used to alert the input operation, error and malfunction. In the standby state, press , the icon  displays on the upper left of the screen. Then press  to turn off BEEP alert tone. Repeat the above operation to turn on the alert tone. We recommend you to turn on alert tone.

#### ◆ CTCSS/DCS Scan

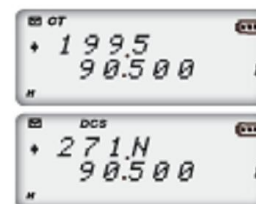

Press , the icon  displays at the upper left of the screen. Then press  to begin CTCSS/DCS scan. You can press / to change the direction of the scan. When the CTCSS/DCS matches with the radio, the scan stops for 15s and then continues. You can press any keys except ,  and  to exit the scan.



Note: This function is invalid in other mode or the current channel does not set CTCSS/DCS. If the current channel has set the signaling as CTCSS, the radio scans the CTCSS; if the signaling is DCS, the radio scans the DCS.

Press / to change the direction of CTCSS/DCS scan.

#### ◆ Setting the Beat Frequency

Press , the icon  displays on the upper left of the screen. Then press  to select the direction of the beat frequency. The direction of the beat frequency refers to:

##### Positive beat frequency

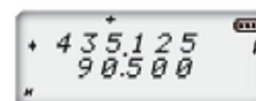

The transmitting frequency is higher than the receiving frequency. When reverse channel is enabled, the receiving frequency is higher than the transmitting frequency.



##### Negative beat frequency



The transmitting frequency is lower than the receiving frequency. When the reverse channel is enabled, the receiving frequency is lower than the transmitting frequency.

### No beat frequency

In the VFO mode, frequency + channel mode or channel name mode, press , the icon  displays at the upper left of the screen. Then press  to select positive, negative or off (please refers to Beat Frequency Settings).

Note: This function is invalid in PT280 Professional Radio mode.

### ◆ Frequency /Channel Scan

In the corresponding mode, press , the icon  displays at the upper left of the screen. Then press  to begin frequency or channel scan.

#### Frequency scan

The scan is available in the VFO mode. This function is used to monitor the signals of each frequency. Press  or digit keys to exit.



#### Channel scan

In channel mode, this function is used to monitor the signals of each channel. Press  or digit keys to exit.



Note:

Frequency scan will scan all the frequencies. The scan conforms to the preset step rule.

Channel scan will scan all the channels except the skip channel. The direction of the scan is from small channel number to large channel number. (See Scan Skip)

The direction of Frequency/channel scan can be changed by pressing  / . When the carrier and signaling to be scanned matches with the radio, the radio stays at this frequency/channel for 15s, and then continues. (See Scan Settings)

### ◆ Channel Scan Skip

In channel name mode or frequency + channel mode, press , the icon  displays at the upper left of the screen. Then press  to set the current channel as Channel Scan Skip. Repeat the above operation to cancel the settings.

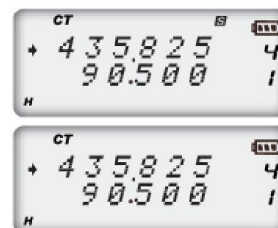



When the screen displays “s”, the current channel will not be scanned;

When the screen does not display “s”, the current channel will be scanned.

Note: In professional radio mode or frequency mode (VFO), this operation is invalid.

### ◆ Priority Scan



In channel mode, press , the icon  displays at the upper left of the screen. Then press  to enter the priority scan. After



scanning 10 channels, the radio returns to scan the priority channel. When the signal is received from the priority channel, the radio stays at the channel until the signal disappears. (See Scan Settings)

Note: This function can only be used when preset by the programming software, or otherwise the radio just performs the traditional scan. When the radio is in the temporary channel (VFO), this function is invalid. (See Priority Scan Settings)

### ◆ High/Low Power

Press , the icon  displays at the upper left of the screen. Then press  to select high/intermediate/low power.

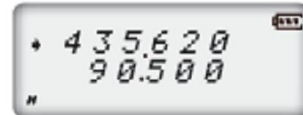

When “H” displays at the down left of the screen, it means high power transmission.





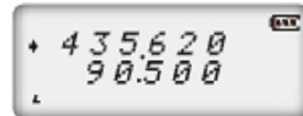

When “H” or “L” does not display at the screen, it means intermediate transmission.

When “L” displays, it means low power transmission.



### ◆ DTMF Encode Check and Settings

Press , the icon  displays at the upper left of the screen. Then press  to display the DTMF data of the current group (16 in total).

Press  /  to select the desired group to check the DTMF data. If DTMF data are not programmed in the group, the screen displays the current group number and “\_\_\_\_\_”.



If the screen displays “\_\_\_\_\_”, press , the icon 

displays at the upper left of the screen. Then press  for 2s, a sound of “Du Du” is heard.

You can edit the DTMF data with the keypad now.

After that, press side button [PF2] to dial the DTMF number and save the data.

### ◆ Sending DTMF Signal Manually

Method 1: press and hold [PTT] button, and then input the desired keys with the keypad.

Method 2: press and hold [PTT] button, input the first digit, and then release the button. The radio will stay at the transmission state for 2S, input other digits within 2S but do not need to hold [PTT] button. During the transmission of DTMF audio, you can monitor the transmitting audio by hearing the voice coming from the speaker.

### ◆ Sending Selected Call, Group Call and All Call with DTMF Encode

This radio can assign different ID to each channel, which can be programmed by the programming software or manually.

ANI: When the radio receives the matched ANI call, the screen displays the caller's ID. And you can identify which radio is sending the call by this ID.

PTT ID: When the working channel is set the PTT ID, this ID will be sent out either by pressing or releasing the PTT button.

You can assign the different group call codes to different groups (using DTMF characters A, B, C, D, "\*" or "#"). The caller calls different groups by sending out different group codes. The receiver receives the matched ID from the caller to realize all call, group call or selected call.

For example:

Group code is "C". And there are four radios, A, B, C, and D.

Their ID codes are 123, 223, 235 and 355.

If the caller has input 123, 223, 235 or 355 when pressing the PTT button, radio A, B, C or D can receive the call respectively.

If the caller has input "C23" while pressing the PTT button, radio A and B receive the call.

If the caller has input "CC5" while pressing the PTT button, radio C and D receive the call.

If the caller has input "CCC" while pressing the PTT button, all the radios receive the call.

### ◆ Kill/Waken

By sending out the particular code (code to kill the radio), one radio can kill the other radio, i.e. disable all the key operations and functions. When the radio is killed, the screen displays "KILL".

By sending out the kill code + "#", one radio can waken the other radio. E.g. Kill code is "2267". Thus, send "2267#" to waken the radio, and the screen displays "WAKEN" when enabled.

Note: Kill code must be edited by the programming software, and cannot exceed 16 digits.



### ◆ Stun/Waken



By sending out the particular code (code to stun the radio), one radio can stun the other radio, i.e. temporarily disable all the key operations and functions except receive the call. When the radio is stunned, the screen displays "STUN".

By sending out the stun code + "#", one radio can waken the other radio. E.g. Stun code is "2268". Thus, send "2268#" to waken the radio, and the screen displays "WAKEN" when enabled.

Note: Stun code must be edited by the programming software, and cannot exceed 16 digits. When the radio wakens, all the operation and functions enable.



## ◆ Reverse Channel/Talk around

Press , the icon  displays at the upper left of the screen. Then press  for one second, Reverse channel or Talk around enables. Repeat the operation above to disable the function.

Note: When Reverse channel is enabled, perform the operation to turn on or off the function, or otherwise it is to turn on or off the talk around function.

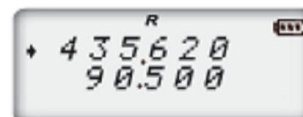

When “R” appears on the screen, it indicates that reverse channel function is enabled on the current channel. In this state, the transmitting frequency and receiving frequency is reversed. If there is CTCSS/DCS signaling, it will be reversed too.



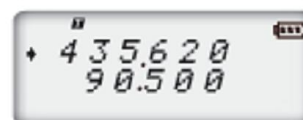

When “T” appears on the screen, it indicates that talk around function is enabled on the current channel. In this state, the radio transmits with the receiving frequency. If there is CTCSS/DCS signaling, the transmit signal will be encoded by the CTCSS/DCS decode.

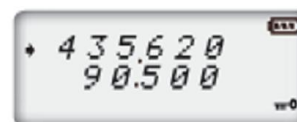

## ◆ Keypad Lock

In order to avoid of misoperation, you can lock the keypad. In the standby state, press , the icon  displays at the upper left of





the screen. Then press  for 2S to lock the keypad. Repeat the operation above to unlock the keypad.



Note: When keypad is locked, all the keys are useless except [PTT] / [PF1]/ [PF2]/ [A].

## ■ Operation and Introduction of Channel Functions

Operations of channel functions temporarily change the function of the current channel. Cut down the power supply or change the channel function, the settings will not be saved.

In the frequency + channel/channel name or frequency mode, the basic operation is as follows:



\* Press , the icon  displays at the upper left of the screen. Then press  to enter Function Menu;

\* Press  /  to select the desired function item;

\* Press  to set this function;

\* Press  /  to select the desired settings;

\* Press  to return to the previous menu, and press  to confirm and exit it.



Note: When the radio is in professional radio mode, operation of pressing  and  is



invalid. In VFO mode, power off or change frequency, the above settings will not be saved.

### ◆ CTCSS/DCS Decode

When this function is enabled, you can ignore the call from the irrelevant radios which use the same frequency with you.

Press , the icon  displays at the upper left of the screen. Then press  to enter Function Menu;

Press  /  to select No. 1 Function, the screen displays "R-CDC";

Press  to set this function;

Press  to select CTCSS, DCS or OFF. If selecting DCS, you can press

 to select DCS normal/inverse code;



Press  /  to select the desired decoding signaling CTCSS/DCS;



CTCSS: 67Hz-254.1Hz, 50 groups. Default setting is 67Hz;

DCS: 017N-765I, 232 groups. N is the normal code; I is the inverse code. Default setting is 017N.



### ◆ CTCSS/DCS Encode



Press , the icon  displays at the upper left of the screen. Then press  to enter Function Menu;

Press  /  to select No. 2 Function, the screen displays "T-CDC";

Press  to set this function;

Press  to select CTCSS, DCS or OFF. If selecting DCS, you can

press  to select DCS normal/inverse code;

Press  /  to select the desired encoding signaling

CTCSS/DCS;



CTCSS: 67Hz-254.1Hz, 50 groups. Default setting is 67Hz;

DCS: 017N-765I, 232 groups. N is the normal code; I is the inverse code. Default setting is 017N.





### ◆ CTCSS/DCS Decode and Encode Synchronization

When this function is enabled, you can synchronize CTCSS/DCS decode and encode.

Press , the icon  displays at the upper left of the screen. Then press  to enter

Function Menu;

Press  /  to select No. 3 Function, the screen displays "C-CDC";



Press  to set this function;

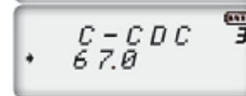

Press  to select CTCSS, DCS or OFF. If selecting DCS, you can

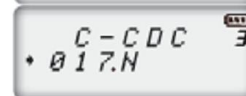

press  to select DCS normal/inverse code;

Press  to select the desired encoding signaling CTCSS/DCS;

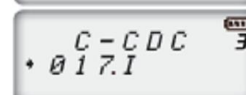

CTCSS: 67Hz-254.1Hz, 50 groups. Default setting is 67Hz;

DCS: 017N-765I, 232 groups. N is the normal code; I is the inverse code. Default setting is 017N.

### ◆ Beat Frequency

This function is used to apply the repeater in the communication, i.e. the repeater receives the signal with one frequency, and transmits the signal with another frequency; the margin between these two frequencies is the beat frequency.



Press , the icon  displays at the upper left of the screen.



Press  to enter Function Menu;

Press  /  to select No. 4 Function, the screen displays "OFFSET";

Press  to set this function;

Press  /  to select the desired beat frequency;

Frequency range is 00-70MHz. Default setting is 5MHz.

### ◆ Wide/Narrow Band

You can set the radio to work as wide or narrow band referring to the requirements of different countries.

Press , the icon  displays at the upper left of the screen.

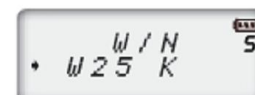

Press  to enter Function Menu;



Press  /  to select No. 5 Function, the screen displays "W/N";



Press  to set this function;

Press  /  to select the desired settings;

Options: 25K (wide band), 20K (intermediate band), 12.5K (narrow band). Default setting is 25K.

#### ◆ Reverse Frequency or Talk around

Press  and the icon  displays at the upper left of the screen. Then press  to enter Function Menu;

Press  /  to select No. 6 Function, the screen displays "REV/TA";



Press  to set this function;



Press  /  to select the desired settings;



REV: refer to reverse frequency. TA: refer to talk around.



Note: If the current channel is set one of the functions, you can enable the function by pressing

 and then  in the standby state.

#### ◆ Voice Encryption (prevent from illegal listening)

This function is a special treatment to the voice, which is used to encrypt the communication so that the radios working with the same frequency cannot hear the communication but only noises.

Press  and the icon  displays at the upper left of the screen. Then press  to enter Function Menu;

Press  /  to select No. 7 Function, the screen displays "SCREM";



Press  to set this function;



Press  /  to select the desired settings;



ON: voice encryption is enabled; OFF: voice encryption is disabled. Default setting is OFF.



When this function is enabled, the communication can only continue when the other party also enables voice encryption function.

#### ◆ Voice Companding (decrease the noise and improve the communication clearance)

The two communication parties all enable the voice companding function, so that the noise will be decreased.

Note: The two communication parties must all enable this function so as to use it.

Press  and the icon  displays at the upper left of the screen. Then press  to enter Function Menu;

Press  /  to select No. 8 Function, the screen displays "COMP";



Press  to set this function;







Press  /  to select the desired settings;

ON: voice companding is enabled; OFF: voice companding is disabled. Default setting is OFF.

### ◆ Busy Channel Lockout

Enabled, the radio cannot transmit on the busy channel. This can avoid of interfering the other radio which uses the same working frequency as you. When the current channel is busy and you press the [PTT] button, the radio will send out an alarm. And then the radio returns to receive signal.

Press  and the icon  displays at the upper left of the screen. Then press  to enter Function Menu;

Press  /  to select No. 9 Function, the screen displays "BUSY";



Press  to set this function;



Press  /  to select the desired settings;





BCL: Carrier busy lockout. The radio prohibits transmitting when receiving the matched carrier on the current channel.



BTL: Signaling busy lockout. The radio prohibits transmitting when receiving the matched carrier but different CTCSS/DCS on the current channel.

OFF: disable the function. Default setting is OFF.

### ◆ Enable/Disable Optional Signaling

The function of the optional signaling is similar to CTCSS/DCS. Besides, selected signaling can also realize ANI, PTT ID, all call, group call, selected call, stun, kill, waken and etc.

Press  and the icon  displays at the upper left of the screen. Then press  to enter Function Menu;

Press  /  to select No. 10 Function, the screen displays "OPTSIG";



Press  to set this function;





Press  /  to select the desired settings;



ON: enable this function; OFF: disable this function. Default setting is OFF.

Note: The optional signaling of this radio is DTMF signaling.

### ◆ Signaling Relation

You can set the way of receiving and transmitting in this function.

Press  and the icon  displays at the upper left of the screen. Then press  to enter Function Menu;

Press  /  to select No. 11 Function, the screen displays "SIGNAL";

Press  to set this function;

Press  /  to select the desired settings;



OR: The call can be heard when the radio receives the matched CTCSS/DCS or the optional signaling.

AND: The call can be heard only when the radio receives the matched CTCSS/DCS and the optional signaling.



Default setting is OR.

Note: The optional signaling of this radio is DTMF signaling.

### ◆ PTT ID

Press  and the icon  displays at the upper left of the screen.

Then press  to enter Function Menu;

Press  /  to select No. 12 Function, the screen displays "PTT-ID";

Press  to set this function;

Press  /  to select the desired settings;



OFF: disable the function

BOT: begin, and press [PTT] to send out a string of DTMF encode.



EOT: end, and release [PTT] to send out a string of DTMF encode.

BOTH: from beginning to end, a string of DTMF encode are send out by pressing and releasing [PTT] button.

Default setting is OFF.

### ◆ Tx Prohibit

Enabled, the radio cannot transmit but only receive signal on the current channel.

Press  and the icon  displays at the upper left of the screen. Then press  to enter Function Menu;

Press  /  to select No. 13 Function, the screen displays "TX-IHB";

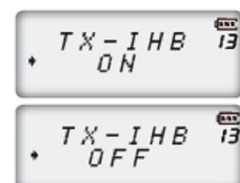



Press  to set this function;



Press  /  to select the desired settings;

ON: enable the function; OFF: disable the function. Default setting is OFF.

### ◆ **Whisper**

Enabled, you can whisper with the microphone, and the other party can hear a louder voice.

Press  and the icon  displays at the upper left of the screen. Then press  to enter Function Menu;

Press  /  to select No. 14 Function, the screen displays “WHISPE”;

Press  to set this function;

Press  /  to select the desired settings;

ON: enable the function; OFF: disable the function. Default setting is OFF.



## ■ **Operation and Introduction of Radio Functions**

The settings of the radio functions can be adjusted and saved in any mode. The basic operation is as follows:

Press [PF2] to turn on the radio, and then hold this key for 3S to enter Radio Function Menu;

Press  /  to select the desired submenu;

Press  to enter this submenu;

Press  /  to select the desired setting;



Press  or  to confirm and exit.

### ◆ **Voice Annunciation**

Enabled, the radio will annunciate the input digits or the state the radio is in when you input the frequency or channel number with the keypad.

There are two options to be chosen: Chinese annunciation and English annunciation.

Press [PF2] to turn on the radio, and then hold this key for 3S to enter Radio Function Menu;

Press  /  to select No.1 Function and the screen displays “VOICE”;



Press  to enter this function;

Press  /  to select the desired setting;

OFF: disable this function; CHN: Chinese annunciation; ENG: English annunciation. Default setting is CHN.

### ◆ Timeout Timer

This function is used to prevent the radio from continuously transmitting so as to cause the overheating of the rear side of the radio. When the time of the radio transmits exceeds the preset time, the radio will be stopped to transmit forcibly, and an alarm is heard.

Press [PF2] to turn on the radio, and then hold this key for 3S to enter Radio Function Menu;

Press  /  to select No.2 Function and the screen displays "TOT";

Press  to enter this function;

Press  /  to select the desired setting;

Options: 15~240S, 4 minutes in total. The interval between each level is 15S.

OFF: disable this function. Default setting is OFF.



### ◆ VOX

Enabled, the radio can transmit the signal by VOX but not by pressing [PTT] button. You must first connect the suitable earphone to the radio before applying this function.

Press [PF2] to turn on the radio, and then hold this key for 3S to enter Radio Function Menu;

Press  /  to select No.3 Function and the screen displays "VOX";

Press  to enter this function;

Press  /  to select the desired setting;

Options: Level 1~3. The higher the level, the louder the voice is needed.

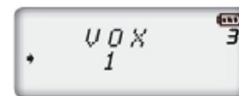

OFF: disable this function. Default setting is OFF.





### ◆ VOX Hold Time

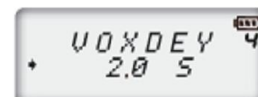

In VOX state, if the radio returns instantly to the receiving mode after sending out a call, the end of the call would not be able to be correctly transmitted due to such a short time. To avoid this, you can preset a VOX hold time to prolong the transmitting time.

Press [PF2] to turn on the radio, and then hold this key for 3S to enter Radio Function Menu;

Press  /  to select No.4 Function and the screen displays "VOXDEY";



Press  to enter this function;



Press  /  to select the desired setting;

Options: 0.5S~5S, 10 levels in total. The interval between each level is 0.5S.  
Default setting is 2S.



### ◆ VOX Alert Tone

Enabled, an alert tone is heard when using VOX to transmit.

Press [PF2] to turn on the radio, and then hold this key for 3s to enter Radio Function Menu;

Press  /  to select No.5 Function and the screen displays “VOXTON”;

Press  to enter this function;

Press  /  to select the desired setting;

OFF: disable this function; ON: enable the function.  
Default setting is OFF.





### ◆ Step Frequency

In the frequency mode, the input frequency or frequency scan will be limited by the step frequency.

Press [PF2] to turn on the radio, and then hold this key for 3S to enter Radio Function Menu;

Press  /  to select No.6 Function and the screen displays “STEP”;

Press  to enter this function;

Press  /  to select the desired setting;

Options: 5K, 6.25K, 10K, 12.5K, 15K, 20K, 25K, 30K, 50K.  
Default setting is 5K.

Note: This submenu will disappear in the channel mode.



### ◆ Squelch Level

This function is used to set the signal strength. When the signal strength arrives to the certain level, you can hear the other party, or otherwise the radio keeps mute.

Press [PF2] to turn on the radio, and then hold this key for 3S to enter Radio Function Menu;

Press  /  to select No.7 Function and the screen displays “SQL”;

Press  to enter this function;

Press  /  to select the desired setting;

Options: 10 levels. “0” is the lowest level (means always ON).





Default setting is 04.

### ◆ Battery Save

This radio has battery save function, which helps to prolong the working time. When the radio receives carrier or the keys are pressed, the radio exits this mode immediately and return back to the normal state.



Press [PF2] to turn on the radio, and then hold this key for 3S to enter Radio Function Menu;

Press  /  to select No.8 Function and the screen displays "SAVE";



Press  to enter this function;



Press  /  to select the desired setting;

OFF: disable this function

1:1 the ratio between normal working state and battery save working state is 1:1

1:2 the ratio between normal working state and battery save working state is 1:2

1:4 the ratio between normal working state and battery save working state is 1:4

Default setting is 1:2

Note: The higher the ratio, the lower power consumption in the standby state is. But it may cause that the radio misses the small part of the signal sent by the other party at the beginning.

### ◆ Backlight

The backlight can be set as Always ON, Always OFF and Auto.

Press [PF2] to turn on the radio, and then hold this key for 3S to enter Radio Function Menu;

Press  /  to select No.9 Function and the screen displays "LIGHT";



Press  to enter this function;



Press  /  to select the desired setting;



AUTO: automatically on. The backlight turns on automatically and turns off after a short while automatically.



ON: always on; OFF: always off.

Default setting is AUTO.

### ◆ Color of Backlight

There are three colors to be chosen.



Press [PF2] to turn on the radio, and then hold this key for 3S to enter Radio Function Menu;

Press  /  to select No.10 Function and the screen displays "COLOR";



Press  to enter this function;



Press  /  to select the desired setting;

ORG: orange backlight

BLUE: blue backlight



PUR: purple backlight

Default setting is PUR.

### ◆ Scan Temporary Stay Time

This function has three options.



Press [PF2] to turn on the radio, and then hold this key for 3S to enter Radio Function Menu;

Press  /  to select No.11 Function and the screen displays "SCANTM";



Press  to enter this function;



Press  /  to select the desired setting;



5ST: When receiving the matched signal, the radio stays at this channel for 5s and then continues scanning.

10ST: When receiving the matched signal, the radio stays at this channel for 10s and then continues scanning.

15ST: When receiving the matched signal, the radio stays at this channel for 15s and then continues scanning.

Default setting is 15ST.

### ◆ Display Mode

There are Channel No. mode, Channel frequency + channel No. mode and Channel name + Channel No. mode to be chosen.



Press [PF2] to turn on the radio, and then hold this key for 3S to enter Radio Function Menu;

Press  /  to select No.12 Function and the screen displays "DSP";



Press  to enter this function;



Press  /  to select the desired setting;



FREQ: display channel frequency + channel No. (Non-professional radio mode, press the specific key to switch to VFO mode)

CH: display channel number (Professional radio mode. Note: If the radio is programmed to professional radio mode and selected to be locked by the programming software, the radio cannot return to the non-professional mode by pressing the key manually.)

NAME: display channel name + channel No. (Non-professional mode, press the specific key to switch to VFO mode)

Default setting is FREQ.

### ◆ Single Tone Pulse Frequency

This function is used to waken the repeater activated by the single tone pulse with certain volume. If the repeater is ON, single tone pulse is not needed.



There are four frequency options. During transmission, press [PF1] to hear the pulse signal you have chosen.

Press [PF2] to turn on the radio, and then hold this key for 3S to enter Radio Function Menu;

Press  /  to select No.13 Function and the screen displays "TBST";



Press  to enter this function;

Press  /  to select the desired setting;

Four frequency options: 1000Hz, 1450Hz, 1750Hz, 2100Hz.

Default setting is 1750Hz.



### ◆ DTMF Transmitting Time

Press [PF2] to turn on the radio, and then hold this key for 3S to enter Radio Function Menu;

Press  /  to select No.14 Function and the screen displays "DTMFSD";

Press  to enter this function;



Press  /  to select the desired setting;

50MS: every audio signal of DTMF transmits for 50MS and then stops 50MS

100MS: every audio signal of DTMF transmits for 100MS and then stops 100MS

150MS: every audio signal of DTMF transmits for 150MS and then stops 150MS

200MS: every audio signal of DTMF transmits for 200MS and then stops 200MS

250MS: every audio signal of DTMF transmits for 250MS and then stops 250MS

300MS: every audio signal of DTMF transmits for 300MS and then stops 300MS

350MS: every audio signal of DTMF transmits for 350MS and then stops 350MS

400MS: every audio signal of DTMF transmits for 400MS and then stops 400MS

450MS: every audio signal of DTMF transmits for 450MS and then stops 450MS

500MS: every audio signal of DTMF transmits for 500MS and then stops 500MS

Default setting is 100MS.

### ◆ BEEP Tone Volume

Press [PF2] to turn on the radio, and then hold this key for 3S to enter Radio Function Menu;

Press  /  to select No.15 Function and the screen displays "VOL-BP";

Press  to enter this function;



Press  /  to select the desired setting;



Options: 1~5, 5 levels in total.

Default setting is level 2.

### ◆ Priority Channel



During the priority scan, if there is a priority channel, the radio will scan back to this channel after scanning every 10 channels. When this priority channel appears carrier, the scan stays at this channel until the carrier disappears.

Press [PF2] to turn on the radio, and then hold this key for 3S to enter Radio Function Menu;

Press  /  to select No.16 Function and the screen displays "PRI-CH";

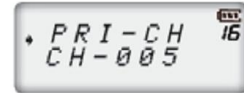
Press  to enter this function;



Press  /  to select the desired setting;

Options: 1~128 channels.

OFF: disable this function

Default setting is OFF.

Note: The priority channel can only be the programmed channel; channels which are skipped in the scan or unprogrammed cannot be selected.

### ◆ Battery Voltage Check

Press [PF2] to turn on the radio, and then hold this key for 3S to enter Radio Function Menu;

Press  /  to select No.17 Function and the screen displays "V-BATT"





and the current battery voltage.

### ◆ Restore Factory Settings

This function is used to restore the factory settings due to the misoperation of the radio so that cause the radio unable to use it.

Press [PF2] to turn on the radio, and then hold this key for 3S to enter Radio Function Menu;

Press  /  to select No.18 Function and the screen displays "RESET";



Press  to enter this function;

Press  /  to select the desired channel;



FACT? : restore the factory settings (restore the frequency, signaling and functions settings to the factory settings)

INIT? : restore the radio function settings (the radio function settings (see the above) restores to factory settings, and the frequency, signaling, channel function settings are unchanged.)

Press  to confirm it.

## ■ Programming Software Installation

(The installation in this manual is set up on WINDOWS XP system.)

1. Double click "QPS280 setup.exe" and install the software step by step.
2. After installation, click the "Start" icon → select "All programs" → find "QPS280" → find and click "USB to COM Port". Then install the USB driver step by step.
3. Connect one end of programming cable to PC USB port, another end to the radio.
4. Double click "QPS280" icon on the desktop or click "Start" → "All programs" → "QPS280" → "QPS280" to start the software. (See figure 1)
5. Select the suitable "COM Port" (See figure 2), click "OK", then you can start to use it.

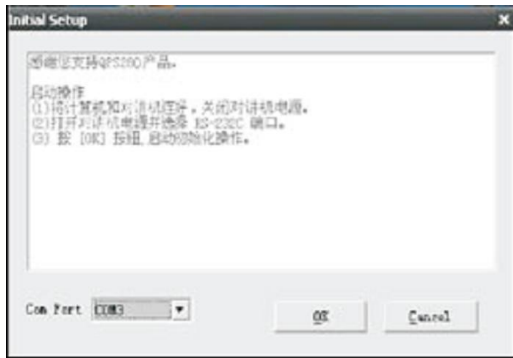

Figure 1

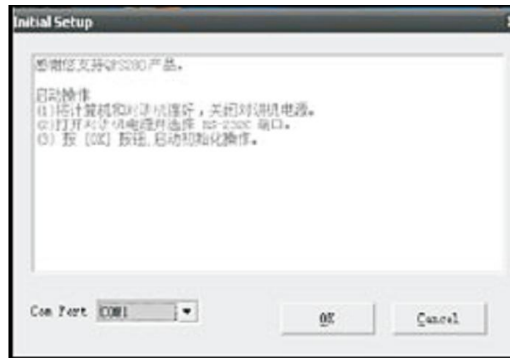

Figure 2

Note 1:

On one PC, if the USB programming cable connects to the different USB port, the number of the COM port will be different.

Please power on the radio before connecting it to PC. Do not turn on or off the radio when connecting with PC, otherwise the program software cannot be used. Then please close the software, plug off the programming cable, and then plug in the cable again and start the software. The software can be used it again. Thus, you'd better connect the radio to the PC after powering on the radio.

Note 2:

This program software can identify its corresponding radio. Therefore, during the first run of this software, PT280 must be connected; otherwise this software cannot be used.

## ■ Specifications

General specification	
Frequency range	VHF: 136-174MHz UHF: 350-390MHz
	UHF: 400-480MHz UHF: 450-520MHz

No. of channels	128
Channel spacing	25KHz (Broadband), 20KHz (intermediate band), 12.5 (Narrow band)
Step rule	5KHz, 6.25KHz
Voltage	7.4V DC $\pm$ 20%
Battery endurance	More than 14 hours (1500mAH) (5-5-90)
Frequency stability	$\pm$ 2.5ppm
Working temperature	-20-+55°C
Dimension	195*56*30mm (with battery and antenna)
Weight	185g (with battery and antenna)

<b>Rx part (ETSI EN 300 086 Standard Test)</b>		
	Broad band	Narrow band
Sensitivity (12dB SINAD)	$\leq$ 0.25 $\mu$ V	$\leq$ 0.35 $\mu$ V
Adjacent channel selectivity	$\geq$ 70dB	$\geq$ 60dB
Intermodulation	$\geq$ 65dB	$\geq$ 60dB
Fake signal response	$\geq$ 70dB	$\geq$ 70dB
Audio response	+1~-3dB (0.3~3KHz)	+1~-3dB (0.3~2.55KHz)
SINAD	$\geq$ 45dB	$\geq$ 40dB
Audio distortion	$\leq$ 5%	
Audio output power	1000mW/(10%)	

<b>Tx part (ETSI EN 300 086 Standard Test)</b>		
	Broad band	Narrow band
Output power	5W/2W/0.5W	
Modulation	16K $\Phi$ F3E	11K $\Phi$ F3E
Adjacent channel selectivity	$\geq$ 70dB	$\geq$ 62dB
SINAD	$\geq$ 40dB	$\geq$ 36dB
Tx clusters and harmonics	$\leq$ -36dB	$\leq$ -36dB
Audio response	+1~-3dB (0.3~3KHz)	+1~-3dB (0.3~2.55KHz)
Audio distortion	$\leq$ 5%	

## ■ Troubleshooting

Problem	Causes and Solutions
The radio cannot be switched on or no display after being switched on.	<ul style="list-style-type: none"> <li>* The battery power may be insufficient. Please recharge or replace the battery pack.</li> <li>* The battery pack may not be installed properly. Please remove the battery pack and install again.</li> <li>* The power switch may be broken. Please contact the authorized local dealer for servicing.</li> <li>* The battery touch sheet may be broken. Please contact the authorized local dealer for servicing.</li> </ul>
The battery power consumes quickly after charging.	<ul style="list-style-type: none"> <li>* The battery life is finished. Please replace it with a new battery pack.</li> </ul>
The radio cannot scan.	The channels are not added to the scan list when the radio is programmed. (only operated by professional technicians)
Only noise is heard on all channels after programming.	The squelch is ON during the programming. (only operated by professional technicians)
Cannot hear any voice after using the earphone for a period of time.	The earphone jack is broken. (Please contact the authorized local dealer for servicing.)
The communication distance shortens and the sensitivity decreases.	<ul style="list-style-type: none"> <li>* Make sure the antenna is OK, and the antenna is well connected with the radio.</li> <li>* The antenna connector may be broken. The radio may be in low power state. (Otherwise please contact the authorized local dealer for servicing.)</li> </ul>
Cannot talk to or hear other group members.	<ul style="list-style-type: none"> <li>* Make sure the frequency/channel is the same as that of your group members.</li> <li>* Make sure the CTCSS/DCS/DTMF signal is the same as that of your group members.</li> <li>* The radio is out of effective communication range.</li> </ul>
The radio cannot switch on or always turn off automatically.	The battery touch sheet may be distorted or split.
The receiving voice is small or intermittent.	Make sure the small hole of MIC is not blocked. (Otherwise please contact the authorized local dealer for

	servicing.)
The signal is intermittent and carries very loud noise.	* The communication is out of the range or the signal is blocked by the high buildings. * Intermediate filter (450) may be broken. Please contact the authorized local dealer for servicing.
The voice from the speaker is smaller after using for a period of time or there are noises from the speaker.	Make sure that the speaker net is OK, and there is no iron powder or other things on the speaker diaphragm. (Please contact the authorized local dealer for servicing.)
The radio can receive the call but cannot transmit.	Check [PPT] button.
The LED indicator lights green during receiving, but no voice is heard.	* Check out the volume is loud enough. * The speaker may be broken. Please contact the authorized local dealer for servicing. * The earphone jack may be broken. Please contact the authorized local dealer for servicing. * The volume switch may be broken.

## ■ Appendix 1 DCS Frequency List

1	017	18	073	35	165	52	261	69	356	86	464	103	632
2	023	19	074	36	172	53	263	70	364	87	465	104	645
3	025	20	114	37	174	54	265	71	365	88	466	105	654
4	026	21	115	38	205	55	266	72	371	89	503	106	662
5	031	22	116	39	212	56	271	73	411	90	506	107	664
6	032	23	122	40	<b>217</b>	57	274	74	412	91	516	108	703
7	036	24	125	41	223	58	<b>305</b>	75	413	92	523	109	712
8	043	25	131	42	225	59	306	76	423	93	526	110	723
9	047	26	132	43	226	60	311	77	<b>425</b>	94	532	111	731
10	050	27	134	44	243	61	315	78	431	95	<b>534</b>	112	732
11	051	28	<b>135</b>	45	244	62	325	79	432	96	546	113	734
12	053	29	143	46	245	63	331	80	445	97	565	114	743
13	054	30	145	47	246	64	332	81	446	98	606	115	754
14	<b>055</b>	31	152	48	251	65	343	82	452	99	612	116	<b>765</b>
15	065	32	155	49	252	66	<b>345</b>	83	454	100	624		
16	071	33	156	50	<b>254</b>	67	346	84	455	101	627		
17	072	34	162	51	255	68	351	85	462	102	631		

Note:



1. N refers to normal code, I refers to inverse code. There are 232 groups in total.
2. The digits in bold is non-standard sub-audio frequency.

## ■ Appendix 2 CTCSS Frequency List

1	67.0	11	94.8	21	131.8	31	171.3	41	203.5
2	69.3	12	97.4	22	136.5	32	173.8	42	206.5
3	71.9	13	100.0	23	141.3	33	177.3	43	210.7
4	74.4	14	103.5	24	146.2	34	179.9	44	218.1
5	77.0	15	107.2	25	151.4	35	183.5	45	225.7
6	79.7	16	110.9	26	156.7	36	186.2	46	229.1
7	82.5	17	114.8	27	159.8	37	189.9	47	233.6
8	85.4	18	118.8	28	162.2	38	192.8	48	241.8
9	88.5	19	123.0	29	165.5	39	196.6	49	250.3
10	91.5	20	127.3	30	167.9	40	199.5	50	254.1