



# **PT 3300**

## **FM HANDHELD TRANSCEIVER**

### **USER'S MANUAL**

Add: 2/F Bldg. H-3East Industrial Zone ofOverseas Chinese  
Town Nanshan Dist. Shenzhen, P.R.China  
Postcode: 518053  
Tel: +86-755-8609 6076 Fax: +86-755-8609 6130  
E-mail: [export@kirisun.com](mailto:export@kirisun.com)  
Website: <http://www.kirisun.com>

**Kirisun Electronics (Shenzhen) Co., Ltd**





# USER'S MANUAL

## PT2300/3300

### FM HANDHELD TRANSCEIVER

#### Greeting!

We are grateful for your purchase of this  transceiver. We believe  transceivers, which always incorporate the latest technology can bring great convenience to your life and work; we also believe that the quality and functions of BAOTONG transceivers can meet your demands for reliable communication.

To make sure you can get familiar with the functions and proper operating methods of your transceiver, please read this instruction manual carefully.

This Manual is suitable for the PT-3300 FM Transceiver.

#### Caution:

Please read this manual carefully before using this transceiver

- Do not use the transceiver while taking on fuel or while parking in a gasoline service station.
- Do not use the transceiver in the area where government prohibited.
- Do not expose the transceiver to direct sunlight for a long time, or place it close to heating appliances.
- Do not place the transceiver in excessively dusty, humid, and/or dabbng areas, nor on unstable surface
- If the transceiver emits smoke or strange odors, turn it off and remove the battery from the transceiver and promptly contact your local dealer
- The maintaining of transceiver only can be done by professional technician

**Kirisun Electronics (Shenzhen) Co., Ltd**

## CONTENTS







1. Unpacking and Checking Equipments .....	1
Supplied Accessories .....	1
2. Preparation .....	2
Charging the Battery Pack .....	2
Installing/Removing the Battery Pack .....	3
Installing the Antenna .....	3
Installing /Removing the Belt Clip .....	3
Installing the optional Speaker/Microphone .....	3
3. Getting Acquainted .....	4
Exterior figure .....	4
4. Basic operation .....	5
5. Auxiliary functions .....	6
6. Specification .....	9
7. Troubleshooting Guide .....	9

## 1. Unpacking and Checking Equipments

Carefully unpack the transceiver. We recommend that you identify the items listed in the following table before discarding the packing material. If any damage has occurred during shipment, file a claim with the carrier immediately.

### Supplied Accessories

DESCRIPTION	QUANTITY
Antenna	1
Adaptor	1
Wrist Loop	1
Charger	1
Battery	1
Belt Clip	1
USER'S Manual	1

		
Antenna	Adaptor	Wrist Loop
		
Charger	Battery	Belt Clip

## 2. Preparation

### (1) Charging the Battery Pack

- Plug the AC adaptor cable into the adaptor jack located on the rear of the charger; plug the AC adaptor into power socket of 220V/50Hz.
- Slide the battery pack or the transceiver with the battery pack into the charger.
- Make sure the battery pack contacts are in contact with the charging terminals.
- The charger LED turns red and charging begins. After charging the battery for 8 hours, please disconnect it from the charger.

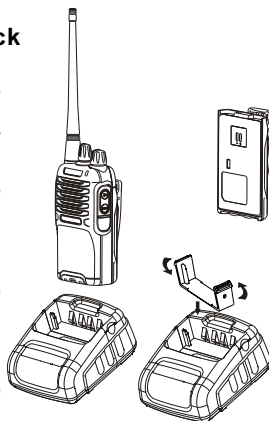

(Figure1)

#### CAUTION:

\*If the battery charging is full, do not charge it again. Overcharging will shorten battery's life or damage it. After purchasing or extended storage (more than 2 months), the battery cannot reach its maximum capacity for the first time recharging. After repeating the charging/discharging the battery two or three times, the capacity will reach its best status.

\* The charge LCD will turn off when charge tests out the battery has been damaged after the beginning of charging 10 minutes.

\* The charge LCD will turn off when the charge is on the protecting status due to over current or short circuit. It should turn off the power and then continue charging.

\* If the charge tests out the temperature of battery is too high (over 60°C), it will stop charging, and the charge LCD turn yellow. After the temperature of battery is drop, remove the battery and re-put, then continue charging.

### (2) Installing/Removing the Battery Pack

- Match the four grooves of the battery pack with the corresponding guides on the back of the transceiver.
- Slide the battery pack along the back of the transceiver until the release latch on the base of the transceiver locks.
- To remove the battery pack, pull back on the release latch and slide the pack away from the transceiver (refer to Figure 2).

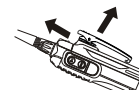
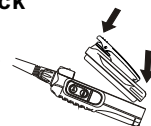

(Figure 2)

#### CAUTION:

- \*Do not short-circuit the battery terminals or dispose the battery into fire.
- \*Never attempt to remove the casing from the battery pack.

### (3) Installing the Antenna

Screw the antenna into the connector on the top of the transceiver by holding the antenna at its base and turn it clockwise until secure (refer to Figure3).



(Figure 3)

### (4) Installing/removing the Belt Clip

Match the belt clip with the corresponding grooves on the battery and slide down the belt clip. To remove the belt clip, slide up the belt clip using your nail or tools (refer to Figure 4).

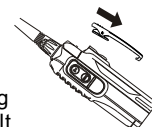

(Figure 4)

### (5) Installing the optional Speaker/Microphone

Remove the rubber cover and insert the speaker-microphone plugs into the SP/MIC jack.

### 3. Getting Acquainted

#### (1) Exterior figure

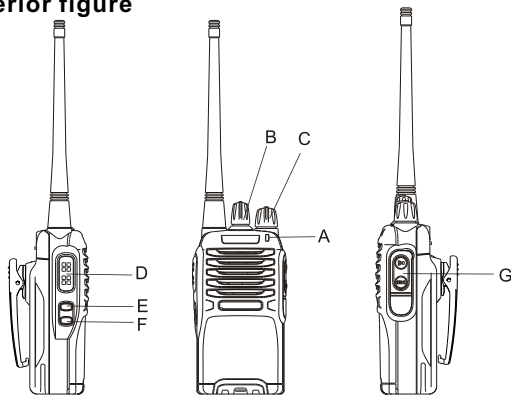

- A** LED Indicator: LED Lights red while transmitting; lights green while receiving a signal; flashes red when the battery voltage is low; lights orange while turning on the radio.
- B** Channel Selector: Rotate to select channel 1-15, and CH16 is scanning channel
- C** Power/Volume Switch: Turn clockwise to switch ON the transceiver; to switch OFF the transceiver, turn counterclockwise until a click sounds; rotate to adjust the volume level.
- D** PTT (Push-to-Talk): To make a call, press and hold the PTT button, then speak into the microphone with normal voice. Release the PTT to receive.
- E** Monitor Button: Press the button for closing the SQUELCH, and release for open
- F** Function key: press this key about 1 second, the transceiver will emit alert with high decibel, press again stop the alert
- G** MIC-SP JACKS: If desired, connect a speaker microphone or ear piece here.

### 4. Basic Operation

#### Switch on



Switch on the transceiver by turning the Power /Volume control clockwise till a click is heard, then the transceiver will be in the state of stand by time, and the orange LED light flashes once and disappears.

#### Adjust the Volume

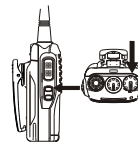

To increase volumes rotate the Power/Volume Control knob clockwise.

#### Select the Channel



Rotate the Channel selector to select your desired channel. If setting the channel selector to CH16 will scan automatic

#### PTT Button

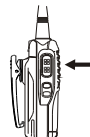

To make a call, press and hold the PTT button then speak into the microphone in your normal speaking voice.

Note: Please keep your mouth away from microphone 3cm-8cm.

## 5. Auxiliary Functions

### ● Monitor

When there is no signal received, the squelch circuit on the transceiver automatically mutes the speaker, so you will not hear background noise. To manually deactivate the squelch, press the Monitor key, which is useful when you want to adjust the volume level or when you need to receive a weak signal.

### ● Alert

When meet sudden or emergent event, press function key about 1 second, the transceiver will emit alert with high decibel, press the key again or PTT, MONI or channel selector to stop it.

### ● High/Low power switch

Switch off the transceiver, and then keep pressing the PTT key, in the meantime turn on the power and continue pressing the PTT key 2 seconds. If heard one warning tone and found the charge LCD turn red, means in high power status. While if heard two warning tone and found the charge LCD turn orange, means in low power status.

### ● Phonic broadcast channel

There are 8 kinds of phonic broadcast channel which including men, women and Chinese-English combination. Firstly switch off the transceiver, and then keep pressing function key, in the meantime turn on the power and continue pressing function key 2 seconds, it will change to another phonic channel.

#### **Noted:**

During switching the phonic broadcast channel, there is one kind in mute, it means no sound phonic broadcast channel.

### ● Scanning function

When the channel selector is on CH16, the transceiver will automatically turn into scanning status. When the transceiver receives the single, it will stick on the current channel, and startup scanning after the channel disappeared 3 seconds.

### ● Time-out Timer

The purpose of the Time-out Timer is to prevent any single person from using a channel for an extended period of time. If you continuously transmit more than limited time, the transceiver will stop transmitting and a tone will sound. To stop the tone, release the PTT button. You can press the PTT button again to resume transmitting. Time limit can be programmed by software by the dealer.

### ● Battery Save

The Battery-Saving function decreases the power consumption when no signal being received or no operations being performed for more than 10 seconds (no keys are being pressed, and no switches are being turned.)

### ● Low battery Warning

Low battery warning alerts you, when the battery needs to be recharged while transmitting. If the battery power goes below a certain value, the LED light will blink red, and the transceiver will stop transmitting.

Replace or recharge the battery pack when battery appears low.

### ● Meeting busy prohibits emitting function

When meeting busy, the prohibitive emitting function switch on (PC program), if not set up CTCSS/DCS, when receive the signal and the speaker switch on, press PTT button can't emitting. If set up CTCSS/DCS, when receive the signal, but CTCSS/DCS is incorrect and the speaker switch off, press PTT button can't emitting. If receive the signal, and CTCSS/DCS also correct and the speaker switch on, press PTT button emitting.

### ● CTCSS/DCS

39 groups of optional standard CTCSS and 83 groups DCS are available (PC programmable). Some channels may have pre-programmed with CTCSS/DCS tones. A CTCSS/DCS tone is a sub-audio tone which allows you to ignore (not hear) calls from other parties who are using the same channel.

When you receive a signal that has a tone different from the one set up in your transceiver, you will not hear the signal. Likewise, signal that you transmit will only be heard by parties whose CTCSS/DCS tones match the tone set in your transceiver.

#### Note:

Although using channels set with CTCSS/DCS tones relieves you from listening to unwanted calls, it does not mean your calls will be private.

### ● Wired Clone

Connect two transceivers with specified copying cable, press monitor and function button in the meantime to switch on, and enter into the “user mode”, hold the Monitor key on the sending transceiver and turn on the power at the same time, the data will be copied from transmitting transceiver to receiving transceiver. For transmitting transceiver, the LED light will blink red during the data transmitting and will turn green if the data transmitting is finished. The LED light will blink green if receiving transceiver receives the data and the green light will disappear if the data transmitting is finished. If the data transmitting fails, the LED light of transmitting transceiver will light red. To restart data cloning, both transceivers need to be turned off and do the above procedures again.

## 6. Specification

Specification	PT3300
Frequency	(1)400~420MHz (2)450~470MHz
RF power	High: 4W/ Low: 1W
Channels	15+1
Power Source	DC 6.0V or DC 7.2V
Dimension	117mm x 56mm x 39mm
Weight	225 g with battery and antenna

## 7. Troubleshooting Guide

NO	Problem	Solution
1	Can not switch on	The battery power is low, and please charge or change it. The battery is not well connected, and just remove the battery and reload it.
2	Standby time is short after charging	Battery life is ending, and please change a new one.
3	Unable to talk with others in the same group	It is out of communication range.
4	Hear other voices (not from the same group) in the channel	Please change the frequency and or CTCSS tone and make sure to change the tone on all the transceivers in your group.