

# IEEE 488.2 Controller Chip

## NAT9914

- Available as RoHS-compliant
- Pin compatible with TI TMS9914A
- Software compatible with NEC  $\mu$ PD7210 or TI TMS9914A controller chips
- Low power consumption
- Meets all IEEE 488.2 requirements
  - Bus line monitoring
  - Preferred implementation of requesting service
  - Will not send messages when there are no Listeners
- Performs all IEEE 488.1 interface functions
- Programmable data transfer rate (T1 delays of 350 ns, 500 ns, 1.1  $\mu$ s, and 2  $\mu$ s)
- Automatic EOS and/or NL message detection
- Direct memory access (DMA)
- Automatically processes IEEE 488 commands and reads undened commands
- TTL-compatible CMOS device
- Programmable clock rate 20 MHz maximum
- Reduces driver overhead
- Does not lose a data byte if ATN is asserted while transmitting data

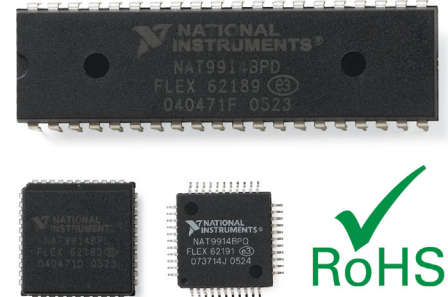

## Description

The NAT9914 IEEE 488.2 controller chip can perform all the interface functions dened by the IEEE Standard 488.1-1987, and also meets the additional requirements and recommendations of the IEEE Standard 488.2-1987. Connected between the processor and the IEEE 488 bus, the NAT9914 provides high-level management of the IEEE 488 bus, signicantly increases the throughput of driver software, and simplifies both the hardware and software design. The NAT9914 performs complete IEEE 488 Talker, Listener, and Controller functions. In addition to its numerous improvements, the NAT9914 is also completely pin compatible with the TI TMS 9914A and software compatible with the NEC  $\mu$ PD7210 and TI TMS9914A controller chips.

## IEEE 488.2 Overview

The IEEE 488.2 standard removes the ambiguities of IEEE 488.1 by standardizing the way instruments and controllers operate. It defines data formats, status reporting, error handling, and common configuration commands to which all IEEE 488.2 instruments must respond in a precise manner. It also denes a set of controller requirements. With IEEE 488.2, you gain the benets of reduced development time and cost because systems are more compatible and reliable. The NAT9914 brings the full power of IEEE 488.2 to the design engineer along with numerous other design and performance benefits, while retaining the 40-pin and 44-pin hardware congurations of the TI TMS 9914A.

## General

The NAT9914 manages the IEEE 488 bus. You program the IEEE 488 bus by writing control words into the appropriate registers. CPU-readable status registers supply operational feedback. The NAT9914 mode determines the function of these registers. On power up or reset, the NAT9914 registers resemble those of the TMS9914A set, with additional registers that supply extra functionality and IEEE 488.2 compatibility. In this mode, the NAT9914 is completely pin compatible with the TI TMS9914A. If you enable the 7210 mode, the registers resemble those of the NEC  $\mu$ PD7210 set, with additional registers that supply extra functionality and IEEE 488.2 compatibility. This mode is not pin compatible with the NEC  $\mu$ PD7210. Figure 4 shows the key components of the NAT9914.

## RoHS Compliance

The NAT9914 is currently available from NI both in a standard package and as a RoHS-compliant chip. The chips can be ordered using the part numbers shown in the Ordering Information box below. The RoHS-compliant parts are identified through the added "F" at the end of the part number and the chip itself is marked with an e3 inside an ellipse to indicate a matte pure tin finish on the leads, in accordance with the marking recommendations defined in JEDEC JESD97.

The RoHS-compliant NAT9914 meets industry requirements for baking and maximum solder reflow temperature. The baking requirements are outlined in JEDEC J-STD-033, and

## IEEE 488.2 Controller Chip

NI recommends using the solder reflow profile as shown in IPC/JEDEC J-STD-020C with a peak temperature of 260 °C, the maximum temperature they can withstand. The Moisture Sensitivity Level (MSL) for the RoHS-compliant surface mount NAT9914 ASICs is 3 (the MSL is not applicable to the NAT9914BPDF through-hole device).

### Ordering Information

NI NAT9914BPD (40-pin DIP package)	
RoHS-compliant .....	NAT9914BPDF-9
Non RoHS-compliant.....	NAT9914BPD-9
Sample kit (RoHS-compliant, 2 ASICs) .....	776730-01
NI NAT9914BPL (44-pin PLCC package)	
RoHS-compliant .....	NAT9914BPLF-27
Non RoHS-compliant.....	NAT9914BPL-27
Sample kit (RoHS-compliant, 2 ASICs).....	776730-02
NI NAT9914BPQ (44-pin QFP package)	
RoHS-compliant .....	NAT9914BPQF-84
Non RoHS-compliant.....	NAT9914BPQ-84
Sample kit (RoHS-compliant, 4 ASICs).....	776730-03

Visit [ni.com](http://ni.com) for a detailed reference manual & specifications.

### BUY NOW!

For complete product specifications, pricing, and accessory information, call (800) 813 3693 (U.S.) or go to [ni.com/gpib](http://ni.com/gpib).

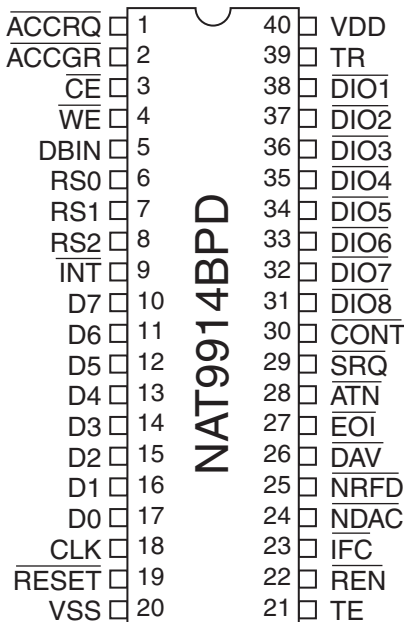

Figure 1. NAT9914BPD Pin Configuration

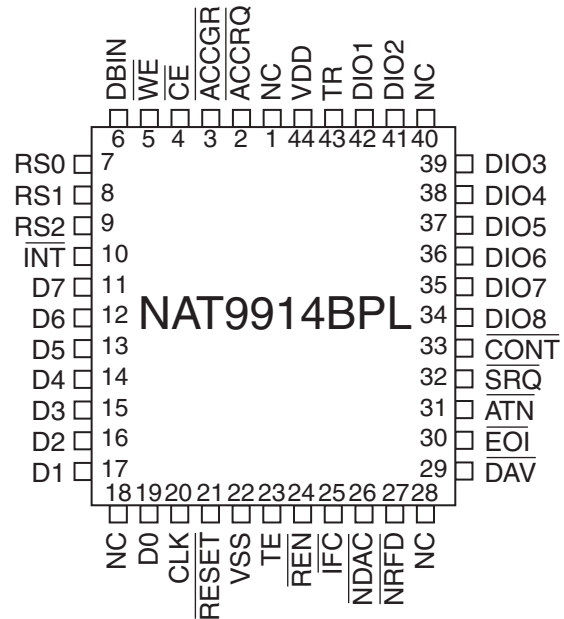

Figure 2. NAT9914BPL Pin Configuration

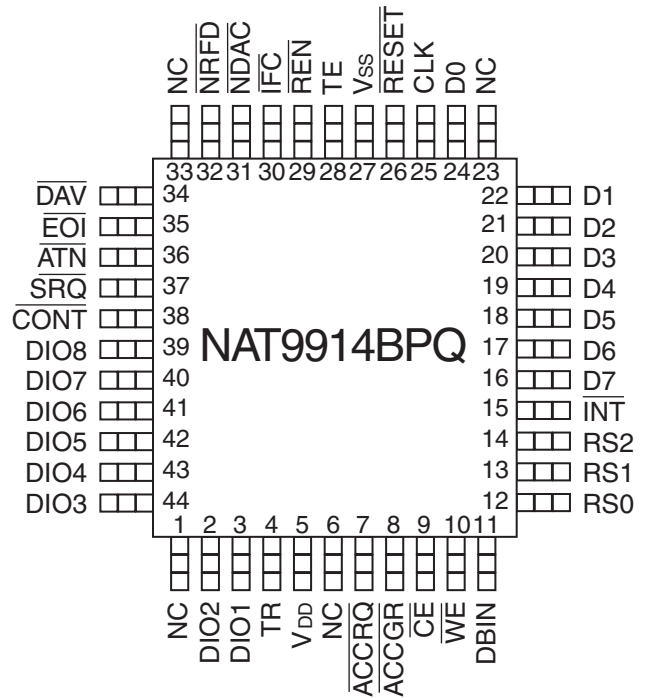

Figure 3. NAT9914BPQ Pin Configuration

## Pin Identification

Pin Number			Mnemonic	Type	Description
PLCC	DIP	QFP			
11, 12, 13, 14, 15, 16, 17, 19	10, 11, 12, 13, 14, 15, 16, 17	16, 17, 18, 19, 20, 21, 22, 24	D(7-0)	I/O'	Bidirectional 3-state data bus transfers commands, data, and status between the NAT9914 and the CPU. <b>DO is the most significant bit.</b>
4	3	9	CE*	I	Chip Enable gives access to the register selected by a read or write operation, and the register selects RS(2-0).
6	5	11	DBIN	I'	With the Data Bus Input, you can place the contents of the register selected by RS(2-0) and CE* onto the data bus D(7-0). The polarity of DBIN is reversed for DMA operation.
5	4	10	WE*	I	The Write input latches the contents of the data bus D(7-0) into the register selected by RS(2-0).
3	2	8	ACCGR*	I'	The Access Grant signal selects the DIR or CDOR for the current read or write cycle.
2	1	7	ACCRQ*	O	The Access Request output asserts to request a DMA Acknowledge cycle.
20	18	25	CLK	I'	The CLK input can be up to 20 MHz.
21	19	26	RESET*	I'	Asserting the RESET* input places the NAT9914 in an initial, idle state.
10	9	15	INT* (OC)	O	The Interrupt output asserts when one of the unmasked interrupt conditions is true. The NAT9914 does not drive INT* high. The INT* pin must be pulled up by an external resistor.
9, 8, 7	8, 7, 6	14, 13, 12	RS(2-0)	I'''	The Register Selects determine which register to access during a read or write operation.
25	23	30	IFC*	I/O','' (OC)	Bidirectional control line initializes the IEEE 488 interface functions.
24	22	29	REN*	I/O' (OC)	Bidirectional control line selects either remote or local control of devices.
31	28	36	ATN*	I/O'	Bidirectional control line indicates whether data on the DIO lines is an interface or device-dependent message.
32	29	37	SRQ*	I/O'	Bidirectional control line requests service from the controller.
34, 35, 36, 37, 38, 39, 41, 42	31, 32, 33, 34, 35, 36, 37, 38	39, 40, 41, 42, 43, 44, 2, 3	DIO(8-1)*	I/O'	8-bit bidirectional IEEE 488 data bus
29	26	34	DAV*	I/O'	Handshake line indicates that the data on the DIO(8-1)* lines is valid.
27	25	32	NRFD*	I/O'	Handshake line indicates that the device is ready for data.
26	24	31	NDAC*	I/O'	Handshake line indicates the completion of a message reception.
30	27	35	EOI*	I/O'	Bidirectional control line indicates the last byte of a data message or executes a parallel poll.
23	21	28	TE	O'	Talk Enable controls the direction of the IEEE 488 data transceiver.

# IEEE 488.2 Controller Chip

Pin Number			Mnemonic	Type	Description
PLCC	DIP	QFP			
43	39	4	TR	0'	Trigger asserts when one of the trigger conditions is satisfied.
33	30	38	CONT*	0'	Controller asserts when the NAT9914 is Controller-In-Charge.
44	40	5	VDD	-	Power pin - +5 V ( $\pm 5\%$ )
22	20	27	VSS	-	Ground pin - 0 V
1, 18, 28, 40	-	1, 6, 23, 33	NC	-	No connect

OC= Open collector.

† The pin contains an internal pull-up resistor of 25 k $\Omega$  to 100 k $\Omega$ .

\* Active low.

†† In controller applications where the CLK signal frequency is > 8 MHz, IFC\* should be pulled up with a 4.7 k $\Omega$  resistor.

††† RS0 and RS1 contain an internal pull-up resistor of 25 k $\Omega$  to 100 k $\Omega$ . RS2 does not contain an internal pull-up or pull-down resistor.

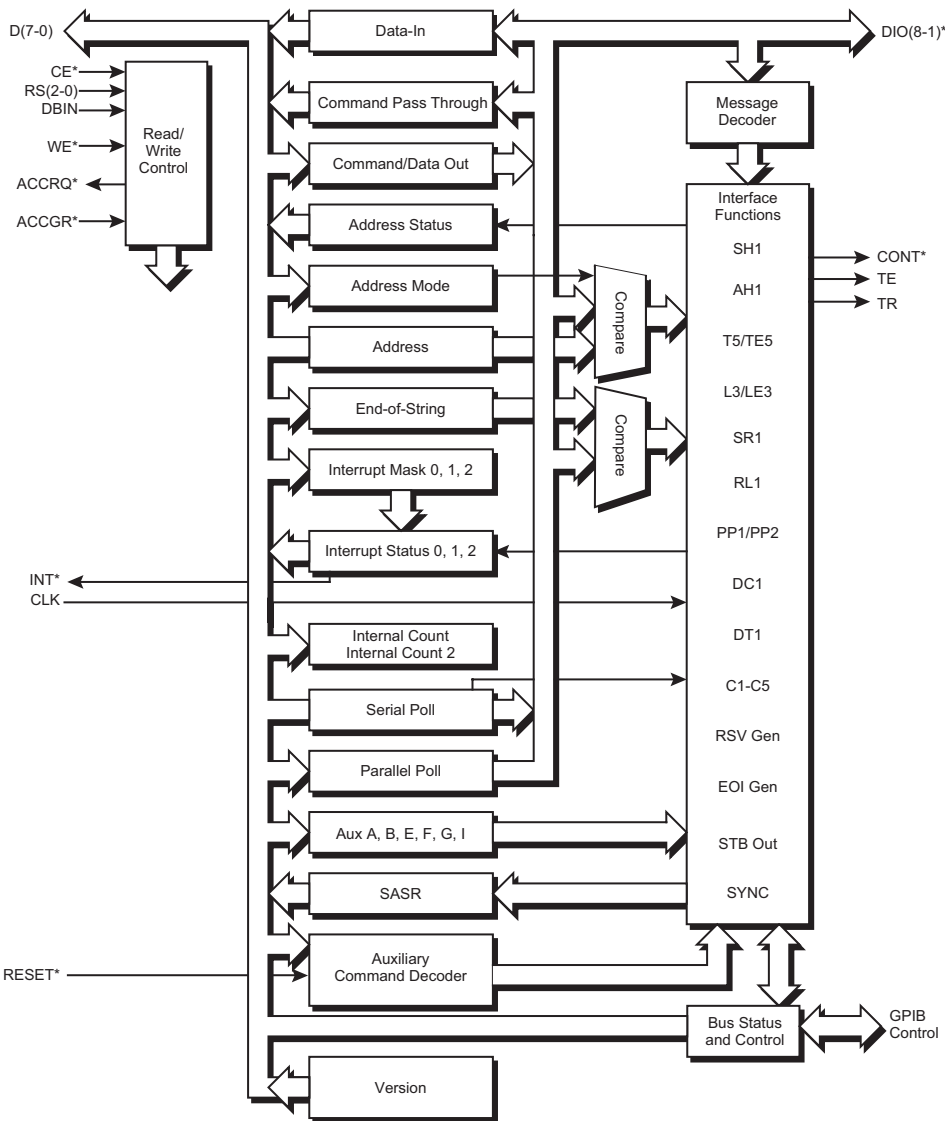

Figure 4. NAT9914 Block Diagram

## 9914 Mode Registers

In 9914 mode, the NAT9914 registers consist of all the TI TMS9914A registers and two types of additional registers – newly dened registers and paged-in registers. The NAT9914 maps the newly dened registers into the unused portion of the 9914 address space. Each paged-in register appears at Offset 2 immediately after you issue an auxiliary page-in command, and it remains there until you page another register into the same space or you issue a reset. The table below lists all the registers in the 9914 register set. See the *NAT9914 Reference Manual* available at ni.com for more information.

### 9914 Register Set

Register	PAGE-IN	RS(2-0)	WE*	DBIN	CE*	ACGR*
Interrupt Status 0	U	0 0 0	1	1	0	1
Interrupt Mask 0	U	0 0 0	0	0	0	1
Interrupt Status 1	U	0 0 1	1	1	0	1
Interrupt Mask 1	U	0 0 1	0	0	0	1
Address Status	U	0 1 0	1	1	0	1
Interrupt Mask 2†	P	0 1 0	0	0	0	1
End-of-String†	P	0 1 0	0	0	0	1
Bus Control†	P	0 1 0	0	0	0	1
Accessory†	P	0 1 0	0	0	0	1
Bus Status	U	0 1 1	1	1	0	1
Auxiliary Command	U	0 1 1	0	0	0	1
Interrupt Status 2†	P	1 0 0	1	1	0	1
Address	U	1 0 0	0	0	0	1
Serial Poll Status†	P	1 0 1	1	1	0	1
Serial Poll Mode	U	1 0 1	0	0	0	1
Command Pass Through	U	1 1 0	1	1	0	1
Parallel Poll	U	1 1 0	0	0	0	1
Data-In	U	1 1 1	1	1	0	1
Data-In	U	X X X	X	0	X	0
Command/Data Out	U	1 1 1	0	0	0	1
Command/Data Out	U	X X X	0	1	X	0

The † symbol denotes features (such as registers and auxiliary commands) that are not available in the TMS9914A.

Notes for the PAGE-IN column:

- U = Page-in auxiliary commands do not affect the register offset.
- P = The register offset is valid only after a page-in auxiliary command.

## 7210 Mode Registers

The NAT9914 registers include all the NEC μPD7210 registers plus two types of additional registers – extra auxiliary registers and paged-in registers. You write the extra auxiliary registers the same as standard μPD7210 auxiliary registers. On issuing an auxiliary page-in command, the paged-in registers appear at the same offsets as existing μPD7210 registers. At the end of the next CPU access, the chip pages out the paged-in registers. The following table lists all the registers in the 7210 mode register set. See the *NAT9914 Reference Manual* available at ni.com for more information.

### 7210 Register Set

Register	PAGE-IN	A(2-0)	WE*	DBIN	CE*	ACGR*
Data-In	U	0 0 0	1	1	0	1
Data-In	X	X X X	X	0	X	0
Command/Data Out	U	0 0 0	0	0	0	1
Command/Data Out	X	X X X	0	1	X	0
Interrupt Status 1	U	0 0 1	1	1	0	1
Interrupt Mask 1	U	0 0 1	0	0	0	1
Interrupt Status 2	U	0 1 0	1	1	0	1
Interrupt Mask 2	U	0 1 0	0	0	0	1
Serial Poll Status	N	0 1 1	1	1	0	1
Serial Poll Mode	N	0 1 1	0	0	0	1
Version	P	0 1 1	1	1	0	1
Internal Counter 2	P	0 1 1	0	0	0	1
Address Status	U	1 0 0	1	1	0	1
Address Mode	U	1 0 0	0	0	0	1
Command Pass Through	N	1 0 1	1	1	0	1
Auxiliary Mode	U	1 0 1	0	0	0	1
Source/Acceptor Status†	P	1 0 1	1	1	0	1
Address 0	N	1 1 0	1	1	0	1
Address	N	1 1 0	0	0	0	1
Interrupt Status 0†	P	1 1 0	1	1	0	1
Interrupt Mask 0†	P	1 1 0	0	0	0	1
Address 1	N	1 1 1	1	1	0	1
End-of-String	N	1 1 1	0	0	0	1
Bus Status†	P	1 1 1	1	1	0	1
Bus Control†	P	1 1 1	0	0	0	1

The † symbol denotes features (such as registers and auxiliary commands) that are not available in the NEC7210.

Notes for the PAGE-IN column:

- U = The page-in auxiliary command does not affect the register.
- N = The register offset is always valid except for immediately after a page-in auxiliary command.
- P = The register is valid only immediately after a page-in auxiliary command.

### Preliminary DC Characteristics

T<sub>A</sub> 0 to 70 °C; V<sub>CC</sub> = 5 V ±5%

Parameter	Symbol	Limits		Unit	Test Condition
		Min	Max		
Voltage input low	V <sub>IL</sub>	-0.5	+0.8	V	–
Voltage input high	V <sub>IH</sub>	+2.0	V <sub>CC</sub>	V	–
Voltage output low	V <sub>OL</sub>	0	0.4	V	–
Voltage output high	V <sub>OH</sub>	+2.4	V <sub>CC</sub>	V	–
Input/output Leakage current	–	-10	+10	µA	without internal pull-up
Input/output Leakage current	–	-200	+200	µA	with internal pull-up
Supply current	–	–	45	mA	–
Output current low	–	–	–	–	–
All pins except ACCRQ	I <sub>OL</sub>	2	–	mA	0.4 V @ I <sub>OL</sub>
ACCRQ	I <sub>OL</sub>	4	–	mA	0.4 V @ I <sub>OL</sub>
Input current low	I <sub>IL</sub>	–	- 0.5	mA	–
Supply voltage	V <sub>DD</sub>	4.75	5.25	V	–

### Capacitance

T<sub>A</sub> 0 to 70 °C; V<sub>CC</sub> = 5 V ±5%

Parameter	Symbol	Limits		Unit	Test Condition
		Min	Max		
Input capacitance	C <sub>IN</sub>	–	10	pF	–
Output capacitance	C <sub>OUT</sub>	–	10	pF	–
I/O capacitance	C <sub>I/O</sub>	–	10	pF	–

### Absolute Maximum Ratings

Property	Range
Supply voltage, V <sub>DD</sub>	-0.5 to +7.0 V
Input voltage, V <sub>I</sub>	-0.5 to V <sub>DD</sub> +0.5 V
Operating temperature, T <sub>OPR</sub>	0 to +70° C
Storage temperature, T <sub>STG</sub>	-40 to +125° C

Comment: Exposing the device to stresses above those listed could cause permanent damage. The device is not meant to be operated under conditions outside the limits described in the operational section. Exposure to absolute maximum rating conditions for extended periods may affect reliability.

### AC Characteristics

T<sub>A</sub> 0 to 70 °C; V<sub>CC</sub> = 5 V ±5%

Parameter	Symbol	Limits		Unit	Test Condition
		Min	Max		
Address hold from $\overline{CE}$ , $\overline{WE}$ , and DBIN	t <sub>AH</sub>	0	–	ns	–
Address setup to $\overline{CE}$ , $\overline{WE}$ , and DBIN	t <sub>AS</sub>	0	–	ns	–
Data float from $\overline{CE}$ or DBIN	t <sub>DF</sub>	–	20	ns	–
Data delay from DBIN↓	t <sub>DR</sub>	–	75	ns	ACCRQ=0
ACCRQ unassertion	t <sub>DU</sub>	–	20	ns	–
Data delay from $\overline{CE}$ ↓	t <sub>RD</sub>	–	80	ns	ACCRQ=1
$\overline{CE}$ recovery width	t <sub>RR</sub>	80	–	ns	–
$\overline{CE}$ pulse width	t <sub>RW</sub>	80	–	ns	–
Data hold from $\overline{WE}$ ↑	t <sub>WH</sub>	0	–	ns	–
Data setup to $\overline{WE}$ ↑	t <sub>WS</sub>	60	–	ns	–

### Notes

- t<sub>AS</sub> is the setup time to  $\overline{CE}$ ↓ or  $\overline{WE}$ ↓, whichever is later.
- t<sub>AH</sub> is the hold time from  $\overline{WE}$ ↑ or  $\overline{CE}$ ↑, whichever is earlier.

## Timing Waveforms

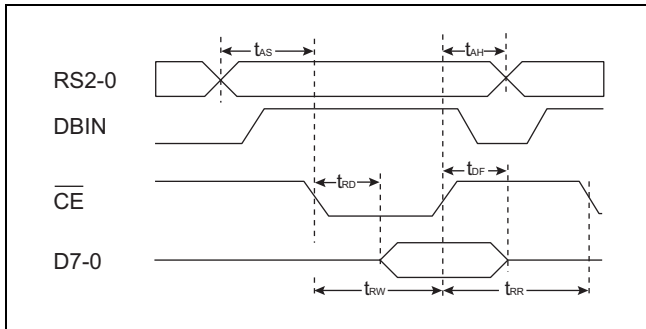

Figure 5. CPU Read

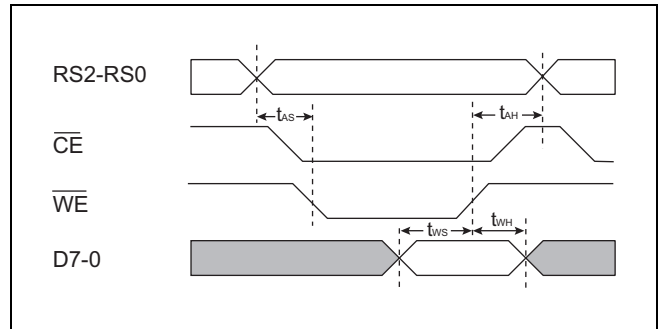

Figure 7. CPU Write

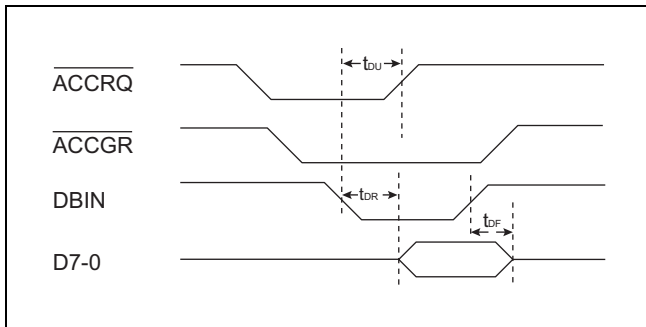

Figure 6. DMA Read

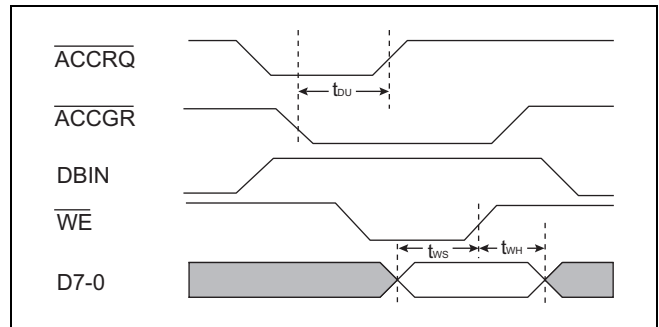

Figure 8. DMA Write

Source Handshake

Parameter	Symbol	Limits (ns)		Test Condition
		Min	Max	
NDAC↑ to DAV↑	$t_{ND}$	-	40	-
NDAC↑ to INT↓ or ACCRQ↓	$t_{NI}$	-	40	INT(DOIE Bit=1) ACCGR (DMAO Bit=1)
WE↑ to DAV↓	$t_{WD}$	2000	2180	2 $\mu$ s T1, 5MHz
WE↑ to DAV↓	$t_{WD}$	1200	1380	1.1 $\mu$ s T1, 5MHz
WE↑ to DAV↓	$t_{WD}$	600	780	500 ns T1, 5MHz
WE↑ to DAV↓	$t_{WD}$	400	580	350 ns T1, 5MHz

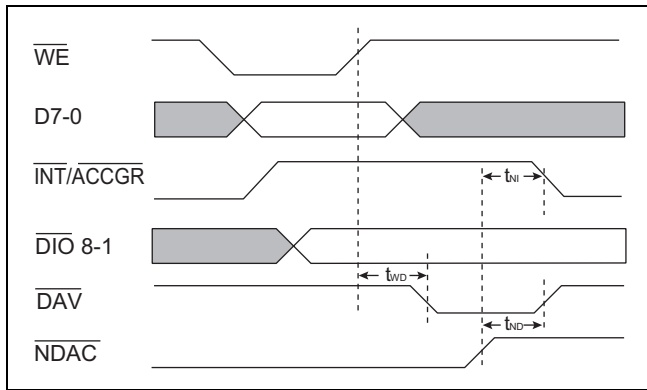

Figure 9. Source Handshake Timing

Acceptor Handshake

Parameter	Symbol	Limits (ns)		Test Condition
		Min	Max	
DAV↓ to NDAC↑	$t_{DD}$		35+3T	
DAV↑ to NDAC↓	$t_{DF}$		25	
DAV↓ to INT↓ or ACCRQ↓	$t_{DI}$		50+2T	INT(DIIE Bit=1), ACCGR (DMAI Bit=1)
DAV↓ to NRFD↓	$t_{DR}$		20	
DBIN↑ to NRFD↑	$t_{NR}$		35	Read of DIR, not in Holdoff state

Note: T = one clock period

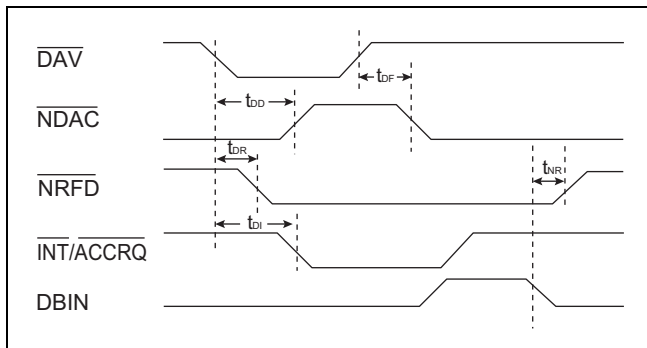

Figure 10. Acceptor Handshake Timing

Response to ATN

Parameter	Symbol	Limits (ns)		Test Condition
		Min	Max	
ATN↑ to NRFD↓	$t_{AF}$		35	Acceptor handshake holdoff
ATN↓ to NDAC↓	$t_{AN}$		35	AIDS → ANRS
ATN↓ to TE↓	$t_{AT}$		30	TACS → TADS

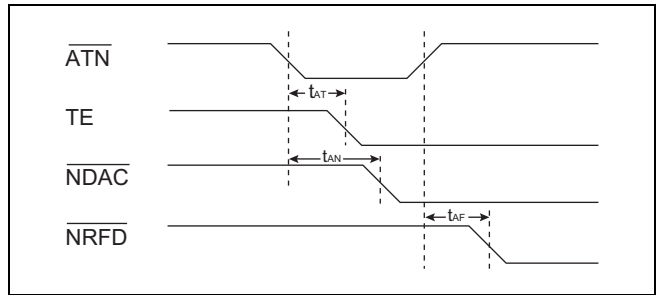

Figure 11. ATN Response Timing

Parallel Poll

Parameter	Symbol	Limits (ns)		Test Condition
		Min	Max	
EOI↓ to DIO↓ valid	$t_{ED}$		90	PPSS → PPAS
EOI↓ to TE↑	$t_{ET}$		30	PPSS → PPAS
EOI↑ to TE↓	$t_{TE}$		30	PPAS → PPSS

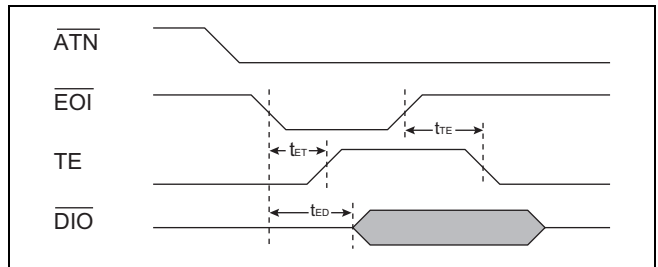

Figure 12. Parallel Poll Response Timing



# IEEE 488.2 Controller Chip

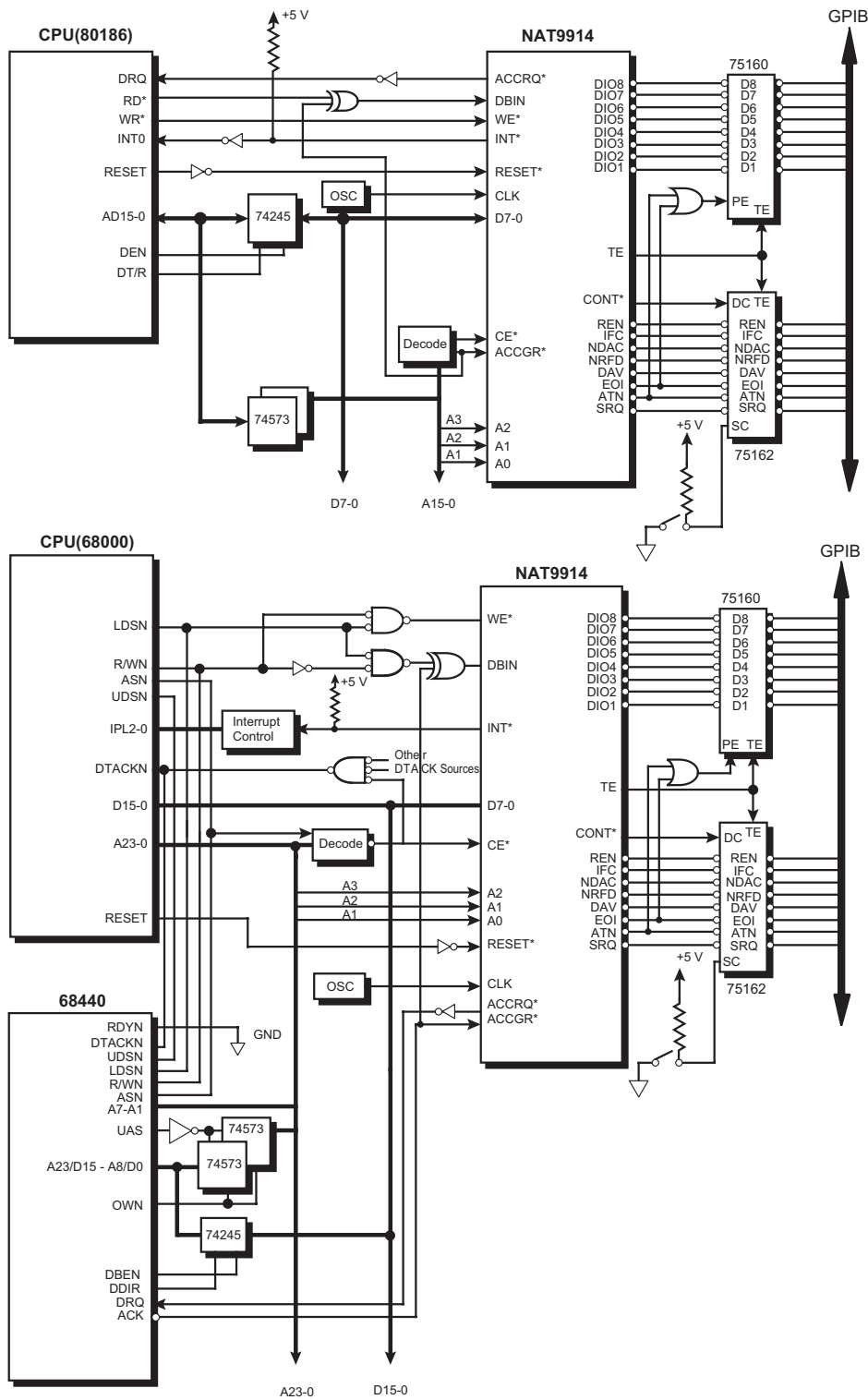

Figure 13. Typical CPU Systems with NAT9914



## IEEE 488.2 Controller Chip

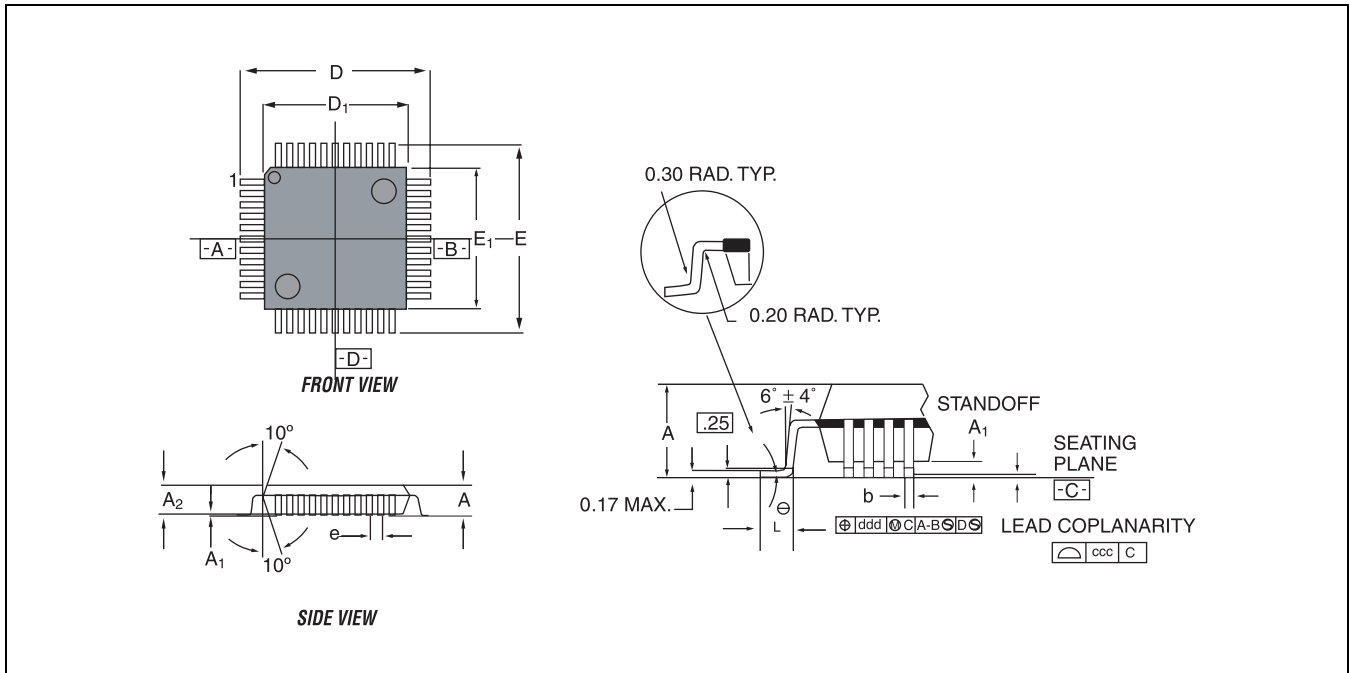

Figure 16. Mechanical 44-Pin QFP

Dimensions	Tolerance	Value (in mm)
A	max.	2.35
$A_1$	—	0.25 max.
$A_2$	+ 0.10/-0.05	2.00
D	$\pm 0.25$	17.20
$D_1$	$\pm 0.10$	14.00
E	$\pm 0.25$	17.20
$E_1$	$\pm 0.10$	14.00
L	+ 0.15/- 0.10	0.88
e	basic	1.00
b	$\pm 0.05$	0.35
$\theta$	—	0 to $7^\circ$
ddd	—	0.20 nom.
ccc	max.	0.10

# NI Services and Support



NI has the services and support to meet your needs around the globe and through the application life cycle – from planning and development through deployment and ongoing maintenance. We offer services and service levels to meet customer requirements in research, design, validation, and manufacturing. Visit [ni.com/services](http://ni.com/services).

## Training and Certification

NI training is the fastest, most certain route to productivity with our products. NI training can shorten your learning curve, save development time, and reduce maintenance costs over the application life cycle. We schedule instructor-led courses in cities worldwide, or we can hold a course at your facility. We also offer a professional certification program that identifies individuals who have high levels of skill and knowledge on using NI products. Visit [ni.com/training](http://ni.com/training).

## Professional Services

Our Professional Services Team is comprised of NI applications engineers, NI Consulting Services, and a worldwide National Instruments Alliance Partner program of more than 600 independent consultants and integrators.



Services range from start-up assistance to turnkey system integration. Visit [ni.com/alliance](http://ni.com/alliance).

## OEM Support

We offer design-in consulting and product integration assistance if you want to use our products for OEM applications. For information about special pricing and services for OEM customers, visit [ni.com/oem](http://ni.com/oem).

## Local Sales and Technical Support

In offices worldwide, our staff is local to the country, giving you access to engineers who speak your language. NI delivers industry-leading technical support through online knowledge bases, our applications engineers, and access to 14,000 measurement and automation professionals within NI Developer Exchange forums. Find immediate answers to your questions at [ni.com/support](http://ni.com/support).

We also offer service programs that provide automatic upgrades to your application development environment and higher levels of technical support. Visit [ni.com/ssp](http://ni.com/ssp).

## Hardware Services

### NI Factory Installation Services

NI Factory Installation Services (FIS) is the fastest and easiest way to use your PXI or PXI/SCXI combination systems right out of the box. Trained NI technicians install the software and hardware and configure the system to your specifications. NI extends the standard warranty by one year on hardware components (controllers, chassis, modules) purchased with FIS. To use FIS, simply configure your system online with [ni.com/pxiadvisor](http://ni.com/pxiadvisor).

### Calibration Services

NI recognizes the need to maintain properly calibrated devices for high-accuracy measurements. We provide manual calibration procedures, services to recalibrate your products, and automated calibration software specifically designed for use by metrology laboratories. Visit [ni.com/calibration](http://ni.com/calibration).

### Repair and Extended Warranty

NI provides complete repair services for our products. Express repair and advance replacement services are also available. We offer extended warranties to help you meet project life-cycle requirements. Visit [ni.com/services](http://ni.com/services).