

作成承認印

配布許可印



AF-S VR Zoom-Nikkor ED 70-200mm f/2.8G IF

REPAIR MANUAL

Nikon | NIKON CORPORATION
Tokyo, Japan

Copyright © 2003 by Nikon Corporation.
All Rights Reserved.

SPECIFICATIONS

Type of lens	G-type AF Zoom- Nikkor lens having built-in CPU and Nikon bayonet mount
Focal length	70mm-200mm
Maximum aperture	f/2.8
Lens construction	21 elements in 15 groups (5 ED lens elements)
Picture angle	34°20'-12°20' (27°40'-9°50'with IX 240 system cameras, 22°50'-8°with Nikon Digital Camera D1/D1H/D1X/D100)
Focal length scale	70, 80, 105, 135, 200 mm
Distance information	Output to camera body
Zoom control	Manually via separate zoom ring
Focusing	Nikon Internal Focusing (IF) system (utilizing an internal Silent Wave Motor); manually via separate focus ring
Shooting distance scale	Graduated in meters and feet from 1.5m (5ft.) to infinity (∞)
Closest focus distance	1.5m at all zoom settings : Auto Focus 1.4m at all zoom settings : Manual Focus
Diaphragm	Fully automatic
Aperture range	f/2.8 to f/22
Exposure measurement	Via full-aperture method with cameras having CPU interface system
Attachment size	77mm (P = 0.75mm)
Dimensions	Approx. 87mm dia. ×215mm extension from the camera's lens mount flange
Weight	Approx. 1,470g

※BEFORE DISASSEMBLING, DISASSEMBLING AND ADJUSTING

① This lens loads the VR (Vibration Reduction) unit to perform the vibration reduction function.

To maintain the accuracy of the vibration reduction function, be sure to perform the VR adjustment by using the VR lens adjustment equipment (J15380) when removing the VR unit and Gyro PCB.

However, the VR adjustment is not necessary when disassembling the other parts.

② The optical axis between the 1st lens group and the VR unit has been adjusted so that the optical axis would not dislocate when the 1st group lens injects at zooming operation.

When replacing the 1st lens group or removing the VR unit, it is necessary to adjust the optical axis by using the auto collimator and the special tool.

At the service facilities where [VR lens adjustment equipment] and [Auto Collimator and Special Tool] are not set up, do not repair or disassemble the product applicable to the above.

DISASSEMBLING/ASSEMBLING/ADJUSTMENT

1. DISASSEMBLING

1st LENS GROUP



《Ref.》

#74 is fixed with the frosted black paint and B111 is with the Screw Lock.

If the solvent (e.g. ethanol, etc) is poured into the clearance between #74 and B111, it is easier to detach them.

G4 ~ G5 LENS

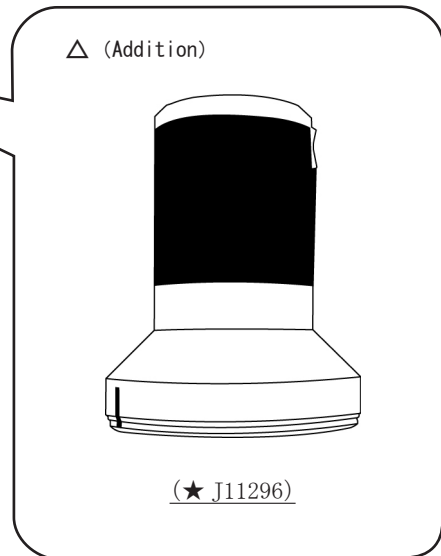
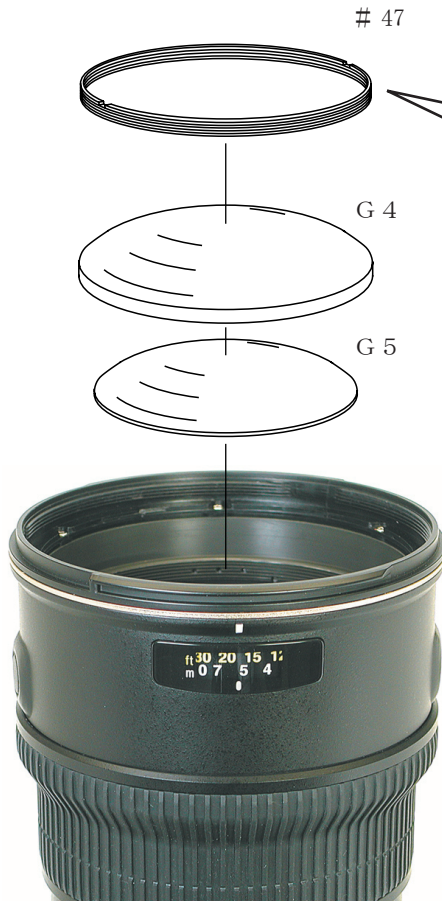

2nd LENS GROUP

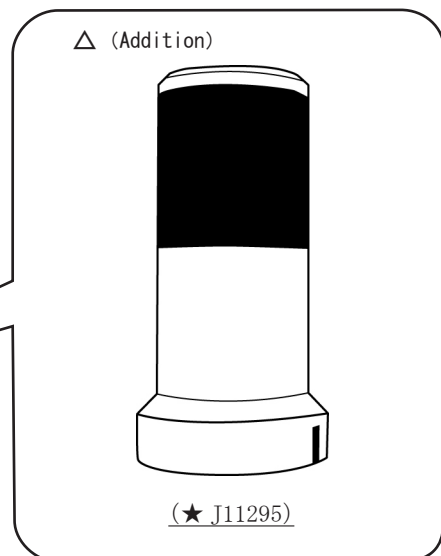

- The sheet #202 is attached with the both-sided adhesive tape.

Note: As there is a risk of deformation of the internal mechanism, when detaching the 2nd lens group, take it out where the zoom ring is positioned on the TELE side (200mm) rather than the WIDE one (80mm).



September. 20. 2007

TRIPOD RING

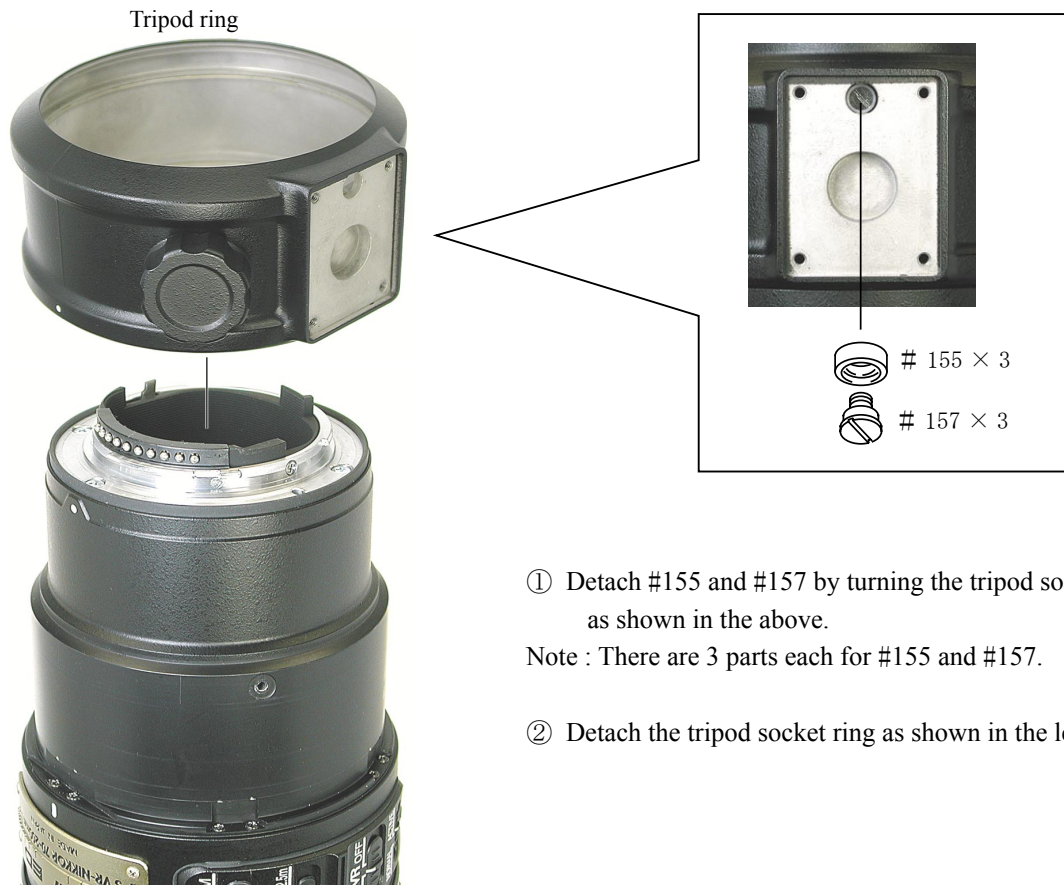
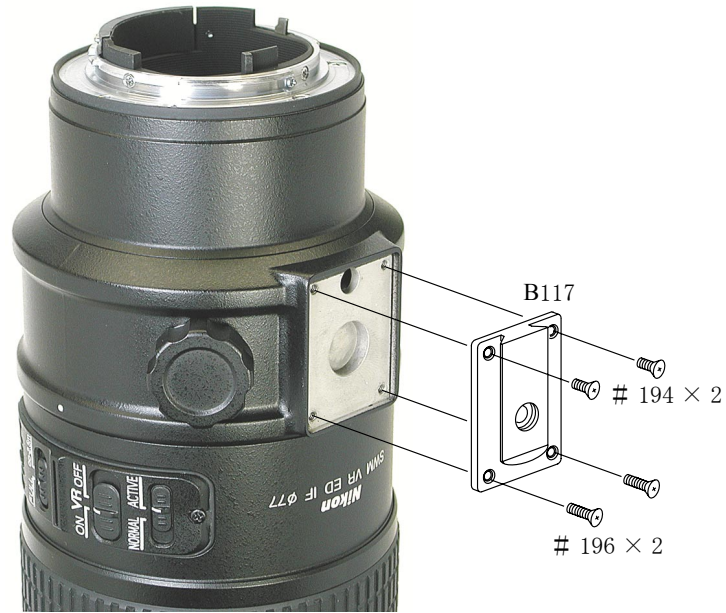

① Detach #155 and #157 by turning the tripod socket ring as shown in the above.

Note : There are 3 parts each for #155 and #157.

② Detach the tripod socket ring as shown in the left .

SELECTOR SWITCH UNIT



- If the selector switch B107 is lifted and removed, it is seen that the FPCs are connected to the connectors on the main PCB.
Disconnect the FPC that comes from the selector switch and the other 2 FPCs from the 3 connectors.

SEPARATION OF THE REAR GROUP

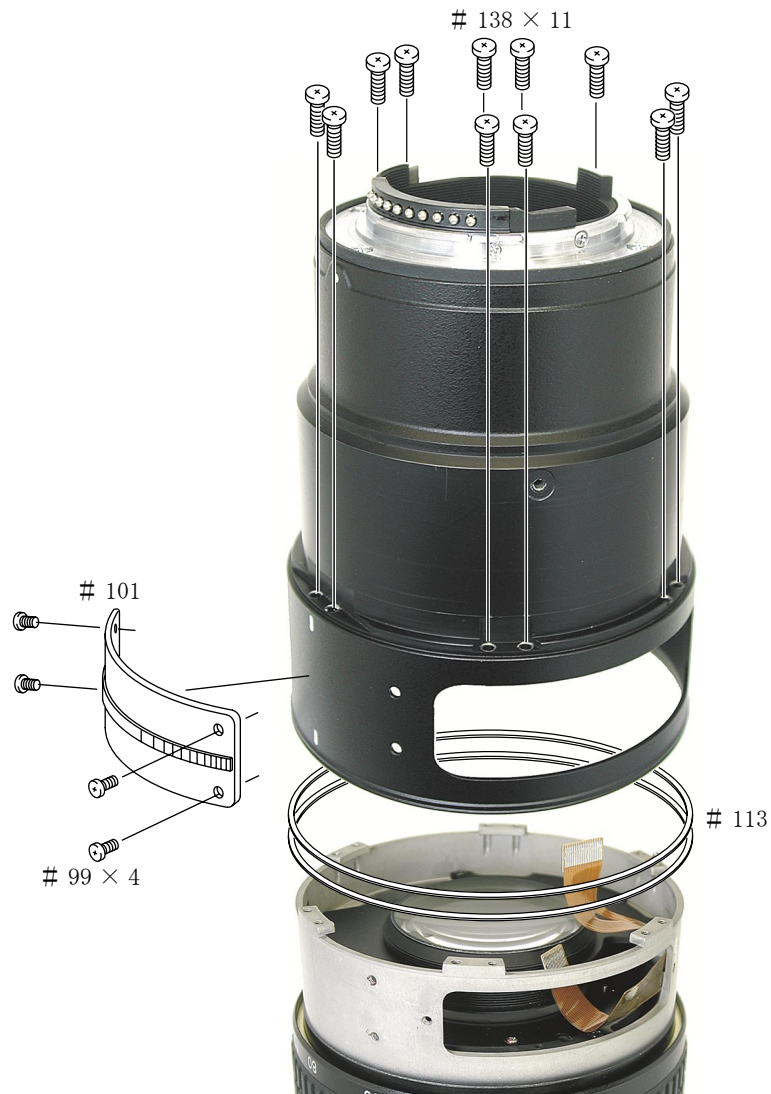

MAIN PCB

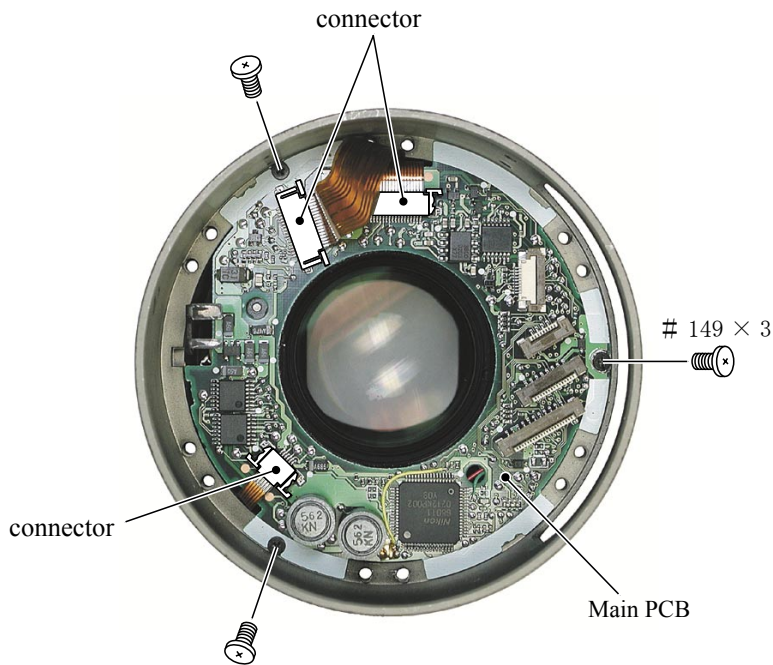

- ① Detach the FPCs from the 3 connectors.
- ② Remove the 3 screws #149 and detach the main PCB.

VR UNIT



6th LENS GROUP



REAR COVER RING, APERTURE LEVR UNIT

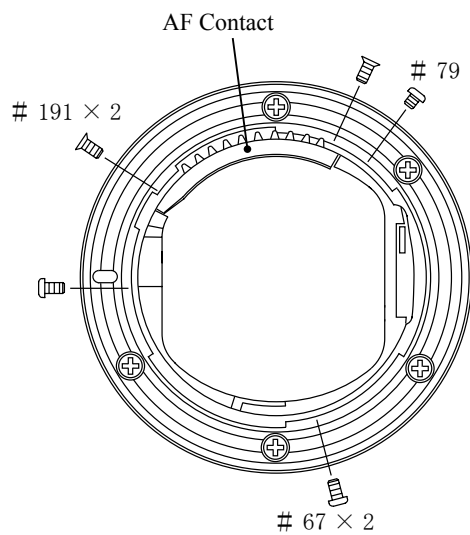

● By unscrewing the 2 screws #191, the AF contact part can be detached.

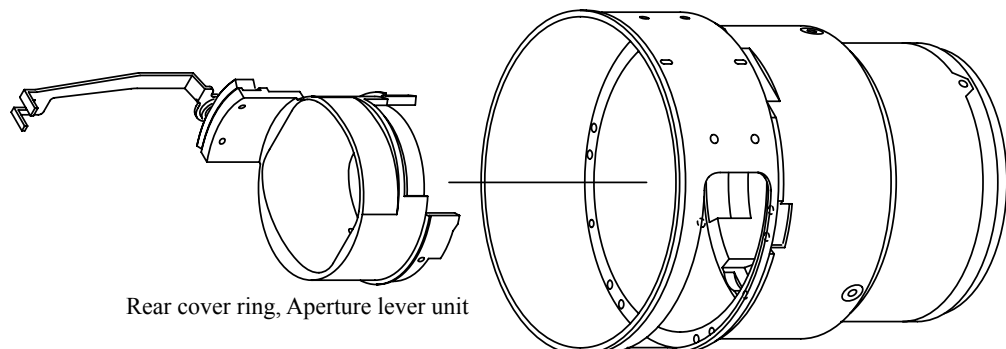

Rear cover ring, Aperture lever unit

4.th LENS GROUP

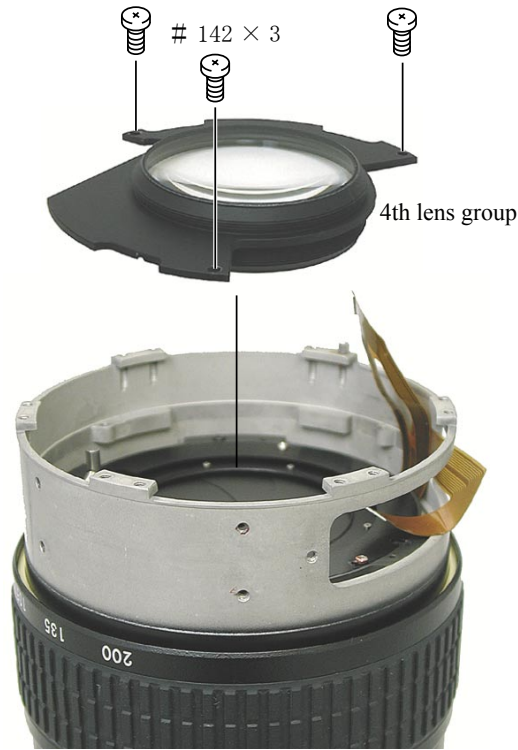

APERTURE BLADE UNIT

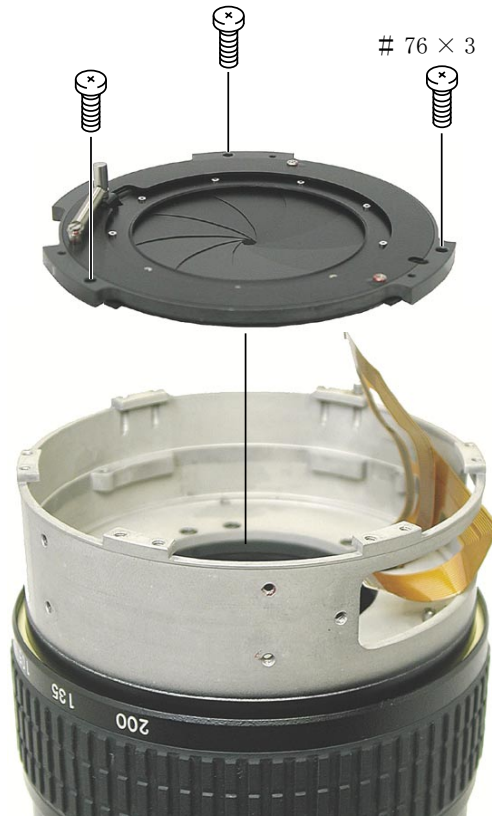

ZOOM RING

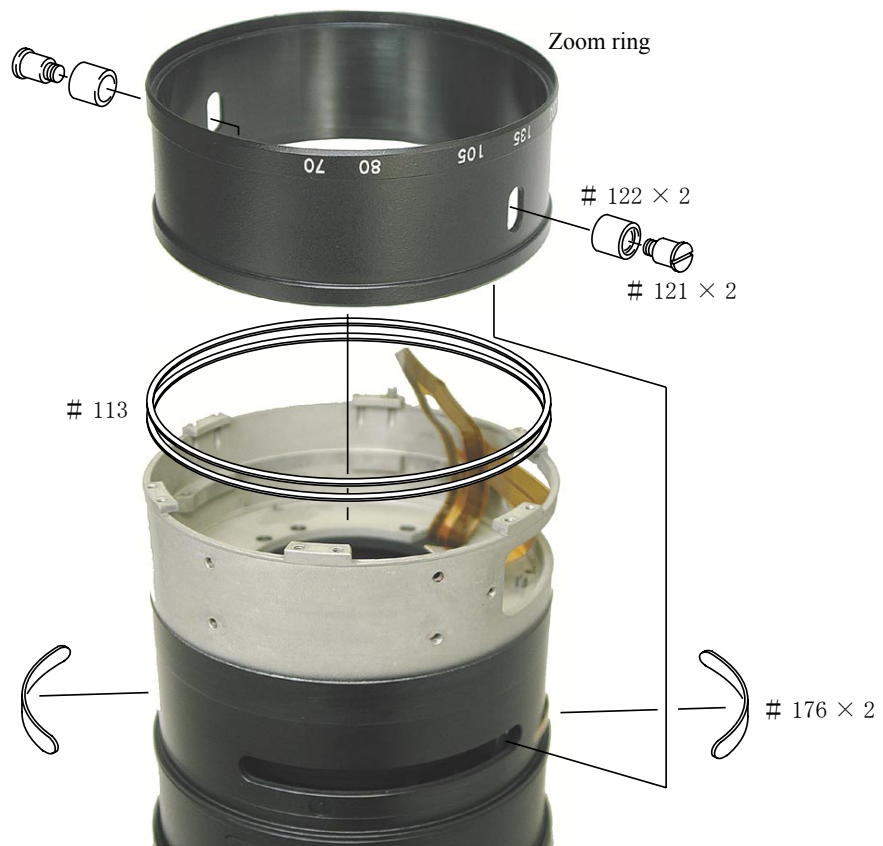
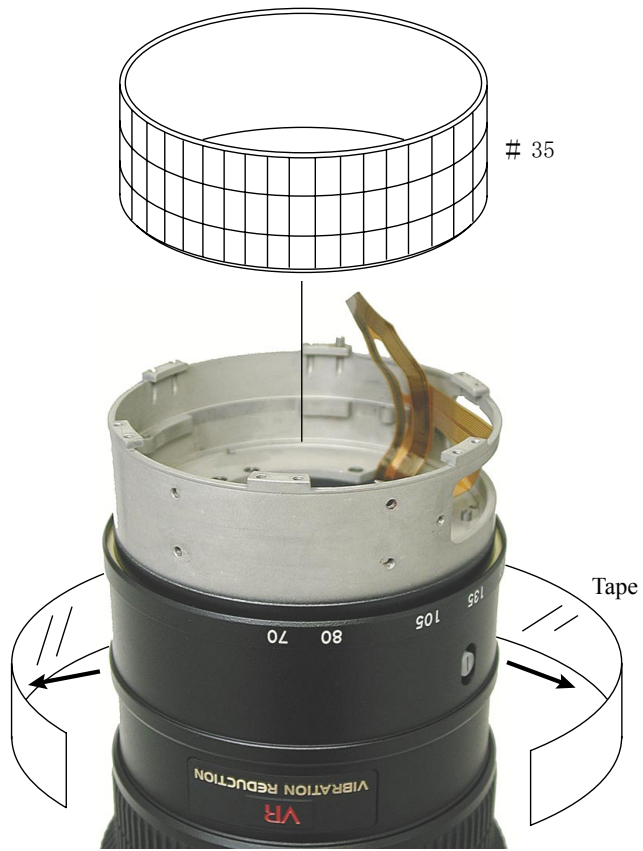

ZOOM FIXED RING, MF RING



ZOOM MIDDLE RING

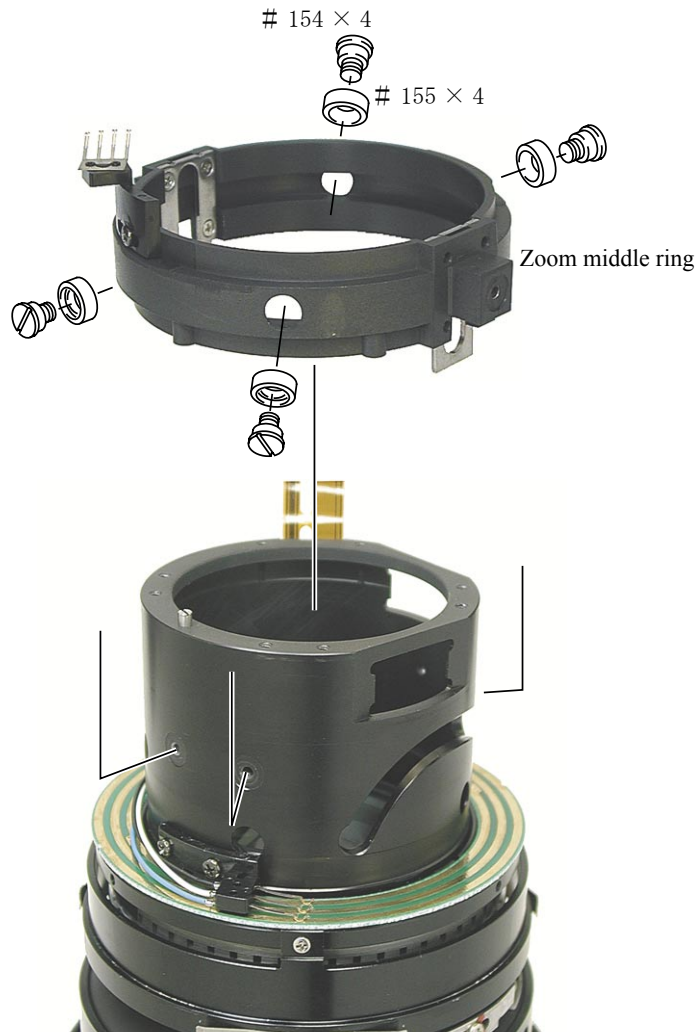
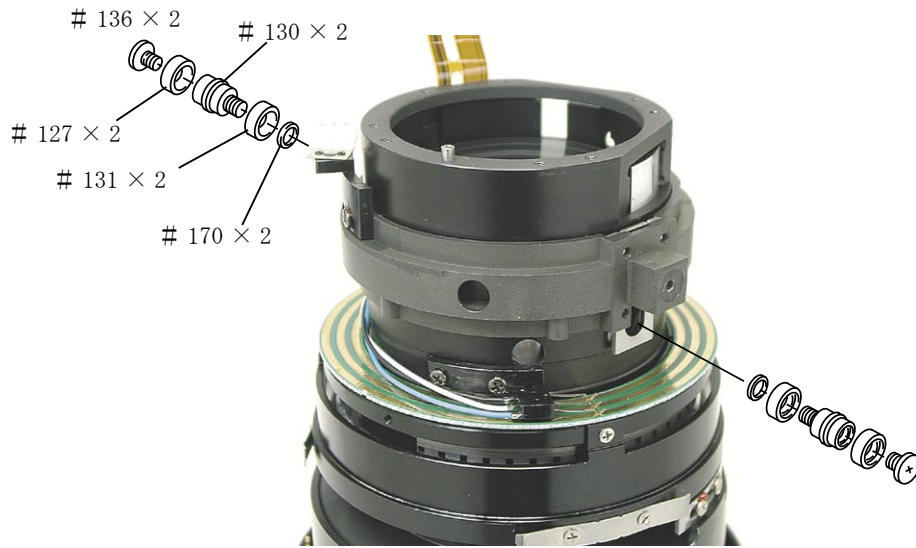

POWER BRUSH UNIT

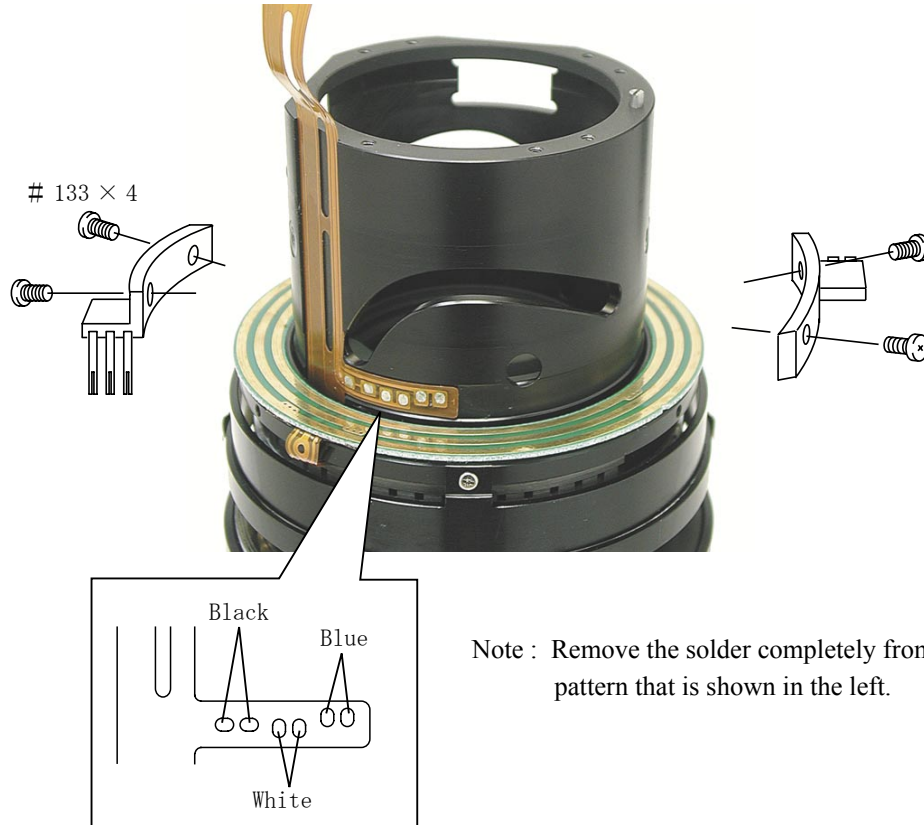

SWM UNIT



FOCUS LOCK RING UNIT



DISTANCE ENCODER BRUSH, FOCUS INDEX UNIT

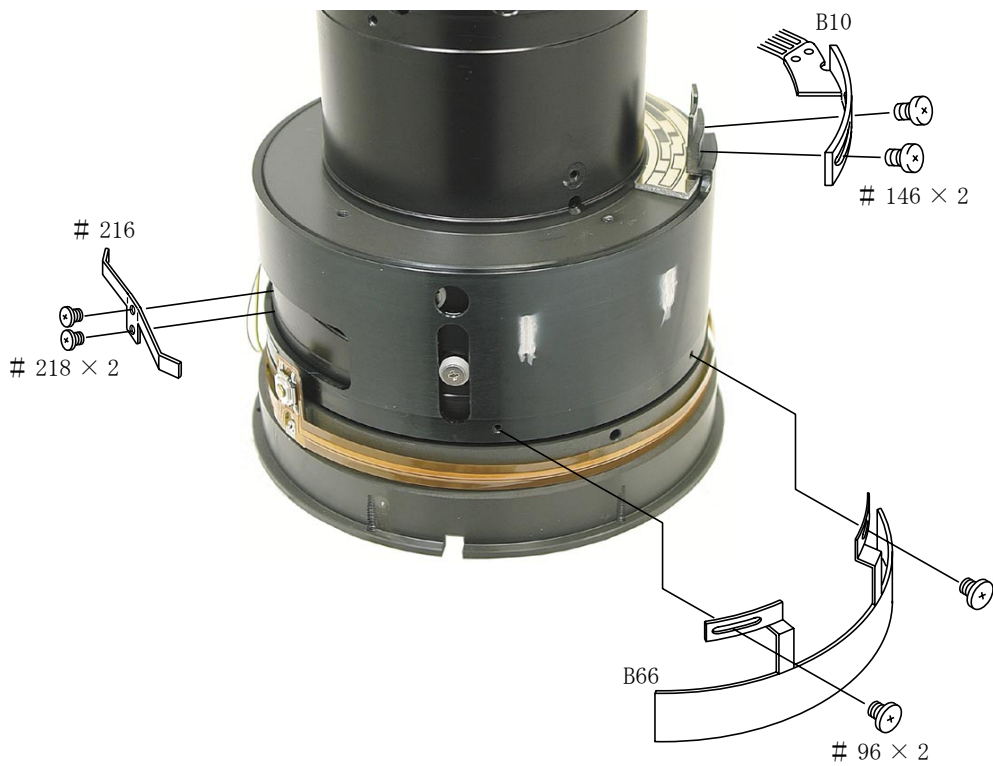

MR HEAD, BRUSH UNIT, AF-L FPC

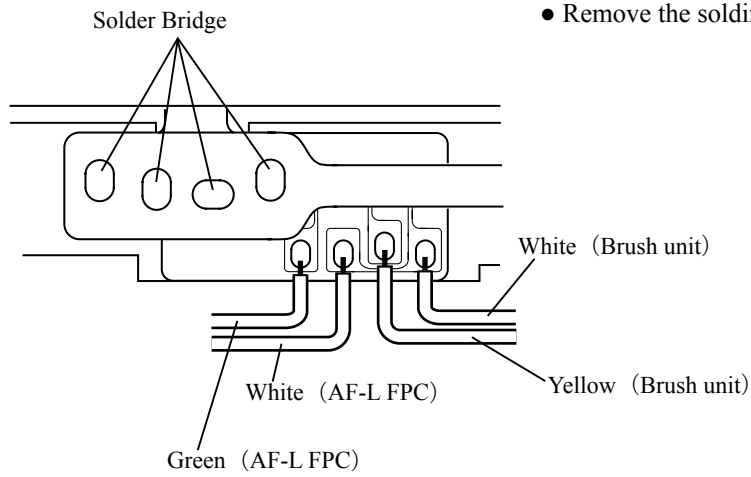

- Remove the soldering bridges and the solder for each wire.

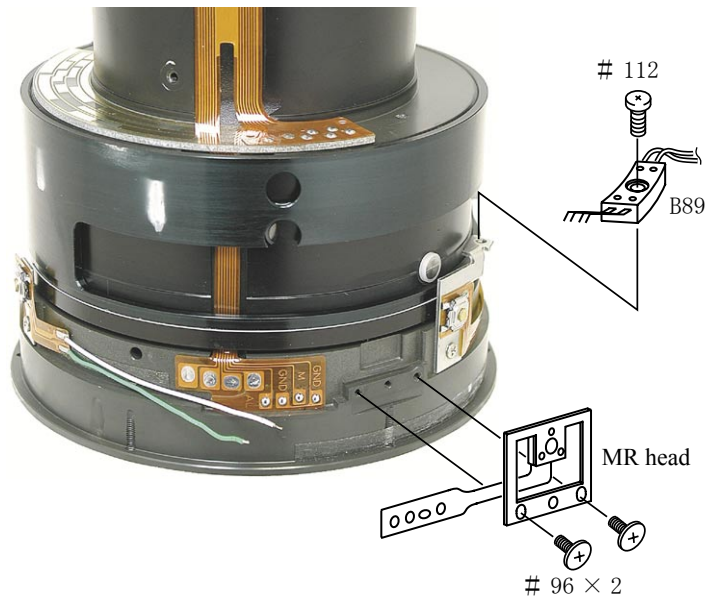

G4 ~ G5 LENS HOUSING



FOCUS MIDDLE RING





2. ASSEMBLING/ADJUSTMENT

RELAY FPC UNIT

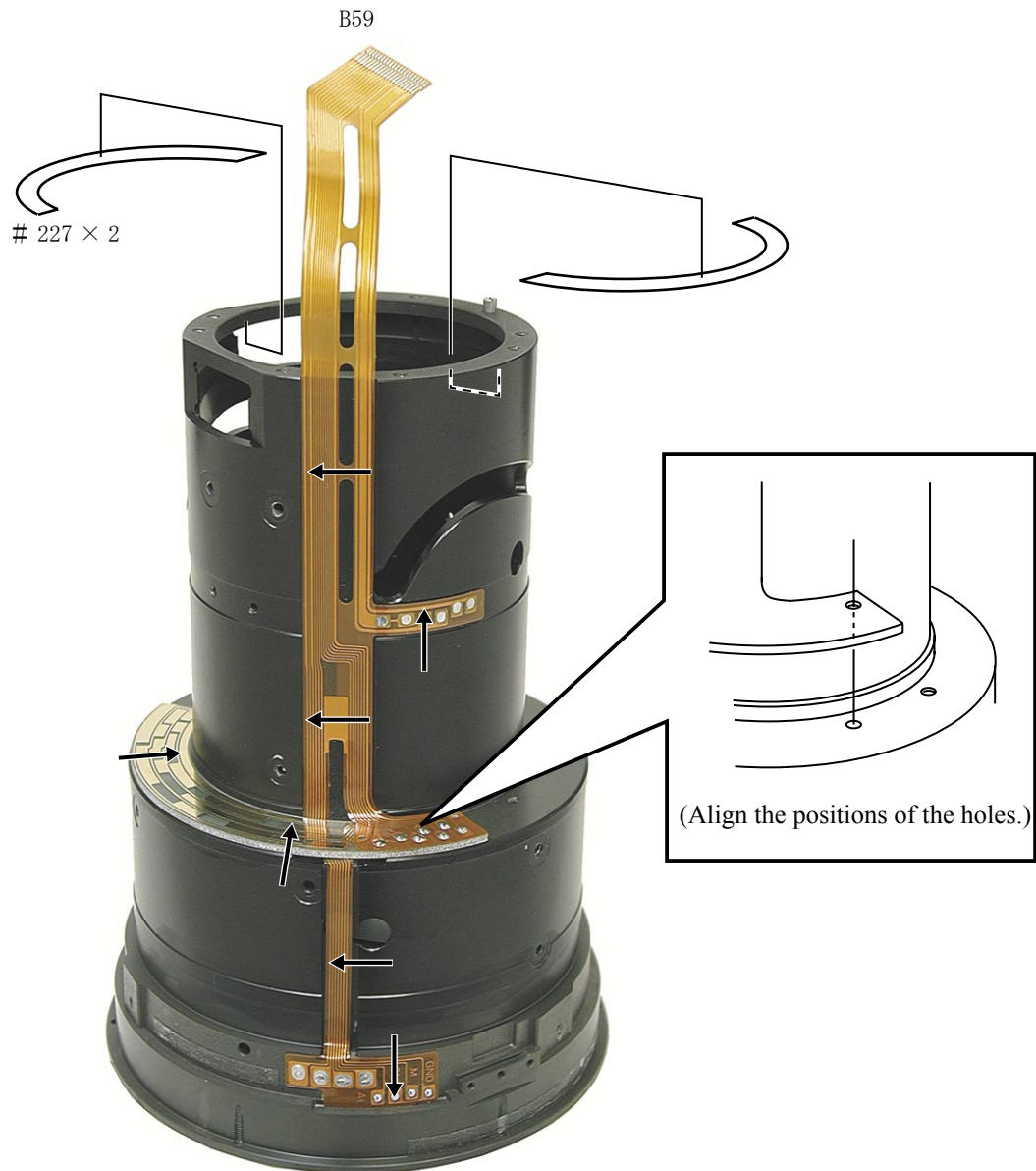

- As shown in the above, attach the B59 by moving towards the direction of arrow for each position.

FOCUS MIDDLE RING

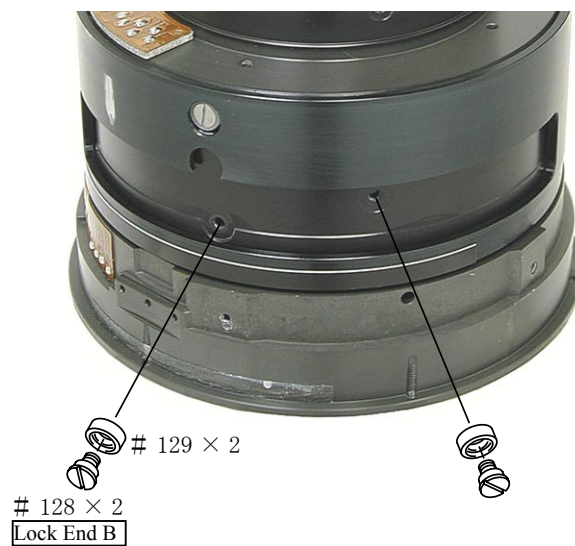

G4 ~ G5 LENS HOUSING



AF-L FPC

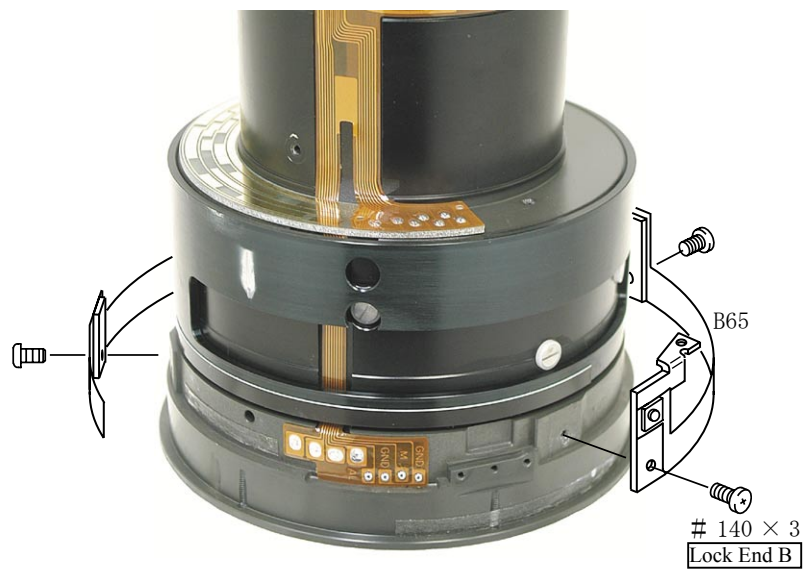

MR HEAD, BRUSH UNIT

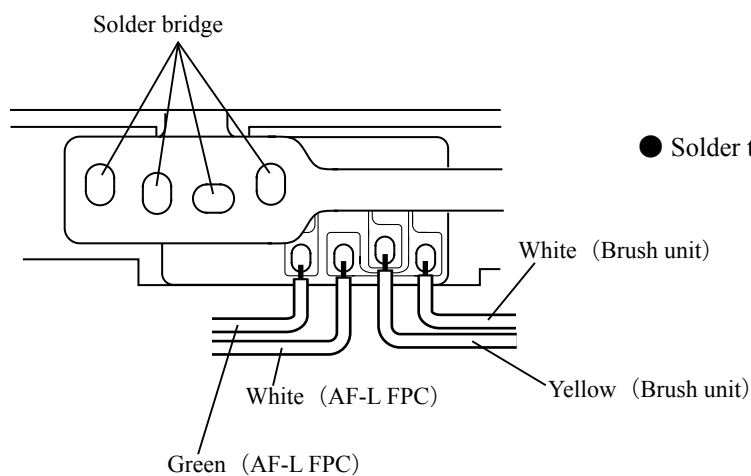
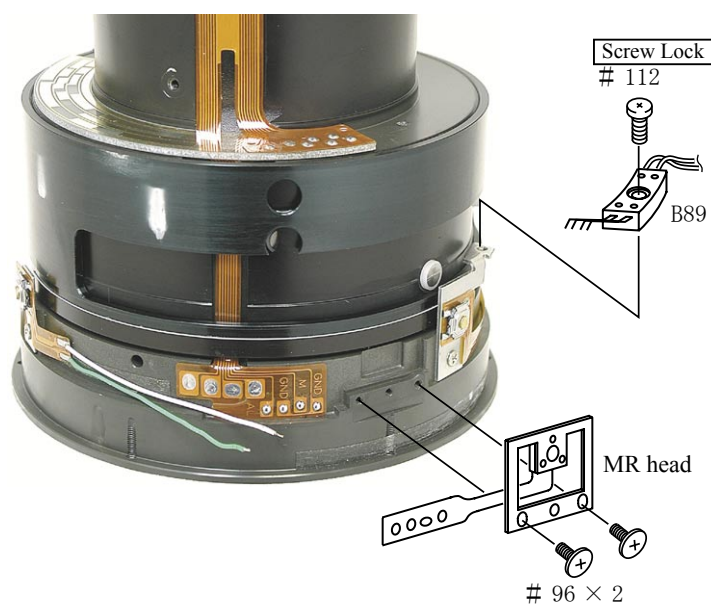

● Solder the soldering bridges and each wire.

INSPECTION AND ADJUSTMENT FOR THE WAVEFORM OUTPUT FROM MR ENCODER

● In case of disassembling or replacing the MR head, be sure to conduct adjustment.

1. Equipment and tools to be required

- Single output rated voltage power supply: 1 unit With 5.0V and 100mA, applicable to the self-made tool
- Oscilloscope: 1 unit
- Self-made tool: 1 unit

2. Prepare the measuring lens

- Solder the lead wire on the soldering bridge that attaches the MR head and connect with each measuring instrument.
(ref. the next page)

• Connection diagram

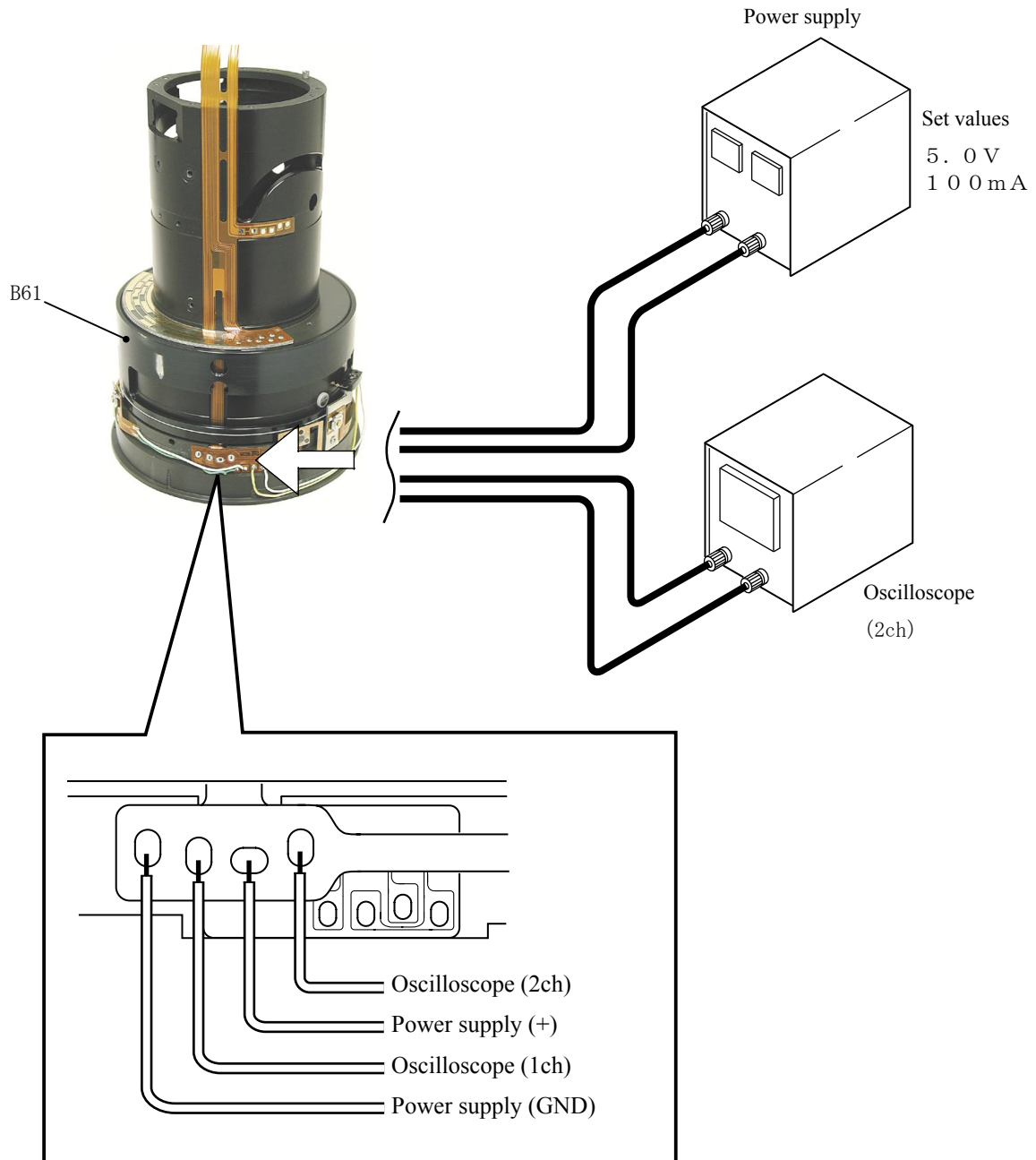

• How to conduct inspection and adjustment

- ① Make sure that the current and voltage of the connected rated voltage power supply are set values.
If they meet the set values, turn on the power.

- ② Set the oscilloscope and drive the focus ring by hand.

Note : Since the shape of waveform varies according to the driving speed of B61, particularly and properly set Time/Div.

- ③ In case of detecting any wider waveform noise, use the filter function.

How to set the filter function in the employment case of Yokogawa-manufactured DL1540

- 1 . Press the filter button.
- 2 . Select "Smooth" in the menu on the PC screen.

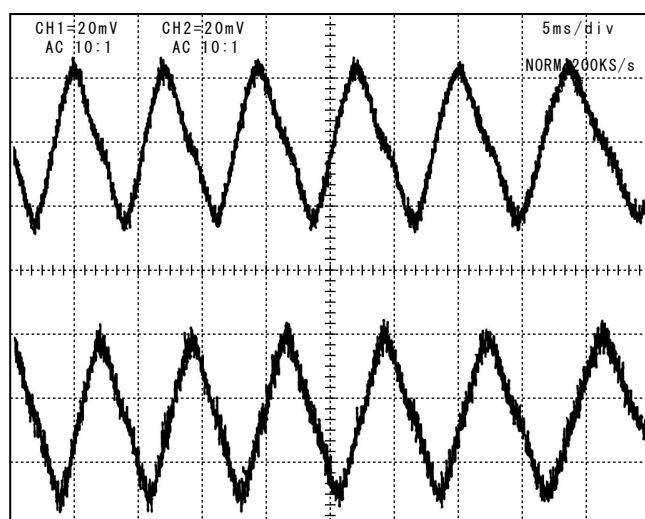

● Setting of oscilloscope

V/Div (CH1)	: 20 mV
V/Div (CH2)	: 20 mV
Coupling	: AC
Time/Div	: 5 m Sec
Trigger Mode	: NORMAL
Trigger Coupling	: AC
Trigger Source	: CH 1 ↗
Trigger Position	: + 4 div
Trigger Type	: EDGE
Trigger Level	: 0 V

Standard : The amplitude of every pulse/waveform should be 50mV or more.

Note : Check the waveform by letting the B61 to travel from the infinity-end position to the near distance end position and vice versa.

- ④ In the case of smaller amplitude, for adjustment, loosen the two screws #96 and then shift the MR head position as shown in the right figure.

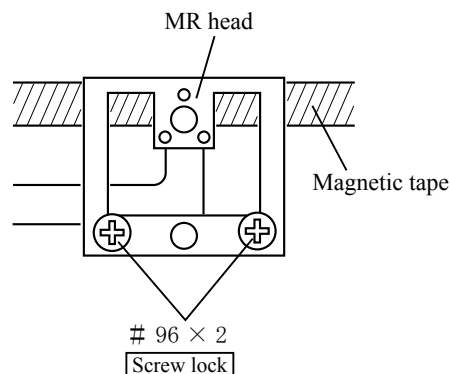

Note : During adjustment, prevent the magnetic tape and MR head from touching the magnetized driver bit, or the magnetic data may be damaged.

《Reference》

- In case the amplitude of either CH1 or CH2 seems smaller, one of the two screws #96 may be loosened. Then, check the screws. In case the screws are fully tightened, the MR head may be troubled. Then, be sure to replace the MR head unit B88 and adjust it again.

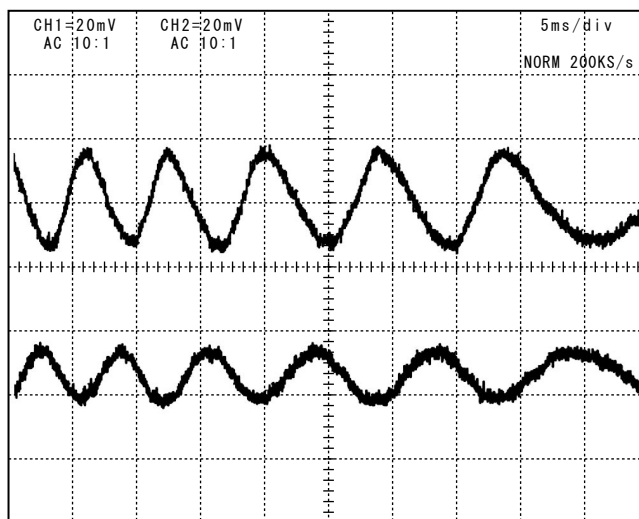

- In case there is a drop partially in the amplitude of vibration between the infinity and the closest, replace the magnetic tape (attached to B61) and readjust it because the data on magnetic tape may be damaged.

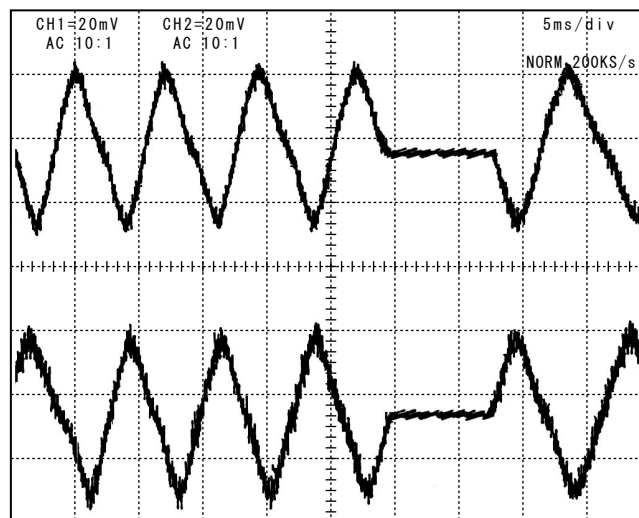

- ⑤ Turn the power supply OFF.

DISTANCE ENCODER BRUSH, FOCUS INDEX UNIT

Apply a quick-dry adhesive

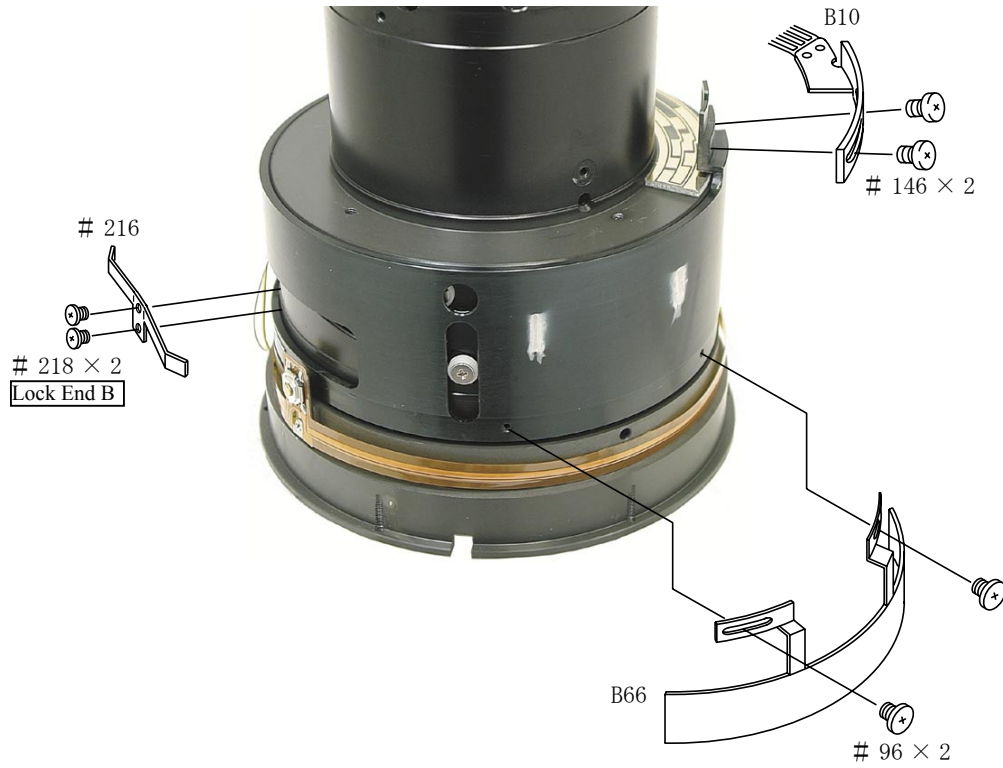

※ Screw temporarily the 2 screws each for #146 and #96.

3rd LENS GROUP



● Apply I-40 grease to the 2 parts of the B77 lead key, and to the 4 parts of the U groove and the entire periphery of #48.

SWM UNIT

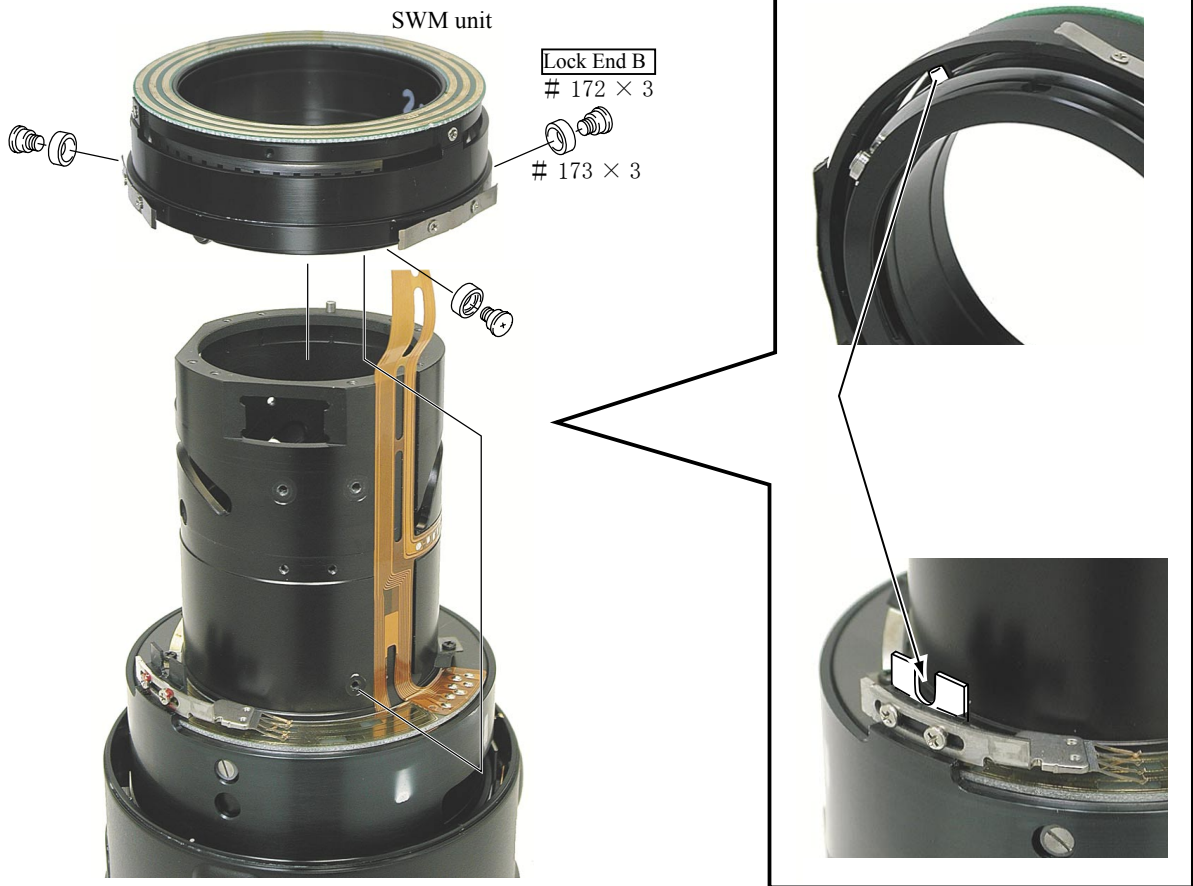

POWER BRUSH UNIT

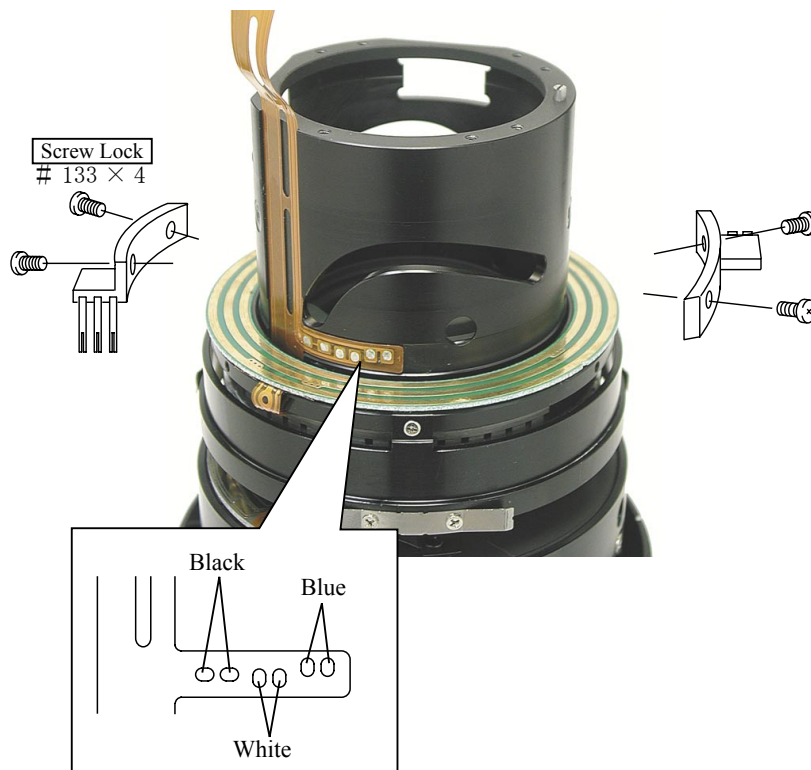

ZOOM MIDDLE RING

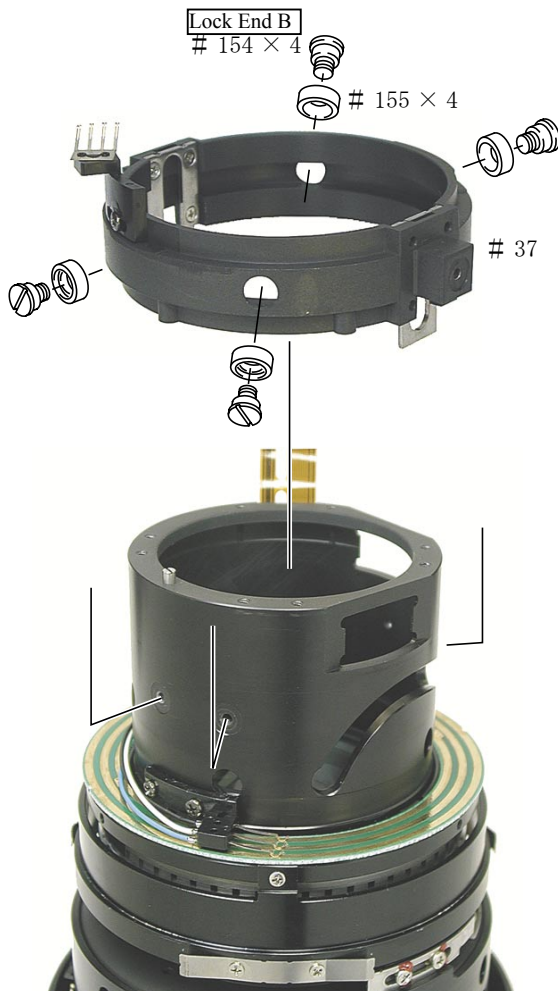
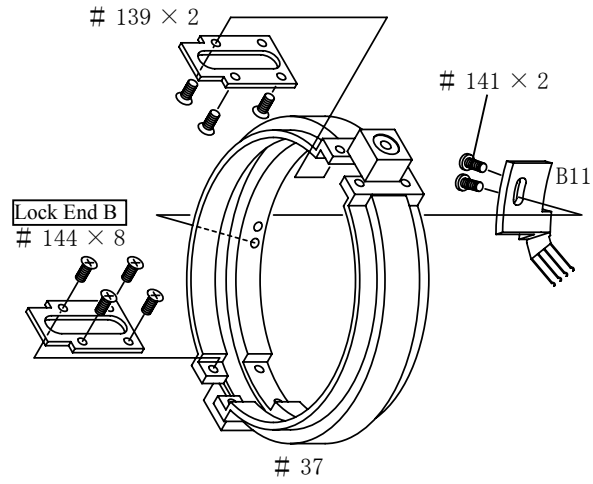

● Apply the G92KA on the inside of the zoom middle ring #37.

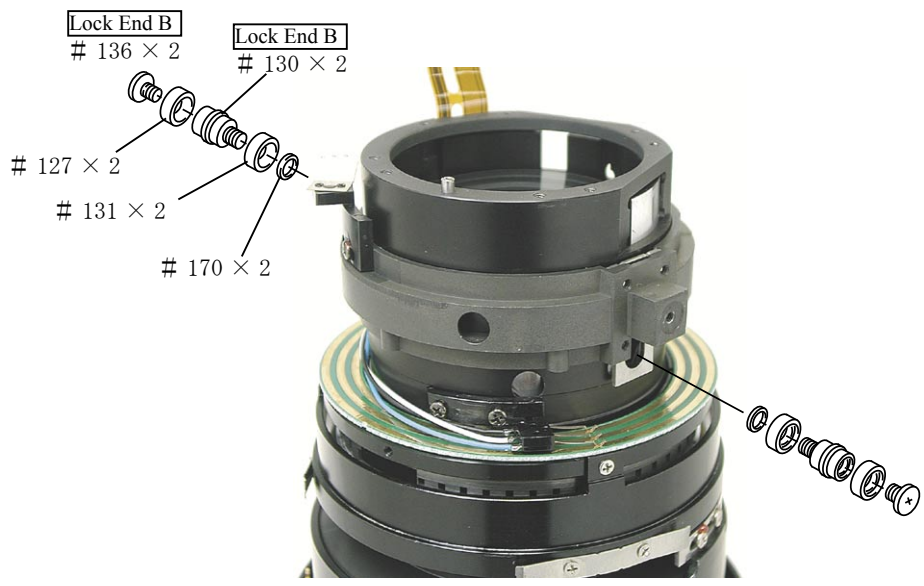

ADJUSTMENT OF ZOOM ENCODER BRUSH POSITION

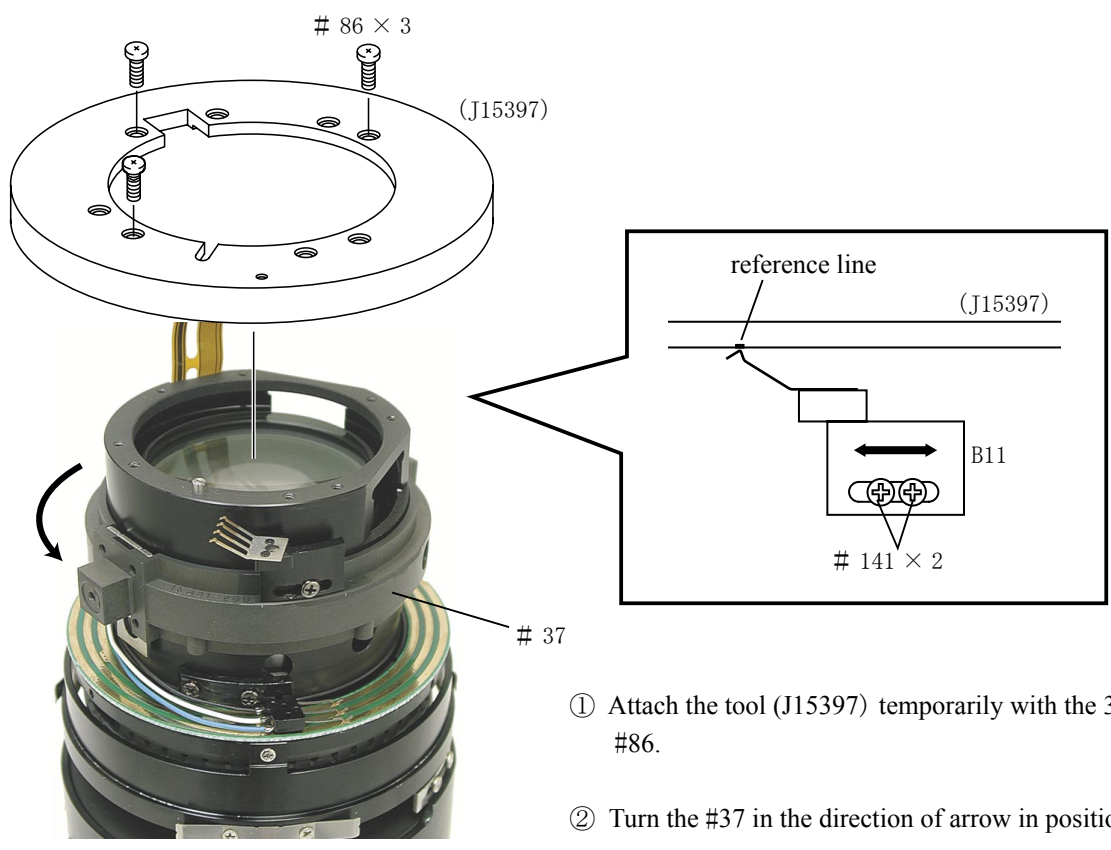

- ① Attach the tool (J15397) temporarily with the 3 screws #86.
- ② Turn the #37 in the direction of arrow in position.
- ③ As shown in the above, loosen the 2 screws #141 and move to adjust B11, for making contact between the reference line of the tool (J15397) and the edge of the brush. Then screw the #141.
- ④ Fix the 2 screws #141 with the Screw Lock.

ADJUSTMENT OF INFINITY POSITION

Set the size of G5-G6 lens



- ① Attach the focus-lock ring unit and the zoom fixed ring with 2 or 3 #137 and #86 screws. Work the screws temporarily.





② Attach the zoom ring temporarily.

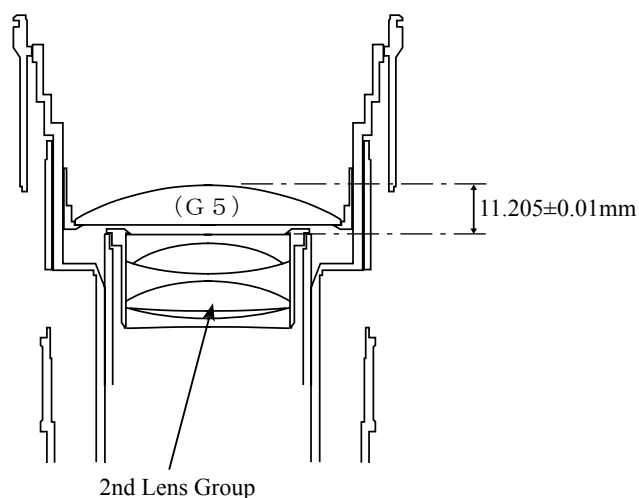

③ Attach the 2nd lens group unit to the lens body.

④ Set the lens body on the measurement stand.

⑤ Set the zoom ring to the W side. Then, put the pointer of digital micrometer on the edge of the 2nd lens group unit to reset the measured value (display).

⑥ Re-assemble the G5 lens and put the pointer of digital micrometer on the edge of the 2nd lens group unit.

⑦ Rotate the B61 and fix it in the position of 11.205 ± 0.01 mm of the measured value. The B61 is fixed by attaching the appropriate washer with temporarily screwing the #136 screw.

⑧ Remove the G5 lens and the 2nd lens group unit.



ADJUSTMENT OF ENCODER BRUSH POSITION

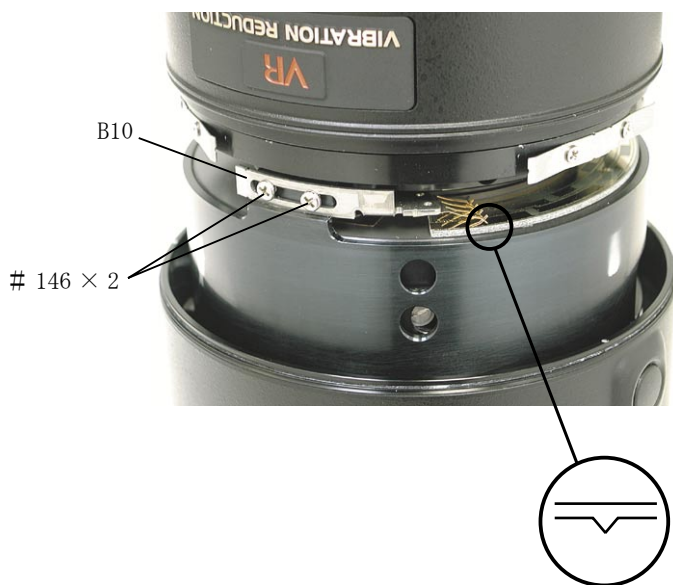

- ① Loosen the 2 screws #146 and move the distance encoder brush B10 to make the point of brush be positioned as shown in the left.
- ② Tighten the 2 screws #146 and fix them with the Screw Lock.

ADJUSTMENT OF FOCUS INDEX POSITION



- ① Detach the focus-lock ring unit.
- ② Loosen the 2 screws #96 and move the B66 to align the hole position of the #25 index side and the mark "∞" of B66.
- ③ Tighten the 2 screws #96 with the Screw Lock
- ④ Remove the zoom ring, the zoom fixing tube, and the washer used in Page L30.

GYRO PCB, ZOOM ENCODER BRUSH

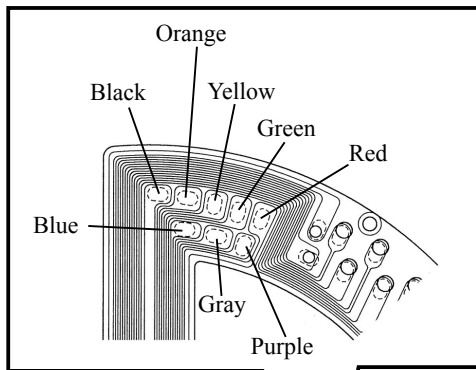

Note : Attach the zoom encoder brush B83 by aligning the side edge of the positioning hole and the side edge of B83 and moving in the direction of arrow.

《ref.》

It is easier to work by inserting the thin pin or drill, etc, into the positioning hole and attaching the B83.

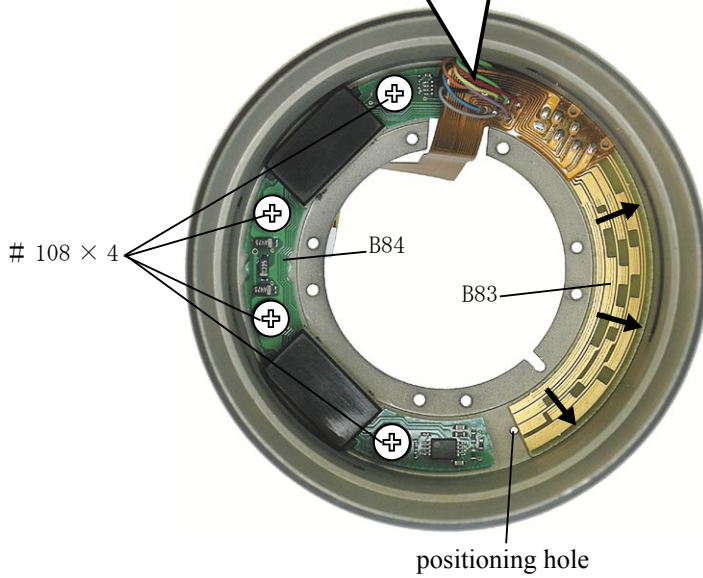

Lock End B
119 × 2

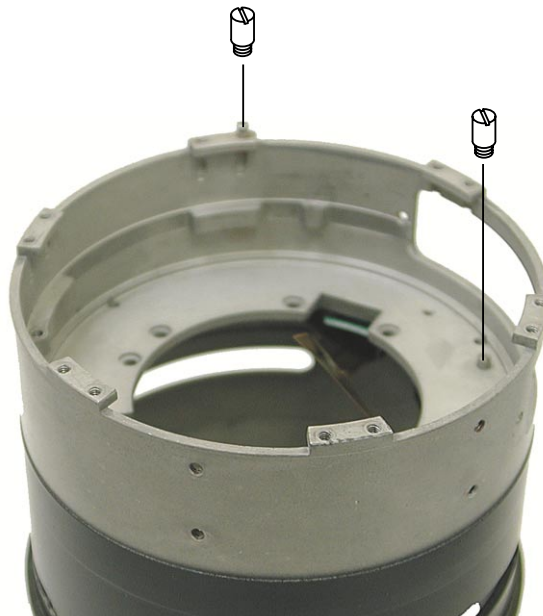

ZOOM FIXED RING, MF RING



ZOOM RING

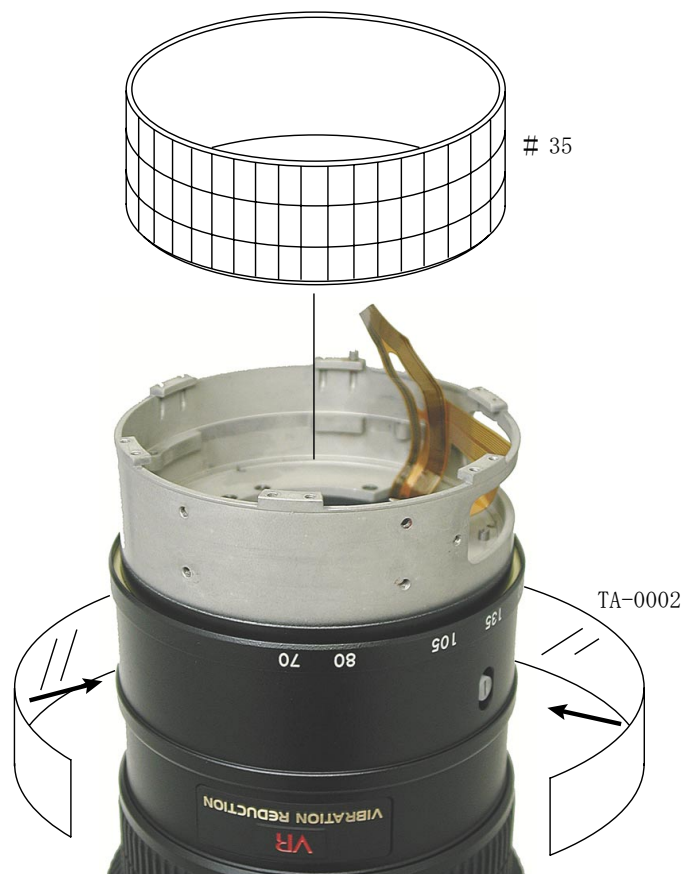
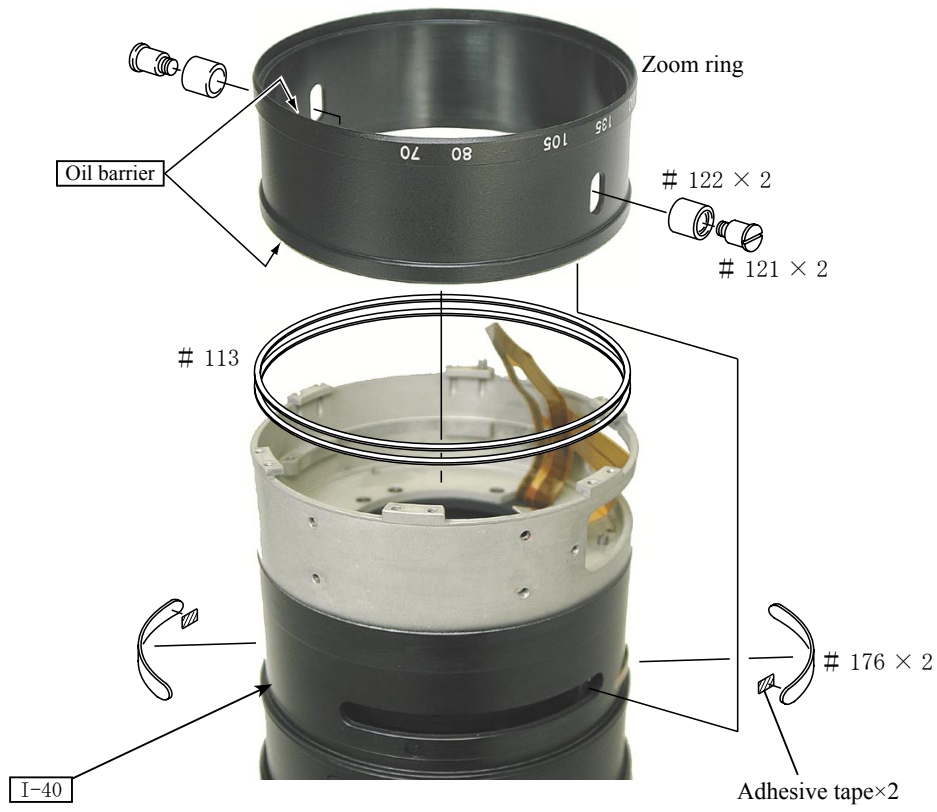

MEASURES TO PREVENT DUST FROM ENTERING

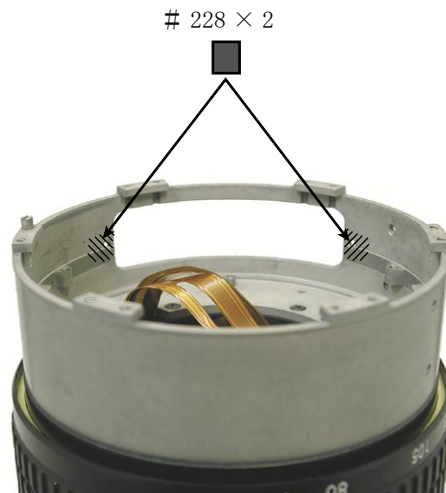

- Tape the #228 on each 6 hole shown in the left.

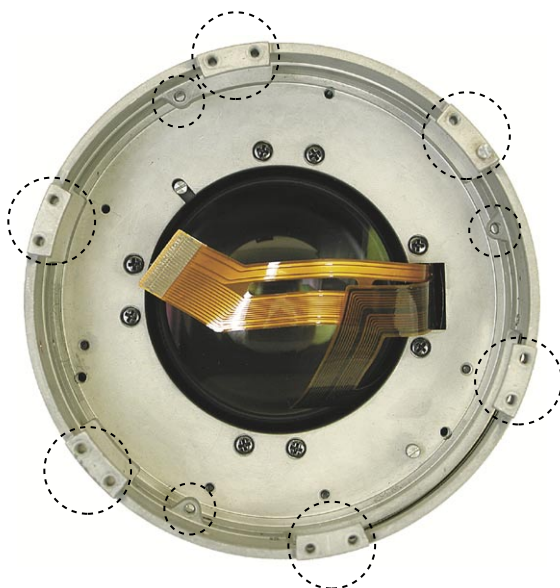

- Apply the adhesive C-8008B to the bottom of each screw hole as shown in the left to fill in the gap of the hole bottom.

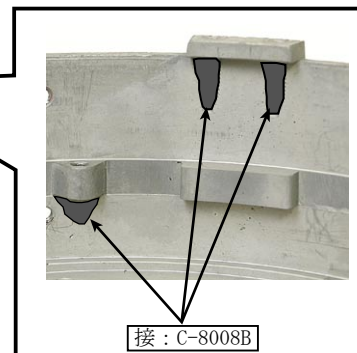

APERTURE BLADE UNIT

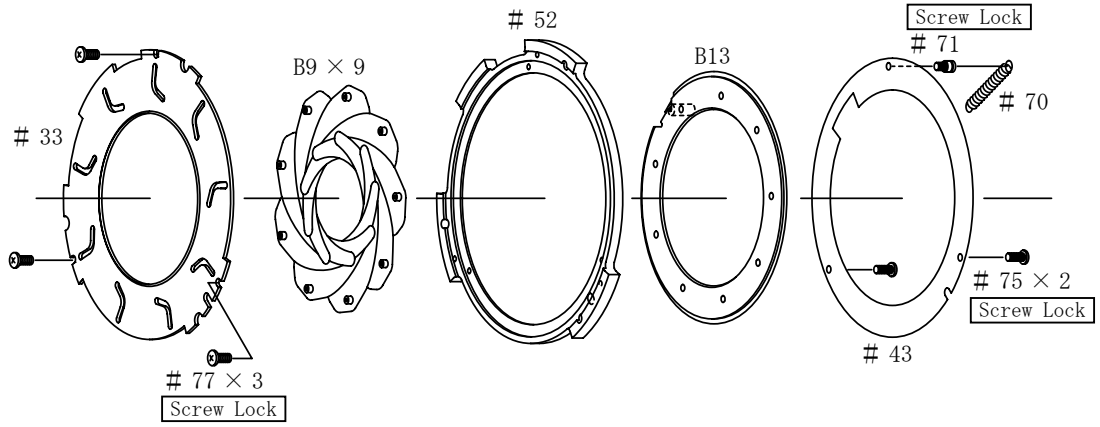

4th LENS GROUP

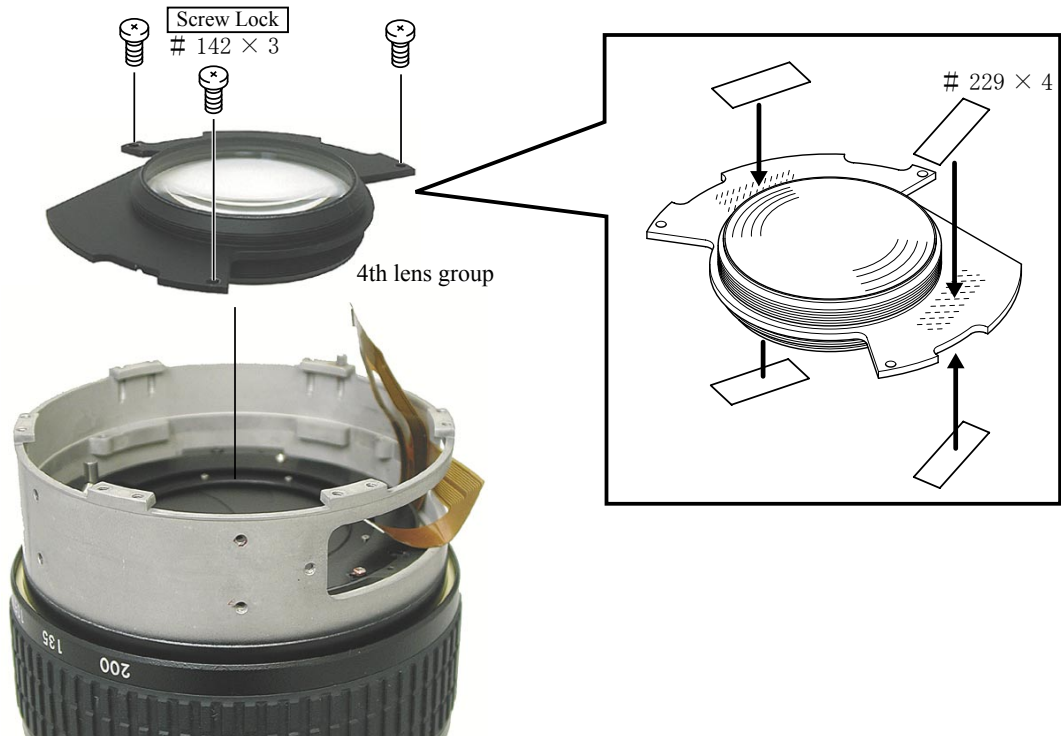

REAR COVER RING, APERTURE LEVER UNIT

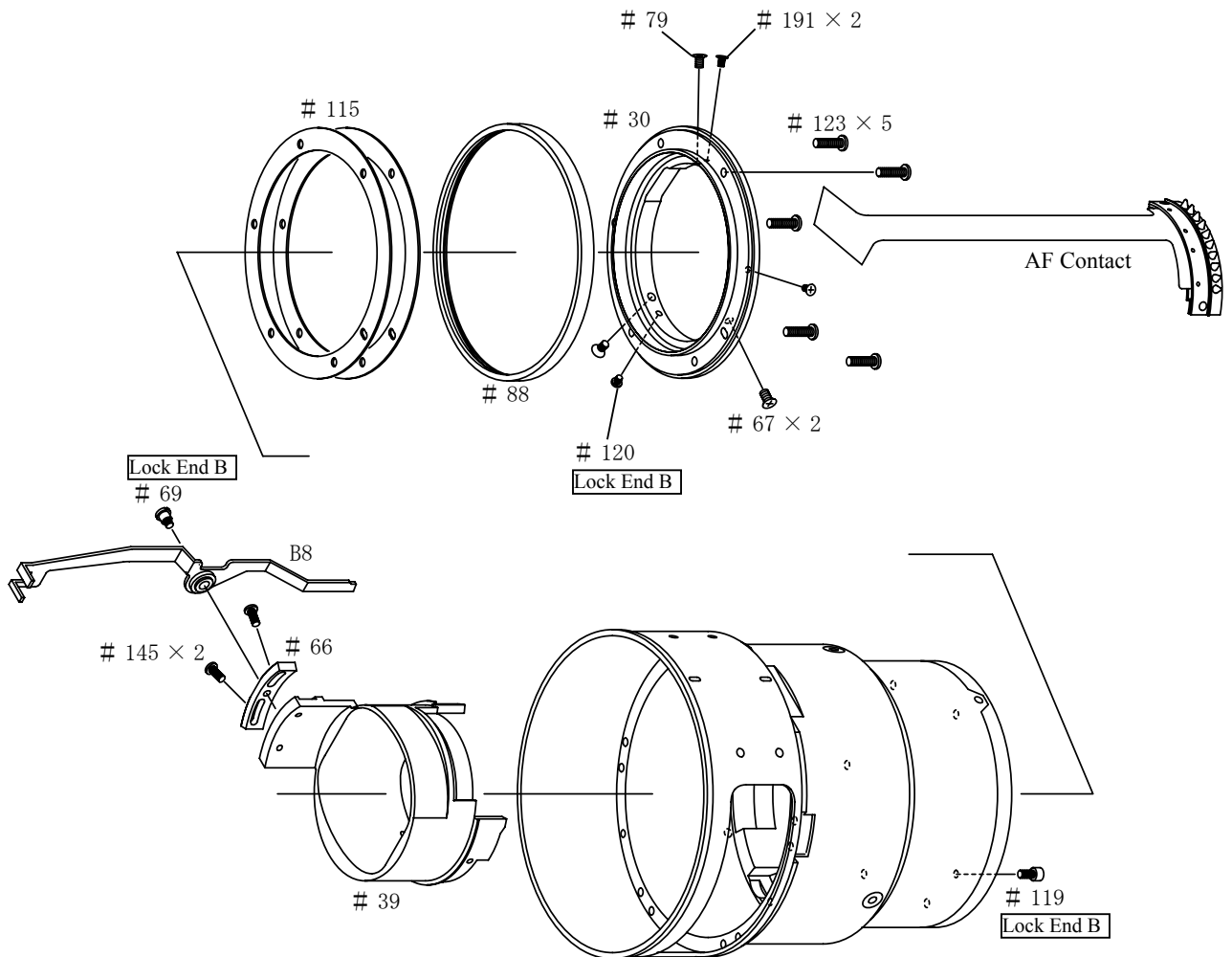

6th LENS GROUP



VR UNIT INCLINATION ADJUSTMENT

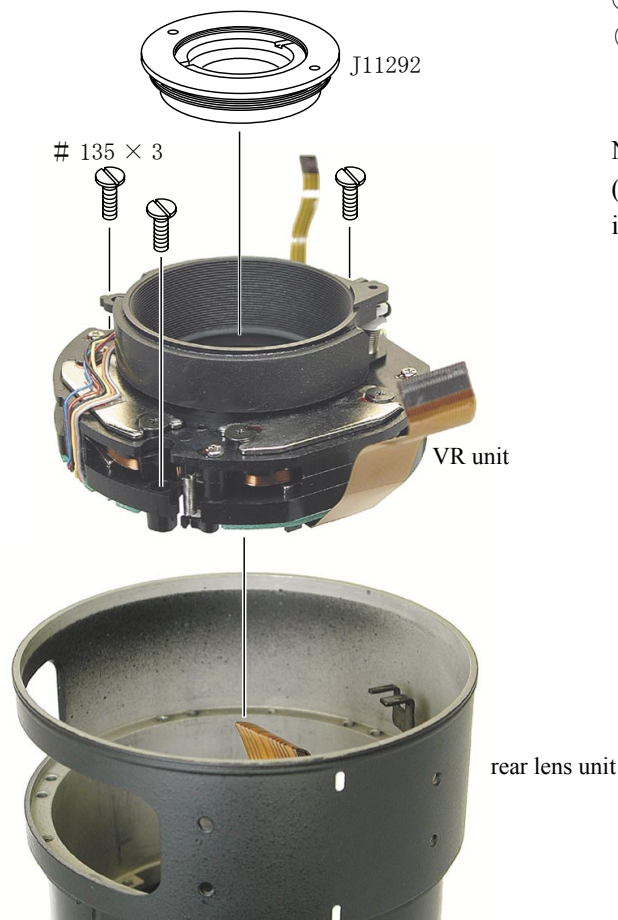

- ① Re-assemble the mirror tool (J11292) to the VR unit.
- ② Re-assemble the VR unit with the re-assembled mirror tool to the rear lens unit.

Note: Attach the mirror tool after inserting the pin (drill, etc.) into the 2 holes shown in the below to fix the inside of the unit.

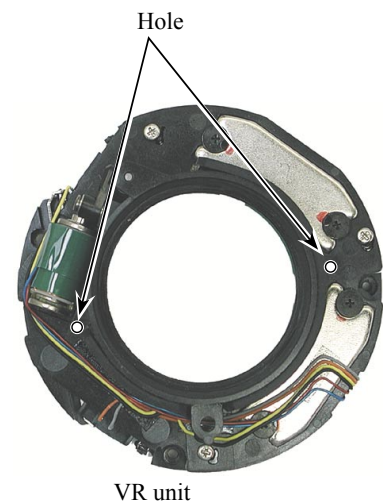

- ③ Mount the optical parallel (J15380-2) to the measuring stand (J18037) .
- ④ Fine adjust the position of the auto-collimeter to adjust the optical axis to the measuring stand.

《ref.》

The optical axis adjustment is possible by using the parallel glass or parallel mirror, etc, in place of J18037.

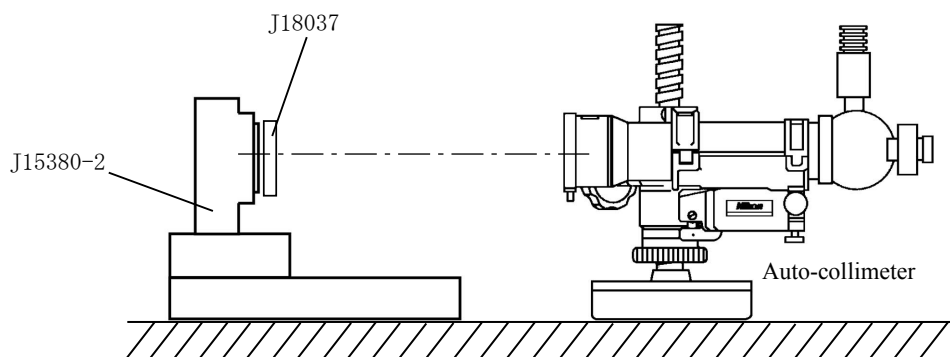

- ⑤ Mount the rear lens unit to the measuring stand (J15380-2) and put the parallel glass to the end of the rear lens unit.
- ※ The G1 lens for telephoto lens, e.g. AF-S300mm, etc, can be used as parallel glass.

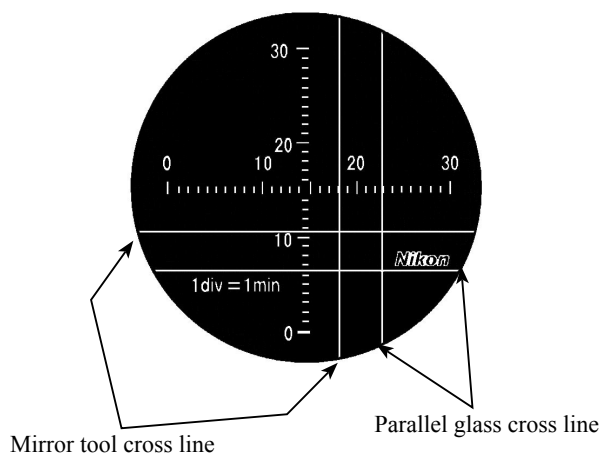
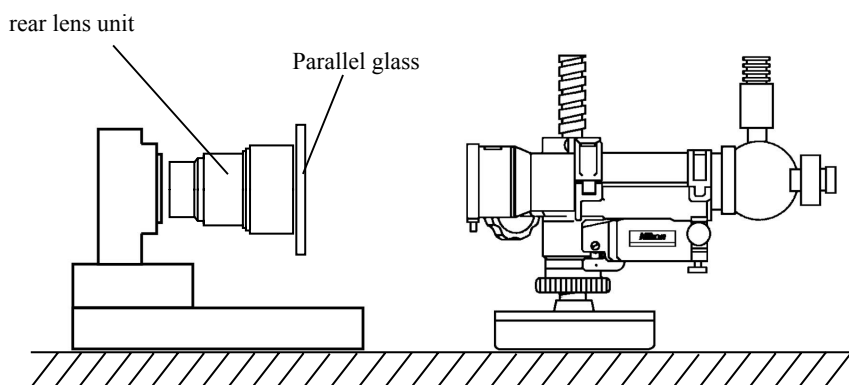

- ⑥ As shown in the left, measure a gap between the cross line of the mirror tool and that of the parallel glass.

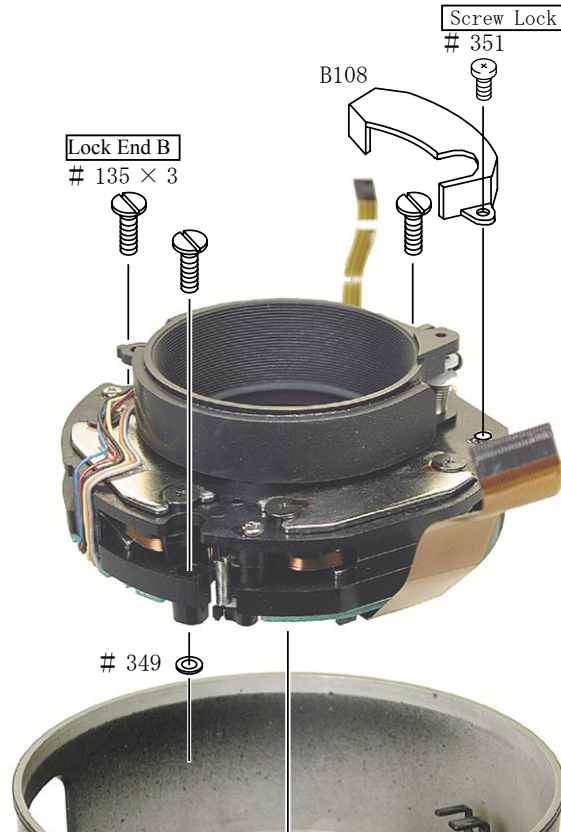

⑦ In case there is a gap of more than 2 min in the cross lines, correct the inclination by inserting the washer #349 as shown in the left.

⑧ After the adjustment, remove the mirror tool.

5th LENS GROUP



MAIN PCB

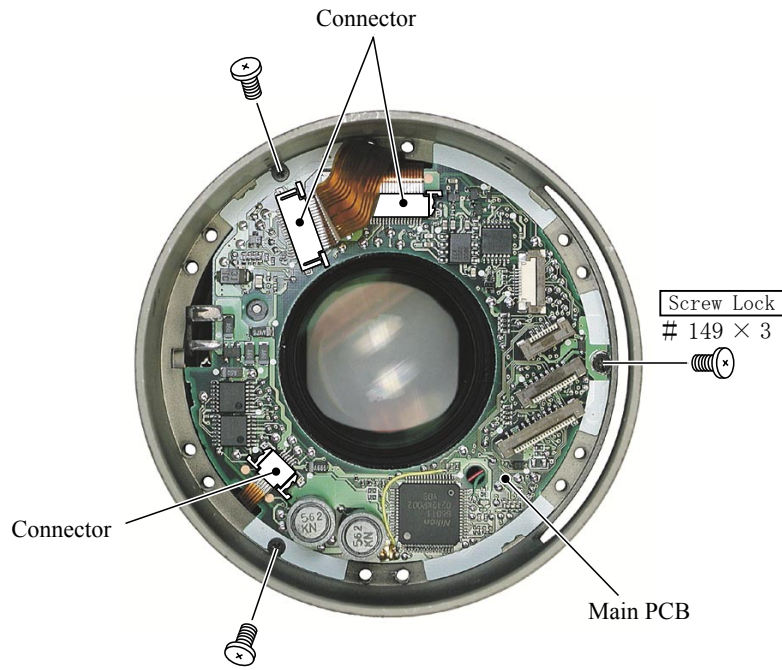

- ① Attach the main PCB with the 3 screws #149.
- ② Connect each FPC to the 3 connectors.

REAR GROUP

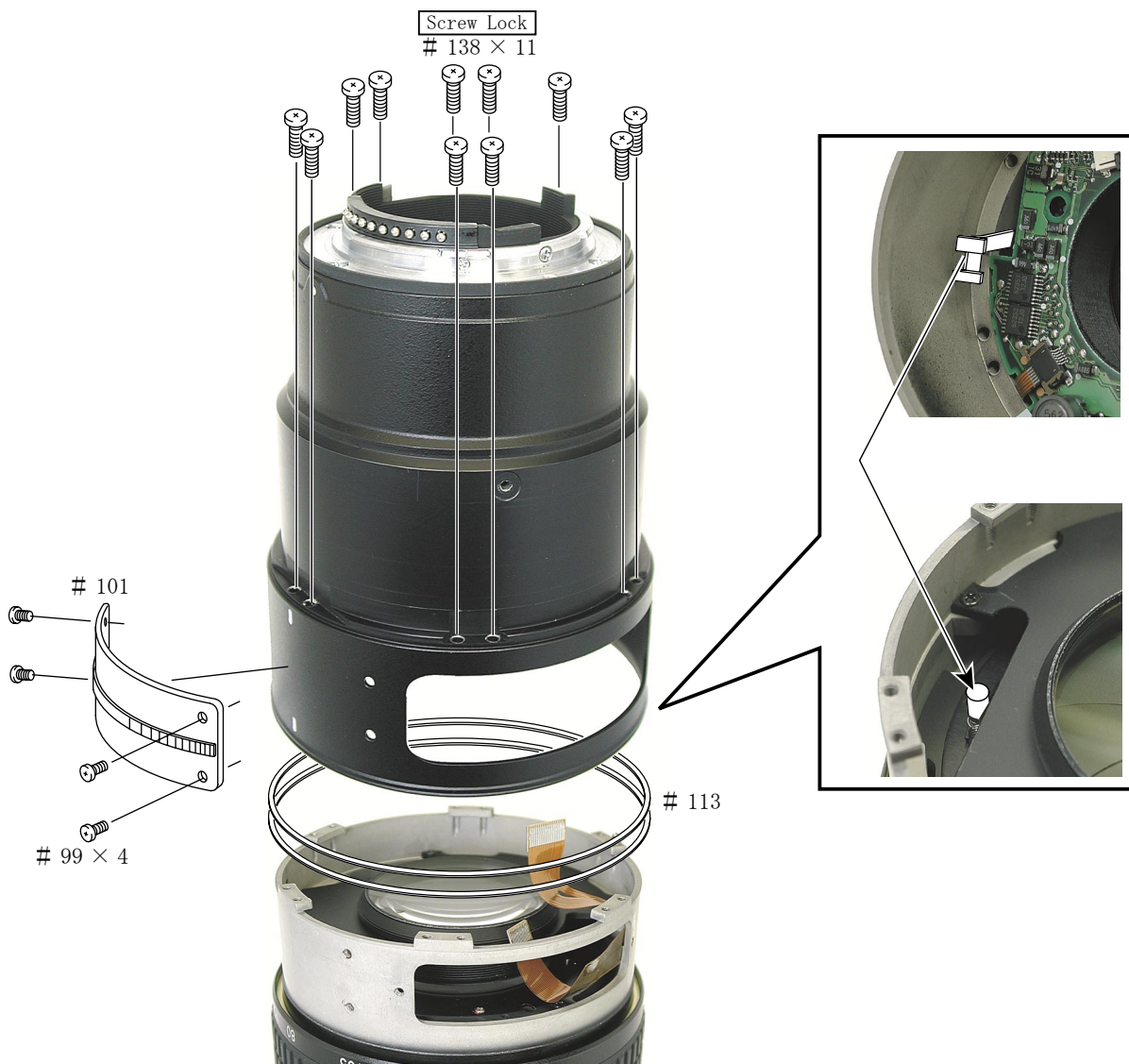

APERTURE DIAMETER ADJUSTMENT

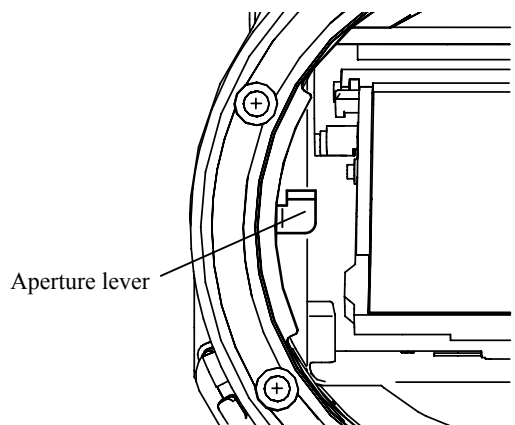

- ① Attach the lens to the camera body where the accuracy of the height in the aperture lever is adjusted.
- ② Check the condition of the aperture blades.
Standard: Full aperture.
- ③ In case it is not within the standard, adjust the position of the B8 by loosening the 2 screws #145.

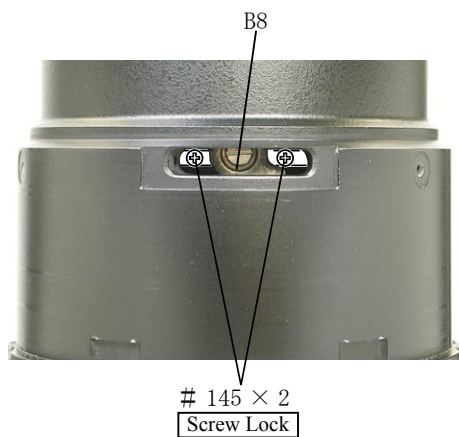

SELECTOR SWITCH UNIT

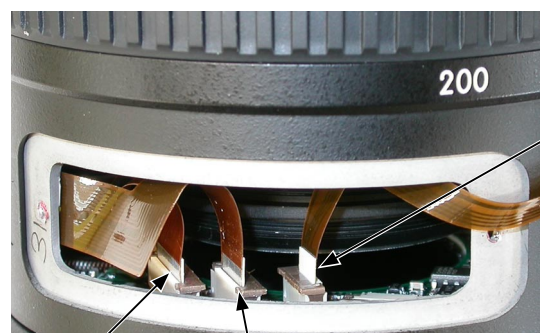

Connect the selector switch FPC.

Note:

The FPC contact face of the change-over SW is connected in the different direction from those of the other two.

Connect the linkup FPC.

Connect the zoom encoder. FPC

- Connect each FPC to the connectors and attach the group unit of selector switch B107.



2nd LENS GROUP

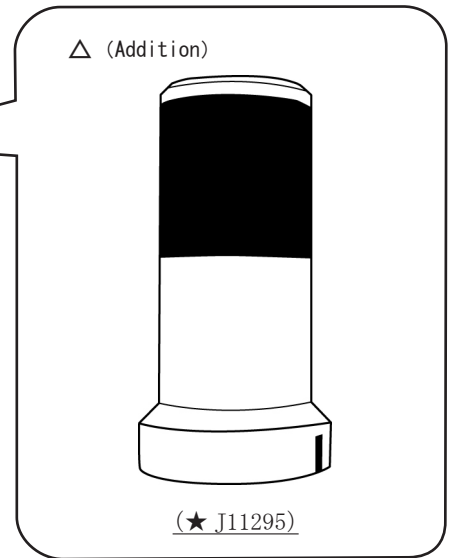

G4 ~ G5 LENS

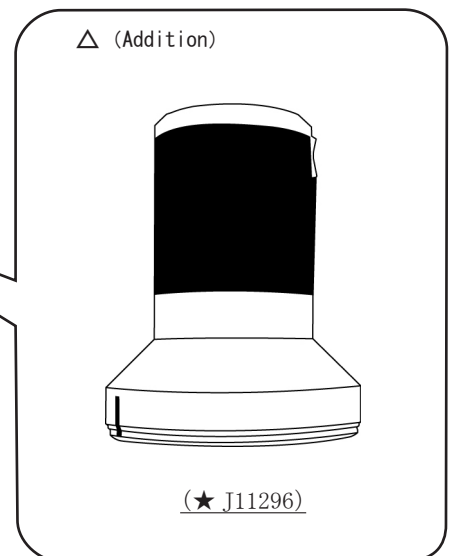
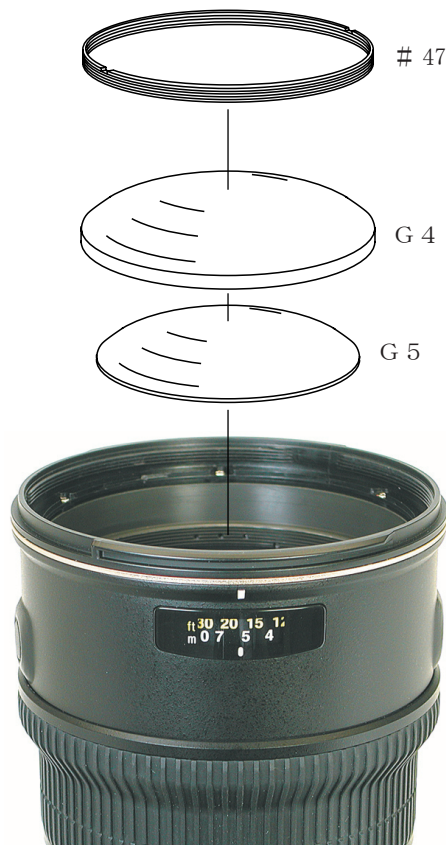

1st LENS GROUP



ADJUSTMENT (DIVISION) OF FOCUS MOVEMENT (T, W)

1. Fit the infinity (∞) mark of the focus ring to the index.
2. Fix the aperture lever to make the aperture "full".
3. Read the values of the Wide and Tele sides.
4. Carry out the following calculations.

$$(A - B) \div 1.5 = C$$

A = Value of Tele side

B = Value of Wide side

C = Adjustment amount (mm) of the 1st lens group unit washer #190

5. Adjust the thickness of the washer #190 by the value of C calculated in the above. If C is positive, thicken the washer. If it is negative, thin the washer. (Refer to P. L44.)

Note : When setting the washer #190, put a thin washer between thick washers.

ADJUSTMENT OF BACK FOCUS

1. Fit the infinity (∞) mark of the focus ring to the index.
2. Fix the aperture lever to make the aperture "full".
3. Read the value of Wide or Tele side.
4. Remove the bayonet mount.
5. Adjust the thickness of the washer #115 by the difference from the standard value. If the difference value is positive, thicken the washer. If it is negative, thin the washer. (Refer to P. L37.)

Focal length (f)	Standard (mm)
70 mm	-0.06 ~ +0.15
80 mm	-0.06 ~ +0.15
135 mm	-0.10 ~ +0.15
200 mm	-0.10 ~ +0.20

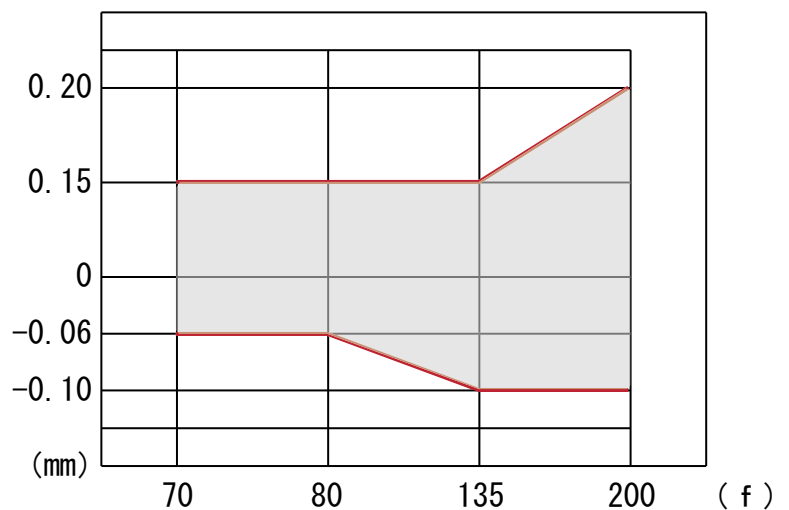

PREPARATION FOR INSPECTION AND ADJUSTMENT OF MAIN PCB

- In case of replacing the main PCB, SWM unit or MR encoder unit, be sure to adjust the following items due to a necessity on the operation.

1 . Items to adjust

- Adjustment of MR duty
- Adjustment of driving frequency and motor control

2 . Equipment and tools to be required

- Single output rated voltage power supply: 1 unit
For contact A to mount: Output of the DC/DC converter (5.5V 100mA)
For contact F to contact G: 6.0V 3.0A
- Oscilloscope: 1 unit for adjusting the MR duty/adjusting the driving frequency and motor control
- AF-I communication box (J15306 or J15306-1): 1 unit
- AF-I communication adapter (J15307): 1 unit

【System configuration diagram】

By using the DC/DC converter, 1 unit of rated voltage power supply can be energize this system fully.

The following figure shows the system using the DC/DC converter for F100. The system will be explained hereafter on the assumption that this modification has been done.

In J15306-1 of AF-I communication box, the DC/DC converter is already built in.

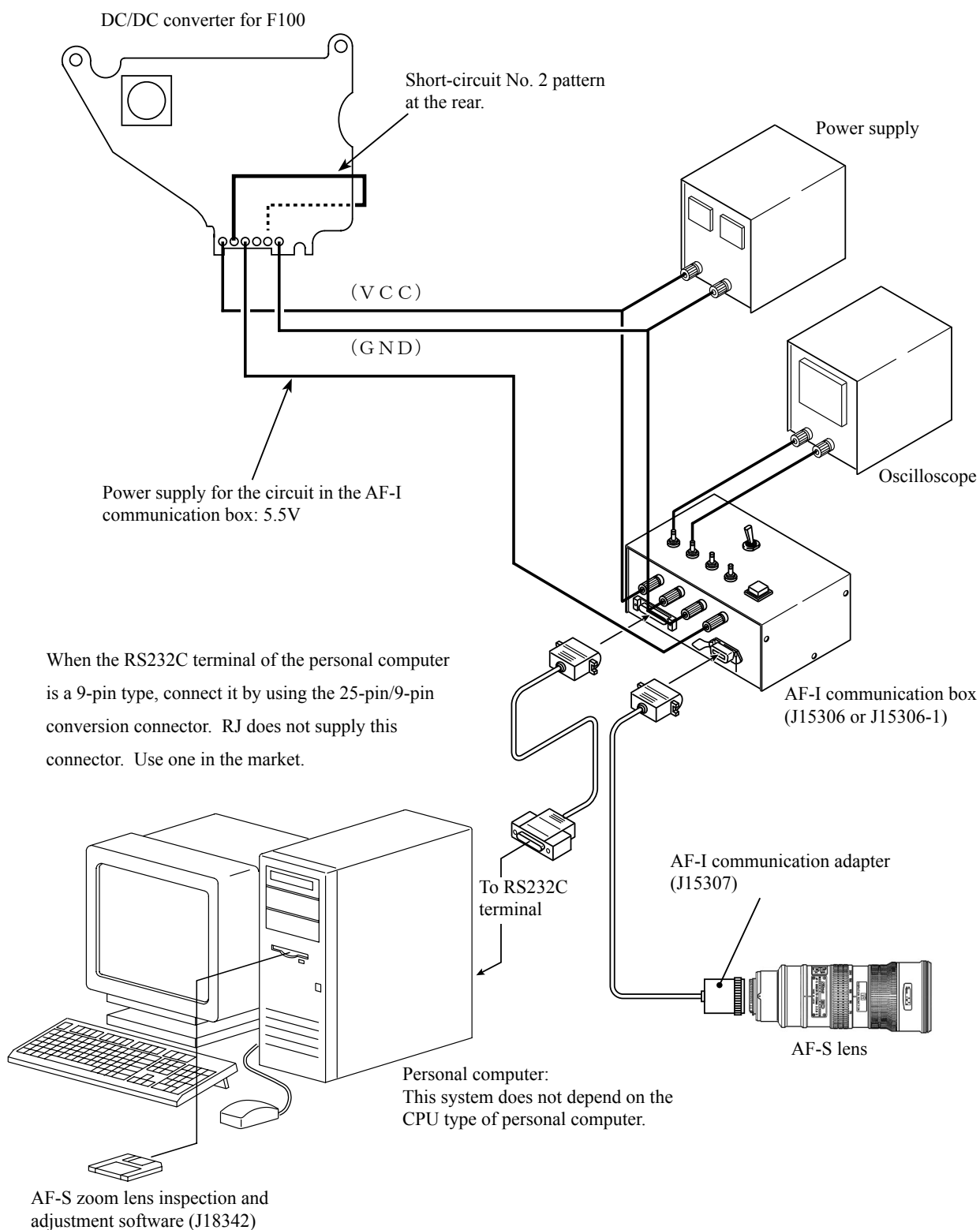

ADJUSTMENT FOR MR DUTY

- In case of replacing the main PCB, SWM unit or MR encoder unit, be sure to make this adjustment.

How to adjust

- ① Make sure that the current and voltage of the connected rated voltage power supply are the set values.
Then, turn on the rated voltage power supply for the contacts A and F.
- ② Select "1. MR DUTY ADJUSTMENT" in the menu items of the AF-S zoom lens (New) inspection program.
- ③ The display to check whether the fixed values are written in EEPROM or not appears. Select a proper item.
- ④ According to the instruction on the screen, rotate the MF ring from the infinity direction to the near distance direction slowly by hand. Make sure that the waveform on the oscilloscope has duty 50% and then stop the MF ring at the near distance end.

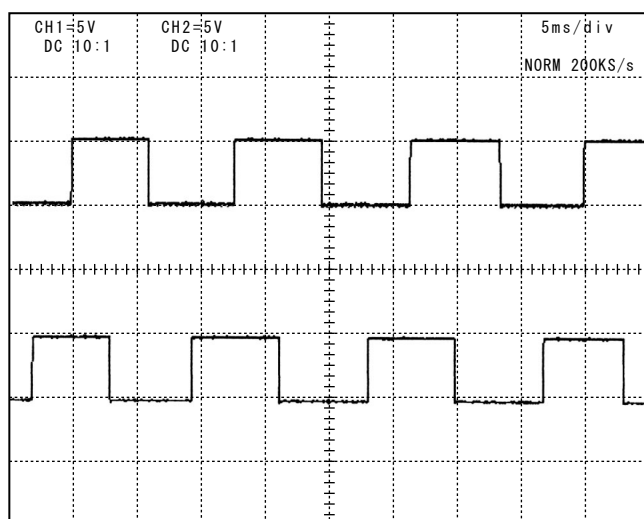

● Setting of oscilloscope

V/Div (CH1)	: 5 V
V/Div (CH2)	: 5 V
Coupling	: D C
Time/Div	: 5 m Sec
Trigger Mode	: NORMAL
Trigger Coupling	: D C
Trigger Source	: C H 1
Trigger Position	: + 4 div
Trigger Type	: EDGE
Trigger Level	: 2.5 V

- ⑤ According to the instruction on the screen, rotate the MF ring from the near distance direction to the infinity direction slowly by hand. Make sure that the waveform on the oscilloscope has duty 50% and then stop the MF ring at the infinity end.

Note : If the waveform from infinity to near distance and vice versa does not have duty 50%, perform again "INSPECTION AND ADJUSTMENT FOR THE WAVEFORM OUTPUT FROM MR ENCODER" in P.L20.

Standard $H : L = 100 : 206 \sim 206 : 100$ (50% ± 17.3%)

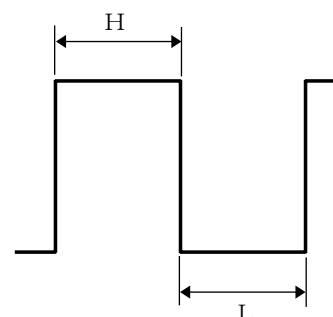

ADJUSTMENT OF DRIVING FREQUENCY AND MOTOR CONTROL

- In case of replacing the main PCB, SWM unit and MR encoder unit, be sure to make adjustments.
 - ① The method of connection of the rated voltage power supply and measuring tools is the same as "ADJUSTMENT OF MR DUTY".
 - ② Make sure that the electric current and voltage of the rated voltage power supply are set to the set values.
 - ③ Turn the rated voltage power supply ON.
 - ④ Select "2. ADJUSTMENT FOR DRIVING FREQUENCY & MOTOR CONTROL" in the menu of the AF-S zoom lens (New) inspection program. The lens automatically starts the driving of scanning.

TYPE OF LENS : AF-S VR NIKKOR 70-200mm/2.8G	CPU VERSION : 5.02.04
ADJUSTMENT FOR DRIVING FREQUENCY & MOTOR CONTROL.	
ADJUSTMENT IS COMPLETED.	
DOES THE MOTOR STOP DRIVING ? Yes = 1 No = 2	
SELECT THE NUMBER	
PUSH ESC KEY TO RETURN TO MENU	

- ⑤ In case the motor driving remains stopped when the above screen appears, select "1" to end the adjustment. If the motor drive does not stop, select "2" and make the following manual adjustment. If a proper adjustment is not made even after selecting "1", "COULD NOT BE EXECUTED." is displayed, followed by the manual adjustment.
If the adjustment cannot be made even by the manual adjustment, SWM unit or cam ring unit is regarded as malfunctioning.

⑥ Manual adjustment

In case the motor does not stop or automatic adjustment cannot be made, “Fig. 1” is displayed on the screen. At this moment, pressing “1” performs the automatic adjustment again.

If the adjustment cannot be made even after making several automatic adjustments, press “2” for manual adjustment in the following screen.

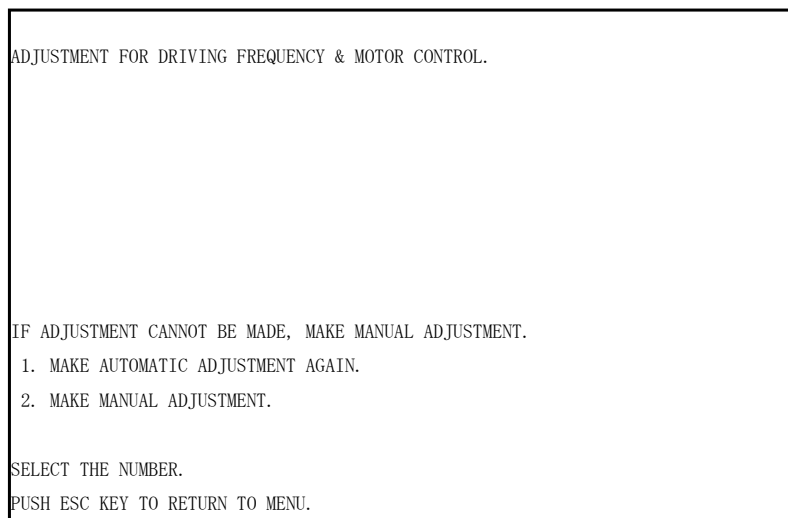

Fig. 1

First, make a low-speed adjustment then a high-speed adjustment.

1. Based on “Fig. 2” on the screen, set the low-speed adjustment for lens and oscilloscope.
 - Connect the probe of the oscilloscope to the E terminal of the communication-BOX.
 - Connect GND of the probe to GND of the communication-BOX.
2. Set the oscilloscope so that the time of one cycle of the waveform for E terminal of AF-I communications BOX can be seen.
 - The time of waveform varies according to the key operation of “1”, “3”, “4”, and “6”, so adjust the time within standard.
 - The standard shows average value, so sometimes it is acceptable to become an out-of-standard value.
3. Make a high-speed adjustment by following the above same procedure. (Be careful of a different value of standard.)

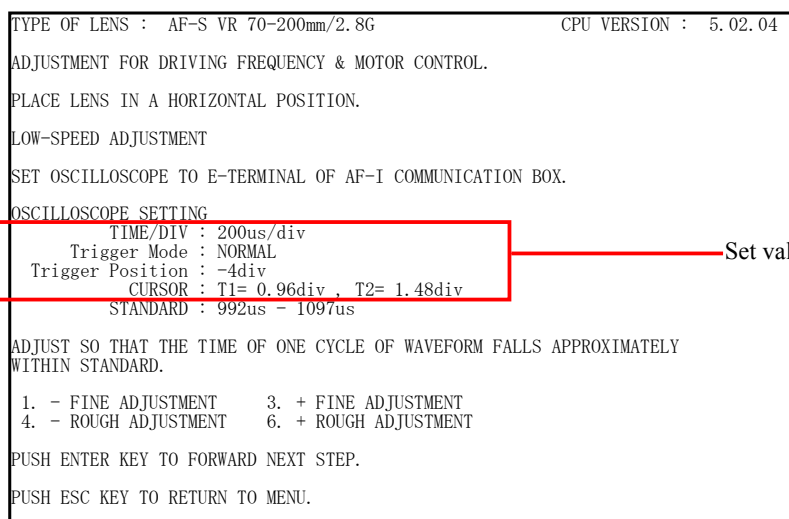

Fig. 2

e.g.) Oscilloscope (DL1540) setting

As shown in Fig. 2, “div” value within standard is displayed on PC screen.

As shown in Fig. 3, it becomes easy to judge if the standard range of cycle of waveform is set by cursor.

The standard value, TIME/DIV, and CURSOR(T1,T2) varies according to the conditions of low-speed adjustment, high-speed adjustment, and other lenses, etc, so check by Fig. 2 of the PC screen when adjustment is made.

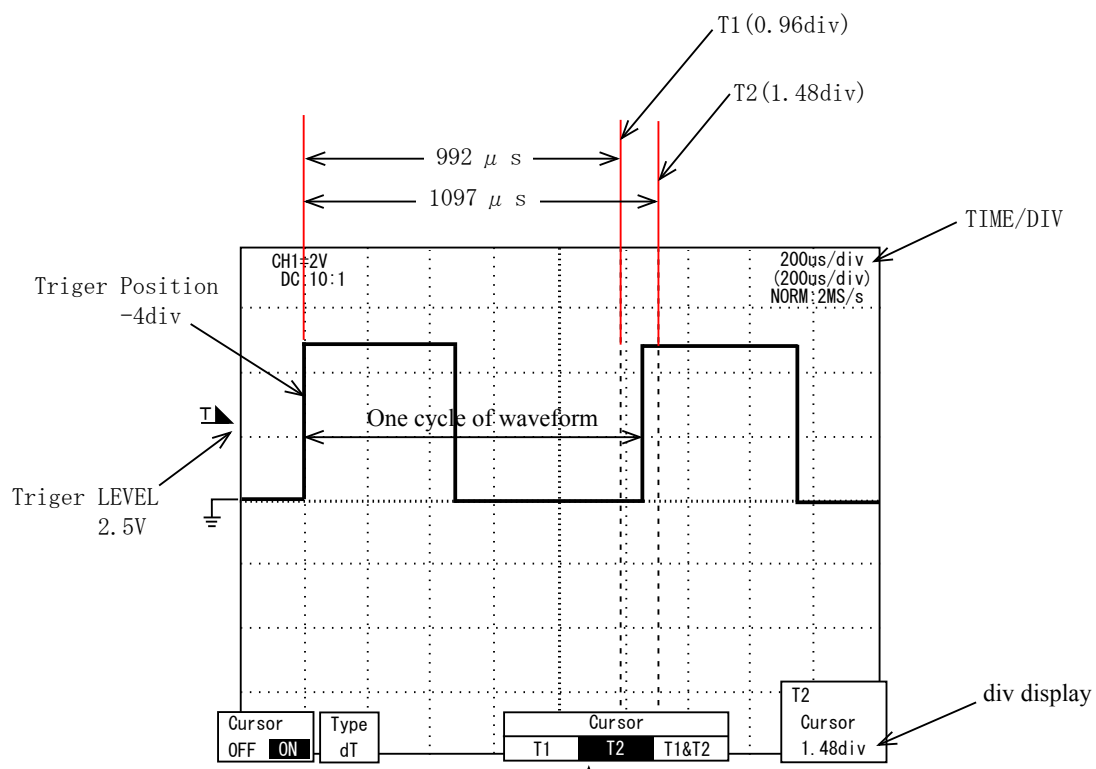

Fig.3 ↑ T1/T2Cursor switch-over

LENS OPERATION CHECK

Check the lens operation by using a personal computer after assembling.

○ Check by using a personal computer

● Check items

1 . Operation of MR encoder

- Drive the lenses for scanning and check the difference in pulses at start and at end.
- In case the MR encoder's MR head is not properly attached on the magnetic tape, the difference in pulses is larger.

2 . Lens servo stop accuracy

- Check the overrun/underrun pulses (misalignment of the stop position against the aimed position) for the specified lens actuation.
- When mechanical irregular operation does not occur in the focus ring drive unit, underrun occurs if the cam ring rotary weight of the MR encoder is heavy and overrun occurs if it is light.

3 . Lens servo time

- Check the servo time (time from servo start to stop) with an oscilloscope when the specified lens is actuated.
- When mechanical irregular operation does not occur in the focus ring drive unit, the servo time is long if the cam ring rotary weight of the MR encoder is heavy and is short if it is light.

4 . Check of switches and lenses

- Check the ON/OFF operation of switches and the operation of the distance encoder and zoom encoder.

● How to treat after inspection

1 . When the MR encoder operation is out of standard:

Adjust the MR duty again. (Refer to P. L48.)

If the pulse is out of the standard, adjust the output pulse/waveform from the MR encoder again. (Refer to P. L20.)

If the pulse meets the standard, replace the cam ring unit.

2 . When the lens servo stop accuracy is out of the standard:

Check the output pulse/waveform from the MR encoder. If it is normal, replace the cam ring unit.

3 . When the lens servo time is out of the standard:

Adjust the driving frequency and motor control again.

If the lens servo time is still out of the standard after the readjustment, replace the cam ring unit.

4 . When switches do not operate properly:

Check the wiring pattern of such troubled switch or replace it.

● Explanation of the AF-S zoom lens (New) inspection program

(1) Menu display

```

NIKON AF-S ZOOM LENS (NEW) INSPECTION / ADJUSTMENT PROGRAM. [J18342]
1. ADJUSTMENT FOR MR DUTY. 9. -----
2. ADJUSTMENT FOR FREQUENCY & CONTROL. A. -----
3. READ AND REWRITING OF EEPROM DATA. B. -----
4. OPERATION OF MR ENCODER. C. -----
5. LENS DRIVING STOP ACCURACY. D. -----
6. LENS SERVO TIME. E. -----
7. SWITCHES AND LENS CONDITION. F. -----
8. ----- G. RETURN TO THE SYSTEM.

SELECT THE DEMANDED ARTICLE BY <- -> KEY, AND PUSH ENTER KEY. OR, SELECT
COMMUNICATE BY RS232C TERMINAL.
THE DEMANDED ARTICLE BY ITS NUMBER. FOR IBM PC/AT DOS/V CLONE. (486-PENTIUM3)
COPYRIGHT (C) 2003-02-05 NIKON CORP.
BORLAND C++ VERSION 3.1 COPYRIGHT (C) 1992 BORLAND INTERNATIONAL.
    
```

• Menu items

The items 1 and 2 are used for adjustment.

The item 3 is used for reading and writing EEPROM DATA.

The items 4~7 are used for inspection.

• Selection of item

After selecting any item, one of the lens selection display, the focal length selection display, the voltage setting display, the inspection start display, etc. appears. The displays are different for the items. Obey the instructions of a personal computer.

• Operating voltage

	Power supply for AF motor in lens	Power supply for AF-I communication box
Inspection of MR encoder operation	6 . 0 ± 0 . 1 V	5 . 5 ± 0 . 2 V
Inspection of lens servo stop accuracy	6 . 5 ± 0 . 1 V	
Inspection of lens servo time	6 . 5 ± 0 . 1 V	
Inspection of switches and lenses	6 . 0 ± 0 . 1 V	

• Initial driving

When "WAIT FOR SOME SECOND" is displayed, execute initial driving (repeat scanning five times and stop at infinity end).

(2) Display of "OPERATION OF MR ENCODER"

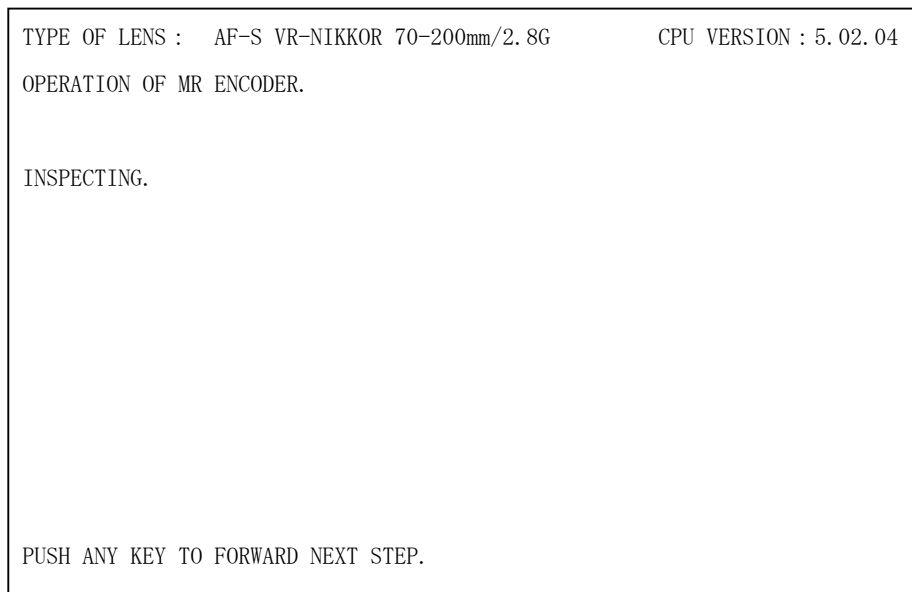

Note : If the MF ring is rotated during lens scanning, an error value is shown for the pulses. Don't touch the MF ring during operation.

Execute inspection for the 5 postures as mentioned below.

(Lens posture at inspection)

Lens inclination	Position of index window
Horizontal	Up, right and left
Front lens group 90° upward	
Front lens group 90° downward	

When the inspection is ended, the above display appears.

Press any key, and the inspection result in the next page appears.

The difference between the pulses before and after inspection must be within the standard.

Standard of difference between the pulses : 0 ± 10 PULSE(S)

Standard of all pulses : 6135 ± 125 PLUSE(S)

```
TYPE OF LENS : AF-S VR-NIKKOR 70-200mm/2.8G          CPU VERSION : 5.02.04
OPERATION OF MR ENCODER.

POSITION WHEN CHECK BEGINS. [PULSE(S)] ----- 7993
POSITION WHEN CHECK IS ENDED. [PULSE(S)] ----- 7992
PULSE NUMBER DIFFERENCE BEFORE / AFTER CHECK. [PULSE(S)] --- 1
STANDARD FOR DIFFERENCE IN THE NUMBER : FROM -10 TO 10 [PULSE(S)]
                                           IN STANDARD.
*****
THE TOTAL NUMBER OF PULSE(S) AT INSPECTION. [PULSE(S)] --- 6107
STANDARD FOR THE NUMBER : FROM 6010 TO 6260 [PULSE(S)]
                                           IN STANDARD.

PUSH ESC KEY TO RETURN TO MENU.
```



(3) Display of "INSPECTION OF DRIVING STOP ACCURACY"

	TYPE OF LENS : AF-S VR-NIKKOR 70-200mm/2.8G	CPU VERSION : 5.02.04
	INSPECTION OF DRIVING STOP ACCURACY.	
①	NUMBER OF LENS GO-AND-RETURN OPERATIONS.	: 5 / 5 TIME(S).
	LENS DRIVING TIMES. (DF0+DF1+DF2+DF3+DF4+DF5+DF6)	: 290 TIME(S).
	MAXIMUM PULSE. (ABSOLUTE) (DF0+DF1+DF2+DF3+DF4+DF5+DF6)	: 3 PULSE(S).
	OVER (OR UNDER) RUN PULSE(S).	: -1 PULSE(S).
	LENS DRIVING TIMES. : DF1=50 DF2=50 DF3=50 DF4=50 DF5=40 DF6=40	
	DIRECTION : INF -) CLOSE CLOSE -) INF	
	AMOUNT : DF1 DF2 DF3 DF1 DF2 DF3	
	UNDER(-), OVER(+)	(-) (+) (-) (+) (-) (+) (-) (+) (-) (+) (-) (+)
	0 - 6	: 3 22 0 25 0 25 25 0 25 0 25 0
	7 - 18	: 0 0 0 0 0 0 0 0 0 0 0 0
	12 - 18	: 0 0 0 0 0 0 0 0 0 0 0 0
④	19 -	: 0 0 0 0 0 0 0 0 0 0 0 0
	DIRECTION : INF -) CLOSE CLOSE -) INF	
	AMOUNT : DF4 DF5 DF6 DF4 DF5 DF6	
	UNDER(-), OVER(+)	(-) (+) (-) (+) (-) (+) (-) (+) (-) (+) (-) (+)
	0 - 6	: 1 24 1 19 0 20 25 0 20 0 20 0
	7 - 18	: 0 0 0 0 0 0 0 0 0 0 0 0
	12 - 18	: 0 0 0 0 0 0 0 0 0 0 0 0
⑤	19 -	: 0 0 0 0 0 0 0 0 0 0 0 0
②	RATIO(1) (%)	: Df1=0.00 Df2=0.00 Df3=0.00 Df4=0.00 Df5=0.00 Df6=0.00
③	RATIO(2) (%)	: Df1=0.00 Df2=0.00 Df3=0.00 Df4=0.00 Df5=0.00 Df6=0.00
	PUSH ESC KEY TO RETURN TO FOCAL DISTANCE SET-UP MENU.	

Note : If the MF ring is rotated during lens scanning, an error value is shown for the pulses. Don't touch the MF ring during operation.

The above display appears during lens driving. Execute the inspection for the 5 postures as mentioned below.

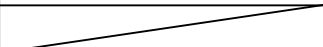
(Lens posture at inspection)

Lens inclination	Position of index window
Horizontal	Up, right and left
Front lens group 90° upward	
Front lens group 90° downward	

The pulses of overrun/underrun must be within the standards after the lenses have reciprocated five times ("5/5TIME (S)." in [1] of the display).

Standards RATIO (1) is 40% or less for Df1~Df6. ② of the display
 (Occurrence ratio of 7~18 pulses)

RATIO (2) is 10% or less for Df1~Df6. ③ of the display
 (Occurrence ratio of 12~18 pulses)

Occurrence of 19 or more pulses is zero for Df1~Df6. ④ and ⑤ of the display
 (It is malfunction if there is only one occurrence.)

※ "Df1~Df6" shows the lens driving amount.

(4) Display of "INSPECTION OF LENS SERVO TIME"

TYPE OF LENS : AF-S VR-NIKKOR 70-200mm/2.8G	CPU VERSION : 5.02.04
INSPECTION OF LENS SERVO TIME.	

SERVO AMOUNT.	STANDARD.
1. [Df1]	55ms OR LESS.
2. [Df2]	70ms OR LESS.
3. [Df3]	95ms OR LESS.
4. [Df4]	120ms OR LESS.
5. [Df5]	145ms OR LESS.
6. [Df6]	165ms OR LESS.

7. DRIVING TO INFINITY.	
8. DRIVING TO CLOSE.	
9. RETURNING TO FOCAL DISTANCE SET-UP MENU.	
SELECT A NUMBER.	
PUSH ESC KEY TO RETURN TO MENU.	

Connect the probes of oscilloscope to E and H terminals of the AF-I communication box (J15306). Select the servo driving amount one by one. Each of the lens servo drive time must be within the standard.

Note : If the MF ring is rotated during inspection, an error value is shown for the waveform. Don't touch the MF ring during inspection. Execute the inspection for the 5 postures as mentioned below.

(Lens posture at inspection)

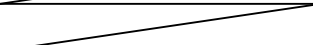
Lens inclination	Position of index window
Horizontal	Up, right and left
Front lens group 90° upward	
Front lens group 90° downward	

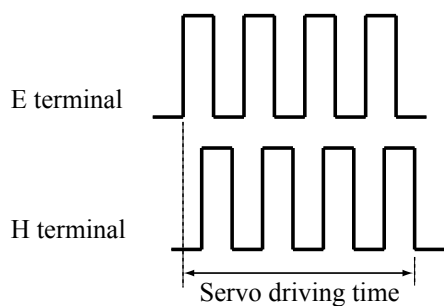

● Setting of oscilloscope

- V/Div : 5 V
- Coupling : DC
- Time/Div : 2 0 m Sec
- Trigger Mode : S G L (S)
- Trigger Coupling : DC
- Trigger Source : CH 1

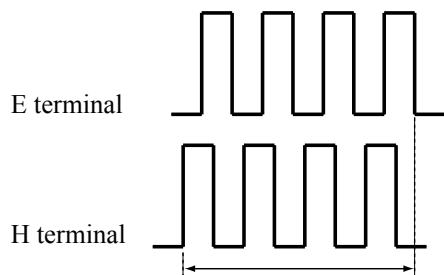

※ There are the start of going up and that of going down for the waveforms of E and H terminals.

(5) Display of "SWITCHES AND LENS CONDITION"

①	TYPE OF LENS : AF-S VR-NIKKOR 70-200mm/2.8G	CPU VERSION : 5.02.04	②
	SWITCHES AND LENS CONDITION.	: FOCUSING ENCODER ZOOMING ENCODER :	
		: 0-1 16 0-2 19 :	
		: 0-2 17 0-3 20 :	
③	FOCUSING ENCODER : 0-1	: 0-3 18 1 21 :	
	ZOOMING ENCODER : 0-2	: 0-4 19 2 22 :	
		: 0-5 20-1 3 23 :	
④	FOCUS MODE SELECTOR : M/A	: 1 20-2 4 24 :	
	FOCUS LOCK SW : OFF	: 2 20-3 5 25 :	
		: 3 6 :	
	FOCUS RANGE LIMITER SW : FULL	: 4 7 :	
		: 5 8 :	
		: 6 9 :	
⑤	HELICOID POSITION : INFINITY	: 7 10 :	
		: 8 11 :	
	VR ON-OFF SW : OFF	: 9 12 :	
		: 10 13 :	
		: 11 14 :	
	VR MODE SW : NORMAL	: 12 15 :	
		: 13 16 :	
		: 14 17 :	
		: 15 18 :	
	PUSH ANY KEY TO RETURN TO MENU.		

- ① Shows the type of lens.
- ② Shows the version of CPU in the lens.
- ③ Shows the signals of the distance encoder and zoom encoder.
This value is changed if the MF ring is rotated while the lens drive mode selector is at M or M/A.
- ④ Shows the status of switches.
- ⑤ Shows the helicoid position (near distance, medium distance or infinity) according to the distance encoder signal.

【System configuration】

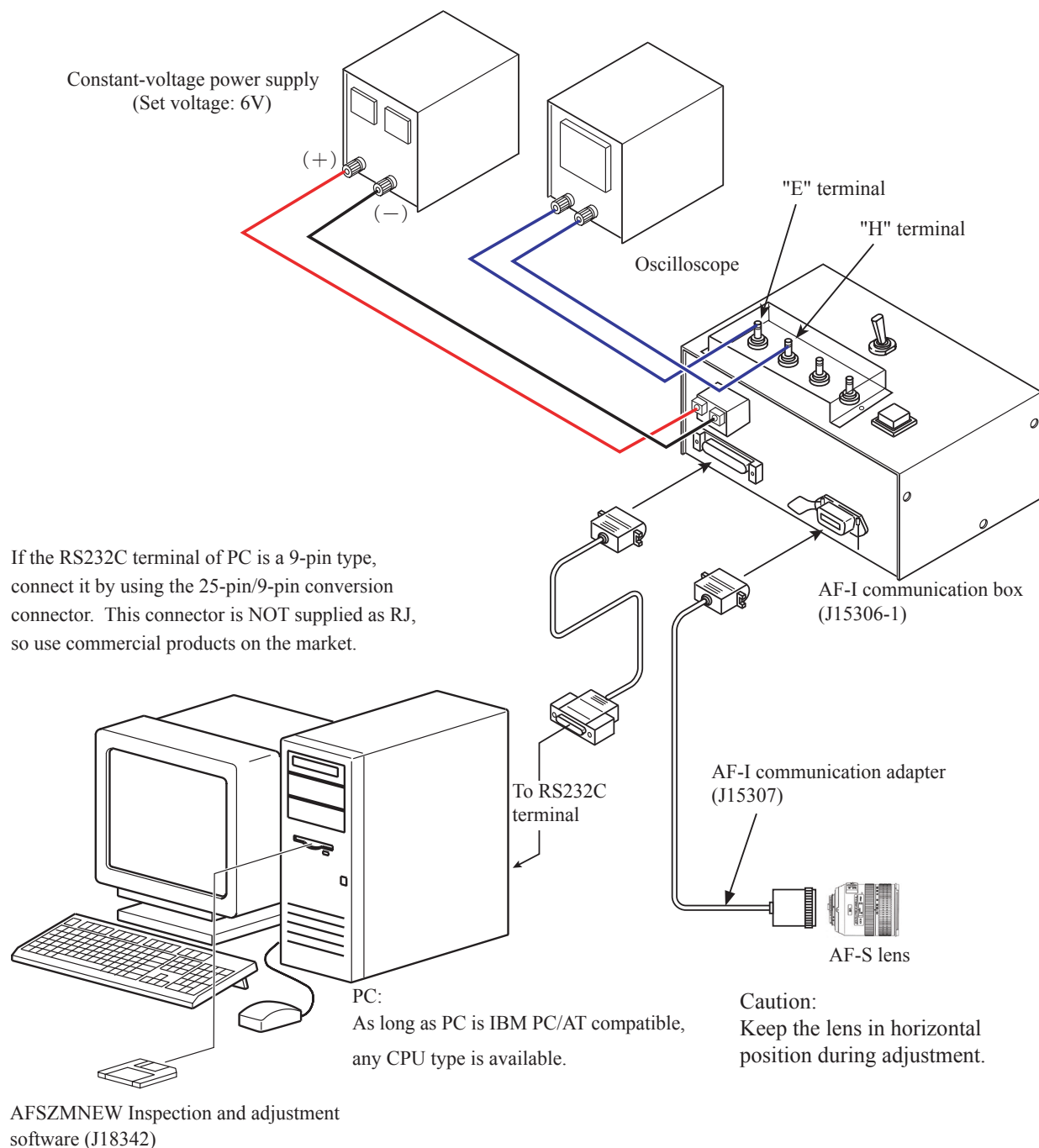

- AF-S Zoom lens (New) inspection program

- (1) Menu screen

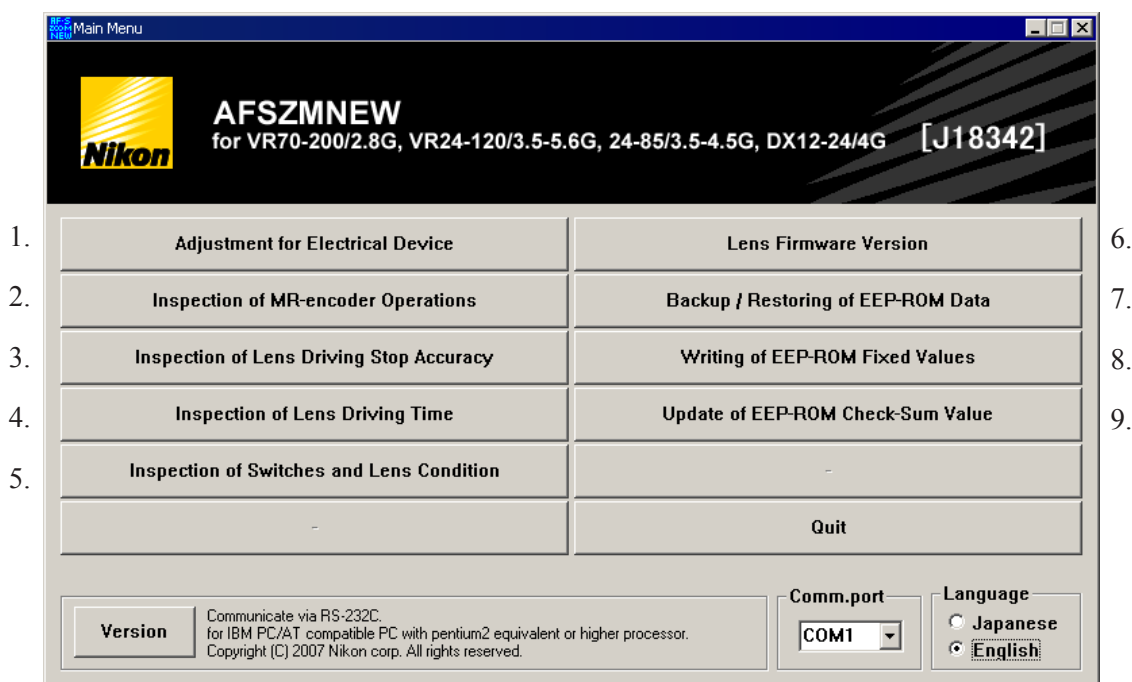

- Menu items

Items 1. is used for adjustments.

Items from 2. through to 5. are used for inspection

Item 6. is used for confirming firmware

Item from 7. through 9. are used for reading/writing EEPROM DATA.

- Selecting items

Depending on selected items, screens appear such as the lens selection, the focal length selection, the voltage setting, the inspection mode entering, etc.

Follow the instructions **on PC**.



Adjustment for electrical device

- When the main PCB or SWM unit or MR encoder is replaced, be sure to make adjustments.
- When the main PCB is replaced, be sure to perform "Writing of EEP-ROM Fixed Values".

How to adjust:

- ① Confirm that the electric current and voltage of the connected constant-voltage power supply are set to set values, and turn the constant-voltage power supply ON.
- ② Click "Adjustment for Electrical Device" on the menu of AFSMNEW (J18342) inspection program.
(Fig. 1)

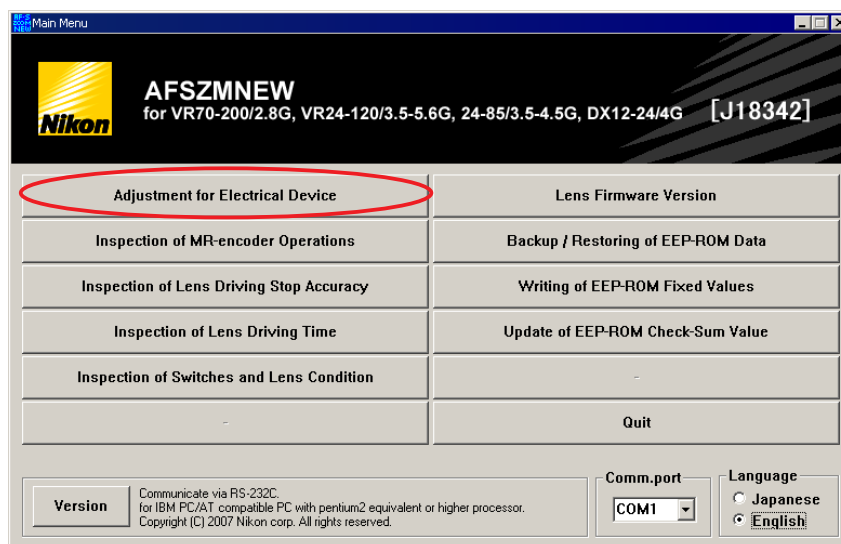

Fig.1

- ③ The screen for "Writing of EEP-ROM Fixed Values" appears. Click the appropriate item. (Fig.2)

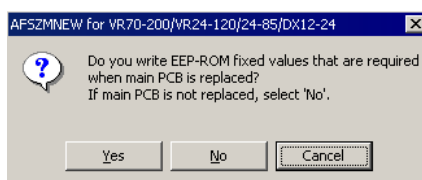

Fig.2

- ④ Following the instructions on the screen, rotate the MF ring in the direction from "Infinity-end" toward "Close-end" slowly by hand. (Fig.3)

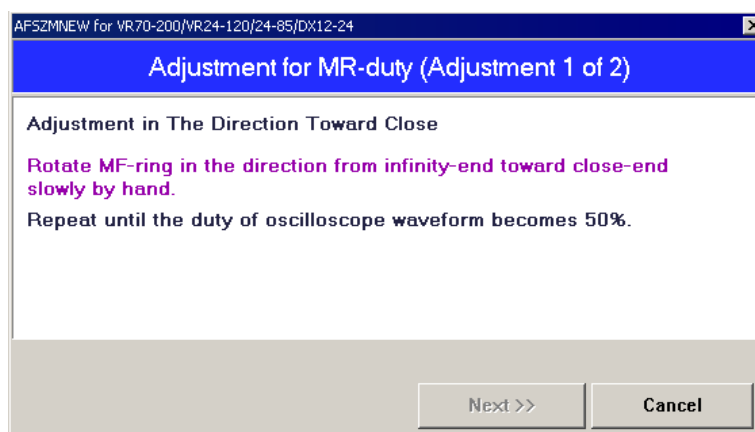

Fig.3

- ⑤ Confirm that the waveform on the oscilloscope has duty 50% and stop the MF ring at the close-end. (Fig.1)

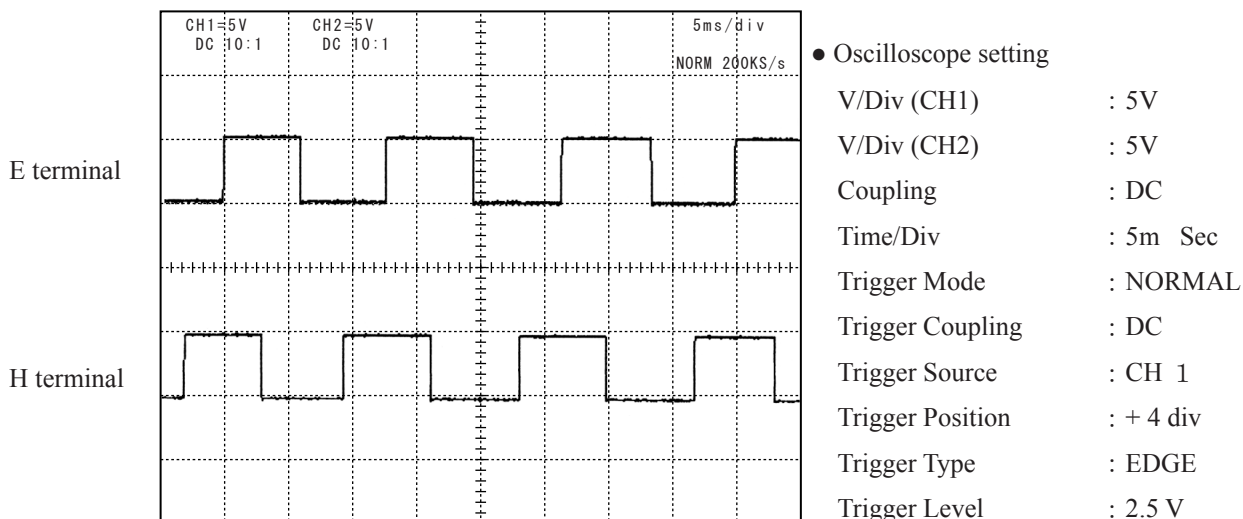

Fig.1

- ⑥ Following the instruction on the screen, rotate the MF ring in the direction from "Close-end" to "Infinity-end" slowly by hand.
 Confirm that the waveform on the oscilloscope has duty 50% and stop the MF ring at "Infinity-end". (Fig.2)

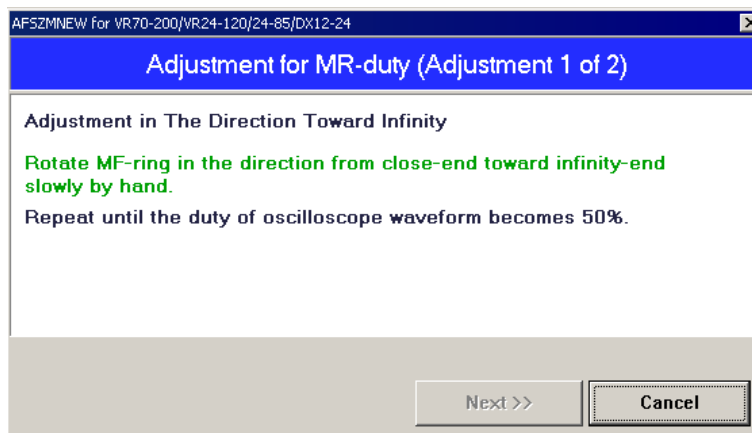

Fig.2

- ⑦ When the adjustment is completed, click "Next". (Fig.3)

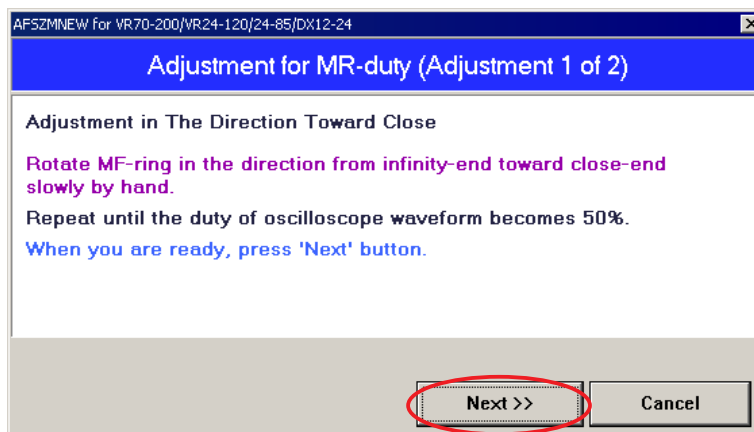

Fig.3



Caution:

If each waveform from "Infinity-end" to "Close-end", or "Close-end" to "Infinity-end" does not have duty 50%, perform "Inspection and adjustment of the MR encoder output waveform" on Page L20-L23 for readjustment.

Standard $H:L = 100 : 206 \sim 206 : 100$ (50% $\pm 17.3\%$)

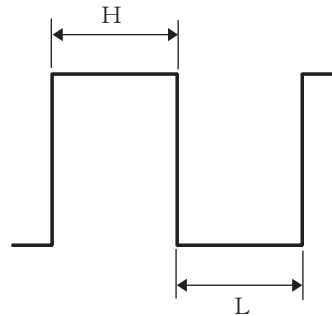

Drive frequency/motor control adjustments

Automatic adjustment

- When the main PCB or SWM unit or MR encoder is replaced, be sure to make adjustments.
- ① Complete the same procedure of the adjustment for electrical device, and click "Next". (Fig.1).
The lens starts scan-driving automatically. (Fig.2)

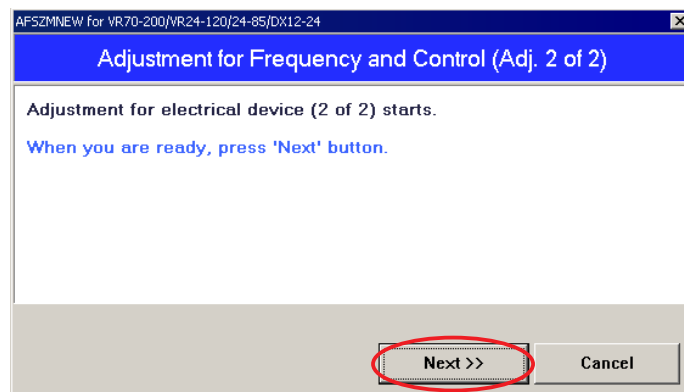

Fig.1

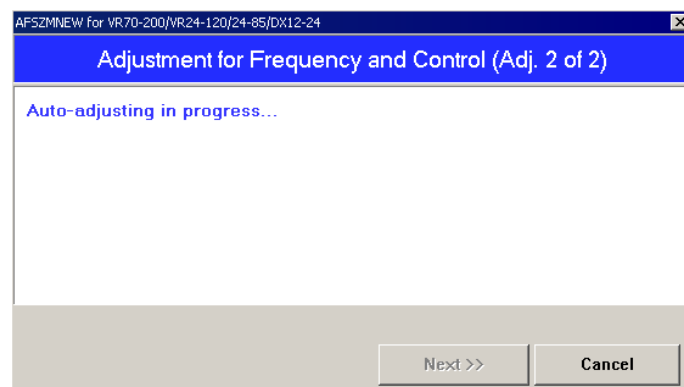

Fig.2



- ② When "Fig.1" screen appears, if the motor driving stands still, click "Close" to end the adjustment.

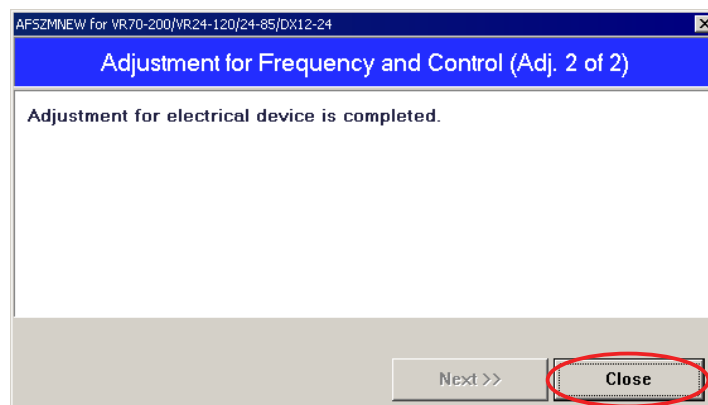

Fig.1

Manual adjustment

- ① If the automatic adjustment failed, "Adjustment could not be completed" (Fig.1) will appear. So click "Yes" and make the manual adjustment.

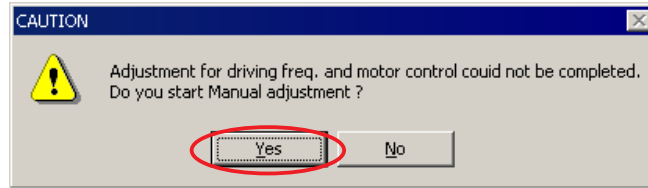
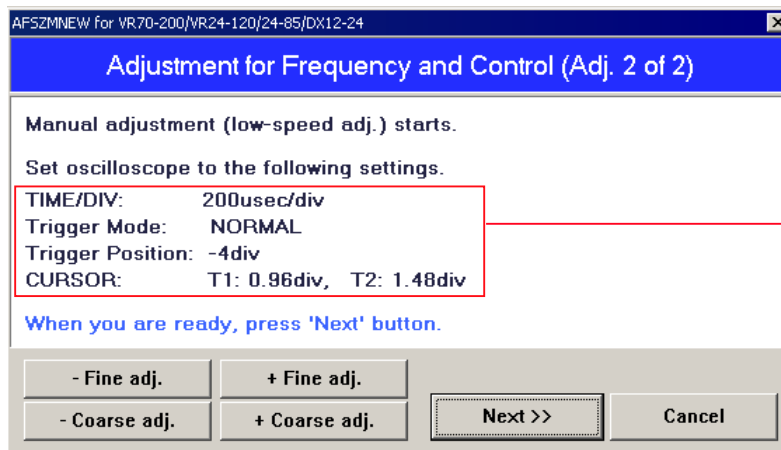

Fig.1

② Low-speed adjustment

1. Set the oscilloscope to the set values of "Fig.2", and make the low-speed adjustment of lens.
2. Click each adjustment of "A section" in "Fig.3", and adjust so that the values become within standards.
3. When the low-speed adjustment is completed, click "Next" of "Fig.3".



Set values of oscilloscope
(DL1540)

Fig.2

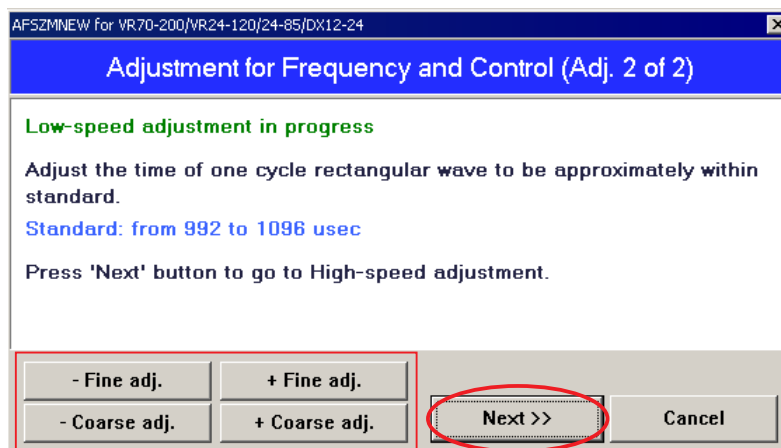

A section

Fig.3



③ High-speed adjustment

Make the high-speed adjustment of "Fig.4" by the same procedure as in the low-speed adjustment.

(Be careful, however, that the setting values are different.)

- When the adjustment is completed, click "Write adj.value" of "Fig.5".

If even the manual adjustment cannot be made, the SWM unit or MR head may be defective.

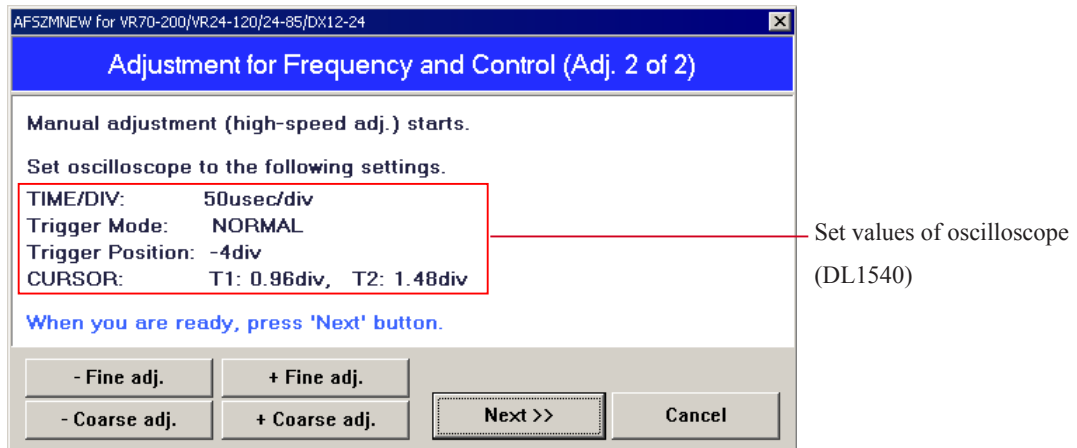

Fig.4

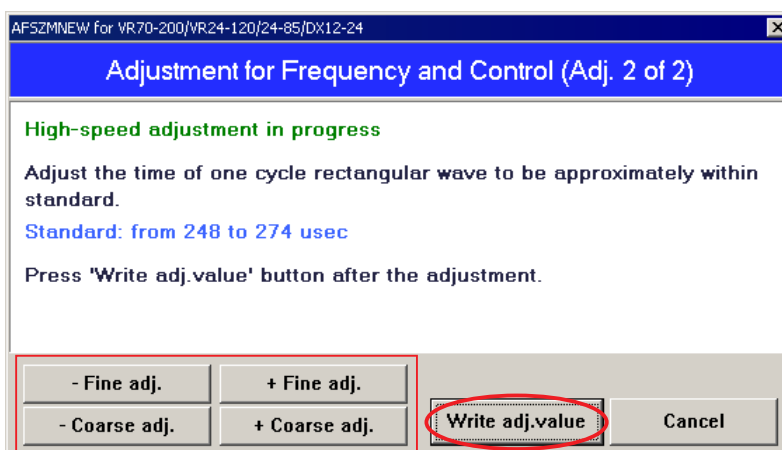

Fig.5

(2) Screen for inspecting MR encoder operation

- ① Click "Start insp." of "Fig.1".

Caution:

When the MR ring is roated during the lens-scan driving, the number of pulses shows an abnormal value.
So do NOT touch the MF ring in operation.

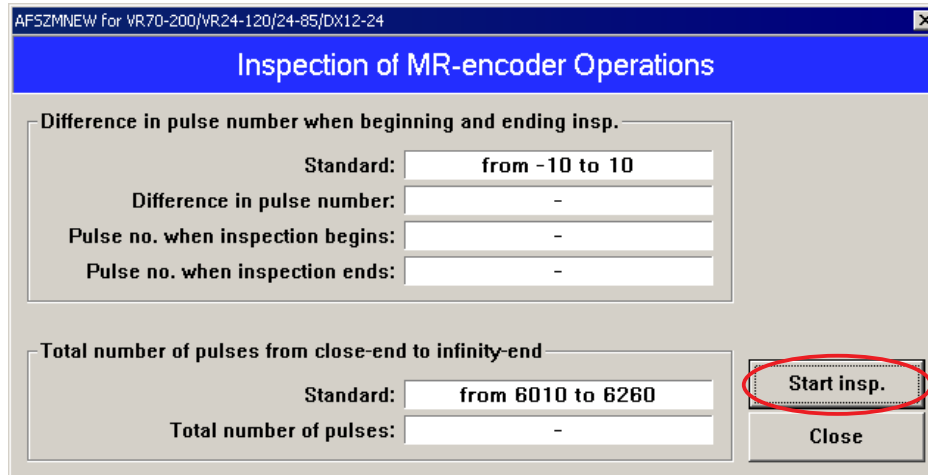

Fig.1

- ② When the operation check is completed, the result is displayed as shown in "Fig.2".
If there is no problem with the result, click "Close".
If there is some problem, make the readjustment by referring to Page L56-16.

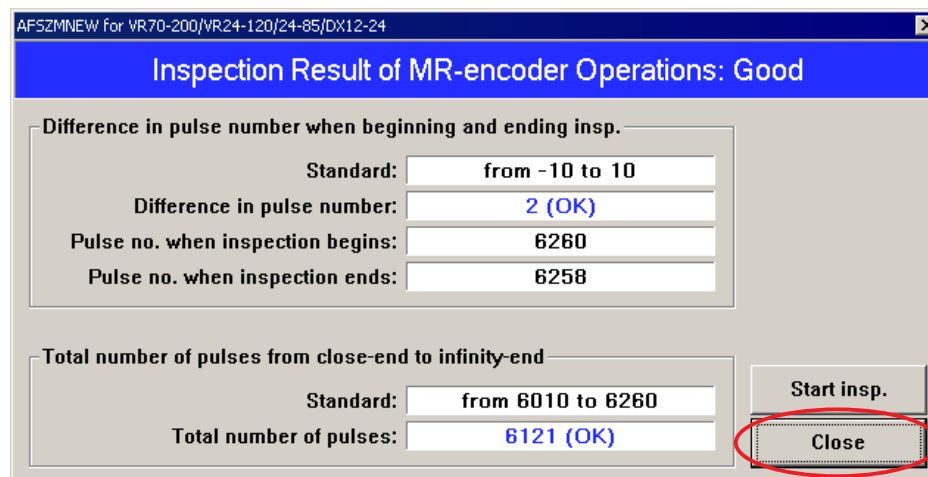

Fig.2

The difference in pulse no. when inspecting must be within standards.

Standard of "Difference in pulse no." : 0 ± 10 PULSE(S)

Standard of "Total no. of pulses": 6315 ± 125 PULSE(S)



(3) Inspection screen of lens driving stop accuracy

① Make this inspection on both focal length 70mm (W) and 200mm (T) at the following five lens positions.

(Lens position when inspecting)

Tilt of Lens	Position of index window
Horizontal	Up / Right / Left
Front lens group 90° angle upward	
Front lens group 90° angle downward	

- ① Click "Start insp.". The inspection of lens driving stop accuracy starts.
- ② If the lens stops during the inspection, input a figure [from "0" to "1000" (msec: millisecond) to delay the process] which prevents stopping the lens, into the below "Delay time" entry field.

Note:

The delay time is the setting value set by the adjustment software. So, if the lens does not stop during "Inspection of Lens Driving Stop Accuracy" in the end, any value can be input without problem. However, the larger the value of "ADJUST DELAY-TIME" gets, the longer the inspection time becomes.

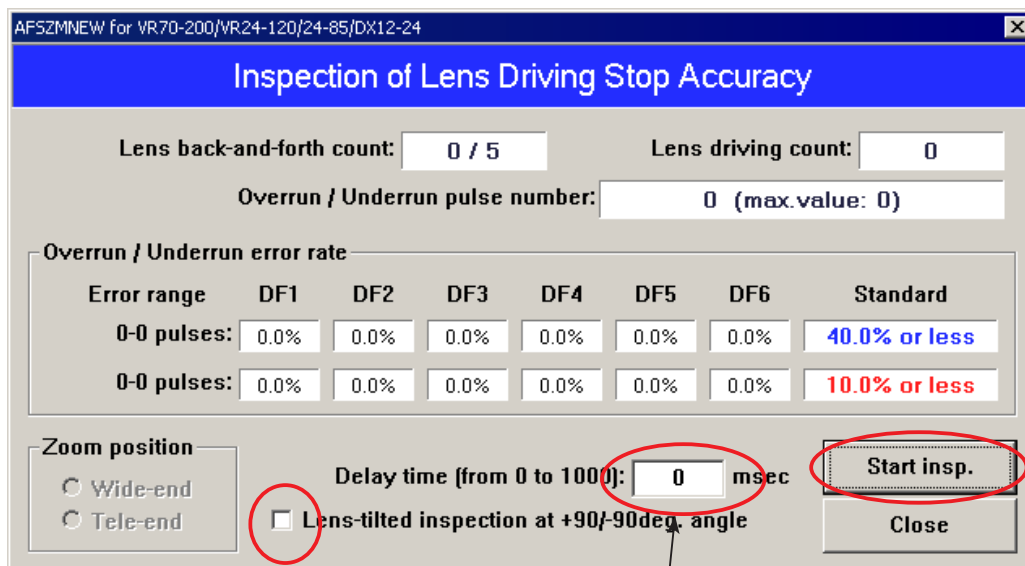

Tick the checkbox when
Front lens group 90° angle
upward/downward

Entry field

③ During the lens driving, the screen of "Fig.1" appears.

Caution:

When the MR ring is rotated during the lens-scan driving, the number of pulses shows an abnormal value.
So do NOT touch the MF ring in operation.

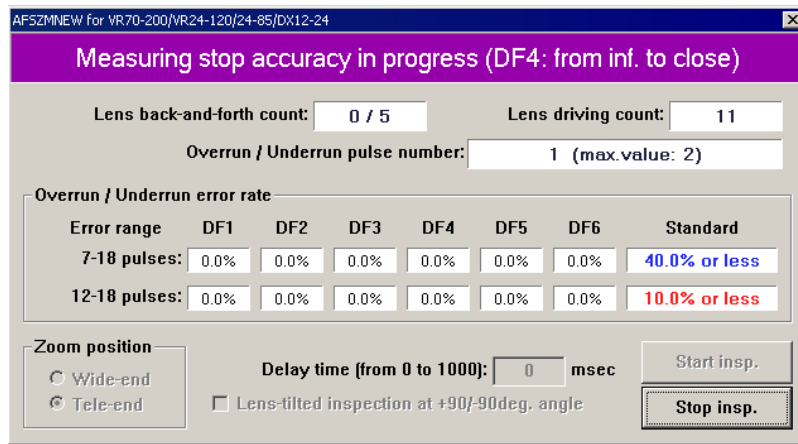

Fig.1

④ The number of overrun/underrun pulses must be within the standards after the lens back-and forth driving-motion five times ("5/5TIME (S).") in ① of Fig.2).

- Standard Df1~Df6: 40% or less ② of "Fig.2"
(7 - 18 pulse occurrence ratio)
- Df1~Df6: 10% or less ③ of "Fig.2"
(12-18 pulse occurrence ratio)
- 19-or-more pulse occurrence: 0 for DF1 ~ Df6 ④ of "Fig.2"
(Even only one occurrence is judged as defective.)

※ "Df1~Df6" shows the lens driving amount.

⑤ When the operation check is completed, the result is displayed as shown in "Fig.2".
If there is no problem with the result, click "Close".
If there is some problem, make the readjustment by referring to Page L56-16.

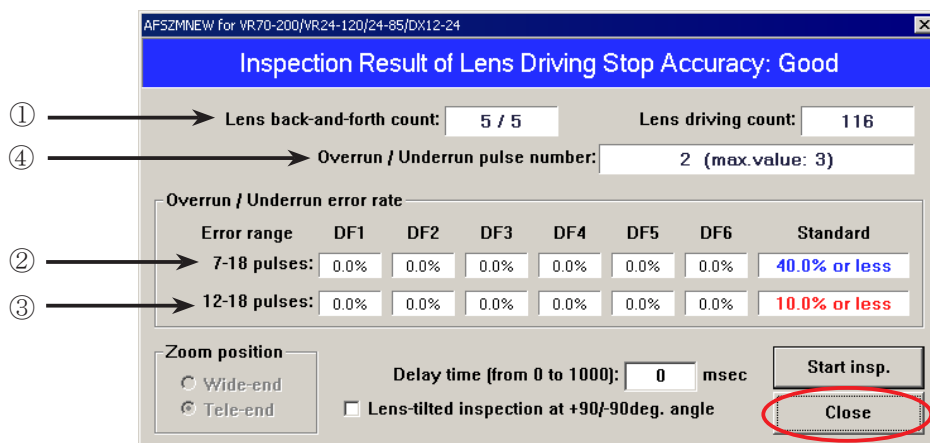

Fig.2



(4) Inspection screen of lens driving time

- ① Make the inspection on both focal length 70mm (W) and 200mm (T) at the five lens positions of "Fig.1".
- ② Select each driving amount. Confirm that each lens driving time is within the standard. (Fig.2)
- ③ If the inspection result is within standard, click "Close" to end. If any of each driving amount becomes out of standard, make the readjustment by referring to Page L56-16.

Caution: When the MR ring is roated during the inspection, the waveform shows an abnormal value. So do NOT touch the MF ring during the inspection.

(Lens position when inspecting)

Tilt of Lens	Position of index window
Horizontal	Up / Right / Left
Front lens group 90° angle upward	
Front lens group 90° angle downward	

Fig.1

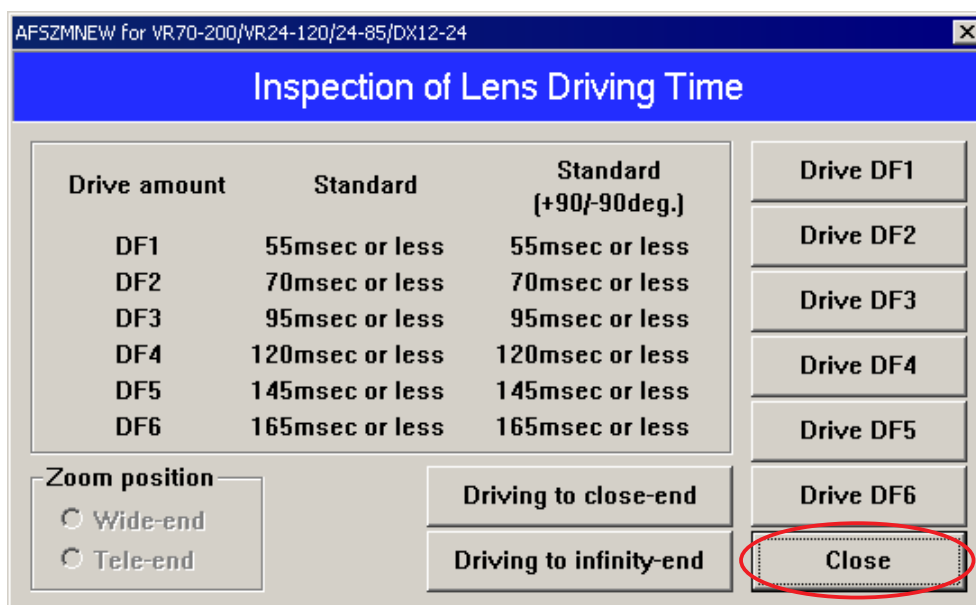
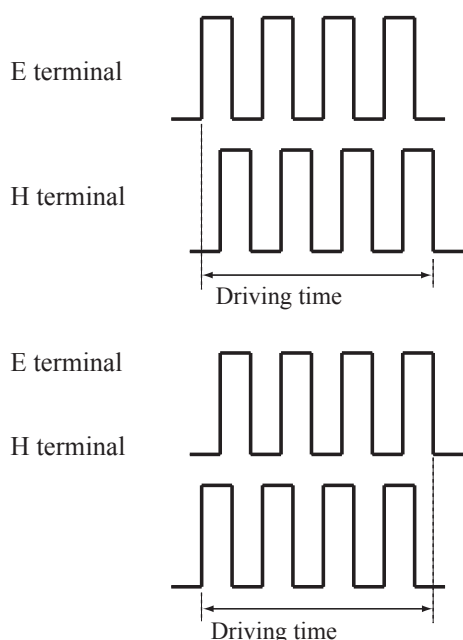

Fig.2



●Oscilloscope setting

- V/Div : 5V
- Coupling : DC
- Time/Div : 20 m Sec
- Trigger Mode : SGL (S)
- Trigger Coupling : DC
- Trigger Source : CH1

※ There are two types in shape of waveforms of E and H terminals:
Waveform (1) starts and goes up (2) starts and goes down.



(5) Inspection screen of switches and lens conditions

- If there is no problem with each item, click "Close" to end. If there is some problem, make the readjustment by referring to Page L56-16.

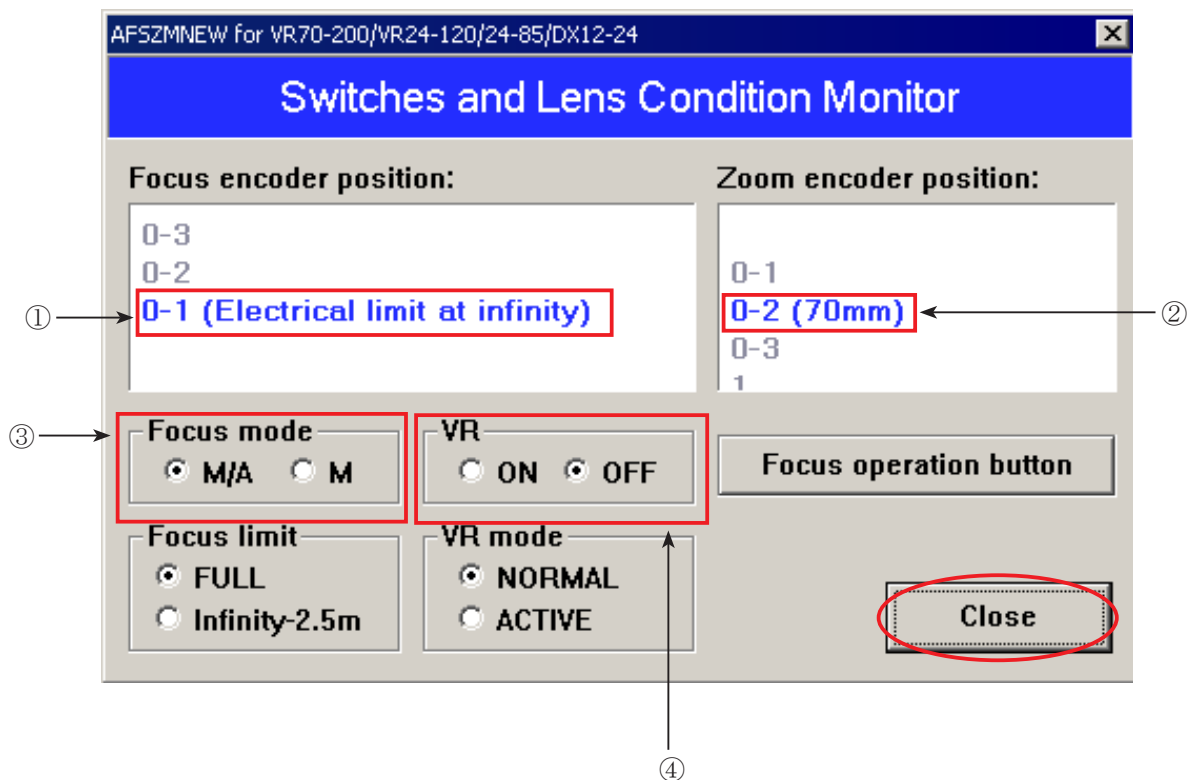

- ① Focus encoder signal
- ② Zoom encoder signal
- ③ Status of focus mode
- ④ Status of VR (vibration reduction) ON-OFF switch

Oscilloscope: Example of settings for DL1540

- "Fig.2" on Page L56-8 shows setting values for low-speed adjustment, while "Fig.4" on Page L56-9 shows those for high-speed adjustment.
- Setting T1 (min. value) and T2 (max. value) of one cycle of waveform beforehand, as shown by the below dotted lines, facilitates the adjustment.
- Because TIME/DIV, T1, T2, and other setting values are different between the low-speed adjustment and high-speed adjustment, check the values by referring to "Fig.2" on Page L56-8 and "Fig.4" on Page 56-9.

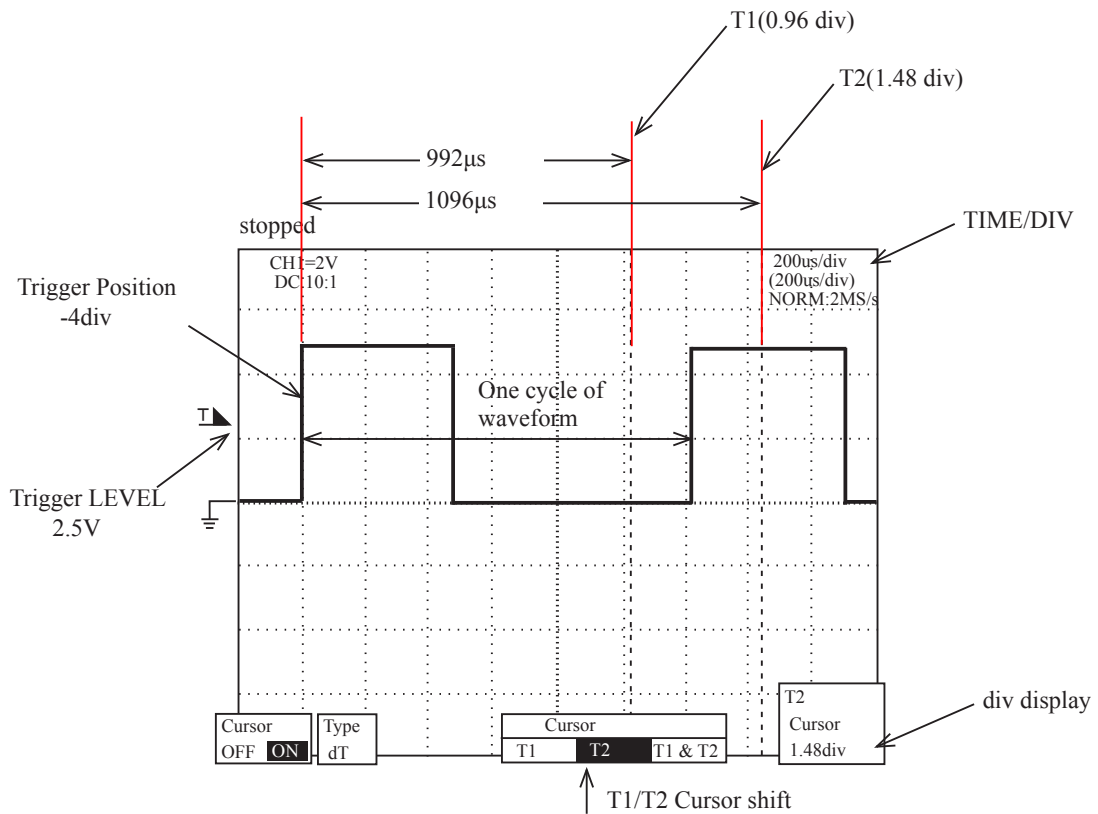

Inspection of Lens operations

Check the lens operations by using PC after assembling.

○ Check by PC

● Inspection item

1. MR encoder operations

- Activate the scanning drive of lens and check the difference in pulse no. when beginning and ending inspection.
- In case the MR head of the MR encoder and the magnetic tape are misaligned, the difference becomes larger.

2. Lens drive stop accuracy

- Check the number of overrun/underrun pulses (deviation of the stop position from the target position) per the specified lens drive amount.
- If there is no variation in mechanical operations of the focus ring driving section, the underrun tends to occur when the cam ring rotation of the MR encoder is heavy, while the overrun tends to occur when the cam ring rotation is light.

3. Lens driving time

- Check the driving time (from starting and stopping the driving) of the specified lens by using the oscilloscope.
- If there is no variation in mechanical operations of the focus ring driving section, the driving time tends to be longer when the cam ring rotation of the MR encoder is heavy, while the driving time tends to be shorter when the cam ring rotation is light.

4. Switches and lenses

- Check the ON/OFF operations of switches and the operating condition of the focus encoder and zoom encoder.

● After inspections

1. When the MR encoder operations are not up to the standard:

Make the readjustment of the electrical device. (ref. Page L56-4 ~ L56-6)

In case the pulse is not up to the standard, readjust the output waveform of the MR encoder.
(ref. Page L20)

In case the pulse meets the standard, replace the cam ring unit.

2. When the lens-servo stop accuracy is not up to the standard:

Check the output waveform of the MR encoder. If it is normal, replace the cam ring unit.

3. When the lens driving time is not up to the standard:

Readjust the driving frequency and motor control.

In case the lens driving time is not up to the standard even after the readjustment, replace the cam ring unit.

4. When switches do not work properly:

Check the wiring state of the troubled switch or replace it.



TRIPOD RING

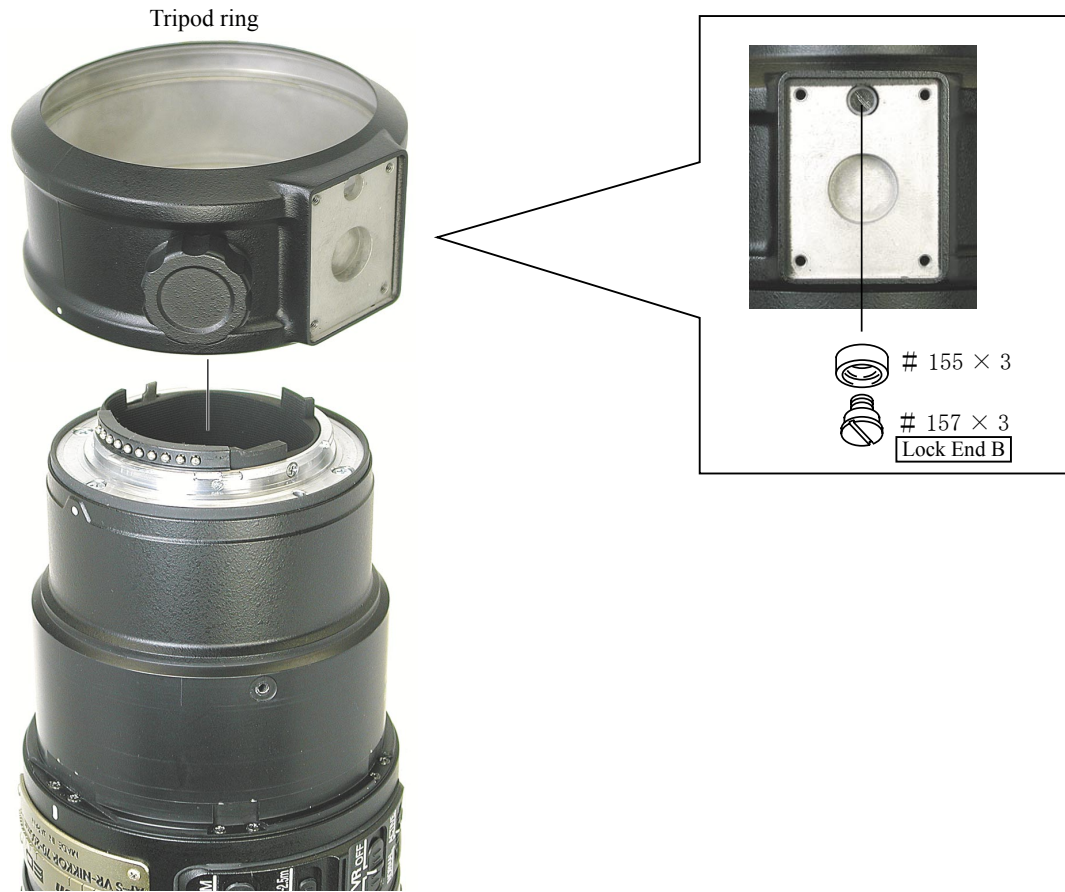

VR ADJUSTMENT

When performing the VR adjustment, please refer to the [Instruction Manual] attached to the VR lens adjustment equipment (J15380).

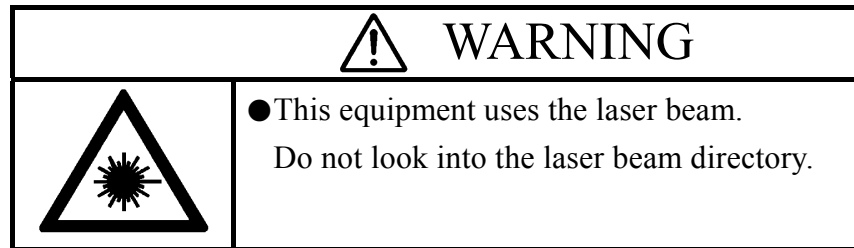

Preparation for the VR adjustment

- ① Set up the VR lens adjustment equipment (J15380) as shown in Figure below.
- ② Connect the personal computer to the equipment and run the personal computer.
- ③ Mount the lens on the equipment. Set the focus ring to the infinity position and the zoom ring to TELE side.
Please refer to the next page for the procedure to mount the lens.

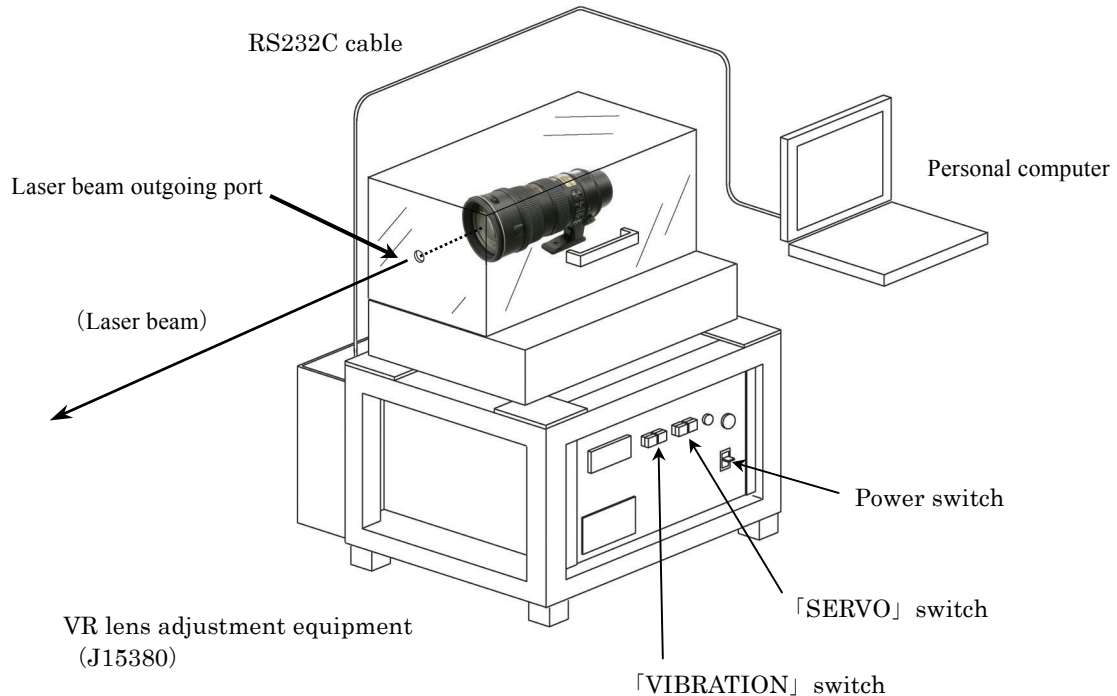

Notes: The distance from the laser beam outgoing port to the radiation face should be about 5m apart.
Do not intercept the optical path of the laser beam.

Procedure to mount the lens

- 1 . Attach the lens to the equipment and move the lens retainer stand in the direction of the arrow.

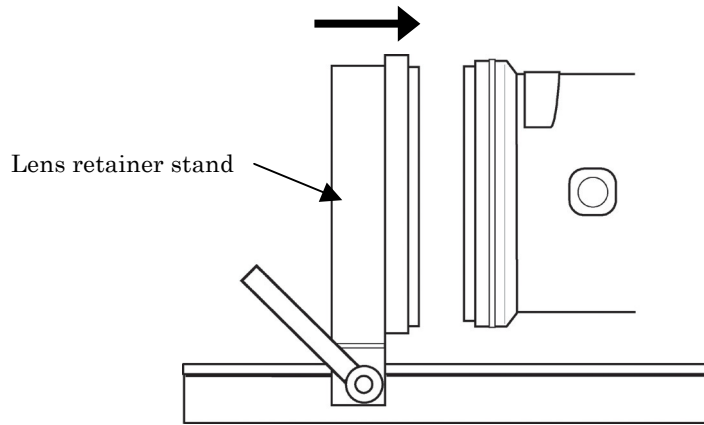

- 2 . Move the lens retainer stand to the position shown in Figure below and fix it by tightening the clamp.

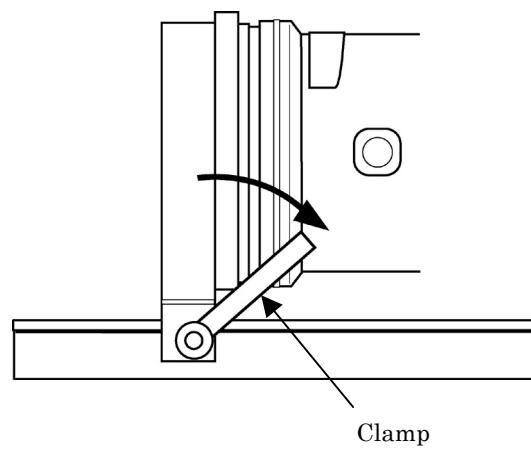

- ④ Turn on the VR lens adjustment equipment (J15380) and run the adjustment software.
- ⑤ Move the cursor to [AF-S VR 70-200/2.8G] in the Lens Selection window and click it.

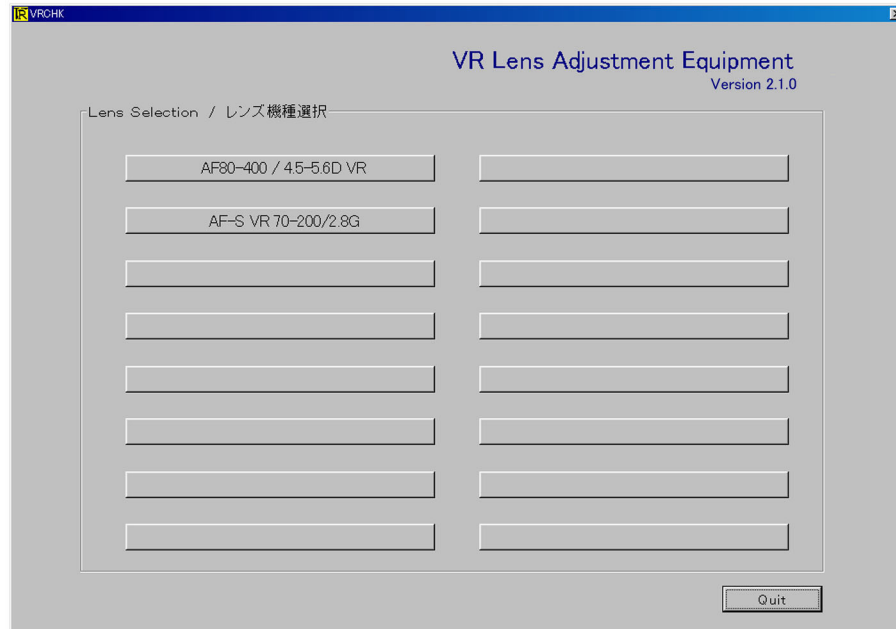

- ※If the below message appears, set the zoom ring again by referring to the pre-page [Procedure to mount the lens] and click the [OK] button.
The focus ring is automatically set.

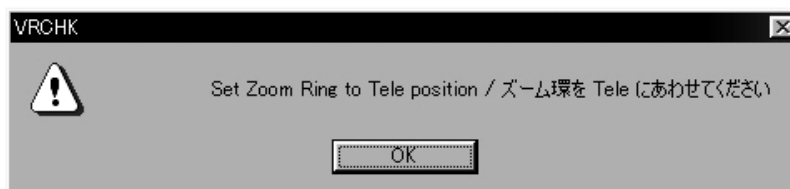

Notes : Do not change the lens settings (zoom ring) until the adjustment is finished and it goes back to the Lens Selection window.

If the setting position changes in the middle of the adjustment, the correct adjustment value cannot be obtained.

VIBRATION REDUCTION MODE SW INSPECTION

- ① Move the cursor to a box in front of the [VR Mode Switch Inspection] and click to mark the check marking.
- ② Move the cursor to the Execute button and click it.

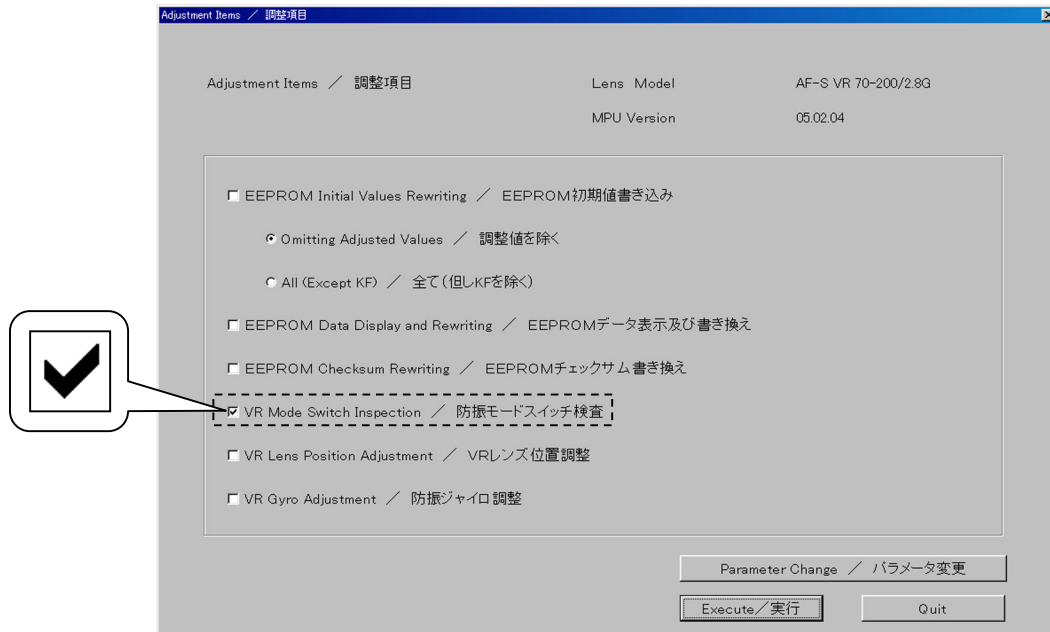

- ③ VR Mode Switch Inspection window is shown.

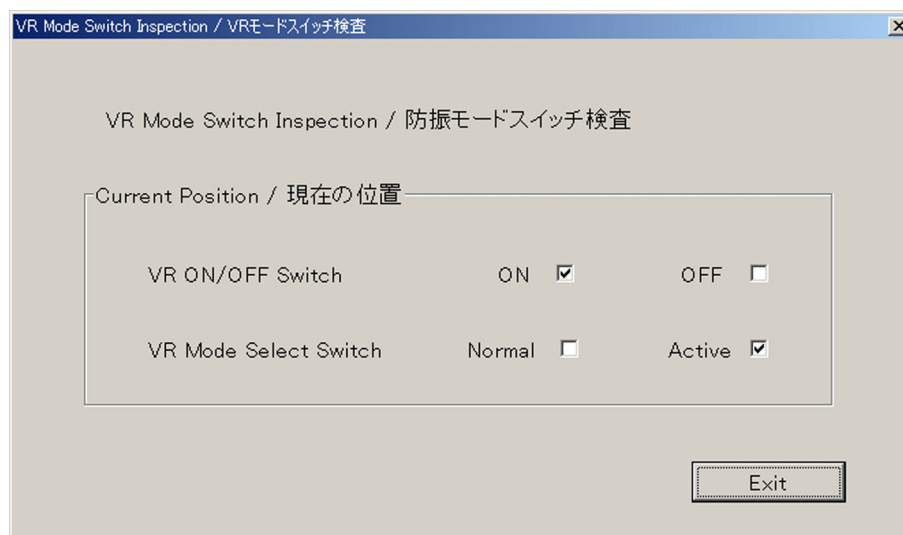

④ The position of VR mode switch is indicated.

By turning the VR mode switch, the current position is shown in the real time.

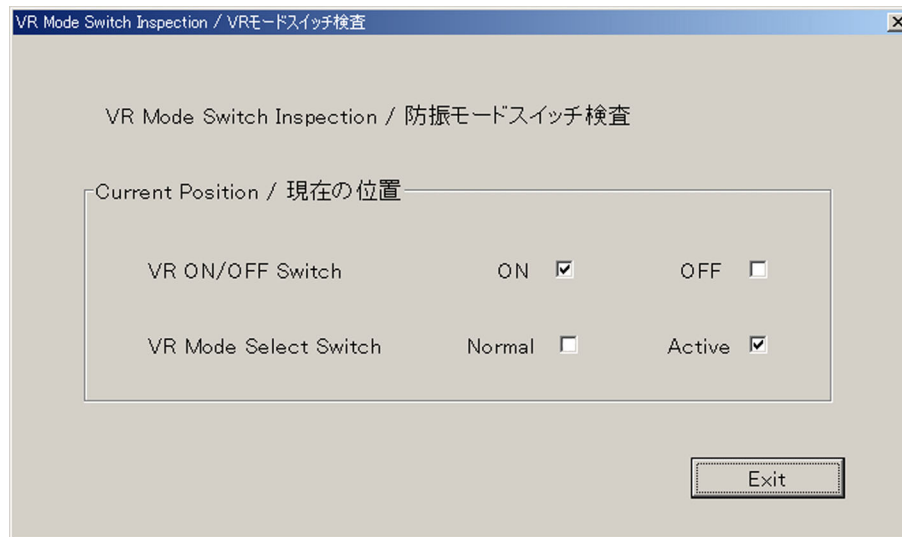

VR mode switch



⑤ When finishing the VR mode switch, move the cursor to the [Exit] button and click it to evacuate from the inspection window.

VR LENS POSITION ADJUSTMENT

- ① Move the cursor to a box in front of the [VR Lens Position Adjustment] and click it to mark the check marking.
- ② Move the cursor to the Execute button and click it.

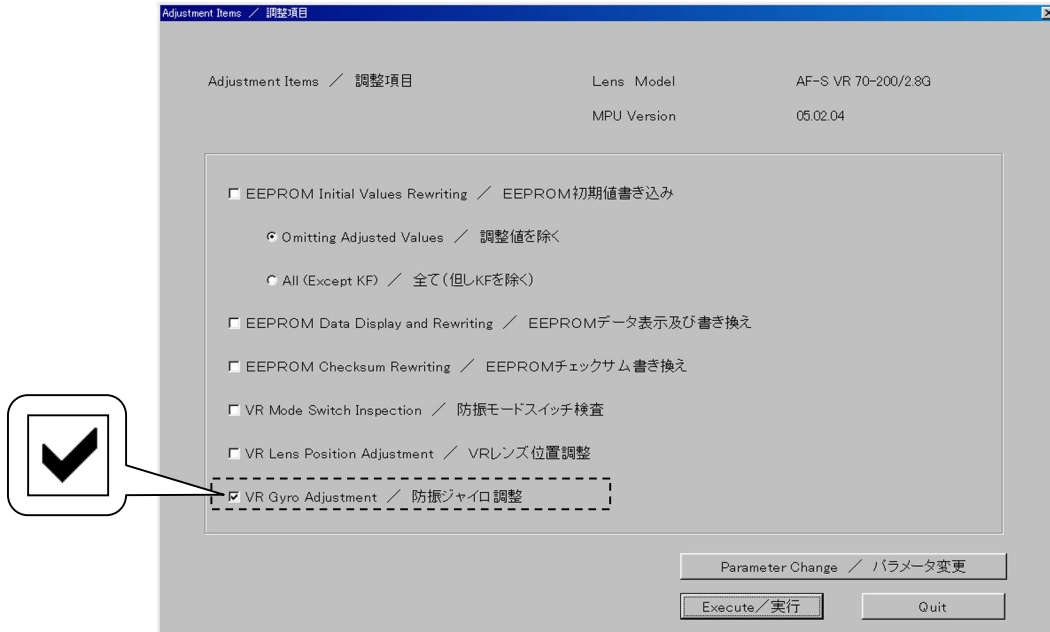

- ③ The message like a picture on the left is shown. Set the VR mode switch of the lens to ON (Full or Release), and then move the cursor to the OK button and click it.

• **VCM Polarity Adjustment (Controlled automatically)**

Detect the polarity of the VCM (Voice Coil Motor) and write it in EEPROM as the compensation value.

In-between times, the message to confirm the lens position of angle (0 or 90degrees) appears.

So, set the lens to the position and click the [OK] button.

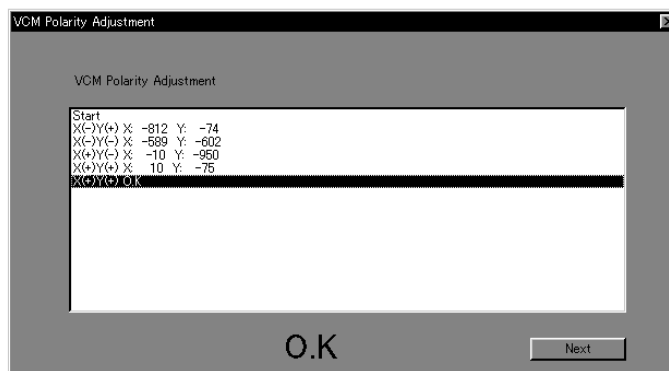

When [OK] is shown on the window, move the cursor to the Next button and click it.

• **Gamma and Shift Adjustment (Controlled automatically)**

Adjust the inclination and control center position on the basis of the position sensor output in the VR unit.

In-between times, the message to confirm the lens position of angle (0 or 90degrees) appears.

So, set the lens to the position and click the [OK] button.

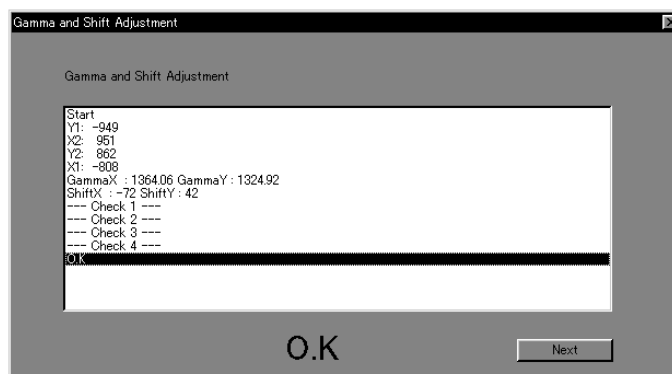

When [OK] is shown on the window, move the cursor to the Next button and click it.

• **Electromagnetic Lock Center Position Adjustment (Controlled automatically)**

Adjust the electromagnetic lock center position.

In-between times, the message to confirm the lens position of angle (0 or 90degrees) appears.

So, set the lens to the position and click the [OK] button.

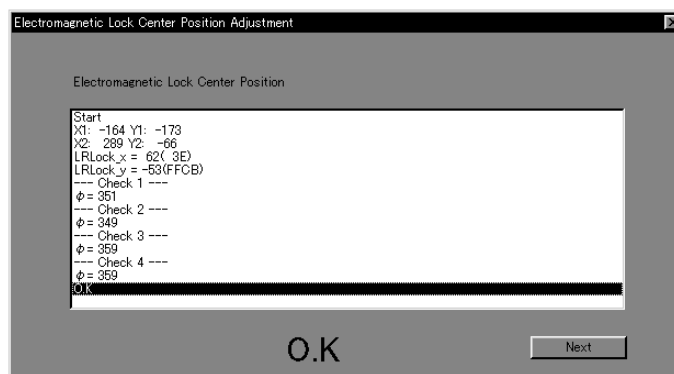

When [OK] is shown on the window, move the cursor to the Next button and click it.

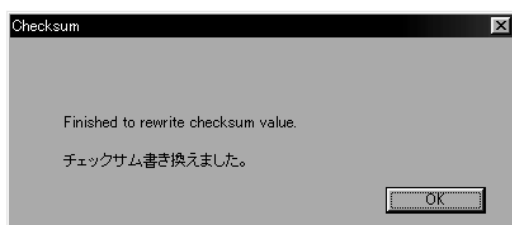

- When the message that says rewriting the checksum

is finished is shown, click the [OK] button.

Then set the VR mode to OFF according to the message and click the OK button to evacuate from the adjustment window.

Notes :

If [NG] is shown in the middle of the adjustment, click the Next button. This makes it possible to evacuate from the inspection mode and to go back to the Lens Selection window after rewriting the checksum value. Then adjust it again.

If it becomes be [NG] even performing the adjustment a few times, the VR unit, the gyro PCB or the main FPC might be defective.

VR GYRO ADJUSTMENT

① Move the cursor to a box in front of [VR Gyro Adjustment] and click it to mark the check marking.

② Move the cursor to the Execute button and click it.

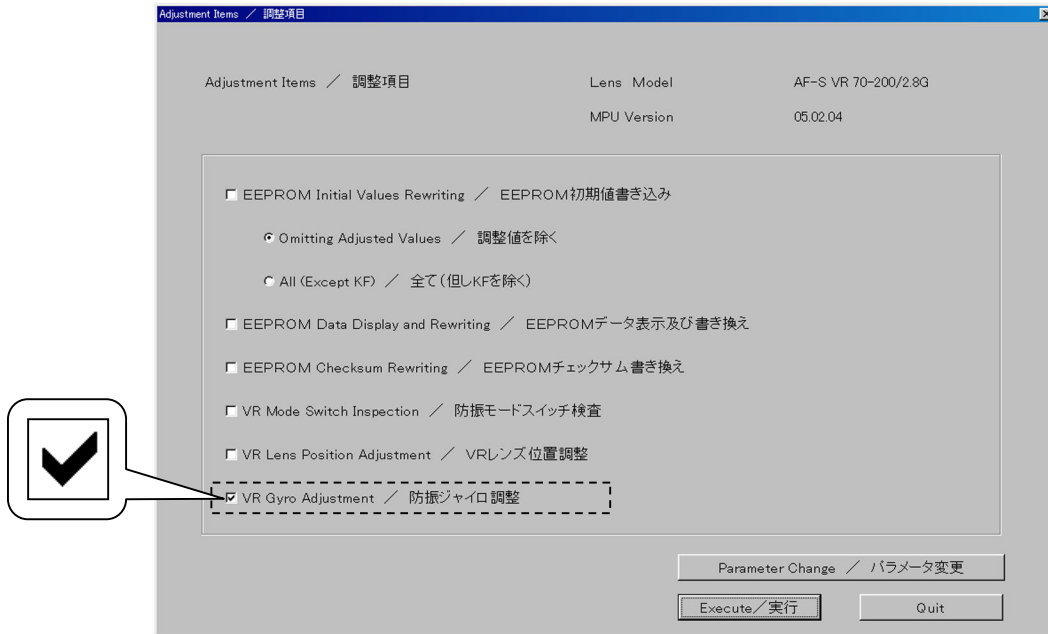

③ The message like a picture on the left is shown. Set it to the Telephoto settings.

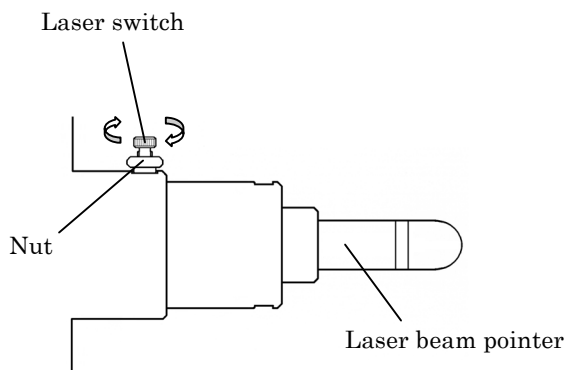

④ Loosen the nut of the laser switch of the VR lens adjustment equipment (J15380) and rotate the screw in an arrow direction to give the laser.

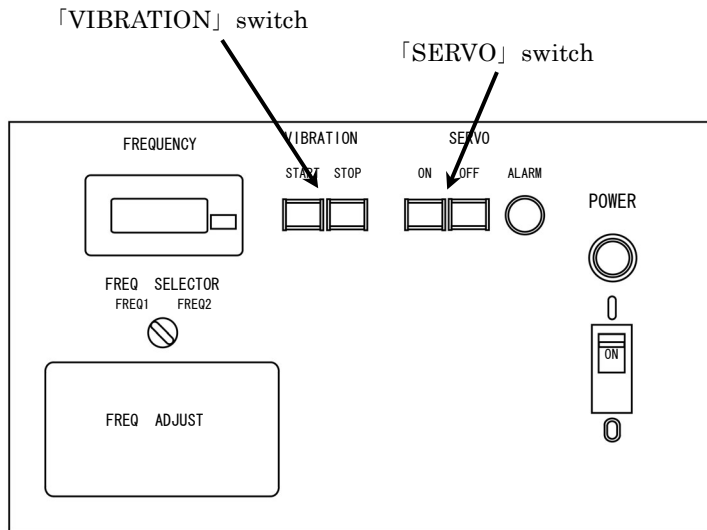

⑤ Press the SERVO [ON] button and the VIBRATION [START] button of the VR lens adjustment equipment (J15380).

⑥ With the equipment starts to vibrate, measure the length of the vibration width α of the laser beam.

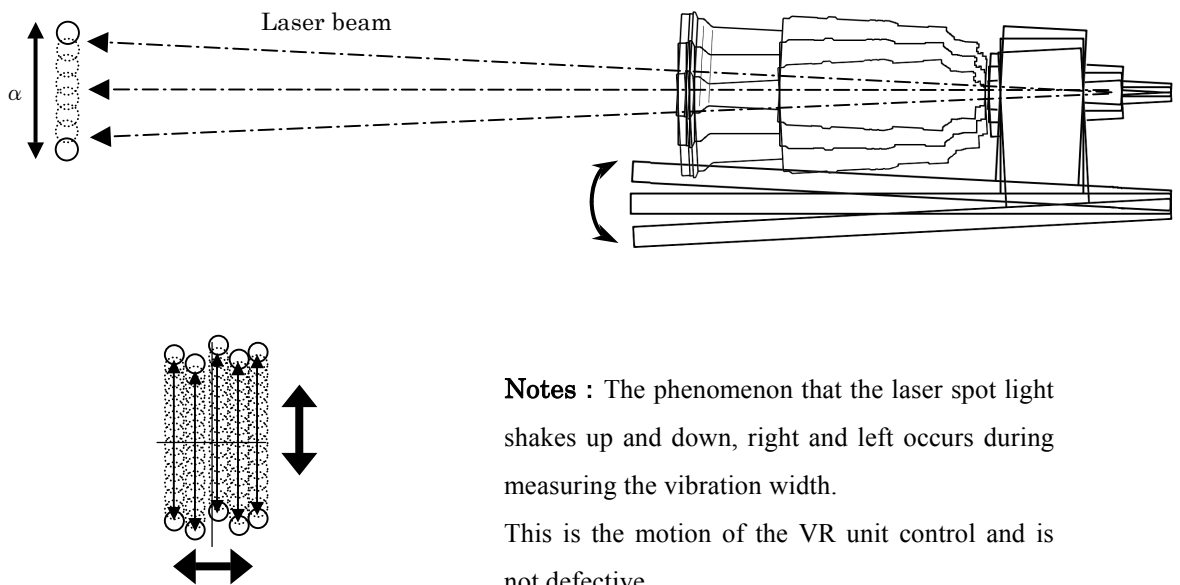

Notes : The phenomenon that the laser spot light shakes up and down, right and left occurs during measuring the vibration width.
This is the motion of the VR unit control and is not defective.



⑦ Move the cursor to the Next button in the message box on the screen and click it.

Vibration reduction function starts to perform and the vibration width of the laser beam becomes be narrow.

• Angle Difference Adjustment

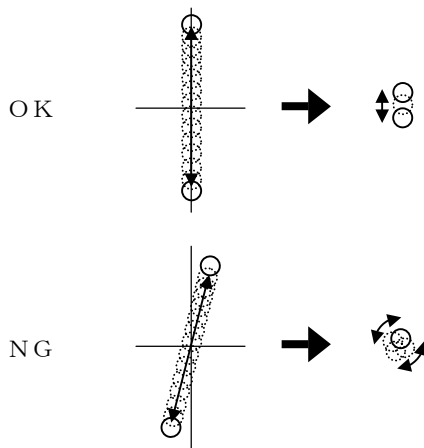

If there is angle difference, the laser beam source becomes be whether if it rotates round even performing the Gyro Gain Adjustment.

If it is possible to confirm the angle difference, adjust it by the buttons for the angle difference adjustment.

Notes : After operating the adjustment button, wait for a few seconds until a vibration motion is stabilized.

Buttons for [Gyro Gain] Adjustment

Buttons for [Angle Difference] Adjustment

• Gyro Gain Adjustment

Adjust the vibration width by the button for Gyro Gain Adjustment so that the length of the vibration width becomes be less than 1/5 of the measured laser vibration width α .

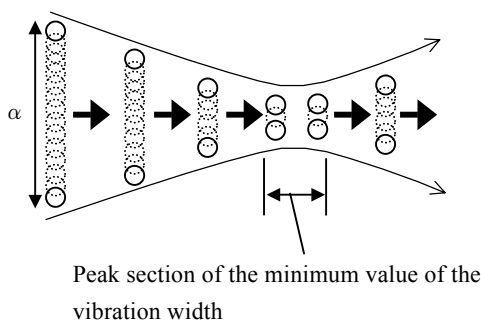

Standard: Less than 1/5 of the vibration width α

Notes : The laser beam vibrates widely again after it passes the peak section of the minimum value.

《Reference》

- The laser spot beam is irradiated about 10mm in diameter at 5 m ahead.

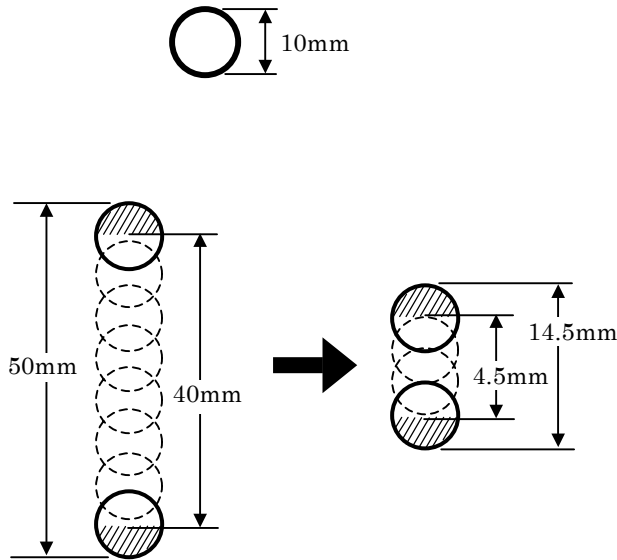

① To adjust the vibration width at the center of the laser spot beam, measure the whole vibration width first.

② Subtract the radius of the laser spot (oblique lined part) from the top and bottom of the measured vibration width.

Example)

When the whole vibration width is [About 42.5mm], the center vibration width becomes be $50 - (5 + 5) = 40\text{mm}$.

Standard after the gyro gain adjustment

$40 \times 1/5 = 8\text{mm}$ (Center vibration width)

Whole vibration width becomes be

$4.5 + (5+5) = 14.5\text{mm}$.

- How to obtain the minimum value of the vibration width

- ① Measure the vibration width while changing the adjustment value that is set every 0.02Step as shown below.
- ② The peak section of the minimum vibration width can be obtained by the actual measured value.
- ③ Take the center of the peak section as the adjustment value.



Gyro Gain Adjustment Value	Vibration width Actual measured value
• _____	•
• _____	•
0.9 0	1 6.5 mm
0.9 2	1 6.0 mm
0.9 4	1 5.5 mm
0.9 6	1 5.0 mm
0.9 8	1 4.5 mm
1.0 0	1 4.5 mm
1.0 2	1 4.5 mm
1.0 4	1 5.0 mm
1.0 6	1 5.5 mm
1.0 8	1 6.0 mm
1.1 0	1 6.5 mm
• _____	•
• _____	•

} Peak section of the minimum value of the vibration width

Notes : When measuring the vibration width, read it in unit of 0.5mm.

- Rotate the lens 90 ° in an arrow direction and then adjust the angle difference and the gyro gain.

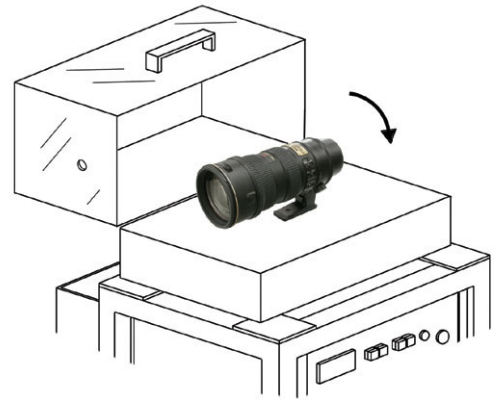

Notes : When adjusting the lens at 90 ° position, adjust it by the buttons for the adjustment at 90 ° position as shown in Figure below.

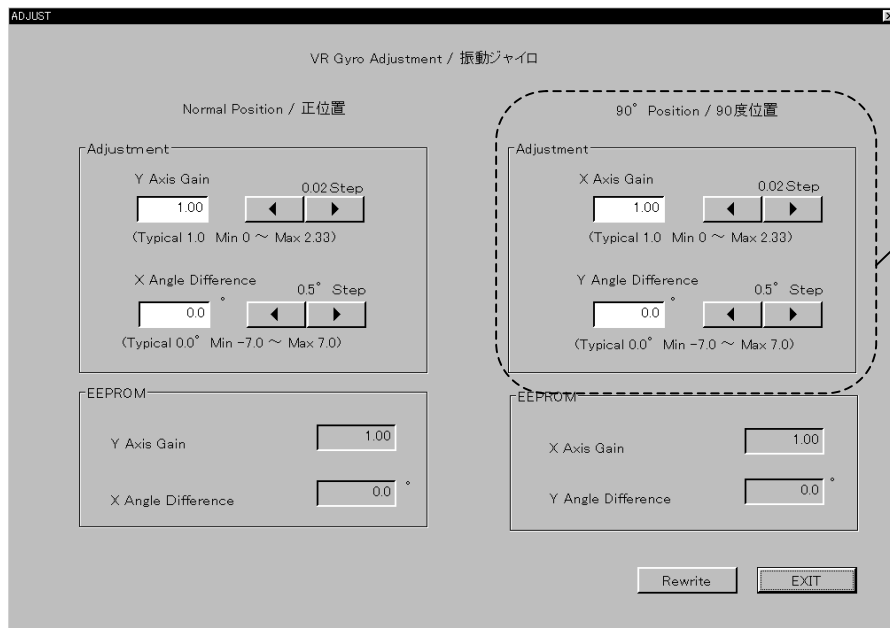

Buttons for adjustment at 90 ° position

- After the adjustment, click the [Rewrite] button to write the adjustment value in EEPROM in the lens.
- Then, click the [EXIT] button to evacuate from the adjustment mode.

Notes : If clicking [EXIT] button after not clicking the [Rewrite] button, the adjustment value is not stored and the adjustment is not influenced.

- Click the [Quit] button at the Adjustment Items window to go back to the Lens Selection window.

Notes : Do not remove the lens or turn OFF the VR lens adjustment equipment until it goes back to the Lens Selection window. The trouble that the adjustment value is not stored correctly, etc. occurs since the communication is cut off.

STANDARD TO JUDGE THE VR PERFORMANCE

Please refer to the following chart before performing the VR adjustment for the product of which VR is defective with the equipment.

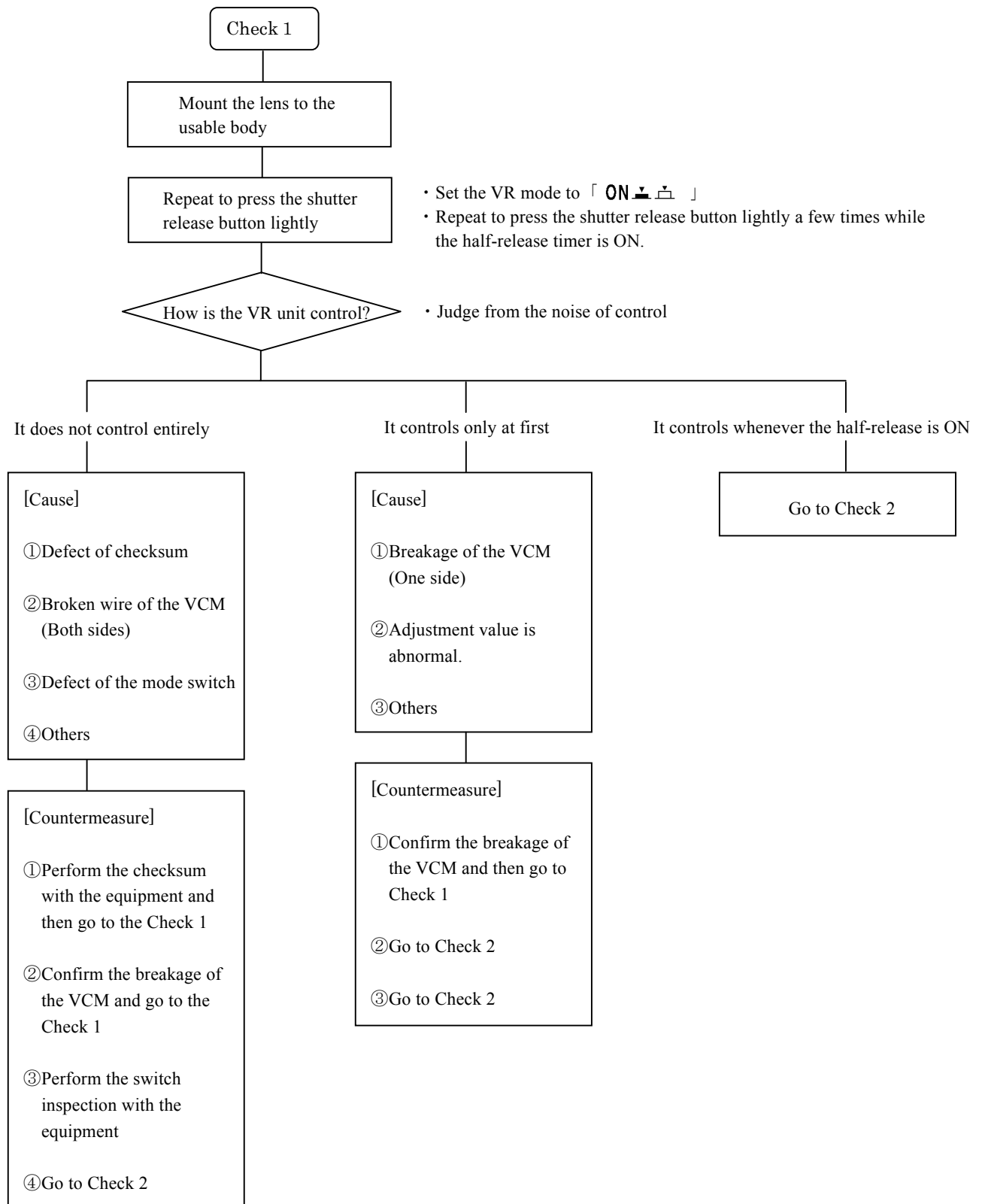

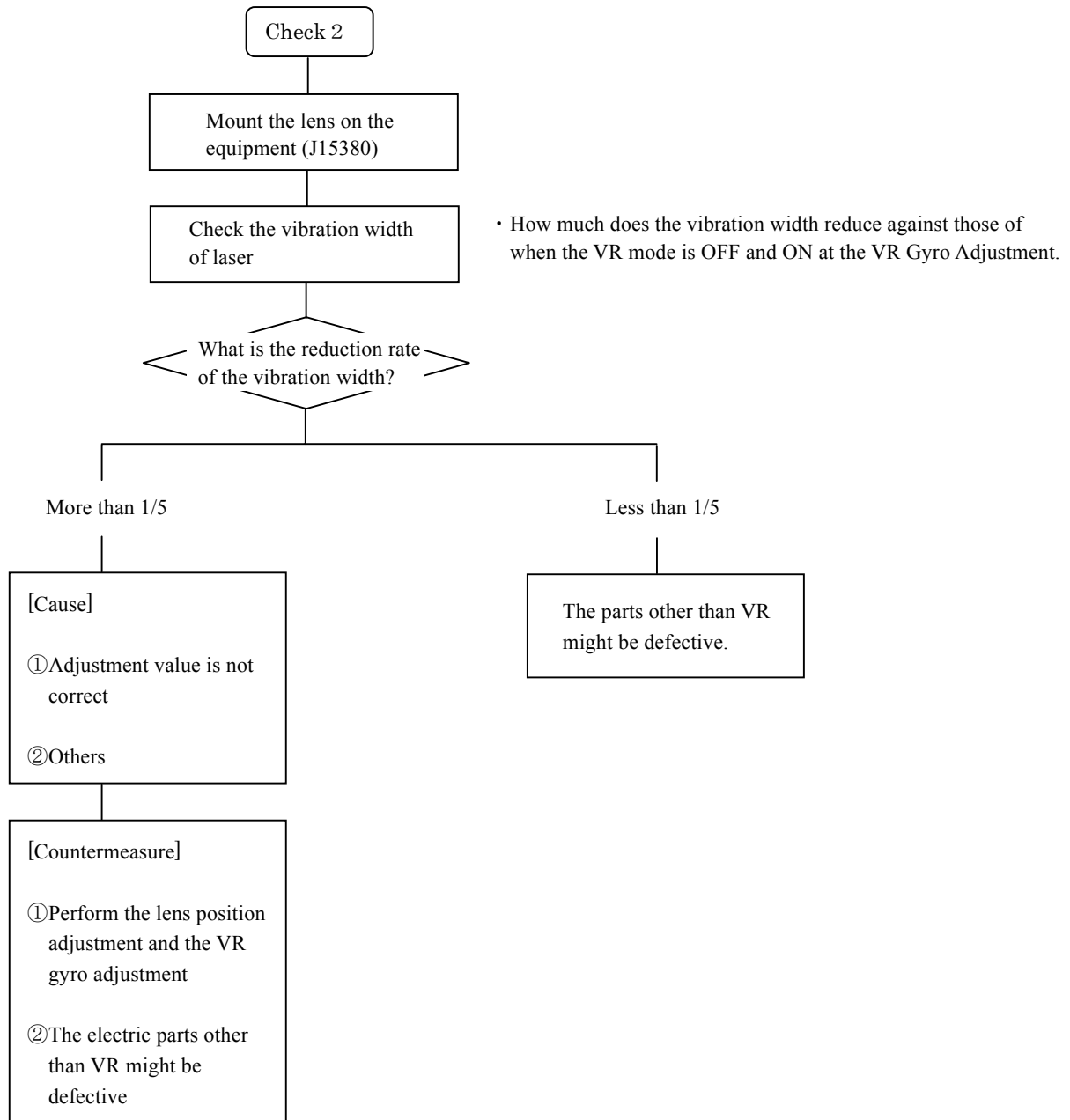

Go on the next page [Check 2]

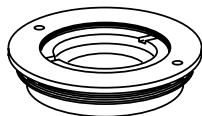
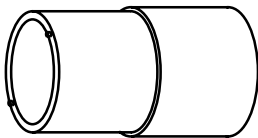
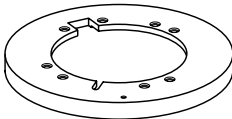
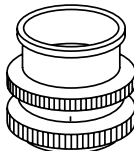

Tools

★ : New tool

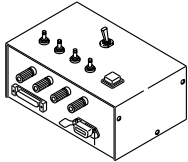
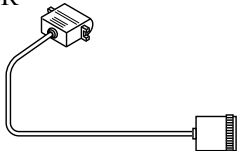
RJ No.	Name	Note
G92KA	FLOIL G92KA	
I-40	GREASE I-40	
EDB0011	SCREW LOCK 1401C	
L-241	LOCK END	
★ J11292	MIRROR TOOL 	
★ J11293	WRENCH 	
★ J15397	ZOOM ENCODER BRUSH POSITIONING TOOL 	
J19002	BACK FOCUS COLLIMATER LT-500S	
J18028	LENS ADAPTER FOR FOCUS TESTER 	
★ J18342	AF-S ZOOM LENS(NEW)INSPECTION AND ADJUSTMENT SOFTWARE 	
J15306 or J15306-1	AF-I COMMUNICATION BOX 	
J15307	AF-I COMMUNICATION ADPAPTER 	
	PERSONAL COMPUTER	
	POWER SUPPLY	
	OSCILLOSCOP	
J15380A	VR LENS ADJUSTMENT EQUIPMENT	AC100V
J15380B	VR LENS ADJUSTMENT EQUIPMENT	AC200V
J15380-5	VR LENS INSPECTION AND ADJUSTMENT SOFTWARE	IBM 3.5inch
J15380-2	STAND FOR INCLINATION ADJUSTMENT	INCLINATION ADJUSTMENT FOR 1G

★ : New tool

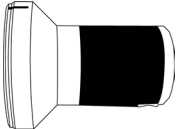
R J No.	名 称	備 考
★ J11295	2nd LENS-G ASSEMBLING TOOL 	
★ J11296	G4 RETAINER RING ASSEMBLING TOOL 	

外觀図 Sketch drawings

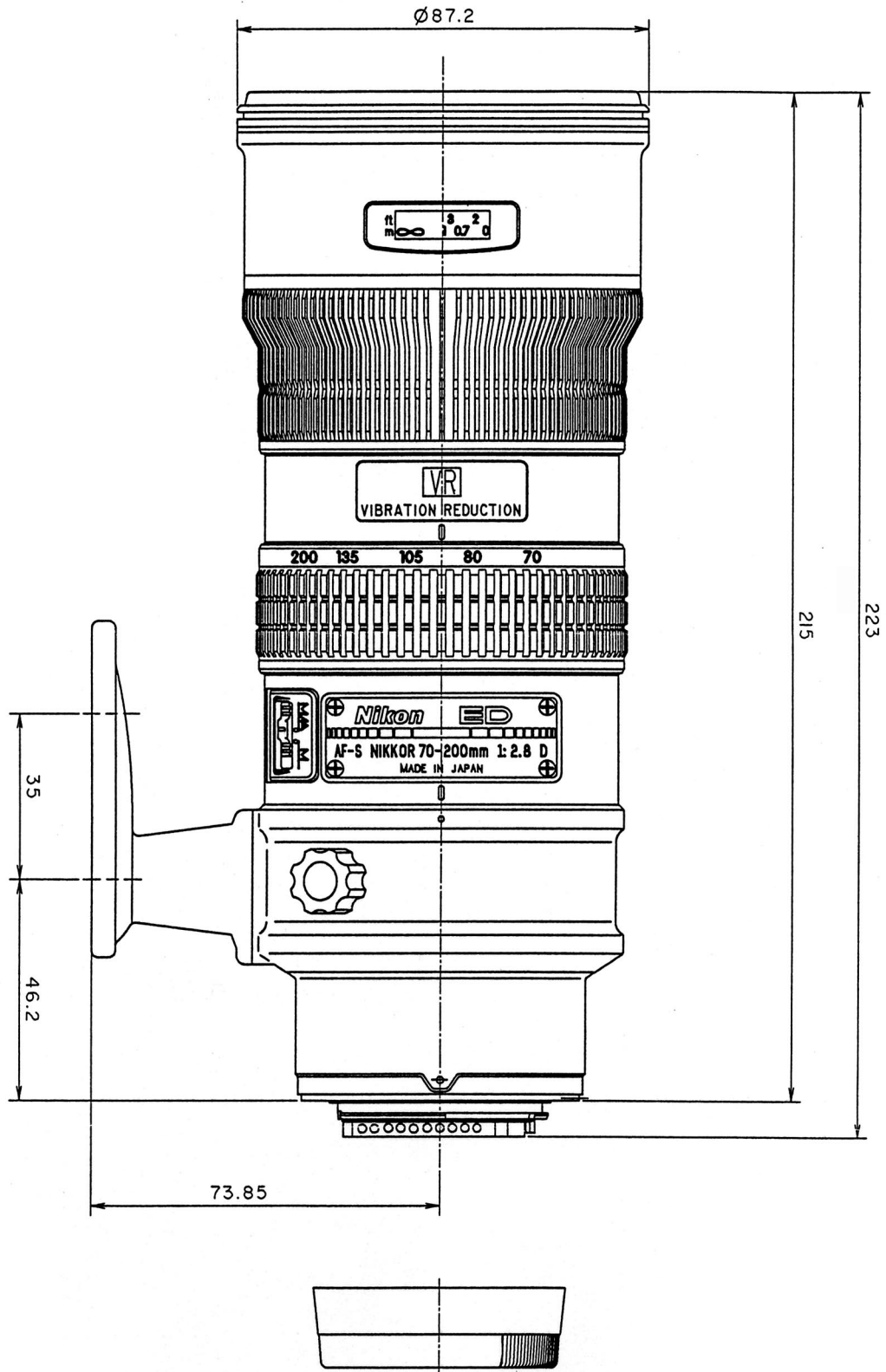

組立図 Structure of the Lens

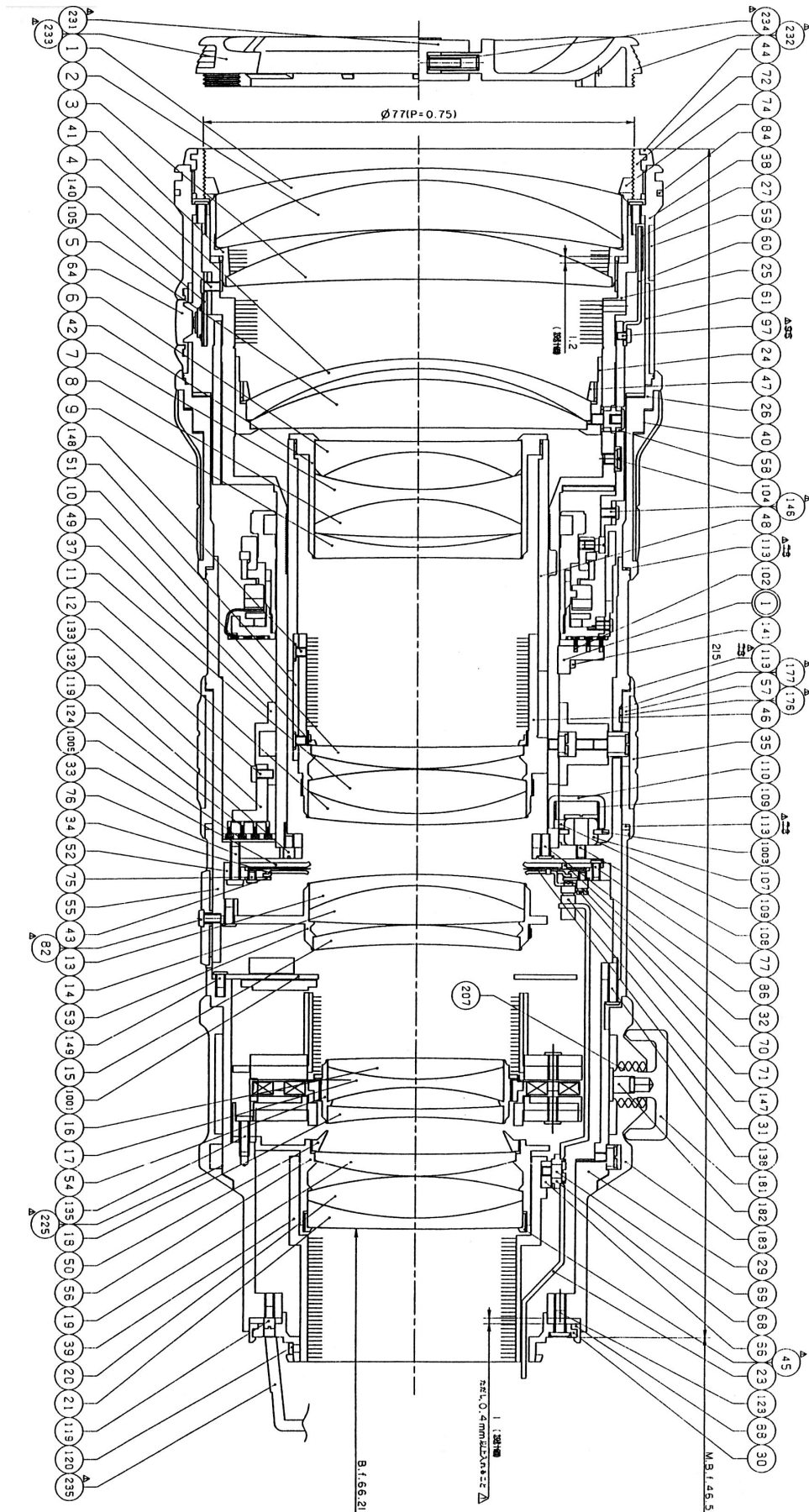

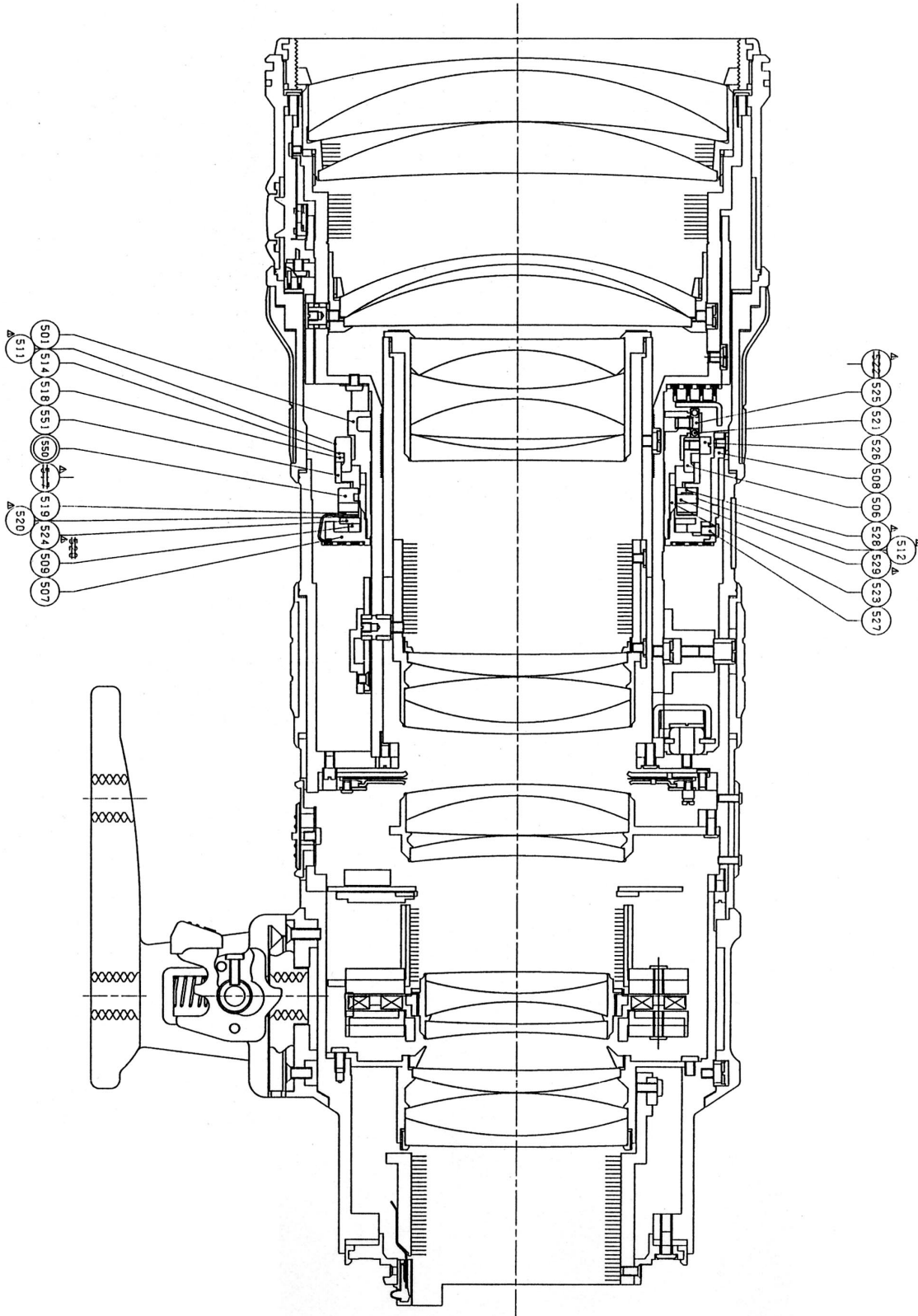

実体配線図 WIRING DIAGRAM

