



US005367354A

United States Patent [19]

[11] Patent Number: **5,367,354**

Kawasaki et al.

[45] Date of Patent: **Nov. 22, 1994**

- [54] **MOTOR DRIVEN LENS AND CAMERA SYSTEM**
- [75] Inventors: **Masahiro Kawasaki; Hiroyuki Takahashi; Yoshinari Tanimura**, all of Tokyo, Japan
- [73] Assignee: **Asahi Kogaku Kogyo Kabushiki Kaisha**, Tokyo, Japan

5,036,349	7/1991	Suzuki et al.	354/195.12
5,043,754	8/1991	Aihara et al.	354/286
5,063,402	11/1991	Shimada et al.	354/400
5,065,172	11/1991	Ogawa	354/195.1
5,065,175	11/1991	Suzuki et al.	354/400
5,066,968	11/1991	Suzuki et al.	354/400
5,066,969	11/1991	Kawasaki	354/402
5,093,680	3/1992	Suzuki et al.	354/400

- [21] Appl. No.: **886,701**
 - [22] Filed: **May 21, 1992**
 - [30] **Foreign Application Priority Data**
- | | | | |
|---------------|------|-------|----------|
| May 21, 1991 | [JP] | Japan | 3-218146 |
| Nov. 29, 1991 | [JP] | Japan | 3-342123 |

FOREIGN PATENT DOCUMENTS

0357056	3/1990	European Pat. Off.	.
0360294	3/1990	European Pat. Off.	.
0361355	4/1990	European Pat. Off.	.
0361513	4/1990	European Pat. Off.	.
3126779	5/1982	Germany	.
3611784	1/1987	Germany	.
3921618	1/1990	Germany	.

(List continued on next page.)

- [51] Int. Cl.⁵ **G03B 13/00**
- [52] U.S. Cl. **354/400; 354/195.12**
- [58] Field of Search **354/400-409, 354/195.1-195.12, 173.1, 173.11**

OTHER PUBLICATIONS

Minolta Techno Report, "Lens Drive Control With A Soft Governor", 1986, with English Translation.

- [56] **References Cited**

U.S. PATENT DOCUMENTS

4,083,057	4/1978	Quinn	354/400
4,145,732	3/1979	Pandres, Jr.	354/195.12
4,156,933	5/1979	Pandres, Jr.	354/195.12
4,166,675	9/1979	Kanno	354/400
4,269,489	5/1981	Takimoto et al.	354/268
4,477,167	10/1984	Ishikawa et al.	354/400
4,509,842	4/1985	Taniguchi et al.	354/402
4,550,992	11/1985	Ohtsuka et al.	354/173.11
4,662,736	5/1987	Taniguchi et al.	354/412
4,671,640	6/1987	Akada et al.	354/402
4,719,485	1/1988	Shikaumi	354/400
4,731,629	3/1988	Aoshima et al.	354/410
4,782,355	11/1988	Sakai et al.	354/400
4,840,470	6/1989	Ohtake	354/402
4,857,951	8/1989	Nakajima et al.	354/400
4,866,468	9/1989	Himuro et al.	354/195.1
4,881,094	11/1989	Terui et al.	354/286
4,908,643	3/1990	Tamada et al.	354/400
4,924,249	5/1990	Aihara et al.	354/400
4,935,763	6/1990	Itoh et al.	354/400
4,951,075	8/1990	Tokumaru et al.	354/400
4,967,218	10/1990	Numako et al.	354/400
4,984,001	1/1991	Himuro	354/195.12

Primary Examiner—David M. Gray
Attorney, Agent, or Firm—Sandler, Greenblum & Bernstein

[57] ABSTRACT

A motor driven lens includes a movable lens group and a lens moving mechanism which hold and move the movable lens group in an optical axis direction within a predetermined movable range. The motor driven lens further includes a motor for driving the lens moving mechanism to move the movable lens group. A counter counts the time in which a movement of the movable lens group is impeded during the operation of the motor, and a control device controls an operational speed of the motor and stops the operation of the motor for a predetermined period of time in which the movement of the movable lens group is impeded, depending on the operational speed of the motor.

31 Claims, 91 Drawing Sheets

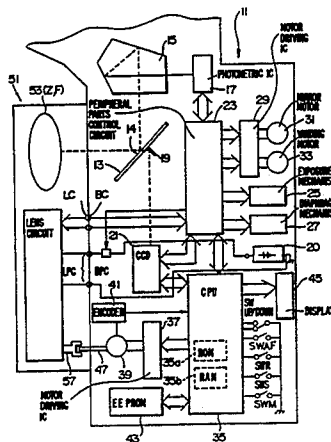

FOREIGN PATENT DOCUMENTS

53-113527	10/1978	Japan .	63-220118	9/1988	Japan .
55-52006	4/1980	Japan .	64-44429	2/1989	Japan .
58-125005	7/1983	Japan .	64-74515	3/1989	Japan .
58-202432	11/1983	Japan .	2039681	8/1980	United Kingdom .
58-223108	12/1983	Japan .	2183412	6/1987	United Kingdom .
59-204013	11/1984	Japan .	2212679	7/1989	United Kingdom .
62-133430	6/1986	Japan .	2221107	1/1990	United Kingdom .
62-133431	6/1986	Japan .	2232262	12/1990	United Kingdom .
61-252517	11/1986	Japan .	2233777	1/1991	United Kingdom .
61-292608	12/1986	Japan .	2234600	2/1991	United Kingdom .
62-118328	5/1987	Japan .	2235552	3/1991	United Kingdom .
63-11613	1/1988	Japan .	2241073	8/1991	United Kingdom .
			2241074	8/1991	United Kingdom .
			2244564	12/1991	United Kingdom .

Fig. 1

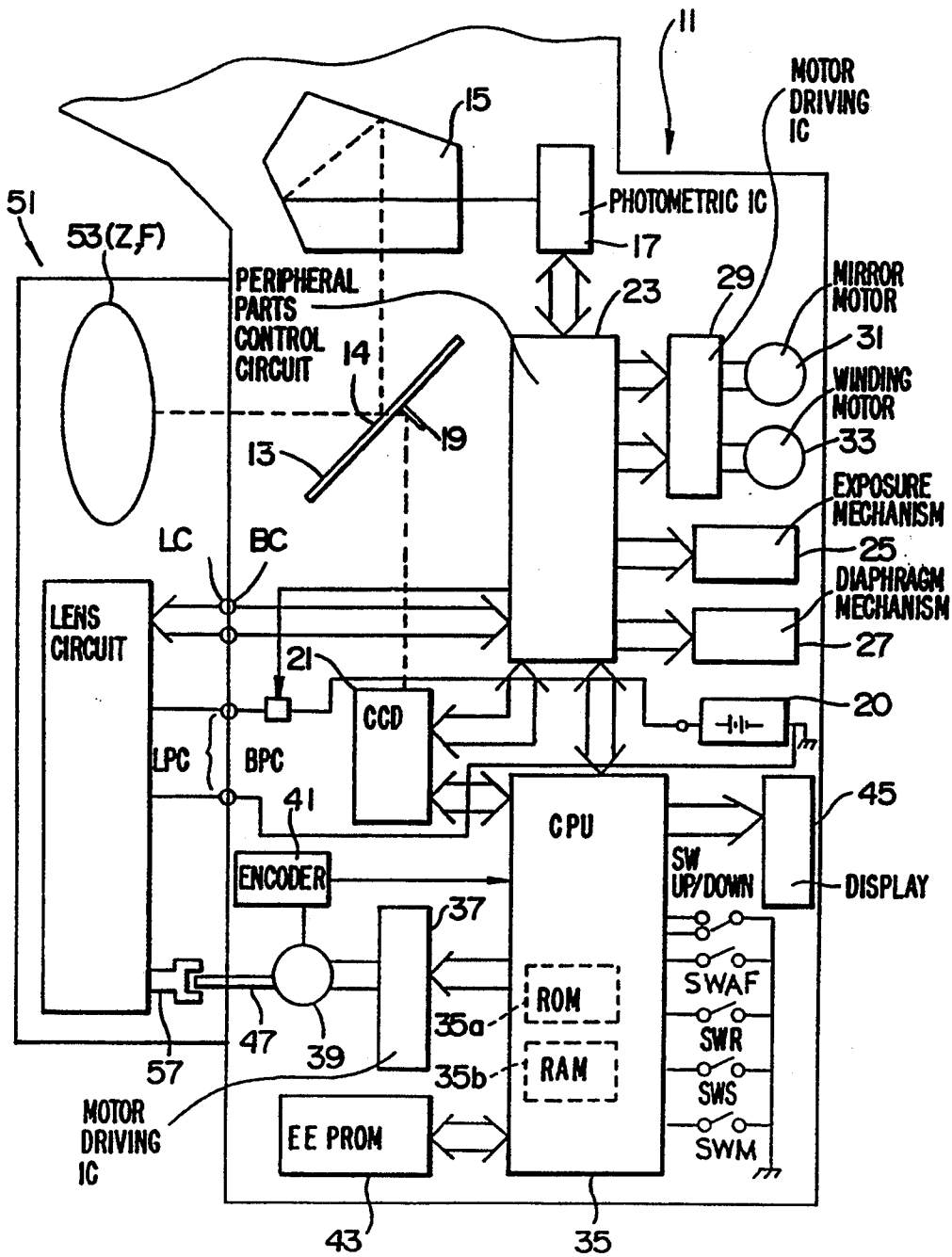
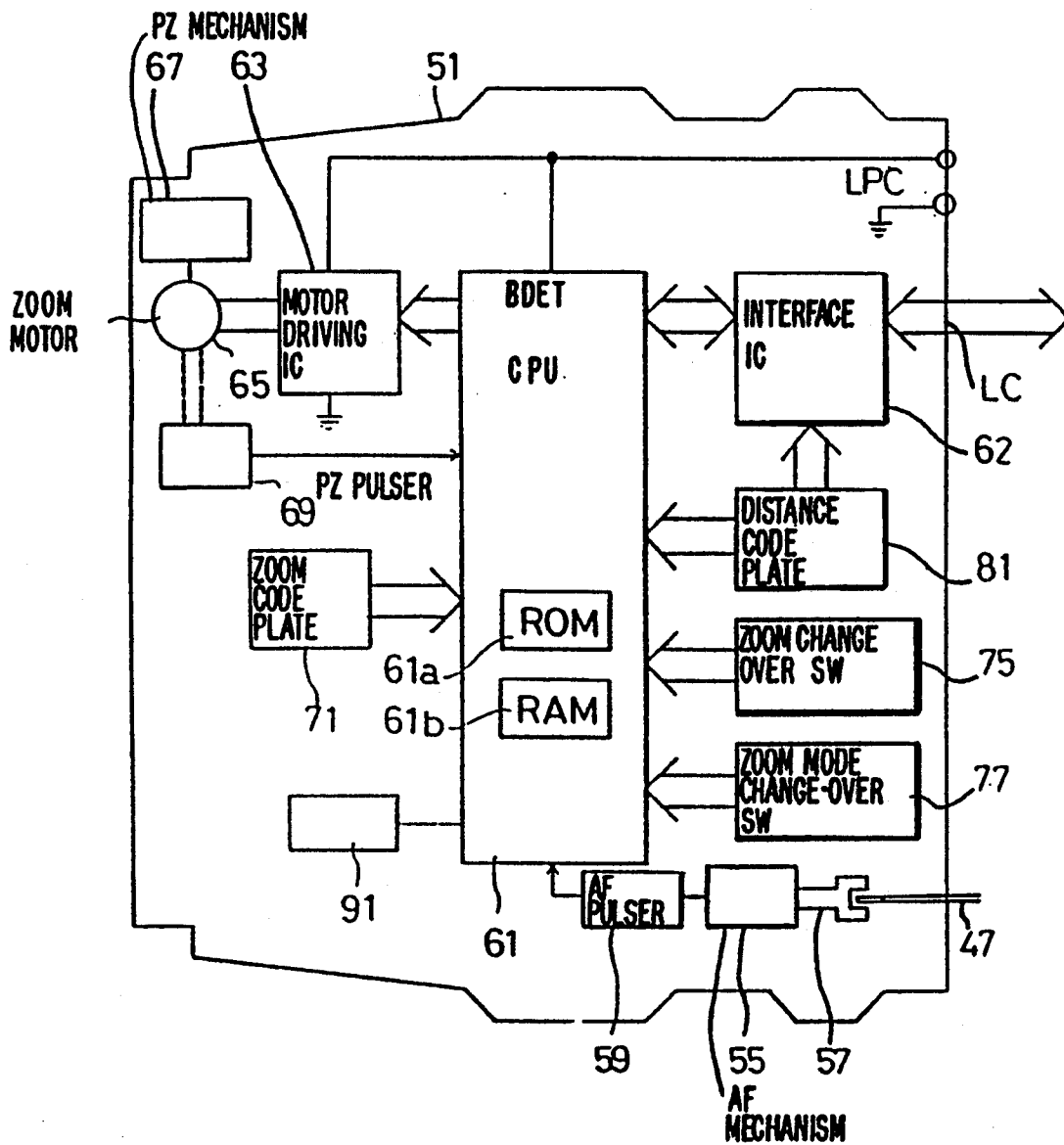

Fig. 2



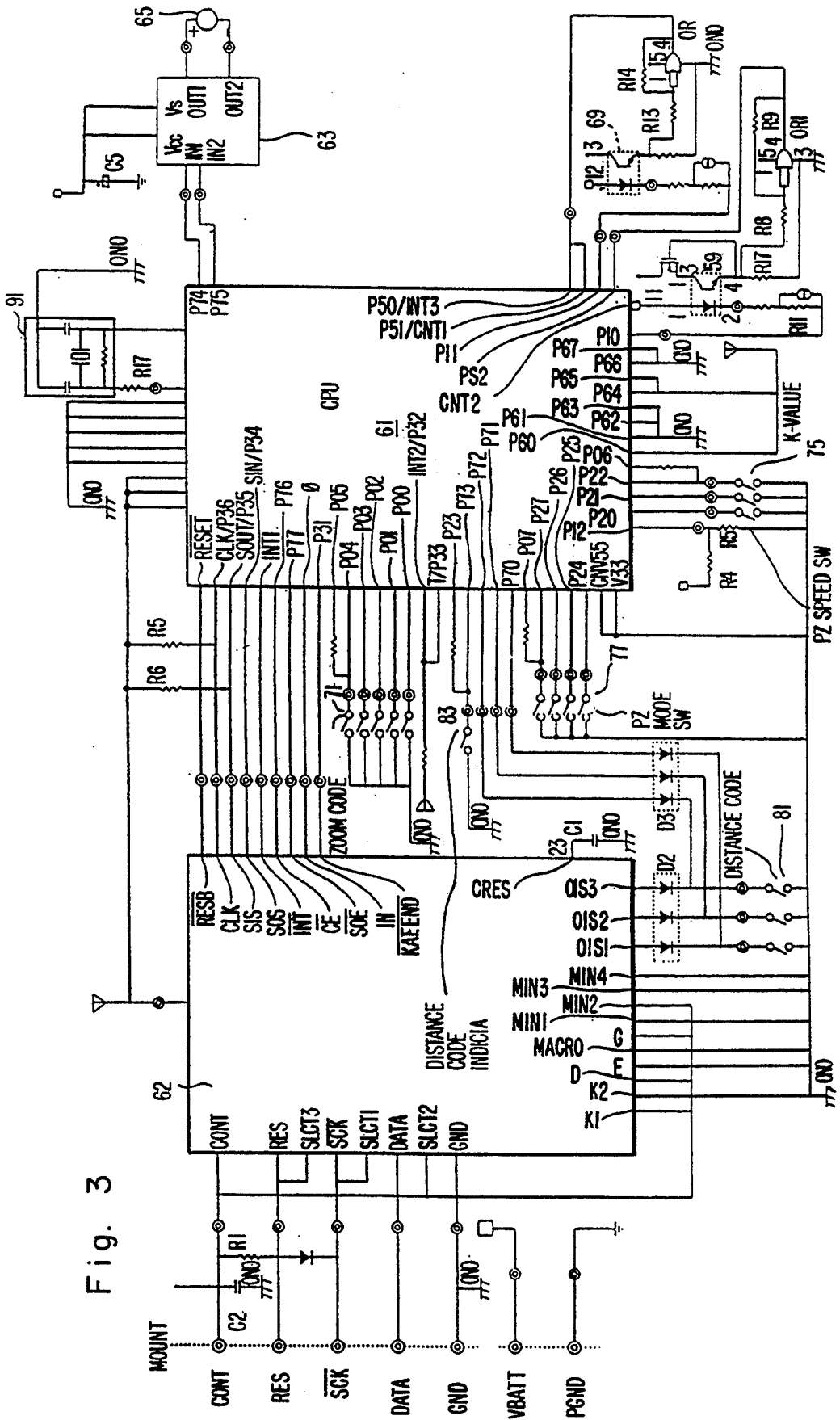

Fig. 3

Fig. 4

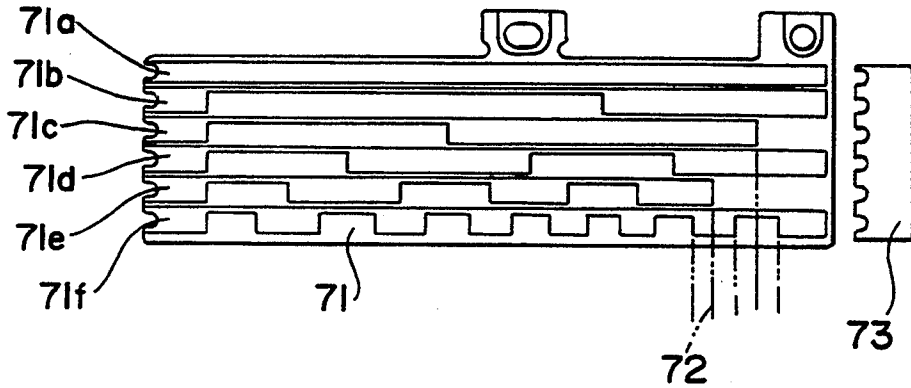

Fig. 5

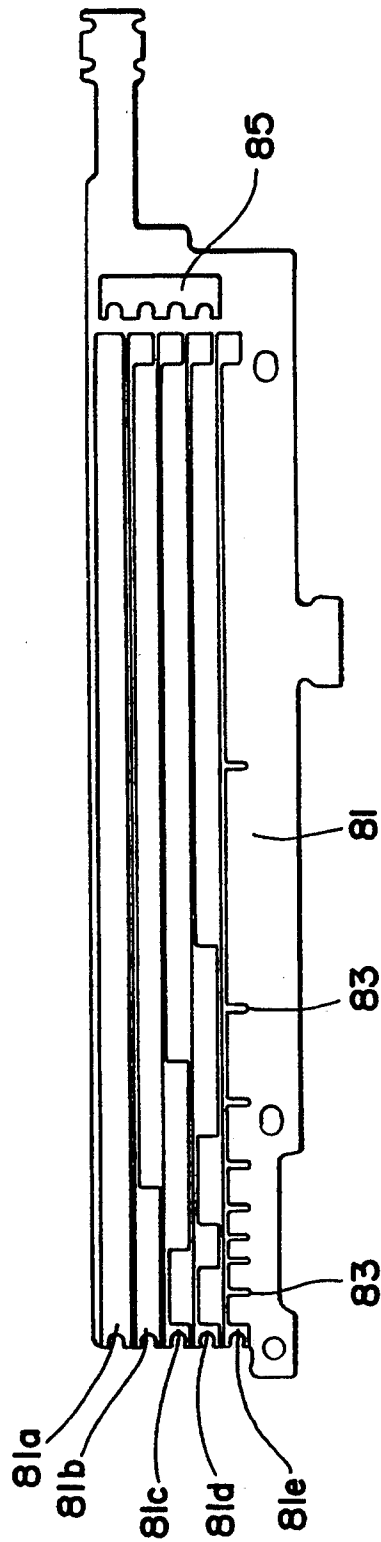

Fig. 6

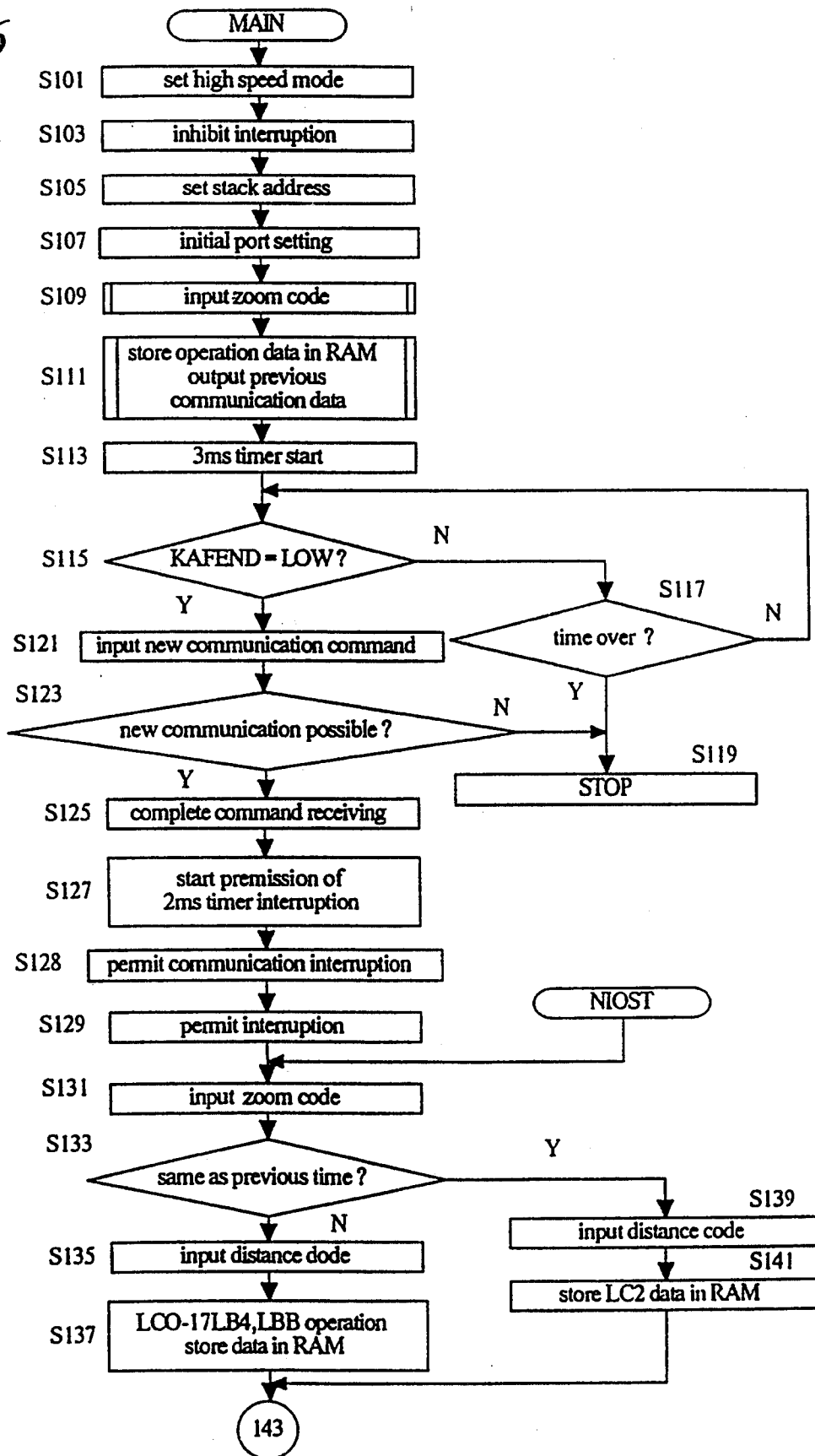

Fig. 7

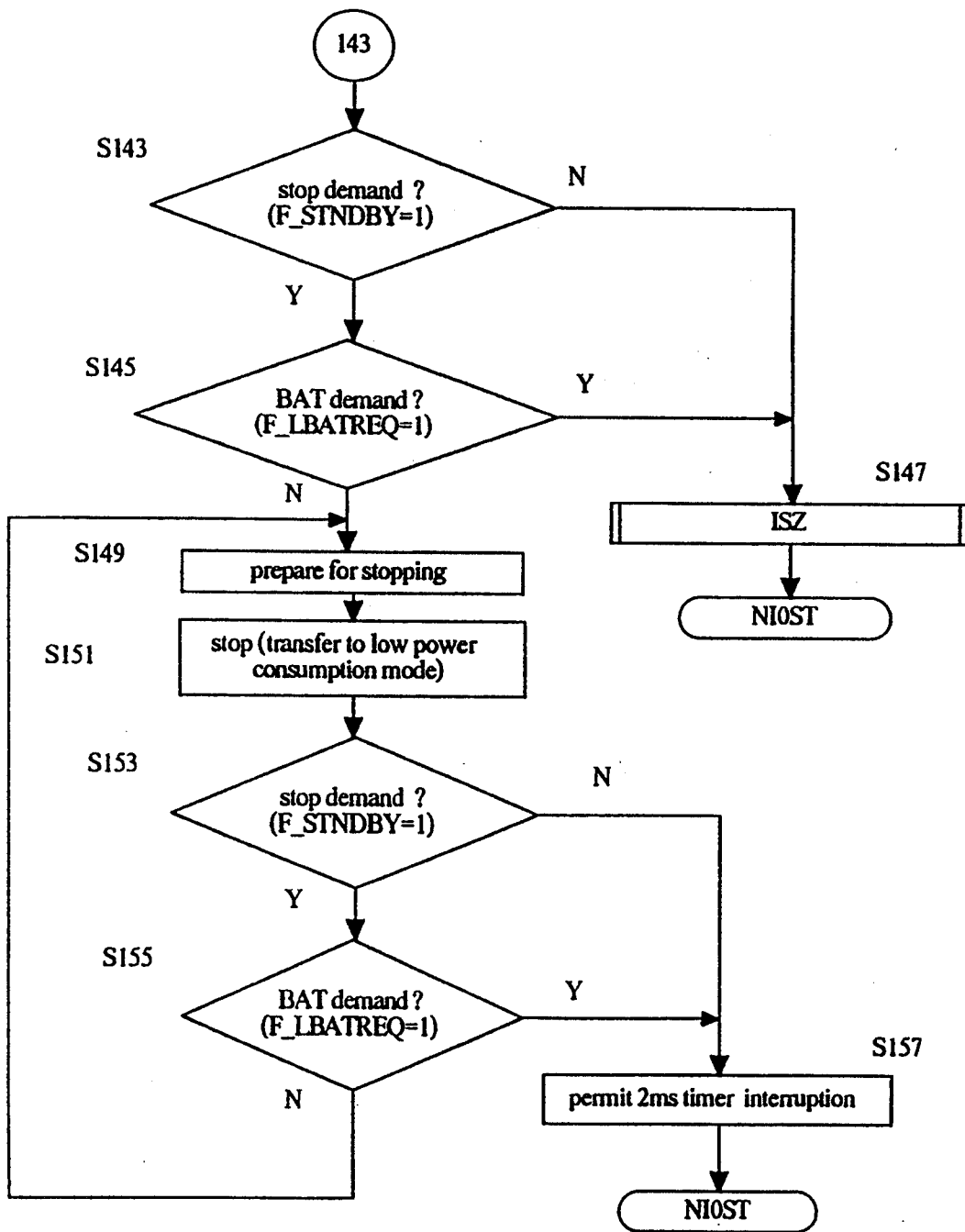

Fig. 8

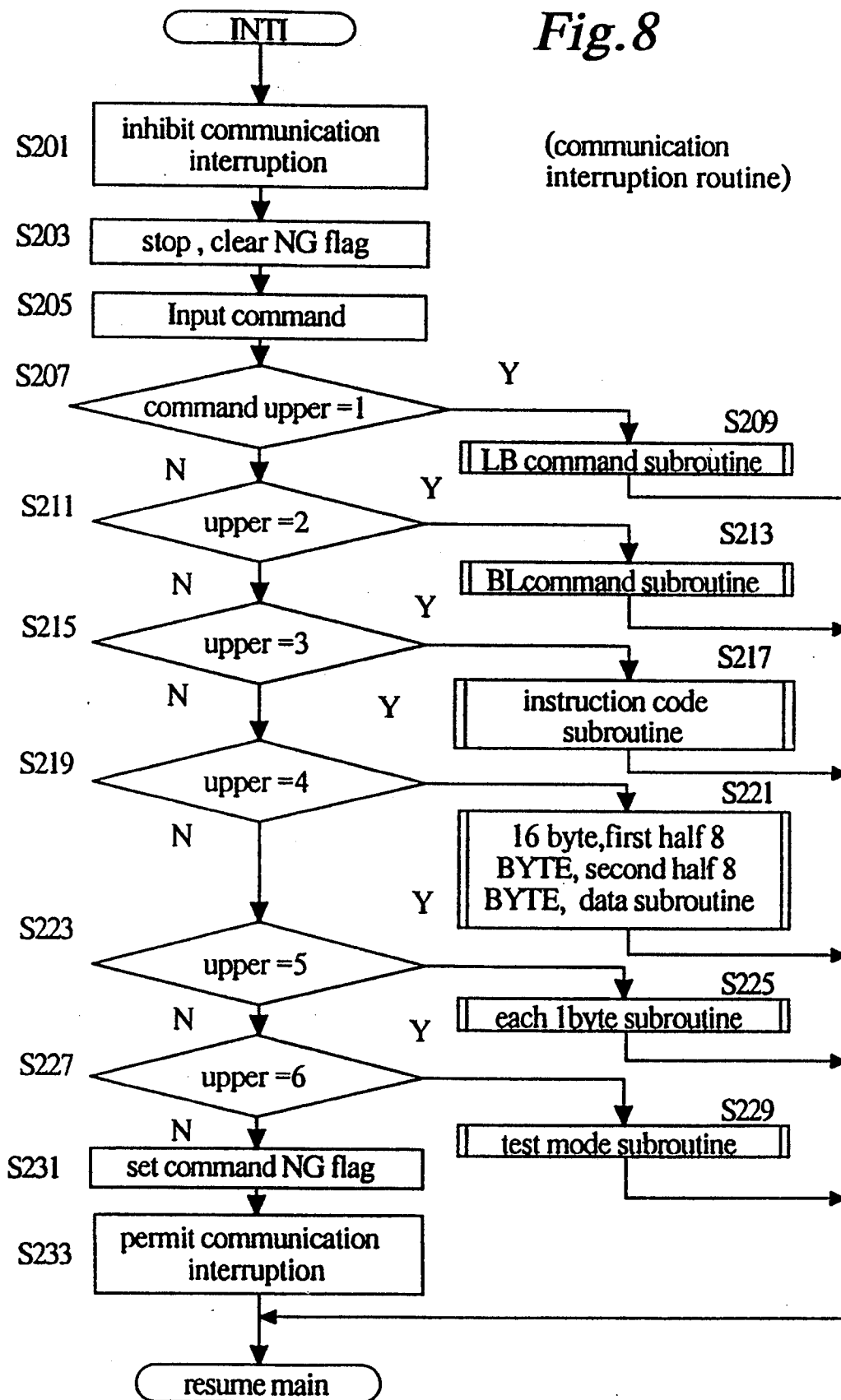

Fig. 9

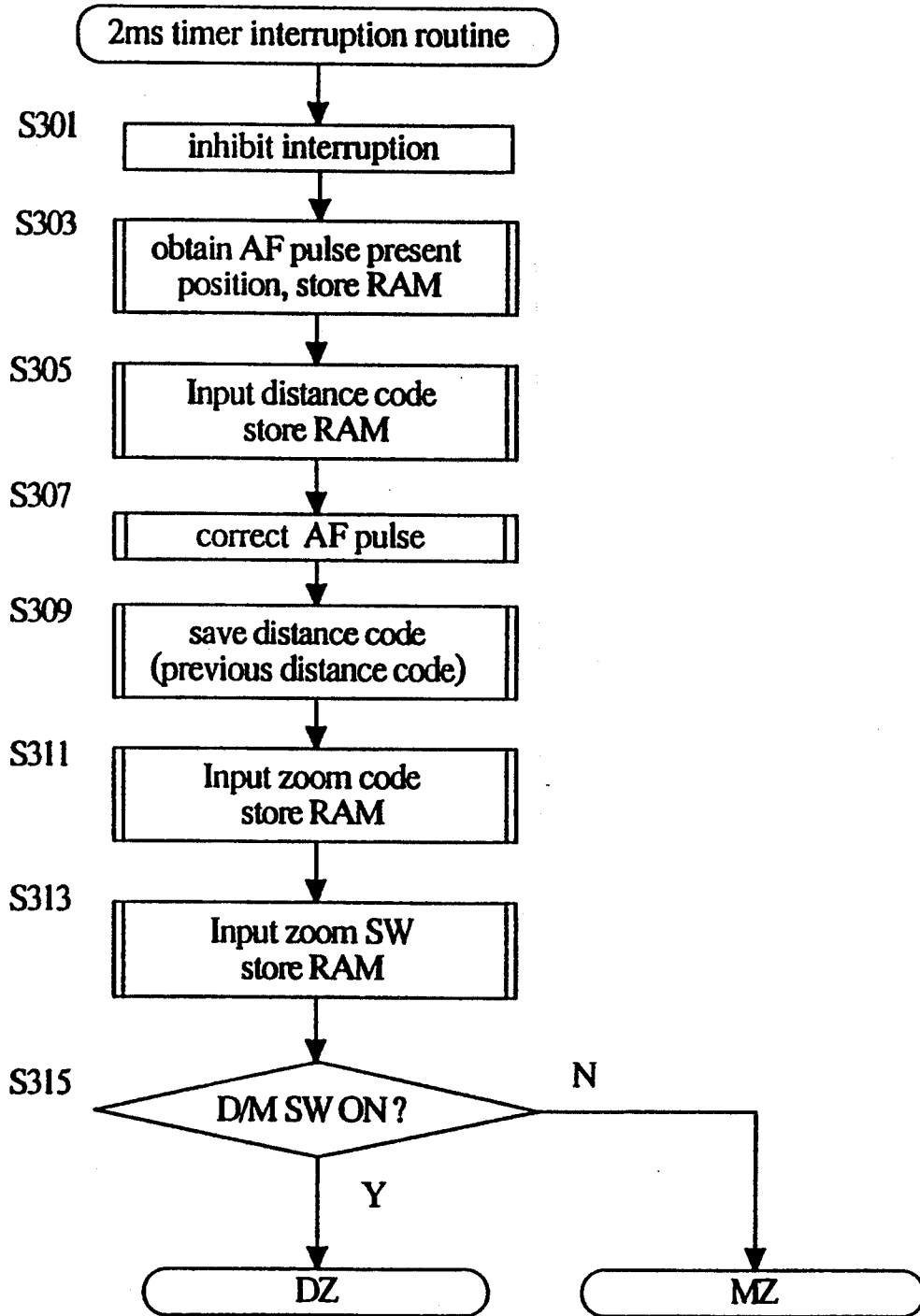

Fig. 10

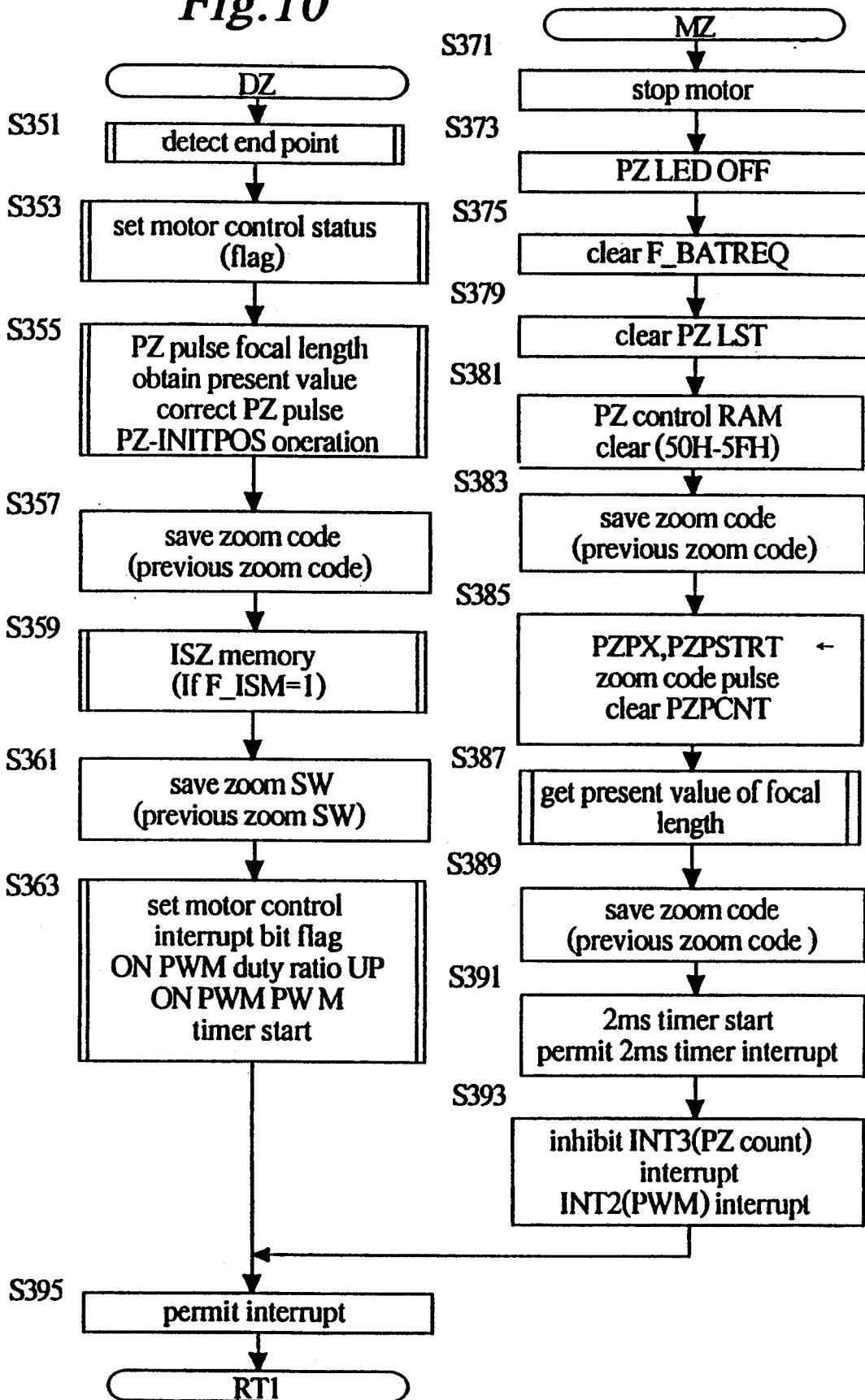

Fig. 11

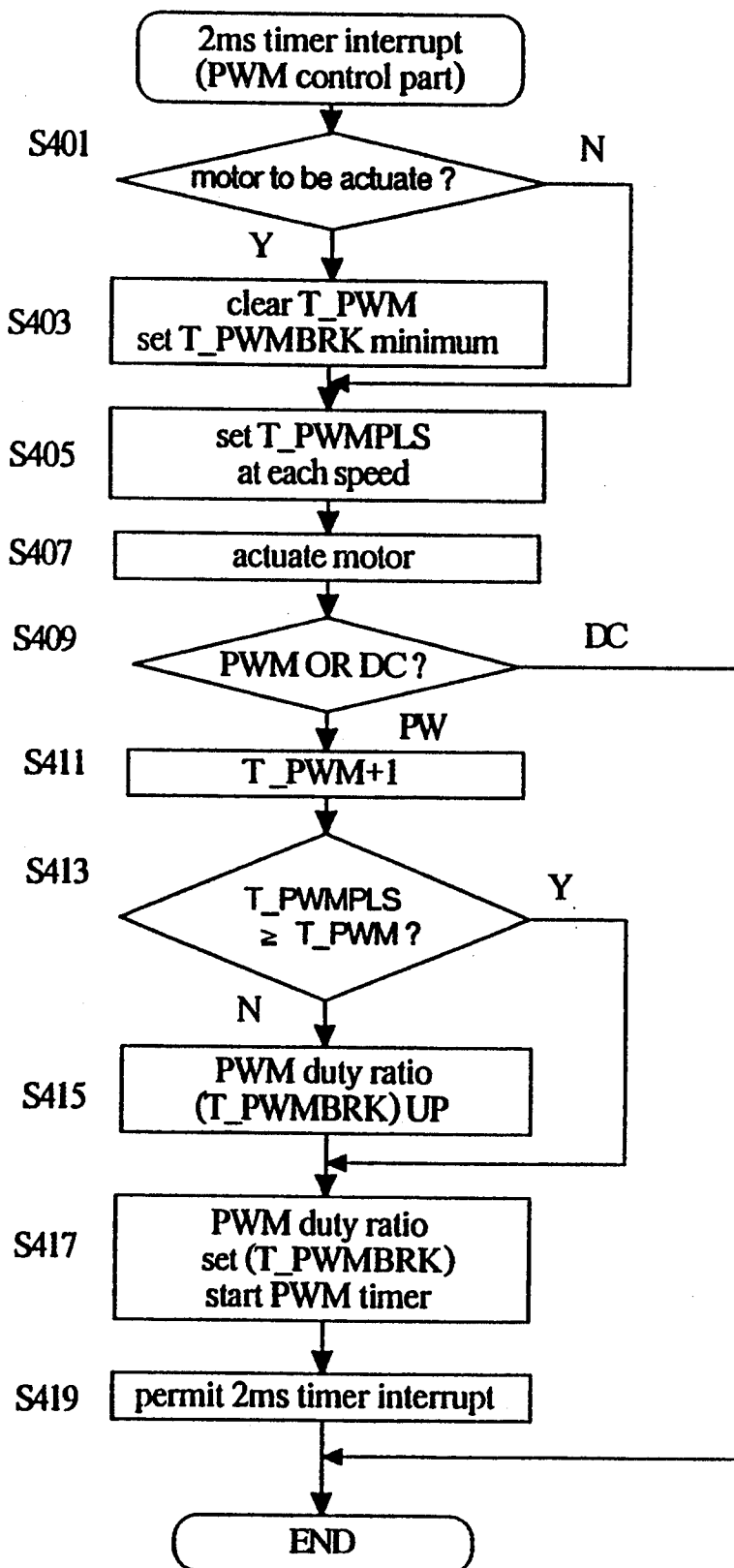

Fig. 12

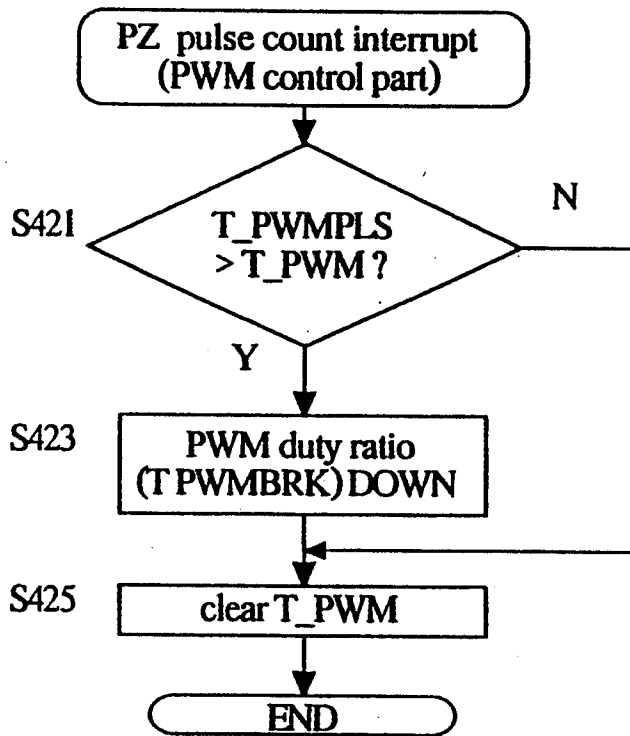

Fig. 13

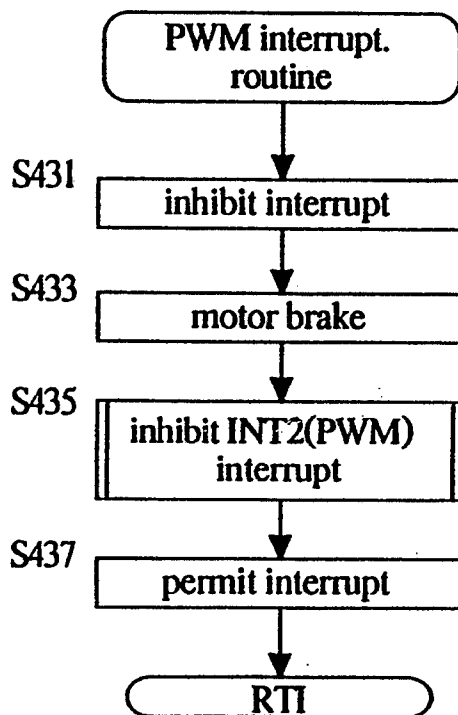

Fig. 14

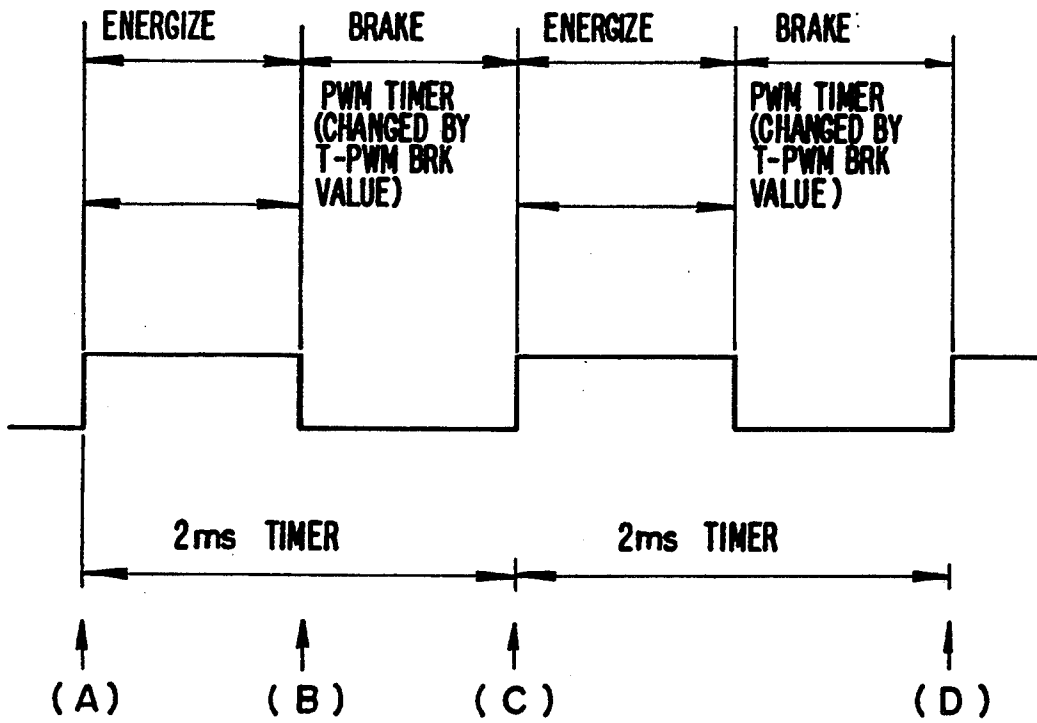

Fig. 15

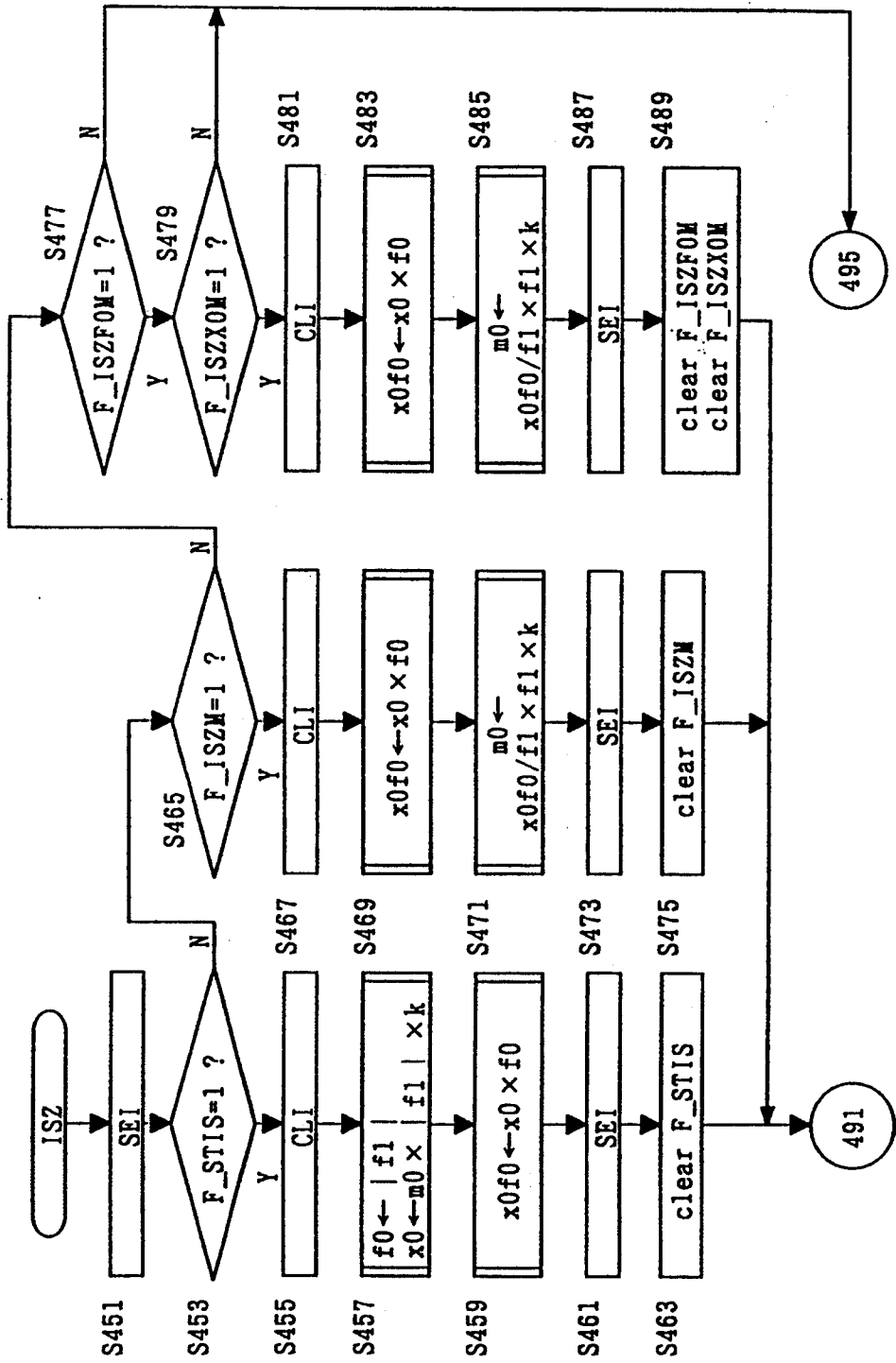

Fig. 16

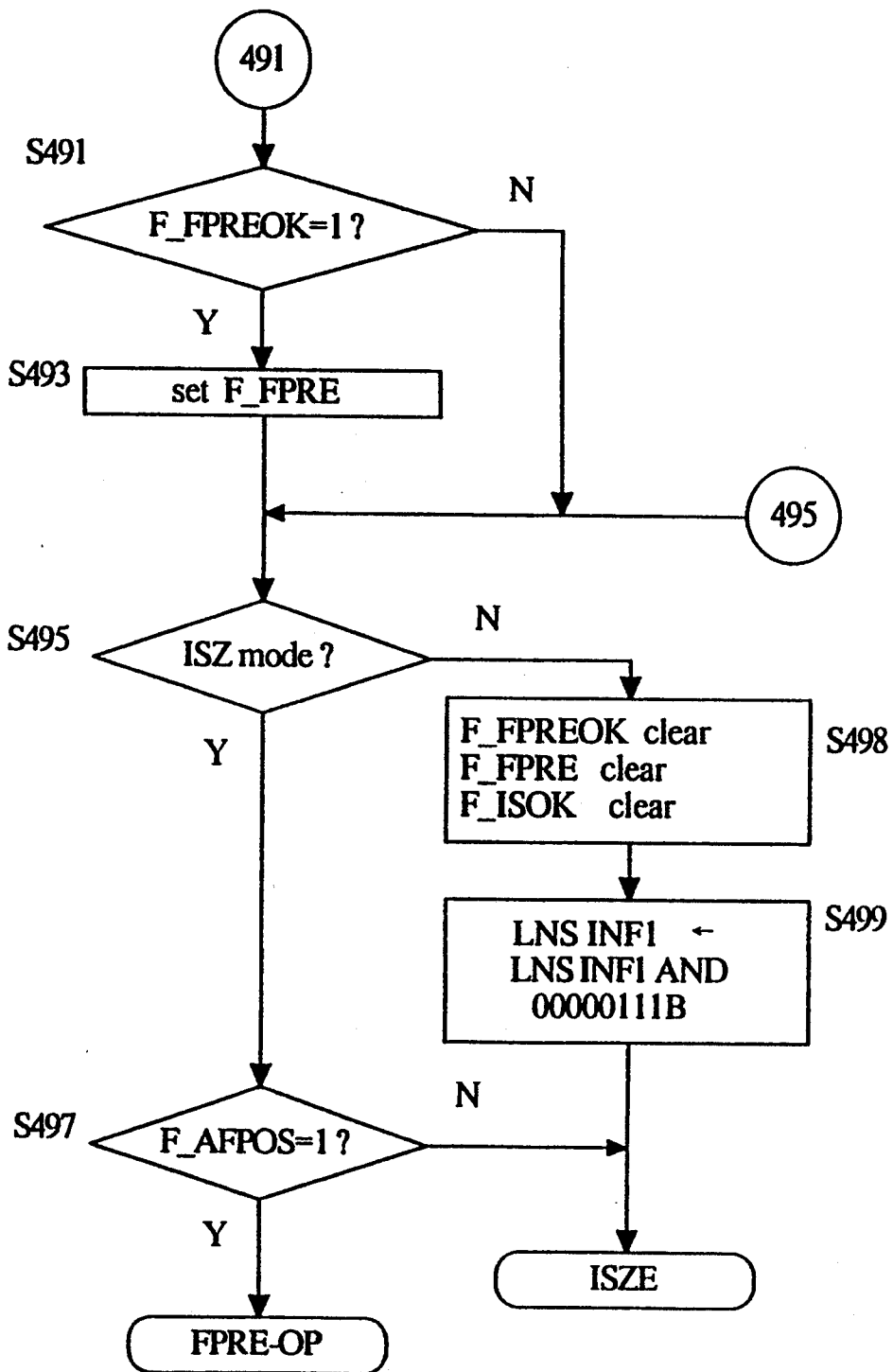

Fig. 17

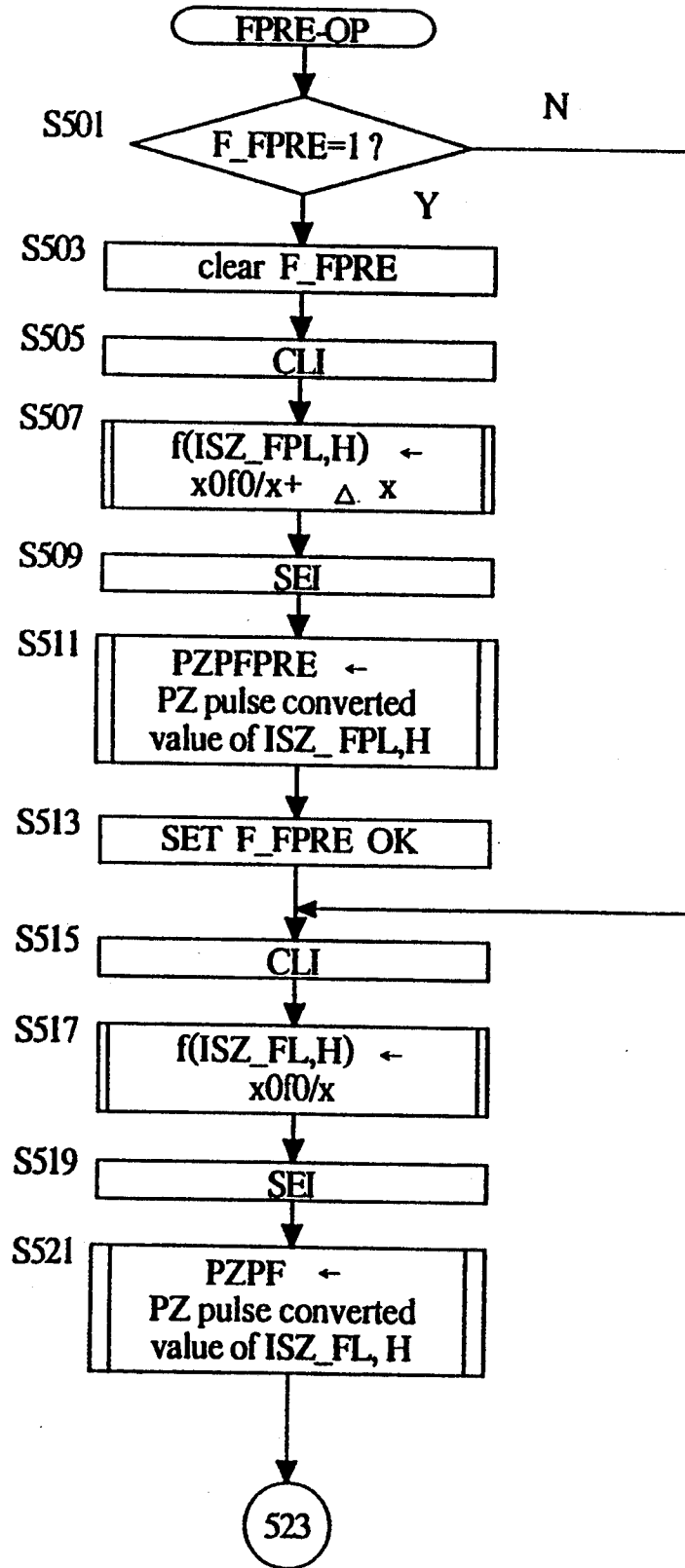

Fig.18

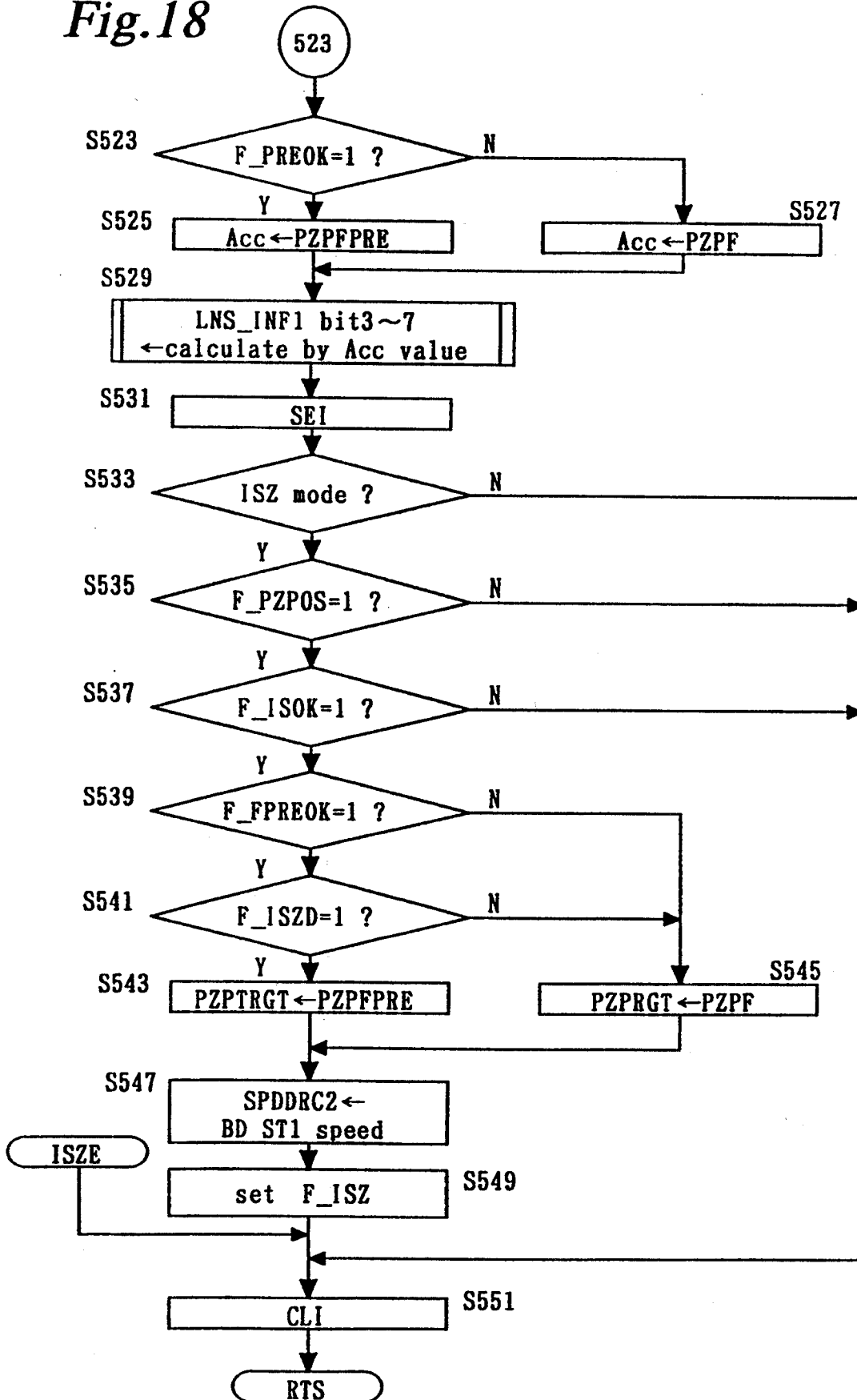

Fig.19

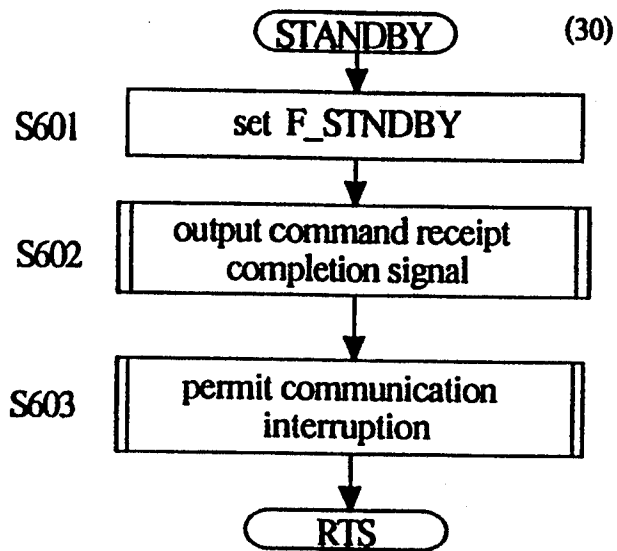

Fig.20

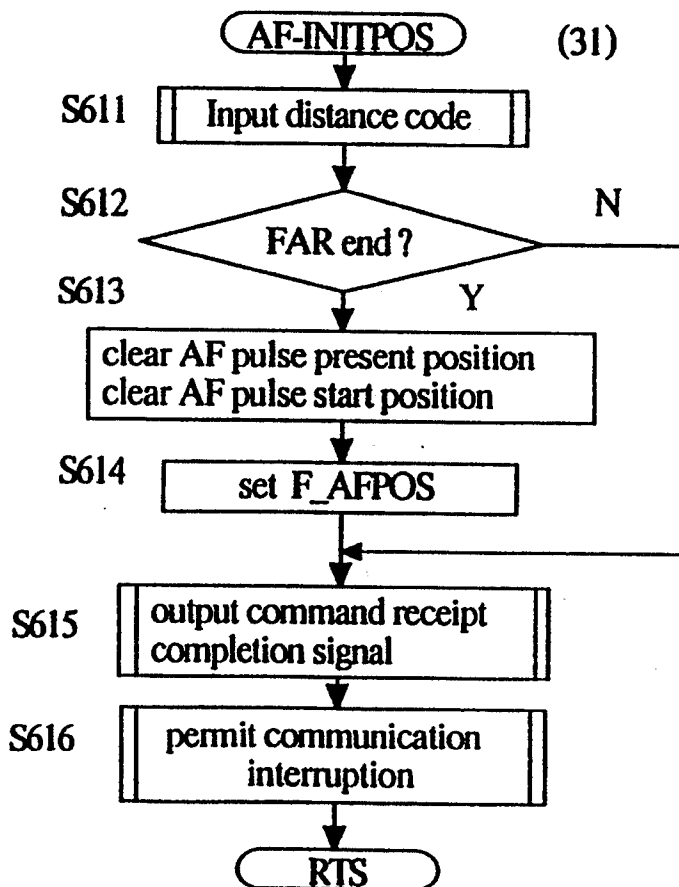

Fig.21

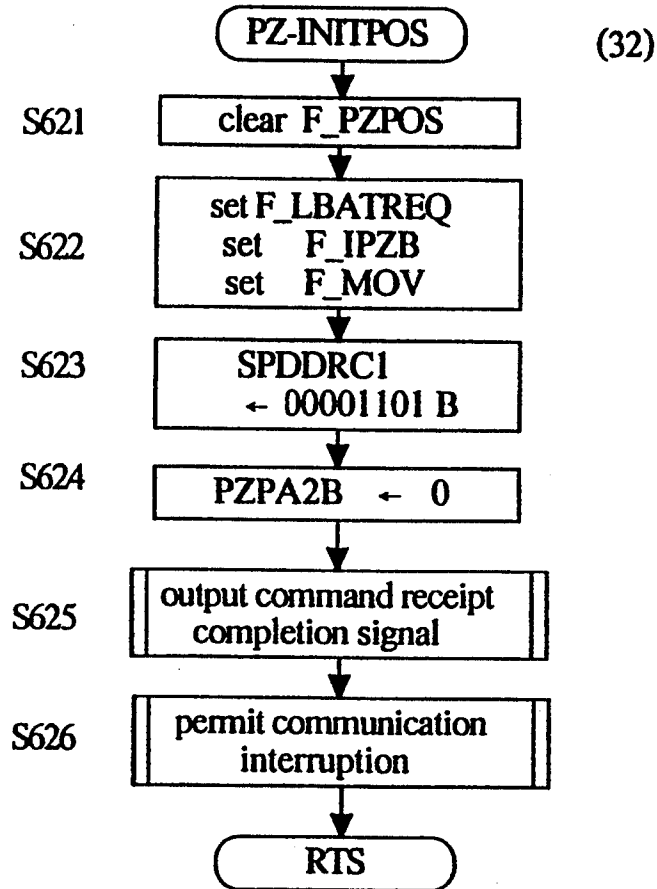

Fig.24

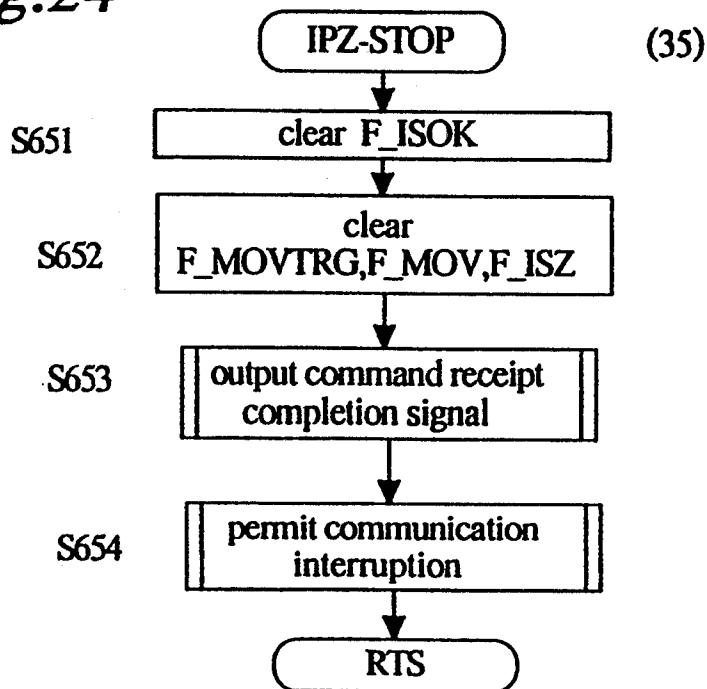

Fig.22

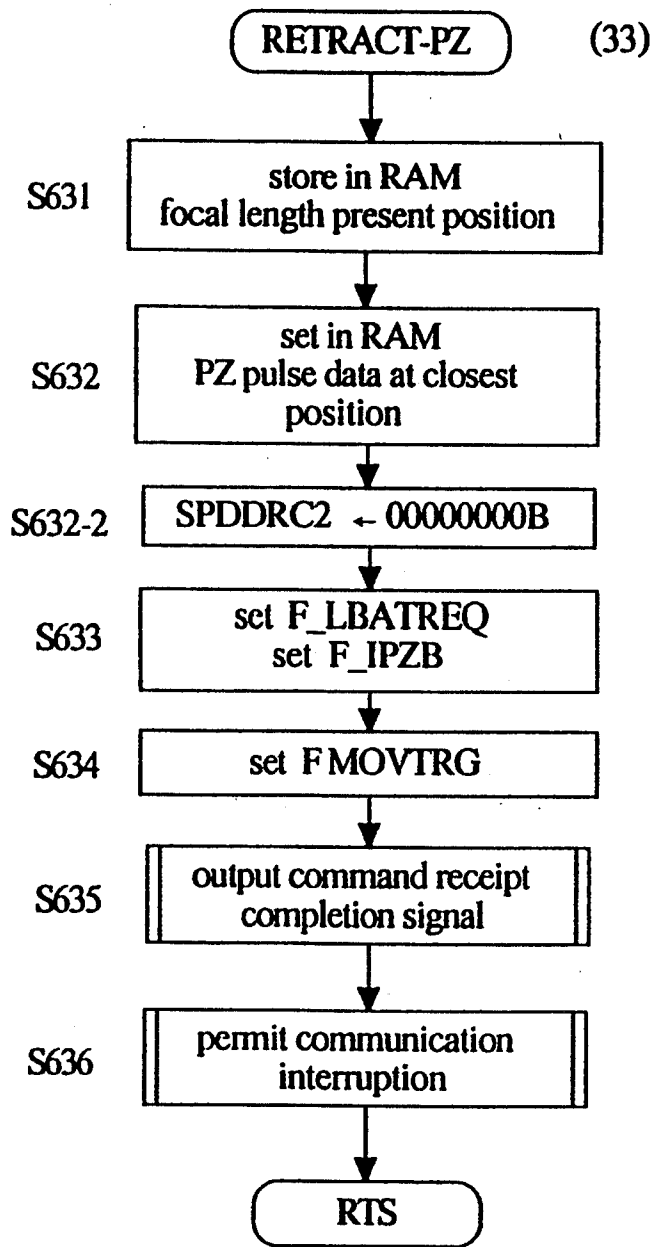

Fig.23

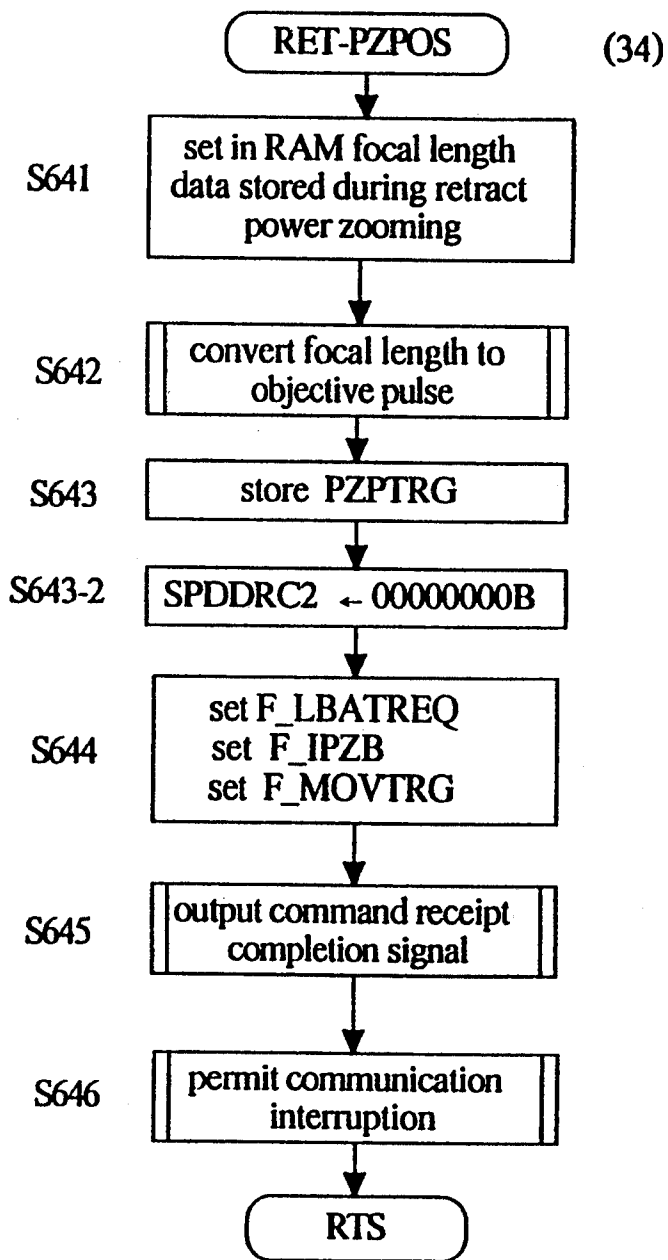

Fig.25

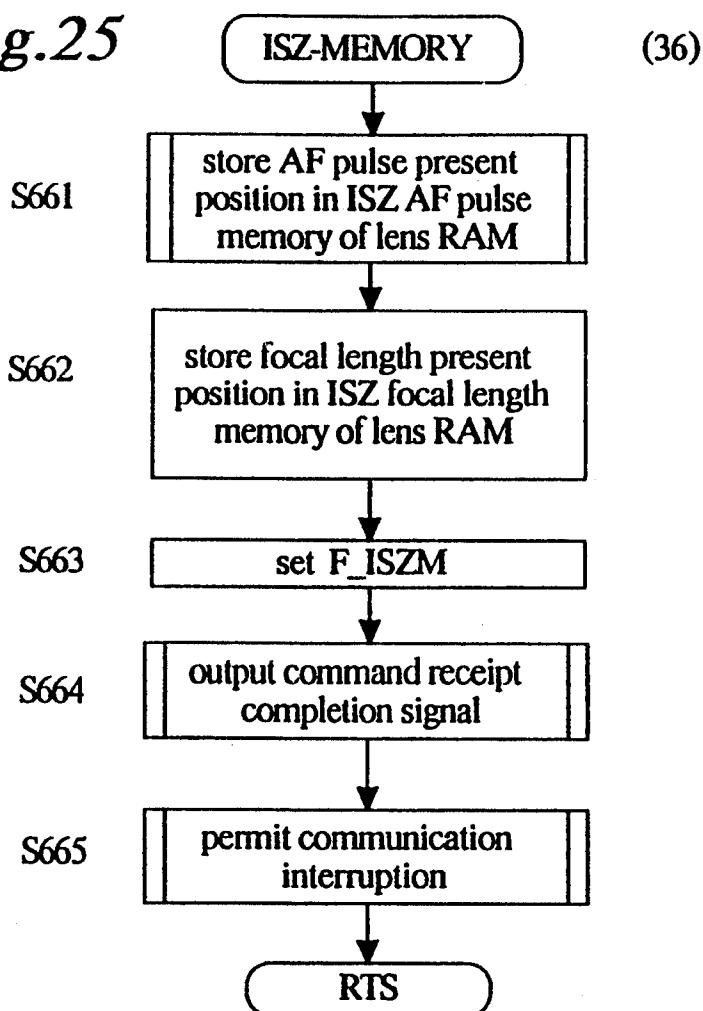

Fig.26

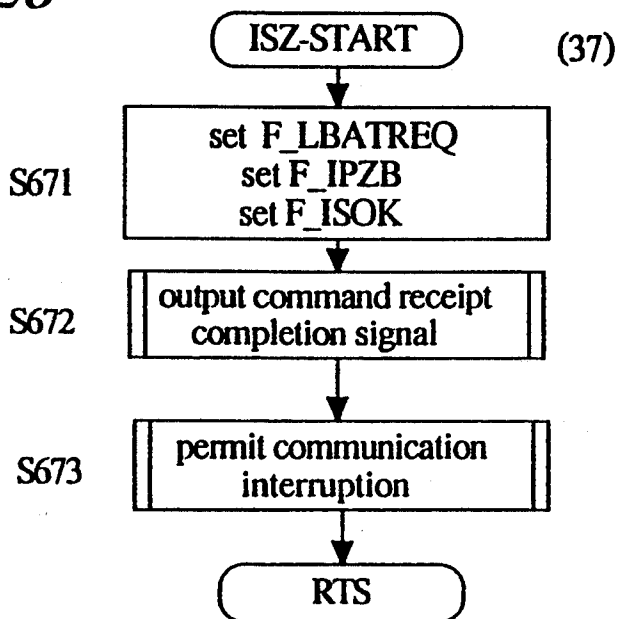

Fig.27

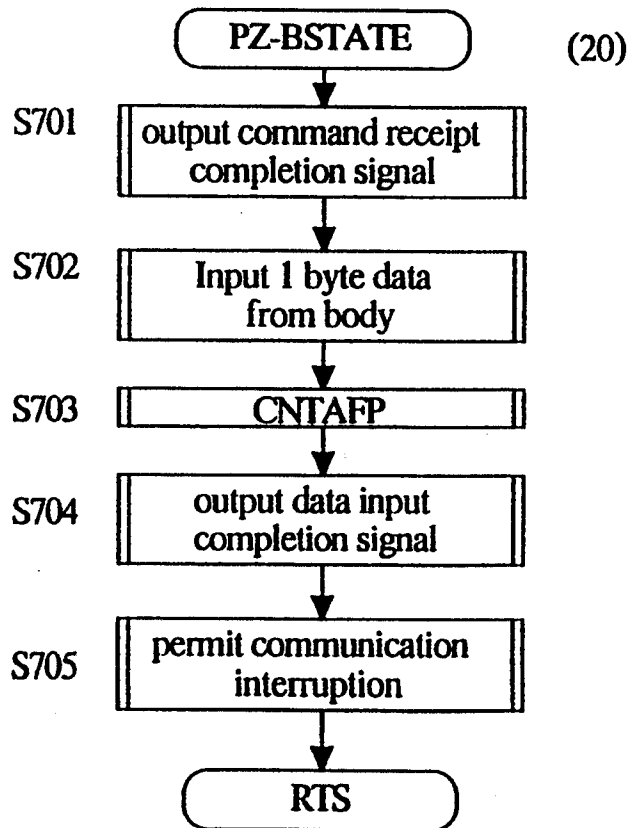

Fig.28

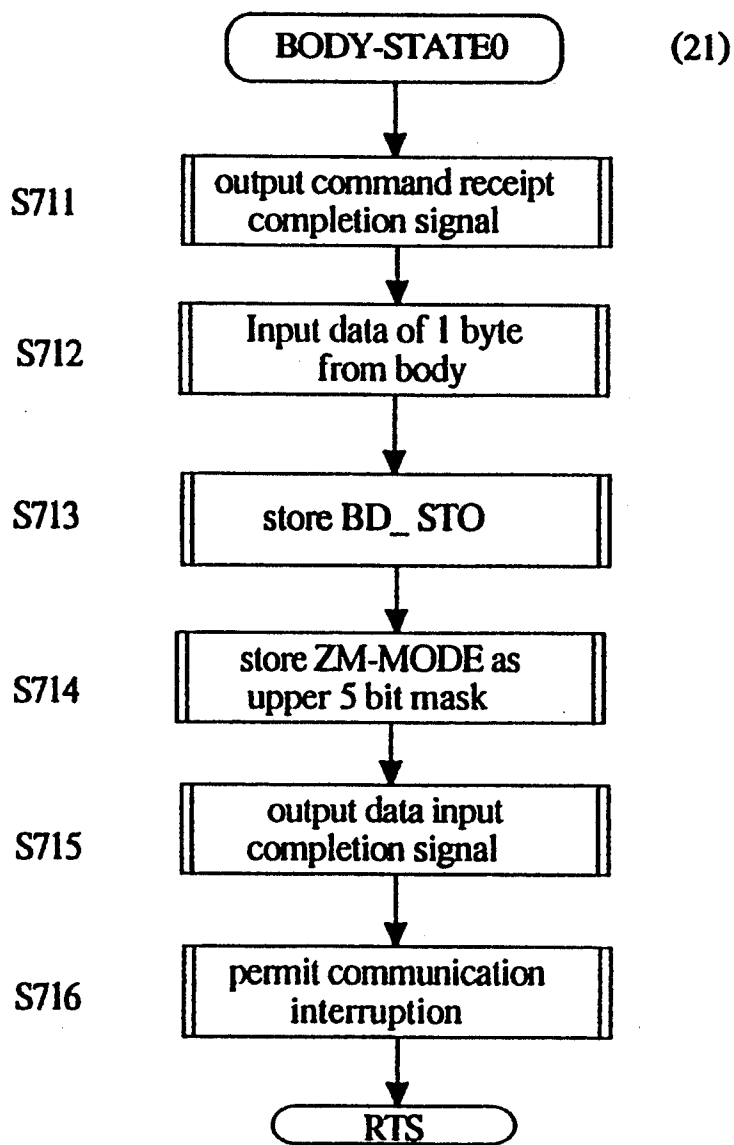

Fig.29

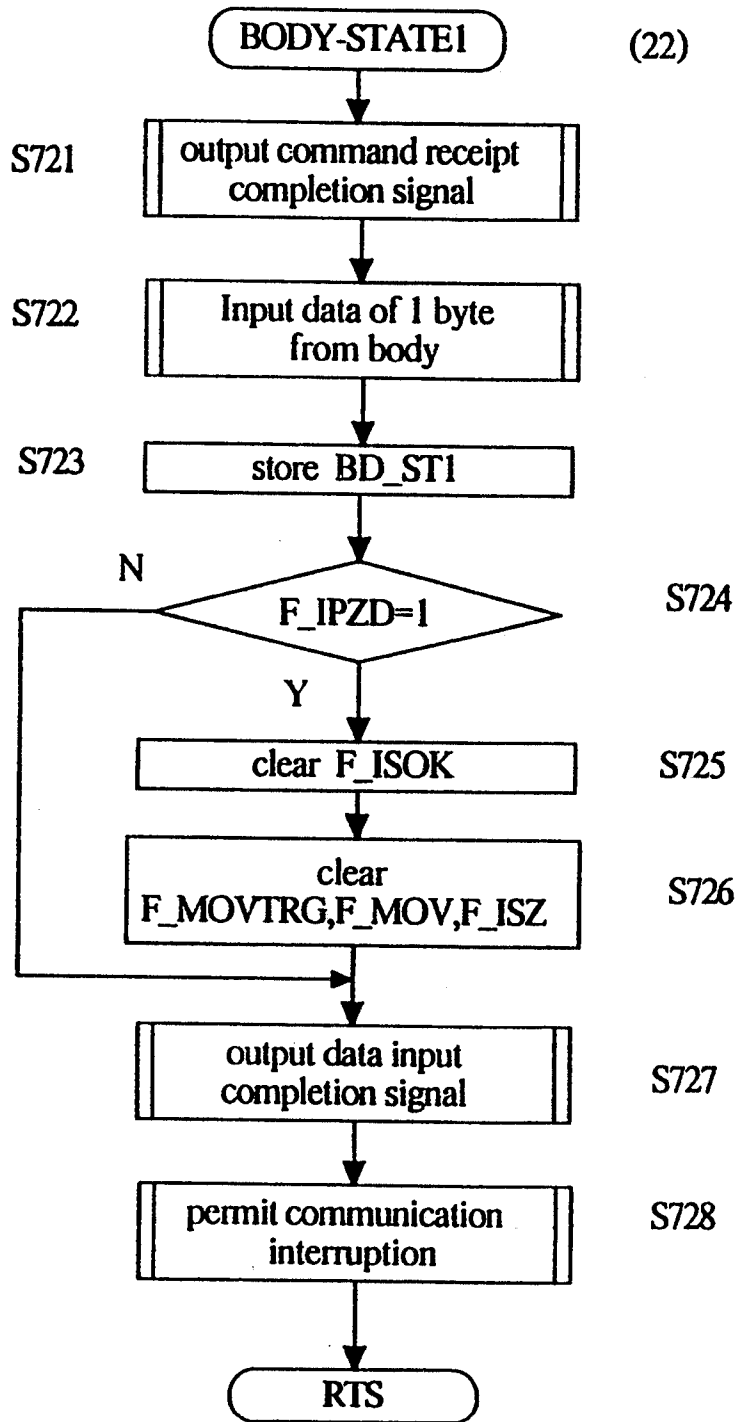

Fig.30

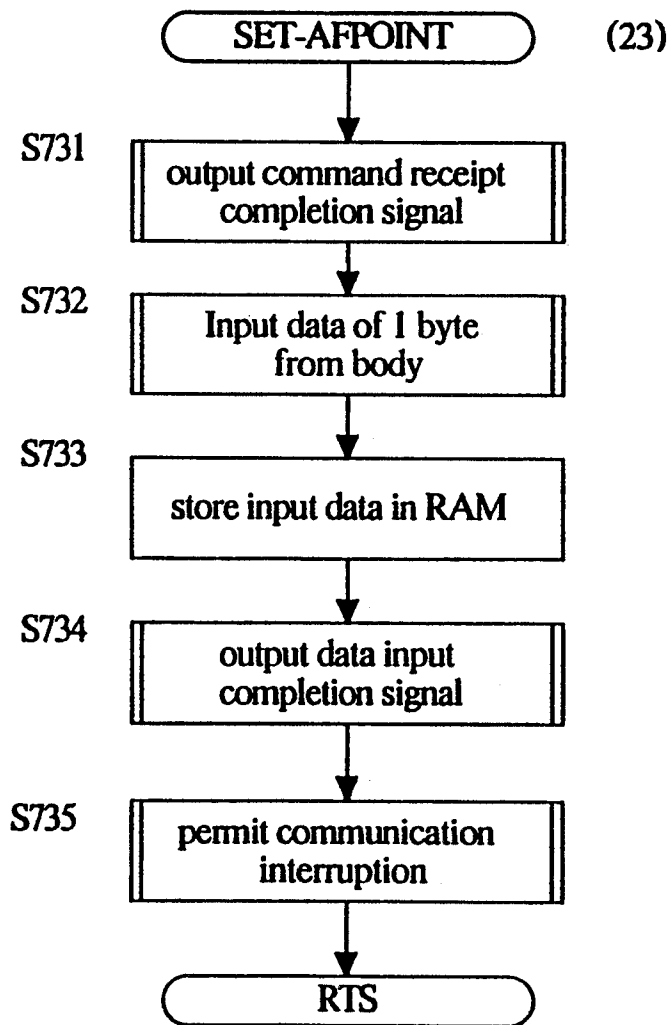

Fig.31

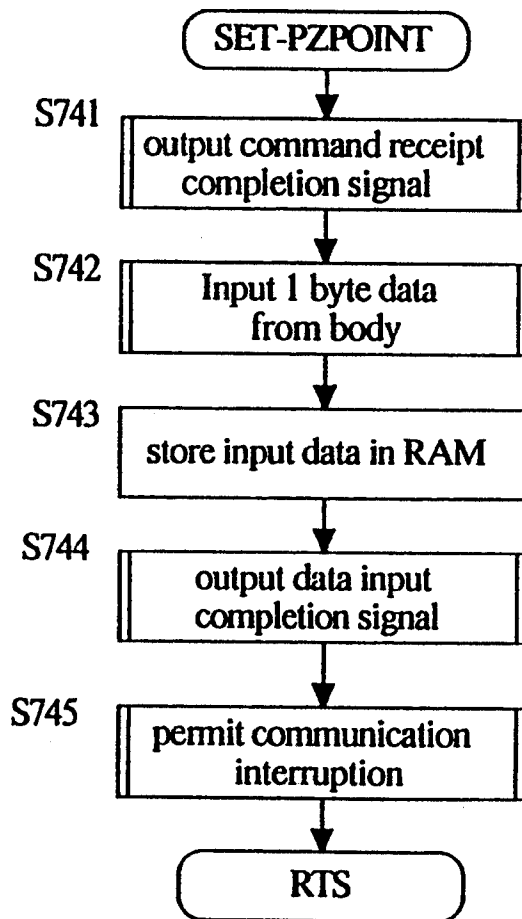

Fig.32

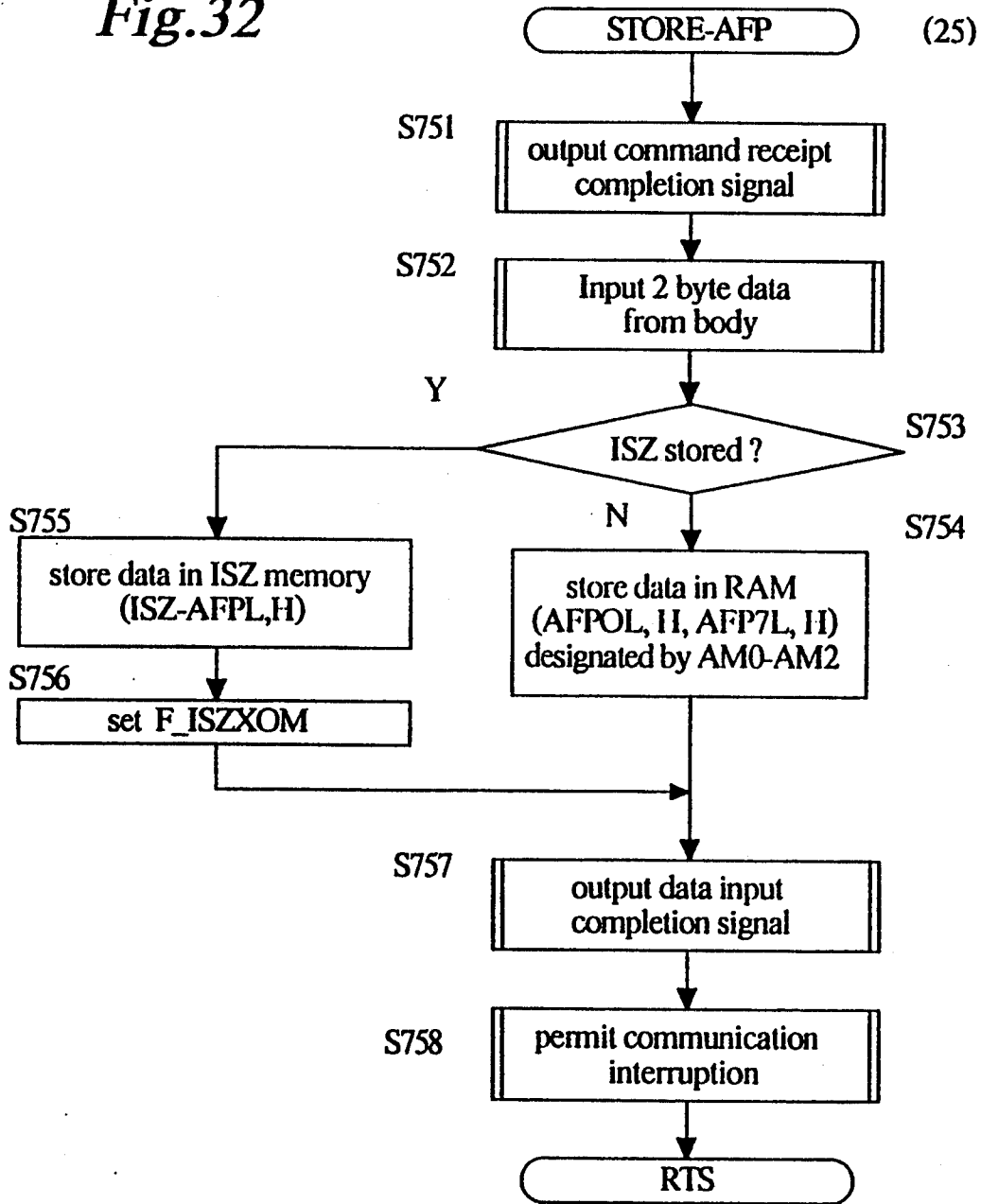

Fig.33

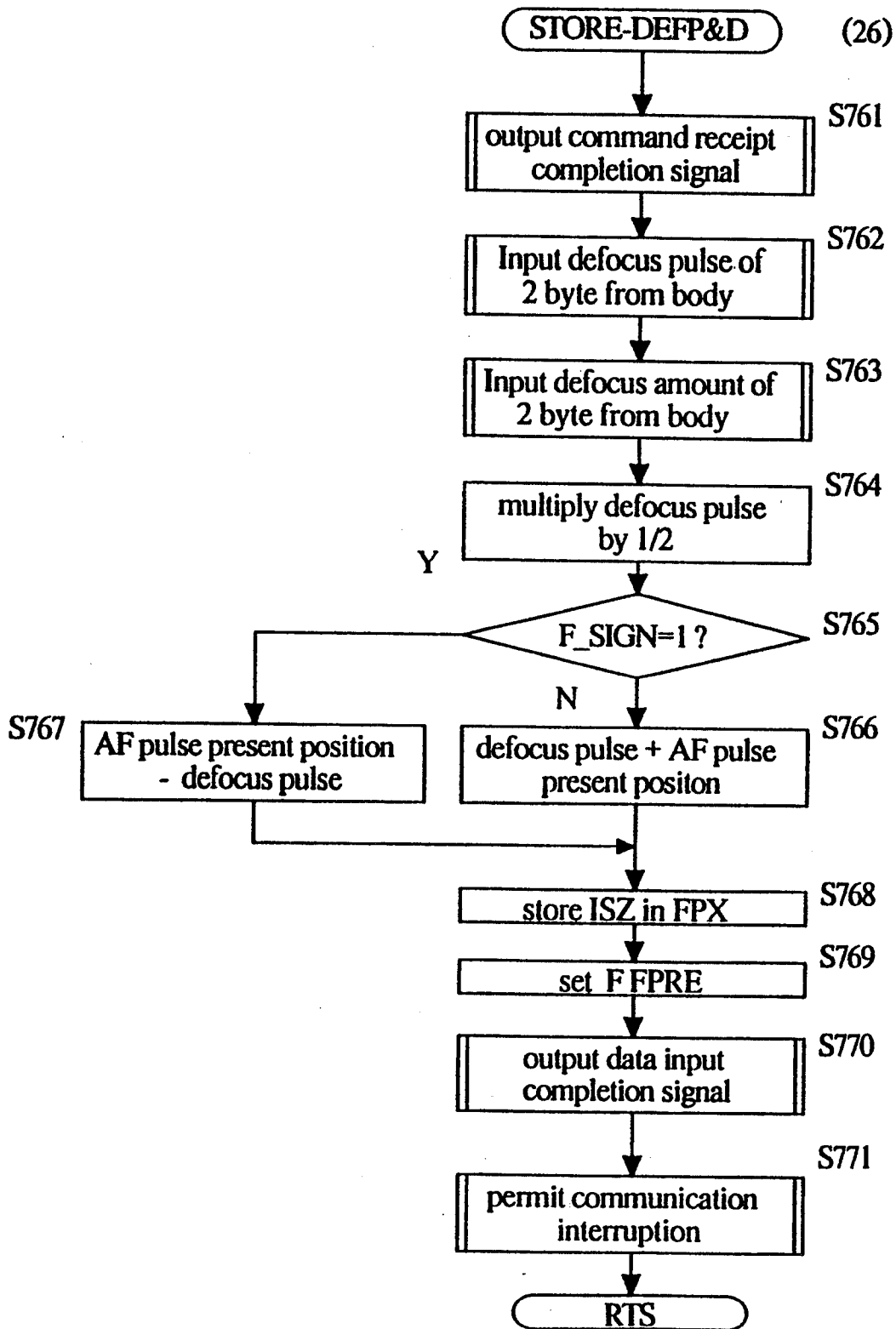

Fig.34

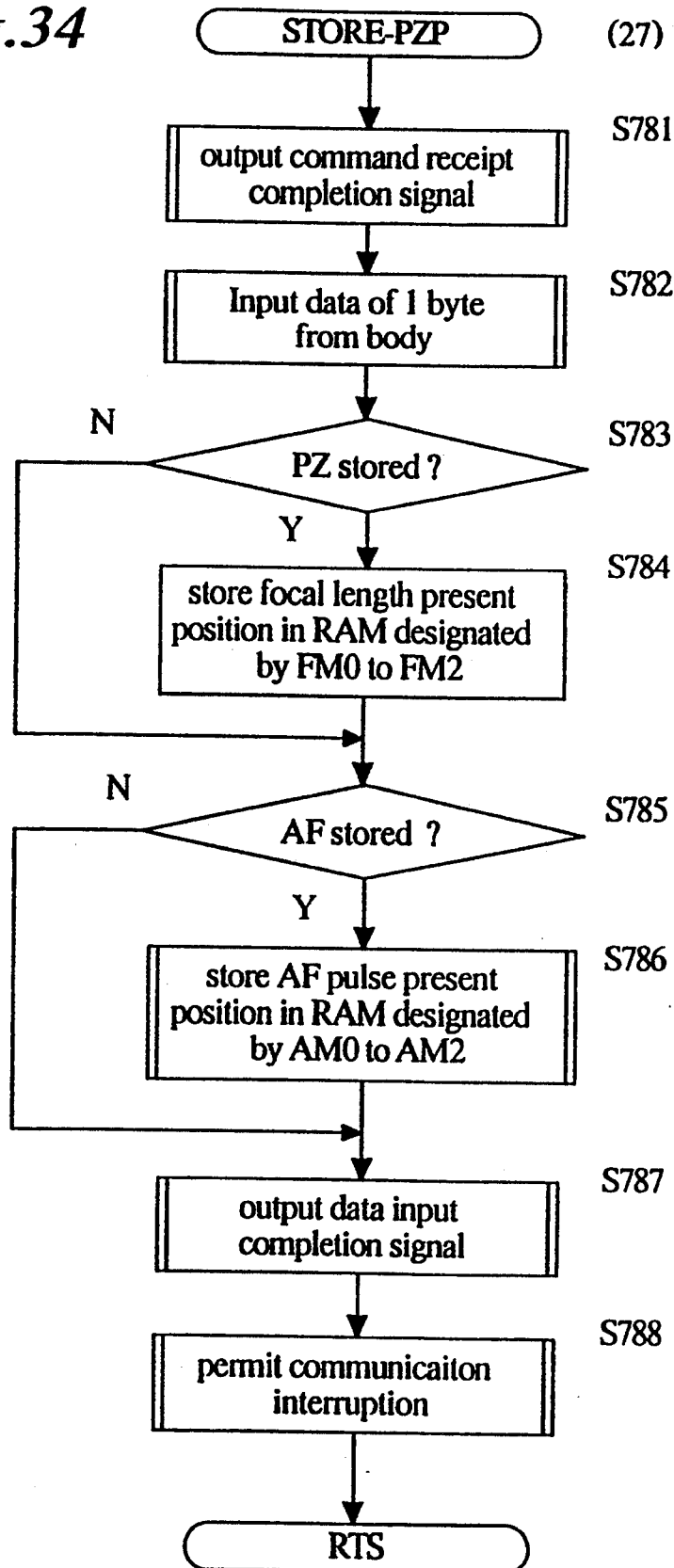

Fig.35

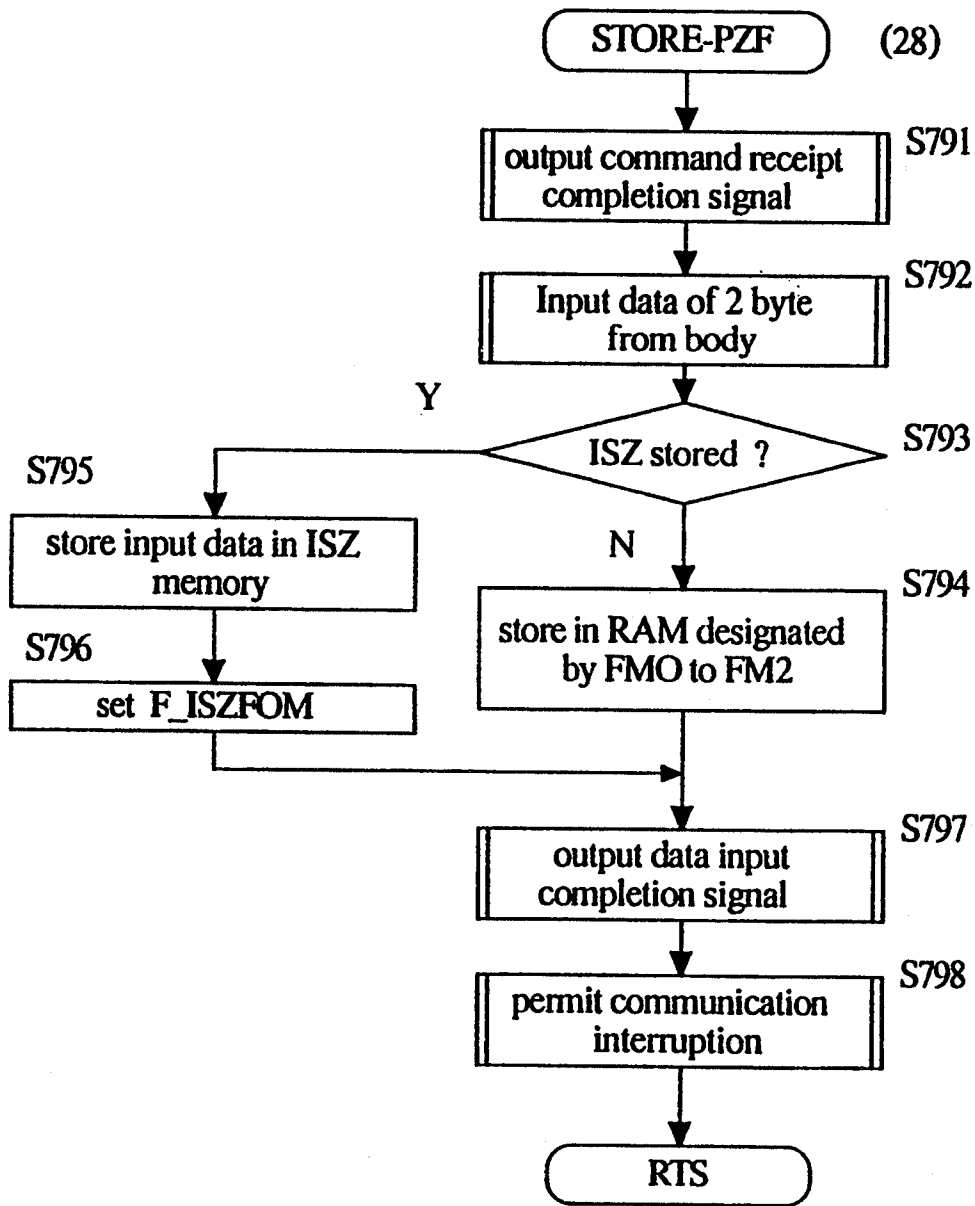

Fig.36

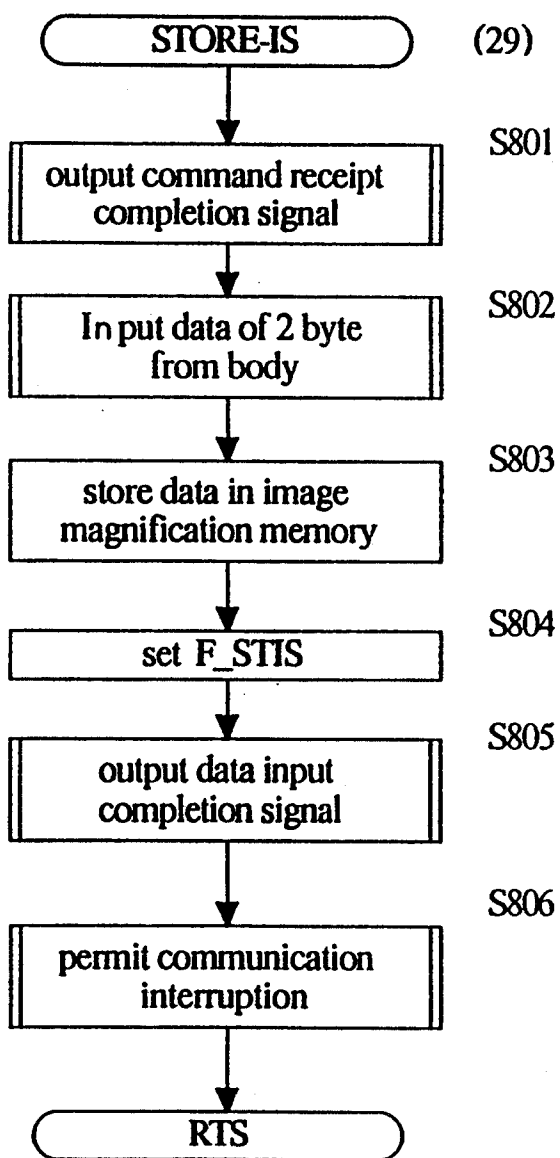

Fig.37

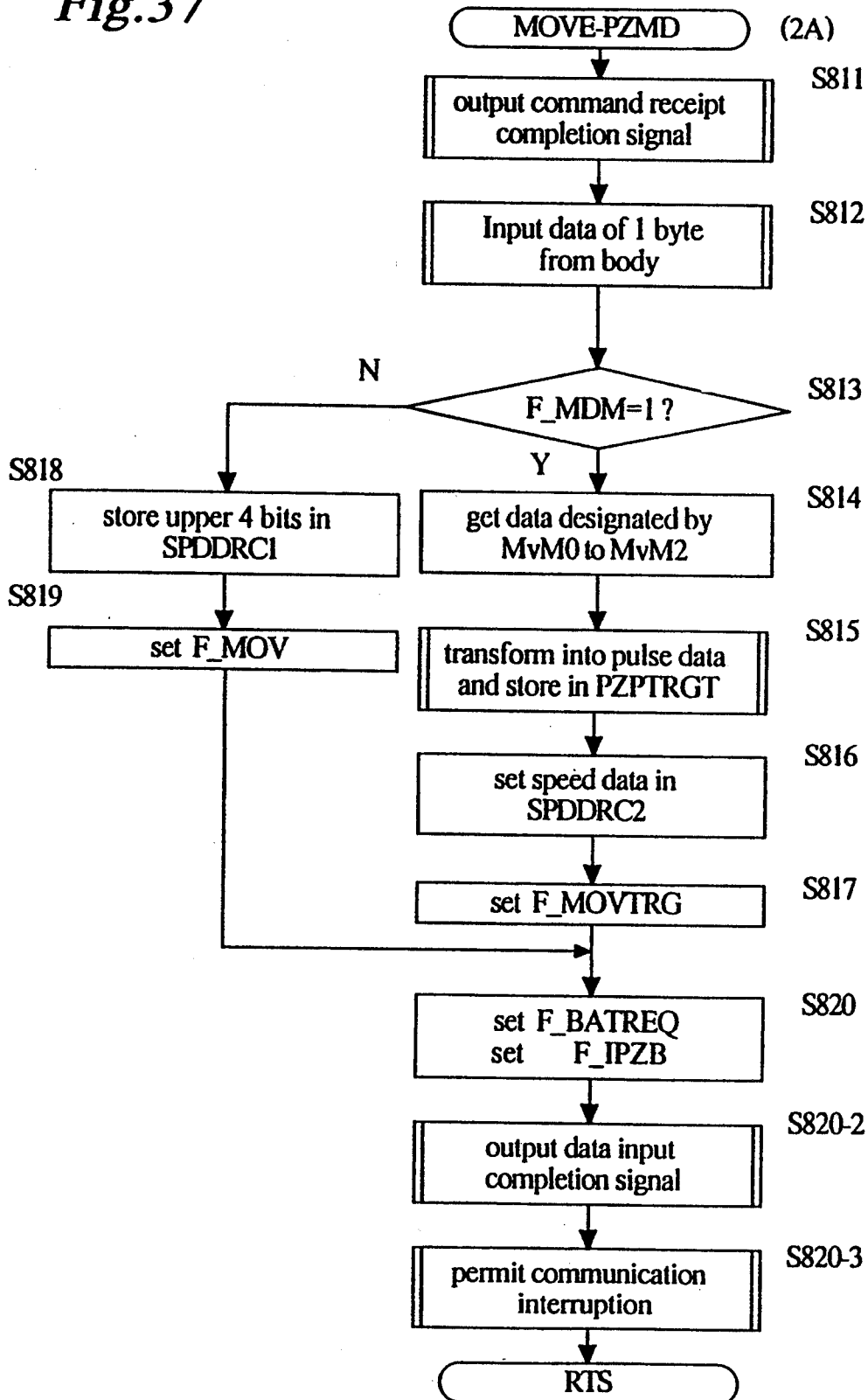

Fig.38

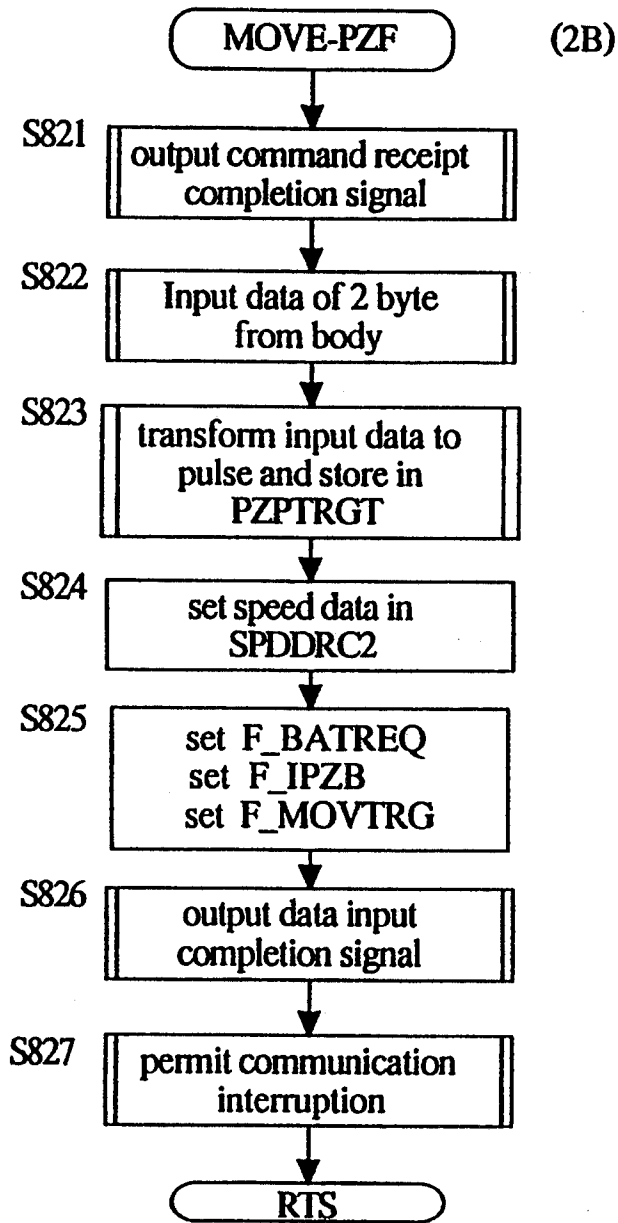

Fig. 39

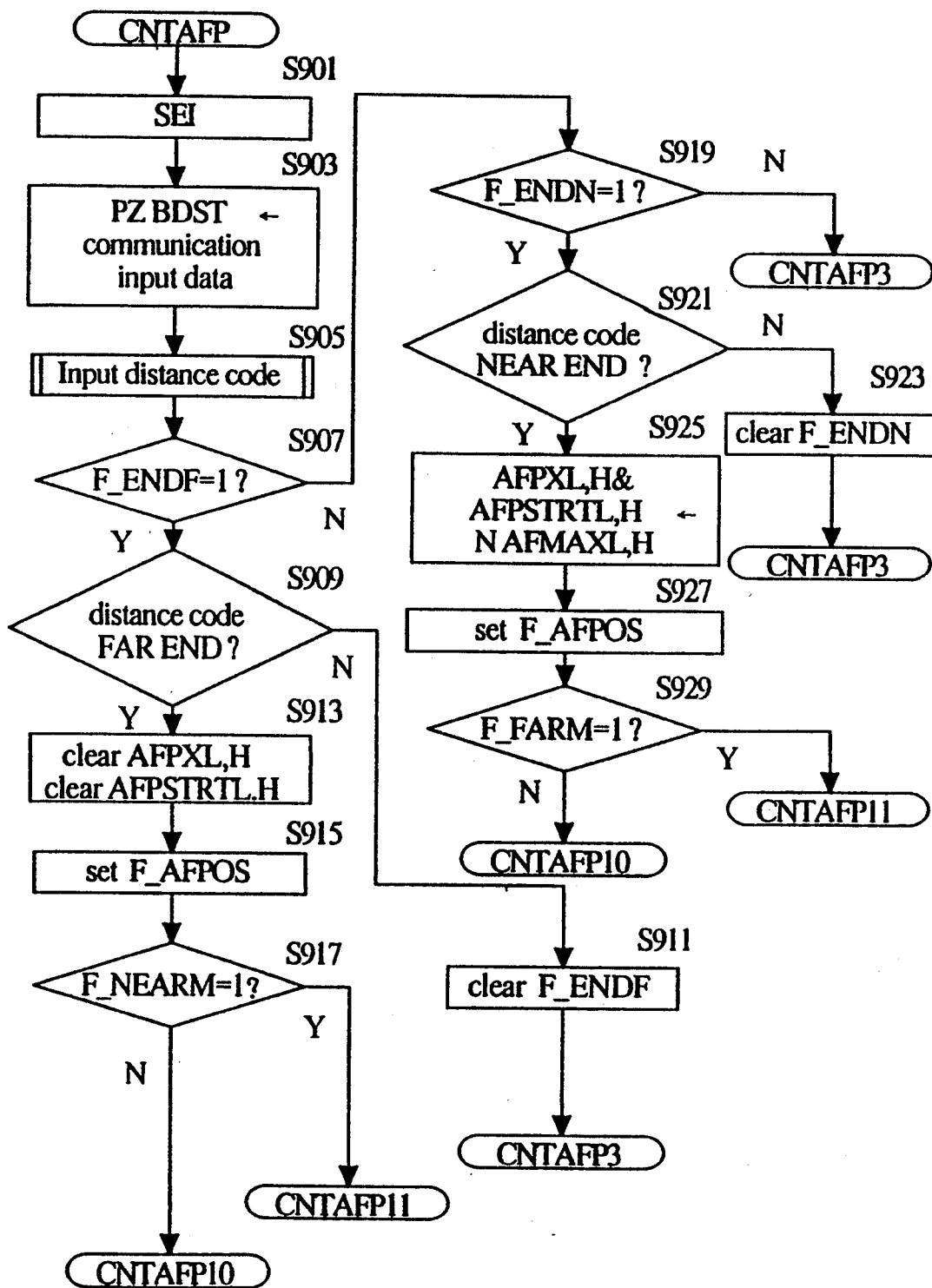

Fig.40

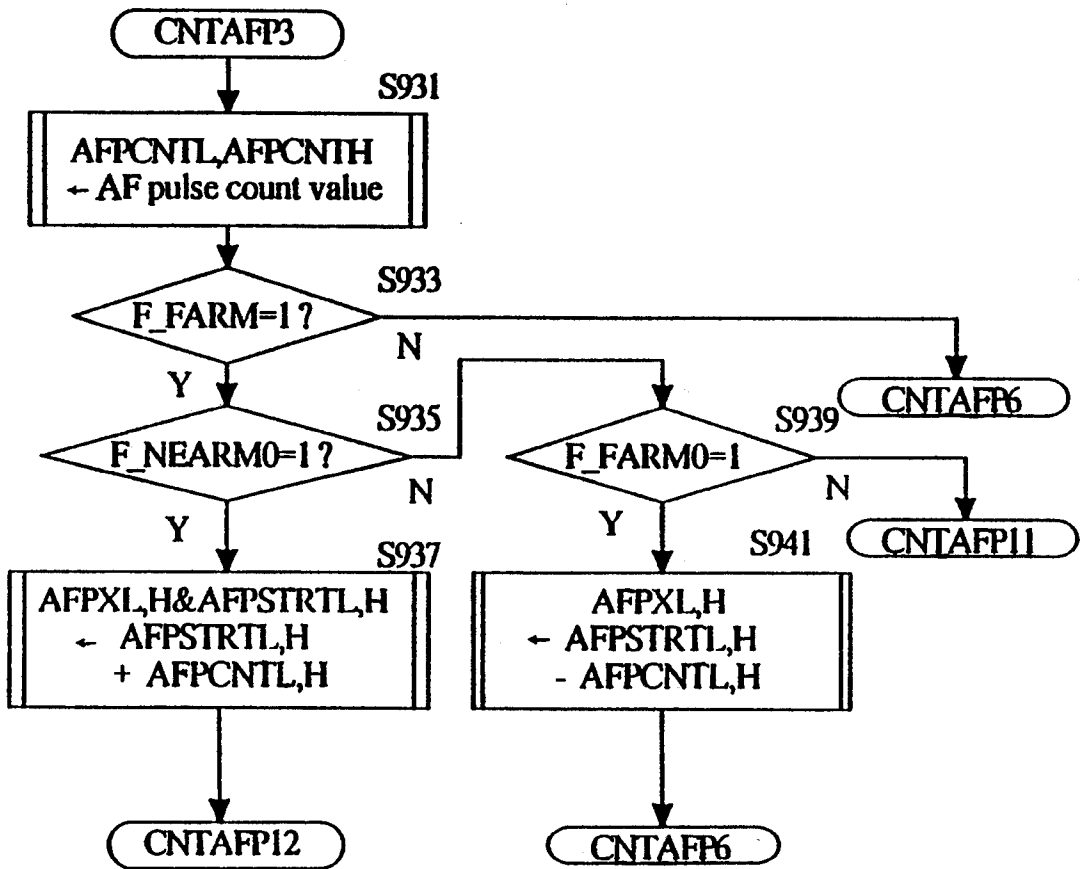

Fig.41

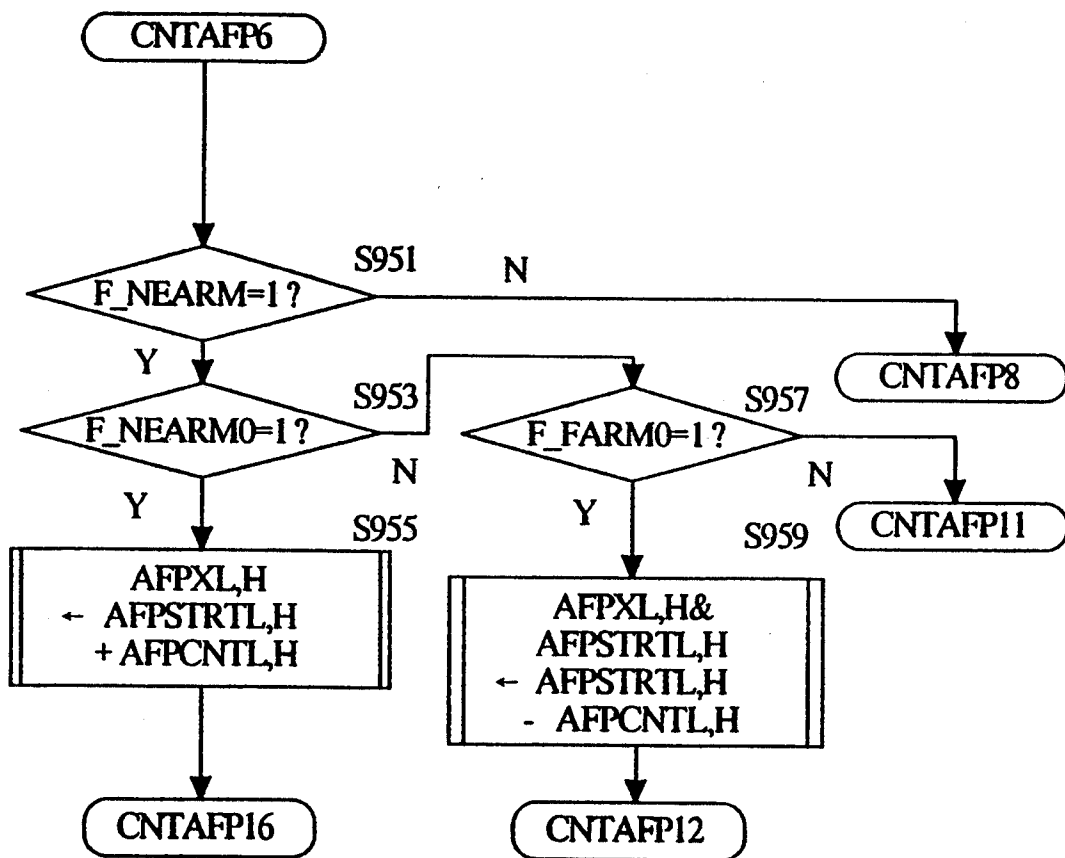

Fig.42

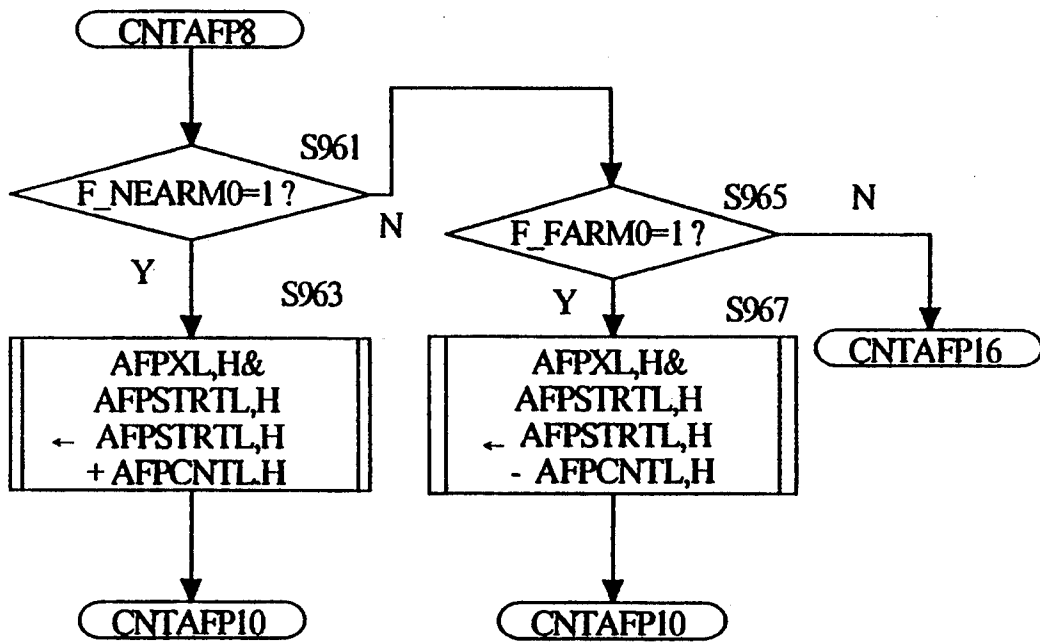

Fig. 43

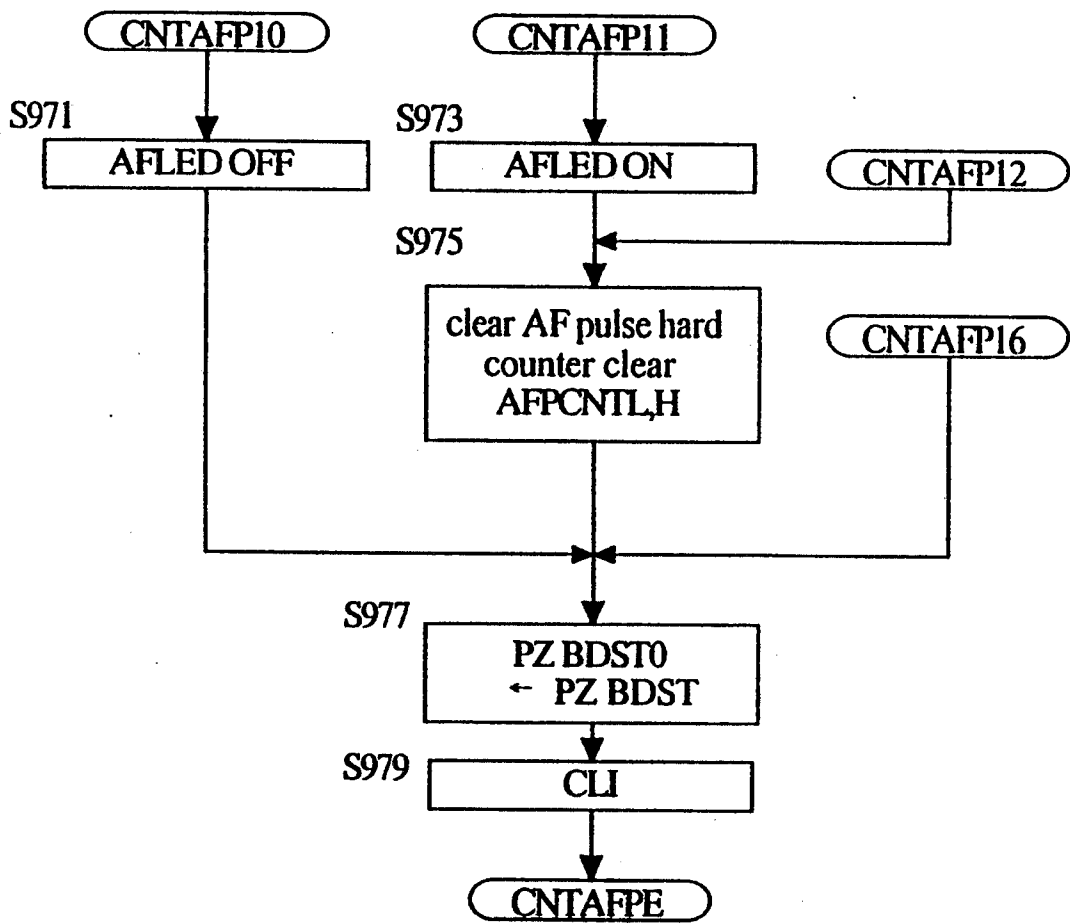
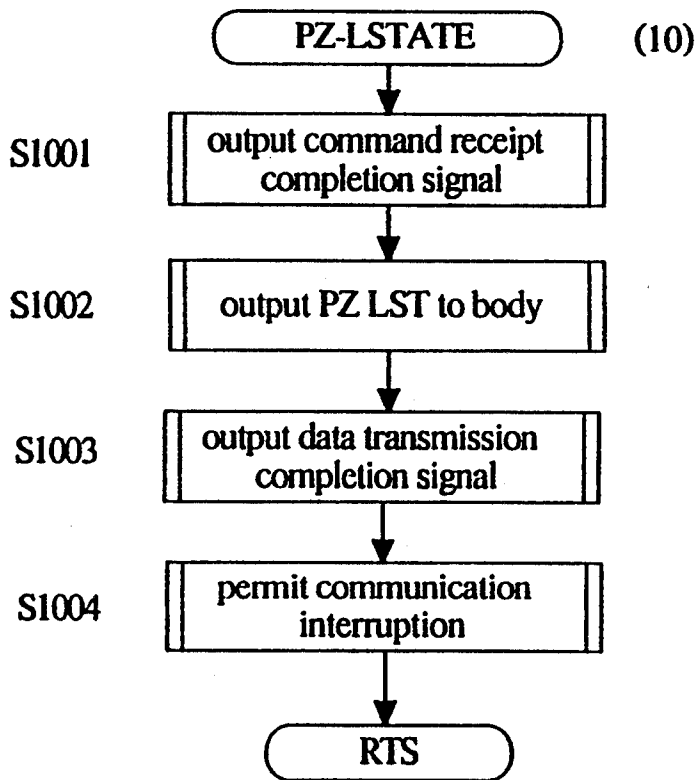

Fig.44



(11) POFF-STATE POFFS-WSLEEP (12) Fig.45

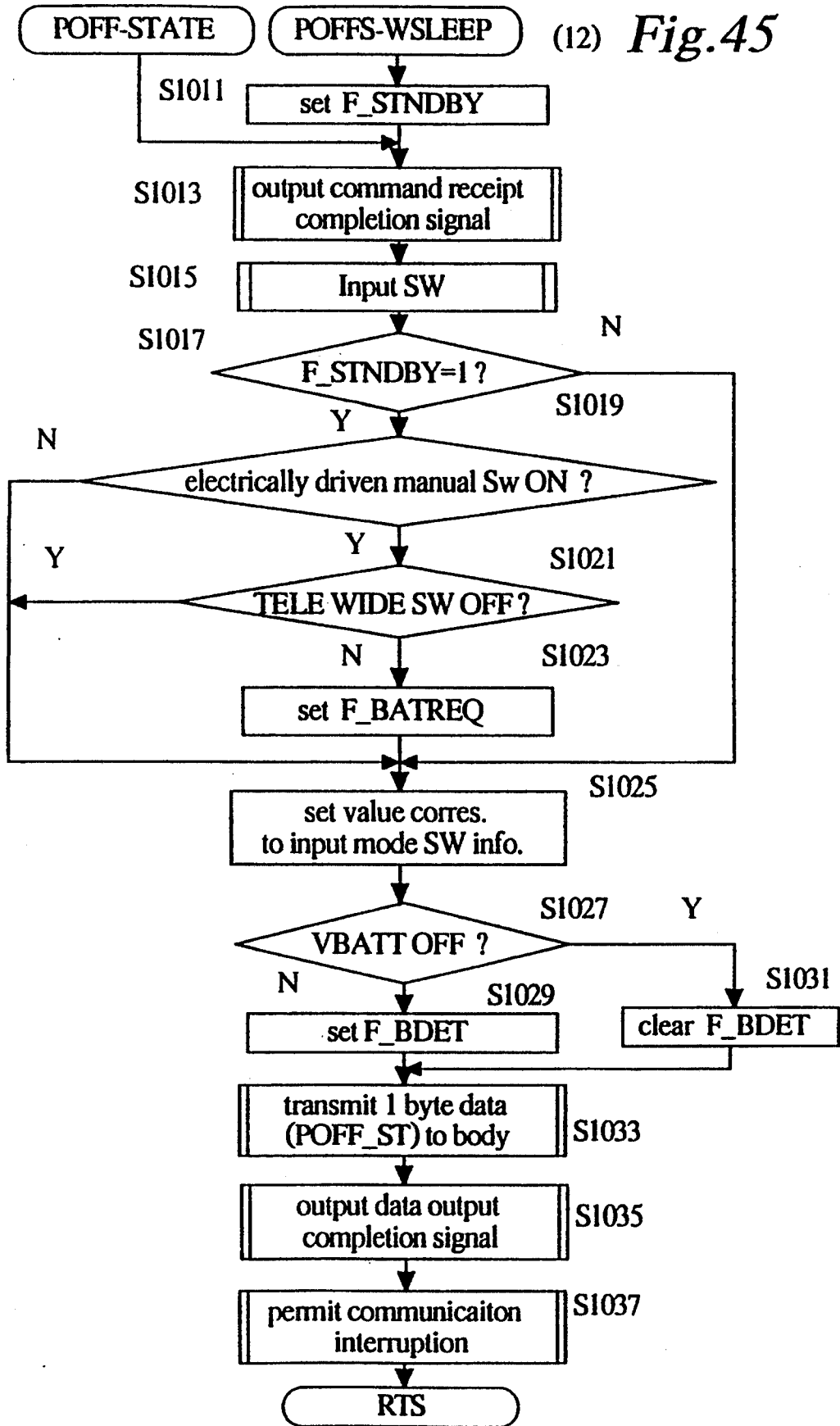

Fig.46

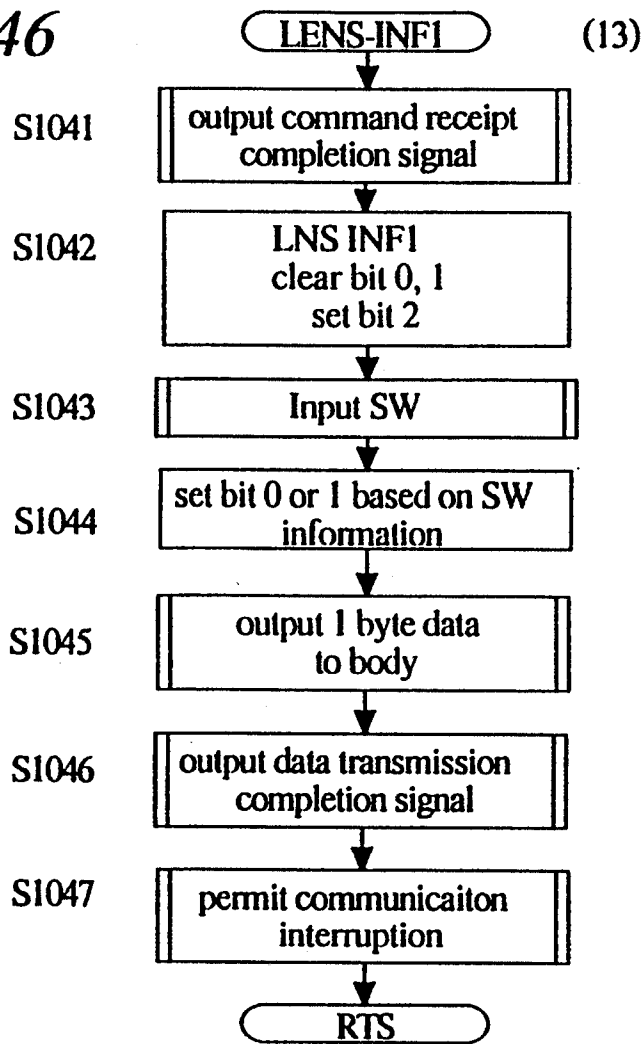

Fig.47

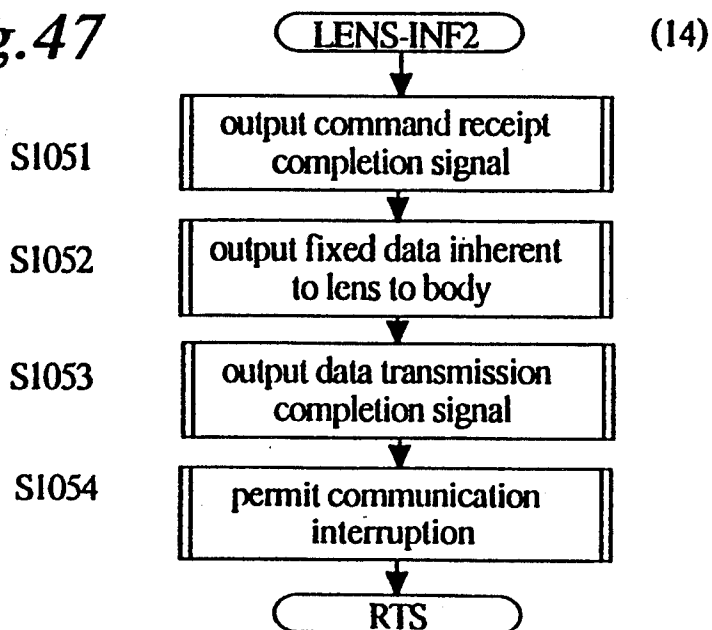

Fig.48

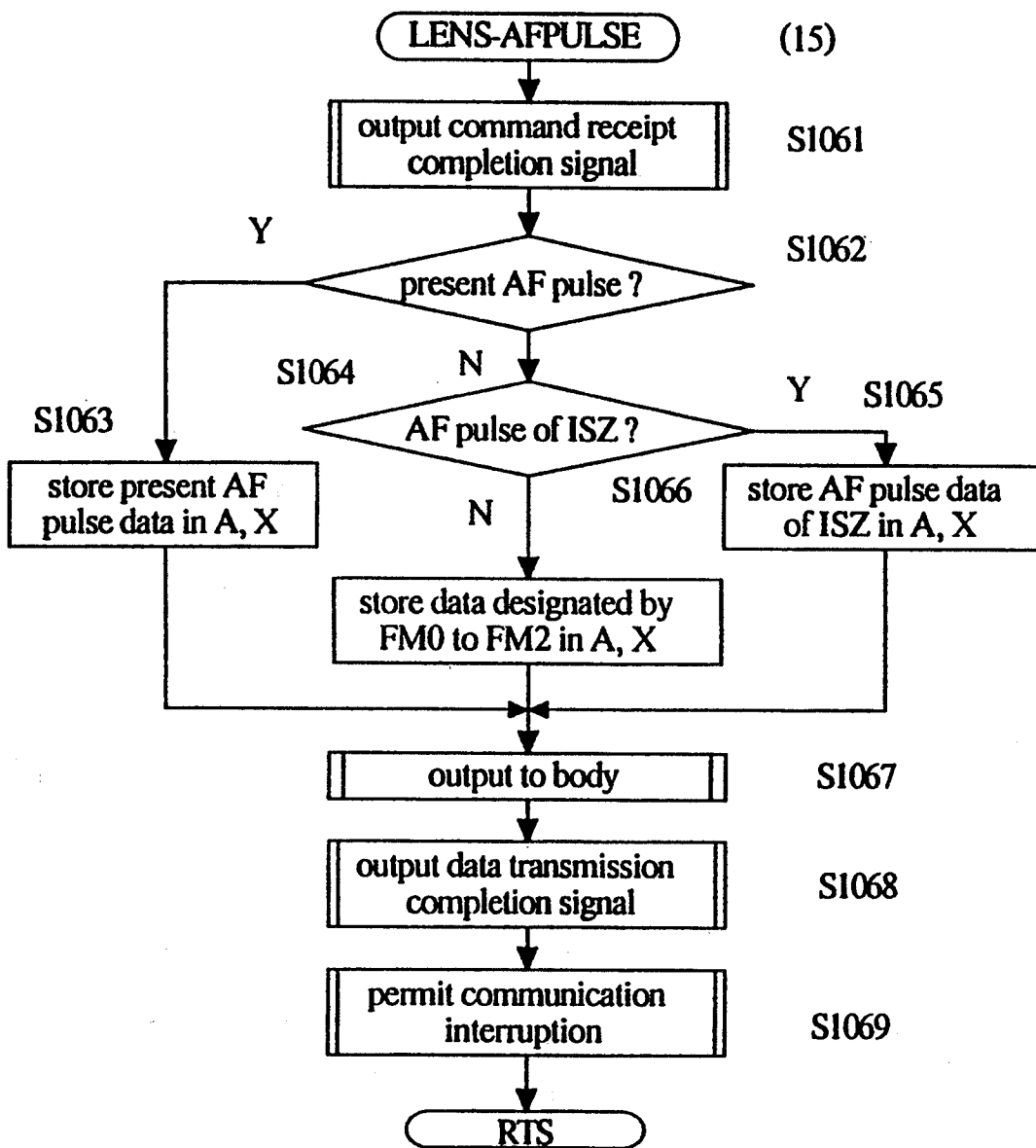

Fig.49

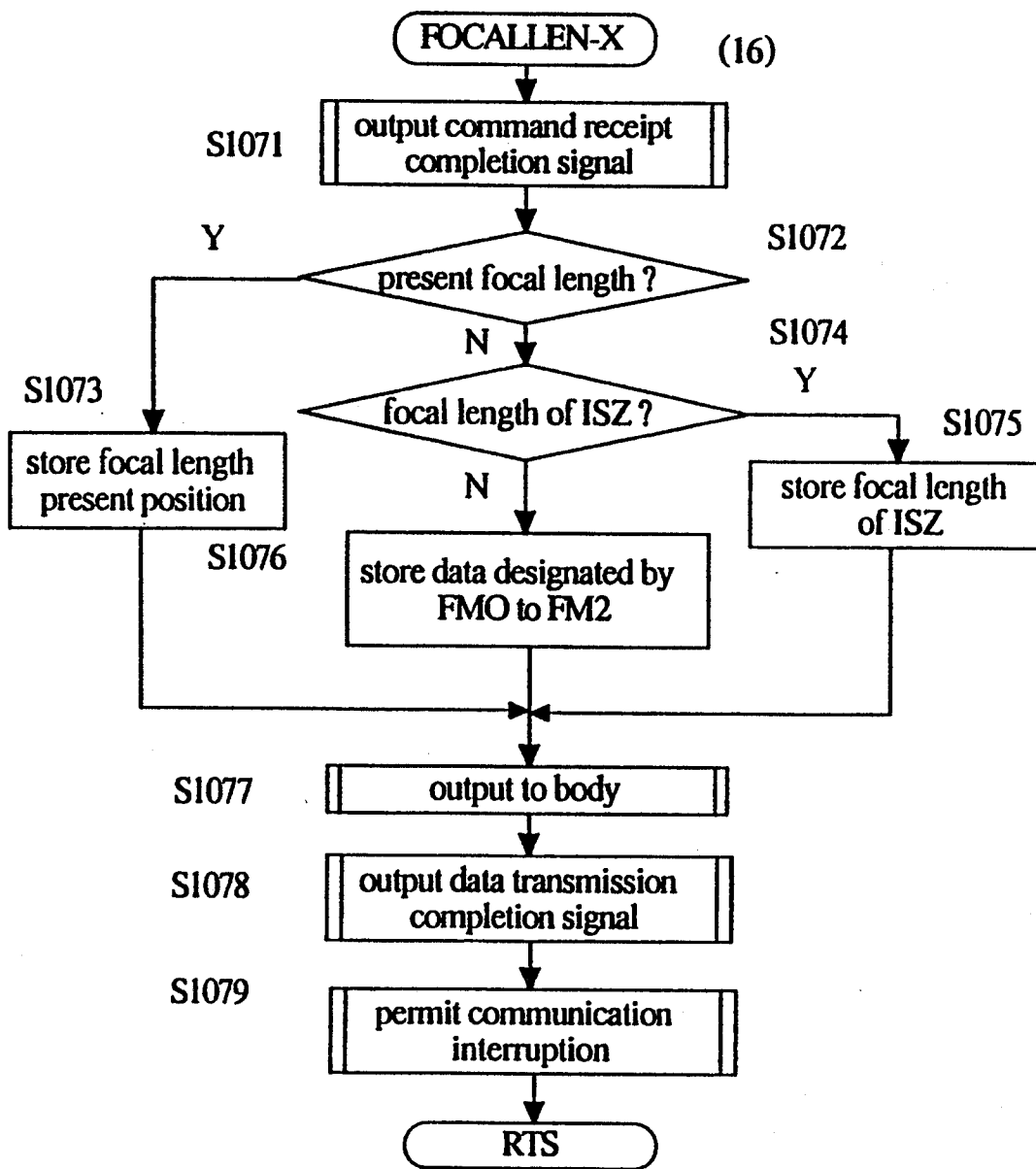

Fig. 50

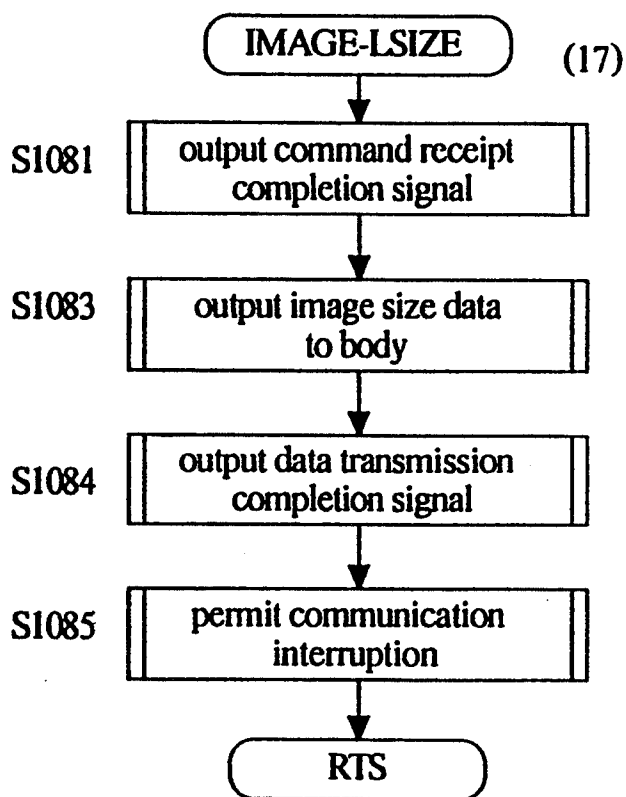

Fig. 51

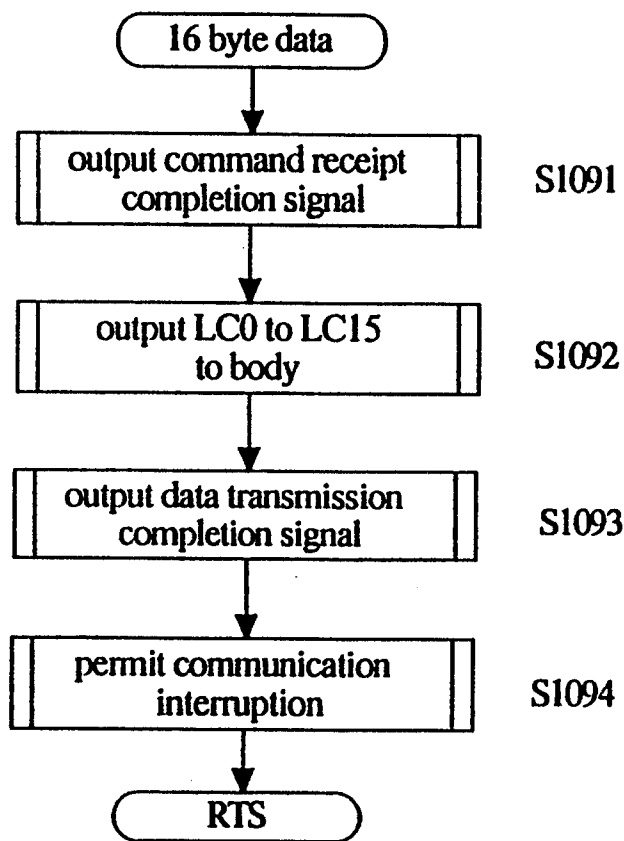

Fig.52

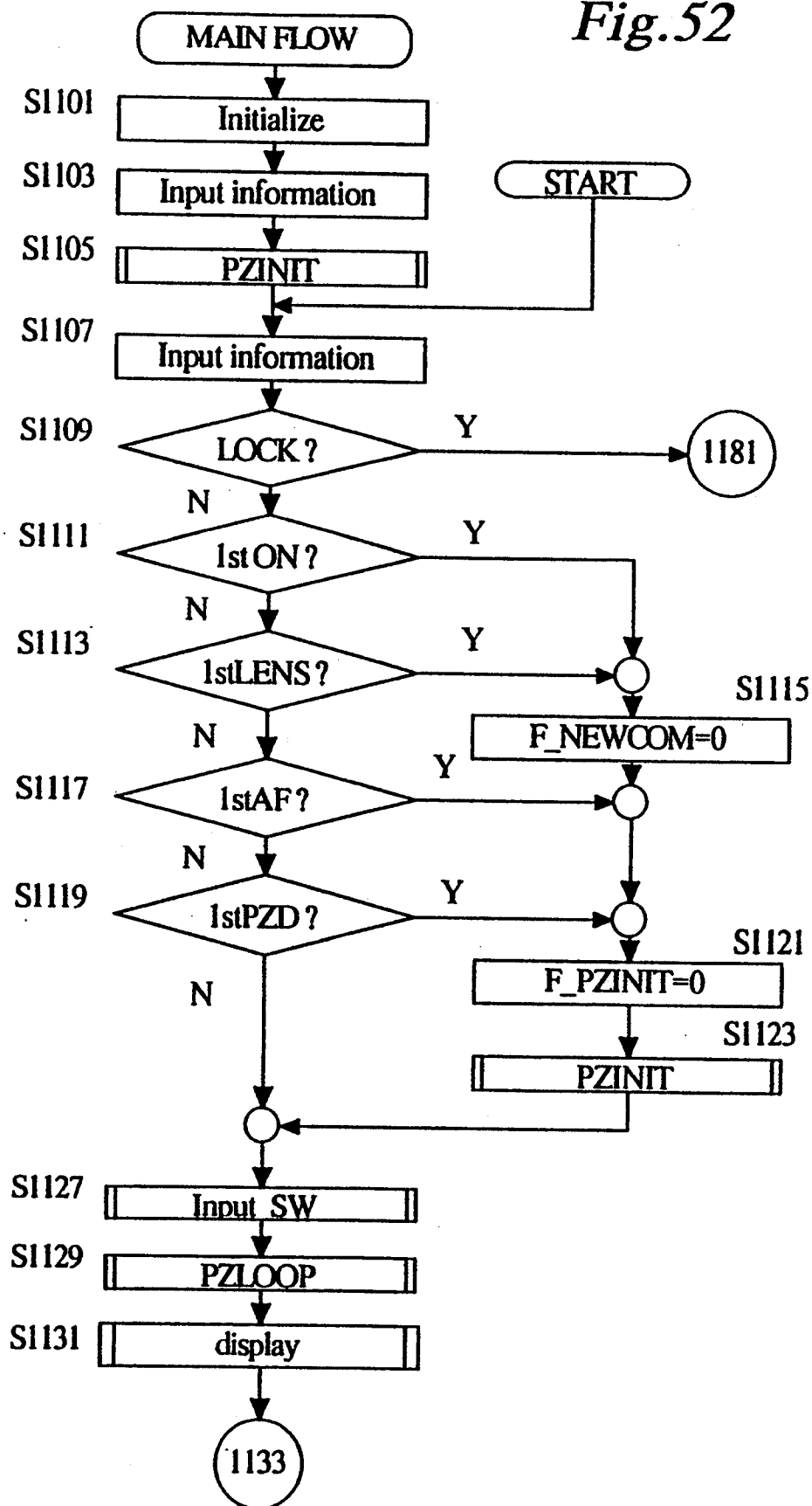

Fig. 53

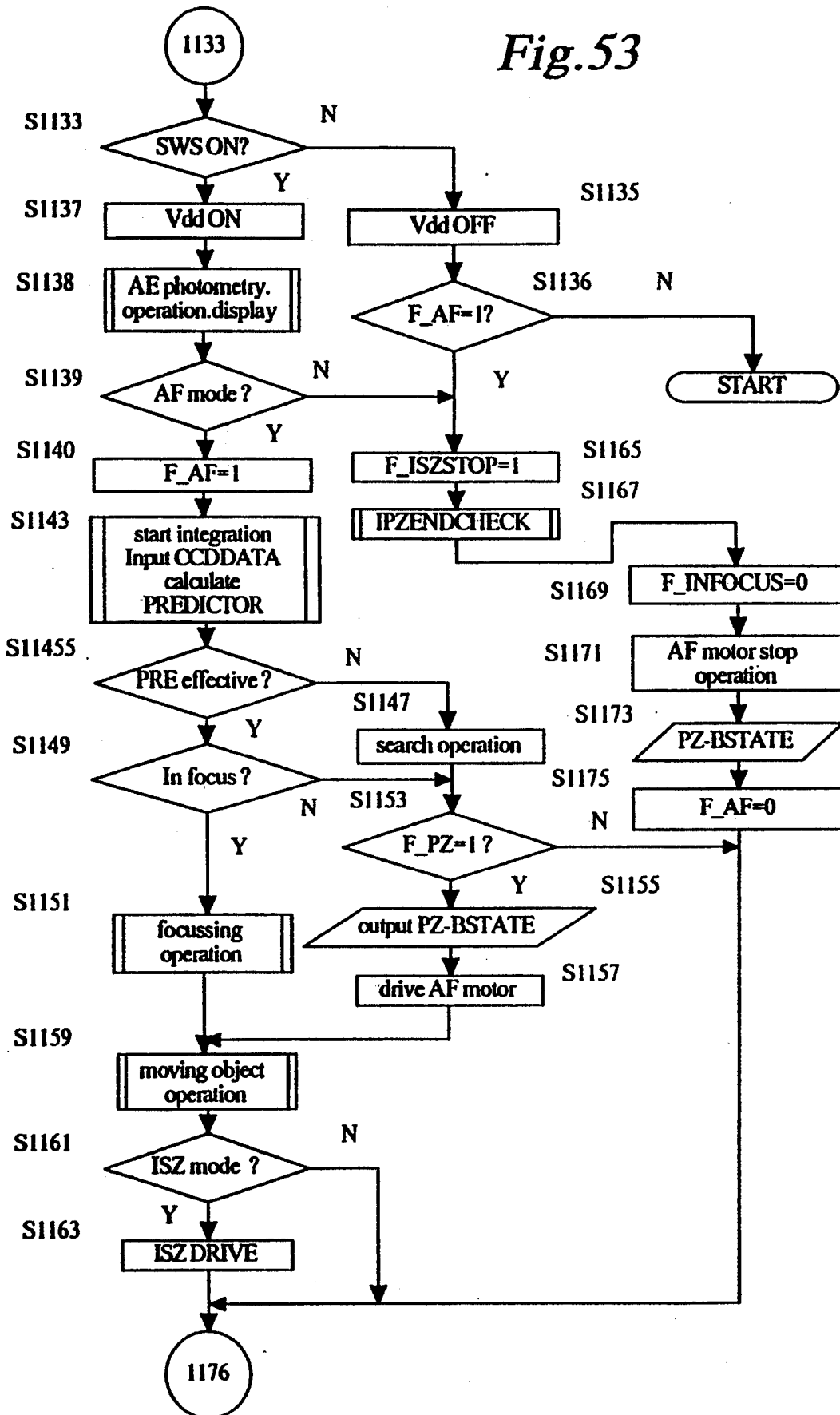

Fig. 54

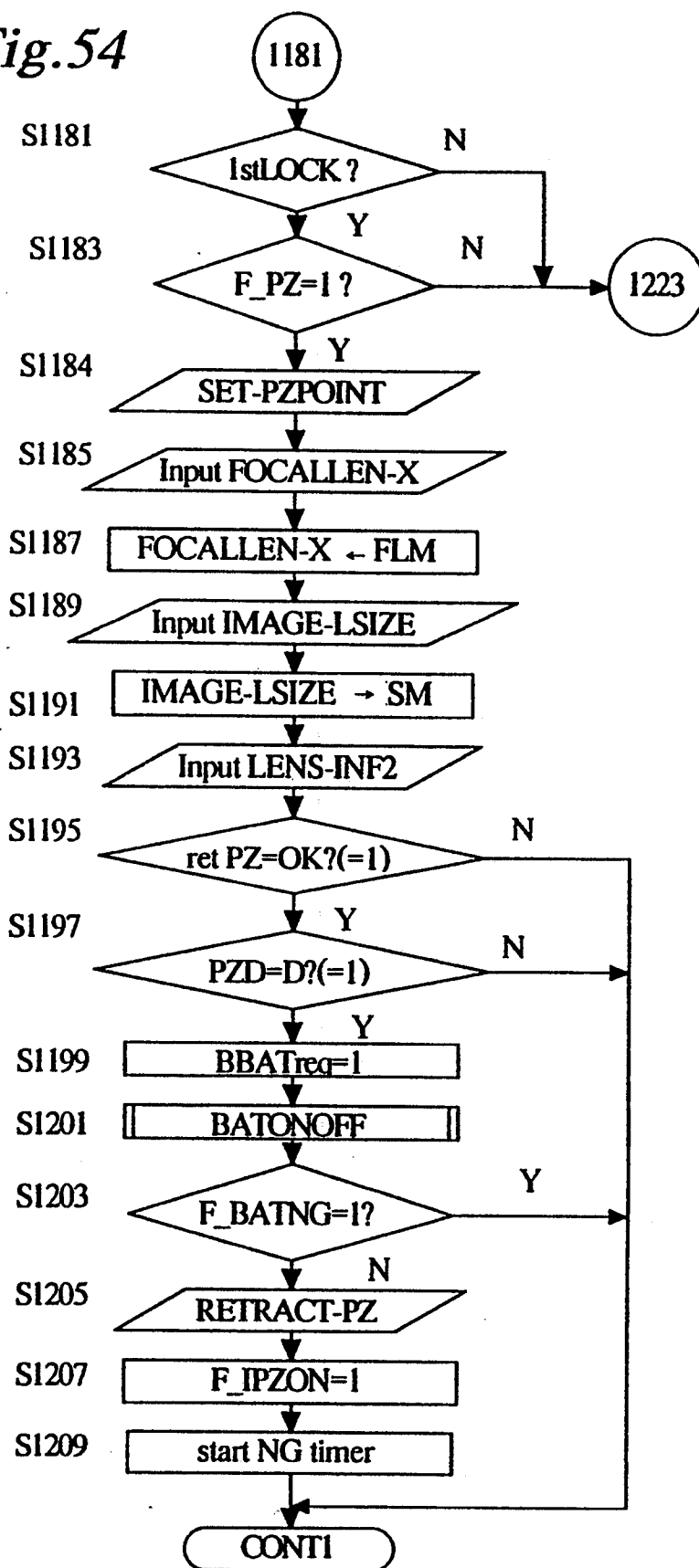

Fig.55

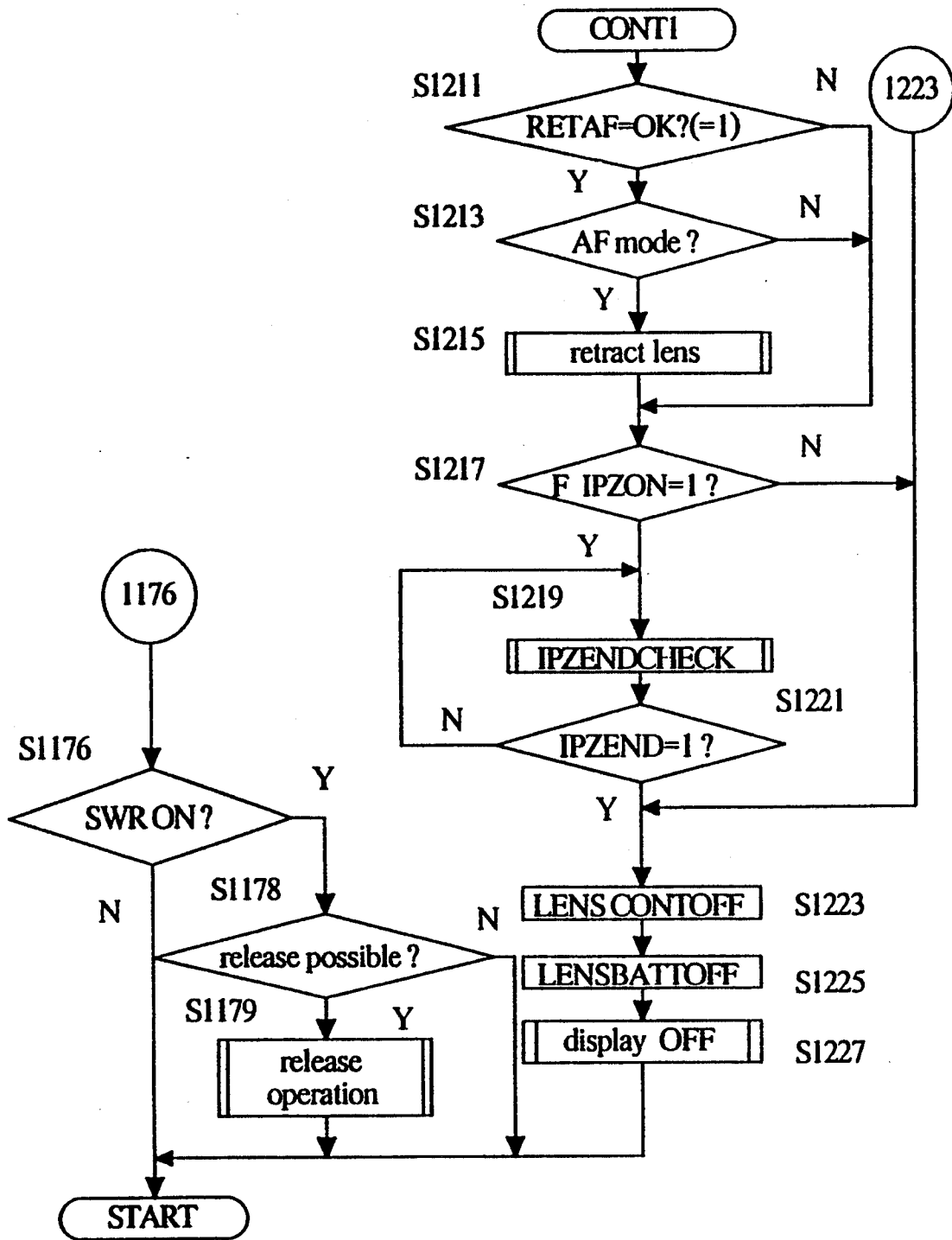

Fig.56

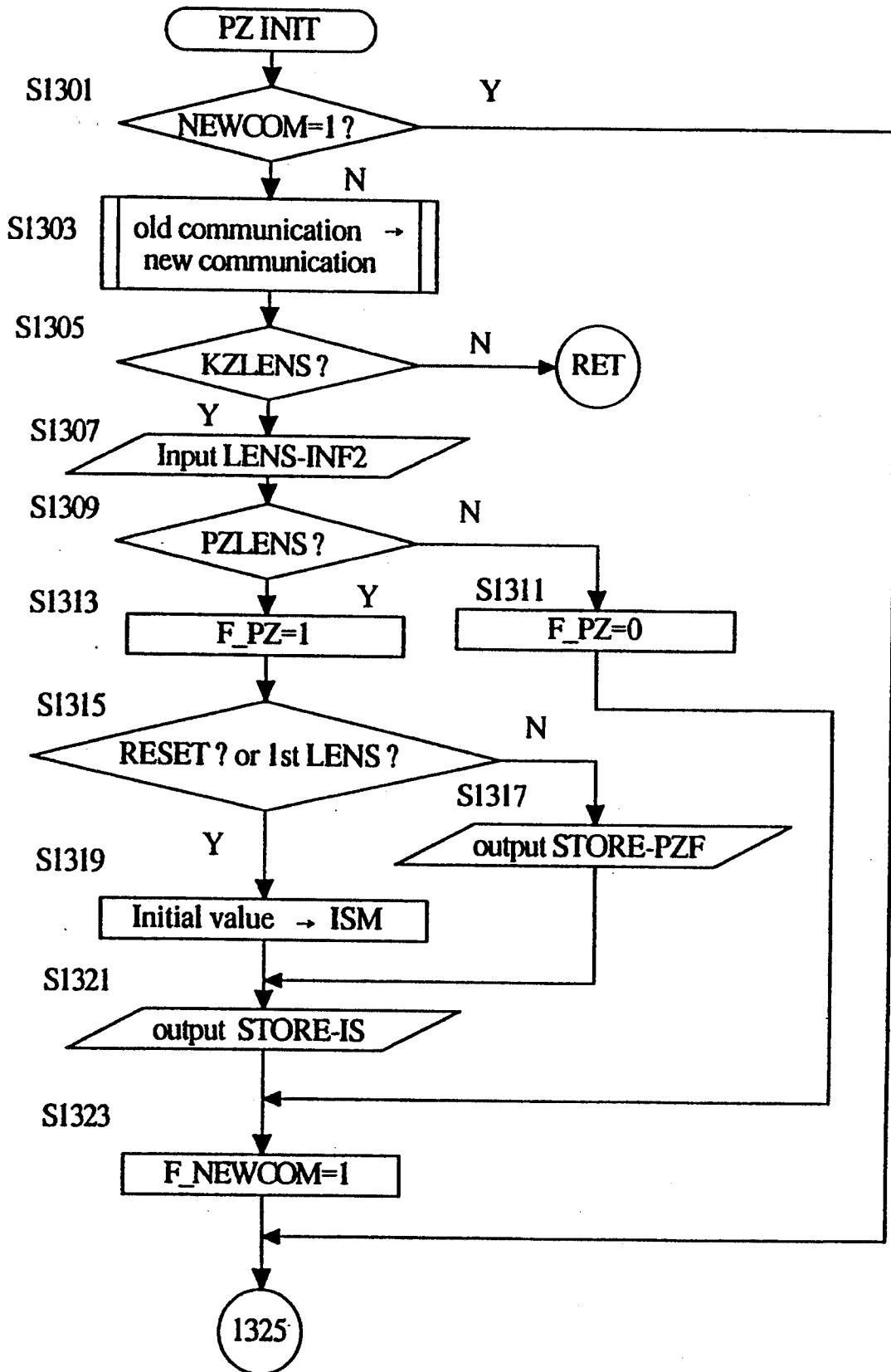

Fig.57

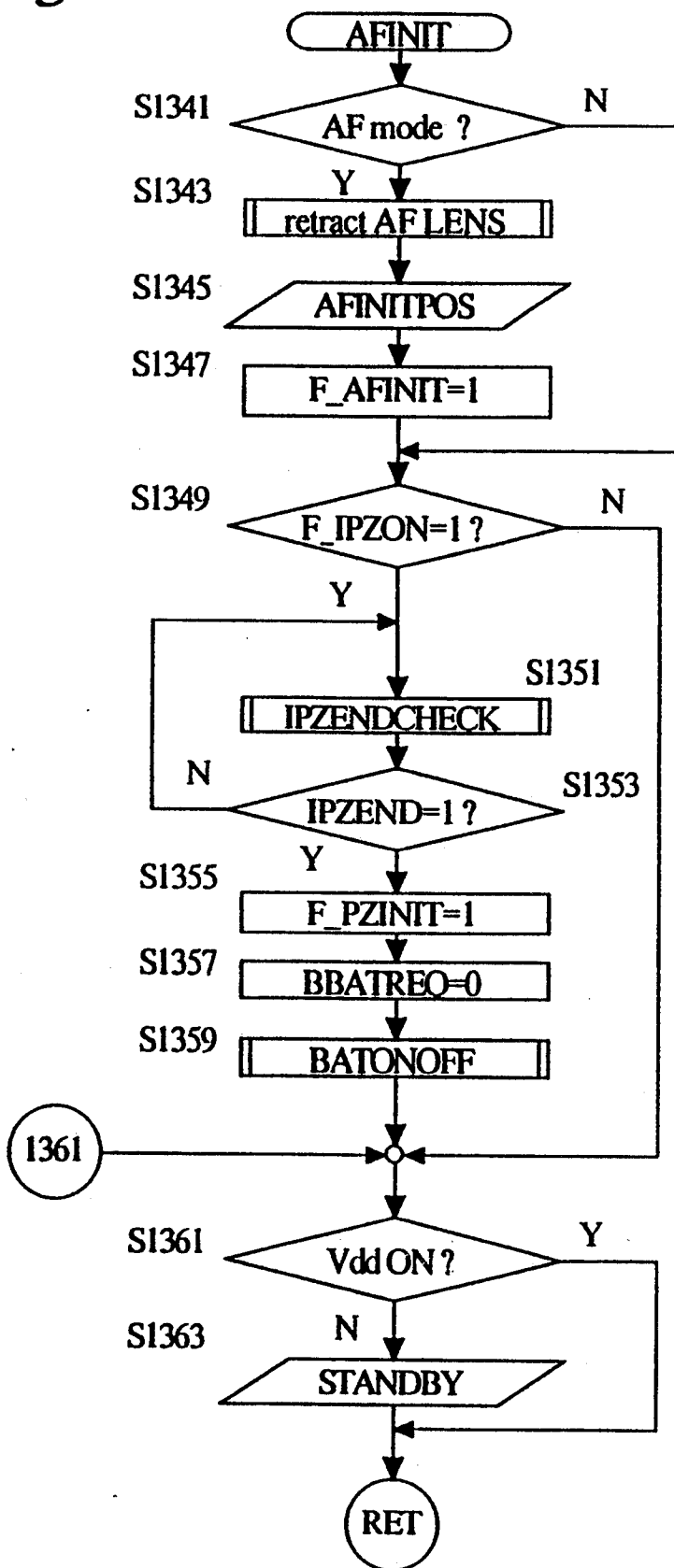

Fig.58

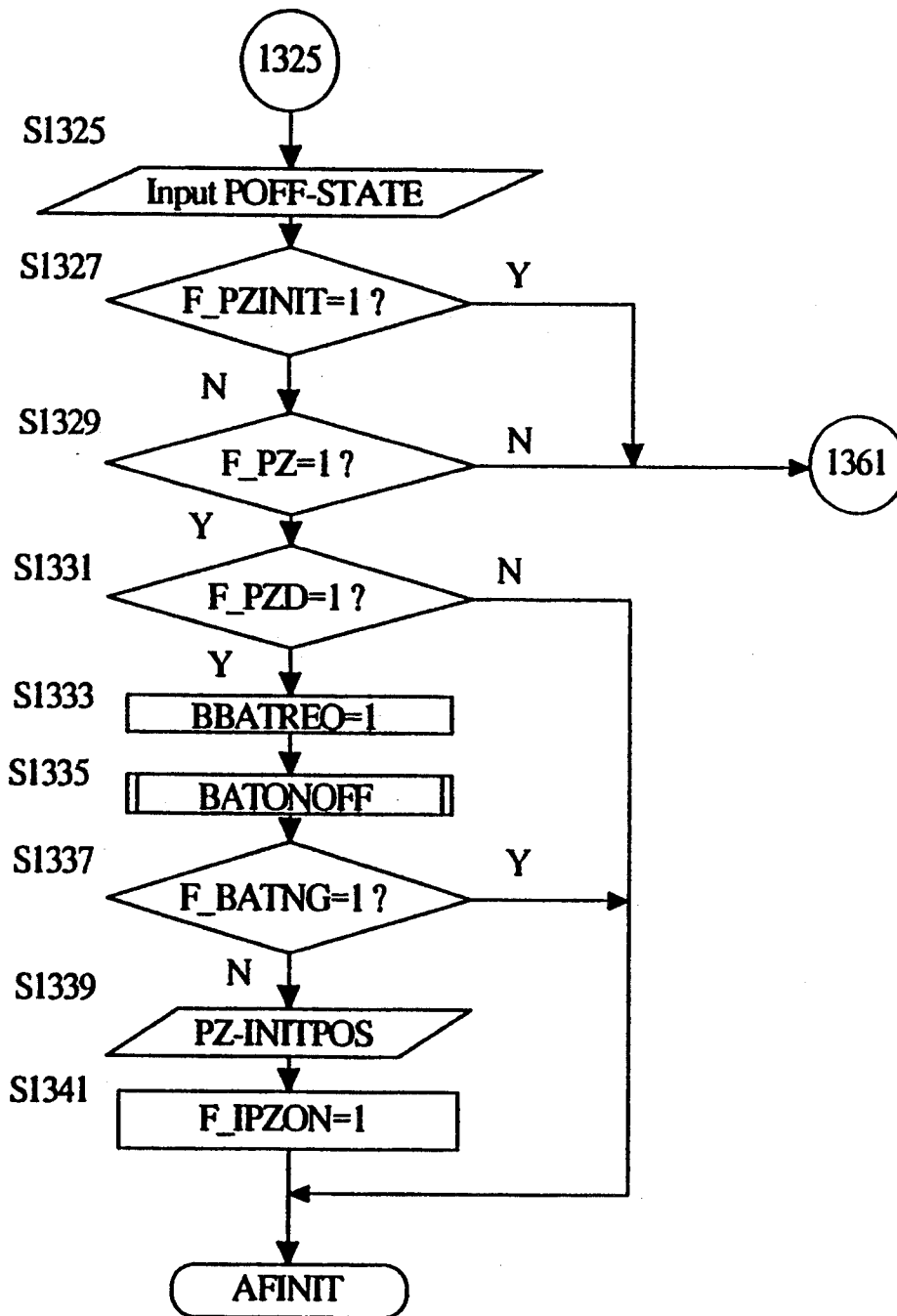

Fig. 59

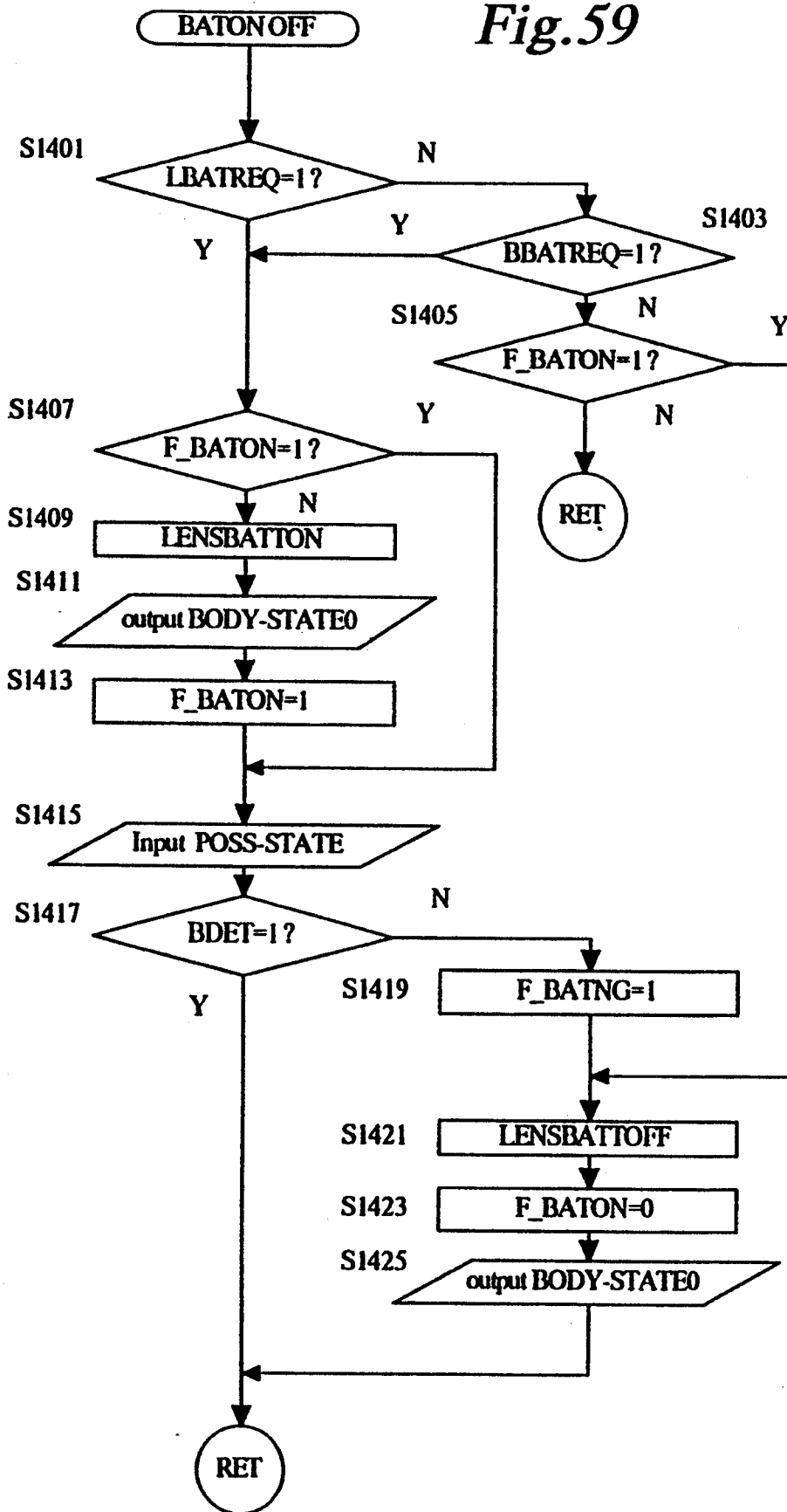

Fig. 60A

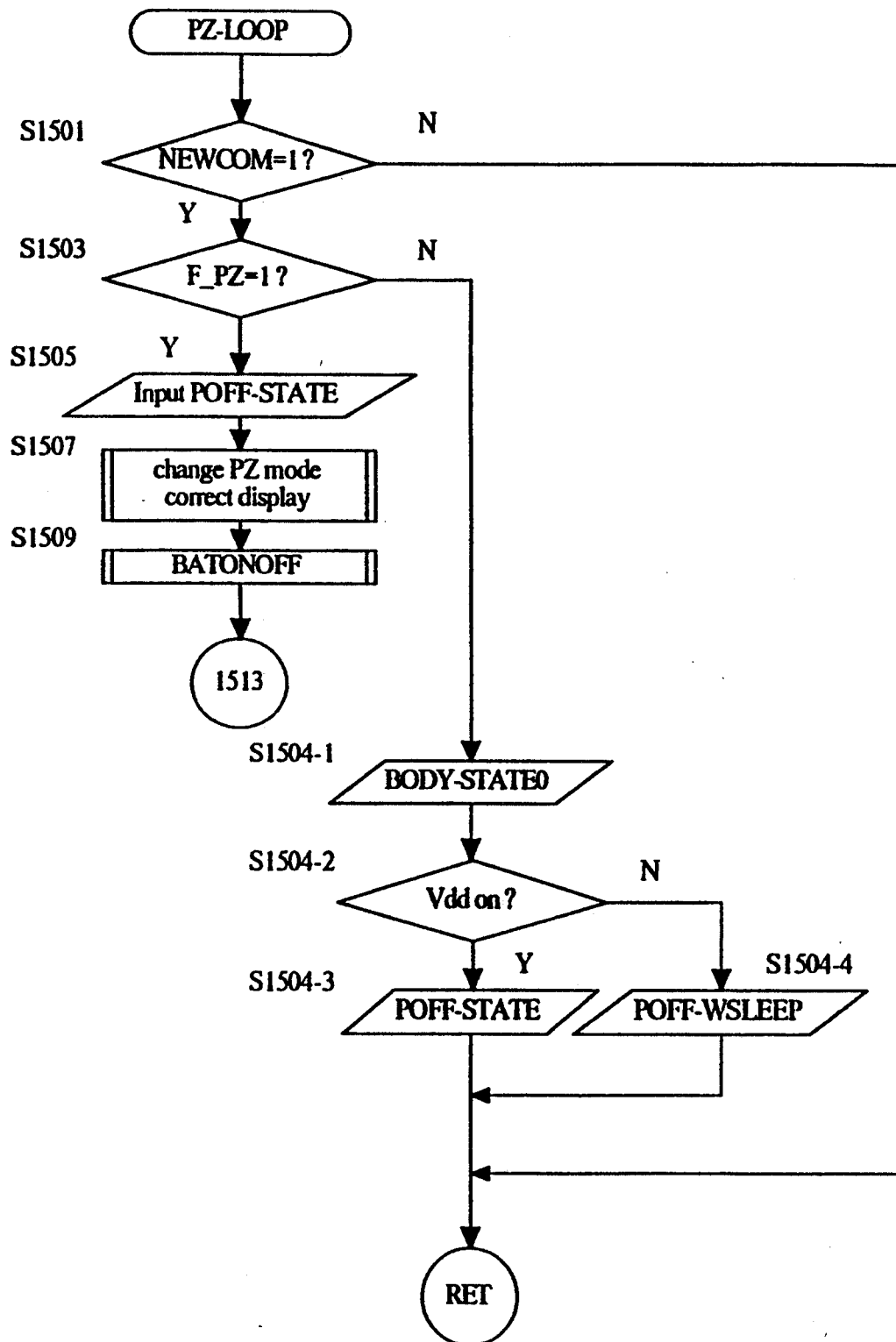

Fig. 60B

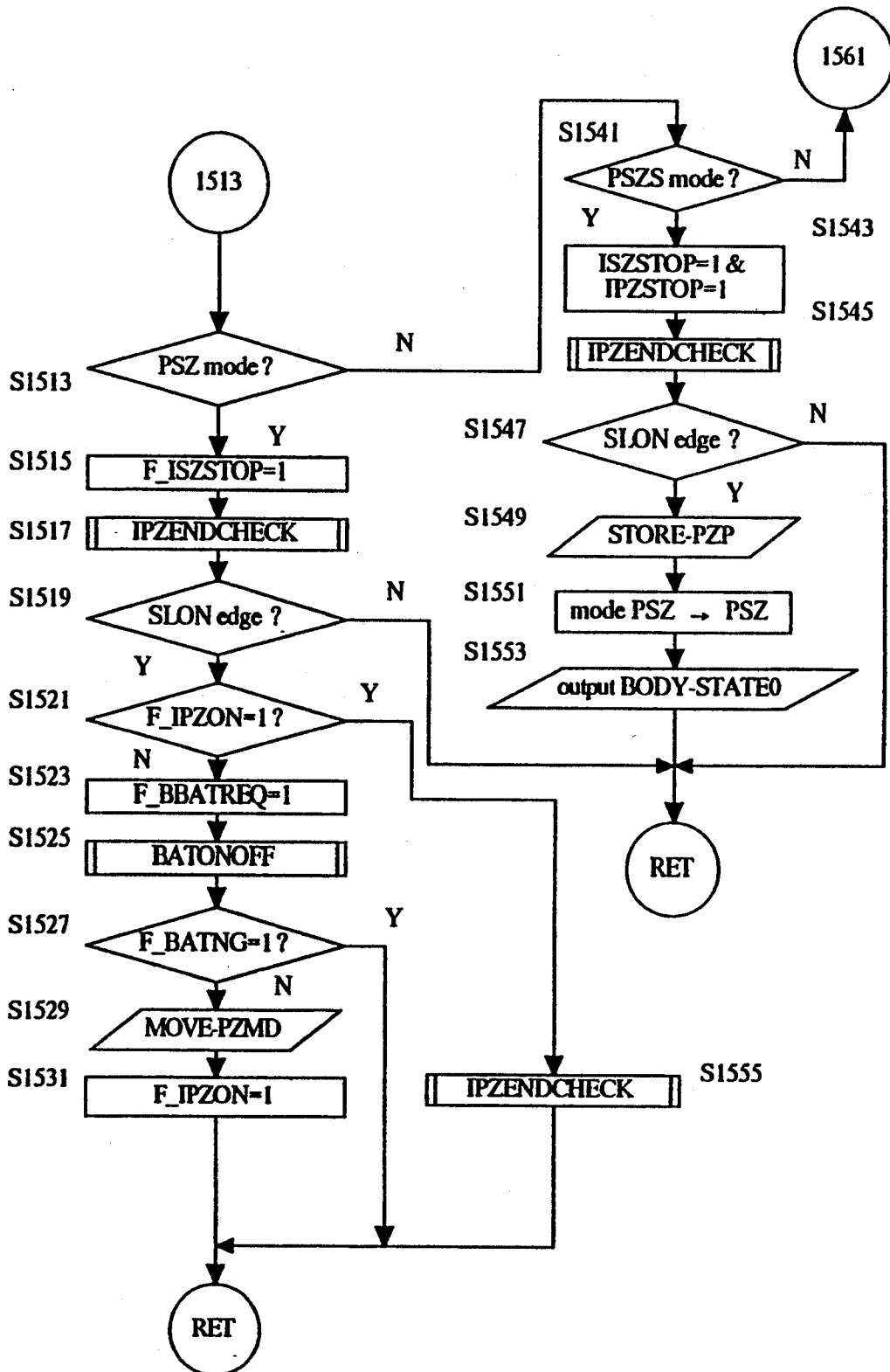

Fig. 61

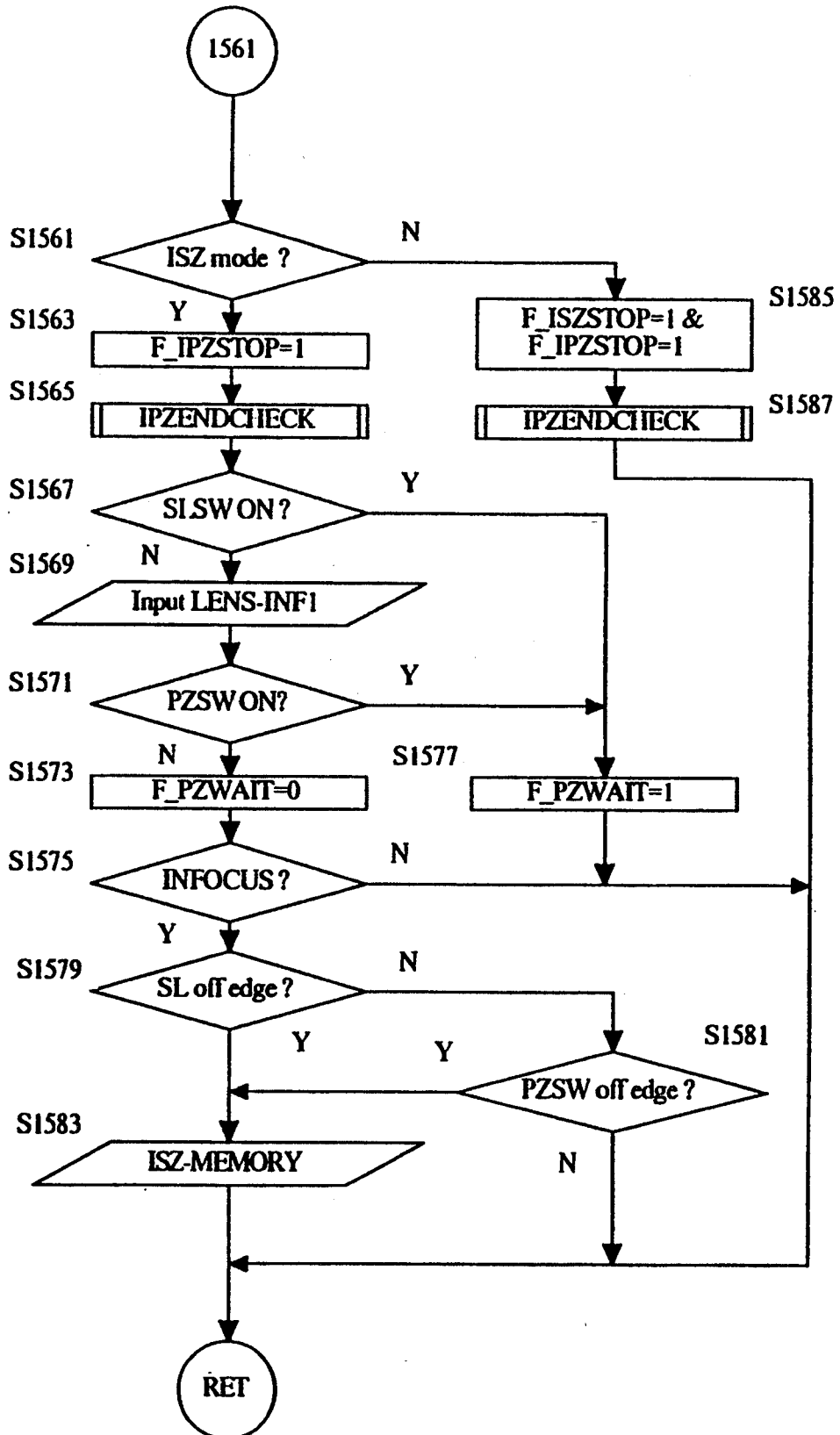

Fig. 62

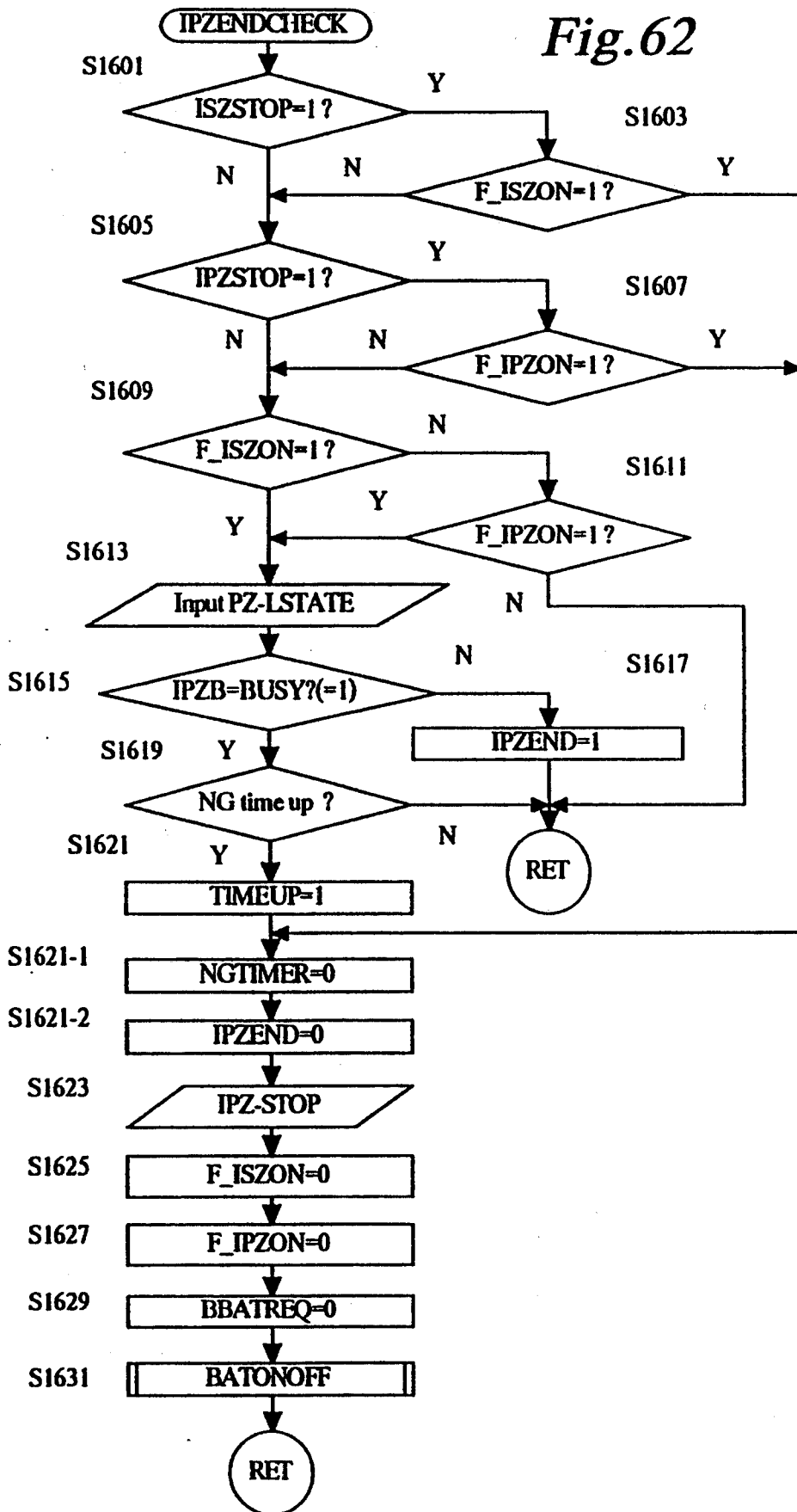

Fig.63

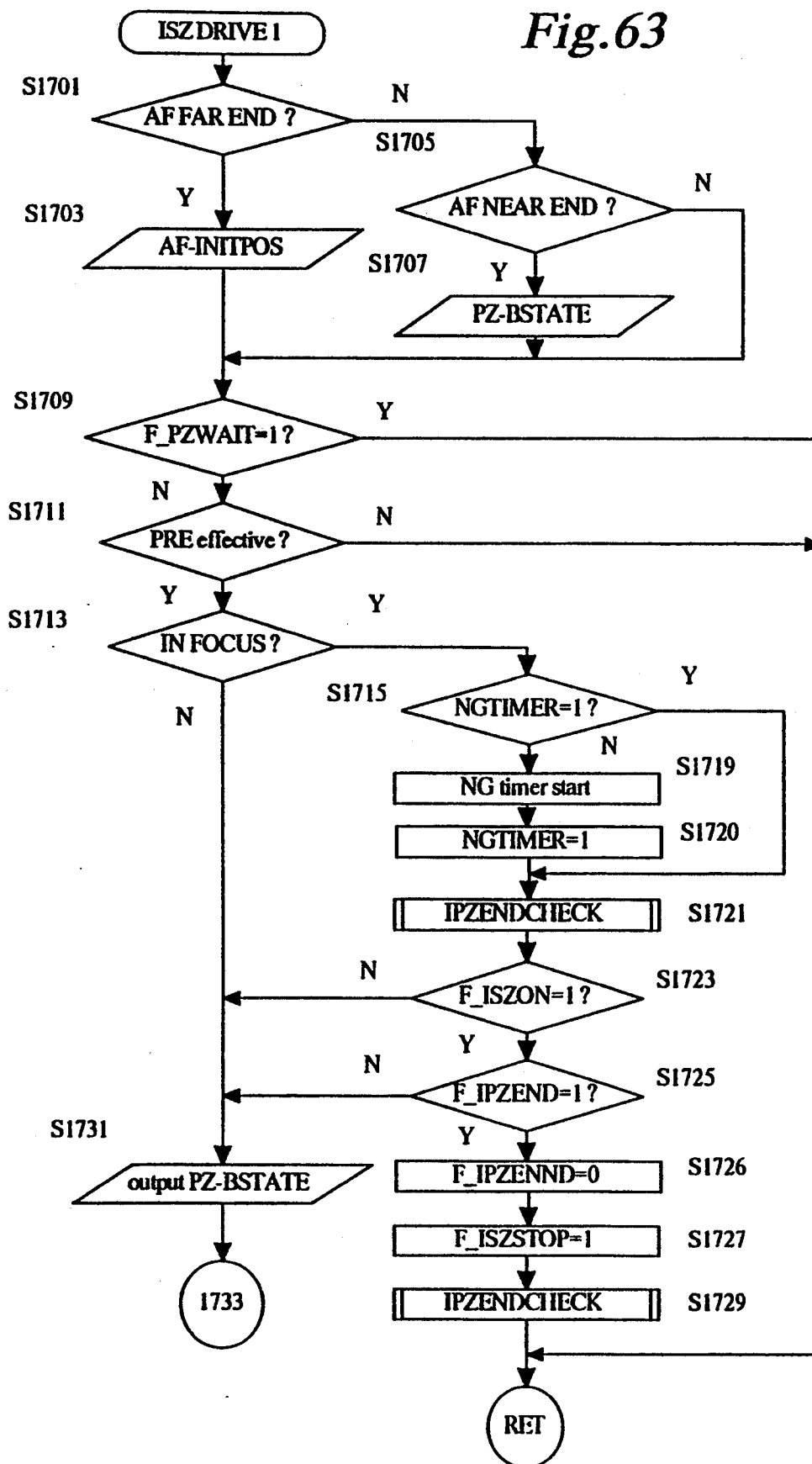

Fig.64

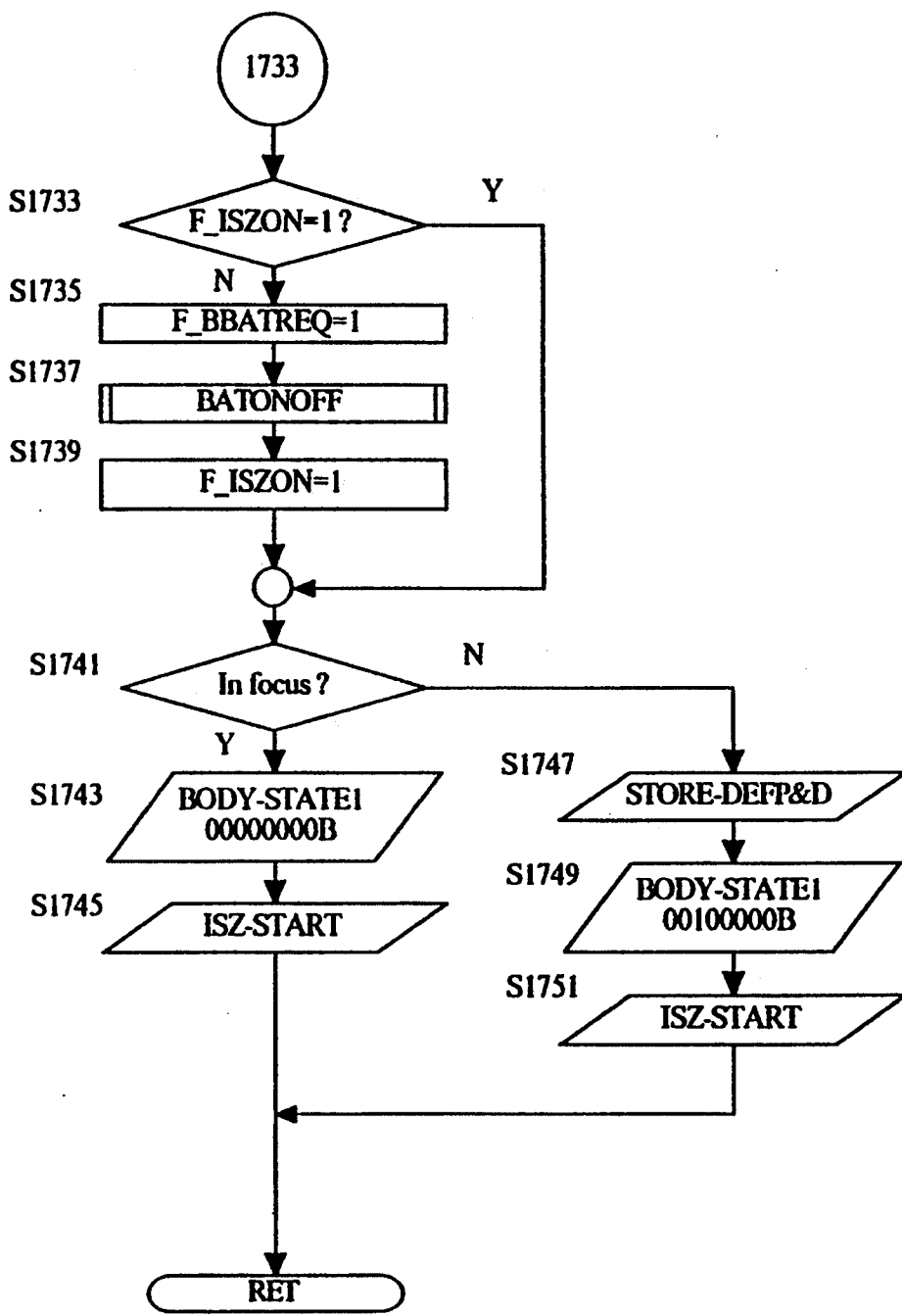

Fig. 65

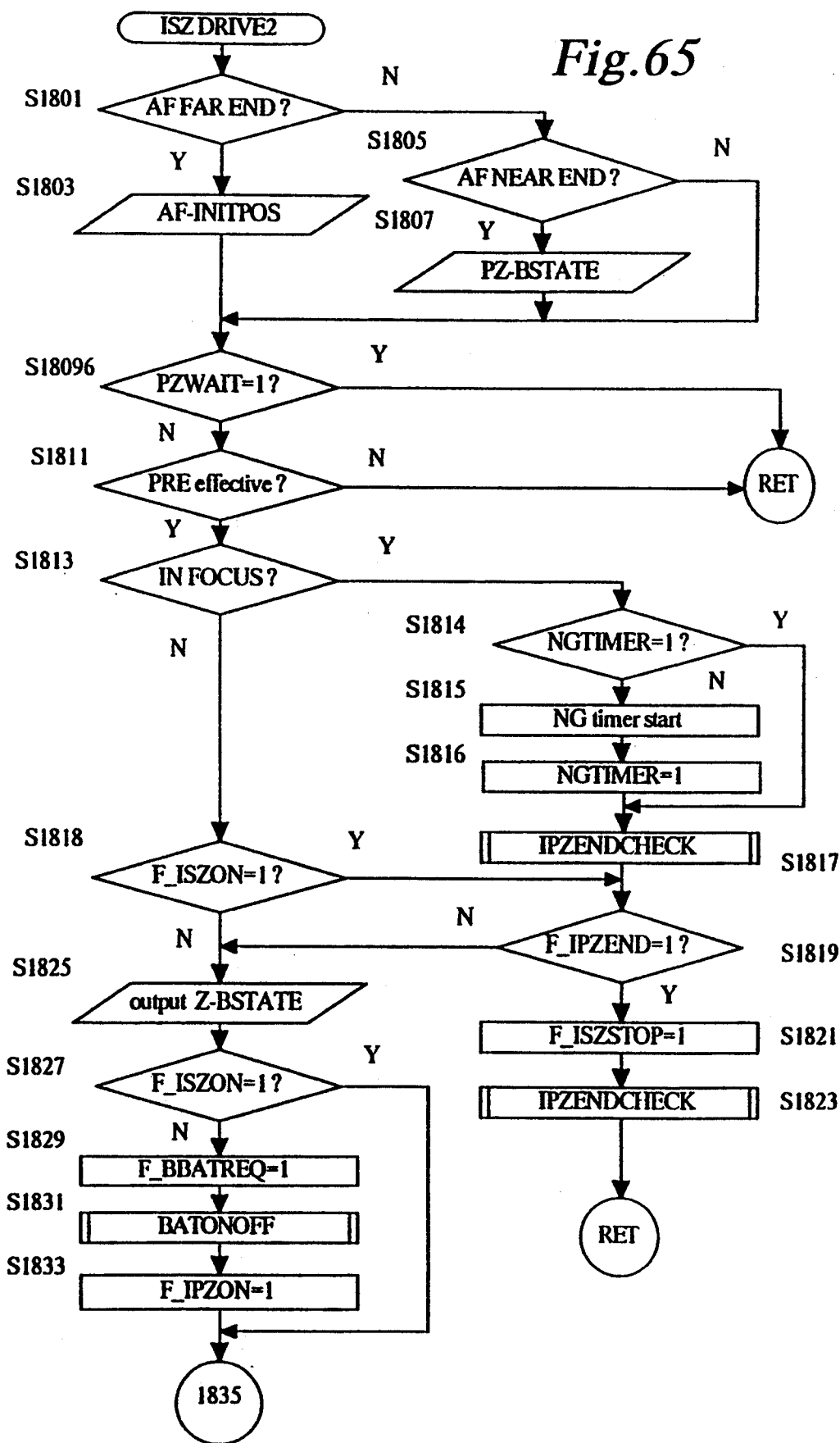

Fig. 66

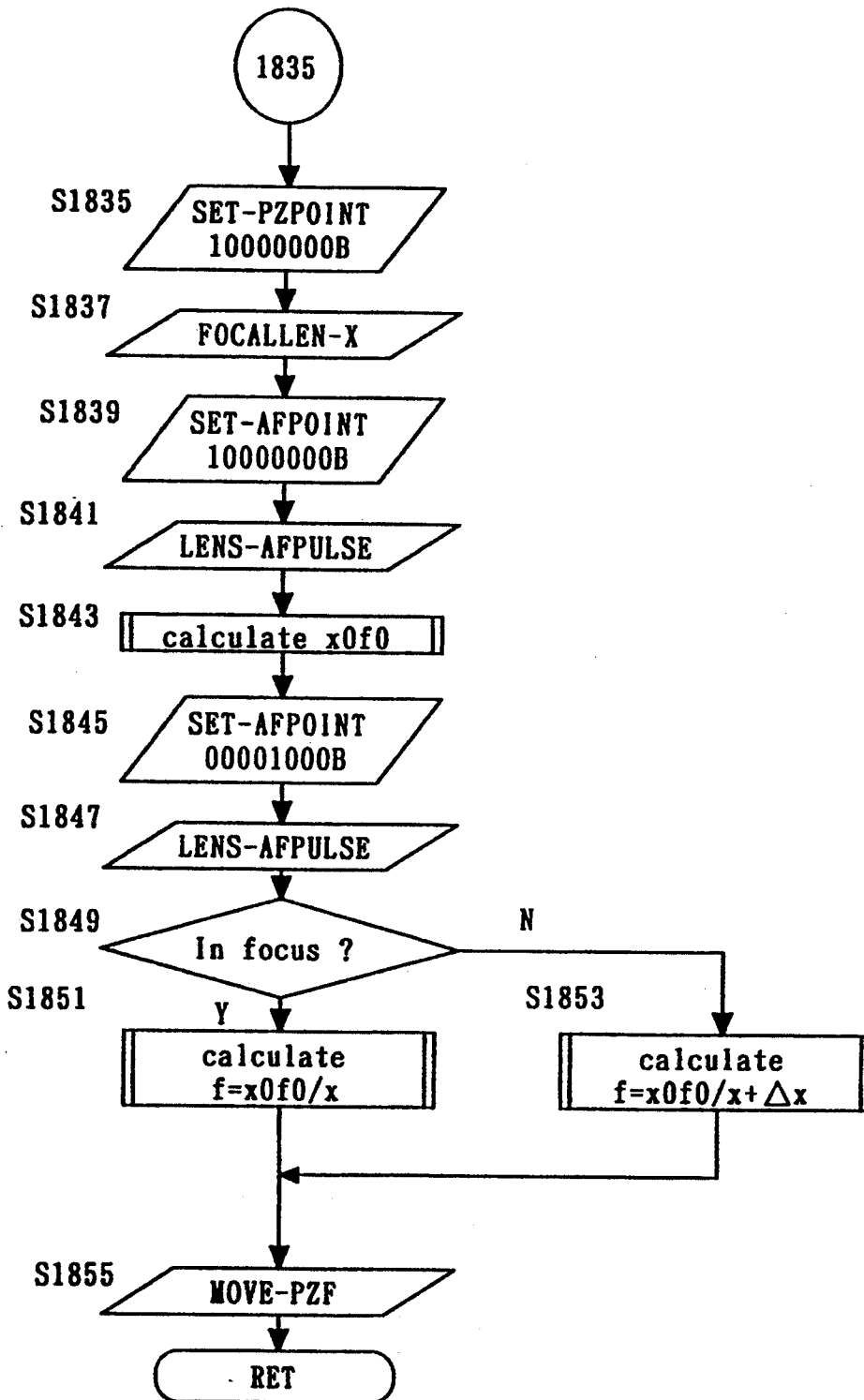

Fig. 67

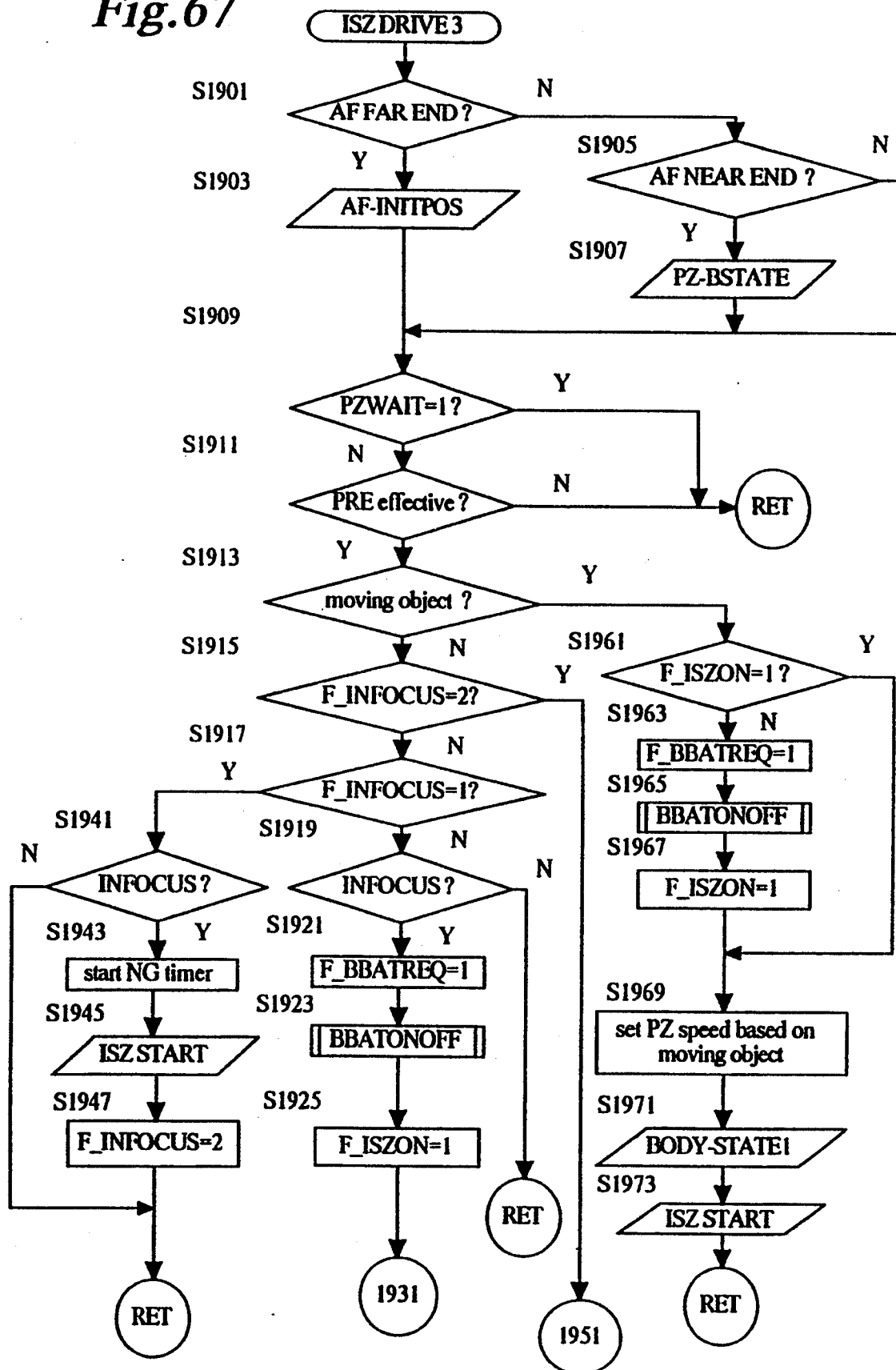

Fig.68

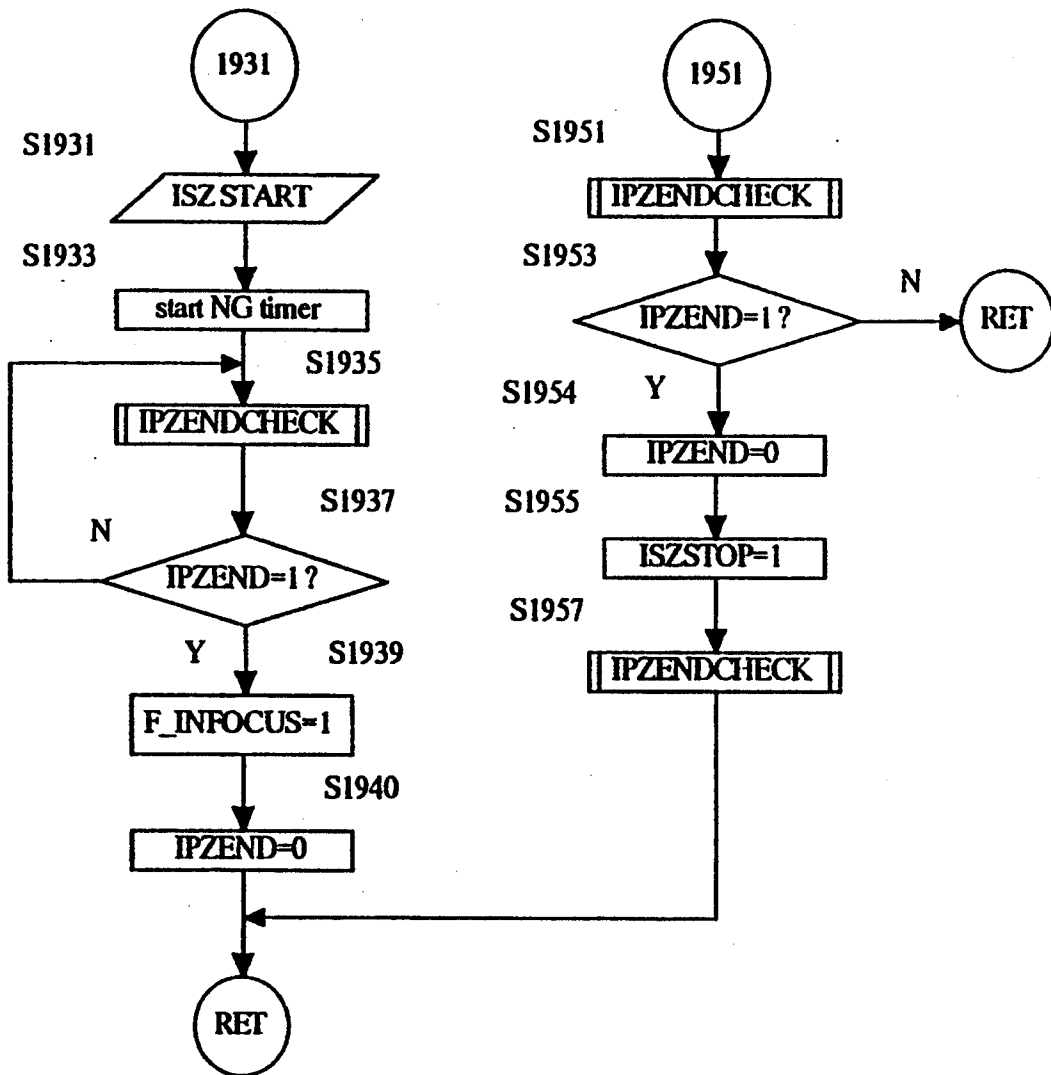

Fig.69

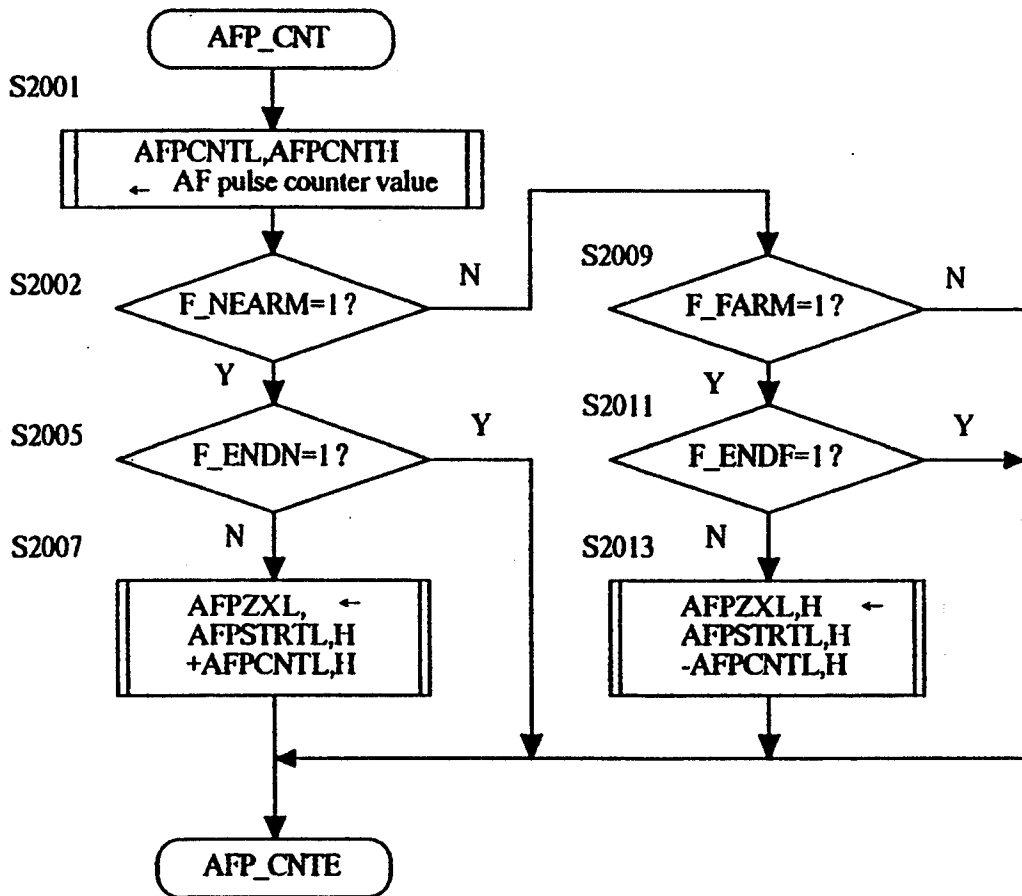

Fig. 70

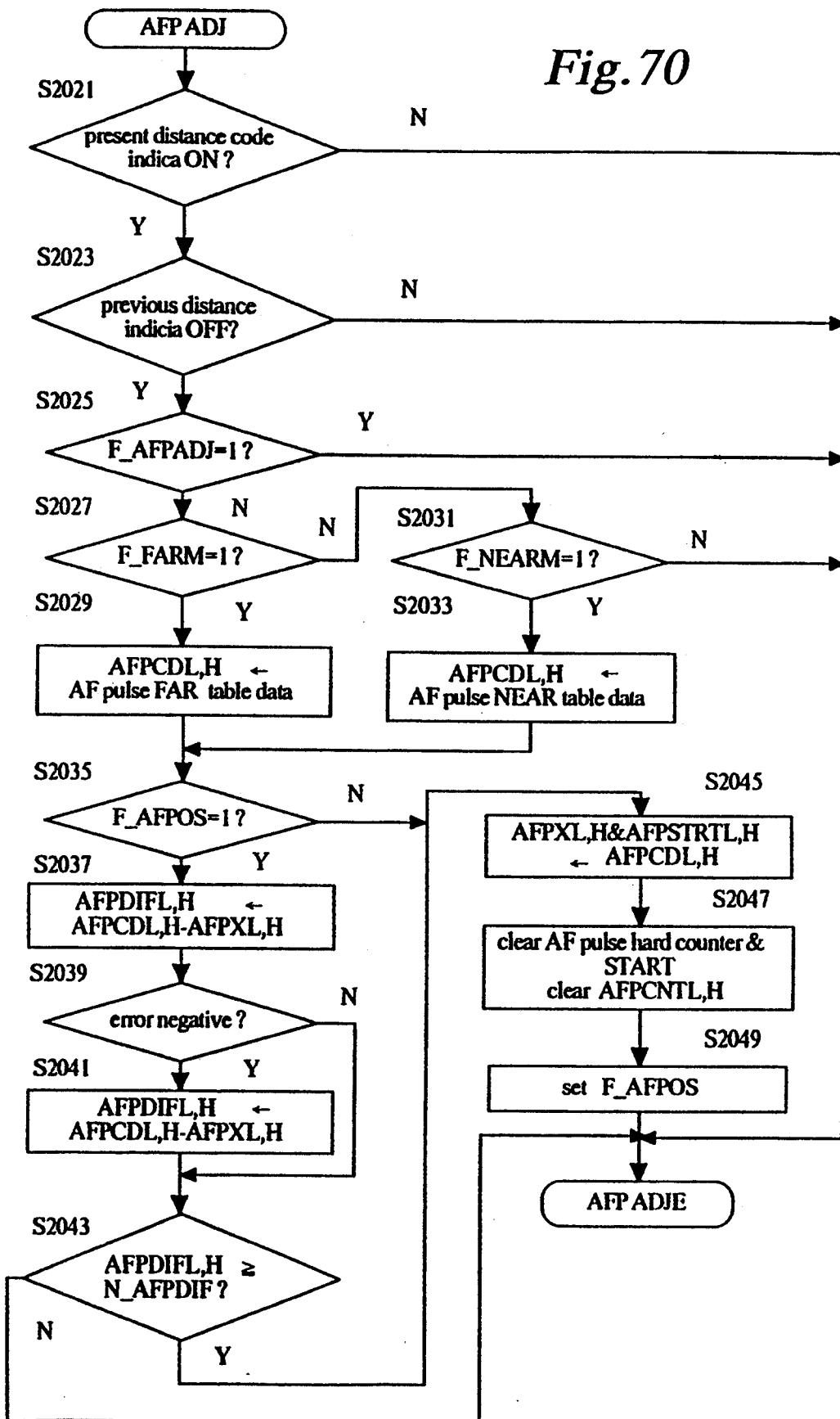

Fig. 71

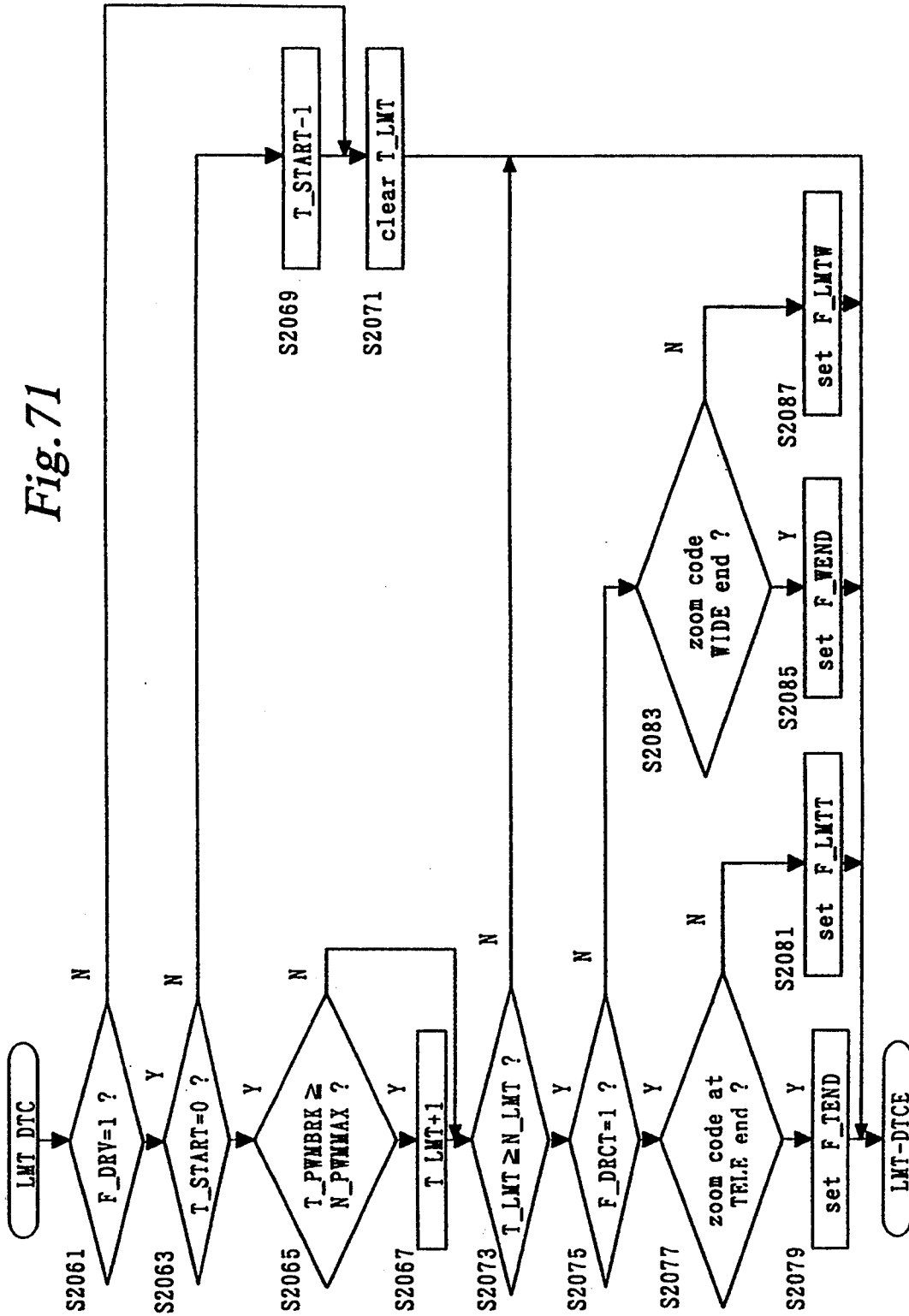

Fig. 72

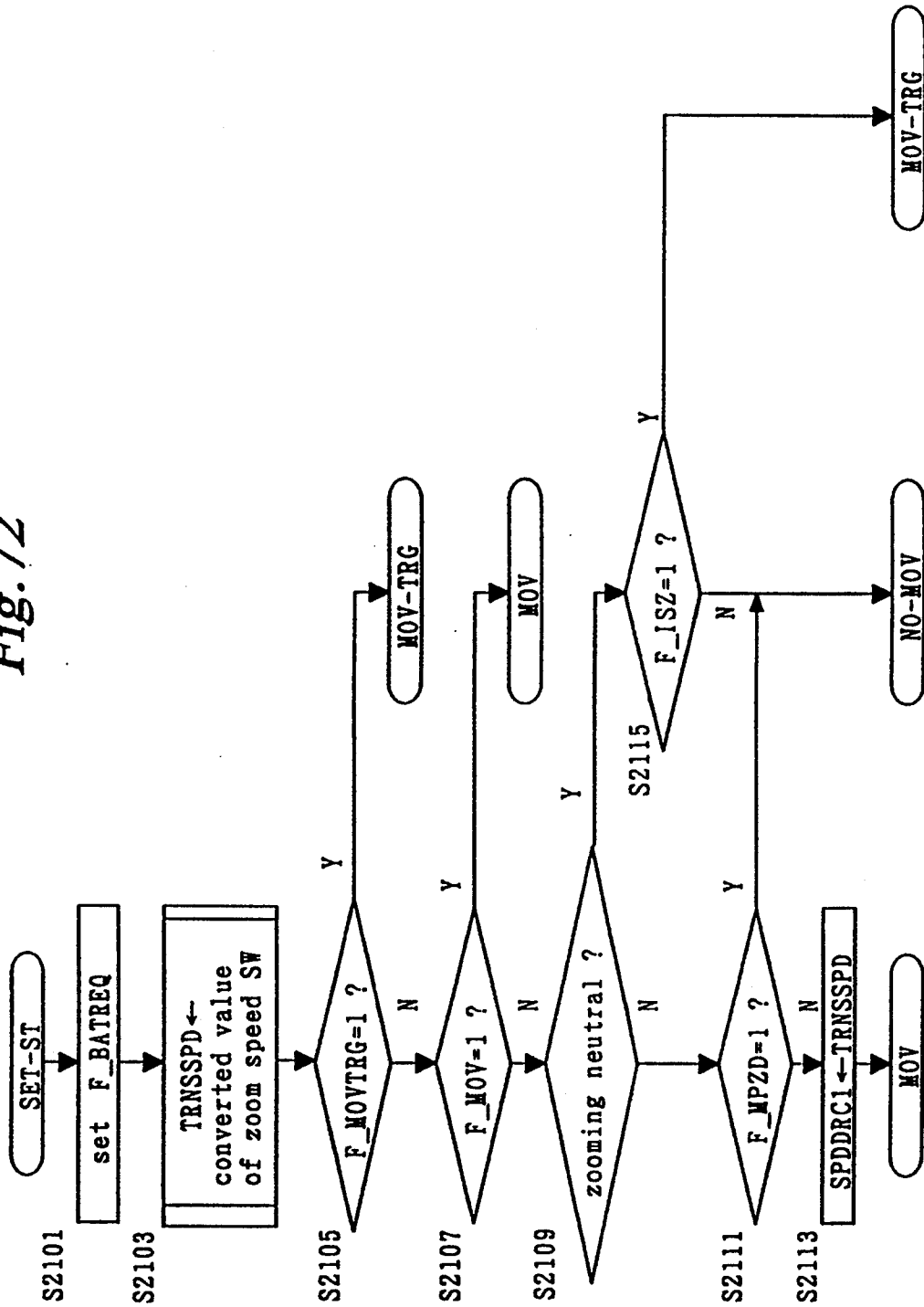

FIG. 73

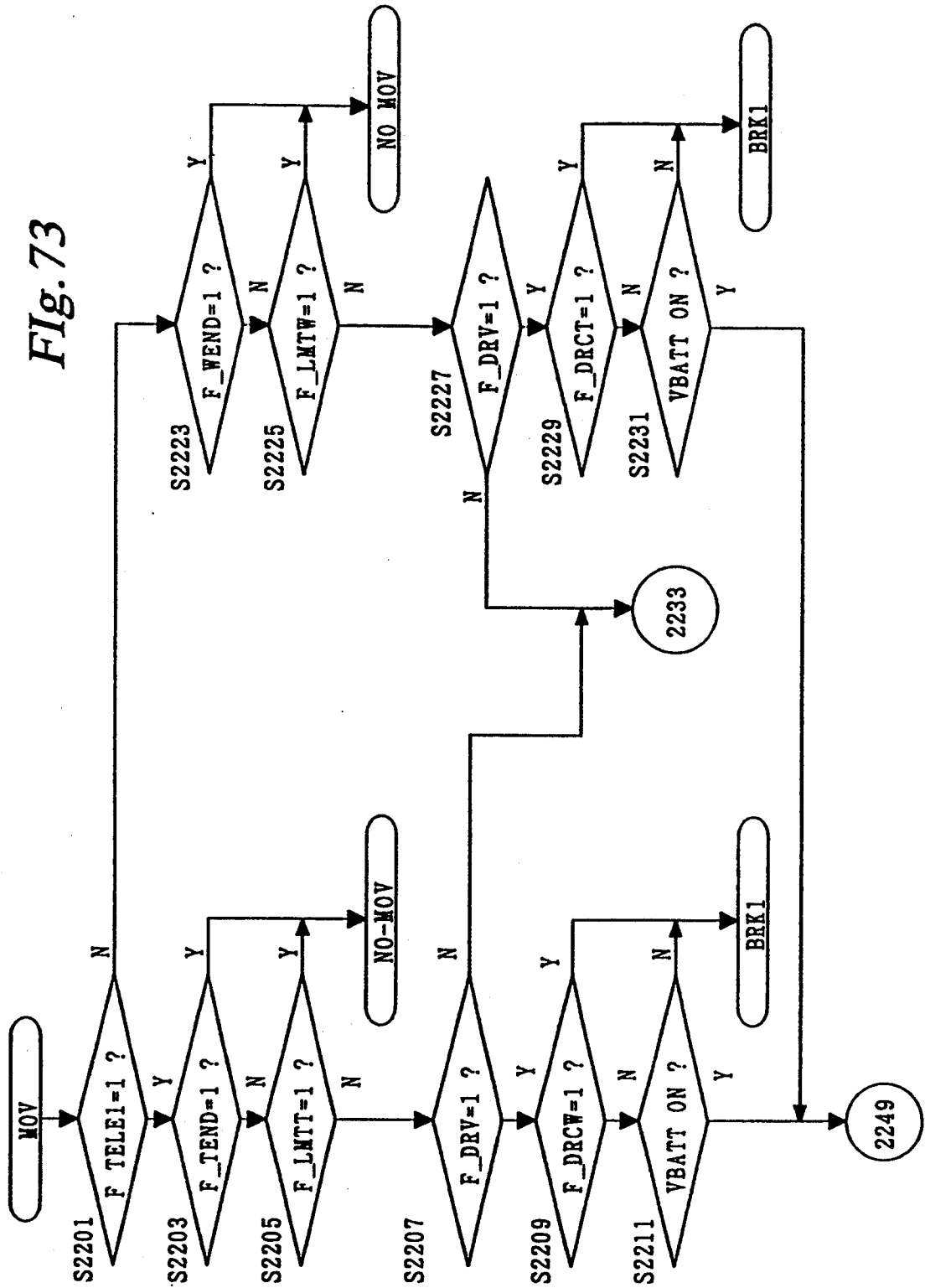

Fig. 74

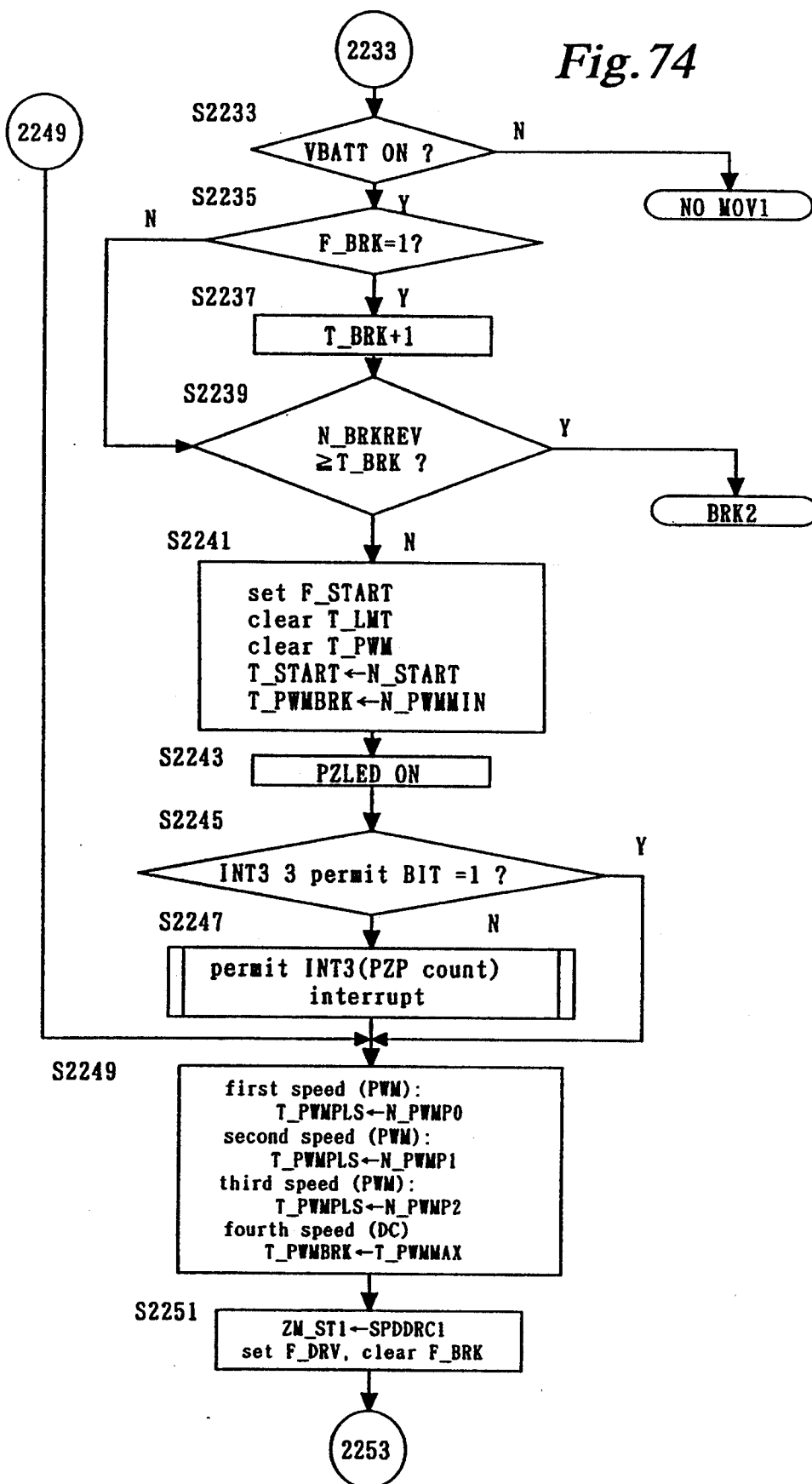

Fig. 75

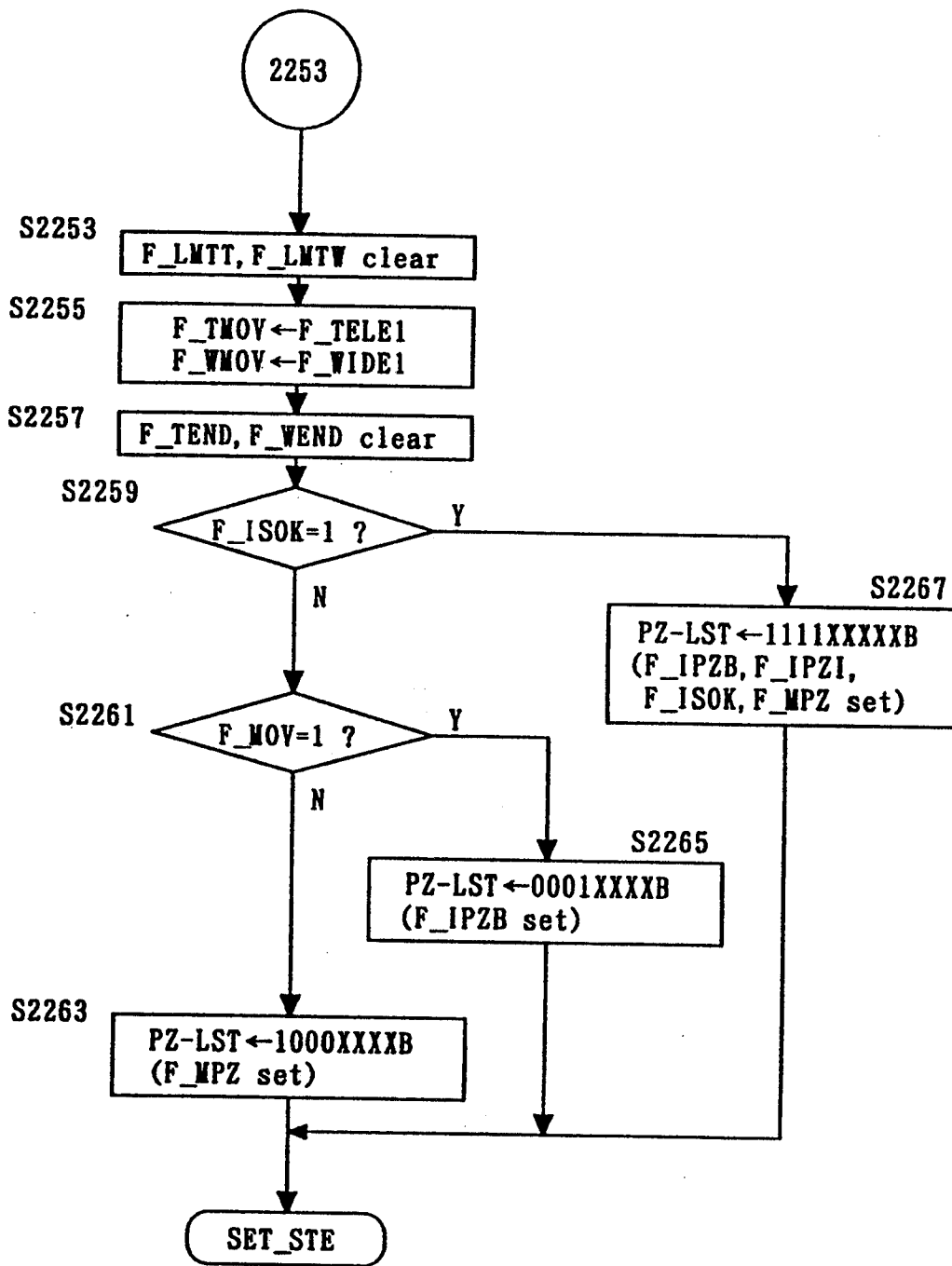

Fig. 76

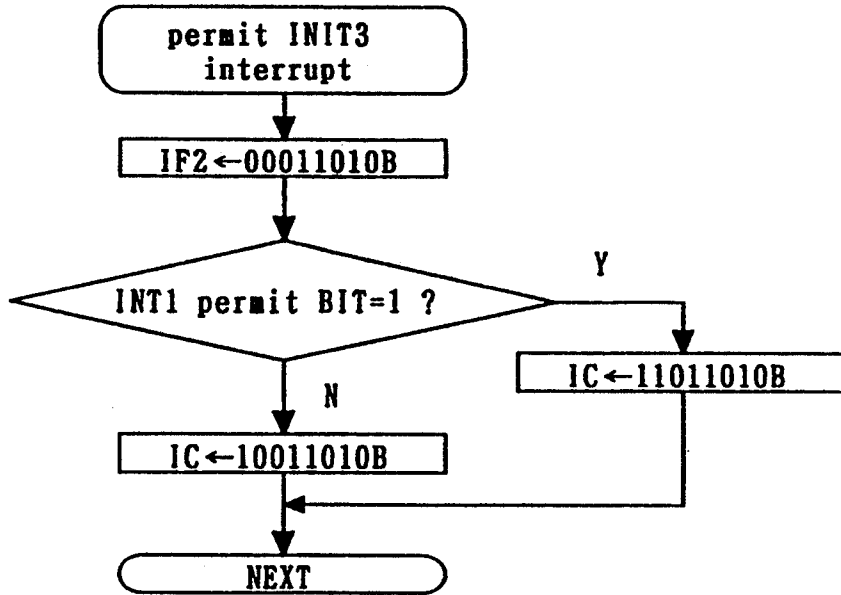

Fig. 77

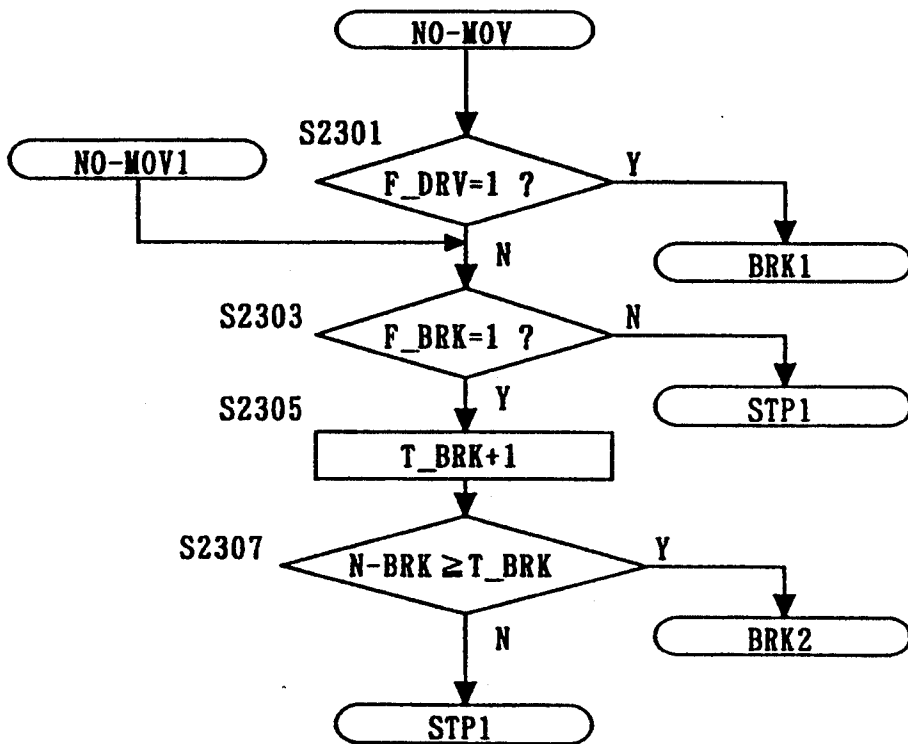

Fig. 78

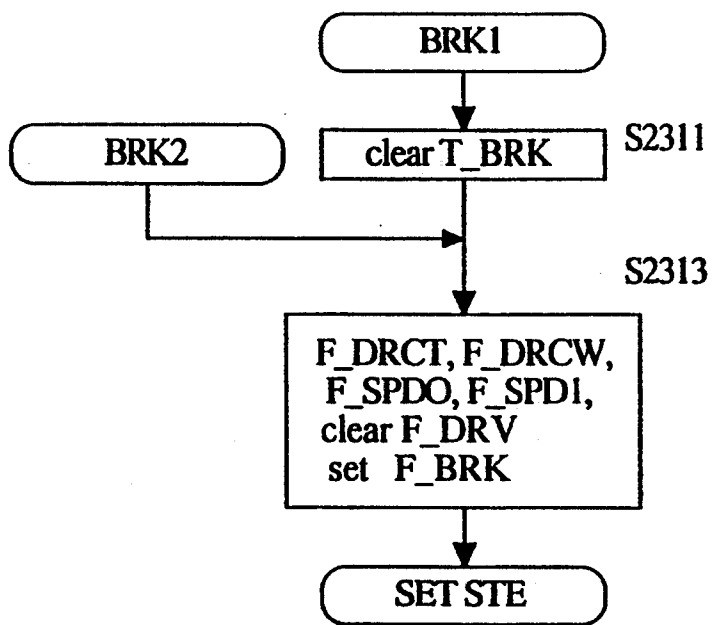

Fig. 79

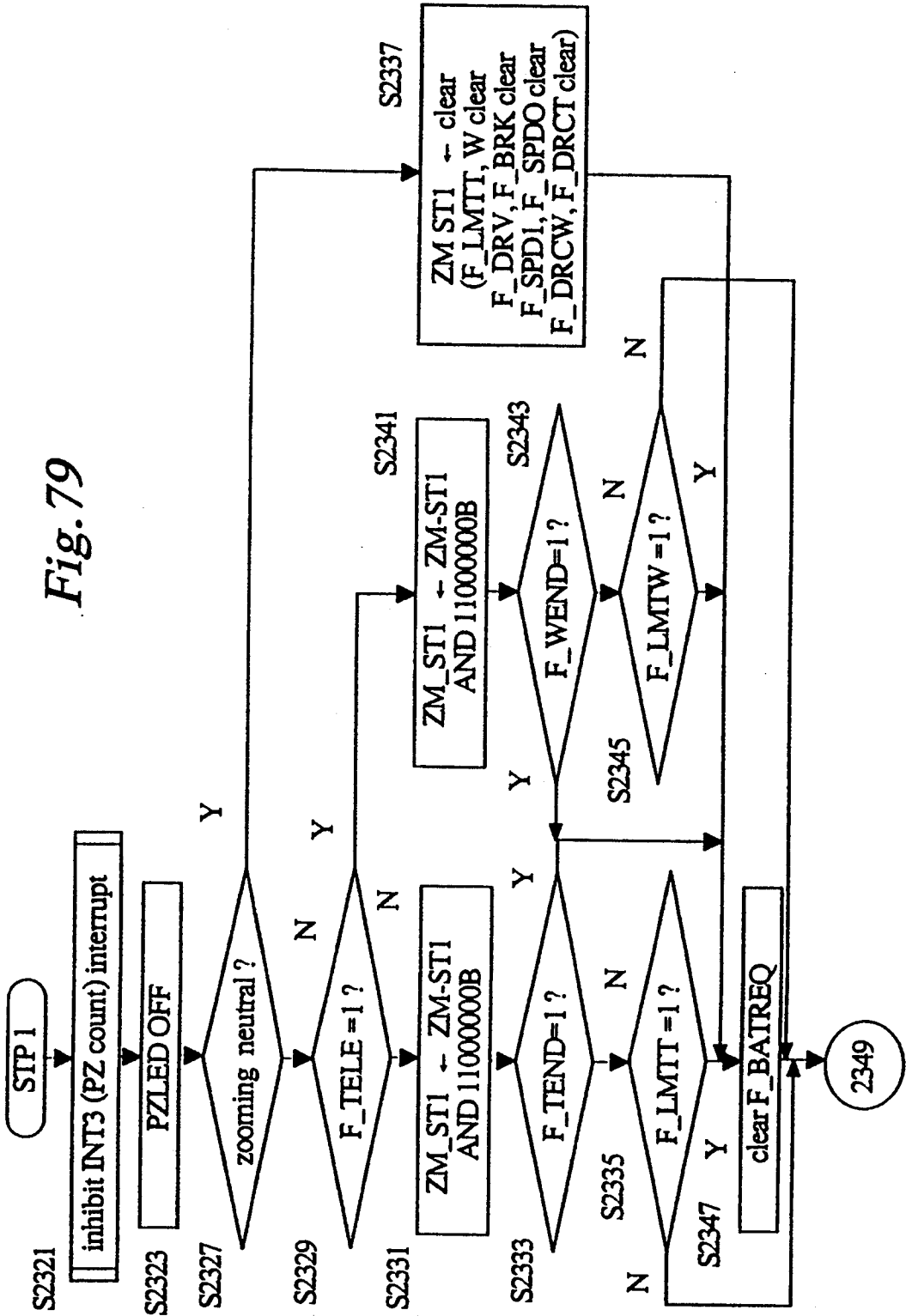

Fig. 80

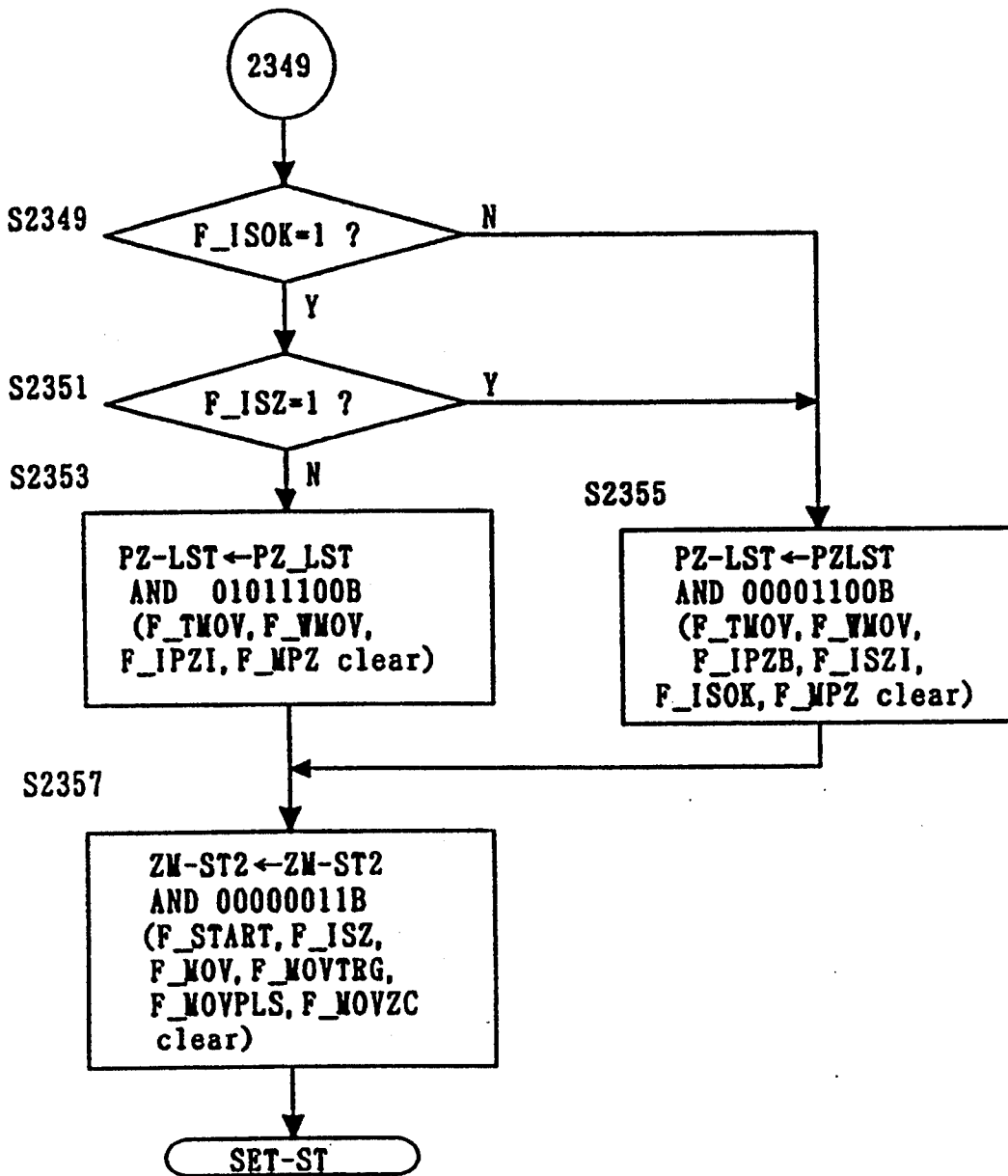

Fig. 81

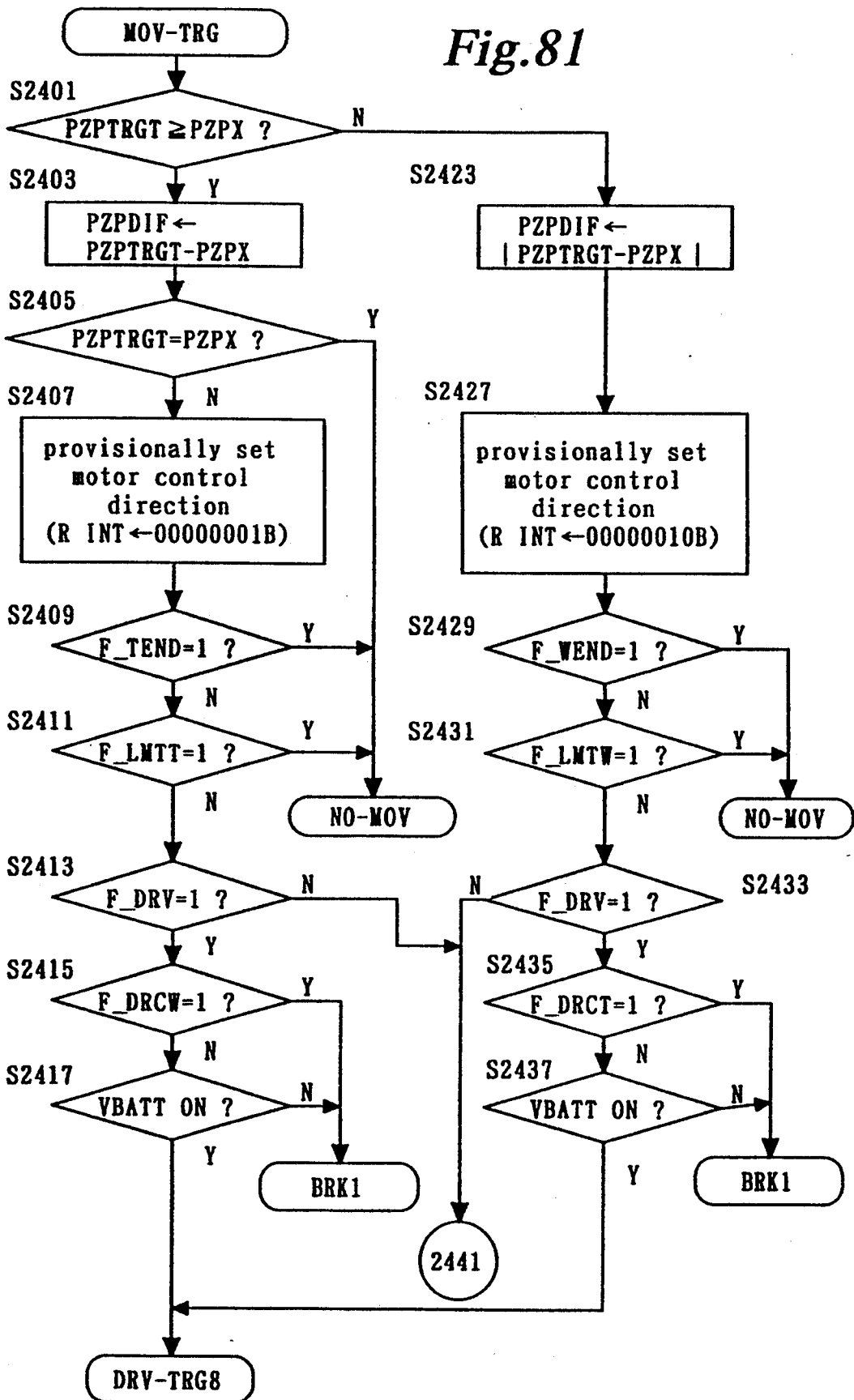

Fig.82

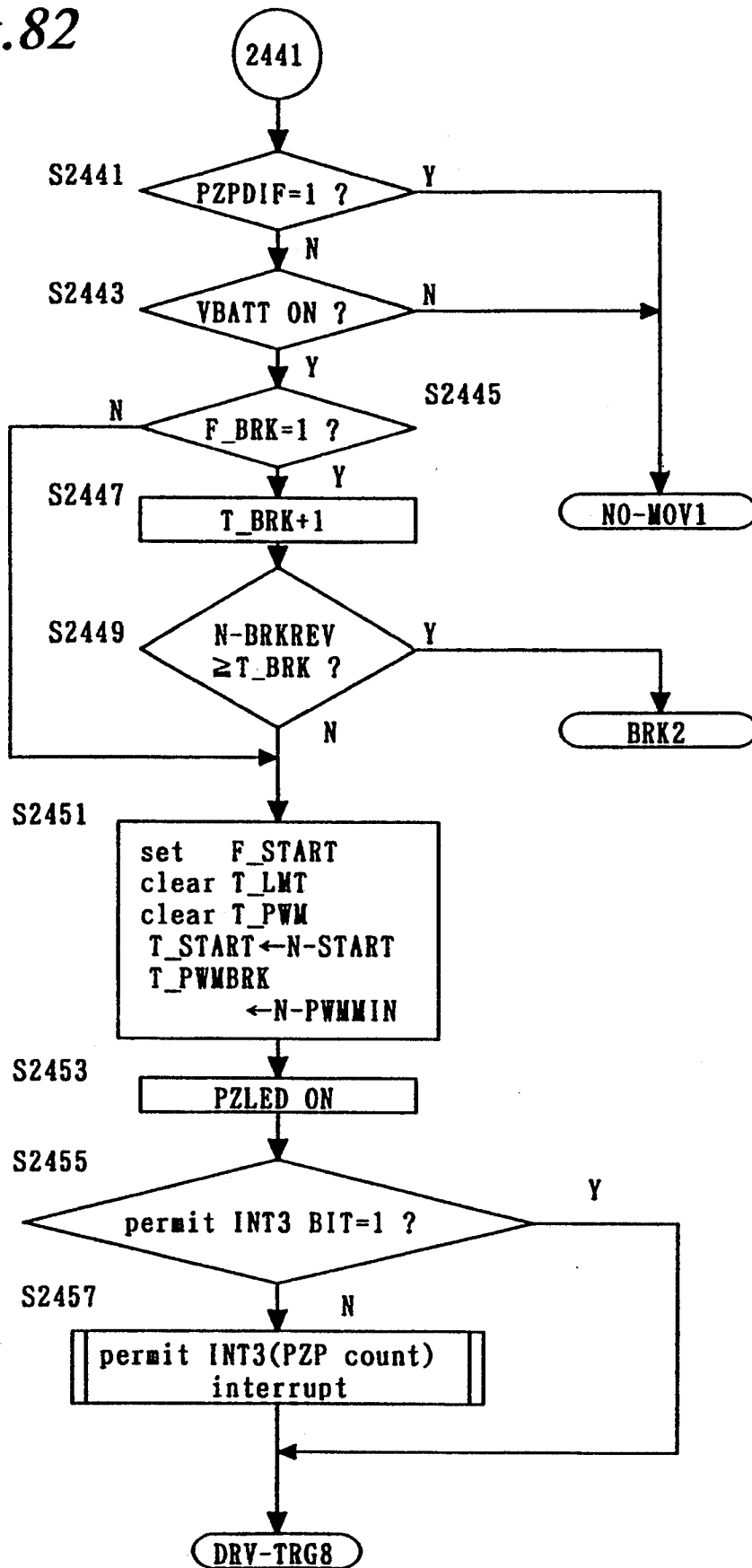

Fig. 83

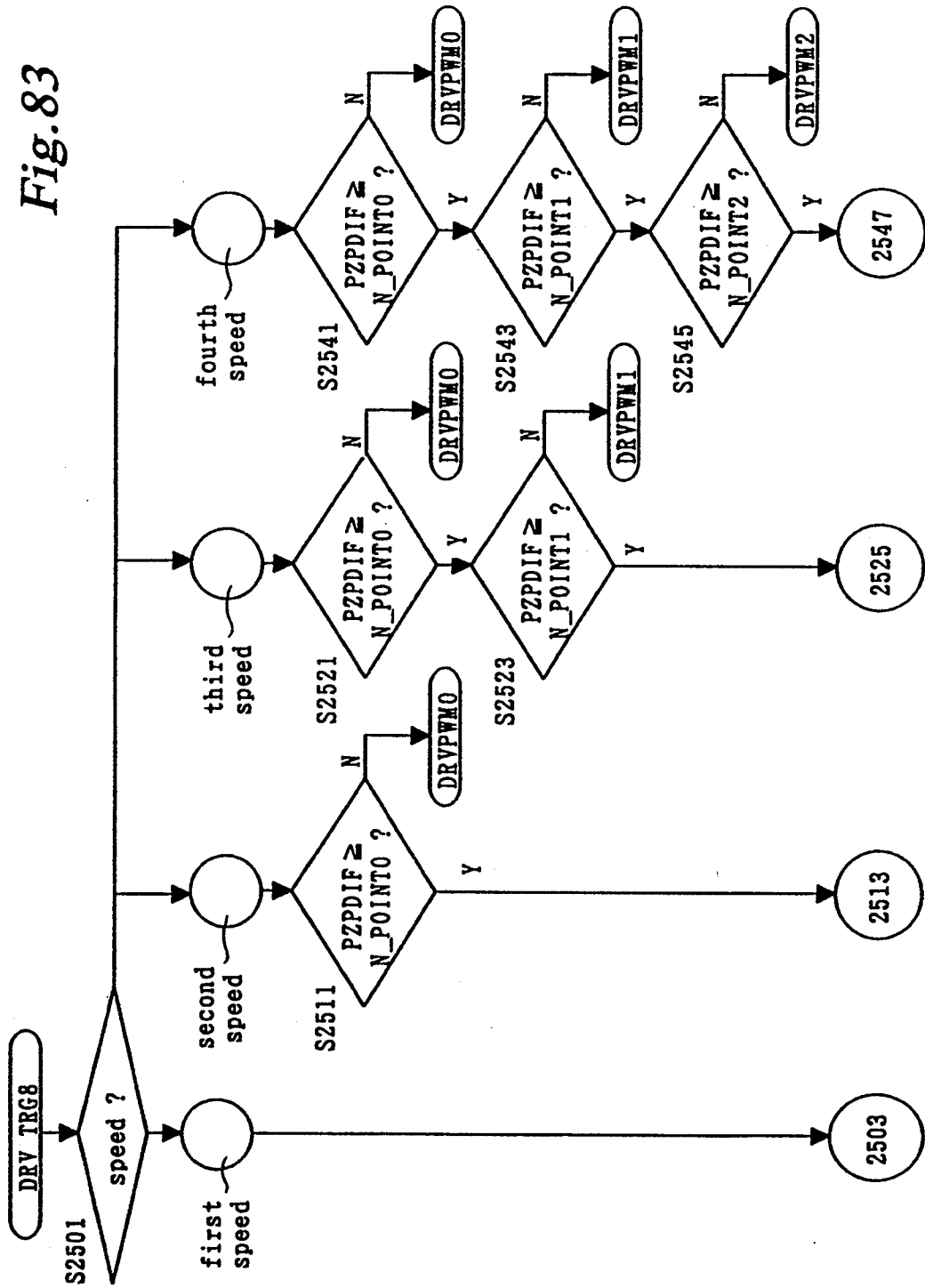

Fig. 84

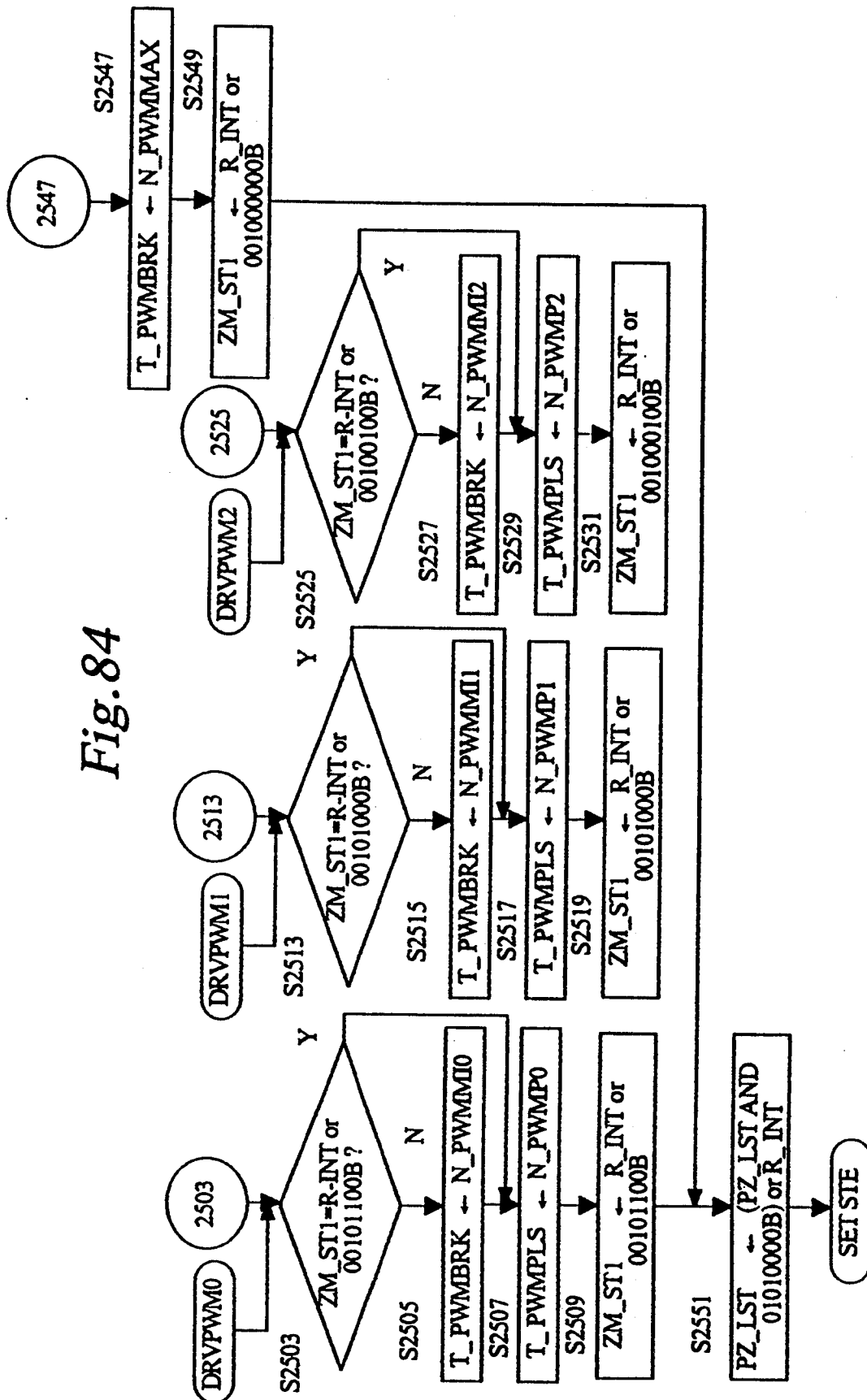

Fig. 85

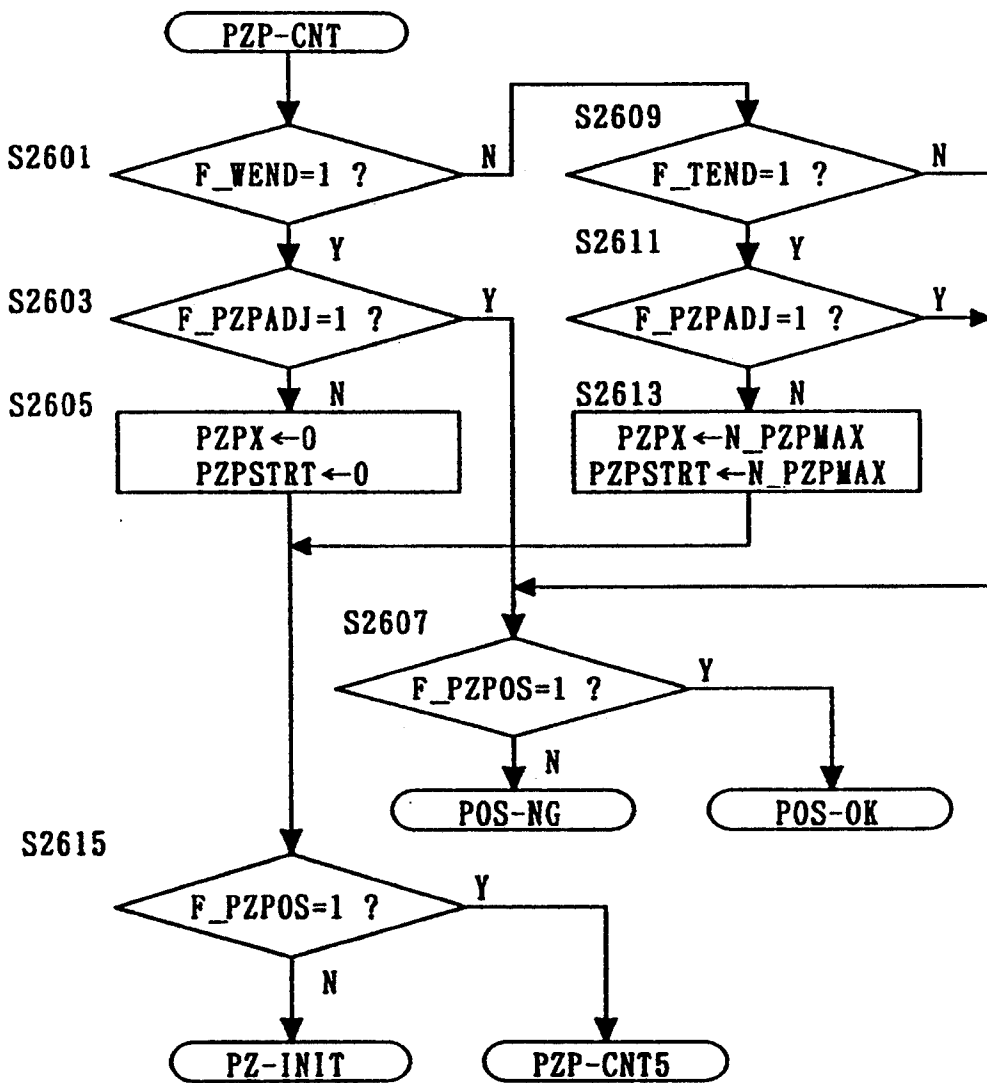

Fig. 86

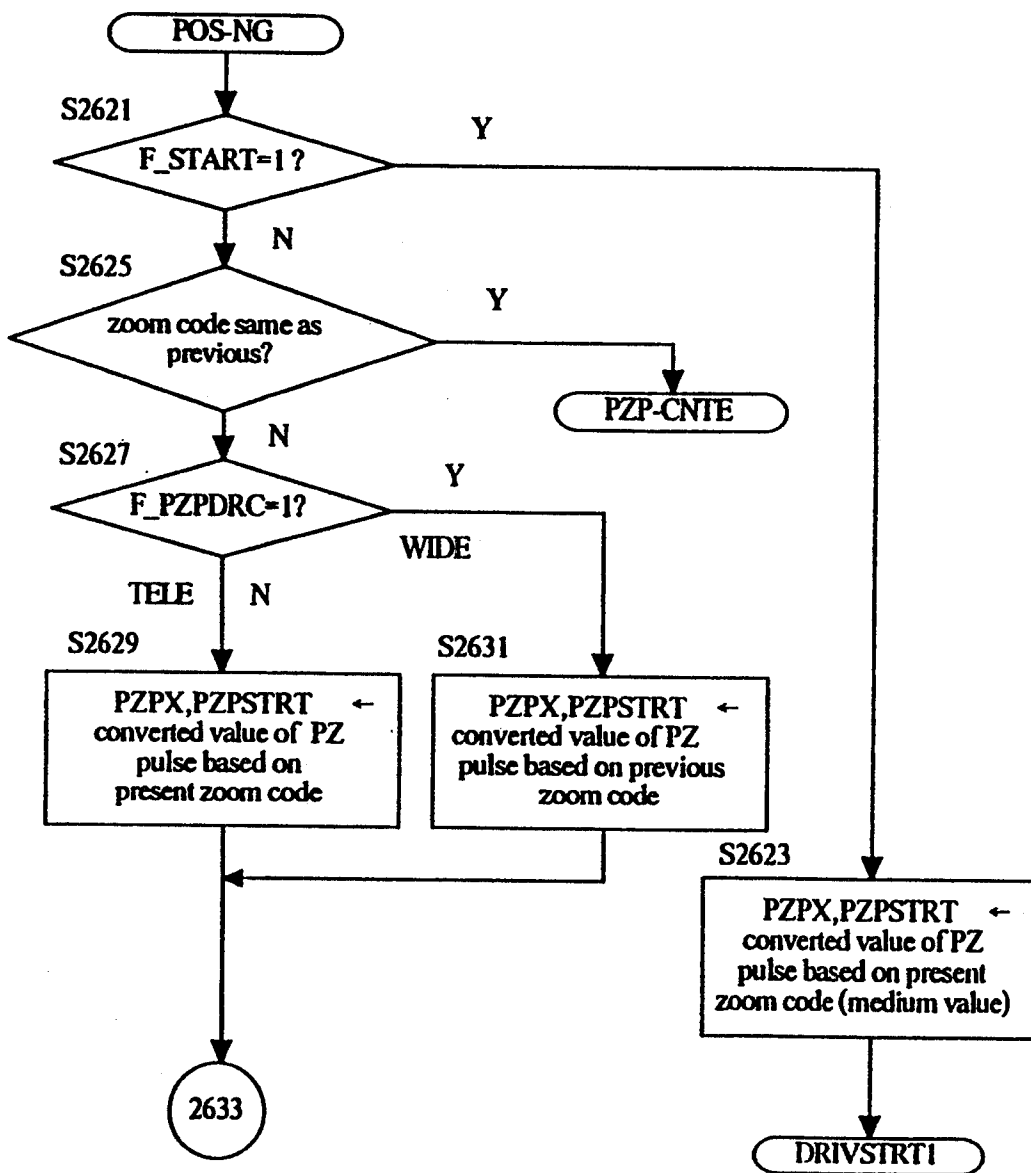

Fig. 87

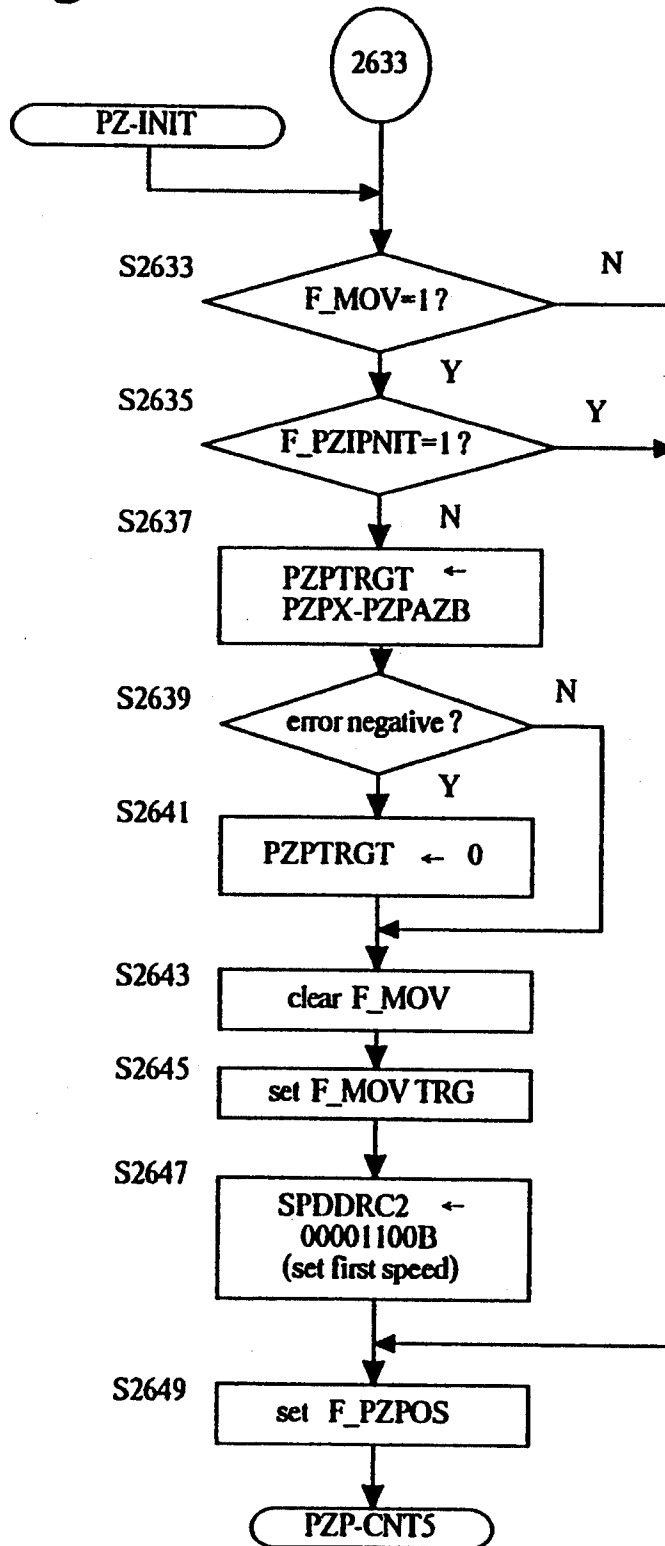

Fig. 88

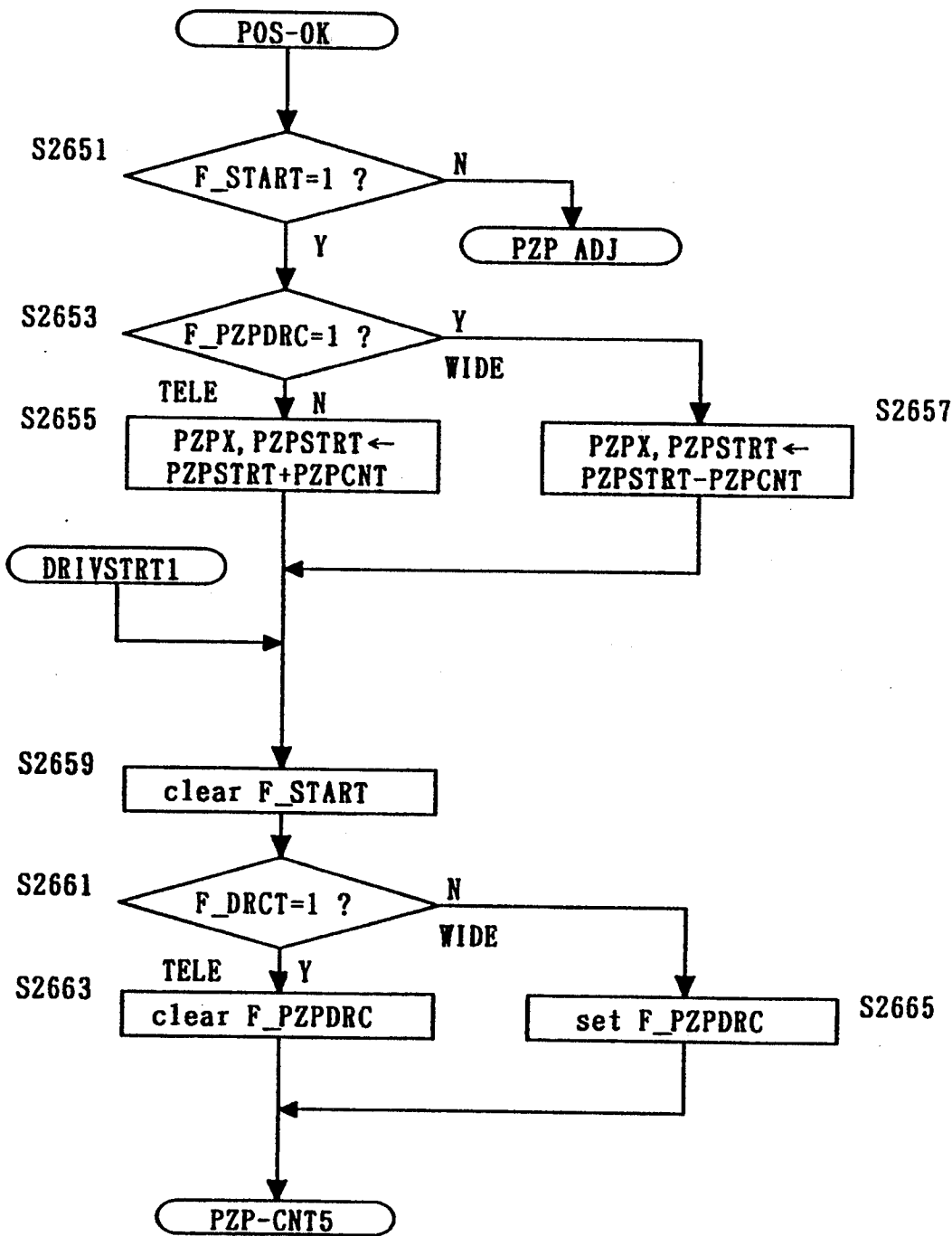

Fig. 89

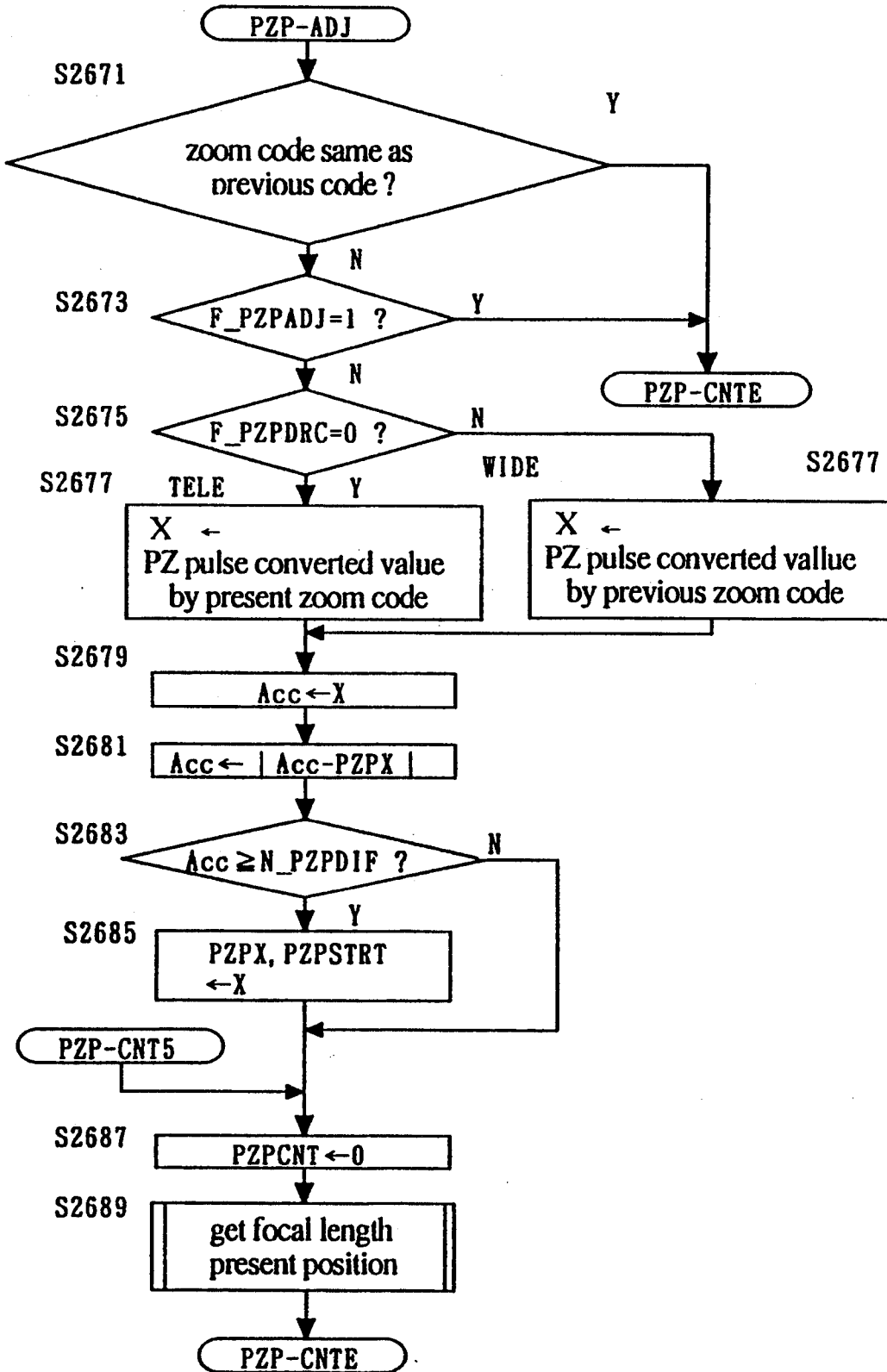

Fig. 89

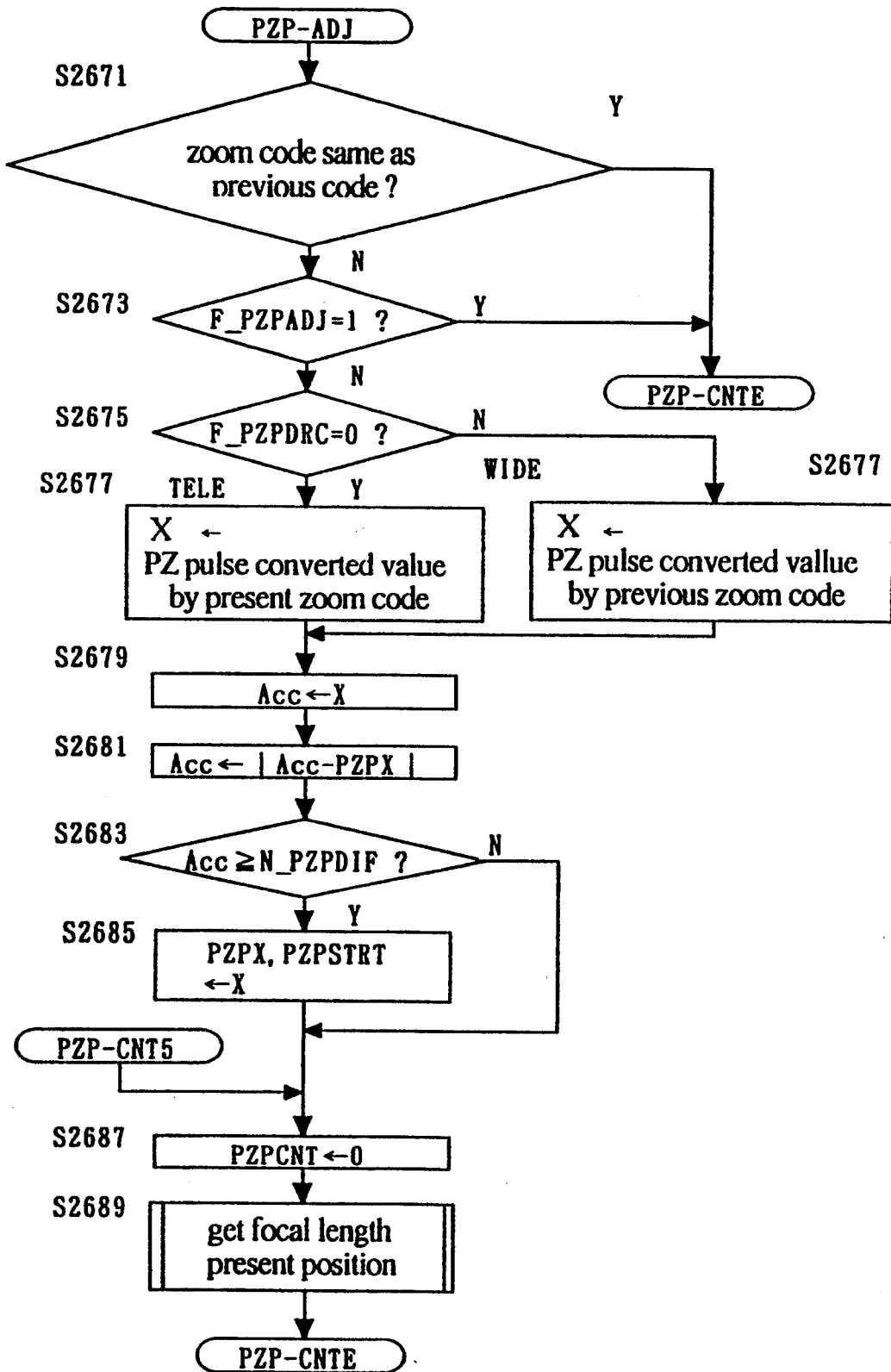

Fig.91

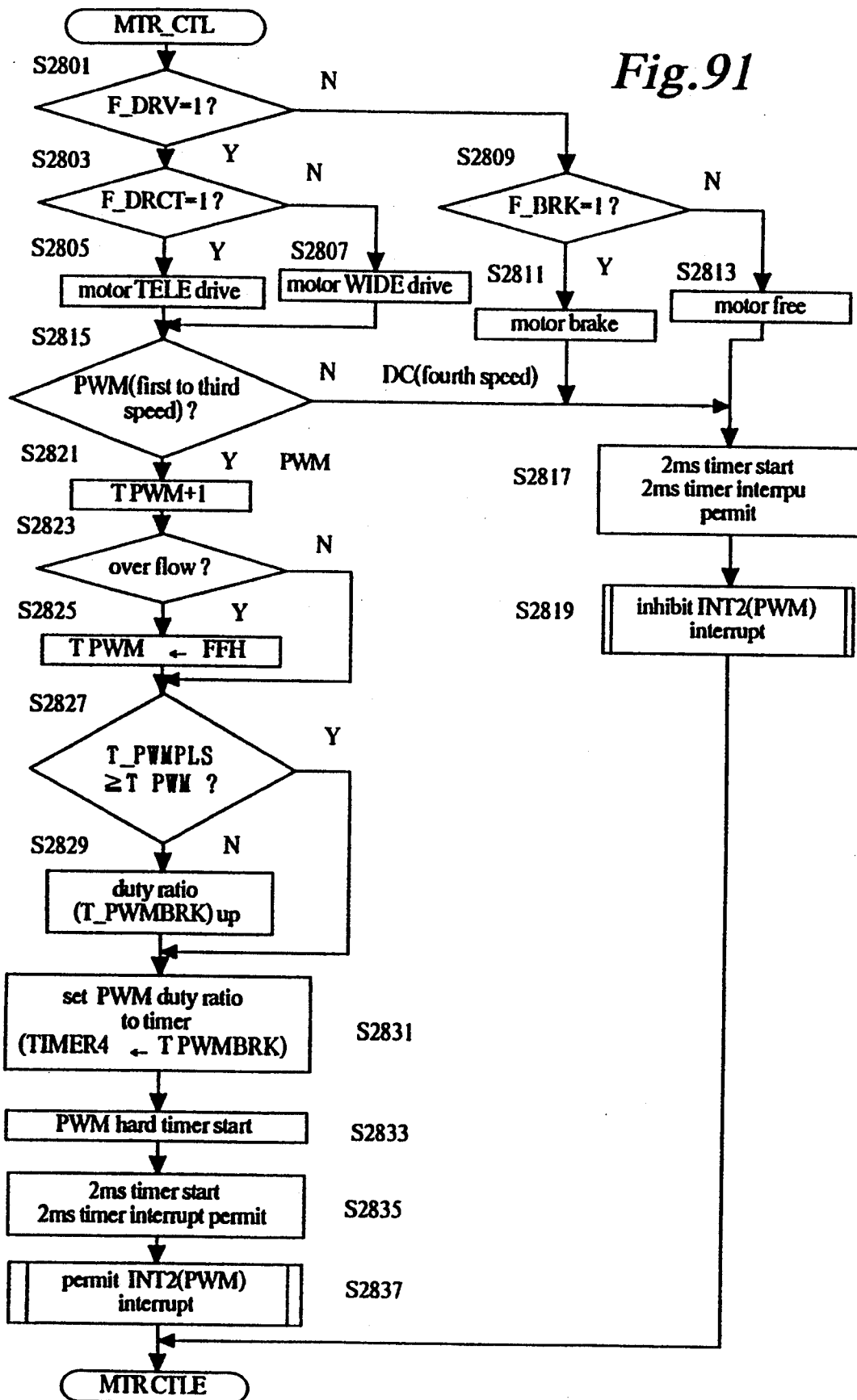

Fig.92

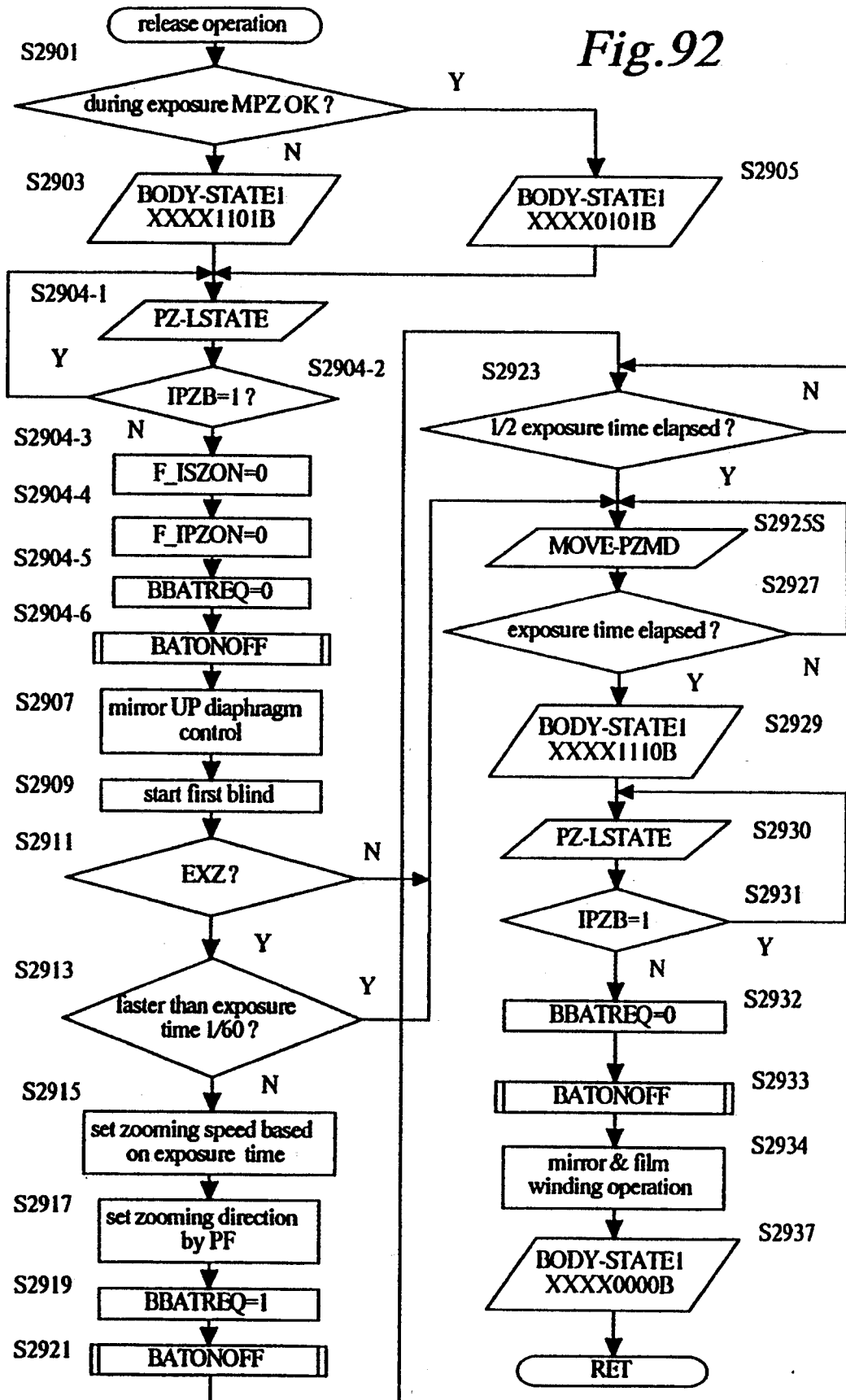

Fig. 93

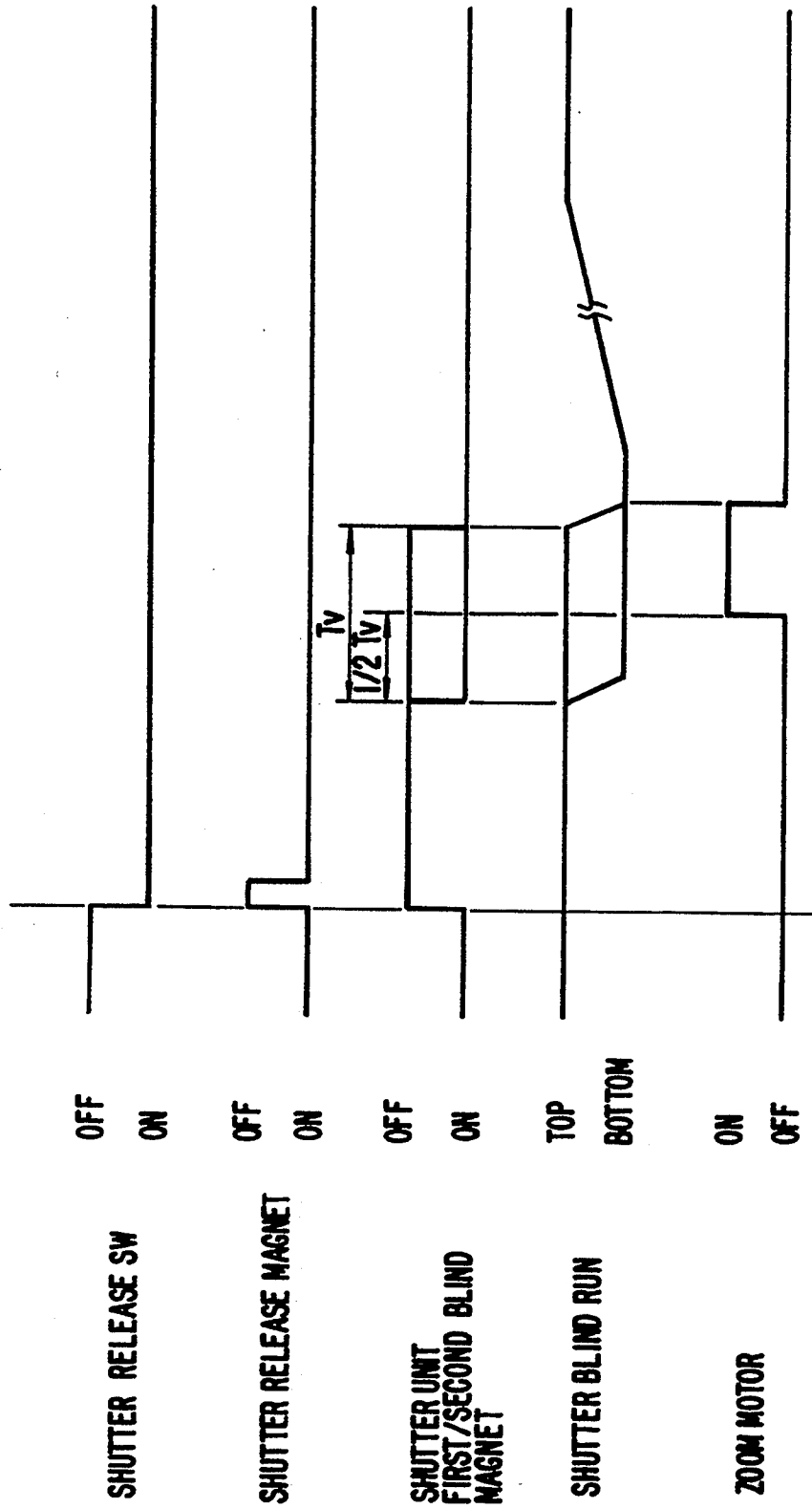

Fig.94

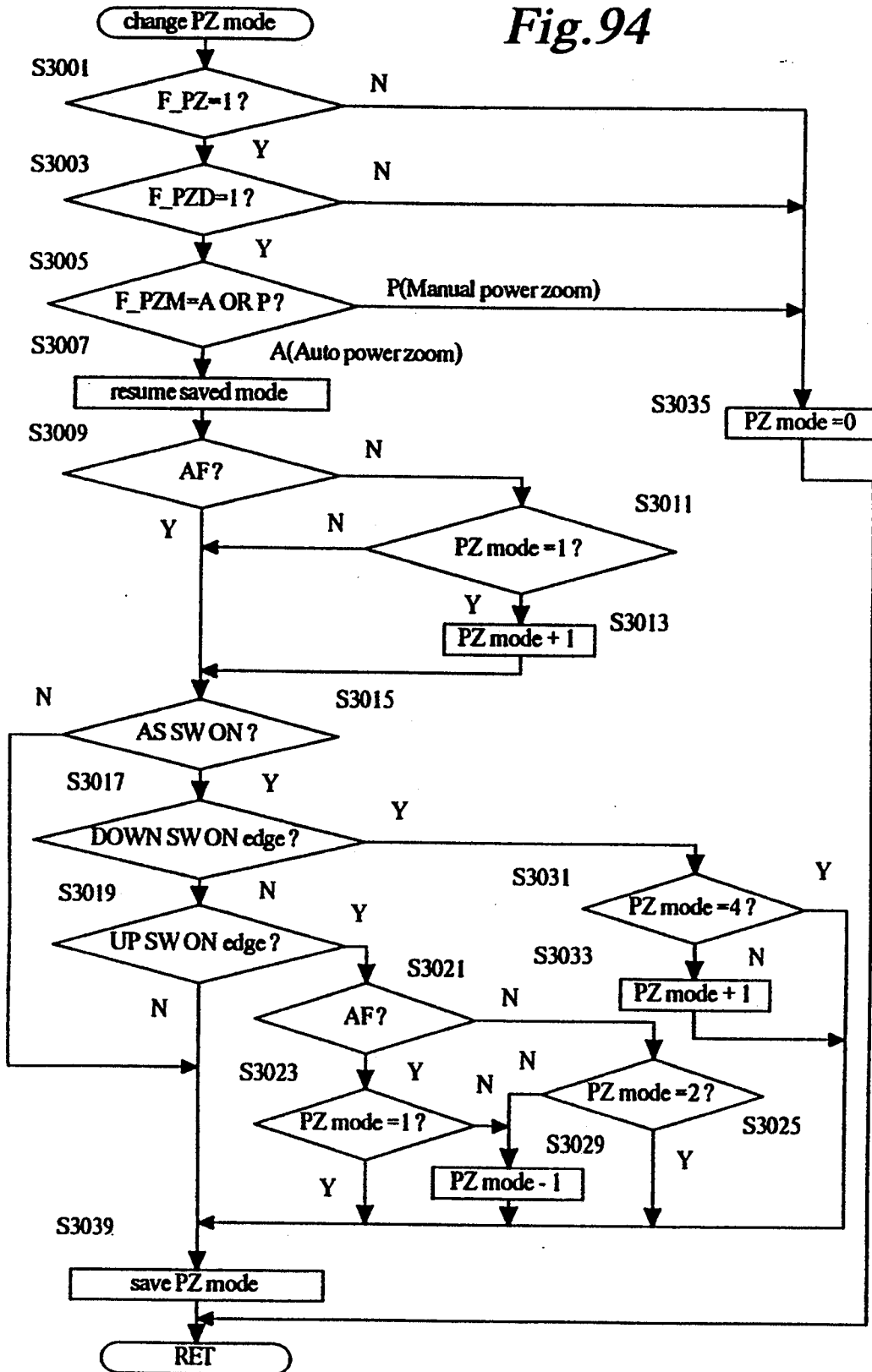

Fig. 95

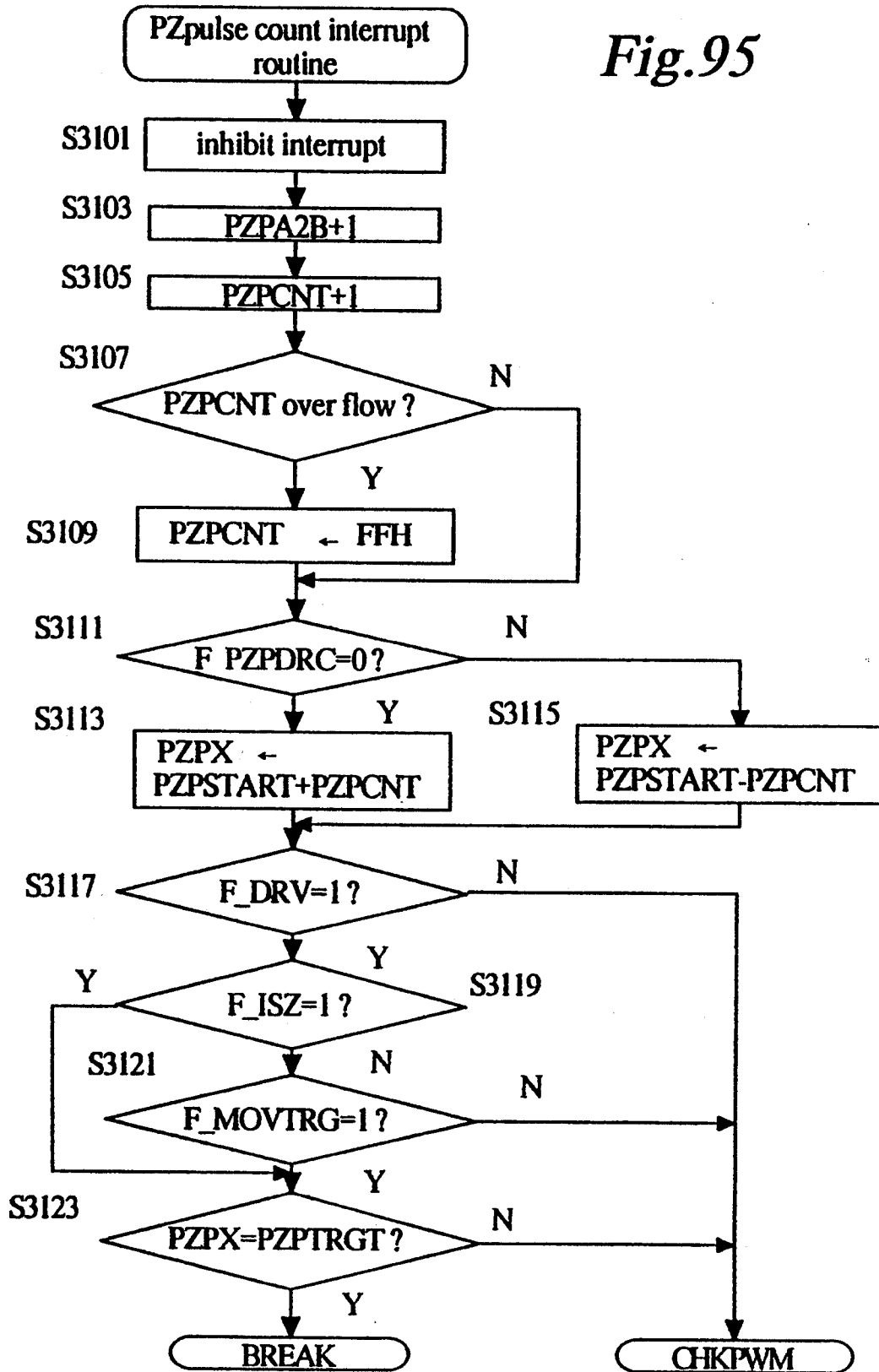
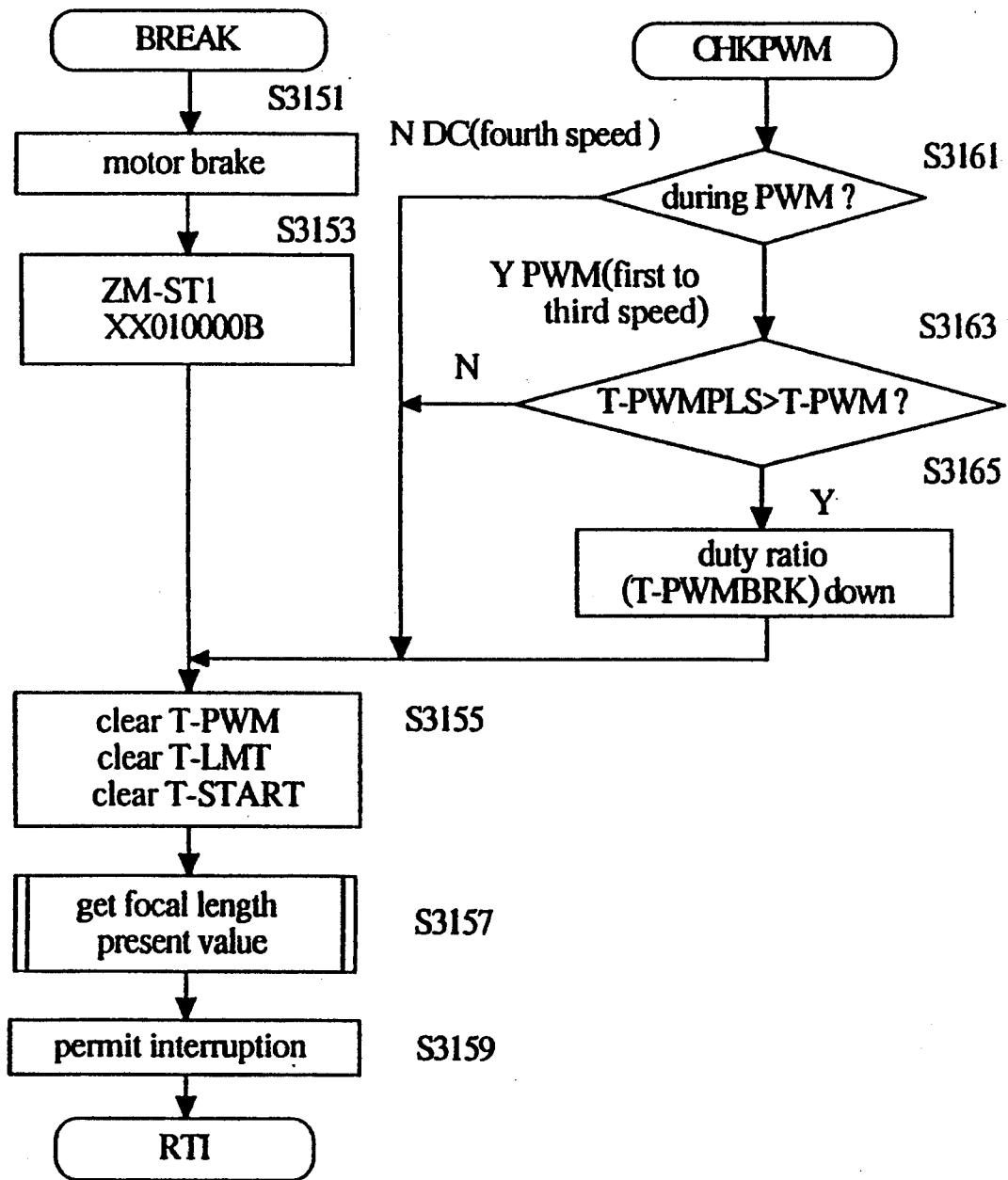

Fig.96



MOTOR DRIVEN LENS AND CAMERA SYSTEM

BACKGROUND OF THE INVENTION

1. Field of the Invention

The present invention relates to a motor driven lens having an automatic focusing device and a power zoom system, etc., and a camera system having such a motor driven lens.

This application is related to the commonly assigned applications U.S. Ser. Nos. 07/410,880, 07/652,038, 407,424, 07/414,477, 07/414,478, 07/670,733, 07/406,523, and 07/414,476, the disclosures of are which expressly incorporated by reference herein.

2. Description of Related Art

There are various known lens shutter type cameras having automatic focusing devices and power zoom lenses, in which zooming is effected by a motor. In a known lens shutter type of power zoom camera which has no interchangeable lens, the power zooming operation is controlled by a motor, a control means and a zooming switch, provided in a camera body. In a power zoom lens, the zoom motor must be stopped when the zooming lens group (i.e., variable lens and compensating lens) reaches an extreme position, beyond which the lens cannot be moved. At this point the power source is turned OFF to cut the supply of power to the zoom motor after a predetermined error checking time has elapsed from the point at which rotation of the zoom motor has been hindered. During the error checking time, the occurrence of an error or mal-operation is checked.

In the conventional camera, the error checking time is constant, independent of the number of revolutions of the motor. Accordingly, as motor overload increases, particularly when the motor is driven at high speed. Consequently, the motor and the driving system can be easily damaged. The same is true in a single lens reflex camera having an automatic focusing device in which a focusing lens group is driven by the motor. A lens group which is driven by a motor, such as a focusing lens group or a zooming lens group, will hereinafter be referred to as a motor driven lens.

Furthermore, it is necessary to detect the position of a focusing lens group and the position of a zooming lens group in order to obtain object distance data and focal length data, which are used to determine photographic requirements for taking a picture at optimum exposure.

In a known power zoom lens camera having an automatic focusing device, a detecting means for detecting the positions of the lens groups is, for example, formed by a code plate which detects absolute positions of the lens groups. For instance, in a conventional power zoom lens, the focal length is detected by a code plate which is secured to a zoom ring which rotates about or moves along the optical axis in accordance with the zooming operation. The code plate extends in the direction of movement of the zoom ring. A code reading member is provided on an immovable portion of the power zoom lens and is opposed to the code plate, so that the codes of the code plate are read by the code reading member to detect the focal length. The position of the focusing lens group can be similarly detected.

However, the detecting means made of the code plate can detect only the positions of the lens groups corresponding to switching points of the codes, but not the positions corresponding to the intermediate points between the switching points of the codes. Namely, only

a rough detection (measurement) can be effected (i.e., a precise detection (measurement) cannot be effected).

It is also known to count the number of pulses (i.e., add or subtract a number in accordance with the direction of movement of the lens groups) outputted from a pulse generator in association with the rotation of a motor for driving the lens group, in order to more precisely detect the position of the lens group. In this detecting means, it is inevitable that an error in the number of pulses counted by the counter will occur. To avoid such an error, in the conventional camera, the pulse number is corrected when the lens groups reach an infinite extremity, a macro extremity, a wide angle extremity, and a telephoto extremity, etc.

However, if the lens drive is forced to a stop for some reason, for example, when the focusing ring is immovably held by an operator, the motor is stopped. As a result, the control means may determine that the lens group has arrived at an extremity of movement, so that the pulse number counted by the counter is corrected or the counter is reset. Furthermore, even if the lens is to be moved (i.e., power is being supplied to the lens), there is a possibility that the lens movement may be impeded by an external force, preventing movement of the lens group beyond the stopped position to the associated extremity.

SUMMARY OF THE INVENTION

A primary object of the present invention is to provide a motor driven lens having an automatic focusing device and a power zooming function, wherein neither an overload of a lens driving motor and a driving mechanism, nor an operational failure occurs, even when an external force is exerted on the lens.

Another object of the present invention is to provide a camera system having such a motor driven lens.

To achieve the object mentioned above, according to the present invention, there is provided a motor driven lens includes a movable lens group and a lens moving mechanism which holds and moves the movable lens group in an optical axis direction within a predetermined movable limit, comprising a motor for driving the lens moving mechanism to move the movable lens group, a counter for counting the time in which a movement of the movable lens group is impeded during the operation of the motor, and a control means for controlling the operational speed of the motor and stopping the operation of the motor for a predetermined time in which the movement of the movable lens group is impeded, depending on the operational speed of the motor.

Preferably, the predetermined period of time of the motor driven lens decreases as the operational speed of the motor increases.

According to another aspect of the invention, there is provided a camera system comprising a camera body and a power zoom lens which can be detachably mounted to the camera body and which includes a zooming lens group and a lens moving mechanism which holds and moves the zooming lens group in an optical axis direction, comprising, a motor for driving the lens moving mechanism to move the zooming lens group, a counter for counting the time in which movement of the zooming lens group is impeded during the operation of the motor, and a control means for controlling the operational speed of the motor and stopping the operation of the motor for a predetermined period of

time in which movement of the zooming lens group is impeded, depending on the operational speed of the motor.

The present disclosure relates to subject matter contained in Japanese patent application Nos. HEI 3-218146 (filed on May 21, 1991) and HEI 3-342123 (filed on Nov. 29, 1991) which are expressly incorporated herein by reference in its entirety.

BRIEF DESCRIPTION OF THE DRAWINGS

FIG. 1 is a block diagram showing an outline of one embodiment of a body of a single lens reflex camera to which the invention is applied;

FIG. 2 is a block diagram showing an outline of one embodiment of a powered zoom lens for a single lens reflex camera to which the invention is applied;

FIG. 3 is a block diagram illustrating one embodiment of a circuit construction for the powered zoom lens;

FIG. 4 is a developed plan view of a zoom code plate of the powered zoom lens;

FIG. 5 is a developed plan view of a focal length code plate of the powered zoom lens;

FIGS. 6 and 7 are a main flow chart of a lens CPU;

FIG. 8 is a flow chart regarding communication interruption of the lens CPU of FIGS. 6 and 7;

FIG. 9 is a flow chart regarding a 2 ms timer interruption;

FIG. 10 is a flow chart regarding a powered zoom/manual zoom operation;

FIG. 11 is a flow chart regarding a PWM 2 ms timer interruption;

FIG. 12 is a flow chart regarding a PZ pulse count interruption treatment;

FIG. 13 is a flow chart regarding a PWM interruption;

FIG. 14 is a time chart regarding a PWM control;

FIGS. 15 and 16 are flow charts regarding a zoom control under constant image magnification;

FIGS. 17 and 18 are flow charts of a predictor operation regarding an amount of defocus;

FIG. 19 is a flow chart regarding a standby operation;

FIG. 20 is a flow chart regarding an initializing operation for an AF pulse;

FIG. 21 is a flow chart regarding an initialization operation for a powered zoom position;

FIG. 22 is a flow chart regarding an accommodation operation for the powered zoom lens;

FIG. 23 is a flow chart regarding a return operation for the powered zoom lens;

FIG. 24 is a flow chart regarding a stop operation for the powered zoom;

FIG. 25 is a flow chart that is effective upon receipt of data required for constant image magnification zooming;

FIG. 26 is a flow chart regarding a constant image magnification zooming operation;

FIG. 27 is a flow chart that is effective upon receipt of input information regarding constant image magnification zooming;

FIG. 28 is a flow chart that is effective upon receipt of an input regarding a condition of a camera body;

FIG. 29 is a flow chart that is effective upon receipt of input regarding body sequence information;

FIG. 30 is a flow chart that is effective upon receipt of an input regarding an AF pulse from the camera body side;

FIG. 31 is a flow chart that is effective upon receipt of an input regarding a PZ pulse from the camera body;

FIG. 32 is a flow chart that is effective upon receipt of a command which memorizes AF pulse data counted in the lens;

FIG. 33 is a flow chart regarding an operation for storing a defocus amount, determined by an AF on the body side, in a lens memory;

FIG. 34 is a flow chart regarding a storing operation for designated PZ pulse data and focal length data.

FIG. 35 is a flow chart regarding an operation for storing a defocus amount obtained in the AF on the body side in the lens memory;

FIG. 36 is a flow chart regarding an operation for storing constant image magnification zooming data received from the camera body;

FIG. 37 is a flow chart regarding a powered zooming in a designated direction or to a designated position;

FIG. 38 is a flow chart regarding the powered zooming operation based on data designated by the camera body;

FIGS. 39, 40, 41, 42 and 43 are a lens flow chart regarding an AF pulse count operation;

FIG. 44 is a flow chart regarding a transmission operation for the power zooming data on the photographing lens side;

FIG. 45 is a flow chart regarding a standby operation for the photographing lens;

FIG. 46 is a flow chart regarding a transmission operation for variable data of the photographing lens;

FIG. 47 is a flow chart regarding a transmission operation for fixed information of the photographing lens;

FIG. 48 is a flow chart regarding a transmission operation for an AF pulse count value on the lens side;

FIG. 49 is a flow chart regarding an output operation for real focal length data of the photographing lens;

FIG. 50 is a flow chart regarding a transmission operation for constant image magnification data on the photographing lens side;

FIG. 51 is a flow chart regarding the output of all lens data;

FIGS. 52, 53, 54, and 55 are a flow chart regarding a PZ actuation operation;

FIG. 56 is a flow chart regarding an initialization operation for the PZ;

FIGS. 57 and 58 are a flow chart regarding an initialization operation for the AF;

FIG. 59 is a flow chart regarding an operation for checking a supply of electricity;

FIGS. 60A, 60B, and 61 are a flow chart regarding a loop operation for the PZ;

FIG. 62 is a flow chart regarding an operation for checking for the completion of preset powered zooming;

FIGS. 63 and 64 are a flow chart showing a first embodiment of a constant image magnification zooming;

FIGS. 65 and 66 are a flow chart showing a second embodiment of constant image magnification zooming;

FIGS. 67 and 68 are a flow chart showing a third embodiment of constant image magnification zooming;

FIG. 69 is flow chart regarding an is operation for an AF pulse count;

FIG. 70 is a flow chart regarding an operation for adjusting an AF pulse count value;

FIG. 71 is a flow chart regarding an operation for a PZ terminal point;

FIG. 72 is a flow chart regarding an operation for controlling a rotational direction and rotational speed of a zoom motor;

FIGS. 73, 74, and 75 are a flow chart regarding a powered zooming operation by a zoom switch;

FIG. 76 is a flow chart regarding an interruption treatment for a PZ pulse count;

FIG. 77 is a flow chart regarding an operation for stopping a powered zooming;

FIG. 78 is a flow chart regarding an operation for braking the zoom motor;

FIGS. 79 and 80 are a flow chart regarding an operation for a setting state of the photographing lens;

FIGS. 81 and 82 are a flow chart regarding a powered zooming towards a designated focal length;

FIGS. 83 and 84 are a flow chart regarding an operation for adjusting a drive speed in accordance with a pulse number, which corresponds to a target position;

FIG. 85 is a flow chart regarding an operation for correcting the PZ pulse count when a terminal point is achieved;

FIG. 86 is a flow chart regarding an operation for correcting the PZ pulse counter when an actual or present position of the zooming lens is unknown.

FIG. 87 is a flow chart regarding an operation for correcting the PZ pulse counter when an actual or present position of the zooming lens is unknown;

FIG. 88 is a flow chart regarding an operation of the PZ pulse count when an actual or present position of the zooming lens is known;

FIG. 89 is a flow chart regarding an operation for correcting a PZ pulse counter;

FIG. 90 is a flow chart regarding an operation for presetting a focal length;

FIG. 91 is a flow chart regarding a drive control for the zoom motor;

FIG. 92 is a flow chart regarding a release operation on the camera body side;

FIG. 93 is a timing chart regarding an inter-exposure zooming;

FIG. 94 is a flow chart regarding an operation for changing modes of a powered zooming;

FIG. 95 is a flow chart regarding an interruption operation for the PZ pulse count;

FIG. 96 is a flow chart regarding an operation for controlling a PWM of a zoom motor;

DETAILED DESCRIPTION OF PREFERRED EMBODIMENTS

The invention will be explained below with reference to several embodiments illustrated in the drawings. In the drawings, FIG. 1 is a block diagram illustrating a main construction of the body portion of an autofocus (AF) single lens reflex camera to which the invention is applied. FIG. 2 is a block diagram illustrating a main construction of a powered zoom lens to which the invention is applied. FIG. 3 is a block diagram of the powered zoom lens circuitry to which the invention is applied.

The AF single lens reflex camera includes a camera body 11, and a photographing lens (powered zoom lens) 51 that is releasably attached to the camera body 11. Most of the luminous flux of an object to be taken (object flux) incident on the camera body 11 from a zooming optical system 53 of the photographing lens 51 are reflected by a main mirror 13 onto a pentaprism 15 constituting a finder optical system. A portion of the reflected light beam is also directed to a light receiving

element (not shown) of a photometric IC. A portion of the object flux, having been directed to the camera body 11 and made incident upon half mirrors 13 and 14, passes through the half mirrors and is reflected downwardly by a sub-mirror 19 to be directed onto a macrometric CCD sensor unit 21.

A photometric IC 17 includes a light receiving element for receiving the object flux. An electric signal generated by the light receiving element in accordance with the amount of light inputted into the light receiving element is subject to logarithmic-compression and A/D conversion and is then outputted, as a digital photometric signal, to a main (body) CPU 35. The main CPU 35 performs a predetermined operation on the basis of information, including the photometric signal and film speed, so as to calculate an appropriate shutter speed and diaphragm value for exposure. An exposure mechanism (shutter mechanism) 25 and a diaphragm mechanism 27 are driven on the basis of the shutter speed and diaphragm value.

Macrometric CCD sensor unit 21 is a macrometric sensor of a conventional phase difference type (not shown). The unit 21 includes a split optical system for splitting an object flux in half, and a CCD line sensor for receiving the split object fluxes so as to integrate them (i.e., storing photoelectric transfer and charges thereof). The macrometric CCD sensor unit 21 outputs data integrated by the CCD line sensor to the main CPU 35. The macrometric CCD sensor unit 21 is driven by a control circuit for peripheral parts 23. The macrometric CCD sensor unit 21 includes a monitor element. The peripheral parts control circuit 23 detects a luminance of the object (object luminance) through the monitor element, so as to change the integration time, based on the detected results.

Peripheral parts control circuit 23 performs a predetermined exposure operation on the basis of the digital photometric signal and film speed information, so as to calculate an appropriate shutter speed and diaphragm value for exposure. The exposure mechanism (shutter mechanism) 25 and diaphragm mechanism 27 are driven on the basis of the shutter speed and diaphragm value so as to perform an exposure. The peripheral parts control circuit 23, upon release, drives a mirror motor 31 by means of a motor drive circuit (motor drive IC) 29 so as to perform an up/down operation of the main mirror 13, and then drives a winding motor 33 so as to wind a film after completion of exposure.

Main CPU 35 communicates with lens CPU 61 so as to transmit data, command, etc. through the connection with the peripheral parts control circuit 23, a group of electric contacts BC mounted on the mount surface of the camera body, and a group of electric contacts LC mounted on a mount surface of powered zoom lens 51.

Main CPU 35 calculates a defocus amount by performing a predetermined operation (predictor operation) on the basis of the integrated data outputted from the macrometric CCD sensor unit 21, and calculates a rotational direction and rotational speed (i.e., pulse number of an encoder 41) of an AF motor 39. The main CPU 35 drives the AF motor 39 by means of the AF motor drive circuit 37 on the basis of the above rotational direction and pulse number.

Main CPU 35 counts a pulse that is outputted from the encoder 41 in accordance with a rotation of the AF motor 39. When the count amount reaches the above pulse number, the main CPU 35 stops the AF motor 39. The main CPU 35 quickly accelerates the AF motor 39

upon initial actuation thereof. Thereafter, the main CPU 35 activates a DC drive mode to decelerate the motor 39, so as to stop the motor 39 when it arrives at a target position. The main CPU 35 is capable of controlling the AF motor 39 at a constant speed in accordance with the time between pulses outputted from the encoder 41. Rotational movement of the AF motor 39 is transmitted to an AF drive mechanism 55 of the photographing lens 51 through a connection between an AF joint 47 mounted on the camera body 11 and an AF joint 57 mounted on the photographing lens 51. A group of focusing lenses 53F is driven by the AF drive mechanism 55.

Main CPU 35 has incorporated therein a ROM 35a for storing a program therein and a RAM 35b for storing predetermined data therein. An E²PROM 43 is connected to the main CPU 35 as an external memory means. The E²PROM 43 stores various functions and constants necessary for the operation or calculation of AF (autofocus) and PZ (power zoom), in addition to various constants inherent to the camera body 11.

Also connected to the main CPU 35 are photometric switch SWS, which is turned ON upon a half-depression of a release button (not shown), and a release switch SWR, which is turned ON upon a full-depression of the release button, an autofocus switch SWAF, a main switch SWM, which turns the electric supply to the main CPU 35 and Peripheral equipment ON/OFF, and an up-down switch SWUP/DOWN.

The set modes, such as AF mode, exposure mode and photographing mode, and exposure data, such as shutter speed and diaphragm value, are displayed on a display device 45 by means of the main CPU 35. Usually, the display device 45 is provided at two points, i.e., at points on the outer surface of the camera body 11 and in the field of view of a finder.

A pair of electric pins BPC for supplying electricity, obtained from a battery 20, to the photographing lens is provided adjacent to the mount of the camera body 11. A pair of electric pins LPC, which are electrically connected with the electric pins BPC upon mounting, is also provided on the powered zoom lens 51.

Powered zoom lens 51 includes, as a photographing optical system, a zooming optical system 53, which has a group of focusing lenses 53F and a group of zooming lenses 53Z.

The group of focusing lenses 53F is driven by an AF mechanism 55. The driving force of the AF motor 39 is transmitted to the AF mechanism 55 through the AF joints 57 and 47. An AF pulse outputted from an AF pulser in accordance with the rotation of the AF mechanism is counted and measured by a lens CPU 61. The lens CPU 61 includes an AF pulse hardware counter for counting the AF pulse.

The group of zooming lenses 53Z is driven by a PZ (power zooming) mechanism 67. A zoom motor 65 for driving the PZ mechanism 67 is controlled by the lens CPU 61 via a motor drive IC 63. The amount of displacement of the group of zooming lenses 53Z is counted and measured by the lens CPU 61, which counts PZ pulse outputted from a PZ pulser 69 in accordance with the rotational movement of zoom motor

Pulsers 59 and 69 include a rotatable disk which has a plurality of slits extending in a radial direction thereof and spaced in a circumferential direction in an equidistant manner, for example. The pulsers 59 and 69 further include LEDs and photodiodes (photo-interrupter), each disposed at opposite sides of each of the slits. The

rotatable disk of each of the pulsers 59 and 69 rotates sequentially with the rotation of the AF mechanism 55 and PZ mechanism 67. The LED of each of the pulsers 59 and 69 is controlled by the lens CPU 61 to be turned ON/OFF and the outputted to (pulse) of the photodiode is input in the lens CPU 61.

The absolute position of the group of zooming lenses 53Z (i.e., focal length) and the absolute position of the group of focusing lenses 53F (i.e., object distance to be focused upon) are detected by a zoom code plate 71 and distance code plate 81, respectively. FIGS. 4 and 5 illustrate developed views of the code plates 71 and 81, respectively. Brushes 73 and 85 slidably engage with an array of codes 71a-71f of the code plate 71 and an array of codes 81a-81e of the code plate 81, respectively.

Code 71a and code 81a of the code plates 71 and 81, respectively, are grounded. A plurality of codes 71b-71e and 81b-81e are connected to an input port of the lens CPU 61. The total range of displacement of the group of zooming lenses 53Z is divided by an the zoom code plate 71 into 26 segments. Each of the segments is distinguished by absolute positional (i.e., focal length) information with 5 bits. The total range of displacement of the group of focusing lenses 53F is divided by the distance code plate 81 into 8 segments. Each segment is distinguished by an absolute position (i.e., distance of object) information with 3 bits. The relative position in each divided segment is detected by counting the pulse number outputted from the pulser 69 and 59. Indicia 83 of the array of codes 81e of the distance code plate 81 is provided to detect a central position of each of the segments. A boundary position 72 of each segment of the code plate 71 and the indicia 83 of the code plate 81 is used as a critical position at which point a count value of each of the pulsers is corrected.

Powered zoom lens 51 includes, as actuation switches, a switch 75 for changing a zoom speed, and a switch 77 for changing a zoom mode. The zoom speed changing switch 75 includes a switch (the detail of which is not shown) which controls, in the powered zooming mode, a tele-direction zooming and a wide-direction zooming, and three zoom speed modes in each of the zooming directions. The zoom mode changing switch 77 includes a switch for changing between a powered zooming and a manual driven zooming (D/M), a PA switch for changing between a manual powered zooming mode and a plurality of powered zooming modes performed under a constant control, and a SL switch for storing an actual focal length or the like during a controlled, powered zooming mode (i.e., powered zooming mode under constant image magnification). Although not specifically shown in the drawings, the zoom speed changing switch 75 will be actuated sequentially with a zoom operating ring which is inserted into a lens barrel for rotation and displacement in the optical axis direction, and which is normally urged toward a neutral position with respect to the rotational direction. The zoom operating ring also includes a mechanism for mechanically changing between the powered zooming and the manual zooming.

The contacts of the zoom speed changing switch 75 and zoom mode changing switch 77 are connected to the lens CPU 61. The lens CPU performs a control operation with respect to the powered zooming in response to an actuation of the switches.

Lens CPU 61 is connected with the main CPU 35 through an interface 62, communication contacts LC and BC, and peripheral parts control circuit 23 of the

camera body, so as to perform a bi-directional communication with the main CPU 35 of predetermined data. The data to be transmitted from the lens CPU 61 to the main CPU 35 includes, for example open diaphragm value AVMIN, maximum diaphragm value AVMAX, minimum and maximum focal length, actual focal length, actual distance of an object, K-value information, as well as, AF pulse number, PZ pulse number etc. "K-value" is intended to be pulse number data of the encoder 41 (AF pulser 59) necessary to displace the image surface, imaged by the zooming optical system 53, by a unit length (for example, 1 mm).

FIG. 3 is a block diagram illustrating the circuit of the powered zoom lens 51 in more detail. A group of electric contacts LC includes 5 terminals, i.e., CONT terminal connected to the interface 62, RES terminal, $\overline{\text{SCK}}$ terminal, DATA terminal and GND terminal. Through the CONT terminal and GND terminal, a voltage necessary for the actuation of the lens CPU 61 is supplied from the camera body 11, and through the remaining terminals, i.e., RES terminal, $\overline{\text{SCK}}$ terminal and DATA terminal, communication is performed. In principle, the RES terminal is assigned to a reset signal, $\overline{\text{SCK}}$ terminal is assigned to a clock, and the DATA terminal is assigned to data communication, such as predetermined information and commands. It is noted that any elements which are denoted with this prefix correspond to an active-low or reversed signal. Electricity pin LPC includes a VBATT terminal and PGND terminal. Electric power necessary to drive the zoom motor 65 is supplied from battery 20 in the camera body 11 through the VBATT and PGND terminals. The supply of electricity is controlled by the CPU 35 by means of the peripheral parts control circuit 23. In the drawings, reference numeral 91 designates a clock generation circuit. The VBTT terminal is connected both with a motor drive IC 63 and port P12 of the lens CPU 61, which is for monitoring the battery voltage, through a register R4.

Main Operation of the Lens CPU

The main operation of the lens CPU 61 will be explained below with reference to FIGS. 6 and 7. Instruction commands are shown in Tables 1 and 2. Commands (data) utilized to transmit various camera body data from the camera body to the lens are shown in Table 3. Commands utilized to transmit various lens data from the lens to the camera body are shown in Table 4. A memory map of RAM 61b of the lens CPU 61 is shown in Tables 5 to 11.

In the main routine, the lens CPU 61 first sets a high-speed actuation mode (Step (hereinafter "S") 101). The lens CPU 61 performs an inhibition of interruption operation, sets a stack address, initializes port P, and then inputs the present absolute zoom code from the zoom code plate 71 (S103-S109). Then, data that is calculated based on the zoom code is stored in the RAM 61b, and a group of data (LC0-LC15 in Table 5) stored in the RAM 61b, by means of communication (former communication) in accordance with a clock signal of the camera body 11, is transmitted to the camera body (S111). After completion of communication, a 3-ms timer is started (S113).

When the former communication has been completed, a KAFEND signal ("L" level) will be outputted from the interface 62 before 3 ms has passed, in accordance with the 3 ms timer. However, if the former communication completion signal (KAFEND signal) is

not outputted before 3 ms has passed, in accordance with the 3 ms timer, a stop operation (stopping of clock 91) is performed to break the main routine (S115, S117, S119). When the KAFEND signal is outputted before 3 ms has passed, the operation has been performed in a normal manner. Accordingly, a command is received from the camera body 11 by means of communication. If the received command is not a new communication command, identifying the camera as one which is suitable for a new communication, a stop operation is performed to prevent a mis-communication with a camera body which is unsuitable for the new communication (S121, S123, S119). The "new communication" is defined in this specification as a state in which a bi-directional communication of commands and data is possible between the camera body and photographing lens in synchronization with the clock of the photographing lens.

When the new communication command is received, a command receipt completion signal is outputted to the camera body, so as to start a permission of a 2 ms timer interruption, permit interruption of new communication, and permit other possible interruptions (S123, S125, S127, S128, S129). Accordingly, an interruption operation of the 2 ms timer and interruption of new communication is made possible. The above operations are all initially performed when the main switch of the camera body 11 is turned ON and electricity is supplied from the camera body 11. While the main switch is ON, the following operations will be repeated.

A zoom code is inputted from the zoom code plate 71 (S131). If the zoom code is different from the previous one, distance code data is inputted and lens code data LC2, including the distance code data, is stored in RAM 61b (see FIG. 2). Then, an operation or calculation is performed on the basis of the data of zoom code, so as to store the calculated data in the lens RAM 61b as LC0-17 and LB4, LBB data (S133, S135, S137). If the zoom code is the same as the previous one, distance code data is inputted from the camera body 11 and lens code data (LC2), including the distance code data, is stored in the lens RAM 61b at a predetermined address (S133, S139, S141).

It is determined whether there was a stop demand during communication interruption from the camera body (i.e., whether flag F_STANDBY is set), or whether there was an electric demand during interruption of the 2 ms timer (i.e., whether flag F_LBATREQ is set). When there is no stop demand, or when there is electric demand, a constant image magnification operation (ISZ) is performed, followed by a NIOST operation (i.e., the process is returned to step S131 of the main routine so as to repeat the above operation). The above corresponds to steps S143, S145 and S147. It is to be noted that "electricity demand" is a demand which asks the camera body 11 (body CPU) to supply the powered zoom lens 51 with electricity from the battery 20 in order to drive the zoom motor 65 via electric source pins BPC and LPC.

When a stop demand exists and a battery or electricity demand does not exist, a stop operation is performed after making a preparation for stopping (i.e., preparation for inhibition of the 2 ms timer interruption and cancellation of stop). The above corresponds to steps S143, S145, S149 and S151. The lens CPU 61 stops the clock 91 to enter the low power consumption mode (standby). The stopped state (low power consumption mode) can only be cancelled by, for example, a commu-

nication interruption from the camera body, and the process returns to the normal operation (clock 91 operation). When returning to the normal operation, the process returns to step S153 after completion of the communication interruption routine. When the stop demand is cancelled or the electricity demand is generated in the communication interruption, the process returns to S131 after permitting a 2 ms timer interruption and starting the 2 ms timer. Otherwise, the process returns to step S149 to again enter the stop condition or the power save mode (S153, S155, S157).

INT1 OPERATION

A communication interruption operation, shown in FIG. 8, is performed by the lens CPU 61 and will be explained below. An INT1 operation is an operation to conduct communication interruption in which an operation is performed on the basis of the commands and data, etc. received during communication. This operation commences when the interruption signal outputted from interface 62 is inputted to port INT1 of the lens CPU 61.

When the process enters the communication interruption, the communication interruption is inhibited and a command is inputted from the camera body 11 after clearing the stop flag (F_STNDBY) and an NG flag (F_SCKNG, F_CMDNG) in steps S201, S203 and S205. The process checks the upper 4 bits of the command as inputted and proceeds to an appropriate subroutine, depending on the upper bits (S207 and S229). In each of the subroutines, an appropriate operation is performed depending on the lower bits. In the illustrated embodiment, subroutines making identification from the upper 4 bits include a BL command subroutine, instruction code subroutine, a 16-byte (first half 8-byte data/second half 8-byte) data subroutine, byte by byte data subroutine, and a test mode subroutine (S209, S213, S217, S221, S225 and S229).

If the above 4 bits are not those set above, the process sets command NG flag F_CMDNG and returns to the main routine after permitting communication interruption (S227, S231 and S233).

2 ms TIMER INTERRUPTION OPERATION

The operation of the lens CPU 61 when receiving an interruption of the 2 ms timer will be explained below with reference to a 2 ms timer interruption flow chart shown in FIG. 9. The 2 ms timer is a hard timer that is incorporated in the lens CPU 61 for outputting interruption signals every 2 ms. The 2 ms timer interruption is a periodic interval operation which conducts an interruption operation upon the passing of the 2 ms interval of the 2 ms timer, provided that interruption is permitted.

In the 2 ms timer interruption operation, all other interruptions are inhibited. Then, a present value is inputted from the AF pulse counter to be stored in the lens RAM 61b, and present distance code data is inputted from the distance code plate 81 to be stored in RAM 61b (S303, S305). If desired, an AF pulse number is corrected, and the present distance code is stored in the lens RAM 61b as previous distance code, at a different address, for the next 2 ms timer interruption operation (S307, S309).

The present zoom code is read from the zoom code plate 71 and stored in the lens RAM 61b as a present zoom code. The process inputs the state of zoom mode changing switch 77 and the state of the zoom speed

changing switch 75 (S311, S313). The process proceeds to a DZ operation when the powered zoom mode is selected, and to a MZ operation when the manual zoom mode is selected (S315).

DZ OPERATION

The DZ operation and MZ operation shown in FIG. 10 are flowcharts regarding an electrically driven (powered) zoom operation and manual (hand operated) zoom operation, respectively. These operations are performed by the lens CPU 61.

In the powered zoom (DZ) operation, an end point detection operation to identify if the group of zooming lenses 53Z has reached the end point thereof is performed (S351).

Flags for controlling the motor, etc. are set depending upon the zoom mode changing switch 75 and control flags, such as flag F_MOVTRG, F_MOV, etc. PZ pulse, and present value of the focal length are inputted to be stored in RAM 61b. If desired, the PZ pulse is corrected. When the present position of the group of zooming lenses 53Z is unknown, a position initializing operation (PZ-INITPOS) to the group of zooming lenses 53Z is performed, and the zoom code is stored at a different address as a previous zoom code in preparation for the next 2 ms timer interruption operation (S353, S355, S357).

If the constant image magnification zoom mode (F_ISM=1, i.e., ISZ operation) is selected, an ISZ memory operation is performed and the state of zoom switch 75 and 77 is stored in preparation for the next 2 ms timer interruption operation (S357-S361). According to the flag set in step S353, a drive control for the zoom motor 65, set-up of interruption bit-flag, duty ratio up operation for PWM control are performed. If a PWM control is conducted, a PWM timer is started (S363). Then, the process permits interruption and returns to the step concerned (S395).

In the manual zoom (MZ) subroutine, the zoom motor 65 is first stopped, the LED of the PZ pulser 69 is turned off, battery request (electricity demand) flag F_LBTREQ is cleared, and the bit of each of the PZ lens state PZ_LST data is cleared (S371, S373, S375, S379).

Data regarding PZ control stored in lens RAM 61b at a given address is cleared, and a zoom code is stored in preparation for the next 2 ms timer interruption operation. The PZ pulse number, roughly detected from the zoom code, is stored in lens RAM 61b as the present value of PZ pulse (PZPX), and a start value of the PZ pulse (PZPSTRT) and PZ pulse counter (PZPCNT) is cleared. The present value of the PZ pulse, as roughly detected, is converted into a present focal length (rough data) to be stored in the memory (S383, S385, S387).

The state of zoom switches 75 and 77 is stored in preparation for the next 2 ms timer interruption operation. Then, the 2 ms timer is started to allow the 2 ms timer interruption and to inhibit an interruption of INT3 (PZ pulse count) and INT 2 (PWM) in steps S389 through S393. The process permits another interruption and returns to the step concerned (S395).

METHOD FOR CONTROLLING PWM

PWM control method will be explained below on the basis of the flow chart shown in FIGS. 11 to 13. FIG. 11 shows the portion of the 2 ms timer interruption routine, shown in FIGS. 9 and 10, which relates to PWM control. FIG. 12 shows the portion of the PZ pulse count

interruption routine shown in FIGS. 95 and 96, which relates to a PWM control. FIG. 13 show a PWM interruption routine (brake operation) during the PWM control. The relationship between the main flow of FIG. 6 and various interruption routines will be explained hereinafter. It is possible to interrupt, by one of the communication interruptions (2 ms timer interruption or PWM interruption), the loops of main flows steps S127-S131 and S131-S157 shown in FIG. 6. It is also possible to effect the interruption by one of the 2 ms timer interruption, PZ pulse count interruption or PWM interruption in the communication interruption routine. In PWM the control, the speed is controlled by increasing or decreasing a ratio (PWM duty ratio T_PWMBRK) between a period of time in which power is supplied and a period of time in which power is not supplied. In other words, according to the illustrated embodiment, a constant speed control is realized by increasing a PWM duty ratio (T_PWMBRK) so as to prolong a power supply time to the zoom motor 65, when a PZ pulse is not detected within a predetermined period of time, thereby making the control speed higher, or by decreasing the PWM duty ratio (T_PWMBRK) so as to shorten the power supply time to the zoom motor 65 when the PZ pulse is detected within a predetermined period of time, thereby making the control speed slower (see FIG. 14).

In the illustrated embodiment, upon starting (i.e., when the motor is brought into actuation from its stopped state or braked state), the duty ratio is set at a minimum (i.e., a shortest power supply time), and then, the zoom motor 65 is supplied with power to count pulses outputted from the PZ pulser 69. When no pulses are outputted within a predetermined period of time, the duty ratio is gradually increased. When pulse is output within the predetermined period of time, the duty ratio is decreased. Thus, the zoom motor 65 is driven under an acceleration control or constant speed control, so that pulses are outputted at a preset time, period or cycle. Also, by setting the duty ratio at the minimum when the motor is actuated, it enables the photographer to effect a very smooth zooming operation.

The process first checks if the zoom motor 65 is to be actuated (if flag F_START is set) in S401. If it is to be actuated, PWM timer T_PWM is cleared and the PWM duty ratio T_PWMBRK is set at the minimum value (lowest speed), so as to actuate the zoom motor at the lowest speed. Then, the process proceeds to step S405. If the motor is not to be actuated, the process proceeds to step S405 without performing any operations (S401, S403).

In step S405, a process set pulse duration (pulse period P_PWMPLS) in accordance with the speed set by the zoom speed changing switch 75, etc. so as to supply electricity to the zoom motor 65 (S405, S407). This means that the zooming speed is controlled so that the PZ pulse is outputted at a pulse duration T_PWMPLS.

The process checks if the PWM drive mode or the DC drive mode is suited to the zooming speed. If the PWM drive mode is selected, the process proceeds to step S411. If, however, the DC drive mode is selected, the process will be returned (S409). In step S411, one increment is added to the PWM timer T_PWM. The process checks if such value, having been increased by one increment, exceeds the pulse period T_PWMPLS. If exceeded, the PWM duty ratio (T_PWMBRK) is increased, and if not exceeded, no operation is per-

formed (S413, S415). That is, if the PZ pulse is given within a predetermined period of time (T_PWMPLS), the PWM duty ratio (T_PWMBRK) is increased to prolong the power supply time, thus prescribing a high speed operation to the preset speed.

The process will be completed after setting the PWM duty ratio (T_PWMBRK), starting the PWM timer and permitting an interruption of the 2 ms timer (S417, S419). It should be noted that steps S407-S419 correspond to times (A), (C) and (D) in FIG. 14, respectively.

When a PA pulse is outputted from the PA pulser 69, the process enters a PZ pulse count interruption operation shown in FIG. 12. In the PZ pulse count interruption operation, the pulse period (T_PWMPLS) is compared with PWM timer T_PWM. If the pulse period (T_PWMPLS) is larger than the PWM timer, a pulse is outputted within the pulse period T_PWMPLS and thus, the PWM duty ratio T_PWMBRK is decreased and the PWM timer T_PWM is cleared. If the pulse period T_PWMPLS is less than the PWM timer, a pulse is outputted after one pulse period T_PWMPLS, so that the PWM timer T_PWM is cleared to complete the process at this time (S421, S423, S425).

In a PWM interruption routine shown in FIG. 13, the process inhibits an interruption, and breaks the zoom motor 65 so as to inhibit the interruption of INT2 (PWM), while allowing another interruption, and the process is returned. The operation in the above corresponds to time (B) in FIG. 14.

In the PWM control according to this embodiment, the pulse period T_PWMPLS is set at three stages, i.e., a low speed of 8, a medium speed of 4, and a high speed of 3, depending upon the speed designated by the zoom speed changing switch 75 etc. The PWM timer T_PWM is cleared when the motor is actuated and when the process transfers to the PZ pulse count interruption operation upon receipt of the PZ pulse outputted from the PZ pulser 69. Thereafter, the PWM timer is counted-up in the 2 ms timer interruption routine at S411, until after the PZ pulse is outputted. Accordingly, the PWM timer T_PWM indicates a time which is a multiple of the time elapsed since the previous PZ pulse was outputted. It should be noted, however, that the duration of the PZ pulse is greater than the period of 2 ms timer interruption, even in a high speed mode.

For example, when the high speed of 3 is assigned (i.e., pulse duration T_PWMPLS=3), the time period that elapses since the previous PZ pulse was outputted is $2\text{ ms} \times 3 = 6\text{ ms}$. When low speed of 8 is assigned, T_PWMPLS will be 8. The operation during the low speed will be explained with reference to the flow charts illustrated in FIGS. 11 and 12. If, in step S413 of the 2 ms timer interruption, it is determined that the pulse period T_PWMPLS is smaller than PWM timer T_PWM, i.e., when it has been passed more than $2\text{ ms} \times 8 = 16\text{ ms}$ has passed since the previous PZ pulse was outputted, the process proceeds to increase the PWM duty ratio (S415).

On the other hand, and in the PZ pulse count interruption operation, if it is determined that the pulse period T_PWMPLS is larger than the PWM timer T_PWM during the check in step S421, the PZ pulse is outputted before $2\text{ ms} \times 8 = 16\text{ ms}$ has passed after the previous PZ pulse was output. Accordingly, the PWM duty ratio is decreased (S423).

As shown above, a constant speed control, in which the PZ pulse duration is kept constant is made possible, by increasing or decreasing the duty ratio

(T_PWMBRK) of the PWM so that the PZ pulse is outputted at a predetermined pulse cycle or period (T_PWMPLS). The PZ pulse duration, and thus control speed, may be changed by changing the pulse period T_PWMPLS to be set.

CONSTANT IMAGE MAGNIFICATION RATIO ZOOMING

Constant image magnification zooming (IZS) now be explained. Constant image magnification zooming is a control in which an image magnification ratio m represented by $m=f/D$ may be kept constant regardless of a variation in an object distance, wherein the object distance and a focal length are represented by D and f , respectively.

First, the principle of constant image magnification zooming will be explained. For clearer illustration, the zoom lens constituted by two lens groups of a first group and a second group will be used in the explanation. Image magnification ratio m of the zoom lens is given by equation (1) below.

$$m_1 = x/f_1$$

$$m_2 = f/f_1$$

$$m = m_1 * m_2 = x * f / f_1^2$$

wherein;

m : image magnification ratio

$m_1(m1)$: magnification ratio of the first group

$m_2(m2)$: magnification ratio of the second group

f : composite focal length

$f_1(f1)$: focal length of first lens group

x : amount of advancement of the first lens group from ∞ end (amount of displacement)

The amount of advancement upon setting an image magnification ratio $x_0(x0)$, focal length $f_0(f0)$, and image magnification ratio $m_0(m0)$ is given by:

$$m_0 = x_0 * f_0 / f_1^2$$

If a focal length f which satisfies the following equation (3) is found when the lens is displaced to x by means of a focusing operation, the image magnification ratio can be maintained constant.

$$m_0 = x * f / f_1^2$$

From equations (2) and (3),

$$x_0 * f_0 / f_1^2 = x * f / f_1^2$$

Thus, the focal length f , which is to be found, is given as follows:

$$f = x_0 * f_0 / x$$

If a defocus amount Δx at the lens advancement amount x is obtained by means of an AF macrometer, an objective focal length f can be calculated by:

$$f = x_0 * f_0 / (x + \Delta x)$$

The principle (theory) of constant image magnification ratio zooming is explained above. In a practical (applied) control, however, the amount of advancement of the lens is managed by the focal length code plate, AF pulser, etc. The AF pulser is designed so that it will

have a linear relationship with the amount of advancement of the lens.

Thus, the amount of advancement x , x_0 in equation (4) and (5) may be replaced with an AF pulse number from the ∞ end and a defocus amount with defocus pulse number.

An actual operational method in the illustrated embodiment will be explained below. In this embodiment, the lens CPU 61 performs constant image magnification ratio zooming (control zooming). The operation is performed on the basis of an image magnification ratio supplied from the camera body 11 or on the basis of object distance and focal length at a given instance.

(1) When image magnification ratio m_0 is sent from the body:

(i) a provisional set value, pulse number for advancement x_0 and focal length f_0 is obtained from m_0 .

$$\text{first, let } f_0 = |f_1|$$

let amount of advancement corresponding to x_0 be X , and using equation (2);

$$m_0 = X * f_0 / f_1^2$$

let AF pulse number per 1 mm of lens advancement amount be k ;

$$x_0 = X * k$$

from equation (8), (6) and (7), objective advancement pulse number x_0 is given as follow:

$$x_0 = m_0 * |f_1| * k$$

(ii) next, $x_0 f_0$ will be obtained; from equations (6) and (9), $x_0 * f_0$ is obtained as follows:

$$x_0 f_0 = x_0 * f_0$$

(iii) objective focal length f is obtained; f is obtained on the basis of present position (present advancement pulse number) x as follows:

$$f = x_0 f_0 / X$$

f is also obtained on the basis of defocal pulse number Δx as follows:

$$f = x_0 f_0 / (x + \Delta x)$$

(2) When f is to be obtained on the basis of an advancement pulse number x_0 stored in the lens RAM 61b and focal length f_0 ;

(i) $x_0 f_0$ will be obtained as the above x_0 and f_0 , using equation (10) as follows;

$$x_0 f_0 = x_0 * f_0$$

(ii) magnification ratio m_0 will be obtained by using equations (7), (8) and (10) as follows:

$$m_0 = x_0 f_0 / (f_1^2 * k)$$

(iii) objective focal length f is obtained as follows: f will be obtained in the same way as above (iii) in (1).

(iii) f_1 is data peculiar to the lens and is stored in ROM 61a.

ISZ OPERATION

A calculation operation regarding the constant image magnification ratio zooming (ISZ) of the embodiment based on the above described principle will be explained in detail with reference to flow charts shown in FIGS. 15 and 16. This operation is performed by the lens CPU 61.

The image magnification ratio is set by the zoom speed changing switch 75 or set-up switch (SL switch). This will be explained later in detail with reference to FIG. 90.

The ISZ operation is related to a calculation of the preset image magnification ratio and to calculation of focal length for maintaining the preset image magnification ratio. The focal length will be calculated in the case where focusing is required and the case where focusing is not required. In each case, the calculation is made by the photographing lens or camera body. When focusing is required, the focal length, image magnification ratio and objective lens advancement amount are calculated on the basis of an amount of advancement of the lens upon focusing. When focusing is not required, the image magnification ratio and objective lens advancement amount are calculated on the basis of defocus amount and present focal length.

The process first performs a communication inhibition (SEI) and checks certain flags (F_STIS, F_ISZM, F_ISZFOM, F_ISZXOM) in order to determine the way in which the ISZ operation is being performed, on the basis of communication information transferred from the camera body 11 (S451, S453, S465, S477, S479). These flags indicate that communication regarding ISZ has been performed in relation to the camera body 11. In each communication, the flag is set (stored) in RAM 61b. The required operation or calculation will be made on the basis of the flags.

F_STIS is a flag to indicate that data transferred from the body is to be used; F_ISZM is a flag to indicate that data from the photographing lens is to be used; F_ISZFOM is a flag to indicate that focal length f data is to be used; and, F_ISZXOM is a flag to indicate that object distance x data from the body is to be used.

When the constant image magnification ratio zooming is performed on the basis of the image magnification ratio sent from the camera body 11 (F_STIS=1), communication interruption is permitted (CLI), $x_0 \times f_0$ is obtained from the above equations (6), (9) and (10) to be stored in RAM 61b at a predetermined address, and an interruption is inhibited so as to clear flag F_STIS (S455-S463).

In the case, where the image magnification ratio has been stored and a constant image magnification ratio zooming is performed on the basis of the focal length and object distance stored in the memory (F_STIS=0, F_ISZM=1), interruption is permitted, $x_0 \times f_0$ is calculated from the above object distance (advancement pulse number) x_0 and focal length f_0 , the image magnification ratio m_0 is calculated using equation (13) so as to be stored in RAM 61b at a predetermined address, the communication interruption is inhibited, and flag F_ISZM is cleared (S465-S475).

In the case where constant image magnification ratio zooming is performed on the basis of focal length f_0 sent from the camera body 11 and object distance (advancement pulse number) x_0 (F_STIS=0, F_ISZM=0 and ISZFOM=1, F_ISZXOM=1), $x_0 f_0$ is first calculated on the basis of the focal length f_0 as received and object

distance x_0 so as to be stored in memory. Image magnification ratio m_0 is calculated from equation (13). Interruption is inhibited and flags F_ISZFOM, F_ISZXOM are cleared (S477-S489). In a case other than the above, it is noted that no communication regarding operation is conducted in relation to the camera body 11. Accordingly, no operation is performed in such a case.

Then, flag F_PREOK is checked so as to determine if a predictor amount already sent from the camera body is effective. If it is effective, flag F_FPPE is set-up. Otherwise, flag F_FPPE is not set-up (S491-S493).

Checking is done as to whether the mode is the ISZ zooming mode. If the mode is the ISZ zooming mode, the current flag is checked if it is a flag (F_AFPOS=1) which recognizes the position of the present focusing lens 53F (object distance). If the position of the present focusing lens is known (F_AFPOS=1), the process proceeds to the FPPE-OP operation, in which control is performed using predictor amount, otherwise, the process passes through the ISZ operation (S495, S497).

If the mode is not the controlled zooming mode, flags F_FPPEOK, F_FPPE, F_ISOK are cleared. Then, the content at a predetermined address (LNS_INF1) and logical sum of each of the bits (0000111B) are stored at a predetermined address (LNS_INF1). Thereafter, the process passes through the ISZ operation (S495, S498, S499).

FPPE-OP OPERATION

The FPPE-OP operation shown in S501-S513, in which objective focal length f is obtained on the basis of a predictor amount, will be explained with reference to the flow chart shown in FIG. 17. This process is performed by the lens CPU 61 when the predictor amount is sent from the camera body 11 during a communication of the CPU with the camera body 11 (during this communication, flag F_FPPE is stored (memorized) in RAM 61b), or when steps S453 S463, S465-S475 or S477-S489 are performed to change or modify $x_0 f_0$ values by the communication of the CPU with the camera body 11 regarding ISZ and flag F_FPPE is set in S491-S493. Flag F_FPPE is a flag which determines whether the calculation ($f = x_0 f_0 / (x + \Delta x)$) to obtain objective focal length f based on a predictor amount is performed.

When entering this operation, the process checks if flag F_FPPE is set so as to determine whether the operation based on predictor amount is to be performed (S501). If flag F_FPPE is not set, the process jumps to S515. Otherwise, the process proceeds with the following operation.

First, F_FPPE is cleared and a communication interruption is inhibited. Objective focal length f is calculated from equation (12), utilizing predictor amount, and communication interruption is inhibited (S503-S509). Then, the objective focal length f is transformed to the objective PZ pulse number from a WIDE end so as to be stored in RAM 61b at a predetermined address (PZFPPE). Flag F_FPPEOK, which indicates that the operation based on the predictor amount is effective, is set. Then, the process proceeds to step S515 (S511, S513).

S515-S521 are steps in which the objective focal length f is calculated on the basis of present AF pulse (advancement pulse number).

In S515, permission of interruption (CLI) is performed. The objective focal length f is calculated using equation (11) so as to be stored in RAM 61b at a predetermined address (ISZ_FL,H) and then inhibition of interruption (SEI) is performed (S515, S517). The objective focal length f calculated in the above is transformed into an objective PZ pulse from the WIDE end. The transformed pulse value is stored in RAM 61b at a predetermined address (PZPF) in S519, S521.

The content of bits 3 through 7 of LNS_INF1, calculated in S529, will be explained below. LNS_INF1 is information which is periodically sent from the lens to the camera body by means of communication. Bits 3 through 7 are information regarding ISZ mode.

Bits 6 and 7 are flags which indicate whether an objective PZ pulse (PZPFPRE or PZPF) obtained by the ISZ operation is positioned on the WIDE side or TELE side with respect to the present PZ pulse. If the objective PZ pulse is positioned on the WIDE side, bit 7 is set, and if it is positioned on the TELE side, bit 6 is set. If the objective PZ pulse is between the WIDE side and TELE side, neither bit 6 nor 7 is set.

Bits 3 through 5 indicate, by $\frac{1}{3}$ segments, an approximate value which is the difference between the objective PZ pulse number and pulse number of the present position, i.e., PZ pulse number required for the lens to move from the present position to the objective position, divided by the total PZ pulse number (i.e., PZ pulse number required for the lens to move from the WIDE end to the TELE end). Bits 3, 4 and 5 are weighted by $\frac{1}{3}$, $\frac{1}{4}$ and $\frac{1}{5}$, respectively. The above value will be zero when the present position is equal to the objective position. Thus, bits 3 through 5 are all cleared. If the present position is at the WIDE end and the objective position is at the TELE end, or vice versa, the value will be $\frac{1}{3}$ and therefore bits 3 through 5 are all set at "1".

Thus, the camera body 11 receives, in LSN_INF1, periodically or upon request for information from the photographing lens 51, so that the camera body is able to send appropriate ISZ control information to the photographing lens 51.

The process checks if the operation based on predictor amount is effective (F_REOK=1). If effective, objective PZ pulse number (PZPFPRE), obtained by using predictor amount, is stored in accumulator (ACC). If not effective, objective PZ pulse number (PZPF) obtained on the basis of present AF pulse number is stored in the accumulator (S523, S525, S527).

Then, the values of bits 3 through 7 in LNS_INF1 are calculated on the basis of the objective PZ pulse number stored in the accumulator. The calculated values are stored in RAM 61b at a predetermined address (i.e., bits 3 through 7 of LNS_INF1) and an interruption inhibition operation (SEI) is performed (S529, S531).

The following operation is performed, provided that constant image magnification ratio zooming is selected, that position (focal length) of the present group of zooming lenses 53Z is obtained (flag F_PZPOS=1), and that constant image magnification ratio zooming is being performed (flag F_ISOK=1). If any one of the above conditions is not satisfied, the process jumps to step S551 (S533-S537).

If operation of the objective focal length based on the predictor amount (PZ pulse number) is effective (flag F_FPREEOK=1), and control flag for ISZ is set up (flag F_ISZD=1), the PZ pulse number obtained by

using predictor amount (from equation (11)) is stored in RAM 61b at a predetermined address (PZPTRGT) as objective pulse number (S539, S541, S543). If, however, the operation of the objective focal length based on the predictor amount is not effective (F_FPREEOK=) or ISZ control flag is cleared, the PZ pulse number obtained on the basis of AF pulse of the present position (advancement pulse number) using equation (12) is stored in the above predetermined address (PZPTRGT) in S539, S541 and S545. Flag F_ISZD is data which is sent from the body 11 by means of communication and stored in RAM 61b. If F_ISZD=1, ISZ control is performed on the basis of the calculated value based on the predictor amount. If F_ISZD=0, ISZ control is performed on the basis of the calculated value based on the present position of AF pulse.

Zoom speed data (bit 6, 7 of BD_ST1) sent from the camera body 11 and stored in RAM 61b is stored in RAM 61b at a predetermined address (bit 2, 3 of SPDDRC2). Constant image magnification ratio zooming flag F_ISZ is set up and interruption is permitted. Then, the operation is returned (S547, S549, S551). Constant image magnification ratio flag F_ISZ indicates that the CPU 61 has completed calculating the distance of the target focusing point, and that preparations for the motor and the zoom lens to be driven have been made. When the constant image magnification ratio flag F_ISZ has been set, a constant image magnification ratio zooming operation is performed in the 2 ms timer interruption routine. The values of PZPTRGT, SPDDRC2 are also used in the 2 ms timer interruption routine.

INSTRUCTION OPERATION

An instruction operation to be performed in the photographing lens 51 when instruction codes (command) are received from the camera body 11 will be explained below with reference to flow charts shown in FIGS. 19 to together with Tables 1 and 2 indicating the content of instruction codes. The instruction codes are details of S217 in communication interruption routine of FIG. 8. Each instruction operation is performed depending upon the lower bits of the command.

A STANDBY command is a command to cause the lens CPU 61 to be brought into a sleep mode. A flow chart regarding an operation upon input of the STANDBY command is shown in FIG. 19.

The lens CPU 61, upon receipt of the STANDBY COMMAND, sets up flag F_STNDBY, transmits a command receipt completion command to the body 11, allows communication interruption and is returned (S601, S602, S603). Lens CPU 61 checks flag F_STNDBY in the main routine at step S143. If flag F_STNDBY is set up, lens CPU stops clock 91 and is transferred into a low power consumption mode (standby mode) (See FIG. 7).

An AF-INTPOS command is a command which is sent after the camera body 11 has displaced the focusing lens 53F to ∞ end by means of AF motor 39. This command is an initializing operation command for AF to clear an AF pulse counter of the photographing lens 51. A flow chart regarding an operation performed by lens CPU 61, when the AF-INSTPOS command is inputted is shown in FIG. 20.

Lens CPU 61, when AF-INITPOS command is inputted, inputs distance code data from distant code plate 81 (S611). If the code data corresponds to the ∞ end (far end), AF pulse present position data (AFPXL,

H) in RAM 61b and F pulse start position data (AFPSTRTL, H) are cleared. A flag to identify that the present position of focusing lens 53F is known F_F-POS is set up and the process proceeds to S615. If the code data does not correspond to the ∞ end, the process skips through the above step and proceeds to S615. The process outputs command receipt completion command to body 11, allows communication interruption and is returned (S615, S616).

A PZ-INITPOS command is a command which causes the lens CPU 61 to perform an initialization operation so as to identify the zooming position. In this embodiment, the PZ pulse number corresponding to the code of the zoom code plate 71 is set in the PZ pulse counter when the zoom motor 65 is actuated, to detect boundary 72 of the code of the zoom code plate 71. A flow chart regarding an operation performed when the PZ-INITPOS command is inputted is shown in FIG. 21. The operations, such as the counting of PZ pulse, will be explained later in a POS-NG OPERATION shown in FIG. 86.

Lens CPU 61, when PZ-INTPOS code is input, clears flag F_PZPOS, sets up flags F_LBATREQ, F_IPZB and F_MOV, stores a predetermined data (lowest speed, direction TELE) in lens RAM 61b at SPDDRC1, and sets PZPA2B of the PZ pulse counter to zero. The PZ pulse counter counting PZ pulse from the present position to the code boundary (S621-S624). The process outputs a command receipt completion signal, allows communication interruption and is returned (S625-S626). The initializing operation regarding power zooming (PZ) is performed on the basis of the above value during the 2 ms timer interruption operation.

A RETRACT-PZ is a command which effects power zooming of the photographing lens 51 to minimize the length of (i.e., retract) the photographing lens barrel, when, for example, the main switch of the camera body is turned OFF. A flow chart regarding an operation upon input of the RETRACT-PZ command is shown in FIG. 22.

Lens CPU 61, upon receipt of the RETRACT-PZ command, stores present focal length data in RAM 61b at a predetermined address (RETPOS L,H), set PZ pulse data by which length of lens barrel becomes minimum (data inherent to the lens) in RAM 61b at a predetermined address, and set predetermined data (maximum speed) in SPDDRC2 (S631, S632, S632-2). The Lens CPU also sets each flag F_LBATREQ, F_IPZB and flag F_MOVTRG, sends a command receipt completion signal, and permits communication interruption. The process is then returned (S634-S636).

The focal length data before retraction (accommodation) is sent to the camera body 11 by means of a separate communication command (FOCALLEN-X, which will be explained hereinafter). Flag F_BATREQ is a flag which asks for electric supply to the power zoom lens 51 for the power zooming operation thereof, flag F_IPZB is a flag which indicates that zooming control (ISZ, PZ-INITPOS, etc.) is being conducted in the lens, and flag F_MOVTRG is a flag which moves zooming lens 53Z to an objective pulse position stored in address PZPTRG in the 2 ms timer interruption operation. Accommodation operation regarding the zooming lens 53Z is performed in the 2 ms timer interruption routine on the basis of the above set value.

RET-PZPOS is a command which returns the zooming lens from its retracted state to the state before it is

retracted. In other words, it is a command to return the zooming lens 53Z to its state before retraction or accommodation, for instance, when the main switch of the camera body SWMAIN is turned ON (to the position of focal length before retract power zooming is performed). A flow chart showing an operation upon input of the RET-PZPOS command is shown in FIG. 23.

When the lens CPU 61 receives the RET-PZPOS command, the lens CPU 61 sets the focal length data, which is one of the data items stored in the address, before retraction, designated by the code of the command and which is sent immediately before retract power zooming, at a predetermined address (FCLL, H) of the lens RAM 61b (S641). It should be noted that, focal length data stored before retraction sent from the camera body 51 by means of separate communication command is stored in address RETPOS,L,H.

The above focal length data is converted into an objective pulse number and stored in RAM 61b at a predetermined address as objective pulse number PZPTRG. A predetermined PZ speed data (high speed) is stored in SPDDRC2. Flags F_BATREQ, F_IPZB, F_MOVTRG are set. Command receipt completion signal is transmitted and communication interruption is permitted. The process is then returned (S642-S646). It is noted that the return operation is also performed in the 2 ms timer interruption operation.

IPZ-STOP is a command which stops the power zooming operation. This command is a command which stops controlled power zooming such as ISZ (constant image magnification), PZ-INITPOS (return), RETRACT-PZ (retraction or accommodation). It is not a command to stop a manual power zooming. A flow chart regarding an operation upon input of the IPZ-STOP command is shown in FIG. 24.

Lens CPU 61, when the IPZ-STOP command has been inputted, clears flag F_ISOK, together with flags (F_MOVTRG, F_MOV, F_ISZ) regarding performance of power zooming operation (S651, S652). Lens CPU 61 outputs command receipt completion signal and permits communication interruption and the process is then returned (S653, S654). Since the above flags are cleared, controlled power zooming such as ISZ (i.e., other than manual power zooming) is not performed in the 2 ms timer interruption operation.

ISZ-MEMORY is a command which stores present values of AF pulse and focal length in order to perform constant image magnification zooming. A flow chart regarding an operation upon input of ISZ-MEMORY command is shown in FIG. 25.

When an ISZ-MEMORY command is inputted, lens CPU 61 stores present value (AFPXL,H) of AF pulse counter in ISZAF pulse memory (ISZ_AFPL,H) in lens RAM 61b at a predetermined address. Lens CPU stores present value (FCLXL,H) of focal length in the ISZ focal length memory (ISZ_FCLL,H) (in lens RAM 61b at a predetermined address) in steps S661, S662. Flag F_ISZM is set, the command receipt completion command is outputted, and communication interruption is permitted. The process is then returned (S663-S665). On the basis of the above values, operation of ISZ indicated by S465-S475 in FIG. 15 is performed.

ISZ-START is a command which starts constant image magnification zooming. A flow chart regarding an operation upon input of the ISZ-START command is shown in FIG. 26,

When the ISZ-START command is inputted, lens CPU 61 sets flags F_LBATREQ, F_IPZB, F_ISOK and outputs a data transmission completion signal. Communication interruption is permitted and the process is returned (S671-S673). On the basis of the above values, the 2 ms timer interruption operation and operations at and after S537 in FIG. 18 will be performed.

BL COMMAND SUBROUTINE

Operation in photographing lens 51 upon receipt of BL command from camera body 11 will be explained with reference to FIGS. 27 to 37. The BL command communication operation is similar to that performed in the instruction command subroutine, except that the command receipt completion signal is first outputted, then data is inputted, and the inputted completion signal is outputted. BL command is a detail of S213 in the communication interruption subroutine of FIG. 8. Each command operation is performed depending upon the content of lower bits of the command.

PZ-BSTATE (20) is a command which sends necessary data to IPZ (constant image magnification ratio zooming). The data sent by this command includes data which indicates the status of focusing lens 53F, i.e., whether the lens is at the far end (infinite end) (F_ENDF=1) or the near end (closest end) (F_ENDN=1), in far move (F_FARM=1) or near move (F_NEARM=1), whether the lens is in overlap integration (F_OVAF=1), whether it is in a moving object prediction mode (F_MOBJ=1), whether it is in a focusing state (F_AFIF=1), whether an image magnification ratio should be stored by means of command (communication) from the body or by means of judgement of the lens CPU 61 (F_ISM=1), etc. A flow chart regarding an operation upon receipt of the PZ-BSTATE command is shown in FIG. 27.

When the PZ-BSTATE command is inputted, lens CPU 61 sends command receipt completion signal, inputs PZ-BSTATE data of 1 byte from camera body 11, and performs subroutine CNTAFP regarding an AF pulse count operation (S701-S703). Detail of the CNTAFP subroutine is shown in FIGS. 39 to 43, which will be explained hereinafter.

Data input completion signal is outputted and communication interruption is permitted. Then, the process is returned (S704, S705). The camera according to this embodiment has an AF drive source mounted to the body 11. Accordingly, when the AF pulse is counted in lens 51, driving direction information of AF, etc. is always sent from body 11 to lens 51 by means of this command, before actuating AF and after changing driving direction.

BODY-STATE0 is a command which informs the photographing lens of data regarding the state or condition of the body. This command is sent during periodical communication between the photographing lens and camera body. A flow chart regarding an operation upon receipt of the BODY-STATE0 command is shown in FIG. 28.

When the BODY-STATE0 command is inputted, lens CPU 61 sends a command receipt completion signal, and inputs data (BODY-STATE0) of 1 byte regarding the status of the body 11 from the body so as to store the data in lens RAM 61 at BD_ST0 (S711-S713). When the upper 5 bits of the above 1 byte data are masked and stored in lens RAM 61b at ZM_MODE, a data input completion signal is outputted and communi-

cation interruption is permitted. The process is then returned (S714-S716).

In the lower 3 bits, BODY-STATE0 data includes information regarding power zooming mode of the camera body 11, such as, constant image magnification ratio (ISZ), during-exposure (EXZ), manual power zooming (MPZ), etc. BODY-STATE0 data includes, in the upper 5 bits, information regarding the ON/OFF status of an electric source of the body circuit system (F_VDD=1), the ON/OFF status of the photometric switch (F_SWS=0), supply of electricity from the body 11 to the zoom motor (F_BATT=1), AF/MF changing switch of the body 11 being AF or MF (F_SWAF), and the mode of AF being single or continuous (F_MAF).

BODY-STATE1 is a command which sends data regarding the status of the camera body 11, similar to those in BODY-STATE0 command. This command includes information regarding the status of sequence of operations of the camera body 11. A flow chart regarding an operation upon receipt of BODY-STATE1 command is shown in FIG. 29.

Upon receipt of the BODY-STATE1 command, the lens CPU 61 sends a command receipt completion signal and inputs data (BODY-STATE1) of 1 byte from the body 11 so as to store them in lens RAM 61b at BD_ST1 (S721-S723). If flag F_IPZD is set, flags F_ISOK, together with flags F_MOVTRG, F_MOV, F_ISZ of address BD_ST1 is cleared. If flag F_IPZD is not set, the above operation is not performed (S724, S725, S726). A data input completion signal is outputted, and then communication interruption is permitted. Finally, the process is returned (S724, S727, S728).

The operation to be performed when flag F_IPZD is set is an operation similar to the IPZ-STOP command of instruction code 35. This command causes the lens CPU 61 to receive information regarding the body and to perform the IPZ-STOP command. Flags relating to the command will be explained below.

F_IPZD is a flag which identifies whether an operation similar to IPZ-STOP is to be performed.

F_MPZD is a flag which identifies whether manual power zooming is to be inhibited. When F_MPZD is set, manual power zooming is inhibited. Flag F_MPZD is referred to during the 2 ms timer interruption operation.

F_ISZD is a flag which identifies whether ISZ is to be controlled on the basis of the AF pulse number of the present position (during focusing) or on the basis of the focal length obtained from the predictor amount. This flag is referred to during a subroutine of ISZ (S541 in FIG. 18).

F_ISSPA and F_ISSPB are flags which identify the control speed of ISZ and are referred to in S547 in FIG. 18.

A flow chart regarding an operation upon receipt of SET-AFPOINT command is shown in FIG. 30.

Lens CPU 61 inputs SET-AFPOINT command (23), outputs a command receipt completion signal, receives SET-AFPOINT data of 1 byte from the body side, so as to set them in lens RAM 61b at a predetermined address, outputs a data input completion signal and permits a communication interruption. The process is then returned (S731-S735).

The SET-AFPOINT command is performed before communication of LB command and LENS-AFPULSE (15).

A LENS-AFPULSE command determines which AFPULSE is to be sent from lens 51 to body 11, depending upon information sent by SET-AFPOINT command.

When bit3 (X) is set, AF pulse (AFPULSE (AFPXL,H)) of the present position is sent.

When bit7 (ISZM) is set, AF pulse number (AFPULSE (ISZ_AFPL,H)), obtained when the image magnification ratio is stored during ISZ mode, is sent. It is to be noted that it is impossible for bit3 and bit7 to be set at the same time.

When neither bit3 nor bit7 is set, bits 4 through 6 (FM0, FM1, FM2) become effective.

8 segments (0-7) for memorizing AF pulse data are provided in the lens RAM 61b of lens CPU 61 (AFP0L,H-AFP7L,H). AF pulse data may be stored in respective segments by means of a command from the body 11. Three bits of bit 4 through 6 designate addresses 0 to 7. AF pulse data memorized in such addresses will be transmitted. This command only serves to designate one of the AF pulse data to be sent to the body 11 in LENS-AFPULSE (15).

A flow chart regarding an operation upon receipt of SET-PZPOINT command is shown in FIG. 31.

When SET-PZPOINT command (24) is inputted, the lens CPU 61 outputs a command receipt completion signal, receives SET-PZPOINT data from the body side and sets the same in the lens RAM 61b at a predetermined address, outputs a data input completion signal, and permits communication interruption. The process is then returned (S741-S745).

The SET-AFPOINT command is performed before communication of the LB command and FOCALLEN-X(16).

The LENS-AFPULSE command determines, on the basis of information sent by the SET-PZPOINT command, whether the focal length data of the present position or the focal length obtained when the image magnification ratio is memorized during the ISZ mode is to be sent to the body 11.

When bit3 (X) is set, focal length data (FCLXL,H) of the present position is sent.

When bit7 (ISZM) is set, focal length (focal length (ISZ_FCLL,H) of ISZ memory) obtained when the image magnification ratio is stored during the ISZ mode is sent. It is to be noted that it is impossible for bit3 and bit7 to be set at the same time.

When neither bit3 nor bit7 is set, bits 4 through 6 (FM0, FM1, FM2) become effective.

8 segments (0-7) for memorizing the focal length are provided in the lens RAM 61b (FCL0L,H-FCL7L,H). The focal length may be stored in respective segments by means of the SET-PZPOINT command from the body 11. Three bits of bit 4 0 through 6 designate addresses 0 to 7. The focal lengths memorized in such addresses will be transmitted. This command only serves to designate one of the focal lengths to be sent to the body 11 in FOCALLEN-X (16).

STORE is a command which sets predetermined AF pulse data at a designated address. A flow chart regarding an operation upon receipt of a STORE-AFP command is shown in FIG. 32.

Lens CPU 61, upon receipt of the STORE-AFP command (25), outputs a command receipt completion signal and inputs data of 2 bytes from the camera body 11 (S751, S752). If one of the bits is not ISZ memory (ISZM=0), the input data is stored in lens RAM 61b at address (AFP0L,H-AFP7L,H), designated by AM-

0-AM 2 of the data. If one of the bits is stored in ISL memory (ISZM=1), the input data is stored in the ISZ memory (ISZ-AFPL,H) of lens RAM 61b (S751-S756). ISZ operational flag F_ISZXOM is set, a data input completion signal is outputted, and communication interruption is permitted. The process is then returned (S757-S758).

STORE-DEFP&D (26) is a command which causes the lens RAM 61b to store a defocus amount and defocal pulse regarding the camera body 11. A flow chart regarding an operation upon receipt of the STORE-DEFP&D command is shown in FIG. 33.

Lens CPU 61, upon receipt of the STORE-DEFP&D command, outputs a command input completion signal, and inputs defocus pulse data of 2 bytes and defocus amount data of 2 bytes from the camera body 11. The inputted defocus pulse is multiplied by $\frac{1}{2}$ (S761-S764). In the illustrated embodiment, since the ratio of body AF pulse to lens AF pulse is 2:1, the input defocus pulse is multiplied by $\frac{1}{2}$. The ratio may be set as desired.

If flag F_SIGN has been cleared, the defocus pulse number is added to the present AF pulse number so as to store the added value in ISZ_FPX. If flag F_SIGN has not been cleared, the defocus pulse number is subtracted from the present AF pulse number and the subtracted value is stored in ISZ_FPX. When flag F_SIGN=1, the defocus amount is towards the FAR end, and when F_SIGN=0, the defocus amount is towards the NEAR end. Then, flag F_FPRES is set, a data input completion signal is outputted, and communication interruption is permitted. The process is then returned (S765-S771). Defocus pulse transmitted by means of communication as described above is used in the ISZ operation routine so as to obtain objective focal length by utilizing defocus pulse. Flag F_FREE is a flag which gives an indication to perform an operation using a predictor amount.

STORE-PZP (27) is a command which causes present AF position (position of focusing lens or focusing object distance) and present position of PZ (position of group of zooming lenses 53Z or focal length) to be stored in a designated memory (address).

STORE-PZF is a command which causes the focal length designated by camera body 11 to be stored at a predetermined address.

A flow chart regarding an operation upon receipt of the STORE-PZP command is shown in FIG. 34.

Lens CPU 61, upon receipt of the STORE-PZP command, outputs a command receipt completion signal and inputs data of 1 byte from the camera body 11 (S781, S782). If the PZ memory is designated (when the PZM flag is set), focal length data of the present position is stored in the address (FCL0L,H-FCL7L,H) designated by FM0-FM2, otherwise the focal length data is not stored (S783, S784).

If AF memory is designated (when AFM flag is set), an AF pulse number of the present position is stored in the address (AFP0L,H-AFP7L,H) designated by AM0-AM2. Otherwise, a data input completion signal is simply outputted, while permitting communication interruption. The process is then returned (S785-S788).

A flow chart regarding an operation upon receipt of STORE-PZF command is shown in FIG. 35.

Lens CPU 61, upon receipt of a STORE-PZF command, inputs data of 2 bytes from the camera body. If this command is not ISZ memory (if flag F_ISZM is not set), the inputted data of 2 bytes are stored in lens RAM 61b at address (FCL0L,H-FCL7L,H) designated

by bits FM0 FM2. If the command is ISZ memory (if ISZM is set), the inputted data is stored in ISZ memory and a flag F_ISZFOM, which performs an operation on the basis of a focal length, is set up (S791-S796). A data input completion signal is outputted and communication interruption is permitted. The process is then returned (S797-S798).

STORE-IS (29) is a command which causes the image magnification ratio memory (address ISZ-IMGL,H of lens RAM 61b) to store an image magnification ratio. A flow chart regarding an operation upon receipt of the STORE-IS command is shown in FIG. 36.

Lens CPU 61, upon receipt of the STORE-IS command, outputs a command receipt completion signal, inputs data of 2 bytes regarding an image magnification ratio from the camera body 11, stores the data in an image magnification ratio memory (ISZ-IMGL,H), and sets flag F_STIS (S801-S804). The data input completion signal is outputted and communication interruption is permitted. The process is then returned (S805-S806). Flag F_STIS is a flag which performs an operation of image magnification constant zooming in accordance with the image magnification ratio sent from the camera body.

MOVE-PZMD (2A) is a command which causes a power zooming in the designated direction or towards a focal length in the designated memory (address in lens RAM 61b).

MOVE-PZF (2B) is a command which performs power zooming to a designated focal length, for example, to a focal length calculated in the camera body 11. The data of this command includes data regarding focal length and zooming speed.

A flow chart regarding an operation upon receipt of the MOVE-PZMD command is shown in FIG. 37.

Lens CPU 61, when the MOVE-PZMD command is inputted, outputs a command input completion signal, and inputs data of 1 byte from the camera body 11 (S811-S812). If flag F_MDM is set in the input data, data is read out from the address (FCL0L,H-FCL7L,H) designated by MVM0-MVM2. The read out data is converted into PZ pulse data and stored in lens RAM 61b at PZPTRGT. Driving speed data (F_SPA, F_SPB of bits 6 and 7) is stored in SPDDRC2, and flag F_MOVTRG is set to 1. If flag F_MDM is not set, the upper 4 bits of the input data are stored in address SPDDRC1 and flag F_MOV is set (S813-S819). These data are referred to in the 2 ms timer interruption routine so as to perform power zooming in a designated manner.

When flags F_LBATREQ and F_IPZB are set, a data input completion signal is outputted and communication interruption is permitted. The process is then returned (S820-S820-2). If flag F_MDM (bit3) is set, the command is to perform power zooming toward the focal length stored in the designated memory. If flag F_MDM is not set, the command is to perform power zooming in a direction designated by flag F_MDT and F_MDW (bits 4 and 5). Flag F_MDT designates driving in the TELE direction, flag F_MDW designates driving in the WIDE direction, and flags F_SPA and F_SPB (bits 6 and 7) designate zooming speed.

A flow chart regarding an operation upon receipt of MOVE-PZF command is shown in FIG. 38.

When the MOVE-PZF command is inputted, the lens CPU 61 outputs a command receipt completion signal, inputs focal length data of 2 bytes from camera body 11,

converts input focal length data into PZ pulse data so as to store the same in the lens RAM 61b at address PZPTRGT, sets speed data in SPDDRC2, and sets flags F_BATREQ, F_IPZB, F_MOVTRG. These data are referred to in the 2 ms timer interruption routine so as to perform power zooming in a designated manner. A data input completion signal is outputted and communication interruption is permitted. The process is then returned (S821-S827).

CNTAF OPERATION

An AF pulse count operation in the photographing lens 51 will be explained below with reference to the flow charts shown in FIGS. 39 to 43. This count operation is a detail of an operation executed in S703 by means of the PZ-BSTATE command (20) shown in FIG. 27. In the illustrated embodiment, the value of the AF pulse counter is cleared (set to zero) when the focusing lens 53F reaches the FAR end (infinite photographing position). On the other hand a maximum value is set at the AF pulse counter when the focusing lens reaches the NEAR end (closest photographing position). In the case of a NEAR MOVE (driven toward closest distance), the AF pulse outputted from the AF pulser 59 is added thereto. In the case of a FAR MOVE (driven toward infinite), the AF pulse is subtracted therefrom.

Interruption is inhibited, data inputted during communication is stored at address PZ_BDST, and the present distance code is inputted from the distance code plate 81 (S901 S905).

If flag F_ENDF to identify a FAR END (infinite position) is set, it is determined if the inputted distance code is a code of the FAR END (S907-S909). If the distance code is the FAR END, the present AF pulse value and AF pulse count start value (address AFPZL,H, AFPSTRTL,H) are cleared and flag F_AFPOS is set up to indicate that the AF pulse of the present position is known (S909, S913, S915). If flag F_NEARM to identify NEAR MOVE is cleared, the process jumps to CNTAFP10 operation. If an F_NEARM flag is set, the process jumps to a CNTAFP11 operation, since the driving direction is to be changed (S917). If the detected distance code is not the FAR END code, far end flag F_ENDF is cleared and the process jumps to a CNTAFP3 operation (S909 and S911).

If the far end flag F_ENDF is cleared, the near end flag F_ENDN, which identifies the near end (closest focusing position) is checked. If the near end flag is cleared, the process proceeds to CNTAFP3 (S919).

If the near end flag F_ENDN is set, the process checks if the distance code is a near end code. If it is not a near end code, the far end flag F_ENDN is cleared and the process proceeds to a CNTAFP3 operation (S919-S923). If the distance code is the near end, the AF pulse count value and AF pulse count start value are set at a maximum (set N_AFMAXL,H at AFPXL,H, AFPSTRTL,H), flag F_AFPOS which identifies that the present AF pulse is known, is set. The process checks if the present status is a FAR MOVE (F_FARM=1). If it is a FAR MOVE, the process proceeds to a CNTAFP11 operation, otherwise the process proceeds to a CNTAFP10 operation (S925-S929).

As described above, in the case of the FAR END (F_ENDF=1) or NEAR END (F_ENDN=1), the count value of the AF pulse is corrected by the corresponding predetermined value. If the input distance

code is determined to be at neither of ends, the above end point correction is not performed.

An operation (CNTAFP3 operation) when the group of focusing lenses 53F is positioned between the FAR END and NEAR END will be explained with reference to a flow chart shown in FIG. 40.

First, a counter value, in a hard counter of the present AF pulse, is set in an AF pulse counter (AFPCNTL,H) in steps S931, S933. If flag F_FARM is cleared, the process proceeds to a CNTAFP6 operation. If F_FARM flag is set, it is checked if the previous status was NEAR MOVE (i.e., if flag F_NEARM0 is set) in steps S933, S935. If it is determined that the status has been changed from NEAR MOVE to FAR MOVE, an AF pulse count start value (AFPCNTL,H) is added to an AF pulse counter start value (AFPSTRL,H) so as to store it in the AFPXL,H and AFPSTRTL,H memory for present AF pulse value and AF pulse count start value. The process proceeds to a CNTAFP12 operation (S935, S937).

If the previous status was not a NEAR MOVE, it is determined if the previous status was a FAR MOVE. If it is not the FAR MOVE, i.e., the lens was not moved, the process proceeds to CNTAFP11. If the previous status was also a FAR MOVE, a count value (AFPCNTL,H) is subtracted from the AF pulse count start value (AFPSTRL,H) so as to store the difference in the present AF pulse value (AFPXL,H), since there is no change in driving direction. Then, the process proceeds to a CNTAFP6 operation (S939, S941).

The CNTAFP6 operation, when the present status is not a FAR MOVE, will be explained below with reference to the flow chart shown in FIG. 41. It is noted that the CNTAFP6 operation is the first operation that the process enters after start-up.

The process checks if the status is NEAR MOVE. If it is not NEAR MOVE, the process proceeds to a CNTAFP8 operation (S951). If it is NEAR MOVE, the process checks if the previous status was NEAR MOVE. If previous status was also NEAR MOVE, an AF pulse count value (AFPCNTL,H) is added to the AF pulse count start value (AFPSTRTL,H) so as to store the sum in present AF pulse value (AFPXL,H) in steps S953, S955.

If the previous status was not NEAR MOVE, but rather FAR MOVE, it is an indication that the driving direction is to be changed. Accordingly, AFP count value (AFPCNTL,H) is subtracted from the AF pulse count start value (AFPSTRTL,H) so as to store the difference in the AF pulse value and AF pulse count start value (AFPXL,H and AFPSTRTL,H) in steps S958, S959. If the status is not FAR MOVE, the process proceeds to a CNTAFP11 operation (S957).

An operation effective upon stopping of the AF motor (CNTAFP8 OPERATION) will be explained below with reference to a flow chart shown in FIG. 42.

In the CNTAFP8 operation, the process first checks if the previous status was NEAR MOVE (S961).

If the previous status was NEAR MOVE, this means that the lens was stopped during NEAR MOVE. Accordingly, an AF pulse count value (AFPCNTL,H) is added to the AF pulse count start value (AFPSTRTL,H) and the sum is stored in the AF pulse value and AF pulse count start value (AFPXL,H and AFPSTRTL,H). The process then proceeds to a CNTAFP10 operation (S961, S963).

If the previous status was FAR MOVE, this means that the lens was stopped during FAR MOVE. Accord-

ingly, an AF pulse count value (AFPCNTL,H) is subtracted from the AF pulse count start value (AFPSTRTL,H) so as to store the difference in present AF pulse value and AF pulse count start value (AFPXL,H and AFPSTRTL,H). The process then proceeds to a CNTAFP10 operation (S961, S965, S967).

If the previous status was not NEAR MOVE nor FAR MOVE, this means that the lens has been stopped. Accordingly, the process proceeds to a CNTAFP16 operation (S961, S965).

CNTAFP10, 11, 12, 16 operations will be explained below with reference to the flow chart shown in FIG. 43. The process enters CNTAFP10 just after the AF motor 39 has stopped. Accordingly, the LED of the AF pulser 59 is turned OFF, the content of PZ_BDST is stored in PZ_BDST0, and communication interruption is permitted. The process then passes through the AF pulse count operation (S971, S977, S979).

The process enters a CNTAFP11 operation upon the start of AF driving. Accordingly, the LED of AF pulser 59 is turned ON, an AF pulse hard counter and AF pulse count value memory (AFPCNTL,H) is cleared, contents of PZ_BDST memory is transferred to PZ_BDST0, and communication interruption is permitted. The process then passes through an AF pulse count operation (S973, S975, S977, S979).

The process enters a CNTAFP12 operation when driving direction is changed during the actuation of AF. Accordingly, the AF pulse hard counter and AF pulse count value (AFPCNTL,H) are cleared, the content of PZ_BDST memory is transferred to PZ_BDST0, and communication interruption is permitted. The process then passes through an AF pulse count operation (S975, S977, S979).

The process enters a CNTAFP16 operation or processing during movement in the direction of a NEAR MOVE or FAR MOVE (S655, S641), or when the AF motor is stopping (S965). Accordingly, contents of PZ_BDST is transferred to PZ_BDST0 and communication interruption is permitted. The process then passes through the AF pulse count operation (S977, S979).

LB COMMAND OPERATION

A operation regarding a command which has the power zoom lens 51 send the information of the lens, i.e., state of the lens, to the camera body, in accordance with the demand of the camera body, will be explained below with reference to table 4 and the flow charts shown in FIGS. 44 to 51. The content of the command is shown in Table 4. The flow charts shown in FIGS. 44 to 51 are details of an operation of S209 in a communication interruption routine shown in FIG. 8. An operation will be performed in accordance with the lower bits of the command.

PZ-LSTATE OPERATION

The flow chart shown in FIG. 44 illustrates PZ-LSTATE (10), by which data regarding power zooming control of the power zoom lens 51 is sent to camera body 11. Lens CPU 61, upon receipt of a command requiring a lens state regarding power zooming (PZ-LSTATE), outputs a command receipt completion signal and thereafter outputs data regarding the type of power zooming control, (for example, a constant image magnification ratio zooming control) to the camera body 11 (S1001, S1002). A data input completion signal

is outputted and communication interruption is permitted. The process is then returned (S1003, S1004).

Flags used in this operation will be explained below.

Flag F_TMOV (bit 0) is set when the zoom motor is moving in the TELE direction.

Flag F_WMOV (bit 1) is set when the zoom motor is moving in the WIDE direction.

Flag F_TEND is set when the group of zooming lenses 53Z is positioned at the TELE end.

Flag F_WEND is set when the group of zooming lenses 53Z is positioned at the WIDE end.

Flag F_IPZB is set when power zooming (initializing operation for ISZ, PZ, and retracting operation) is performed in a mode other than the manual power zooming.

Flag F_IPZI is set when manual power zooming is performed during ISZ operation.

Flag F_ISOK is set during ISZ operation.

Flag F_MPZI is set while manual power zooming is being performed.

POFF-STATE, POFFS-WSLEEP OPERATION

FIG. 45 illustrates a flow chart regarding a POFF-STATE (11) operation and POFFS-WSLEEP (12) operation. These operations serve to send to the body 11 information regarding power zooming of the lens, battery request information, monitor information of the electric source (battery) for Pz, etc. The difference between POFF-STATE (11) and POFFS-WSLEEP (12) resides in whether the lens CPU 61 enters a lower power consumption mode after completion of this command communication. When the POFFS-WSLEEP (12) operation is performed, flag F_STNDBY is set during the communication and lens CPU 61 proceeds to a low power consumption mode when returned to the main routine. That is to say, the POFFS-WSLEEP (12) command is a command which performs both the POFF-STATE (11) and STANDBY command (30) of the instruction code.

In the case of the POFFS-WSLEEP (12) command, the lens CPU 61 sets flag F_STNDBY, outputs command receipt completion signal, and inputs the condition of switches (75, 77). If flag F_STNDBY is set (in a case of POFFS-WSLEEP (12)), electrically driven/manual changing switch (D/M switch) is assigned to an electrically driven mode. At this time, if the TELE or WIDE switch (speed changing switch) is turned ON, the process sets the battery request flag F_BATREQ and proceeds to S1025. Otherwise, the process proceeds to S1025 (S1017, S1019, S1021, S1023).

If the flag F_STNDBY is set, the process normally completes this communication interruption and proceeds to a low power consumption mode after it is returned to the main routine. If, however, flag F_BATREQ is set, the process does not proceed to a low power consumption mode so that the manual power zooming operation is possible, even though flag F_STNDBY is set to perform the normal operation, (see FIG. 7).

When flag F_STNDBY is not set, the process will not proceed to a low power consumption mode, even though it returns to the main routine. Accordingly, operations such as a manual power zooming will be possible even if flag F_BATREQ is not set in this command, provided that PZ speed switch 75 is turned ON.

The process will proceed directly to S1025 if flag F_STNDBY is cleared (when POFF-STATE(11)).

In S1025, flags F_SLSW, F_ASSW, F_PZM, F_PZD, F_AFSW are set or cleared, depending upon the data of the zoom mode changing switch 77. The state of the VBATT terminal is monitored and if electric power for PZ is not supplied from the camera body 11, flag F_BDET is cleared (VBATT Otherwise, flag F_BDET is set (VBATT ON) in steps S1027-S1031. The data (POFF-ST) of 1 byte, as set above, is transmitted to camera body 11, a data input completion signal is outputted and communication interruption is permitted. The process is then returned (S1033-S1037).

When a POFF-STATE operation is performed, the process jumps to step S1013 while passing through flag F_STNDBY set operation in step S1011. Thereafter, operations similar to those of the POSFFS-WSLEEP operation will be performed.

LENS-INF1 OPERATION

A flow chart of LENS-INF1 shown in FIG. 46 illustrates an operation by which various information of lens 51 is sent to camera body 11.

Upon an input of a LENS-INF1 data request command, lens CPU 61 sends command receipt completion signal, clears 2 bits of LNS-INF1 data of 1 byte relating to the direction of power zooming, sets 1 bit to identify AE auto-lens, and inputs switch information of zooming direction (S1041-S1043). In response to the switch information that is inputted, the corresponding bit is set so as to send 1 byte lens data to camera body 11 (S1044, S1045). A data transmission completion signal is outputted, and communication interruption is permitted. The process is then returned (S1046 and S1047). It is to be noted that LNS-INF1 data includes data relating to constant image magnification ratio zooming. The detail of which is described above.

LENS-INF2 OPERATION

The flow chart of LENS-INF2, shown in FIG. 47, performs an operation by which fixed data inherent to lens 51 is sent to camera body 11.

Upon an input of a LENS-INF2 command, lens CPU 61 outputs a command receipt completion signal, outputs LNS-INF2 data to camera body 11, outputs a data input completion signal, and permits a communication interruption. The process is then returned (S1051-S1054). LENS-INF2 data includes data to identify lens type, and PZ lens and the data is fixed data stored in ROM 61a.

LENS-AFPULSE OPERATION

A flow chart of a LENS-AFPULSE shown in FIG. 48 is for an operation by which lens AF pulse count data is outputted to camera body 11.

As explained above, the SET-AFPOINT command communication is always performed prior to communication of the LENS-AFPULS command. The content of the SET-AFPOINT command determines the AF pulse which is to be sent to the body by means of LENS-AFPULSE command.

Upon an input of the LENS-AFPULSE command, lens CPU 61 outputs a command receipt completion signal, and, if a present AF pulse is required, stores the present AF pulse number (AFPXL,H) in a register (S1061-S1063). When a pulse of constant image magnification ratio zooming (ISZ9) is demanded, AF pulse data (ISZ-AFPL,H) of ISZ is stored in the register (S1062, S1064, S1065). In a case other than the above two cases, AF pulse data (AFP0L,H-AFP7L,H) of

designated address is stored in the register (S1062, S1064, S1066). Thereafter, AF pulse data, set in the register, is outputted to camera body 11, a data transmission completion signal is outputted, and a communication interruption is permitted. The process is then returned (S1067-S1069).

FOCALLEN-X OPERATION

A FOCALLEN-X operation by which focal length data of lens 51 is outputted to camera body 11 will be explained below with reference to a flow chart illustrated in FIG. 49.

As explained above, a SET-PZPOINT command communication is always performed prior to FOCALLEN-X command communication. A SET-PZPOINT command determines a focal length which is to be sent to the body upon receipt of the FOCALLEN-X command.

Upon receipt of the FOCALLEN-X command, outputs a command lens CPU 61 receipt completion signal, and stores the present focal length (FCLXL,H) in the register, if present focal length is required (S1071-S1073). When a focal length (ISZ-FCLL,H) for constant image magnification ratio zooming (ISZ) is required, a focal length (ISZ-FCLL,H) for constant image magnification ratio zooming is stored in the register (S1072, S1074, S1075). In a case other than the above two cases, a focal length (FCL0L,H-FCL7L,H) of designated address is stored in the register (S1072, S1074, S1076). The focal length data set in the register is outputted to camera body 11, a data transmission completion signal is outputted, and a communication interruption is permitted. The process is then returned (S1077-S1079).

IMAGE-LSIZE OPERATION

A flow chart of an IMAGE-LSIZE shown in FIG. 50 is for an operation by which an image magnification ratio data for performing a constant image magnification ratio zooming, stored in lens RAM 61b at a predetermined address, is sent to camera body 11.

Lens CPU 61, upon input of IMAGE-LSIZE command, outputs a command receipt completion signal to camera body 11, outputs data (ISZ-IMGL,H) relating to image magnification ratio (image size) to camera body 11, outputs a data transmission completion signal, and permits communication interruption. The process is then returned (S1081-S1085).

16 BYTE DATA PROCESSING

A 16 byte data flow chart shown in FIG. 51 is for an operation by which basic lens data of 16 bytes are all sent to camera body 11. It is to be noted that this command is a detail of the operation performed in the communication interruption routine of FIG. 8 at S221. Depending upon the lower bits of the command, each command will be performed. Processing of the first half 8 bytes and second half 8 bytes are similar to that of the 16 byte data communication and hence a detailed explanation is omitted.

Upon an input of a 6 byte command, outputs a command lens CPU 61 receipt completion signal to camera body 11, outputs a predetermined data (LC0-LC15) of 16 bytes to camera body 11, outputs a data transmission completion signal and permits communication interruption. The process is then returned (S1091-S1094).

PZ OPERATION FOR BODY

An operation relating to a power zooming at the side of camera body 11 will be explained below with reference to a flow chart shown in FIGS. 52 to 55. This operation or processing is performed by the main CPU 35 on the basis of a program stored in ROM 35a of the main (body) CPU 35 of the camera body 11.

The process first enters the operation of the main flow, when main CPU 35 is reset, such as when the main switch is turned ON (when the battery is inserted and electricity is generated). The process, when entering this operation, initializes RAM 35b, port setting, etc., inputs predetermined information by means of switch input or E2PROM DATA INPUT, and performs a power zoom initializing operation (PZINIT subroutine) (S1101, S1103, S1105). In this embodiment, a power zoom initialization is an operation by which initialization is done to the PZ lens and focusing lens, for the purpose of detecting positions of the zooming lens and focusing lens. The above steps are done upon initial input of power source (i.e., when a main switch which is not shown is turned ON). While electricity is supplied, the following steps (from S1107) will be repeated.

In S1107, predetermined information is inputted. If locked (i.e., when a main switch is turned ON), photographing operation is possible. Hence, the process proceeds with the necessary operations. If the lock is released (i.e., when the main switch is turned OFF), the process proceeds to a lock operation at S1181 (SLY09).

When the lock is released for the first time, or if the process is performed for the first time after the photographing lens is mounted, flag F_NEWCOM (a flag which is set up when new communication is performed relative to the photographing lens after completion of old communication) is cleared, and a PZ initializing flag F_PZINIT is cleared so as to perform initialization of power zooming (S1109-S1115, S1121, S1123).

In the case that the lock is not initially released or the process does not perform an operation for the first time after the photographing lens is mounted, but the status is a first AF mode or first PZ mode, flag F_PZINIT is cleared in order to initialize various operations and data relating to AF, PZ, the flag being set when such data are initialized etc. The process then calls a PZINIT subroutine (S1111, S1113, S1117-S1123).

The process inputs switch information and performs an operation (PZLOOP subroutine) relating to power zooming and gives the necessary indication on the display panel. The process then proceeds to S1133 (S1127-S1131).

If the photometric switch SWS is turned OFF during the checking of the photometric switch SWS at S1133, power supply Vdd of E2PROM and the peripheral parts control circuit is partly turned off (S1133, S1135). If flag F_AF, indicating that AF is being performed, is cleared, the process is returned to START, otherwise the process proceeds to step S1165 (S1136).

If flag F_AF is set, it is likely that AF processing and constant image magnification ratio zooming relating thereto have already been performed before photometric switch SWS is turned OFF. Accordingly, a constant image magnification ratio zooming stop flag F_ISZ-STOP is set, and an operation to stop the constant image magnification ratio zooming and to check whether the same has been stopped (IPZENDCHECK subroutine) is performed (S1136, S1165, S1167).

The process then clears focusing flag F_INFOCUS, performs an AF motor stopping operation, sends driving information of AF, etc. to power zooming lens 51 by means of PZ-BSTATE command communication, clears flag F_AF, and proceeds to step S1176 (S1169, S1171, S1173, S1175).

If the photometric switch SWS is turned ON upon the checking operation at step S1133, terminal Vdd is turned ON (constant voltage is supplied), photometry and operations relating to the exposure are performed, and the results are displayed (S1137, S1138). If the status is not AF mode, the process jumps to an operation starting from step S1165 (S1139, S1165).

During the AF mode, flag F_AF is set, a photometric operation or integrating operation is started, and the integrated data is taken into the process so as to perform predetermined predictor operation (S1139, S1140, S1143).

If the results obtained from the predictor operation are effective, the process checks if focusing is required. If focusing is required, a focusing operation or processing is performed (S1145, S1149, S1151). When focusing is not required, and in the case of the non-power zooming mode (F_PZ=0), the process jumps to S1176. In the case of the power zooming mode, the process sends driving information of AF, etc. to the power zooming lens 51 by means of a PZ-BSTATE command, and actuates the AF motor 39. The process then proceeds to the moving object operation or processing starting from step S1159 (S1145, S1149, S1153-S1157).

When the result of calculated predictor is not within an effective range, for example, if the contrast of the object is too low, the process performs a search operation to obtain an effective value, and then proceeds to step S1153 (S1145, S1147). The search operation is to obtain effective defocus amount by means of an integrating operation by driving AF motor 39 in the direction of the closest end or infinite end.

When the focusing operation at step S1157 or AF motor actuation at step S1157 has been completed, and if the object is a moving body, the process performs a moving object follow-up AF operation (S1159). If the status is in the constant image magnification ratio zooming mode, the process performs a constant image magnification ratio zooming operation and then proceeds to release switch SWR check operation at S1176 (S1159-S1163).

At step S1176, the process checks if the release switch SWR has been turned ON. If the release switch is turned OFF, the process is immediately returned to START. If the release switch is turned ON, the process is returned to START after performing a releasing operation, provided that release is permitted (S1176, S1178, S1179).

If the lock is effected (i.e., the main switch is turned OFF) upon checking at S1109, the process proceeds to S1181. If the lock is effected for the first time in this routine and if in the power zooming mode, the process proceeds to a withdrawal operation (S1184-S1209) in order to withdraw the focal length data stored in preset zoom set mode to the camera body. Otherwise, the process jumps step S1223 (S1181, S1183).

If the lock is not effected for the first time, or if the photographing lens is not a power zoom lens, the process shuts OFF the constant voltage supply (CONT) and power supply (VBATT) to the photographing lens, and clears the indication on display 45. The process is then returned to START (S1181, S1183, S1223-S1227).

In the withdrawal operation, the address of the memory (RAM 61b) to be withdrawn is designated by means of a SET-PZPOINT command in order to withdraw the focal length stored in lens RAM 61b to the body. Then, the focal length data stored in the address designated by the FOCALLEN-X command is inputted from lens 51, so as to store them in body RAM 35b at address FLM as focal length data (S1184, S1185, S1187). IMAG-LSIZE data including image magnification ratio is inputted from lens RAM 65b so as to store the image magnification ratio data in body RAM 35b at address ISM, an LENS-INF2 data is inputted from RAM 65b. The process then proceeds to step S1195 (S1181-S1193).

In this embodiment, the image magnification ratio data is transferred to the camera body in order to simplify the process of communication in the retracting operation. However, it may also be possible that both the focal length data, which is obtained when an image magnification ratio is set, and the amount of lens movement data, regarding lens retraction, are transferred.

At steps S1195 and S1197, the process checks whether an accommodation of a power zoom is possible or power zoom is to be effected based on the data input by LENS-INF2. If it is impossible to accommodate a power zoom or power zoom is not to be effected, the process immediately proceeds to CONT1. If power zoom accommodation is possible and power zoom is to be effected (repPZ=1, PZD=1), the body side requests BBATreq to check the battery. When the battery is normal, a command (RETRACT-PZ) to cause power zoom lens 51 to perform a power zoom accommodation operation is sent, a flag F_IPZON to identify that controlled zooming is being performed is set, and an NG timer is started. The process then proceeds to a CONT1 operation (S1195-S1209).

If the battery is found to be abnormal during battery checking, the process proceeds to the CONT1 operation (S1203). It should be noted that flag retPZ relates to information inherent to the lenses. This flag will be cleared when the zooming lens is, for example, an inner zooming lens and hence the lens does not require accommodation or retracting thereof, so that an accommodation or retracting operation is not performed.

In the CONT1 operation, it is checked, based on the AF retraction flag RETAF inputted by the LENS-INF2, whether the power zoom lens 51 is AF-retractable or in an AF mode. If the lens is AF-retractable and in the AF mode, the focusing lens 53F is returned to a retracted position by driving an AF motor 39 (S1211-S1215). Then, if controlled power zooming is being effected, a standby is continued until power zooming has ended, while checking the operation of the controlled power zoom. When power zooming ends, constant voltage supply and power to the camera lens are turned OFF and the display 45 is also turned OFF, resulting in a return to the start (S1217-S1227). If the lens is not AF-retractable or not in the AF mode, the lens retraction operation is skipped. Here, the flag RETAF is information inherent in the lens and is cleared when the zoom lens is an inner focusing type and a retraction of the focusing lens is not necessitated, as a result of which processing for the retraction is performed.

PZ, AF-INIT OPERATION

Hereinafter, the initialization operation of the power zoom lens 51 to be controlled on the side of the body 11

will be described with reference to a PZINIT subroutine shown in FIGS. 56 to 58.

In this operation, the power zoom lens 51 initializes both the zooming lens group 53Z and the focusing lens group 53F and returns the information, sheltered by turning off the main switch in the body, to the lens 51. In detail, the former is an operation which detects the positions of the zooming lens and the AF lens, while the latter is an operation for again returning to the lens 51 (the lens 65b) an image size of ISZ and a focal length for a preset zoom, which are sheltered in the body RAM 35b when the main switch is turned OFF (or locked).

If this processing is initiated for the first time, a new communication flag NEWCOM indicative of the end of the old communication is cleared and thus the old communication is performed to communicate with the lens ROM in synchronization with the clock of the camera body 11. After that, the old communication is switched to the new communication which communicates with the lens CPU 61 in synchronization with the clock of the lens CPU 61 (S1301, S1303).

If an attached camera lens is not a Kz lens (including the power zoom lens 51 according to the present embodiment) having the lens CPU, the new communication is impossible so that the flow is returned. On the contrary, if the lens is the Kz lens, an input of data from the camera lens is effected by the new communication LENS-INF2 (14) and it is checked whether the attached lens is the power zoom lens (PZ lens) (S1305, S1309). If it is not the PZ lens, flag F_PZ, identifying the PZ lens is cleared, and, the flow advances to step S1323 (S1309, S1311).

If the attached lens is the PZ lens, flag F_PZ is set. When a reset is effected in the camera body 11 for when the battery is exchanged) or when the lens is first attached to the camera body 11, an initial value is stored in an image size memory (ISM) (S1313, S1315, S1319). In the other cases, information regarding the focal length for a preset zooming operation and the like, sheltered in the body RAM 35b, is stored through a STORE-PZF (28) communication at a predetermined address (FCL0L, H to FCL7L, H) of the lens RAM 61b for the lens CPU 61. Then, a STORE-IS (29) communication is performed so that the image size, sheltered in the RAM (35b) of the body CPU or the image size of the initial value set at step S1319, is stored at predetermined addresses (ISZ-IMGL, H) of the RAM (61b) for the lens CPU, and a new communication flag is set (S1321, S1323).

Next, the data is inputted through a POFF-STATE (11) communication from the lens CPU 61, and then the flow is sent to step S1361 where a standby operation is performed if flag F_PZINIT, which indicates that initialization of the power zoom has been completed, is set or if the flag F_PZ has been cleared (S1325 to S1329).

If flag PZINIT is cleared and flag F_PZ is set, and when power zooming is not performed (i.e., when flag F_PZD (bit 5 of POFF-STATE data) is cleared), that is, when manual zooming is performed, the flow advances to an AF initialization (AFINIT) operation (S1325 to S1331). When the power zoom mode is used, flag F_BBATREQ, requesting power supply for PZ, is set and the power zoom lens 51 is supplied with power by means of the BATONOFF subroutine. Further, it is checked whether or not the power is supplied thereto in a normal manner (S1131 to S1137). If the power from the battery is not outputted to the power zoom lens 51

in a normal manner thereto (i.e., flag F_BATNG=1), the flow advances to the AFINIT operation. On the contrary, if power supply is normal (the flag F_BATNG=0), a PZ-INITPOS command (32) is outputted to force the camera lens to initialize PZ. Further, the flow advances to the AFINIT operation after setting up the flag F_IPZON, indicating that initialization of PZ has been completed.

AFINIT OPERATION

A flowchart for an AFINIT operation, as shown in FIGS. 57 and 58, is an operation for initialization of the AF. Further, in the present embodiment, the AF is initialized after initialization of PZ. However, the AF may be initialized before initialization of PZ.

In the AFINIT operation, under the condition that the camera lens is in the AF mode, a focusing lens 53F As moved to the retracted position, at which point the tube length is minimized (S1341, S1343). Specifically, the position is the far (i.e., infinity) position according to the present embodiment. The initialization data is then inputted by an AFINITPOS communication and flag F_AFINIT is set (S1345, S1347). Also, upon initialization, the lens CPU 61 generally initializes the lens RAM61b for AF-pulse counting.

Next, if a flag F_IPZON, indicative of power zooming other than manual power zooming being effected, is set, it is checked in an IPZENDCHECK subroutine whether the initialization of power zooming is ended (S1349 to S1353). When the initialization of power zooming has ended, a flag F_PZINIT, identifying the end of power zooming initialization, is set while a battery request flag EF_BBATREQ at the body side is set to "0". Further, in a BATONOFF subroutine, it is requested to stop the power supply and it is checked if the stop has been completed (S1355 to S1359).

Then, if the power supply for a photometric IC17, CCD21 and E²PROM43 and the like of the body 11 are turned ON (Vdd ON), the flow is returned. However, if they are turned OFF, a STANDBY command is effected, and the flow is returned after the lens CPU 61 of the camera lens 51 is set in a standby state (a transfer to a low power consumption mode) (S1361, S1363).

BATONOFF OPERATION

A BATONOFF flowchart, shown in FIG. 59, illustrates a checking operation performed by a main CPU 35, wherein it is determined whether power for a zoom motor 65 is normally supplied from the camera body 11 to the power zoom lens 51 upon issuance of a power request (or a battery request) from the body or the lens. In the present embodiment, such a battery request may be issued by either of the camera body 11 itself or the camera lens 51.

In the BATONOFF operation, first of all, if the battery request is not issued from either of the power zoom lens 51 or the camera body 11, the flow is returned when power supply to the VBATT terminal has been already stopped (i.e., when flag F_BATON has been cleared (S1401, S1403, S1405)). However, when the power supply is effected the power supply to the power zoom lens 51 is turned OFF, the flag F_BATON is cleared, a BODY-STATE0 output command issued so as to send information indicative of the power supply being turned OFF (BATT of bit 5 is cleared) to the lens. Thereafter the flow is returned (S1421 to S1425).

When the battery request is issued from the power zoom lens 51 or the camera body 11 (i.e., when a LBA-

TRE0 or BBATREQ of bit 1 of the POFF-STATE data is set) and if the power is not yet being supplied, the power zoom lens 51 starts to be supplied with power and BODY- STATE0 data, concerning the body state, transmits information indicative of the power supply being supplied (i.e., a BBAT of bit 5 is set) to the lens. After the flag F_BATON, identifying the power supply underway, is set, POFF-STATE data is inputted. However, if the power supply is already turned ON, the flow goes directly to step S1415 where POFF-STATE data is inputted (S1407 to S1415).

If the battery supply is normal (i.e., flag F_BDET = 1 in bit0 of POFF-STATE), the flow is returned (S1417). However, if the battery supply is abnormal, for example, in the case of a short circuit, flag F_BATNG identifying the battery abnormality is set, power supply to the power zoom lens 51 is cutoff, and flag F_BATON is cleared. Further, a BODY-STATE0 command is issued to send to the lens information regarding the "ON" state of the power supply and then the flow is returned (S1419 to S1425).

PZ-LOOP OPERATION

A PZ-LOOP operation, as shown in FIGS. 60A, 60B and 61, is an operation of power zooming which is intermittently performed by the main CPU 35. In this operation, a plurality of tasks, such as power zoom relations, preset zooming, by which power zooming is adjusted to a preset focal length, and presetting of the focal length and image size constant zoom control are processed. In the present embodiment, the current focal length is stored when an SL switch is turned ON (a PZ mode switch 77) during a preset zoom set (PSZS) mode while power zooming is adjusted to the preset length when the SL switch is turned ON during a preset zoom (PSZ) mode. Then, an image size, at the time when the SL switch is turned OFF, or when a zoom operation ring is returned to the neutral position (i.e., when a PZ speed switch 75 is turned off), is stored.

Upon initiation of this operation, the flow advances to S1505 at which point the respective tasks are processed under the condition that the new communication and power zooming are enabled, but the flow is directly returned if the new communication is impossible. Also, when the new communication is possible, but power zooming is impossible, a BODY-STATE0 communication is effected (S1501, S1503, S1504-1). With this BODY-STATE0 communication, the body-side information, such as a mode information of the power zoom, is sent to the lens, but an input of the information of the lens, such as the state of the switch of the lens, is performed by the POFF-STATE communication when the Vdd is turned on (S1504-2, S1504-3). When the Vdd is turned OFF, an input of the lens information is performed by the POFPS-WSLEEP communication and the lens CPU 61 is transferred to the standby mode (the low power consumption mode) (S1504-2, S1504-4). Due to the POFPS-WSLEEP command, the lens CPU 61 maintains low power consumption until the next communication command is received.

At S1505, various data, such as lens switches from the power zoom lens 51, are inputted in the POFF-STATE. Further, depending on the data, a switching of the PZ mode and a display correction are effected and the power supply is performed or stopped (S1503 to S1509). Then, based on the inputted data, the following operations are performed (S1509 to S1511).

If the current mode is the preset zoom (PSZ) mode, the actuation of constant image size zooming is inhibited (flag F_ISZSTOP is set) and constant image size zooming is completed in an IPZENDCHECK subroutine (S1513 to S1517). Unless a preset zooming actuation (or drive) is initiated (the SL switch is turned ON), the flow is returned (S1519). If the preset zooming actuation is initiated and continues (F_IPZON=1), a checking operation which determines if the preset zoom has ended is performed in the IPZENDCHECK subroutine. When it has ended, the flow is returned (S1519, S1521, S1555).

Unless preset zooming is being actuated, the camera body 11 itself requests the power supply, and the power supply is performed (S1521 to S1525). Then, if the battery is abnormal, the flow is directly returned. On the other hand, if the battery is normal, power zooming is adjusted to a focal length position which is stored at an address designated by a transmission of a MOVE-PZND command, and the flow is returned followed by setting of a flag F_IPZON, which identifies the continuation of preset zooming (S1527 to S1531).

If the current mode is the preset zoom set (PSZS) mode, a flag (F_ISZSTOP, F_IPZSTOP) by which preset zooming and constant image size zooming drive are stopped, is set and in the IPZENDCHECK subroutine, preset zooming or the constant image size zooming drive is stopped (S1513, S1541, S1543, S1545).

Then, when the SL switch is turned ON, in order to store the current focal length in a designated address of the lens RAM 61b by the lens CPU 61, a STORE-PZP command is transmitted to the power zoom lens 51, the preset zoom set (PSZS) mode is changed to the preset zoom (PSZ) mode, whereas the values of bit 2-0 in the BODY-STATE0 command are changed, and the power zoom lens 51 is notified of changes, such as a renewal of the preset zoom mode by an output of the BODY-STATE0 data. Thereafter the flow is returned (S1547 to S1553). If the SL switch SW remains OFF, the flow is returned without any processing (S1547).

When the current mode is the constant image size zooming mode, preset zooming is stopped and it is checked if a preset zooming has ended (S1541, S1561, S1563, S1565).

Here, when the SL switch is being depressed, a flag F_PZWAIT, which inhibits initiation of constant image size zooming, is set and the flow is returned (S1567, S1577). When the SL switch is turned OFF, LENS-INF1 data is inputted. If the zoom switch (a zoom speed change switch 75) is turned ON, a flag F_PZWAIT, which inhibits an initiation of a constant image size zooming, is set and the flow is returned (S1567, S1577). If the zoom speed change switch 75 is positioned at a neutral point (i.e., when it is turned OFF), flag F_PZWAIT is cleared and the focus condition is checked. If it is out-of-focus, the flow is returned (S1571 to S1575). If it is in-focus, an ISZ-MEMORY command for storing an image size, at the time when the SL switch is turned OFF or when the zoom speed change switch 75 is returned to the neutral point (turned off), is outputted to the camera lens, and the flow is returned. If none of the above are applicable, the flow is directly returned (S1579 to S1583).

If none of the above modes are applicable, preset zooming and constant image size zooming are stopped and the flow is returned after checking the end of preset zooming (S1513, S1541, S1561, S1585 to S1587).

IPZENDCHEK OPERATION

An IPZENDCHEK flowchart, shown in FIG. 62, is a body-side operation which finishes preset power zooming and constant image size zooming and checks for the completion thereof.

Upon initiation of the IPZENDCHEK subroutine, during a constant image size zooming completion and constant image size zooming-on (F_ISZSTOP=1, F_ISZON=1) or during a preset zooming completion and the preset zooming-on (F_IPZSTOP=1, F_IPZON=1) state, an NGTIMER flag and an IPZEND flag are cleared, a transmission of an IPZ-STOP command to stop the power zoom is performed to clear the respective flags F_ISZON, F_IPZON and BBA-TREQ, and the flow is returned after stopping the battery supply and checking it (S1601 to S1607, S1623 to S1631).

If it is not currently in the constant image size zooming-on or preset zooming-on, state a PZ-LSTATE data inputted and it is determined whether the power zoom lens 51 is in the preset zooming-on or constant image size zooming-on states. If it is not currently in the zooming-on (IPZB=0), state a preset zooming completion flag or constant image size zooming completion is set and the flow is returned (S1601 to S1617). If currently in the preset zooming-on or constant image size zooming-on (IPZB=1) states, the flow is returned unless an abnormal detection timer (NG timer) expires (S1619).

Since it is expected that an abnormal event has occurred if the NG (abnormality detection) timer expires before the end of constant image size zooming, a TIMEUP flag is set (F_TIMEUP=1) and a NGTIMER flag and IPZEND flag are cleared (F_NGTIMERUP=0, F_IPZEND=0) (S1622-1, S1622-2). Then, a power zooming stop operation is performed (S1623 to S1631). If the NG timer has not yet expired, the flow is directly returned.

ISZ-DRIVE1 OPERATION

A flowchart (ISZ-DRIVE1) as shown in FIGS. 63 to 66 is an operation in body CPU 31 in which the power zoom lens 51 (a lens CPU 61) is forced to perform a constant image size zooming operation. The ISZ-DRIVE operation is called at S1163, as shown in FIG. 53.

When the focusing lens is at its infinite position, data concerning an AF position is transmitted to the power zoom lens 51 by an AF-INTPOS command (S1701, S1703). When the focusing lens is at its near position, PZ body state data concerning the power zoom mode of the camera body is transmitted to the power zoom lens 51 by PZ-BSTATE (S1701, S1705, S1707).

If a power zoom wait (F_PZWAIT=1) has been effected or if the result of a predictor operation is invalid, the flow is returned without any processing (S1709, S1711). If power zoom wait has not been effected and the result of the predictor operation is valid, the focus condition is checked (S1709 to S1713). If it is in-focus, it is determined whether the NG timer has been actuated (F_NGTIMER=1). If it has not been actuated, the NG timer is started and a flag F_NG-TIMER is set, thereafter advancing to step S1721 (S1713, S1715, S1719, S1720). If the NG timer has already been actuated, the foregoing operation is skipped and the flow is advanced to S1721.

Next, after checking the completion of constant image size zooming at step S1721 (IPZEND-CHECK),

it is determined whether the completion of the same has occurred while in the constant image size zooming-on state (S1723, S1725). If in the constant image size zooming-on state (F_ISZON=1) and the constant image size zooming has ended (IPZEND=1), flag IPZEND is cleared and flag ISZSTOP is set. Further, the flow is returned after an end operation of constant image size zooming is performed in an IPZEND-CHECK subroutine (S1725 to S1729).

If it is not in the constant image size constant zooming-on state or if the constant image size zooming has not ended, a transmission of data concerning the power zoom state in the camera body 11 is performed by a PZ-BSTATE command (S1723, S1725, S1731). Then, if it is not in the constant image size zooming-on state, the power supply is requested ON by the body side and that of the battery supply is performed. Further, after a flag identifying the continuation of constant image size zooming is set, the flow advances to an in-focus judgment but the flow advances to the in-focus judgment. However, if it is already in the constant image size zooming-on state (S1733 to S1741), the flow directly advances to the in-focus judgment.

If it is in-focus, in order to perform constant image size zooming based on the current AF pulse (i.e., the value of AFPXL, AFPXH), predetermined data is transmitted to the power zoom lens 51 by the BODY-STATE 1 command. Further, after a transmission of a constant image size zooming start (ISZ-START) command is effected to start constant image size zooming by the power zoom lens 51, the flow is returned (S1741 to S1745). If it is out-of-focus, defocus pulse data, measured by the camera body 11, is transmitted by a STORE-DEEP and D command. After that, data, by which the constant image size zooming is effected based on the defocus pulse, is transmitted by a BODY-STATE1 command. Finally, a constant image size start command (ISZ-START) is transmitted, and the flow is returned.

ISZ-DRIVE2

Hereinafter, a second embodiment of the constant image size zooming operation shown in FIGS. 65 and 66 will be described. This second embodiment is characterized in that the operations and controls concerning a constant image size zooming are performed in the camera body 11.

Since the operations from S1801 to S1823 are similar to those from S1701 to S1731, explanations are omitted. Hereinafter the operations from S1825 will be described.

If the lens is not focused, transmission of data concerning the power zoom state of the camera body 11 is performed by a PZ-BSTATE command (S1813, S1825 to S1833). Then, if the power zoom lens 51 is not undergoing a constant image size zooming, the power supply is requested by the body side. The battery supply operation and the checking thereof are then performed. Additionally, a control zooming-on flag F_IPZON is set (S1827 to S1833).

Next, a transmission of a SET-PZPOINT command is issued designating an address of the lens RAM 61b in which the focal length, at the time of image size storing, is stored, and an input of the focal length (FOCALL-EN-X data), at the time of image size storing and designated by the SET-PZPOINT command, is issued from the power zoom lens 51 (S1835, S1837). Further, a transmission of a SET-AFPOINT command is effected

with a designation of the focal length data, at the image size storing, stored in the lens RAM 61b, and an input of number of AF pulses (LENS-AFPULSE data), at the time of the image size storing, is effected from the lens 51 (S1839, S1841). Then, the image size (x0f0) is operated based on the inputted data (S1843). Further, a transmission of the SET-AFPOINT command is effected with a designation of the current number of the AF pulses and an input of the current number of the AF pulses, (LENS-AFPULSE data) is effected based on the designation from the lens 51 (S1845, S1847).

Next, it is whether if the lens is in-focus and, in the case that it is in-focus, the focal length is found from equation (4) by utilizing the current number x of AF pulses. If it is not in-focus, it is determined if the photographing image is a moving object. If it is a moving object, the focal length is calculated in the same manner as that of the in-focus calculation, based on the present AF pulse. If it is not a moving object, a target focal length is found from equation (5) utilizing the current number x of AF pulses and de-focus pulses Δx (S1849 to S1853). Then, after transmissions of a command by which the power zoom is performed to the operated target focal length and the focal length data (MOVE-PZF command), the flow is returned (S1855).

The lens CPU 61, receiving this MOVE-PZF command, drives a zooming lens 53F to the target focal length sent from the camera body.

In this embodiment, the method for calculating the target focal length is changed according to the focusing state of the photographing lens. However, the method may be changed according to other conditions, for instance, the condition of whether or not the moving object prediction mode is being effected.

In this case, a judgement operation "Is the photographing image a moving object?" is to be added before S1853. In the case of a moving object, the target focal length is calculated by the present lens moving amount at S1851. If it is not a moving object, the focal length is calculated at S1853. The reason why the target focal length is calculated without utilizing defocus amount when the moving object prediction mode is effective, is to make the driving speed of the lens faster and more stable.

ISZ-DRIVE3

A constant image size zooming operation, shown in FIGS. 67 and 68, illustrates a third embodiment of the present invention. In this embodiment, a modification the constant image size zooming is controlled at the side of the body 11. In detail, in the case that the constant image size zooming is effected after the lens comes into focus once, the in-focus state may be shifted when the zooming is ended. Therefore, according to the third embodiment, the AF operation and constant image size zooming are again effected after the constant image size zooming has ended. In addition, this embodiment is provided with a method for driving the lens during constant image size zooming by changing its speed depending on the speed of moving object at the time of the moving object prediction AF.

If the focusing lens 53F is in the far position, an AF-INITPOS command is transmitted to the taking lens (power zoom lens 51 (S1901, S1905, S1907)). If the focusing lens is in the near position, PZ body state data concerning the power zoom mode of the camera body is transmitted to the power zoom lens 51 by PZ-BSTATE command (S1901, S1905, S1907).

If the lens is in a power zoom wait mode or if the result of the predictor operation is invalid, the flow returns without any processing (S1909, S1911).

If the lens is not in the power zoom wait mode and if the result of the predictor operation is valid, it is checked whether a subject is a moving object (S1909 to S1913). If the subject is a moving object and the constant image size zooming-on flag has been cleared (i.e., not during constant image size zooming), a body's battery request flag (F_BBATREQ=1) is set and battery supply is effected. Further, the constant image size zooming-on flag (F_ISZON=1) is set (S1961 to S1967). Then, power zoom speed is set, depending on the speed of the moving object (moving speed on an image surface). Flag ISD is cleared to effect the ISZ control by using the set power zoom speed data and the AF pulse at the current position. Further, a transmission of an ISZ-START command is effected through the BODY-STATE1 data communication to force the camera lens 51 to commence constant image size zooming (S1969 to S1973).

In the case that the object is not moving, it is checked if the lens is in-focus for the second time (F_IN-FOCUS=2) or the first time (F_INFOCUS=1 (S1913, S1915, S1917)). Here, the F_INFOCUS is two bits. If the lens is not in-focus for a first or second time, i.e., in an initial state, it is checked if it is in-focus. If it is not in-focus, the flow is returned. In the case of an in-focus condition, body battery request flag BBATREQ is set to effect the power supply, and the constant image :size zooming-on flag F_ISZON is set (S1919 to S1925).

Then, the transmission of the constant image size zooming start command is effected so that the constant image size zooming and the NG timer are started. It is then determined whether the constant image size zooming has ended. When it has ended, the first operation is ended after a first in-focus condition flag is set and a constant image size zooming end flag F_IPZEND is cleared (S1935 to S1940).

The next time this operation is initiated, the flow moves from S1917 to S1941 because the first in-focus flag is set. It is then rechecked whether it is again in-focus. If it is not in-focus, the flow is returned and the foregoing operation is repeated until an in-focus condition is achieved. If it is in-focus, the NG timer is started and the constant image size zooming start command is transmitted to the camera lens to force the camera lens to start the constant image size zooming. The flow is then returned after the second in-focus flag is set (S1943 to S1947).

If the ISZ-DRIVE 3 operation is initiated after the end of the S1947 operation, the second in-focus flag is set so that the flow advances from S1915 to S1951 and it is checked if the constant image size (control) zooming has ended. If the control zoom has not ended, the flow is returned. If the control zoom has ended, a control zoom end flag IPZEND is cleared and a constant image size zooming stop flag ISZSTOP is set. The flow is then returned after the constant image size zooming end operation is performed (S1953 to S1957).

AFP-CNT OPERATION

An AFP-CNT operation, shown in FIG. 69, is an AF pulse count operation in the power zoom lens 51 o The lens CPU 61 comprises an AF pulse counter for counting AF pulses outputted from an AF pulser 59 in a hardware manner. This AFP-CNT operation is initiated at 2 ms intervals by a 2 ms timer interrupt. This opera-

tion illustrates, in detail, the operation at S303 in the 2 ms timer interrupt routine, as shown in FIG. 9.

In the AFP-CNT operation, a count value of the AF pulse hard counter is first stored in an AF pulse count value memory (addresses AFPCNTL, H of the lens RAM 61b (S2001)). Then, by reference to data (i.e., data installed in bit 3-0 of PZ-BDST, which is a predetermined address of RAM 61b) concerning an AF operation which is inputted by PZ-BSTATE command when an AF motor 39 is moving the lens to the near end and before it arrives at the near end, the AF pulse count value is added to an AF pulse count start value (AFPSTRTL, H). This is stored in the current AF pulse value memory (AFPXL, H of the lens RAM 61b) before ending the routine. However, if it arrives at the near end, the flow immediately ends (S2002 to S2007).

When the AF motor 39 is moving the lens to the far end and before it arrives at the far end, the AF pulse count value is subtracted from the current AF pulse count start value and the result is stored in the current AF pulse value memory (AFPXL, H) to end the AFP-CNT operation. If it arrives at the far end, the AFP-CNT operation is immediately ended (S2009 to S2013). Also, if the lens is neither moving towards the near end nor the far end, the AF motor does not rotate. Therefore the AFP-CNT operation ends without any processing (S2002, S2009).

AFP-ADJ OPERATION

An AFP-ADJ flowchart, shown in FIG. 70, is an operation at the side of the camera lens 51. It amends the current AF pulse value affected by backlash and the like. In the present embodiment, the AF pulse value at the far end is set at zero and the AF pulse value at the near end is set at the maximum value. Then, the present AF pulse count is amended every time the brush 85 crosses one of the indicators 83 on the distance code 81, in accordance with an absolute pulse number, which is to be determined by the position of the indicator 83, based on an absolute value code. The present operation is a detail of the 2 ms timer interrupt routine at S307, as shown in FIG. 9.

Upon initiation of the AFP-ADJ operation, it is first checked if the brush 85 has contacted the indicator 83. If not, the operation is ended (S2021). If it is contacted, the flow is directly returned in the case that such a contact was achieved during the preceding operation (S2021, S2023). In other words, the time when the indicator 83 and the brush 85 contact is detected (at an edge of the indicator 83).

If the indicator 83 and the brush 85 contact each other and such contact occurs when the AF motor 39 is moving the lens to the far position, an AF pulse FAR table data (data concerning an edge at the near end side of the indicator 83) corresponding to the near end position of the indicator 83 is read and stored in addresses AFPCDL, H. If such contact occurs during the near end movement, an AF pulse NEAR table data (data concerning an edge at the FAR end side of the indicator 83) corresponding to the far end position of the indicator 83 is read and stored in addresses AFPCDL, H (S2025 to S2033). The reason why there are two kinds of tables, i.e. the FAR table and the NEAR table is because the indicator 83 has a width and an absolute position at the contact time which is different along the width, depending on the contact direction. When the AF motor 39 is stopped, the flow is immediately ended

(S2027, S2031). Further, a flag F_AFPADJ at S2025 is provided for test purposes and is usually cleared.

Next, if the current AF pulse value is known (when flag F_AFPOS is set), the current AF pulse count value (data of the AFPXL, H) is subtracted from the table data (AFPCDL, H) and its subtracted value (difference) is stored in an AF pulse error memory (AFP-DIFXL, H (S2035, S2037)). Here, when the error is negative, the absolute value of the error is stored in an AF pulse current value memory (S2039, S2041).

It is then checked whether the difference is larger than an allowable error (N_AFPDIF). If it is smaller, the operation is directly ended. However, if it is larger, an amendment is effected; that is, the table data (AFPCDL, H) are incorporated into the current AF pulse value memory (AFPXL, H) and the AF pulse count start value memory (AFPSTARTL, H (S2043, S2045)). On the other hand, if the AF pulse current value is not known, the amendment operation at S2045 is unconditionally performed (S2035, S2045).

Then, the AF pulse hard counter is cleared and started and the AF pulse count start value (AFPCNTL, H) is cleared. After that, flag F_AFPOS, showing the current AF pulse value being known, is set and the operation ends (S2047, S2049).

LMT-DTC OPERATION

A LMT-DTC flowchart, shown in FIG. 71, is an operation on the side of the camera lens 51. This operation detects that a zooming lens group 53Z has arrived at an end point, or that movement is prevented by some external circumstances (i.e., the lens group 53Z has arrived at a para-end point). According to the present embodiment, such detections are performed by checking if, during the driving of a PZ motor 65, the PZ pulses are outputted within a predetermined period of time. Further, the predetermined period of time is changed depending on a driving speed of the PZ motor (zooming speed). Also, since a starting torque becomes larger for a constant period after the start of the PZ motor (i.e., upon a transfer from a stop state or a braking state to a driving state), the detection of the end point is not performed. The present operation illustrates the detail of the 2 ms timer interrupt routine at S351, as shown in FIG. 10.

First, it is determined whether the PZ motor is performing a driving operation. In the case of non-driving, the flow exits after clearance of a limit counter T_LMT, which detects the arrival at a limit (i.e., the end point or the para-end point (S2061, S2071)). Specifically, a PWM timer T_PWM is cleared when the PZ pulse is outputted to initiate the PZ pulse count interrupt operation, as shown in FIG. 12.

During the PZ drive, it is determined whether a counter T_START, which measures the time since the start, becomes zero (i.e., whether a predetermined period of time has expired). In the case that it is not zero, the counter T_START is decremented by one and the limit counter T_LMT is cleared to leave the operation (S2061, S2063, S2069, S2071). This processing is initiated every 2 ms so that the counter T_START is decremented every 2 ms. The value of the counter T_START is set at a predetermined value when the zoom motor is started, but the end point detection is not performed within a constant period after that start.

The fact that the counter T_START becomes zero means that a predetermined time has expired after the

motor start. As a result, the flow advances to the operation of end point detections, from S2065.

In the case where a duty ratio T_PWMBRK of a PWM becomes more than its maximum limit value N_PWMMAX, counter T_LMT for the end point detection is incremented by m one and the flow advances to S2073. In the opposite case, the flow exits and advances to S2073 (S2065, S2067). Also, if the motor is engaged in DC drive (i.e., the maximum speed drive), the value of the maximum limit value N_PWMMAX, as a duty ratio T_PWMBRK, is established. Therefore, during the DC drive, the limit counter T_LMT is incremented by one (S2065, S2067).

Next, a PWM drive of the zoom motor is controlled as follows:

The PWM duty ratio T_PWMBRK is usually set at a smaller value than the maximum limit value N_PWMMAX. Accordingly, counter T_LMT is not incremented and the flow exits (S2065, S2073). However, if the PZ pulse is not outputted for a constant period of time, the duty ratio T_PWMBRK is gradually increased by the 2 ms timer routine and becomes a value similar to the maximum limit value N_PWMMAX (generally DC drive) after a predetermined period to let counter T_LMT be incremented by one.

Here, in the case of the PWM low speed drive, the value of the PWM duty ratio T_PWMBRK is small in the beginning. Therefore, upon arrival at the end point or the para-end point, it takes a long time for counter T_LMT to be incremented.

In the case of the PWM high speed drive < the value of the PWM duty ratio T_PWMBRK is large. Therefore, upon arrival at the end point or the para-end point, it takes a shorter time for the counter T_LMT to be incremented in comparison with that of the PWM low speed drive.

With the above processing, it is possible to change the end point detection time depending on the zoom motor drive speed (S2063, S2067). Further, if the counter T_LMT is below a predetermined value (N_LMT), a predetermined end point detection period will have not yet expired so that the flow immediately leaves this subroutine (S2073).

If the counter T_LMT increases beyond the predetermined value N_LMT, it is regarded as the end point or the para-end point. In the case of a tele-direction o drive, a tele end flag F_TEND is set if a zoom code is a tele end value. However, if the zoom code is not the tele end value, its stop is effected by any abnormality and therefore a para-tele end flag F_LMT is set (S2075 to S2081). In the case of a wide-direction drive, a wide end flag F_WEND is set if a wide code is the wide end value. However, if the zoom code is not a wide end value, its stop is effected by any abnormality. Therefore, a para-wide end flag F_LMTW is set (S2075, S2083 to S2087).

SET-ST OPERATION

A SET-ST flowchart as shown in FIGS. 72 to 80 is an operation at the side of the power zoom lens 51 and configured to settle a status (speed control bit) such as controls of rotational direction, speed, stop and brake of the zoom motor. The present operation is a detail of the 2 ms interrupt routine, as shown in FIG. 10. Further, this SET-ST operation includes, as shown in FIGS. 72 to 80, a MOV operation, an INIT3 interrupt operation, a NO-MOVE, a MOV1 operation, BRK1, 2-operation,

a STP1 operation, a MOV-TRG operation and a DRV-TRG8 operation.

Firstly, a power request flag F_BATREQ is set and position of the zoom speed change switch 75 is transformed into a predetermined code (which indicates its direction and speed). Thereafter the code is stored in a transformed value memory TRNSSPD (S2101, S2103).

If the lens is driven towards a designated position (F_MOVTARG=1), the flow advances to the MOV-TRG operation. If it is an usual move or drive in a designated direction (i.e., when a F_MOV is set), the flow advances to the MOV operation (S2105, S2107).

If it does not correspond to any move or drive and a zoom operation ring is located on a neutral position (when the zoom switch 75 is turned OFF), the flow advances to the MOV-TARG operation when in the image size constant zoom mode while the flow advances to the NO-MOV operation when in the non-image size constant zoom mode (S2109, S2115). If the zoom operation ring is not located in the neutral position, the flow advances to the NO-MOV operation when a manual power zoom stop bit is set (F_MPZD=1). If not, manual power zooming is being effected, and therefore, the flow advances to the MOV operation with a storage of a zoom speed data, which is transformed from a zoom switch status, in an address SPDDRC1 (S2109, S2111, S2113).

In the above operation, since upon initiation of a release operation in the body and the like, a flag F_MPZD is set by a communication command BODY-ATATE1 (22), the manual power zoom operation during the release can be stopped. Also, upon reception of a transmission of a communication command IPZ-STOP (35) for stopping the power zoom, the respective flags such as F_MOVTRG, F_MOV and F_ISZ are cleared. Therefore power zoom operations in addition to the manual power zoom can be stopped.

MOV OPERATION

Next, control of the power zoom motor will be described with reference to a MOV flowchart, as shown in FIGS. 73 to 75. This control is an operation in the body power lens 51 and concerns manual zooming and controlled power zooming in a designated direction (i.e., when the flag F_MOV is set up).

Firstly, it is checked (i.e., bit0 of a move direction memory SPDDRC1) if movement is in the tele direction (F_TELE1=1 (S2201)).

If the direction of movement is in the tele direction and it arrives at the tele end or para-tele end, the flow advances to the NO-MOV operation (S2201 to S2205). If it is an initial movement (or a start), the flow advances to an operation S2233 for initialization (S2207). Then, by reference to data concerning the previous zooming motor operation stored in the memory ZM-ST1, which is used for operating the zoom motor, if movement occurred the preceding time, but in a different direction (of the zoom motor), or if the power supply from the body is turned off, the flow advances to the brake operation (BRK1 [S2207 to S2211]). If, at the present time, the movement is in the same direction as that of the preceding operation and the power supply is turned ON, the flow advances to a speed settle operation at S2249 (S2207 to S2211).

If the movement is not in the tele direction, but arrives at the wide end or the para-wide end (F_WEND=1 or F_LMTW=1), the flow advances to the NO-MOV operation (S2201, S2223, S2225). If the lens

starts, but does not arrive at the wide end or the para-wide end, the flow advances to a processing S2233 for initialization. If movement occurred the preceding time, but the present movement is in a different direction or if the power supply from the body is turned OFF, the flow advances to the brake operation (BRK1). If the present movement is in the same direction as that at the preceding movement and if the power supply is turned ON, the flow advances to the speed settle operation at S2249 (S2225 to S2231).

The initial set up operation upon start-up is executed on condition that power from a power source is being supplied. If power is not being supplied, the operation proceeds to an ending process (NO-MOV1 [S2233 represents the foregoing operation]).

When power is being supplied, the brake counter T_BRK is incremented by 1, if the brake flag F_BRK is set (i.e., when the motor is being braked). If the brake counter T_BRK is less than a predetermined value (N_BRKREV), the operation proceeds to a brake 2 operation (BRK2) at which point a brake is applied (S2235 through S2239).

When the brake flag F_BRK has been cleared, or if it has been set while the brake timer T_BRK is greater than a predetermined value, braking is completed. In such a case, the start up flag F_START is set, and the limit timer T_LMT and the PWM timer, T_PWM, are cleared. Then, a counter is set so that a terminal detection does not take place for a certain period of time after the start-up, and the initial value (i.e., minimum value) of the PWM duty ratio is set (S2235 through S2241 represent the foregoing operational). This means that the start flag F_START is set, terminal detecting counter T_LMT and PWM counter T_PWM are cleared, an initial value is entered at the start counter T_START, and a duty ratio T_PWMBRK of PWM is filled with the minimum value. Setting the minimum value at T_PWMBRK provides the slowest start-up for PWM.

Upon completion of the setting operation, the LED of the PZ pulser 69 is turned ON to prepare for the PZ pulse count. Then, the PZ pulse count interruption (INT3) is enabled, if it was disabled, before proceeding to a speed setting operation [S2249 (S2243 through S2247 represent the foregoing operations)].

In the speed setting operation, a PZ pulse interval (T_PWMPLS value) is set according to the speed selected. In this preferred embodiment, the time during which electricity is supplied at PWM is controlled so that PZ pulses are outputted at the selected PZ pulse interval. Four speeds can be selected in this preferred embodiment, but not limited to four. The speed is selected according to the two bits, bits 2 and 3 (F_SPDA1, F_SPDB1), of SPDDRC1. Since the fourth speed is not controlled by the PWM control, but rather by the DC control, a PZ pulse interval is not set. The Maximum value is set at PWM duty ratio T_PWMBRK for terminal detection (S2065 in FIG. 71).

Upon completion of the speed selection, the speed and its direction (SPDDRC1) are inputted in the zoom control memory (ZM-ST1), drive flag F_DRV is set, and brake flag F_BRK is cleared (S2251). Bit 3-0 of ZM-ST1 (i.e., flags SPD1, SPD0, DRCW, DRCT) are set so that the flags correspond to bit 3-0 of SPDDRC1 (i.e., flags SPDB1, SPDA1, WIDE1, TELE1), respectively. The telephoto end and wide-angle end dummy flags, F_LMTT and LMTW, are then cleared. The

drive direction flags, F_TMOV, F_WMOV, F_TELE1, F_WIDE1, are set while the telephoto end and wide-angle end flags, F_TEND and F_WEND, are cleared (S2253 through S2257 represent the foregoing operations). F_TMOV, F_WMOV, F_TEND and F_WEND are flags for the PZ-LST data, and are set so that flags F_TMOV and F_WMOV correspond to F_TELE1, F_WID1 of SPDDRC1, respectively. In the case that either one of F_TMOV and F_WMOV is set, the other is cleared.

During the zooming operation at a constant image magnification, manual power zooming is activated by interrupting the constant image magnification. Predetermined bits are set at the memory data (PZ_LST) for the PZ conditions of the lens, and the flag is set before processing is completed (S2259 and S2267). When zooming is not being performed at a constant image magnification, if power zooming (manual power zooming) is being effected by a zoom switch operation, data including flag F_MPZ for manual power zooming is set at the zoom condition data (PZ-LST). If controlled power zooming (i.e., zooming to a specified direction) is being effected, data (including flag F_IPZB) for the controlled power zooming are entered at the zooming condition data (PZ-LST), before the SET-ST operation is completed (S2261 through S2265 represent the foregoing processes). The content of the PZ_LST data is transmitted to the camera body by means of communication using command PZ-LSTATE(10).

INIT3 INTERRUPTION ENABLING OPERATION

FIG. 76 shows an operation that enables interruptions by the PZ pulse count. In this preferred embodiment, the PZ pulse counting is effected by software using an interruption of a 2-ms timer. In this process, the enabling bit for the INIT interruption is set to enable counter interruptions by PZ pulses. This operation shows the details of step S2247 in FIG. 74 and S2457 in FIG. 82.

NO-MOV AND NO-MOV1 OPERATIONS

Flow charts NO-MOV and MOV1 shown in FIG. 77 are operations that stop the power zooming operation or effect a shift to a braking operation. When power zooming is being effected (i.e., when flag F_DRV has been set), the operation proceeds to the BRK1 operation. If power zooming is not being effected, and if the brake is not being effected (i.e., flag F_BRK has been cleared), the operation proceeds to the ending operation (STP1). If the brake is being effected, the brake counter is incremented by 1, and if the value exceeds a predetermined value (N_BRK), the ending operation (STP1) is executed. If the value is less than the predetermined value, the operation proceeds to Brake 2 (BRK2) to continue the braking operation (S2301 through S2307 represent the foregoing processes). Since this NO-MOV1 operation is performed when power zooming is not being effected, the ocess begins from step S2303, skipping step S2301.

FBRK1 AND BRK2 OPERATIONS

In the brake operation (BRK1) in FIG. 78, brake timer T_BRK is cleared and the telephoto direction flag F_DRCT, wide-angle direction flag F_DRCW, speed-1 flag F_SPD0, speed-2 flag F_SPD1, and drive flag F_DRV are cleared. Brake flag F_BRK is then set (S2311 and S2313 represent the foregoing processes).

Since BRK2 is entered only after the second operation, only step S2313 is executed. After completing the above operations, the SET-ST operation is completed.

STP1 OPERATION

The STP1 flow chart shown in FIG. 79 is an operation for stopping the power zooming operation.

First, the PZ pulse count interruption is disabled, and the LED of the PZ pulser 69 is turned off (S2321 and S2323).

When the zoom switch 75 is at the neutral position, ZM-ST1 data is cleared (i.e., all the flags are cleared), and a battery request is cancelled (S2327, S2337 and S2347) before proceeding to step S2349. When the zoom switch 75 returns to the neutral position, the dummy terminal flags (F_LMTT and F_LMTW) are cleared. Therefore, zooming can also be performed in the direction that the dummy terminal was previously set.

When the zoom switch 75 is not set at the neutral position, but rather the telephoto direction, flags F_LMTT and F_LMTW in the ZM-ST1 data are left unchanged, while all the other flags are cleared (S2329, S2331). If the lens is at the telephoto end, or at the pseudo-telephoto end a battery request is cancelled before proceeding to S2349. If the lens is neither at the telephoto end nor the pseudo-telephoto end, the battery request is not cancelled, and the operation proceeds to step S2349 (S2333 and S2335 represent the foregoing processes). When the zoom motor 65 is revolving toward the wide-angle direction, flags F_LMTT and F_LMTW in the ZM-ST1 data are left unchanged, while other flags are cleared (S2329 and S2341). In the wide-angle end or in the pseudo-wide-angle end, the battery request is cancelled before proceeding to step S2349. If, however, the lens is neither at the telephoto end nor the pseudo-telephoto end, the battery request is not cancelled before proceeding to step S2349 (S2343 and S2345 represent the foregoing processes).

In S2349, whether zooming with a constant image magnification is being effected is tested. In step S2351, whether a calculation for zooming with a constant image magnification has been completed is tested. If zooming with a constant image magnification is in operation, but the calculation has not been completed, flags F_TEND, F_WEND, F_IPZB and F_ISZOK in the PZ_LST data are left unchanged, while other flags F_TMOV, F_WMOV, F_IPZI and F_MPZ are cleared (S2353). If zooming with a constant image magnification is not being effected, or if the calculation has not been completed during zooming with a constant image magnification, flags F_TEND and F_WEND in the PZ_LST data are left unchanged, while other flags are cleared (S2355). The content of data PZ_LST is transmitted to the camera body 11 by means of a communication using the PZ-LSTATE(10) command.

The logical sum of the ZM-ST2 data and a predetermined data is stored in ZM-ST2. The start flag F_START, the zoom flag for constant image magnification, F_ISZ, the specified direction drive flag F_MOV-TARG, the specified position drive flags, F_MOVPLS and F_MOVZC, etc. are all cleared, after which the SET-ST operation is completed (S2357). This means, flags F_PZPOS and F_PZPDRC in the ZM-ST2 data are left unchanged, while other flags are cleared.

Flag F_PZDRC has the same function as those of flags F_DRCW and F_DRCT in the data of ZM-ST1. Flag F_PZDRC indicates that the lens is driven to the

wide end when F_PZDRC=1 and that the lens is driven to the tele end when F_PZDRC=0.

MOV-TRG OPERATION

The flow chart shown in FIG. 81 is the MOV-TRG operation for driving the zoom lens to a desired position. First, whether or not the targeted number of PZ pulses is greater than the present PZ pulse is checked (S2401). If it is greater, driving is effected in the telephoto direction, while if it is smaller, driving is effected in the wide-angle direction.

When the driving operation is effected in the telephoto direction, the targeted number of PZ pulses (PZPTRGT) is subtracted by the present number of pulses (PZPX), and the difference is stored in the memory (PZPDIF) as the number of driving pulses (S2403). If the targeted number of pulses and the present number of pulses are equal, the operation proceeds to NO-MOV (S2405) because the driving operation is not necessary. If they are not equal, the direction of the motor driving operation is temporarily set for the telephoto direction. If it is either in the telephoto end or in the pseudo-telephoto end, the operation proceeds to NO-MOV (S2407 through S2411). If it is neither the telephoto end nor pseudo-telephoto end, but during the driving operation, the operation proceeds to BRK1 if the wide direction flag F_DRCW is set, or if the battery is turned OFF (S2413 through S2417). If driving is being effected in the same direction, and if the battery is ON, the operation proceeds to DRV-TRG8 (S2413 through S2417). If it is not being driven, the operation proceeds to S2441.

When driving is being effected in the wide-angle direction, the targeted number of pulses (PZPTRGR) is subtracted from the present number of pulses (PZPX), and the difference is stored in the memory (PZPDIF) as the number of driving pulses (S2423). The driving direction of the zoom motor is then temporarily set for the wide-angle direction, and if it is in the wide terminal or in the pseudo-wide terminal, the operation proceeds to NO-MOV (S2427 through S2431).

If the lens is neither at the wide-angle end nor the pseudo-wide-angle end, but rather in the midst of the driving operation, the operation proceeds to BRK1, if the telephoto direction flag F_DRCT is ON or if the battery is turned ON (S2433 through S2437). If driving is being effected in the same direction, and if the battery is turned ON, the operation proceeds to DRV-TRG8 (S2433 through S2437). If driving is not currently being effected, the operation proceeds to S2441.

In this control method, the possibility exists that an excess pulse will occur as a result of the driving being changed to braking when the targeted PZ pulses and the present PZ pulses become equal. However, since an excess pulse is of minimal importance, the operation proceeds to NO-MOV1 when the difference pulse PZPDIF is 1, or when it is not 1 but the power supply is turned OFF (S2441 through S2443).

When the difference pulse PZPDIF is not 1, and when the power supply is ON, the brake counter T_BRK is incremented by 1, if the brake flag F_BRK is set. If the brake counter T_BRK is smaller than a predetermined value, the operation proceeds to the braking operation (BRK2 (S2443 through S2449 represent the foregoing processes)).

If the brake flag F_BRK has been cleared, or if the brake counter T_BRK is greater than a predetermined value, the brake operation is completed. The start-up flag F_START is set, and the limit timer and the PWM

timer are cleared. The counter is then set so that terminal detection is not performed for a certain period of time after start-up, and an initial value (i.e., the minimum value) is set for the PWM duty ratio (S2451). This means, the start flag F_START is set, the terminal detecting counter T_LMT and PWM counter T_PWM are cleared, an initial value is entered in the start counter T_START, and the minimum value is entered in the PWM duty ratio T_PWMBRK.

Upon completion of the setting operation, the LED of the PZ pulser 69 is turned ON to prepare for the PZ pulse counting. If the PZ pulse interruption is not enabled, it is enabled before proceeding to DRV-TRG8 (S2453 through S2457).

DRV-TRG8 OPERATION

The DRV-TRG8 operation shown in FIGS. 83 and 84 is an operation to control the speed according to the number of the driving PZ pulses until the targeted focal distance is reached, and in which speeds are changed in several steps in accordance with the number of pulses to the targeted position (PZPDIF). In this preferred embodiment, when the number of driving pulses to the target is equal to or above that of the third pulse, driving is done at the fourth speed (DC driving), which is the maximum speed. When it is less than that of the third pulse, but equal to or above that of the second pulse, driving is done at the third speed. When it is less than that of the second pulse, but equal to or above that of the first pulse, the second speed is selected. When it is less than that of the first pulse, the first speed is selected. In this operation, the fourth speed is greater than the third, which is greater than the second, which is greater than the first. The number of the third pulses is greater than the second, which is greater than the first. Also in this preferred embodiment, four speeds can be selected. However, the number of speeds may be more or less than four, or a large number of steps for effecting an almost continuously variable speed.

First, a speed selection operation (S2501) is performed in accordance with the selected zooming speed. That is to say, when the first speed is selected, the operation proceeds to step S2503, the second speed to step S2511, the third speed to step S2521, and the fourth speed to step S2541, respectively. The selection of the speed is based on the value in bits 2 and 3 (F_SPDA2 and F_SPDB2) of SPDDRC2.

SPDDRC2 is utilized when the target position has been set. The zooming direction, at the time when the lens starts to be driven, and the zooming speed, which is automatically set by the main CPU 35 or the lens CPU61, are set in the SPDDRC2.

When the first speed is selected, whether there are any changes in the speed and its driving direction (the value of ZM-ST1) is tested. If there are changes, the standard value for the first speed N_PWMMI0 is set at the PWM brake timer (PWM duty ratio). If there are no changes, nothing is done at this stage. Then the PZ pulse cycle N_PWMP0 of the first speed is set at T-PWMPLS, and the logical sum of R_INT and a predetermined data is stored in ZM-ST1 (i.e., setting of the speed and its direction (S2503 through S2509 represent the foregoing operations)). By means of the above operations, the slowest speed is selected. The logical sum of the PZ-LST data and a predetermined data is computed. Further, a logical sum of the above mentioned sum and the R_INT data is stored in the PZ-LST data, before the SET-ST operation is completed (S2551).

When the second speed is selected, whether the number of pulses to the target position is equal to or above that of the first pulses is tested. If it is smaller, the operation proceeds to DRVPWM0 (S2503 for the first speed). If it is equal to or above, the operation proceeds to step S2513, in which it is determined whether there are any changes in its speed or its direction (i.e., the value of ZM-ST1) is tested to control at the second speed. If there are any changes, the standard value of the second speed is set at PWM brake timer (PWM duty ratio). If there are no changes, an operation is not performed. Cycle N_PWMP1 of the PZ pulse for the second speed is then set at T-PWMPLS. The logical sum of the R_INT data and a predetermined data is stored in ZM-ST1 before proceeding to S2551, S2503 through S2509 represents the foregoing operations, wherein the second speed is selected.

When the third speed is selected, whether the number of pulses to the target position (PZPDIF) is less than that of the first pulses is tested. If it is smaller, the operation proceeds to step S2503 (DRVPWM0) for the first speed. If it is equal to or above the number of first pulses, and less than that of the second pulses, the operation proceeds to DRVPWM1 for the second speed operation (S2521 and S2523). If it is equal to or above the number of second pulses, the control is performed at the third speed. Whether there are any changes in speed and direction (i.e., the value of ZM-ST1) is tested. If there are any changes, the standard value, N_PWMMI2 of the third speed, is set at PWM brake timer (PWM duty ratio). If there are no changes, no operation is performed. The cycle N_PWMP2 of the PZ pulse for the third speed is then set at T-PWMPLS. The logical sum of the R_INT data and predetermined data is stored in ZM-ST1 before proceeding to step S2551. Steps S2523 through S2531 represent the foregoing operations, wherein the third speed is selected.

When the fourth speed is selected, whether the number of pulses to the target (PZPDIF) is equal to or above that of the first pulses is tested. If it is less than the number of first pulses, the operation proceeds to step S2503 (DRVPWM0) for the first speed processing. If it is equal to or above the number of the first pulses, and less than the number of the second pulses, the operation proceeds to DRVPMW1 for the second speed processing. If it is equal to or above the number of the second pulses, and less than the number of the third pulses, the operation proceeds to DRVPMW2. If it is equal to or above the number of third pulses, the maximum value N_PWMMAX is set at the PWM brake timer (PWM duty ratio), and the logical sum of R_INT data and a predetermined data is set at ZM-ST1, before proceeding to step S2551. Steps S2547 and S2549 represent the foregoing operations. The fourth speed (DC drive) is selected.

PZP-CNT OPERATION

PZP-CNT flow charts shown in FIGS. 85 through 89 are for operations regarding the PZ pulse count. These are the details of step S335 in the interruption routine for a 2 ms timer in FIG. 10.

To calibrate the PZ pulse (i.e., when F_PZ-PADJ=0) when the zoom lens group 53Z is at the wide-angle end, the present PZ pulse value and the PZ pulse count starting value are reset to zero. Then, if flag F_PZPOS, which shows whether the present position is known, has been set, the operation proceeds to PZP-CNT5. If the present position flag has been cleared, the

operation proceeds to the initializing operation (PZ-INIT) of the power zoom (S2601 through S2605 and S2615 represent the foregoing operations). When the calibration is not carried out, if the present position is known (i.e., when F_PZPOS=1), the operation proceeds to the present-position OK operation (POS-OK). IF the present position is unknown (F_PZPOS=0), the operation proceeds to the present-position unknown operation (POS-NG (S2603 and S2607 represent the foregoing operations)).

Likewise, to calibrate the PZ pulse when the zoom lens is at the telephoto end, the present PZ pulse value and the PZ pulse count starting value are set to the maximum (N_PZPMAX). If the flag that shows the present position as being known has been set, the operation proceeds to the PZP-CNT5. If the flag has been cleared, the operation proceeds to the PZ initializing operation (PZ-INT (S2609, S2611, S2613, and S2615 represent the foregoing operations)). When no calibration is needed, if the present position is known (i.e., when the flag is on), the operation proceeds to the present-position OK operation (POS-OK), but if the present position is not known, the operation proceeds to the present-position unknown (POS-NG) operation (S2611 and S2607). As explained above, when the zoom lens group 53Z is at the wide-angle end (F_WEND=1), or at the telephoto end (F_TEND=1), the PZ pulse is calibrated with a predetermined value. F_PZPADJ is a flag for testing, and when F_PZPADJ=1, the calibration is not performed.

When the lens is neither at the telephoto end nor at the wide-angle end, if the present position is known, the operation proceeds to the present-position OK operation (POS-OK), but if the present position is unknown, the operation proceeds to the present-position unknown operation (POS-NG (S2601, S2611 and S2607 represent the foregoing operations)).

POS-NG AND PZ-INIT OPERATIONS

POS-NG and PZ-INIT, shown in FIGS. 86 and 87, are operations that are effective when the present position is unknown, or when the telephoto end or wide-angle end has been reached.

The POS-NG and PZ-INIT operations are executed when the present position of the zoom lens is unknown. Usually, if the present position is not known, the POS-NG and PZ-INIT operations are also executed when the initializing command PZ-INITPOS (32) is transmitted from the camera body when the main switch in the camera body is turned on, or when the zooming operation is switched from manual to power.

In this preferred embodiment, when the PZ-INIT-POS command is transmitted, the zoom lens group 53Z is moved towards the telephoto end at the slowest speed. The present position of the zoom lens group can be detected by storing the number of absolute PZ pulses in a certain address (PZPX and PZPSTRT) at the position where the first divisional point 72 of the zoom code plate 71 or the telephoto end is detected. Further, in this embodiment, the zoom lens group 53Z is returned to its original position after detecting the present position. This can be done by the following procedures: when the PZ-INITPOS command is transmitted, a counter (PZPAZB) is cleared (making it zero) the first divisional point on the zoom code plate or the PZ o pulse to the telephoto end is counted, and the zoom lens is returned from that position (i.e., when the present position is detected) to the position with which the count

corresponds. This returning operation of the zoom lens is performed in the PZ-INIT operation (especially in S2637 through S2649).

The operation of the zoom lens at the slowest speed is executed by the PZ-INITPOS command through communication.

In this preferred embodiment, the lens is driven towards the telephoto end in a uniform manner to detect the present position. However, this may be towards the wide-angle end, or either direction may be selected based on other conditions.

Furthermore, in this preferred embodiment, when the present position is unknown, it can be detected automatically (i.e., the present position can be known), even if the P-INITPOS command is not transmitted from the camera body 51 at the time the lens has reached at a divisional point on the zoom code plate or the terminal points (i.e., far side and/or near side) when the manual power zoom is operated.

When the operation enters the POS-NG operation, if the start flag F_START has been set (i.e., at the time the zoom motor is activated), the PZ pulse conversion value (i.e., roughly detected PZ pulse value) on the zoom code plate 71, which is read-in for the operation, is set at the present position and the start pulse counter. The operation proceeds to the zoom driving operation (DRIVSTART1 (S2621 and S2623 represent the foregoing operations)).

The following operation is performed when the start flag F_START is set OFF: When the zoom code is the same as the previous one, the switching point has not been reached. The execution then exits the PZP-CNT operation (S2623 and S2625). When the zoom code has been changed (i.e., when at the divisional point on the code plate), the PZ pulse conversion value of the zoom code, which is entered for the present operation, is entered at the present PZ pulse value (PZPX) and PZ pulse count starting value (PZPSTRT), if the driving is toward the telephoto side (F_PZPDRC=0). If the driving is toward the wide-angle side (F_PZPDRC=1), the PZ pulse conversion value of the zoom code that was entered previously, is entered at the PZ pulse value (PZPX) and the PZ pulse count starting value (PZPSTRT (S2627 through S2631 represent the foregoing operations)).

When the move flag (F_MOV) has been cleared (i.e., when the PZ-INITPOS command has not been transmitted), or when flag F_PZPINIT has been set, flag F_PZPOS, which indicates recognition of the present position, is set when flag F_PZPINIT has been set before proceeding to the pulse count (PZP-CNT5) operation (S2633, S2635 and S2649).

When move flag F_MOV has been set (i.e., the PZ-INITPOS command has been transmitted), and when the present position flag F_PZPINIT has been turned OFF, the targeted PZ pulse (PZPTRGT) is the present PZ pulse value (i.e., the code plate border value) subtracted by the PZ pulse count value (PZPAZB) from the original position before the PZ initializing to the border position on the code plate (S2633, S2635 and S2637). The F_PZPINIT is a flag for disabling the initializing operation of PZ, and is used for testing. When F_PZPINIT=1, the operation is disabled.

A borrow in the above subtraction is indicative of an error in the counting process. In such a case, the targeted number of PZ pulses is set to zero to clear the drive flag F_MOV. If there is no borrow, the move flag is cleared without any other processing (S2639 and

S2641). Then, the move flag for the target value (F—MOVTRG) is set ON, the PZ speed is set to the first speed (the slowest speed), and the present position flag is set ON, after which the operation proceeds to the PZP-CNT5 operation (S2643 through S2649).

When the operation starts at the PZ-INIT operation, S2633 is the starting set.

POS-OK AND DRVSTRT1 OPERATIONS

The POS-OK operation shown in FIG. 88 is the PZ pulse counting operation in which the present position is known.

When the operation has already started (i.e., the start flag has been cleared), the operation proceeds to the PZ pulse calibrating operation (PZP-ADJ operation). When the operation is about to start, if the driving operation is effected in the telephoto direction (F_PZPDRC=0), the sum of the PZ pulse count starting value (PZPSTRT) and the PZ pulse count value (PZPCNT) is entered into the PZ pulse count starting value (PZPATRT) and into the present PZ pulse count value (PZPX). If the driving operation is effected in the side-angle direction (F_PZPDRC=1), the PZ pulse count starting value (PZPSTRT) is subtracted by the PZ pulse count value (PZPCNT) and entered into the PZ pulse count starting value (PZPSTRT) and into the present PZ pulse count value (PZPX (S2651 through S2657 represent the foregoing operations)).

Start flag F_START is then cleared, and the power zooming direction flag F_PZPDRC is cleared (i.e., the telephoto direction is selected) when the driving operation is effected in the telephoto direction (i.e., the direction toward which the lens is going to move this time). If the movement is effected in the wide-angle direction (i.e., the current direction towards which the lens is going), the power zooming direction flag F_PZPDRC is set (i.e., the wide-angle direction is selected (S2659 through S2665 represent the foregoing operations)).

When the operation begins from DRVSTRT1, step S2659 is the first step. The start flag is cleared, and the driving direction is set in steps S2659 through S2665.

PZP-ADJ AND PZP-CNT5 OPERATIONS

The PZP-ADJ operation, shown in FIG. 89, is for calibrating calculation errors of the PZ pulse count.

The zoom code is first checked if it is the same as the previous code. If it is the same, the flow exits the PZP-ADJ operation because calibration is impossible. If it is different, the calibration operation continues, provided that the PZP calibration disabling flag F_PZPADJ has been cleared, i.e. waits until it exceeds the divisional region (border) of the code plate 71. In this operation, the PZP calibration disabling flag F_PZPADJ is for testing, and is usually cleared.

If the direction of the power zooming operation is towards the telephoto direction, the present pulse conversion value of the zoom code is stored in register Y if the direction is towards the wide-angle direction, the previous pulse conversion value of the zoom code is stored in register X, and the value in register X is stored in the accumulator to check if the absolute value of the difference between this value and the PZ pulse value is within the calibration limit (S2679 through S2683). If it exceeds the calibration limit, the value of register X is stored in the present PZ pulse value and in the PZ pulse count starting value to perform a calibration. If it is within the calibration limit, no calibration is performed. The PZ pulse count value (PZPCNT) is cleared, and

the number of the PZ pulses at the present focal distance is converted to the present focal distance (mm), based on table data. It is then stored in FCLXL and H, after which the execution quits the PZP-CNT operation (S2685 through S2689 represent the foregoing operations)).

When the operation starts from PZP-CNT5, step S2683 is the first step in which the PZ pulse count value is cleared, the number of pulses of the present focal distance is converted to the present focal distance (mm), and then stored, after which the execution quits the PZP-CNT operation (S2685 through S2689).

When there is an instruction to execute a PZ pulse initializing operation by the above mentioned PZ-INIT-POS command from the body (i.e., when the body's main power is turned on), the zooming operation is performed toward the telephoto side. The present position PZ pulse value (PZPX) and the start position (PZPSTRT) can be selected by detecting the absolute position from the border position of the divisional region when it exceeds the divisional region of the code plate 71. Further, the original position can also be returned to after the present position has been detected.

While zooming, every time the border of the code plate 71 is exceeded, the absolute number of pulses at the border part is read-in from the table and compared with the count value. If the difference is greater than a predetermined value, calibration (alteration) is effected.

ISZMEMO OPERATION

The flow chart for the ISZMEMO operation, shown in FIG. 90, is an operation for storing image magnification values. In other words, it is an operation whereby, the present AF pulse value (AFPX) and the present focal length (FCLXL and H) are stored by effecting the zoom speed changing switch 75 or the set switch (SL switch, SW) when in the constant image magnification zooming mode. This operation is the detail of S359 in the interrupting routine for a 2 ms timer shown in FIG. 10.

In the preferred embodiment, the AF pulse value and the focal distance are stored at the time when the zoom ring is returned to the neutral position, provided an in-focus condition exists, or when the set switch is turned OFF, even if the zoom lens is not at the neutral position.

In the ISZMEMO operation, the image magnification lens memory flag F_ISM is set, and the constant image magnification mode is selected. The operation then proceeds to storing operations step S2707 and beyond, provided that the in-focus flag F_AFIN has been set (S2701 through S2705). The image magnification lens memory flag F_ISM is transmitted from the body by command PZ-BSTATE(20) and is stored in PZ-BDST.

The image magnification memory flag F_ISM is usually transmitted after being cleared. Storing of the image magnification memory for the present AF pulse value and the present focal distance is not performed by the lens alone, but is performed when the command ISZ-MEMORY(36) is transmitted from the body. Furthermore, the transmission of the command ISZ-MEMORY(36) takes place when the zoom speed switch 75 has returned to the neutral position or when the set switch SL is turned OFF after the body checks Bit 2 (SLSW) of the periodical communication POFSTATE(11) and Bits 0 and 1 (PTSW and PWSW) of LENS-INF1(13) to determine whether the set switch

SL (SL switch) and the zoom speed switch 75 are turned ON or OFF.

As explained above, when the flag F_ISM is set and transmitted, the image magnification is stored by the lens after determining whether the set switch SL and zoom speed switch 75 are ON or OFF, not by the command ISZ-MEMORY from the body.

When the zoom switch 75 has just been returned to the neutral position, after being in some position other than the neutral position, or when the set switch, which was previously ON, has just been turned OFF, the present value of the AF pulse is stored at address ISZ-AFPL and H. The present focal distance is then stored at address ISZ-FCLL and H, and the image magnification calculation instruction flag F_ISM is set before the ISZMEMO operation is terminated (S2707 through S2719).

In other words, the image magnification is stored in the memory at the time when the zoom switch 75 has returned from the telephoto or wide-angle side to the neutral position, provided that an in-focus condition exists and the flag F_ISM has been set, or when the set switch is turned off.

MTL-CTL OPERATION

The MTL-CTL flow chart, shown in FIG. 91, is an operation that controls the driving operation of the zoom motor 65 corresponding to the zoom motor control flags (i.e., each flag of ZM-ST1) which have been set by the SET-ST operation. This operation is the detail of S363 in the interruption routine for the 2-ms timer shown in FIG. 10.

When drive flag F_DRV has been cleared and when the brake flag F_BRK has been set, the brake is applied to the zoom motor 65. When brake flag F_BRK has been cleared, a 2-ms timer is started after the zoom motor 65 is released. Then, the interruption for the 2 ms timer is enabled, and the PWM interruption is disabled before completing the operation (S2801, S2809 through S2813, S2817 and S2819 represent the foregoing operations).

When the drive flag F_DRV has been set, and if it is set for telephoto, the zoom motor 65 drives the lens toward the telephoto end. If it is set for wide-angle, the zoom motor 65 drives the lens toward the wide-angle end (S2801 through S2807).

When the motor is actuated at the fourth speed (DC drive), the 2 ms timer is started, the 2 ms timer interruption is enabled, and the PWM interruption is disabled, before completing the operation (S2815, S2817 and S2819).

When the motor is driven at the first through fourth speeds, the PWM hard timer is incremented by 1. When the incremental value overflows, the maximum value (FFH) is assigned to the PWM hard timer. If overflow has not occurred, the incremental value is maintained (S2815, S2821 through S2825).

Next, whether the PWM hard timer value (T_PWM) has exceeded the PWM's PZ pulse cycle (T_PWMPLS) is determined (i.e., whether the PZ pulse is transmitted within the PZ pulse cycle time of PWM). If it is exceeded, the duty ratio (T_PWMBRK) is increased because the pulse has not been transmitted within the cycle time. If it is not exceeded, the duty ratio (T_PWMBRK) is set as it is in the hard timer for PWM control, and the hard timer for PWM control is started (S2827 through S2833). Then, the 2 ms timer is started, interruption for the 2 ms timer is enabled, and

PWM interruption is enabled before the operation is completed (S2835 and S2837).

RELEASE OPERATION

The following explains the release operation of the camera body 11, as shown in FIG. 92. This release operation is executed by the main CPU 35, provided that the release switch SWR is turned ON.

First it is determined whether mid-exposure manual power zooming is possible, based on the data stored in the E²PROM, etc. In response to the determination, predetermined data is transmitted to the lens by the BODY-STATE1 command (S2901, S2903 and S2905). When mid-exposure manual power zooming is possible, MPZ disabling flag (MPZD) is cleared, control zooming halt flag (IPZD) is set, and BODY-STATE1 data, in which during-release flag (REL) has been set, is transmitted (S2905). When mid-exposure manual power zooming is not possible, MPZ disabling flag (MPZD) is set, control zooming halt flag (IPZD) is set, and BODY-STATE1 data, in which during-release flag (REL) has been set, is transmitted (S2903). If it is known through this communication that control zooming (i.e., zooming with constant image magnification or preset zooming) is being effected, control zooming is stopped.

In this embodiment, by setting the control zooming halt flag and sending it to the lens by way of the body state 1 command, substantially the same action as that which occurs when sending the IPZ-STOP command in the instruction command can be carried out. However, it is also possible to stop the zooming by an IPZ-STOP command.

Next, flag F_IPZB is checked by means of transmission of the PZ_LSTATE command to determine whether control zooming (i.e., zooming with constant image magnification or preset zooming) has been completed (S2904-1 to 2). Upon completion, flag F_ISZON for zooming with constant image magnification and flag F_IPZON for preset zooming are cleared, and the battery request in the body flag is cleared before the power supply by the battery is halted (S2904-3 through 6).

Mirror 13 is then lifted up by the mirror motor, and the iris diaphragm is closed by the diaphragm driving mechanism. After these operations are completed, it is checked whether mid-exposure zooming is being effected by operating the first blind of the exposure mechanism 27 (S2907, S2909 and S2911). If mid-exposure zooming is being effected, operations in steps S2913 through S2923 are executed.

MID-EXPOSURE ZOOMING

The operation of mid-exposure zooming will be further explained below, referring to the timing chart in FIG. 93. In mid-exposure zooming, a zooming speed is selected in accordance with the exposure time provided that the exposure time (shutter speed) is longer than a predetermined time (e.g. 1/60 seconds). Then, the direction of the power zoom (i.e., TELE direction or WIDE direction) is selected, power is supplied to the power zoom lens 51, it is determined whether power is being supplied in a normal manner. Then, a delay equal to one-half of the exposure time is effected, provided that the power supply is normal (S2911, S2913 through S2923).

When one-half of the exposure time has elapsed, the data for zooming speed and its direction, which have been set in S2915 and S2917, is transmitted to the power

zoom lens 51 by the MOVE-PZMD communication command, power zooming of the power zoom lens 51 is activated, and the full exposure time is awaited (S2923 through S2927).

Upon expiration of the exposure time (i.e., the second blind finishes running), manual power zooming is disabled and mid-exposure zooming is halted by the BODY-STATE1 communication (S2929). Next, whether the mid-exposure zooming has been stopped is determined by checking flag IPZB using the PZ-LSTATE data communication (S2929 through S2931). When confirming a complete stop (IPZB=0), the battery request flag of the body is cleared, and the power supply from the battery is stopped (S2931 through S2933). Then, the mirror motor 33 and the film winding motor 25 are driven to retract the mirror and to wind the film, respectively. Manual power zooming is enabled by the BODY-STATE1 communication before control is returned (S2934 through S2937).

In this preferred embodiment, the exposure time for mid-exposure zooming is 1/60 second and above. However, the time is not limited to it. Likewise, although the zooming speed is changed according to the exposure time, it does not have to be changed. Although power zooming is started after one-half of the exposure time has passed, the timing of the start and end of power zooming may be decided arbitrarily.

PZ MODE SWITCHING OPERATION

The power zoom (PZ) mode switching operation of the camera body 11, shown in FIG. 94, will be explained below. This PZ mode switching operation is executed in S1507 of the PZ loop operation shown in FIG. 60A, and the PZ mode changing operation is executed when the mode switch 77 of the photographing lens 51 is operated. In this preferred embodiment, there are five kinds of zooming modes; the manual zooming or manual-power zooming, constant image magnification zooming, preset zooming, preset zoom setting and mid-exposure zooming modes. In this flow chart, each mode has a number; No. 0 is the manual zooming or manual-power zooming mode, No. 1 is the constant image magnification zooming mode, No. 2 is the preset zooming mode, No.3 is the preset zooming setting mode, and NO. 4 is the mid-exposure zooming mode.

First, it is determined if the mounted lens is a power zoom lens and if the zoom mode is a manual zoom mode or a power zoom mode, if so, it is then determined if the power zoom lens is a manual power zoom (i.e., electric motor driven zoom) or auto-power zoom. If the lens is a power zoom lens, or power zoom lens but not automatic power zoom, the power zoom mode flag is cleared. The operation maintains these conditions and control is returned (S3001, S3035 and S3039).

If the lens is an auto-power zoom lens, the already preserved mode is retrieved. If it is in the auto-focus mode, no processing takes place. However, if it is not in the auto-focus mode, constant image magnification zooming cannot be performed. Therefore, if the retrieved PZ mode is the constant image magnification zooming mode (I), it is changed to an upper mode. If it is not the PZ mode, no operation takes place (S3090 through S3013).

Next, when up and down switches SWUP and SWDN are turned ON, a changing operation of the PZ mode is performed (S3015 through S3029) provided that the SWAS switch (i.e., zoom mode switch) of the

power zoom lens 51 is turned ON. For instance, when the down switch SWDN is turned ON, the zoom mode is changed upward until it becomes No. 4 (S3017, S3031 and S3033). When the UP switch SWUP is turned ON, the zoom mode is changed downward until it becomes No. 1. However, when it is not in the auto-focus mode, constant image magnification is not selected (S3019 through S3029).

Upon completion of the UP/DOWN operation, the selected mode number is preserved, control is then returned (S3039). The state of the switch SWAS is included in data transmitted by the POFF-STATE communication.

THE PZ PULSE COUNT INTERRUPTION OPERATION

The following explains the PZ pulse count interruption operation shown in FIGS. 95 and 96, which is executed in the photographing lens 51. This interruption takes place at the upright of a PZ pulse output, the counting of which is performed by software. The interruption may be performed at the downfall of a pulse, depending on the setting of the lens CPU.

First, the interruption is disabled, and the PZ counter (PZPA2B), which counts the PZ pulses in the PZ initializing operation, and the PZ pulse count value (PZPCNT) are incremented by 1. When the PZ pulse counter value overflows, the maximum value is entered in the PZ pulse count value (S3101 through S3109).

Next, the driving direction of the power zoom lens is checked. If it is in the telephoto direction, the PZ pulse count starting value is added by the PZ pulse count value and entered into the present PZ pulse value. If it is the wide-angle direction, the PZ pulse count starting value is subtracted by the PZ pulse count value and entered into the present PZ pulse value (S3111 through S3115).

Then, when the driving operation is not being performed (F_DRV=0), the operation proceeds to the PWM control checking (CHKPWM) in S3117. When the driving operation is being performed, but the constant image magnification zooming is being effected, or driving is not towards the targeted position, the operation proceeds to the PWM control checking operation (CHKPWM) in S3117 through S3121. When the constant image magnification zooming is being effected or the driving operation is towards the targeted position, the number of the present PZ pulse and the number of the targeted PZ pulse are not equal, and the operation proceeds to the PWM control checking (CHKPWM). If they are equal, the operation proceeds to the braking operation (BRAK) to stop the zoom motor immediately (S3117, S3119 and S3123).

THE BREAK AND CHKPWM OPERATIONS

FIG. 96 shows a flow chart regarding the braking operation (BREAK operation) of the zoom motor and the PWM checking operation. These operations are to reduce the speed of the PZ motor.

In the braking operation, the brake is first applied to the zoom motor (by closing the input terminal of the zoom motor), and the brake data is entered into ZM-ST1. For brake data, F_BRK is set, flag F_LMTT and F_LMTW remain unchanged, and the others are cleared (S3151 and S3153 represent these operations).

The PWM timer, the limit timer, and the start timer are cleared. Data for the present focal distance is obtained from the present PZ pulse value (PZPX) and

stored in FCLXL and H, after which the interruption is enabled before control is returned (S3155 through S3159).

The CHPWM operation reduces the duty ratio in the PWM control. When the PWM driving is not in operation, the operation proceeds to S3155 with the fourth speed (DC) unchanged. When the PWM driving is in operation, if the PWM timer (T-PWM) is less than the PWM pulse cycle (T-PWMPLS), the duty ratio is reduced because the power zooming speed is too high. The operation then proceeds to S3155. If the PWM timer is greater than the PWM pulse cycle, the operation proceeds to S3155 without any further processes (S3161 through S3165 represent the foregoing operations).

Many functions of this preferred embodiment were explained in the foregoing paragraphs. A part or all of these functions may be built into a single camera system (i.e., a camera body and a photographing lens).

According to the present invention, it is possible to provide various kinds of controls in the power zoom lens in closer coordination with the camera body, because communication means to communicate commands and data with the camera body is built in both the camera body and the power zoom lens, which is detachably attached to the camera body.

As can be seen from the above discussion, in a power zoom single lens reflex camera according to the present invention, since the detection time of the extreme position of the motor driven lens varies in accordance with the number of revolutions of the zoom motor 69, which is controlled by the PWM control in such a way that the detection time decreases as the number of revolutions of the zoom motor increases, the load on the zoom motor 69 is decreased when the lens reaches one of the extremities at high speed rotation of the zoom motor. On the other hand, since the extreme position is detected when no rotation of the zoom motor occurs, even during the longest power supply time (maximum drive torque), the extreme positions can be assuredly detected.

If a movement of the zooming lens group 53Z cannot be effected at an intermediate position between the telephoto extremity and the wide angle extremity, dur-

ing the power zooming operation, the stopping of the zooming lens group at a point other than the two extreme positions is detected by the zoom code 71. In this regard, if the zooming lens group which has moved toward the telephoto extremity is stopped at an intermediate point, the pseudo telephoto extremity flag F-LMTT is set, and if the stopping of the zooming lens group which has moved toward the wide angle extremity occurs, the pseudo wide-angle extremity flag FLMTW is set to thereby discriminate between the telephoto extremity and the wide angle extremity, respectively. Thereafter, the zoom motor is stopped. If the zoom motor restarts in accordance with a certain operation or control, the pseudo telephoto extremity flag F-LMTT and the pseudo wide-angle extremity flag F-LMTW are cleared. Accordingly, a further movement of the zooming lens group toward either the telephoto extremity or the wide angle extremity is made possible.

An extremity detecting apparatus according to the present invention can be generally applied to a motor driven lens in which a lens is driven by a motor, such as a power zoom mechanism or an automatic focusing device.

TABLE 1

I	Instruction Name	Instruction Code
0	STANDBY	30
1	AF-INITPOS	31
2	PZ-INITPOS	32
3	RETRACT-PZ	33
4	RET-PZPOS	34
5	IPZ-STOP	35
6	ISZ-MEMORY	36
7	ISZ-START	37

TABLE 2

No	Instruction Name	Instruction Code
0	LROM 16 byte data	40
1	LROM first half 8 byte data	41
2	LROM second half 8 byte data	42

TABLE 3

B L	BL COMMAND	Command Code	Data Bit								dimen- sion	
			B7	B6	B5	B4	B3	B2	B1	B0		
0	PZ-BSTATE	20	ISM 1: lens 0: body	AFif yes no	Mobj yes no	ovAF yes no	toFm yes no	toNm yes no	endF yes no	endN yes no	—	
1	BODY-STATE0	21	m AF 1: C 0: S	swAF A M	BATT yes no	swS off on	Vdd on off	IPZC 4	IPZB 2	IPZA 1	—	
2	BODY-STATE1	22	ISsp SP B ISZM	ISsp SP A FM2	ISZD AFx FM1	AF-L pre off	MPZD stop ena.	IPZD stop ena.	WIND yes no	REL yes no	—	
3	SET-AFPOINT.	23	ISZM	FM2	FM1	FM0	X					
4	SET-PZPOIN.	24	ISZM	FM2	FM1	FM0	X					
5	STORE-AFP	25	ISZM 128	AM2 64	AM1 32	AM0 16	2048 8	1024 4	512 2	256 1	Pulse	
6	STORE-DEFP&D	26	SIGN 128	64	32	16	4096 8	2048 4	1024 2	512 1	256 1	×4 μm
7	STORE-PZP	27	AFM 1: memo 0: no	AM2 4	AM1 2	AM0 1	PZM memo	FM2 4	FM1 2	FM0 1	—	
8	STORE-PZF	28	ISZM 128	FM2 64	FM1 32	FM0 16	8	1024 4	512 2	256 1	mm	
9	STORE-IS	29					2	1	½	¼	times	
A	MOVE-PZMD	2A	1/ 8 SP B 1: 0:	16 SP A	32 MD W	64 MD T	128 MD M	256 MvM2	512 MvM1	1024 MvM0	—	

TABLE 6-continued

	MOVE-pzf HIGH	ISMW	ISMT	ISDC	ISDB	ISDA	LENS	PWSW	PTSW						
	MOV_PZMD (BL3)				PZ_LST (LBA)										
	MDM	MPZ	ISOK	IPZI	IPZB	WEND	TEND	WMOV	TMOV						
	ST_PZP (BL4)				SCRIN_IN (BLF)										
	for STORE-PZP				for secret data input										
	ST_DEFPL (BL5)				SCRIN_OUT (LBF)										
	AF defocus pulse of body LOW				for secret data output										
	ST_DEFPH (BL5)				BD_VER										
	AF defocus pulse of body HIGH				for BODY VERSION input										
	ST_DEFL (BL5)				FLG1										
	AF defocus amount of body LOW	un-	GET	REC	BNK	RLT	RLT	OPON	OP						
	ST_DEFH (BL5)	used	CMD	ALC	ON	BNK			BNK						
AF	AF defocus amount of body HIGH				FLG2										
DRC				unused			STN	SCK	CMD						
	ST_PZFL (BL6)						DBY	NG	NG						
	STORE-pzf LOW				COMMAND										
	ST_PZFH (BL6)				BODY → LENS COMMAND										
	STORE-pzf HIGH				TST_ADRH										
	ST_AFPL (BL7)				test address data LOW										
	STORE-AFP LOW				TST_ADRL										
	ST_AFPH (BL7)				test address data HIGH										
	STORE-AFP HIGH				TST_DATA										
	PZ_BDST (BL9)				test WRITE data										
ISM	AFIF	MOBJ	OFAF	FARM	NEA	ENDF	ENDN	PZP	AFP	DM	LMT	REV	PZI	PZP	AFP
				RM				CNT	CNT		DTC		NIT	ADJ	ADJ
											TST_FLG1				
											TST_FLG2				
ISMO	IFO	MOB	OVA	FAR	NER	END	END	PUL	PUL	IO	ZMSW	ZMC	DISC	MTR	SET
		JO	FO	MO	RMO	FO	NO	LUP	LDN					CTL	ST

TABLE 7

			R_ZOOM	ZM_ST1							AFPSTRTL				
LMTW	LMTT	DRV	BRK	SPD1	SPD0	DRCW	DRCT				counter start position	AF pulse	LOW		
			SPDDRC1								AFPSTRTH		HIGH		
		zoom speed direction		SPD	SPD	WID	TEL								
		register 1		B1	A1	E1	E1								
			SPDDRC2								AFP CNTL				
		zoom speed direction		SPD	SPD	WID	TEL				AF pulse counter	LOW			
		register 2		B2	A2	E2	E2								
			TRNSSPD								AFP CNTH		HIGH		
		zoom speed SW trans-	SPDB	SPDA	WIDE	TELE									
		formed value									AFPXL				
MPZO	IS	IPZ	IPZ	WEN	TEN	WMO	TMO				AF pulse present position	LOW			
	OKO	IO	BO	DO	DO	VO	VO								
			ZM_ST2								AFPXH		HIGH		
un-	MOV	MOV	MOV	ISZ	STA	PZP	PZ				AF pulse present position	HIGH			
used	ZC	TRG		RT	RT	DRC	POS								
			ZM_ST3								AFPA2BL				
		unused				REVW	REVT				AF pulse generic counter	LOW			
			T_LMT								AFPA2BH		HIGH		
		end point detecting timer (counter)									AFP CDL				
			T_BRK								distance code AF pulse transformed value	LOW			
		zoom motor braking time timer (counter)									AFP CDH		HIGH		
			T_PWM												
		PWM timer (counter)									AFP DIFL				
			T_PWMPLS								difference between distance code transformed	LOW			
		PWM PZ pulse period (interval)									value and present position				
			T_PWMBRK								AFP DIFH		HIGH		
		PWM brake timer value (PWM duty ratio)									PZPSTRT				
			T_START								PZ pulse at counter start position				
		zoom motor start-up timer (counter)									PZPCNT				
			T_REV								PZ pulse counter				
		zoom motor reverse timer									PZPX				
			ZM_MODE								present position PZ pulse				
		zoom mode									PZPA2B				
			ZM_DATA								PZ pulse generic counter				
		zoom data													

TABLE 8

	PZPCD	ISZ_AFPL
	zoom code PZ pulse transformed value	ISZ AF pulse LOW
	PZPDIF	ISZ_AFPH
	difference between target and present value	HIGH
	PZPTRGT	ISZ_FCLL
	target PZ pulse	ISZ focal length LOW
	PZPF	ISZ_FCLH

TABLE 8-continued

target PZ pulse (present value calculate)							ISZ_IMGL	HIGH	
PZPFPRE							ISZ image size	LOW	
target PZ pulse (predictor calculate)							ISZ_IMGX	HIGH	
FCLXL							FCLL	LOW	
present focal length							FCLH	HIGH	
LOW									
FCLXH									
ISZ_ST									
HIGH									
FPRE	FPRE	ISZ	ISZ	ISZ	STIS	1st	AF	focal length for PZ pulse transform	LOW
OK		XOM	FOM	M		AFP	POS		HIGH
CD_DSNEW							UNVCNTR		
present distance code (remove chattering)							universal counter		
CD_DSOLD							REGC		
previous distance code (remove chattering)							generic register C (inhibited to be used other than MAIN)		
CD_DSN							REGD		
present distance code							generic register D (inhibited to be used other than MAIN)		
CD_DSO							REGE		
previous distance code							generic register E (inhibited to be used other than MAIN)		
CD_ZMNEW							R_BE		
present zoom code (remove chattering)							generic register R_BE (inhibited to be used other than MAIN)		
CD_ZMOLD							R_CE		
previous zoom code (remove chattering)							generic register R_CE (inhibited to be used other than MAIN)		
CD_ZMN							SFT_L		
present zoom code							generic register SFT_L (inhibited to be used other than MAIN)		
CD_ZMO							SFT_M		
previous zoom code							generic register SFT_M (inhibited to be used other than MAIN)		

TABLE 9

R_DEFL	stack area	
for calculation of FPPE X		
R_DEFH		
for calculation of FPPE X		35
R_STO		
for serial communication timer-over		
R_DHEN		
for LSB → MSB data transform		
R_ROOP		
for AE AF all data communication		40
R_VECTL		
for communication interrupt		
R_VECTH		
for communication interrupt		
R_LROML		
LROM first address	LOW	
R_LROMH		45
LROM first address	HIGH	
R_LROMNL		
LCO first address	LOW	
R_LROMNH		
LCO first address	HIGH	50
R_CONCM		
for storing command during CHBNK		
R_INT		
generic register (for timer interrupt)		
DUMMY		
for code plate, SW input, WAIT		55

TABLE 10

stack area	FCL0L	
	FCL0H	
	FCL1L	
	FCL1H	
	FCL2L	
	FCL2H	
	FCL3L	
	FCL3H	
	FCL4L	
	FCL4H	
	FCL5L	
	FCL5H	
	FCL6L	60

TABLE 10-continued

FCL6H	
FCL7L RETPOS	LOW
RET focal length for PZPOS	LOW
FCL7H RETPOSH	HIGH

TABLE 11

AFP0L	XOFOL	
	ISZ XOFO	LOW
AFP0H	XOFOM	
	ISZ XOFO	MIDDLE
AFP1L	XOFOH	
	ISZ XOFO	HIGH
AFP1H	ISZ_FPXL	
	PRE operation X	LOW
AFP2L	ISZ_FPXH	
	PRE operation X	HIGH
AFP2H	ISZ_FL	
	ISZ F result	LOW
AFP3L	ISZ_FH	
	ISZ F result	HIGH
AFP3H	ISZ_FPL	
	ISZ FPPE result	LOW
AFP4L	ISZ_FPH	
	ISZ FPPE result	HIGH
AFP4H		
AFP5L		
AFP5H		
AFP6L		
AFP6H		
AFP7L		
AFP7H		

We claim:

1. A camera system having a detachable lens, comprising:
 - a motor for driving the lens at a driving speed selected from a plurality of driving speeds;
 - a counter that counts a time in which a movement of the lens is impeded during an operation of said motor; and

means for controlling said motor driving the lens in response to said counter and for stopping said motor, in which said movement of the lens is impeded, depending on an actual driving speed of the motor and a predetermined driving speed of said plurality of driving speeds.

2. The camera system of claim 1, wherein said controlling means drives said motor at a constant operational speed.

3. The camera system of claim 1, wherein said predetermined period of time decreases as said actual driving speed of said motor increases.

4. The camera system of claim 1, further comprising means for setting a position of said lens to be identical to a movable limit when said motor is stopped, said controlling means preventing said motor from driving the lens in a direction of said movable limit.

5. The camera system of claim 1, wherein said lens comprises:

a lens group movable in a predetermined range along said optical axis direction;

means for selecting said driving speed of said lens group;

means for monitoring an actual driving speed of said lens group;

means for comparing said selected driving speed with said actual driving speed to determine whether said actual driving speed is equal to said selected driving speed;

means for detecting whether said lens group is at a limit position in accordance with an output of said monitoring means; and

means for controlling said driving speed of said lens group in accordance with an output of said comparing means, said controlling means determining a timing of a determination operation of said detecting means in accordance with said speed selected by said selecting means, said controlling means stopping said driving of said lens group in accordance with an output of said detecting means.

6. The camera system of claim 5, wherein said lens comprises:

a power zoom lens that includes a zooming lens group; and

a lens moving mechanism which holds and moves said zooming lens group in said optical axis direction, wherein said controlling means re-news said selected drive speed so that a re-newed drive speed is higher than said selected drive speed if said comparing means determines that said actual drive speed of said power zoom lens group differs from said drive speed selected by said selecting means, said controlling means initiating said determination operation by said detecting means under the condition that said renewed drive speed is a maximum drive speed.

7. The camera system of claim 1, wherein said detachable lens includes a movable lens group.

8. The camera system of claim 7, wherein said lens comprises a power zoom lens.

9. The camera system of claim 1, wherein said predetermined driving speed comprises a maximum driving speed of said motor.

10. The camera of claim 1, further comprising means for selecting a new driving speed that is higher than said selected driving speed when said movement of the lens is impeded.

11. A camera system having a detachable lens comprising:

a lens moving mechanism which supports and moves a lens group in an optical axis direction;

means for selecting a drive speed of said lens group from a plurality of driving speeds;

a motor that drives said lens moving mechanism at said selected drive speed;

a counter for counting a time in which a movement of said zooming lens group is impeded during an operation of said motor; and

means for controlling said motor to drive said lens moving mechanism and for stopping said motor, in which said movement of said lens moving mechanism is impeded in response to an output of said counter and a predetermined speed of said plurality of driving speeds.

12. The camera system of claim 11, wherein said controlling means drives said motor at a constant operational speed.

13. The camera system of claim 11, wherein said predetermined period of time decreases as said actual drive speed of said motor increases.

14. The camera system of claim 11, further comprising means for detecting a position of said zooming lens group.

15. The camera system of claim 12, further comprising means for detecting a movable limit of said zooming lens group.

16. The camera system of claim 15, wherein said camera body includes a battery which supplies said motor with power when said power zoom lens is mounted to said camera body.

17. The camera system of claim 16, wherein said camera body and said power zoom lens are provided with respective data communication means for transmitting power zoom data therebetween.

18. The camera system of claim 17, wherein said power zoom lens and said camera body comprise a lens controller for controlling said zooming lens group and a body controller for controlling said lens controller through said data communication means, respectively.

19. The camera system of claim 18, wherein said lens controller drives said motor at a constant speed in response to an output signal of said body controller.

20. The camera system of claim 18, wherein said lens controller outputs data regarding a discriminated movable limit to said body controller when said movable limit detecting means detects said movable limit, thereby stopping said motor.

21. The camera system of claim 13, wherein said power zoom lens comprises a power zoom operation switch which is actuated to select a direction of a power zooming and a zooming speed.

22. The camera system of claim 11, wherein said predetermined driving speed comprises a maximum driving speed of said motor.

23. The camera system of claim 11, further comprising means for selecting a new driving speed that is higher than said selected driving speed when said movement of the lens is impeded.

24. A lens drive control apparatus, comprising:

a lens group movable in a predetermined range along an optical axis direction;

means for selecting a driving speed of said lens group from a plurality of driving speeds;

means for driving said lens group at said selected driving speed;

means for monitoring an actual driving speed of said lens group;

means for comparing said selected driving speed with said actual driving speed to determine whether said actual driving speed corresponds to said selected driving speed;

means for detecting whether said lens group is at a limit position of the movable range in accordance with an output of said monitoring means; and

means for controlling said driving speed of said lens group selected by said selecting means in accordance with an output of said comparing means, said controlling means determining a timing of a detection operation of said detecting means in accordance with said speed selected by said selecting means, said controlling means stopping said driving of said lens group in accordance with an output of said detecting means.

25. The lens drive control apparatus of claim 24, wherein said controlling means re-news said selected drive speed so that a re-newed drive speed is higher than said selected drive speed if said comparing means determines that said actual drive speed of said lens group differs from said drive speed selected by said selecting means, said controlling means initiating said detection operation by said detecting means under the condition that said renewed drive speed is a maximum drive speed.

26. The lens drive control apparatus of claim 25, wherein said driving means comprises a motor, said controlling means setting a lens group drive speed at a minimum drive speed when said motor starts driving said lens group.

27. The lens drive control apparatus of claim 24, wherein said driving means comprises a motor, said monitoring means further comprising:

- means for generating a series of pulse signals having a time interval based upon a rotation of said motor; and
- means for measuring said time interval of said series of pulse signals, said comparing means comparing said measured time interval with said selected drive speed, said detecting means measuring a lapse of time after said monitoring means generates no se-

45

50

55

60

65

ries of pulse signals, such that if said lapse of time exceeds a predetermined value, said detecting means determines that said lens group is at said limit position of the movable range.

28. The lens drive control apparatus of claim 24, further comprising:

- means for detecting a position of said lens group, said detecting means comprising:
- means for determining whether said lens group is at said limit position when said lens group position detecting means detects said limit position, wherein said determining means determines that a present position of said lens group is a provisional limit position when said lens group position detecting means fails to detect said limit position, so that said controlling means stops said lens driving means in accordance with one of said limit position or said provisional limit position.

29. The lens drive control apparatus of claim 24, further comprising means for setting one of a driving direction of said lens along an optical axis of said lens group or a neutral position of said lens group along said optical axis of said lens group, wherein said controlling means prohibits said driving means from moving said lens group in a direction that is the same as a direction immediately prior to a stopping of said lens driving means if said controlling means detects one of said limit position or said provisional limit position, said limit position detection being canceled when said driving direction setting means sets a driving direction that is opposite said driving direction immediately prior to said stopping of said lens driving means, said provisional limit position being canceled when said neutral position is set by said driving direction setting means.

30. The lens drive control apparatus of claim 24, wherein said controlling means prohibits said determining means from determining a predetermined duration of time that begins with a starting of a motor of said lens driving means.

31. The lens drive control apparatus of claim 24, wherein said detecting means detects whether said lens is at a limit position of said movable range by determining whether said lens is moving.

* * * * *