

Nikon F3

REPAIR MANUAL



NIPPON KOGAKU K.K.

Tokyo, Japan

© Copyright 1980
ALL RIGHTS RESERVED
無断転載を禁ず!!

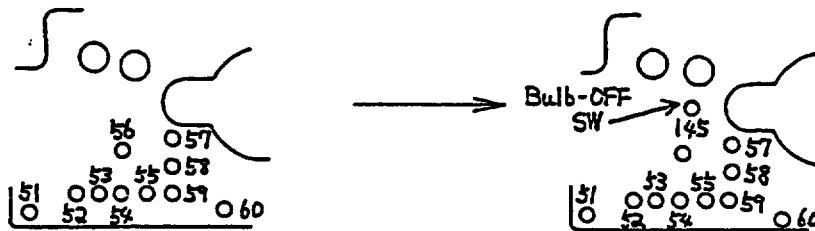
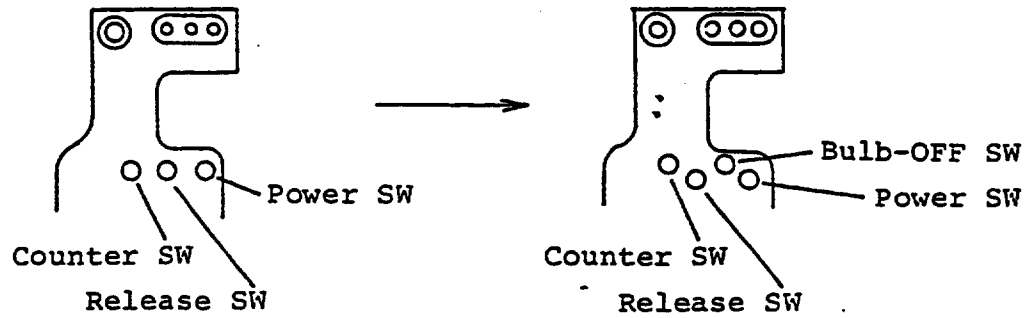
Details of FPC modificationFor service on the camera incorporated with the old FPC

When installing new FPC FA4-1001, attach Insulator #750 in place, remove Circuit board B FA1-1092 and replace Release switch unit FA1-307 with new one.

When installing new Shutter assembly FA3-281, replace FPC FA4-1001 with new one.

Difference between the old shutter release switch and the new one

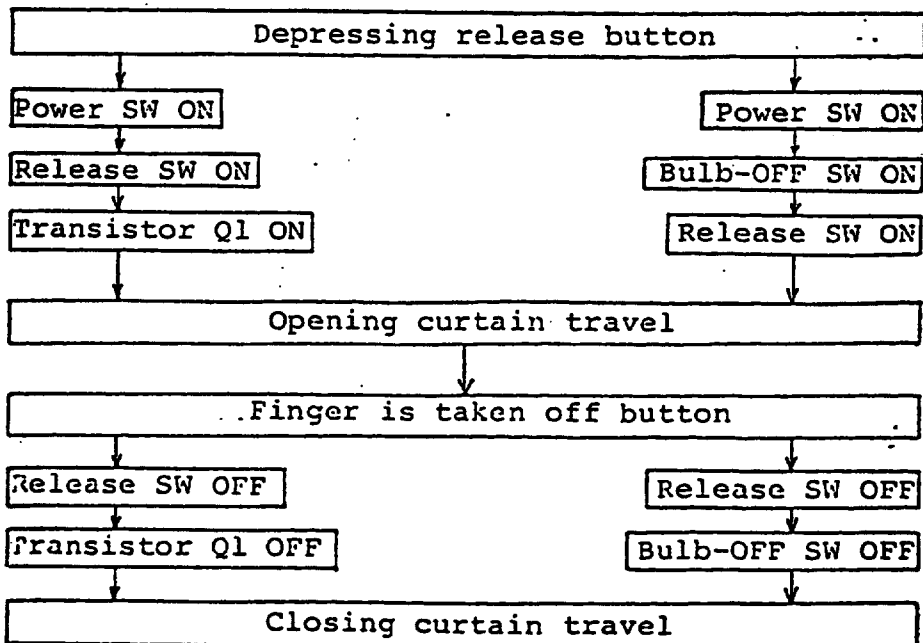
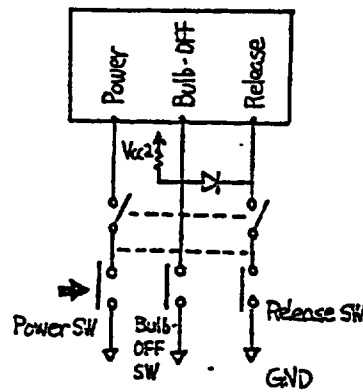
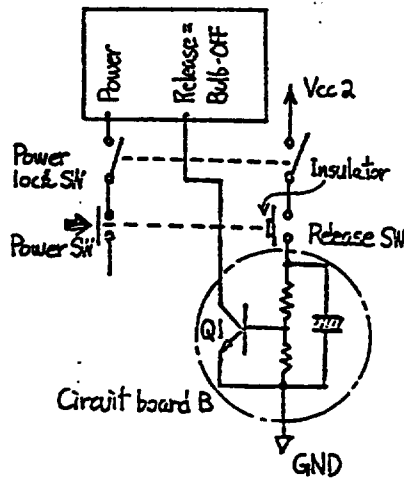
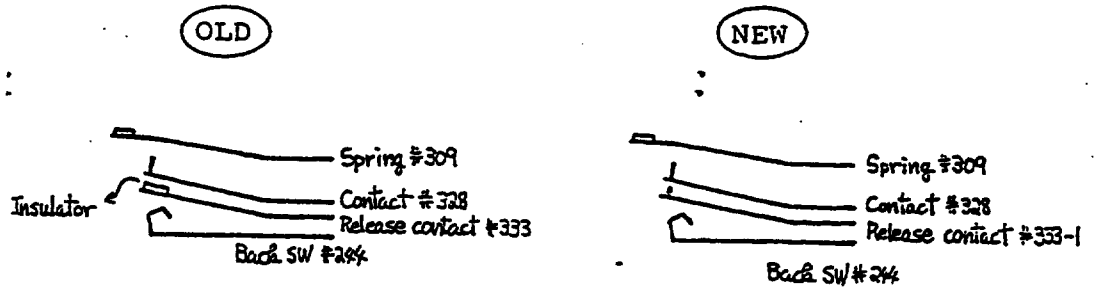

Old shutter release switch: Turning off release switch direct allows closing shutter curtain to travel.

New shutter release switch: Turning off Bulb-OFF switch, as well as release switch, allows closing curtain to travel. Thus Bulb-OFF switch secures Bulb-operation when shutter release button fails to be pressed properly.

Release button stroke

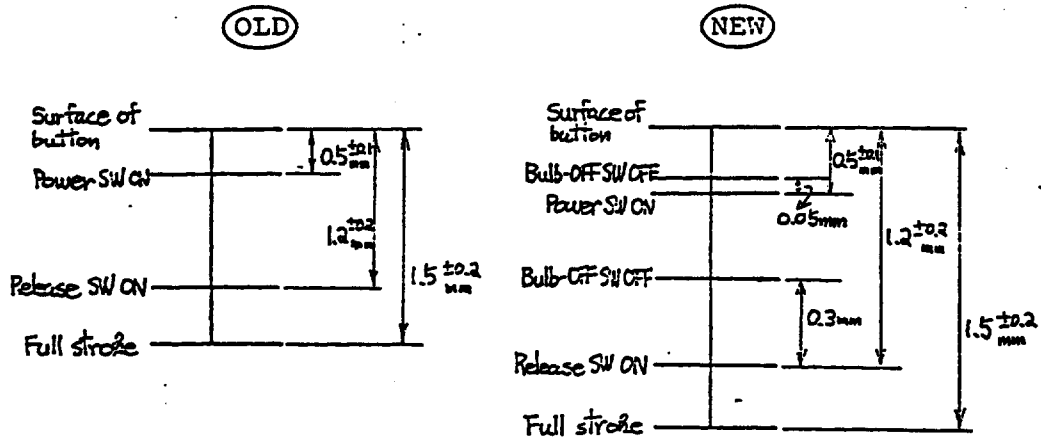

	OLD	NEW
Power SW ON	0.5mm ± 0.1	0.5mm ± 0.1
Bulb-OFF SW OFF		More than -0.3mm from Release SW ON. Less than 0.05mm from Power SW ON
Release SW ON	1.2mm ± 0.2	1.2mm ± 0.2
Full stroke	1.5mm ± 0.2	1.5mm ± 0.2

Note: Bend Retainer #334 or Release contact #333-1 to adjust the Bulb-OFF SW OFF stroke.

**CROSSREFERENCE OF INSTALLING COM-
BINATION OF FPC AND SHUTTER ASSEMBLY**

Technical Information No. F3-800025 has informed that FPC FA4-1001 and Shutter FA3-281 have been modified to improve the Bulb-operation accuracy. Therefore, there have been two types of FPC and three types of shutter assembly since the implementation of this modification in closing curtain switch.

FPC/ Shut- ter Camera body	FPC FA4-1001	Shutter FA3-281	FPC FA4-1001- 1	Shutter FA3-281-1	Shutter FA3-281-2
Type I FA4-1001 FA3-281	OK	OK	Remove FA1-1092 and install FA1-307-1. Attach #750 onto bottom cover.	Replace FA1-307-1 with FA1-307.	Replace FA1-300-1, FA1-307-2, #304-1 and #308-1 with old ones.
Type II FA4-1001-1 FA3-281-1	Not Available	Install FA1-307-1.	OK	OK	OK
Type III FA4-1001-1 FA3-281-2	Not Available	Install FA1-300-1, FA1-307-2, #304-1 and #308-1.	OK	OK	OK

Section 1 Specifications & Mechanism

Content	Page
Figure of External	M1
1-1 Specifications	M2
1-2 Outlines of Mechanism	
1-2-1 Film-advance Mechanism	M5
1-2-2 Counter Switch Mechanism	M6
1-2-3 Closing Curtain Switch & Film-advance Limit Mechanism	M7
1-2-4 Multi-exposure Mechanism	M9
1-2-5 Shutter-release Magnet & Shutter-release Mechanism	M10
1-2-6 Mirror Mechanism	M11
1-2-7 Shutter Switch & Switch Mechanism	M13
1-2-8 Shutter Mechanism	
1-2-8-1 Outline	M14
1-2-8-2 Shutter Cocking Mechanism	M15
1-2-8-3 Shutter-release Mechanism	M17
1-2-8-4 Mechanical Shutter Release by the Shutter-release Knob	M20
1-2-8-5 Time Operation for Extra-long Exposure	M21

外觀圖 Figure of External

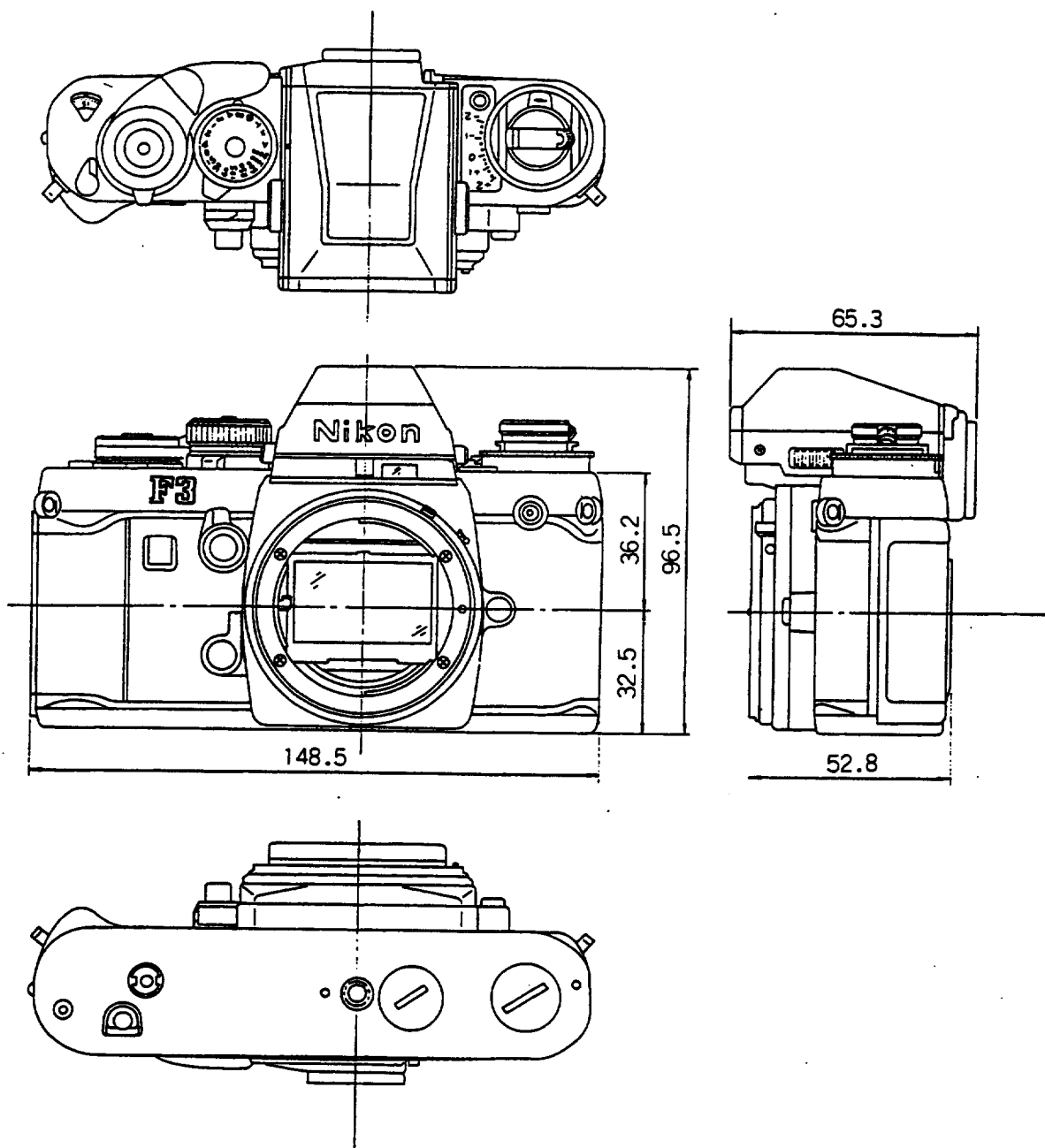

1-1 Specification

Type: 35mm single lens reflex camera

Picture format: 24mm x 36mm

Viewing system: Frame coverage; 100%
Interchangeable viewfinders

Lenses usable: AI-type Nikkor lenses and Non AI-type
Nikkor lenses (Stop-down exposure metering)

Lens mount: Nikon bayonet type

Shutter: Electromagnetic shutter-release;
electronically controlled, horizontal-travel
titanium focal-plane shutter; automatic
shutter speed selection within a range of
8 sec. to 1/2000 sec.; manual shutter speed
selection for the 8 - 1/2000 sec. range
plus "B" (electronic), "T" (mechanical)
and X synchro (1/80 sec.); when power
source is exhausted, exposures can be
made at 1/60 sec.
Via mechanical-release knob (11.5ms)

Self-timer: Electronically controlled; Red LED flickers
to indicate its operation (10 sec.)

Exposure measurement: TTL center-weighted exposure metering at
full aperture; body-built-in meter
incorporates one silicon photo-diode (SPD);
metering range EV1 to EV18

ASA film speed range: ASA12 - 6400

Exposure compensation: +2EV to -2EV
(At ASA12, up to EV+1, at ASA6400, down
to EV-1)

Memory lock: Provided

Viewfinder information: Liquid crystal display;

- 1) Shutter speed ... four-digit read-out
- 2) Under/overexposure (manual) ...
"+" and "-" display
- 3) Beyond auto exposure control ...
"+2000", or "-8-" display
- 4) Manual shutter speed setting ...
"M" display

Red LED display

At flash shooting, ready-light lights up when flash unit is charged and flickers when the setting is beyond camera's synch range or mounting foot is insufficiently installed or ASA dial is set at a film speed higher than 400.

Aperture-direct-readout provision

enables indication of lens aperture set when lens in use offers AI facility.

Built-in illuminator

illuminates LCD and ADR.

Focusing screen:	Interchangeable, exclusively-designed (F2's screen not usable)
Film advance lever:	Single stroke or a series of strokes; stand-off angle 30°, winding angle 140°
Frame counter:	Shows number of frames exposed; automatically resets to "S" when camera back is opened; automatic operation starts from frame 1.
Multi-exposure:	Possible via multi-exposure lever
Film rewinding	Manual crank-type
Flash synchronization:	Synchronization range; for electronic flash unit, 1/80 sec. to 8 sec. plu "B" synch speed when optional electronic flash unit is mounted; Auto..... 1/80 sec. Manual... 1/80 sec. (X or faster) Set shutter speed (slower than X)
Accessory Shoe:	fitted with hot-shoe contact, ready-light contact and TTL auto flash signal contact.
Reflex mirror:	Automatic instant-return mirror with lock-up feature
Depth-of-field preview button:	Provided
Camera back:	Hinged, swing-open type; removable; memo-holder provided

Motor-drive coupling: Screw-on type connection
Signal 1) Closing curtain signal
2) Electromagnetic shutter-release start signal
3) Film-advance completion signal
4) Power source signal
5) 16 sec.-hold signal
6) Release-metering signal

Cable release socket: Tapered screw

Meter ON/OFF switch: Meter switched on when shutter release button is depressed slightly; stays switched on for 16 sec. after finger is lifted off button: Display also stays indicated for 16 sec. after switching off.

Power source: Two 1.5V silver-oxide batteries (G13); powered by MD's power source when mounted MD.

Battery power check: can be made by LCD (power is enough while display remains indicated).

Dimensions: 148.5 (W) x 96.5 (H) x 65.5 (D) mm

Weight: 700g

1-2 Outlines of Mechanism

1-2-1 Film-advance Mechanism

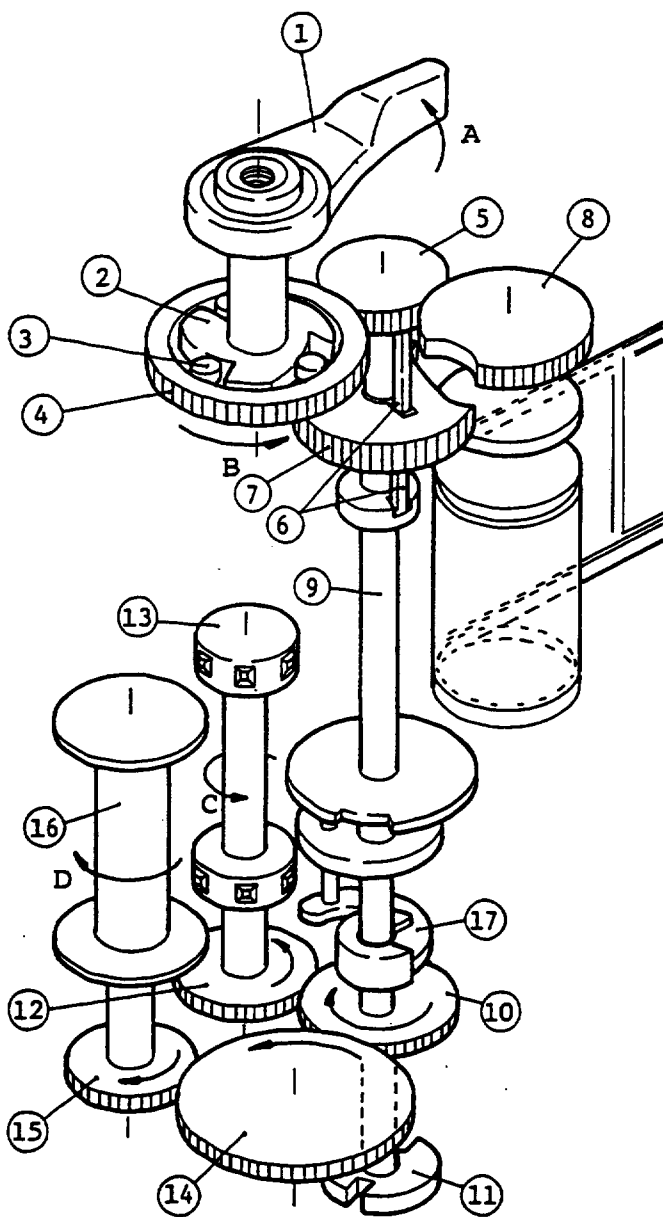

The film-advance mechanism of the F3 is characterized by the one-way clutch and the connecting shaft: the former serves for noise reduction, as well as series of shorter film-advancings, the latter simplifies the drive gears train or decreases the torque which the motor-drive needs to fulfil film-advancing.

MD take-up torque:

F3 ... 1.0kgcm

F2 ... 3 - 5.5 kgcm

Stroking Film-advance lever ① in the direction A rotates Take-up Gear ④ in the direction B by way of Clutch ② and Roller ③ (One-way clutch). This power rotates Gears ⑤ and ⑦, and reaches Gear ⑩ through the connecting shaft.

Gear ⑦ (Incomplete gear) rotates Gear ⑧ to cock the shutter. But Gear ⑩ drives Sprocket Gear ⑫, Spool Idle Gear ⑭ and Spool Gear ⑮ to rotate Sprocket ⑬ and Spool ⑯ in the respective directions C and D.

Note: Shutter cocking and Take-up Claw ⑰ are referred to Multi-exposure mechanism, page (M9) and Shutter cocking mechanism, page (M15) respectively.

1-2-2 Counter Switch Mechanism

After loading the film into the camera, it is necessary to make a few blank exposures for taking the first picture.

However, as to automatically controlled camera, if the shutter-speed dial is set to "Auto", shutter speed becomes slow under low-light conditions, which prevents rapid picture-taking action.

For quick and easy film loading, auto-exposure control remains cancelled until the frame counter reaches "1" as is already introduced by the EM.

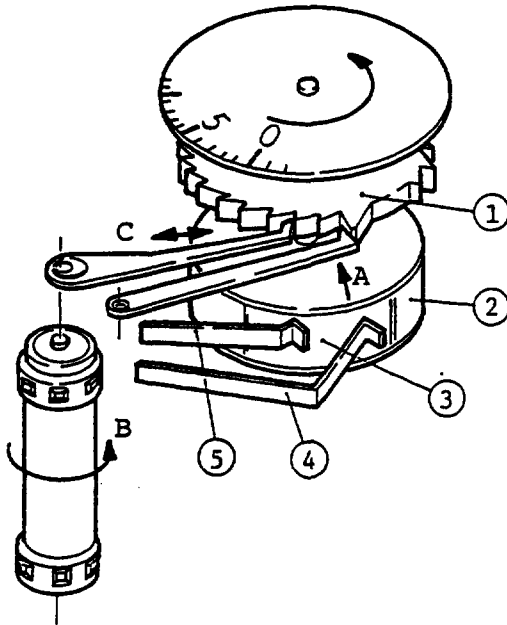

The mechanism is: When the frame counter is advanced by the film-advance operation, ON/OFF changeover of the counter switch is made by the combined operation of Ratchet (1), Insulator (2), Conductor (3), Contact Blade B (4) and Contact Blade A (5).

With the shutter-speed dial set to "Auto", when the frame counter is between "S" and "0", the shutter speed becomes automatically 1/80 sec. by the operation of IC circuit.

At shutter-speed dial settings ranged from 1/2000 - 1/125 sec., the shutter speed also becomes 1/80 sec.

Counter switch turns OFF while the frame counter indication is between "0" and "1". Auto-exposure control starts working after the frame counter reaches "1".

1-2-3 Closing Curtain Switch & Film-advance Limit Mechanism

A Closing curtain switch for the F3 opens during film-advance operation and closes at shutter-releasing, which gives film-advance signal to the motor drive.

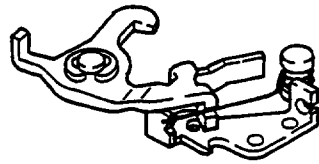

Closing Curtain SW

During film-advancing:

B When Connecting Shaft is rotated, Stopper ① rotates in the direction A and the claw of ① pushes Take-up Stopper ② in the direction B, turning closing curtain switch OFF.

End of film-advancing:

C When film-advance operation is complete, the roller of Charge Lever ③ is pushed in the direction C by Cam ④. As a result, Stopper Lever ⑤ which held by ③ moves in the direction D and engages with ②, thus retaining ②. Film-advancing is limited by the engagement between the claw of ① and ②. In accordance with the movement of ②, Stopper Lever ⑥ moves in the direction E until the tip of ⑥ comes in contact with Stopper ⑦, thereby stopping the rotation of the sprocket.

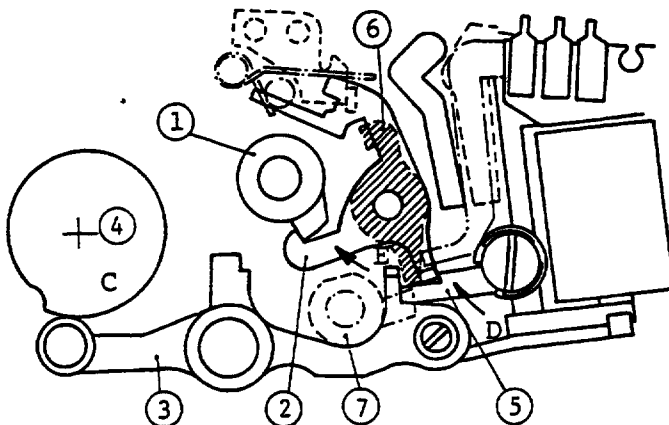
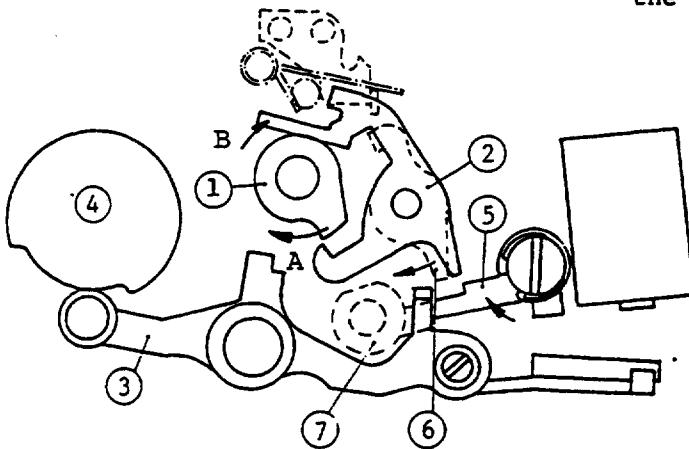

Shutter-releasing :

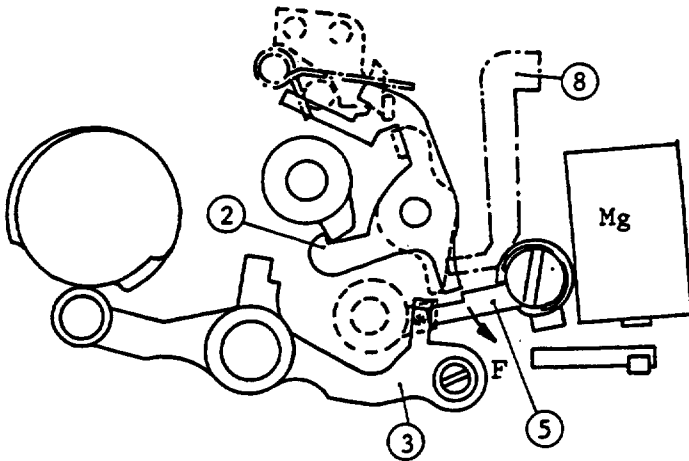

- D When the shutter-release button is depressed, Spring ⑧ is pushed and holds ②. When the closing curtain is released, ③ falls apart from the magnet and the protrusion of ③ (mark※) strikes ⑤ in the direction F.

Completion of Release :

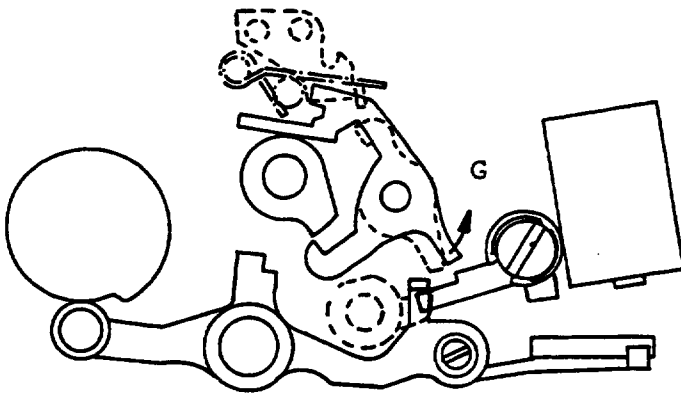

- E When the finger is lifted off the release button, ② is rotated in the direction G by Spring force and ② is disengaged from ①. Then, closing curtain Switch becomes ON and film-advance signal is given to the motor drive to start.

Troubleshooting

- I) With the motor drive mounted, if closing curtain switch closes earlier than the time when ① is disengaged from ②, the motor drive fails to operate by the operation of film-advance auto-stop circuit.
- II) When the shutter is released with the pressure applied onto the film-advance lever, if the spring (#309) is not effectively tensioned, the blurred image may result.

1-2-4 Multi-exposure Mechanism

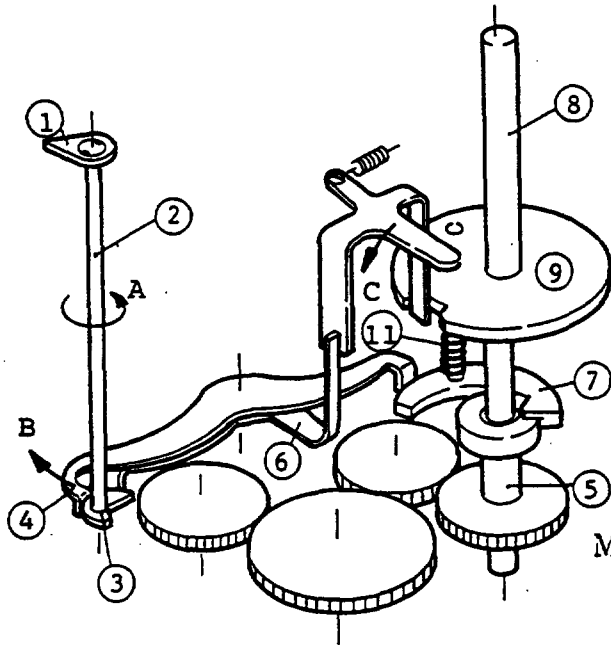

Multi-exposure mechanism of the Nikon F3 is different from that of the Nikon F2. To facilitate the multi-exposure control, Multi-exposure Lever ① is located on the top of camera body.

Multi-exposure Setting :

When Multi-exposure lever ① is set to multi-exposure control setting, both Axle ② and Cam ③ are rotated in the direction A and thus Cam rotates Set lever ④ in the direction B. At this moment, Take-up claw ③ is disengaged from the cutout of Lower gear ⑤. Simultaneously, Cam ③ is held by Lock lever ⑥.

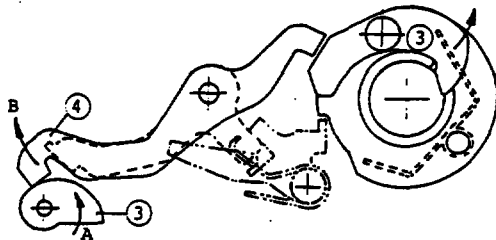

Winding Operation :

When the film-advance lever is stroked with Multi-exposure lever set to multi-exposure control setting, ⑦ is disengaged from the cutout of ⑤. Since the rotation of Connecting shaft ⑧ is not transmitted to ⑤, neither Sprocket nor Spool rotates. However, the shutter is cocked, because Incomplete gear incorporated into ⑧ engages with Shutter curtain control gear.

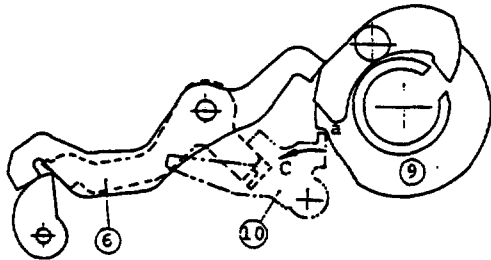

Cancellation :

During film-advance operation cycle, when Take-up disk ⑨ rotates from Point a to Point b, Signal lever ⑩ is pushed in the direction C and thus ③ is disengaged from ④. At the end of film-advance operation (i.e. immediately when ⑩ engages with Portion a of ⑨), ⑦ is engaged with the cutout of ⑤ by Spring ⑪, thereby restoring to the normal condition.

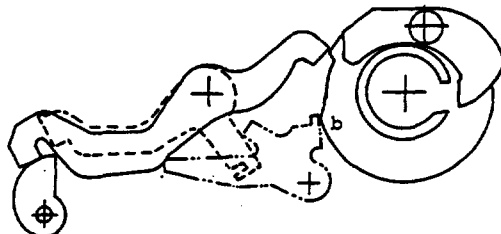

Note: During film-advance operation, ⑤ is not disengaged from ⑥, thus preventing multi-exposure operation.

1-2-5 Shutter-release Magnet & Shutter-release Mechanism

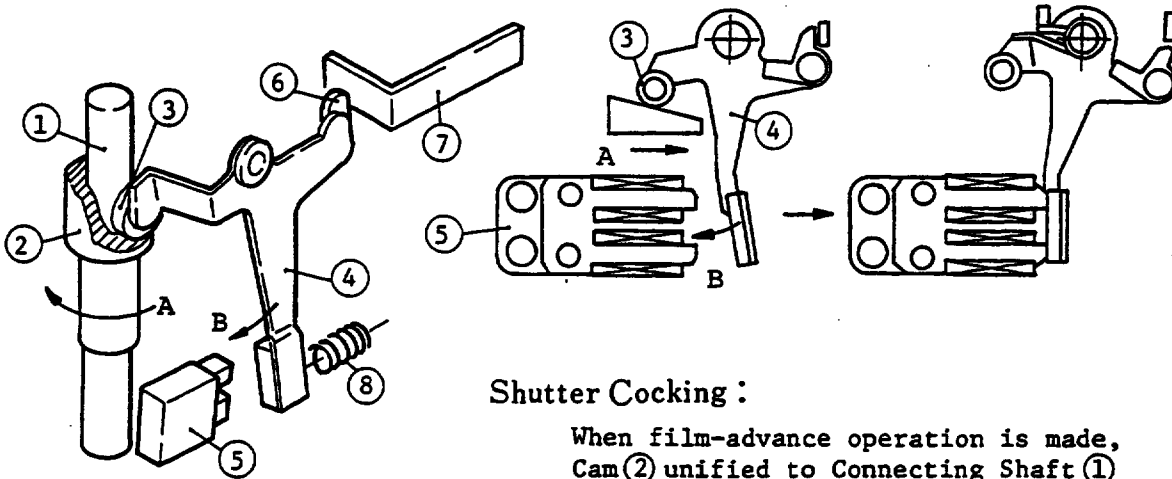

Shutter Cocking :

When film-advance operation is made, Cam ② unified to Connecting Shaft ① rotates in the direction A. As a result, Roller ③ on the cam surface (shaded area) is pushed up and Lever ④ moves in the direction B, then sticks to shutter-release Magnet ⑤, resulting in shutter-cocked condition.

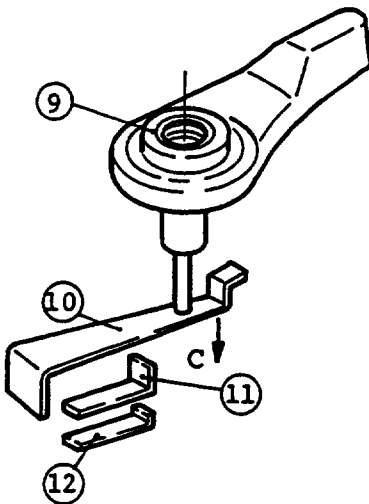

Troubleshooting

Shutter cannot be completely cocked if the shutter-release magnet unit is incorrectly installed.

Shutter-releasing :

When Shutter-release Button ⑨ is slightly depressed, Lever ⑩ is pushed downward (Arrow C) and comes in contact with Blade ⑪, closing release-metering switch. Thus power source circuit becomes ON and display system starts operating.

When the button ⑨ is depressed further down, both ⑩ and ⑪ touch Blade ⑫, closing the release switch.

Simultaneously, release-signal is given to the magnet and the magnet loses the magnetic force.

Therefore, ⑥ being tensioned by Spring ⑧ is drawn in the direction D and Claw ⑥ pushes Lever ⑦ upward (Arrow E) to release the reflex-mirror, thus releasing the shutter.

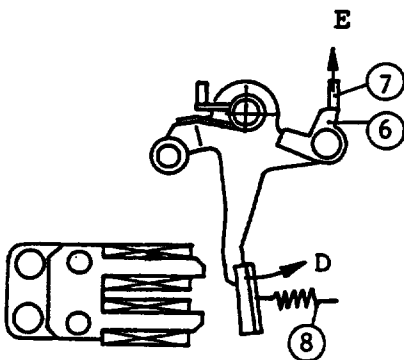

1-2-6 Mirror Mechanism

Front unit assembly consists of two units: front plate unit and mirror box unit, which have been divided so far in the earlier models.

The main components are:

- 1) Mirror-box (Mirror-actuator and Mirror holder)
- 2) AI meter coupling
- 3) Electromagnetic-release
- 4) Lens manual stop-down and Mirror lock-up
- 5) Mechanical shutter-release
- 6) Switches (Shutter SW, Safety SW and Memory SW)
- 7) Viewfinder
- 8) Electrical control system

The main features are:

- 1) Specially treated reflex-mirror and Metering system

Almost all light coming through the lens is led into the viewfinder via the reflex-mirror as usual. However, a small percentage of light will pass through the pinholes half-mirror located in the middle of the reflex-mirror (See fig.) to lead the light to the light sensor via the metering mirror for exposure metering.

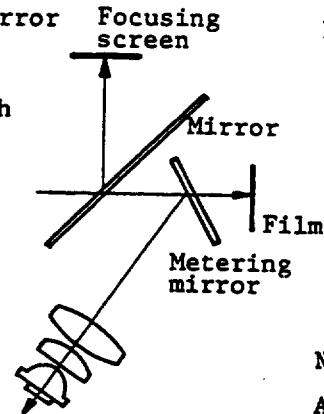

Shaded area:

Pinholes half-mirror
Transmission = 8%
Pinhole shape = oval

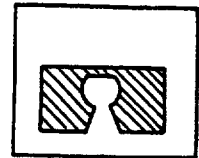

Number of pinholes =
Approx. 17,000/cm²



- 2) Air damper system

Air damper is incorporated in the mirror-actuating unit to decrease mirror shock and to muffle the sound.

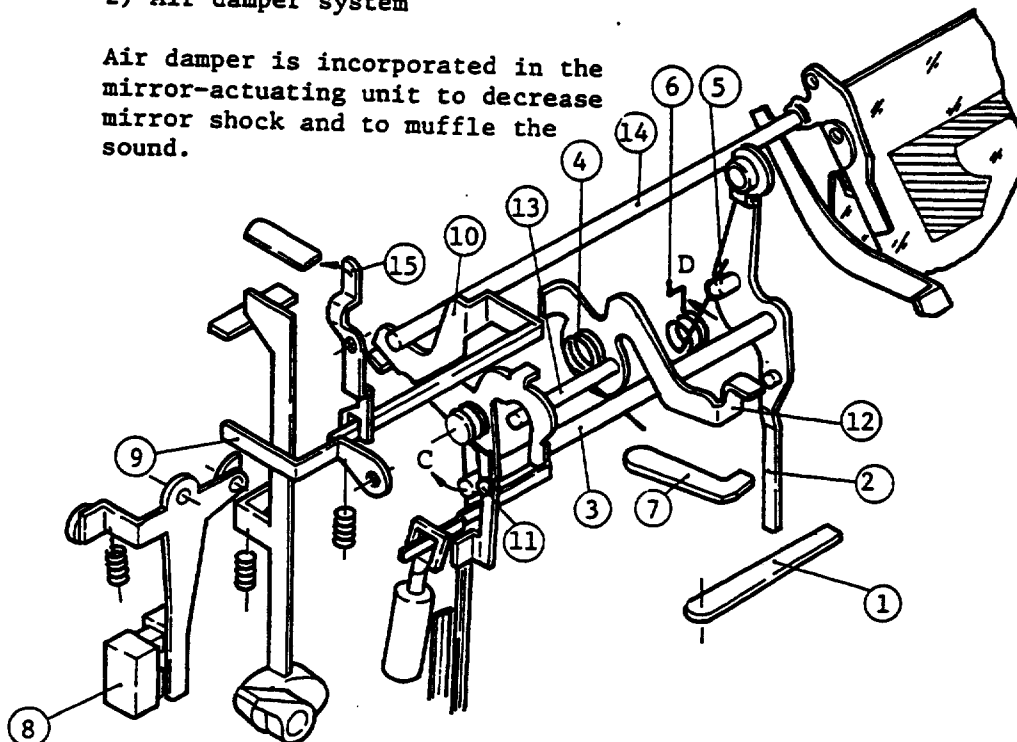

Mirror-cocking Mechanism

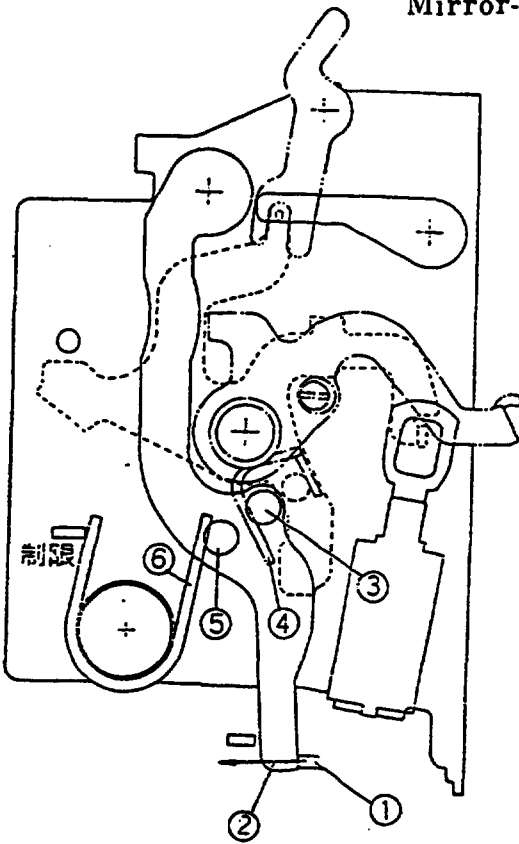

Mirror-cocking :

While the film-advance lever is stroked, Mirror Cocking Lever ① pushes Vertical Lever ② via Mirror-charge Cam in the direction A. Pin ⑤ on ② also charges Spring ③ as soon as Pin ⑤ charges Mirror-down Spring ⑥. When the film-advance lever is further stroked, ② is engaged with Quick Return Lever ⑦, thus completing mirror-cocking. Under the condition, ① returns to its original position.

Mirror-releasing :

When the shutter-release button is fully depressed, Lever ⑨ is pushed upward (Arrow B) and disengages Main Lever ⑩. At the moment, Mirror-up Spring ④ engaged with Pin ⑪ on Lever ⑩ is released and rotates Lever ⑩ in the direction C. When ⑩ rotates, Lever ⑫ is pushed in the direction D via Pin ⑬ and the mirror is raised up (Arrow E) via Pin ⑭. While the mirror is rising to the taking position (Interval between the mirror and the mirror-stopper to be $8.3 \pm 1\text{mm}$), the shutter is released via Lever ⑮ engaged with Lever ⑩. After completion of closing curtain's travel, ⑦ is disengaged from ② and ② is returned to its original position by Mirror-down Spring ⑥. Other associated levers are also returned to its original position.

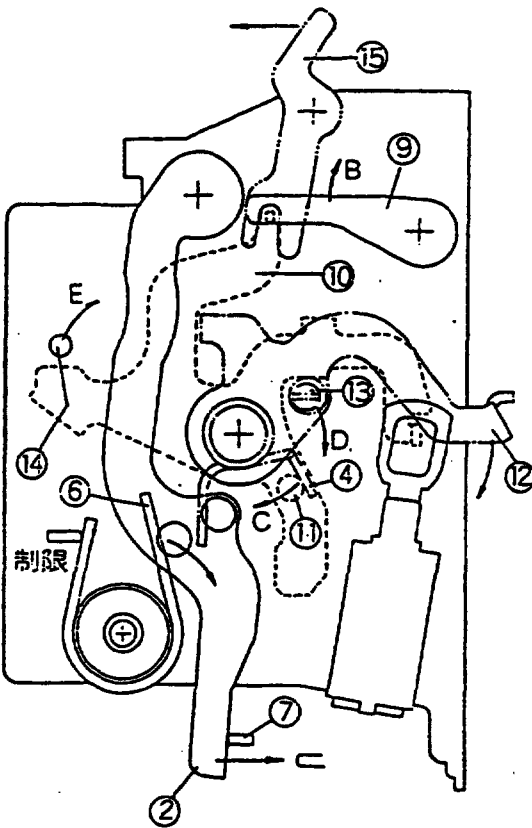

Troubleshooting

Main causes of failure to advance the film when the film-advance lever is stroked with a lens mounted may be traced to the following:

- Incorrect height of Diaphragm Actuating Lever ⑫
- Improper engagement between Lever ⑨ and Main Lever ⑩
- Improper movement of Main Lever ⑩ due to unbalanced power of every spring.

1-2-7 Shutter Switch & Mechanism

These switches closes when Main Lever ⑩ starts moving and opens at mirror-down.

Note: With the F3, Mirror Switch for memory which has been incorporated into the electronically controlled camera (EL, FE, etc.) is not provided. Instead, memory is done by the combination of the analogue actuating signal and the OFF/ON timing of shutter switch, thereby enhancing the reliability.

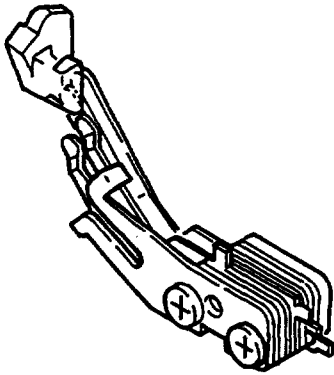

Shutter SW

Troubleshooting

Should chattering of shutter switch occur, unstable auto-shutter speed may result.

Metering Mirror :

Metering mirror moves in strict accordance with the movement of the reflex-mirror and sticks to the mirror-holder at up-position.

Thus, image cut-off by metering mirror will not occur.

1-2-8 Shutter Mechanism

1-2-8-1 Outlines

The F3 uses a conventional double-roller focal plane shutter, whose curtains are made of titanium. Shutter-speed control is electrical at the automatic/manual setting from Bulb to 1/2000 sec. But it is purely mechanical at the manual setting of 1/2000 sec. and Time (extra-long exposure) operation. Additionally, the second shutter release button is provided for the mechanical release at a speed of 1/55 sec. when the battery's power is exhausted.

All parts of the shutter mechanism are installed into a complete unit. The unit can be removed alone from the camera body and directly brought under repairs and adjustments.

The performance of the mechanism is assured by the following characters:

- 1) Cocking the shutter by the incomplete gear separates the shutter mechanism from the film-advance mechanism at the completion of shutter cocking cycle. Thus, the shutter curtains travel does not shock the film-advance mechanism.
- 2) The time of the shutter curtains travel across the aperture is decelerated to approx. 12ms (the F2 is specified as approx. 10ms). It has the advantage of stabilizing the travel at higher shutter-speed release, improving the durability of curtains and reducing the torque of film-advance.
- 3) The shutter control mechanism provides a stable start-timing of shutter curtains travel at the setting of 1/2000 sec.

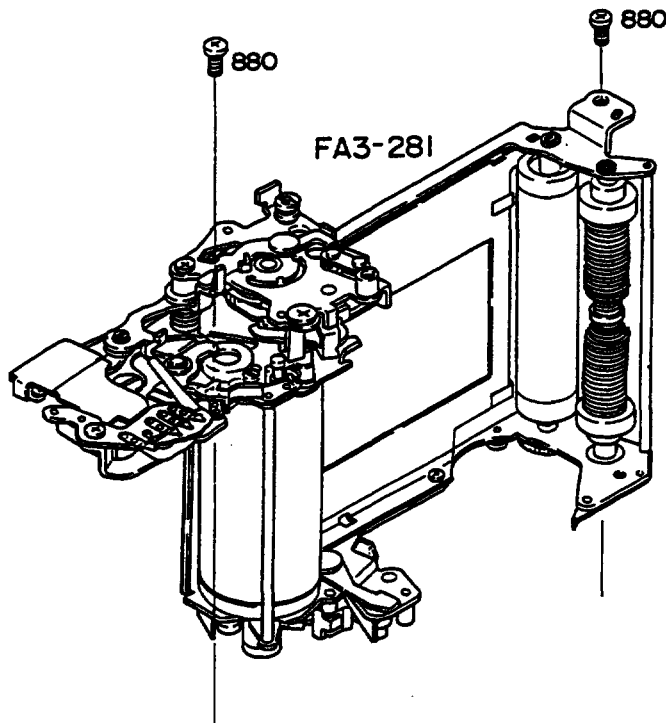

1-2-8-2 Shutter Cocking Mechanism

Stroking the film-advance lever rotates Gear ①, Gear ② and Gear ③ (incomplete Gear). Gear ② disengages Claw ⑤ (bound-proof claw) from the cam on Gear ⑥. Thus, Gear ⑥ allows Cam ⑦ to rotate in the direction A. Cam ⑦ drives Cam ⑧ and Pulley ⑪ through the engagement of Post ⑦-1 with Protrusion ⑧-1. Turning Pulley ⑪ engages with Post ⑫ to start the winding rollers of opening and closing curtains.

Simultaneously, the motion of Cam ⑦ pushes Arm ⑨ in the direction B, and spring-loaded Hook ⑭ follows Arm ⑨ until its end attaches onto Magnet ⑮. Note also that the motion of the cam on Gear ⑥ closes the trigger switch.

At the final stage, Gear ③ is disengaged from Gear ⑥ by the incomplete teeth of each gear so as to cut off the film-advance mech. from the shutter release shock. Lever ⑯ engages with Cam ⑦ for the shutter control. Claw ⑰ latches Cam ⑧ for tensioning the opening curtain. Post ⑫ holds Hook ⑭ for tensioning the closing curtain. Thus, the shutter cocking procedure is completed.

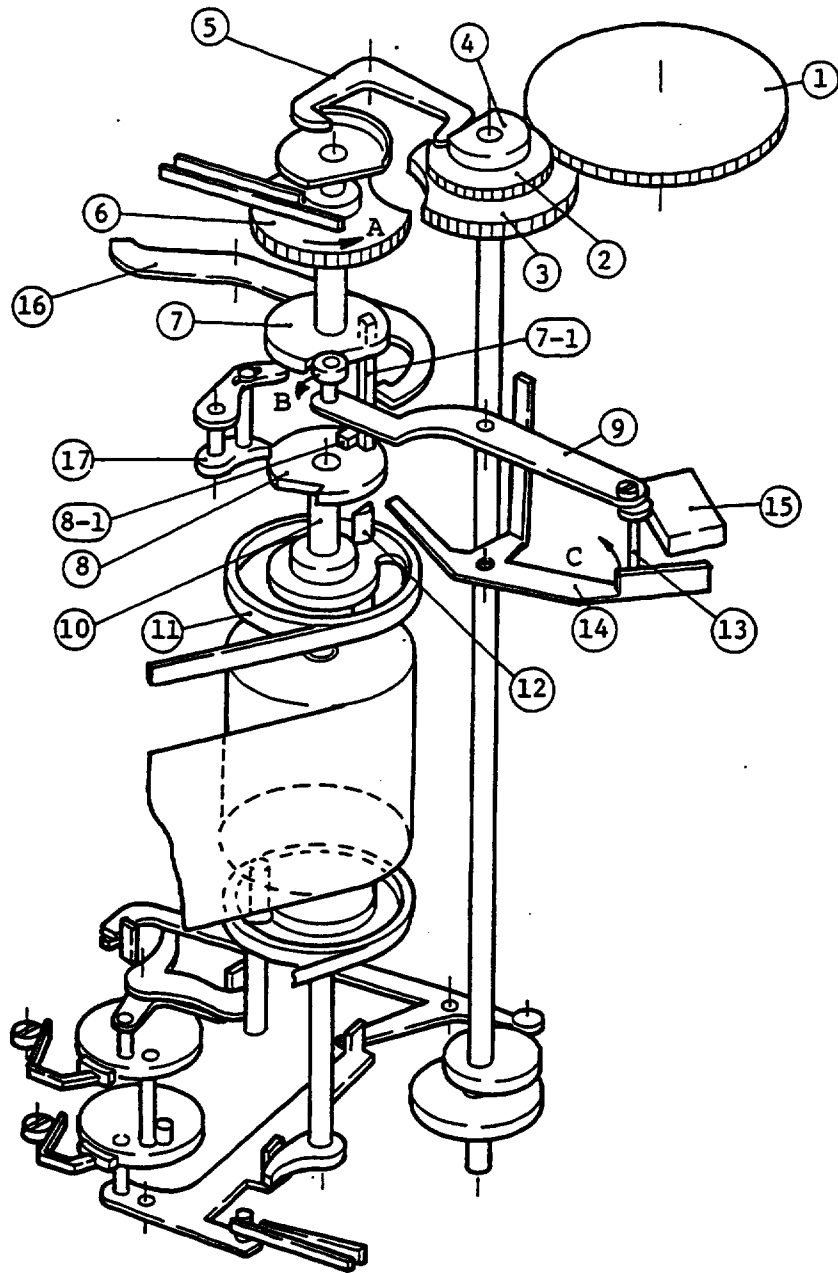

1-2-8-3 Shutter-release Mechanism

At the Automatic/Manual Setting from Bulb to 1/2000

Depressing the shutter-release button raises the mirror to the taking position through use of the electrical signal. After the mirror rising, the signal lever (see page) disengages Lever (16) from Cam (7). Thus, Cam (7) and Gear (6) rotates in the direction D.

Gear (6) opens the trigger switch, and the shutter control circuit will be in operation. It changes Magnet (15) to hold Hook (14) with its magnetic force.

Post (7-3) of Cam (7) strikes Lever (18), and Lever (17) unlatches Cam (8). So the opening curtain starts to travel across the aperture.

After the shutter speed is determined, the control circuit cuts off the current flow to Magnet (15). Magnet (15) frees Hook (14), and Hook (14) is disengaged from Post (12). It releases the closing curtain.

To return the mirror to the viewing position, Pin (21) strikes Lever (22).

Note that when the opening curtain is released, Lever (19) closes the syuch contact through Arm (20).

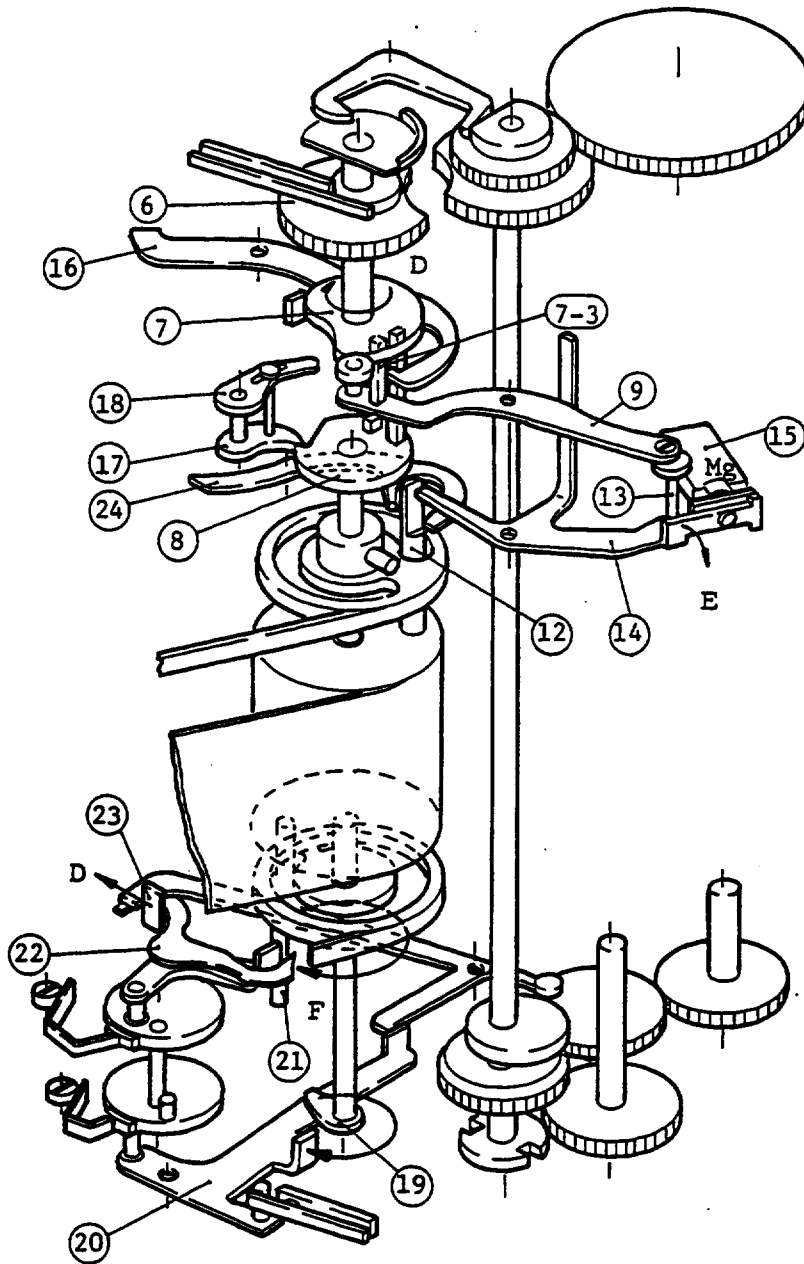

At the Manual Setting of 1/2000 sec.

The mechanism operates in the same procedure as at the automatic/manual setting from Bulb to 1/2000 sec. until the opening curtain starts.

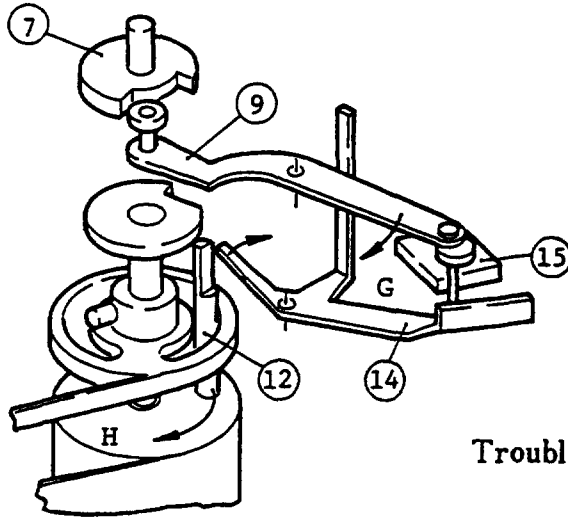

At the manual setting of 1/2000 sec. the shutter control circuit does not charge Magnet (15). Thus it does not hold Hook (14). The motion of Cam (7) returns Arm (9) to the original position. Hook (14) follows Arm (9), and disengages Post (12). The closing curtain travels across the aperture.

Troubleshooting

Time variations of the shutter curtain-travel fall into two categories at the manual setting of 1/2000 sec. When the variations are less than 0.05ms, they should be troubleshooted to the shutter control components; the movement of Hook (14), the rotation of Cam (7) and loosened Eccentric pin #283. When the variations are more than 0.05ms, they should be troubleshooted to the shutter components; the shutter curtain position, the rotation of the winding/take-up rollers, the defective springs for tensioning curtains, the excessive play of Drum Shaft and deformed light-shield #255.

When the exposure information displays +2000 for shutter speed at the automatic setting, the mechanical limiter can work to release the shutter at min. speed of 0.35ms.

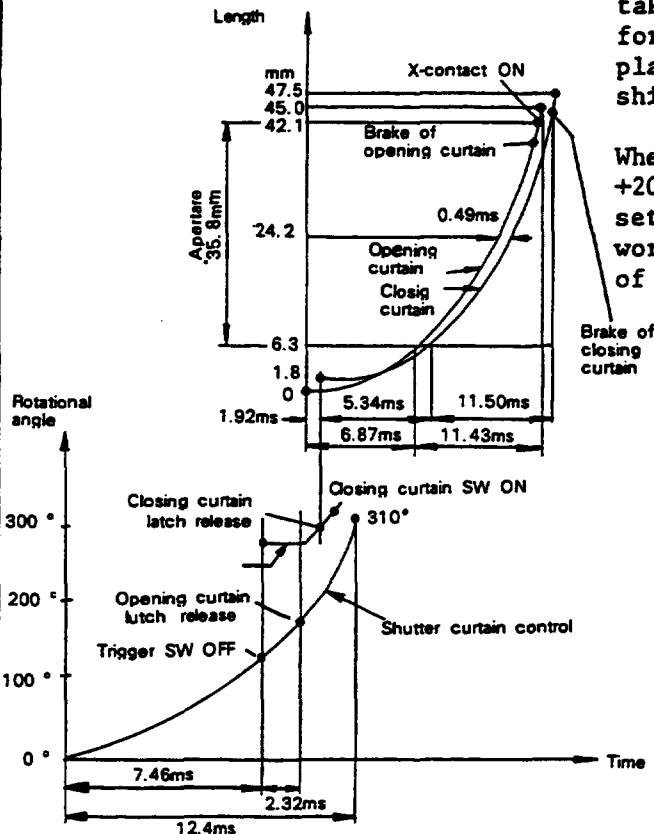

1-2-8-4 Mechanical Shutter Release by the Shutter-release Knob

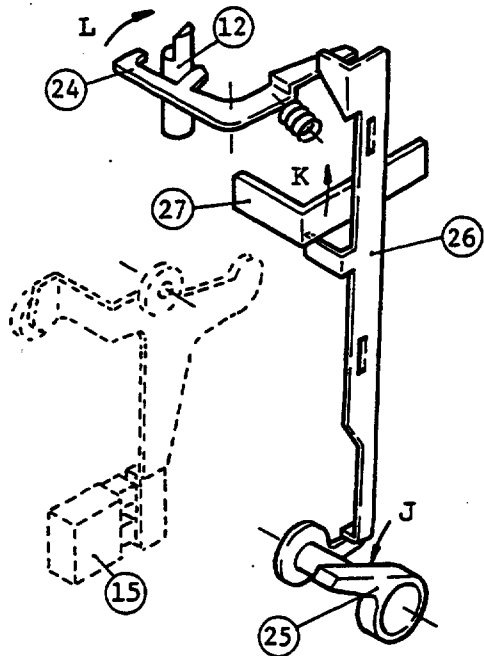

Depressing Knob (25) pushes Hook (26) upward as illustrated. This releases the mirror by Lever (27). Simultaneously, Hook (26) disengages Lever (24) from Post (12). As to subsequent mechanical operation to the opening curtain's travel, the mechanism works in the same procedure as at the automatic setting.

After completing the opening curtain's travel, Screw (28) strikes Lever (24) to be disengaged from Post (12). This starts the closing curtain. At the time, Magnet (15) does not hold Hook (14). Thus it frees Post (12) when Arm (9) returns after the motion of Cam (7).

Troubleshooting

When the mechanical release is used at the halfway film-advancing, it results in the mirror lock-up or the uneven frame-to-frame spacing.

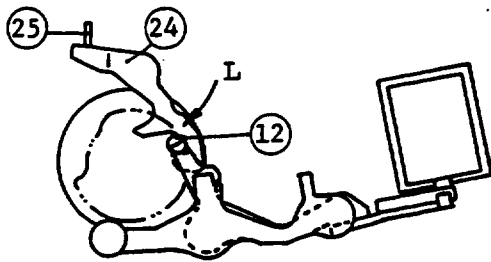

fig. I

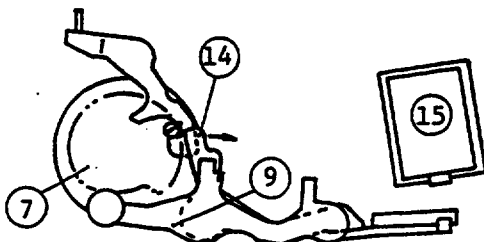

fig. II

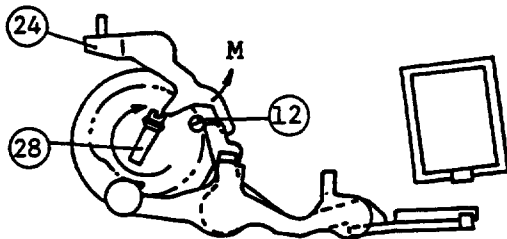
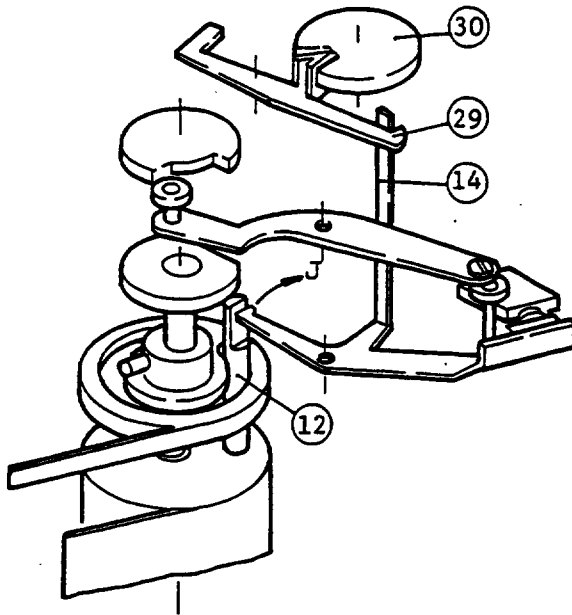

fig. III

1-2-8-5 Time Operation for Extra-long Exposure



Setting the shutter-speed dial to "T" places Lever 29 against Cam 30 as in fig. I, and engages the end of Lever 29 with Hook 14. Mechanical sequence from shutter-release operation to the opening curtain travel is exactly the same as at the manual setting of 1/2000 sec. However, the closing curtain does not travel immediately after the opening curtain, since the engagement of Lever 29 and Hook 14 holds the shutter open for the time-operation.

When the shutter-speed dial is set to "B" or "X" to terminate the time-operation, Cam rotates to disengage 29 from Hook 14. Subsequently, the closing curtain starts.

Troubleshooting

Malfunction of the time-operation is caused by the improper movement of Lever 29 and the insufficient engagement between Lever 29 and Hook 14.

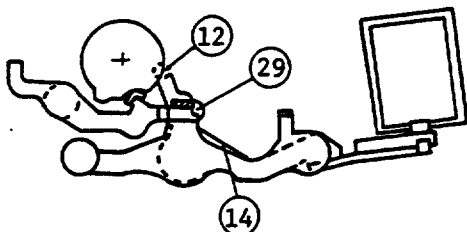

fig. I

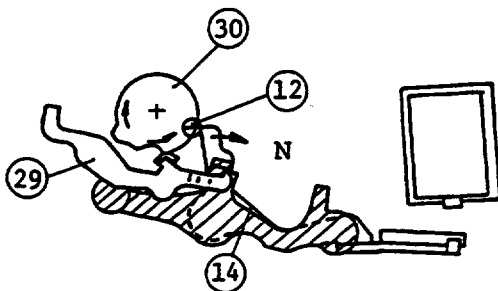

fig. II



Section 2 Disassembling

Content

2-1 Chart of Disassembling Procedure	D1
2-2 Film-advance Lever	D2
2-3 Rewind Crank	D3
2-4 Top cover, rewind side	D4
2-5 Display Block	D5
2-6 Bottom Cover	D6
2-7 FPC (Unsoldering)	D7
2-8 Rewind Lever	D8
2-9 Spool	D8
2-10 Film-advance Signal Unit/Multi-exposure Axle	D9
2-11 Front Plate (Unsoldering)	D10
2-12 Front Plate Assembly	D11
2-13 Combination Magnet	D12
2-14 Shutter Switch	D12
2-15 Mechanical Release Lever	D12
2-16 Mirror Holder	D13
2-17 Mirror Box Unit, rewind side	D13
2-18 FPC Holder	D14
2-19 Take-up Gear Unit	D14
2-20 Shutter Speed Selector	D15
2-21 Sprocket	D15
2-22 FPC (Unsoldering)	D16
2-23 FPC	D17
2-24 Incomplete Gear	D18
2-25 Connecting Shaft/Shutter Unit	D19

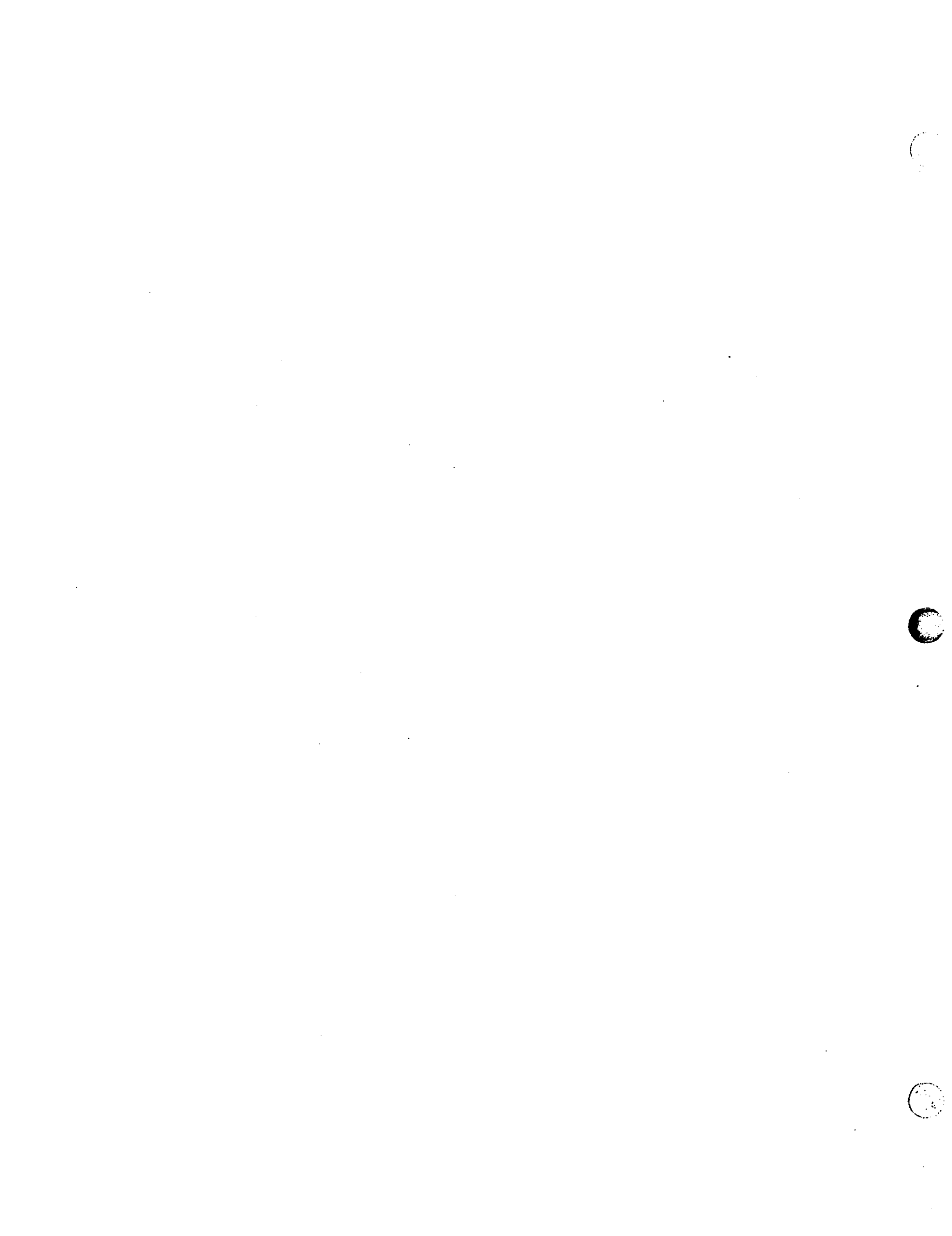

2-1 Chart of Disassembling Procedure

40FB-R.3040.A

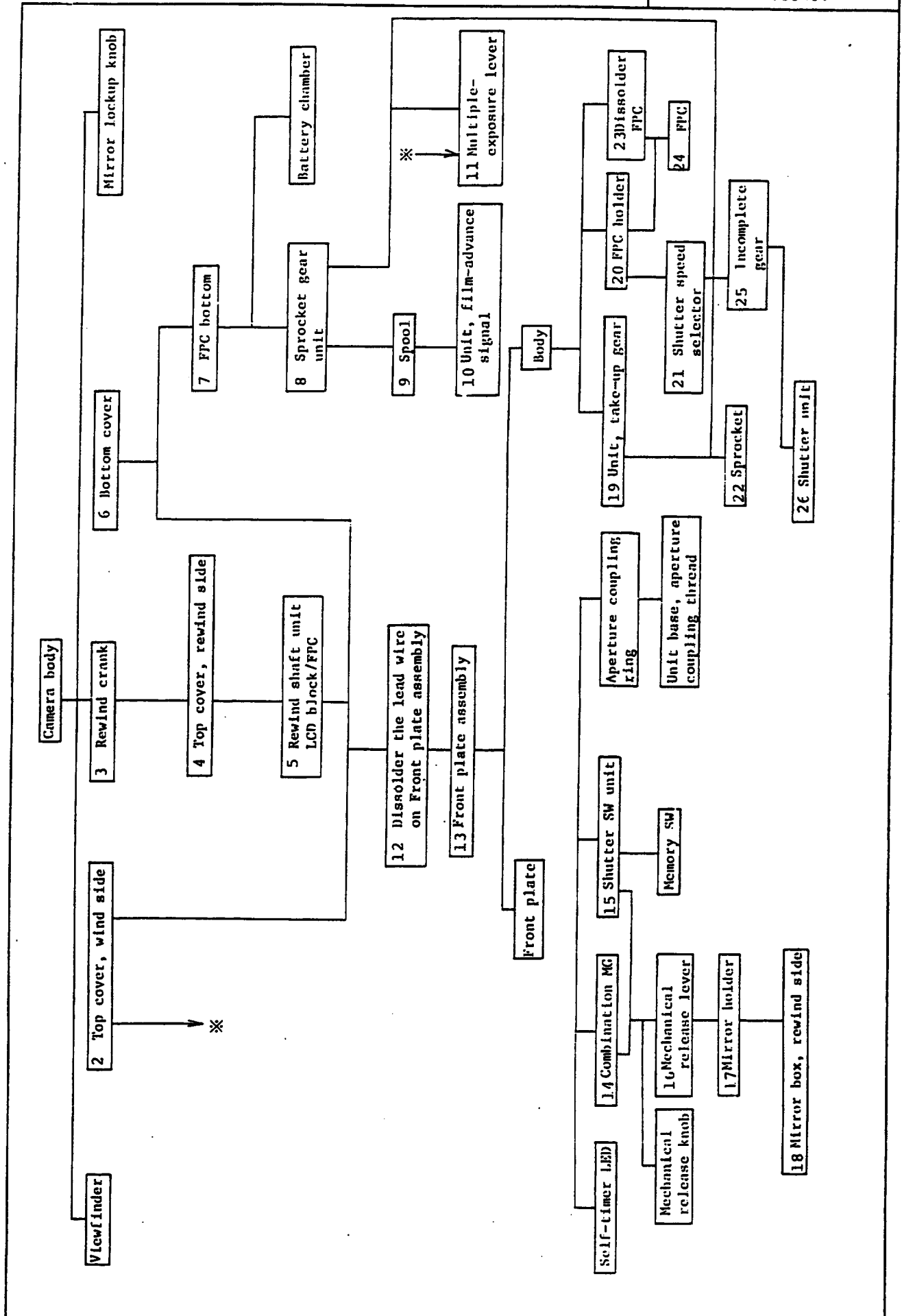

2-2 Film-advance Lever

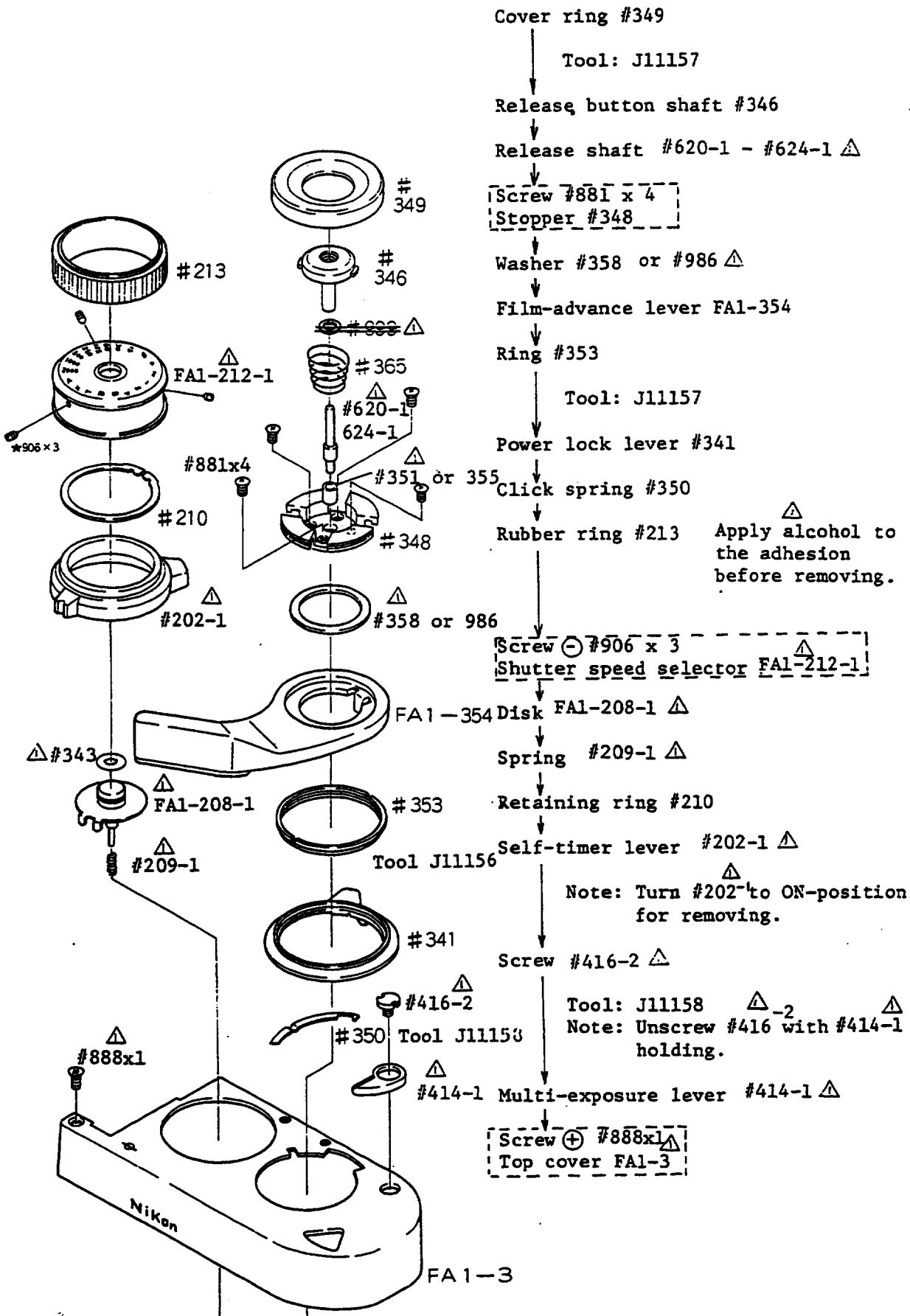

2.3 Rewind Crank

Rewind knob #651-1 Δ
 Rewind crank FA1-652
 Rod #655

Spring #656-1 Δ
~~Washer #658~~ Δ Screw #883x2 Δ

Rewind shaft #659
 Washer #991
 Friction spring #662
 Washer #997 Δ
 Tube, rewind shaft
 #663

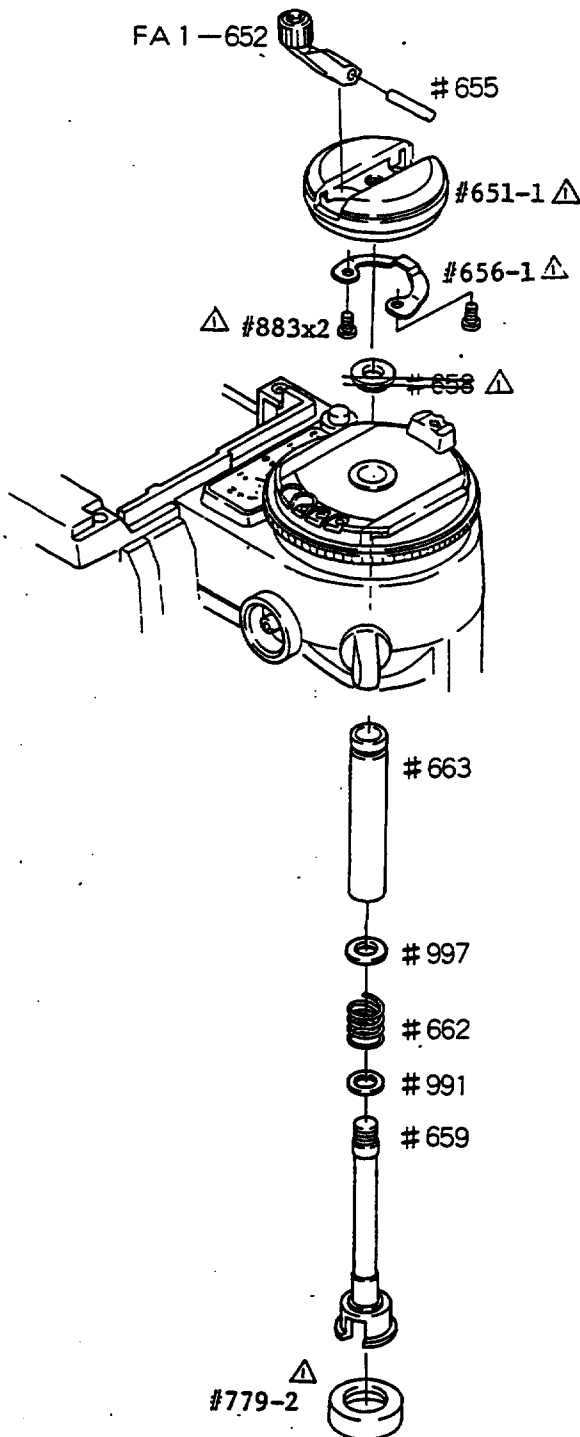

2-4 Top Cover, rewind side

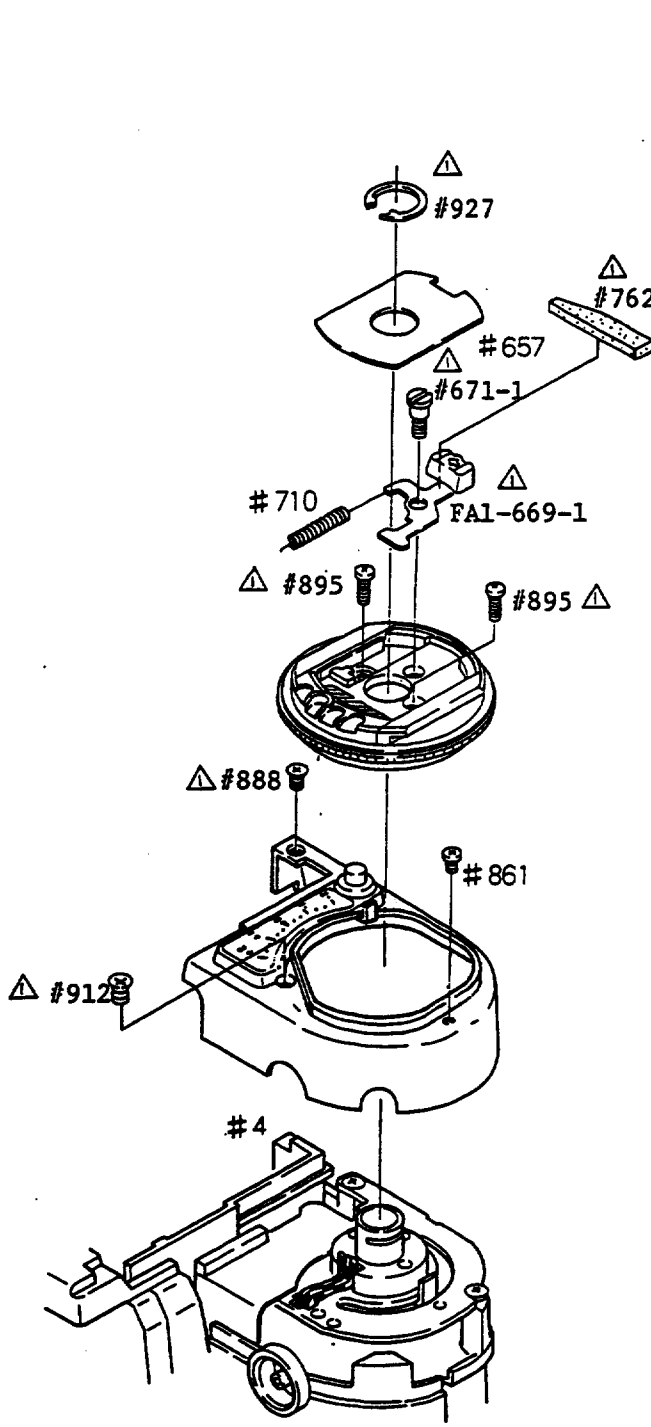

Snap ring #927 Δ

Tool: J5272

Cover #657

Spring #710

Screw #671-1 Δ

Tab FA1-669-1 Δ

Dissolder

Lead wire (orange) #1075

~~Lead wire (white) #1074~~ Δ

Lead wire (blue) #1073

Screw \oplus #895x2 Δ

Shoe FA2-664-1 Δ

Screw \oplus #861

Screw \oplus #888x1 Δ

Top cover, rewind side FA1-4

2-5 Display Block

Dissolder

Lead wire (orange) #1075
 Lead wire (white) #1074
 Lead wire (blue) #1073
 Lead wire (brown) #1078

Screw ⊕ #914 x 3
 Unit, rewind shaft FA2-661

Dissolder

Lead wire (violet) #1076
 Lead wire (orange) #1080

Screw ⊖ #669 x 2

Note: Loosen the one of #669,
 which locates near the
 front plate, first thing.

Screw ⊕ #864 x 3
 Display block FA1-132

Note: Use care not to damage
 the FPC.

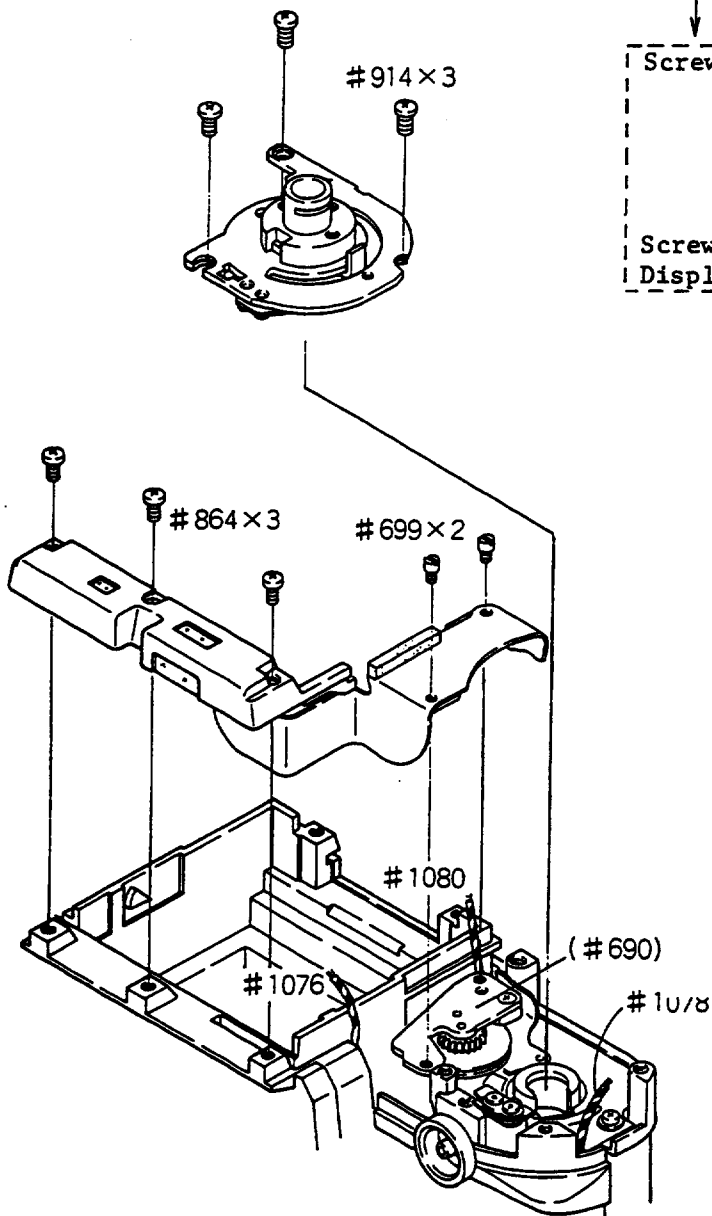

2-6 Bottom Cover

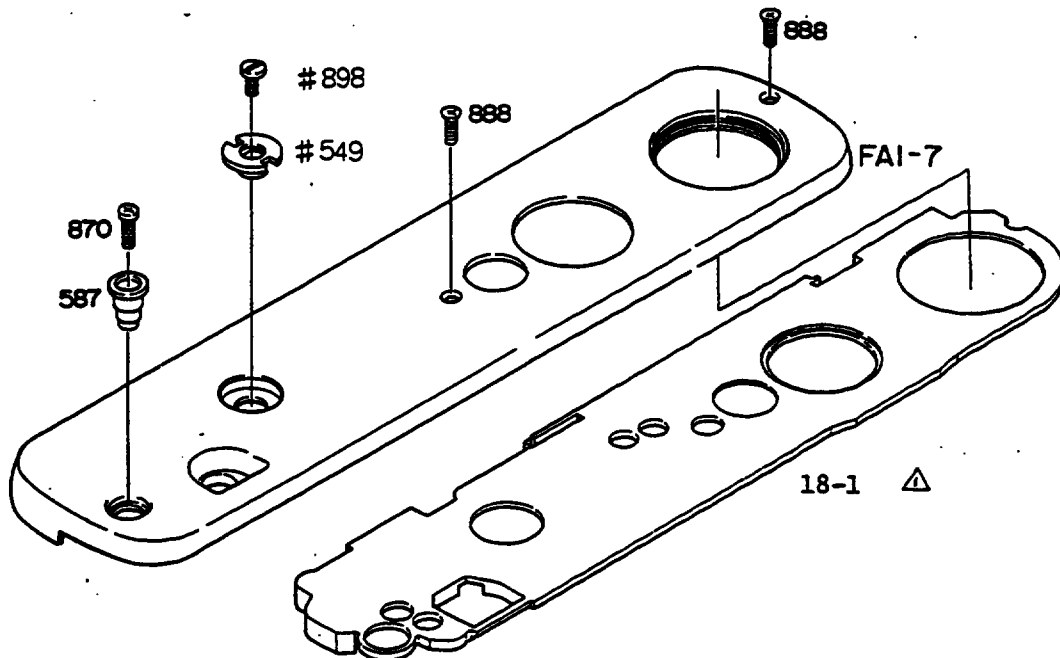
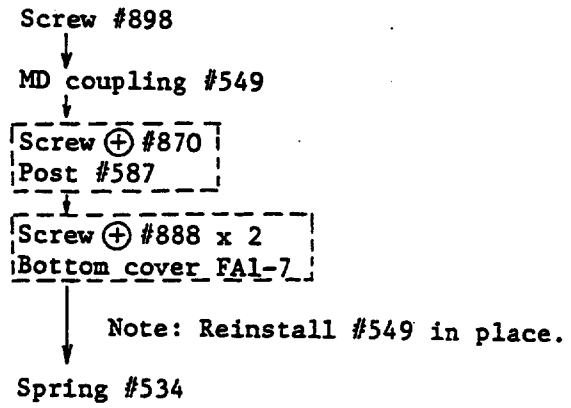

2-7 FPC (Unsoldering)

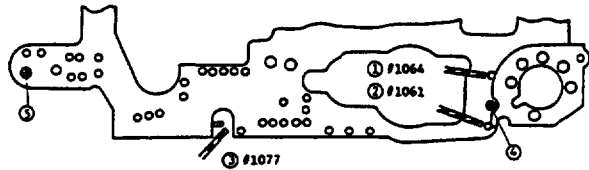

Unsolder:

- Lead wire (black) #1064
- Lead wire (red) #1061
- Lead wire (gray) #1077
- Terminal Vcc1
- Terminal Film-advance completion SW

Note: Remove the terminals with a solder-joint sweeper.

- Screw #911 △
 - ~~Washer #969~~ △
 - Nut #38
 - Cover, #12
- ↓
- Screw ⊕ #857

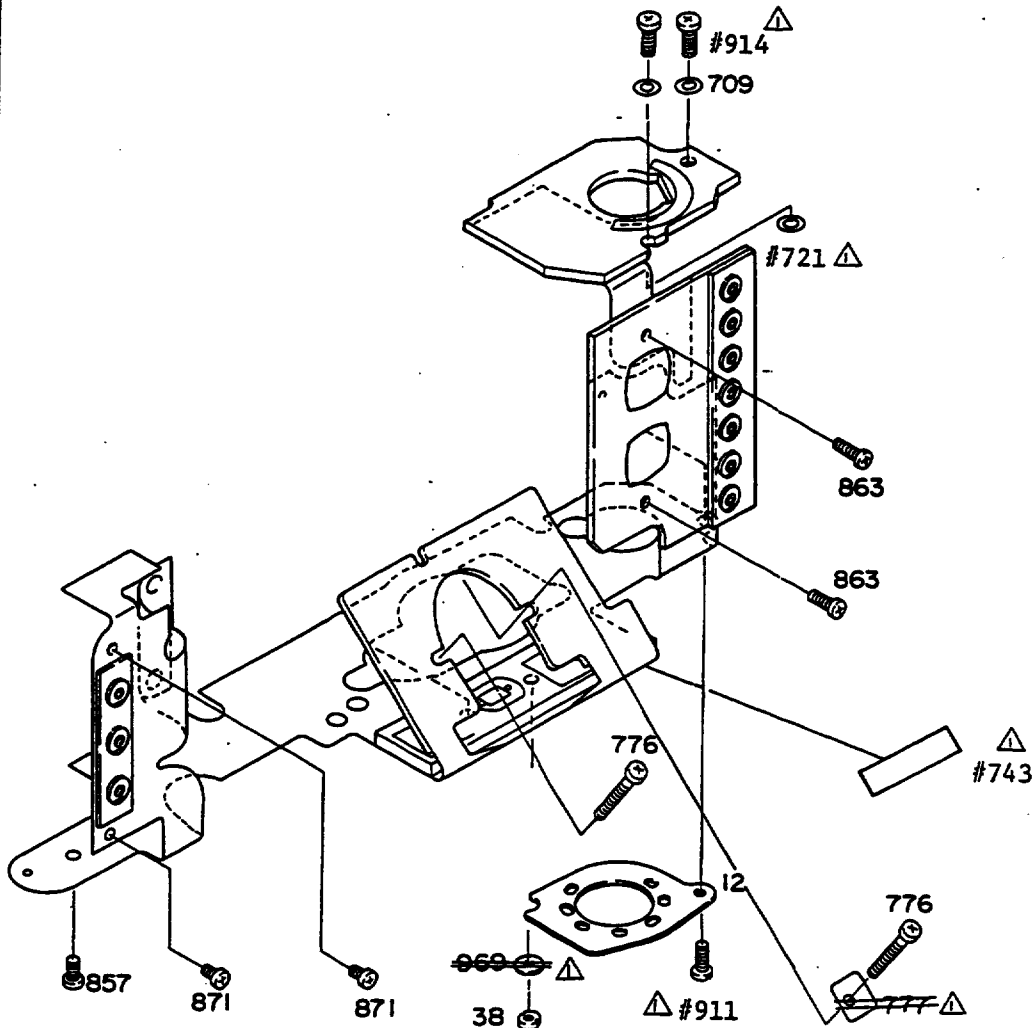

2-8 Rewind Lever

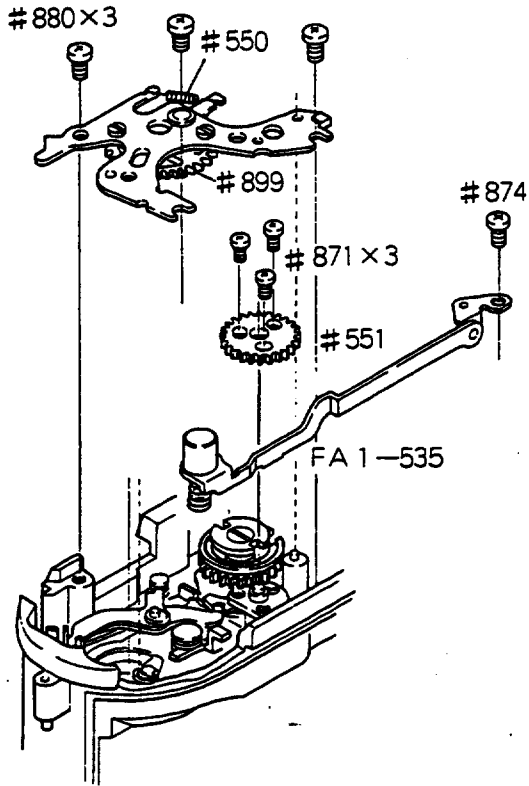

Screw ⊕ #880 x 3
Unit, sprocket gear FA1-565

Screw ⊕ #871 x 3
Sprock t gear #551

Screw ⊕ #874
Rewind lever FA1-535

2-9 Spool

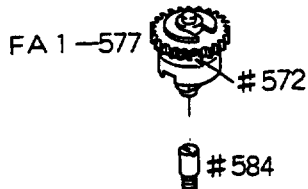

Spool friction FA1-577

Upper spool shaft #584
Spool FA1-582

Tool: J11161

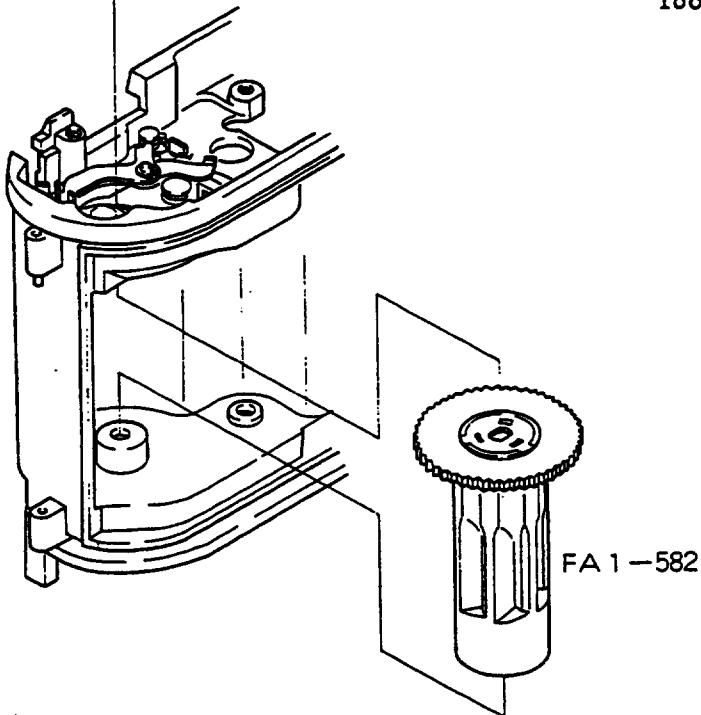

2-10 Film-advance Signal Unit/Multi-exposure Axle

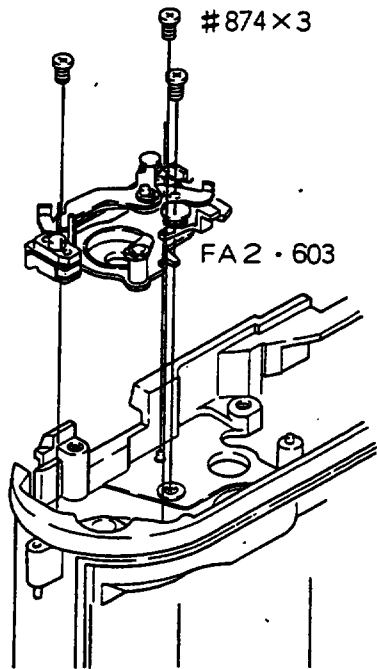

Screw ⊕ #874 x 3
 Unit, film-advance signal FA2-603

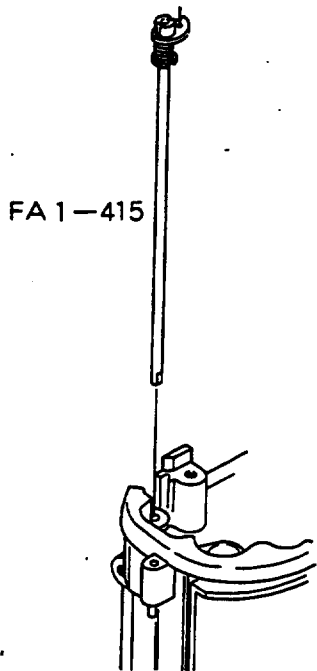

~~Screw ⊕ #904~~ △
 Screw ⊕ #907 △
 Coupler #413-1

↓
 Axle, multi-exposure FA1-415

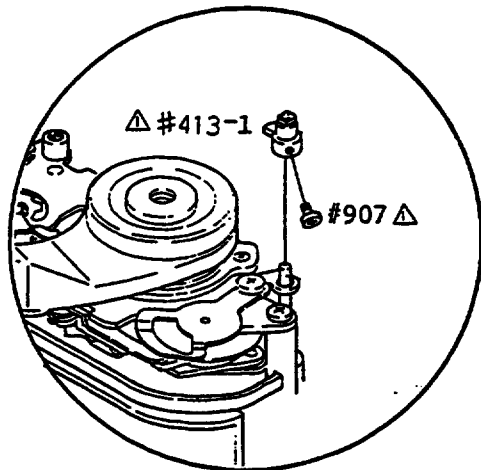

2-11 Front Plate (Unsoldering)

Unsolder

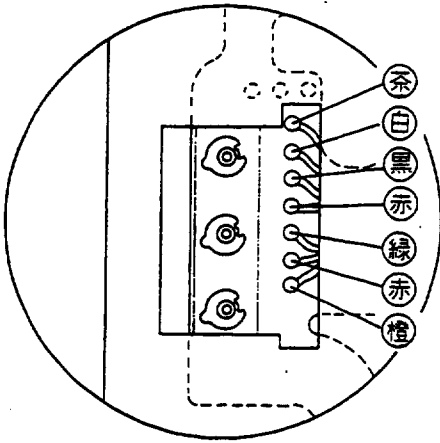

Lead wire (brown) #1066
 Lead wire (white) #1065
 Lead wire (red)
 Lead wire (black) Combination
 MG

Lead wire (green) #1083
 Lead wire (red) #1081
 Lead wire (orange) #1082

↓
 Lead wire (orange) #1080
 Lead wire (gray) #1077

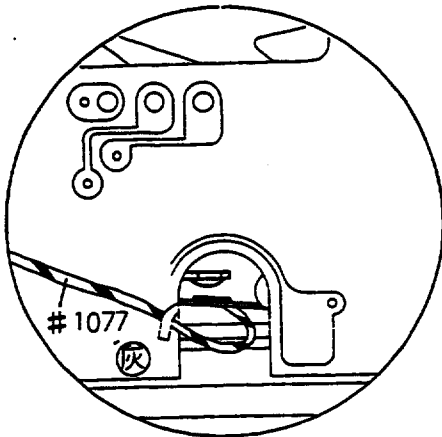
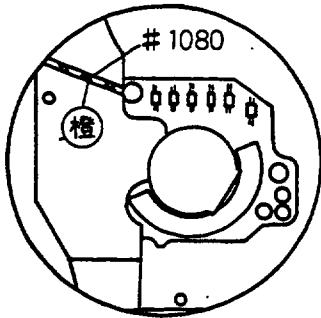

2-12 Front Plate Assembly

- Axle #524-1 Δ
- Spring #534 Δ
- Mirror cocking lever FA1-526

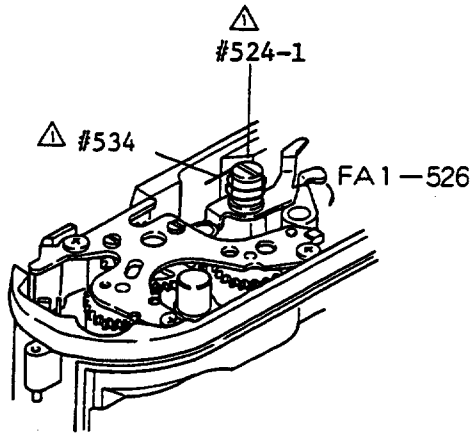

Note: When FA1-526 is in cocked condition, it can be removed easily.

When FA1-526 not removed, turn #524 2-3 turns to loosen. It allows FA1-526 to place aside in the direction of arrow.

- Screw \oplus #909 x 2
- Screw \oplus #882x6 Δ
- ~~Screw \oplus #882 x 2 Δ~~
- Fronte plate assembly FA3-6

Note: When the shutter is in released condition, it can be removed easily.

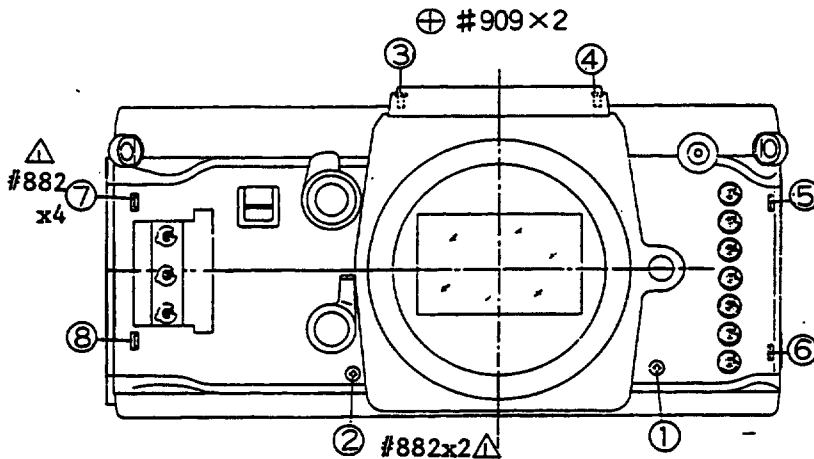

2-13 Combination Magnet

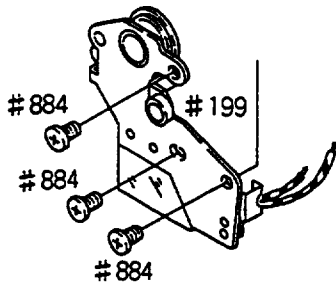

Screw ⊕ #884 x 3
Coil #199

~~Dfsolder~~
U:
削除

2-14 Shutter Switch

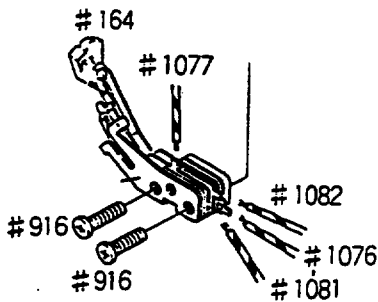

Lead wire (violet) #1076
Lead wire (gray) #1077

Screw ⊕ #916 x 2
Unit, shutter release SW FA1-751

2-15 Mechanical Release Lever

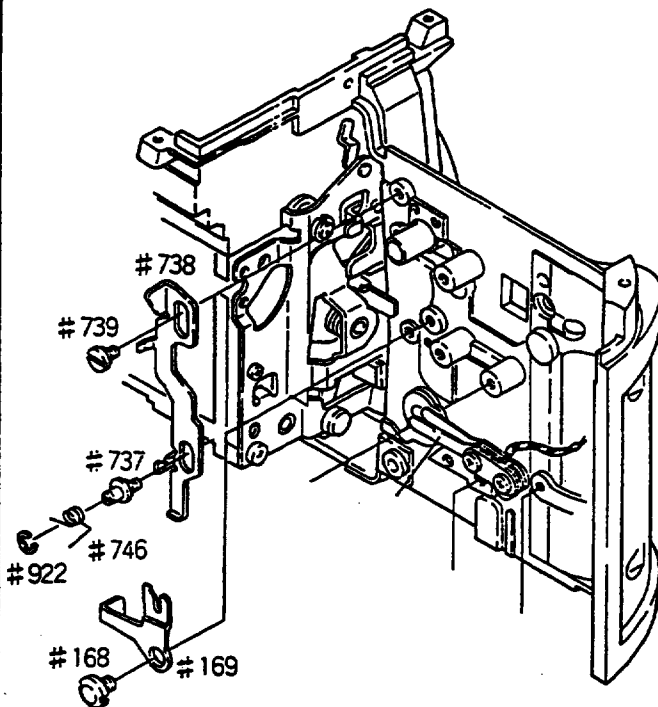

Axle #168
Coupling lever #169

Tool: J11162

Snap ring #922
Spring #746

Axel #737
Screw - #739
Lever #738

2-16 Mirror Holder

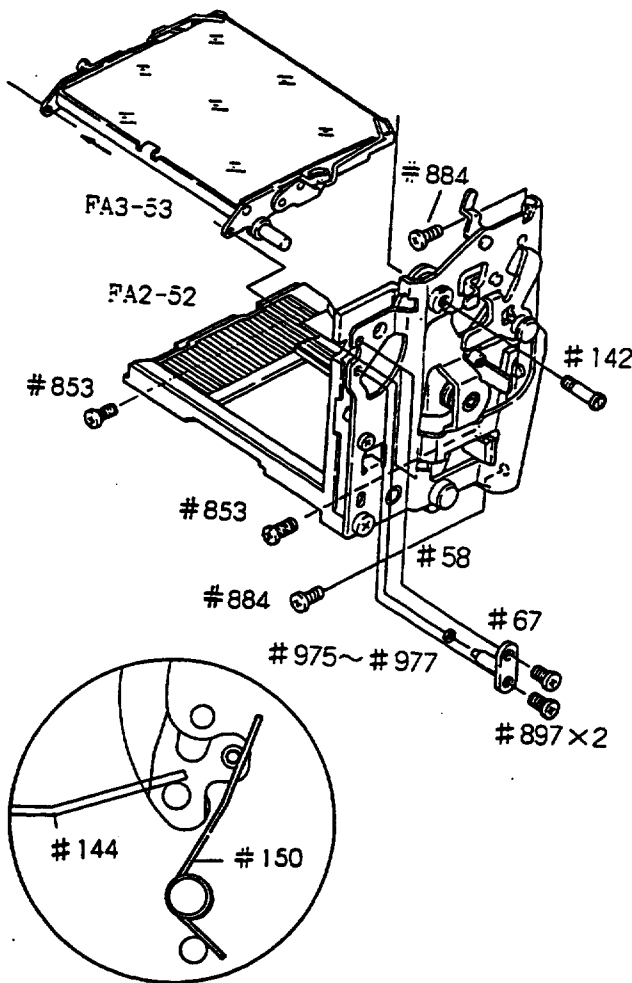

Spring B #144
Spring #150

Screw ⊕ #897 x 2
Mirror bearing shaft #67
Washer #975

Note: Use care not to fall #975

Screw ⊕ #853 x 2
Screw ⊕ #884 x 2
Screw ⊖ #142 x 1
Unit, mirror-box actuating FA2-52

Mirror holder FA3-53

2-17 Mirror Box Unit, rewind side

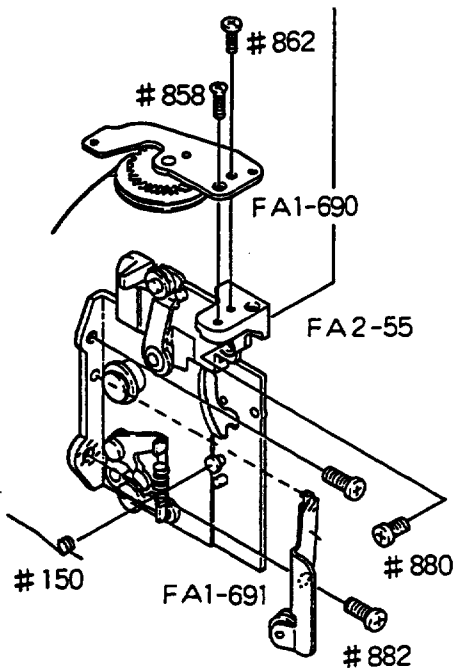

Screw ⊕ #881 x 1
Screw ⊕ #882 x 2
Unit, mirror-box(rewind side) FA2-55
Unit base FA1-690
Unit base FA1-691

2-18 Take-up Gear Unit

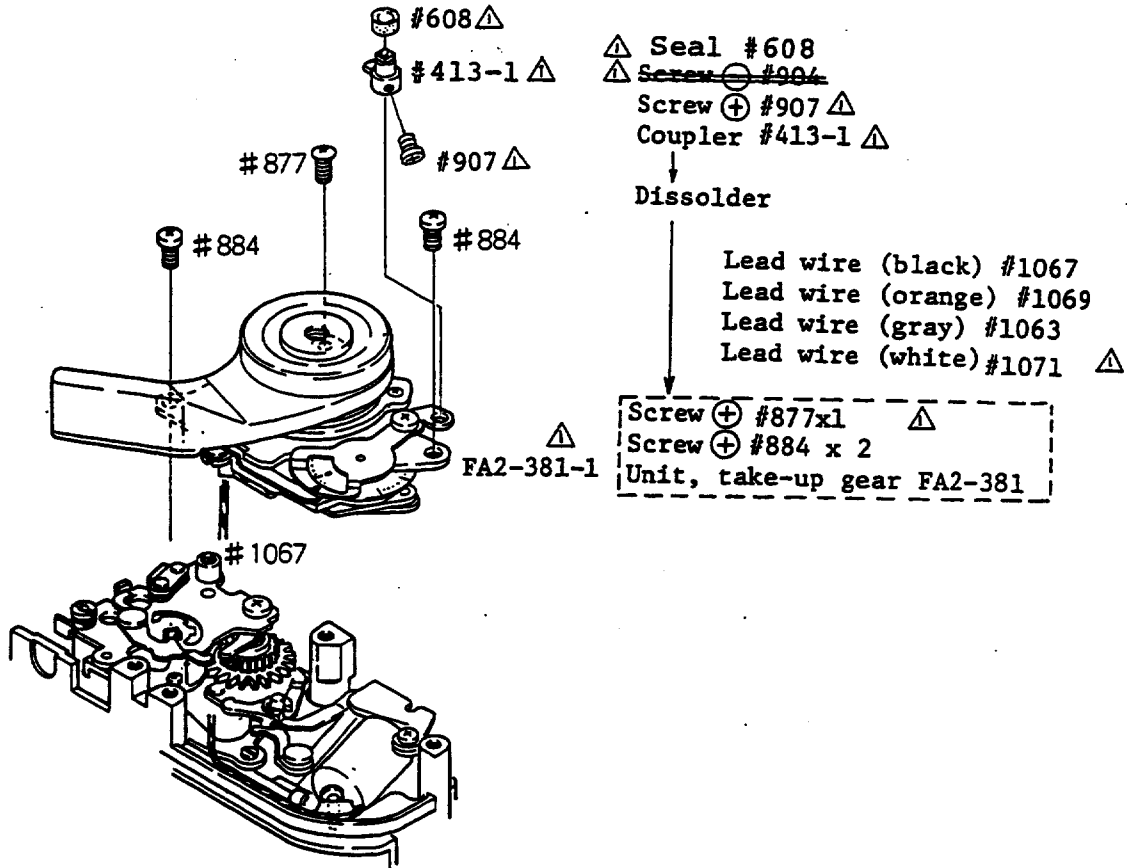

2-19 FPC Holder

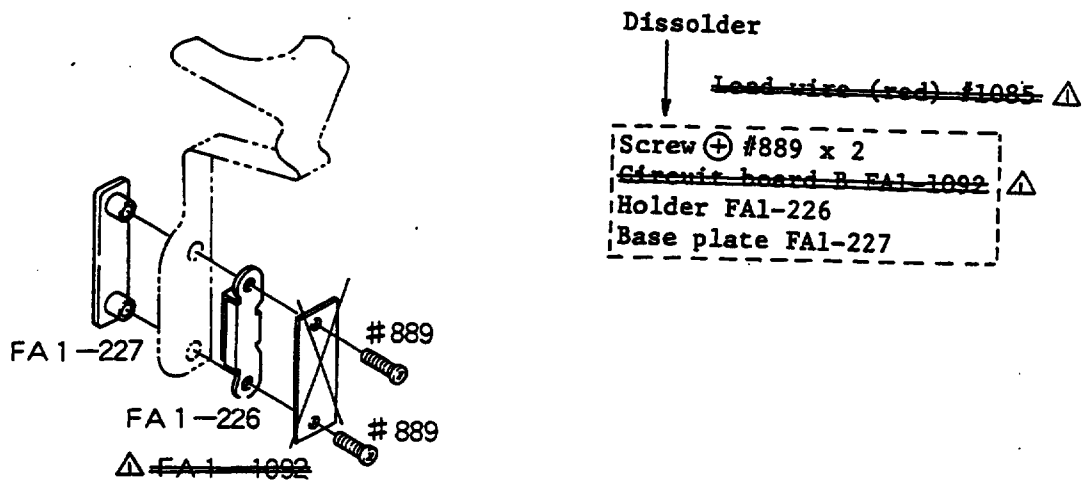

2-20 Shutter Speed Selector

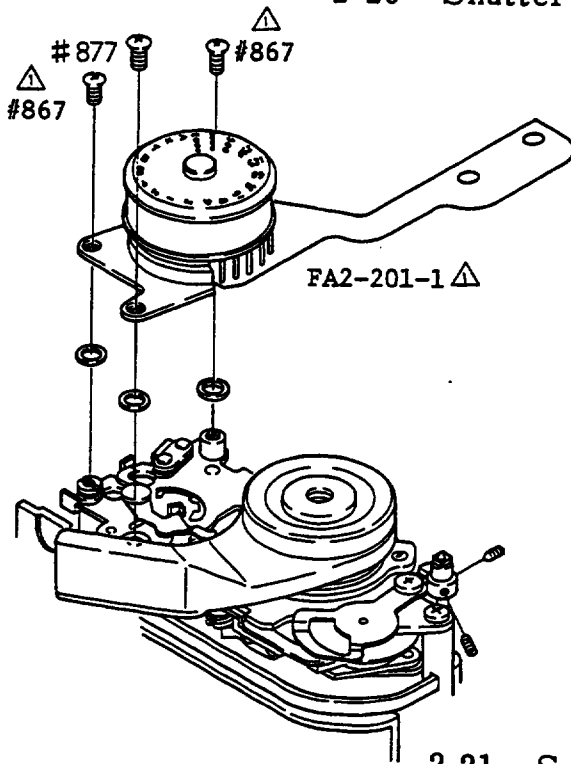

- Screw ⊕ #867x2 △
- Screw ⊕ #877
- Shutter speed selector unit FA2-202-1 △

Note: Use care not to lose the washer installed under FA2-201-1. △

2-21 Sprocket

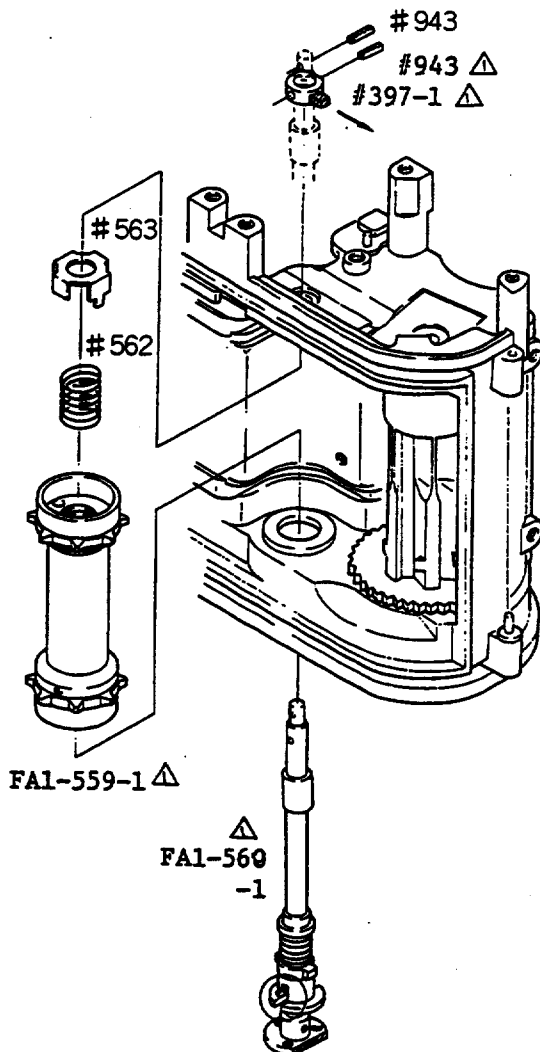

- Spring cotter #943x2 △
- ~~Spring cotter #943~~ △
- Take-up stopper #397

↓
Sprocket shaft FA1-560-1 △

Note: When removing FA1-560-1 hold Sprocket with fingers △

- Holder #563
- Spring #562
- Sprocket FA1-559-1 △

Note: Use care not to lose #562.

2-22 FPC (Unsoldering)

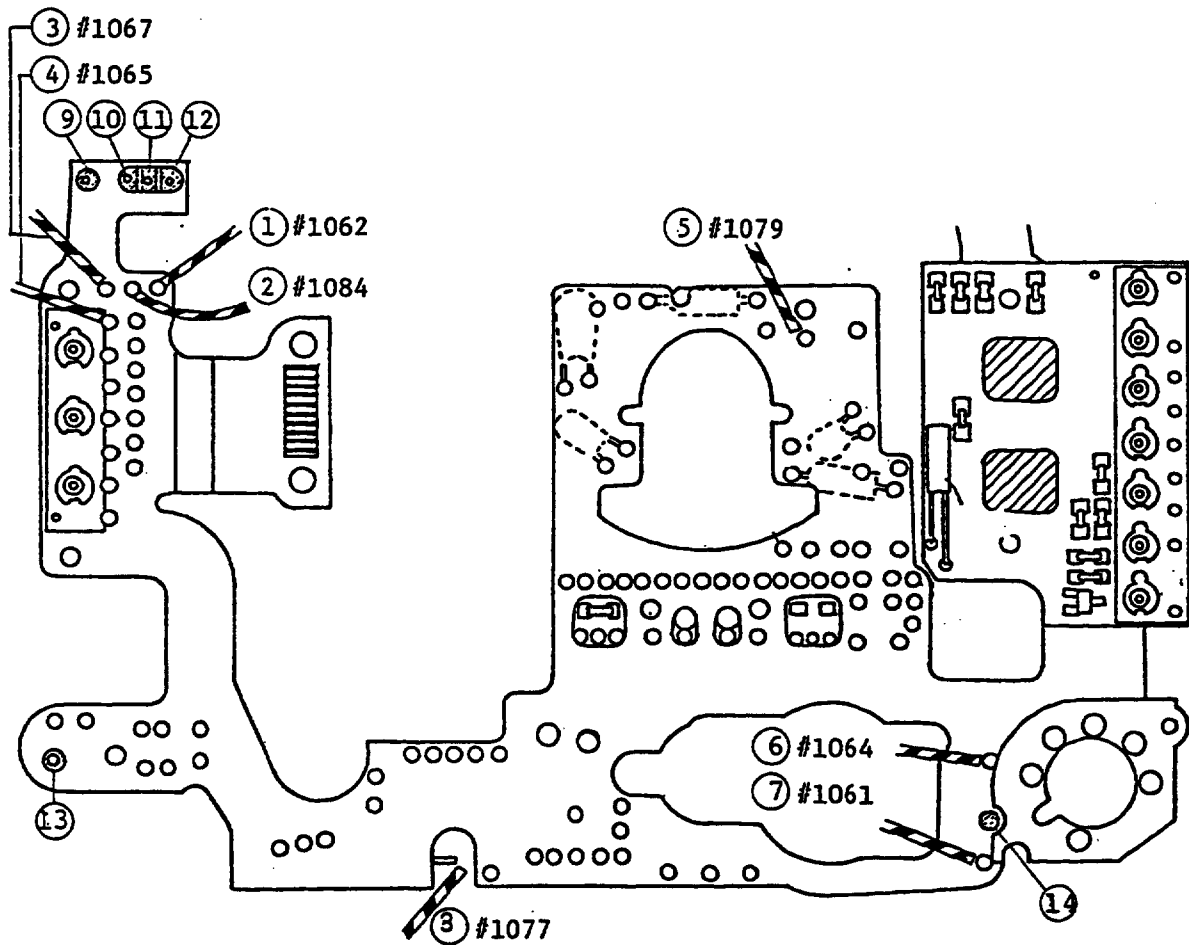

Unsolder

- | | |
|---|-------------------------------------|
| ① | Lead wire (yellow) #1062 |
| ② | Lead wire (blue) #1084 |
| ③ | Lead wire (black) #1067 |
| ④ | Lead wire (white) #1065 |
| ⑤ | Lead wire (black) #1079 |
| ⑥ | Lead wire (black) #1064 |
| ⑦ | Lead wire (red) #1061 |
| ⑧ | Lead wire (gray) #1077 |
| ⑨ | Terminal Closing curtain MG |
| ⑩ | Terminal Vccl |
| ⑪ | Terminal Trigger SW |
| ⑫ | Terminal Closing curtain SW |
| ⑬ | Terminal Vccl |
| ⑭ | Terminal Film-advance completion SW |

Note: Remove the terminals with a solder-joint sweeper.

2-23 FPC

Note: Careful - FPC is a fragile part. Use a pair of cotton gloves to touch it. Probing fingers can cause instant damage of the variable resistors or the infrared-solder joints.

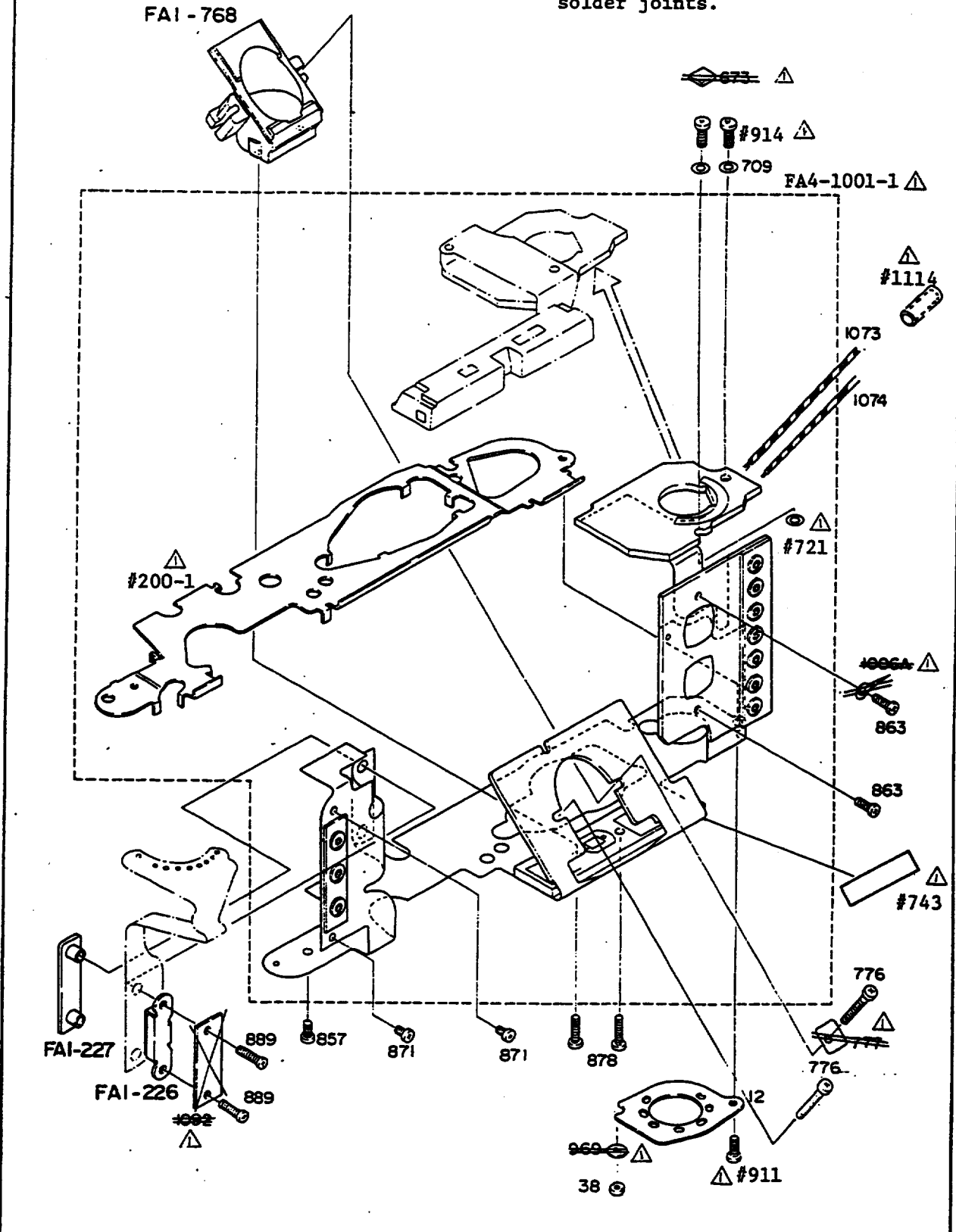

2-24 Incomplete Gear

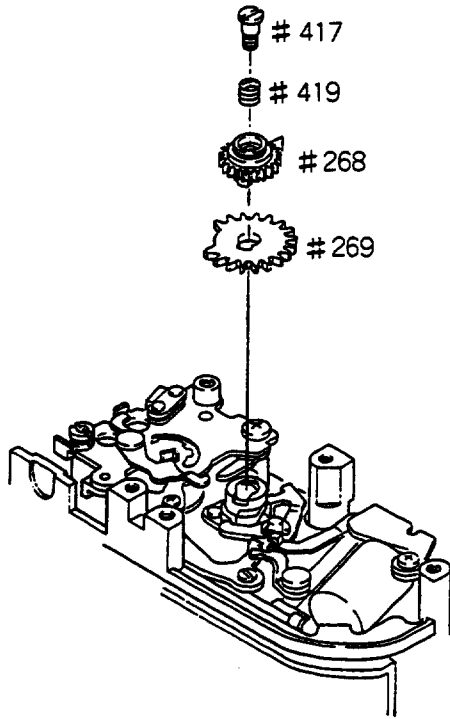

Screw ⊖ #417
Spring #419

↓
Take-up gear #268
Spring #369

↓
Incomplete gear #269

2-25 Connecting Shaft/Shutter Unit

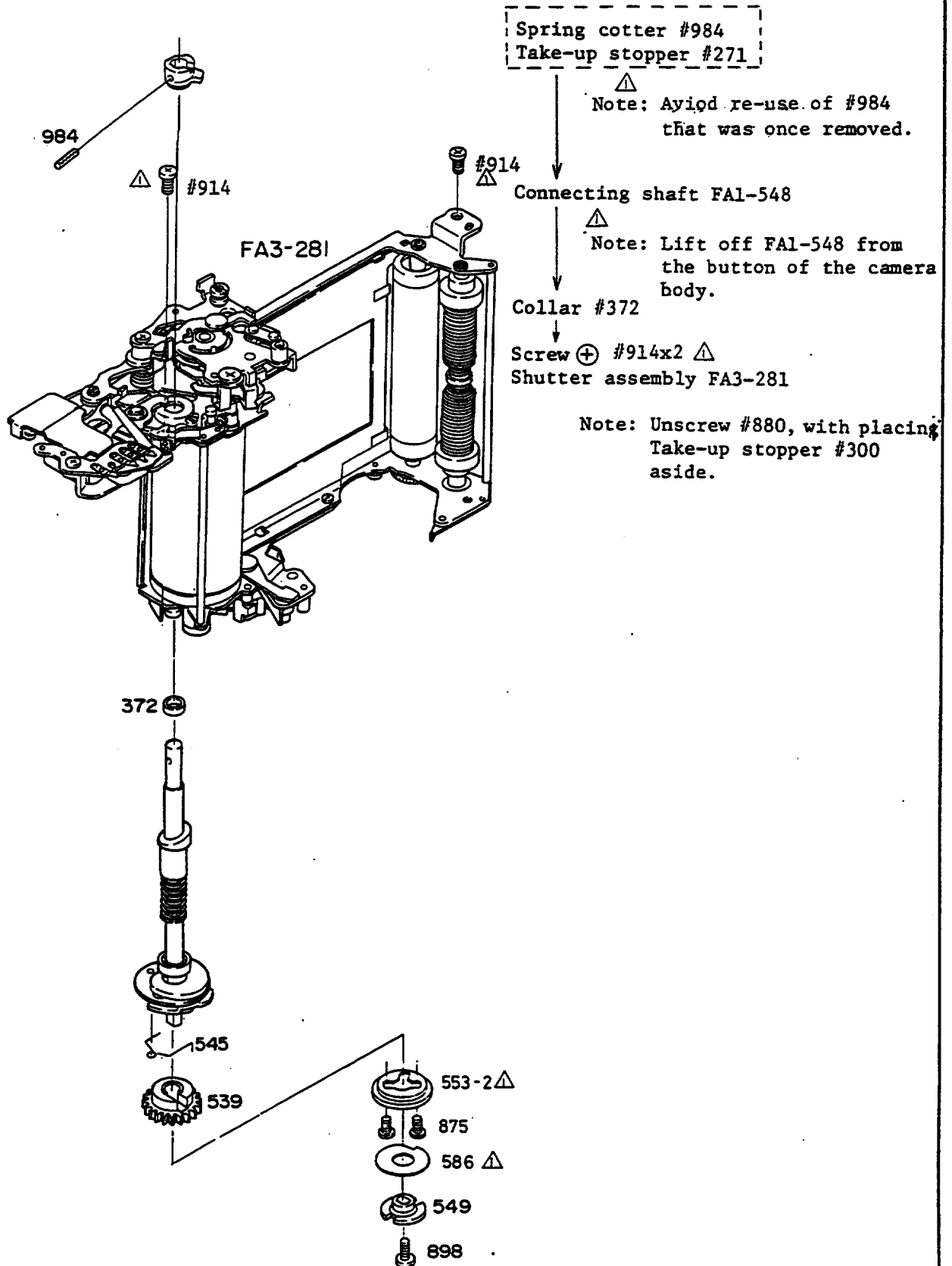





3.1 Unit, film-advance completion signal

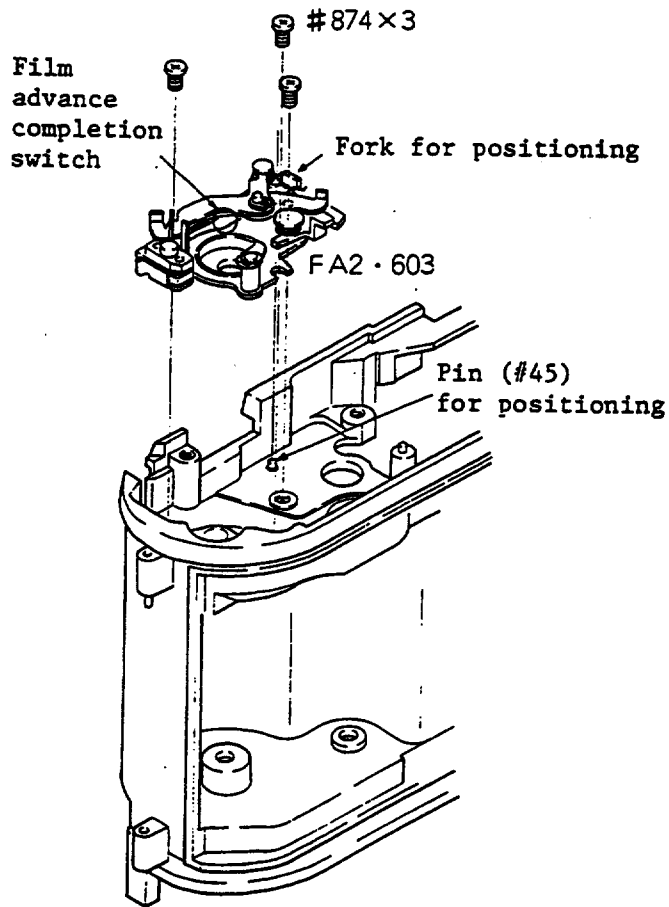

Body die-casting

↓
Unit FA2-603,
Screw ⊕ #874 x 3

Install #603 in place, after catching Pin (#45) with the fork for positioning. (See fig. 1-1.)

Install Spring #614 as shown in fig. 1-2.

Adjust the space gap between Switch #601 and Switch #602. (See P. A6)

Check the smooth movement of Lever #597, Set lever #593 and Lock lever #613. (fig. 1-2)

fig. 1-1 Body, wind side; with bottom up

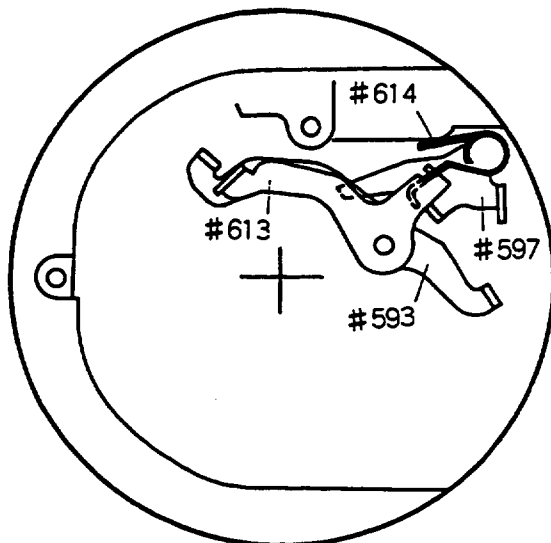
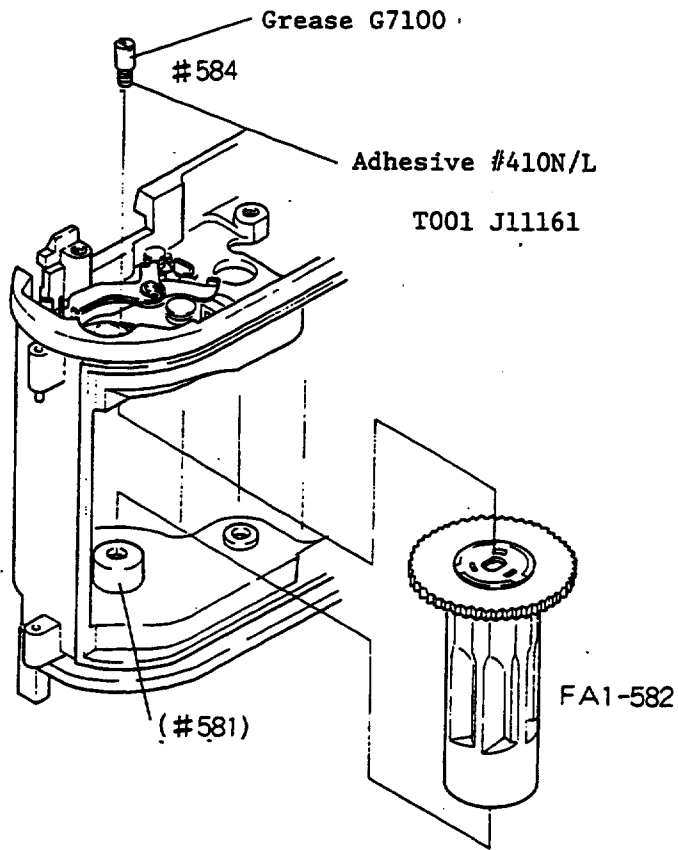

fig. 1-2 Body, wind side; bottom

3-2 Spool



Body die-casting



Spool FA1-582



Upper spool shaft #584 ⊖

Apply Lock-tight 410 N/L onto the screws of Spool holder #581.

Note: Use a long-blade screwdriver to install #584. (J11161)

fig. 2-1| A2 Body, wind side; with bottom up

3-3 Sprocket

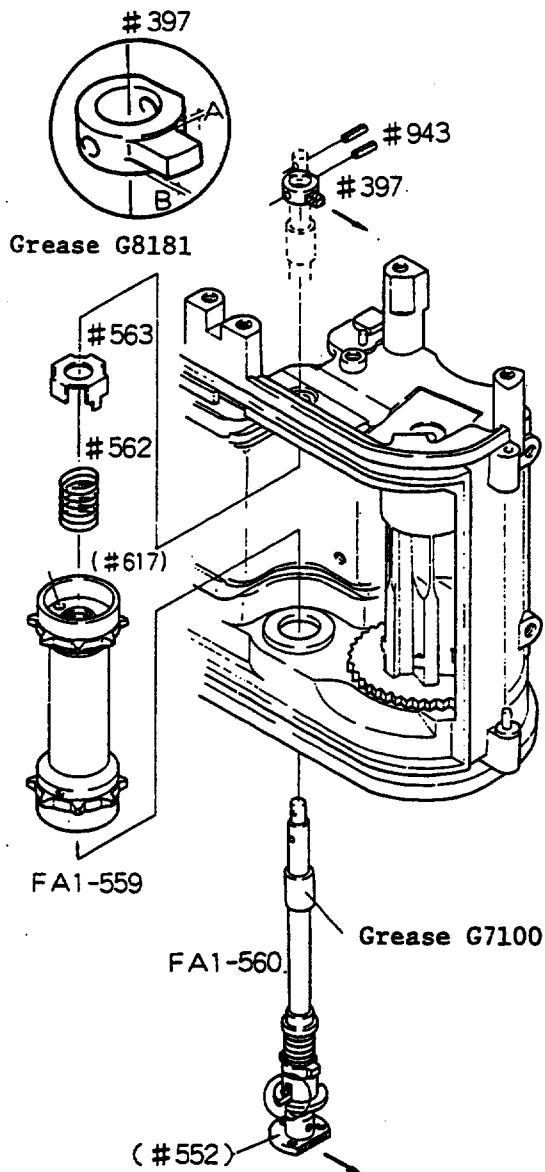

fig. 3-1 Body, wind side

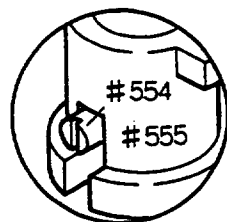

fig. 3-2

Body die-casting

Use G8181 to lubricate the mating surfaces of Top bearing #564 and Holder #563.

Holder #563
Spring #562
Sprocket FA2 - 559

When installing #563 into #559, use care to drop the two protrusions into the holes. (See fig. 3-1.)

Sprocket shaft FA1 - 560

Pass #560 through the sprocket, after putting Sprocket pin #554 into the groove of Rewind button claw #555. (See fig. 3-2.)

Take-up stopper #397

Watch out for the relative positioning between #397 and Disk #552 as shown in fig. 3-1

Spring cotter #943

Use Pliers J15081 to pass #943 through #397 and #560, with the holes aligned.

Note that the positioning of the sprocket teeth is referred to P. A12 .

Spring cotter #943

(Use Pliers J15081 to pass #943 through #560.)

Protrusion of #943 through the sprocket shaft should be equal at the both ends.

Check the sprocket for smooth rotation.

3.4 Shutter Assembly

Body die-casting



Shutter assembly FA3-281, Screw ⊕#880
x 2

- 1) Placing the protrusion of #397 aside makes it easier to install the shutter.
- 2) Install the shutter, aligning the positioning holes with Pin #42.

Note that when replacing the shutter, it is not necessary to make adjustments for its accuracy. A spare shutter is fully adjusted at factory to ensure proper operation.

However, be sure to check #300 for engagement and Contact #323 for its ON-timing. (See P. A7)

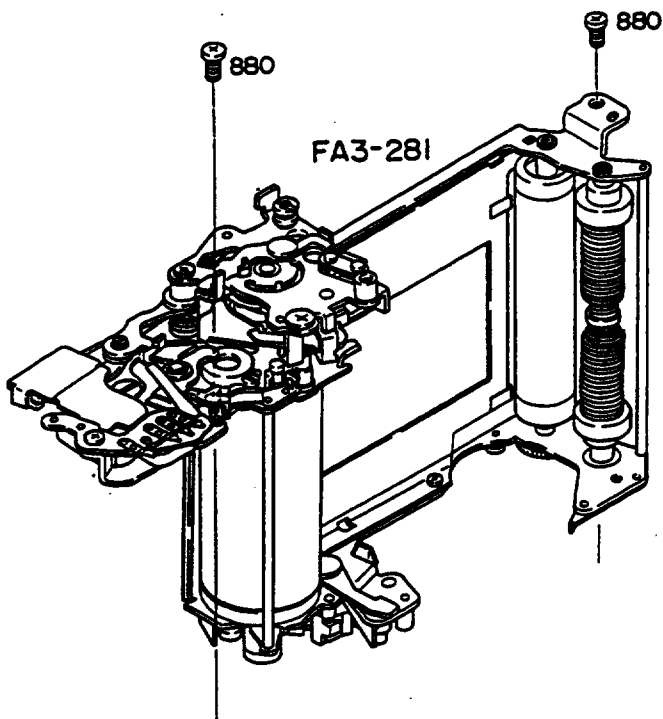

3.5 Connecting Shaft

Body die-casting



Collar #372

Connecting shaft FA1-548



Note that when replacing either #548 or Take-up stopper #271, change both of them at a time.

Take-up stopper #271

1) Turn Take-up disk (#543) until it positions at the final stage of film-advancing. (Lever #597 is being engaged with #543.) See fig. 5-1.

2) Install #271 in place as shown in fig. 5-2.
Use Tool J14017.

Spring cotter #945, Tool J14017

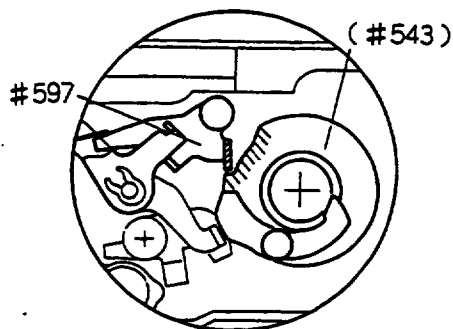
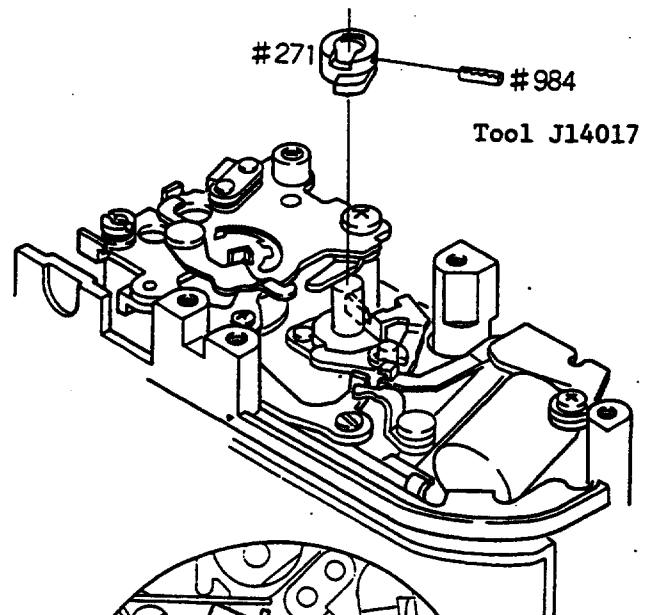
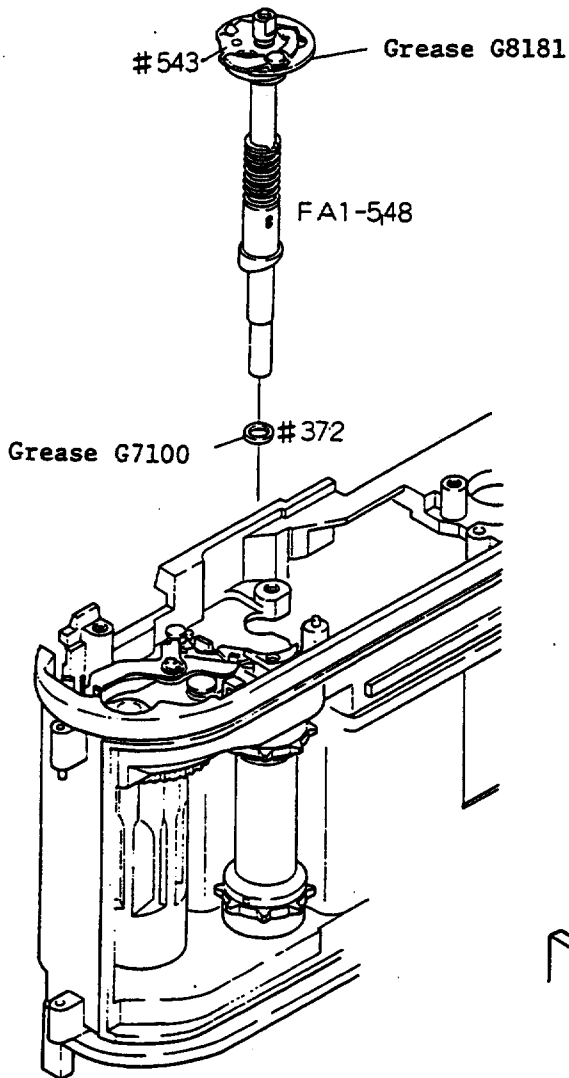

fig. 5-1 Body, wind-side, bottom

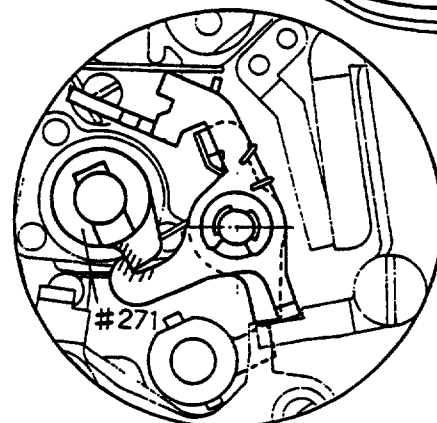

fig. 5-2 Body, wind-side, top

3.6 Switch, film-advance completion signal

Use a ohmmeter to check the switch for its ON - OFF timing. Connect the test prod positive to Switch B #602, and the negative to the camera body.

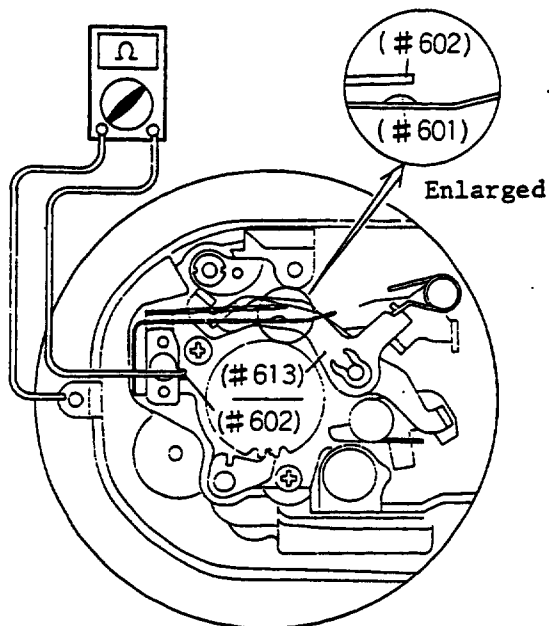

fig. 6-1 Body, wind-side, bottom

Film-advancing cycle	ON/OFF	Clearance between the contact blades	fig. No.
End	OFF	0.5 - 0.8mm	6-2
Shutter release	OFF	0.5 - 0.8mm	6-2
Start	ON	0	6-3
Halfway	ON	-0.2 - -0.3	6-4
End	OFF	0.5 - 0.8	6-2

Adjustments can be made by bending the contact blades.

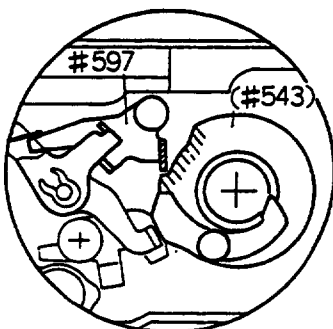

fig. 6-2 End of film-advancing

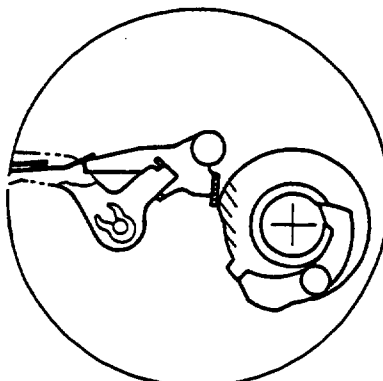

fig. 6-3 Start of film-advancing

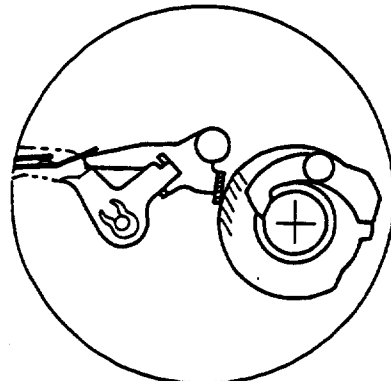

fig. 6-4 Halfway of film-advancing

3-7 Take-up Stopper #300's Engagement & Contact #323's ON-timing Adjustment

Take-up Stopper #300's engagement

- 1) Set Take-up stopper #271 to the shutter-cocked condition.
- 2) Engage Section (a) of Charge lever #293 with Time lever (#238).
- 3) Engage Take-up stopper #300 with Lever #339, turning in the direction A.
- 4) Placing #271 in the direction B to be engaged with #300, check the depth of engagement.

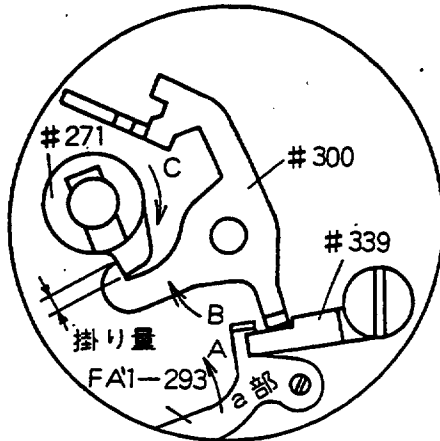

fig. 7-1

Depth of engagement between #271 and #300 to be 0.6 - 0.9mm. \triangle

Note that when the disengagement between #271 and #300 occurs, the film-advance lever fails to advance the film and cock the shutter even when fully stroked.

Contact, closing curtain switch #323's ON-timing

Disengage #339 from #300 by holding #339 with a tweezers to reverse slowly. At this time, see if #323 turns on after #300 unlatches #271.

Adjustment can be made by bending Spring #308.

Note that when the ON-timing is too early, the motor drive stops working with its safety device: the start signal of film-advance must not be transmitted to the motor drive before #300 unlatches #271.

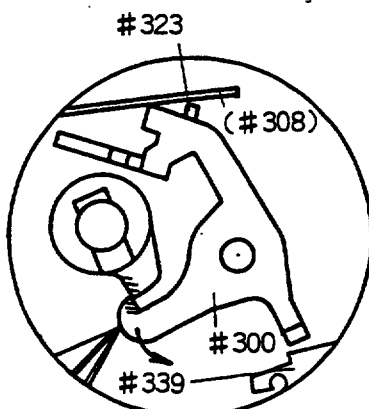

fig. 7-2

3-8 Take-up Gear & Incomplete Gear

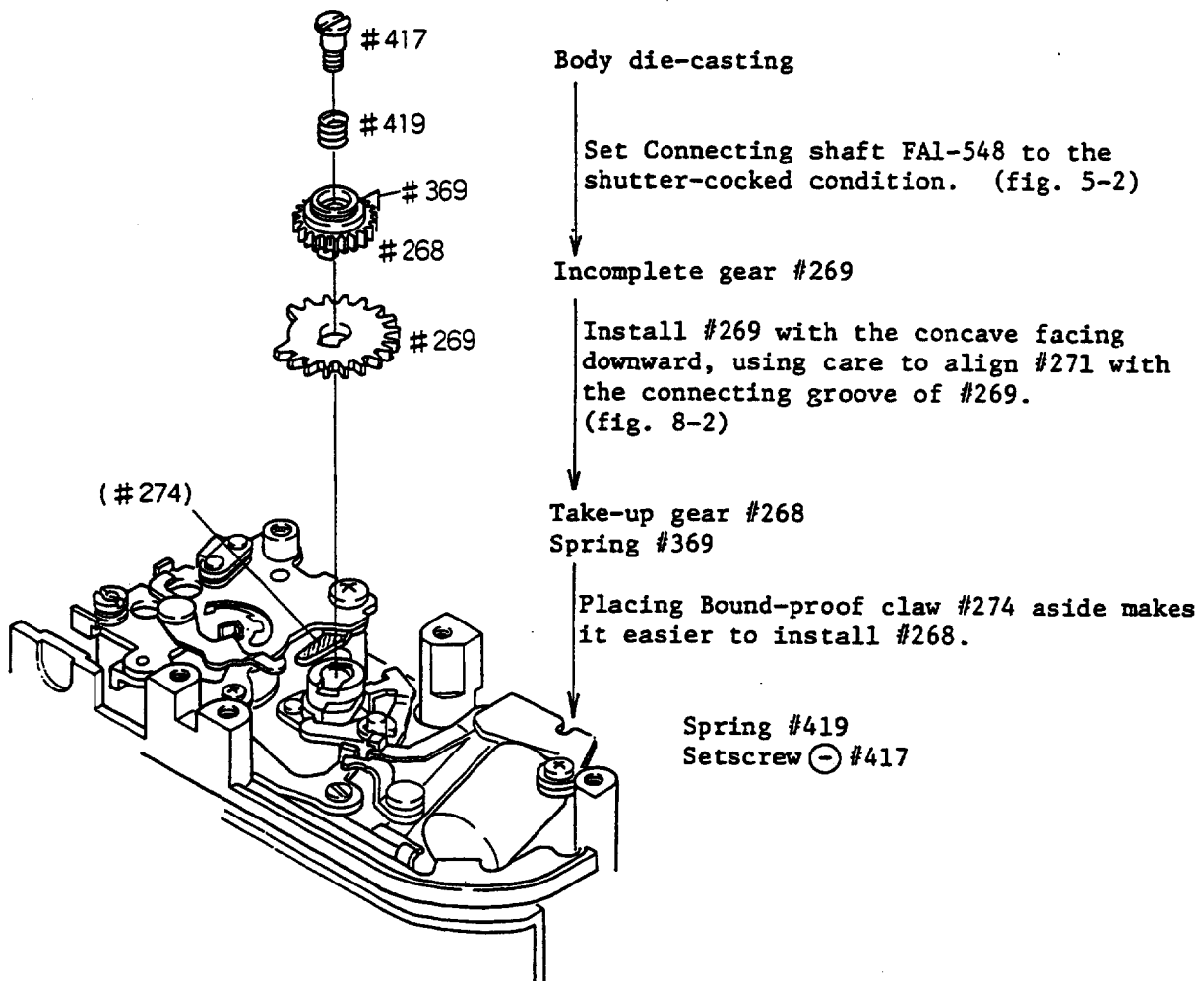

fig. 8-1. Body, wind-side, top

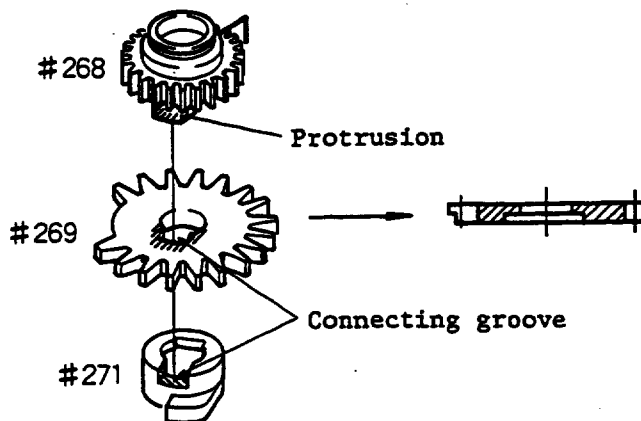

fig. 8-2 #269 installation

3-9 Lower Gear Connecting shaft, Rewind Lever & Axle, multi-exposure

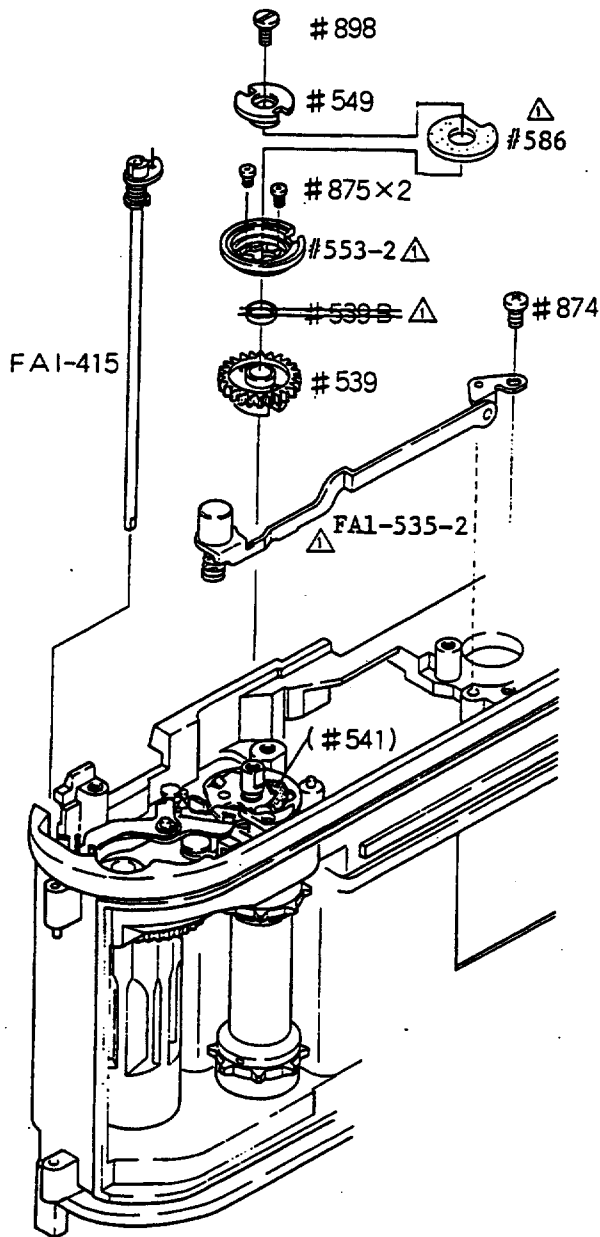

fig. 9-1 Body, wind-side; with bottom up

Body die-casting

Lower gear #539

Place Take-up claw #541 aside when installing #541.

~~Collar #539B~~ Δ

Spacer #553-2 Δ

Temporarily fix with Screw \oplus #875 x 2
For adjustment, refer to P. A13

Seal #586 Δ
MD coupling #549

Temporarily fix with Screw \oplus #898.

Rewind lever FAI-535-2 Δ
Screw \ominus #874

Check the riwind button for smooth movement after installing Unit base FAI-565.

Axle FAI-415

Engage Spring #592 as shown in fig. 9-2

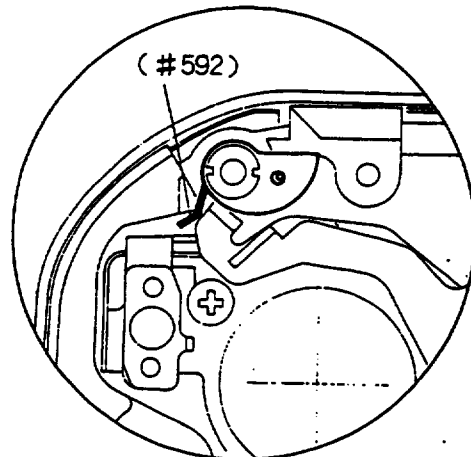

fig. 9-2 Spring #592

3-10 Sprocket gear, Lower Spool Shaft & Unit Base, sprocket

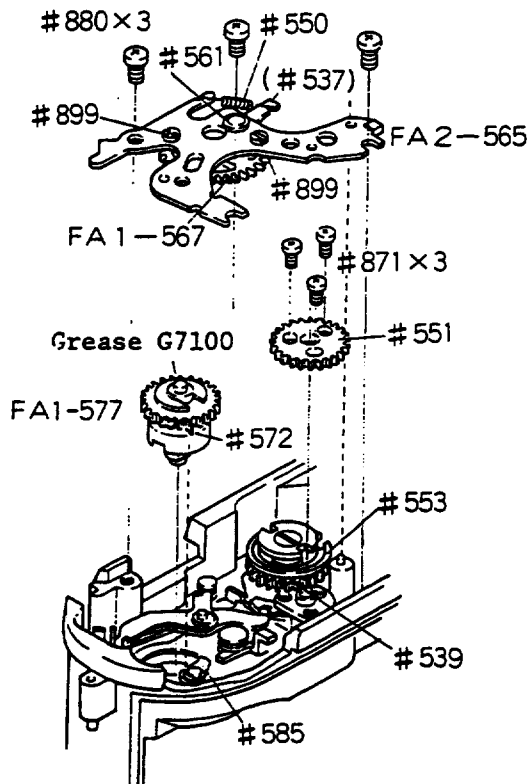

fig. 10-1 Body, wind-side, top

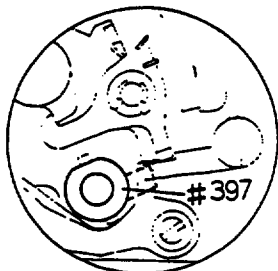

fig. 10-2

Body die-casting

Sprocket gear #551
Screw ⊕ #871 x 3

Set FA1-548 to the shutter-cocked condition and engage #551 with Lower gear #539, being careful to align the screw hole with the center of the oval hole.

Further adjustments of #551 should be made according to P. A12 .

Spool friction FA1-577.

Put Spring #572 into the cut-out of Spool reverse stopper #585.

Unit FA1-565
Holder FA1-567
Screw ⊕ #880 x 3

Catch Pin #46 with the positioning hole when installing FA1-565.

The rotation of Spool idler #569 is adjustable by re-locating FA1-567.

Prior to adjustment, Screws #899 x 2 should be loosened.

Spring #550

3-11 Unit, take-up gear

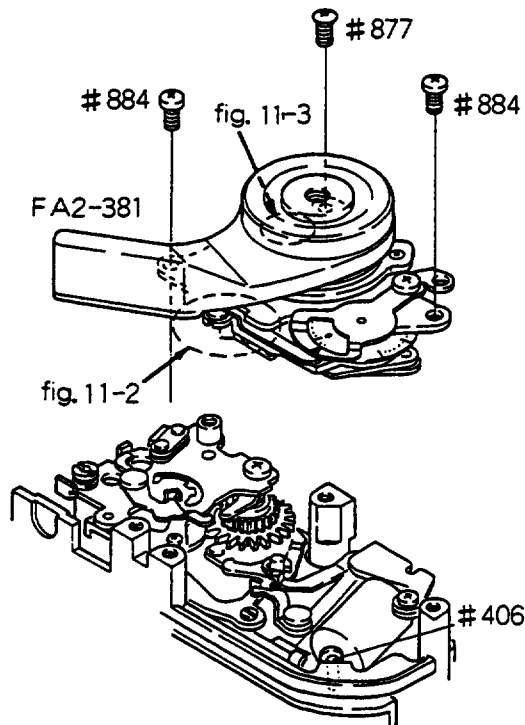

fig. 11-1 Body, wind-side, top

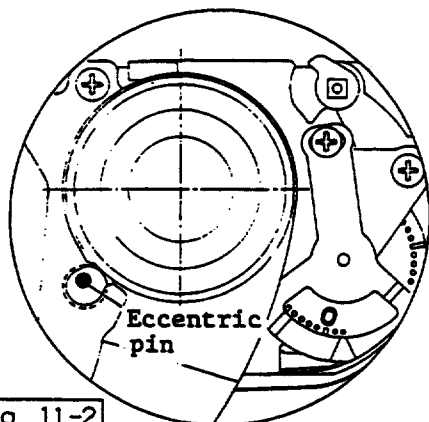

fig. 11-2 Eccentric pin #394

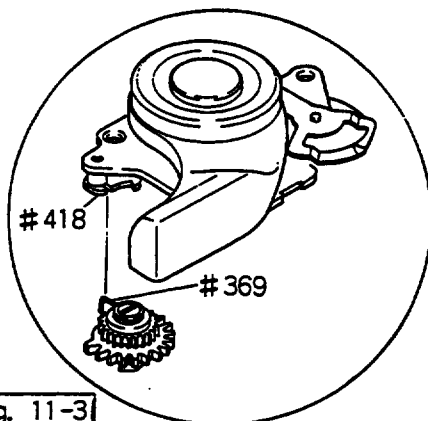

fig. 11-3 Reverse stopper claw #418

Body die-casting

Set the camera body to the shutter-cocked condition. Check to see if Pin #406 is installed.

Unit, take-up gear FA2-381

Turn Frame counter coupling (#396) to set Eccentric pin #394 as shown in fig. 11-2.

When installing, engage Spring #369 with the cut-out of Reverse stopper claw #418. (See fig. 11-3.)

Screw ⊕ #877

Screw ⊕ #884 x 2

Check points

- 1) Make sure that #369 will not dislocate when stroking the film-advance lever with a series of strokes.
- 2) Check the frame counter for proper operation by stroking the film-advance lever slowly or swiftly.
- 3) See if the frame counter will smoothly return to the start position when opening the camera back.
- 4) See if index aligns with the calibrations properly.

3-12 Sprocket Gear Engagement

3-12-1 Sprocket Gear Engagement

- 1) Hold the camera body upside down and keep the film-advance lever at the fully-stroked position by your thumb. Then, loosen three Screws #871 to latch #271 with #300. (fig. 12-2)

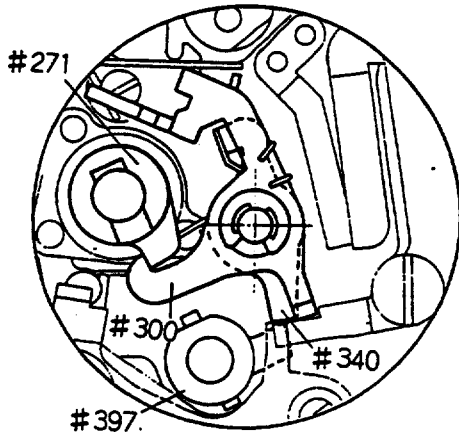

fig. 12-1

3-12-2 Plate, sprocket lower gear Engagement

- 2) Turn the sprocket toward the spool until it is stopped by the interference of #397 with #340. At this time, re-tighten #871, with #551 placing in the direction of arrow. (See fig. 12-2.)

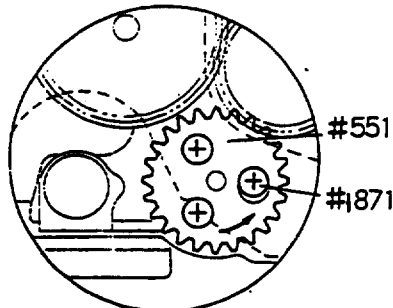

fig. 12-2

Note that #271 should be stopped by #300, before #397 is stopped by #340.

Play of the tip of sprocket tooth to be 0.4 - 0.8mm after film-advancing.

Sprocket Teeth Positioning

See P.9 of Repair Manual of FE. Positioning of the sprocket teeth can be made in the same procedure as the FM and the FE.

Standard: $31.85 \pm 0.4\text{mm}$

When using J18064, be sure to scribe new reference line for 40FB as shown in fig. 12-3.

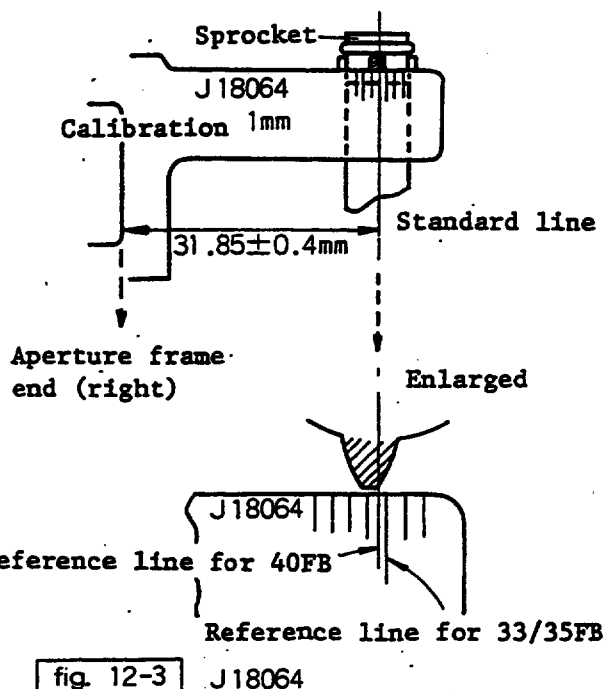

fig. 12-3

To avoid loosening after installation, be sure to drill a small hole at the bottom of one of the threaded holes for #936, then drive #936 securely.

Also apply adhesive #410 B/M. onto other two #936s.

After cocking the shutter, hold the film-advance lever by your finger. And then, place the sprocket toward the rewind side to check the clearance between Plate #553 and Stopper #537.

Standard: 0.05 - 0.3mm \triangle

- \triangle Adjustments can be made by turning the eccentric pin of #553 after loosening #875. When re-screwing, use care not to overtighten #875. (Tightening torque: 0.75kg). Apply a locking agent to #875 and the eccentric pin.

SUPPLEMENT: SPROCKET TEETH POSITIONING

To avoid loosening of sprocket or to simplify the positioning procedure, four openings are made around Sprocket inner tube #556 and one of Setscrews #936 is eliminated.

Sprocket teeth positioning with this new inner tube can be made by selecting the alignment of two through-holes of sprocket with four openings of inner tube. See the figure.

First align through-hole A with opening 1 and then use J18064 to measure the deviation of sprocket teeth. Unless the deviation is within $\pm 0.34\text{mm}$, the alignment should be changed according to the crossreference table.

After positioning, screw Pin #557 and Setscrew #936 respectively into the through-holes.

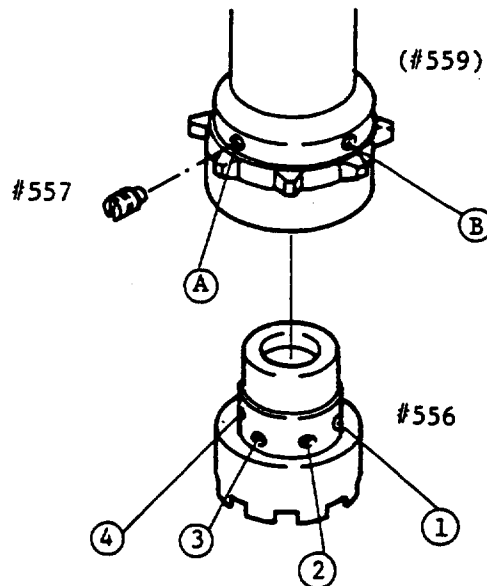

Deviation (mm)	Alignment
-2.70 ↔ -2.41	(A) → (3)
-2.40 ↔ -1.72	(B) → (4)
-1.71 ↔ -1.03	(A) → (4)
-1.02 ↔ -0.35	(B) → (1)
-0.34 ↔ +0.34	(A) → (1)
+0.35 ↔ +1.02	(B) → (2)
+1.03 ↔ +1.71	(A) → (2)
+1.72 ↔ +2.40	(B) → (3)
+2.41 ↔ +2.70	(A) → (3)



3-13 Film-advance Mechanism Check and Adjustment

3-13-1 Film-advance

Check the film-advance lever for the series of shorter film-advancing and the smooth stroking.

See if the film-advance lever cannot be stroked unless the shutter is released.

3-13-2 Spool

Check the spool for the smooth rotation and the anti-reverse device (Reverse stopper claw #418).

The vertical play of the spool to be 0.2 - 0.3mm.

The spool friction can be measured in the same procedure as the F and the F2. For adjustments, replace FA1-577.

Standard spool friction: 200 - 330g

3-13-3 Spacer #553

With film-advance lever fully stroked with finger (Shutter cocked condition), check the clearance between Stopper #537 and Spacer #553 when rotating the sprocket as far as it will go in the direction of film-rewind.

Standard: 0.1 - 0.3mm

Adjustment is made by loosening screw ⊕ #857 x 2 and re-locating #553. After adjusting, apply adhesive #616 onto #857. Do not overtighten #857. (Adjustment will be soon simplified by installation of eccentric pin.)

3-13-4 Sprocket

Check the sprocket for play of the tip of its tooth. (Standard: 0.4 - 0.8mm)

The sprocket should reverse smoothly with the rewind button set to "rewind position".

3-13-5 Rewind Button

Check the rewind button for proper operation. It should be released by the film-advance lever stroking. The stroke of the rewind button should measure $3.1 \pm 0.3\text{mm}$ from the surface of the bottom cover.

(The full stroke to be $3.8 \pm 0.2\text{mm}$)

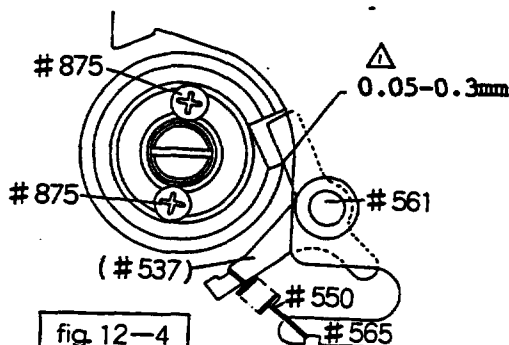

fig. 12-4

3-14 Coupler, multi-exposure

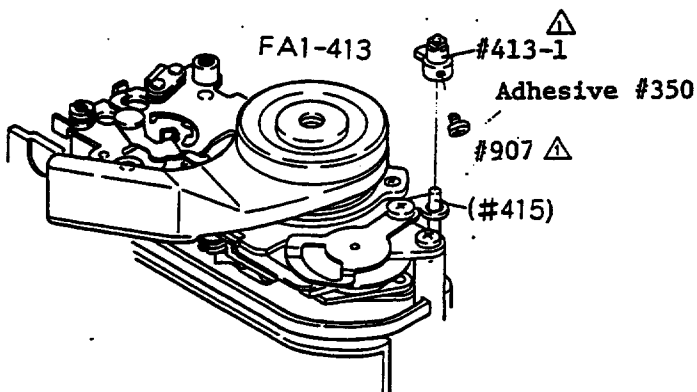

fig. 14-1

Body, wind-side, top

Body die-casting

Coupler FAI-413

Screw ~~#904~~, \oplus #907

- 1) Provide thrustward play of 0.05 - 0.21mm.
- \triangle 2) Tighten the setscrew, with Multi-exposure lever axle #415 installed.

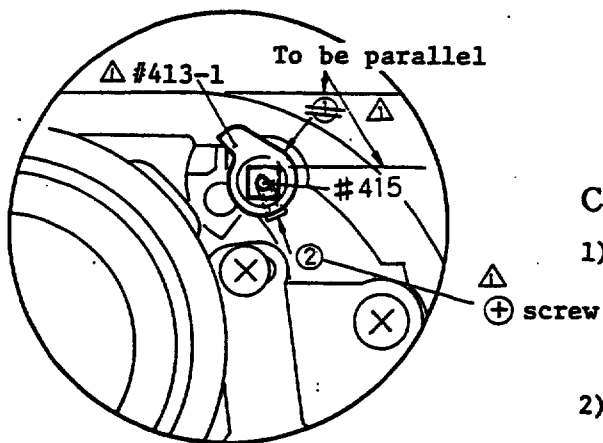

fig. 14-2

Coupler FAI-413

Fig. 14-3 shows where Spring #592 engages.

Check Points

- 1) Turn FAI-413 to set Cam #591. Then see if #591 will not be freed when the film-advance lever starts being stroked.
- 2) Check FAI-413 for proper setting and releasing. (See fig. 14-4.)

Adjustment can be made by replacing FAI-413.

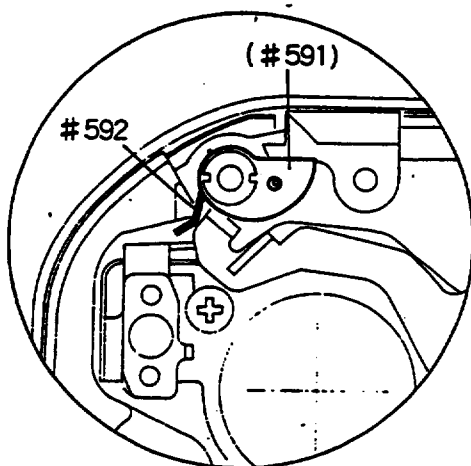

fig. 14-3 Spring #592

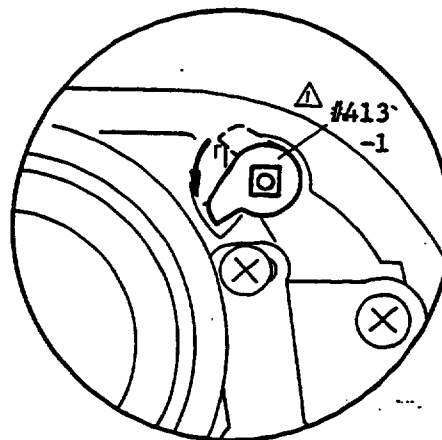

fig. 14-4

3-15 Mirror Cocking Lever

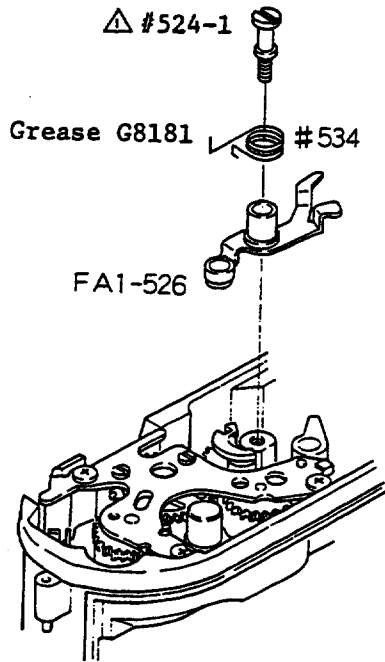

fig. 15-1 Body, wind-side, bottom

Body die-casting

Mirror cocking lever FA1-526
Spring #534 (See fig. 15-2)

Use G8181 to lubricate the side face of Roller #527.

Set the camera body to the shutter-cocked condition.

When installing, place #527 against the side of (#547) under-neath (#543).

Axel ⊖ #524-1 ⊕

Surplus Movement of FA1-526

Standard: 0.4 - 0.8mm

Fig. 15-3 shows how to measure the surplus movement of FA1-625 at its maximum working distance for mirror cocking.

Adjustment can be made by changing the three levers of different size.

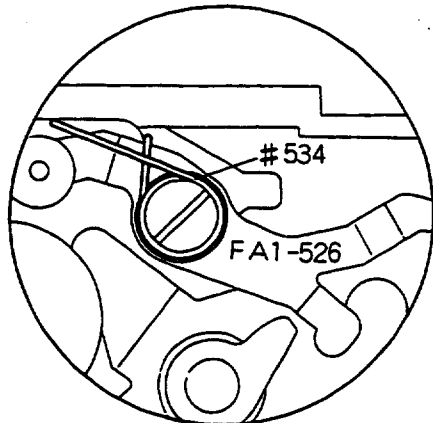

fig. 15-2

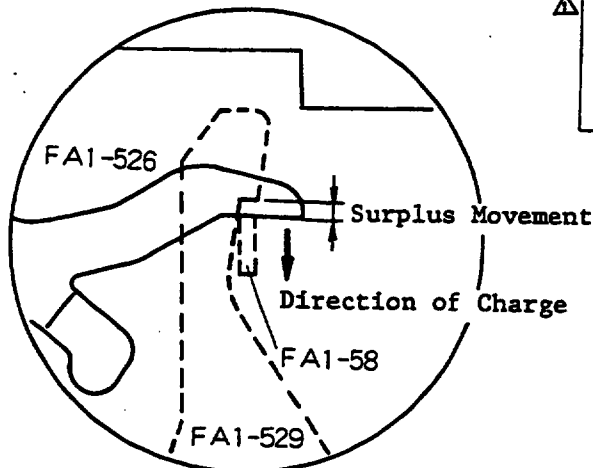

fig. 15-3

P/N	Mark	Surplus movement
⊕ FA1-625	Nil	
⊕ -526	Black	-0.2mm ⊕
FA1-618	Green	+ 0.4 mm
FA1-619	Red	-0.4 ⊕

3-16 Shutter-release Button Stroke

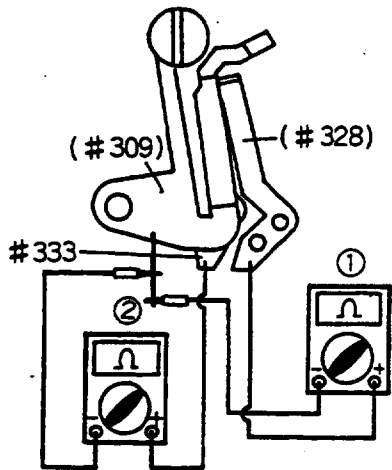

fig. 16-1 Connecting testers

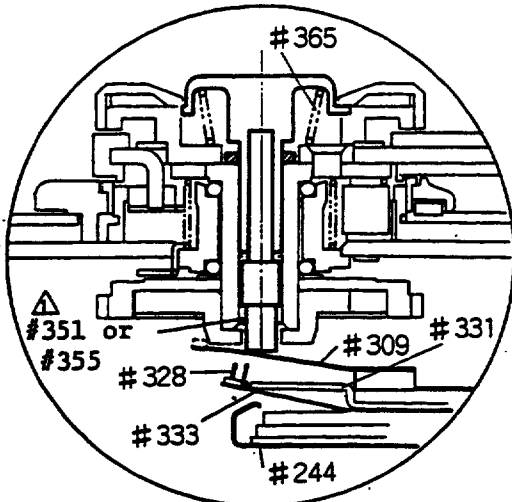

fig. 16-2 Shutter-release button; sectional view

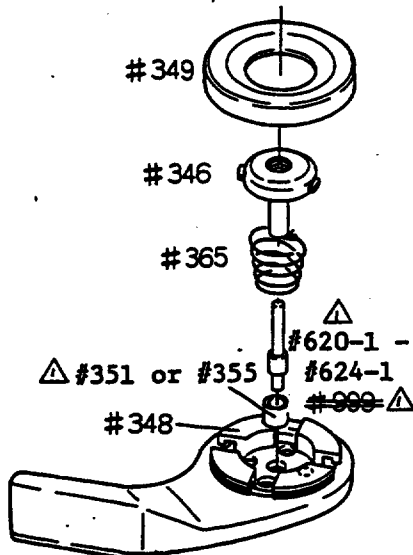

fig. 16-3 Shutter-release button

Shutter-release button stroke is changeable by adjusting the timings of liquid crystal display and the release-magnet's operation.

Checking Procedures by Using a Tester

- 1) Tools required: Micrometer J15189
Tester J9006

- 2) How to connect a Tester

As depicted in fig. 16-1, connect two testers to Contact (#328), Release contact (#333), camera body respectively to check the ON/OFF timing of the release switch.

- 3) How to check

Remove Cover ring #349 and Screw J15189 on Stopper #348. Setting the position where the tip of J15189 just contacts the head of the release button to "Station 0", measure and check the following strokes. (See fig. 16-3.)

Release-button Stroke

Stroke	Standard:mm	Tester ①	Tester ②
Normal condition		OFF	OFF
First stroke	0.5 ± 0.1	ON	OFF
Second stroke	1.2 ± 0.2	ON	ON
Play of Stroke	$0.2 - 0.4$	ON	ON

- a) First stroke: Interval between the starting point and the point where Spring (#309) just touches Power switch contact (#328) when Release button #346 is slightly depressed. (Liquid crystal display will immediately appears.)

Identification groove

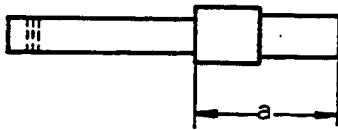

fig. 16-4 Release Shaft

b) Second stroke: Interval between the end of first stroke and the point where the power switch contact just touches Release contact (#333) when the release button is further depressed. The Release-magnet operates to release the shutter.

c) Play of stroke: Interval from the end of second stroke to the limit when the release button is fully depressed.

4) Adjustments

- First stroke: Replace Release shaft with another one. Four replacement parts are available as listed below.
- Second stroke: Bend Retainer #334.
- Play of stroke: Add Washer #999.

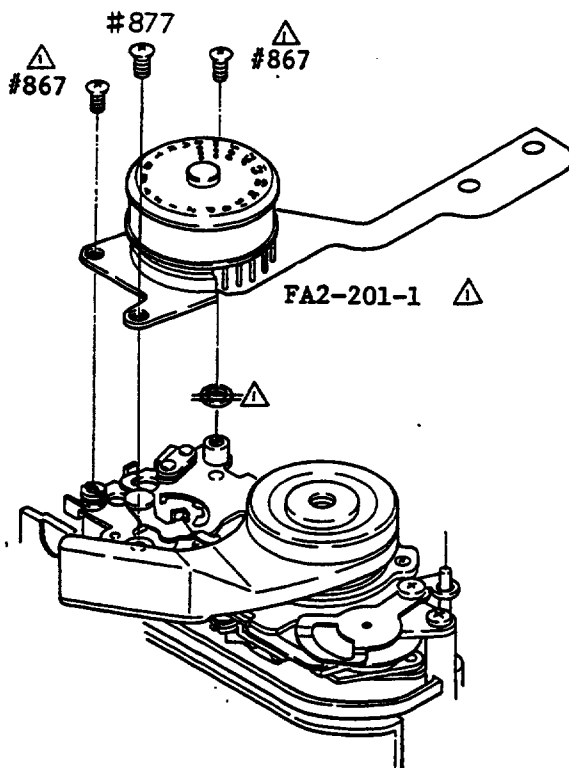

fig. 17-1

Body die-casting, wind side

P/N	Dimension a	Identification groove
△ #621-1	6.4	1
△ #622-1	6.5	2
△ #620-1	6.6	nil
△ #623-1	6.7	3
△ #624-1	6.8	4

Note: #620 is standard.

3-17 Unit, shutter-speed selector

Body die-casting

Unit FA2-201-1 △
Screw ⊕ #877
Screw ⊕ #867x2 △

Before installation, set the shutter-speed dial to "T" (Time Exposure).

- After installation, check to see if "Time Exposure" is securely done.
- Check that "Time Exposure" is cancelled (i.e. Closing curtain starts traveling) immediately before the shutter-speed dial is set back to X or B click-stop setting.

3-18 FPC Installation

Prior to FPC installation, temporarily assemble Front plate unit to Body die-casting and check the operation referring to (19) & (20) (p.p. A19 - A20).

3-18-1 Precautions on FPC

- 1) Do not handle roughly; Ceramic 1005 and the infrared-soldering portions are prone to separate.
- 2) When installing, be sure to use cotton gloves.
- 3) Be sure to earth the soldering iron to prevent damage to IC by leak current.
- 4) Do not touch variable resistors with bare hands.

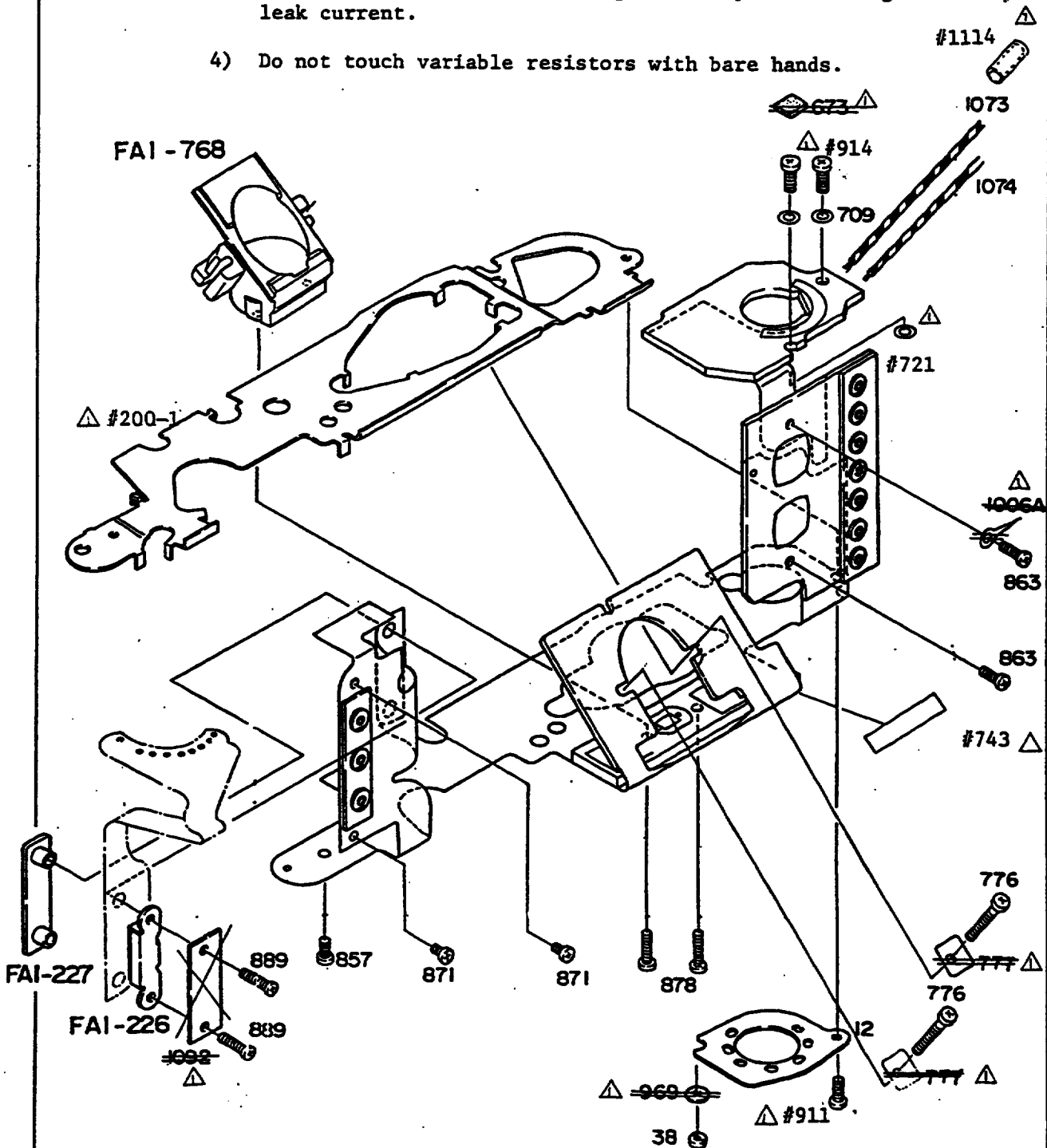

3-18-2 Installation

Install Holder FA1-768 into FPC FA4-1001-1 and secure with Screw ⊕ #878x2

↓
Camera body

↓
Ceramic, exposure information #1005

Washer #709 x 2

Screw ⊕ #914x2 △

- 1) Do not overtighten screws; Ceramic is prone to crack.
- 2) Use care not to separate the infrared-soldering joints.

↓
Quartz oscillator #1006-1

Screw ⊕ #863 x 2

~~Lug, ground #1006A (Unnecessary if FPC is equipped with ground terminal) △~~

↓
Holder FA1-768

As illustrated, route Lead wire #1079 (black) through the notch of Holder for soldering.

↓
FA connector #771

Screw ⊕ #776 x 2

↓
Resistor block #1009

Screw ⊕ #871 x 2

↓
FPC, bottom

Position aligning two soldering hole on FPC with Switch B #602 and MD switch #37 respectively.

↓
Screw ⊕ #857

↓
Cover, MD connector #12

Screw ⊕ #911 △

~~Washer #969 △~~

Nut #38 (Tool required; J11122)

↓
Base plate FA1-227

- 1) Prior to installation, clean the mating surfaces of FPCs.
- 2) Mate the pressure-contacted portion of shutter-speed selector (FPC-4 #1032) with that of FPC-1 #1001, then position them aligning holes of FPCs with Shafts #228.

↓
Holder FA1-226

Install, being careful to its direction. See Fig. 18-1.

~~Circuit board B FA1-1092 △~~

↓
Screw ⊕ #889 x 2

3-18-3 Lead Wire Soldering

- 1) Lead wire #1061, battery plus (Red)
- 2) Lead wire #1064, battery minus (Black)
- 3) Terminal, film-advance completion switch
- 4) Terminal, MD switch
- 5) Lead wire #1069, release switch (Gray)
- 6) Lead wire #1062, power switch A (Yellow)
- 7) Lead wire #1063, power switch B (Gray)
- 8) Terminal, closing curtain magnet minus
- 9) Terminal, closing curtain magnet plus
- 10) Terminal, trigger switch
- 11) Terminal, closing curtain switch

Note: FPC should be firmly installed, free from detaching.

- 12) Lead wire #1084, B unit base (Blue)
- 13) Lead wire #1085 (Red)
- 14) Lead wire #1079, data contact (Black)

△ Lead Wire Soldering (FA4-1001-1)

- 11)
- 12) Lead wire #1071 (white)
- 13) Lead wire #1084 (blue)
- 14)

3-18-4 Liquid Crystal Display Operation Checking

After completing soldering mentioned above, check the operation of LCD by using tool battery or battery.

Tool: J15148-1 (Modify the mount base referring to RJ information issued separately)

Shutter-speed dial setting		Check Point	
Manual	2000 - 1/2	M2000 - M2	Correct LCD should appear in accordance with setting.
	1 sec. - 8 sec.	M1 - M8	
	B, T	M	
Auto	A	8	
Correct exposure display		When Lead wire #1078 (brown) is touched to the mating surface with #706 of Ceramic #1005, the display should change as follows: -8- → +2000	

3-19 Body Assembly & Front Plate Assembly

As for Front plate assembly, refer to P. (S5)

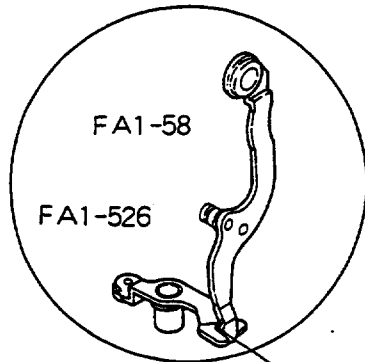

fig. 19-1

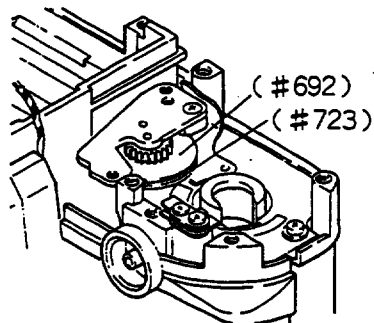

fig. 19-2

Body assembly

Before installation, set the shutter unit in the cocked condition. Also loosen Axle #524.

Front plate assembly

- 1) Apply G8181 to the mating surfaces of Vertical lever FA1-58 and Mirror cocking lever FA1-526.
- 2) Make sure that Aperture coupling thread (#732) is rolled around the groove of Winding roller (#692).
- 3) Insert the driver from the bottom of camera body (Area shaded in fig.20-3) and disengage Quick-return lever #529 from Vertical lever #58, then install Front unit base in place so that Mirror cocking lever engages with Vertical lever #58 as shown in fig. 20-3.

Screw ⊕ #909 x 2, ⊕ #892 x 2, ⊕ #882x6

Before tightening, closely fit the left lower part of Front unit base to Body die-casting (in the direction of arrow in fig. 20-4). Tighten screws in the sequence numbered in fig. 20-4. After installation, check the unit (referring to p. A22).

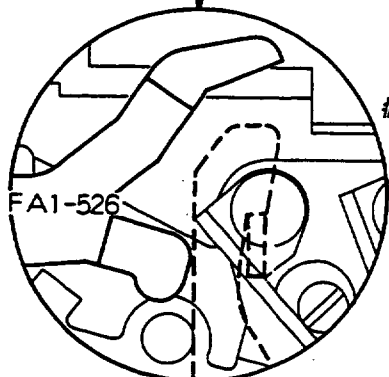
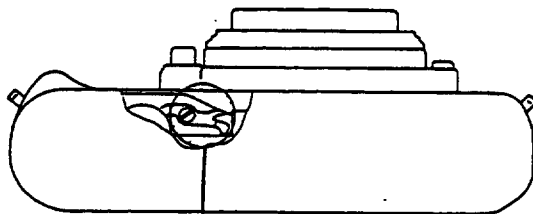

fig. 19-3

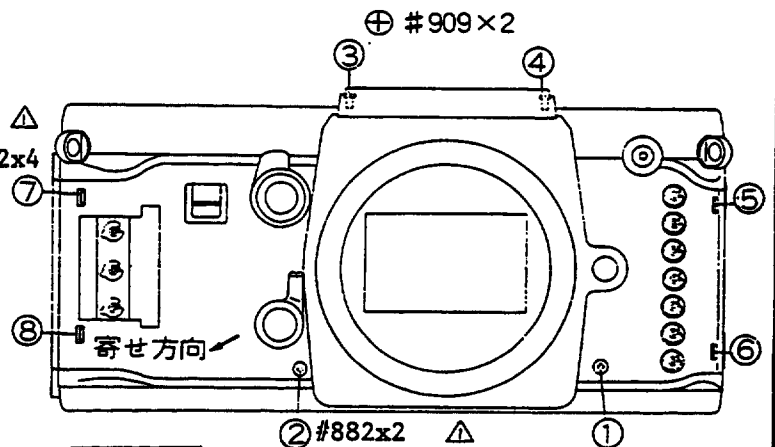

fig. 19-4

Front plate assembly Fixing Sequence

3-20 Checking Procedures after Front Plate Assembly Installation

3-20-1 Reflex-mirror Operation

The reflex-mirror should be securely cocked.

Apply finger-pressure slightly onto the reflex-mirror and depress the shutter-release button, then gradually raise the reflex-mirror by releasing finger-pressure. With this method, check the reflex-mirror for smooth up and down movement.

3-20-2 Mirror-rising Position

In the same manner mentioned on item 1), check the interval between the top surface of the reflex-mirror and Mirror-Stopper #138 immediately when the opening curtain travels.

Standard: 7.3 - 9.3mm

For adjustment, bend the tip of Signal lever #64.

3-20-3 Mirror Lock-up Position

After mirror locking-up, release the shutter a few times to check the clearance between the reflex-mirror and the mirror stopper.

Standard: Less than 0.3mm

Adjustment is possible by bending Lever #62.

3-20-4 Stop-down(Depth-of-field preview)Button Operation

Operation should be secure and smooth. Aperture lever should securely move to the point as specified. For other items, the standard is the same as that of F2. For Adjustment, refer to p. S6.

3-20-5 Mechanical Shutter Release Operation

After film-advance operation, when the mechanical release knob is turned, both the reflex-mirror and the shutter should securely operate. When the mechanical release knob is returned, it should firmly click into place.

3-20-6 Lens-release Button Operation

Operation should be smooth. Release-pin should protrude 0.7 - 1.2mm above the bayonet surface.

3-20-7 Body Flange Back

Same as that of the FE. Refer to the Repair Manual of FE.

3-21 Lead Wire Soldering from Front Plate Assembly

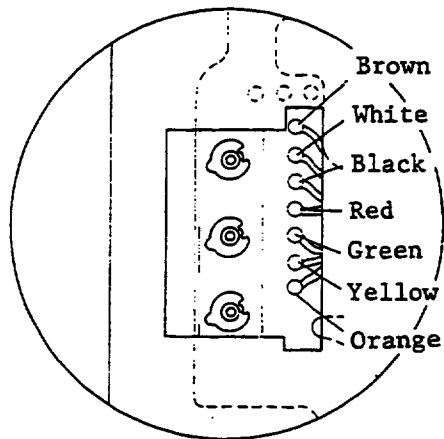

fig. 21-1

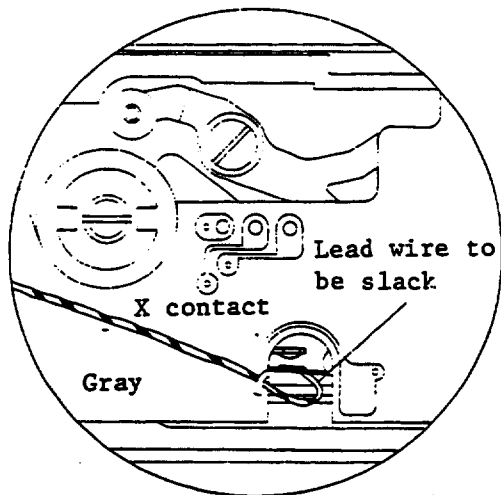

fig. 21-2 Lead wire X contact

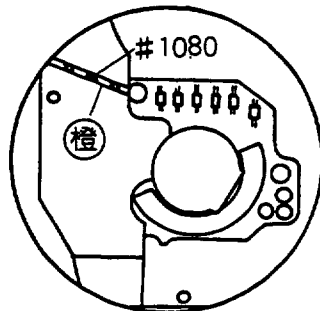

fig. 21-3

Tool: Soldering Iron

Points to be soldered

- 1) Lead wire B #1066,
self-timer LED (Brown)
- 2) Lead wire A #1065,
self-timer LED (White)
- 3) Lead wire, release magnet minus
(Black)
- 4) Lead wire, release magnet plus
(Red)
- 5) Lead wire #1083, memory switch
(Green)
- 6) Lead wire A #1081,
shutter switch (Yellow)
- 7) Lead wire B #1082,
shutter switch (Orange)
(fig. 22-1)
- 8) Lead wire #1077, X contact (Gray)
(fig. 22-2)
- 9) Lead wire #1080, AF contact (Orange)

3-22 Unit, rewind shaft

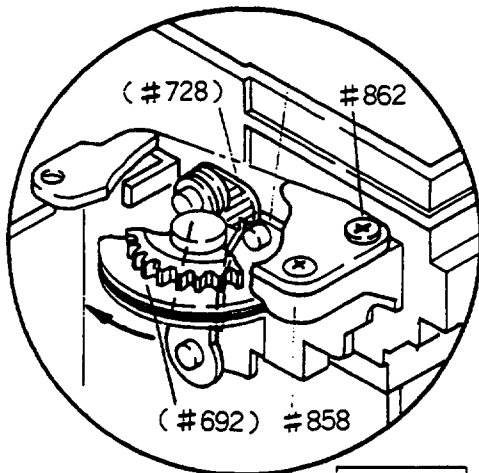
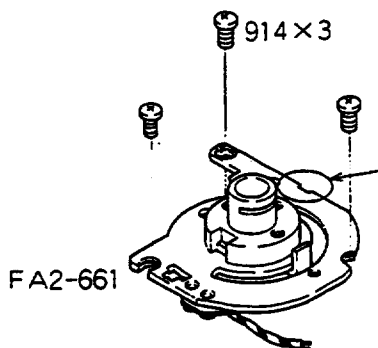

fig. 22-1



FA2-661

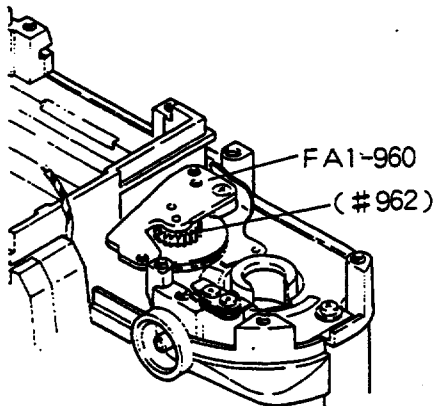

fig. 22-2

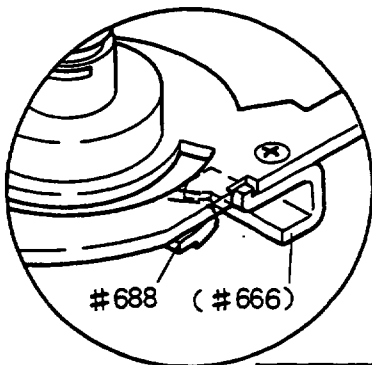

fig. 22-3

Maximum aperture compensation system is the same as that of Nikon FE and FM. The resistance value of FRE remains unchanged between F/1.4 and maximum aperture compensating position (F/1.6). The value changes immediately when the aperture ring is rotated from F/1.6 toward the minimum aperture.

Tool required: J18065

- Body
- 1) Mount Tool Lens J18065 onto the camera body and set the aperture ring to F/1.6
 - 2) Rotate Winding roller (#692) clockwise until it contacts stopper (a part of #55; see fig. 22-1.)

Unit FA2-661, Screw ⊕ #914 x 3
 Check Brush gear #688 and Winding roller (#692) for proper engagement.
 If improperly engaged, adjust by re-locating Unit base FA1-690.
 Screw ⊕ #858, ⊕ #862 (fig.22-1)

Maximum F.No. Checking

- 1) Brush gear FA1-688 should securely starts rotating when the aperture ring is rotated from F/1.6 to F/2. Malfunction may result if FA2-661 is improperly positioned. Adjustment is possible by re-locating FA2-661.
- 2) Brush gear should securely come in contact with Stopper (#666) when the aperture ring is reversed from F/2 to F/1.6. (fig. 22-2) Adjustment can be made by bending Stopper. (fig. 22-3)

3-23 Display Block, exposure information

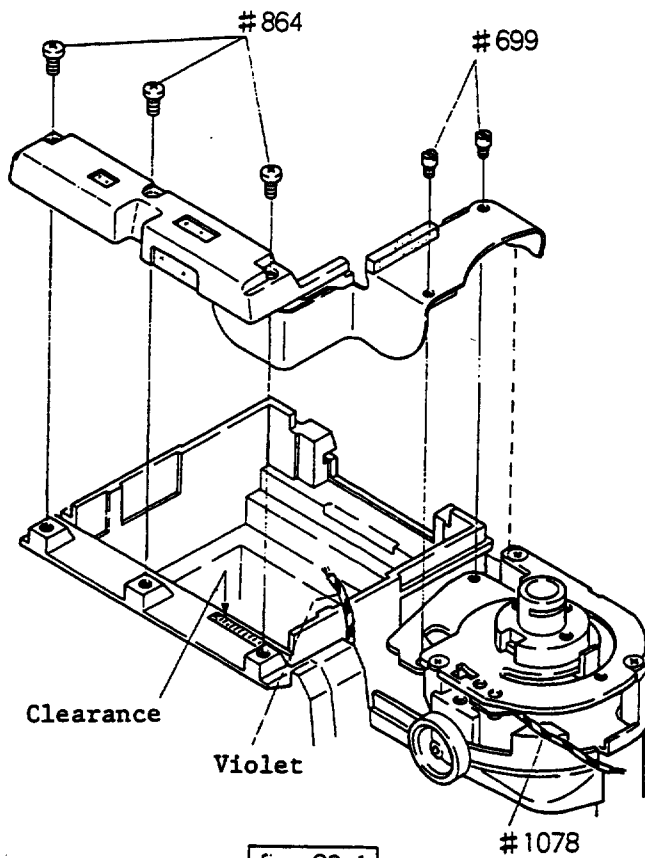

fig. 23-1

Camera body

Locate Lead wire B #1076 (Violet) as depicted in fig. 24-1.

Display block, FAI-132

Insert FPC between Front plate and Body die-casting as per fig. 23-1.

Screw ⊕ #864 x 3

Screw ⊖ #699 x 2

Soldering

1. Lead wire #1078, FRE brush (Brown)
 2. Lead wire B #1076, synch signal (Violet)
- (See fig. 23-2.)

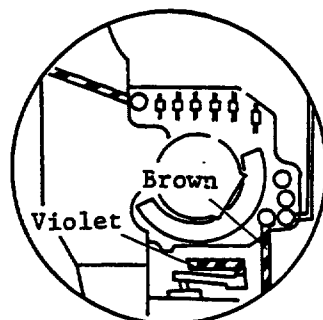

fig. 23-2

3-24 Electrical System Operation Check

After completing FPC, LCD installation, install new batteries to check the following electrical operation.

3-24-1 Power Switch(Meter ON/OFF switch)

When the shutter-release button is depressed slightly, liquid crystal display should appear. Display should disappear in approx. 16 sec. after the finger is lifted off the button.

3-24-2 Shutter-release

When the shutter-release button is depressed further down, the shutter should be securely released.

3-24-3 Self-timer

With the protrusion of Disk #211 set to the self-timer setting, when the release button is depressed, self-timer LED should go on and off at a 2 HZ rate for first 8 seconds, then it should also go on and off at a 8 HZ rate for 2 seconds before the shutter is released.

3-24-4 Shutter-speed Change-over

With the shutter-speed dial set to "Auto", when the light-intensity into the camera body is changed, the shutter speed should also change.

Shutter speed should vary with manual shutter-speed setting.

Note: Before checking, if the counter switch remains ON, advance the frame counter more than 3 frames.

3-24-5 Liquid crystal Display(LCD)

When the shutter-speed dial is set to manual shutter speed setting ranged from 1/2000 to 8 sec., correct liquid crystal display in accordance with the setting should appear. (e.g. M2000 - M8)

With the shutter-speed dial set to "Auto", when the aperture ring is rotated or the camera's lens-mounting ring is covered by the hand, liquid crystal display should change.

When the shutter-speed dial is set to "B" and "T", the following display should appear respectively.

B : M⁻ T : M⁻

3-25 Top Cover, rewind side

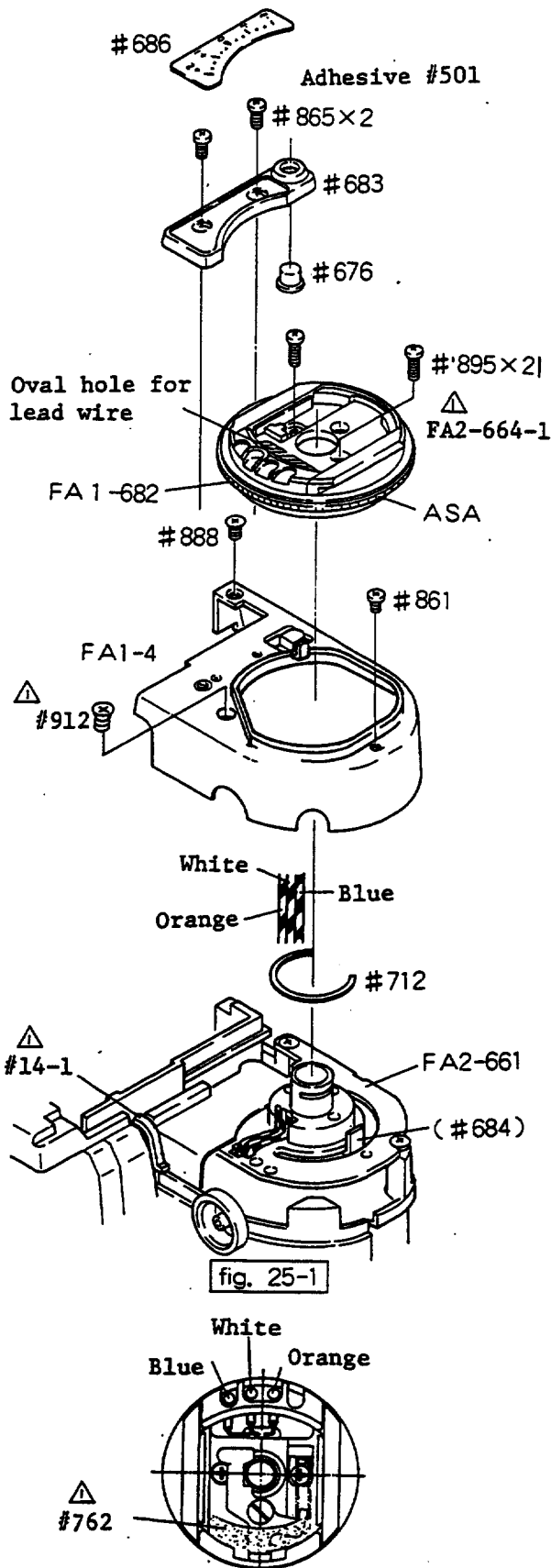

Camera body

Top cover, rewind side FA1-4
Screw ⊕ #888, ⊕ #861 ⊕ #912x1 △

Lead wire fixing with #712

- 1) Lead wire #1073 (Blue)
 - 2) Lead wire #1074 (White)
 - 3) Lead wire A #1075 (Orange)
- Position three lead wires as depicted in fig. 25-1 and fix to Unit FA2-661 with Spring #712.

Shoe FA2-664-1 △

- 1) Pass the above three lead wires through the oval hole.
- 2) At installation, engage the protrusion of FRE holder (#684) with the slot of ASA dial.

Screw ⊕ #895 x 2

- 1) Lift ASA dial ring and rotate it to check that the ring rotates smoothly and that it locks into place with a click.
- 2) Also check that ASA film speed can be set at both rotation limits (ASA12 & ASA6400)

Lock button #676

Holder #683, Screw ⊕ #865 x 2

- 1) Temporarily install Exposure compensation scale #686 and rotate Exposure compensation knob FA1-682 to both limits (+2 and -2 directions) to check that the scale is equally located.
- 2) Check Lock button #676 for smooth operation.
- 3) Adjustment is possible by re-locating #683.

Exposure compensation scale #686
Apply pliobond.

Solder three lead wires referring to
fig. 25-2.

3-26 Counter Switch Adjustment Procedures

Tool required: Tool camera back J15187

Attach Tool J15187 or camera back to the camera body and stroke the film-advance lever to operate the frame counter for ON/OFF timing check of the counter switch.





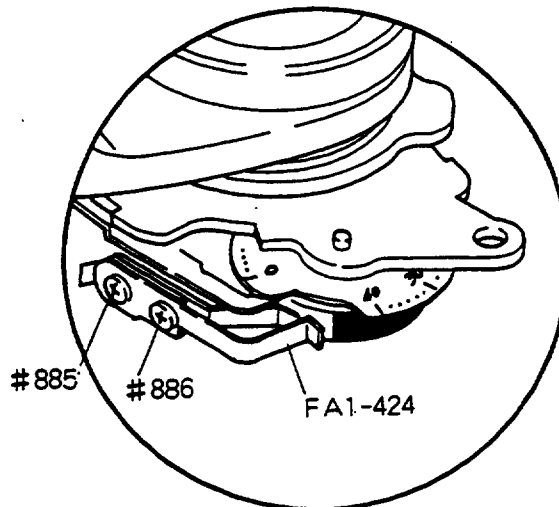

frame		S → 0	0 → 1
counter switch		ON	OFF
Mode			
Auto		80	Set shutter speed
M	2000 - 125	M80	2000 - 8"
	60 - 8s	M60 - 8"	

For adjustment, loosen screw (⊕ #885) and re-locate Unit FA2-381.

Note: Screw #885 ... left-handed

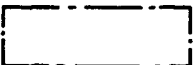
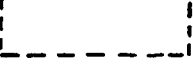

3-27 Shutter & Meter Accuracy Adjustments

Mark	Name	Meaning
	Terminal	Name of check/adjustment procedures
	Input	Preparation Check Measurement
	Judgement	To see if the value conforms to the standard
	Treatment	Adjustment procedures
	Connector	To be connected to "◻"
	Connectee	To be connected from "△"
	Arrow	Work sequence

3-27-1 Checking Sequence

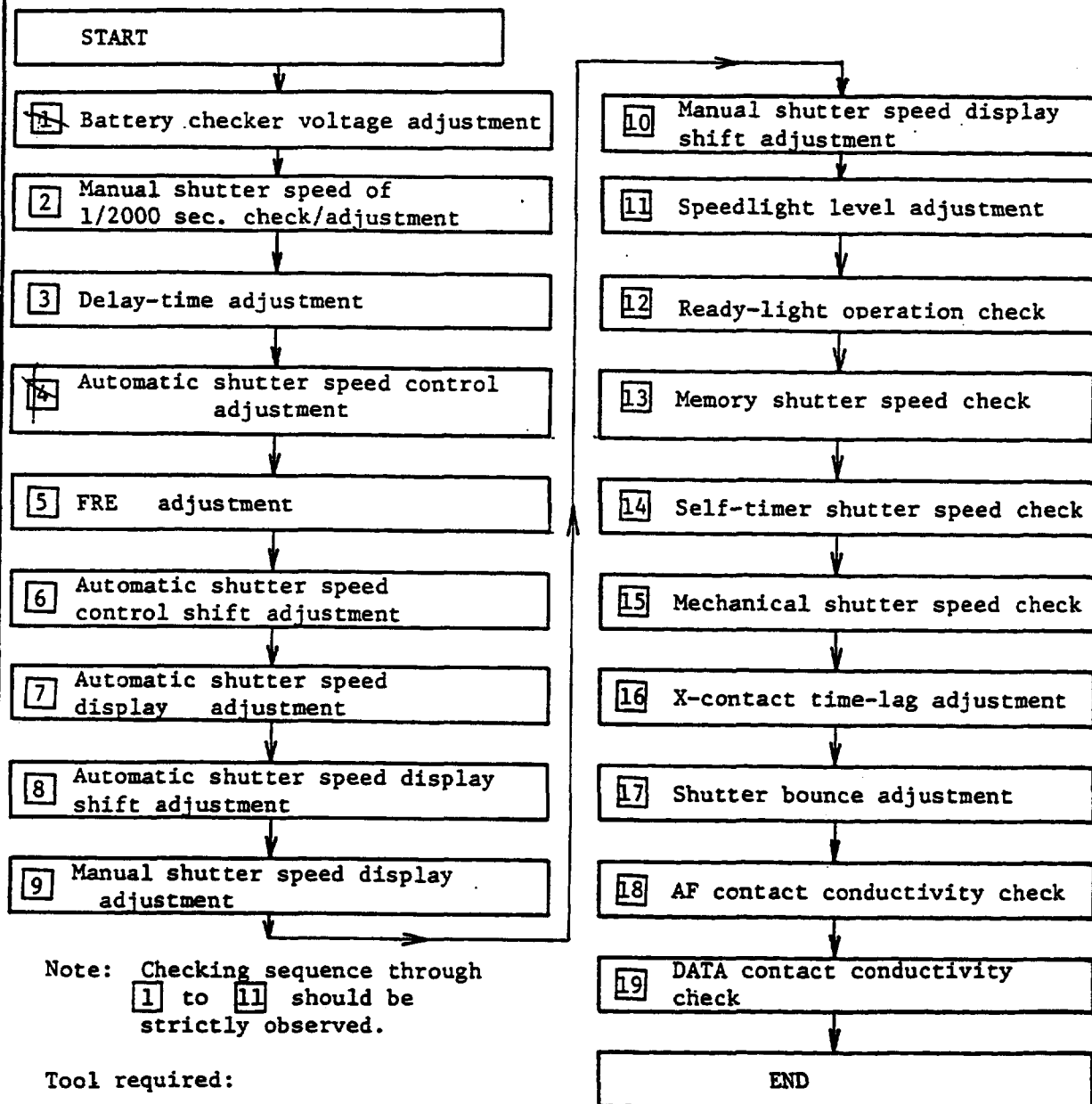

Digital multi-meter J9032, etc.	DC regulated power supply J9001-1, etc.
Shutter tester J18022-1, J19033	Tool camera back J15187
Tool lens J18041-1	Dummy strobe J18077
Driver J15188	Standard reflector J15196
Finder cover J15191	DAS conductivity check tool J18078

- (1) When using shutter tester J18022-1, set the mode selector of shutter curtain travel to the horizontal direction.
- (2) It is impossible to check the auto/manual shutter speeds of 1/1000 and 1/2000 with J18022-1, because the slit of J18022-1 is too broad.
- (3) When checking, attach Tool camera back J15187 to the camera body and advance the frame counter more than 3 frames (Counter switch...OFF).
- (4) Rotational direction of VR mentioned in this section indicates the direction viewed from the front side of the camera body (camera's lens-mount side).

3-27-2 Location of Variable Resistor for Adjustment

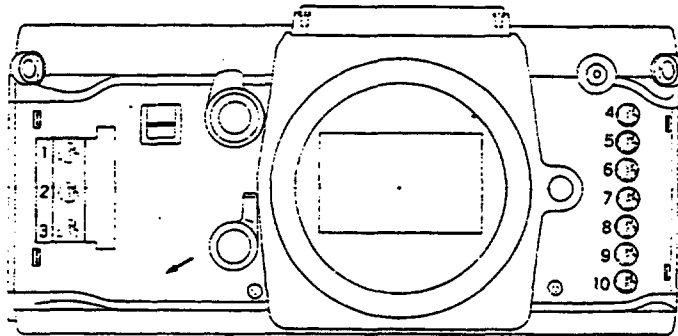

- VR1: Automatic shutter speed control f adjustment
- VR2: Battery checker voltage adjustment
- VR3: Speedlight level adjustment
- VR4: Automatic shutter speed display f adjustment
- VR5: Automatic shutter speed display level adjustment
- VR6: Manual shutter speed display shift adjustment
- VR7: Automatic shutter speed control shift adjustment
- VR8: FRE f adjustment
- VR9: Manual shutter speed display adjustment
- VR10: Delay-time adjustment

3-27-3-1 Battery Checker Voltage Adjustment

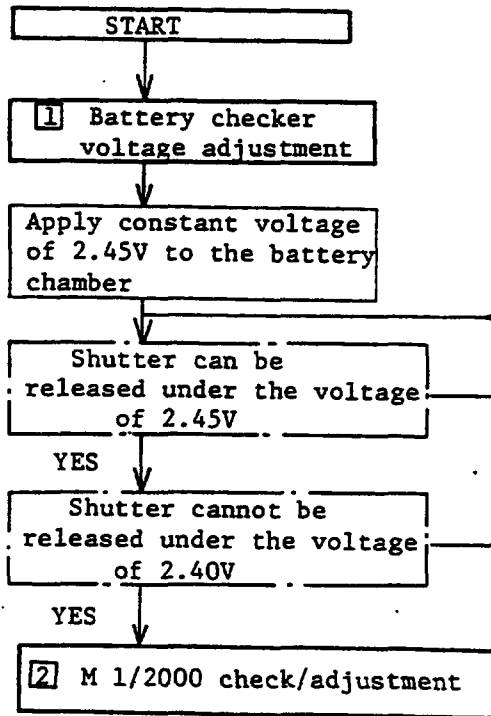
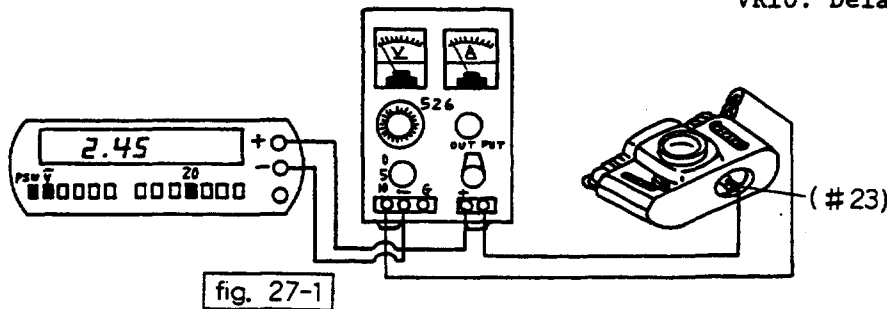

3-27-3 Flow-chart

Connect Digital Voltmeter to DC regulated power supply and the camera body respectively as depicted in fig. 27-1.

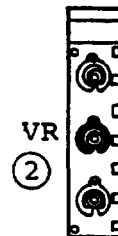

3-27-3-2 Manual Shutter Speed of 1/2000 sec. Check/Adjustment

2 M 1/2000 check/adjustment

Check of manual shutter speed of 1/2000 sec.

1

Tolerance to be 0.35 - 0.66ms

YES

NO

Check of the time required for shutter curtain's travel at 1/2000

Tolerance to be 10.0 ± 0.5ms

NO

YES

(b) Re-locate Spring #237

Tolerance to be 0.35 - 0.66ms

YES

NO

(c) Rotate Pin (#296)

Tolerance to be 0.35 - 0.66ms

YES

NO

(d) Rotate Eccentric pin (#283)

3 Delay-time adjustment

- (a) To shorten shutter speed.
- To lengthen shutter speed.

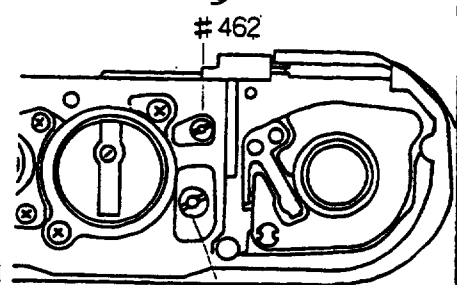

Camera Back #467
fig. 27-2

(a) Rotate Tension gears #467 & #462

- (b) Prior to adjustment, remove Unit base FA2-201.

Spring engagement	Shutter speed
② → ③	shortened (0.5 → 0.3ms)
② → ①	lengthened (0.5 → 0.7ms)

Note: 2... Standard position



fig. 27-3

- (c) Prior to adjustment, remove Unit FA2-381. Clearance to be 0 - 0.2mm between Pin (#296) and Hook (#292) (For stable shutter speeds 1/500 & 1/1000) After adjustment, apply adhesive #350.

- (d) 1) Take out Front unit base and remove adhesive agent on Eccentric pin (#283).
- 2) Remove Unit FA2-201, then you can easily make adjustment with set driver (#2) through the access hole on Unit FA2-231.
- 3) After adjustment, apply adhesive #616 onto Pin.

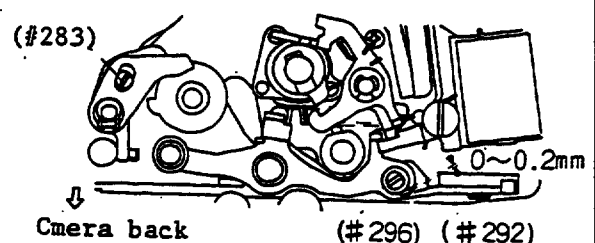
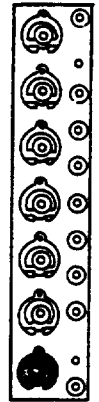
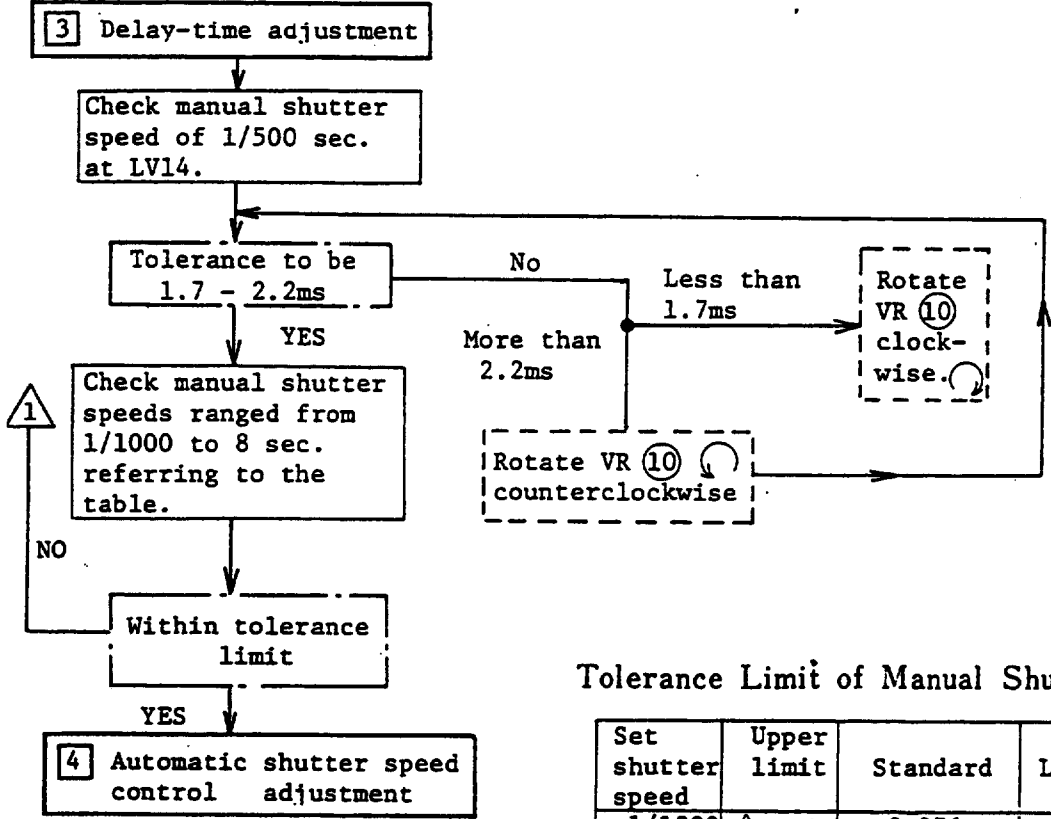

fig. 27-4

3-27-3-3 Delay-Time Adjustment

Delay-time is to adjust the period from trigger switch OFF-time to trigger-OFF signal transmitting time in order to harmonize the mechanical system with the electrical system.



Tolerance Limit of Manual Shutter Speed

Set shutter speed	Upper limit	Standard	Lower limit
1/1000	△ 1.41	0.976	0.68 △
1/500	2.66	1.95	1.43
1/250	5.34	3.91	2.86
1/125	9.62	7.81	6.34
1/60	19.2	15.6	12.7
1/30	38.4	31.2	25.3
1/15	76.9	62.5	50.8
1/8	153	125	102
1/4	308	250	203
1/2	616	500	406
1s	1231	1000	812
2s	2.46s	2000	1.62s
4s	4.92s	4000	3.25s
8s	9.85s	8000	6.50s

Note: Exposure balance between the middle of the frame and the both frame edges to be ± 0.2EV.

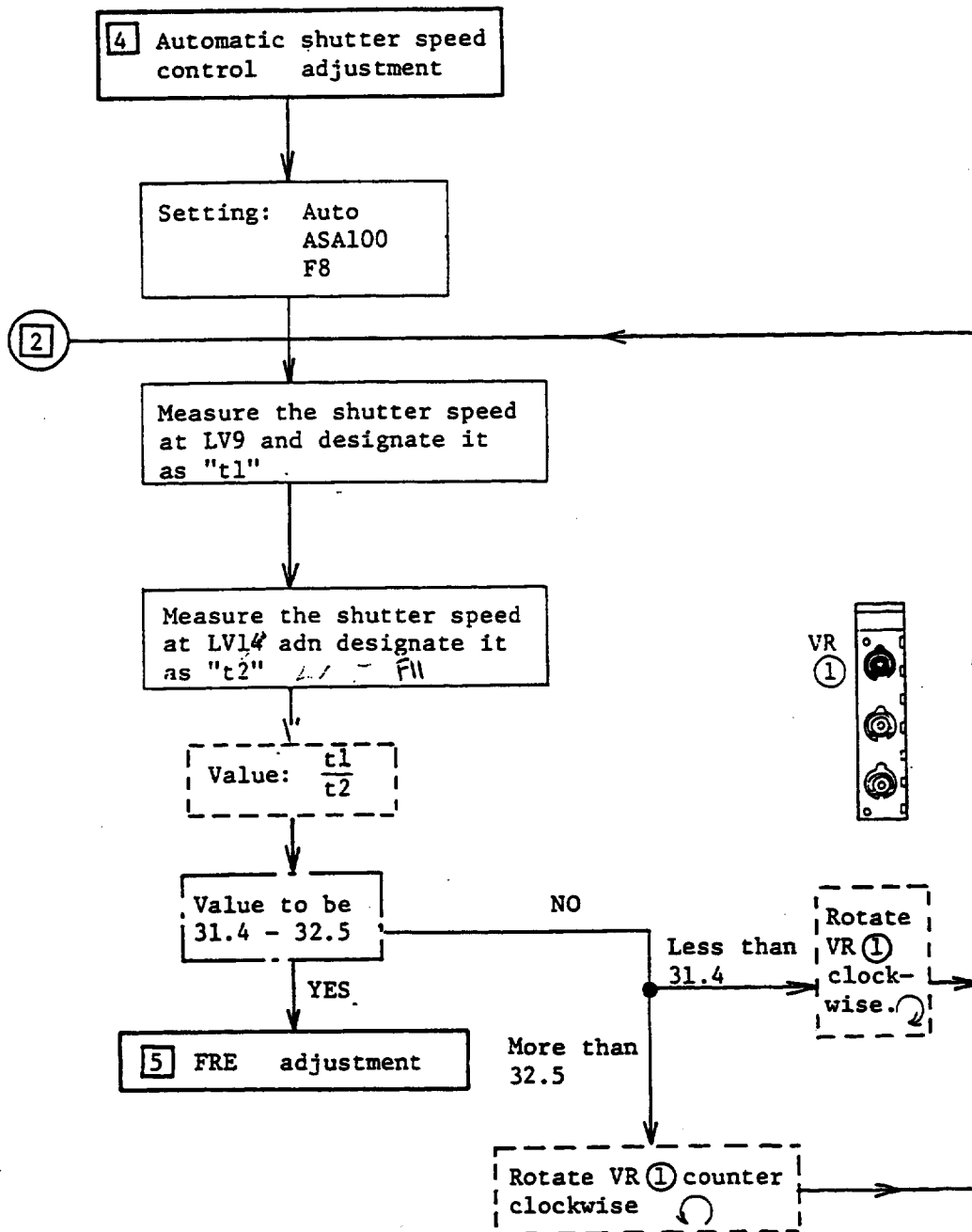
3-27-3-4 Automatic Shutter Speed Control γ Adjustment

Note: 1) As for the shutter speeds of "t1" and "t2", measure 5 - 10 times, then take the average respectively.

2) Value $t1/t2$ has much effect on the automatic shutter speed display accuracy and thus it should strictly conform to the standard: 31.4 - 32.5.

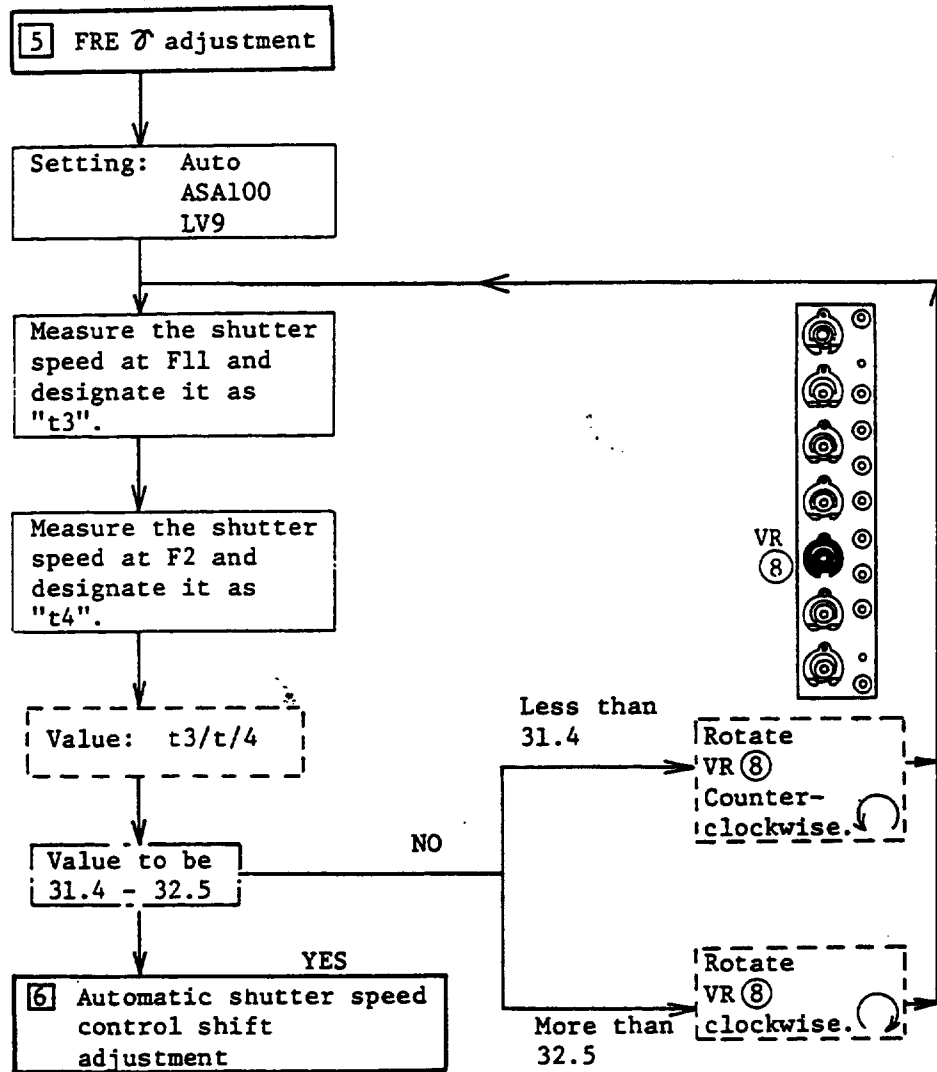
3-27-3-5 FRE γ Adjustment

Note: Value $t3/t4$ has much effect on the automatic shutter speed display accuracy and thus it should strictly conform to the standard: 31.4 - 32.5.

3-27-3-6 Automatic Shutter Speed Control Shift Adjustment

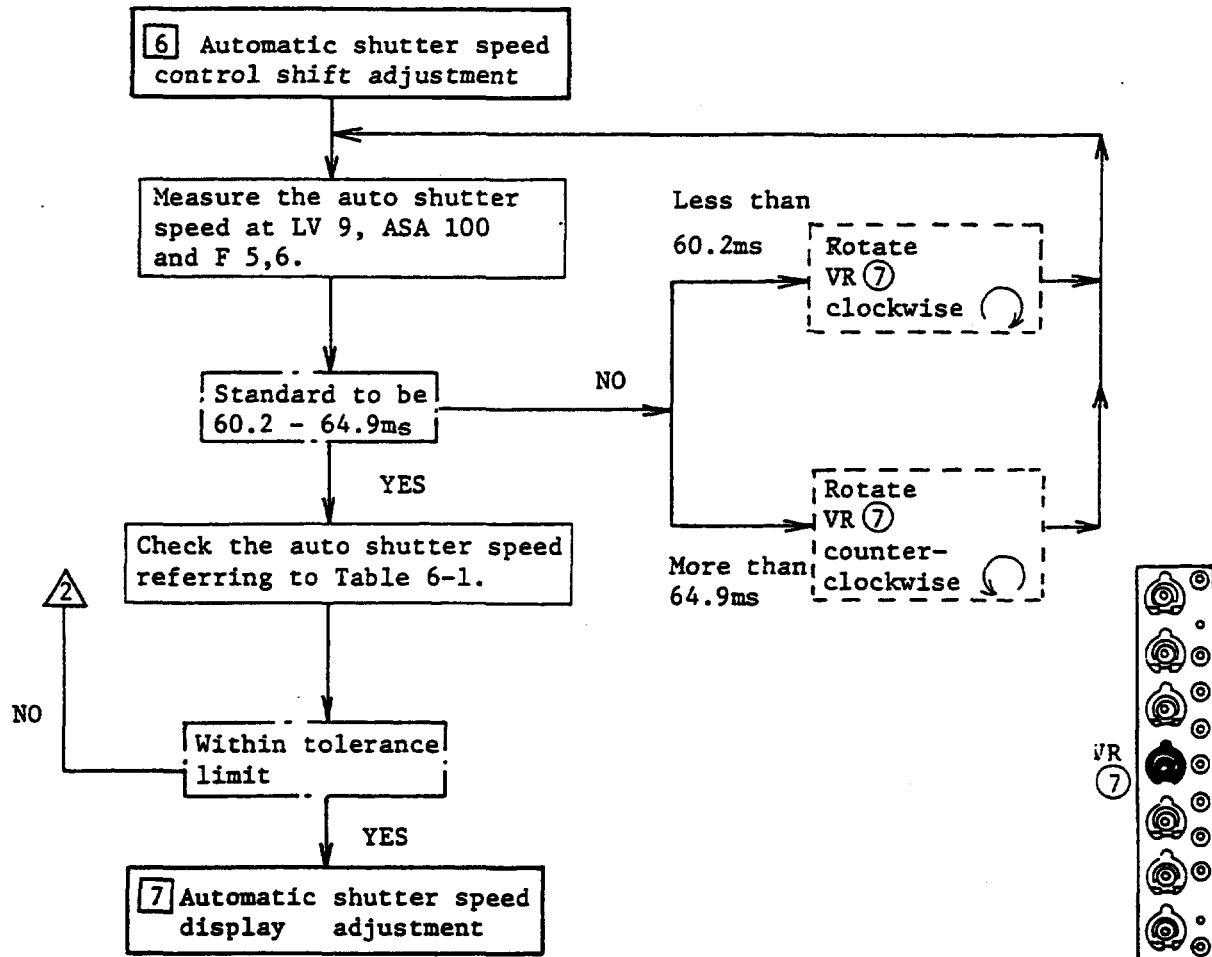

LV	ASA	F	Shutter speed	Tolerance limit(ms)
9	1600	4	1/500	1.38-2.76
9	100	5.6	1/15	44.19-88.36
9	25	8	1/2	354-707
14	100	5.6	1/500	1.38-2.76
14	400	2	1/2000	0.31-0.76
4	100	2.8	1/2	354-707
4	100	4	1/8s	707 - 1414

Table 6-1 Auto Shutter Speed Accuracy

Note(1)When measuring 1/2000 sec., set the memory lock and use J19033.
 (2)When determining "t3" and "t4", measure 5-10 times, then take the average respectively.

3-27-3-7 LCD Auto γ Adjustment

LCD means the grades of shutter speed display change in strict accordance with the change of light-intensity, ASA and F-stop (when one of these three factors is changed) e.g. when F-stop is changed from 2 to 11 (AV-5-step change), shutter speed display should change from "125" to "4" (TV-5-step change).

7 LCD Auto adjustment

Setting: Auto
ASA100

3 At LV14, rotating the aperture ring slowly from the max. aperture, measure the point where display "1000" just changes to "500" and designate it as "f1".

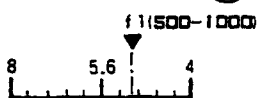

At LV9, rotating the aperture ring slowly from the max. aperture, measure the point where display "30" just changes to "15" and designate it as "f2".

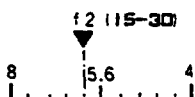

Balance between f1 and f2.

Within tolerance limit
 $f2 - f1 \leq \frac{1}{5}$ stop

f2 > f1

Rotate VR 4 clockwise

(See fig. 7-3)

f1 > f2

Rotate VR 4 counter-clockwise

(See fig. 7-2)

YES (See fig. 7-1)

8 LCD Auto level adjustment



△ fig. 7-1

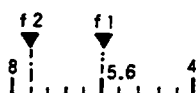

△ fig. 7-2

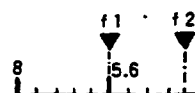

△ fig. 7-3

3-27-3-8 LCD Auto Level Adjustment

8 LCD Auto level adjustment

Check auto shutter speed display at LV14, ASA100 and F5.6

Adjust by rotating VR 5

Display "500"

YES

Rotating the aperture ring from F5.6 to F8, measure the point where display changes from "500" to "250" and designate it as "f3"

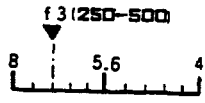

Rotating the aperture ring from F5.6 to F4, measure the point where display changes from "500" to "1000" and designate it as "f4"

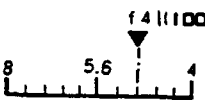

Compare the balance between "f3" and F5.6 (=Value A) with the balance between "f4" and F5.6 (=Value B)

Unequal

A < B (fig. 8-2)
Rotate VR 5 counter clockwise

A > B (fig. 8-3)
Rotate VR 5 clockwise

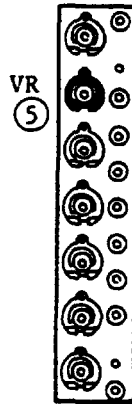

2 (fig. 8-1) Equal A=B

Check L/C display changes referring to the Table 8-4.

Non-conforming

Conforming

9 LCD Manual adjustment

LV F NO	4	9	14
2	4	125	+2000
2.8	2	60	2000
4	1	30	1000
5.6	2 ⁻	15	500
8	4 ⁻	8	250
11	8 ⁻	4	125
16	8 ⁻	2	60

Table 8-4 LCD Auto Accuracy (ASA100)

Note: Middle value of dead zone to be within $\pm 1/2EV$ as compared with standard display value.

Range of dead zone: 2/3 - 4/3EV

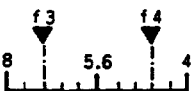

2 fig. 8-1

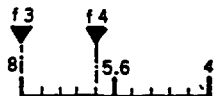

2 fig. 8-2

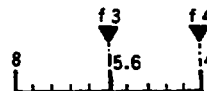

2 fig. 8-3

3-27-3-9 LCD Manual γ Adjustment

9 LCD Manual adjustment

3

Setting: Shutter-speed dial... Manual
ASA... 100

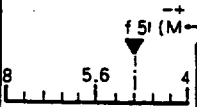

At LV14 and 1/1000, rotating the aperture ring from the max., measure the point where display ΔM^+ changes to \bar{M}^+ and designate it as "f5"

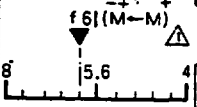

At LV9 and 1/30, rotating the aperture ring from the max., measure the point where display ΔM^+ changes to \bar{M}^+ and designate it as "f6"

Blance between f5 and f6

Within tolerance limit
 $|f6 - f5| \leq \frac{1}{5}$ stop

YES (See fig.9-1)

10 LCD Manual shift adjustment

NO
f5 < f6
(See fig.9-3)

Rotate VR 9 clockwise

f5 > f6
(See fig.9-2)

Rotate VR 9 counter-clockwise

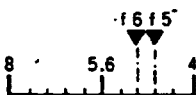
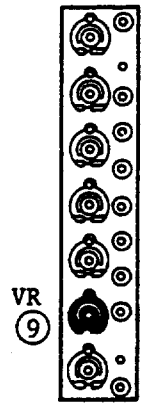

Δ fig. 9-1

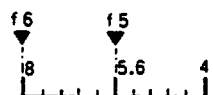

Δ fig. 9-2

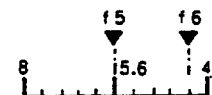

Δ fig. 9-3

3-27-3-10 LCD Manual Shift Adjustment

10 LCD Manual shift adjustment

Setting LV14, ASA100, M1/500 and F5.6, check the display

Display "M⁺"

NO

Adjust by rotating VR ⑥

YES

Rotating the aperture ring from F5.6 to F8, measure the point where display changes from "M⁺" to "M" and designate it as "f7".

Rotating the aperture ring from F5.6 to F4, measure the point where display changes from "M⁺" to "M" and designate it as "f8".

Compare the balance between "f7" and F5.6 (=Value C) with the balance between "f8" and F5.6 (=Value D)

C < D
(fig. 10-2)
Unequal

Rotate VR ⑥ clockwise

C > D
(fig. 10-3)

Rotate VR ⑥ counter-clockwise

Equal (C=D)
(fig. 10-1)

Check L/C display change referring to the Table 10-4

Non-conforming

Conforming

11 Speedlight level adjustment

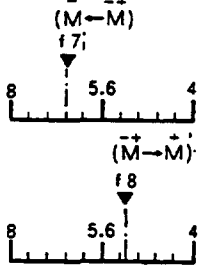
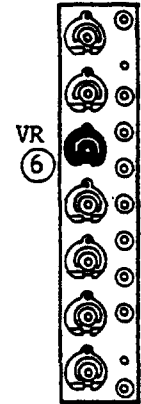

LCD Manual Accuracy (ASA100)

LV	T	F	Correct display
14	1/2000	2.8	
	1/60	16	
9	1/125	2	M ⁺
	1/2	16	
4	2s	5.6	

Note: Middle display accuracy of dead zone to be within $\pm 1/5EV$ at every measuring point

Range of dead zone:
 $0.5 \pm 0.2EV$

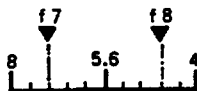

△ fig. 10-1

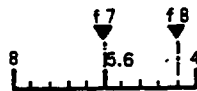

△ fig. 10-2



△ fig. 10-3

3-27-3-11 Speedlight Level Adjustment

Speedlight level is to conform the amount of camera's signal to be transmitted into the exclusively designed speedlight to the standard value. Camera's signal: the subject light-intensity reflected by the film plane is electrically converted into the signal in the camera body and transmitted to the speedlight mounted onto the camera immediately after the shutter is released for auto-flash picture-taking.

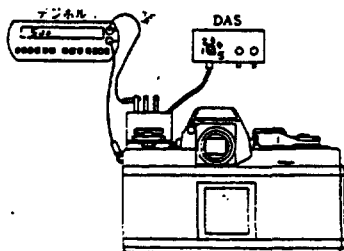

- 1) Connect DAS conductivity check tool J18078, Dummy Strobe J18077 and Digital multimeter J9003 as shown in fig. 11-1 and mount J18077 on the shoe mount.
- 2) Place Standard reflector J15196 to the aperture of the camera.

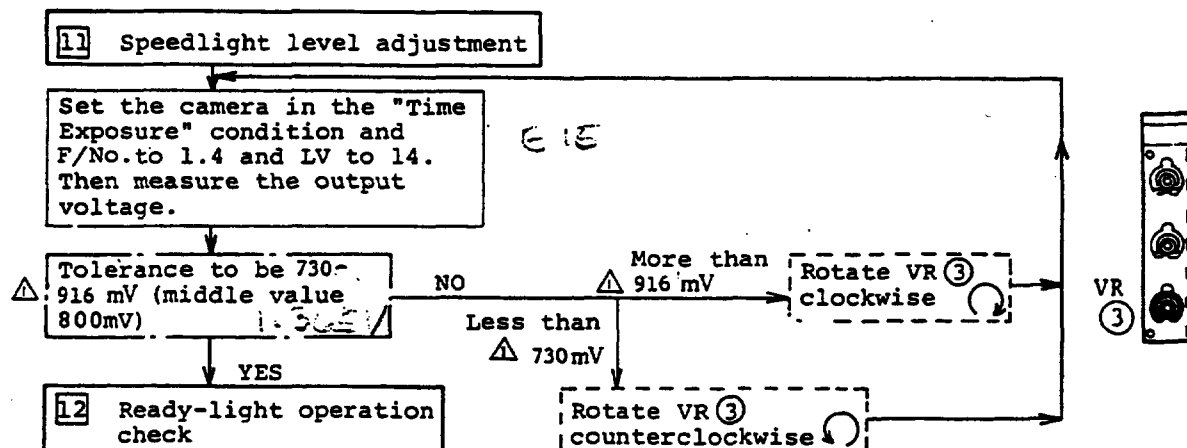

3-27-3-12 Ready-light Operation Check

- 1) Connect READY terminal and GROUND terminal of J18078 to the READY terminal of J18077 and camera body respectively.
- 2) Check the operation at LV9 referring to the table below.

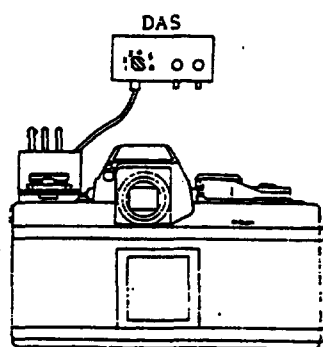

SHUTTER SPEED J18078	SHUTTER SPEED			READY-LIGHT
	sec.	AUTO	1/2000 - 1/125	
OFF	Δ 2000 ~ 8	2000 ~ 125	60 ~ 8	OFF
READY 1	80 (1/70)	80 (1/70)	60 ~ 8 (AS SET)	ON
READY 2	80 (1/70)	80 (1/70)	60 ~ 8 (AS SET)	OFF

3.28 Top Cover, rewind side

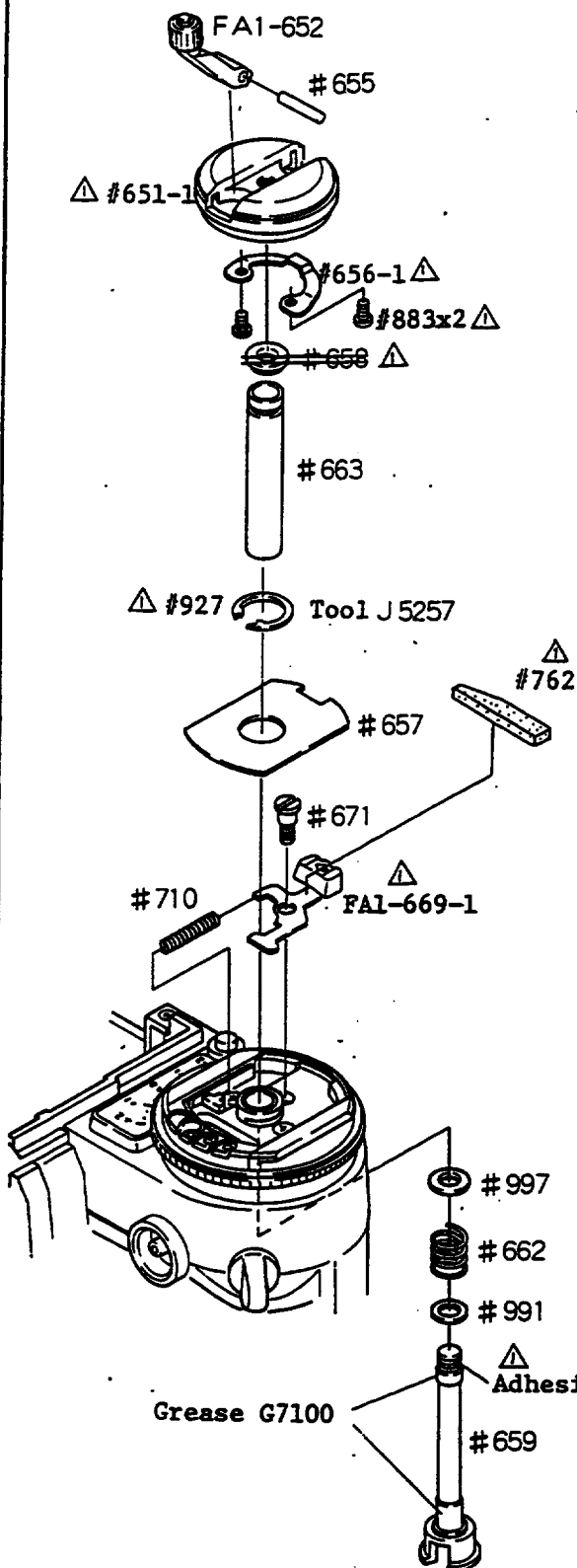

Camera body

Spring #710
Tab FA1-669-1 Δ

Screw #671

After installation, check #710
and FA1-669 for proper operation.Cover #657
Snap ring #927 Δ

Tube #663

Washer #997
Friction spring #662
Washer #991
Rewind shaft #659~~Washer #658 Δ~~
Spring #656-1 Δ \oplus 883x2 Δ Rewind knob #651-1 Δ
Rewind crank FA1-652
Rod #655

Check Points

- 1) Rewind knob should securely click into place.
- 2) Rewind knob should rotate smoothly.
- 3) Camera back should securely open when Rewind knob is lifted.

3-29 Top Cover, Wind side

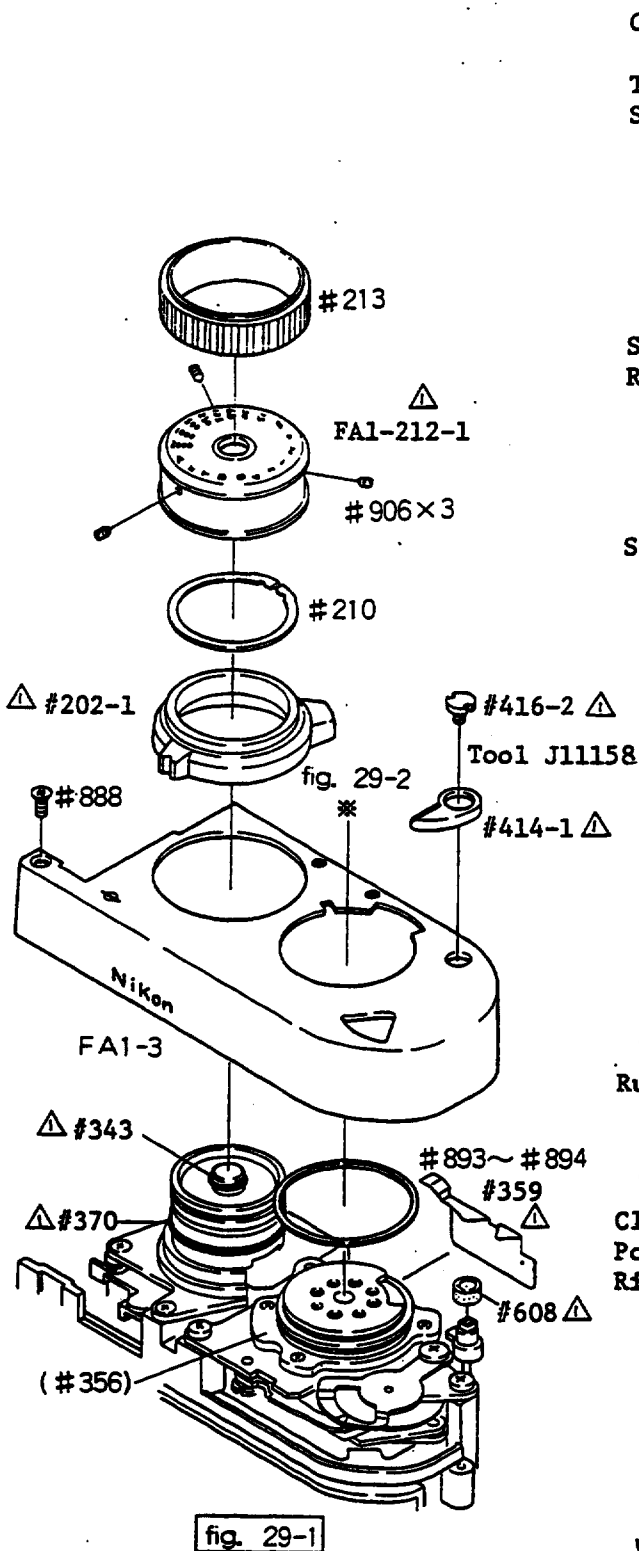

Camera body

Top cover, wind side FA1-3,
Screw ⊕ #888

If clearance between FA1-3 and
#356 can be detected, rectify
by adding Washers:

#893; $t = 0.05$ #894; $t = 0.1$

Self-timer lever #202-1△

Retaining ring #210

Check that Lever #202 rotates
smoothly and that it clicks
into place.

Shutter-speed selector FA2-212-1 △

Check Points

- 1) The dial should securely click into every setting when it is rotated slowly.
- 2) When the viewfinder is mounted, more than half breadth of the index on the viewfinder should align with the figures on the dial at every click-stop setting.
- 3) At both "A" and "X" settings, the dial should lock into place. When the auto-lock button is depressed, locking should be released.

Rubber ring #213

Before installation, apply plibond
to a few portions inside the ring.

Click spring #350

Power lock lever #341

Ring #353

Tool: J11156

Check that Lever #341 rotates
smoothly and that it clicks into
place.

Film-advance lever FA1-354
 Washer #358 or #986 Δ
 Stopper #348, Screw \oplus #881 x 4

When installing, align the center of #348 with that of Take-up shaft FA1-342 for smooth release button's movement.

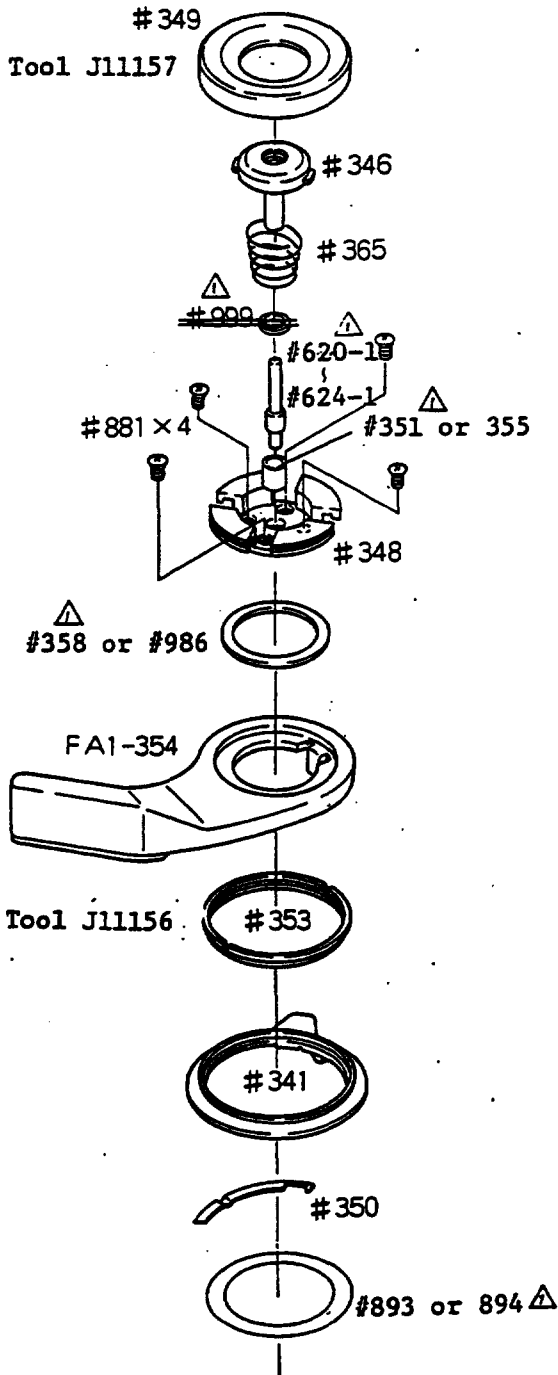

Release button shaft #346, Spring #365
~~Washer #999 (for adjusting play of stroke p. A17)~~ Δ
 Cover ring #349

Tool: Rubber pad J11157

Check Points

- 1) When Power lock lever is set to ON-position (red dot appears) and the release button is depressed slightly, liquid crystal display should appear and when the release button is depressed further down, the shutter should be released.
- 2) When Power lock lever is set back to OFF-position, and the release button is depressed slightly, L/C display should appear.
- 3) After film-advance operation, when the film-advance lever is being returned slowly with finger-pressure applied, the lever should move back and be flush with the camera body securely.
- 4) Release-button should be depressed smoothly.

Multi-exposure lever #414-1 Δ
 Screw #416-2 (fig. 29-1) Δ

Tool: J11158

- 1) Lever #414 should be set smoothly. Neither the spool nor the sprocket should rotate during film-advance operation.
- 2) At multi-exposure operation, Cam #591 should not be disengaged.
- 3) After the lever is set to multi-exposure position, when the lever is pushed back with the finger, multi-exposure operation should be cancelled.

新 FPC, 新 US ボデー
New FPC, New US body

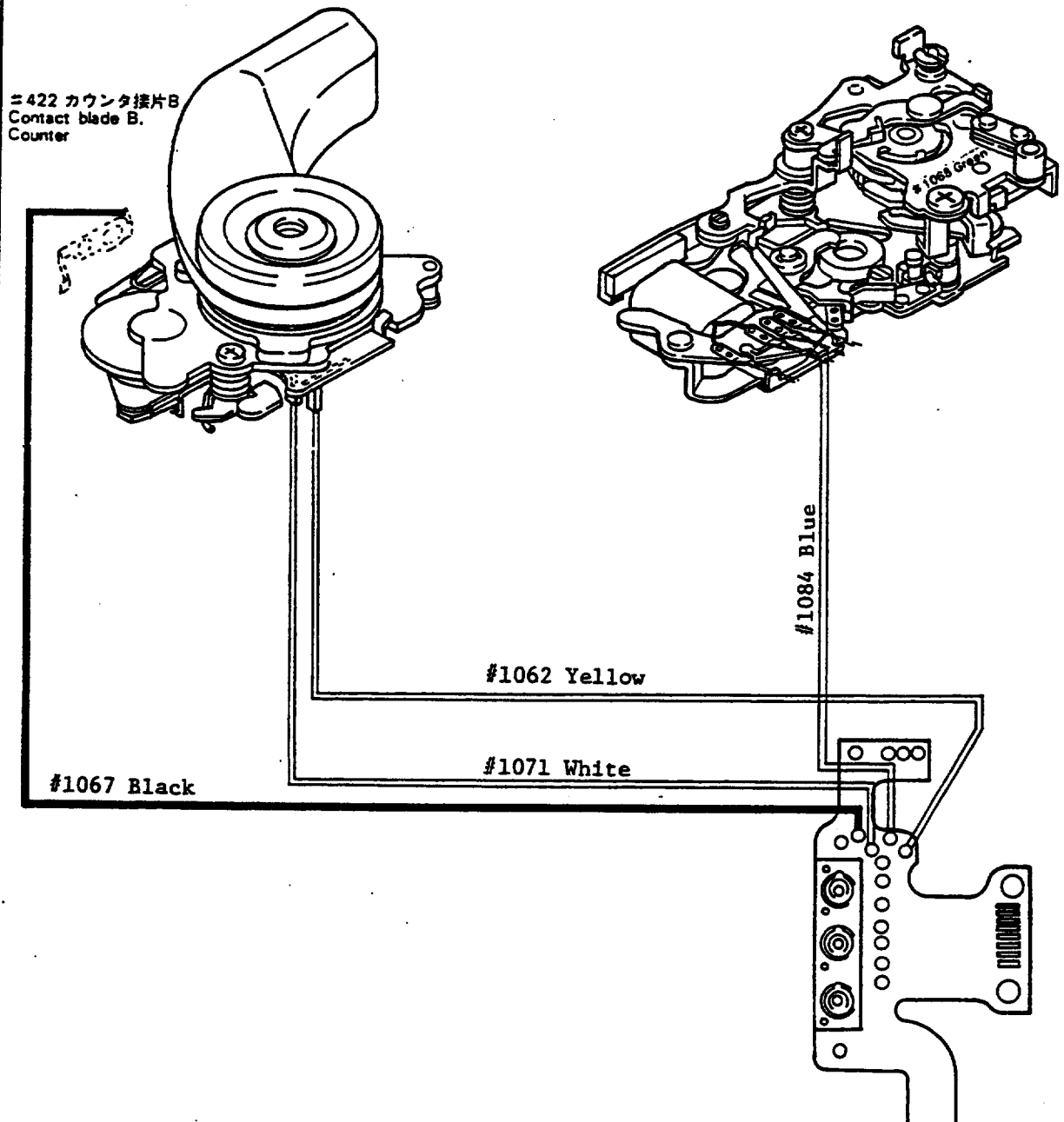

Section 3

Content

3-31 Unit, mirror-box (rewind-side)	S1
3-32 Mirror Holder and Unit, mirror-box actuating	S2
3-33 Front Plate Unit	S4
3-34 Adjustments of Mirror 45° angle, Infinity focus and Parallax	S5
3-35 Front Plate Unit Check/Adjustment	S6
3-36 Display Block	S8
3-37 Shutter-speed Selector	S10
3-38 Shutter-speed Selector Circuit,	S12
3-39 Shutter Curtain Replacement	S13

3-31 Unit, mirror-box (rewind-side)

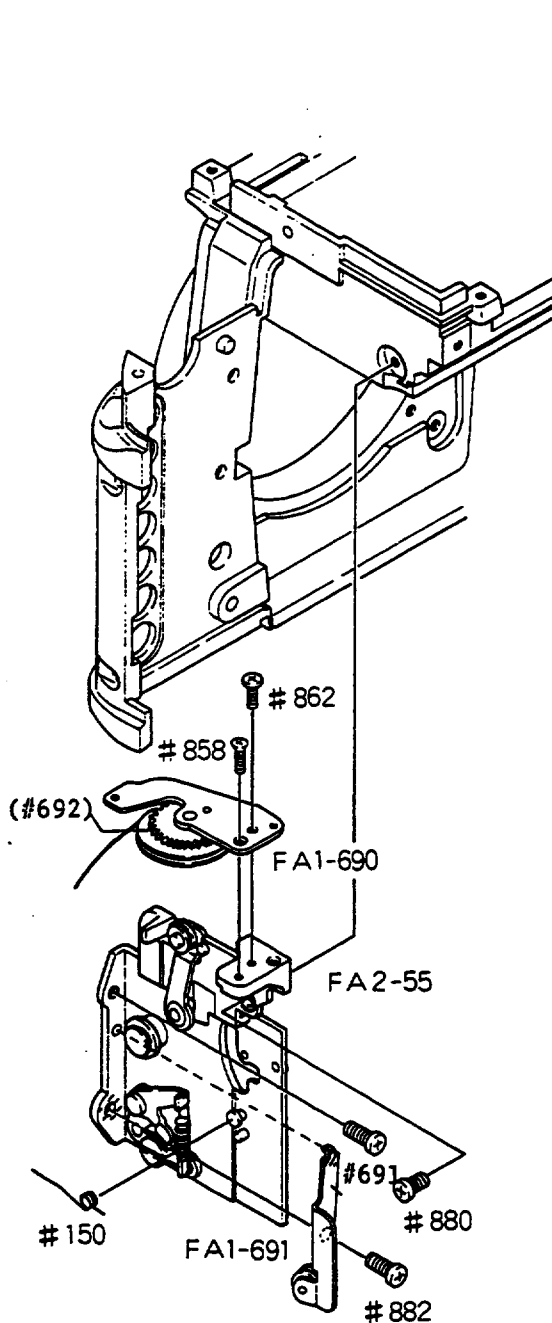

fig. 1-1

Front plate, rewind-side

Front plate unit

Unit base FA2-55
Retainer FA1-691

Put the protrusion of (#691)
into the hole of FA1-55.

Screw ⊕ #882 x 2
Screw ⊕ #880

When tightening screws, place
FA1-55 in the direction of arrow.
(See fig. 1-1.)

Unit base, aperture coupling
thread FA1-690

Take up Aperture coupling
thread (#732) around Pulley A
(#689) and Pulley B (#694).

The engagement of gears
of Winding roller #692 is
shown on P. S5.

Screw ⊕ #858
Screw ⊕ #862

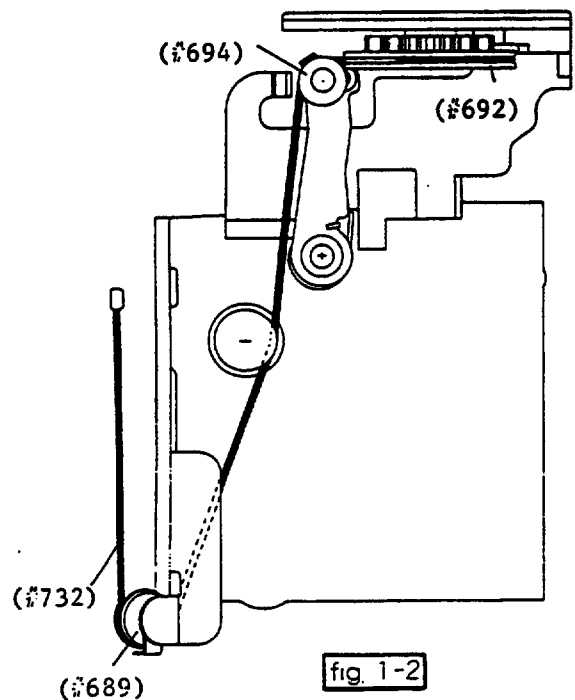
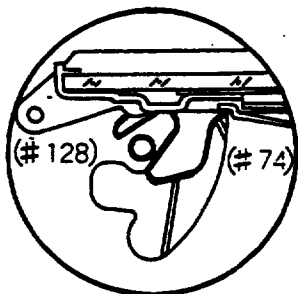
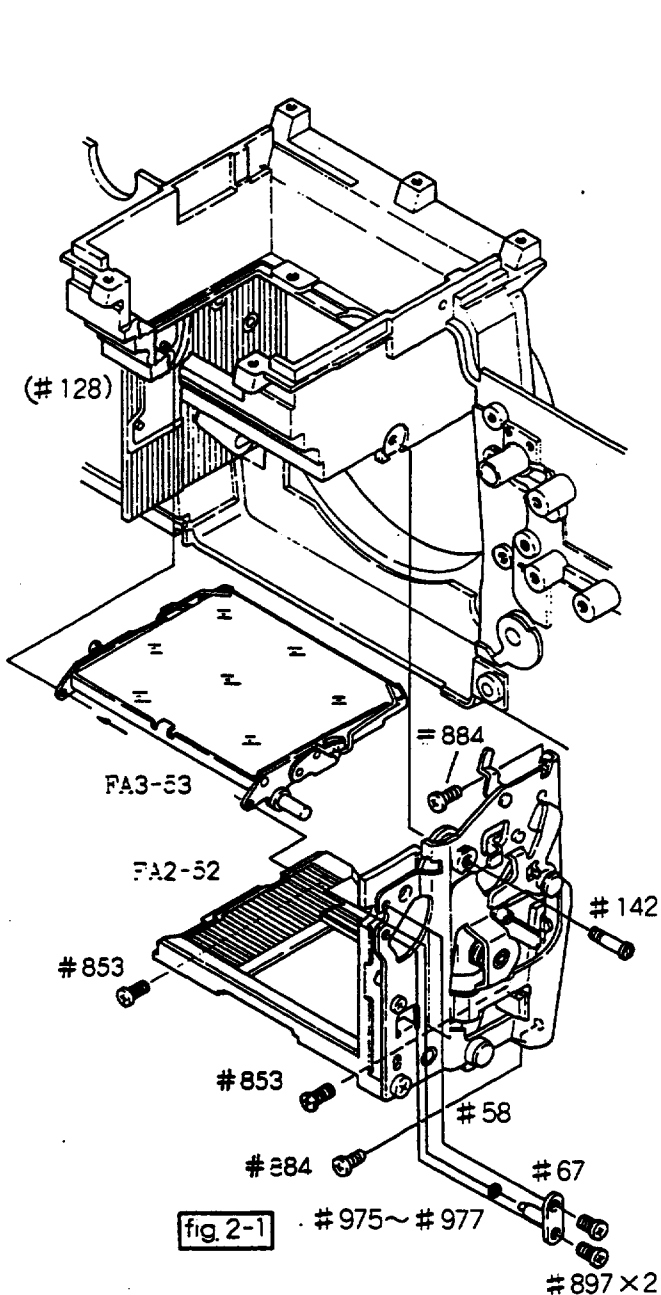

fig. 1-2

3-32 Mirror Holder and Unit, mirror-box actuating



Front plate unit

Mirror holder FA3-53

Attach FA3-53 to FA3-52, and link the fork of Stay (#74) to Pin (#128).

Unit FA2-52

When installing FA2-52, use care to the followings:

- 1) Position Pin #117 above Main lever #59. (fig. 2-4)
- 2) Engage Pin #167 with Actuating lever #63. (fig. 2-4)
- 3) Bring Mirror-up lever #62 against Acceptor #61.

Screw ⊕ #884 x 2

Screw ⊕ #881 x 2

Screw ⊖ #142

Screw #142 positions FA3-52 for the proper installation.

Washer #975, #976, #977
(respective thickness: 0.1, 0.2, 0.3mm)

Mirror bearing shaft #67

Put the shaft of #67 into the hole of Mirror holding arm (#70).

Screw ⊕ #897 x 2

- 1) Check the mirror for horizontal play: 0.05 - 0.15mm
For adjustments, replace Washers #975 - 977.
- 2) Hold the mirror upward with the finger, then see if the mirror returns to the viewing position when releasing the finger.

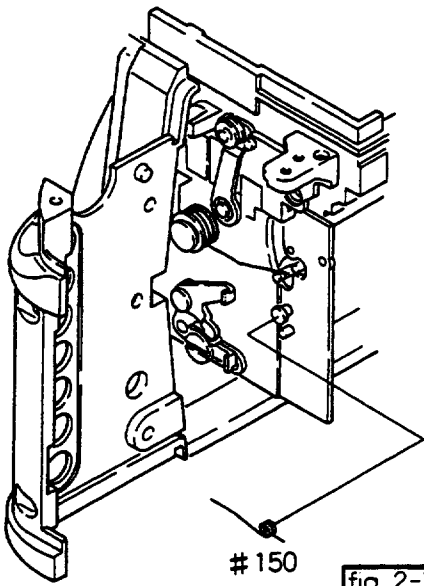

fig 2-3

↓
Spring #150

Fig. 2-5 shows how to hook Springs #150 and #144.

Check again the mirror for its smooth movement.

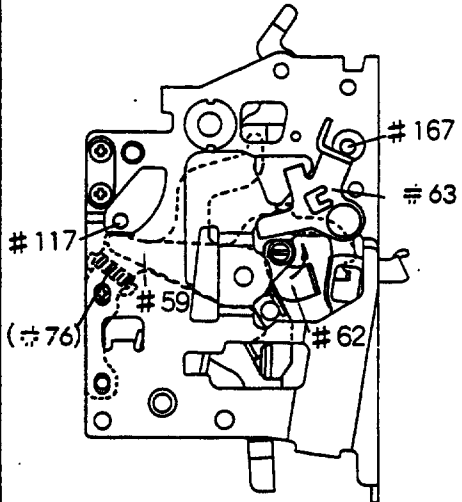

fig 2-4

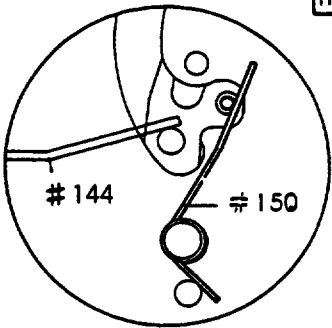

fig 2-5

3-33 Front Plate Unit

Front plate unit

Lever #738

Axle #737

Axle #739

Spring #746

Snap ring #922

Fig. 3-1 shows how to hook Spring #746.

After installing, check #738 for smooth movement.

Coupling lever #169
Axle #168

Use Tool J11162

Coil #199, Screw ⊕ #884 x 3

When installing #199, use care to the follow-ings:

Provide 0.5mm clearance between Lever #65 and Shaft #99.

Hold Vertical lever FA1-58 in the changed position.

When installing #199, the depth of engagement between #65 and Mirror release claw should be 0.7 - 0.8mm.
(See fig. 3-3.)

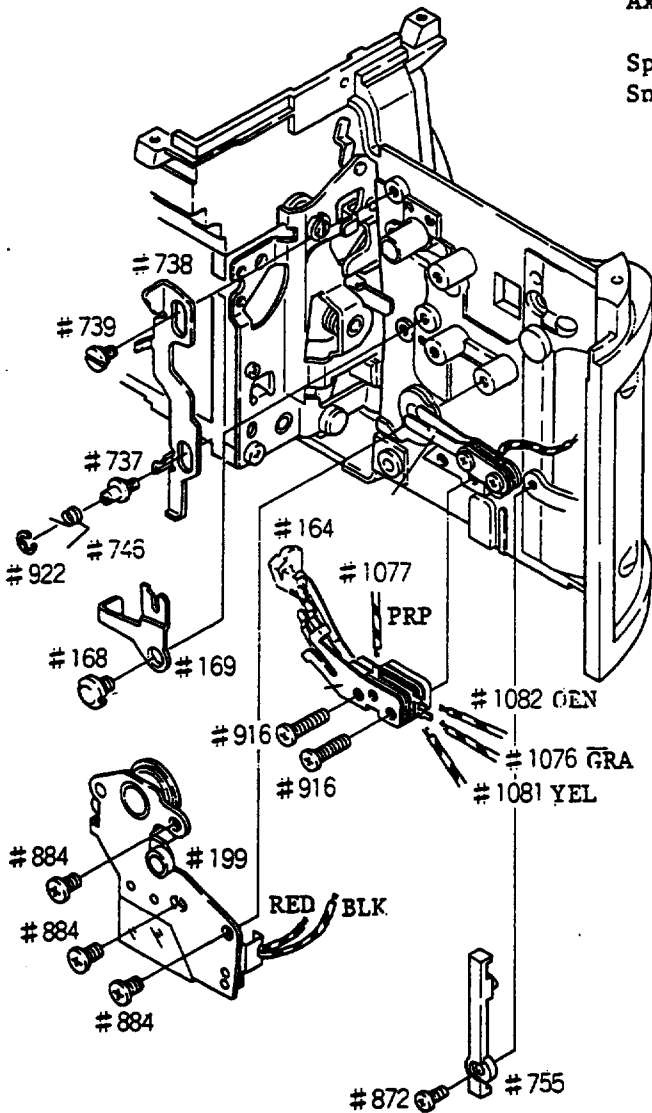

fig. 3-1

Unit base FA2-751

When installing FA1-751, put Contact blade A and Safety contact A FA1-755 underneath Insulator (#164).

Pass Lead wires #1076 and #1077 through the hole of Unit base (#751).

Screw ⊕ #870 x 2

Lead wire #1076

Lead wire #1077

Solder #1076 and #1077 in place

Guide #775

Screw ⊕ #872

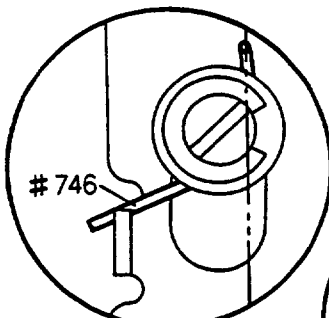

fig. 3-2

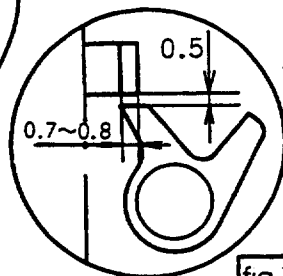

fig. 3-3

3-34 Adjustments of Mirror 45° Angle, Infinity Focus and Parallax

When either FA3-52 or FA1-55 is removed in repairs, the Mirror-45 and the parallax should be always adjusted.

The Repair Manual Nikon FE p.31 shows the adjusting procedures in more detail.

3-34-1. Mirror 45° Angle

- Standard: ① Misaligning image in the vertical direction: +10' - -15'
- ② Misaligning image in the horizontal direction: $\pm 20'$
- ③ The width of out-of-focus image: less than 5'

Adjustment:

- ① can be adjusted by rotating Pin (#77). (fig. 4-1)
- ② can be adjusted by re-locating #67. (fig. 4-2)
- ③ can be adjusted by replacing GII or Mirror holder FA3-53.

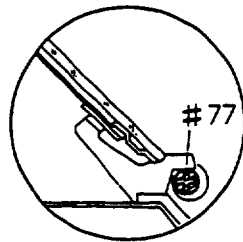

fig. 4-1

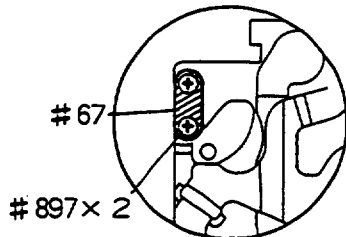

fig. 4-2

NOTE: THE INFINITY FOCUS AND THE PARALLAX SHOULD BE ADJUSTED AFTER COMPLETION OF CAMERA BODY REASSEMBLING.

3-34-2 Infinity Focus

Standard: Misaligning image -15" - +30"

Adjustment can be made by replacing Washers #978 - #983 or Viewfield frames #113 - #115. (See fig. 4-3.)

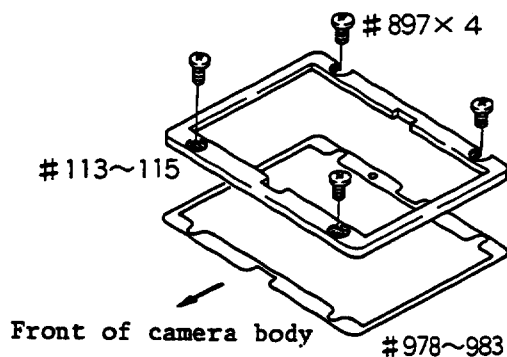

fig. 4-3

3-34-3 Parallax Error

Standard to be \pm in the vertical and horizontal direction.

Adjustment is possible by loosening Screw \oplus #897 x 4 and by re-locating viewfield frame. (See fig. 4-3.)

3-35 Front Plate Unit Check/Adjustment

3-35-1 Main lever FA1-59

When FA1-59 is set to the charged-condition and Lever #65 is released by Coil #199, FA1-59 and Mirror holder #53 should move smoothly.

When FA1-59 is returned to the rest position slowly, FA1-59 should be coupled to #65.

When a lens is mounted or the mirror is locked up, FA1-59 works properly as above.

3-35-2 Contact blades #757 and #758, and Safety contacts #755 and #756 (Shutter release switch)

Check both of them for the clearance between the switching blades, after holding FA1-59 to the changed condition.

Standard clearance between #757 and #758: 0.5mm
#755 and #756: 0.4mm
#764 and #765: 0.5mm

Adjustments can be made by bending Retainer #759 or Contact blade B (#765).

3-35-3 Contact blades #764 and #765 (Memory Lock Switch)

Check that Memory lock button #744 surely closes the memory lock switch when depressed and that it opens the switch when restored.

3-35-4 Height of Aperture Lever

Check the height of aperture lever when Main lever FA1-59 is set to the charged-position.

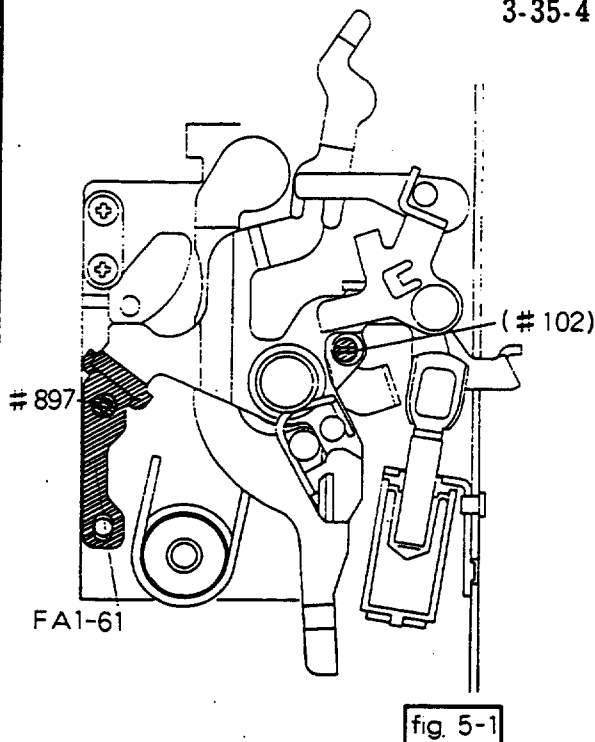

Standard

- ① Charged-position: 3.1 ± 0.1 mm
- ② Released-position: Less than 3.65mm
- ③ Balance between ① and ②:
More than 0.2mm

Adjustment

- ① Rotate Pin (#102)
- ② Loosen Screw ⊕ #897 and re-locate Acceptor FA1-61 (See fig. 5-1).

3-36 Display Block, exposure information

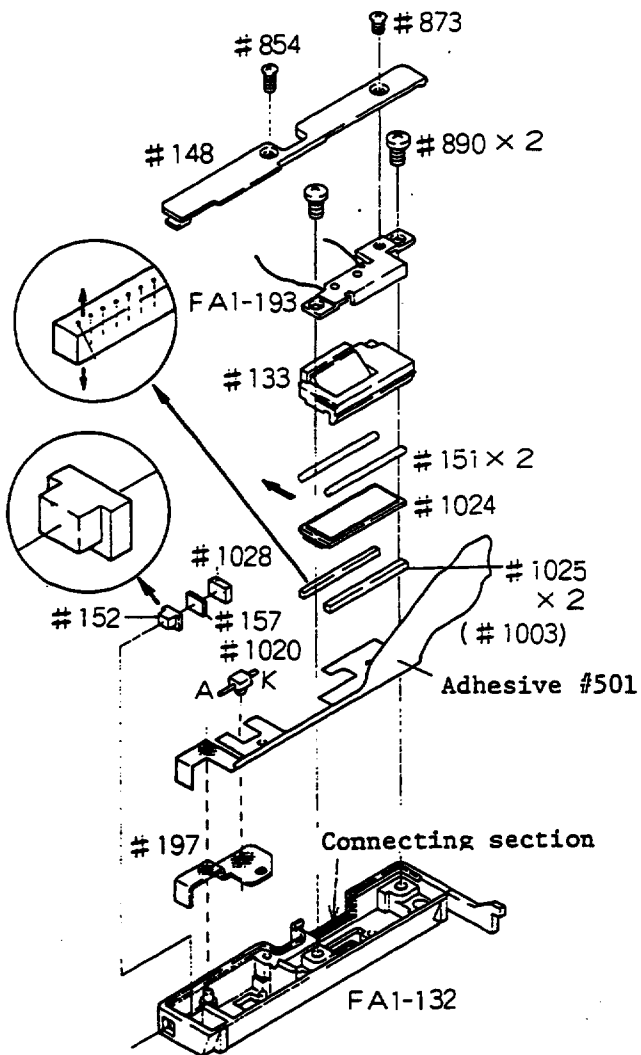

fig. 6-1

Display block FAI-132

↓
Base plate #197

Install #197 aligning its hole with the boss of FAI-132.

↓
FPC #1003

Apply Pliobond on the back of #1003 and cement #1003 in place, aligning its hole with the boss of FAI-132.

See if the connecting section of #1003 is flat and it connects with #1024 efficiently.

↓
Erastic connector #1025

LCD #1024

When cementing, bring the connecting face of #1025 against #1024 (See fig. 6-2).

Place #1024 as far as it will go in the direction of arrow.

Note that #1025 should be carefully cemented in place for preventing malfunctional display.

↓
Rubber #151 x 2

Window #133

Use Pliobond to cement #151 in the groove of #133.

↓
Retainer FAI-193

Screw ⊕ #890 x 2

Do not over-tighten #890.

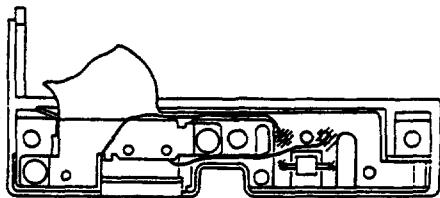
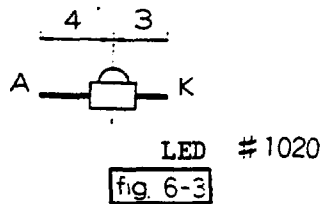

fig. 6-4

↓
Illuminator button #152

↓
Fig. 6-1 shows how to install #152.

↓
Contact plate #157

Piezoelectric semiconductor #1028

↓
Insert #157 into #152, and insert #1028 into #1003.

↓
LED #1020

↓
Fig. 6-3 shows the polarity of #1020.

↓
Soldering

↓
Solder #1020 and the lead wires.

↓
Put the lead wires into the groove of FA1-132. (fig. 6-4)

↓
Cover #148

Screw ⊕ #854

Screw ⊕ #874

Do not overtighten #854 and #874.

Check #1024, #1020 and #152 for proper operation.

When the display is malfunctional, check the defective segment and re-locate or replace #1025, #1024 and #1003.

3-37 Shutter-speed Selector

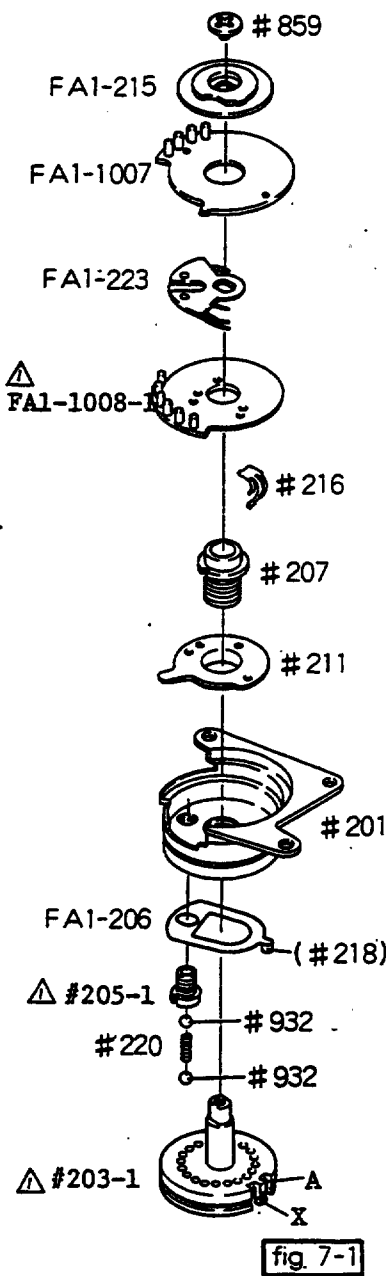

fig 7-1

- Unit base #201
- ↓
- Disk #211
- Retaining ring #207
- ↓
- Spring FAI-206
- Tube #205-1 Δ
- ↓
- See if FAI-206 moves smoothly along the groove of #201.
- ↓
- Steel ball #932
- ↓
- Spring #220
- ↓
- Steel ball #932
- ↓
- Click stop disk #203-1 Δ
- ↓
- Drop Lock pin #218 into the groove A.X of #203.
- ↓
- Brush contact A #216
- ↓
- Insert the protrusion of #216 into the hole of #211.
- ↓
- Gray cord board FAI-1008-1 Δ
- ↓
- Supporter FAI-223
- ↓
- Fig. 7-2 shows how to install FAI-223.
- ↓
- Manual resistor FAI-1007
- ↓
- Brush retainer FAI-215
- ↓
- Fig. 7-3 shows how to install FAI-215 in place.
- ↓
- Screw \oplus #859

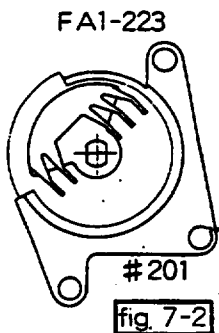

fig 7-2

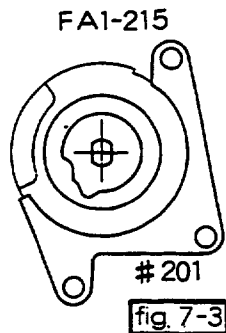

fig 7-3

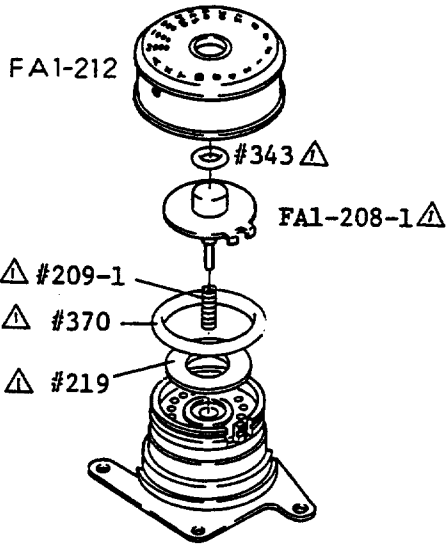

fig. 7-4

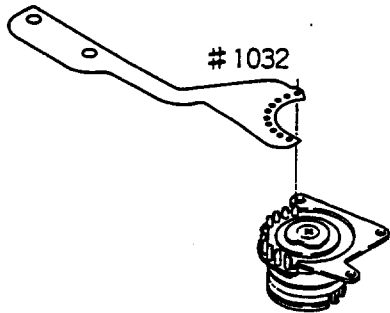

fig. 7-5

- △Washer #219
- △O-ring #370
- △Spring #209-1
- ↓ Disk, auto-lock release FAI-208-1 △
- ↓ O-ring #343 △
- ↓ Shutter-speed selector FAI-212

Check FAI-212 for its click-stop and locking at A or X settings.

FPC 4 #1032

After aligning the through-holes of pins A·B with the holes of FPC 4, solder them as shown in fig. 7-5.

Do not damage the FPC by heat.

3-38 Shutter-speed Selector Circuit Check

3-38-1 Gray Code (Cyclic Binary Code) Check

Use a digital multi-meter to check gray code signal at each shutter speed setting. Connect the test prod positive to the terminals V.W.X.Y.Z, and the test prod negative to the ground.

See P. E16 about the gray code.

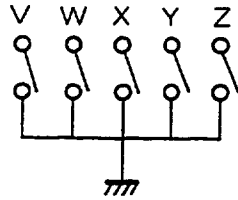

1 : Current flow.

0 : Current fails to flow.

	V	W	X	Y	Z
2000	0	1	0	0	0
1000	0	1	0	0	1
500	0	1	0	1	1
250	0	1	0	1	0
125	0	1	1	1	0
60	0	1	1	1	1
30	0	1	1	0	1
15	0	1	1	0	0
8	0	0	1	0	0
4	0	0	1	0	1
2	0	0	1	1	1
1s	0	0	1	1	0
2s	0	0	0	1	0
4s	0	0	0	1	1
8s	0	0	0	0	1
B, T	0	0	0	0	0
X	1	0	0	0	0
AUTO	1	1	0	0	0

3-38-2 Manual Setting and Auto-manual Changeover

Connect the test prod positive to the terminals of 1/2000, Auto, 8 sec, and the test negative to the COM.

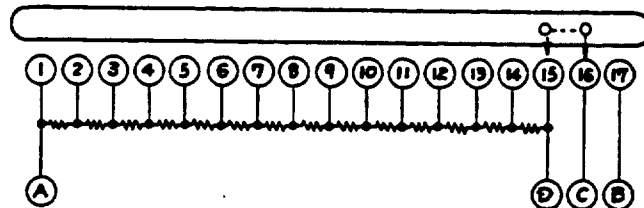
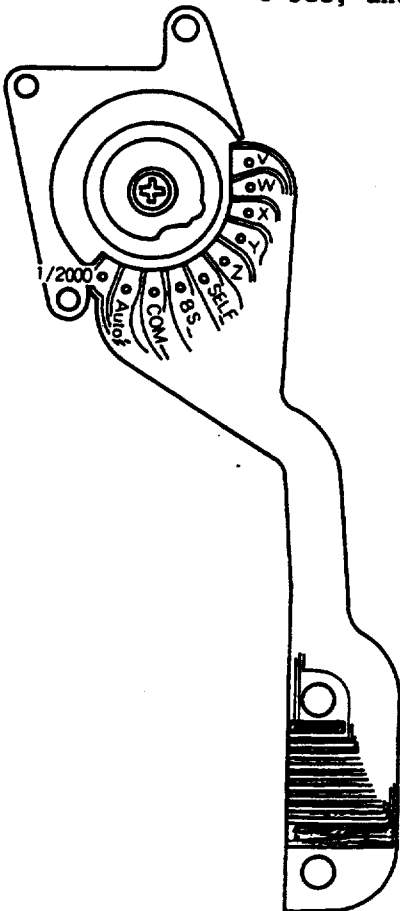

mode Terminal	Auto	Manual	B.T.X
1/2000 - COM A - C	OFF	18k /EV 1.8 - 27k	OFF
Auto-COM B - C	ON	OFF	OFF
8 sec. COM D-C	OFF	variable	OFF

3-39 Shutter Curtains Replacement

3-39-1 Disassembly Procedures

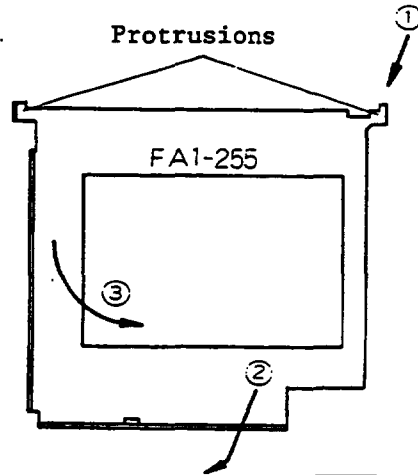

fig. 9-1

Camera body

↓
Front plate unit↓
FPC↓
Battery chamber FA2-20
Screw + #882 x2↓
Light-shield FA1-255
Screw + #855 x2↓
Lift off FA1-255 from Unit
base #281 in the order 1-2-3.
When re-installing, reverse
this order.↓
Shutter curtains

Closing curtain bar

3-39-2 Replacement Procedures

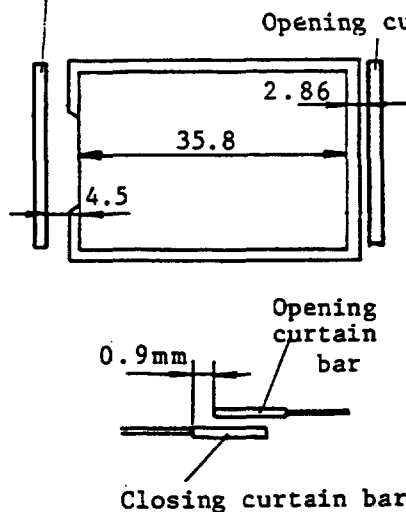

The Repair Manual Nikon F2 (Body) Supplement illustrates the procedure in detail.

	Reference points	Standard
Opening curtain	From the edge of aperture to the opening curtain bar	2.86mm
Closing curtain	From the edge of aperture to the closing curtain bar	4.5mm
Overlap	See fig. 9-3.	0.9mm

3-39-3 Note the Following When Replacing the Curtains

- 1) Use care not to damage the FPC
- 2) Setting the camera body in the shutter-released condition, rotate Winding roller FA1-440 counterclockwise and check that Brush lever #502 firmly comes in contact with Pin #501.
- 3) When adjusting the tension of the curtain, rotate Tension gears clockwise as below
 - Opening curtain - Tension gear #467 - Turn 2-1/2 - 3-1/2 turns
 - Closing curtain - Tension gear #462 - Turn 1/2 - 3/4 turns
- 4) Adjust the time of shutter curtains travel at 1/2000 sec. setting.

Standard to be 10.0±0.5 ms

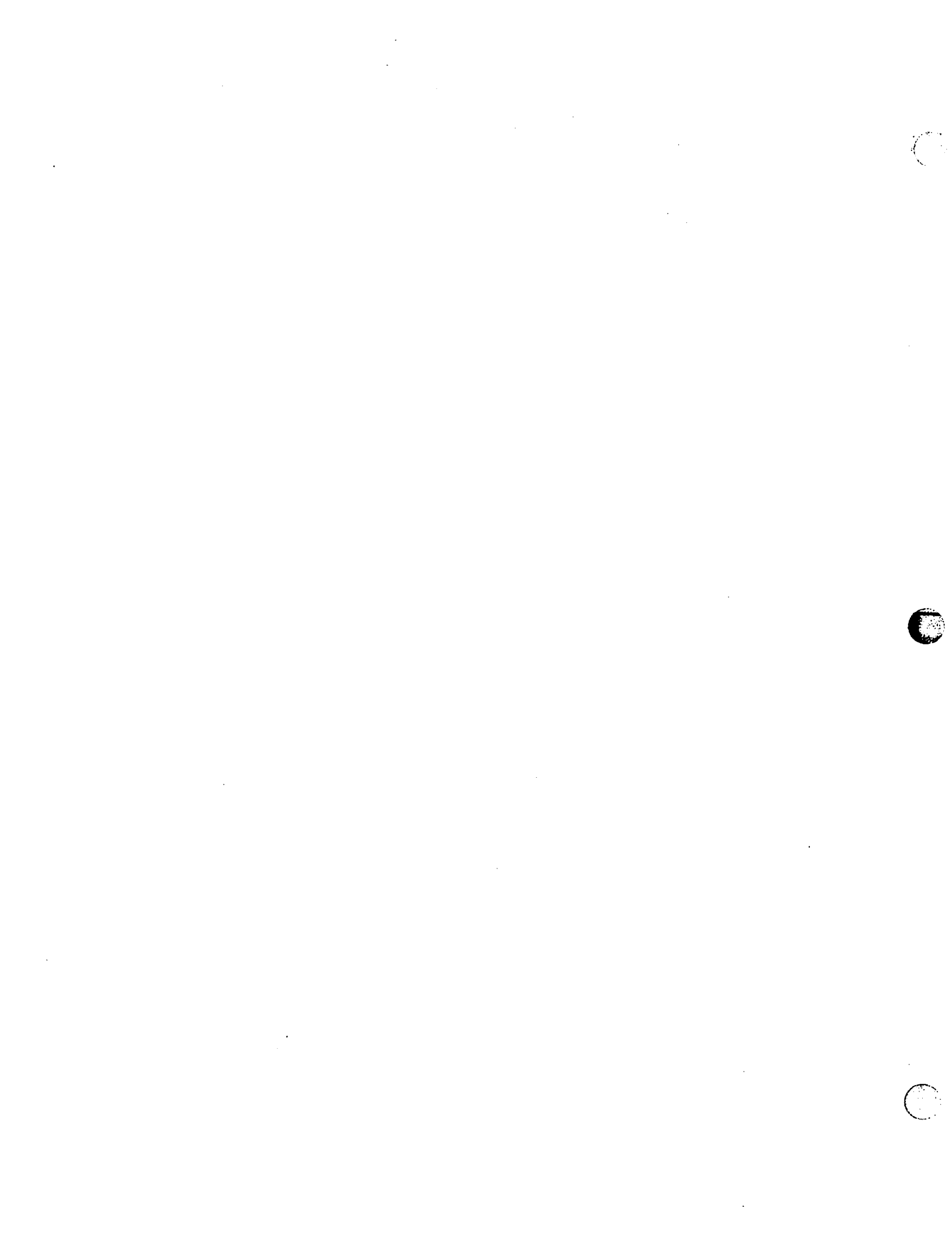

Section 4 Electric circuit

Contents

4-1 Precautions	E1
4-2 Checking Lands and External Figures of Main Parts	
4-2-1 FPC 1 #1001 (Checking Lands)	E2
4-2-2 #1001 Checking Lands	E3
4-2-3 Ceramic, exposure information #1004 (Checking Lands)	E4
4-2-4 Ceramic, exposure information #1004 (External Figure)	E5
4-2-5 Ceramic, LCD #1005 (Checking Lands)	E6
4-2-6 Ceramic, LCD #1005 (External Figure)	E7
4-2-7 Ceramic, Quartz Oscillator #1006 (Checking Lands)	E8
4-2-8 Ceramic, Quartz Oscillator #1006 (External Figure)	E9
4-2-9 Resistor Block A #1009	E10
4-2-10 Resistor Block B #1030	E11
4-3 Outlines of Shutter Control System	
4-3-1 Power Supply	E12
4-3-2 Shutter Release	E14
4-3-3 Auto Shutter Speed Control	E16
4-3-4 Manual Shutter Speed Control	E20
4-3-5 Exposure Information Display on Auto	E22
4-3-6 Exposure Information Display on Manual	E24
4-3-7 Connection with Motor Drive	E26
4-3-8 Self-timer	E28
4-3-9 Frame-counter	E28
4-3-10 Speed-light	E28
4-3-11 Viewfinder Illuminator	E28
4-4 Trouble-Shooting Chart	
4-4-1 Shutter fails to be released	E30
4-4-2 Shutter provides only the Time operation	E32
4-4-3 Shutter delivers only the speed of 1/2000 sec.	E34
4-4-4 Shutter speed delivery is unstable on Auto	E35
4-4-5 Shutter speed delivery is unstable on Auto and Manual	E38
4-4-6 LCD will not change +2000.	E41
4-4-7 LCD will not change -8-.	E41
4-4-8 LCD will not change M [†]	E41
4-4-9 LCD will not change M.	E42
4-4-10 Troubles of LCD	E43
4-4-11 Troubles of Self-timer	E45
4-4-12 Troubles of Speed-light	E45
4-5 Causes	E46



4-1 Precautions

- 1) On troubleshooting, it is most important to know a trouble correctly. For instance, if you have unstable shutter speeds delivery on Auto-setting, you should use care also to check the Manual-settings or the LCD's operation.
- 2) Note that this troubleshooting section will not cover all the troubles, which cause in the field-use of equipment. You then need to read the Outlines of Shutter Control System enough to isolate an unknown trouble for yourself. \triangle
- 3) This troubleshooting section does not show how to make adjustments of each trouble in practice. Please refer to 3-27 Shutter and Meter Accuracy Adjustments.
- 4) Tips for the Troubleshooting Chart:

It is possible for you to measure almost every checking land before removing the front plate. \triangle

When measuring the voltage or the resistance of a checking land, connect the test prod negative onto the camera body as the ground and the prod positive onto the checking-land to be tested. \triangle

It is to be recommended to use an oscilloscope for every voltage measuring, as well as checking of wave forms.

- 5) Abbreviations and symbols in alphabetical order

BAT ----- Battery (its terminal positive)
 BC ----- Battery checker
 BP ----- Back plate of LCD
 COM ----- Terminal for selecting Manual resistors FA1-1007
 GND ----- Ground or Earth
 H ----- Voltage is high
 I-SPD --- Current flow to SPD
 L ----- Voltage is low
 MD ----- Motor drive
 MG ----- Magnet (Electromagnet or combination magnet)
 SW ----- Switch
 V-AUTO -- Output voltage for automatic shutter control
 Vcc ----- Power supply voltage
 V-COM --- Voltage of COM

4-2 Checking Lands and External Figures of Main Parts

4-2-1 FPC 1 #1001 (Checking lands)

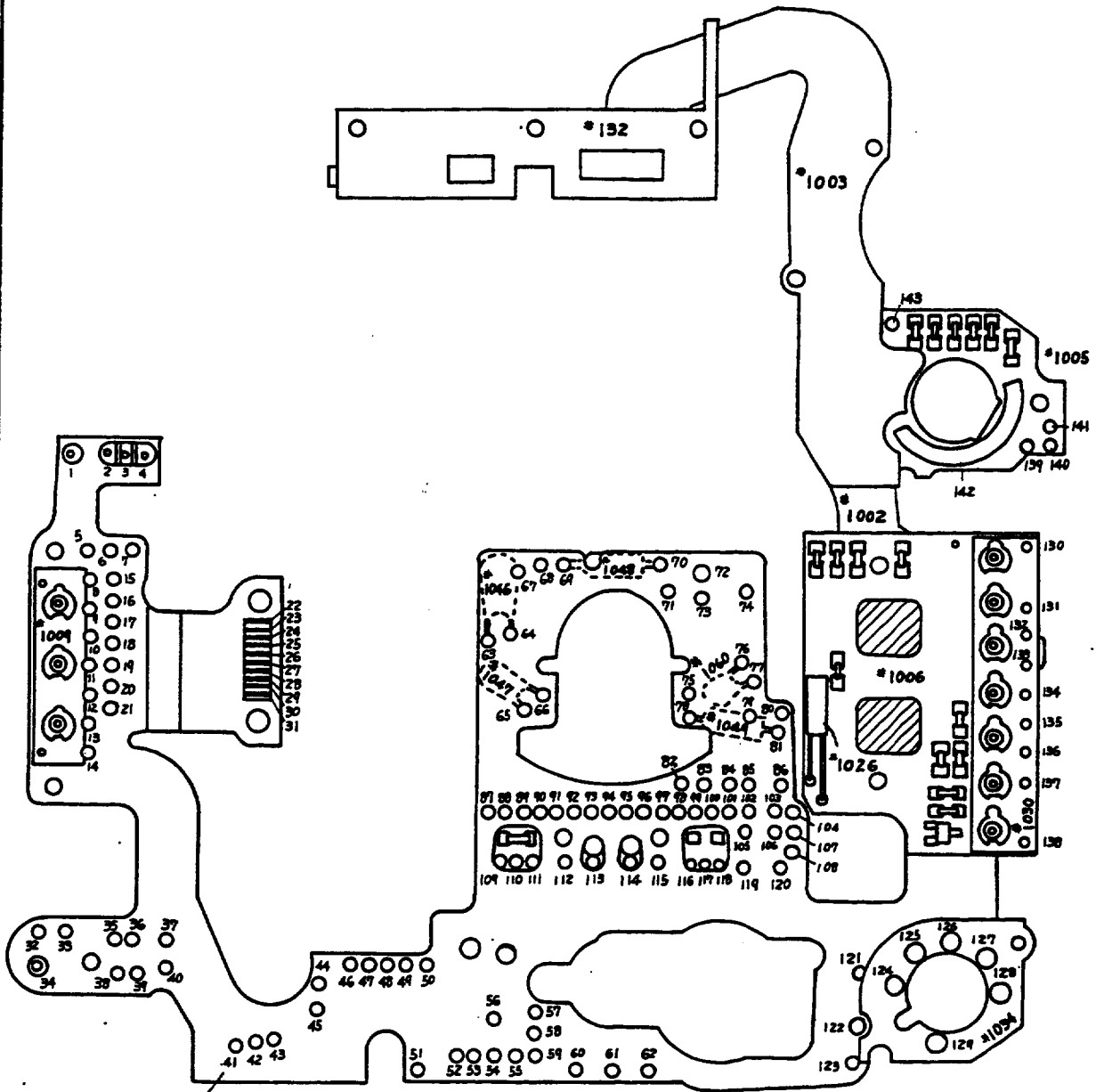

For example, this checking land is called F-41.

fig. 1

#1001-1

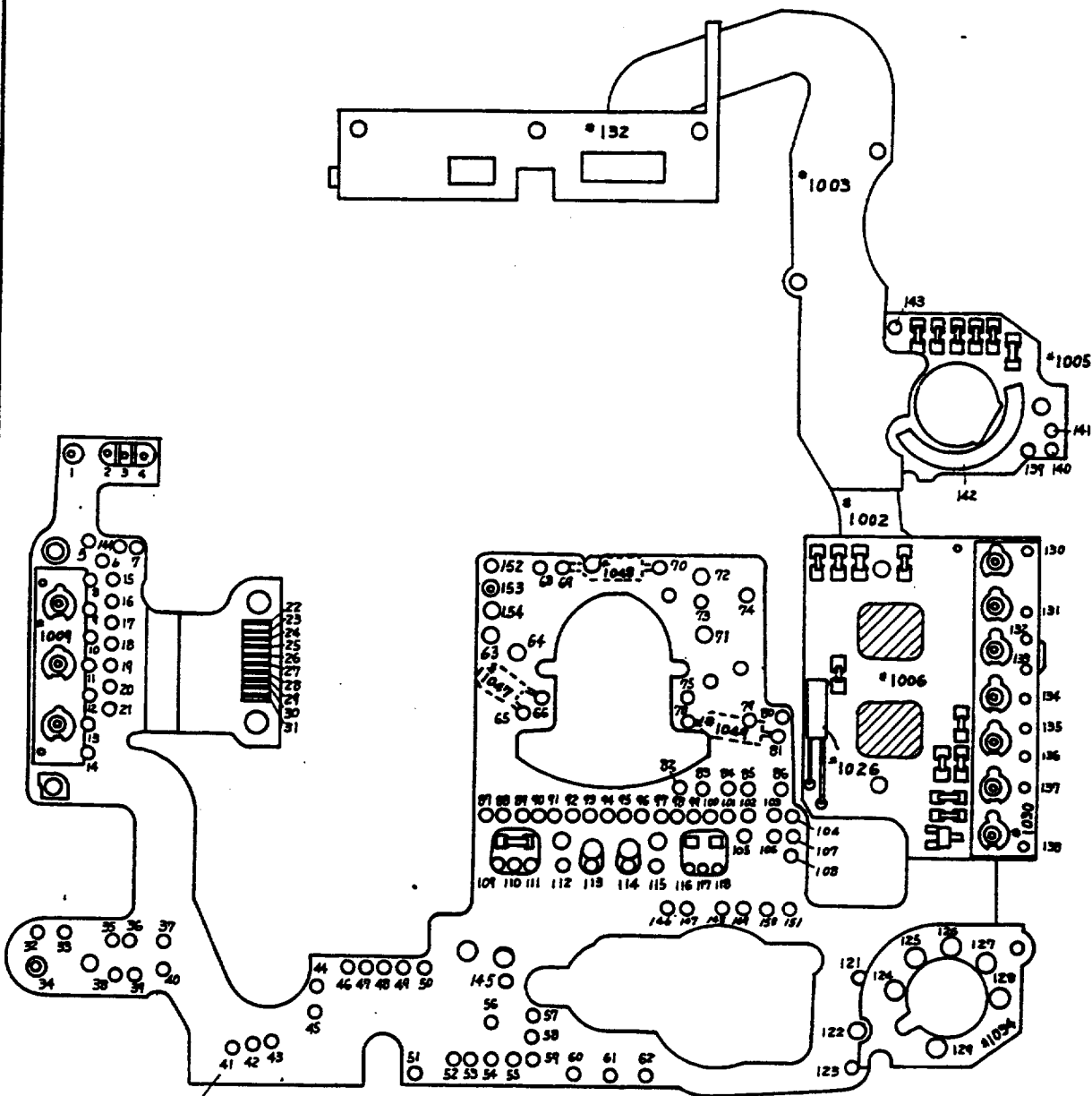

For example, this checking land is called F-41.

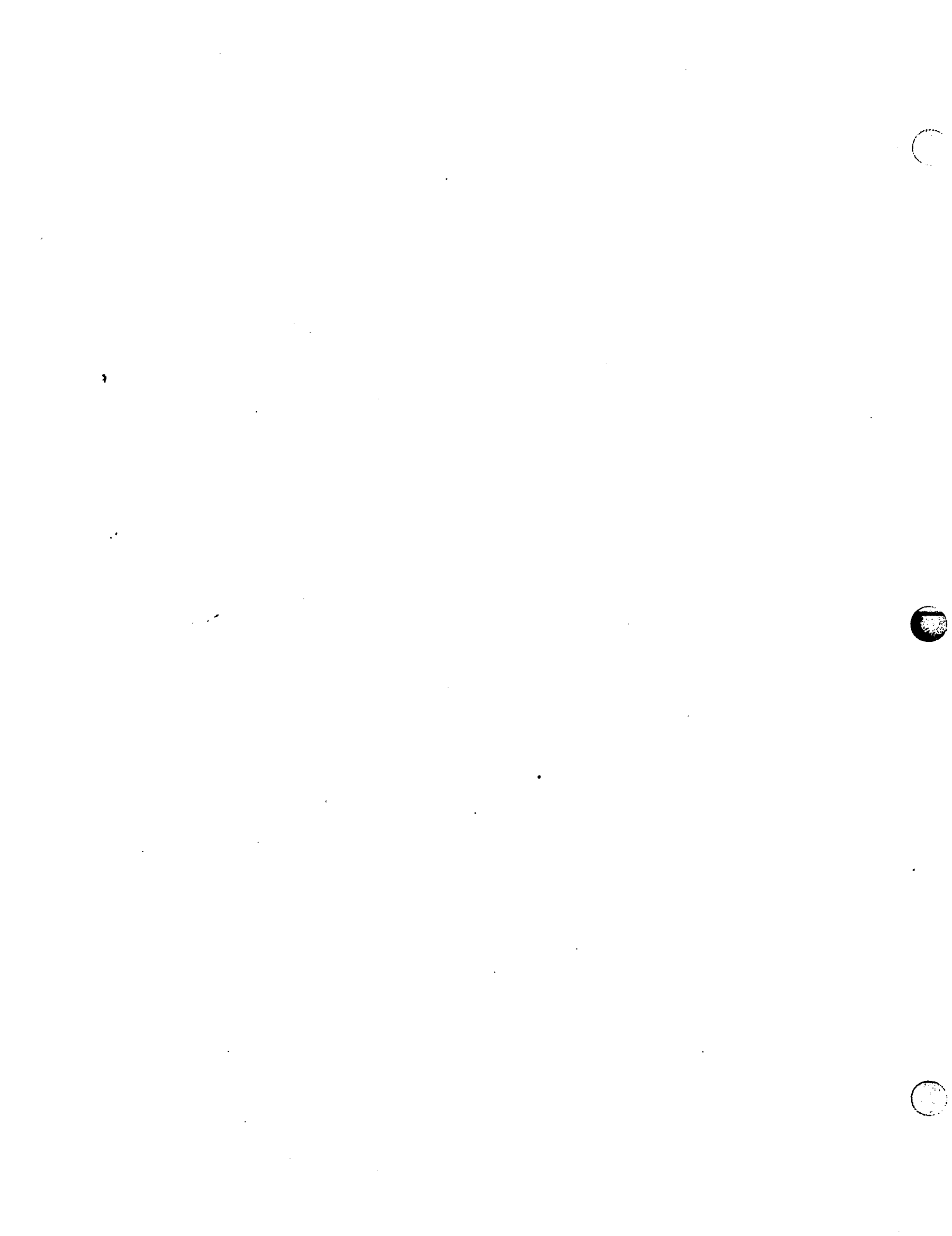

4-2-3 Ceramic, exposure information #1004 (Checking lands)

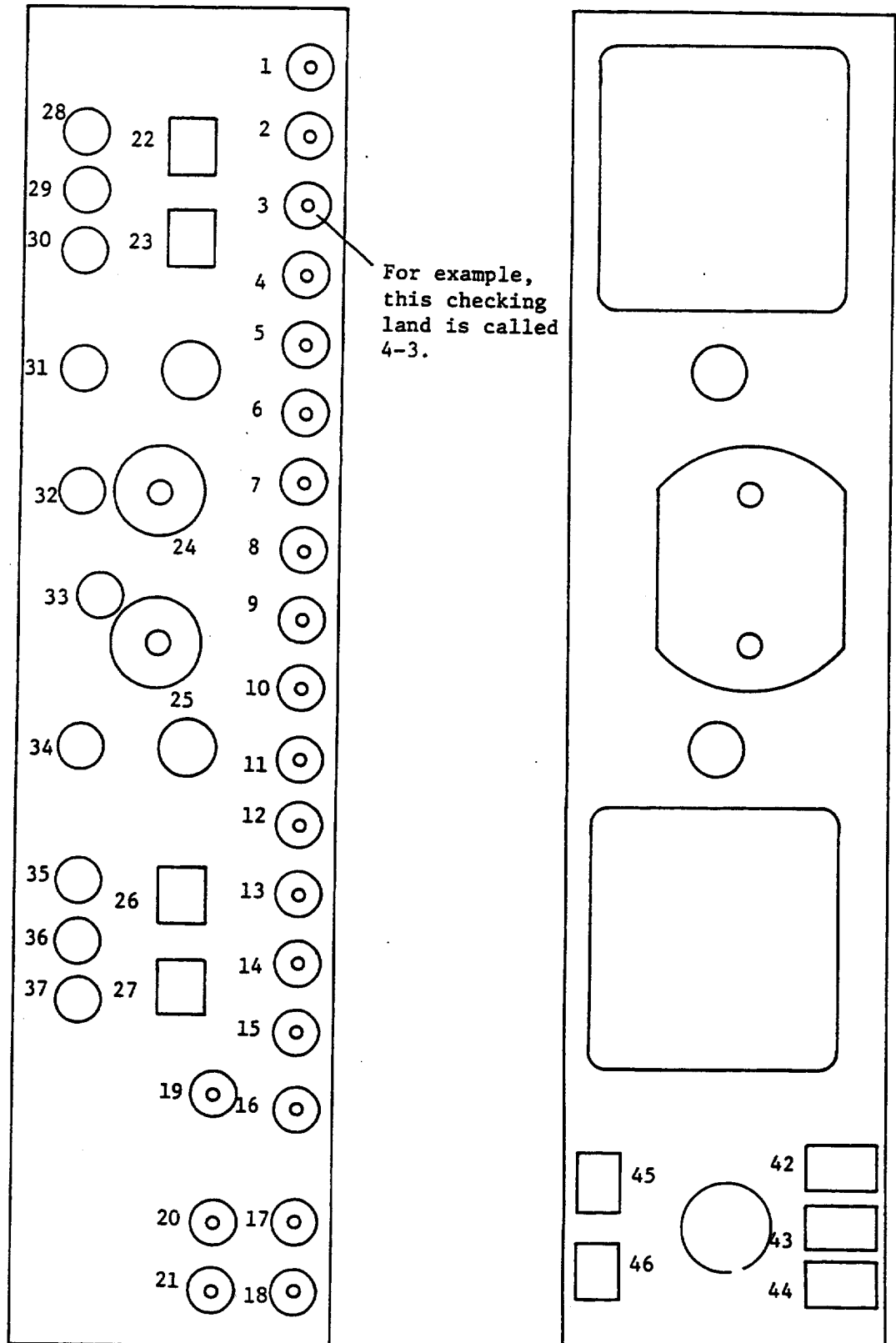

fig. 3

4-2-4 Ceramic, exposure information #1004 (External figure)

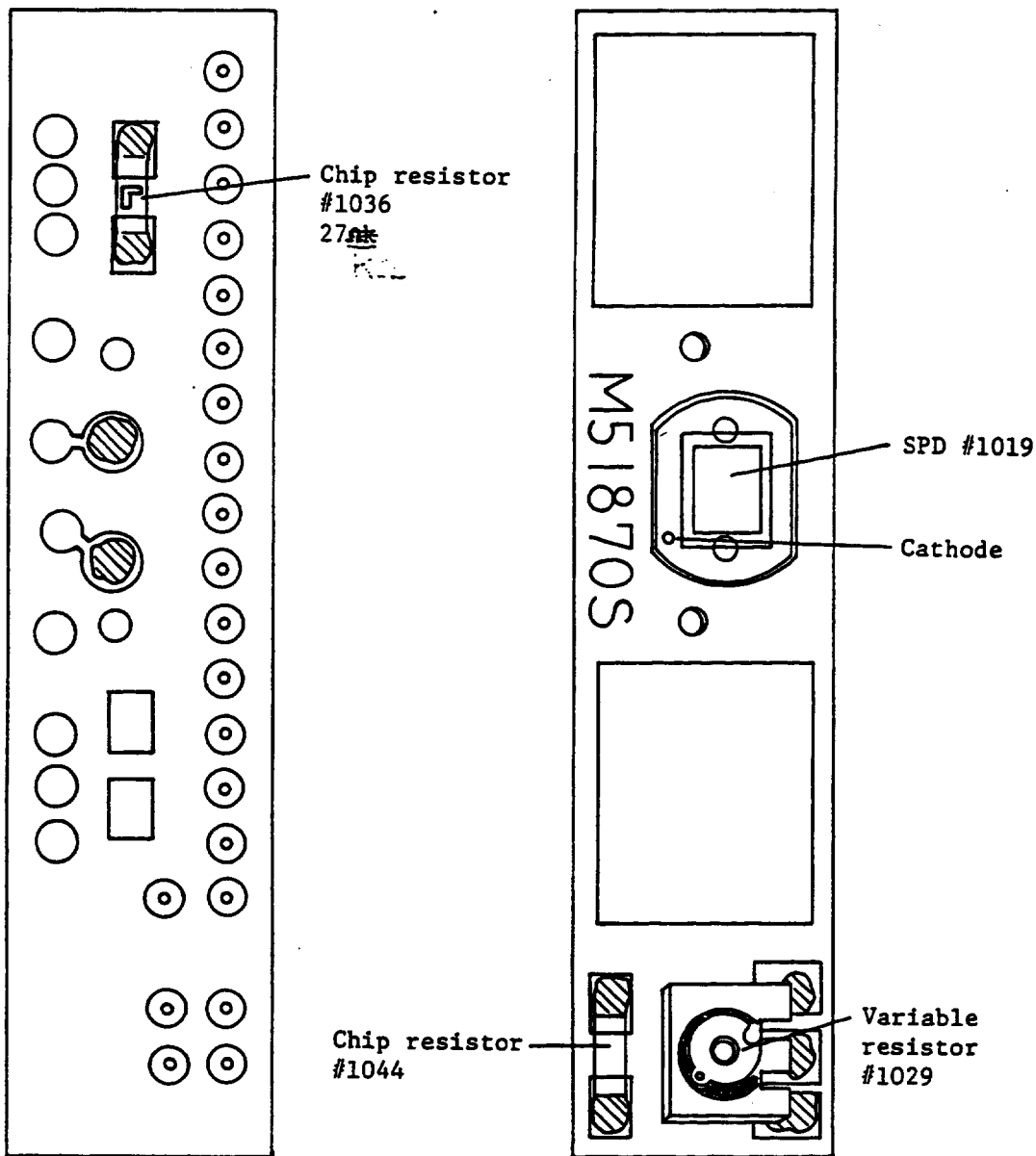
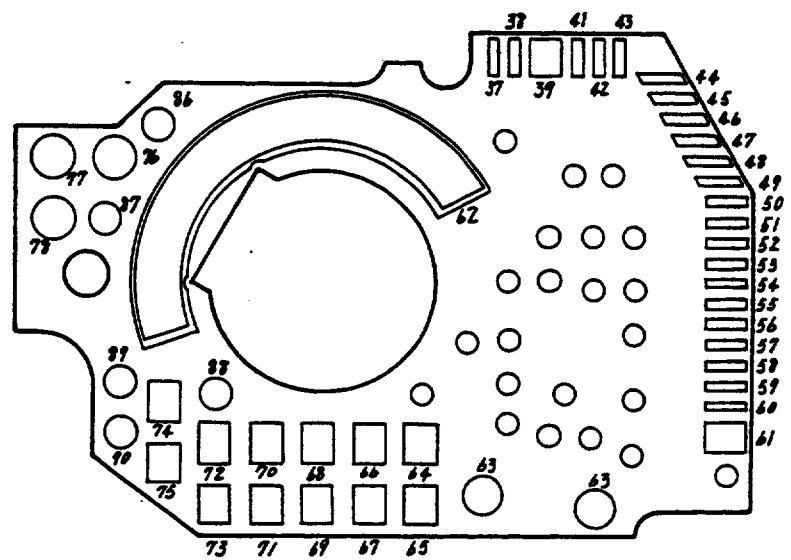
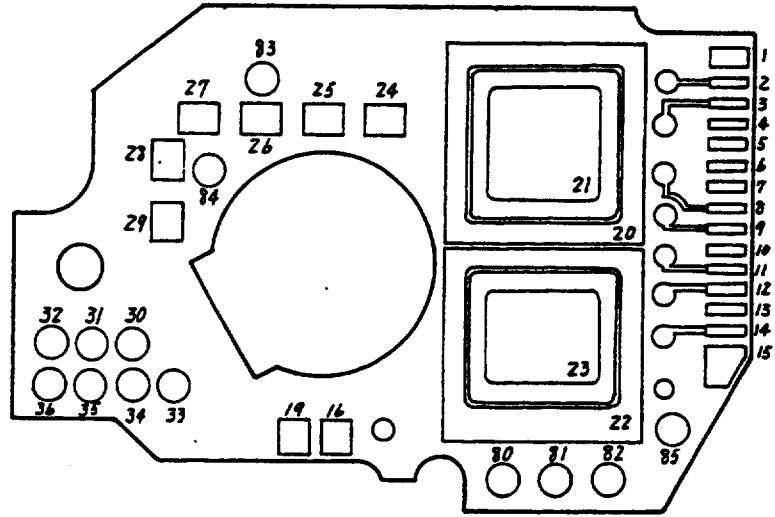

fig. 4

#1005-1





4-2-5 Ceramic, LCD #1005 (Checking lands)

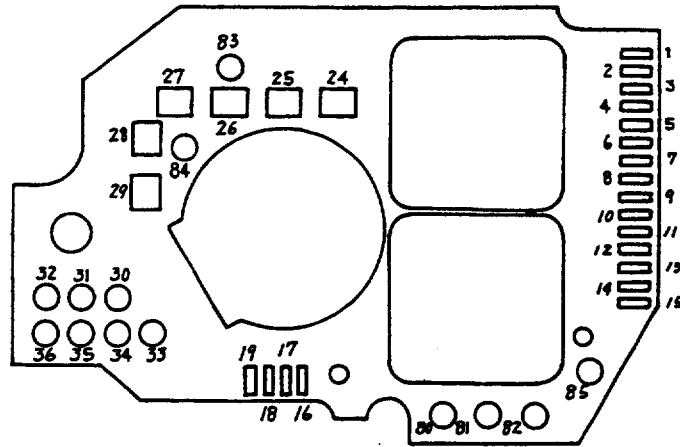

For example, this checking land is called 5-80.

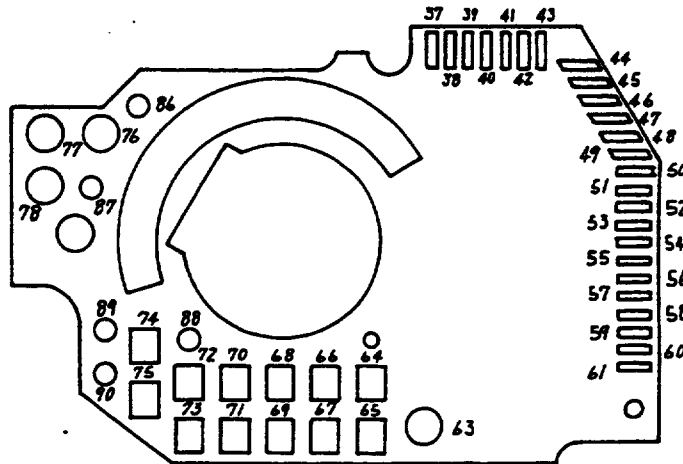

fig. 5

4-2-6 Ceramic, LCD #1005 (External figure)

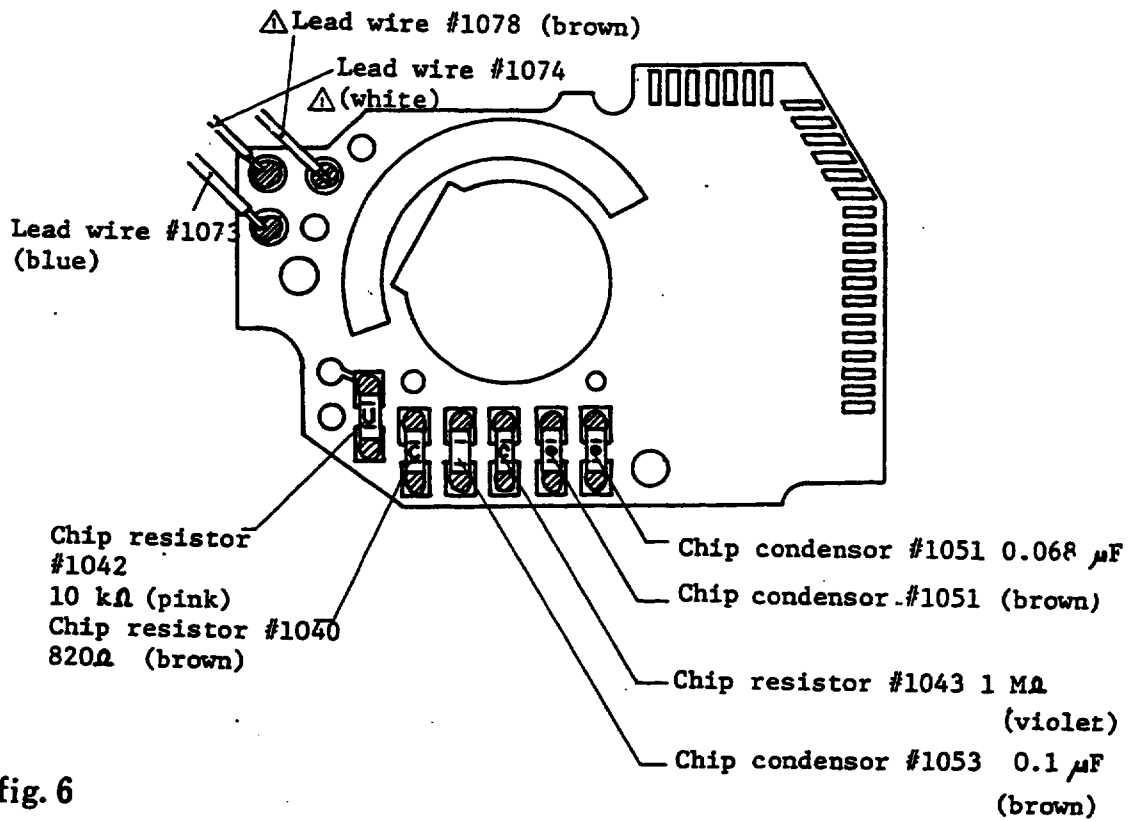
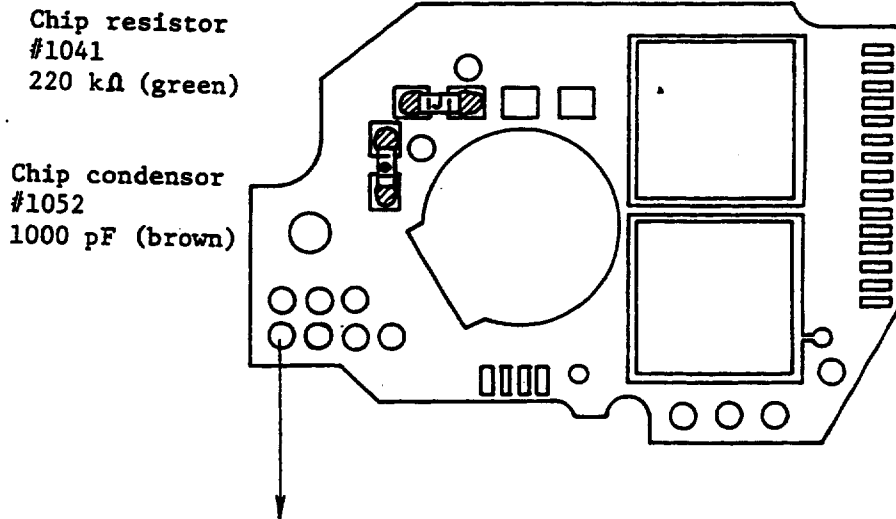
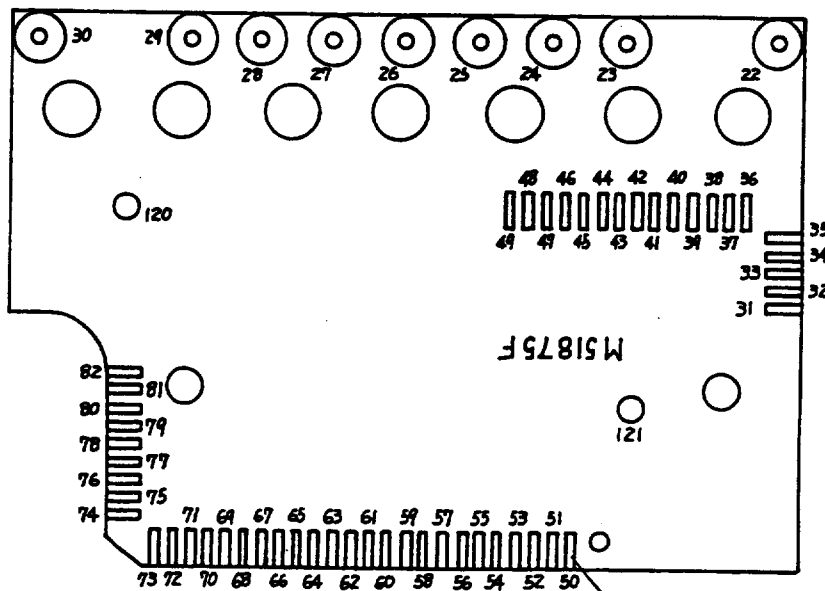
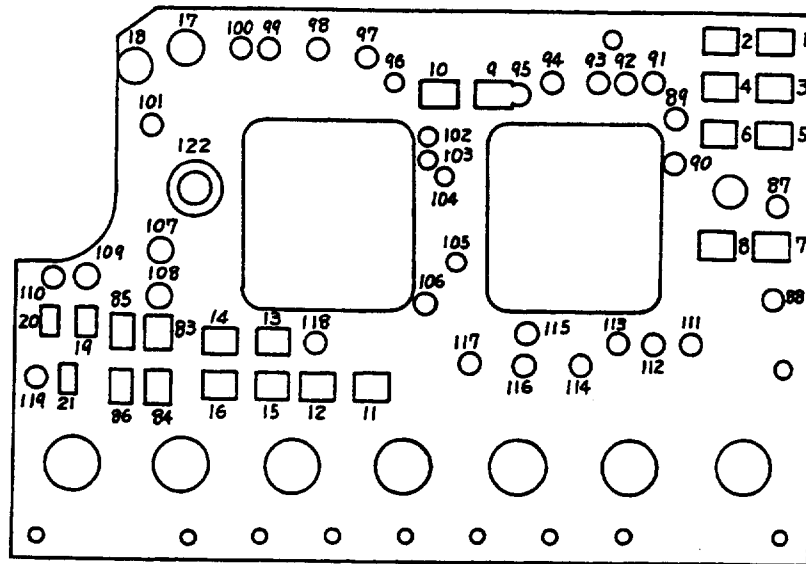

fig. 6

4-2-7 Ceramic, Quartz Oscillator #1006 (Checking lands)



For example, this checking land is called 6-50.

fig. 7

4-2-8 Ceramic, Quartz Oscillator #1006 (External figure)

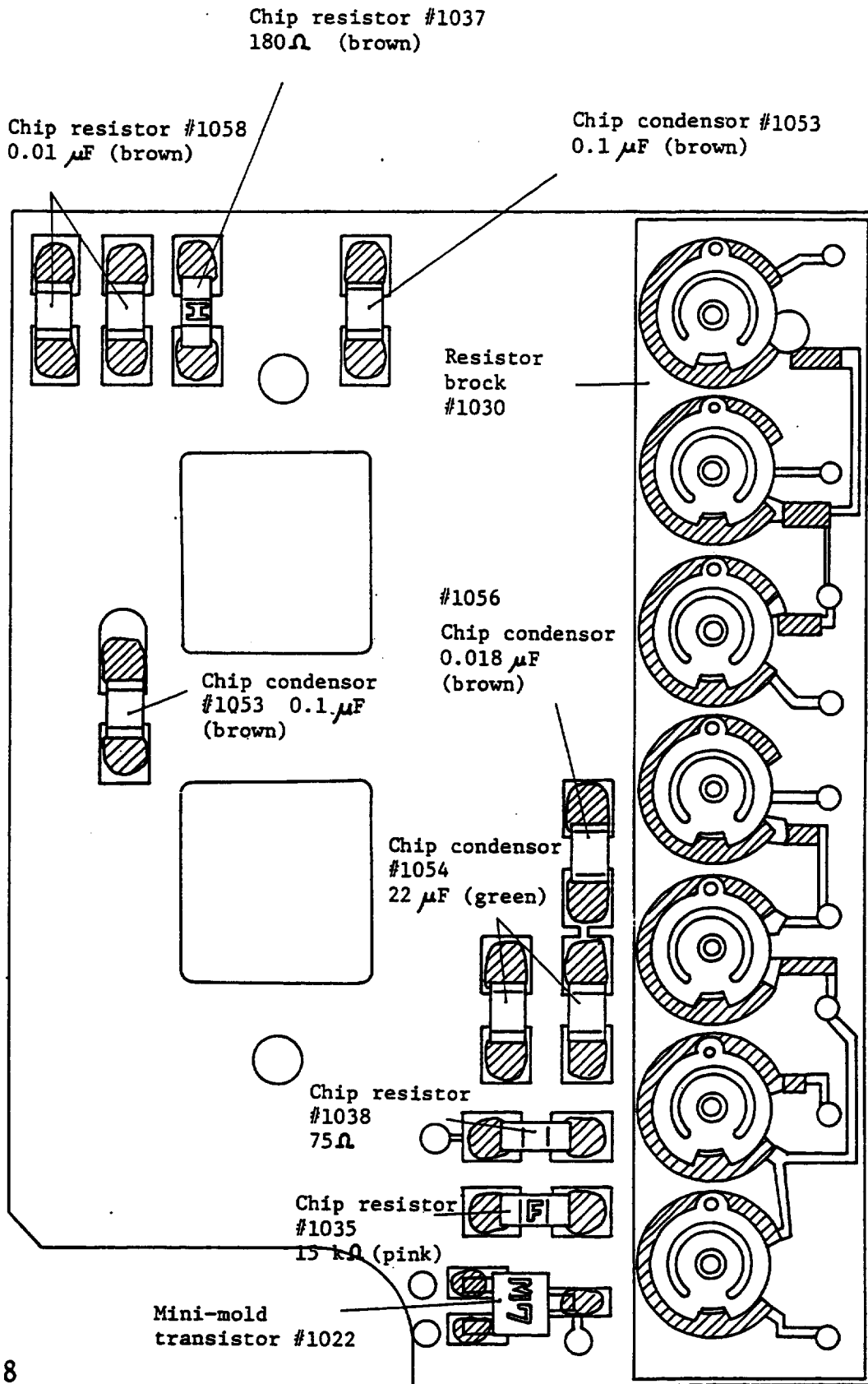
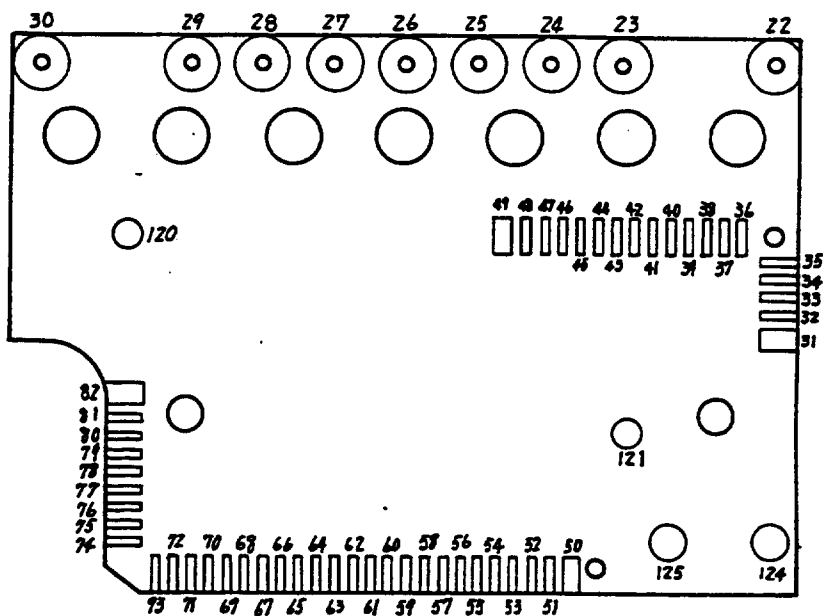
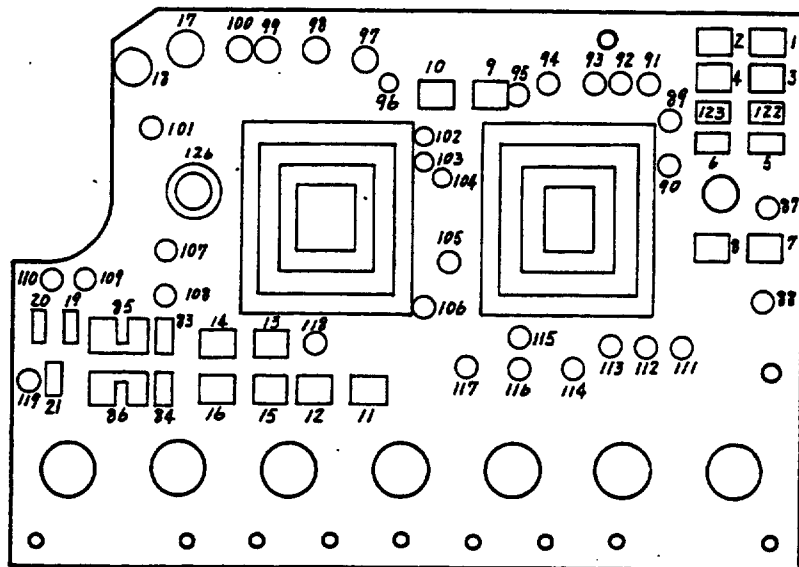

fig. 8

#1006-1





#1006-1

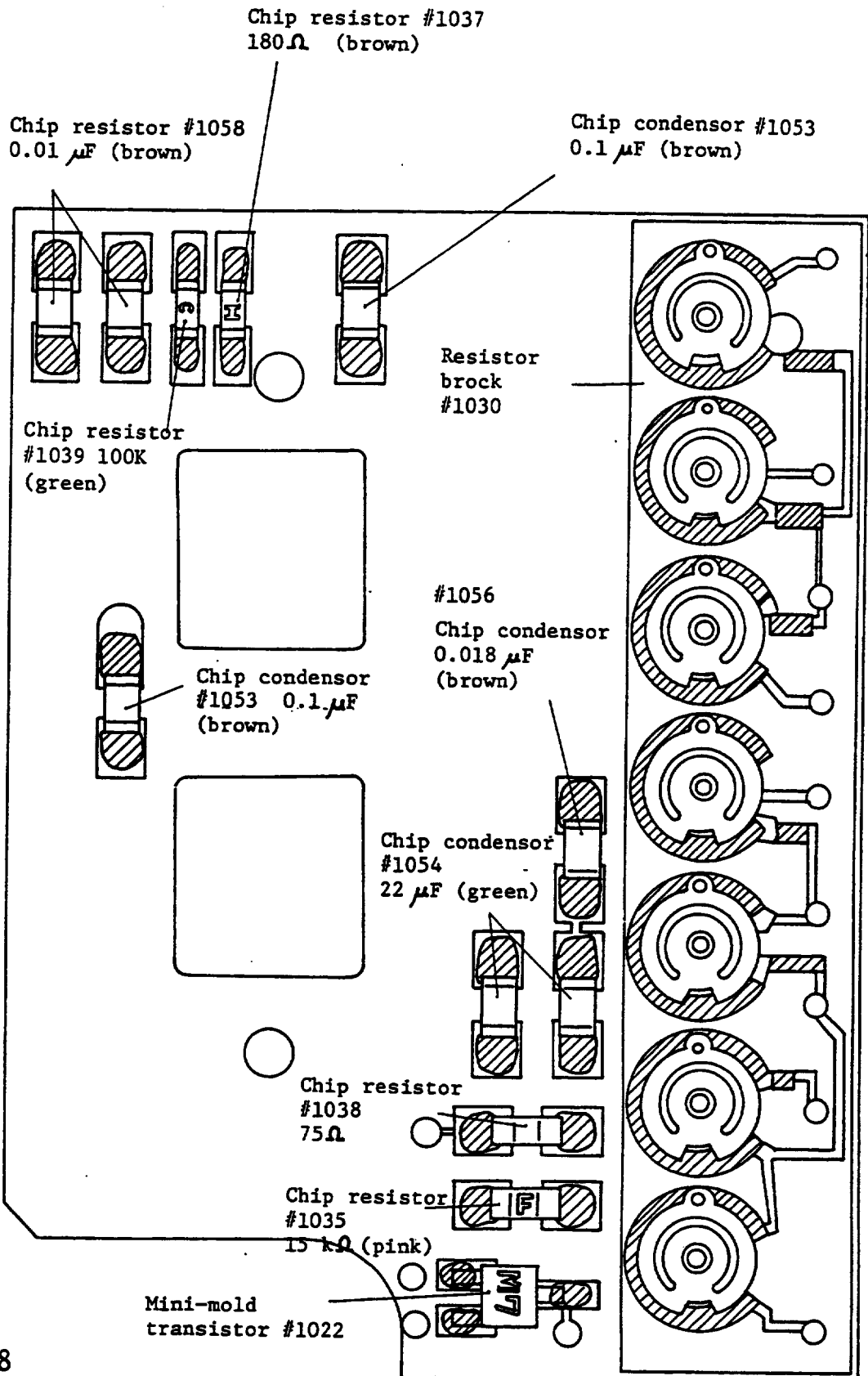

fig. 8



4-2-9 Resistor Block A #1009

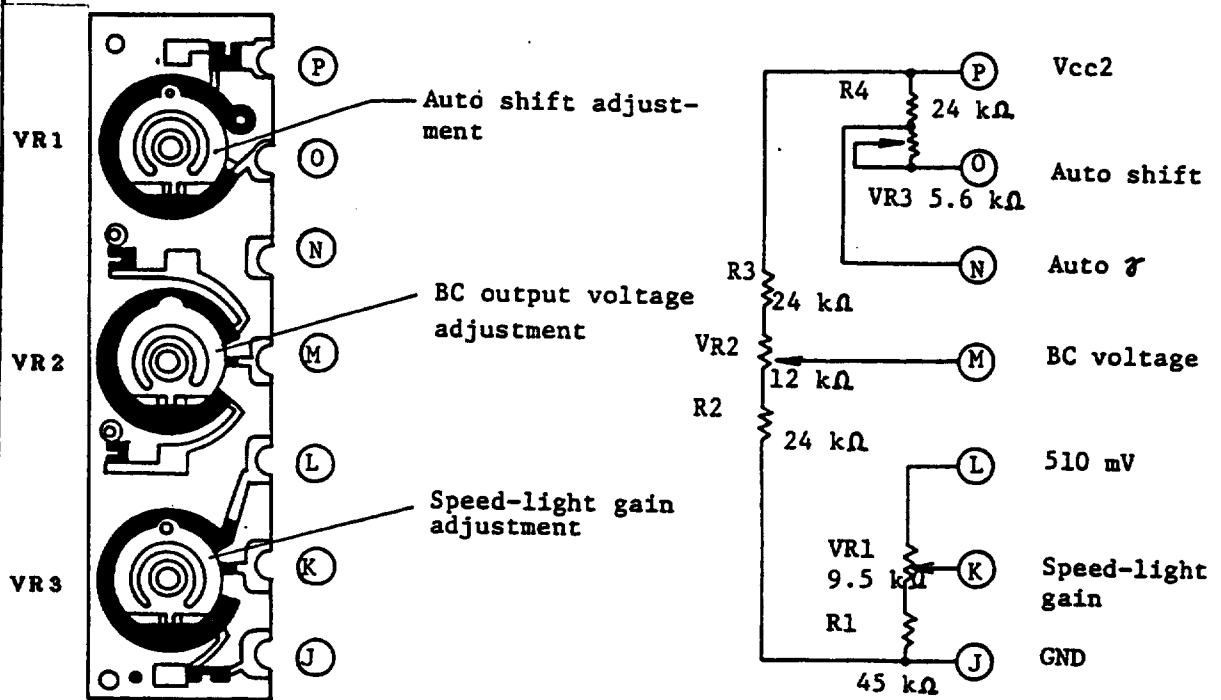

fig. 9

Note: Resistance value of VR (Variable Resistor) is shown for its maximum.

Reference Voltages of Checking Lands.

- Ⓟ 3.0 V
- Ⓞ 2.2 - 2.8 V
- Ⓝ 2.2 - 2.8 V
- Ⓜ 1.25 - 1.6 V
- Ⓛ 0.48 - 0.52 V
- Ⓚ 0.4 - 0.52 V
- Ⓝ 0 V

Turning VR1 counterclockwise shortens the shutter speed on Auto.

Turning VR2 clockwise increases BC output voltage.

Turning VR3 clockwise decreases Speed-light gain, which is a current flow to the speed-light control.

4-2-10 Resistor Block B #1030

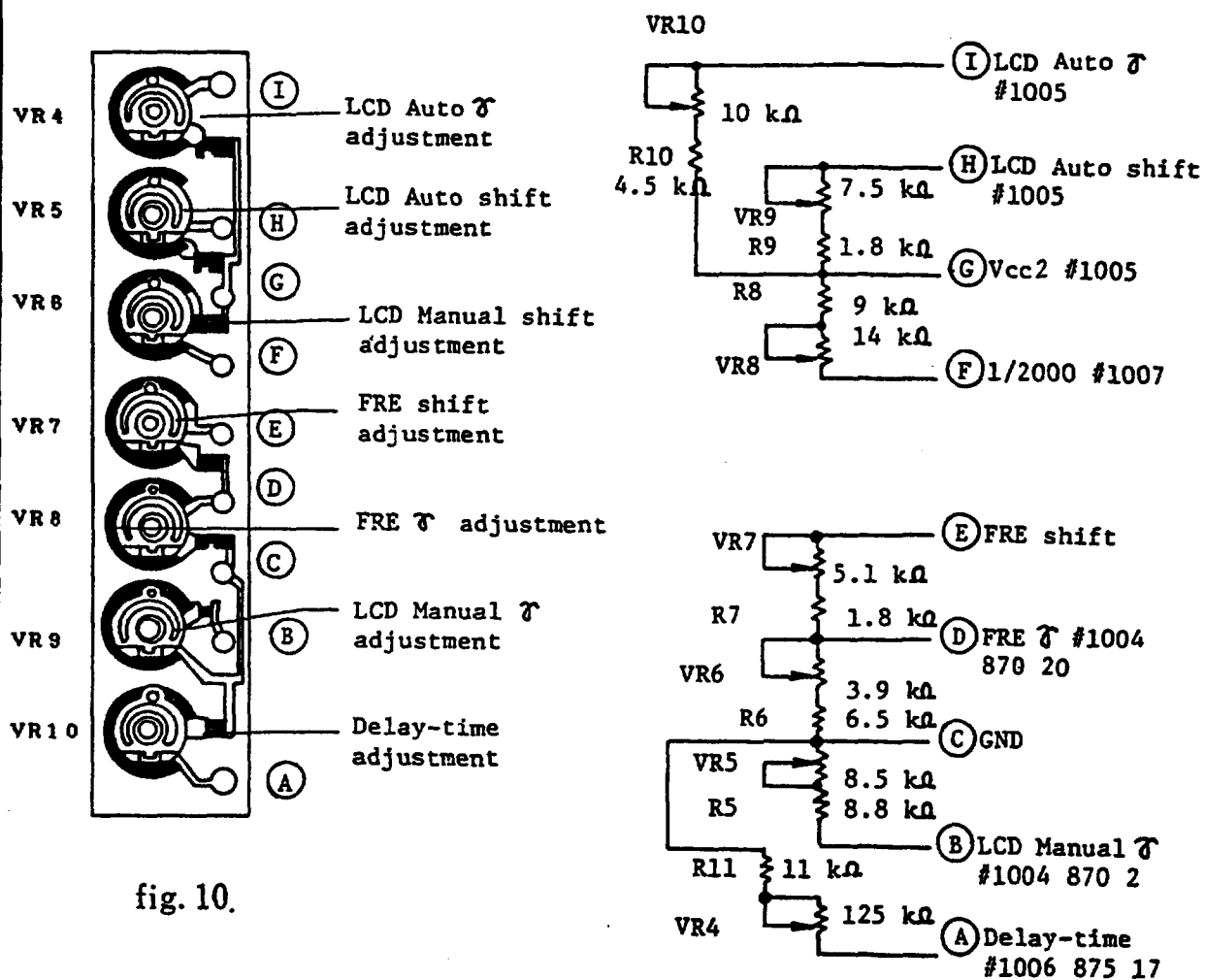

fig. 10.

Note: Resistance value of VR is shown for its maximum.

Reference Voltages of Checking Lands

- | | |
|-----------------|---|
| (A) 0.4 - 0.8 V | Turning VR10 clockwise makes the Delay-time long. |
| (B) 0.24 V | Turning VR9 clockwise reduces the coverage of the display \bar{M} on Manual. |
| (C) 0 V | |
| (D) 0.24 V | Turning VR8 clockwise reduces the FRE τ . |
| (E) 0.3 - 0.5 V | Turning VR7 clockwise slows the shutter speeds on Auto. |
| (F) 2.8 V | Turning VR8 counterclockwise changes the coverage of the display \bar{M} on Manual in the order of. $\bar{M} \rightarrow \bar{M} \rightarrow \bar{M}$. |
| (G) 3.0 V | |
| (H) 2.88 V | Turning VR5 clockwise changes a display on Auto into the one of slower shutter speed. |
| (I) 2.2 - 2.8 V | Turning VR4 clockwise increases the coverage of a display of shutter speed on Auto. |

3

6

9

4-3 Outlines of Shutter Control System

4-3-1 Power Supply

- 1) Depressing the shutter release button half-way closes Power SW. It turns on Transistor #1022 to increase Vccl until Vccl is equal to Vcc2. Thus, the current flow is supplied to the whole circuit of camera.
- 2) Setting the shutter release button free opens Power SW, and the voltage of Π^3 goes high to start timing of 16 sec. for holding the circuit ON. After the lapse of 16 sec., the voltage of Timer-OFF goes high, and #1022 turns off to drop Vcc2 to 0 V. It opens the circuit.
- 3) When Vccl is equal to Vcc2 and the circuit is closed, closing Memory SW simply resets the timing of 16 sec. for holding the circuit ON. Thus, the timing of 16 sec. will not start again before Memory SW opens.
- 4) For instance, first Power SW opens in 5 sec. after its closing. Then Memory SW closes in 10 sec. after this Power SW opening. Memory SW also opens in 10 sec. after its closing. From this moment, Vccl will reach Vcc2 in 16 sec.. Totally, it is 41 sec. from closing of Power SW to dropping of Vcc2 to 0 V.
- 5) When timing 16 sec., releasing the shutter closes Shutter SW and resets the timing of 16 sec.. Then, after Mirror moves down to the viewing position, the circuit is held closed in 16 sec..
- 6) While the LCD remains ON, the circuit is being closed or Vccl is held equally to Vcc2.
- 7) Opening Power-lock SW holds Power SW and Release SW open. Subsequently, during timing of 16 sec., opening Power-lock SW will not turn off the LCD.
- 8) When the MD is mounted, the power supply connector of MD pushes up MD switch #37 and cancels the power supply from the batteries installed in camera. In this way, MD supplies Vccl to the circuit of camera.

fig. 11 Power circuit

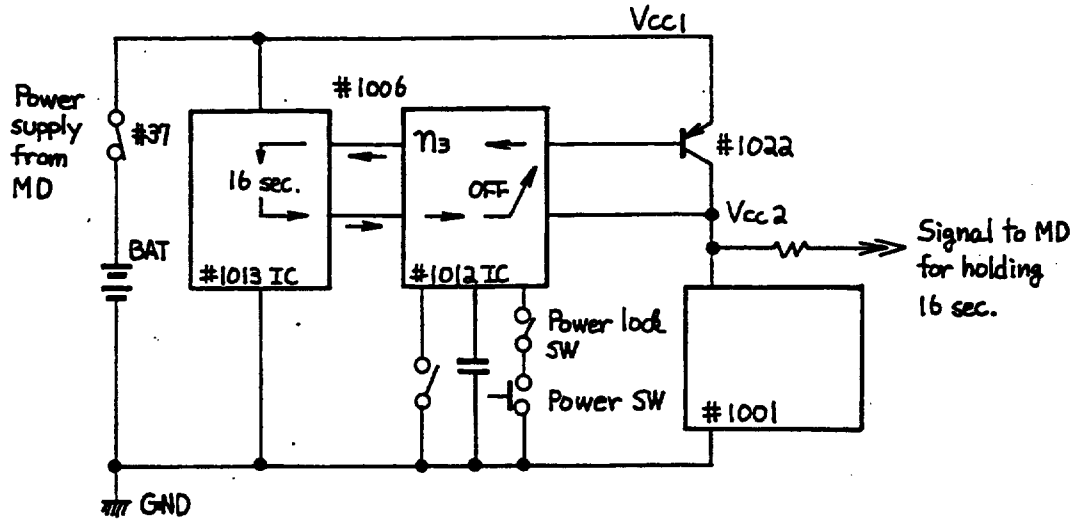

fig. 12 Timing chart of power circuit

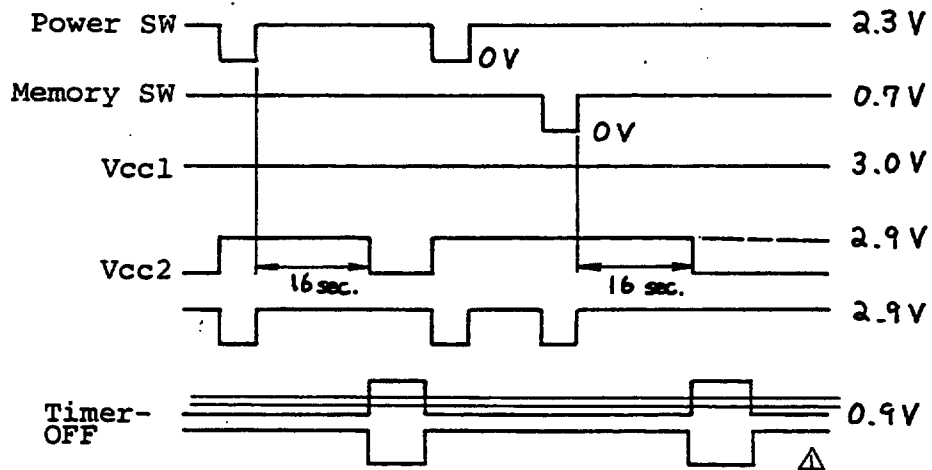

table 1 Checking lands in power circuit

Power SW ----- F-7 F-33 6-52

Memory SW ---- F-19 F-58 6-70

Vcc1 ----- F-2 F-15 F-61 F-122 6-50 6-110

Vcc2 ----- F-8 F-20 F-40 F-59 F-65 F-69 F-92 6-1 6-86 6-119 6-68

η_3 ----- 6-116

Timer-OFF ---- 6-112

4-3-2 Shutter Release

- 1) Shutter release operation depends on the following conditions;
 - a The voltage of the installed batteries should be more than 2.45 V.
 - b Shutter SW opens. (Mirror is not locked up to the taking position)
 - c Film-advance completion SW and Closing curtain SW open. (Film-advancing is completed)

- 2) Depressing the shutter release button closes Release SW, and the transistor on #1092 becomes ON. Next, the voltage at #1013 goes low to supply the output for shutter releasing.

- 3) At this moment, if the above conditions are fulfilled, the voltage of Combination MG for shutter release goes low to draw the current from Condensator #1046. It clears the magnetic power of Combination MG to free the release lever for shutter curtains travel.

- 4) When Power SW is already closed by depressing the shutter release button half-way and Vcc2 reaches 3V, closed Release SW drops direct the voltage of Combination MG. However, when both Power SW and Release SW simultaneously are closed by depressing the shutter release button all the way at first hand, it takes approx. 62.5 ms to drop the voltage of Combination MG after closing Power SW.

- 5) In the shutter-releasing cycle, Closing curtain starts to travel. At this moment, setting the shutter release button free closes Closing curtain SW. Thus;
 - a The signal for the film-advancing is transferred to MD. (With a delay of approx. 20 ms, the MD works)
 - b Condensator #1046 is charged.
 - c The next shutter release is locked.

- 6) However, when the shutter release button is held depressed and Release SW remains closed also after completing the shutter release, Closing curtain SW cannot be closed to perform the above three operations 5-a, 5-b and 5-c.

- 7) Under these conditions, the film-advancing first closes Film-advance completion SW, and then opens Closing curtain SW. After completing the film-advancing, Film-advance completion SW opens. Thus, the condition 1-c is ready. And if the conditions 1-a and 1-b are fulfilled, the next shutter releasing is possible.

- 8) When the shutter is released by MD, the signal from the MD direct drops the voltage at the collector of the transistor in #1092.

fig.13 Shutter release circuit

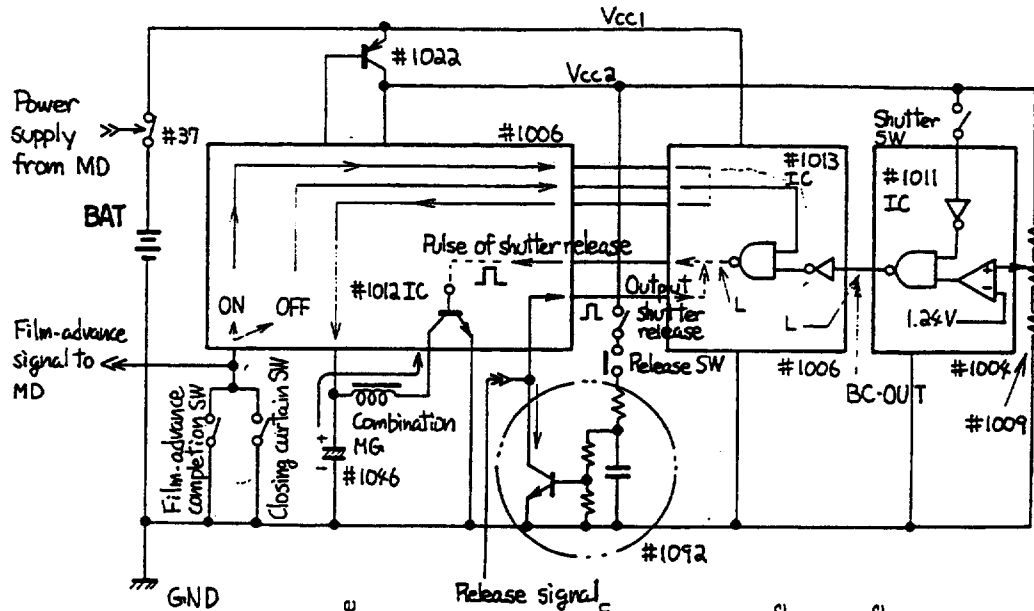

fig.14 Timing chart of shutter release circuit

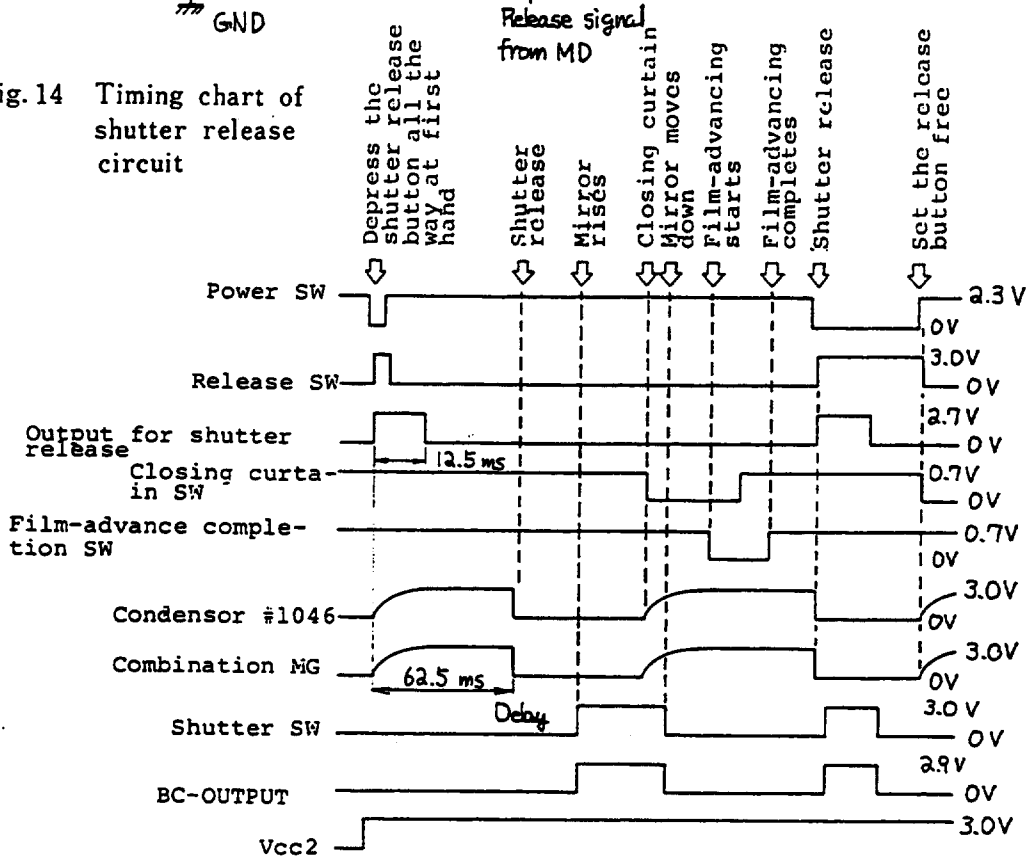

table.2 Checking lands in shutter release circuit

Release SW	-----	F-6	F-32	F-125	6-10	6-51
Release output	---	6-94			BC OUTPUT	----- F-106 6-80 6-85
Closing curtain SW	-----					
Film-advance completion SW	-----	F-4	F-34	F-62	F-129	6-65
Combination MG	----	F-17	F-44	6-63	6-98	
Condensator #1046	----	F-18	F-45	6-59	6-96	

4-3-3 Auto Shutter Speed Control

- 1) A light through the mounted lens and the half-mirrored area of the main mirror reflects on the metering mirror, and reaches the SPD (Silicon Photo Diode) located in the bottom of camera body. SPD changes the light energy into the current flow. The current flow is converted through the logarithmic time compression circuit into the voltage, which reacts to 18 mV per 1 LV. The brighter the light striking SPD, the greater the current flow.

On the other hand, turning the ASA dial and the aperture coupling ring changes the resistance value of the FRE (Functional Resistor). The slower the film speed or the smaller the f-stop, the higher the output voltage of FRE.

- 2) In the computing of the output voltages from SPD and FRE, the output voltage for auto shutter speed control (V-AUTO) is adjusted, which reacts 36 mV per 1 EV. The brighter the light, the higher the film speed, or the larger the f-stop, the higher the V-AUTO. The maximum voltage is 2.8 V, and the minimum is 2.2 V. See Notice 1.

$$\text{Voltage[SPD]} - \text{Voltage[FRE]} = \text{Voltage for Auto-control}$$

- 3) See Figure 16 , Timing chart for auto shutter speed control. Depressing the shutter release button closes Release SW and drops the voltage of Combination MG. Simultaneously, the signal for Analog SW flows to open Analog SW, and V-AUTO is held by Memory capacitor. See Notices 2 and 3. After this step, V-AUTO will not react to the changes in the light, film speed and f-stop.
- 4) As soon as Mirror is rising to the taking position, Shutter SW closes. And the current flows to Electromagnet for Closing curtain to absorb Armature #316. Thus, it holds Closing curtain open. At this moment, the terminal negative of Timing capacitor and the terminal positive of Comparator holds the voltage equal to Vcc2.
- 5) Turning Shutter curtain control #261 opens Trigger SW, and it puts the circuit of Delay-time in operation. See Notice 4. Thus, the signal of Trigger-OFF, after a delay of from 0.5 to 2.5 ms, flows to charge the Timing capacitor, and the voltage at the terminal positive of Comparator goes low. See Notice 5.

fig. 15 Auto shutter speed control circuit

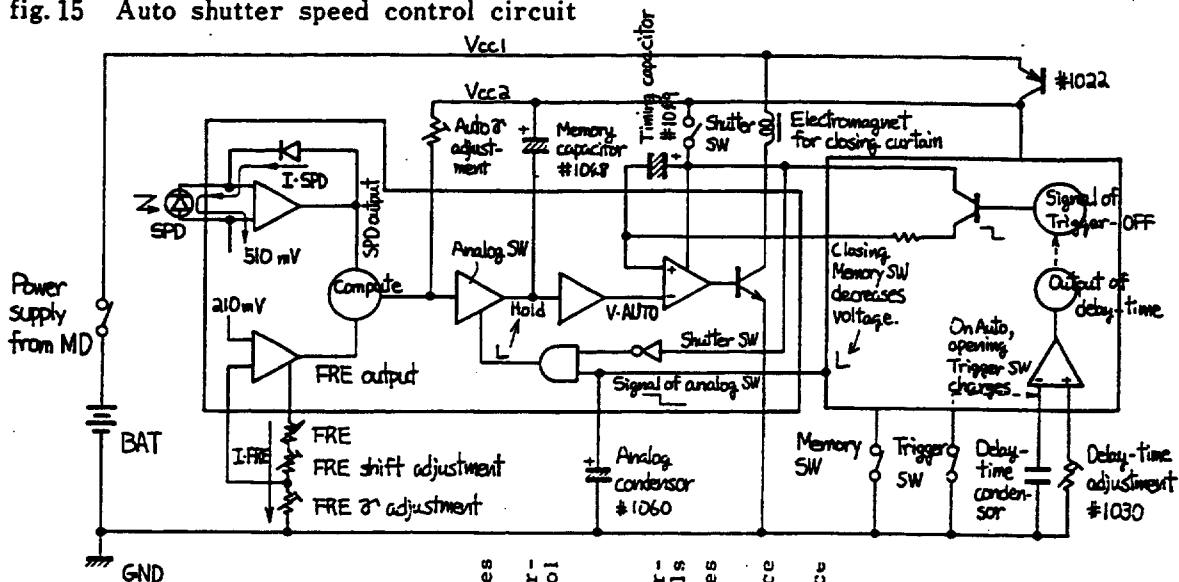

fig. 16 Timing chart of auto control circuit

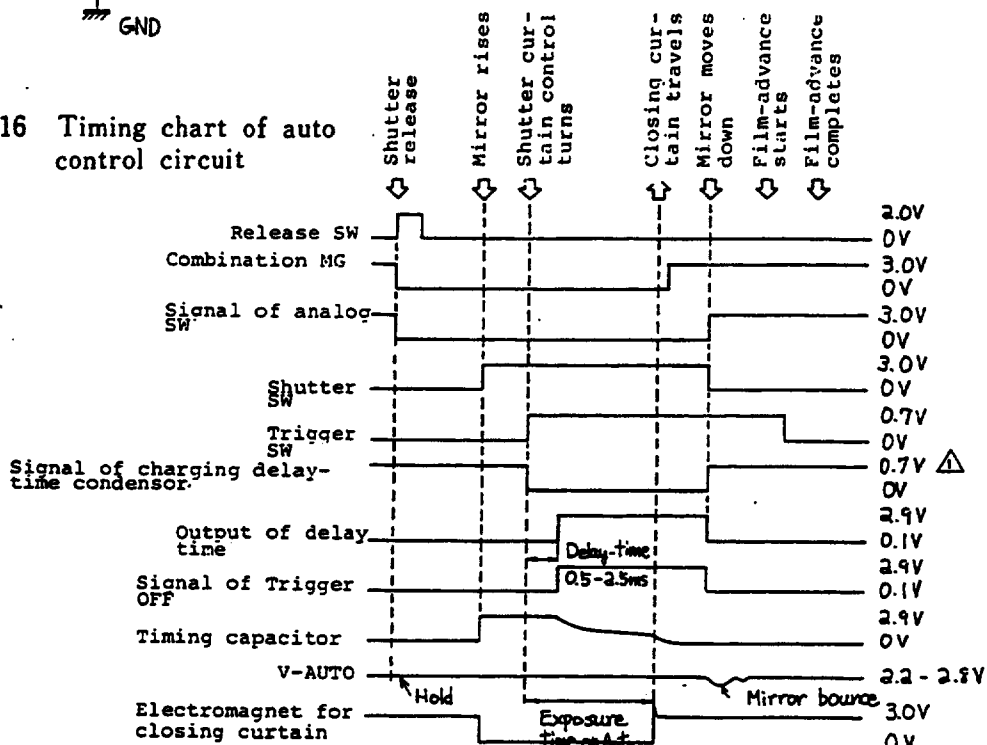
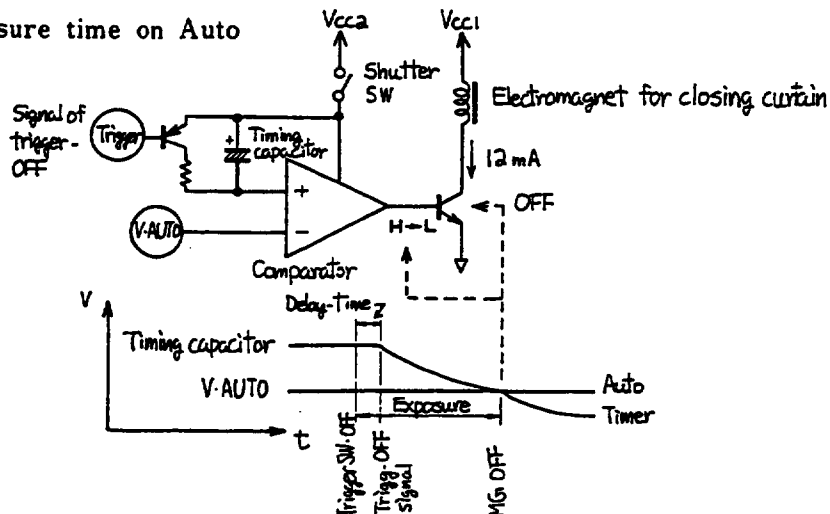

fig. 17 Exposure time on Auto



- 6) When the input voltage goes lower than V-AUTO, the output voltage of Comparator also goes low to turn off the transistor, which supplies the current flow to Electromagnet for Closing curtain. So, Electromagnet loses magnetic power and frees Hook #292 to start the closing curtain travel.
- 7) After the exposure, Mirror moves down to open Shutter SW. And Analog SW closes. Thus, V-AUTO will react to the light, the f-stop and the film speed.

[Notice]

- 1 When measuring V-AUTO, read the value in reference to Vcc2. For instance, it reads from - 0.2 to - 0.8 mV in reference to Vcc2. When using the ground as a reference, the voltage reading varies at the control of Electromagnet for Closing curtain.
- 2 Analog SW functions as Mirror SW of the FE.
- 3 V-AUTO is held high also when Memory SW closes.
- 4 Delay-time makes a balanced timing in the sequence of shutter release as below;
 Trigger SW·OFF → Opening curtain's travel → Electromagnet for Closing curtain·OFF → Closing curtain's travel
 The time from Trigger SW·OFF to Opening curtain's travel is longer than that of Electromagnet·OFF to Closing curtain's travel. In order to make a balance between them, Delay-time, which is from Trigger SW·OFF to Signal of Trigger SW·OFF, delays the closing curtain's travel. Note that Signal of Trigger SW·OFF functions as Trigger SW·OFF of the FE.
- 5 In the observation of wave form of V-AUTO in an oscilloscope, the shape of the wave form shakes after Shutter SW opens. It is caused by the shock of the mirror's bounce, which affects the light to SPD.

table 3 Checking lands in auto control circuit

Release SW -----	F-6 F-32 F-125 6-10 6-51
Combination MG -----	F-17 F-44 6-63 6-98
Signal of analog SW -----	F-77 F-79 F-83 F-99 F-127 6-74
Memory SW -----	6-70
Shutter SW -----	F-21 F-57 F-78 F-87 6-3 6-71
Trigger SW -----	F-3 F-60 6-53 6-91
Signal of charging delay-time condensor -----	6-99
Output of delay-time -----	6-104
Signal of Trigger-OFF -----	Nil (Collector of the transistor is 6-6 and 6-90)
Timing capacitor -----	F-81 F-103 6-5 6-87
V-AUTO -----	F-23 F-55 F-97
FRE voltage -----	F-85 F-102
SPD voltage -----	F-117 4-27 4-36
Electromagnet for closing curtain -----	F-1 F-51 F-96

table 5 Checking lands in manual control circuit

Release SW -----	F-6 F-32 F-125 6-10 6-51
Combination MG -----	F-17 F-44 6-63 6-98
Shutter SW -----	F-21 F-57 F-78 F-87 6-3 6-71
Trigger SW -----	F-3 F-60 6-53 6-91
Signal of charging delay-time condensor -----	6-99
Output of delay-time -----	6-104
Timing capacitor -----	F-81 F-103 6-5 6-87
V-AUTO -----	F-23 F-55 F-97
Gray cord V -----	F-46 F-31 6-62 6-48 5-14
W -----	F-50 F-30 6-61 6-43 5-9
X -----	F-48 F-29 6-60 6-45 5-11
Y -----	F-47 F-28 6-58 6-46 5-12
Z -----	F-49 F-27 6-57 6-42 5-8
Electromagnet for closing curtain -----	F-1 F-51 F-96

4-3-4 Manual Shutter Speed Control

- 1) Turning Shutter speed selector provides a shutter speed setting. Gray cord contact #224 comes in contact Gray cord board #1008 to input Gray cord in the circuit. See Notice 6.
- 2) In the manual shutter control, closing Shutter SW drops V-AUTO. At this moment, the voltage at the terminal negative of Timing capacitor goes high, and it follows the high output of Comparator. Thus, the transistor becomes ON to energize Electromagnet for Closing curtain. See Figure 20 .
- 3) However, at the shutter speed setting of 1/2000 sec., closing Shutter SW increases V-AUTO and the output of Comparator goes low to turn off the transistor. Thus, the current does not flow to Electromagnet.
- 4) Turning Shutter curtain control #261 opens Trigger SW. And the circuit starts to count the selected exposure time according to Gray cord. See Notice 7.
- 5) After the counting is completed, the circuit provides the operation of Delay-time by charging Delay-time condensor.
- 6) After the lapse of Delay-time, which can be adjusted from 0.5 to 2.5 ms, the output of Delay-time increases V-AUTO promptly to the value of Vcc2. Then, Comparator drops the output voltage and the transistor becomes OFF. The current does not flow to Electromagnet, to release Closing curtain.

[Notice]

- 6 Gray cord is a kind of method to input a datum in the binary notation. This has a characteristic that a cord has only one particular element to the next cord. For example, Cord Z is the element which distinguishes the speed of 1/2000 sec. from 1/1000 sec.
- 7 The shutter speed is automatically controlled to 1/80 sec. when the settings of Auto or from 1/2000 to 1/125 sec. is selected in the use of the speed-light unit. However, when the settings from 1/60 to 8 sec., Bulb and Time, the shutter simply delivers an exposure of their own speeds.

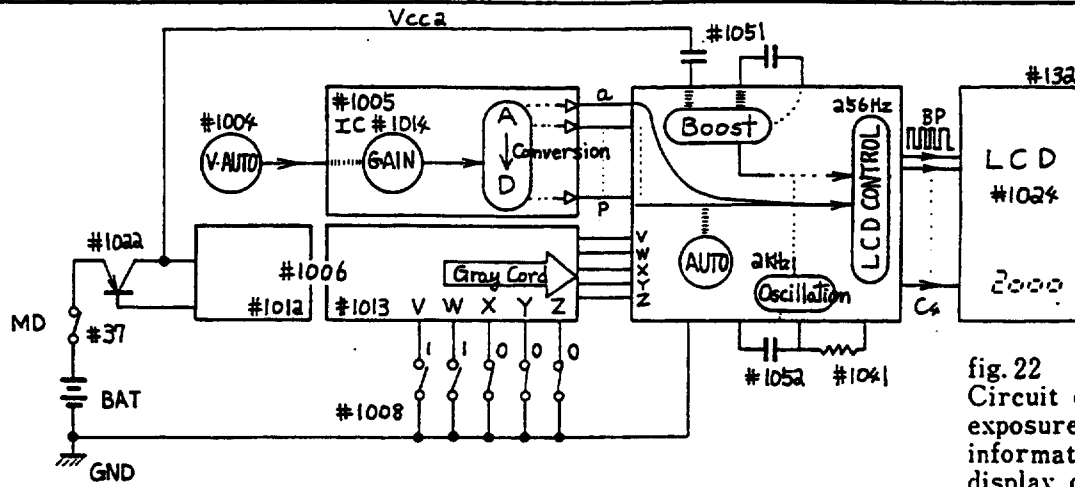

fig. 22
Circuit of
exposure
information
display on Auto

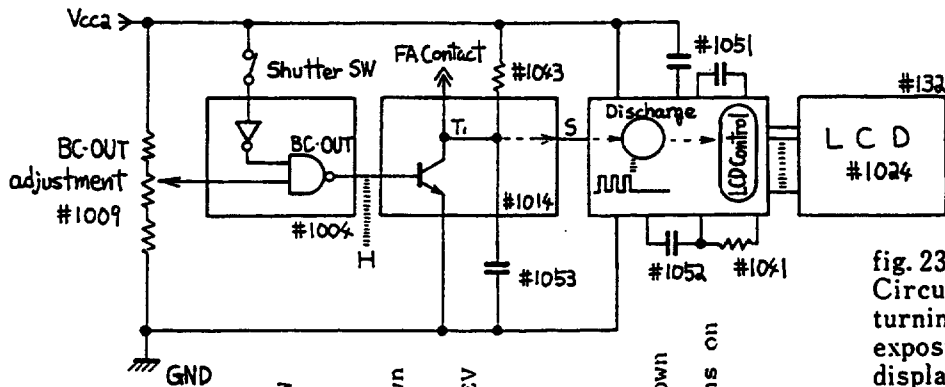

fig. 23
Circuit of
turning off
exposure information
display on Auto
and Manual

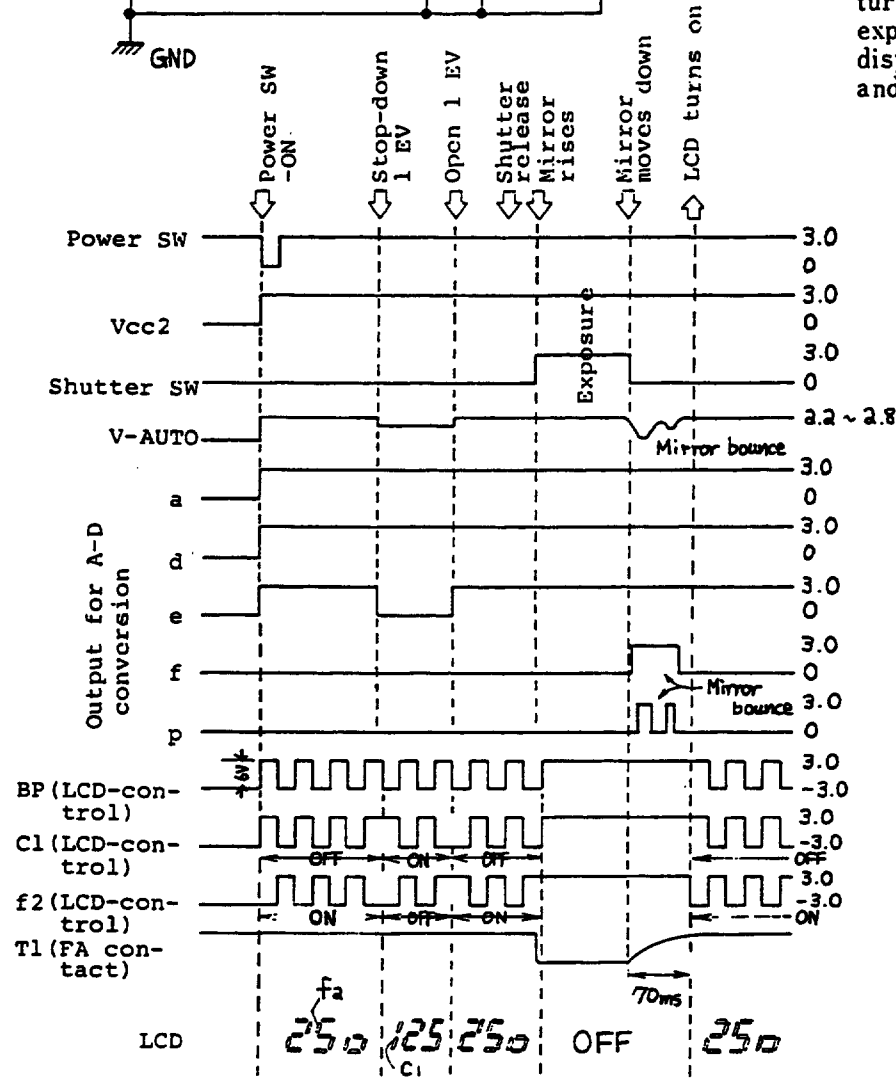

fig. 24
Timing chart
of exposure
information
display on Auto

4-3-6 Exposure Information Display on Manual

- 1) Exposure information of the manual shutter speed settings is displayed in LCD by allowing the signals of Gray cord to input in the logic circuit for operation of the circuit of LCD.
- 2) Mark of correct exposure " \bar{M}^{\dagger} " appears when the voltage of the selected shutter speed (COM) is equal to V-AUTO.
- 3) Turning the shutter speed selector moves the resistor brush on the patterns of Manual resistor #1007 to gain COM as an input, which reacts to 36 mV per 1 TV. See Notice 10.
- 4) On the other hand, V-AUTO and V-COM are computed as follows; it decides the information display of " \bar{M} ", " \bar{M}^{\dagger} " and " M^{\dagger} ".

$$V\text{-AUTO} - V\text{-COM} > \overset{\Delta}{9} \text{ mV} \rightarrow \begin{cases} \text{q goes high} \\ \text{r goes low} \end{cases}$$

$$|V\text{-AUTO} - V\text{-COM}| \leq \overset{\Delta}{9} \text{ mV} \rightarrow \begin{cases} \text{q goes low} \\ \text{r goes low} \end{cases}$$

$$V\text{-AUTO} - V\text{-COM} < -\overset{\Delta}{9} \text{ mV} \quad \begin{cases} \text{q goes low} \\ \text{r goes high} \end{cases}$$

q and r are the outputs of the two comparators which measure the level of difference between V-AUTO and V-COM. When q is low, LCD displays " \bar{M} ". When r is low, it does " M^{\dagger} ". In other words, when the difference between V-AUTO and V-COM is within $\pm \overset{\Delta}{9}$ mV, LCD displays " \bar{M}^{\dagger} ". In case V-AUTO is lower than V-COM by more than $\overset{\Delta}{9}$ mV, it displays " \bar{M} ". In case V-AUTO is higher than V-COM by more than $\overset{\Delta}{9}$ mV, it does " M^{\dagger} ".

[Notice]

- 8 The analog signal changes in sequence, however the digital signal does in discreteness.
- 9 LCD does not glow in itself. It needs the light which goes through its phase.
- 10 Manual γ adjustment decides the amperage, which flows to Manual resistor, for providing V-COM of 36 mV/TV when V-AUTO is 36 mV/EV. Manual shift adjustment decides the level of V-COM so that the mark " \bar{M}^{\dagger} " can be displayed when the shutter speed setting of 1/250 on AUTO is direct changed into that of 1/250 on Manual.

table.6 Checking lands in exposure information display on Auto

Power SW	----	F-7	F-33	6-52			
Vcc2	-----	F-8	F-20	F-40	F-59	F-65	F-69
		F-92	6-1	6-86	6-119	6-68	5-4
		5-37	5-67	5-69			
Shutter SW	--	F-21	F-57	F-78	F-97	6-3	6-71
V-AUTO	-----	F-23	F-55	F-97	5-19		
Output of A-D conversion	a	-----	5-30				
	p	-----	5-31				
T1	-----	5-36	5-63				

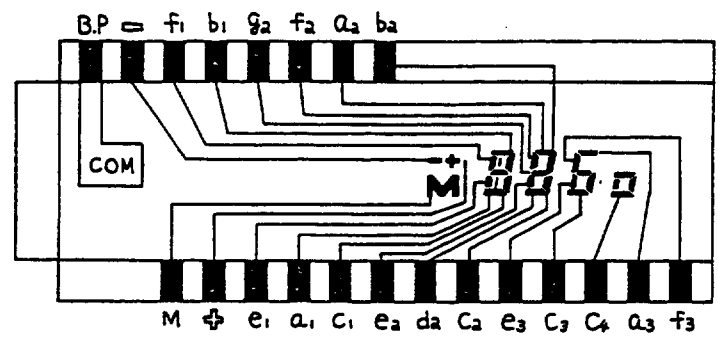
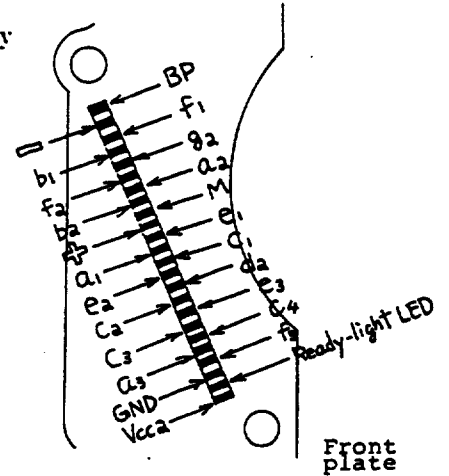

fig. 25 Checking lands in FPC3 #1003

fig. 26 LCD #1024

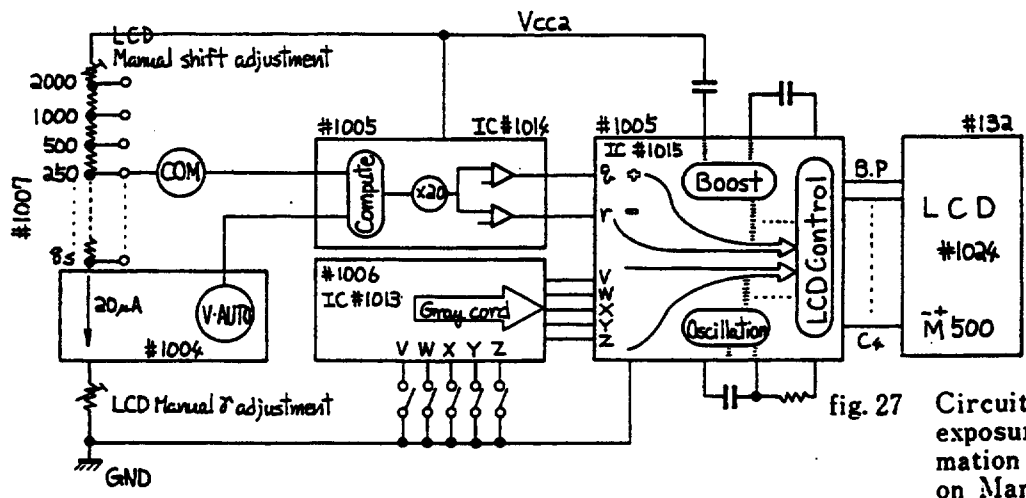
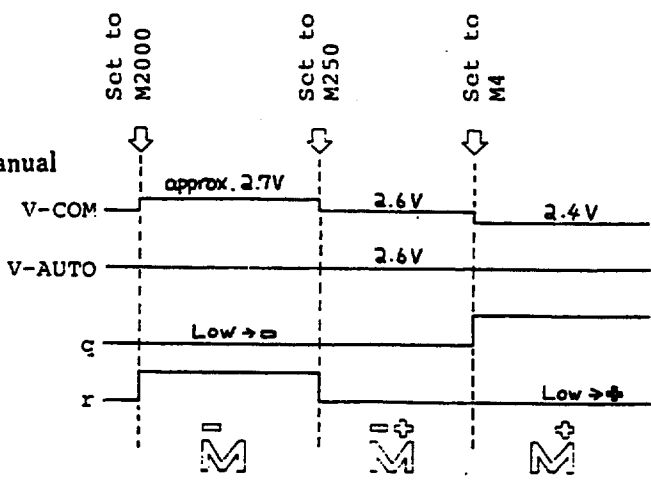

fig. 27 Circuit of exposure information display on Manual

fig. 28 Timing chart of exposure information display on Manual



4-3-7 Connection with Motor Drive

- 1) When MD is mounted, Power supply connector 40FA97-#17 pushes up MD switch #37 and cancels the power supply from the batteries installed in the camera. Thus MD is ready to supply Vccl to the circuit of camera.
- 2) Depressing the trigger button of MD half-way closes Power SW of MD to turn on the transistor for power supply. Next, through #37, MD allows Vccl of camera to go high to approx. 3 V. Simultaneously, the signal of power-ON is provided with the circuit of camera, and Vcc2 goes also high as Power SW of camera is closed.
- 3) When Vcc2 reaches Vccl, the signal of 16 sec.-holding is transferred back to MD. So MD will continue to supply Vccl to the camera.
- 4) Next, depressing the trigger button of MD all the way closes Release SW of MD. The signal goes through #1034 to drop the voltage of shutter release circuit of camera as Release SW is closed. Accordingly, Shutter is released.
- 5) After the closing curtain's travel completes, Closing curtain SW closes to provide MD with the signal of film-advancing through Closing curtain SW and Film-advance completion SW. Then, with a delay (ON-delay) of approx. 22 ms, MD starts to work for film-advancing. See Notice 11.
- 6) As soon as the film-advancing is started, Film-advance completion SW closes and then Closing curtain SW opens. Completing the film-advancing, Film-advance completion SW opens. Now the voltages of both the SWs go high to provide a signal for stopping the operation of MD. At this moment, the film-advance mechanism of camera also blocks MD mechanically, and Ending SW closes to stop MD electrically in approx. 15 ms before a delay (OFF-delay) of approx. 18 ms.
- 7) In case the continuous setting of MD is in use, MD provides a signal for shutter releasing in approx. 15 ms after Film-advance completion SW opens. It functions after this step in the same manner as above.

[Notice]

- 11 If depressing the shutter release button, opened Closing curtain SW will not allow MD to start film-advancing before the release button is freed.

table.7 Checking lands in exposure information on Manual

V-COM	-----	F-24	F-39	5-7	6-41	6-56
V-AUTO	-----	F-23	F-55	F-97		
q	-----	5-32				
r	-----	5-33				
COM-1/2000	-----	F-22	F-38	F-133		
COM-8s	-----	F-25	F-36	F-95		
Gray cord V	-----	F-31	F-46	6-62	5-14	
W	-----	F-30	F-50	6-61	5-9	
X	-----	F-29	F-48	6-60	5-11	
Y	-----	F-28	F-47	6-58	5-12	
Z	-----	F-27	F-49	6-57	5-8	

fig. 29 Circuit of connection with MD

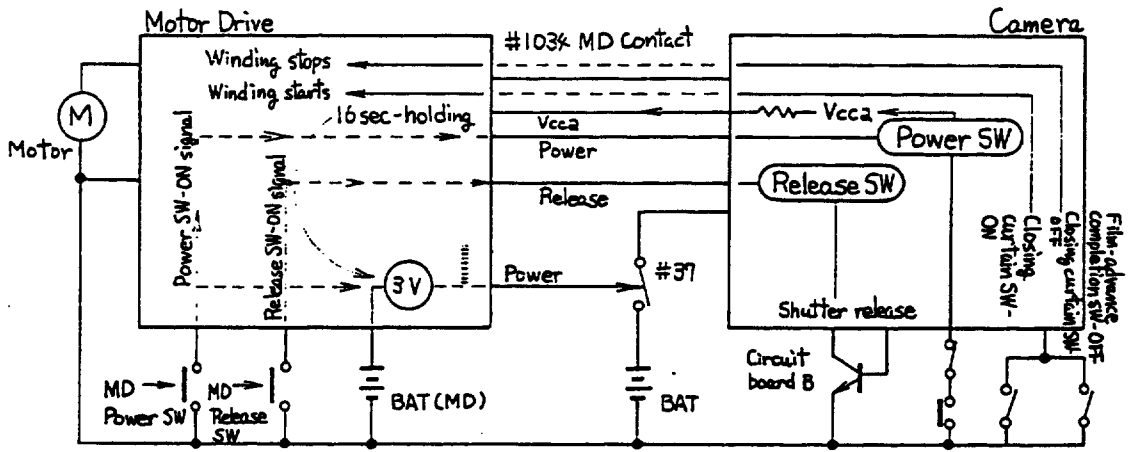
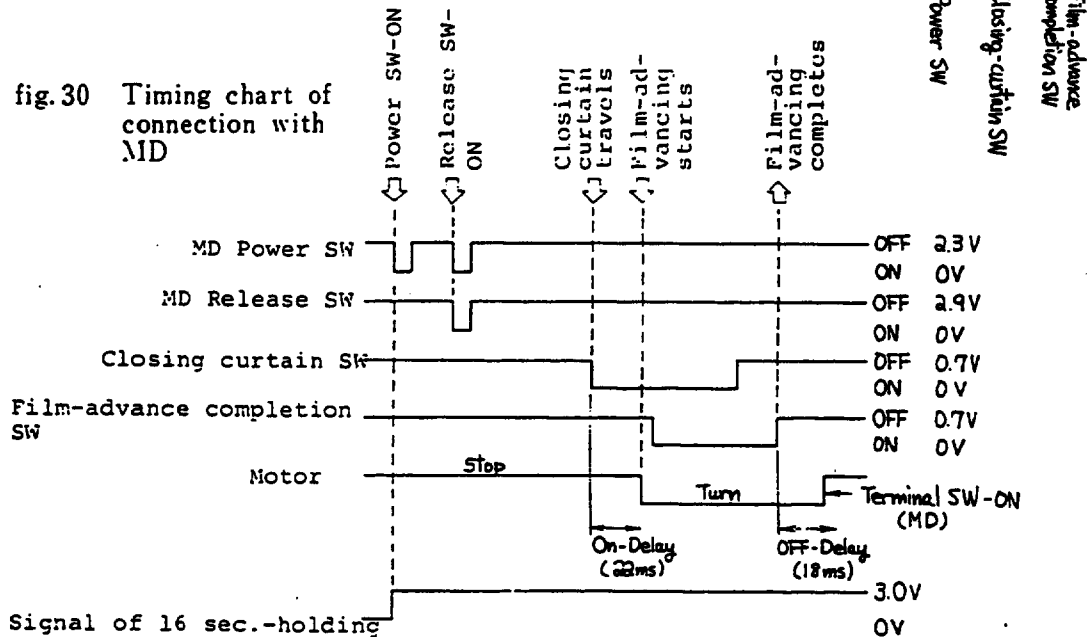

fig. 30 Timing chart of connection with MD



4-3-8 Self-timer

When Self-timer SW is closed, closed Shutter SW does not direct shut off Combination MG, and LED of self-timer starts blinking. For the first 8 seconds, it flashes 16 times with 2 Hz. But it blinks rapidly 16 times with \triangle 8Hz during the last 2 seconds. Totally for 10 seconds the LED continues to glow. And then Combination MG opens to release Shutter.

In case Self-timer SW is turned off during LED's glowing, LED stops to work at once and setting of Self-timer operation will be canceled.

4-3-9 Frame-counter

Replacing the camera back onto the body closes Counter SW until Frame counter advances to "START". It automatically controls the shutter speed delivery as below;

On Auto \longrightarrow 1/80 sec.
 On Manual settings faster than 1/60 sec. \longrightarrow 1/80 sec.
 On Manual settings slower than \triangle 1/125 sec. \longrightarrow same

When closing Counter SW, Terminal Ready-T goes high in the circuit.

4-3-10 Speed-light

Mounting the own speed-light unit as SB-12 allows the camera to control the shutter speeds in the same manner as Counter SW. Charging the speed-light supplies the current flow to the camera for lighting up of a ready light (LED) in the viewfinder. Light output control is automatically performed by the current flow from the circuit of camera, which is proportion to the light brightness.

4-3-11 Viewfinder Illuminator

Pressing the illuminator button makes a pressure onto Semiconductor #1028 to turn on FPC 3. And then Vcc2 is supplied to light up the illuminator.

fig. 31 MD connector's terminals

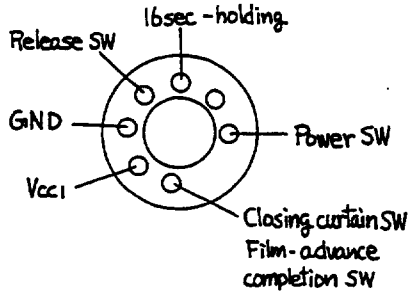

table 8 Checking lands in connection with MD

Vcc1	-----	F-2	F-15	F-61	F-122	6-50	6-110	
Power SW	-----	F-7	F-33	F-128	6-52			
Release SW	-----	F-6	F-32	F-125	6-10	6-51		
Closing curtain SW	---	F-4	F-34	F-62	F-129	6-65		
Film-advance completion SW		Signal of 16 sec.-holding					---	
							F-126 6-64	

fig. 32 Timing chart for self-timer operation

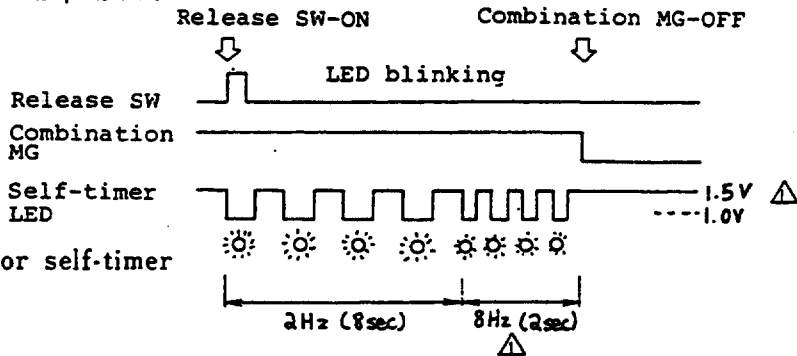

fig. 33 Circuit of frame-counter and speed-light control

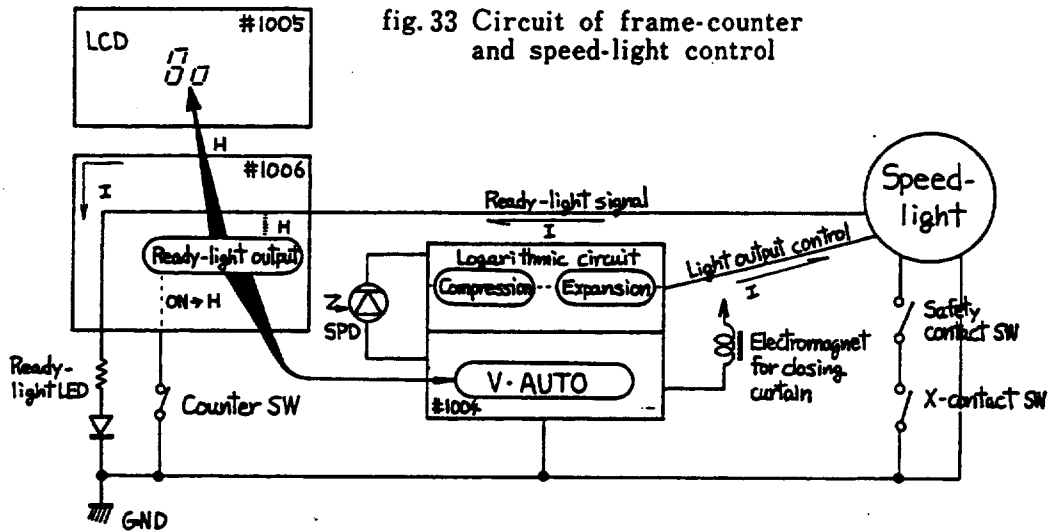

table.9 Checking lands à la carte

Ready-light terminal	-----	6-117	6-49	5-15
Counter SW	-----	F-5	F-52	6-66
Light-output control signal	-----	F-82	F-98	5-78
Self-timer LED	-----	F-16	F-35	6-108
Self-timer SW	-----	F-26	F-53	6-67
Ready-light LED	-----	6-44	5-10	5-77 5-74

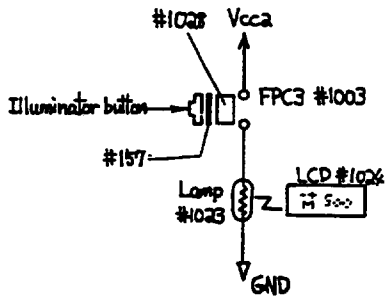
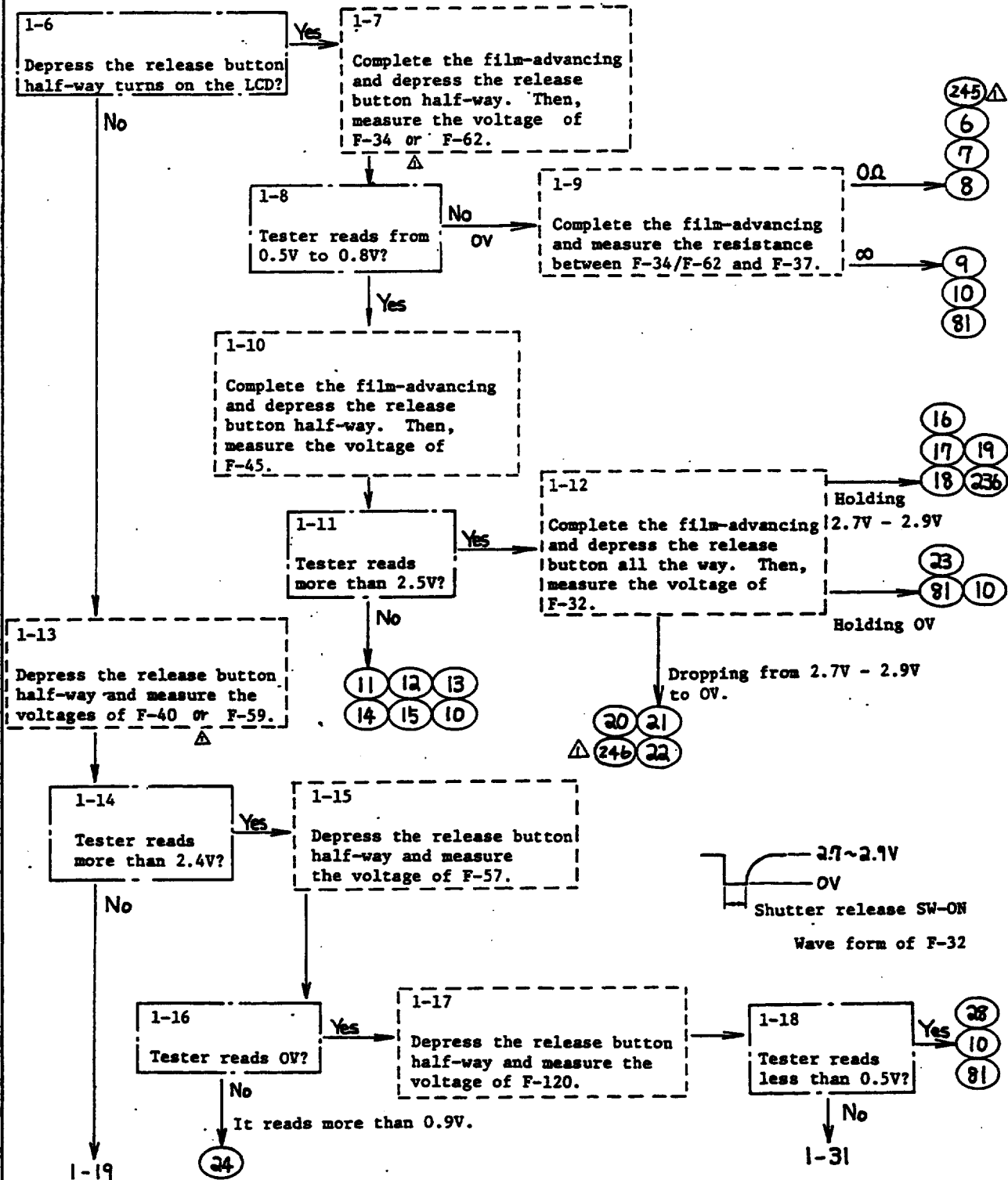

fig. 34 Illuminator for LCD

4-4 Troubleshooting Chart

4-4-1 Shutter fails to be released

- 1-0. Defects of the control circuit or those of other sections?
- 1-1. Batteries are OK? → Check batteries → (1)
- 1-2. Film-advancing is completed? → Stroke the film-advance lever → (2)
- 1-3. Power lock SW is turned on? → See the power lock SW knob → (3)
- 1-4. Self-timer is in use? → Depress the shutter release button to see the LED blinking → (4)
- 1-5. Extra-long time exposure in use? → Remove the lens to see the mirror locking up → (5)



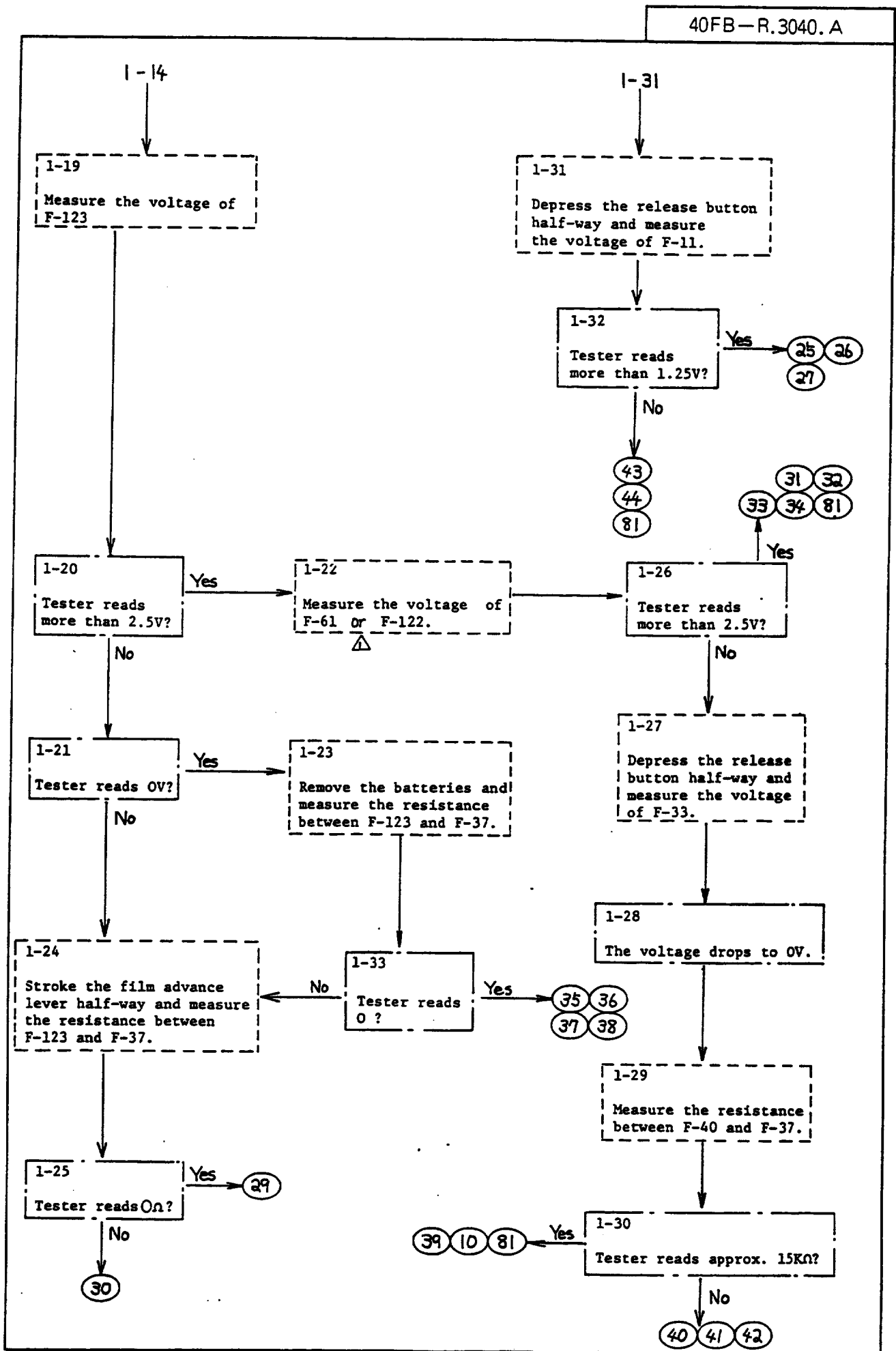

4-4-2 Shutter provides only the Time operation

2-0: Shutter provides only the Time operation on either Auto setting or Manual setting.

2-1
Shutter provides only the Time operation on both Auto and Manual settings?

Yes

2-2
Turn the shutter selector to Auto and depress the release button half-way. Then, measure the voltages of F-40 and F-50.

2-3
Tester reads 0V at both of them?

Yes

45 46
10 63

No 3V

2-4
On releasing the shutter, measure the wave form of F-60.

2-5
Tester reads 0.7V.

Yes

47 237

No 0V

2-6
Measure the voltage of the closing curtain MG.

Yes

72 10

2-7
Tester reads 3V?

No 0V

48 49

2-8
Trouble only on Auto setting?

Yes

△

2-9
Depress the release button half-way and measure V-AUTO (F-55).

No △

2-26

2-10
Tester reads from 2.2 to 2.8V?

2-11

2-18
On releasing the shutter, measure the wave form of V-AUTO (F-55).

2-19
The wave form of V-AUTO is straight?

Yes

64 65 27

No

2.0V

2-20
On releasing the shutter, measure the wave form of F-127.

2-21
The wave form goes low?

Yes

58 59

No

2-22
The wave form jumps?

Yes

61

No

60 62 10

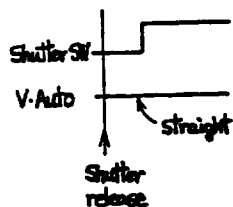
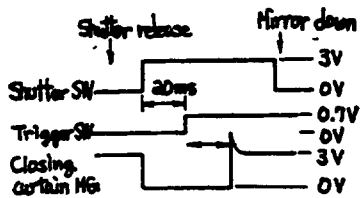

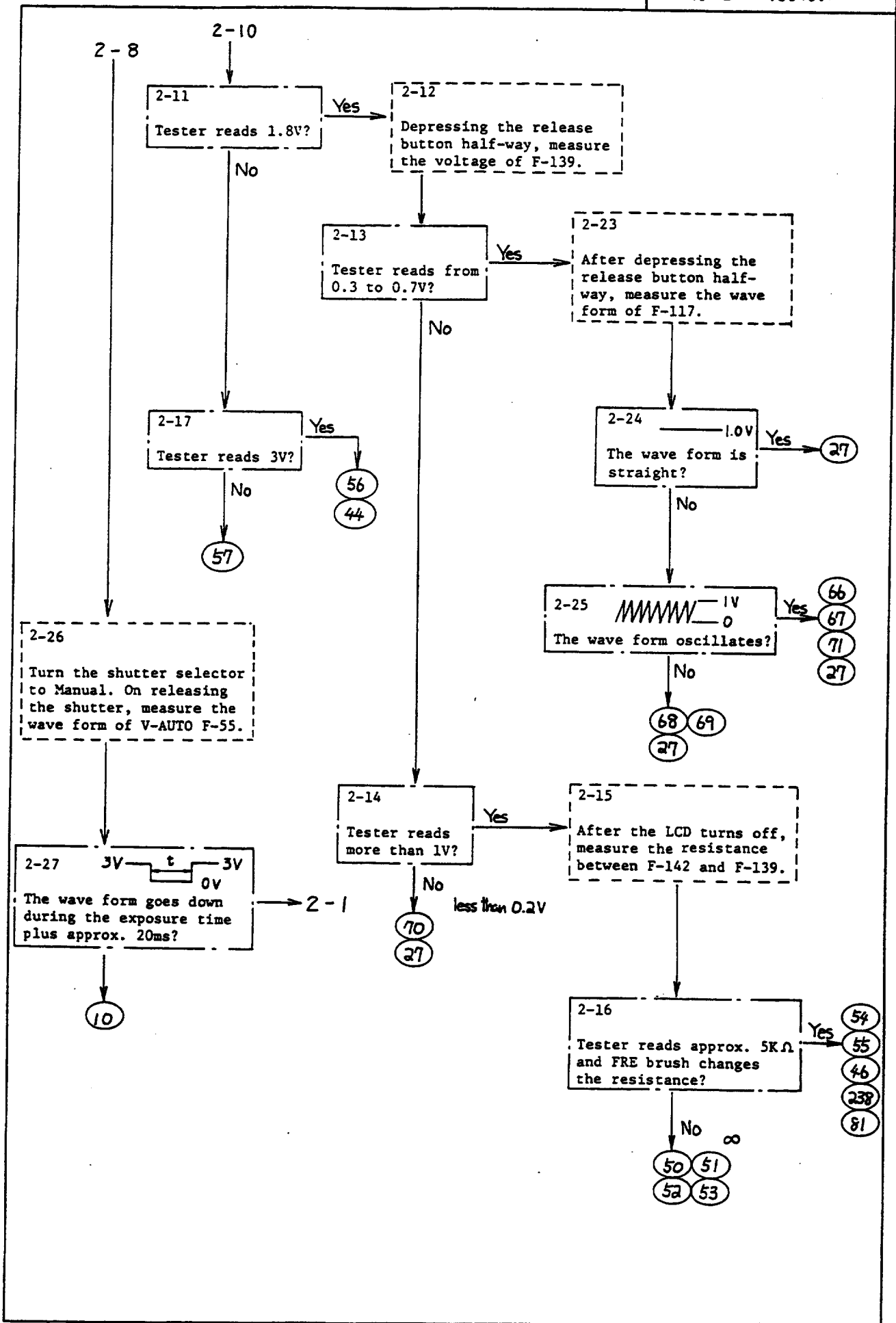

4-4-3 Shutter delivers only the speed of 1/2000 sec.

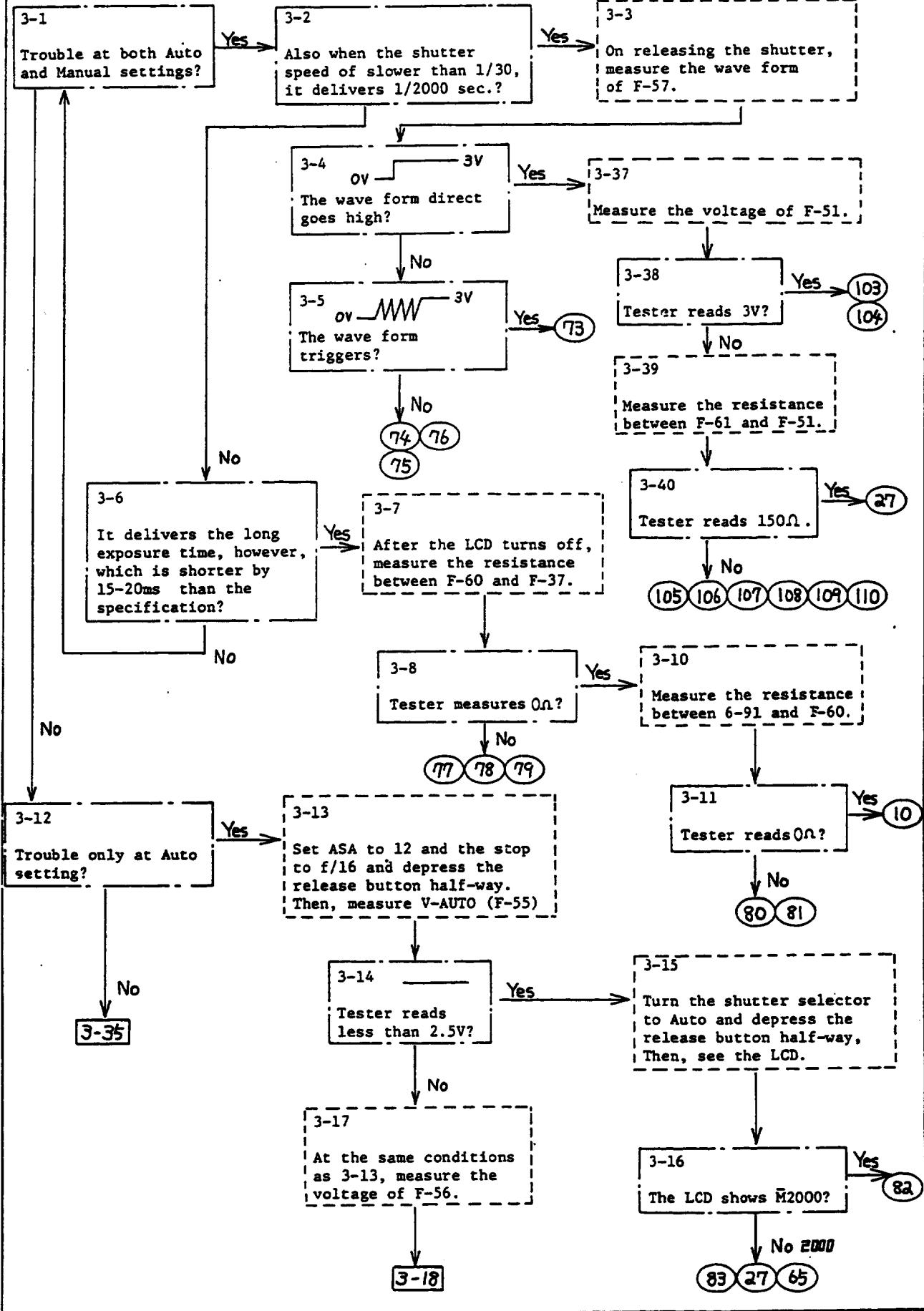

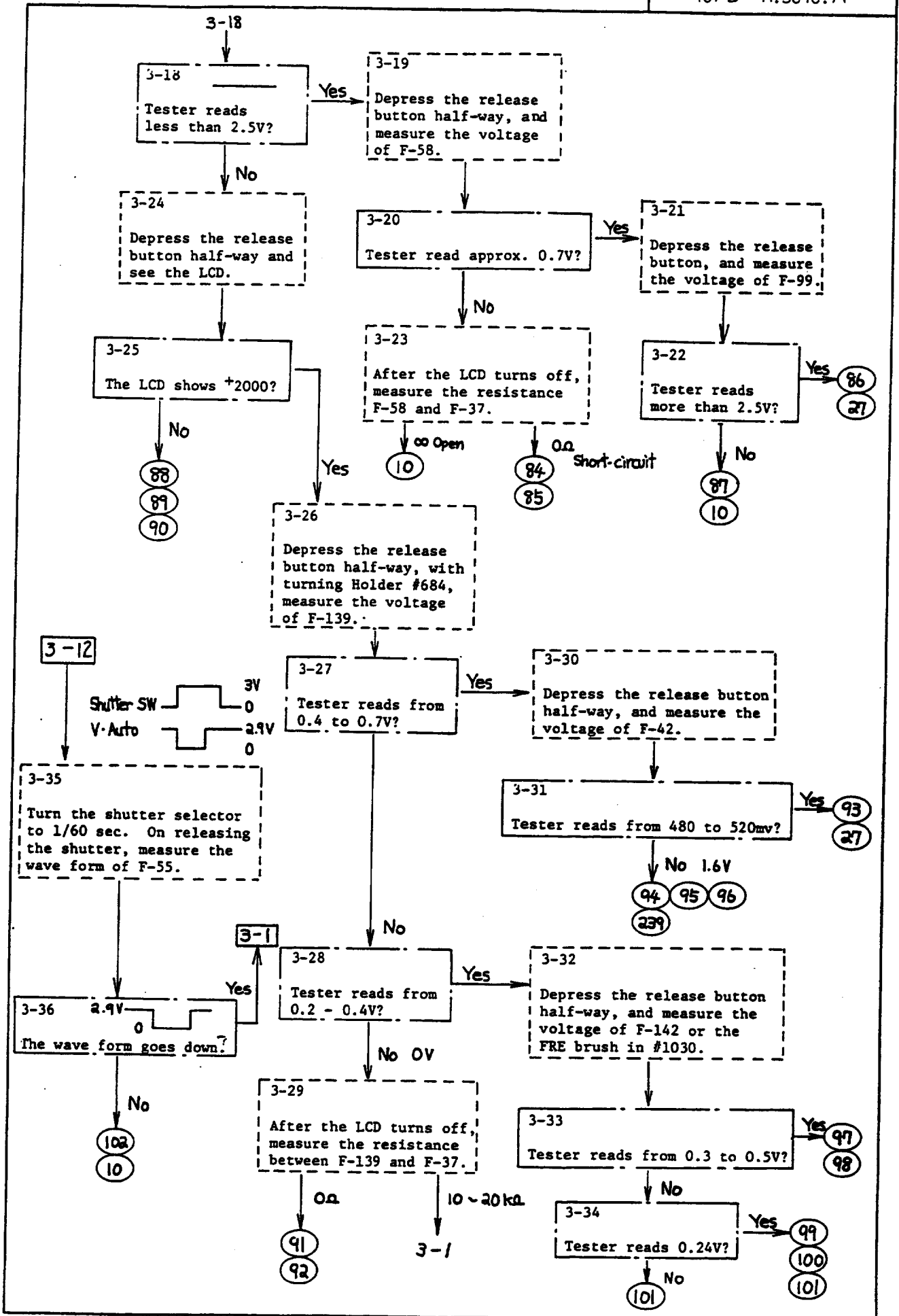

4-4-4 Shutter speed delivery is unstable on Auto.

- 4-1. The shutter speeds of slower than 1/50 sec. are sometimes delivered at 1/50 sec. → (61)
- 4-2. The shutter speeds of faster than 1/60 sec. deviate from specifications by from 3 to 5 ms. → (73) (111) (112) (113)
- 4-3. Under the low luminosity of less than LV4, the exposure time is shorter by more than approx. 1EV → (27)
- 4-4. The exposure time is longer or shorter by more than 1EV. → Make adjustments of each section in the following order;
- 1 B.C.OUT adjustment
 - 2 Delay-time adjustment
 - 3 Auto T adjustment
 - 4 FRE Y adjustment
 - 5 FRE shift adjustment
 - 6 LCD Y on AUTO adjustment
 - 7 LCD shift on AUTO adjustment
 - 8 LCD Y on Manual adjustment
 - 9 LCD shift on Manual adjustment
 - 10 Speed-light gain adjustment

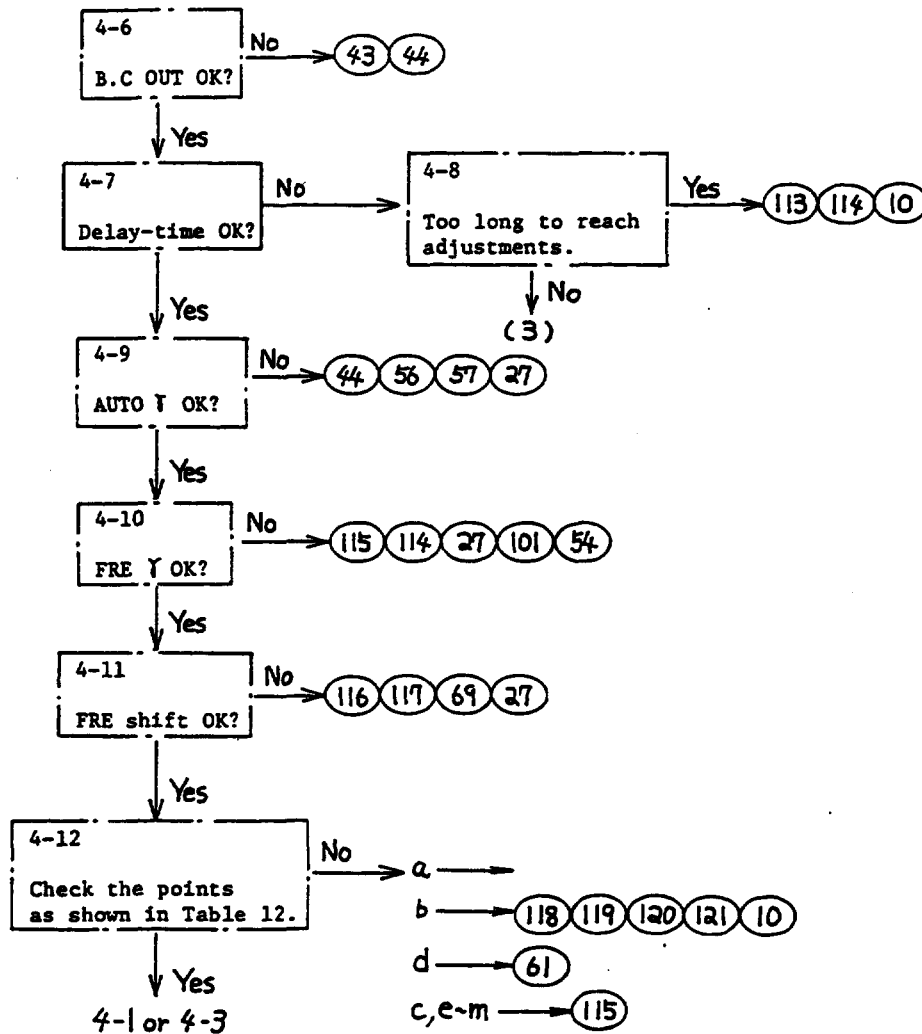

4-13. Under the low luminosity of less than LV4, the exposure time deviates from specification by approx. 0.5EV. → 122

Table 12 Check points after FRE shift adjustment is made.

Settings	Conditions	Shutter speeds
a. Self-timer ON	LV9·f/11	210 - 300ms
b. Self-timer OFF Memory lock ON	LV14·f/11	210 - 300ms
c. Memory lock OFF	LV14·f/11	6.2 - 9.8ms
d. Mirror locking-up		no deviations
e. —	ASA1600·LV9·f/2	0.4 - 0.6ms
f. —	ASA1600·LV9·f/4	1.6 - 2.5ms
g. —	ASA100·LV9·f/5.6	52 - 74ms
h. —	ASA25·LV9·f/8	420 - 600ms
i. —	ASA12 (Correction +1) LV9·f/11	3.2 sec. - 5.0 sec.
j. —	ASA100·LV4·f/2.8	420 - 600ms
k. —	ASA100·LV9·f/2.8	13 - 19ms
l. —	ASA100·LV14·f/2.8	0.4 - 0.6ms
m. —	ASA400·LV14·f/2	0.4 - 0.6ms

4-4-5 Shutter speed delivery is unstable on Auto and Manual.

5-1: The shutter speeds of faster than 1/60 sec. deviate from specifications by from 3 to 4 ms.

5-2
On releasing the shutter, measure the wave form of F-57.

5-5
The wave form goes direct high?

5-6
On releasing the shutter, measure the wave form of a grounding segment of Gray cords.
Ex. 1/125 Z

5-3
The wave form goes direct high?

5-4
On releasing the shutter, measure the wave form of F-60.

5-7
The wave form remains low.

No
Chattering
70

No
125
126
127

Yes
128
10

5-8
Shutter some times delivers the speed of 1/70 sec. (14.2ms) irrespective of settings.

5-9
On examining the LCD, release the shutter.

5-12
On releasing the shutter, measure the wave form of F-52.

5-10
The LCD shows 80?

5-13
The wave form remains high after the frame counter the first frame?

5-14
On releasing the shutter, measure the wave form of F-140.

5-11
The LCD fades 80?
Yes 10

No
129
130

5-15
The wave form remains low?
No
131
132

4-2 or 5-1

5-16
Shutter delivers 1/70 sec. (14.2ms) on Bulb and 1/2000 sec. (0.5ms) on Auto.

5-17
Turn the shutter selector to 2000, and measure the resistance between F-46 and GND.

5-18
Tester read 0Ω (short-circuit)?
Yes 136 10
No 133 134 135

5-19

The shutter speeds of lower than 1/8 sec. becomes faster.
(1/8 → 1/15, 1/4 → 1/30)

5-20

Turn the shutter selector to 8, and measure the resistance between F-50 and GND.

5-21

Tester reads 0Ω (short-circuit)?

Yes

(140) (10)

No

(137) (138) (139)

5-22

Shutter delivers 1/15 sec. on Auto and 2000, or on 1/30 sec. on 1000, 1/8 sec. on Bulb.

5-23

Turn the shutter selector to 2000, and measure the resistance between F-48 and GND.

5-24

Tester reads 0Ω (short-circuit)?

Yes

(144) (10)

No

(141) (142) (143)

5-28

Shutter delivers 1/1000 sec. on Auto and 2000, or 1/500 sec. on 250, 1/60 sec. on 1/125, 8 sec. on Bulb.

5-29

Turn the shutter selector to 2000, and measure the resistance between F-49 and GND.

5-30

Tester reads 0Ω (short-circuit)?

Yes

(152) (10)

No

(149) (150) (151)

5-25

Shutter delivers 1/250 sec. on Auto and 2000, or 1/500 sec. on 1000, 2 sec. on Bulb.

5-26

Turn the shutter selector to 2000, and measure the resistance between F-47 and GND.

5-27

Tester reads 0Ω (short-circuit)?

Yes

(148) (10)

No

(145) (146) (147)

5-31
Shutter delivers Bulb on 2000, 8 sec. on 1000 or 4 sec. on 500.

5-32
Turn the shutter selector to 2000, and measure the resistance between F-50 and GND.

5-33
Tester reads 0Ω (short-circuit)?

No
(2) 50~100kΩ

5-34
Turn the shutter selector to 1, and release the shutter to check the speed.

5-35
Shutter delivers the proper speed on 1?

Yes → (153) (154) 5-42
No 8ms → (155) (156) (10)

5-36
Shutter delivers 1/1000 sec. on 500, 1/2000 sec. on 250, 1/1000 sec. on 30 or 1/2000 sec. on 15.

5-37
Turn the shutter selector to 500, and measure the resistance between F-47 and GND.

5-38
Tester reads 0Ω (short-circuit)?

No
(3) 50~100kΩ

Yes → (157) (160) (161)

5-39
Shutter delivers 1/2000 sec. on 1000, 1/2000 sec. on 250, 1/15 sec. on 125.

5-40
Turn the shutter selector to 1000, and measure the resistance between F-49 and GND.

5-41
Tester reads 0Ω (short-circuit)?

No
(3)

Yes → (158) (159)

5-42
Shutter delivers Bulb on 2000, 2 sec. on 250, 1 sec. on 125.

5-43
Turn the shutter selector to 2000, and measure the resistance between F-50 and GND.

5-44
Tester reads 0Ω (short-circuit)?

No
(2) 50~100kΩ

5-45
Turn the shutter selector to 500, and release the shutter to check the speed.

5-46
Shutter delivers the proper speed on 500?

Yes → (162) (163)
No 4s → 5-31

4-4-6 LCD will not change +2000.

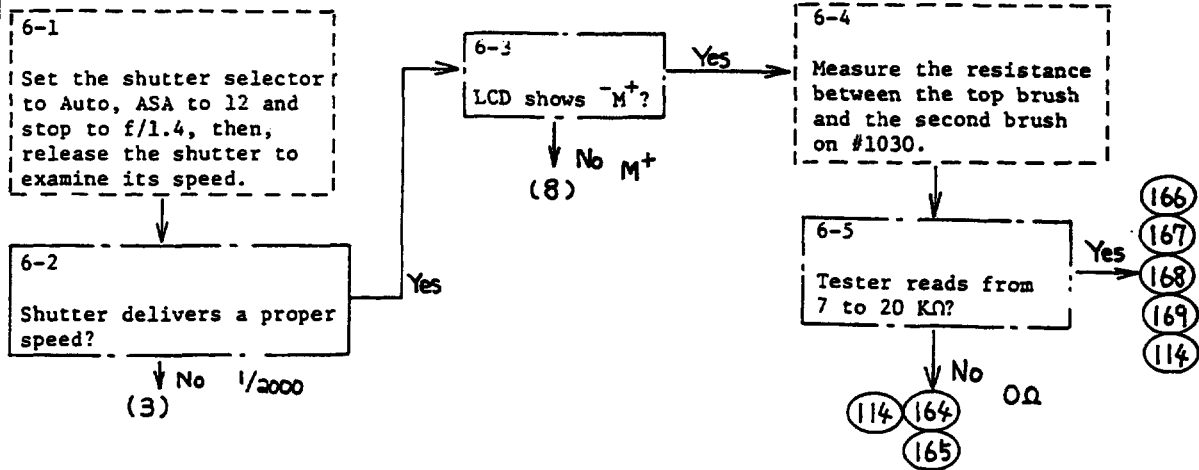

4-4-7 LCD will not change - 8.-

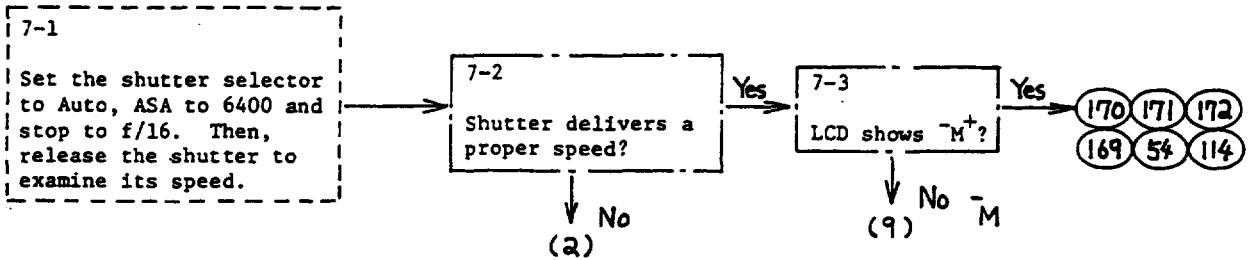

4-4-8 LCD will not change M+

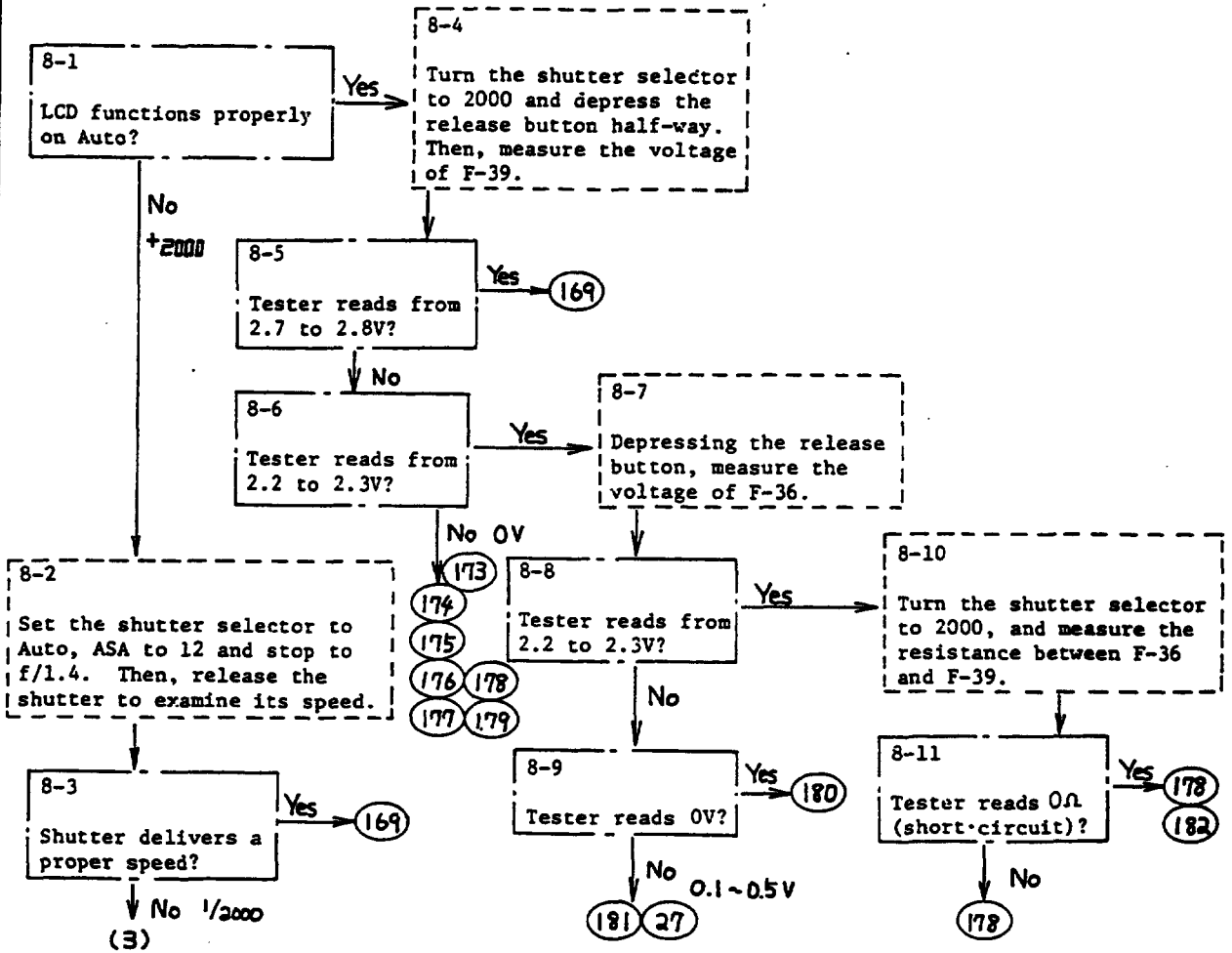

4-4-9 LCD will not change -M.

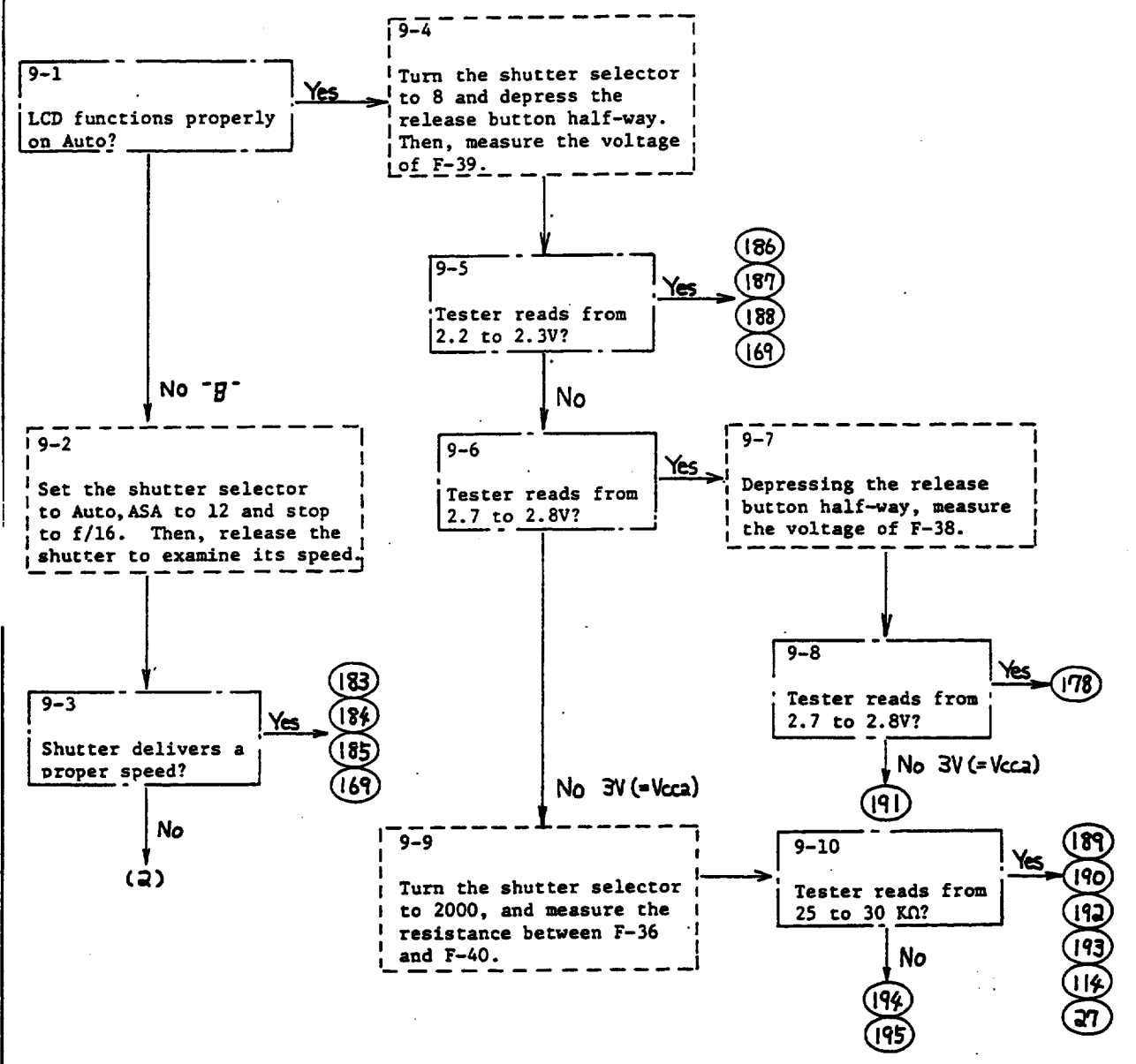

4-4-10 Troubles of LCD

10-1
LCD will not turn on.

10-2
Shutter will be released?

(1)

10-3
Depress the release button and measure the voltage of soldering of #1080.

10-4
Tester reads 3V?

Yes (169) (198)

No (199) (200) (201) (169) (240)

10-5
LCD will not turn off during the exposure.

10-6
Turn the shutter selector to 1, and release the shutter to examine its speed.

10-7
Shutter delivers 1 sec.?

No (74)

10-8
LCD functions properly on Auto?

Yes (196) (197)

No (207) (208)

10-9
All the LCD segments will turn on improperly.

10-10
Depressing the release button, measure the wave form of BP.

10-11
The wave form triggers frequently?

No (202)

Yes (203) (204) (205)

10-12
One of the LCD segments is fading.

10-13
Depressing the release button, measure the wave form of the faded segment.

10-14
The wave form triggers frequently?

No (206)

Yes (203) (204) (205)

10-15
LCD shows \bar{M}^+ also on Auto. → (207) (208)

10-16
LCD shows \bar{M}^- on X. → (207) (208)

10-17
2000 looks like 2800. → (209) (210)

10-18
LCD shows \bar{M}^+ 2800 on Auto. → (211) (212)

10-19
Lightening the illuminator changes the LCD to higher speed by 1EV. → (213)

10-20
LCD will not turn off.

10-21
Measure the resistance
between F-33 and F-37.

10-22
Tester reads 0Ω
(short-circuit)?
Yes → (242) (243)
No → (241) (10)

10-23
Mark of \bar{M}^+ will not turn off with the change of more than 0.5EV. → (244) (169)

4-4-11 Troubles of Self-timer

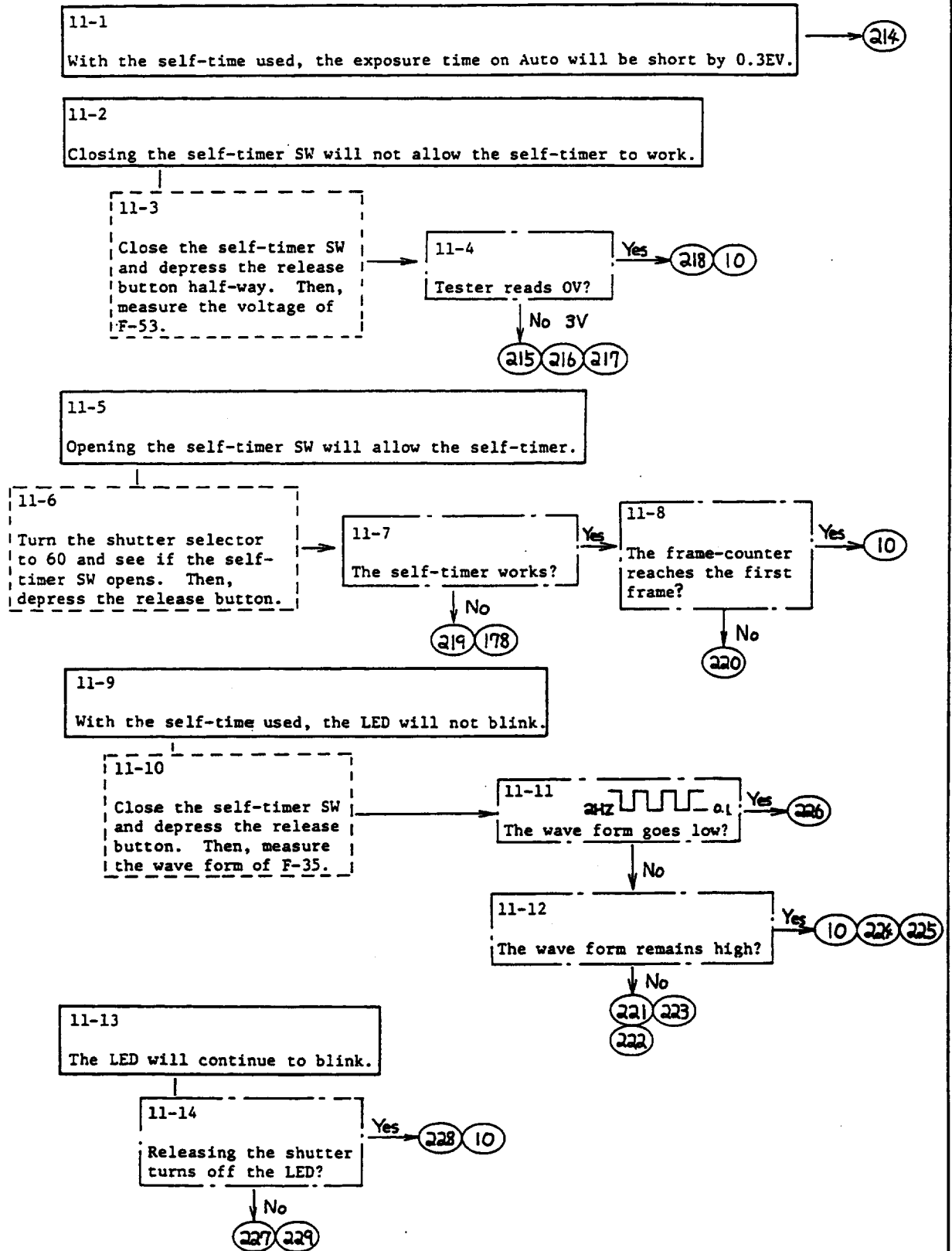

4-4-12 Troubles of speed-light

- 12-1. The ready-light LED will continue to blink.
 12-2. The speed-light doubles its flash in longer exposure time.
 12-3. The ready-light LED will not turn on.

4-5 Causes

1. Batteries are dead.
2. Film-advancing is not completed.
3. Power lock SW opens.
4. Self-timer SW closes.
5. Exposure is in operation.
- ! 6. Clearance between contacts of Film-advance completion SW is not enough for opening after the film-advancing is completed.
7. Closing curtain SW remains closed.
8. Soldering bridge over F-4 and F-3 on #312 of #1001.
See Figure 31.
9. Separation of 6-65 at the solder joint between #1001 and #1006.
10. Defective #1006.
- ! 11. Breakage of land of Combination magnet on #1001. See Figure 30.
12. Poor solder joint of #1046 (F-63 and F-64)
13. Reversely installed #1046. Change its polarities (F-13 is positive).

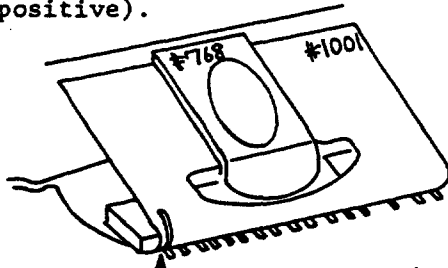
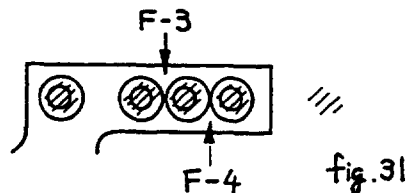

fig. 30 Land of Combination magnet



14. Defective #1046
15. Film-advance completion SW remains opened.
16. Breakage or poor solder joint of #1084 (F-6)
17. Breakage or poor solder joint of #1085
18. Poor contact of Power lock SW
19. Poor contact between #333 and #244
20. Incorrect wiring between #199 and #1001. Use black lead wire for F-17 and red one for F-18.
21. Defective #199
22. Defective assembly unit of #199. Shutter clicks, but not to be released.
23. Separation of 6-51 at the solder joint between #1001 and #1006.
24. Shutter SW remains closed.
25. Short-circuit between the foot of #1096 and the pin of #1004 (F-105) due to the breakage of #1097.

26. Poor solder joint of pin of BC-OUT (F-106) on #1004.
27. Defective #1004
28. Separation of land of BC-OUT (6-80) at the solder joint between #1001 and #1006.
29. Short-circuit between land of BAT and that of Film-advance completion SW at the solder joint of #1034 with #1001.
30. Batteries are dead.
- !! 31. Breakage of #37
32. Poor contact between #37 and #1034
33. Poor solder joint of #37 with #1001 (F-122)
34. Poor solder joint of land of BAT between #1001 and #1034
35. Breakage of #1061. It causes short-circuit with the body die-casting.
- ! 36. Solder joint (F-122) between #37 and #1001 short-circuits with #200.
37. F-2 short-circuits with F-3 at the solder joint between #1001 and #312. See Figure
38. Black lead wire from Closing curtain electromagnet short-circuits with a mechanical part.
39. Separation of 6-52 at the solder joint between #1001 and #1006.
40. F-92 short-circuits with F-91 at the solder joint between #1001 and #1004.
41. 6-68 short-circuits with 6-69 at the solder joint between #1001 and #1006.
42. F-92 short-circuits with F-91 at the solder joint of #1089 with #1003.
- ! 43. Poor solder joint of #1009 (F-8 and F-11)
44. Defective #1009
45. Short-circuit between Gray cords (from F-22 to F-31)
46. Circuit-pattern of #1006 short-circuits with the body die-casting.
47. Trigger SW remains closed.
48. Black lead wire from Closing curtain electromagnet short-circuits with a mechanical part.
49. The foot negative of #1059 short-circuits with a mechanical part.
- !! 50. Breakage of #1078
51. Floating of #701
52. Floating of #702 and #703

53. Floating of #706
54. Poor solder joint of #1030
55. Separation of 6-81 at the solder joint between #1001 and #1006.
- ! 56. Poor solder joint of #1009 (F-9 and F-10)
57. Poor solder joint of #1009 (F-8)
58. Poor solder joint of #1048 (F-69 and F-70)
59. Defective #1048
60. F-126 short-circuits with F-127 at the solder joint between #1034 and #1001.
- !! 61. Insufficient contact pressure of Shutter SW causes chattering due to the firing of opening curtain.
62. F-99 short-circuits with the next land on #1004.
63. #245 is not being hooked to #231.
64. F-103 short-circuits with on #1004.
65. Defective #1049
66. Poor solder joint of #1050 on #1090.
67. Breakage of #1074 on #1090.
68. Poor solder joint of #1019 or reversely installed #1019 on #1004. Change its polarities (Cathode is placed to F-114).
69. Poor solder joint of #1029 or defective #1029 on #1004.
70. Poor solder joint of F-102 on #1004.
71. Poor solder joint of #1053 on #1006. Notice that the trouble of Time-operation causes when the voltage of batteries drops. (6-85 and 6-86)
72. Land 6-5 short-circuits with 6-6 at the solder joint of #1037 on #1006.
- ! 73. Insufficient contact pressure of Shutter SW
74. Defective Shutter SW. Notice that the switch remains defectively opened when Mirror rising to the taking position.
75. Breakage or poor solder joint of #1081
76. Breakage or poor solder joint of #1082
77. Defective Trigger SW. Notice that the switch remains defectively opened
78. Poor solder joint of F-3 at the connection between #312 and #1001.
79. Breakage or poor solder joint of #1068.
80. Separation of 6-53 at the solder joint between #1006 and #1001.
81. Breakage of printed circuit of #1001.
82. Short-circuit between 6-47 and 6-48 on #1006, or between 5-13 and 5-14 on #1005

83. Poor solder joint of #1037 on #1006 (6-5 and 6-6)
84. Memory SW remains closed.
85. Short-circuit between 6-70 and 6-69 at the solder joint on #1006.
86. Poor solder joint of F-99 on #1001.
87. Separation of 6-70 on #1006.
88. Solder joint of #687 is excessively large, and comes in contact with the top cover.
89. Breakage of #1078 (It short-circuits with the top cover)
90. Solder joint of #1078 on #706 short-circuits with the top cover.
- ! 91. Defective solder joint of #1078 short-circuits with #661.
92. #706 or #687 short-circuits with the camera body
93. Incorrect wiring between #1090 and #1004.
 - #1089 → F-92
 - #1087 → F-101
 - #1088 → F-117
 - #1062 → F-106
94. F-89 short-circuits with F-90 at the solder joints between #1001 and #1004.
- ! 95. Defective #1009 (F-10)
96. F-12 short-circuits with F-13 on #1009.
97. F-139 short-circuits with F-142.
98. Caulked section of #701 and #702 on #688 short-circuits with the solder joint of #687 with #1027.
99. F-134 short-circuits with F-135 at the solder joint of #1030 to #1006.
100. F-134 short-circuits with F-135 on #1030.
101. Brush of #1030 defectively contacts with the front body.
102. Separation of 6-76 at the solder joint of #1001 with #1006.
103. Legs positive and negative of #1059 short-circuit each other at the solder joint of #383.
104. Black lead-wires of #317 short-circuit each other at the solder joint of #383.
- !! 105. Poor solder joint of F-1 on #1001.
- !! 106. Poor solder joint of F-2 on #1001.
- ! 107. Breakage of black lead-wire of #317
108. Although the film-advance is completed, the insufficient amount of charging #292 will not bring #316 in contact with #317.
109. Poor contact of #316 or #317.

110. Poor solder joint of F-96 on #1004.
111. Poor solder joint of #1060 (F-76 and F-77)
112. Poor solder joint of #1071 (F-79 and F-83)
113. Poor solder joint of F-138 on #1030.
114. Defective #1030.
115. Defective #1027.
116. 6-77 short-circuits with 6-76 at the solder joints of #1006 with #1001
117. 6-38 short-circuits with 6-39 or 6-39 short-circuits with 6-40 at the solder joints of #1006 with #1002.
- ! 118. Memory SW remains opened or fails to close sufficiently.
119. Breakage or poor solder joint of #1083.
120. Poor contact between #764 and #6 in the assembly unit of Memory SW.
121. Separation of 6-70 at the solder joints of #1006 to #1001.
122. Poor contact between #1099 and #1 under #1005.
123. Clearance of contact blades of Trigger SW is too narrow to open.
124. #1068 short-circuits with the ground, because the body catches #1068 and damages its vinyl cover.
- !! 125. When installing #201 onto the camera body, #201A fails to be used. Thus, the mechanical operation shocks #224 to float.
126. Deform of #224.
127. Contact pressure of #224 onto #1008 is insufficient.
128. Contact pressure of the brush for Delay-time adjustment section on #1030.
129. Breakage of #1067. It short-circuits with the body.
130. Deform of #421. It short-circuits with the body.
131. 6-44 short-circuits with 6-43 or 6-55 at the solder joint of #1006 with #1002.
132. 5-10 short-circuits with 5-9 or 5-11 at the solder joint of #1005 with #1002.
133. Breakage of Gray-cord V on #1032, which connects to #1032.
134. Poor solder joint of #1032 with #222.
135. Separation of #224 on #1008 (Section V)
136. Separation of 6-62 at the solder joint of #1006 with #1001.
137. Breakage of Gray cord W, which connects to F-30 on #1032.
138. Poor solder joint between #222 and #1032. (Section W)
139. Separation of #224 on #1008. (Section W)

140. Separation of 6-61 at the solder joint of #1006 with #1001.
141. Breakage of Gray cord X, which connects to F-29 on #1032.
142. Poor solder joint between #222 and #1032 (Section X)
143. Separation of #224 on #1008 (Section X)
144. Separation of 6-60 at the solder joint of #1006 with #1001.
145. Breakage of Gray cord Y, which connects to F-28 on #1032.
146. Poor solder joint between #222 and #1032 (Section Y)
147. Separation of #224 on #1008 (Section Y)
148. Separation of 6-58 at the solder joint of #1006 with #1001.
149. Breakage of Gray cord Z, which connects to F-27 on #1032.
150. Poor solder joint between #222 and #1032 (Section Z)
151. Separation of #224 on #1008 (Section Z)
152. Separation of 6-57 at the solder joint of #1006 with #1001.
153. Short-circuit between Gray cords V and W at the solder joint of #222 with #1032.
154. Short-circuit between 6-62 and 6-61 at the solder joint of #1006 with #1001.
155. Short-circuit between Gray cords W and X at the solder joint of #222 with #1032.
156. Short-circuit between 6-61 and 6-60 at the solder joint of #1006 with #1001.
157. Short-circuit between Gray cords X and Y at the solder joint of #222 with #1032.
158. Short-circuit between Gray cords Y and Z at the solder joint of #222 with #1032.
159. Short-circuit between 6-58 and 6-57 at the solder joint of #1006 with #1001.
160. Short-circuit between 6-45 and 6-46 at the solder joint of #1006 with #1002.
161. Short-circuit between 5-11 and 5-12 at the solder joint of #1005 with #1002.
162. Short-circuit between 6-43 and 6-42 at the solder joint of #1006 with #1002.
163. Short-circuit between 5-9 and 5-8 at the solder joint of #1005 with #1002.
164. Short-circuit between 6-36 and 6-37 at the solder joint of #1006 with #1002.
165. Short-circuit between 5-2 and 5-3 at the solder joint of #1005 with #1002.

166. Short-circuit between 6-37 and 6-38 at the solder joint of #1006 with #1002.
167. Short-circuit between 5-3 and 5-4 at the solder joint of #1005 with #1002.
168. Short-circuit between 6-23 and 6-24 at the solder joint of #1006 with #1030.
169. Defective #1005
170. Separation of 6-36 or 6-37 at the solder joint of #1006 with #1002.
171. Separation of 5-2 or 5-3 at the solder joint of #1005 with #1002.
172. Poor solder joint of #1042 on #1005 (5-72 and 5-73)
173. Poor solder joint between 1/2000-section of #221 and #1032 or breakage of circuit pattern on #1032.
174. Breakage of 1/2000-section, which connects to F-22 on #1032.
175. Separation of #217 on #1007
176. Poor solder joint between COM-section of #221 and #1032 or breakage of circuit pattern on #1032.
177. Breakage of COM-section, which connects to F-24 on #1032.
178. Defective #1007
179. Short-circuit between #201 and 1/2000-section of #221 or its solder joint.
180. 8 sec.-section of #221 defectively contacts with #852.
181. Short-circuit between 6-29 and 6-28 at the solder joint of #1006 with #1030.
182. Short-circuit between 8 sec.-land and COM-land at the solder joint of #221 with #1032.
183. Separation of 6-27 at the solder joint of #1006 with #1001.
184. Separation of 6-34 at the solder joint of #1006 with #1001.
185. Separation of 5-19 at the solder joint of #1005 with #1002.
186. Separation of 6-56 at the solder joint of #1006 with #1001.
187. Separation of 6-41 at the solder joint of #1006 with #1002.
188. Separation of 5-7 at the solder joint of #1005 with #1002.
- !! 189. Separation of 6-82 at the solder joint of #1006 with #1001.
190. Poor solder joint of 6-29 at the solder joint between #1006 and #1030.
191. Short-circuit between 6-24 and 6-25 due to breakage of cover of #1096 at the solder joint of #1006 with #1030.
192. Poor solder joint of F-95 at the solder joint between #1004 and #1001.

193. Short-circuit between F-95 and F-96 at the solder joint of #1001 with #1004.
194. Poor solder joint between 8 sec.-section of #221 and #1032 or breakage of circuit pattern of #1032.
195. Breakage of 8 sec.-section, which connects to F-25 on #1032.
196. Separation of 6-47 at the solder joint of #1006 with #1002.
197. Separation of 5-13 at the solder joint of #1005 with #1002.
198. Poor solder joint of #1043 on #1005 (5-68 and 5-69)
199. Breakage of #1080, which causes the short-circuit with the body die-casting.
200. Short-circuit between 5-35 and 5-36 at the back of #1005.
201. Short-circuit between 5-70 and 5-71 at the back of #1005.
- ! 202. Separation of 5-61 at the solder joint of #1005 with #1003.
- ! 203. Poor contact between #1028 and #1024.
204. Defective #1003
205. Defective #1024
- ! 206. Separation of a partial segment at the solder joint of #1005 with #1003. For example, separation of 5-54.
207. Short-circuit between 6-48 and 6-47 at the solder joint of #1006 with #1002.
208. Short-circuit between 5-4 and 5-13 at the solder joint of #1005 with #1002.
209. Separation of 6-49 at the solder joint of #1006 with #1002.
- ! 210. Separation of 5-15 at the solder joint of #1005 with #1002.
211. Short-circuit between 6-48 and 6-49 at the solder joint of #1006 with #1002.
212. Short-circuit between 5-14 and 5-15 at the solder joint of #1005 with #1002.
213. Poor solder joint of Vcc-land on #1003 with #1089
214. Poor solder joint of #1006A (6-7)
215. Poor solder joint of #221 with #1032
216. Breakage of Self-timer SW section on #1032.
217. Poor contact between #216 and #1008
218. Separation of 6-67 at the solder joint of #1006 with #1001.
219. Short-circuit between Self-timer SW section and Gray cord Z at the solder joint of #221 with #1032.
220. Short-circuit between 6-67 and 6-68 at the solder joint of #1006 to #1001.

221. Poor solder joint or breakage of #1065 or #1066
222. #1065 and #1066 are improperly connected to #1021
(its polarities reversely installed)
223. #1065 and #1066 are improperly connected to #1001
(its polarities reversely installed)
#1065 \Rightarrow F-16 #1066 \rightarrow F-15
224. Poor solder joint of #1038 on #1006 (6-83 and 6-84)
225. Separation of 6-54 at the solder joint of #1006 with #1001.
226. Defective #1021.
227. Breakage of #1065, which causes short-circuit with the body die-casting.
228. Short-circuit between 6-54 and 6-53 at the solder joint of #1006 with #1001.
229. Short-circuit between #1038 (6-83-6-84) and #1054 (6-14-6-15) on #1006.
230. Short-circuit between Vcc2-land and LED-land at the solder joint of #1003 with #1089.
231. Safety contact SW chatters when opening.
232. Separation of 5-38 at the solder joint of #1005 with #1003.
233. Short-circuit between 5-38 and 5-39 at the solder joint of #1005 with #1003.
234. Poor solder joint or reversely installed polarities of #1020 with #1003.
235. Poor solder joint or breakage of #1074 (5-77)
236. Defective #1092
237. Short-circuit between #246 and the body die-casting.
238. Defective #1002
239. Short-circuit between the circuit pattern of #1090 and the body die-casting.
240. Breakage of #1080, which causes short-circuit with the body die-casting.
241. Poor solder joint or improperly installed #1058 on #1006.
242. Short-circuit between #328 and the body die-casting.
243. Short-circuit between #382, #383 or #1063 and the body die-casting.
244. Poor solder joint of #1096 at the back of #1006.
- △245. Short-circuit of #1070 with the body die-casting.
- △246. Breakage of the red and black lead wires from the shutter release magnet.

Section 5 Inspection Standard for Repair



Inspection Standard for Repair

Item	Condition/Standard			Remarks		
Shutter Speed	Exposure time	Setting or theoretical shutter speed	Tolerance limits (ms)		Shutter tester (J19022-1) When measuring, note the following: 1) Be sure to close the eye-piece shutter. 2) At low-light level side, prevent the surrounding light from affecting the measured value.	
			standard	Auto		Manual
		2000	0.488	Δ 0.31 - 0.77		Δ 0.33 - 0.73
		1000	0.977	0.62 - 1.54		Δ 0.68 - 1.41
		500	1.95	1.38 - 2.76		1.43 - 2.66
		250	3.91	2.76 - 5.53		3.91 - 5.34
		125	7.81	5.53 - 11.0		5.72 - 10.7
		60	15.6	11.0 - 22.1		12.7 - 19.2
		30	31.2	22.1 - 44.3		25.3 - 38.4
		15	62.5	44.2 - 88.4		50.8 - 76.9
		8	125	88.4 - 177		102 - 153
		4	250	174 - 354		203 - 308
		2	500	354 - 707		406 - 616
		1	1000	707 - 1414		812 - 1231
		2	2000	1414 - 2828		1620 - 2460
4	4000	2549 - 6277	3250 - 4920			
8	8000	5098 - 12553	6500 - 9850			
X	14.2		13.5 - 17.5			
Automatic Shutter Speed	Memory lock	Setting LV9, ASA100 and F5.6, measure the automatic shutter speed and designate it as "To". Next, depressing the memory lock button, change the LV only, then measure the shutter speed after 30 sec. and designate it as "Tm". In this case, the following formula should be established: $\left \log_2 \frac{T_m}{T_o} \right \leq 0.2$			Shutter tester (J19022 - 1)	
	Auto limiter	Automatic shutter speed to be Δ 0.25 - 0.73ms under the following conditions (regardless of F/No. changes). ① LV14, ASA400, F4 ② LV14, ASA400, F2.8 ③ LV14, ASA400, F2			Shutter tester (J19022 - 1)	

	Item	Condition/Standard	Remarks
	Auto flash Synchronization	Synch speed at "Auto" setting when strobe power is ON: 13.7 - 18.1ms (Liquid crystal display "80")	Shutter tester (J19022 - 1) Dummy strobe (J18077)
	Unevenness of exposure	Exposure balance between the middle of the frame and the both frame edges: Δ 1/2000 sec. = $\pm 0.15ms$ Δ 1/1000 sec. = $\pm 0.2ms$ Δ 1/1000 sec. - 8 sec. = $\pm 0.2EV$	Shutter tester
	Bounce	Shutter curtain bounce should not be detected at every shutter speed setting.	Bounce inspection tool
Manual Shutter Speed	Time of shutter curtain travel across the aperture	10.0 \pm 0.5ms	Shutter tester
	Manual flash Synchronization	Synch speed at Manual settings when strobe power is ON. Shutter speeds of X or faster: 1/80 Shutter speeds slower than X: Set shutter speed	Dummy strobe (J18077) Shutter tester
	Mechanical shutter-release	Set the shutter-speed dial to any one of 1/2000 to 1/125, then release the shutter via mechanical shutter-release knob. Shutter speed: 1/55 sec.: 13.7 - 26.9ms	Shutter tester

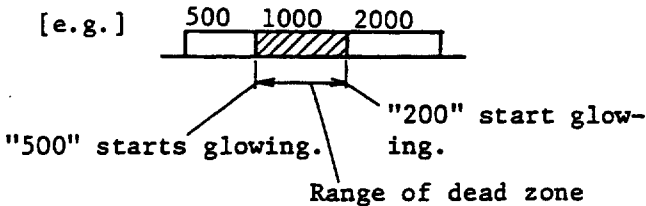
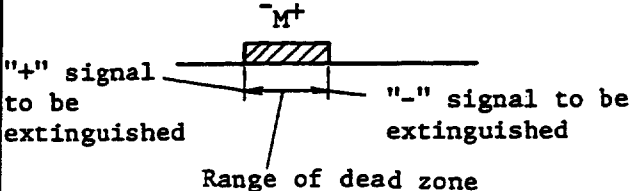
	Item	Condition/Standard	Remarks
Exposure Measurement/Information	Automatic shutter speed display accuracy	Middle value of dead zone to be within $\pm 1/2EV$ as compared with standard display value	Shutter tester (J19022 - 1 J18041 - 1) Tool lens
	Range of dead zone for automatic shutter speed display	ASA value or F/No. value which indicates ± 1 step as compared with standard display value should be within $1 \pm 1/3EV$. [e.g.] 	
	Automatic over-exposure display	Setting: ASA100, LV14 When F/No. is changed from 2.8 to 2, display should change from "2000" to "2000".	
	Manual shutter speed display change-over accuracy	1/2000 - 1/2 : 2000 - 2 1 - 8 : 1 ⁻ - 8 ⁻ X : 80 B.T : -	
	Manual correct exposure display accuracy	Middle value of dead zone to be $\pm 1/4EV$. \triangle as compared with standard display value. Correct exposure : \bar{M}^+ Overexposure : M^+ Underexposure : \bar{M}	
	Range of dead zone for manual correct exposure display accuracy	ASA value or F/No. value for correct exposure display to be within $0.5 \pm 0.3EV$ \triangle as compared with standard display value 	

					Item	Condition/Standard			Remarks
	Ready-light display	Display		Ready-light	Shutter speed	Visual inspection			
		Mode							
		Auto		ON	"80"				
		Manual	X and faster				Stroke power is ON.	⚠ " M 80" ⚠ Set shutter Speed M ⁺	
Slower than X									
Synch Contact	Insulating resistance	More than 30MΩ			Contact & insulation tester (J19028-1)				
	Contact efficiency	More than 70% (Standard time: 1ms)							
	X time-lag	0.41 - 1.2ms (Full-open time: more than 1.5ms)			Flash synch tester (J19008-2)				
Viewfinder	Infinity (∞) focus	-15" - +30" (The value before shutter-cocking should not vary after shutter-cocking.)			J18010 J19001				
	Diopter	-1.0 ± 0.5 dpt.			Diopter bar				
	Frame coverage	100 ± 0/2 % (Horizontally and vertically)			Test chart (J18006)				
	Viewfinder image inclination	Within 30'			Focusing screen (J18007)				
	Parallax error	Within 0.2mm (Horizontally and vertically)			Standard lens (J18010)				
Electrical Characteristics	Minimum operable voltage for shutter	Shutter-release button should not be depressed under a voltage of 2.4 - 2.5V.			DC regulated power supply (J19024)				
	Display extinguishing voltage	LCD should disappear under a voltage of 2.4 - 2.5V.			Digital voltmeter (J9003-3)				
	Electric current dissipation while illuminator operates	With release button half-depressed: Less than 17.9mA With release button fully-depressed: Less than 39.8mA (Power source voltage: 3V)			J19024 J9003-3 DC ampere meter (J9004)				
	Electric current when power switch is OFF	Less than 8 μA							

	Item	Condition/Standard	Remarks		
Film-winding	Horizontal play of film-advance lever	Play of the tip of the lever to be within 1.2mm with the lever pulled-out △			
	Return action of film-advance lever	When the lever is released from the almost fully stroked position, it should not returned flush to the body. △			
	Film-winding torque	Without loading film: Less than 2kgcm (Maximum) With film loaded: Less than 4kgcm (Maximum)	Torque driver Trix Pan film Neopan SS film		
	MD coupling winding torque	Without loading film: Less than 1.0kgcm (Maximum) With film loaded: Less than 1.4kgcm (Maximum)	-ditto-		
	Spool	Spool friction: 220 - 380g △			
	Sprocket	Play of the tip of sprocket teeth: within 1.2mm △ Sprocket teeth position: 31.85±0.4mm △	Sprocket teeth positionig gauge (J18064)		
Film-rewinding	Rewind button	Without loading film	Vernier		
				Height from button surface	Power
		Ready-to-rewind position Full stroke		△ Less than 3.6 △ More than 3.7	
		Power required to depress the button at the end of the roll of film: Less than 3kg	Balance spring		
Shutter-speed Dial	Alignment of shutter-speed dial index	More than a half breadth of index should align with figures at every click-stop setting.	Visual inspection		
	Cancellation of Time exposure	The closing curtain should start traveling before the shutter-speed dial is reset to "X" or "B" click-stop setting.			

	Item	Condition/Standard			Remarks
Shutter-release button	Shutter-release button stroke/power		Stroke (mm)	Power for Shutter-release (g)	J15189
		Release-metering SW : ON	Display appears 0.5 ± 0.2	70 ± 50	
		Release SW : ON	Shutter-release 1.2 ± 0.2	440 ± 60	
		Full stroke	1.5 ± 0.2		
	When measuring the stroke, denote the top surface of the release button under the normal condition as "0".				
	16-second hold	LCD should disappear in 16 ± 1 seconds after the release-metering switch is OFF.			Stopwatch
Mirror 45° Angle	Clearance at mirror locking-up	Clearance between the reflex-mirror and the mirror stopper to be less than 0.3mm.			Visual inspection
	Mirror-rising position	Clearance between the top surface of the reflex-mirror and the mirror stopper to be 3.5 - 11.8mm Δ			- ditto -
	Mirror 45° position	Vertically: Within $\pm 30'$ Horizontally: Within $\pm 30'$			J18037 J18070 Vertical collimator
	Strain of mirror-surface	Defocused index line of collimator: breadth: Within $\pm 6'$ Δ			Vertical collimator
Metering mirror	Clearance at mirror locking-up	No-clearance can be observed between the metering mirror and the stopper (#139).			Visual inspection
Meter coupling	Rotation torque of aperture coupling ring	When turned toward minimum aperture: Less than 950gcm When turned back toward minimum aperture: 80 - 350gcm			Torque gauge for AI lens and body (J18058)
	Rotation angle of meter coupling lever	Starting position: $52^\circ \pm 0$ 1° Maximum rotation angle: More than 113.5°			



	Item	Condition/Standard	Remarks
Frame Counter	Starting position	① Open camera back ② Close camera back. On this condition, dot "0" at the starting position should align with the index.	Visual inspection
	Counter Switch	Shutter speed should change as follows when the frame counter indicated is changed from 0 to 1. ① Auto : 1/80 sec. ② Manual, X or faster : 1/80 sec. ③ Manual, slower than X: Set shutter speed	Shutter tester Tool camera back (J15187)
	Mechanical shutter-release operation	① 1/2000 - 1/125 : Mechanical shutter speed (1/55) ② 1/60 - 8 : Set shutter speed	Shutter tester
Self-timer	Selftimer operation	Shutter-release condition via self-timer ① When power switch is ON: LED and should go on and off at a 2HZ rate for 8 sec. and go on and off at a 8HZ rate for 2 sec. before the shutter is released.	Visual Inspection
Lens Mount	Aperture lever	① Height: Before shutter-cocking; Less than 3.75 . Δ After shutter-cocking; 3.1 ± 0.15 Δ Balance; More than 0.15 Full stroke; More than 6.1.	Aperture lever positioning gauge (J18004)
		② Depth: 5.3 - 6.3mm (from bayonet surface)	Aperture lever depth gauge (J18042)
		③ Horizontal position: 18.7 ± 0.35 - 0.3 (from the center of the camera)	
		④ Power required to operate the lever at 3.1 position	Aperture lever weight gauge (J18003)

	Item	Condition/Standard	Remarks
Lens Mount	Metal back focus	Extension: 46.67 ± 0.02 (internal film-rail) Parallelness: Within 0.02mm Balance of height between internal and external film-rail: 0.23 ± 0.02 mm	Vernier Balance spring
	Lens release/lock pin	Protrusion above bayonet surface: 0.7 - 1.2mm Fit tolerance: Within 0.05mm Power required to operate the pin: 350 - 500g	
Strobe	Automatic control signal	Δ 730 - 916mv (Central value: $820V \pm 0.163EV$) LV14; shutter open	Lightbox Tool lens Dummy strobe Standard reflector
Shooting Test	Picture size	$24 \begin{smallmatrix} + 0.8 \\ - 0 \end{smallmatrix} \text{mm} \times 36 \begin{smallmatrix} + 0.8 \\ - 0 \end{smallmatrix} \text{mm}$	50/1.4 lens
	Frame-to-frame space	Normally manual film-advance operation or motor link-up operation (S or C setting): 1.8 ± 0.5 mm; Max. - Min. ≤ 0.5 Manual film-advance operation made strongly/weakly: Max. ≤ 3.0 Min. ≤ 0.5	
	Multiple exposure	Frame overlap: Less than 0.3mm	
	Erroneous sprocket rotation	Blurred/doubled image should not be visible on the exposed film when the shutter is released with finger-pressure (0 - 400g) applied to the film-advance lever, and with the motor drive.	
	Image cut-off	When mounted 1200m/f11 lens with the focusing unit, no image cut-off should occur on the exposed film with various shooting angles.	
	Supplement: (Exposure Measurement/Information)		
	Automatic underexposure display	Setting: ASA100, LV4 When F/No. is changed from 11 to 16, display should change from "8" to "8-".	

Section 6 Tools

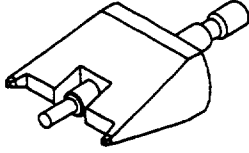
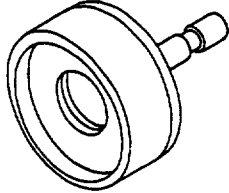
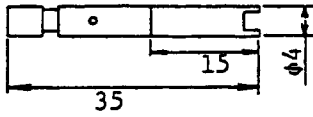
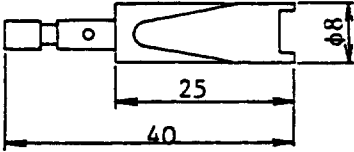
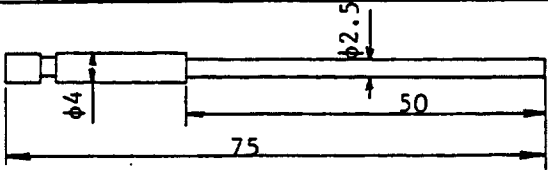
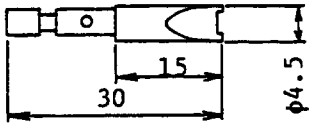
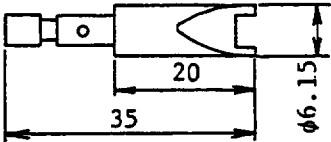

40FB用工具 Tool List

工具番号 Tool No.	工具名称 Name	略 図 (単位mm) Illustration (mm)	区 分 Class	備 考 Remarks
J11156	電源ロックレバー押え環 # 353用回線器 Screwdriver for #353		A	
J11157	巻上げレバー飾り環 # 349用回線器 Screwdriver for #349		A	
J11158	多重操作レバー飾りビス # 416用回線器 Screwdriver for #416		A	Common use:F3 #173
J11159	基板押え環 # 207用回線器 Screwdriver for #207		C	
J11161	スプール上軸 # 584用ドライバー Screwdriver for #584		C	
J11162	ミラーアップ運動軸 # 168用回線器 Screwdriver for #168		B	
J11163	絞り込み釘ナット # 163用回線器 Screwdriver for #163		C	
J14017	スプリングピンB # 945用やっこ Pliers for #945		B	

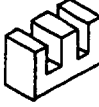
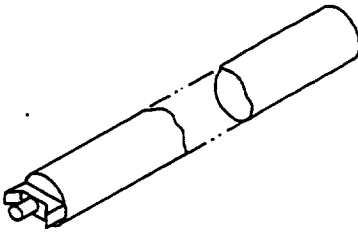
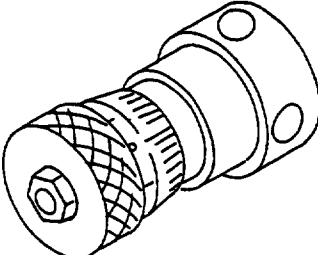
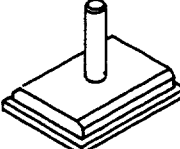
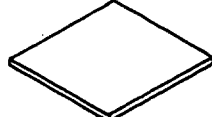
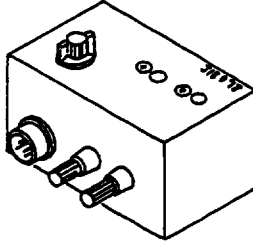
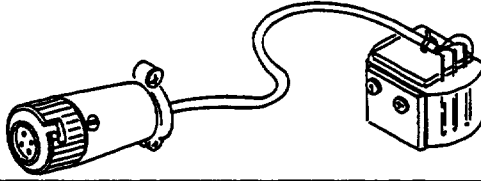
工具番号 Tool No.	工具番号 Name	略 図 (単位 mm) Illustration (mm)	区 分 Class	備 考 Remarks
J15187	裏蓋代用工具 Tool camera back		A	
J15188	可変抵抗 校正用ドライバー Screwdriver for VR adjustment		A	
J15189	押釘マイクロ Micrometer		B	
J15191	ファインダーカバー Finder cover		A	
J15196	標準反射板 Standard reflector		A	
J18078	DAS 導通チェック工具 DAS conductivity check tool		A	
J18077	ストロボダミー工具 Dummy strobo		A	
J18080	完成品チェック工具 Final inspection tool		A	

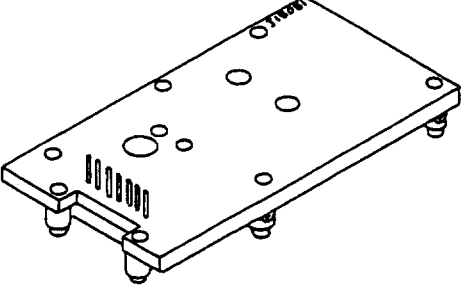
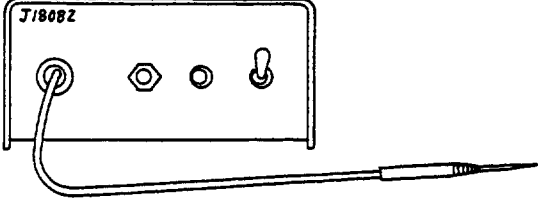
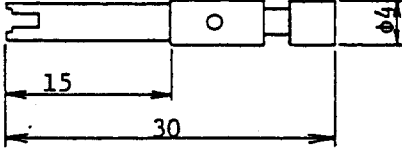
工具番号 Tool No.	工具名称 Name	略 図 (単位 mm) Illustration (mm)	区 分 Class	備 考 Remarks
J18081	前ボディーダミー工具 Dummy front unit base		-	
J18082	液晶駆動波形 チェック工具 L/C display check tool		A	
J11122	FPC 押えナット ≒ 38 . # 11 用 回 蝶 器 Screwdriver for #38 & #11		A	⊕ Common use: F2 #445, #840