

作成承認印

配布許可印



One•Touch FCA47001
Zoom90
AF

One•Touch FCA47201
Zoom90
AF QUARTZ DATE

REPAIR MANUAL

Nikon | NIKON CORPORATION
Tokyo, Japan

Copyright © 2000 by Nikon Corporation.
All Rights Reserved.

無断転載を禁ず !!

SPECIFICATIONS

Model·Lens·Automatic focus	M 1
Shutter·Finder	M 1
Speed light function·Self-timer	M 2
Film speed·Film advance	M 3
Date function·Power supply	M 4
Size·Weight	M 5
AF step table	M 6
Program graph	M 7
AE coupling graph WIDE	M 8
AE coupling graph TELE	M 8

1. SPECIFICATION

(1) Model

·Zoom lens built-in automatic focus 35mm AE lens shutter Flash built-in compact camera

(2) Picture size

·24mm×36mm

(3) Zoom photography lens

·Focal length W 39.92mm~T 86.53mm

·FNO W F4.94~T F10.82

·Lens construction FC 4 groups and 4 lenses RC 2 groups and 2 lenses

(4) Automatic focus

·Infrared active triangular distance measurement method

·Distance measurement step number: AF step number 26+Forced infinity step+Macro step

·Focus lock function is prepared. (Release button pre-release function)

(5) Focusing range (Focusing range is the distance from the whole surface of the front barrel.)

·W 0.745m~∞ (0.8m from the film surface)

·T 0.710m~∞ (0.8m from the film surface)

·SM

(6) Shutter type

·Electromagnetic drive (Step motor) program electronic shutter

·AE coupling range WIDE Ev6.0: 1/2 sec ~ Ev16.0: 1/250 sec

 TELE Ev6.0: 2 sec ~ Ev18.0: 1/250 sec

·FM coupling range WIDE F4.94 ~ T F10.815 (WIDE conversion)

·Daytime sync control is the small aperture priority electronic FM which is determined by slope flash or mountain-top sync.

(7) Finder

·Real image zoom finder

Field of viewfinder 80% or more and less than 100% in vertical and horizontal directions

Magnification W 0.336 times

Diopter -0.7 diopter

Eye point 15mm from the appearance surface (16mm from the lens surface)

Information in finder: AF target mark

Near distance compensation mark: at 0.7m (TELE)

(8) Speed light mode

·Normal mode (1~5 is changed by the mode button.)

1. Auto
2. Distant view mode (with Flash prohibition)
3. Flash prohibition
4. Forced flash
5. Slow sync (with Forced flash)

·Macro mode

1. The lens barrel is moved to W end by pressing the macro button.
2. The photography lens is set to the nearest distance.
3. The macro button blinks in orange. (4Hz)
4. The speed light mode is changed to "Forced flash".

(9) Self-timer

Red eye reduction

·Press the self-timer button to set the red eye mode, and the high pressure lamp is turned on for 1 second before opening.

·The red eye relief mode can be used with each of speed light modes at the same time.

In the flash prohibition mode, the high pressure lamp should not be turned on.

Self-timer

·Electronic control self-timer: Release occurs after 10 seconds since start.

·How to operate: Press the self button on the upper surface of the camera. After the

self-timer is displayed in LCD, press the release button.

·Operation display: 1Hz for 7 seconds. For another 3 seconds, it is turned on.

(The red eye lamp is used.)

·How to release: If releasing the self-timer during operation, set the main switch button to "OFF".

Mode change order

·OFF Red eye mode Red eye+Self-timer

(10) Speed light

- GNo: 10 (ISO100·m)
- Recycling time: Approx. 7 seconds

(11) Release mechanism

- Electromagnetic release by the conductive rubber contact
- Pre-release function
 - AF lock
 - AE lock

Photography possible display: The green LED is turned on at the left of the finder on the rear of the camera.

BC display: The picture of the battery mark is displayed in LCD on the upper surface of the camera.

(12) Setting of film speed

- ISO: The film speed is automatically set by DX code.
- For other films except DX, the film speed is set to "ISO100".
- ISO100: 25, 32, 40, 100, 125, 160, No DX code
 - 200: 50, 64, 80, 200, 250, 320
 - 400: 400, 500, 640, 1600, 2000, 2500
 - 800: 800, 1000, 1250, 3200, 4000, 5000

(13) Film advance

- The 1st frame to be photographed is automatically set by closing the camera back.
- 1st frame is wound by pressing the release button.
- Automatic rewinding is done when the film end is detected.
- If you hope to rewind the film halfway, press the MU button on the upper surface of the camera.
- After the film end is detected or after the MU button is pressed, the lens barrel is automatically housed and rewinding starts.
- The film counter is displayed in LCD on the upper surface of the camera. (Coupling operation of forward calculation and backward calculation at rewinding)

(14) Film advance quantity

- Approx. 15 of 24-exposure film rolls: when speed light 50% is used at normal temperature

(15) Auto. power OFF

- If operation is not done by the operating button after the main switch is turned on, the lens barrel is automatically pushed in after approx. 3 minutes and the power is turned off.
- All the modes except the red eye reduction mode are reset.

(16) Information in LCD

- Battery condition (BC display)
 - Warning cannot be used.
- Frames to be photographed (It is displayed with the counter numerals.)
- Remaining frames to be rewound (It is displayed with the counter numerals.)
- Rewinding completion display (It is displayed with the counter numerals.)
- Self-timer display
- Speed light photography mode display

(17) Lens cover

- The lens cover is opened and closed between the push-in position and W end.

(18) Date function

- LCD display quartz digital clock is built in.
- Auto. calendar from 1998 to 2049.
- Date copy display is changed by 5 modes.
 - 1. Year/month/day mode → 2. Day/hour/minute mode → 3. Copy prohibition mode →
 - 4. Month/day/year mode → 5. Day/month/year mode
- Lithium battery CR2025 (1 pc.) is used as a power supply which is separate from the power supply for the camera.

(19) Power supply of camera

- Lithium battery CR2 (3V), 1 pc, is used.

(20) Camera size

- 117 (width) × 64.4 (height) × 50.4 (depth) mm
- 117 (width) × 64.4 (height) × 53.8 (depth) mm [QD specification]

(21) Weight

- 215g
- 225g [QD specification]

(22) Error display

Error display			How to release
1	Lens barrel NG	n 2	<p>When the lens barrel is in the middle of WIDE and TELE, press lightly the release button, press the zoom button, main switch button and MU button and open and then close the camera back. Consequently the initial condition is set.</p> <p>When the lens barrel is in the push-in position, press the main switch button, open and then close the camera back and press the MU button. Consequently the initial condition is set.</p> <p>If the same error is displayed though the above procedure is performed, disassemble and repair the camera.</p>
2	Shutter NG	n 3 n 1	<p>Load the battery again, open and then close the camera back, press the MU button and press lightly the release button. Consequently the initial condition is set.</p> <p>If the same error is displayed though the above procedure is performed, disassemble and repair the camera.</p>
3	FFS NG		<p>If FFS fails, the operation stops just under the condition and "E" blinks.</p> <p>The error condition is released by opening the camera back.</p>
4	1 frame advance NG		<p>If 1 frame advance fails, automatic rewinding starts and, when rewinding is ended, "0" blinks.</p> <p>The error condition is released by opening the camera back.</p>
5	Rewinding NG		<p>If an accident is caused during rewinding and so emergency stop occurs, the counter blinks at that time to show that the camera is in an abnormal condition.</p> <p>Open the camera back in a dark box, take out the film and close the camera back.</p>

[AF step table]

Step	Step distance (m)	Change-over distance (m)	Front lens group forward length(mm)	Lens stop
1	13.9616	—————	0.06	Forced infinity
2	8.3243	6.9656	0.10	AF infinity
3	5.9923	5.2429	0.14	x
4	4.6624	4.2106	0.18	x
5	3.8407	3.5238	0.22	o
6	3.2564	3.0335	0.26	o
7	2.8399	2.6661	0.30	o
8	2.5126	2.3801	0.34	o
9	2.2614	2.1547	0.38	o
10	2.0575	1.9673	0.42	o
11	1.8845	1.8107	0.46	o
12	1.7432	1.6795	0.50	o
13	1.6195	1.5659	0.54	o
14	1.5158	1.4825	0.58	o
15	1.4443	1.4024	0.62	o
16	1.3625	1.3155	0.66	o
17	1.2714	1.2389	0.70	o
18	1.2088	1.1788	0.74	o
19	1.1510	1.1251	0.78	o
20	1.1003	1.0760	0.82	o
21	1.0531	1.0315	0.86	o
22	1.0112	0.9909	0.90	o
23	0.9718	0.9545	0.94	o
24	0.9367	0.920	0.98	o
25	0.9034	0.8874	1.02	o
26	0.8734	0.8590	1.06	o
27	0.8449	0.8320	1.10	o
28	0.8190	0.8066	1.14	o
29	0.7943	—————	1.18	o
30	0.7407	—————	1.22	MACRO

At step 1, 2, 5 and 30, the latch position accuracy must be ± 0 .

[Program graph]

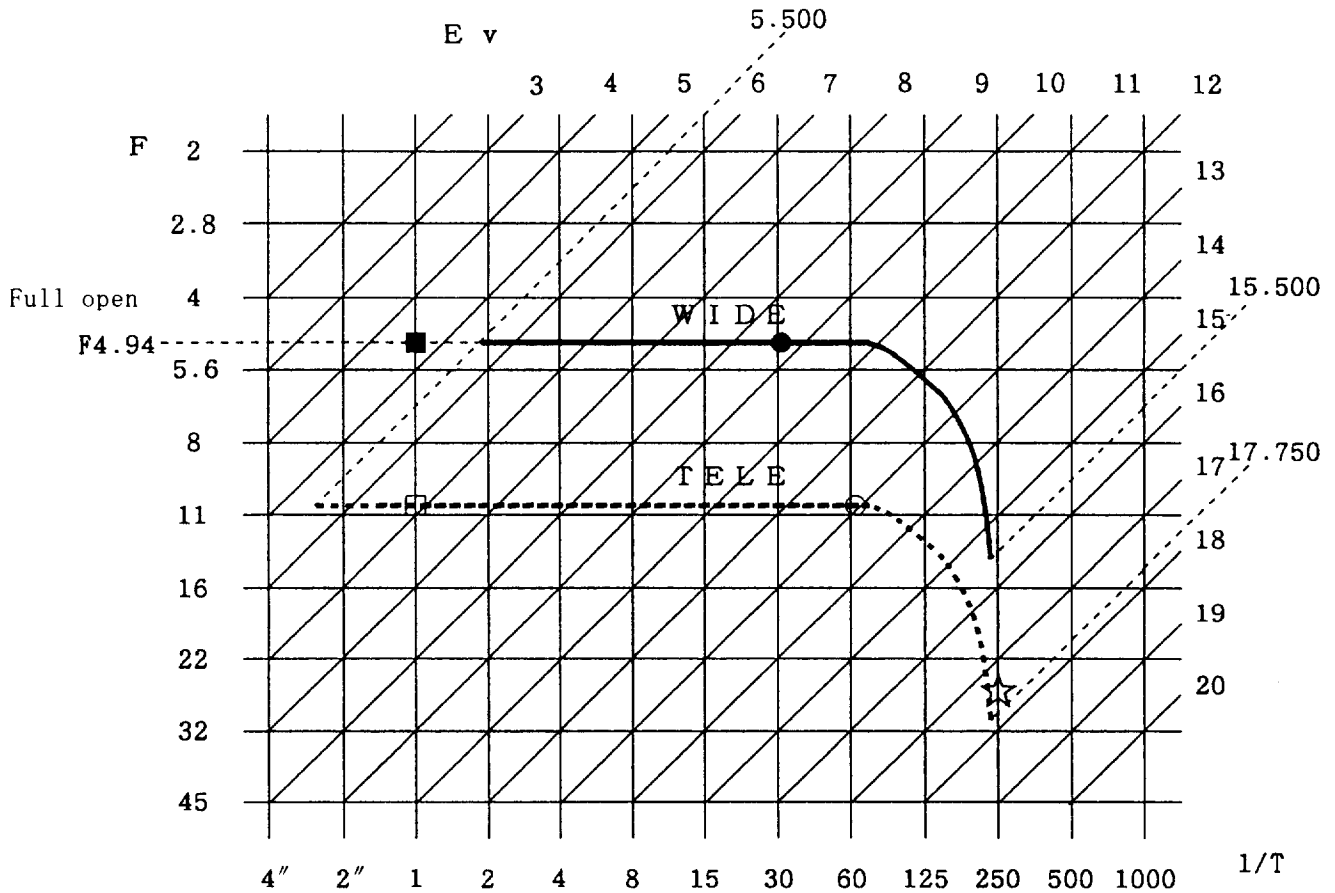

- : Speed light flash point (WIDE) ○ : Speed light flash point (Equivalent to TELE)
- : Slow sync (WIDE) □ : Slow sync (Equivalent to TELE)
- ☆ : Macro mode (Equivalent to F26)

- In other modes except the above, control is done according to the program curves in the graph.
- Converted values should be used for TELE.
- The above values should be expressed in consideration of 0.5 over-shift.
- The flash point should be mentioned at Ev 10.125 (WIDE conversion) for WIDE side and Ev 11.125 (WIDE conversion) for TELE side.
- In the slow sync mode, only under the condition of $B_v \leq 1$, $E_v \geq 5.00$, the above expressed control is done.

[AE coupling graph] WIDE

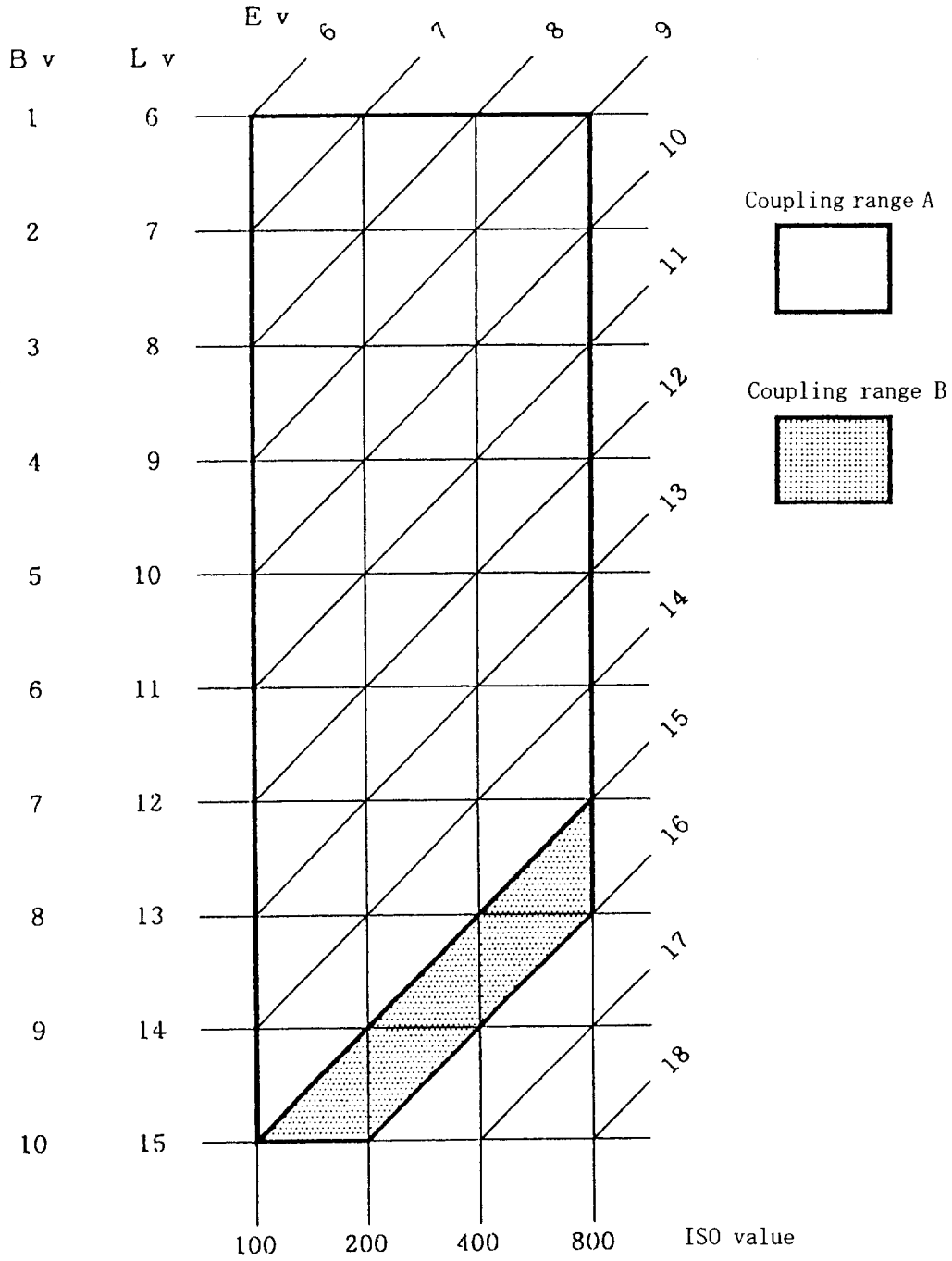

[AE coupling graph] TELE

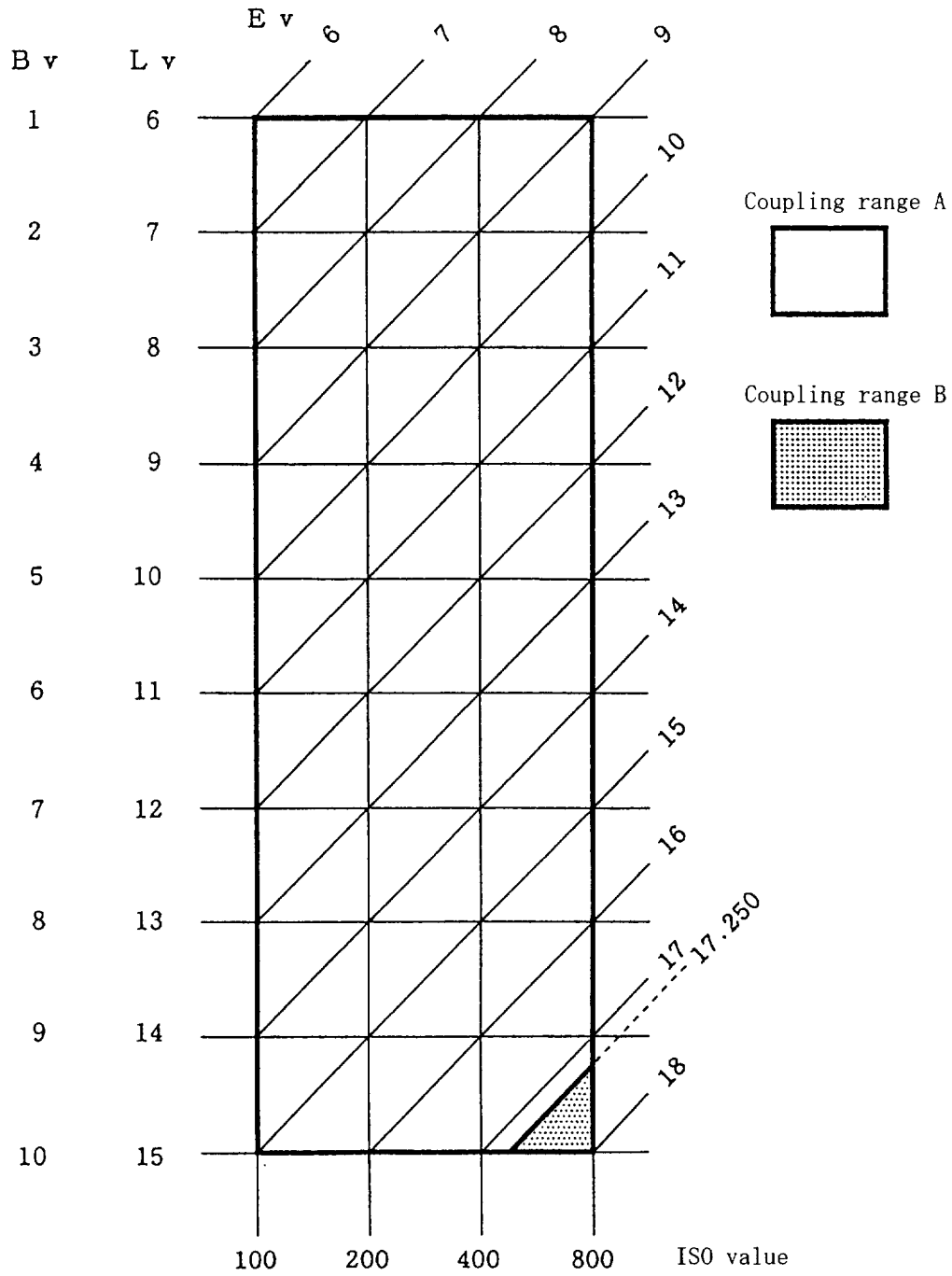

DISASSEMBLING/ASSEMBLING/ADJUSTMENT

1. DISASSEMBLING

Removal of side cover	D 1
Removal of front cover	D 2
Discharge of main condenser	D 3
Removal of camera back	D 3
Removal of AF unit	D 4
Removal of finder	D 5
Removal of zoom mechanism unit	D 6
Removal of speed light unit	D 6
Removal of lens barrel	D 7
Removal of film advance mechanism unit	D 7
Disassembly of lens barrel	D 8

2. ASSEMBLING/ADJUSTMENT

Shutter·FC lens	A 1
RC lens·Straight guide A	A 2
Lens barrel A·Lens barrel B.....	A 3
Main barrel·Straight guide B	A 4
Leaf switch·Driving gear·Relay FPC	A 5
Body unit	A 6
Film advance mechanism unit	A 7
Zoom mechanism unit	A 8
Film advance mechanism unit installation·Lens barrel unit installation.....	A 9
Zoom mechanism unit installation·Speed light unit installation.....	A 1 0
Finder unit installation	A 1 2
AF unit installation	A 1 3
Wire processing	A 1 4
Finder positioning·Front cover	A 1 5
Back focus inspection and adjustment	A 1 6
AE inspection	A 1 9
AF inspection and adjustment	A 1 9
Side cover·Barrier	A 2 0

DISASSEMBLING /ASSEMBLING/ADJUSTMENT

⚠ WARNING	
	<ul style="list-style-type: none"> ● Due to its internal high voltage area, make sure to check the safety when removing the cover. ● Be sure to discharge the static electricity from the main condenser according to the instruction in the repair manual after removing the cover.

- Note:
- ① Be sure to take off the battery before disassembly.
 - ② At disassembly, make sure to memorize how to arrange the wires, how to fix the screws, and the types of used screws.
 - ③ Be sure to get yourself grounded because of the static electricity which exerts any serious adverse effect to ICs.
 - ④ Make sure which side is back or forth when taking off the gear.

1. DISASSEMBLING

- Remove the battery.

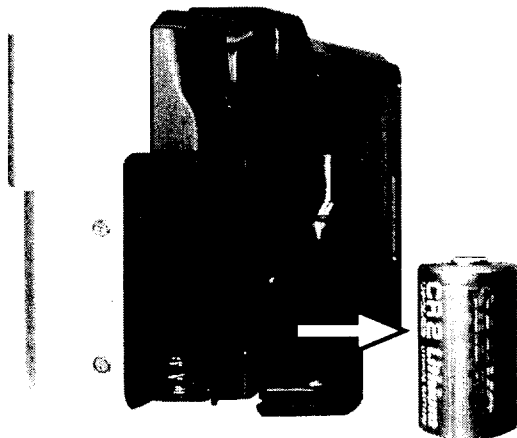

Removal of side cover

- Remove the three screws 1.
- As pushing the upper center of the side cover 2, remove it forward.

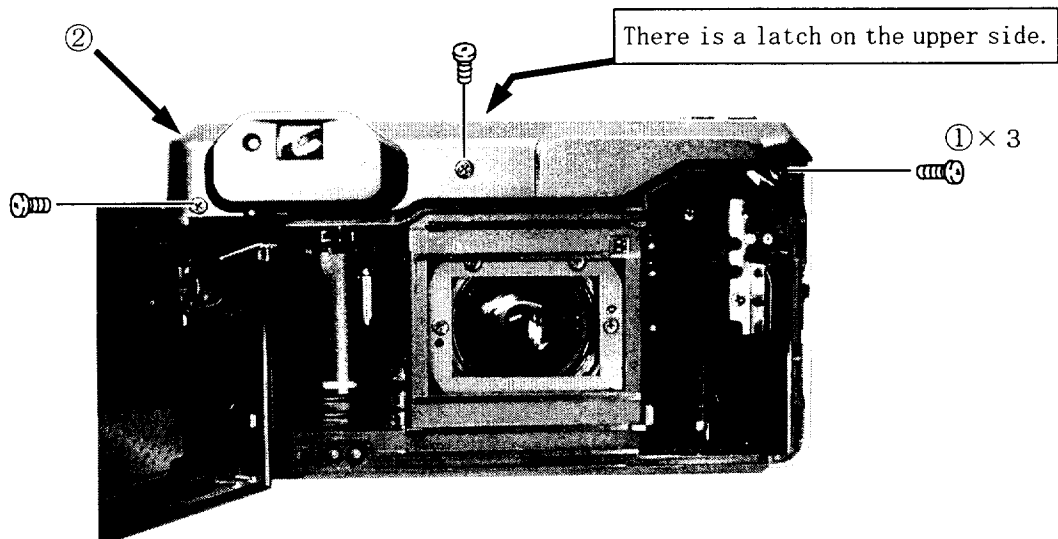

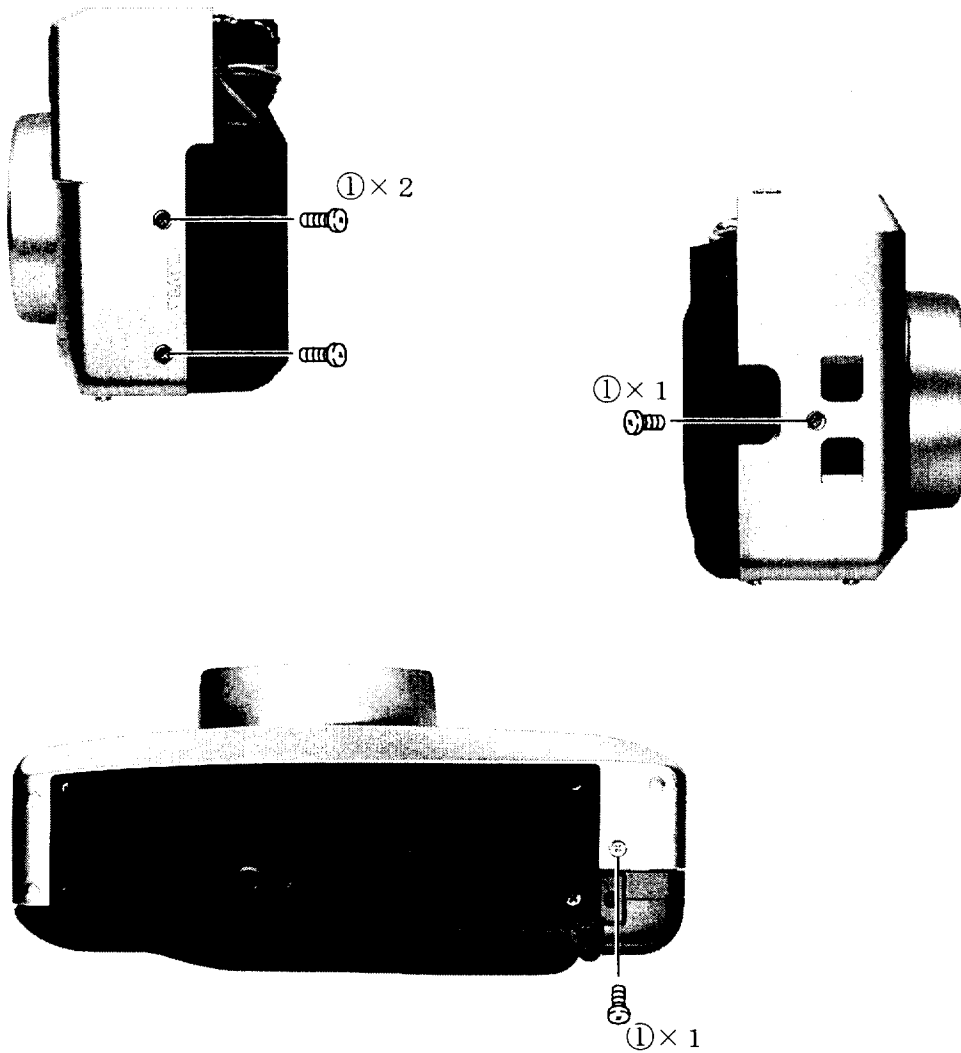

Removal of front cover

● Remove the four screws 1.

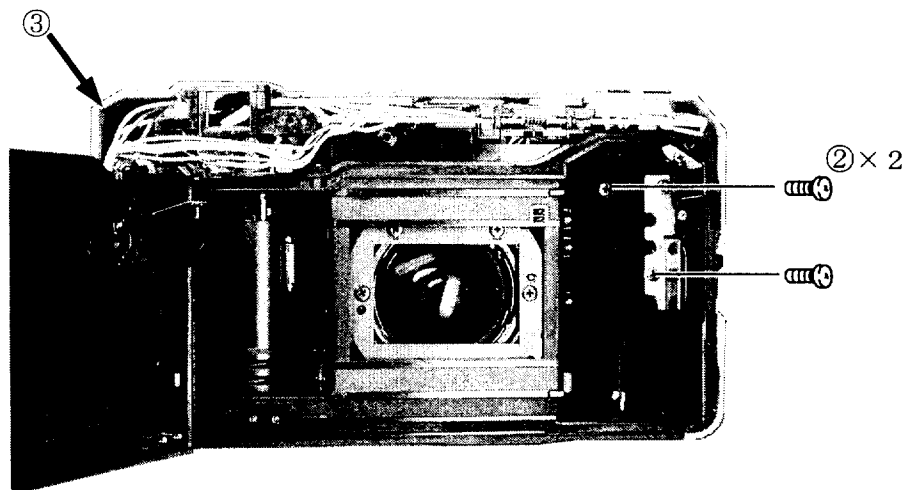

● Open the camera back, remove the two screws 2 and then remove the front cover 3.



 <h2 style="margin: 0;">WARNING</h2>	
	<ul style="list-style-type: none"> ● Due to its internal high voltage area, make sure to check the safety when removing the cover. ● Be sure to discharge the static electricity from the main condenser according to the instruction in the repair manual after removing the cover.

● Discharge the main condenser.

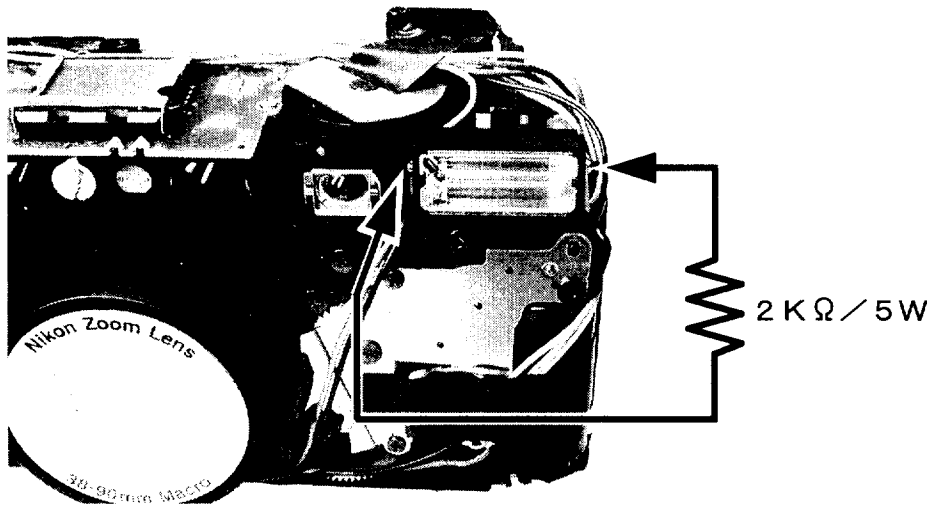

Removal of camera back

● Remove the two screws 1 and then remove the camera back 2.

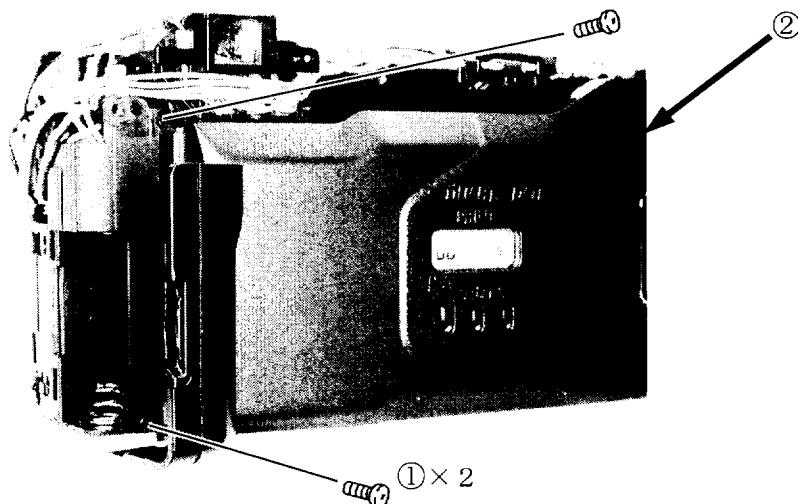

Removal of AF unit

- Remove the solder of each wire from the PCB of the AF unit 1.
- Remove the two screws 2 and then remove the press-contact 3 of FPC.

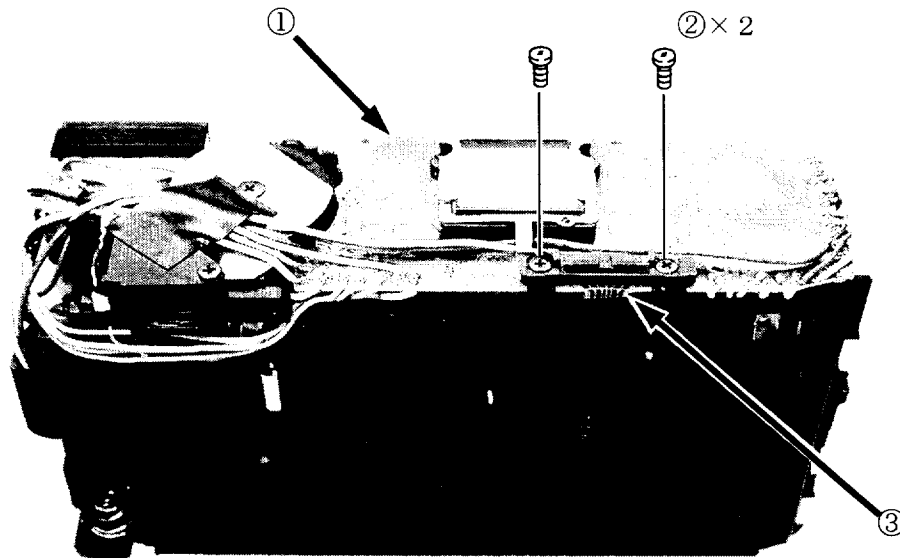

- Remove the two screws 4 and then remove the AF unit 1 upward.

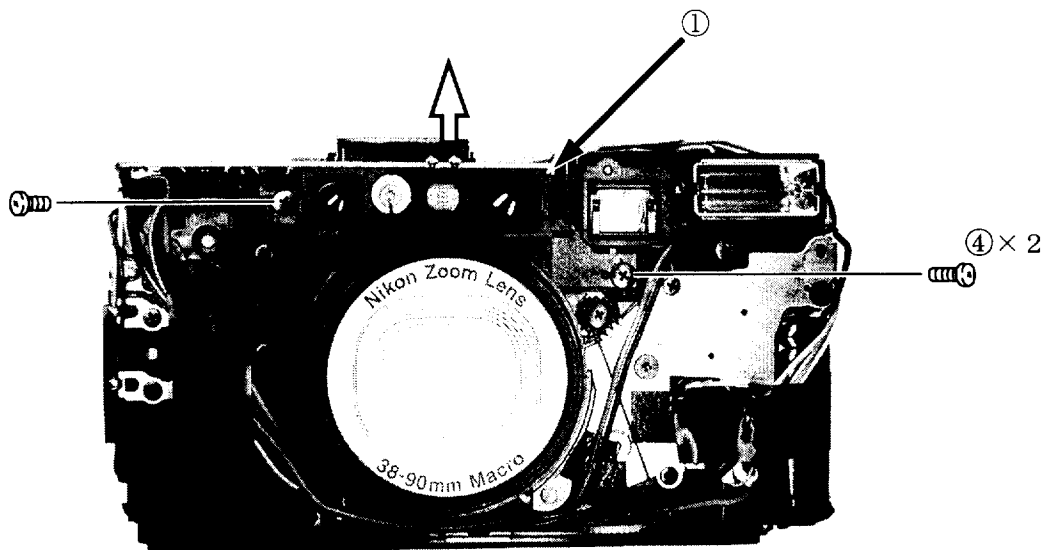

Removal of finder

- Remove the screw 1 and then remove the gear 2.

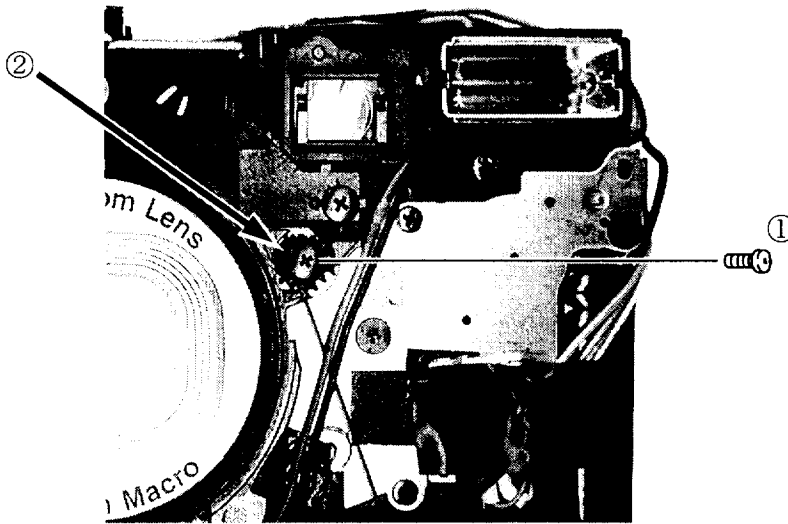

- Turn the gear 3 of the finder and remove the screw 4 from the innermost of the hole on the upper surface of the gear.
- Remove the other two screws 4 and then remove the finder 5 upward.

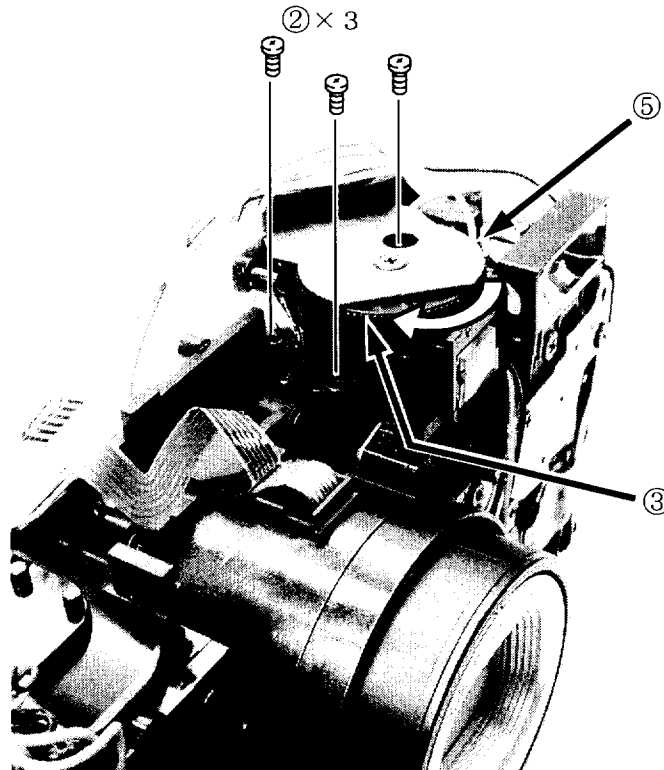

Removal of zoom mechanism unit

- Remove the arranged wires and wires on FPC 1.
- Remove the two screws 2 and then remove the zoom mechanism unit 3.

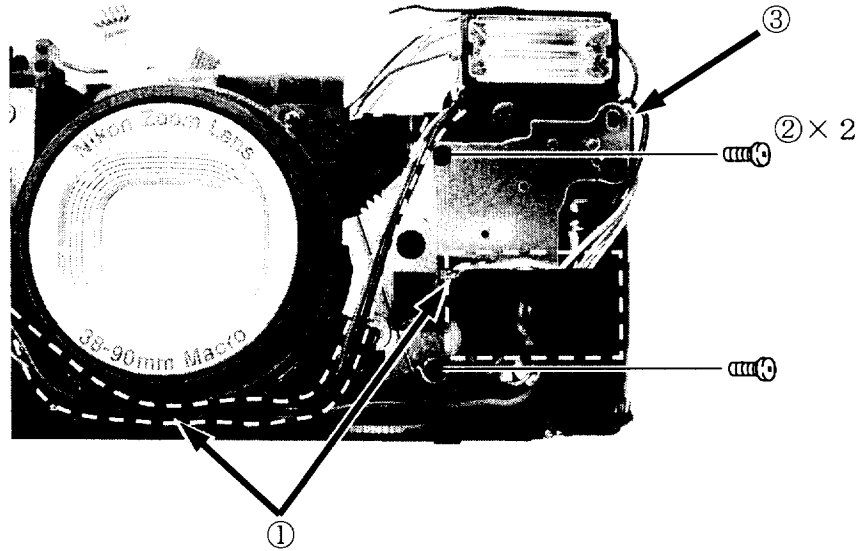

Removal of speed light unit

- Take off the tape 1 and remove the two screws 2.
- Remove the solder of the red and black wires 3 from the rear of the speed light PCB and then remove the speed light unit 4.

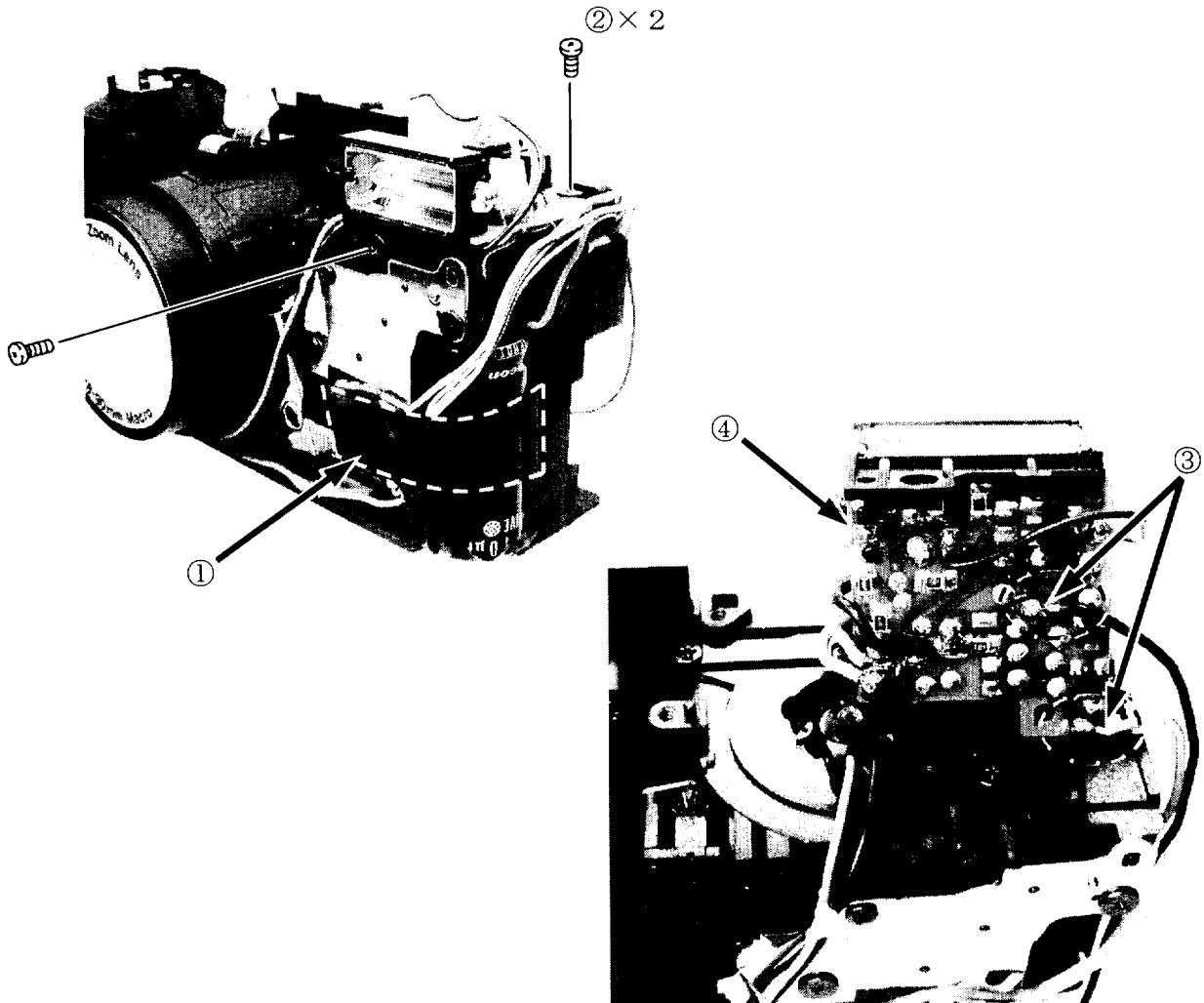

Removal of lens barrel

- Remove the four screw 1 and then remove the lens barrel unit 2.

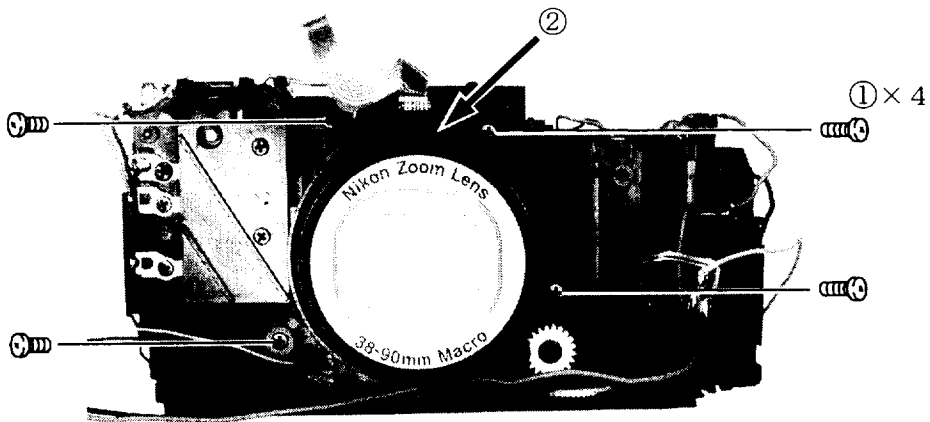

Film advance mechanism unit

- Remove the five screws 1 and one screw 2 from the bottom of the body and then remove the film advance mechanism unit 3.

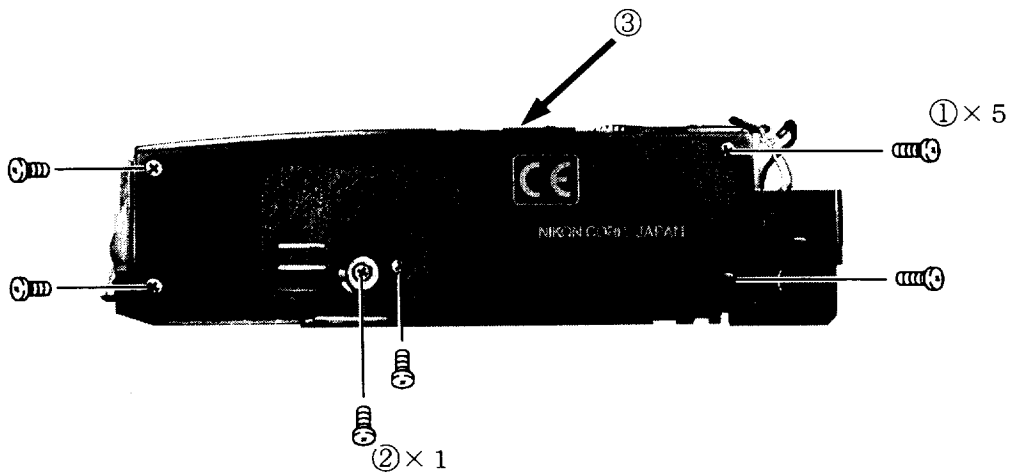

*Long screw is strictly prohibited.

Disassembly of lens barrel unit

● Remove the two screws 1 and then remove the barrier 2.

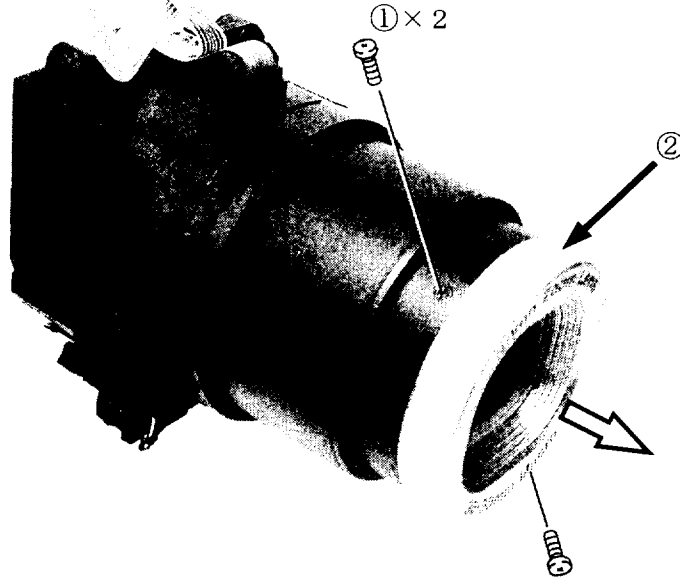

● Remove the two screws 1 and then remove the light shield mask 2.

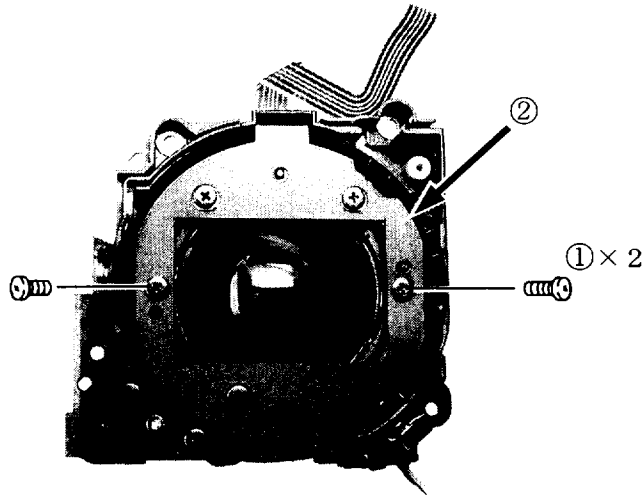

● Remove the soldering bridge 1 and then remove the relay FPC 2.

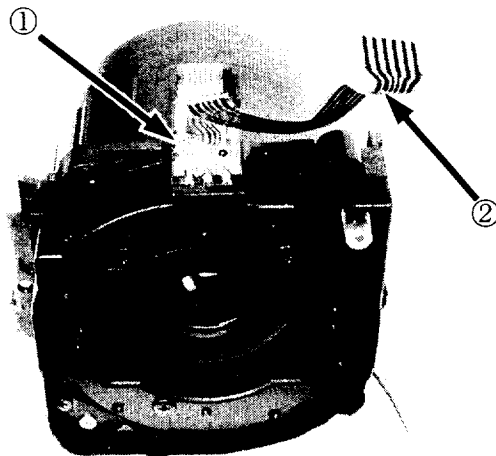

- Remove the two screws 1 and then remove the gear retainer 2.
The driving gear 3 can be removed.

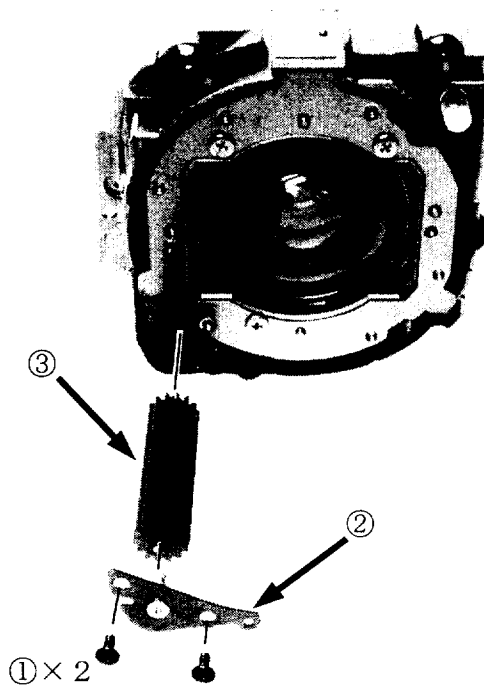

- Remove the screw 1 and then remove the leaf switch 2.

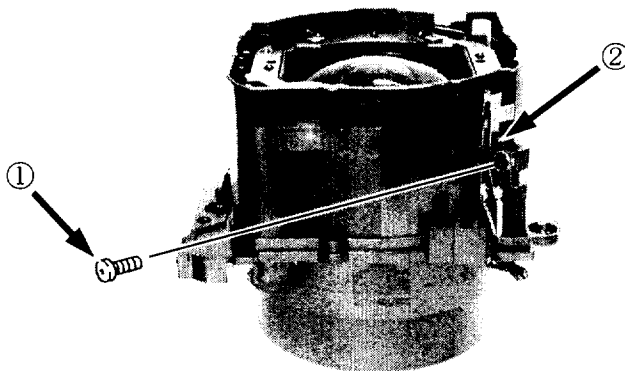

- Remove the three screws 3 and then remove the straight guide B 2.

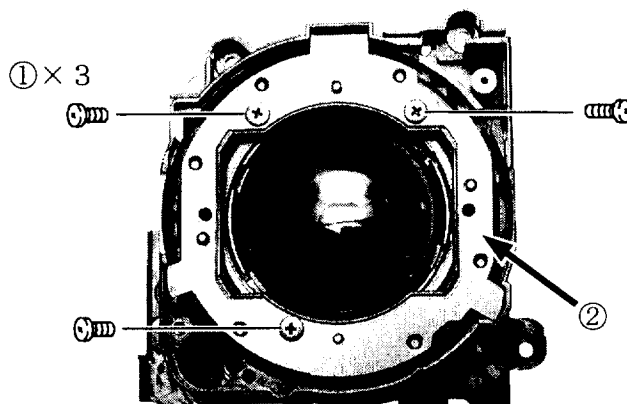

- Move the lens barrel A 1 forward to the TELE side and remove FPC.
- Turn the lens barrel A 1 counterclockwise and remove it from the main barrel 2 backward.

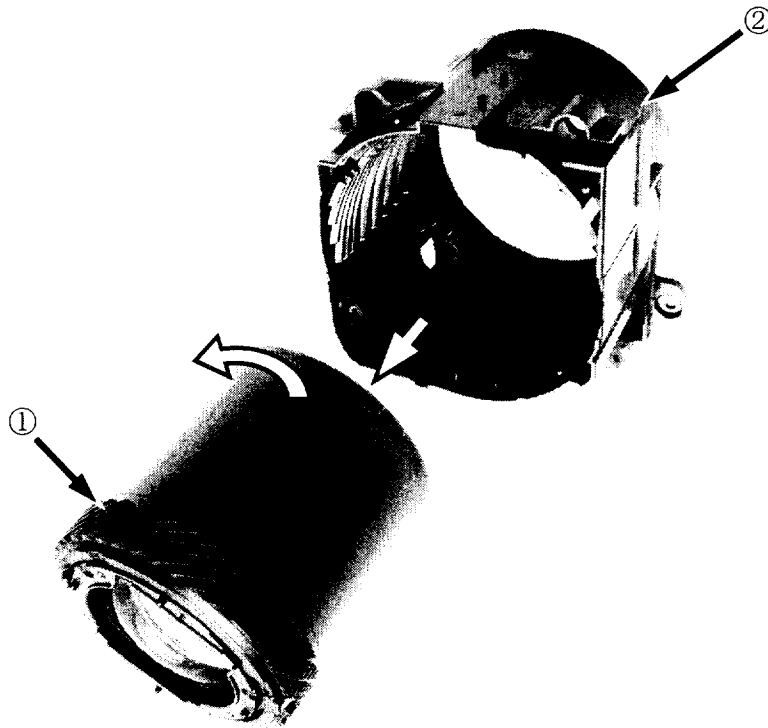

- Remove the lens barrel ring [1] and then remove the lens barrel A [2] from the lens barrel B 3 forward.

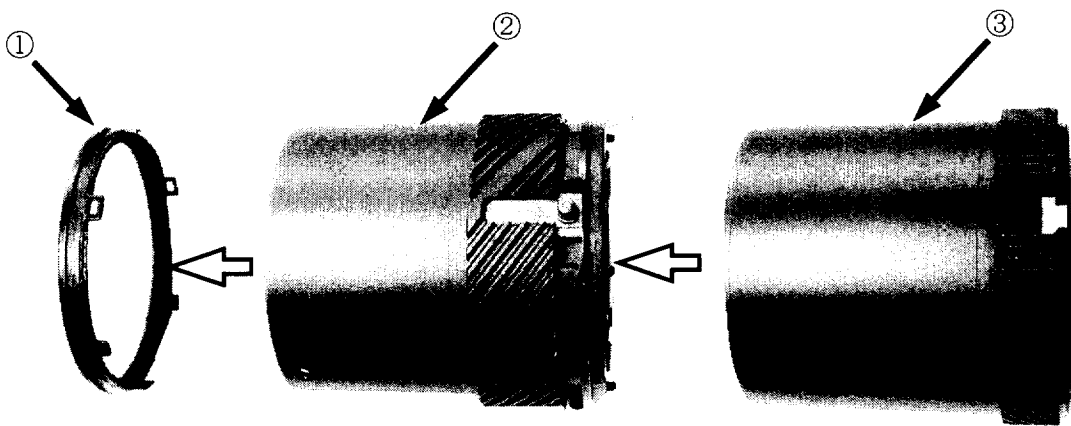

- Remove the straight guide A 2 and RC lens 3 from the lens barrel B 1.
- The RC spring 4 and RC spring plate 5 can be removed.

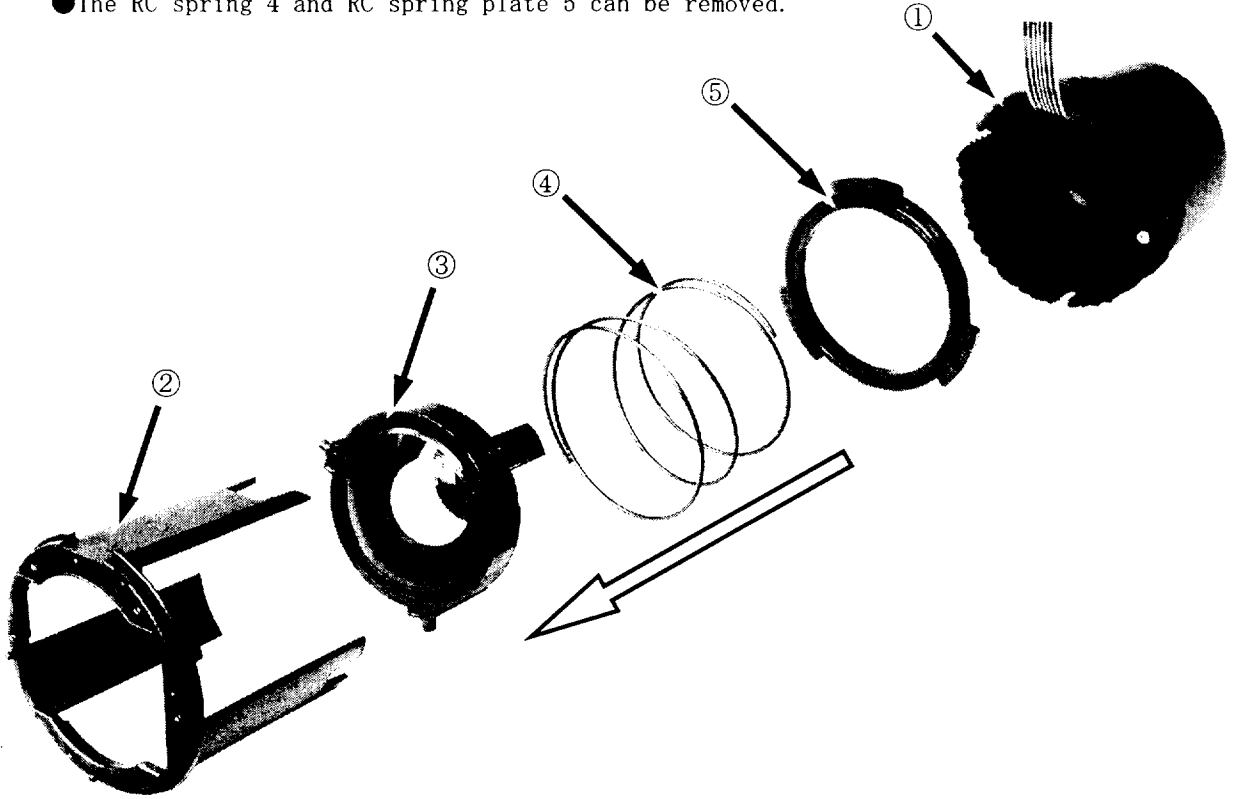

- Remove the adhesive of the lens drive ring 1 with alcohol.
- As turning the FC lens 2 counterclockwise, remove it.
- Take off the light baffle plate 3 and then remove the three screws 4.
- Remove the shutter 6 from the lens barrel B 5 backward.

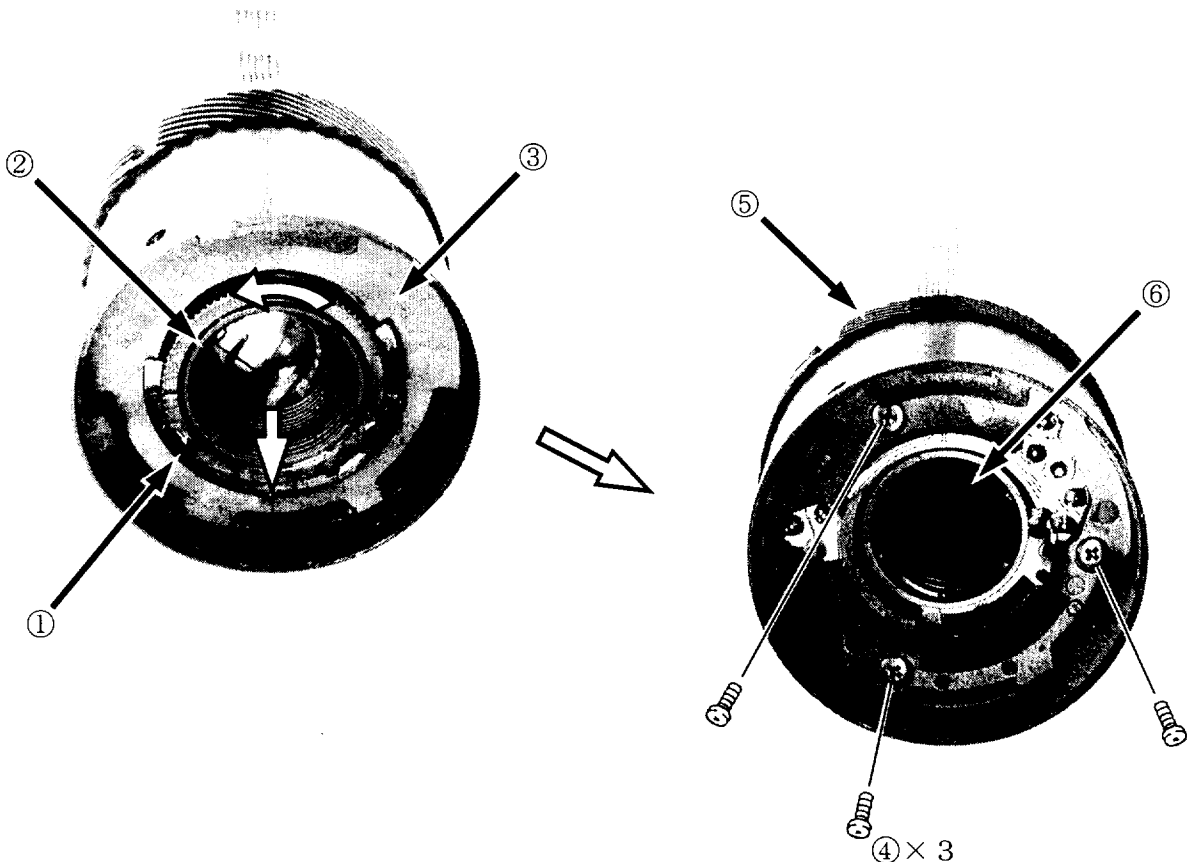

2. ASSEMBLY - ADJUSTMENT

Shutter·FC lens

- Mount the shutter 2 to the lens barrel B 1 and tighten the three screws 3.
- Adhere the light baffle plate 4.
- Mount the lens drive ring 6 to the FC lens 5 and then mount them to the shutter.

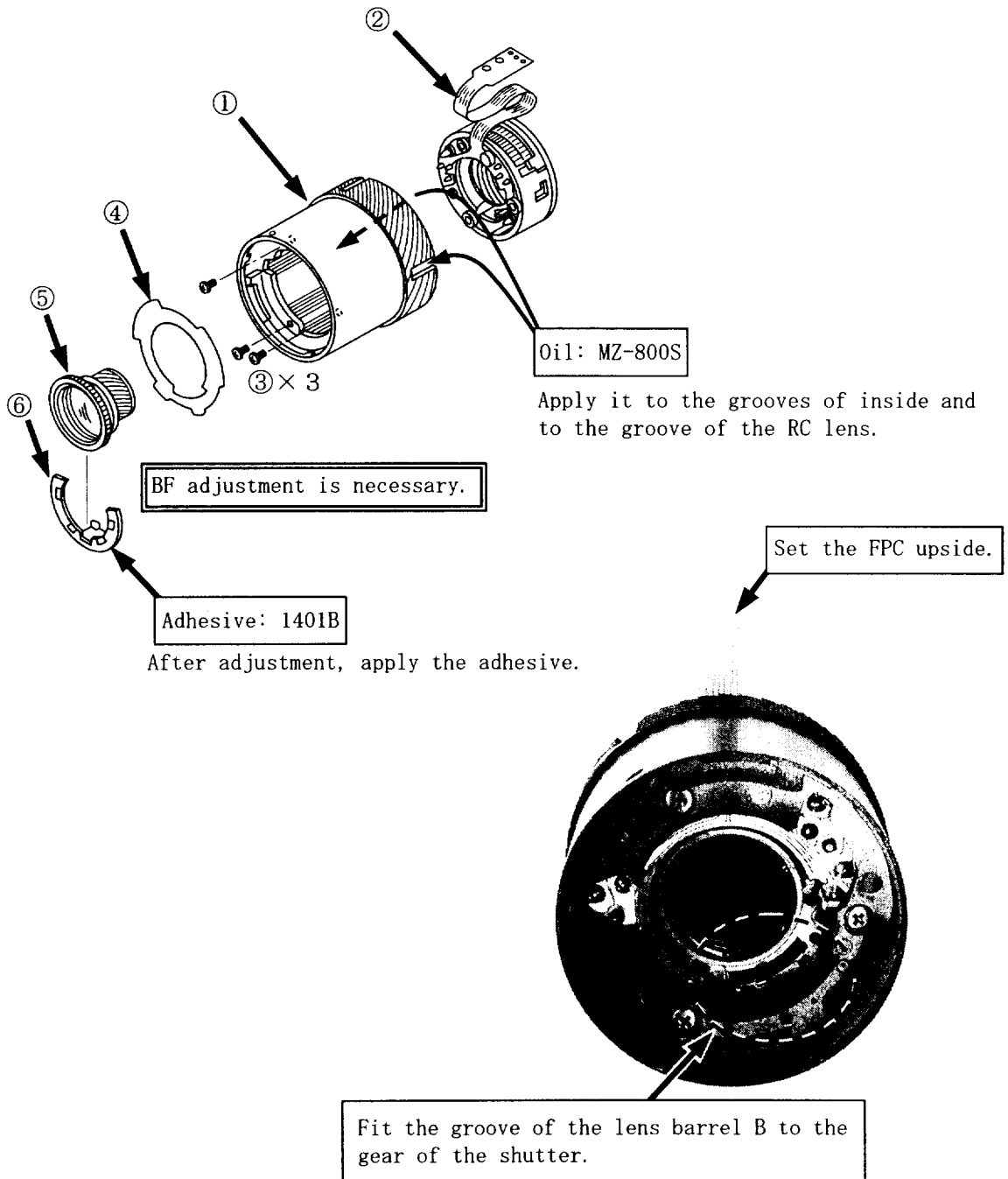

RC lens·Straight guide A

- Mount the RC spring plate 2 and RC spring 3 to the lens barrel B 1.
- Mount the RC lens 4 and straight guide A 5.

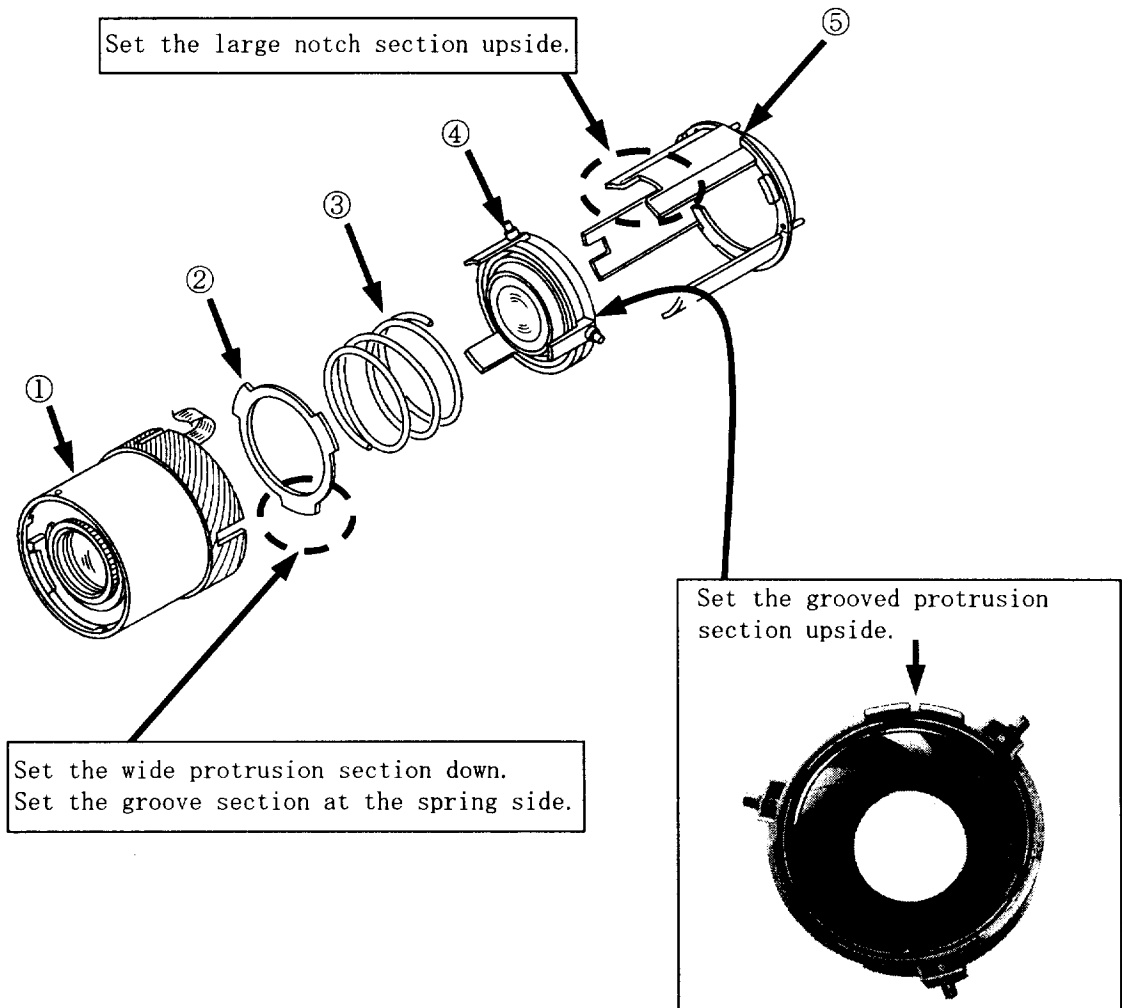

Lens barrel A · Lens barrel B

- Fit and insert the lens barrel A 2 into the lens barrel B 1 and mount it by turning counterclockwise.
- Fit the lens barrel ring 3 to the inside protrusion in the end of the lens barrel B 1 and mount it.

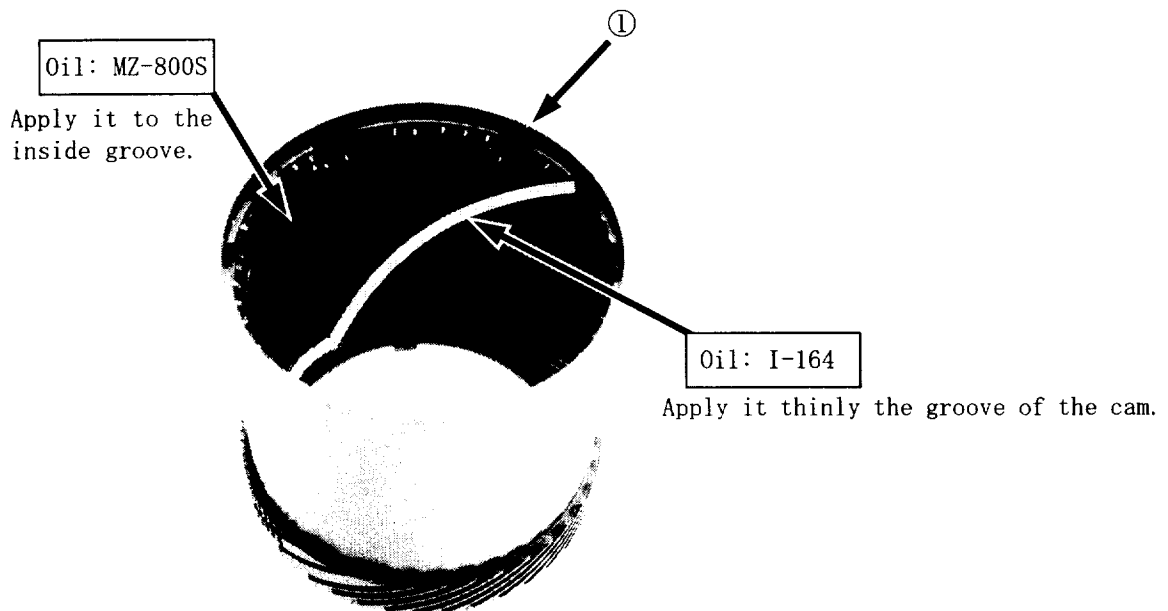
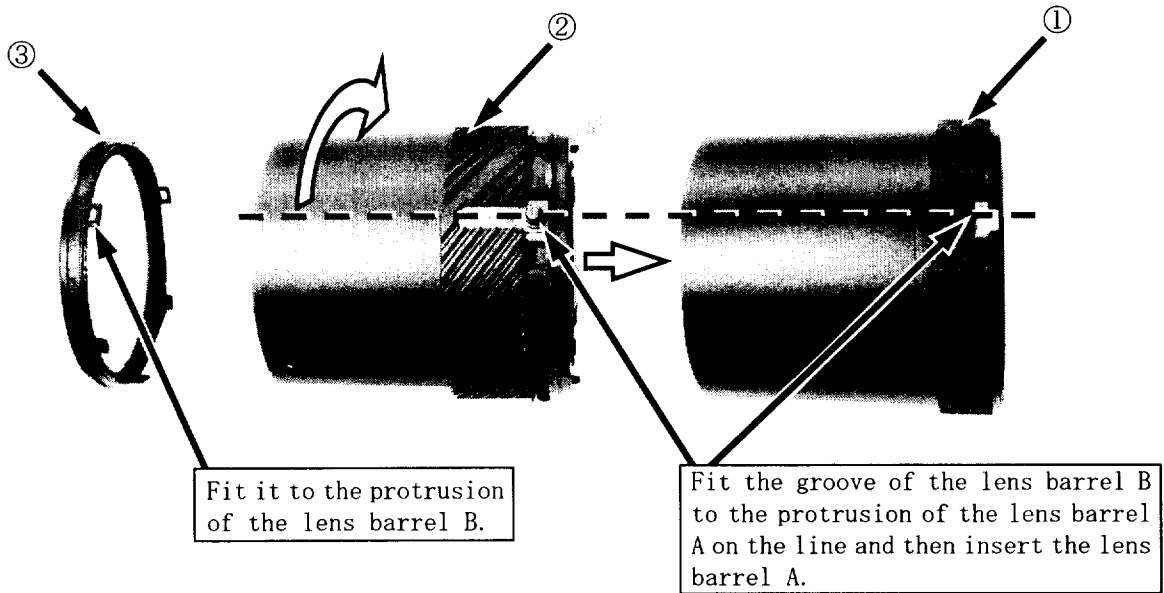

Main barrel · Lens barrel B

- Fit and insert the lens barrel B 2 into the main barrel 1 and mount it by turning clockwise.
- Move the lens barrel B 2 forward to the TELE side and mount FPC to the main barrel 1.

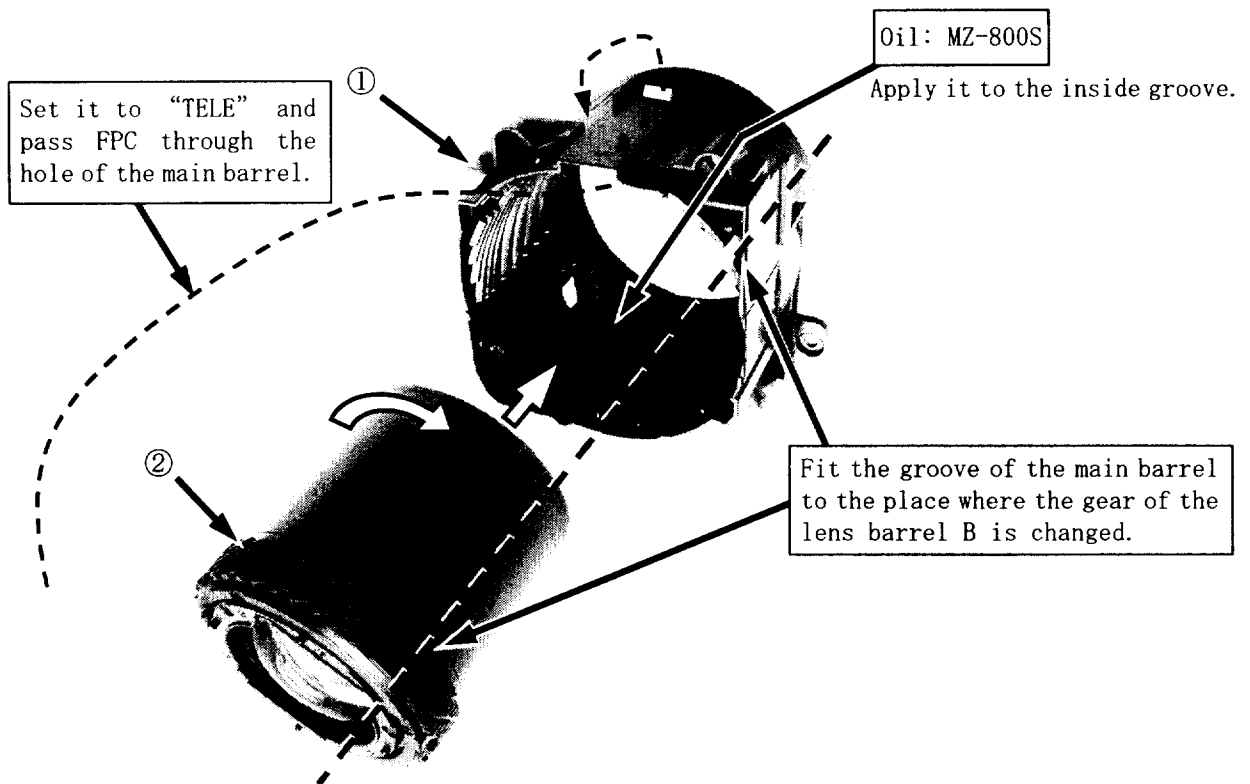

Straight guide B

- Push in the lens barrel A/B 1 by approx. 5mm and insert the straight guide B 2.
- Fit the hole of the straight guide B 2 to the boss of the lens barrel A/B 1 and tighten the three screws 3.

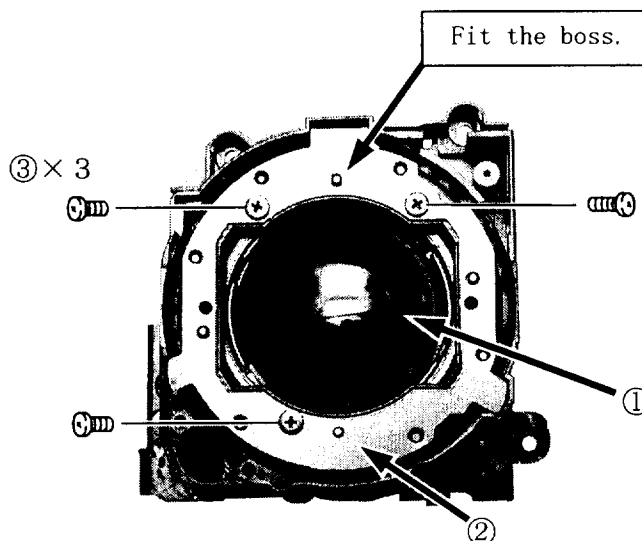

Leaf switch

- Move the lens barrel forward to the TELE side by approx. 5mm, mount the leaf switch 2 and tighten the screw 3.

Move the lens barrel forward by approx. 5mm.

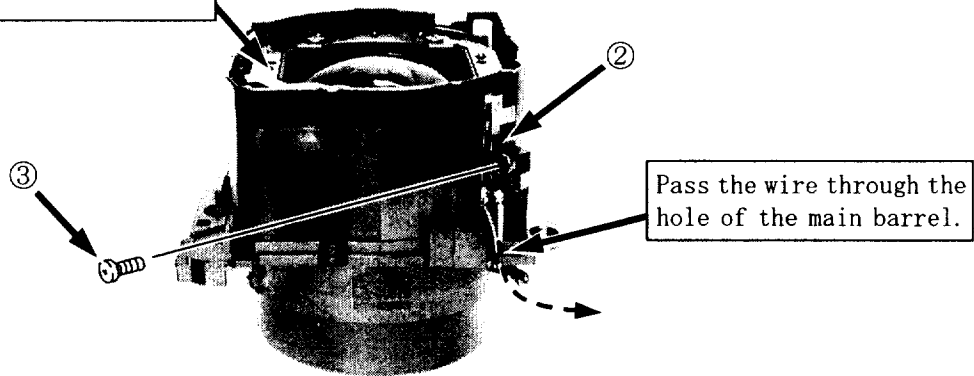

Driving gear

- Mount the gear (#123) 1 and gear retainer 2 and tighten the two screws 3.
- Mount the gear (#124) 4.

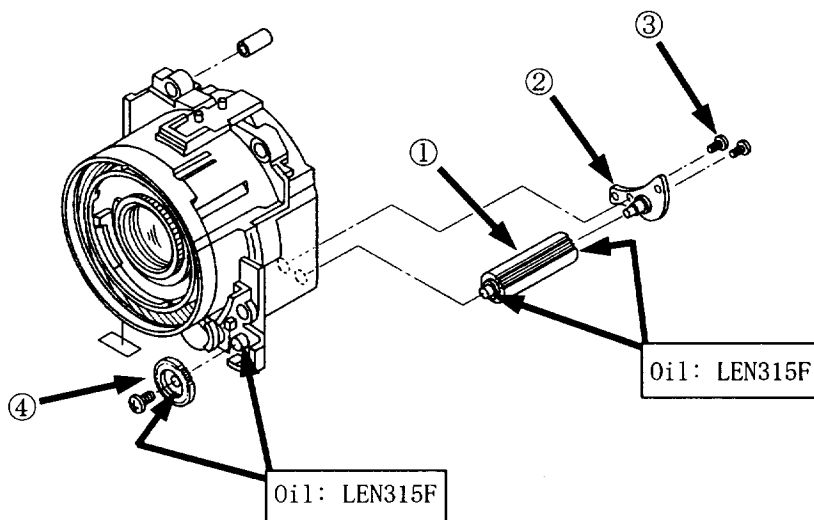

Relay FPC

- Mount the relay FPC 1 with the double adhesive tape and connect it with soldering bridge.
- Mount the light shield mask 2.

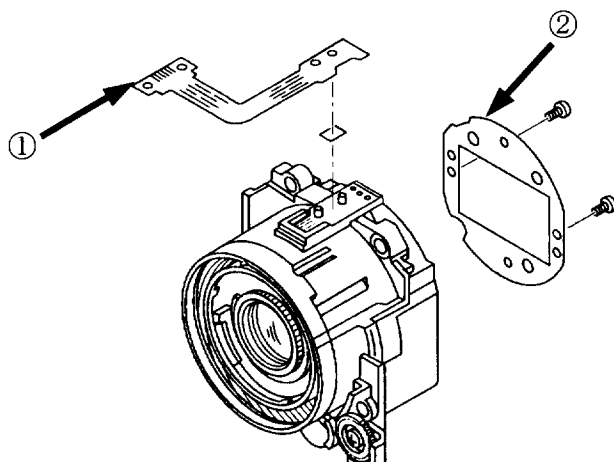

Body unit and motor unit

Be careful about motor polarity.

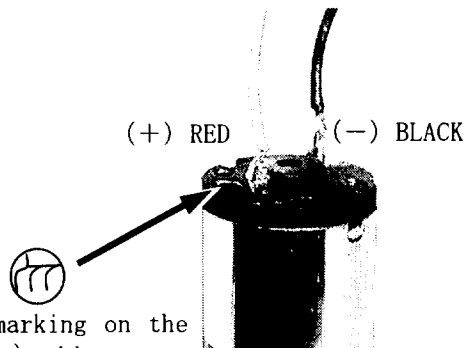

There is marking on the positive (+) side.

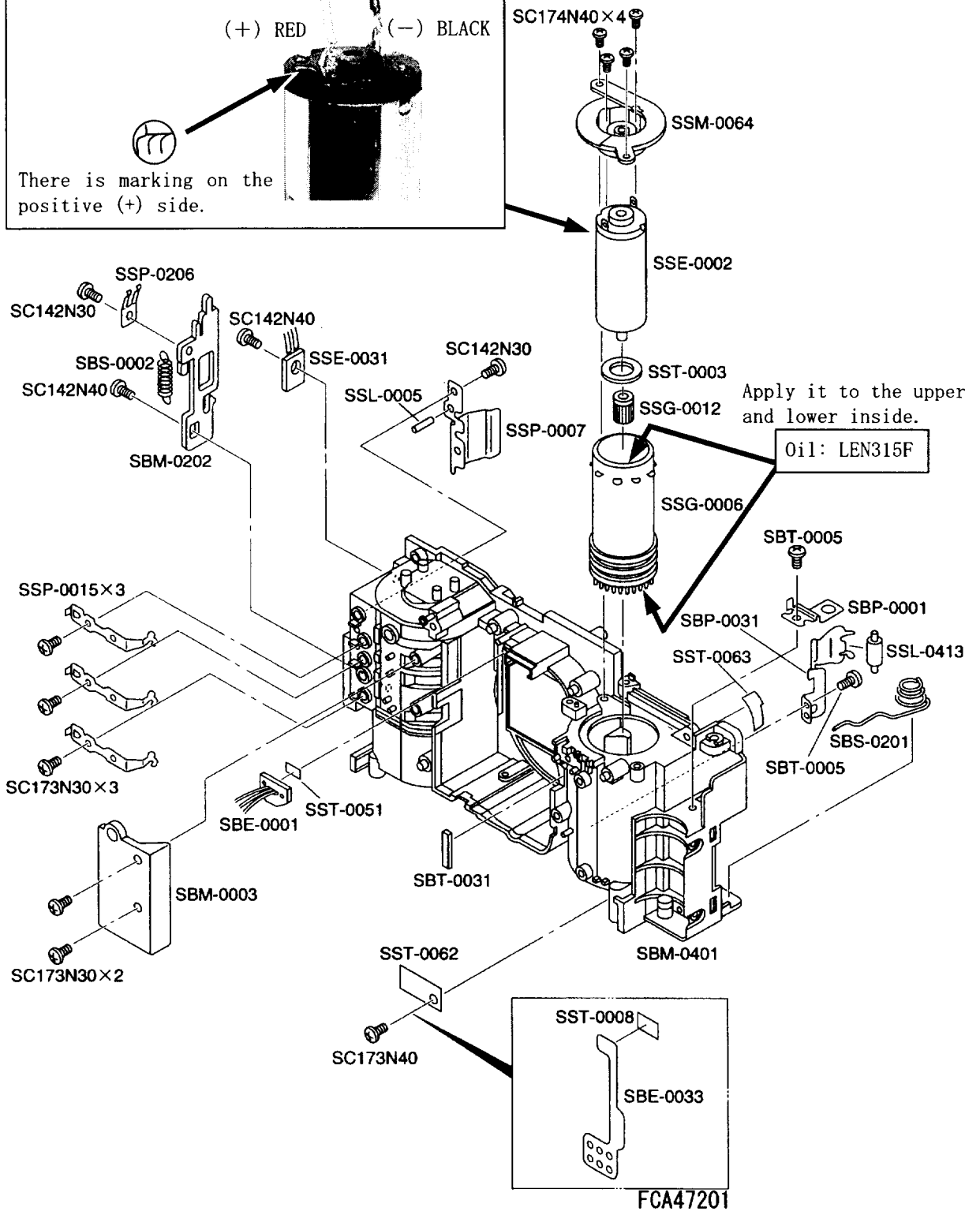

Film advance mechanism unit

●After assembling, rotate the gear [1] in right and left by hand and make sure that each gear rotates smoothly and the planetary gear operates normally.

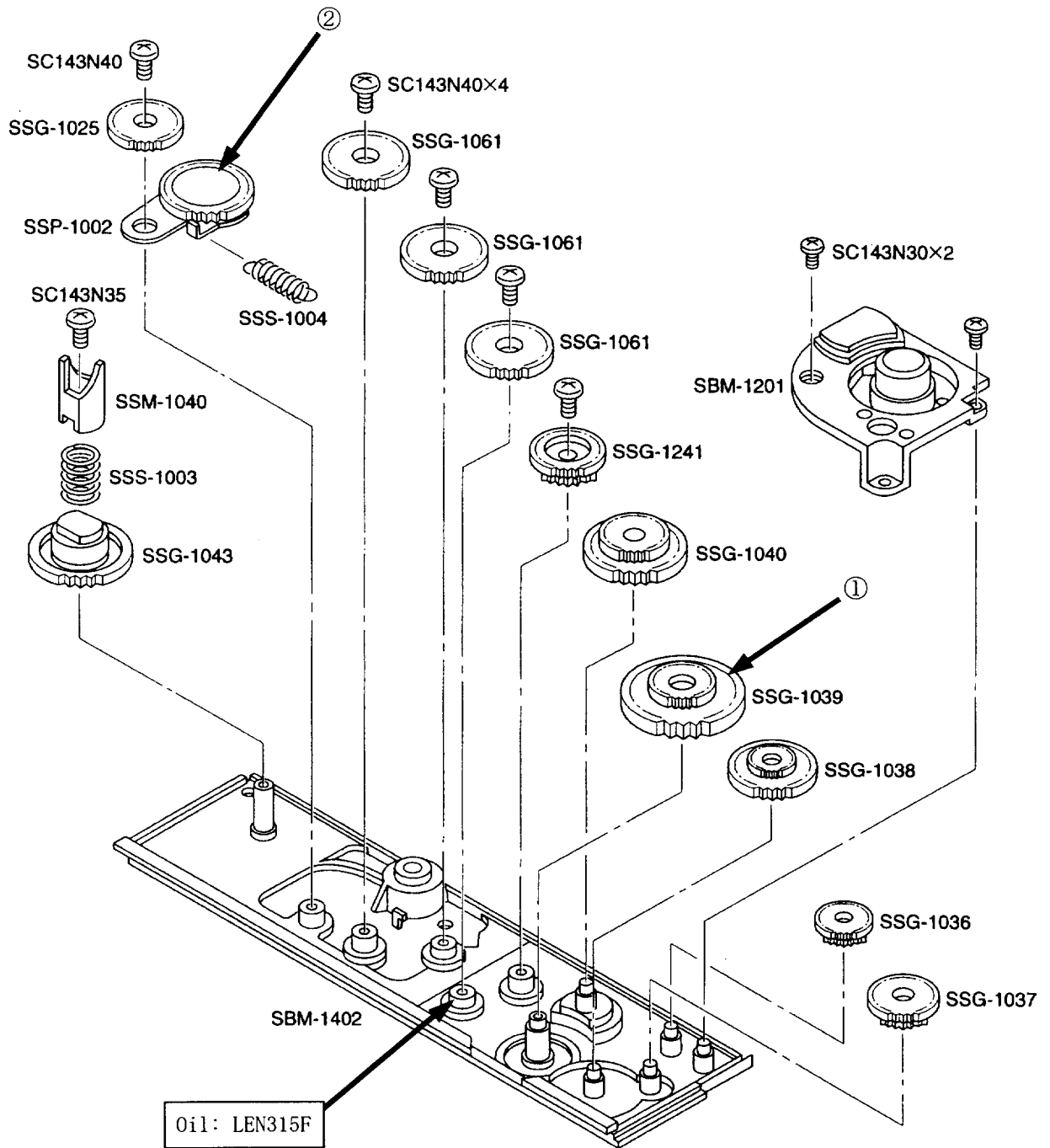

Zoom mechanism unit

●After assembling, connect the battery to the wire 1 of the motor and make sure that abnormal noise does not occur in normal and reverse rotation.

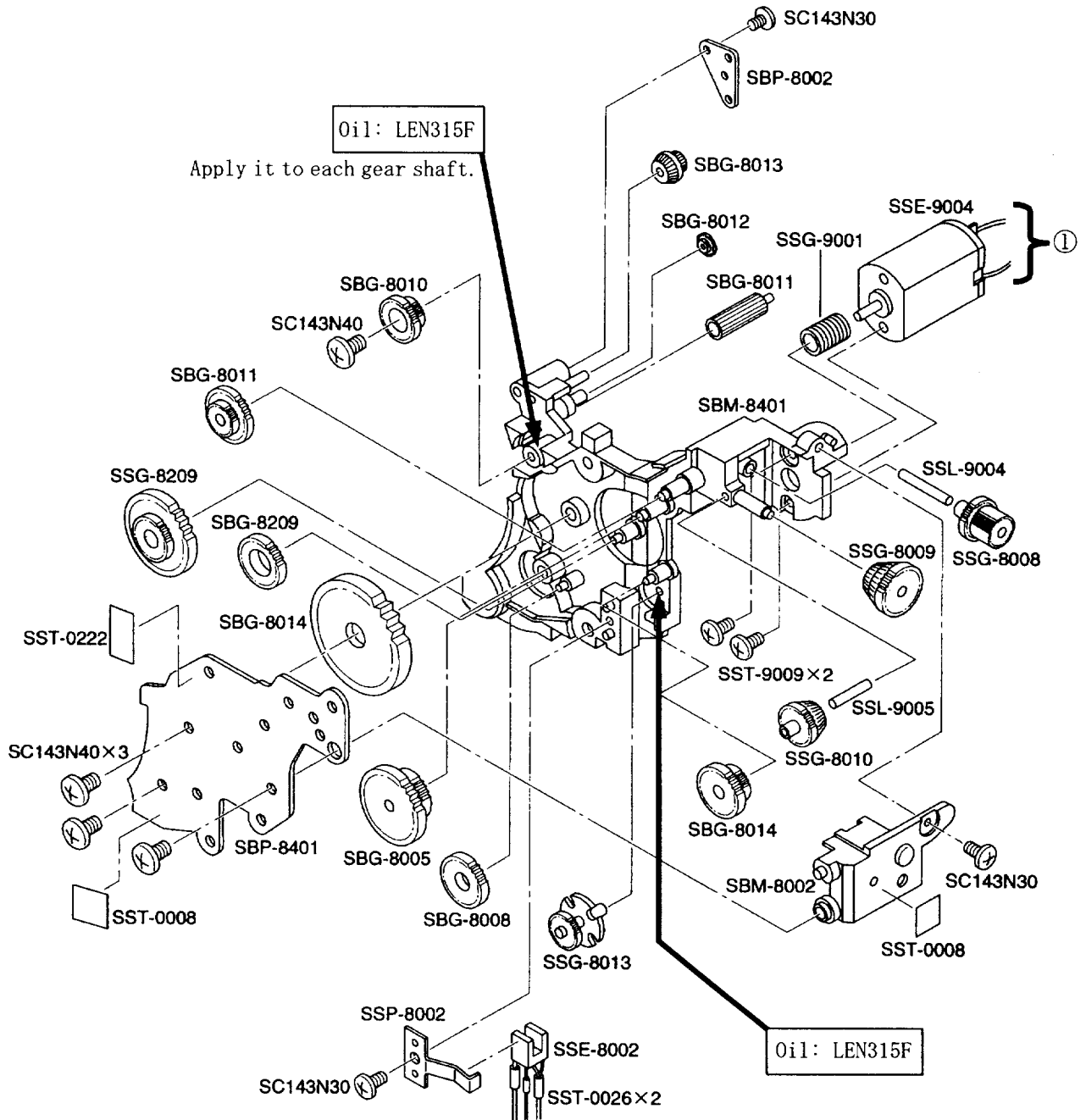

Film advance mechanism unit installation

- Mount the film advance mechanism unit 1 to the bottom of the body with the five screws 2 and one screw 3.

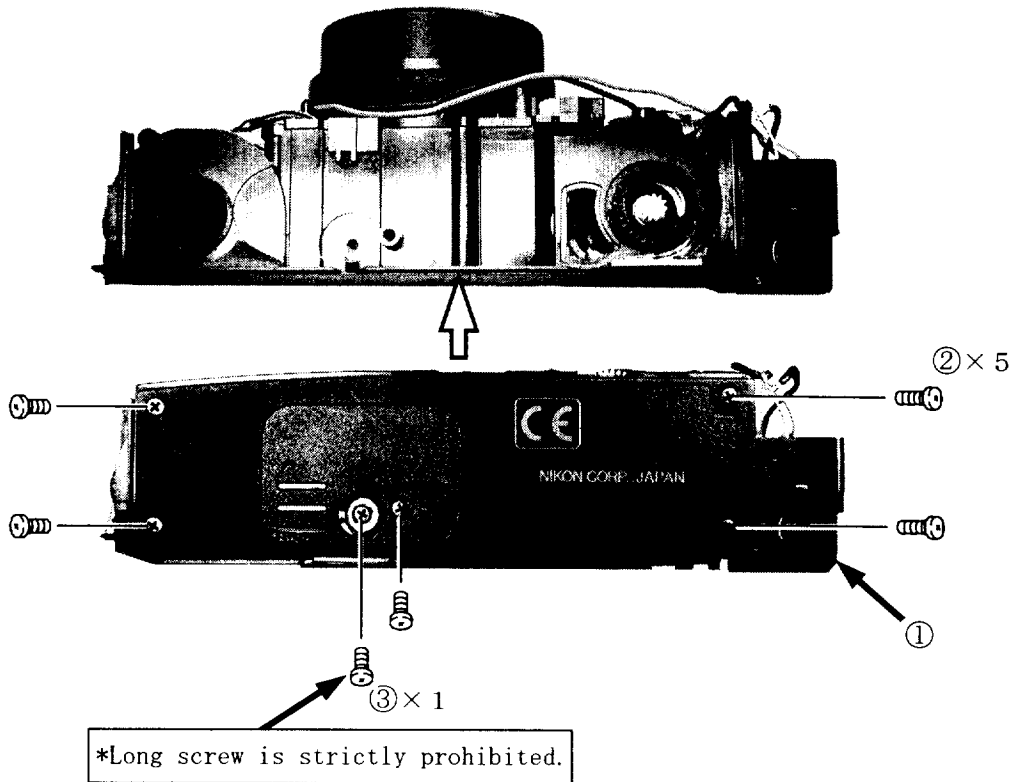

Lens barrel unit installation

- Mount the lens barrel unit 1 and tighten the four screws 2.

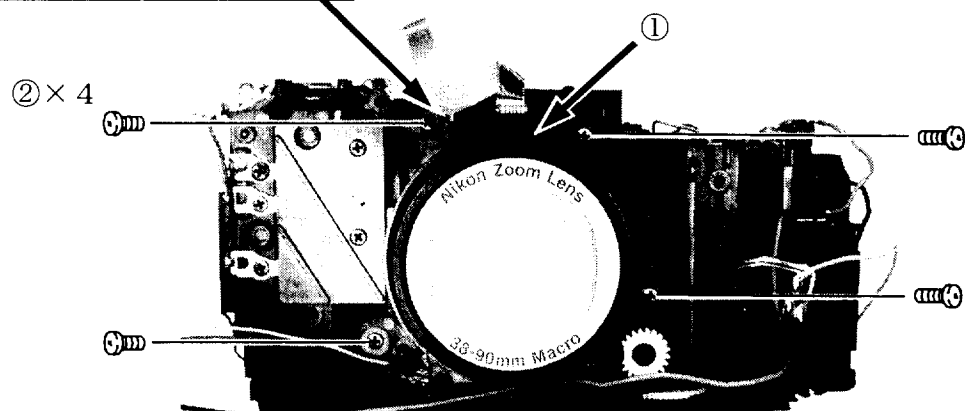
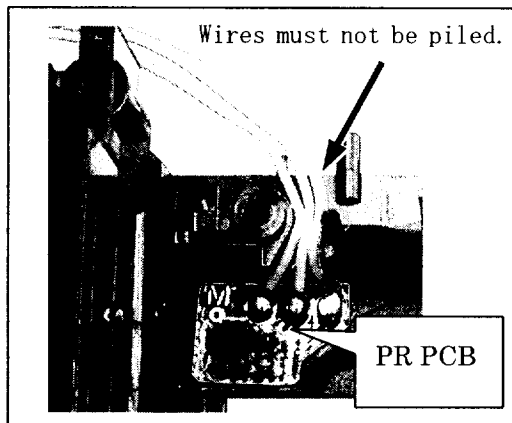

Zoom mechanism unit installation

- Put the zoom mechanism unit 1 into the groove of the body to mount it and tighten the two screws 2.

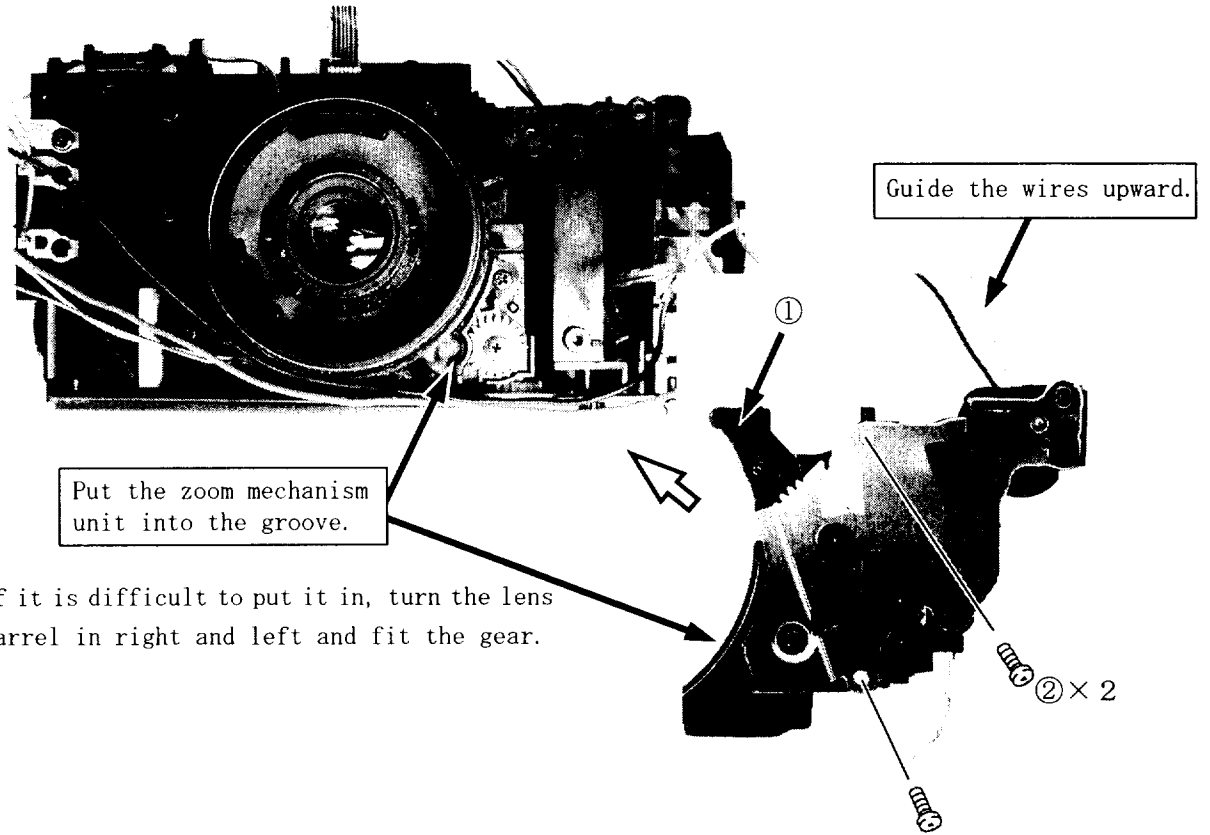

If it is difficult to put it in, turn the lens barrel in right and left and fit the gear.

Speed light unit installation

- Solder the red wire of the battery terminal and black wire of the terminal SP 2 to the speed light PCB 1.

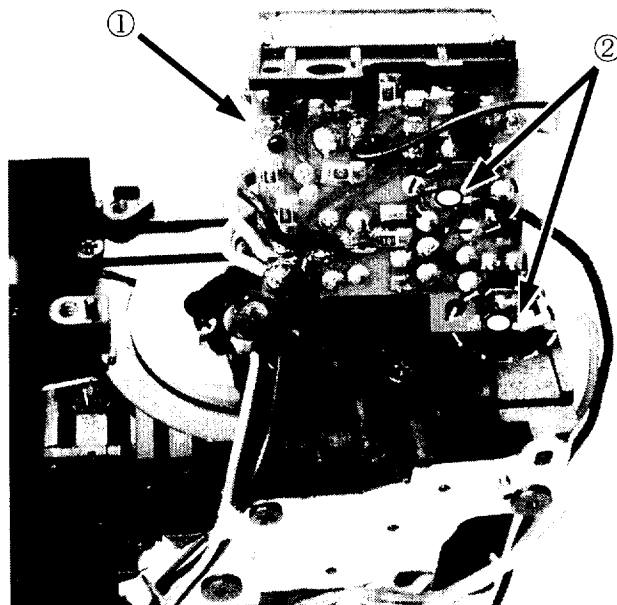

- Mount the speed light PCB 3 and tighten the two screws 4.
- House the main condenser 5 into the body and fix it with tape 6.

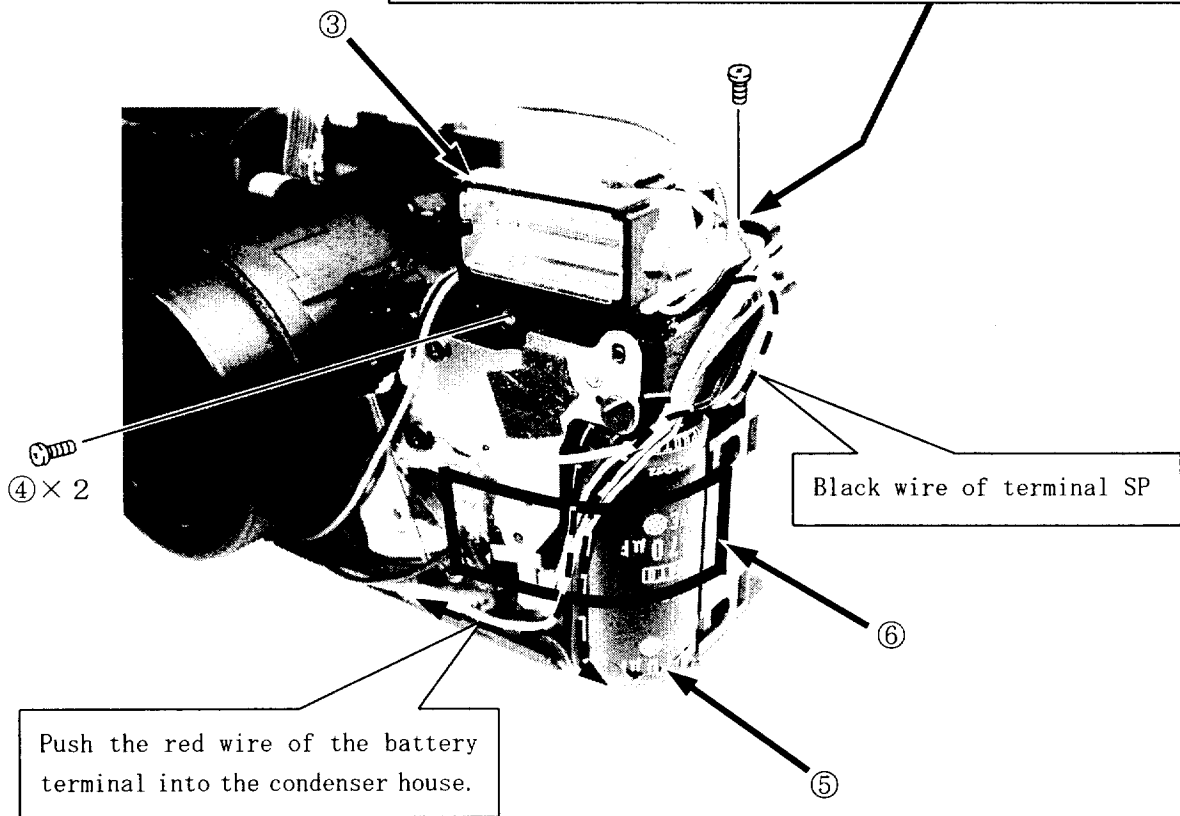
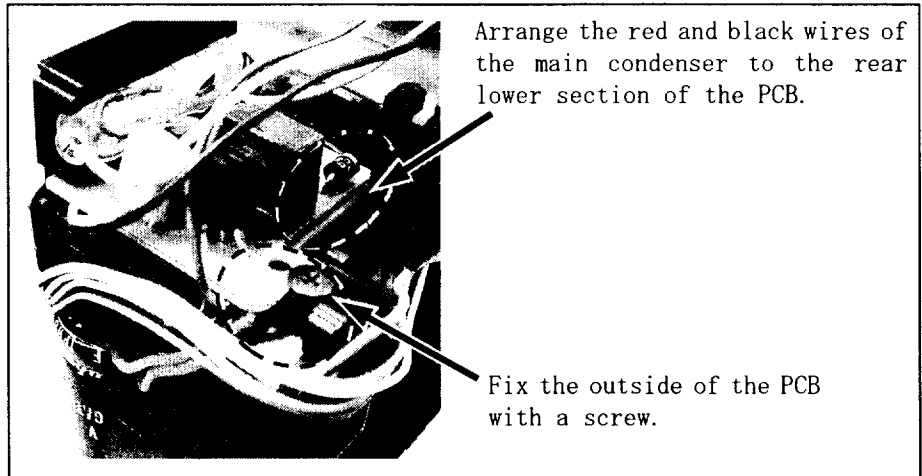

Finder unit installation

- Mount the finder unit 1 to the body and tighten the three screws 2.

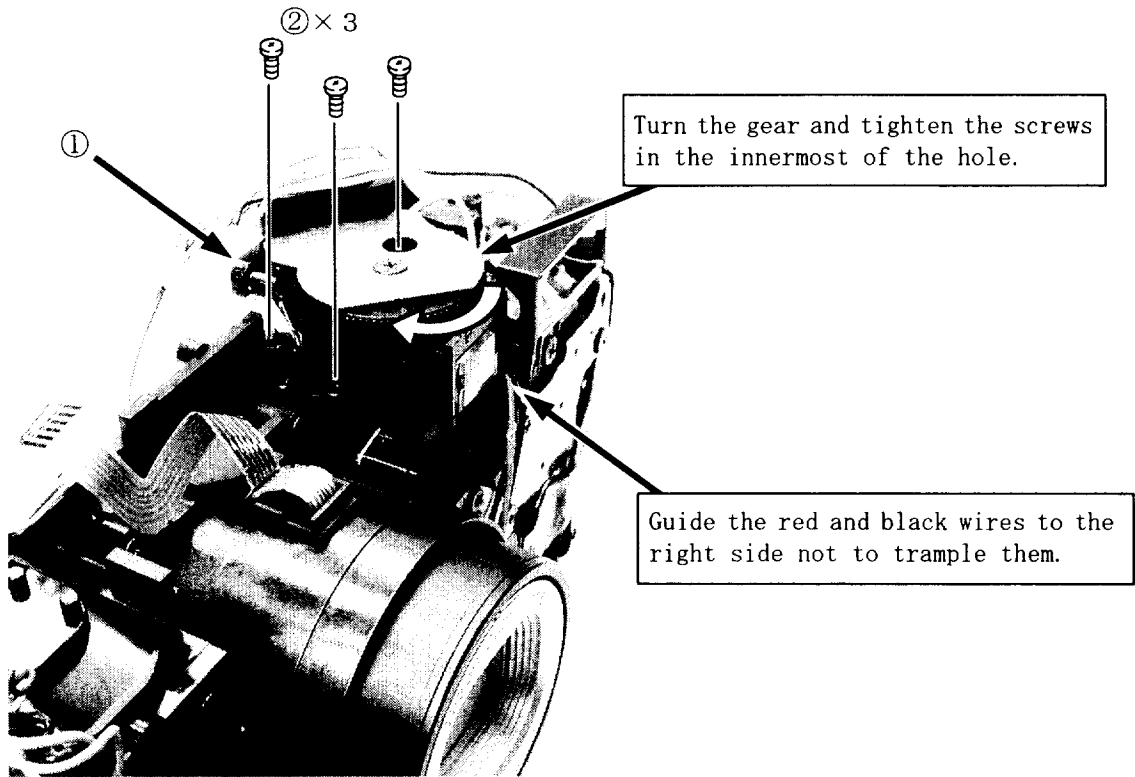

AF unit installation

- Mount the AF unit 1 to the body and assemble the FPC retainer 2.

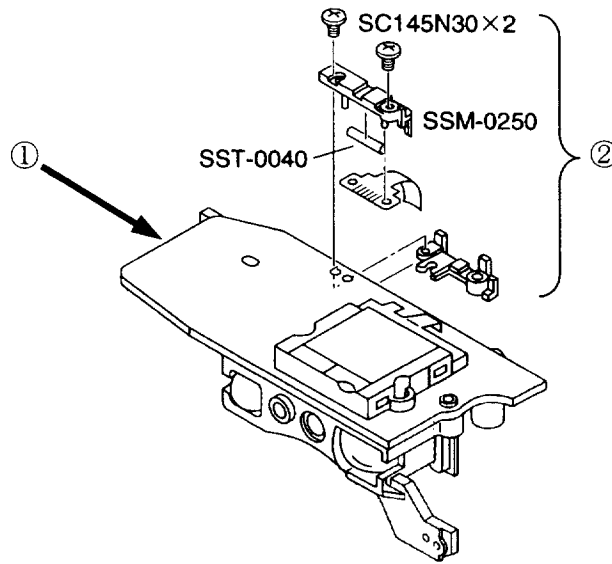

- Mount the AF unit 1 to the body and tighten the two screws 3.

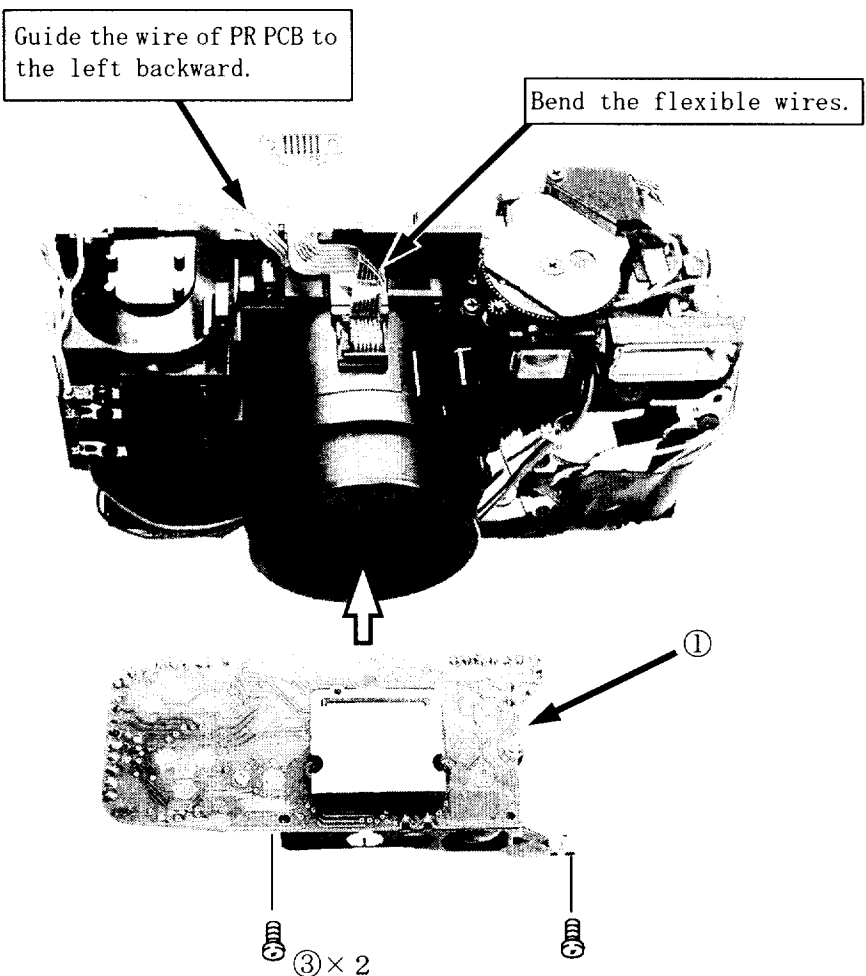

- Solder the wires.
Refer to the wiring diagrams of page E1 and E2.

Wire processing

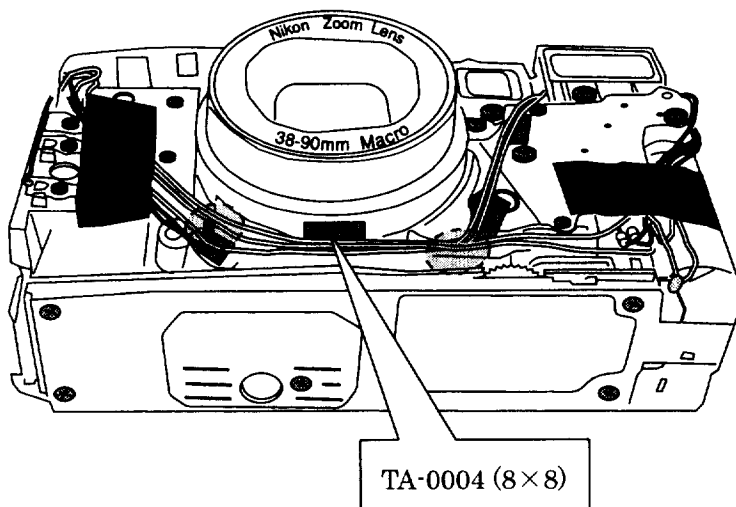
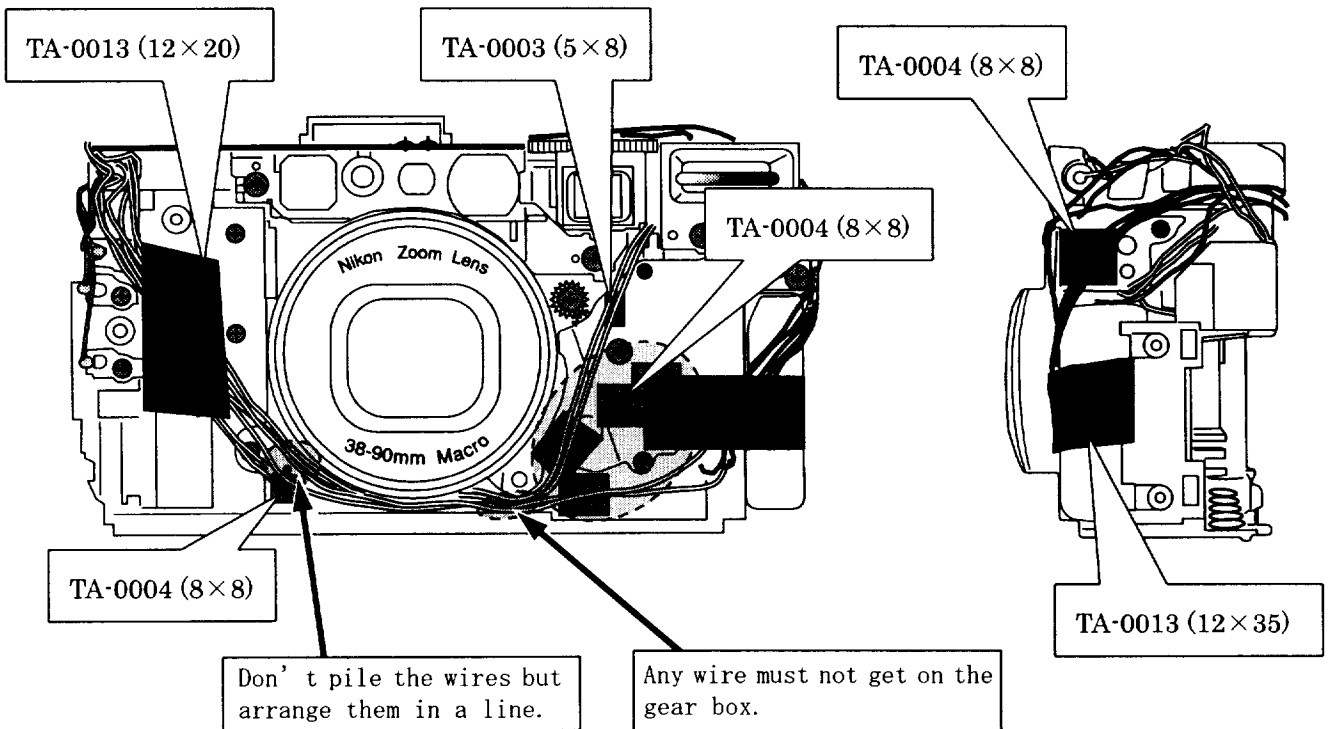
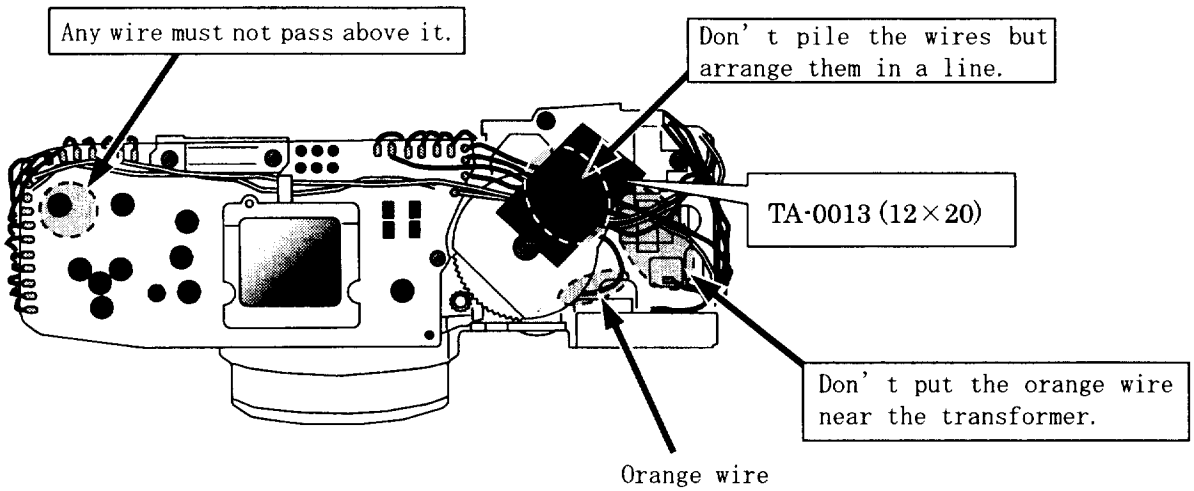

Finder positioning

- Set the lens barrel to the W end.
- Set the groove 1 of the gear #127 1mm leftward from the line 2 connecting the gear #127 with #128.
- Insert the gear #117 and tighten the screw 3.

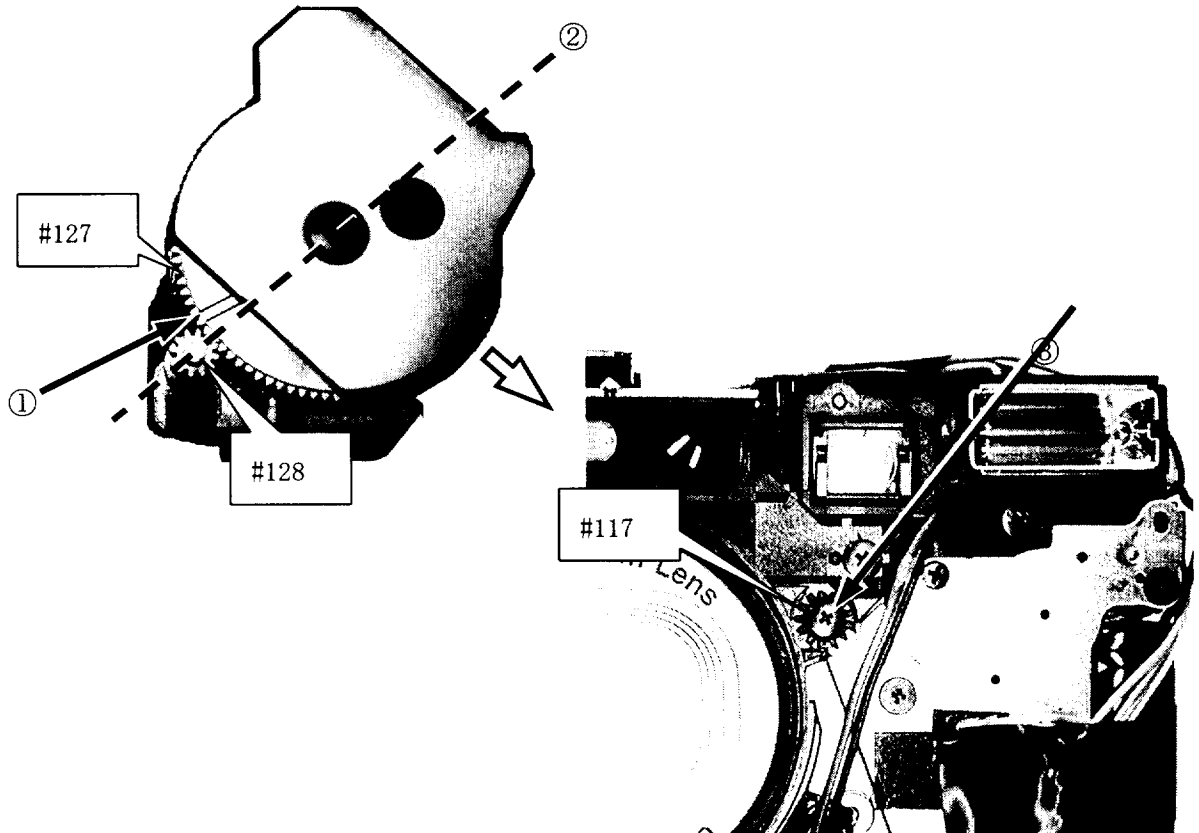

Front cover installation

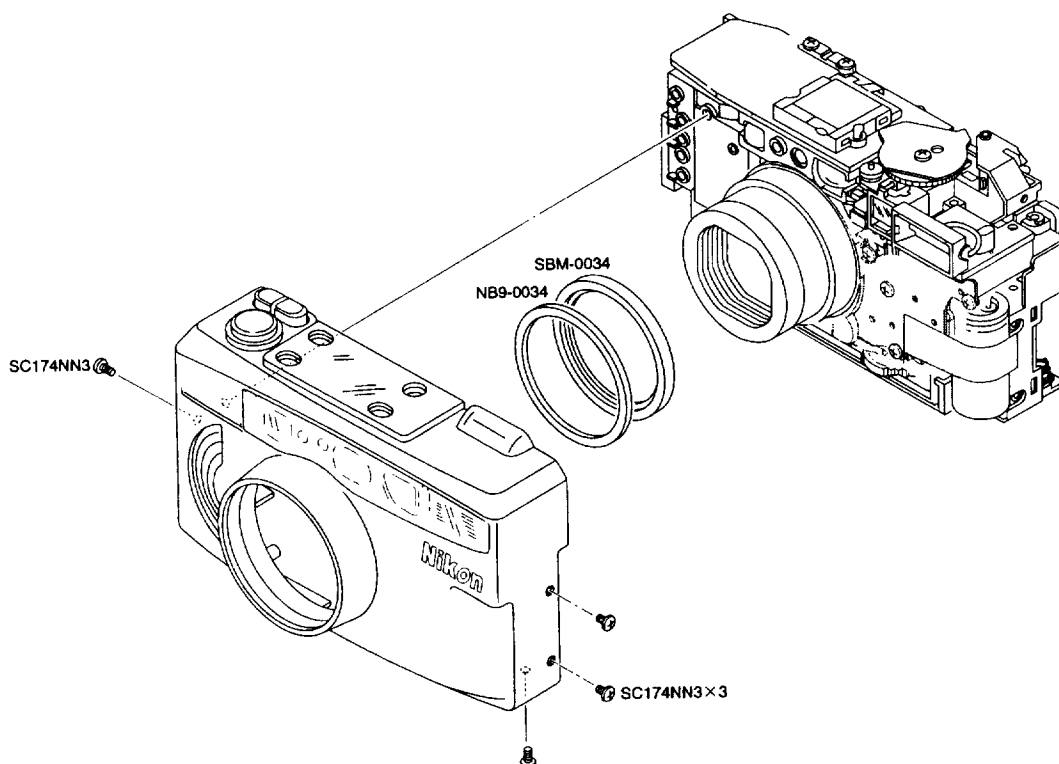

Back

focus

inspection and adjustment

● Inspection and adjustment with test mode

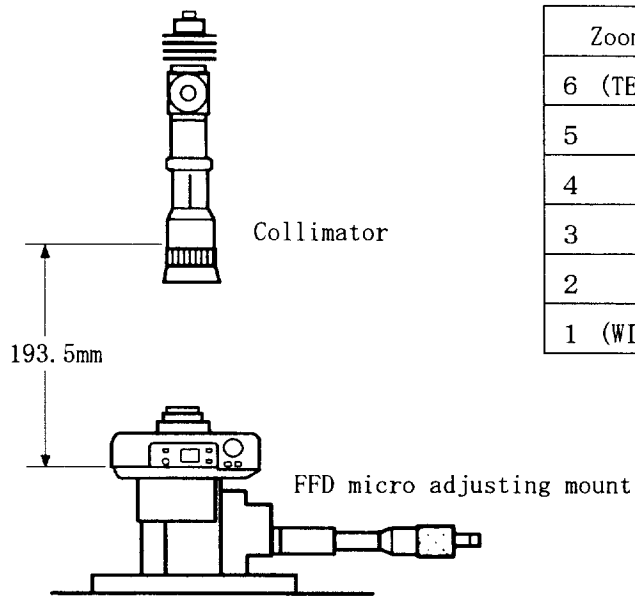

Zoom position	Standard of adjustment
6 (TELE side)	- 3 0 0 ~ + 3 0 0 μ m
5	- 3 0 0 ~ + 3 0 0 μ m
4	- 3 0 0 ~ + 3 0 0 μ m
3	- 3 0 0 ~ + 3 0 0 μ m
2	- 3 0 0 ~ + 3 0 0 μ m
1 (WIDE side)	- 2 0 0 ~ + 2 0 0 μ m

1. Preparation

- 1) Turn the objective lens of the collimator (J19019) and set the scale to - 2.7mm (-27 division).
- 2) Set "0" for the display of the FFD adjusting micro mount (J15327).

2. Set the manual test mode for the camera.

- 1) Open the camera back and set the camera back switch to "camera back closed".
- 2) Set the main switch to "ON" and move the lens barrel forward to the W end.
- 3) As keeping the speed light mode switch "ON", set the film rewind switch to "ON" to display "LS" on LCD.
- 4) Carry out release and set to "valve".

3. Start inspection.

- 1) Set a camera on the micro mount.
- 2) Turn the spindle of the FFD adjusting micro mount (J15327), read the value where the collimator (J19019) is in focus and make sure that the read value is within standard.
- 3) Operate the zoom switch and, at each zoom position, perform inspection in the same way.
- 4) If the values are within standard, carry out the ending operation of Item 4. If they are out of standard, proceed to Item 5 and carry out adjustment.

4. Ending operation

- 1) Operate the main switch and exit from the test mode.
- 2) Set the camera back switch to "open" and then close the camera back.

5. Perform adjustment.

- 1) Turn the spindle of the micro mount and set to "0 μ m".
- 2) Set the lens barrel to the T end.
- 3) Carry out release to set "valve" and turn the front lens group to be in focus.

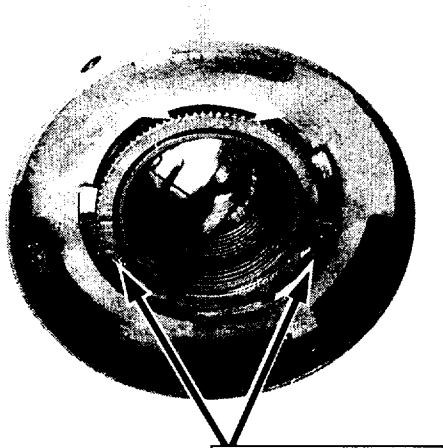

Adhesive: 1401B

- 4) Set the lens barrel to the W end.
- 5) Under the bulb open condition, turn the spindle of the micro mount to be in focus.
- 6) Repeat 2)~5) till the T end and W end are in focus.
- 7) Turn and shift the rear lens group by the value of the micro mount adjusted at the W end.

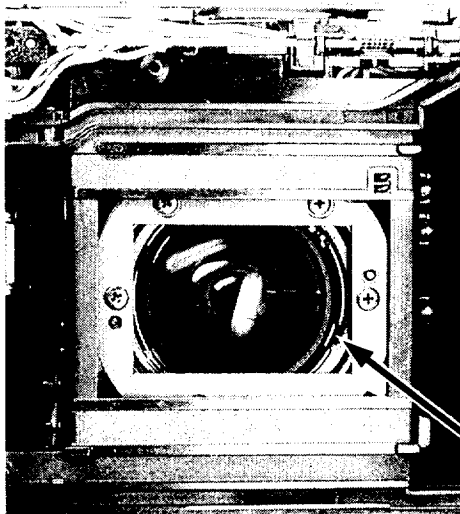

1 turn of the rear lens group is equivalent to 500 μ m.

Turn it counterclockwise for negative value.

Turn it clockwise for positive value.

Adhesive: 1401B

- 8) Turn the spindle of the micro mount to set to "0 μ m".
- 9) Make sure that focus is correct at the W end under the valve open condition.
- 10) After adjustment, apply adhesive to the front and rear lens groups to fix them.

● Inspection and adjustment with personal computer

1. Connect a camera to a personal computer.

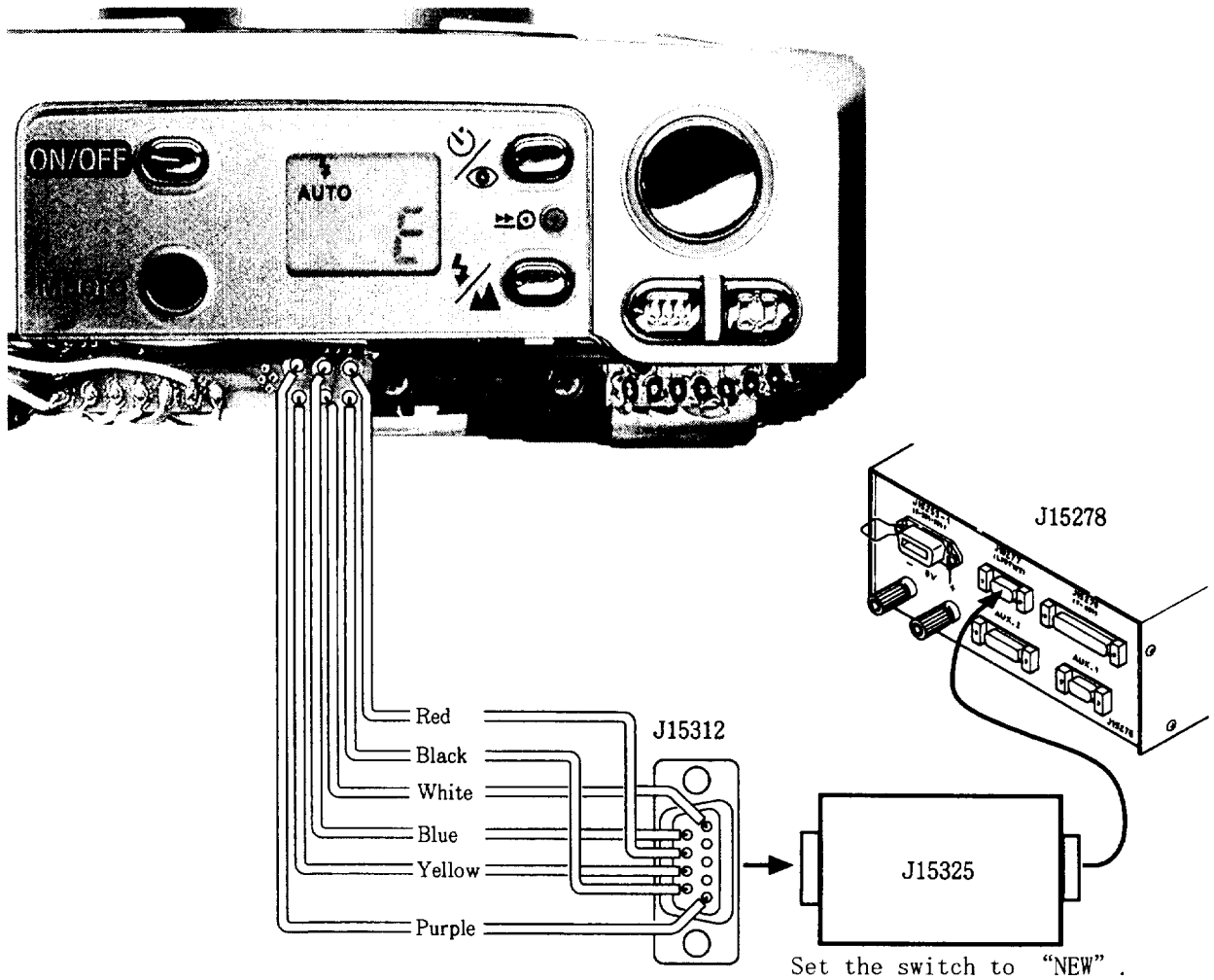

2. Start the inspection/adjustment software.

- Select the item of back focus adjustment in the main menu.
- Carry out inspection and adjustment according to the display on the personal computer.
- The contents of inspection and adjustment are the same as "Inspection and adjustment with test mode".

AE inspection

● Inspection and adjustment with personal computer

- 1) Connect a camera to a personal computer.
 - 2) Set the camera onto a shutter tester.
 - 3) Start the inspection/adjustment software and execute AE inspection.
- Carry out inspection according to the display on the personal computer. If a value is out of standard, replace the AF unit.

Standard: -1.0 ~ +2.0EV

AF inspection and adjustment

● Inspection and adjustment with personal computer

- 1) Connect a camera to a personal computer.
 - 2) Let the camera face a standard reflex paper (18%).
 - 3) Start the inspection/adjustment software and execute AF inspection and adjustment.
- Carry out inspection and adjustment according to the display on the personal computer.

Standard:

Distance (m)	Step
3. 0 3 3 5	6 ~ 7
2. 3 8 0 1	8 ~ 9
1. 8 1 0 7	1 1 ~ 1 2
1. 3 1 5 5	1 6 ~ 1 7
0. 9 9 0 9	2 2 ~ 2 3
0. 7 0 0 0	2 9 ~ 3 0

● Inspection with test mode

·Set the manual test mode for the camera.

- 1) Set the main switch to "ON" .
- 2) As keeping the speed light mode switch "ON" , set the film rewind switch to "ON" and red eye/self switch to "ON" to display AF on LCD.
- 3) Let the camera face a standard reflex paper (18%), lightly press the release button at the Specified distance and check the step number displayed on LCD.
- 4) When you hope to release the test mode, set the main switch to "OFF" .

Camera back·Side cover installation

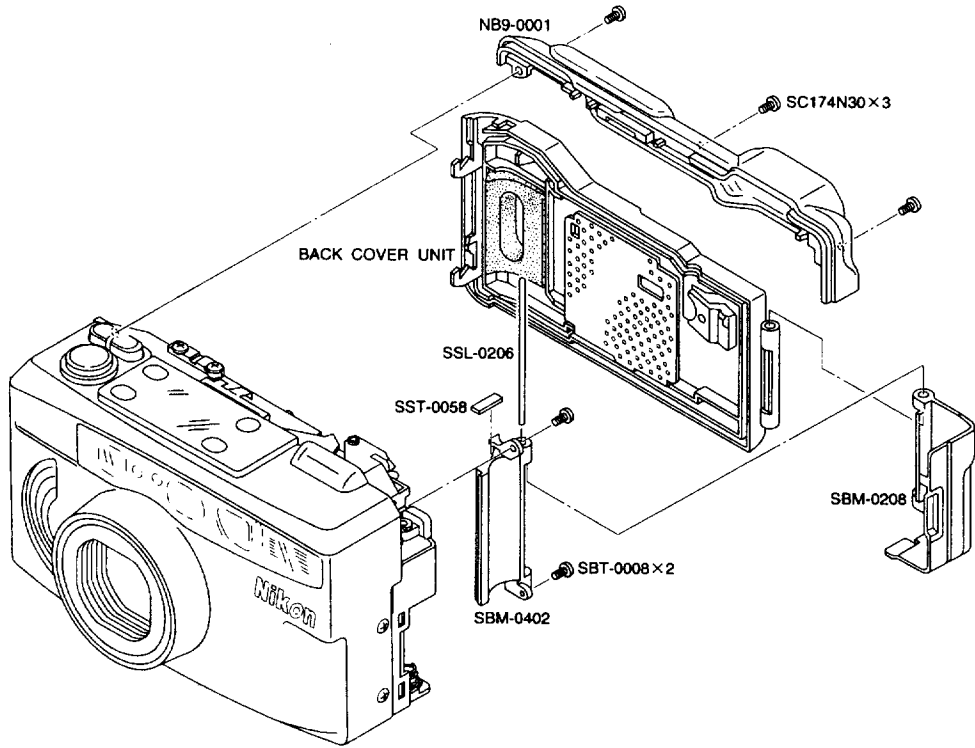

Barrier installation

● Move the lens forward, mount the barrier and tighten the two screws.

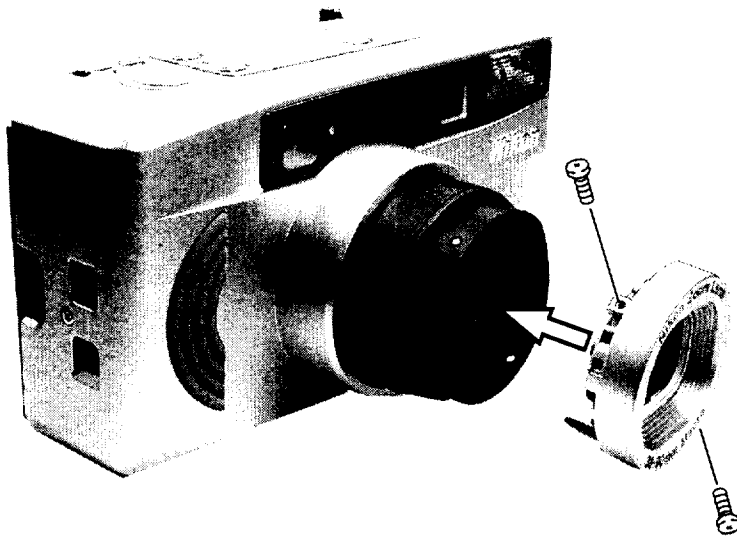

ELECTRIC CIRCUIT

WIRING FIGURE (Normal model)	E 1
WIRING FIGURE (QD model)	E 2
WIRING FIGURE (Date module)	E 3
CIRCUIT DIAGRAM (Normal model)	E 4
CIRCUIT DIAGRAM (QD model)	E 5

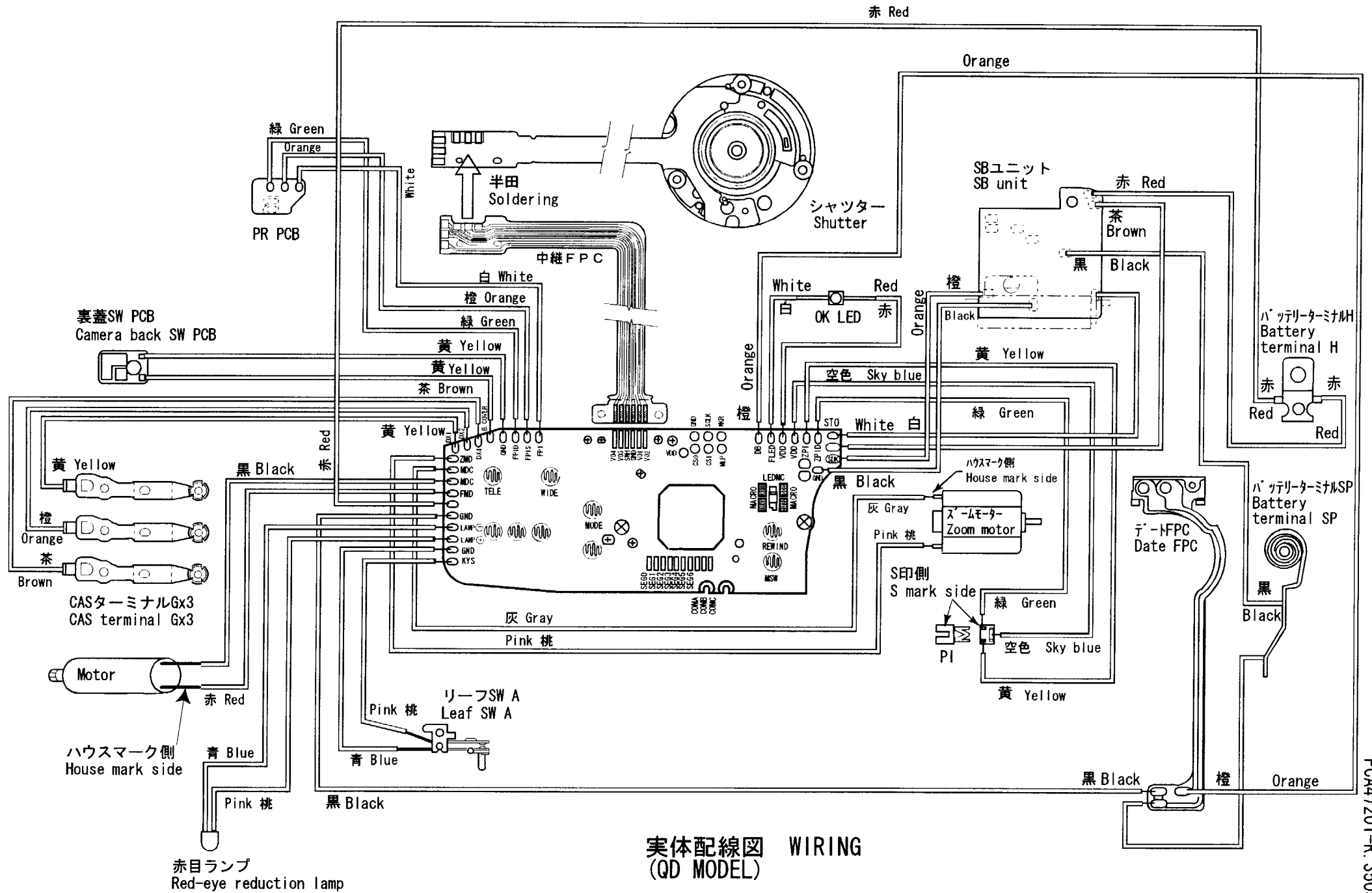

実体配線図 WIRING

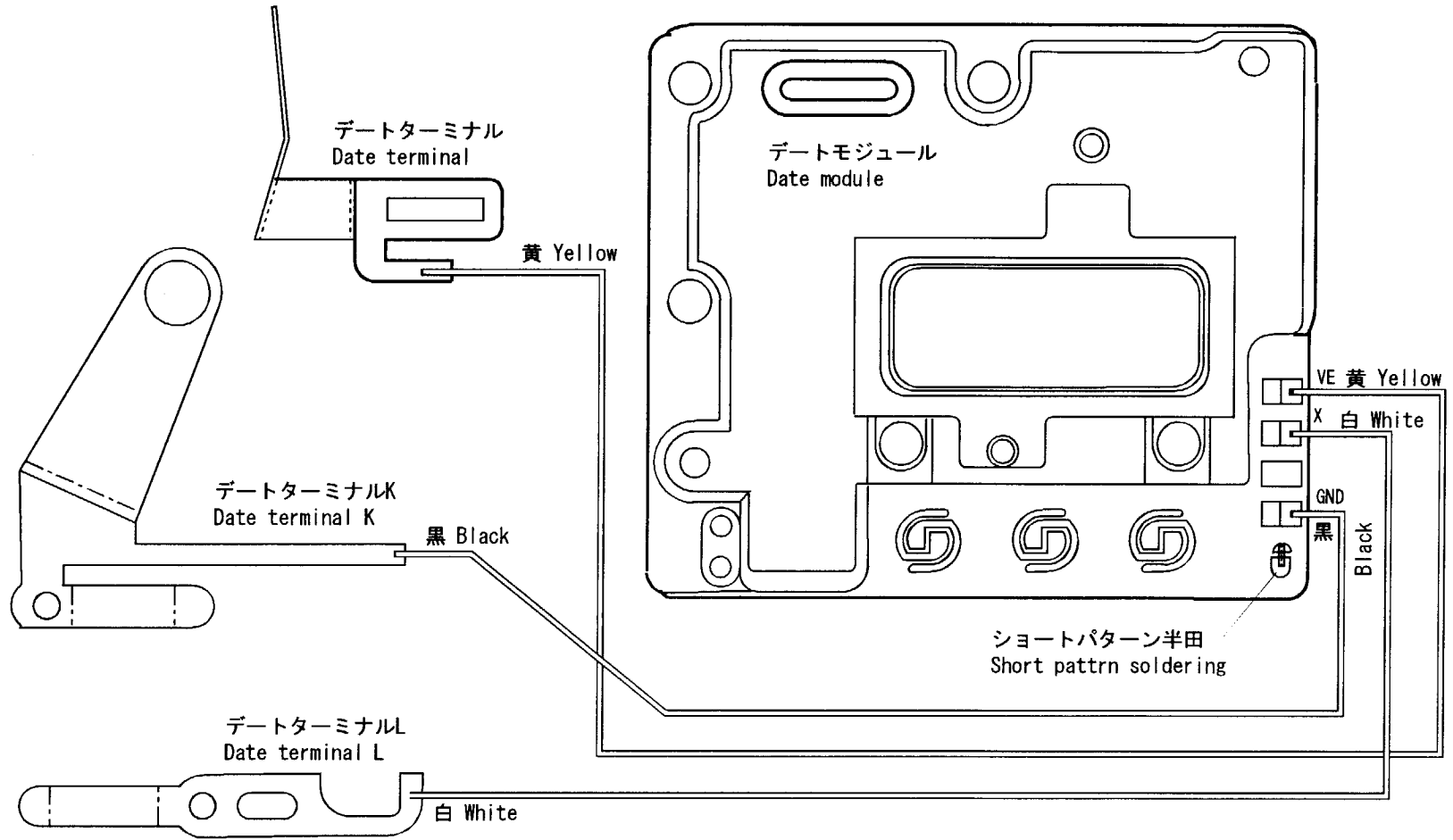

回路図 CIRCUIT DIAGRAM (NORMAL MODEL)

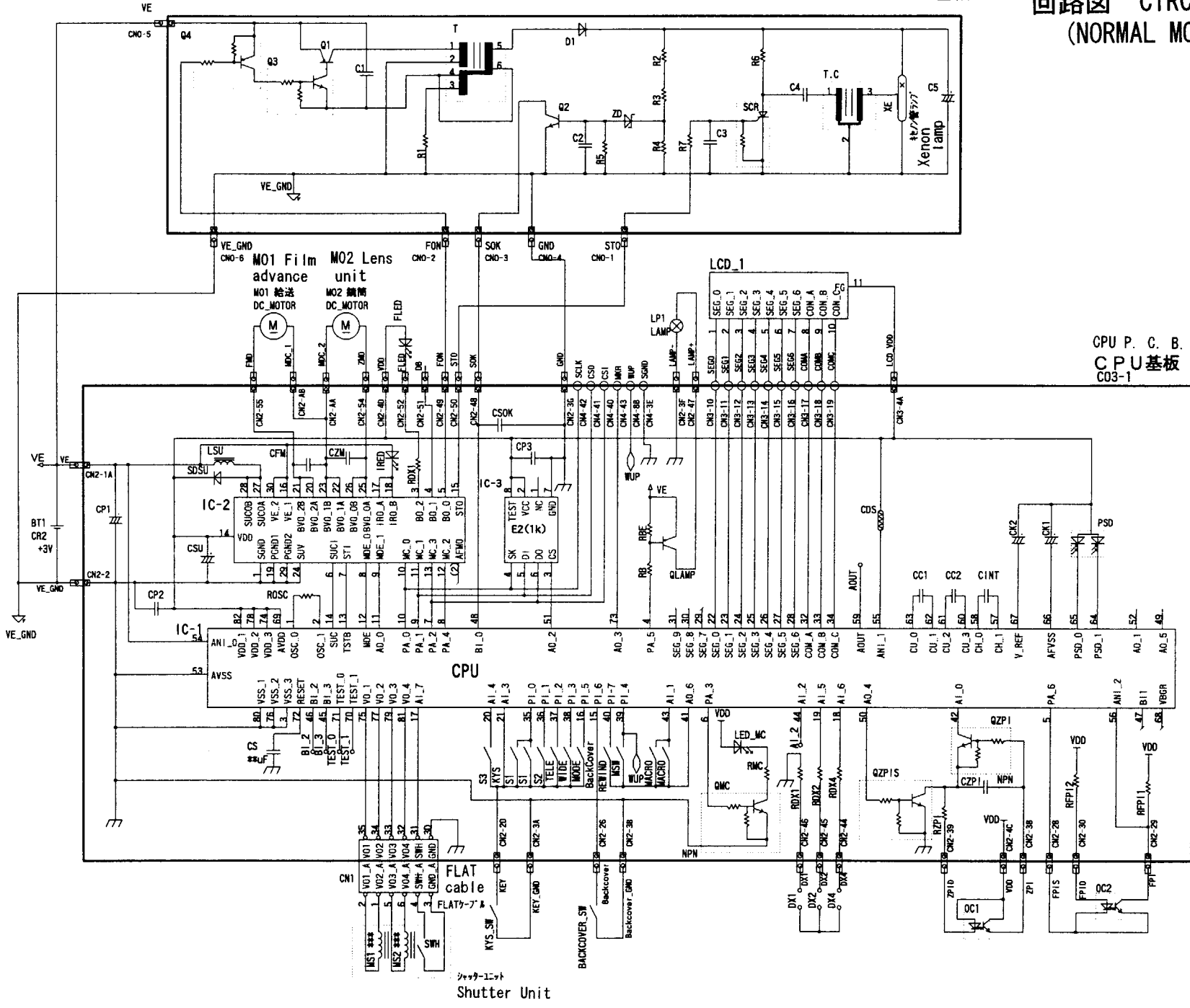

GPU P. C. B. CPU 基板 CO3-1

シャッターユニット Shutter Unit

回路図 CIRCUIT DIAGRAM (QD MODEL)

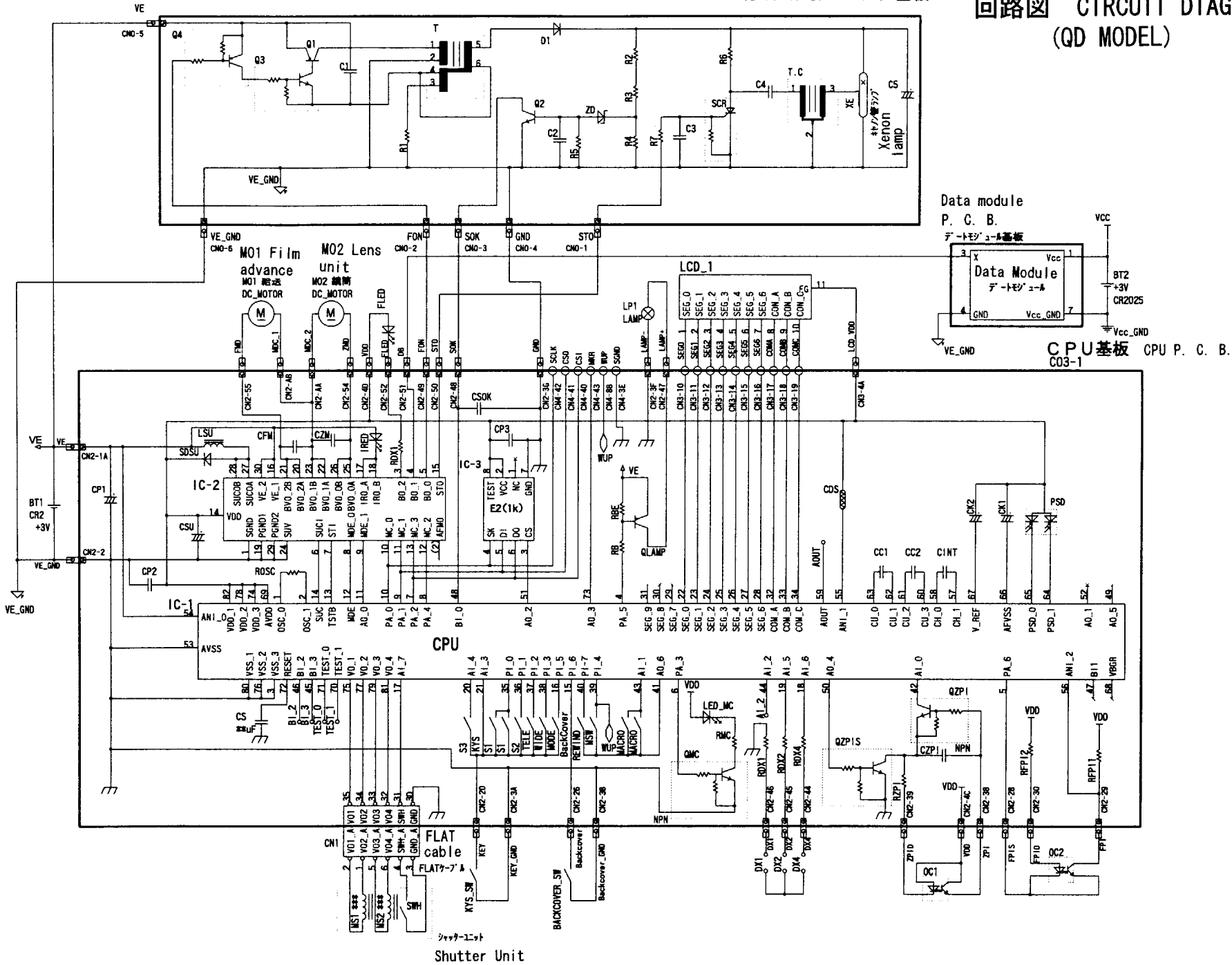

INSPECTION STANDARD AND TOOLS

[1] Inspection standard R 1
[2] Tools T 1

[1] Standard of inspection

	Item	Standard of judgment	Method and tools
Photography function	Photography lens	·Focal length W: $f=39.32\text{mm}\pm 5\%$ T: $f=39.32\text{mm}\pm 5\%$ Check the above under the valve condition.	
	Photography resolution Fixed point photography equivalent to 40f	·W Center: 29.90 dots/mm or more Periphery: 12.00 dots/mm or more Brightness of chart surface: LV9 Speed light mode: Flash prohibition Photography distance From the front of lens barrel at W: 1.56m (1.62m from film surface) ·M3 Center: 25.00 dots/mm or more Periphery: 11.00 dots/mm or more From the front of lens barrel at M3: 2.76m (2.84m from film surface) ·T Center: 20.30 dots/mm or more Periphery: 10.20 dots/mm or more From the front of lens barrel at T: 3.17m (3.26m from film surface) (0.35d: Image surface 15.1mm/5 ring belts)	JC II chart (4mm pitch) Neopan SS Microscope
	Full aperture FNo	·W full aperture Fno. $=4.94\pm 5\%$ ·T full aperture Fno. $=10851\pm 5\%$ Obtain the full aperture Fno. by the actual measured focal length.	Projector
	Actual photography performance	·There must be no harmful shading on a picture. Internal reflection, ghost and flare must not hinder practical use. Check by actual photography print.	Fuji SG-100
	Pheripheral light intensity	·Pheriphery light intensity must not be extremely decreased. 15% or more at 0.5d Check by actual sky photography.	Fuji SG-100
	Color repeatability	·Color repeatability must be good. Check by actual photography print.	Fuji SG-100
	Distortion	·Distortion must not be noticeable. Take a picture of a linear object at W/T.	Fuji SG-100
	CCI	·CCI must be within the ISO recommended value. Perform measurement at TELE.	Spectral photometer

	Eccentric dimness	·Eccentric dimness must not be noticeable. Check by actual photography print.	Fuji SG-100
AF performance	AF focusing function	·W/M/T There must be 33 frames or more and each of them must be 20.0 dots/mm or more. There must be 3 frames or more and each of them must be 8.0 dots/mm or less. Distance from the inner rail surface to the object 0.8~3.5m: You must take a picture every 10cm. 3.8m/4.0~7.0m: You must take a picture every 50cm till total 36 pictures are taken. Brightness of chart surface: LV9 Speed light mode: Flash prohibition	Neopan SS Oxford gray No. 22 Wavelength: 880nm Reflectance: 35±5% Powersupply (1)
	Infinity photography	·There must be no extreme defocus. 14 dots/mm or more in AF infinity 20 dots/mm or more in forced infinity Take a picture of distant view in the forced infinity mode and AUTO. In T/M/W, when the external light has the same brightness as the speed light luminance, cover the camera metering unit, set aperture to "full" and take a picture.	Fuji SG-100
	Beam irradiation position	·The center of AF beam must be within the specified chart range. Let the camera face the specified chart from 1m distance and press the release button lightly.	Infrared rays camera/Monitor Target mark Sheet Camera fixing jig and tool
	AF distance measurement accuracy	·There must be no step deviation. (±1 step in $B_v \leq 7$) Check the distance measurement length and AF step in a special mode.	
	AF no-signal control	·The camera must be positioned at AF infinity. Shield the light emitting unit, let the light source "A" face the light receiving unit and check at $B_v \leq 7$.	

Lens barrel unit	Lens barrel operation	<ul style="list-style-type: none"> ·The lens barrel must not operate by self-weight at each position. Set the zoom at each step, grasp and lift the lens barrel. Set the zoom at each step and put the camera on a ground with its lens barrel at the bottom. ·The lens barrel must move forward properly. Measure the forward moving quantity of the lens barrel at each step. 	Visual check
	Lens cover	<ul style="list-style-type: none"> ·The lens cover must be opened and closed smoothly. It must not be caught halfway. Press the main switch button, move the lens barrel from the push-in position to the W end position and then return it to the push-in position. 	Visual check
	Play of lens barrel	<ul style="list-style-type: none"> ·Twist thrust must be 0.3mm or less. Twist the end of lens barrel at T end. ·The end flapping must be 0.5mm or less. Add the flapping load, 100gf. 	Special gauge
Lens barrel unit	Eccentricity	<ul style="list-style-type: none"> ·The clearance between the lens barrel and front cover must be 1/2 or less of the difference between the maximum and minimum parts. Check the clearance between the lens barrel and front cover. 	Pin gauge
	Driving noise	<ul style="list-style-type: none"> ·It must be 60dB or less at average sound pressure. Abnormal noise must not occur during operation. Measure noise in 45° at a position 20cm away from the lens front surface. 	
	Lens barrel abnormal stop	<ul style="list-style-type: none"> ·There must be 400g or more in the upward position. Set the lens barrel upward and put a special gauge on it. 	Special gauge

Automatic exposure	AE accuracy	<p>·The camera must meet the following conditions in ISO100, 200, 400 and 800.</p> <p>·Unexposed photography must not occur.</p> <p>Application range A WIDE: $6 \leq Ev \leq 15.0$ TELE: $6 \leq Ev \leq 17.0$ Error: $+2.0 \sim -1.0Ev$ Difference: 1.5Ev Neighboring difference: Reverse must not occur every 1.5Ev.</p> <p>Application range B WIDE: $15.0 < Ev \leq 16.0$ TELE: $17.0 < Ev \leq 18.0$ Error: $+2.5 \sim -1.5Ev$ Difference: 2.0Ev Neighboring difference: Reverse must not occur every 2.0Ev.</p> <p>Error: Error of each measured value obtained by continuous 3 measuring operations Difference: Difference between the maximum and minimum values obtained by continuous 3 measuring operations Neighboring difference: Average value obtained by measuring the neighboring exposure values 3 times continuously</p>	AE tester Power supply(1)
	FM accuracy	<p>Application range A: $4.94 \leq F \leq 11.31$ Error: $+2.0 \sim -1.0Av$ Difference: 1.5Av Neighboring difference: Reverse must not occur every 1.5Av.</p> <p>Application range B: $11.31 \leq F \leq 16.00$ Error: $+2.3 \sim -1.3Av$ Difference: 1.8Av Neighboring difference: Reverse must not occur every 1.8Av.</p>	AE tester Power supply(1)
Speed light	Guide number	<p>·Gno.: $10 (ISO100 \cdot m) \pm 0.5Ev$</p> <p>·Point and line: Gno. 7.1 or more Measure the guide number at a position 1.97m away from the speed light whole surface. (From film surface: 2m)</p>	JC II flash Meter IV Power supply(1)
	Light division characteristics	<p>·At 28° in the right and left direction and 20° in the up and down direction, within $-1Ev$ against the image center</p>	JC II flash Meter IV Power supply(1)
	Recycling time	<p>·8 seconds or less Release occurs after 8 seconds since winding ended.</p>	Power supply(1) Stop watch
	Automatic flash change accuracy	<p>W: $Bv 10.125 \pm 1Ev$ T: $Bv 13.375 \pm 1Ev$</p>	AE tester
	Color temperature	<p>·$5800^\circ K \pm 300$ Measure the temperature at point and line flash.</p>	Minolta color Meter III F

	Red eye reduction accuracy	·Brightness should be approx. 10 LUX or more. Measure the brightness at a position 30cm away from the camera front finder cover in a dark room.	Minolta digital illuminometer T-1
Film advance	Film scratch	·The photographed picture must not have harmful scratch. Take pictures with two films and observe the pictures from beginning to end.	Fuji Neopan SS Power supply(1)
	Film damage	·Film must not have damage which affects adversely the film advance and the photographed picture. Check negative film for damage.	Fuji Neopan SS Power supply(1)
	Space between pictures	·Within 0.5~3.5mm in the specified picture number ·The specified number of pictures must be taken. Overlap of the last frame (out of the specified number) is allowable. Check the space between pictures with the negative film which has been used to the last frame at 36EX. Take pictures by 18 shots at T/W in the forced infinity mode.	Fuji Neopan SS Power supply(1) And (3) Visual check
	Picture size	· $24^{+0.8} \text{ } ^{-0.3} \text{mm} \times 36^{+0.8} \text{ } ^{-0.3} \text{mm}$ Check the picture size with negative film. Take pictures at W/T in the forced infinity mode.	Fuji Neopan SS Vernier calipers
	Picture position	·Up and down direction: 0.2mm or more between the picture and perforation There must be no extreme inclination. Check the picture position with the negative film which has been used in T/W photography. After one frame of picture has been photographed, add vibration of reliability, take a picture again and check its position.	Fuji Neopan SS Power supply(1) And (3)
	QD copy center position	· $X=11.5\text{mm} Y=-9\text{mm}$ When all the digits are copied, the bottom of characters must be 2.7 ± 0.5 from the outline of the negative film and their right side must be 4.5 ± 0.5 . Check the position with the negative film which has been used at W end and M/T from the front of lens barrel.	Fuji Neopan SS Inspection jig and tool
	Time of each operation	·One frame advance: Within 1 second Measure the time after release. ·36EX rewinding: Within 40 seconds Start measurement the moment the last frame is released.	Fuji ISO100 Power supply(1) Stop watch

Finder	Finder	<p>·The field of viewfinder must be 80% or more and less than 100% against the picture image in vertical and horizontal directions.</p> <p>Check the field of viewfinder with the negative film which has been used at W end 2.94m and T end 2.91m (W/T 3m from film surface).</p> <p>·The visual field must not be inclined extremely.</p> <p>·Parallax: It must be within the picture to be taken.</p> <p>·In near distance photography, the whole visual field must be taken at the top, right and left.</p> <p>The bottom must not be protruded extremely.</p> <p>At T 0.61m (0.7m from F surface) and macro 0.24m (0.7m from F surface), take a picture according to the "d" near distance compensation frame.</p>	Fuji Neopan SS
		<p>·Diopter: -0.7 diopter +0.5/-1</p> <p>Measure T/W in a distant view of 30m or more with a diopter telescope.</p> <p>·Diopter difference between image and frame: 0.7 diopter</p> <p>Diopter difference of T/W: Within 1.0 diopter</p> <p>Perform measurement with WIDE as standard.</p> <p>·Magnification</p> <p>W $0.336 \pm 15\%$ T: $0.686 \pm 15\%$</p> <p>By using a diopter telescope, measure the distance between two points of 50m or more away from each other when a camera is used and when a camera is not used.</p> <p>·The AF beam center position must be within the target mark.</p> <p>In a 3m distance, check the misalignment for the AF zone and AF beam center of the finder.</p> <p>·There must be no optical axis misalignment.</p> <p>In a 3m distance, mark the center of the target mark at WIDE. At TELE, the center of this mark must not deviate from the target mark.</p>	Diopter telescope Visual check
Electric current consumption	SI ON condition	60mA or less Measure the electric current when OK LED lights after BC.	Ammeter/Power supply (1) Use the power supply (2) to measure the operating time.
	AE series	380mA or less Measure the electric current at luminance without speed light flash.	
	Self-timer operation	150mA or less Measure the electric current when self-timer is operating.	

	Film winding	420mA or less Measure the electric current when one frame is being advanced during FFS.	
	Film rewinding	460mA or less Measure the electric current when film is being rewound.	
	Auto. power OFF	10 μ A or less Measure the electric current under the auto. power OFF condition.	
	Main switch ON	10 μ A or less (40mA or less at the last stage of speed light pressurization) Measure the electric current after 1 minute since the main switch was turned on.	
	Zoom Zo \rightarrow W	300mA or less/operating time: 1 second or less Measure the electric current as pressing the zoom button. TYP of electric current consumption is approx. 300mA.	
	Zoom W \rightarrow T	300mA or less/operating time: 3 seconds or less	
	Zoom T \rightarrow W	300mA or less/operating time: 3 seconds or less	
	Zoom W \rightarrow Zo	300mA or less/operating time: 1 second or less	
BC voltage	BC warning voltage	<ul style="list-style-type: none"> ·At 2.45~2.70V, the battery mark must blink and release must be possible. Other displayed items must be normal except the battery mark. ·At 2.40\pm0.1V, the battery mark must blink and release must be possible. This voltage value is standard in a camera and actual measurement is not possible. After checking the battery mark on LCD, perform release. 	Power supply(3) Visual check
	BC lock voltage	<ul style="list-style-type: none"> ·At 2.25~2.50V, the battery mark must blink and release must be impossible. Others must be turned off except the battery mark. ·At 2.20\pm0.1V, the battery mark must blink and release must be impossible. This voltage value is standard in a camera and actual measurement is not possible. ·The BC warning voltage and BC lock voltage must not be reversed in a same camera. (Electric potential difference: 0.1V or more) ·At 2.10\pm0.1V, LCD is turned off. After checking the battery mark on LCD, perform release. 	Power supply(3) Visual check

[2] TOOLS

1. Major general tools and testers

☆ : New tool

Tool No.	Name	Specifications
J19019	Collimator	24LT-2DTS f=193.5mm
J15291	Micro stand for adjusting FFD	
J19036 J19042	Multi shutter tester	EF511N, EF-8000
J18190	Standard reflect paper	OXFORD GRAY NO.22
J15312	Connection tool	
J15325	Interface box for LS CAMERA	
☆ J18315A	Adjustment software	NEC 5 inch
☆ J18315B	Adjustment software	NEC 3.5 inch
☆ J18315C	Adjustment software	IBM 5 inch
☆ J18315D	Adjustment software	IBM 3.5 inch