



# ***Nikon* PRONEA 6i**

INSTRUCTION MANUAL

# CONTENTS

---

<b>FOREWORD</b> .....	<b>4-5</b>	<b>GENERAL FUNCTIONS</b> .....	<b>37-74</b>
<b>NOMENCLATURE</b> .....	<b>6-12</b>	<b>ADVANCED MODE AND BASIC MODE</b> .....	<b>38-39</b>
LCD panel indication .....	8-9	<b>VARI-PROGRAM</b> .....	<b>40-45</b>
Viewfinder indication .....	.10	WHAT IS VARI-PROGRAM? .....	.40
Buttons and Command dials .....	11-1 2	SETTING VARI-PROGRAM .....	.41
<b>BEFORE SHOOTING</b> .....	<b>13-31</b>	VARI-PROGRAM SELECTION GUIDE .....	<b>42-43</b>
<b>INSTALLING BATTERY FOR DATE/TIME BACKUP</b> .....	<b>14-16</b>	OPERATION IN VARI-PROGRAM .....	<b>44-45</b>
<b>CHECKING BATTERY POWER FOR DATE/ TIME BACKUP</b> .....	<b>17</b>	<b>EXPOSURE MODE</b> .....	<b>46-59</b>
Replacing battery for date/time backup .....	.18	ABOUT EXPOSURE .....	46-48
<b>SETTING DATE/TIME</b> .....	<b>19-21</b>	OPERATION IN AUTO-MULTI PROGRAM .....	49-50
<b>MOUNTING LENS</b> .....	<b>22-24</b>	FLEXIBLE PROGRAM .....	51-52
<b>INSTALLING BATTERIES</b> .....	<b>25</b>	OPERATION IN SHUTTER-PRIORITY AUTO EXPOSURE MODE .....	53-54
<b>CHECKING BATTERY POWER</b> .....	<b>26</b>	OPERATION IN APERTURE-PRIORITY AUTO EXPOSURE MODE .....	55-56
<b>HOLDING CAMERA/PRESSING SHUTTER RELEASE BUTTON</b> .....	<b>27</b>	OPERATION IN MANUAL EXPOSURE MODE .....	57-59
<b>INSTALLING FILM CARTRIDGE</b> .....	<b>28-31</b>	<b>METERING SYSTEM</b> .....	<b>60-62</b>
<b>BASIC OPERATION</b> .....	<b>32-36</b>	<b>AF MODE AND FOCUS AREA</b> .....	<b>63-71</b>
<b>BASIC SHOOTING</b> .....	<b>33-35</b>	SELECTING AF MODE AND FOCUS AREA .....	63-66
<b>AFTER SHOOTING</b> .....	<b>36</b>	SINGLE-SERVO AF OPERATION .....	67-68
		AUTOFOCUS WITH MAIN SUBJECT OFF-CENTER .....	69-7 0
		CONTINUOUS SERVO AF OPERATION .....	71
		<b>FILM ADVANCE MODE</b> .....	<b>72-73</b>
		<b>TWO-BUTTON RESET</b> .....	<b>74</b>

ADVANCED PHOTO SYSTEM FUNCTIONS.....	75-8 6	FLASH PHOTOGRAPHY .....	111-131
PRINT TYPE.....	76-77	SITUATIONS WHERE FLASH IS REQUIRED.....	112
PRINT QUANTITY .....	78	TYPE OF TTL AUTO FLASH .....	112-113
MID-ROLL CHANGE .....	79-80	<b>FLASH SYNC MODE</b> .....	114-116
DATA RECORDING AND DATA PRINTING., .....	81	USING <b>BUILT-IN FLASH</b> .....	117-122
<b>PRINTING DISPLAYED DATE/TIME</b> .....	82-83	USABLE LENSES WITH BUILT-IN FLASH .....	117
<b>SETTING TITLE</b> .....	<b>84-86</b>	BUILT-IN FLASH OPERATION.....	118-120
SPECIAL FUNCTIONS .....	87-110	FLASH SHOOTING DISTANCE RANGE .....	121
<b>SELF-TIMER OPERATION</b> .....	<b>88</b>	SHUTTER SPEED/APERTURE IN FLASH SHOOTING..	122
<b>EXPOSURE COMPENSATION</b> .....	<b>89-98</b>	<b>FLASH EXPOSURE BRACKETING</b> .....	123-125
ABOUT EXPOSURE COMPENSATION .....	89	<b>FLASH OUTPUT LEVEL COMPENSATION</b> .....	<b>126-128</b>
AUTO EXPOSURE LOCKFUNCTION WITH		<b>USING ACCESSORY NIKON SPEEDLIGHT</b> .....	129-131
AE-L BUTTON .....	90-91	SPEEDLIGHT COMPATIBILITY .....	129
TO OBTAIN METER READING FOR A PARTICULAR		WHAT YOU CAN DO WITH NIKON SPEEDLIGHTS..	130
SUBJECT IN MANUAL EXPOSURE MODE .....	92-93	NOTES ON FLASH PHOTOGRAPHY.....	131
EXPOSURE COMPENSATION FUNCTION.....	94-95	MISCELLANEOUS .....	132-151
AUTO EXPOSURE BRACKETING.....	96-98	<b>FOR NON-CPU LENSES</b> .....	133
<b>MULTIPLE EXPOSURES</b> .....	99-101	<b>OPTIONAL ACCESSORIES</b> .....	134
<b>LONG TIME EXPOSURE USING bui. b SETTING</b> ..	102-10 3	<b>FOCAL LENGTH CONVERSION</b> .....	135
QR (QUICK RECALL) FUNCTION .....	104-105	<b>CAMERA CARE TIPS</b> .....	136-137
MANUAL FILM SPEED SETTING .....	106-1 07	<b>NOTES ON BATTERIES</b> .....	<b>138</b>
MANUAL FOCUS .....	108	<b>GLOSSARY</b> .....	<b>39-i 43</b>
<b>SPECIAL FOCUSING SITUATIONS</b> .....	<b>109-1 10</b>	<b>LCD PANEL/VIEWFINDER INDICATIONS</b> .....	<b>144-1 47</b>
		<b>SPECIFICATIONS</b> .....	148-151

# FOREWORD

---

Thank you for purchasing the new Nikon Pronea 6i.

The Nikon Pronea 6i represents a new dimension in SLR photography — an IX240 camera with many of the exciting features of conventional Nikon 35mm SLRs.

Get to know your Pronea 6i, but before using it, be sure to read this manual thoroughly. Then turn your vision into reality.

## About Advanced Photo System

The Advanced Photo System provides the following features:

- Mid-Roll Change enables you to rewind film before you reach the end of the roll, then use the partially exposed film again. (Pages 79-80)
- Film loading is extremely simple. (Pages 29-31)
- Visual Exposure Indication (VEI) enables you to determine film status—unexposed, partially exposed, fully exposed or processed. (Page 28)
- Three print types are available on the same film. (Page 76-77)
- You can set the desired print quantity for each frame. (Page 78)



Advanced Photo System symbol is a trademark of all IX240 products.

---

Have Nikon spot check your camera regularly  
Nikon recommends that you have your camera serviced by an authorized dealer or service center at least once every two years.

**Using your camera correctly**

The Pronea 6i camera's performance has been optimized for use with Nikon brand accessories. Accessories made by other manufacturers may not meet Nikon's criteria for specifications, and nonconforming accessories could damage the Pronea 6i's components. Nikon cannot guarantee the Pronea 6i's performance when it is used with other than Nikon brand accessories.

# NOMENCLATURE

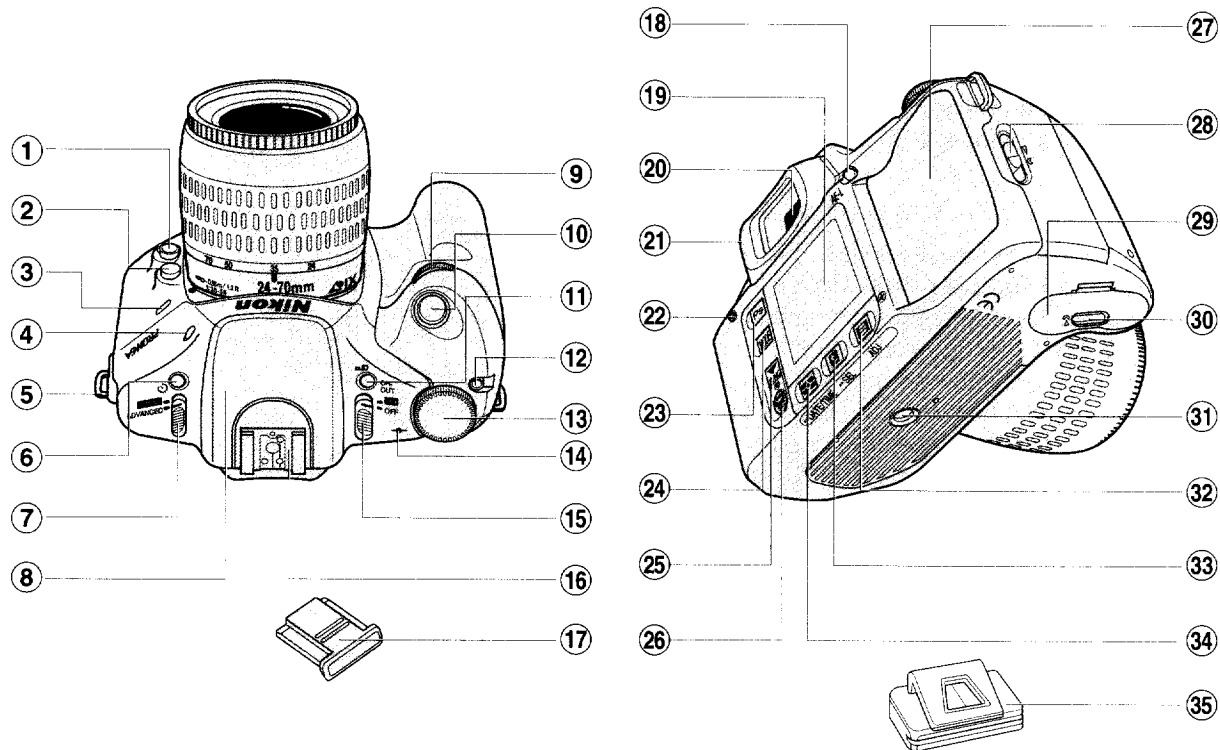

- ① **Focus mode selector:** **AF** for autofocus (pp. 63-71); **M** for manual focus (p. 108).
- ② **Lens release button**
- ③ **Self-timer indicator LED** (p. 88)
- ④ **Flash lock-release button:** Press to activate built-in flash (p. 118).
- ⑤ **Camera strap eyelet**
- ⑥ **Self-timer (⏻) button** (p. 88)
- ⑦ **BASIC/ADVANCED switch** (p. 38)
- ⑧ **Built-in flash** (pp. 117-128).
- ⑨ **Sub-Command Dial**
- ⑩ **Shutter release button**
- ⑪ **QR-OUT button:** See p. 104 for QR (Quick-Recall) function.
- ⑫ **Release terminal:** Accepts optional Nikon Cable Release AR-3. When connecting cable release, turn the camera's power off. When not using the release terminal, always attach the cover provided.
- ⑬ **Main-Command Dial**
- ⑭ **Film plane indicator:** Exact distance from lens mounting flange to film plane is 46.5mm.
- ⑮ **Power switch**
- ⑯ **Accessory shoe:** For Nikon dedicated Speedlight. (See p. 129 for Speedlight compatibility).
- ⑰ **Accessory shoe cover**
- ⑱ **AE-L (Auto Exposure Lock) button** (p. 90-91)
- ⑲ **LCD panel**
- ⑳ **Viewfinder eyepiece**
- ㉑ **Rubber eyecup DK-9**
- ㉒ **LCD panel illuminator button** (p. 9)

- ㉓ **Vari-Program (Ps) button:** Press to select Vari-Program option (p. 41).
- ㉔ **Exposure mode (MODE) button** (p. 46)
- ㉕ **Function (FUNC) button:** Press to select function to be set.
- ㉖ **Function set (SET) button:** Press to set selected function.
- ㉗ **Film cartridge chamber cover**
- ㉘ **Film cartridge chamber cover lock release** (p. 14)
- ㉙ **Battery chamber cover**
- ㉚ **Battery chamber cover lock release** (p. 25)
- ㉛ **Tripod socket**
- ㉜ **Print type/Print quantity (🖨️) button** (p. 76)
- ㉝ **Exposure compensation (⬆️) button** (pp. 94-95)
- ㉞ **Metering (☀️) button** (p. 60)
- ㉟ **Eyepiece cover:** To attach, remove DK-9.

For buttons and Main-/Sub-Command Dial functions, see pages 11 to 12.

Main-Command and Sub-Command Dials are illustrated throughout this instruction manual as shown below:

Main-Command Dial



Sub-Command Dial



## LCD panel indication

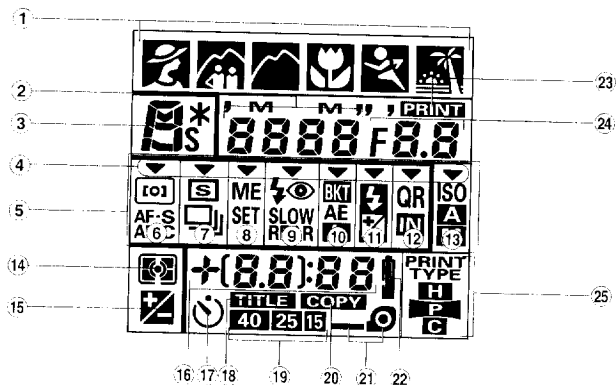

- ① Vari-Program
- ② Shutter speed\*\*
- ③ Exposure mode
- ④ Function area indicators
- ⑤ Function areas
- ⑥ Focus area/AF mode
- ⑦ Film advance mode
- ⑧ Multiple exposure
- ⑨ Flash sync mode
- ⑩ Auto Exposure Bracketing/Flash Exposure Bracketing
- ⑪ Flash output level compensation

- ⑫ Quick Recall function
- ⑬ Film speed setting mode
- ⑭ Metering system
- ⑮ Exposure Compensation
- ⑯ Frame counter/Compensation value/QR number/Film speed/Number of exposures for multiple exposure/Language number/Title number\*
- ⑰ Self-timer
- ⑱ Title
- ⑲ Total number of exposures in cartridge

- ⑳ Print quantity
- ㉑ Film cartridge
- ㉒ Battery
- ㉓ Data print
- ㉔ Aperture\*\*
- ㉕ Print type

\* Shows time when camera power is off.

\*\* Shows date when camera power is off.



## To illuminate LCD panel



With camera's power turned on, press the LCD panel illuminator button. The LCD panel illuminator switches off when the LCD panel illuminator button is pressed again or when the shutter release button is lightly pressed.

## Replacing illuminator panel

When LCD panel illuminator does not function well, contact an authorized Nikon dealer or service facility. You can have the illuminator panel replaced at a nominal charge.

## About LCD

- At high temperatures (60°C/140°F or above), the entire display turns black, making it hard to read display information. When the temperature drops, the display can be read normally again.
- When the temperature drops low, the LCD's response time slows. When the temperature rises, the display works normally again.

## Viewfinder indication

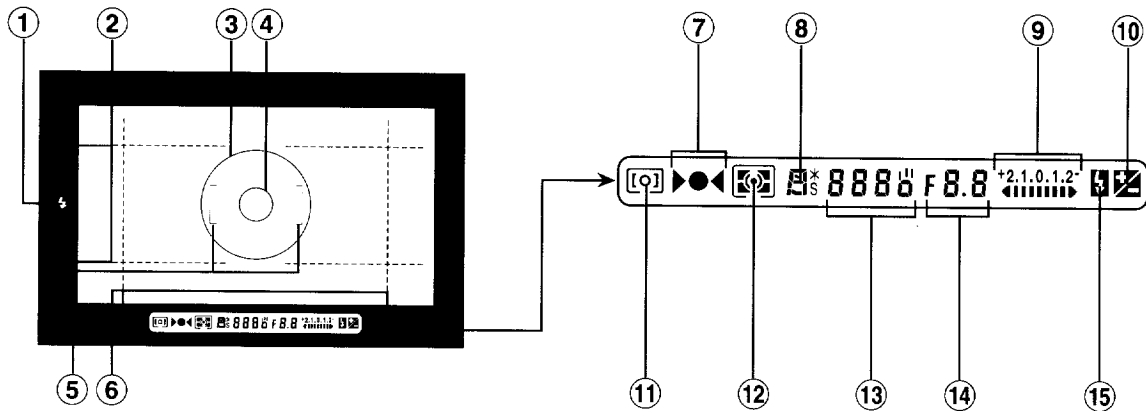

- ① Flash ready-light (red)/Flash recommended light (green)
- ② Panorama (P) type indicators
- ③ 8.4mm-dia. reference circle for Center-Weighted Metering
- ④ 2.5mm-dia. reference circle for Spot Metering/Spot-Area AF
- ⑤ Wide Area focus brackets
- ⑥ Classic (C) type indicators
- ⑦ Focus indicators:
  - indicates a subject is in focus.
  - Blinking ► ◀ indicates autofocus is not possible.
  - or ◀ arrow indicates front or rear focus.

- ⑧ Exposure mode
- ⑨ Electronic analog display
- ⑩ Exposure compensation
- ⑪ Focus area
- ⑫ Metering system
- ⑬ Shutter speed
- ⑭ Aperture
- ⑮ Flash Output Level Compensation

## Buttons and Command Dials

Used with various buttons, the Main-Command Dial/Sub-Command Dial lets you set various functions.

### Vari-Program (p. 40)



### Exposure mode (p. 46)

P S A M

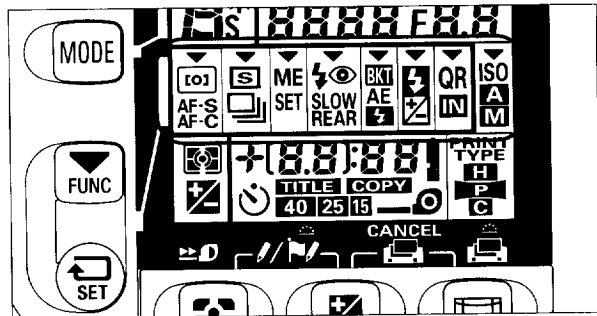

**Functions/modes indicated in Function Zone:** Focus area/AF mode (p. 63), film advance mode (p. 72), multiple exposure (p. 99), flash sync mode (p. 114), Auto Exposure Bracketing (p. 96)/Flash Exposure Bracketing (p. 123), flash output level compensation (p. 126), QR function (p. 104) and film speed setting mode (p. 106)

Selecting function/mode

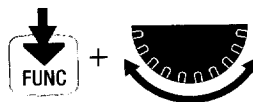

Setting function/mode

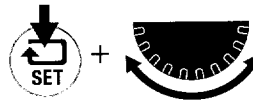

### Metering system (p. 60)

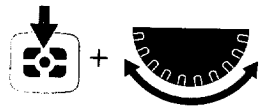

### Exposure compensation (p. 94)

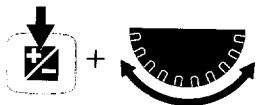

### Self-timer operation (p. 88)



### QR recall (p. 104)

-- 1- -2- -3-

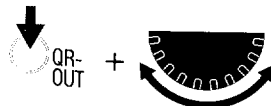

### Print type (p. 76)



### Print quantity (p. 78)



### Title (p. 84)



Selecting language



Setting title No.

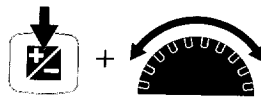

### Two-Button Reset (p. 74)

Press and hold two green buttons, (i.e., Ps and ) for more than two seconds.

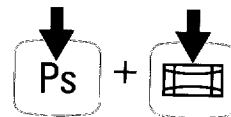

# **BEFORE SHOOTING**

This section shows how to prepare the camera for shooting—e.g., how to mount lens, install batteries, hold camera, confirm date/time, install film, etc. Be sure to master this section before proceeding further.

## INSTALLING BATTERY FOR DATE/TIME BACKUP

The built-in clock is powered by batteries inside the camera body. To provide a backup for the date/time setting (in case camera's batteries are exhausted or removed), however, install a CR2025-type lithium battery in the battery chamber inside the film cartridge chamber.

*The battery for date/time backup requires installation via the film cartridge chamber; you cannot install it while a film cartridge is loaded.*

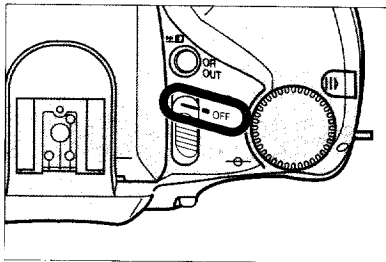

**1** Turn the camera power off.

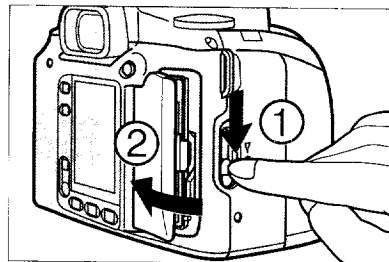

**2** Slide cartridge chamber cover lock release down to open the cartridge chamber.

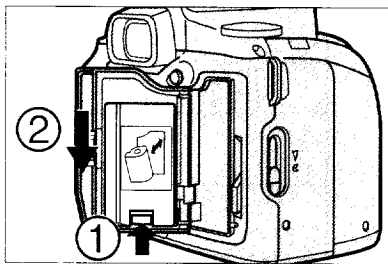

3 Remove battery chamber cover.

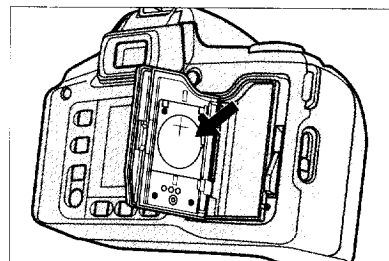
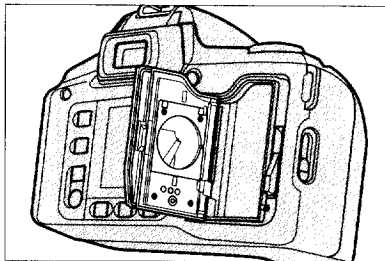

4 Insert one CR2025-type lithium battery as illustrated inside the chamber.

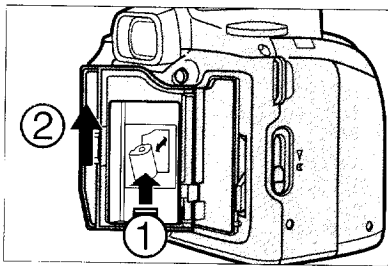

5 Attach the battery chamber cover.

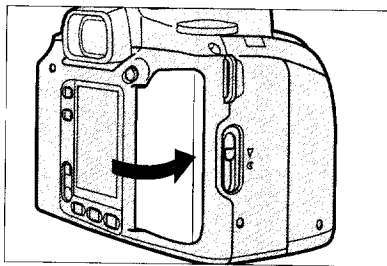

6 Close the cartridge chamber cover and press until lock release snaps closed.

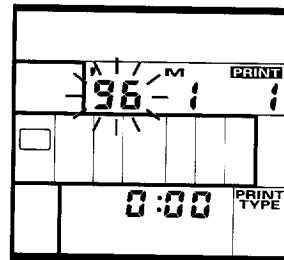

7 Check LCD.

Date indication shows blinking "96-1-1" and time indication shows blinking "0:00". Set the correct date and time. (See pages 19 to 21).



## CHECKING BATTERY POWER FOR DATE/TIME BACKUP

If the built-in clock is left without power from the camera's battery, the date/time backup battery will be exhausted in approx. five months.

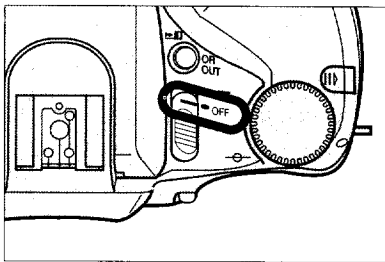

**1** Turn the camera's power off.

If batteries for the camera body have been installed already, remove them.

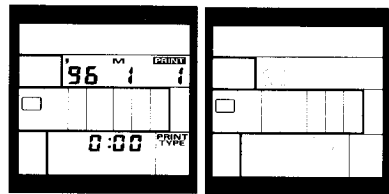

**2** Check LCD.

If the LCD appears clearly, battery power is sufficient for date/time backup.

If the LCD begins to fade or goes out, replace battery for date/time backup.

## Replacing battery for date/time backup

Be sure that you have installed batteries in the camera body. With batteries inside the camera body, you do not have to set correct date/time after replacing the battery for date/time backup.

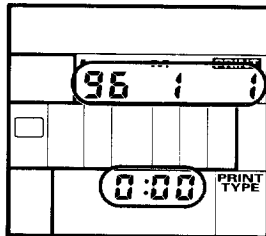

Without batteries in the camera body, replacing the battery for date/time backup resets the date/time to 0:00, January 1st, 1996.

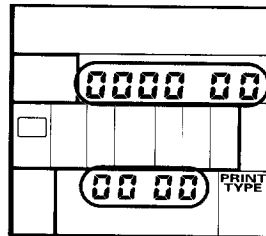

If you replace the backup battery without batteries inside the camera body, set the correct date and time. (See pages 19 to 21.) After two minutes, the date and time appear as "0000 00" and "00 00", telling you that the correct date and time have not been set. If you install batteries in the camera and turn the camera power on without setting the correct date/time, the built-in clock will start from 00:00, January 1st, 1996. Releasing shutter with an incorrect date/time set causes the incorrect date/time to be inscribed on the back of the print ("backprinted").

## SETTING DATE/TIME

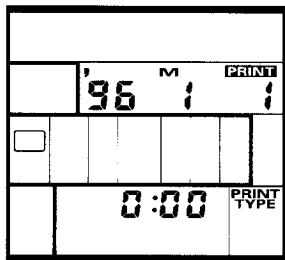
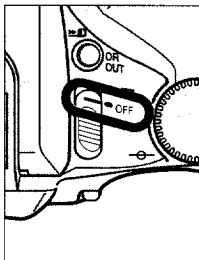

Data such as date and/or time are always recorded on the film and backprinted on the picture. (If desired, you can have the data frontprinted on pictures.)\* Before shooting, slide the power switch to OFF to confirm date and time, then set the correct date/time if necessary.

\* Data printing service is available from authorized photofinishers (see page 81).



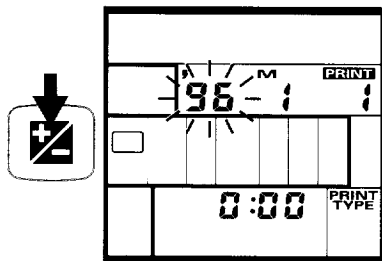

### To adjust date/time

- ☒ button Press to select an indication to be adjusted. (To begin adjusting date/time press ☒ button twice.)
- ▭ button Press to adjust a numerical indication. To change numerical indication rapidly, hold down the ▭ button.

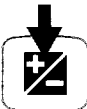

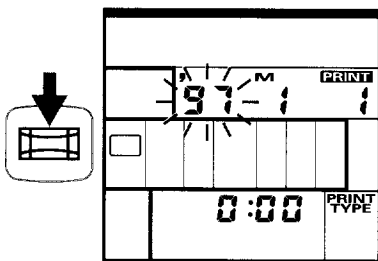
1 Press  button until the indication to be adjusted starts blinking. (Clock stops while indication continues blinking.)



2 Press  button to adjust the indication.

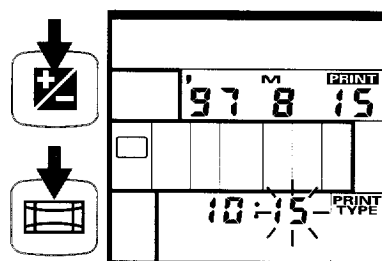

3 Repeat steps 1 and 2 until date and time are correctly set.

**To set time to precise second:** Advance the time one minute ahead of actual time. When actual time coincides with the time you have set, push  button to start the clock.

- Non-existent dates (i.e., February 30, June 31) cannot be set.
- To change data for printing, see page 82.
- For printing data, see page 81.

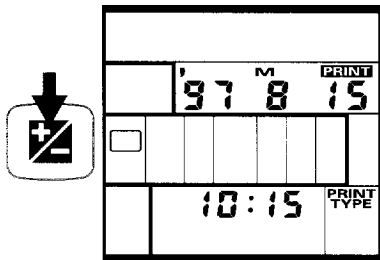

- 4 Press button until the date/time display appears without blinking and the clock starts.

# MOUNTING LENS

## Usable lenses

Use Nikkor CPU lenses, as listed below:

- IX-Nikkor lenses
- D-type AF Nikkor lenses (including AF-I and AF-S Nikkor lenses)
- Non-D-type AF Nikkor lenses (except AF Nikkor for F3AF)
- AI-P Nikkor lenses (manual focus only)

For lens compatibility, see page 133.

## When using CPU lenses other than IX-Nikkor lenses, note the following:

- Set the lens aperture ring to its minimum aperture (the largest f-number), then lock the lens aperture ring. (See lens instruction manual.)

When a lens is not set to its minimum aperture setting and the camera is turned on, **FE** blinks in the LCD panel and inside viewfinder and the shutter locks.

With the Pronea 6i, all aperture setting operations are performed with the Sub-Command Dial. Do not move the lens aperture ring once it is set to its minimum aperture (largest f-number).

## When mounting/removing lens

- Make sure that the camera's power switch is turned off.
- Avoid direct sunlight.

## Focal length conversion

Since IX240 film differs in size from 135 film, the images obtained by the same lens are also different. For details, see page 135.

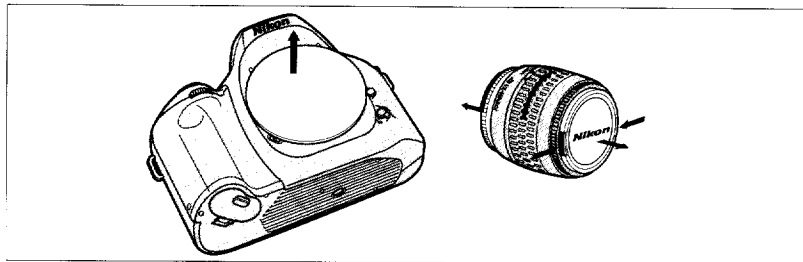

1 Remove the camera body cap and the front and rear lens caps.

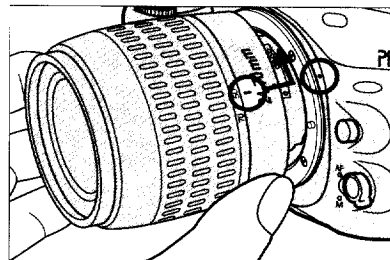

2 Position the lens in the camera's bayonet mount so the mounting indexes on the lens and camera body are aligned. Taking care not to press the lens release button, twist the lens counterclockwise until it locks into place.

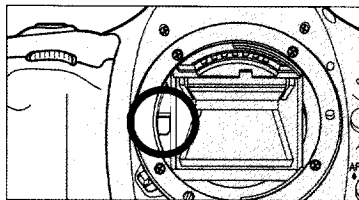

Aperture coupling lever

#### Mount IX-Nikkor lens carefully

Do not bump the aperture coupling lever inside the camera's mounting flange against the rear edge of the lens. A damaged aperture coupling lever could cause the camera to malfunction.

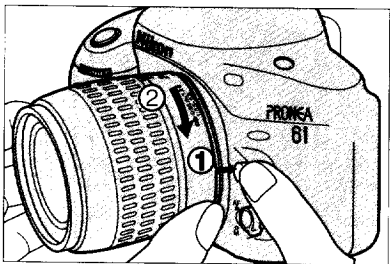

**To remove**

Push and hold the lens release button, then turn the lens clockwise.

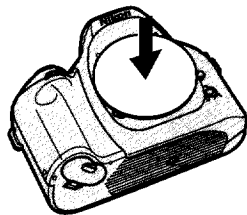

**Storing camera body without attached lens**

To prevent dust from entering the body, always attach the body cap provided or optional Body Cap BF-1A. (The BF-1 body cap cannot be attached to the Pronea 6i.)



## INSTALLING BATTERIES

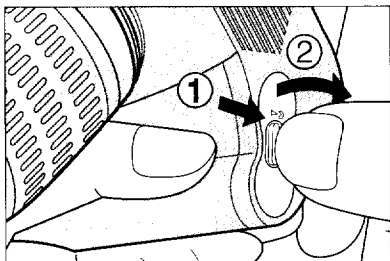

**1** Make sure the power switch is set to OFF position, then open the battery chamber cover by sliding the lock release.

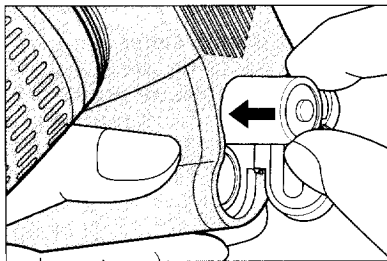

**2** Insert two CR123A lithium batteries with the "+" and "-" ends positioned as illustrated inside the cover.

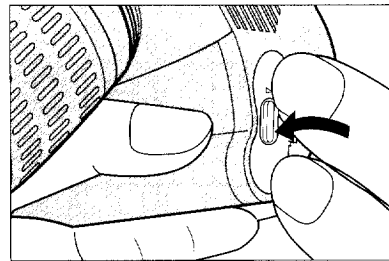



**3** Close cover by pushing until it clicks.

Before installing/replacing batteries, be sure to read "NOTES ON BATTERIES", page 138.

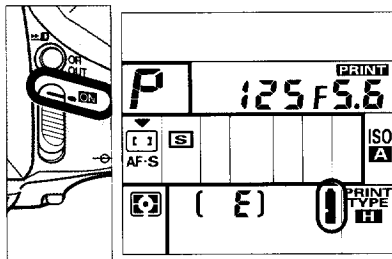
## CHECKING BATTERY POWER



Slide power switch to ON position and confirm that a full battery mark  appears in the LCD panel to indicate sufficient battery power. (The battery mark automatically turns off after 8 sec.)  
If  appears: Batteries are nearing exhaustion. Have a fresh set ready.  
If  blinks (with or without blinking **Err**): Batteries are just about exhausted. Slide power switch to OFF and replace batteries with a fresh set.

### About exposure meter

Battery power can be checked anytime by lightly pressing the shutter release button. This activates the exposure meter, LCD panel and viewfinder indications, and starts autofocus (unless camera is set for manual focusing). All indications, including the battery mark, stay on for approx. 8 sec. after you take your finger from the shutter release button, then automatically turn off.

Without the flash, if you remove your finger from the shutter release button, the LCD readouts go off approx. 2 sec. after shutter is released. When the built-in flash or a Speedlight is activated, the LCD readouts stay on approx. 8 sec. after the shutter is released.

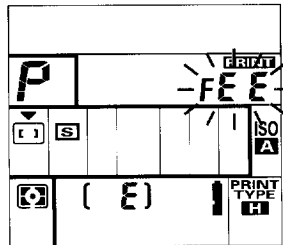

### A blinking **FEE** in the aperture position indicates a lens setting error.

Lens (other than iX-Nikkor lens) is not set to its minimum aperture, which causes the shutter to lock. Set lens to its minimum aperture.



## HOLDING CAMERA/PRESSING SHUTTER RELEASE BUTTON

Before installing film, familiarize yourself with holding the camera.

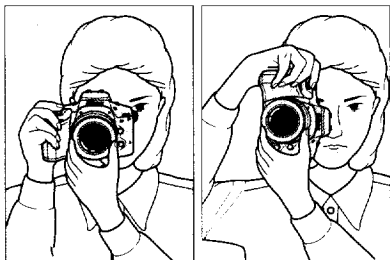

Stand with one foot forward a half step to balance your body.

Grasp the camera hand grip with your right hand, and use your left hand to cradle the camera with your elbow propped against your body for support, as you look through the viewfinder.

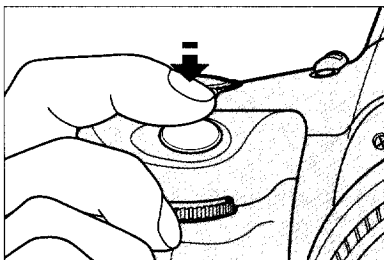

Lightly press shutter release button to activate exposure meter and start autofocus.

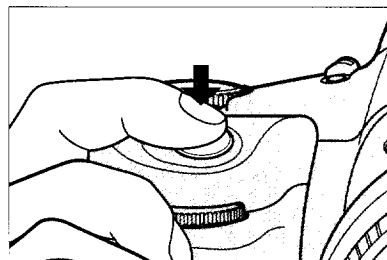

Fully depress shutter release button to release shutter.

Apply light but steady pressure with the ball of your index finger to avoid camera shake that might result in a blurred image.

### For test release

To release the shutter for test purposes without the lens attached, set exposure mode to Manual.

## INSTALLING FILM CARTRIDGE

Use only IX240 films with the Pronea 6i. (Do not use conventional 135 film.)

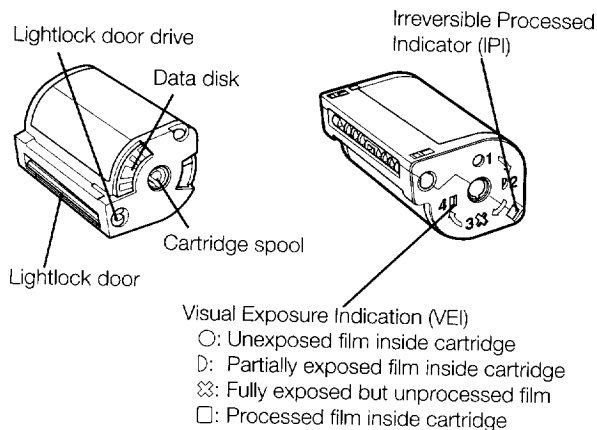

- Before installing film, confirm that the Visual Exposure Indication shows ○ (unexposed) or ◐ (partially exposed).
- There is no film leader; film is automatically thrust and loaded inside the camera.

### Notes about the IX240 film cartridge

- Do not disassemble or subject to shock or vibration.
- Be careful not to soil or damage the cartridge contacts, as correct data communication may be impaired.
- Do not press on the lightlock door drive with a pointed object (e.g., a pen), as this may damage camera body or cause camera malfunction. Also this may open the door and expose the film.
- Do not break the Irreversible Processed Indicator (IPI) on the cartridge, as film processing and printing may become impossible. Consult your photofinisher if IPI is broken.
- Do not attempt to rotate the cartridge spool with a pointed object (e.g., a screwdriver). This can expose the film, alter the Visual Exposure Indication (VEI), or prevent proper use and/or processing.
- Do not store the film cartridge:
  - a) In direct sunlight, near heating, appliances or in a hot place.
  - b) Around dirt or dust.
  - c) In hot or humid and moldy environments
  - d) Near strong magnetic devices

### For processing and printing IX240 films

We recommend bringing your IX240 film cartridge to a photofinisher displaying the "Certified Photofinisher Mark" sign for processing and printing.



Certified Photofinisher Mark

### Certified photofinishers offer the following services

Three different print types

Classic (C), wide-vision (H) and panorama (P) types are available. See page 76.

#### Data printing

See page 81.

#### Index Prints

Positive images of all exposed frames are printed on one sheet.

#### Negative Return in Cartridge (NRIC)

Your negatives are returned inside the cartridge for easy storage.

For further details, ask your certified photofinisher.

## Installing film cartridge

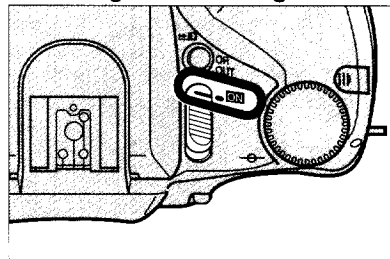

- 1 Slide the power switch to ON.

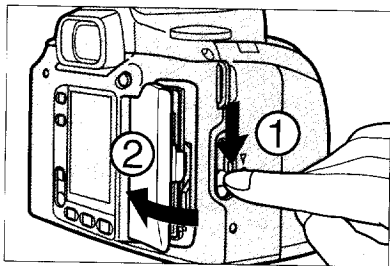

**2** Slide film cartridge chamber cover lock release down to open the cover.

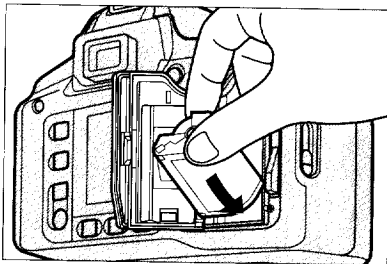

**3** Insert the film cartridge from the bottom.

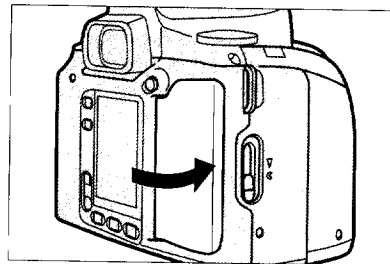

**4** Close the film cartridge chamber cover and press until the lock release snaps closed.

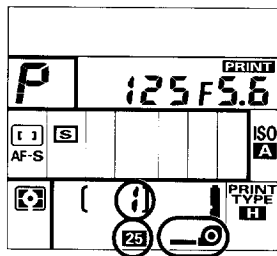

5 The film automatically advances to frame one.

Film cartridge symbol (—) and total number of exposures in cartridge (40, 25 or 15) appear in the LCD panel.

- When a partially exposed film is installed, the camera automatically advances the film to the frame following the last-exposed frame and the frame counter shows the corresponding number.
- If an already exposed film or a damaged film is installed, **Err** and **E** blink in the LCD panel. Wait for the frame counter to show **E**, then replace the film cartridge.
- To check whether film is installed or not (i.e., whether — appears or not), always turn the camera power on. (With the camera power turned off, the LCD shows only date/time.)

#### To check ISO film speed setting

Hold **FUNC** button and rotate the Main-Command Dial until the function set indicator (▼) appears in the film speed setting area and **ISO** and **A** start blinking. Then remove your finger from **FUNC** button and press **SET** button. The film speed appears in place of the frame counter.

# BASIC OPERATION

This section shows you how to take shots in BASIC mode, for the most common picture-taking situations, and explains automatic rewinding after shooting.

Note that AF Nikkor lenses (IX-Nikkor lenses and D-type AF Nikkor lenses, or non-D-type AF Nikkor lenses) are required for the basic operations shown in this section.



# BASIC SHOOTING

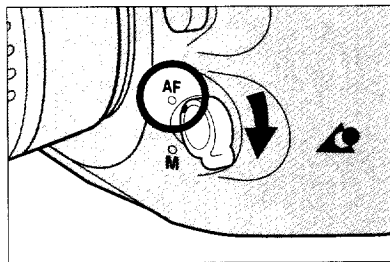

1 Set focus mode selector to AF.

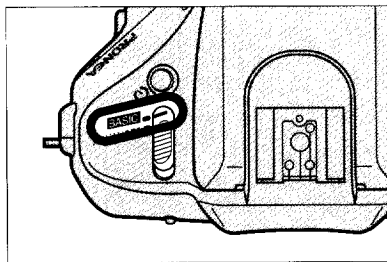

2 Set BASIC mode. **bR5 iC** appears in the LCD panel.

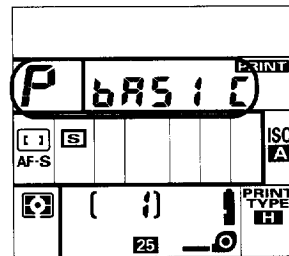

In BASIC, the exposure mode, metering system, focus area, AF area, film advance mode, flash sync mode and film speed setting mode are automatically set as follows:

Exposure mode:	Auto-Multi Program ( <b>P</b> )*1
Metering system:	3D Matrix ( <b>i</b> )
Focus area:	Wide ( <b>L1</b> )
AF mode:	Single Servo AF ( <b>AF-S</b> )
Film advance mode:	Single-frame ( <b>S</b> )
Flash sync mode:	Normal*2
Film speed setting mode:	Auto ( <b>A</b> )

\*1 Can be switched to Vari-Program. (See page 41).

\*2 With a built-in flash or Nikon Speedlight turned on,  appears for normal sync. If an attached Nikon Speedlight is set at Rear-Curtain Sync, Rear-Curtain sync will be performed.



**3** Look through the viewfinder and position focus brackets on the main subject.

- For hints on camera holding, see page 27.

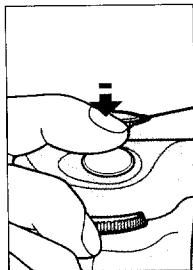

**4** Lightly press the shutter release button to start autofocus operation and switch the exposure meter on.

Confirm that the in-focus indicator ●, shutter speed and aperture indications appear in the viewfinder LCD.

- For Flexible Program, which lets you change the shutter speed/aperture combination, see page 51.

### **If the distance between you and a stationary subject changes**

In BASIC mode, Single Servo AF is automatically selected. In Single Servo AF mode, after focusing is achieved and the in-focus indicator ● appears, focus remains locked as long as the shutter release button is lightly pressed. If the distance between you and the stationary subject changes, remove your finger from the shutter release button, then lightly press it again to refocus. For details on Single Servo AF, see pages 67-68.

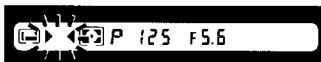

**If ► ◀ blinks—AF impossible alert**

Autofocus is not possible with the subject and shutter locks. (p. 109)

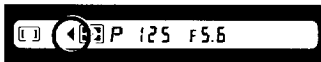

**If ◀ remains on—Too-near-subject alert**

If subject is located closer than the lens' closest focusing distance, the shutter locks. Move away from the subject and refocus.



**If H i appears in the shutter speed position—Overexposure alert**

Use Nikon ND or similar filter.



**If Lo appears in the shutter speed position—Underexposure alert**

Use a built-in flash/ Nikon Speedlight, higher ISO film or a lens with wider aperture.

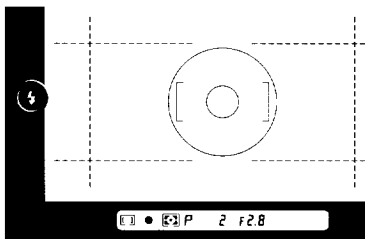

**If green ⚡ mark appears—Flash photography recommended**

If available light is insufficient, a green mark ⚡ appears. Use built-in flash or Nikon Speedlight.

## AFTER SHOOTING

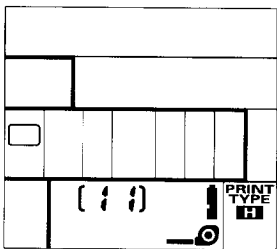

- 1 When you reach the end of the roll, film automatically starts rewinding. During film rewind, the frame counter counts backwards until rewind is complete.

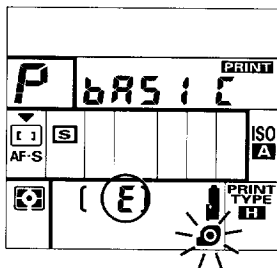

- 2 Confirm frame counter shows **E** and  blinks to indicate film is completely rewound.

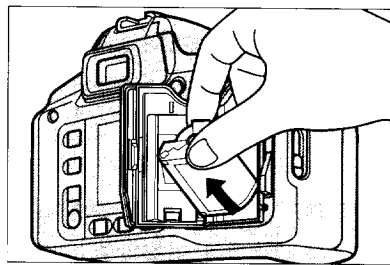

- 3 Open the film cartridge chamber cover and remove the film cartridge.
- The film cartridge chamber cover remains locked until film rewind is complete. Do not attempt to forcibly open the cover.
  - To protect the film cartridge, remove it immediately after film rewind is complete.

- Film can be rewound before you reach the end of the roll, and the partially exposed film can be used again. (See page 79).
- If film rewind stops at mid-roll, check the battery power. If  blinks in the LCD panel, turn the power switch off, replace batteries with a fresh set, then turn power on. The film will automatically start rewinding.
- Data is recorded\* during film rewinding. To ensure proper data recording, do not shock the camera during film rewinding. If data recording is performed improperly, **Err** and **PRINT** blink in the LCD panel. Even with improper data recording, however, film can be processed and printed.

\* For details on data recording, see pages 81 to 86.

# **GENERAL FUNCTIONS**

This section explains the various modes of Pronea 6i camera operation.

## ADVANCED MODE AND BASIC MODE

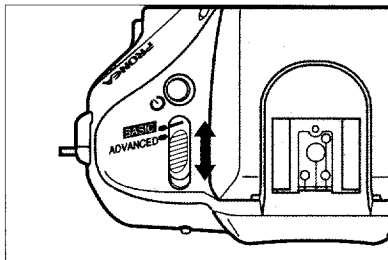

In BASIC mode, available functions and choices are limited to minimize concerns regarding which functions/modes to select. In ADVANCED mode, you can take advantage of the full range of Pronea 6i features.

Functions/modes	In BASIC mode	In ADVANCED mode	Refer to
Vari-Program	Six options are selectable		pp. 40-43
Exposure mode* (excluding Vari-Program)	Fixed at Auto-Multi Program	Auto-Multi Program, Shutter-Priority Auto, Aperture-Priority Auto and Manual are selectable	pp. 46-48
Metering system*	Fixed at Matrix	Matrix, Center-weighted and Spot are selectable	pp. 60-62
Focus area/AF mode*	Fixed at Wide with Single Servo AF	Wide with Single Servo AF, Wide with Continuous Servo AF, Spot with Single Servo AF, and Spot with Continuous Servo AF are selectable	pp. 63-66
Film advance mode*	Fixed at single-frame	Single-frame and continuous are selectable	pp. 72-73
Flash sync mode*	Fixed at Normal Sync	Normal Sync, Red-Eye Reduction, Red-Eye Reduction with Slow-Sync, Slow Sync and Rear-Curtain Sync are selectable	pp. 114-116
Film speed setting* mode	Fixed at auto	Auto and manual are selectable	pp. 106-107
Print type	H, P and C are selectable		pp. 76-77
Print quantity	Available		p. 78
Mid-roll rewind	Available		pp. 79-80

Functions/modes	In BASIC mode	In ADVANCED mode	Refer to
Title	Available		p. 85
Setting date/time	Available		pp. 82-83
Flexible Program	Available		pp. 51-52
AE lock	Available		pp. 90-91
Self-timer	Available		p. 88
Built-in flash	Available		pp. 118-120
Two-Button Reset	Not available	Available	p. 74
Exposure compensation*	Not available	Available	pp. 94-95
Flash output level compensation*	Not available	Available	pp. 126-128
Auto Exposure Bracketing	Not available	Available	pp. 96-98
Flash Exposure Bracketing	Not available	Available	pp. 123-125
Long Time Exposure	Not available	Available	pp. 102-103
Multiple exposure	Not available	Available	pp. 99-101
QR (Quick Recall) function	Not available	Available	pp. 104-105

\* Setting BASIC mode, then returning to ADVANCED reactivates the previously set mode/functions.

# VARI-PROGRAM

---

## WHAT IS VARI-PROGRAM?

Programmed Auto exposure control enables the camera's computer to automatically adjust both lens aperture and shutter speed for the correct exposure. The Pronea 6i camera's Matrix Metering System (page 60) determines the correct exposure, applying exposure compensation as deemed necessary by the computer's program. However, other factors can affect the picture, including the use of different shutter speeds and different apertures.

The Pronea 6i's Auto-Multi Program is designed to coordinate the selection of shutter speed and aperture for average situations. It guides the exposure control system into using reasonably high shutter speeds to avoid blur due to camera shake. The Pronea 6i incorporates a versatile Vari-Program System that gives you the option to choose from different programs, each designed to accommodate different picture-taking situations. Please review the concept behind and recommended use for each program, using each as described, or in a different way to express your own picture-taking creativity. Once you understand how each program operates, you'll be able to experiment, using each program for an application different from its originally intended use.

Please note that the effect achieved by using each Vari-Program can be reproduced with the use of other exposure control methods in ADVANCED mode such as Shutter-Priority Auto, Aperture-Priority Auto and Manual. With Vari-Program control, you allow the camera's computer to take care of all exposure control tasks while you concentrate on composition. This versatility is one of the highlights of the Pronea 6i camera's advanced exposure control system.

The Pronea 6i's Vari-Program control offers six programs:

-  Portrait Program
-  Hyperfocal Program
-  Landscape Program
-  Close-Up Program
-  Sport Program
-  Silhouette Program

For features of each program, see "VARI-PROGRAM SELECTION GUIDE" on pages 42 to 43.



## SETTING VARI-PROGRAM

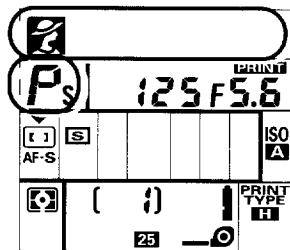
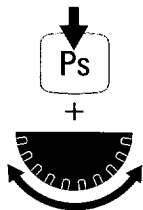

While holding **Ps** button, rotate Main-Command Dial until your desired Vari-Program symbol appears. When Vari-Program is selected, **Ps** appears as exposure indication in the LCD panel.



When Vari-Program is set, camera settings are automatically reset as follows:

Metering system	3D Matrix*
Focus area	<input type="checkbox"/> Wide*, or <input type="checkbox"/> Spot with flash
Flexible Program	Cancel*
Sync mode	Normal Sync**
Exposure compensation function	Cancel*

\* Settings can be changed as desired in **ADVANCED** mode.

\*\* Flash sync mode can be changed to Red-Eye Reduction, Red-Eye Reduction with Slow Sync or Slow Sync, in **ADVANCED** mode. (You cannot set Rear-Curtain Sync with Vari-Program.)

### To cancel Vari-Program

Set the Vari-Program indication between  and  (with no Vari-Program indication) to cancel Vari-Program and activate Auto-Multi Program (i.e., Vari-Program option indication disappears and **P** takes the place of **Ps** in the LCD panel).

In **ADVANCED** mode, you can cancel Vari-Program by holding **MODE** button and setting the Main-Command Dial until your desired exposure mode symbol (**P**, **S**, **A** or **M**) replaces **Ps**.

## VARI-PROGRAM SELECTION GUIDE



### Portrait Program

Used for taking pictures of people, this program creates an artistically blurred background that accentuates your main subject.

For flash photography, to reduce possibility of "red-eye", set the flash sync mode to Red-Eye Reduction or Red-Eye Reduction with Slow-Sync.

Recommended AF Nikkor lenses: To obtain pronounced blurred background effect, use middle-range telephoto lenses.



### Hyperfocal Program

Use this Program when photographing landscapes and other subjects that encompass great depth. The effect becomes more pronounced if there is an interesting foreground within the scene. Hyperfocal Program tends to select a slow shutter speed and smaller aperture to ensure both subject and background are in focus. To avoid camera shake, use a tripod.

Recommended AF Nikkor lenses: Normal or wider angle lenses.

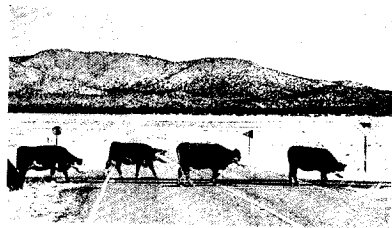

### Landscape Program

Use this Program when taking a picture of a distant scene. Do not use the flash, as the scene will likely be too remote. Landscape Program tends to select a slower shutter speed and smaller aperture to provide sharply focused landscape pictures. To avoid camera shake, use a tripod.

Recommended AF Nikkor lenses: Select the lens according to your desired effect. For an expansive view, use a wideangle lens; to emphasize your subject by magnifying it, use a telephoto lens.



### Close-Up Program

Use this Program when taking pictures up close—a flower, ornamental detail, a butterfly, etc. Do not use flash. To avoid camera shake, use a tripod.

Recommended AF Nikkor lenses: AF Micro-Nikkor lenses.



### Sport Program

Use to freeze the action. Recommended for use with Continuous Servo AF (page 71). Do not use a flash, as it restricts the available shutter speeds.

Recommended AF Nikkor lenses: For a more pronounced blurred background effect, use telephoto lenses.



### Silhouette Program

Effective only when the background is bright and the subject is in a shadow or comparatively dark. The result is dramatic with a wideangle lens although a telephoto can also be used. Excellent for sunsets with a dark foreground silhouette or pictures of people against the sky. Do not use flash. Silhouette Program tends to select a slow shutter speed to produce effectively silhouetted pictures. To avoid camera shake, use a tripod.

Recommended AF Nikkor lenses: Choose your lens according to your desired effect.

## OPERATION IN VARI-PROGRAM

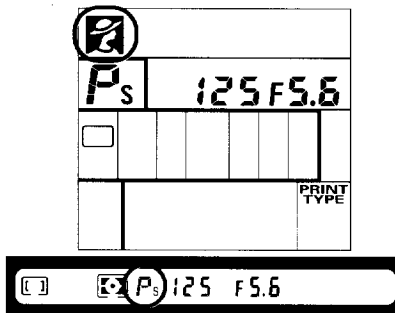
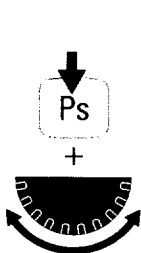

1 While holding Ps button, rotate the Main-Command Dial until desired Vari-Program symbol appears. (In this example, Portrait Program in ADVANCED mode is selected.)

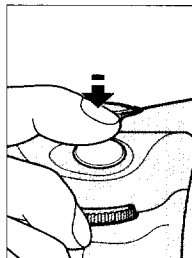

2 Look inside viewfinder, compose your shot and lightly press the shutter release button, then confirm focus.

- For Flexible Program, which lets you change shutter speed/aperture combination, see page 51.

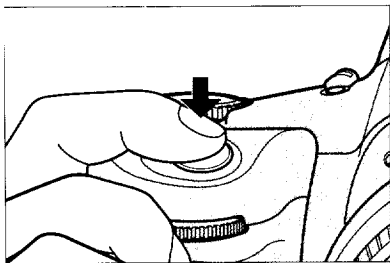

3 To take picture, fully depress shutter release button.

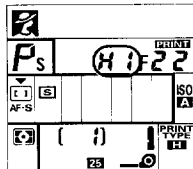

If **H** appears in the shutter speed position—**Overexposure alert**  
Use Nikon ND or similar filter.

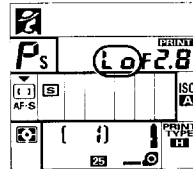

If **L** appears in the shutter speed position—**Underexposure alert**  
Use a built-in flash/Nikon Speedlight, higher ISO film or lens with wider aperture.

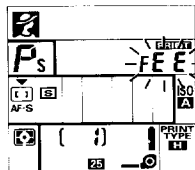

If **FE** blinks in the aperture position—**Lens setting error alert**  
Lens (other than IX-Nikkor lens) is not set to its minimum aperture setting causing shutter to lock. Set lens to its minimum aperture.

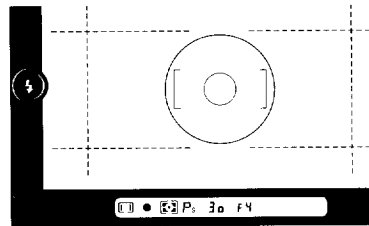

If green **⚡** mark appears—**Flash photography is recommended**  
If available light is insufficient, green **⚡** mark appears. Use built-in flash or Nikon Speedlight.

## EXPOSURE MODE

Light reaching the film is controlled by shutter speed and lens aperture. The proper combination results in a correct exposure. Shutter speed and lens aperture settings are based on the ISO speed set for the film in use and the operation of the camera's exposure control system.

The relationship between aperture and shutter speed is as follows: One change in shutter speed either doubles or halves the amount of light transmitted. For example, a shutter speed of 1/500 sec. passes half the light of 1/250 and double the light of 1/1000 sec. The aperture f/8 passes half the light of f/5.6 and double the light of f/11. If the correct exposure for a scene is 1/500 at f/8, then we can also select 1/250 at f/11 or 1/1000 at f/5.6 and achieve the same exposure results, and so on.

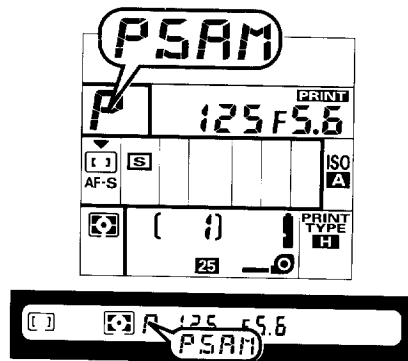

The Nikon Pronea 6i camera offers two types of programmed auto exposure modes, Auto-Multi Program (P) and Vari-Program (Ps), as well as Shutter-Priority Auto (S), Aperture-Priority Auto (A), and Manual (M) exposure modes. While pressing MODE button, rotate the Main-Command Dial to set P for Auto-Multi Program, S for Shutter-Priority Auto, A for Aperture-Priority Auto or M for Manual. Selecting the exposure control mode enables you to determine whether you want the shutter speed and/or lens aperture set automatically or manually.

### To activate Vari-Program

Use Ps button. For details, see pages 41 to 45.



### **Auto-Multi Program (P)**

Auto-Multi Program is used for most common picture-taking situations.

With the Pronea 6i's microcomputer choosing the combination of shutter speed and aperture automatically, you can concentrate on picture composition, without worrying about exposure.

In Programmed Auto exposure mode, you can use the Flexible Program function to temporarily shift an automatically selected shutter speed/aperture combination and obtain the desired shutter speed/aperture (p. 51).



### **Shutter-Priority Auto exposure mode (S)**

Allows you to manually set your desired shutter speed (30 sec. to 1/4000 sec.). To freeze the action, use a higher shutter speed; to create motion effects, choose a slower shutter speed. The Pronea 6i's microcomputer automatically sets the proper aperture to match the manually selected shutter speed for correct exposure. See pages 53 to 54 for Shutter-Priority Auto operation.

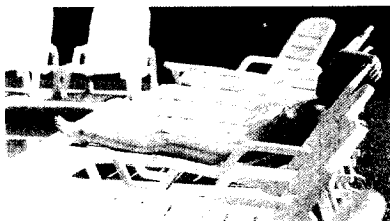

### **Aperture-Priority Auto exposure mode (A)**

Allows you to control the depth of field by varying the aperture. Smaller apertures make the background and foreground sharper (recommended for landscape pictures); larger apertures tend to blur the background (recommended for portraits). The aperture you select will automatically determine the shutter speed set by the camera's microcomputer. For Aperture-Priority Auto operation, see pages 55 to 56.



### **Manual exposure mode (M)**

Manual exposure control allows you to make both aperture and shutter speed settings. For a technically correct exposure, follow the recommendation of the camera's light meter as indicated in the LCD readout. To achieve a specific creative effect (e.g., intentional blur, intentional under- or over-exposure), disregard the LCD and modify the recommended exposure settings.

For Manual exposure operation, see pages 57 to 59.



## OPERATION IN AUTO-MULTI PROGRAM

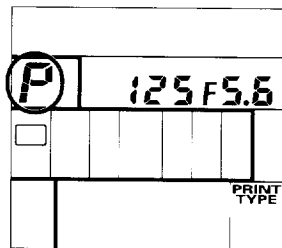
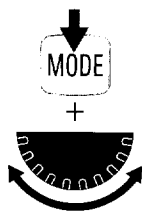

1 While pressing MODE button, rotate Main-Command Dial until **P** for Auto-Multi Program appears in the LCD panel (and viewfinder).

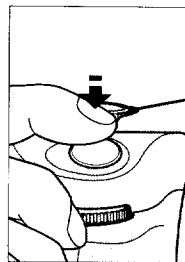

2 Look inside viewfinder, compose your shot and lightly press the shutter release button, then confirm focus and automatically set shutter speed/aperture value.

- For Flexible Program, which allows you to change the shutter speed/aperture combination, see page 51.

If the exposure meter and LCD indications automatically turn off, turn them on again by lightly pressing the shutter release button.

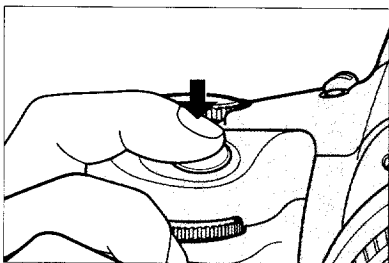

**3** To take picture, fully depress shutter release button.

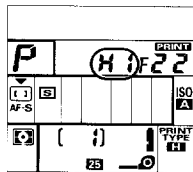

**If H appears—Overexposure alert**

Use Nikon ND filter.

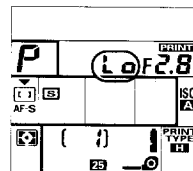

**If L appears—Underexposure alert**

Use built-in flash or Nikon Speedlight.

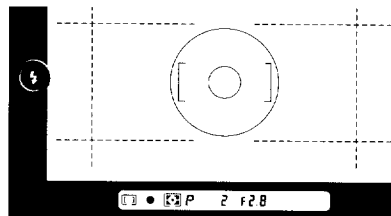

**If green lightning bolt appears—Flash photography is recommended**

Use built-in flash or Nikon Speedlight.

## FLEXIBLE PROGRAM

To change the shutter speed/aperture combination in Auto-Multi Program or Vari-Program, use the Flexible Program function. Flexible Program lets you temporarily shift an automatically set combination of shutter speed/aperture in 1/2 EV steps, while maintaining the correct exposure.

(In the following procedure, ADVANCED mode indications are used for example illustrations.)

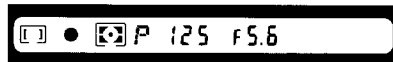
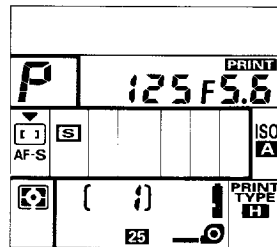
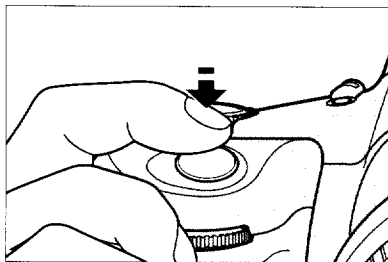

- 1 In Auto-Multi Program or Vari-Program, lightly press the shutter release button.

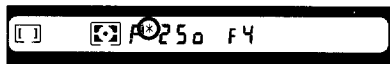
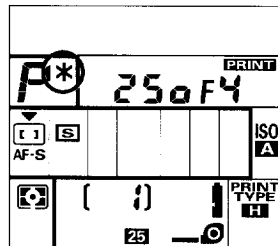

2 Rotate the Main-Command Dial or Sub-Command Dial until your desired shutter speed/aperture combination appears. Note that shutter speed/aperture combinations available may be limited due to subject brightness. To indicate the program has been shifted, the Flexible Program indicator (\*) appears beside the Auto-Multi Program indication or the Vari-Program indication.

- Flexible Program is canceled:
  - a. When you switch the exposure mode to another mode.
  - b. When you change Vari-Program options.
  - c. When Two-Button Reset is performed.
  - d. When camera power is turned off.
  - e. When camera's meter automatically turns off.

#### For BASIC mode

You cannot see the shutter speed and aperture in the LCD panel. Confirm inside viewfinder.

# OPERATION IN SHUTTER-PRIORITY AUTO EXPOSURE MODE

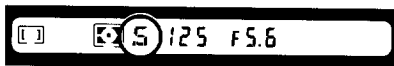
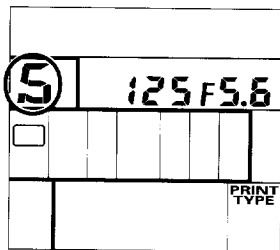
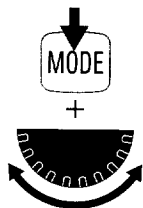

1 While pressing MODE button, rotate Main-Command Dial until **S** for Shutter-Priority Auto appears in LCD panel (and viewfinder).

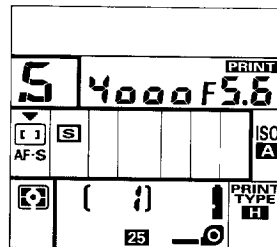

2 Remove finger from MODE button and rotate the Main-Command Dial to set your desired shutter speed. Shutter speed indications change in 1/2 steps in the following sequence:

30" 23" 15" 11" 8" 5,5" 4" 3" 2" 1,5" 1" 1,4  
2 3 4 6 8 11 15 23 30 45 60 90 125 180 250  
350 500 750 1000 1500 2000 3000 4000

If exposure meter LCD indications automatically turn off, turn them on again by lightly pressing the shutter release button.

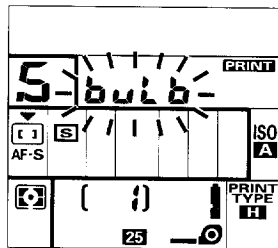

When **bulb** is set on the camera, selecting Shutter-Priority Exposure mode causes the **bulb** indication to blink—a warning that the **bulb** setting cannot be used in Shutter-Priority Auto exposure mode.

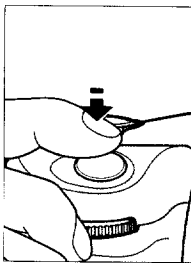

**3** Look inside viewfinder, compose shot and lightly press the shutter release button. Confirm the focus and automatically set aperture value.

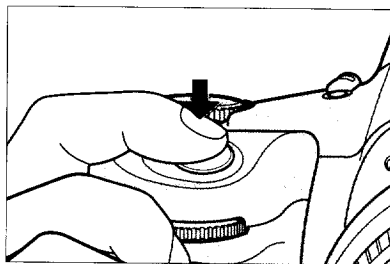

**4** To take picture, fully depress the shutter release button.

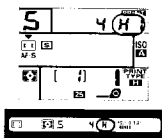

If **H** appears with the electronic analog display\*—**Overexposure alert**  
Select higher shutter speed or use Nikon ND filter.

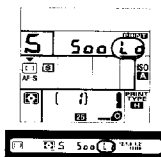

If **L** appears with the electronic analog display\*—**Underexposure alert**  
Select a slower shutter speed, or use the built-in flash or a Nikon Speedlight.

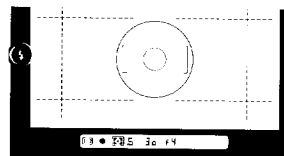

If green lightning bolt appears—**Flash photography is recommended**  
Use the built-in flash or a Nikon Speedlight.

\* Shows the difference in value from a correct exposure. If difference exceeds  $\pm 2EV$ , **L** appears for underexposure, **H** for overexposure.

## OPERATION IN APERTURE-PRIORITY AUTO EXPOSURE MODE

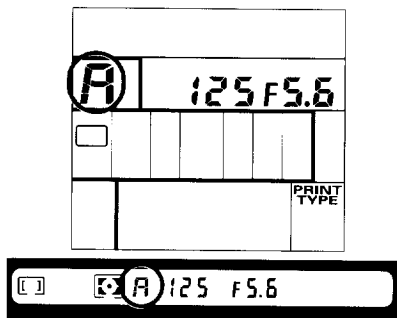
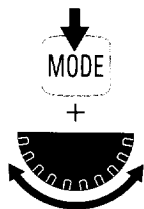

1 While pressing **MODE** button, rotate the Main-Command Dial until **A** for Aperture-Priority Auto appears in the LCD panel (and viewfinder).

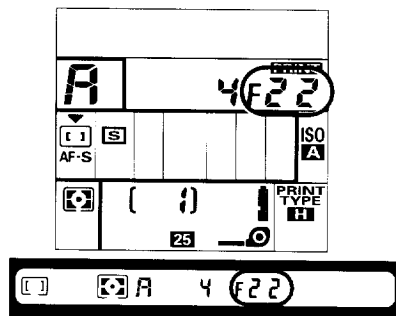

2 Remove finger from **MODE** button and rotate Sub-Command Dial to set your desired aperture.

Aperture indications change in 1/2 steps in the following sequence:

**F 1.4 F 1.7 F 2 F 2.4 F 2.8 F 3.3 F 4 F 4.8 F 5.6 F 6.7 F 8 F 9.5 F 11 F 13 F 16 F 19 F 22 F 27 F 32**

(available apertures limited to those of lens in use.)

- Intermediate figures (e.g. **F 1.8**, **F 3.3**) indicate the maximum aperture of lens in use. With zoom lenses, the maximum aperture for each of the various focal length settings is shown in 1/6 EV steps.

If exposure meter and LCD indications automatically turn off, turn them on again by lightly pressing the shutter release button.

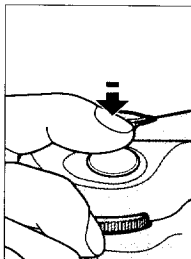

**3** Look inside viewfinder, compose shot and lightly press the shutter release button. Confirm focus and the automatically set shutter speed.

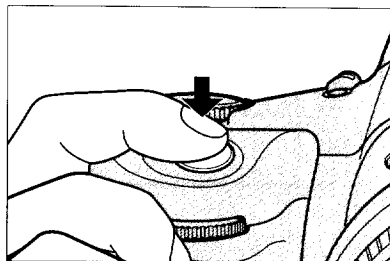

**4** To take picture, fully depress shutter release button.

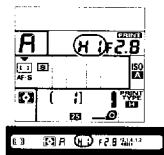

If **H** appears with electronic analog display\*—Overexposure alert  
Select a smaller aperture (larger f-number) or use ND filter.

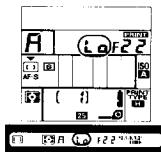

If **L** appears with electronic analog display\*—Underexposure alert  
Select a wider aperture (smaller f-number) or use built-in flash or a Nikon Speedlight.

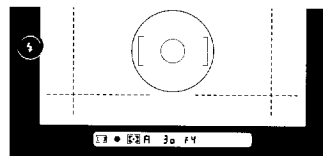

If green **⚡** appears—Flash photography is recommended  
Use built-in flash or a Nikon Speedlight.

\* Shows difference in value from correct exposure. If difference exceeds  $\pm 2EV$ ,  
▶ appears for underexposure, ◀ for overexposure.



## OPERATION IN MANUAL EXPOSURE MODE

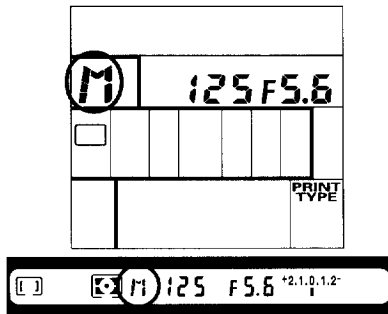
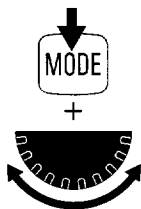

1 While pressing **MODE** button, rotate Main-Command Dial until **M** for **MANUAL** appears in the LCD panel (and viewfinder).

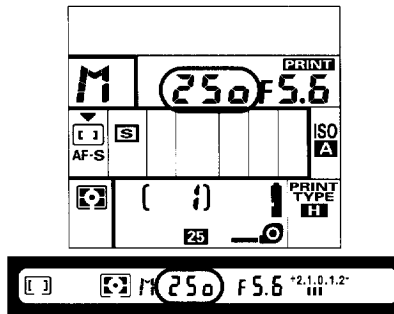

2 Remove finger from **MODE** button and rotate Main-Command Dial to set your desired shutter speed. (For shutter speed indications and sequence, see page 53.)

- In Manual exposure mode, you can set the shutter speed to **bulb** for long time exposures. For details on long time exposure, see pages 102-103.

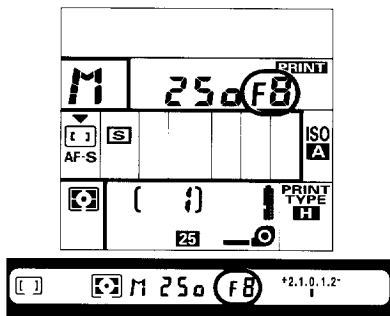

- 3 Rotate Sub-Command Dial to set desired aperture.  
(For aperture indications and sequence, see page 55.)

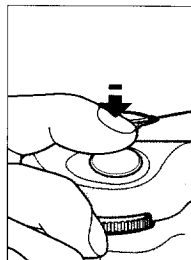

- 4 Look inside viewfinder, compose shot and lightly press the shutter release button. Adjust shutter speed and/or aperture by rotating Main- and Sub-Command Dials until the electronic analog display shows "0" or your desired amount. Be sure to confirm focus.

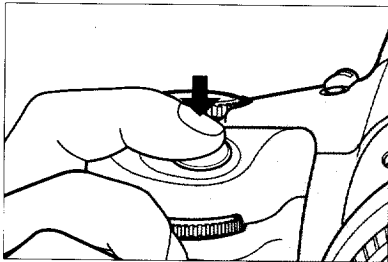

5 To take picture, fully depress shutter release button.

### Electronic analog display examples

+2.1.0.1.2-



Over +2 EV

+2.1.0.1.2-



±0 EV

+2.1.0.1.2-



+1 EV

+2.1.0.1.2-



-1 EV

+2.1.0.1.2-



Under -2 EV

Electronic analog display blinks when the subject is too dark for metering. In this case, use built-in flash or a Nikon Speedlight.

# METERING SYSTEM

---

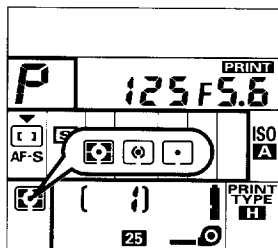
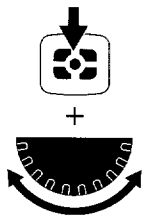

The Nikon Pronea 6i features three types of exposure metering systems—3D Matrix Metering, Center-Weighted Metering and Spot Metering.

While pressing button, rotate the Main-Command Dial to set for 3D Matrix Metering, for Center-Weighted Metering or for Spot Metering.

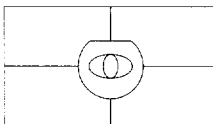

### 3D Matrix Metering

This system is ideal for quick operation in any exposure mode (pages 46 to 59). With IX-Nikkor lenses or D-type AF Nikkor lenses, 3D Matrix Metering is automatically activated. 3D Matrix Metering uses three types of data: (1) scene brightness, (2) scene contrast and (3) distance to focused subject (Distance Information). Data on scene brightness and contrast are detected by the camera's eight-segment Advanced Matrix Sensor, while data on the distance to focused subject is detected and relayed by the D-type AF Nikkor lens in use. Information sent by the camera's autofocus system indicating

whether the main subject is centered is also considered in the computation. Through analyzing these data, the Pronea 6i's built-in microcomputer is able to provide correct exposures even in extremely complex lighting situations. If a non-D-type AF Nikkor lens or AI-P-Nikkor lens is used, Advanced Matrix Metering is performed. Although the lens does not provide Distance Information, the eight-segment Advanced Matrix Sensor provides a correct exposure in most lighting situations.

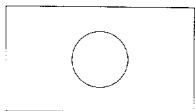

### Center-Weighted Metering

With approx. 65% of the meter's sensitivity concentrated on the 8.4mm-diameter circle in the viewfinder and approx. 35% outside this circle, this meter proves useful in situations where you want to base your exposure on a specific area in the scene. In auto exposure mode, to measure the brightness of the picture's off-center portion, use the AE-L button (pages 90 to 91).



### Spot Metering

Nearly 100% of the meter's sensitivity is concentrated on the 2.5 mm-diameter circle (approx. 1% of entire frame) in the center of the viewfinder. Use this meter for extra-selective exposure control; experience is required to achieve optimum results.

## AF MODE AND FOCUS AREA

### SELECTING AF MODE AND FOCUS AREA

The Nikon Pronea 6i features two autofocus modes, Single Servo AF (**AF-S**) and Continuous Servo AF (**AF-C**), and the autofocus system offers a choice of two focus areas, Wide (□) and Spot (□).

AF mode and focus area are set simultaneously.

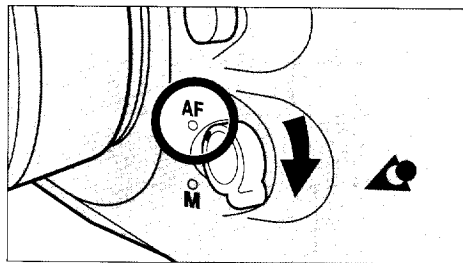

- 1 For autofocus, set the focus mode selector at AF.

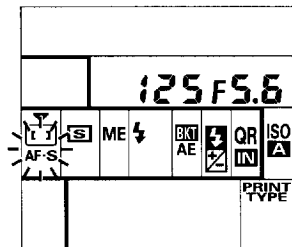
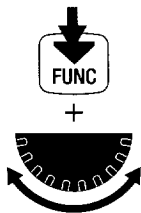

- 2 Hold **FUNC** button and rotate Main-Command Dial until the function set indicator (▼) appears in the focus area/AF mode area and the symbol within this area starts blinking. Remove finger from **FUNC** button and confirm that symbol within this area has stopped blinking.

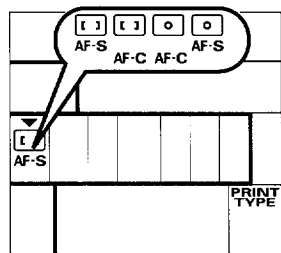
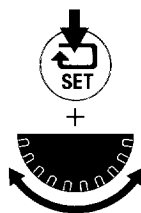

- 3 Hold **SET** button and rotate Main-Command Dial until your desired combination appears.

#### For flash photography

When built-in flash is activated or attached Nikon Speedlight turned on, Wide Area automatically switches to Spot Area, [ ] blinks in LCD panel and [ ] appears inside viewfinder.



---

## AF Mode



### AF-S Single Servo AF

Lightly pressing the shutter release button activates the lens focus adjustment. Because the priority is on correct focus, the shutter locks until a stationary subject is in focus (showing ●) or until the camera anticipates a moving subject to be in focus. After focus is achieved with a stationary subject, the focus remains locked for as long as the shutter release button is lightly pressed. This feature proves especially useful when recomposing a picture with the main subject off center (pages 69 to 70). If the camera-to-subject distance changes, however, you must refocus.



### AF-C Continuous Servo AF

Under certain conditions, such as very fast action situations, you may want to take a picture even before focus is successfully achieved. In such cases, use Continuous Servo AF. In Continuous Servo AF mode, as you lightly press shutter release button, focus detection begins and the lens continues focusing for as long as you keep the shutter release button lightly pressed. Since the priority is on shutter release, you can fully depress the shutter release button regardless of focus status.

## Focus Area



### Wide Area AF

The Wide-Area focus brackets delineate the focus detecting area in the viewfinder. Subjects of sufficient brightness and detail can be detected within these brackets. In addition to general photography, autofocus with Wide-Area focus brackets is suitable for action photography where the moving subject requires a wide-range focus detection area.



### Spot Area AF

Spot Area AF, in which the focus detecting area is designated by the 2.5mm-diameter circle at the center of the viewfinder, is recommended in the following situations:

- a. Subject is considerably smaller than the wide-area focus brackets\*
- b. Subject is obscured by an object, such as a fence, in the foreground
- c. A particular portion of a subject—such as the eyes—must be in focus in a portrait
- d. For a strongly backlit subject, such as someone standing beside bright window\*\*

\* Lock focus. See "AUTOFOCUS WITH MAIN SUBJECT OFF CENTER", pages 69 to 70.

\*\* To ensure subject is correctly exposed, see "AUTO EXPOSURE LOCK FUNCTION WITH AE-L BUTTON", pages 90 to 91.

## SINGLE SERVO AF OPERATION



### **With stationary subject**

Lightly press the shutter release button. While autofocusing, ◀ or ▶ (for front or rear focus) may appear. When the subject is in focus, the lens stops moving, the in-focus indication ● appears in the viewfinder, and the focus locks. If the subject moves, remove your finger from the shutter release button, then lightly press again to restart autofocus.

---

### With moving subject

Lightly press the shutter release button to automatically activate Focus Tracking. Confirm ● appears in the viewfinder, then fully depress shutter release button. (The shutter release button can in fact be depressed without confirming ● indication; as soon as the subject comes into focus, the shutter will be released.) Focus Tracking remains active as long as you keep the shutter release button lightly pressed. If the subject stops and ● appears, the focus is locked. If the subject moves again, remove your finger from the shutter release button and lightly press again to start autofocus with Focus Tracking.

#### If ◀ stays in the viewfinder

Subject is located closer than the closest focusing distance of the lens. Move away from subject and refocus.

#### If ▶ ◀ blinks in the viewfinder

Autofocus is not possible (see page 109) and shutter locks.

Single Servo AF is convenient for off-center subjects. See page 69 to 70.

## AUTOFOCUS WITH MAIN SUBJECT OFF-CENTER

As previously noted, in Single Servo AF, the focus remains locked as long as the shutter release button is kept lightly pressed. Use this feature for shooting off-center subjects.

- In the following procedures, Spot-Area AF and Spot Metering are used for demonstration photos.

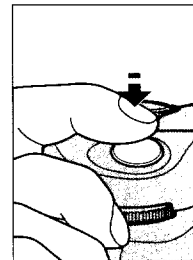
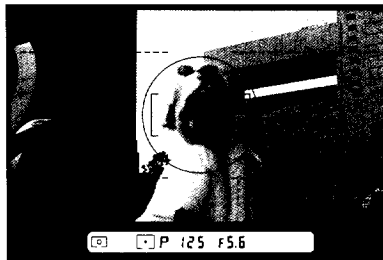

- 1 Center main subject inside the viewfinder and lightly press the shutter release button to start Single Servo AF operation.

- If there is substantial difference in the brightness of the subject and background, switch metering to Center-Weighted or Spot and use the Auto Exposure Lock function (pages 90 to 91).
- With a moving subject, the focus cannot be locked.



2 Confirm in-focus indicator ● appears in the viewfinder.

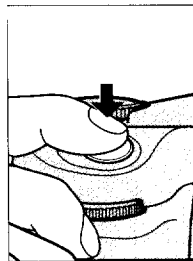

3 While lightly pressing the shutter release button, recompose as desired, then fully depress the shutter release button to take the picture.

- When recomposing, do not change the camera-to-subject distance.

## CONTINUOUS SERVO AF OPERATION

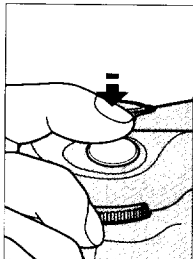

### With a stationary subject

Lightly press shutter release button to start autofocus operation. During autofocusing, ◀ or ▶ (for front or rear focus) may appear. When the subject is in focus, the camera's autofocus motor stops driving the autofocus lens and ● appears in the viewfinder.

Unless you remove your finger from shutter release button, the motor will start driving the lens again to obtain an in-focus picture if the subject moves.

#### If ◀ stays in the viewfinder

Subject is located closer than the closest focusing distance of the lens. Move away from subject and refocus.

#### If ▶ ◀ blinks in the viewfinder

Autofocus is not possible (see page 109).



### With a moving subject

Lightly press shutter release button and Focus Tracking is automatically activated. Confirm ● appears in the viewfinder, then fully depress shutter release button. As Focus Tracking remains activated as long as you keep lightly pressing the shutter release button, you do not have to refocus if the subject stops.

As focus is not locked in Continuous Servo AF, to take an off-center subject, select Single Servo AF. (Pages 67 to 68.)

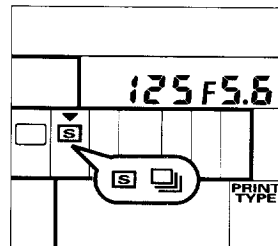
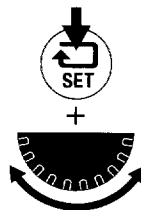
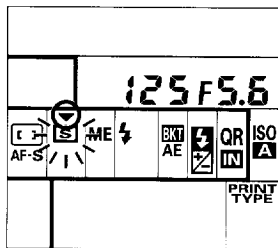
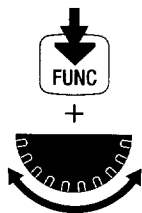
## FILM ADVANCE MODE



There are two automatic film advance modes. Hold **FUNC** button and rotate Main-Command Dial until function set indicator (▼) appears in the film advance mode area and symbol in the area (S or ) starts blinking. Remove finger from **FUNC** button and confirm that symbol in the area stops blinking. Then hold **SET** button and rotate Main-Command Dial to set S for single-frame shooting or  for continuous shooting.

### With built-in flash

When built-in flash is activated, continuous shooting is automatically switched over to single-frame shooting. In this case,  blinks in LCD panel.



---

### **Single-frame shooting**

Fully depressing shutter release button takes one picture and automatically advances film by one frame. Film is advanced immediately after shutter closes whether you remove your finger from shutter release button or keep the button depressed. To take the next shot, lift your finger from the button, then fully depress it again.

### **Continuous shooting**

Shots are taken continuously as long as you keep shutter release button fully depressed, with shooting speed of approx. 3.5 fps (frames per second)\*. For Focus Tracking, shooting speed is approx. 3.3 fps.

*\* With fresh lithium batteries at normal temperature (20°C or 68°F) and at shutter speeds of 1/250 sec. or higher in Manual exposure and Continuous Servo AF modes.*

## TWO-BUTTON RESET

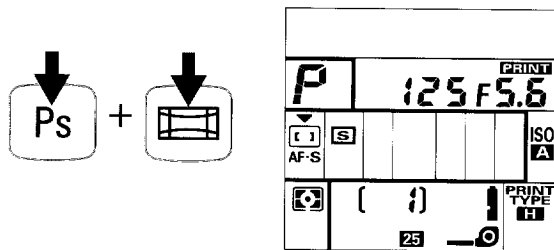

Press and hold the two green buttons, (Ps and ) for more than two seconds.

The camera's settings are automatically reset to factory initial settings as shown below:

Exposure mode:	Auto-Multi Program (P)
Metering system:	3D Matrix (E)
Focus area:	Wide (□)
AF mode:	Single Servo AF (AF-S)
Film advance mode:	Single-frame (S)
Flash sync mode:	Normal*
Number of prints:	1
Exposure compensation:	Cancel
Flexible Program:	Cancel
Auto Exposure Bracketing:	Cancel
Flash Exposure Bracketing:	Cancel
Multiple Exposure:	Cancel
Self-timer:	Cancel

\* With a built-in flash or accessory Nikon Speedlight turned on,  appears for normal sync. If an accessory Nikon Speedlight attached is set at Rear-Curtain Sync, Rear-Curtain Sync will be performed.

For details about each function/mode, see following pages:

- Exposure mode: pp. 46-59
- Metering system: pp. 60-62
- Focus area: p. 66
- AF mode: p. 65
- Film advance mode: pp. 72-73
- Flash sync mode: pp. 114-116
- Number of prints: p. 78
- Exposure compensation: pp. 94-95
- Flexible Program: pp. 51-52
- Auto Exposure Bracketing: pp. 96-98
- Flash Exposure Bracketing: pp. 123-125
- Multiple exposures: pp. 99-101
- Self-timer: p. 88



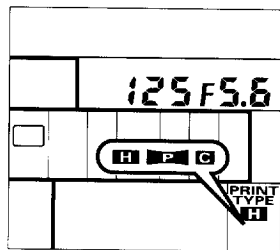
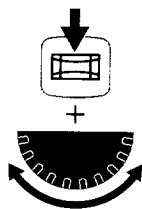

# **ADVANCED PHOTO SYSTEM FUNCTIONS**

This section shows Advanced Photo System features.

# PRINT TYPE



You can select any one of three print types—wide-vision (H), panorama (P) or classic (C)—at any time.

While pressing  button, rotate Main-Command Dial to set  for wide-vision type,  for panorama type or  for classic type.

- Once set, print type is maintained even after shutter is released or camera's power is off.

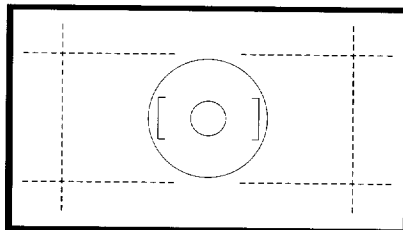

## Wide-vision (H) type

Vertical vs. horizontal = 9:16 (aspect ratio)

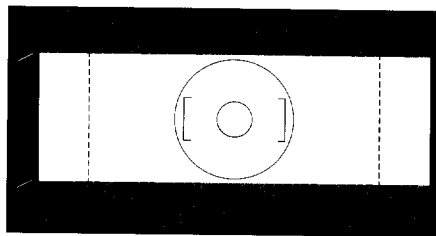

## Panorama (P) type

Vertical vs. horizontal = 1:3 (aspect ratio)

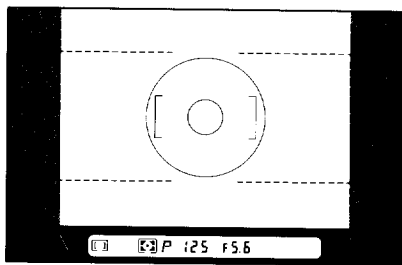

## Classic (C) type

Vertical vs. horizontal = 2:3 (aspect ratio)



Wide-vision type



Classic type



Panorama type

## PRINT QUANTITY

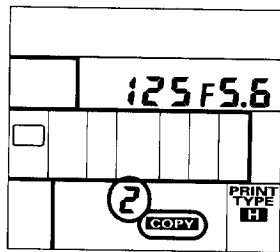
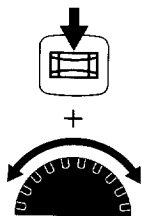

You can set print quantity from 2 to 7 for the next unexposed frame. (As factory initial setting, print quantity is set to 1 for one copy.)

While pressing  button, rotate Sub-Command Dial until desired number for print appears in place of frame counter.

When you set print quantity to 2 or more, **COPY** appears in LCD panel.

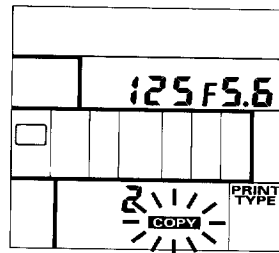

After shutter is released, print quantity is reset to 1.

- You cannot set print quantity for exposed frame.
- Print quantity you set is maintained after the exposure meter automatically turns off.
- Turning the camera's power off resets print quantity to 1.



### To reset print quantity to 1 or 0 immediately for the shot just you have taken

Immediately after the shot is taken, you can reset print quantity to "1" or set print quantity to 0 for print cancel.

Press  and  buttons simultaneously for more than two seconds until **COPY** stops blinking and print quantity indication resets to "1".

To set print quantity to 0 for print cancel, remove your finger from two buttons then press them again until "0" appears.

## MID-ROLL CHANGE

---

You can rewind film before it reaches its end of roll and use the partially exposed film again for this camera. (Do not install the partially exposed film in a camera other than Pronea 6i. Once installed in camera other than Pronea 6i, the film cannot be used.)

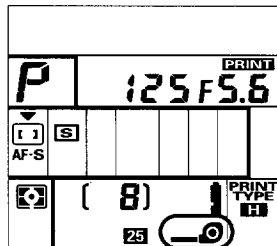
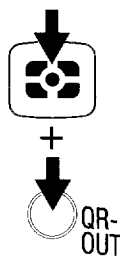

- 1 Press  and **QR-OUT** buttons for two seconds or longer. Film starts rewinding,  appears in the LCD panel, and frame counter counts backwards until rewind is completed.

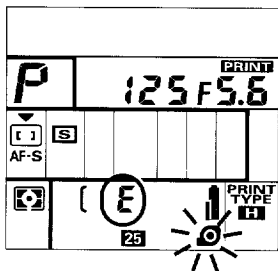

**2** Confirm the frame counter shows **E** and film installation symbol  blinks indicating that film rewind is completed.

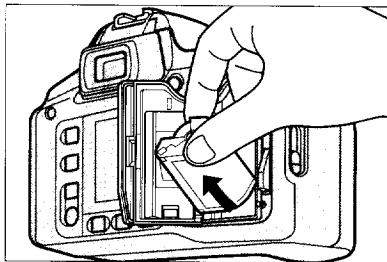

**3** Open film cartridge chamber cover and remove film cartridge.

- Unless film rewind has been completed, the film cartridge chamber cover is locked. Do not attempt to forcibly open the cover.
- To conserve battery power, remove film cartridge immediately after film rewind is completed.

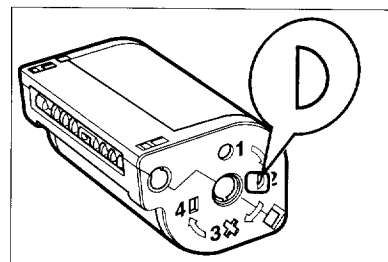

### Using partially exposed film

Confirm that the Visual Exposure Indication shows **D**.

When a partially exposed film is installed, the camera automatically advances the film to the frame next to the last exposed frame and frame counter shows the corresponding number.

(For installing film, see pages 28 to 31.)



## DATA RECORDING AND DATA PRINTING

---

Advanced Photo System lets various data recorded on the magnetic track on the film. This is called Information Exchange (IX).

Some recorded data is used to compensate the exposure for better results when making prints.

Some recorded data can be printed on pictures for your reference.

Note that ***data printing service is available only at certified photofinishers***. When ordering prints, ask your photofinisher if they can handle data printing.

### For front print

Six types of date/time display are available and you can select one for printing. (See page 82)

### For back print

Data backprinting is always performed. For back print, the following data is recorded;

date and time	title
focal length*	maximum aperture*
ISO film speed (set speed)	aperture in use
shutter speed in use	exposure compensation value
metering system	print quantity
magnification ratio	print type
flash used or not	brightness value

As maximum number of characters to be printed is limited, not all data recorded can be printed.

Style and location of back print depend on photofinishers.

\* *When title is set, focal length and maximum aperture recorded are ignored and will not be printed.*



## PRINTING DISPLAYED DATE/TIME

As previously mentioned, the date/time data you have selected from the six available types is always backprinted and can also be frontprinted if desired. Available types of date/time data are:

Order of date	Date/time displayed	PRINT symbol	Data to be imprinted	
			Front print	Back print
Year/Month/Day	Year/Month/Day	Appears	Year/Month/Day	Year/Month/Day
Year/Month/Day and Hour/Minute	Year/Month/Day and Hour/Minute	Appears	Year/Month/Day and Hour/Minute	Year/Month/Day and Hour/Minute
No print	- - - - -	Disappears	No print	

You can print date only or both date and time. For date, you can change the order of year, month and day (i.e., Year/Month/Day, Month/Day/Year or Day/Month/Year).

### To select Date Only, Date & Time or Print Cancel display

Turn the camera off, then press  button twice to change display. Remove finger from  button, then press again to change the display. As you continue pressing  button, the display changes as follows:

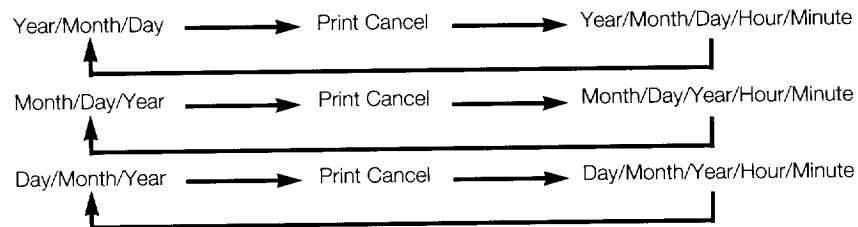

---

### To change the order of year, month and day

Turn the camera power off. Confirm that **PRINT** appears in LCD panel. If not, press **PRINT** button to make **PRINT** appear. Then press and hold **PRINT** button more than four seconds until the display changes. For further change, remove finger from **PRINT** button then press again. The display changes as follows:

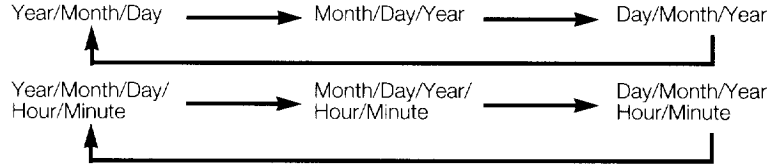

When **PRINT** does not show in the LCD panel, backprinting of date or date/time are always performed.

## SETTING TITLE

---

The Pronea 6i offers imprinting of titles on prints in 12 languages.  
Language number 12 is selected at initial factory setting.

### Languages provided

Language No.	Language
LC 01	Danish
LC 02	Finnish
LC 03	French
LC 04	German
LC 05	Italian
LC 06	Japanese
LC 07	—
LC 08	Norwegian
LC 09	Portuguese
LC 10	Swedish
LC 11	Spanish
LC 12	British English
LC 13	American English



**Titles provided (for language No. 13)**

Title number	Title
--	no title
00	Christmas
01	Birthday
02	Vacation
03	Honeymoon
04	Wedding
05	Hanukkah
06	Graduation
07	Family
08	Party
09	Holiday
10	Anniversary
11	Friends
12	School Event
13	Trip
14	I Love You
15	Thank You
16	Season's Greetings
17	Happy Birthday
18	Congratulations
19	Merry Christmas
20	Festival
21	First day of School
22	Tour
23	New Year's
24	Easter

Title number	Title
25	Happy New Year
26	Reunion
27	Father's Day
28	Mother's Day
29	Memories
30	Baptism
50	Halloween
51	Happy Holiday
52	Independence Day
53	Thanksgiving
54	Rosh Hashanah
55	Yom Kippur
56	Memorial Day
57	Labor Day
58	Valentine's Day
59	Canada Day
60	Victoria Day
61	Remembrance Day
62	—
63	—
64	—
65	—
66	—
67	—
68	—

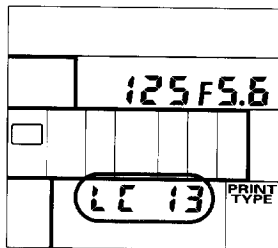
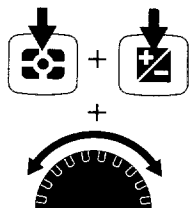
Title number	Title
69	—
70	—
71	—
72	—
73	—
74	—
75	—
76	—
77	—
78	—
79	—
80	—
81	—
82	—
83	—
84	—
85	—
86	—
87	—
88	—
89	—



- 1 While pressing both  and  buttons, rotate Sub-Command Dial until desired language number appears with "LC".

You can change language anytime. Note that language you set last is used for all frames (including exposed frame). Two or more languages cannot be used for one roll.

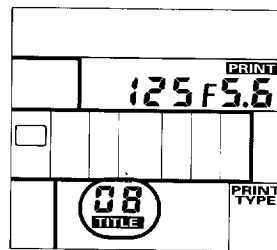
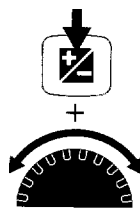

- 2 While pressing  button, rotate Sub-Command Dial until your desired title number appears.

After removing finger from  button, the frame counter replaces the title number, but **TITLE** appears in the LCD panel indicating the title you set will be imprinted.

The title you set will be maintained until cancelled or another title is set.

#### To confirm language

Press  and  buttons.

#### To confirm selected title number

In BASIC mode: With **TITLE** showing in the LCD panel, press  button.

In ADVANCED mode: With **TITLE** showing in the LCD panel, while pressing  button, rotate Sub-Command Dial one click-stop.

#### To cancel title

While pressing  button, rotate Sub-Command Dial until -- takes the place of the title number.



Remove finger from  button and confirm that **TITLE** disappears.

# **SPECIAL FUNCTIONS**

This section explains sophisticated photographic techniques and applications: self-timer operation, exposure compensation, multiple exposure and long time exposures. It also shows QR (Quick Recall) function and how to manually set the film speed, how to focus manually, and what you should do in special focusing situation.

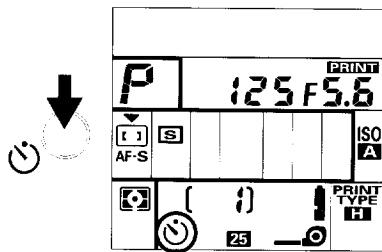
## SELF-TIMER OPERATION



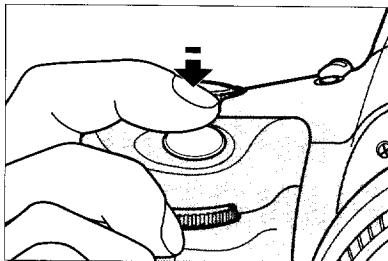

**1** Press self-timer  button and confirm that  appears in LCD panel.

- To cancel the self-timer before self-timer operation, press and hold **P**s and  buttons for more than two seconds for Two-Button Reset, or turn camera's power off.

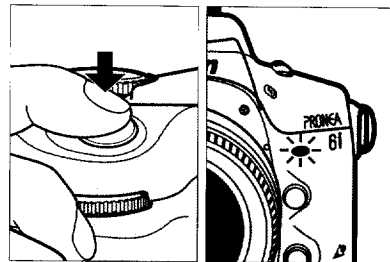

**2** Look through the viewfinder, then lightly press the shutter release button and confirm focus and exposure.



**3** Fully depress the shutter release button. The self-timer LED starts blinking, and the shutter will release after 10 seconds. The self-timer LED blinks for eight seconds, then stops blinking to signal you to prepare for the shot. After shooting, the self-timer is canceled and  disappears.

- To cancel self-timer during operation, turn the camera off.

- When using any Auto exposure mode, attach the eyepiece cover (provided) to the viewfinder eyepiece before setting the self-timer. The eyepiece cover prevents stray light from entering the viewfinder and affecting the exposure.
- In Single Servo AF mode, the self-timer operates only when the in-focus indicator (●) appears inside the viewfinder. After self-timer operation starts, however, the shutter will be released even if the subject is out of focus.
- During self-timer operation, autofocus will not start even if you lightly press shutter release button.
- Regardless of film advance mode setting, continuous shooting is not performed.
- At **bulb** setting, shutter speed is controlled at approx. 1/30 sec.



# EXPOSURE COMPENSATION

## ABOUT EXPOSURE COMPENSATION

Exposure compensation is a photographic technique that enables you to vary the final exposure settings from those measured by the camera's light meter. Nikon's 3D Matrix Metering employs exposure calculation methods that automatically apply exposure compensation based on scene brightness/contrast and distance information. As a result, your subject, whether centered in the viewfinder or not, is given a corrected exposure in most lighting situations.

We do not recommend manually or automatically applying exposure compensation when using Matrix Metering. If you identify an extreme condition where using Matrix Metering may prove difficult, such as a severely backlit scene or one with extremes of contrast, we recommend using your camera's other built-in meters, Center-Weighted or Spot. Ultimately, only you know what the subject or a part of it requires in terms of exposure measurement. That's why the Pronea 6i camera incorporates three meters plus a variety of exposure compensation systems. The photographer's creativity is always the final deciding and controlling factor. To use the various exposure compensation functions, please refer to the following:

- Using auto exposure lock function with AE-L button (pages 90 to 91)
- Obtaining meter reading for a particular subject in Manual exposure mode (pages 57 to 59)
- Modifying exposure control with exposure compensation function (pages 94 to 95)
- Auto Exposure Bracketing (pages 96 to 98)

Results will vary, depending on conditions, so you will want to experiment with each method.

### About reflectance

When using the Center-Weighted or Spot Meter, always keep in mind that the exposure indicated will assume that the subject's reflectance is equivalent to 18%. If the subject varies from this reflectance, you must make an adjustment to exposure. Generally speaking, a white subject will have about a 90% reflectance, and opening a further 2.5 f/stops will bring the exposure back to the equivalent of an 18% reading. Another rule of thumb is that when shooting a landscape, the light meter reading from green grass is roughly equivalent to 18% reflectance.

## AUTO EXPOSURE LOCK FUNCTION WITH AE-L BUTTON

In auto exposure mode, when you want to control exposure based on the brightness of a specific area within the scene, use Auto Exposure Lock function. In order to use the Auto Exposure Lock function, however, you should first switch to Center-Weighted or Spot Metering.



**1** Center the main subject inside the viewfinder and/or move in closer until the subject fully covers the reference circle for Center-Weighted or Spot Metering.

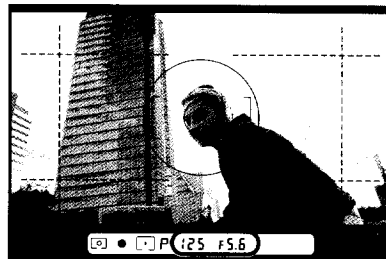
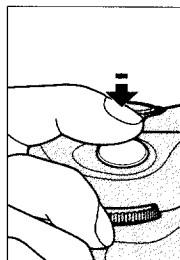

**2** Lightly press the shutter release button, and confirm shutter speed and aperture in viewfinder.

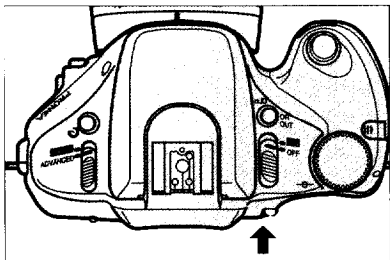

3 Push AE-L button and hold in to lock auto exposure.

- While holding the AE-L button, the flash recommended light (green ) does not light up.

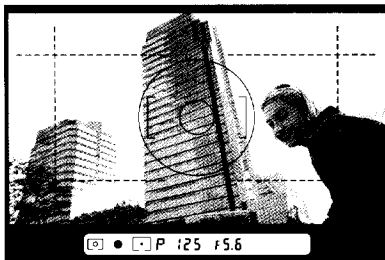

4 While holding the AE-L button, recompose picture, focus again and shoot.

- In Single Servo AF mode, if recomposing the picture may have changed the subject-to-camera distance, refocus by briefly removing your finger from the shutter release button and then lightly pressing again.
- Continuous Servo AF is not recommended if the subject will move off-center after recomposing with AE-lock.

---

## TO OBTAIN METER READING FOR A PARTICULAR SUBJECT IN MANUAL EXPOSURE MODE

In Manual exposure mode, to give a particular subject your desired exposure, switch to Center-Weighted or Spot Metering system then use the following procedure:

For Manual Exposure operation, see pages 57 to 59.

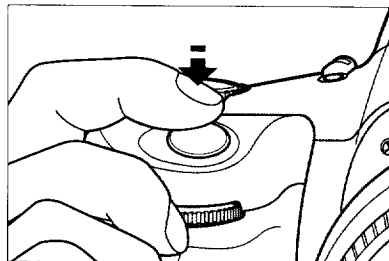

2 Lightly press shutter release button.

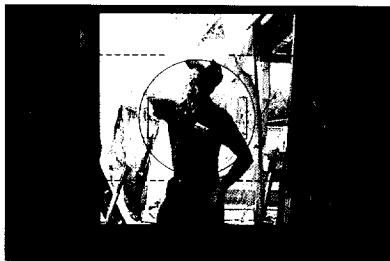

1 Center main subject inside viewfinder and, if necessary, move closer until the subject fully covers the reference circle for Center-Weighted or Spot Metering.

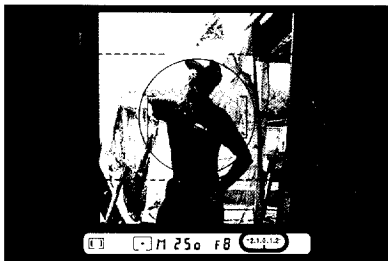

3 Adjust shutter speed and aperture until electronic analog display shows desired exposure.



4 Recompose picture and shoot.

- In Single Servo AF mode, if recomposing the picture could change subject-to-camera distance, refocus by briefly removing your finger from shutter release button and then lightly pressing it
- Continuous Servo AF is not recommended if the subject becomes off-center after recomposing with AE-lock.

## EXPOSURE COMPENSATION FUNCTION

The exposure compensation function lets you modify exposure control (i.e., from the ISO standard) in 1/2 steps from -5EV to +5EV. With a too bright background, compensate in the + direction; with a too dark background, compensate in the - direction. In flash photography, the flash output level is also compensated. After taking your photographs, be sure to reset the control to "0" to resume normal operation.

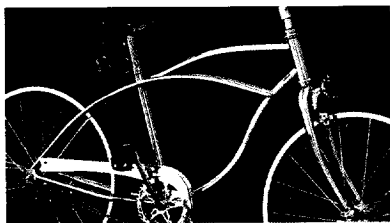

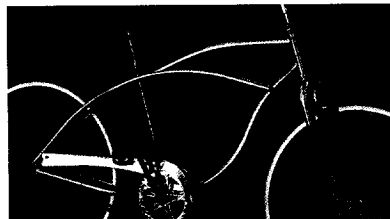

Without compensation



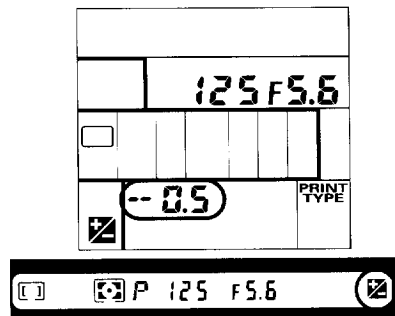
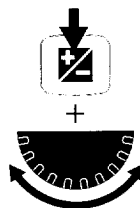

With compensation

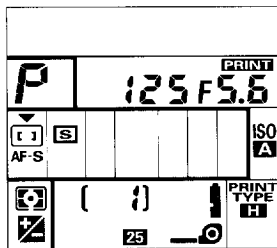

- 1 While pressing  button, rotate Main-Command Dial until desired compensation value appears in the frame counter area of the LCD panel.  symbol also appears in the LCD panel and inside viewfinder.  
(The example above shows a -1/2 compensation setting.)



- 2 Once set, exposure compensation remains fixed until reset. Although  remains in the LCD panel to indicate exposure compensation is on, the compensation value disappears from the readout when you remove your finger from  button. ( disappears from inside the viewfinder when the exposure meter automatically turns off.)

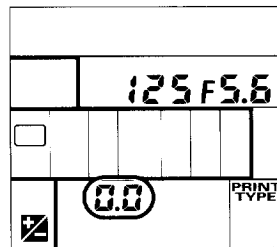
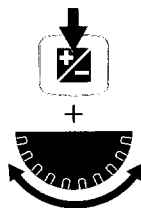

- 3 After shooting, be sure to reset the compensation amount to "0" to resume normal operation.
- You can also cancel exposure compensation by pressing and holding **P**s and  buttons for more than two seconds (Two-Button Reset).

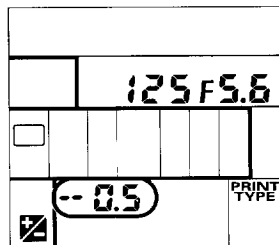
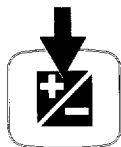

To confirm the compensation value on the LCD panel, press  button.

## AUTO EXPOSURE BRACKETING

In situations where you might find it difficult to obtain a proper exposure, Auto Exposure Bracketing lets you shoot the same subject at three different exposures, using a varying exposure compensation degree of 0.5 EV or 1 EV.

Setting a compensation degree of 0.5 EV, for example, lets you take three pictures: the first with no compensation, the second shot with a  $-0.5$  EV compensation and the third with a compensation of  $+0.5$  EV.

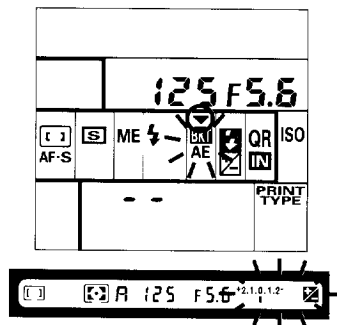
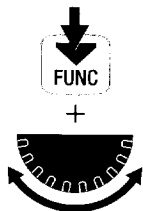

1 Hold **FUNC** button and rotate Main-Command Dial until function set indicator ( $\blacktriangledown$ ) appears in the Auto Exposure/Flash Exposure Bracketing area and **AE** and **AE** start blinking. Removing finger from **FUNC** button causes **AE** and **AE** to stop blinking in LCD panel. Electronic analog display starts blinking inside viewfinder.

- When "bulb" is set, setting Auto Exposure Bracketing locks the shutter and makes **bulb** indication blink in the LCD panel and viewfinder.
- Auto Exposure Bracketing and Flash Exposure Bracketing cannot be set simultaneously. Setting one cancels the other.



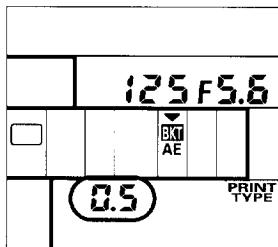
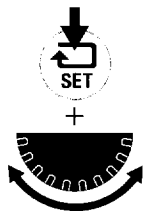

- 2 Hold **SET** button and rotate Main-Command Dial until your desired compensation degree (**0.5** or **1.0**) appears.

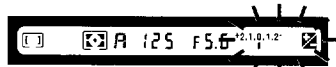
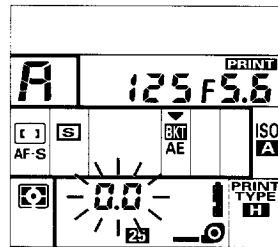

- 3 Remove finger from **SET** button to complete setting. **0.0** starts blinking in LCD panel to indicate no compensation. Electronic analog display starts blinking inside viewfinder.
- To cancel Auto Exposure Bracketing before starting or during bracketing, turn the camera power off then on again, or press and hold **P<sub>s</sub>** and **[ ]** buttons for more than two seconds for Two-Button Reset.

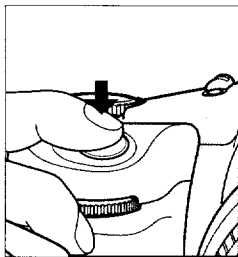

First shot is taken.

Second shot is taken.

Third shot is taken.

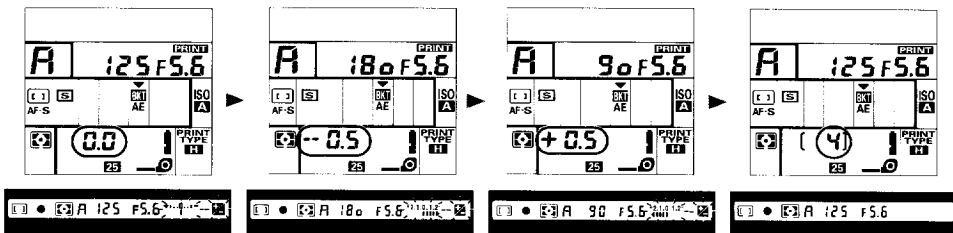

**4** Compose picture, confirm focus and exposure, then fully depress shutter release button.

**In single-frame shooting (S):** Fully depress shutter release button three times to take the three shots.

**In continuous shooting (C):** Fully depress shutter release button and hold in until three shots are taken. (Film advance automatically stops when three shots are taken.)

After three shots are taken, Auto Exposure Bracketting is automatically canceled.

- In Programmed Auto exposure mode, shutter speed and aperture vary.
- In Shutter-Priority Auto exposure mode, aperture varies.
- In Aperture-Priority Auto and Manual exposure modes, shutter speed varies.
- When using Auto Exposure Bracketting with the Exposure Compensation function, the compensated value will be added. If an exposure is compensated at +1 EV and you set Auto Exposure Bracketting at 0.5 EV, for example, the first shot will be taken with +1 EV compensation, the second shot with +0.5 EV compensation and the third shot with +1.5 EV compensation.
- In flash shooting, Auto Exposure Bracketting compensates background exposure, but does not affect the flash output level.
- If you reach the end of the film roll during shooting, the film automatically starts rewinding. If this happens, after rewinding is complete, replace the film cartridge with a new one, then fully depress the shutter release button again to resume operation.

## MULTIPLE EXPOSURES

Lets you take a picture of two or more different subjects or two or more pictures of the same subject on one frame.

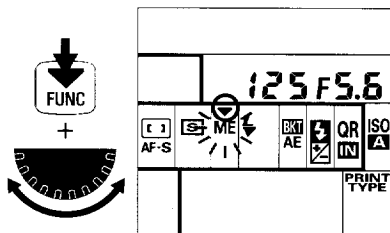

1 Hold **FUNC** button and rotate Main-Command Dial until function set indicator (▼) appears in the multiple exposures area and **ME** starts blinking.

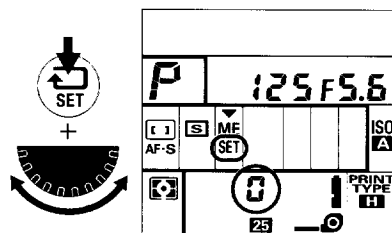

2 Hold **SET** button and rotate Main-Command Dial until **SET** appears below **ME**. Each time you rotate the Main-Command Dial by one click, **SET** appears then disappears. Remove your finger from **SET** button and confirm the number in the frame counter area shows the number of exposures. (☐ appears before you take the multiple exposures.)

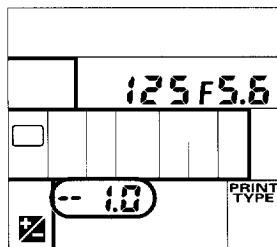

### 3 Compensate exposure.

As a frame is exposed twice or more, each of the exposures in the multiple exposure should be compensated.

Use the table below for your reference:

(For Exposure Compensation, see pages 94 to 95.)

Number of exposures	Compensation degree
2	-1.0
3	-1.5
4	-2.0
8 - 9	-3.0

*The amount of compensation required depends on the situation in each scene. Test shots are recommended.*

*With several shots of the same subject against a black background, each shot should be taken with a correct exposure.*

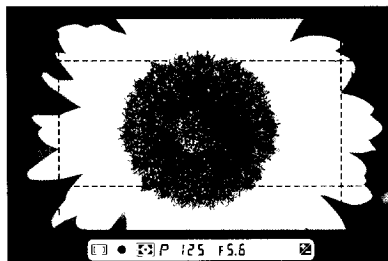

- 4 Look through viewfinder, compose picture, then lightly press shutter release button and confirm focus/exposure. Fully depress shutter release button to take the first exposure. (For three or more exposure shots, set film advance mode to **LS** for single-frame shooting.) **SET** disappears and **↑** (for first exposure) appears in the frame counter area.

---

### For a two-exposure picture:

After the first exposure, fully depress the shutter release button again. Film automatically advances and Multiple Exposure function is canceled.

### For a three-or-more-exposure picture:

Before fully depressing the shutter release button for the next exposure, set the Multiple Exposure function again (following steps 1 and 2).

The frame count number increases every time a frame is exposed.

- The indicator for the number of multiple exposures taken increases to “19”, and remains at “19” even if twenty or more exposures are taken.

### To cancel multiple exposure operation before releasing shutter

Hold **SET** button and rotate Main-Command Dial one click so **SET** below **ME** disappears.

### To cancel next exposure

Turn the camera off, press and hold **Ps** and **[ ]** buttons to perform Two-Button Reset or switch the camera mode to BASIC.

- With film advance mode at **[ ]** for continuous shooting, fully depressing the shutter release button will activate a double-exposure shooting then cancel the multiple exposure function.
- Film dislocation may occur due to film curling, especially for the first and last frames of the roll.

## LONG TIME EXPOSURE USING *bulb* SETTING

At *bulb* setting, the shutter remains open for as long as the shutter release button remains depressed.

To avoid camera shake, which may cause picture blur, use a tripod.

Use of Nikon Cable Release AR-3, which features a shutter release button, is also recommended to avoid camera shake.

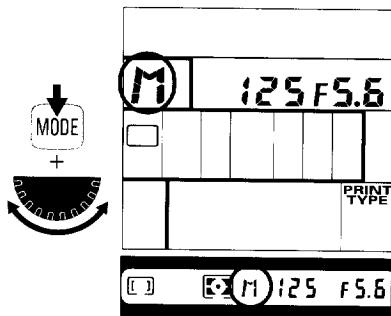

1 While pressing **MODE** button, rotate the Main-Command Dial until **M** for Manual exposure mode appears in the LCD panel and viewfinder.

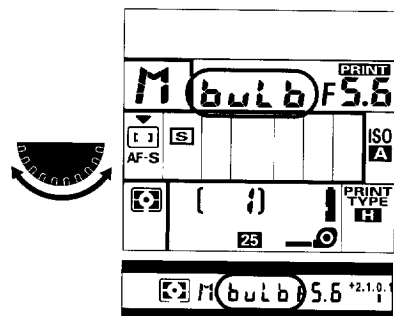

2 Remove finger from **MODE** button and rotate Main-Command Dial until **bulb** appears in the LCD panel and viewfinder.

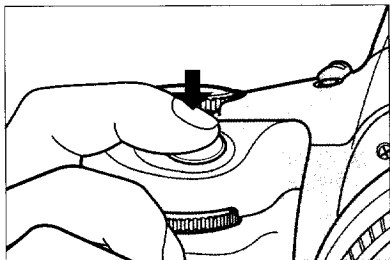

3 Fully depress shutter release button and hold as long as desired.

Long time exposures can be performed for approximately 4 hours with a fresh battery set at normal temperatures. At lower temperatures, the maximum duration for a long time exposure will be shorter.

## QR (QUICK RECALL) FUNCTION

Settings for exposure mode (including Vari-Program), metering system, focus area/AF mode, film advance mode, flash sync mode, multiple exposure, exposure compensation function, flash output level compensation, and Auto Exposure/Flash Exposure Bracketing can be memorized in the Pronea 6i's microcomputer for easy recall. Three numbers (1 to 3) are provided for custom settings.

### TO MEMORIZE

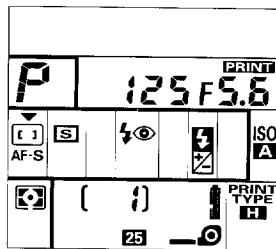

- 1 Confirm exposure mode (including Vari-Program), metering system, focus area/AF mode, film advance mode, flash sync mode, multiple exposure, exposure compensation function, flash output level compensation, and Auto Exposure/Flash Exposure Bracketing settings on the camera. Change the various settings as desired.

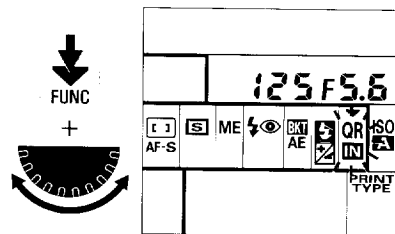

- 2 Hold **FUNC** button and rotate Main-Command Dial until function set indicator (▼) appears in the QR function area and **QR** and **IN** start blinking.



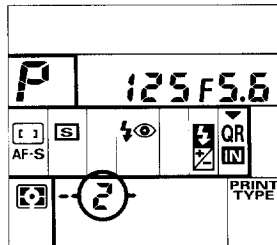
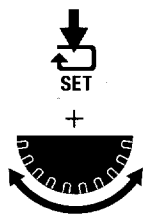

3 Hold **SET** button and rotate Main-Command Dial until desired custom setting number (between 1 and 3) appears in the frame counter area. Remove finger from **SET** button to complete setting.

- To cancel memory setting, hold **SET** button and rotate Main-Command Dial until - - - appears in the frame counter area.
- If you have already customized the QR number and selected the same number to memorize another customized setting, the previous settings will be cleared.

## TO RECALL

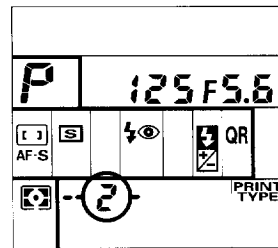

While pressing **QR-OUT** button, rotate the Main-Command Dial until your previous memory setting number appears. The LCD panel shows your customized settings. Remove finger from **QR-OUT** button. The QR number disappears and frame counter appears

- Flexible Program function is canceled when you recall any QR number.
- If you have recalled one of the QR numbers, the recalled QR number appears in place of frame counter when you press **QR-OUT** button.
- After recalling one of the QR number, you can adjust exposure mode, metering system, focus area/AF mode, film advance mode, flash sync mode, multiple exposure, exposure compensation function, flash output level compensation, and/or Auto Exposure/Flash Exposure Bracketing. However, this does not cancel the QR setting. You can recall the setting again by pressing **QR-OUT** button and rotating the Main-Command Dial until the same number appears.

## MANUAL FILM SPEED SETTING

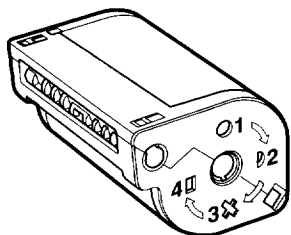

With an IX240 film cartridge having a film speed of ISO 25 to ISO 10000, the Pronea 6i automatically sets the film speed. However, you can also set the film speed manually, from ISO 6 to ISO 10000.

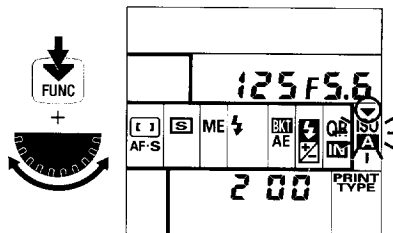

1 Hold **FUNC** button and rotate Main-Command Dial until function set indicator (▼) appears in the film speed setting area and **ISO** and **A** (if auto film speed setting is selected) start blinking. Remove finger from **FUNC** button and confirm that **ISO** and **A** stop blinking.

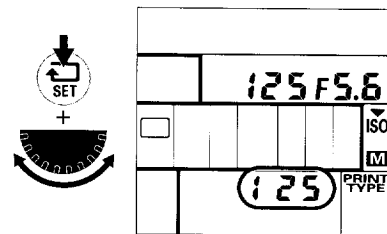

2 Hold **SET** button and rotate Main-Command Dial until desired film speed appears in the frame counter area. **A** disappears from the film speed setting area, and **M** appears. Remove finger from **SET** button to complete setting. The film speed number disappears and the frame counter appears.

---

**To cancel manual film speed setting (i.e., to set auto film speed setting):**

**1** Hold **FUNC** button and rotate Main-Command Dial until the function set indicator (▼) appears in the film speed setting area and **ISO** starts blinking.

**2** Hold **SET** button and rotate Main-Command Dial until **A** appears.



**To confirm film speed**

Hold **FUNC** button and rotate Main-Command Dial until function set indicator (▼) appears in the film speed setting area and **ISO** starts blinking. Then press **SET** button so the film speed appears in the frame counter area.

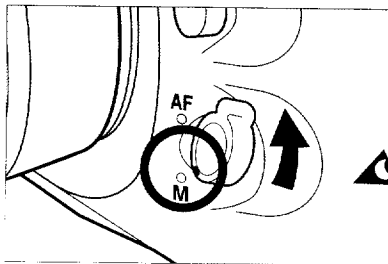
## MANUAL FOCUS



1 Set the focus mode selector to **M**.

- With the focus mode selector at **M**, only  for Wide Area or  for Spot Area appears in focus area/AF mode area of the LCD panel.

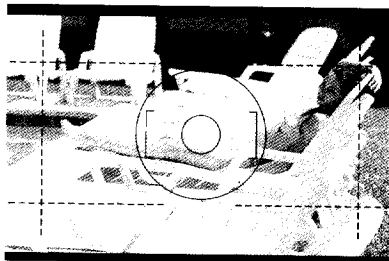

2 Look through the viewfinder and rotate lens focusing ring until the image on the clear matte field appears sharp.

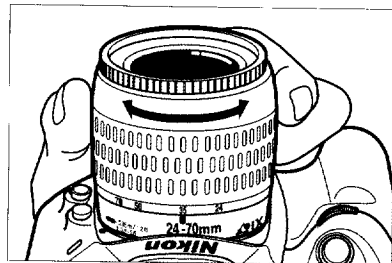

## SPECIAL FOCUSING SITUATIONS

Autofocus operation depends on general lighting, subject contrast and detail, and other technical factors. In rare situations where autofocus is not possible, ► ◀ blinks in the viewfinder to

indicate you should focus manually with the clear matte field or perform autofocus on another subject located at the same distance.

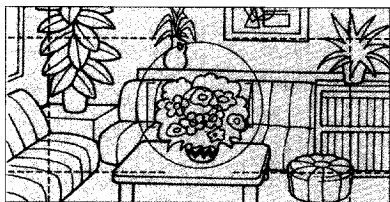

### a. Very dark subject

Focus manually with the clear matte field, or for Single Servo AF, focus on another, brighter subject located at same distance, then use focus lock (pages 69 to 70). Or use a Nikon autofocus Speedlight to perform autofocus with the Speedlight's AF illuminator.

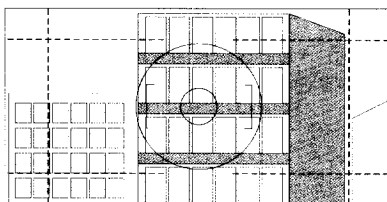

### b. Patterned subject or scene, such as building windows

Focus manually with the clear matte field, or use Single Servo AF to focus on another subject having no pattern located at the same distance, then lock focus (pages 69 to 70) and recompose.

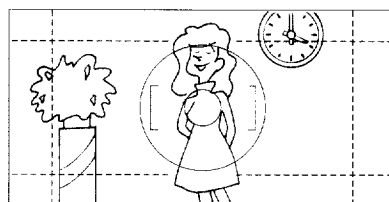

### c. Low-contrast subject

Focus manually with the clear matte field, or use Single Servo AF to focus on another subject at same distance but with more contrast, then lock focus (pages 69 to 70) and recompose.

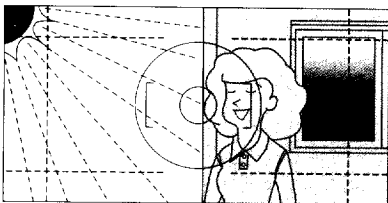

**d. Strongly backlit subject or bright subject with shiny surface such as silver or aluminum, or scene in which there is a pronounced difference in brightness.**

Focus manually with the clear matte field.

In the following situations, ignore the in-focus indicator ●:

- **Scene with subject located at different distances.** (e.g., when shooting animals inside a cage or when shooting a person over a fence.)  
Use Spot Area for autofocus (page 66) or focus manually with the clear matte field.
- **When using a linear polarizing filter\* or other special filter such as a soft-focus filter**

Focus manually with the clear matte field.

\* *Circular polarizing filter can be used in connection with autofocus operation.*

# FLASH PHOTOGRAPHY

Flash can be used not only in dim light, but also in bright conditions to fill in shadows with extra light. This technique is called “fill-flash”.

With the Pronea 6i's built-in flash or any dedicated Nikon Speedlight, you can perform an advanced fill-flash technique, Automatic Balanced Fill-Flash. This assures a correct and well-balanced exposure of both the main subject and the background.

By making fill-flash a standard part of your photography, you can take better flash pictures than ever before.

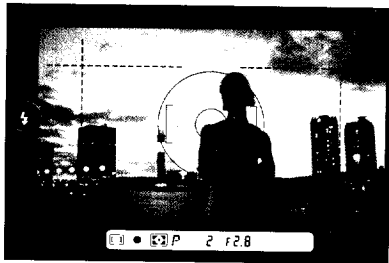

## SITUATIONS WHERE FLASH IS REQUIRED



When subject brightness is insufficient, lightly pressing the shutter release button to activate the exposure meter also turns on the flash recommended light (green ) inside the viewfinder. You can use the built-in flash or Nikon Speedlight anytime, regardless of ambient lighting. If your subject is backlit, for example, you can use the built-in flash to illuminate your subject and fill in shadows.

## TYPE OF TTL AUTO FLASH

TTL auto is recommended for most common flash shooting situations. The Pronea 6i provides three types of TTL auto flash with a built-in flash or dedicated Nikon Speedlight and a Nikkor CPU lens:

Metering system	Exposure mode	TTL auto flash
 Matrix Metering	<i>P</i> Auto-Multi Program <i>P<sub>s</sub></i> Vari-Program <i>S</i> Shutter-Priority Auto <i>R</i> Aperture-Priority Auto	Matrix Balanced Fill-Flash
	<i>M</i> Manual	Standard TTL Flash
 Center-Weighted Metering/  Spot Metering	<i>P</i> Auto-Multi Program <i>P<sub>s</sub></i> Vari-Program <i>S</i> Shutter-Priority Auto <i>R</i> Aperture-Priority Auto	Center-Weighted Fill-Flash/Spot Fill-Flash
	<i>M</i> Manual	Standard TTL Flash



---

### **Matrix Balanced Fill-Flash**

The Pronea 6i's Matrix meter reads the light levels and pattern in a scene, then signals the computer, which calculates available light exposure settings. As the shutter is released, the Pronea 6i's TTL sensor senses available light, then relays this information to the computer, which automatically compensates flash output level.

The result is a well-balanced photo that provides a correct exposure for both background and the foreground subject.

### **Center-Weighted Fill-Flash/Spot Fill-Flash**

By pointing the Center-Weighted or Spot circle at different parts of the picture, you can influence the brightness levels of available-light exposures. To maintain a desired exposure when recomposing the picture, use AE-L function. (See pages 90 to 91.)

Flash output level will be properly compensated to produce a natural fill-flash effect.

### **Standard TTL Flash**

Although this mode does not offer automatic flash output levels, your subject will be correctly exposed.

## FLASH SYNC MODE

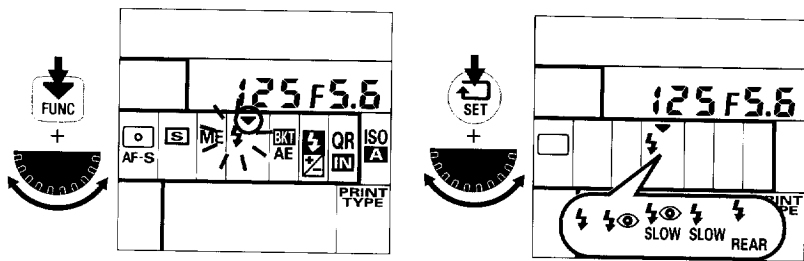

For flash photography, the Pronea 6i offers five flash sync modes.

Hold **FUNC** button and rotate the Main-Command Dial until the function set indicator (▼) appears in the flash sync mode area and the symbol in this area starts blinking.

Remove finger from **FUNC** button and confirm that the symbol stops blinking. Then hold **SET** button and rotate the Main-Command Dial until your desired symbol appears. Set ⚡ for Normal Sync\*, ⚡👁 for Red-Eye Reduction, ⚡<sup>SLOW</sup> for Red-Eye Reduction with Slow Sync, ⚡<sup>LOW</sup> for Slow Sync, or ⚡<sup>REAR</sup> for Rear-Curtain Sync.

\* When finger is removed from **FUNC** button to complete the setting, ⚡ for normal sync disappears.



### ⚡ Normal Sync

Suitable for most flash-shooting situations. In Programmed Auto or Aperture-Priority Auto exposure mode, shutter speed is controlled between 1/180 sec. and 1/60 sec.



### **Red-Eye Reduction**

When shooting people or animals in dim light using a flash, the subjects' eyes may sometimes appear red in color pictures or white in B&W pictures. Red-Eye Reduction function reduces this possibility of "red-eye".

### **Red-Eye Reduction with Slow Sync**

Red-Eye Reduction can be performed with Slow Sync.

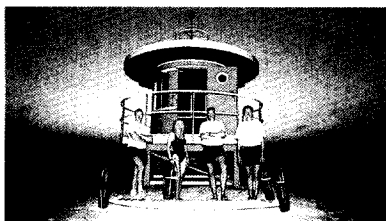

### **Slow Sync**

When flash pictures are taken at high shutter speeds in dim light, the background may turn out dark. Slow Sync improves background exposures by extending the automatically controlled shutter speed range down to 30 sec., which enables background details to emerge.

For Slow Sync, use a tripod to prevent camera shake.



### **Rear-Curtain Sync**

With Rear-Curtain Sync set, the flash fires at the end of the exposure, turning available light into a stream of light that follows the moving, flash-illuminated subject.

Rear-Curtain Sync is particularly effective at slow shutter speeds; when selecting a slow shutter speed, use a tripod to prevent camera shake.

To select your desired shutter speed, set the exposure mode to Shutter-Priority Auto or Manual.

- 
- For normal sync with Nikon Speedlight SB-24/SB-25/SB-26, set the Speedlight's flash sync mode selector to **NORMAL**.
  - Red-Eye Reduction and Red-Eye Reduction with Slow Sync can be set only with the built-in flash or Nikon Speedlight SB-26/SB-27. Setting Red-Eye Reduction with a Speedlight that does not offer Red-Eye Reduction causes  to blink in LCD panel.
  - For Slow Sync/Red-Eye Reduction with Slow Sync, set the exposure mode to Auto-Multi Program (**P**) or Aperture-Priority Auto (**A**).
  - Because Rear-Curtain Sync is particularly effective at slow shutter speeds, Slow Sync is automatically set at the same time Rear-Curtain Sync is set in Auto-Multi Program (**P**) or Aperture-Priority Auto (**A**) modes.
  - With Vari-Program, Rear-Curtain Sync cannot be set.
  - For Rear-Curtain Sync with Nikon Speedlight SB-24/SB-25/SB-26, set the Speedlight's flash sync mode selector to **REAR**.
  - For built-in flash operation, see pages 117 to 122.

## USING BUILT-IN FLASH

### Important!

- Do not touch the built-in flash while it is firing; normal operation can cause it to become very hot.
- Never fire the flash more than 20 times consecutively at intervals of 5 sec. or less; doing so could impair flash performance. After 20 consecutive firings at intervals of 5 sec. or less, let the flash rest at least 10 minutes before firing again.

Continuous flash use may cause the camera's handgrip to become hot; this is normal. Continuous firing results in a longer interval before the ready-light comes on as it takes longer for the flash to automatically recharge.

- When the built-in flash is activated, an accessory Speedlight will not fire. When using a Speedlight, keep the built-in flash in the locked down position.

### Built-in flash specifications

Usable film speed: ISO 25 to ISO 800

Guide number: Approx 20 (m) at ISO 200, at 20°C

Angle of coverage: 20mm or longer lens\*

\* Focal length used here is for IX-Nikkor lenses

## USABLE LENSES WITH BUILT-IN FLASH

### Non-Zoom AF Nikkor lenses

20mm to 300mm non-Zoom AF Nikkor lenses (AF-S 300mm f/2.8D cannot be used when shooting a subject within 3.7m/12.1 ft.). AF 300mm f/2.8 IF-ED cannot be used.

### Zoom AF Nikkor lenses

- IX-Nikkor 20-60mm f/3.5-5.6
- IX-Nikkor 24-70mm f/3.5-5.6
- IX-Nikkor 60-180mm f/4-5.6
- 20-35mm f/2.8D IF\*<sup>1</sup>
- 24-50mm f/3.3-4.5D
- 24-120mm f/3.5-5.6D IF
- 28-70mm f/3.5-4.5D
- 28-80mm f/3.5-5.6D
- 28-85mm f/3.5-4.5\*<sup>2</sup>
- 35-70mm f/2.8D
- 35-80mm f/4-5.6D
- 35-105mm f/3.5-4.5D IF
- 35-135mm f/3.5-4.5
- 70-210mm f/4-f/5.6D
- 75-300mm f/4.5-5.6
- 80-200mm f/2.8D ED
- 80-200mm f/4.5-5.6D

\*<sup>1</sup> Cannot be used when shooting a subject within 0.8m (2.6 ft.) at 35mm focal length.

\*<sup>2</sup> Cannot be used when shooting a subject within 1.3m (4.3 ft.) at 35mm focal length.

- Do not use a lens hood; it could cause slight vignetting.
- With zoom lenses, do not shoot within the macro range.

## BUILT-IN FLASH OPERATION

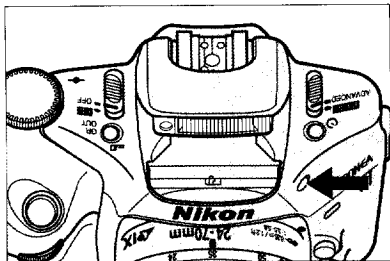

- 1 Press the flash lock-release to release and activate the built-in flash.
  - When continuous shooting (C) is set on the camera, it automatically switches to single-frame shooting (S) as soon as the built-in flash pops up, and C blinks in the LCD panel.
  - When Wide Area focus (WA) is set on the camera, it automatically switches to Spot Area focus (SP) as soon as the built-in flash pops up. In this case, SP blinks in LCD panel, and WA appears in the viewfinder.

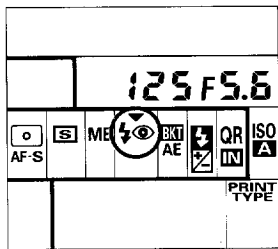

- 2 Set flash sync mode as desired (page 114). In the example illustration, Red-Eye Reduction mode is set.

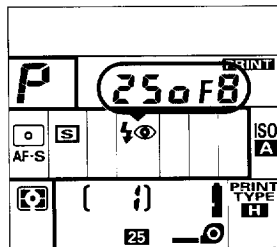

Set shutter speed and aperture. (See table on page 122.)

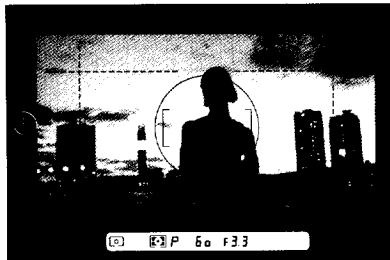
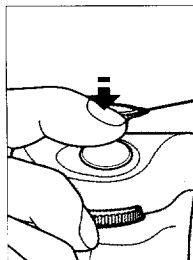

**3** Compose and lightly press shutter release button. Confirm that ● and ready-light (red ⚡) comes on in the viewfinder.

- If an electronic analog display appears in Shutter-Priority Auto, Aperture-Priority Auto or Manual exposure mode, the background may be underexposed. To obtain a correct exposure for the background:

**In Shutter-Priority Auto exposure mode**, set a slower shutter speed.

**In Aperture-Priority Auto exposure mode**, set flash sync mode to Slow Sync to extend the automatically controlled shutter speed range, or set a wider aperture.

**In Manual exposure mode**, set a slower shutter speed and/or a wider aperture.

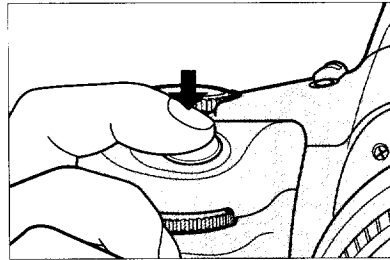

**4** Confirm subject is within the flash shooting distance range (page 121), then fully depress the shutter release button to take a shot with the flash. After shooting, check the ready-light again. If it blinks for a few seconds after shooting, the light may have been insufficient. Confirm shooting distance and, if necessary, move closer to the subject or select a wider aperture, then shoot again.

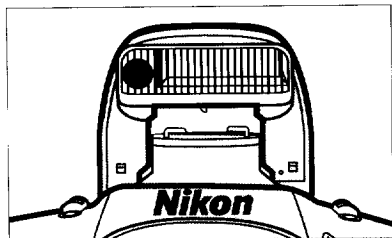

#### **With Red-Eye Reduction**

Before the shutter releases, the red-eye reduction lamp lights up for approx. one second to decrease the size of the subject's pupils, thereby reducing red-eye appearance.

#### **Firing built-in flash without film**

To save battery power, built-in flash will output small amount of light and red-eye reduction LED will also emit a small amount of light.



## FLASH SHOOTING DISTANCE RANGE

ISO film speed	25	50	100	200	400	800	Flash shooting distance range (m/ft)
Guide number (m/ft)	7/23	10/32.8	14/45.9	20/65.5	28/91.9	40/131.2	
Aperture	—	—	1.4	2	2.8	4	2.0 – 9.9/6.6 - 32.5
	—	1.4	2	2.8	4	5.6	1.4 – 7.0/4.6 - 23
	1.4	2	2.8	4	5.6	8	1.0 – 5.0/3.3 - 16.4
	2	2.8	4	5.6	8	11	0.7 – 3.5/2.3 - 11.5
	2.8	4	5.6	8	11	16	0.6 – 2.5/2.0 - 8.2
	4	5.6	8	11	16	22	0.6 – 1.8/2.0 - 5.9
	5.6	8	11	16	22	32	0.6 – 1.3/2.0 - 4.3
8	11	16	22	32	—	0.6 – 0.9/2.0 - 3.0	

---

## SHUTTER SPEED/APERTURE IN FLASH SHOOTING

The shutter speed/aperture ranges for the various exposure modes in flash shooting are as follows:

Exposure mode	Shutter speed	Aperture
Programmed Auto ( <b>P</b> , <b>P<sub>s</sub></b> )	Automatically controlled from 1/180 sec. to 1/60 sec.*1	Aperture is automatically controlled between f/2.8 and lens minimum aperture.
Shutter-Priority Auto ( <b>S</b> )	Manually set as desired from 1/180 sec. to 30 sec.*2	Aperture is automatically controlled between lens maximum and minimum aperture.
Aperture-Priority Auto ( <b>A</b> )	Automatically controlled from 1/180 sec. to 1/60 sec.*1	Manually set as desired. (Refer to FLASH SHOOTING DISTANCE RANGE on page 121.)
Manual ( <b>M</b> )	Manually set as desired from 1/180 sec. to 30 sec.*2 and <b>bulb</b>	

\*1 With Slow Sync or Rear-Curtain Sync, the controlled shutter speed range automatically extends down to 30 sec.

\*2 With the shutter speed set at 1/250 sec. or faster, the camera automatically shifts to 1/180 sec. when the built-in flash is activated (or an accessory Nikon Speedlight turned on). In this case, the blinking shutter speed indication in the LCD panel shows a manually set shutter speed while the shutter speed indication in the viewfinder shows **180**.

## FLASH EXPOSURE BRACKETING

---

For bracket exposures in flash photography, use the Flash Exposure Bracketing function. This allows you to shoot the same subject at three different flash output levels, with a varying flash output level compensation of 0.5 EV or 1 EV.

Setting a compensation degree of 0.5 EV, for example, lets you take three pictures, the first without compensation, the second with  $-0.5$  EV compensation and the third with compensation of  $+0.5$  EV.

- Flash Exposure Bracketing can be set only when the built-in flash is activated or an attached Nikon Speedlight is turned on.
- When using Flash Exposure Bracketing with the exposure compensation function or flash output level compensation, the compensated value is added. If exposure is compensated at  $+1$  EV and you set Flash Exposure Bracketing for 0.5 EV, for example, the first shot will be taken with  $+1$  EV compensation, the second shot with  $+0.5$  EV compensation and the third shot with  $+1.5$  EV compensation. When combined with exposure compensation, exposure on background will also vary.
- Auto Exposure Bracketing and Flash Exposure Bracketing cannot be set simultaneously. Setting one cancels the other.

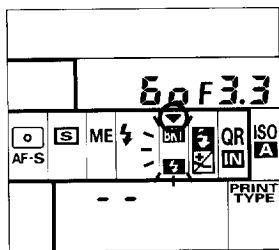
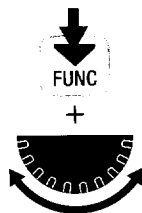

- 1 Activate the built-in flash or turn on the attached Nikon Speedlight.
- 2 Hold **FUNC** button and rotate the Main-Command Dial until the function set indicator (▼) appears in the Auto Exposure/Flash Exposure Bracketing area and **BKT** and **AE** start blinking. Remove finger from **FUNC** button so **BKT** and **AE** stop blinking.

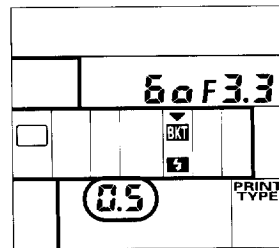
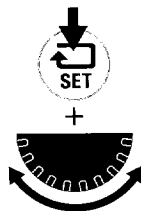

- 3 Hold **SET** button and rotate the Main-Command Dial until your desired compensation degree (**0.5** or **1.0**) appears.
  - 4 Remove finger from **SET** button to complete the setting.
- To cancel Flash Exposure Bracketing before or during bracketing operation, turn the camera off then on again, or press and hold **Ps** and **AE-L/AF-ON** buttons for more than two seconds (for Two-Button Reset). Storing the built-in flash or turning off an attached Nikon Speedlight also cancels Flash Exposure Bracketing.

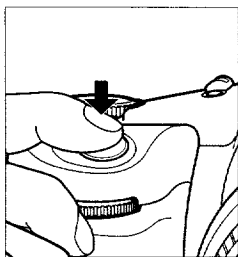

First shot is taken.

Second shot is taken.

Third shot is taken.

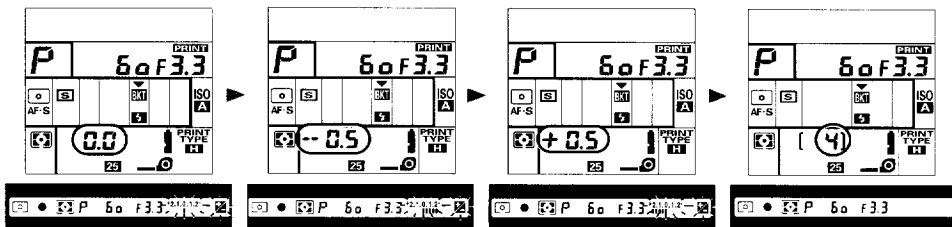

5 Compose picture, confirm focus and exposure, then fully depress the shutter release button.

**In single-frame shooting (S):** Fully depress shutter release button three times to take the three shots.

**In continuous shooting (C):** Fully depress shutter release button and hold in until three shots have been taken. (Film advance stops automatically after three shots are taken.)

- If you reach the end of the film roll during shooting, the film automatically starts rewinding. If this happens, after rewinding is complete, replace the film cartridge with a new one, then fully depress the shutter release button again to resume operation.
- After the three shots have been taken, Flash Exposure Bracketing is automatically canceled.

## FLASH OUTPUT LEVEL COMPENSATION—TO MAKE FLASH ILLUMINATED SUBJECT BRIGHTER OR DARKER

To manually adjust the flash light output level, use Flash Output Level Compensation, which allows you to adjust the light output level from -3 EV to +1 EV in 1/2 steps.

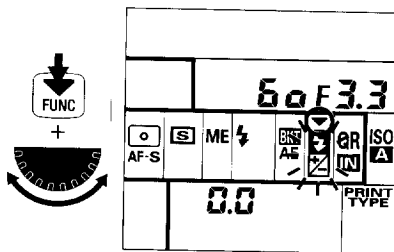

1 Hold **FUNC** button and rotate Main-Command Dial until the function set indicator (▼) appears in the Flash Output Level Compensation area and **0.0** starts blinking. Remove finger from **FUNC** button so **0.0** stops blinking.

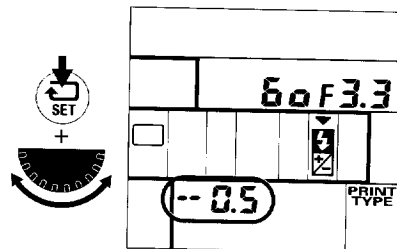

2 Hold **SET** button and rotate the Main-Command Dial until your desired compensation value appears in the frame counter area.

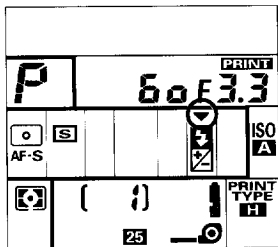

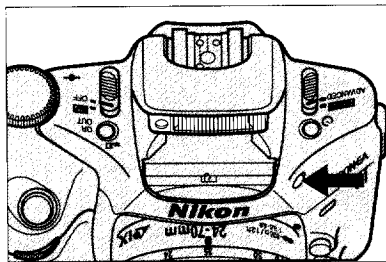

- 3 Once set, Flash Output Level Compensation remains fixed until reset. Although ▼ remains in the LCD panel to indicate exposure compensation is on, the compensation value disappears from the readout when you remove your finger from **SET** button. (▼ disappears from viewfinder when exposure meter automatically turns off.)

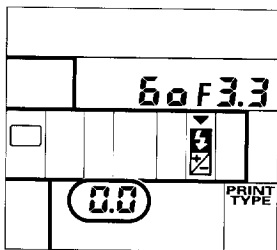
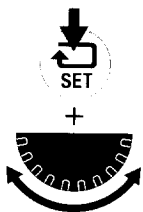

- 4 Activate the built-in flash or turn on attached Nikon Speedlight.

**To confirm compensation value in the LCD panel:**  
Hold **FUNC** button and rotate Main-Command Dial until the function set indicator (▼) appears in the Flash Output Level Compensation area and ▼ starts blinking. Then press **SET** button.



- 5 After shooting, reset the compensation amount to "0.0".  
Or, press and hold Ps and  buttons for more than two seconds (for Two-Button Reset) to cancel Flash Output Level Compensation. Switching exposure mode to Vari-Program or switching Vari-Program option also cancels Flash Output Level Compensation.



# USING ACCESSORY NIKON SPEEDLIGHT

## SPEEDLIGHT COMPATIBILITY

When using Nikon accessory Speedlight, remove accessory shoe cover.

The table below shows the available flash modes for each Nikon Speedlight.

Speedlight	Connection	Available flash mode		
		TTL auto <sup>*1</sup>	Non-TTL Auto <sup>*2</sup>	Manual <sup>*2</sup>
SB-27, SB-26, SB-25, SB-24, SB-22, SB-21B <sup>*3</sup> , SB-20, SB-16B and SB-15	Direct	Yes	Yes	Yes
SB-23	Direct	Yes	No	Yes
SB-21A and SB-16A <sup>*3</sup>	Via Flash Unit Coupler AS-6	No	Yes	Yes
SB-11, SB-14 and SB-140 <sup>*4</sup>	Via TTL Remote Cord SC-23	Yes	Yes	Yes
	Via Sensor Remote Cord SC-13 with sensor unit or Sync Cord with AS-15 coupled	No	Yes	Yes

<sup>\*1</sup> In TTL auto flash mode, Pronea 6i camera performs Automatic Balanced Fill-Flash or Standard TTL Flash. For details, see p. 113. For TTL auto flash mode, usable film speed range is ISO 25 to ISO 1000.

<sup>\*2</sup> Set the camera's exposure mode to Aperture-Priority Auto or Manual.

<sup>\*3</sup> The difference between SB-21A and SB-21B, or between SB-16A and SB-16B, is the type of controller attached. (For details, see specific Speedlight's manual).

<sup>\*4</sup> Ultraviolet and infrared photography can be performed in manual flash mode only.

### When using Programmed Auto or Shutter-Priority Auto exposure mode

Only TTL auto flash mode can be used. If a flash mode other than TTL auto is set on the Speedlight, turning on the Speedlight locks the shutter. In this case **FE** and exposure mode indicator (**P**, **P<sub>s</sub>** or **S**) blink in LCD panel, warning that the flash mode should be set to TTL auto.

## WHAT YOU CAN DO WITH NIKON SPEEDLIGHTS

The main features and functions are listed below

Speedlight	Slow Sync <sup>*1</sup>	Rear-Curtain Sync <sup>*2</sup>	Repeating Flash <sup>*3</sup>	Flash Output Level Compensation <sup>*4</sup>	Flash Exposure Bracketing <sup>*5</sup>	Red-Eye Reduction <sup>*6</sup>
SB-27	Yes <sup>*7</sup>	Yes <sup>*7</sup>	No	Yes	Yes <sup>*8</sup>	Yes
SB-26	Yes <sup>*7</sup>	Yes	Yes	Yes	Yes <sup>*8</sup>	Yes
SB-25	Yes <sup>*7</sup>	Yes	Yes	Yes	Yes <sup>*8</sup>	No
SB-24	Yes <sup>*7</sup>	Yes	Yes	Yes	Yes <sup>*8</sup>	No
SB-23, SB-22 and SB-20	Yes <sup>*7</sup>	Yes <sup>*7</sup>	No	No	Yes <sup>*8</sup>	No
SB-16B, SB-15, SB-11, SB-14 or SB-140	Yes <sup>*7</sup>	Yes <sup>*7</sup>	No	No	Yes <sup>*8</sup>	No
SB-21B	Yes <sup>*7</sup>	Yes <sup>*7</sup>	No	No	No	No

<sup>\*1</sup> See p. 115.

<sup>\*2</sup> See p. 115. With SB-27, SB-26, SB-25 or SB-24, set the Speedlight's sync mode selector to **REAR**. Normal Sync/Rear-Curtain Sync set on the camera is ignored.

<sup>\*3</sup> See Speedlight manual.

<sup>\*4</sup> See Speedlight manual..

<sup>\*5</sup> See p. 123.

<sup>\*6</sup> See p. 115.

<sup>\*7</sup> Set on the camera side.

<sup>\*8</sup> Set on the camera side; in TTL auto flash exposure mode only.

---

## NOTES ON FLASH PHOTOGRAPHY

- Use only Nikon Speedlights. Other units may damage the camera's electrical circuits due to incompatible voltage requirements\*, electric contact alignment or switch phase.

\* Not compatible with 250V or higher.

- Available maximum aperture for each film speed in Auto-Multi Program is:

ISO film speed						
25	50	100	200	400	800	1000
2.8	3.3	4	4.8	5.6	6.7	7.1

*If you are using a lens with a maximum aperture smaller than listed, of course, the automatically controlled aperture range is from the lens maximum aperture to its minimum aperture (i.e., its entire range.)*

- For multiple flash photography using the Pronea 6i, if the electric current in the synchro circuit exceeds a certain level, you may not be able to take a second shot. Take care that the combined total of the coefficient (numbers shown in parentheses below) for all Speedlights used at any one time does not exceed 20 at 20°C/68°F or 13 at 40°C/104°F.

SB-27 (1) SB-26 (1) SB-25 (1) SB-24 (1)

SB-23 (4) SB-22 (6) SB-21 (4) SB-20 (9)

SB-19 (2) SB-18 (16) SB-17 (4) SB-16 (4)

SB-15 (4) SB-14 (1) SB-12 (1) SB-11 (1)

If you are unable to take a second shot, disconnect the master Speedlight from the camera, or turn each of the Speedlights off and on once. This resets the circuits so you can resume shooting.

This also applies when using any non-Nikon studio speedlight system.

- With the SB-26, when the wireless Slave Flash Selector is set to "D", shutter speed is automatically set to 1/125 sec.

# MISCELLANEOUS

The Pronea 6i is a high-performance precision instrument, designed to give you superior pictures. To ensure optimum performance, be sure to take good care of your camera. Taking adequate time to review this section will greatly enhance your picture-taking pleasure.

We've also included information on optional accessories, a program chart and a detailed section featuring technical specifications, viewfinder/LCD panel indications and a glossary.

## FOR NON-CPU LENSES

---

- Set focus mode selector to **M** to perform Manual Focus.
- The camera's exposure meter does not function. For exposure metering, use an external exposure meter.
- Set exposure mode to Manual. (In other exposure modes, shutter is locked.)
- Shutter speed indication appears in LCD panel and inside the viewfinder. Set shutter speed by rotating Main-Command Dial. The f-number of the aperture set will not be visible in the LCD panel or the viewfinder. (**F** - always appears .) Set the aperture by rotating the lens aperture ring.

### **The following Nikkor lenses and teleconverters cannot be attached to the Pronea 6i (camera body or lens may be damaged):**

- Non-AI lenses
- AF Teleconverter TC-16A
- Lenses which require Focusing Unit AU-1
- Fisheye 6mm f/5.6
- Fisheye OP 10mm f/5.6
- Reflex 1000mm f/11 (Factory Serial No. 142361-143000)
- ED 180mm-600mm f/8 (No. 174041-174180)
- ED 360mm-1200mm f/11 (No. 174031-174127)
- 200-600mm f/9.5 (No. 280001-301922)
- AF Nikkor 80mm f/2.8 (for F3AF)
- AF Nikkor 200mm f/3.5 IF
- AF Teleconverter TC-16

## OPTIONAL ACCESSORIES

---

### **IX-Nikkor lenses (dedicated for IX240 SLR system)**

The following lenses are compact and lightweight, and cover a wide range of picture-taking opportunities.

- IX-Nikkor 20-60mm f/3.5-5.6
- IX-Nikkor 24-70mm f/3.5-5.6
- IX-Nikkor 60-180mm f/4-5.6

The following accessory rings cannot be attached to IX-Nikkor lens:

BR-4, PK-11, PK-12 and PN-11

The following accessory rings cannot be used with IX-Nikkor lens:

Bellows Focusing Attachment PB-6,  
PK-11A ring and PK-13 ring

### **Autofocus Speedlights SB-23, SB-26 and SB-27**

The AF illuminator on these Speedlights enables autofocus operation in dim light. Furthermore, when used with these Speedlights, the Pronea 6i is able to offer automatic balanced fill-flash, brightening shadows and balancing exposures of subject and background.

### **Semi-soft camera case(s)**

Two types are available: the CF-55 for use with IX-Nikkor 60-180mm f/4-5.6 or smaller lens, and the CF-56 for AF Zoom-Nikkor 70-210mm f/4-5.6D or smaller lens.

### **Eyepiece correction lenses**

To correct both near- and farsightedness, nine lenses are available with diopter values from -5 to +3. These values are derived from the dioptery of both the finder and the correction lens.

### **Cable Release AR-3**

To avoid camera shake for close-up photography or long time exposures, use Cable Release AR-3. Enables shutter release button to be locked in the down position.

When connecting to camera, be sure to turn the camera off.

# FOCAL LENGTH CONVERSION

Because IX240 film differs in size from 135 film, images obtained using the same lens will also differ.

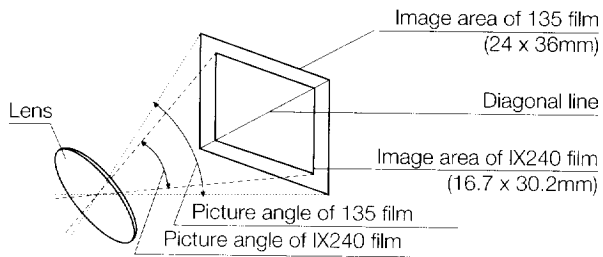

Picture angle of IX-Nikkor lenses specified is based on IX240 format; that of other lenses is based on 135 format.

The following table shows the approximate focal length of the IX240 and 135 format:

(mm)

135	24	28	35	50	60	70	85	105	135	180	200
IX240 (H type)	19	22	28	40	48	56	68	84	108	144	160

## Relationship between focal lengths of IX240 and 135 formats

Focal length of IX240 format = focal length of 135 format x 0.8

## CAMERA CARE TIPS

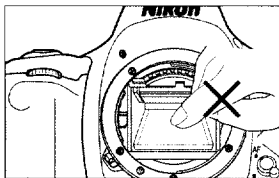

1. **Do not** touch the camera's reflex mirror or focusing screen. Remove dust with a blower brush.

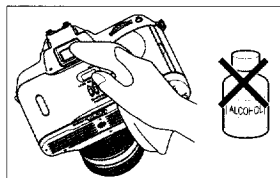

2. Clean the viewfinder eyepiece with a soft, clean cloth. **Do not** use alcohol.

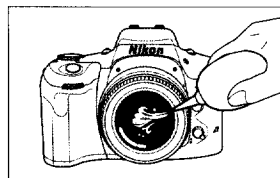

3. Clean lens surface with a blower brush. To remove dirt and smudges, use a soft, clean cotton cloth or lens tissue moistened with ethanol (alcohol) or lens cleaner. Wipe in a circular motion from center to outer edge, taking care not to leave traces and not to touch the other lens parts.

Nikon cannot be held responsible for any malfunction resulting from the use of the camera other than as specified in this manual.

### Caution!

A spray gun-type blower may damage the optical glass if used to clean the lens, especially if ED glass is used for the front lens element. To avoid damage, hold the blower upright with its nozzle more than 30cm from the lens surface, and keep the nozzle moving so the stream of air is not concentrated in one spot.



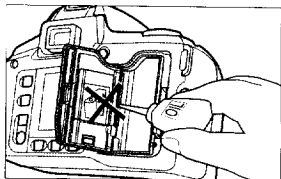

**4.** Do not lubricate the camera.

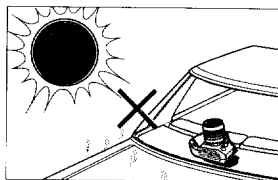

**5.** Do not leave the camera in an excessively hot place.

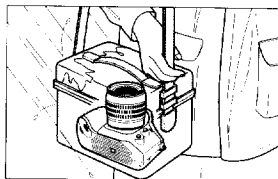

**6.** Keep the camera away from water or moisture. When using the camera near water, guard against splashes, especially salt-water spray.

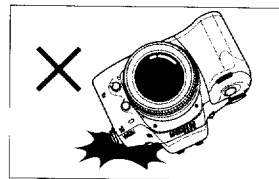

**7.** Make sure not to drop or bump the camera body/lens against a hard surface. Strong shock may cause malfunction.

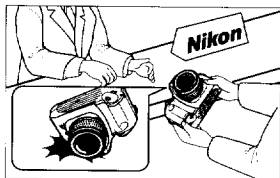

**8.** If the camera malfunctions, take it immediately to an authorized Nikon dealer or service center.

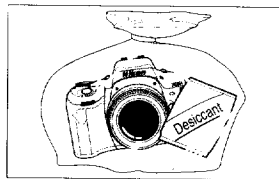

**9.** Store the camera in a cool, dry place away from naphthalene or camphor (moth repellent). In a humid environment, store the camera inside a vinyl bag with a desiccant to keep out dust, moisture and salt. Note, however, that storing leather cases in vinyl bags may cause the leather to deteriorate.

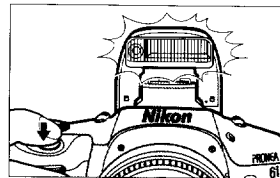

**10.** To maintain the built-in flash condenser in peak condition, fire the flash a few times every month. Thereby you can use the flash for many years.

## NOTES ON BATTERIES

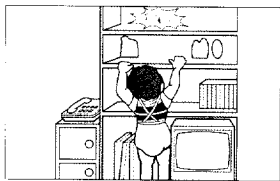

1. Keep batteries out of children's reach. If someone accidentally swallows batteries, call a doctor immediately.

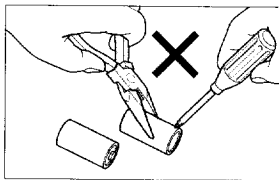

2. **Do not** disassemble, short circuit or heat batteries. **Do not** charge dry cells.

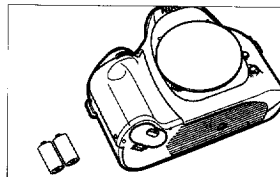

3. If you do not intend to use the camera for a long time, remove the batteries.

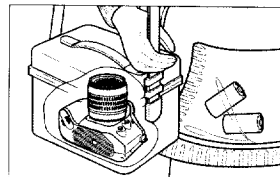

4. Battery power diminishes at extremely low temperatures—make sure the batteries you buy are new, and wrap the camera body in something warm.

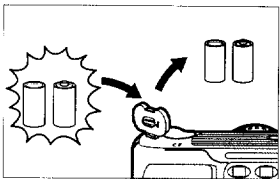

5. When replacing batteries, be sure to replace **all** batteries at the same time. Always use fresh batteries of the **same** brand.

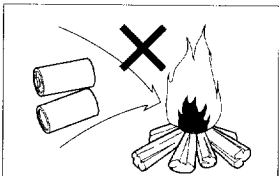

6. **Do not** throw used batteries into a fire.

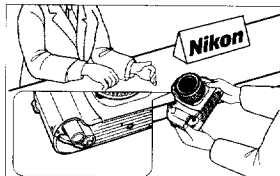

7. If the battery chamber is contaminated by battery leakage, take the camera to an authorized Nikon dealer.

## GLOSSARY

---

### **Advanced Photo System (or IX240 System)**

The new IX240 film system, compared to conventional 135mm film camera systems, is easier to operate, enables more compact camera design, offers more film-related data, records more information, and offers other benefits.

### **AE (Automatic Exposure) lock**

Holds an automatically controlled shutter speed and/or aperture. Recommended when the photographer wants to control an exposure based on a scene's particular brightness area with Centre-Weighted or Spot Metering.

### **Auto Exposure Bracketing**

Auto Exposure Bracketing operates using various shutter speeds and/or apertures in all exposure modes. (See Exposure Bracketing.)

### **Automatic Balanced Fill-Flash**

A TTL auto flash function integrating exposure meter control of ambient light exposure setting and flash exposure control. Automatically adjusts flash output to compensate for available ambient light, optimizing exposure of subject and background.

### **Auto-Multi Program**

With Auto-Multi Program, more than two combinations of shutter speed/aperture are applied. When lens focal length in use is shifted, shutter speed/aperture combination shifts while correct exposure is maintained.

### **Balanced fill-flash operation**

A technique for flash photography in which flash illumination is balanced and controlled in conjunction with the scene's ambient light.

### **Continuous Servo AF**

Focus detection continues for as long as the shutter release button is lightly pressed and the reflex mirror is in the viewing position. Useful when camera-to-subject distance is likely to change.

The Pronea 6i's Continuous Servo AF engages release-priority, so shutter can be released regardless of focus status.

### **CPU**

The Central Processing Unit is the component which controls an electronic product's functions.

AF Nikkor (including D-type AF Nikkor) and AI-P-Nikkor lenses have built-in CPUs.

---

### Depth of field

The zone of sharpest focus in front of, behind, and around the subject upon which the lens is focused. When this zone of sharpness is large, the depth of field is said to be deep; when it is small, the depth of field is said to be shallow. Depth of field varies according to numerous factors such as focal length, aperture, shooting distance, etc.

### D-type AF Nikkor lenses

These AF Nikkor lenses send to the Pronea 6i's microcomputer the distance information used for 3D Matrix Metering. Identified by the letter "D" which follows information on maximum aperture (e.g., AF Zoom-Nikkor 35-80mm f/4-5.6D). All IX-Nikkor, AF-I Nikkor, AF-S Nikkor lenses are D-type lenses.

### EV

Exposure Value: A number representing the available combinations of shutter speeds and apertures that give the same exposure effect under conditions of similar scene brightness and ISO.

At ISO 100, the combination of a one-second shutter speed and an aperture of f/1.4 is defined as EV 1.

The camera may be used only within the EV range of the exposure meter. For example, with the Pronea 6i, the exposure metering range is from EV -1 to EV 20 for Matrix metering and Centre-Weighted metering, at ISO 100 with an f/1.4 lens.

### Exposure bracketing

Shooting the same subject at a range of different exposures. The Pronea 6i camera provides Auto Exposure Bracketing and Flash Exposure Bracketing.

### Exposure compensation

Exposure compensation for available light is activated by changing shutter speed and/or lens aperture — by Auto exposure lock button, by exposure compensation, or by exposure bracketing.

In flash photography with a Nikon-dedicated TTL Speedlight, exposure compensation can also be performed by varying the amount of flash output. (See Flash Output Level Compensation.)

### Exposure control

**Programmed Auto:** Sets shutter speed and aperture for correct exposure. (The Pronea 6i camera applies two Programmed Auto Exposure Control: Auto-Multi Program and Vari-Program).

**Shutter-Priority Auto:** User selects shutter speed and camera sets matching lens aperture for correct exposure.

**Aperture-Priority Auto:** User selects aperture and camera sets matching shutter speed for correct exposure.

**Manual:** User selects both shutter speed and aperture, regardless of whether or not he follows the meter's LCD readout recommendations to achieve desired exposure.

### Fill-flash

A method of flash photography which combines flash illumination and ambient light, but does not necessarily attempt to balance these two types of illumination.

---

### **Flash Exposure Bracketing**

Enables a photographer to automatically bracket exposures at various flash output levels, in TTL auto flash shooting, without changing shutter speed and/or aperture. (See Exposure bracketing.)

### **Flash Output Level Compensation**

A control to adjust a TTL auto flash operation by increasing or decreasing flash output to lighten or darken the exposure.

### **Flash shooting distance range**

The distance range over which a flash can provide light effectively. Flash shooting distance range is controlled by the amount of flash output available. Each automatic Speedlight's flash output varies from maximum duration to minimum duration. Close-up subjects require lower (down to minimum) output, while more distant subjects require more light (up to maximum) output.

The flash shooting distance range varies according to aperture, film speed, etc.

### **Flash sync speed**

Shutter speed at which the entire film frame is to be exposed when the flash is fired in flash shooting. The Pronea 6i's flash sync speed is 1/180 sec. or slower.

### **Flexible Program**

Flexible Program function temporarily shifts an automatically selected shutter speed/aperture combination while maintaining correct exposure. That is, a desired shutter speed or aperture can be selected with the camera in Programmed Auto exposure mode.

### **Focus Tracking**

Enables the camera to assess the speed of a moving subject according to perceived focus data, then set correct focus settings by anticipating subject position—and driving the lens to that position—at the exact moment of exposure.

### **f-number**

The numbers on the lens aperture ring and on the camera's LCD which indicate the relative size of the lens aperture opening. The f-number series is a geometric progression based on changes in the lens aperture opening as it opens and closes. Going up the scale, each number is multiplied by a factor 1.4; each f-number on the scale (except for the lowest) actually represents double the amount of light transmitted through the lens using the f-number below it. The standard numbers for calibration are 1.0, 1.4, 2, 2.8, 4, 5.6, 8, 11, 16, 22, 32, etc.

---

### Front-Curtain Sync

The flash fires an instant after the front curtain of a focal plane shutter has finished traveling across the film plane. This is the way the Pronea 6i operates with the flash sync mode at Normal Sync. (See Rear-Curtain Sync.)

### Guide number

The guide number indicates flash power in relation to ISO film speed. Guide numbers are quoted in either meters or feet., and are used to calculate f/stop for correct exposure as follows:

$$f/stop = \frac{\text{guide number}}{\text{flash-to-subject distance}}$$

Using a selected aperture, the required flash-to-subject distance can be calculated by using the formula:

$$\text{flash-to-subject distance} = \frac{\text{guide number}}{f/stop}$$

Useful for determining the maximum flash-to-subject distance for flash photography.

### Hyperfocal distance

The closest point upon which a photographer can focus where depth of field is infinity. When the lens is focused for hyperfocal distance, the deepest depth of field, covering from 1/2 the hyperfocal distance to infinity, can be obtained at each f/stop. The longer the focal length, the longer the hyperfocal distance; the smaller the aperture (the larger the f/number), the shorter the hyperfocal distance.

### ISO film speed

The international standard for representing film sensitivity. The higher the number, the greater the sensitivity, and vice versa. A film speed of ISO 200 is twice as sensitive as ISO 100, and half as sensitive as ISO 400 film.

### IX240 film

IX240 film cartridges are specially designed for use with Advanced Photo System cameras. This system offers one-touch film loading and provides information about the status of film usage (indicates if film is freshly loaded, has been partially shot, has been completely shot, or has been developed). A magnetic layer coats the film surface for magnetic data recording.

### Matrix metering system

This advanced camera light metering system using multi-segment sensor and computer is available in the Pronea 6i. 3D Matrix Metering is performed when the Pronea 6i camera is used with D-type AF and IX-Nikkor lenses.

---

### Rear-Curtain Sync

Flash fires an instant before the second (rear) curtain of the focal plane shutter begins to move. When slow shutter speeds are used, this feature can create a blur effect using ambient light, i.e., the exposure traces flowing light following a moving subject, and the subject's movement is frozen at the end of the trail of light. (See Front-Curtain Sync.)

### Single Servo AF

Once the subject is in focus, focus is locked. This is useful for recomposing the picture.

For the Pronea 6i's Single Servo AF, focus-priority is given so the shutter cannot be released until the subject comes into focus.

### Slow Sync

A flash technique for using the flash at a slow shutter speed. Flash shooting in dim light or at night at a fast shutter speed often results in a flash-illuminated subject against a dark background. Using a slower shutter speed with the flash illuminates background details in the picture. Use of a slow shutter speed with Rear-Curtain Sync is particularly effective for capturing a stream of light's movement.

The Pronea 6i's Slow Sync mode extends the automatically controlled shutter speed range (in Programmed Auto and Aperture-Priority Auto) down to 30 sec.

### Standard TTL Flash

This type of TTL auto flash does not apply automatic flash output compensation. Rather, it controls flash output independently according to ambient light exposure measurement. In most cases, Standard TTL Flash illuminates a subject somewhat more strongly than Automatic Balanced Fill-Flash does, so the subject stands out more distinctly from the background.

### TTL auto flash

The camera's light sensor measures flash illumination, as reflected by the subject on the film and shuts off the flash when measurement indicates correct exposure. Because the sensor that controls the flash receives light through the lens, TTL auto flash can be used for bounce flash photography, fill-flash, multiple flash photography, etc. An additional advantage of TTL auto flash is that you can use a wide range of aperture settings, while ensuring correct exposure.

With built-in flash or dedicated Nikon TTL Speedlight, the Pronea 6i camera performs Automatic Balanced Fill-Flash and Standard TTL Flash.

### Vari-Program

Provides variable programs for specific picture-taking situations. Six programs are available with the Pronea 6i camera. (See pp. 40-45.)

### Vignetting



Progressively diminishes illumination on the film from the centre to the corners. There are two kinds of vignetting — natural vignetting caused by the lens, and vignetting caused by improper use of accessories such as a lens hood or filter.

## LCD PANEL/VIEWFINDER INDICATIONS

LCD Panel/Viewfinder	Shutter	Cause and Remedy
⏻ appears in the LCD panel.	Can be released.	Batteries are nearing exhaustion. Have a fresh set ready.
⏻ blinks in the LCD panel.	Locked.	Batteries are just about exhausted. Turn the power off and replace batteries with fresh set.
fE E blinks.	Locked.	Lens other than IX-Nikkor lens is attached but not set to the smallest aperture setting. Set lens to the smallest aperture.
Exposure mode indicator and F - - blink.	Locked.	Non-CPU lens is attached or no lens is attached. Attach Nikkor CPU lens.
E appears, and Err and ⦿ blink in the LCD panel*.	Locked.	a) Film is not correctly positioned. Reload film. b) Unusable film is loaded. Install new film.
⦿ blinks in the LCD panel.	Locked.	Film rewind is complete. Remove film cartridge.
▶ ◀ blinks in the viewfinder.	Depends on AF mode — locks in Single Servo AF; can be released in Continuous Servo AF.	Autofocus is impossible with the subject. Set focus mode selector to M and focus manually using clear matte field.
◀ stays in the viewfinder in AF mode.	Depends on AF mode — locks in Single Servo AF; can be released in Continuous Servo AF.	Subject is located closer than the closest focusing distance of the lens. Move away from subject and refocus.





\* "Err" also blinks in the viewfinder.



LCD Panel/Viewfinder	Shutter	Cause and Remedy
<b>bulb</b> blinks in the LCD panel	Locked.	a) "Bulb" is set in the Shutter-Priority Auto exposure mode. Set exposure mode to Manual or set another shutter speed. b) You set Auto Exposure Bracketing with a shutter speed set at "Bulb". To use Auto Exposure Bracketing, select another shutter speed.
<b>H i</b> appears in Auto exposure mode.**	Can be released.	Overexposure possible.
<b>L o</b> appears in Auto exposure mode.**	Can be released.	Underexposure possible.
Electronic Analog Display blinks in Manual exposure mode.	Can be released.	Subject is too dark. Select wider aperture and/or slower shutter speed, or use built-in flash or accessory Nikon Speedlight.
Shutter speed indication in the LCD panel and viewfinder blinks.	Can be released.	You are performing Auto Exposure Bracketing in Manual exposure mode. (This is proper operation.)
Green  lights up inside the viewfinder.	Can be released.	Subject is too dark. Use built-in flash or accessory Nikon Speedlight.
<b>EE</b> blinks with blinking <b>P</b> , <b>P<sub>s</sub></b> or <b>S</b> .	Locked.	Speedlight is not set at TTL auto flash. Set Speedlight flash mode to TTL, or set camera's exposure mode to Aperture-Priority or Manual.
Red  blinks inside the viewfinder after flash shooting.	Can be released.	Light might have been insufficient. Confirm shooting distance and, if necessary, move closer to subject or select wider aperture.

\* "Err" also blinks in the viewfinder.

\*\* In Shutter-Priority Auto or Aperture-Priority Auto exposure mode, viewfinder electronic analog display shows value different from correct exposure.

LCD Panel/Viewfinder	Shutter	Cause and Remedy
Shutter speed indication blinks in the LCD panel and <b>18</b> appears inside viewfinder in flash photography.	Can be released.	Shutter speed was set faster than 1/180 sec., and has automatically shifted to 1/180 sec.
 blinks in LCD panel and  appears inside the viewfinder.	Can be released.	Built-in flash or accessory Nikon Speedlight has been turned on with Wide Area focusing. Camera is automatically reset to Spot focusing.
 blinks in LCD panel.	Can be released.	Built-in flash or accessory Speedlight has been turned on in continuous shooting. Film advance mode automatically shifts to single-frame shooting.
 blinks in LCD panel.	Can be released.	Red-Eye Reduction set with a Speedlight lacking Red-Eye Reduction. Camera automatically switches flash sync mode to Normal Sync.
Electronic analog display appears in flash photography.	Can be released.	Background may be underexposed. In Programmed or Aperture-Priority Auto, set Slow Sync. In Shutter-Priority Auto or Manual, select slower shutter speed.
<b>Err</b> , and <b>PRINT</b> blink in LCD panel with or without blinking  .	Can be released.	Data is not being recording or data is improperly recorded. Film can be properly processed and printed.
<b>Err</b> blinks in LCD panel*.	Locked.	Turn camera off then on again.

\* **Err** also blinks in the viewfinder.

---

*If these alert signals still remain displayed after the corresponding measures have been practiced, please consult with the nearest Nikon service facility.*

## SPECIFICATIONS

---

<b>Type of camera:</b>	Integral-motor autofocus IX240 single-lens reflex	<b>Exposure meter duration:</b>	Remains on for 8 sec. after switch is on or after removing finger from shutter release button
<b>Picture format:</b>	16.7mm x 30.2mm (IX240 film format)	<b>Exposure modes:</b>	Programmed Auto (Auto-Multi Program and Vari-Program), Shutter-Priority Auto, Aperture-Priority Auto and Manual; <i>only Auto-Multi Program and Vari-Program are selectable in BASIC mode</i>
<b>Usable film:</b>	IX240 (Advanced Photo System) film cartridge (16.7 x 30.2mm)	<b>Programmed Auto exposure control:</b>	Camera sets both shutter speed and lens aperture automatically; Flexible Program possible
<b>Information exchange system:</b>	Magnetic Information Exchange (Mag. IX) system	<b>Shutter-Priority Auto exposure control:</b>	Aperture automatically selected to match manually set shutter speed
<b>Print aspect ratio:</b>	H, C and P types available	<b>Aperture-Priority Auto exposure control:</b>	Automatically selected shutter speed to match manually set aperture
<b>Lens mount:</b>	Nikon F mount	<b>Manual exposure control:</b>	Both aperture and shutter speed are set manually
<b>Lens:</b>	IX-Nikkor and AF Nikkor lenses	<b>Vari-Program:</b>	Six kinds built-in; Portrait, Hyperfocal, Landscape, Close-Up, Sport, and Silhouette Programs; each has its own program line; Flexible Program possible
<b>Operation mode:</b>	BASIC and ADVANCED	<b>Quick Recall function:</b>	Using the <b>QR-OUT</b> button, user-selected or original camera settings can be recalled; up to three settings can be memorized
<b>Focus mode:</b>	Single Servo AF, Continuous Servo AF, and Manual with Electronic Rangefinder	<b>Exposure compensation:</b>	With exposure compensation button; $\pm 5$ EV range, in 1/2 EV steps
<b>Focus area:</b>	Wide and Spot selectable		
<b>Focus Tracking:</b>	Automatically activated when subject moves		
<b>Autofocus detection system:</b>	Nikon CAM274 autofocus module		
<b>Autofocus detection range:</b>	Approx. EV 0 to EV 20 (at ISO 200)		
<b>Autofocus lock:</b>	Possible once stationary subject is in focus in Single Servo autofocus		
<b>Electronic rangefinder:</b>	Available in Manual focus mode with lenses having a maximum aperture of f/5.6 or faster		
<b>Exposure metering:</b>	Three built-in exposure meters — 3D Matrix, Centre-Weighted and Spot		
<b>Metering range (at ISO 200 with f/1.4 lens):</b>	EV 0 to EV 20 in 3D Matrix and Centre-Weighted, EV 4 to EV 20 in Spot		

---

**Auto exposure lock:**

By pressing AE-L button while meter is on

**Exposure bracketing:**

Three frames in 1/2 or 1 EV steps

**Multiple exposure:** Available**Shutter:**

Electromagnetically controlled vertical-travel focal-plane shutter

**Shutter speeds:**

Lithium niobate oscillator-controlled speeds from 1/4000 to 30 sec. (in 1/2 step); electromagnetically controlled Bulb setting

**Viewfinder:**

Fixed eyelevel pentaprism high-eyepoint type; approx. 100% frame coverage for printed image area in H type (at 3m); approx. 0.84x magnification with 50mm lens set at infinity

**Eyepoint:**

Approx. 20mm

**Focusing screen:** Nikon new B-type BriteView screen III; fixed**Viewfinder****information:**

LCD shows metering system, focus indication, exposure mode, shutter speed, aperture, electronic analog exposure display, exposure compensation value, flash/exposure compensation mark; flash ready-light LED and print type indicators are also shown

**LCD panel information:**

Vari-Program, shutter speed, aperture, exposure mode, Flexible Program, focus area, focus mode, film advance mode, multiple exposure, number of multiple exposure, flash sync mode, exposure/flash bracketing mark, exposure compensation, compensation value, frame counter, self-timer, title imprint, total number of exposures in cartridge, print quantity, film cartridge indicator, print type and battery power; date and time are displayed when power is off

**LCD panel illumination:**

Push illumination button to activate  
Drop-in loading system; film automatically advances to the first blank frame after inserting cartridge

**Film loading:****Film advance:**

In single-frame shooting mode, film automatically advances one frame when shutter is released; in continuous shooting mode, shots are taken as long as shutter release button is depressed; approx. 3.5 fps (3.3 fps with Focus Tracking)

**Frame counter:**

Additive type; counts back while film is being rewind

**Film rewind:**

Automatic rewind at the end of film roll; mid-roll rewind possible by pressing two film rewind buttons

**Self-timer:**

Electronically controlled; 10 sec. duration; cancelable

**Accessory shoe:** Standard ISO-type hot-shoe contact; ready-

light contact, TTL flash contact, monitor contact; mount receptacle for SB-27/

**Built-in flash:**

SB-26's Posi-Mount System provided  
Guide number: 20 (ISO 200, m); flash coverage: 20mm or longer lens; Matrix Balanced Fill-Flash, Red-Eye Reduction, Slow Sync and Rear-Curtain Sync are possible

**Flash synchronization:**

Up to 1/180 sec.

**Flash recommended light:**

Lights up when flash is recommended

**Flash ready-light:**

Lights up when flash is ready; blinks to indicate flash output level was full in previous shot

**Flash output level compensation:**

From -3 to +1 EV, in 1/2 EV steps

**Data recording function:**

Data displayed in the LCD panel with seven choices: Year/Month/Day, Year/Month/Day/Hour/Minute, Month/Day/Year, Month/Day/Year/Hour/Minute, Day/Month/Year, Day/Month/Year/Hour/Minute or No recording; 24-hour cycle with no AM/PM; built-in clock with timing accuracy within  $\pm 90$  sec. a month; power source for backup: one 3V lithium battery (CR2025-type)

**Number of film rolls per set of fresh batteries**

For autofocus operation using IX-Nikkor 24-70mm f/3.5-5.6 lens covering the full range from infinity ( $\infty$ ) to the closest distance and back to infinity ( $\infty$ ) before each shot, in Continuous Servo AF mode with film advance mode at continuous and a shutter speed of 1/180 sec. or faster.

	At 20°C/68°F (with 50% flash)	At -10°C/14°F (with 50% flash)
40-exp. film	100 (16)	50 (14)
25-exp. film	150 (25)	70 (20)

---

**Power source:** Two CR123A-type lithium batteries

**Battery power confirmation:** ■ for sufficient power; □ indicates batteries are nearing exhaustion; blinking ■ indicates batteries are just about exhausted; no indication/mark appears when batteries are completely exhausted or improperly installed

**Dimensions (W x H x D):** Approx. 135 x 98 x 73mm or 5.3 x 3.9 x 2.9 inches

**Weight (without batteries):** Approx. 560g or 19.8 oz.

*All specifications apply with fresh batteries used at normal temperature (20°C/68°F).  
Specifications and design are subject to change without notice.*

No reproduction in any form of this manual, in whole or in part (except for brief quotation in critical articles or reviews), may be made without written authorization from NIKON CORPORATION.

***Nikon***

**NIKON CORPORATION**

FUJI BLDG., 2-3, MARUNOUCHI 3-CHOME,  
CHIYODA-KU, TOKYO 100, JAPAN

**PHONE:** 81-3-3214-5311 **TELEX:** NIKON J22601

**FAX:** 81-3-3201-5856



### Caution on Data Recording

With this camera, shooting data such as date and time are magnetically recorded on the film during film rewind. However, under low temperatures, data may not be recorded properly due to the characteristics of the IX240 film. Therefore, for best results, rewind film above 0°C or 32°F.

### Hinweis zur Datenaufzeichnung

Die Aufnahmedaten (Datum, Uhrzeit usw.) werden bei dieser Kamera während der Filmrückspulung magnetisch aufgezeichnet. Bei niedrigen Temperaturen kann dies jedoch auf Grund der Besonderheiten des IX240-Films Schwierigkeiten bereiten. Wir empfehlen deshalb, die Rückspulung grundsätzlich bei einer Temperatur über 0°C vorzunehmen.

### Précaution pour l'enregistrement de données

Avec cet appareil, les données de prise de vue telles que la date et l'heure, sont enregistrées magnétiquement sur le film pendant le rebobinage de la pellicule. Mais à basses températures, les données peuvent ne pas être enregistrées correctement à cause des caractéristiques du film IX240. Pour obtenir les meilleurs résultats, rebobinez à plus de 0°C.

## Imprinted user title pocket guide

### Selecting language number and title

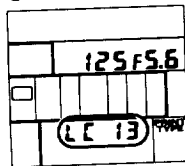
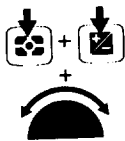

1 While pressing both and buttons, rotate Sub-Command Dial until desired language number appears with "13". For American English, select "13 13".

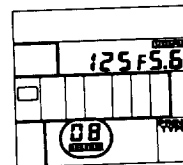

2 While pressing button, rotate Sub-Command Dial until your desired title number appears.

### To cancel title

While pressing button, rotate Sub-Command Dial until -- takes the place of the title number. Remove finger from button and confirm that disappears.

Title number	Title	Title number	Title	Title number	Title
--	No title	21	First day of School	62	—
00	Christmas	22	Tour	63	—
01	Birthday	23	New Year's	64	—
02	Vacation	24	Easter	65	—
03	Honeymoon	25	Happy New Year	66	—
04	Wedding	26	Reunion	67	—
05	Hanukkah	27	Father's Day	68	—
06	Graduation	28	Mother's Day	69	—
07	Family	29	Memories	70	—
08	Party	30	Baptism	71	—
09	Holiday	50	Halloween	72	—
10	Anniversary	51	Happy Holiday	73	—
11	Friends	52	Independence Day	74	—
12	School Event	53	Thanksgiving	75	—
13	Trip	54	Rosh Hashanah	76	—
14	I Love You	55	Yom Kippur	77	—
15	Thank You	56	Memorial Day	78	—
16	Season's Greetings	57	Labor Day	79	—
17	Happy Birthday	58	Valentine's Day	80	—
18	Congratulations	59	Canada Day	81	—
19	Merry Christmas	60	Victoria Day	82	—
20	Festival	61	Remembrance Day	83	—



**Nikon PRONEA 600i**  
**PRONEA 6i**

**Liste over mulige aftrykte titler til Pronea 600i**  
**Lista Pronea 600i :n ohjeista**  
**Liste des titres utilisateur imprimés Pronea 600i**  
**Pronea 600i Liste der aufdruckbaren**  
**Benutzertitel**  
**Pronea 600i, lista dei titoli registrati per l'uso**  
**Pronea 600i 印字タイトル一覧表**  
**Pronea 600i Liste over trykte brukertitler**  
**Liste de Títulos Registrados na Pronea 600i pelo**  
**Usuário**  
**Pronea 600i Lista över tryckta användartexter**  
**Pronea 600i Lista de títulos impresos para el**  
**usuario**  
**Pronea 600i List of Imprinted User Title**  
**Pronea 6i List of Imprinted User Title**

**Titles for British English (language No. 12)**

Title number	Title
--	No title
00	Christmas
01	Birthday
02	Vacation
03	Honeymoon
04	Wedding
05	Hanukkah
06	Graduation
07	Family
08	Party
09	Holiday
10	Anniversary of Marriage
11	Friends
12	School Event
13	Trip
14	I Love You
15	Thank You
16	Season's Greetings
17	Happy Birthday
18	Congratulations
19	Merry Christmas
20	Festival
21	First day of School
22	Tour
23	New Year's
24	Easter
25	Happy New Year
26	Reunion
27	Father's Day
28	Mother's Day
29	Memories
30	Baptism

12

**Titles for American English (language No. 13)**

Title number	Title
--	No title
00	Christmas
01	Birthday
02	Vacation
03	Honeymoon
04	Wedding
05	Hanukkah
06	Graduation
07	Family
08	Party
09	Holiday
10	Anniversary
11	Friends
12	School Event
13	Trip
14	I Love You
15	Thank You
16	Season's Greetings
17	Happy Birthday
18	Congratulations
19	Merry Christmas
20	Festival
21	First day of School
22	Tour
23	New Year's
24	Easter
25	Happy New Year
26	Reunion
27	Father's Day
28	Mother's Day
29	Memories
30	Baptism

13

Title number	Title
50	Halloween
51	Happy Holiday
52	Independence Day
53	Thanksgiving
54	Rosh Hashanah
55	Yom Kippur
56	Memorial Day
57	Labor Day
58	Valentine's Day
59	Canada Day
60	Victoria Day
61	Remembrance Day

**Nikon**

**NIKON CORPORATION**

FUJI BLDG., 2-3, MARUNOUCHI 3-CHOME,  
CHIYODA-KU, TOKYO 100 JAPAN

PHONE: 81-3-3214-5311 TELEX: NIKON J22601

FAX: 81-3-3201-5856

# Accessories for the Nikon Pronea 6i

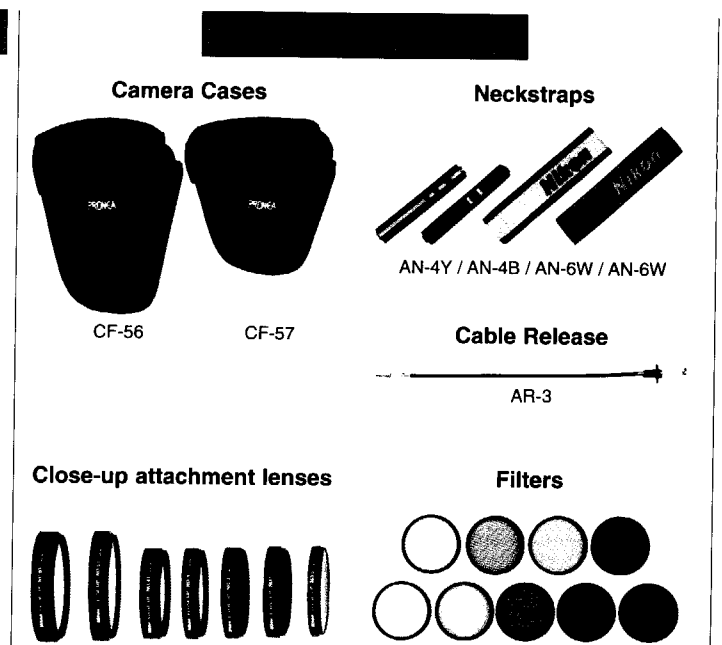
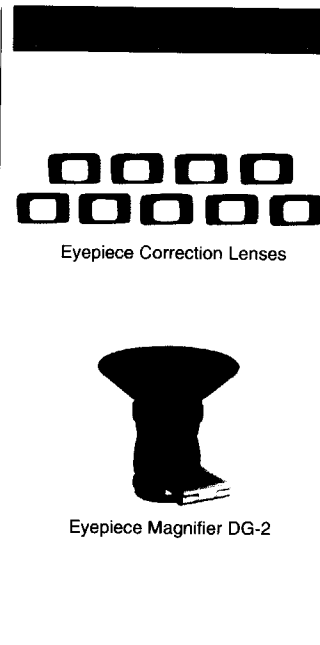
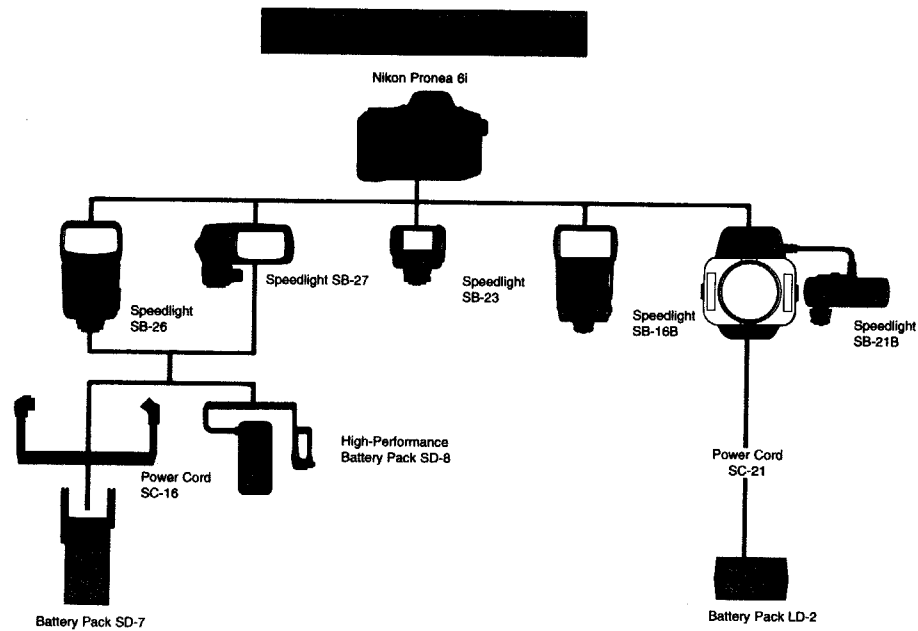

**Nikon®**  
We take the world's  
greatest pictures®  
Yours.

**Nikon**  
**PRONEA**  
IX240 Single-Lens Reflex  
**6i**

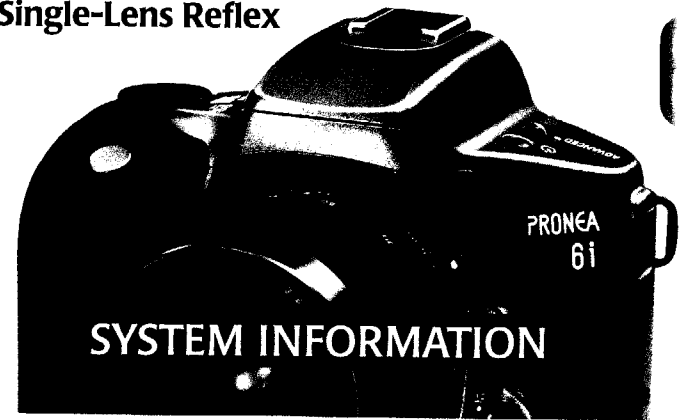

**SYSTEM INFORMATION**

# Compatible Lenses



IX 20-60mm f/3.5-5.6



IX 24-70mm f/3.5-5.6



IX 60-180mm f/4-5.6



AF-S 300mm f/2.8D ED-IF



AF-S 500mm f/4D ED-IF



AF-S 600mm f/4D ED-IF



AF-I 400mm f/2.8D ED-IF



AF-I 500mm f/4D ED-IF



AF-I Teleconverter TC-14E



AF-I Teleconverter TC-20E



AF Fisheye 16mm f/2.8D



AF 18mm f/2.8D



AF 20mm f/2.8D



AF 24mm f/2.8D



AF 28mm f/1.4D



AF 28mm f/2.8D



AF 35mm f/2D



AF 50mm f/1.4D



AF 50mm f/1.8



AF Micro 60mm f/2.8D



AF 85mm f/1.4D IF



AF 85mm f/1.8D



AF DC 105mm f/2D



AF Micro 105mm f/2.8D



AF DC 135mm f/2D



AF 180mm f/2.8D ED-IF



AF Micro 200mm f/4D ED-IF



AF 300mm f/2.8 ED-IF



AF 300mm f/4 ED-IF



AF 20-35mm f/2.8D IF



AF 24-50mm f/3.3-4.5D



AF 24-120mm f/3.5-5.6D



AF 28-70mm f/3.5-4.5D



AF 28-80mm f/3.5-5.6D



AF 28-85mm f/3.5-4.5



AF 35-70mm f/2.8D



AF 35-80mm f/4-5.6D



AF 35-105mm f/3.5-4.5D IF



AF 35-135mm f/3.5-4.5



AF 70-210mm f/4-5.6D



AF 75-300mm f/4.5-5.6



AF 80-200mm f/2.8D ED



AF 80-200mm f/4.5-5.6D



500mm f/4 P ED-IF

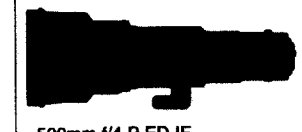

1200-1700mm f/5.6-8P ED-IF

 IX240 format

 135 format

## FOCAL LENGTH CONVERSION

Since IX240 film differs in size from 135 film, the images obtained by the same lens are also different. The following table shows the approximate focal length equivalents of the 135 and IX240 formats.

## CONVERSION TABLE OF FOCAL LENGTH

(mm)

135 format	IX240 format
16	16
20	20
28	28
35	35
50	50
70	70
85	85
105	105
135	135
200	200
300	300
400	400
500	500
600	600
800	800
1000	1000
1200	1200
1500	1500
1700	1700