

***TW*ZOOM 35◀▶80**

FCA09002

***TW*ZOOM 35◀▶80 QUARTZ DATE**

FCA09202

Zoom●Touch500S

FCA09102

Zoom●Touch500S QUARTZ DATE

FCA09302

REPAIR MANUAL

Nikon | **NIKON CORPORATION**
Tokyo, Japan

© Copyright 1991
ALL RIGHTS RESERVED
無断転載を禁ず//

目 次

TW Zoom 35<▷80

仕 様 ----- M1

展開図・部品表

〔1〕展開図

本体部・F検地ユニット部・DX接点部 (Fig. 1)-----	F 1
巻き上げ, 巻き戻しギア部 (Fig. 2)-----	F 2
ファインダー部・モーター部・スピードライトユニット部 (Fig. 3)-----	F 3
メインFPC部 (Fig. 4)-----	F 4
シャッターユニット部・鏡筒部・マスターレンズ部 (Fig. 5) 桃色頁 -----	F 5
外ヘリコイド部・鏡筒基板部・鏡筒モーター部 (Fig. 6) 桃色頁 -----	F 6
底フレキ部 (Fig. 7) -----	F 7
前カバー部 (Fig. 8) -----	F 8
後カバー部 (Fig. 9) -----	F 9
底カバー部・電池蓋部 (Fig. 10) -----	F 10

〔2〕部品表

記 号 説 明	
部 品 表 -----	P 1
部 組 品 表 -----	P 10
部 品 表 (シャッター, 鏡筒部) 桃色頁 -----	P 11
部 組 品 表 (シャッター, 鏡筒部) 桃色頁 -----	P 14

TW Zoom 35<▷80 Quartz Date

データバック ----- B1

C O N T E N T S

TW Zoom 35◀▷80

Specifications ----- M1

Exploded Drawings & Parts List

(1) Exploded drawings

BODY DIECASTING, FILM DETECTION CONTACT, DX CONTACT UNIT (Fig. 1)-----	F1
WINDING AND REWINDING GEARS (Fig. 2)-----	F2
FINDER UNIT, MOTOR UNIT, FLASH UNIT (Fig. 3)-----	F3
MAIN FPC (Fig. 4)-----	F4
SHUTTER UNIT, MASTER LENS UNIT (Fig. 5) Pink Page -----	F5
OUTER HELOCROID, LENS BARREL BASE PLATE, MOTOR UNIT (Fig. 6) Pink Page -	F6
CONNECTING FPC (Fig. 7)-----	F7
FRONT COVER (Fig. 8)-----	F8
REAR COVER, BACK DOOR (Fig. 9)-----	F9
BOTTOM COVER, BATTERY CHAMBER LID (Fig. 10) -----	F10

(2) Parts List

PARTS LIST -----	P1
ASSEMBLY LIST -----	P10
PARTS LIST (SHUTTER UNIT, MASTER LENS) Pink page -----	P11
ASSEMBLY LIST (SHUTTER UNIT, MASTER LENS) Pink page -----	P14

TW Zoom 35◀▷80 Quartz Date

Data Back ----- B1

Specifications

1. Outline

Name of product: Nikon TW Zoom 35 <▷80 (FCA09002)
 Nikon TW Zoom 35 <▷80 QUARTZ DATE (FCA09202)
 Nikon Zoom Touch 500s (FCA09102)
 Nikon Zoom Touch 500s QUARTZ DATE (FCA09302)

※ Since Zoom Touch 500s and 500s Quartz Date are available in North American market, only printed letters on the body differ from those on other models.

Major feautres: Viewfinder diopter can be switched over in two steps (-1 and +0.5). Other features are all common to those of TW Zoom.

2. Other portions modified

- (1) Body die-casting (#131) is different.
 - 1) In order to protect film from getting scratched, projections on both sides of aperture have been eliminated. Some bodies produced during the initial volume production peiod were delivered without removing projections.
 - 2) Cut off some protions close to the viewfinder and in the film cartridge chamber.
- (2) Rear cover (B123) is different.
 - 1) Diopter correction lever (#518) is added.
 - 2) Click spring (#517) is added.
 - 3) Eyepiece lens (G21) is modified.
 - 4) Rear cover is modified.
- (3) Front cover (B101) is different.
 Printed letters (name) is different.
- (4) Name plate (#663) is different.
 Printed letters (logo) is different.
- (5) Film cartridge holder (#104) is added. In approximately 15,000 units of Quartz Date produced during the initial volume production period, both temporary part #104 and sheet #104A (bottom of film, cartridge chamber) were used. While permanent part #104 only is used in the other models ans those produced after those numbers.

- (6) Some parts in the viewfinder are modified.
- 1) Type of objective lens (G11) is revised.
 - 2) Type of zoom lens (G12) is revised.
 - 3) Viewfinder mold (#501) is modified.
 - 4) Finder cover (#501) is modified.
 - 5) G15 holder (#516) is added.
 - 6) Holder spring (#515) is added.
 - 7) Screw (#803) is added.
 - 8) Two sheet of masking tape (10x8, 15x11) for preventing contamination to come inside are added.
- (7) On the bottom cover is engraved as "MADE IN JAPAN" from the initially produced products.
- (8) Data back module is modified.
Refer to specifications as shown on the data back.
- (9) A new board is attached on the flash unit. This will be replaced with permanent part in near future.
- (10) Lens barrel
As described below, two types of lens barrels have been distributed. Care should be taken for parts compatibility.
- Old type: Approx. 3,000 units. (Common to white-colored pages of TW Zoom (FCA09001) parts list.
 - New type: After above numbers. (Common to pink-colored pages of TW Zoom (FCA09001) parts list.
- Identification between old and new types:
- Adjustment lever pin: Metal (old)
Plastics (new)
 - Encoder brush stand: With eccentric pin (old)
Without eccentric pin (new)
- (11) A condenser (#1029: 0.01 μ F) is added between Q6 and Q7 on the main FPC to prevent oscillation of MD-IC.
- (12) Curtain for preventing light leakage is modified.
Though no problem was in the products produced in the initial volume production period, it has been found that the light leakage problem seldom happened. As a result, a curtain #649 for TW2 (FCA07001) has been used for TW Zoom. The shape of the curtain was modified around February 1990 and the currently used curtain #659 was developed. The curtain faces flock-side toward outside.

3. Inspection program

Inspection program for TW Zoom can be used in common.

J18206A (for 5" disk drive)

J18206B (for 3.5" disk drive)

4. About modification

Never modify from TW Zoom (including Quartz Date) to TW Zoom 35 $\triangleleft\triangleright\triangleright\triangleleft$ 80 (including Quartz Date).

Finder mechanism

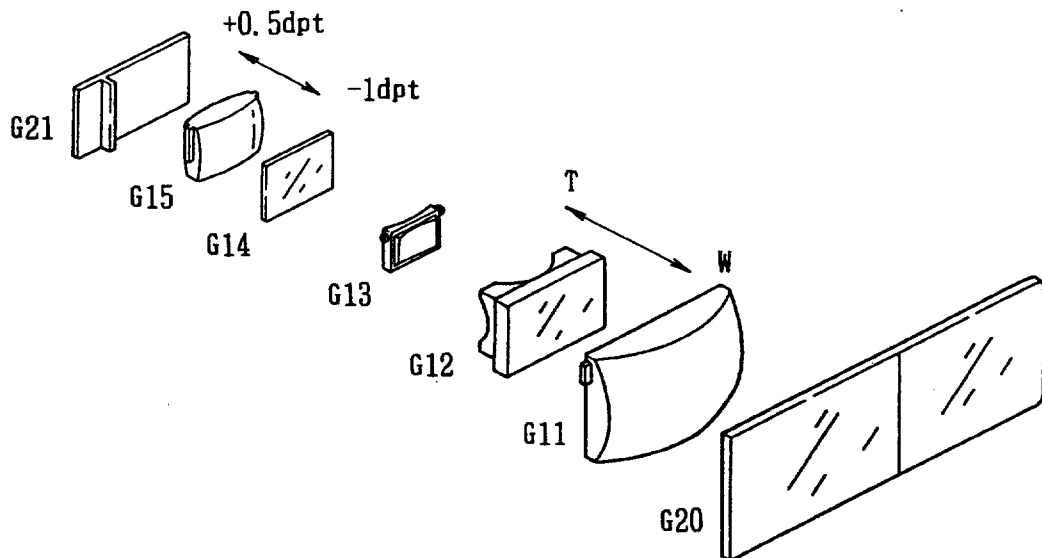

展開図の見方 How to use explosion drawings

部組品 No.
Assembly No. (component parts shown
inside the broken line)

部品要求単位
Quantity per order

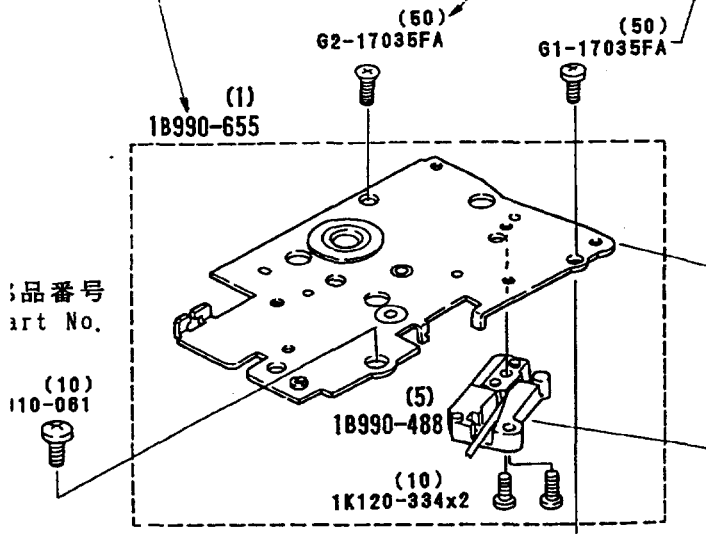

項目 Part Classification	販売区分 Term of Supply	記号 Mark
破線外で部番の入っているもの Part with Part No., shown outside the broken line	単部品で要求できるもの Available as individual part	○
破線外で部番のないもの Part without Part No., shown outside the broken line	修理部品と考えないもの Not available as repair part	×
破線内で部番のないもの Part without Part No., shown inside the broken line.	部組品でなければ要求できないもの Available only as assembly.	△
破線内で部番の入っているもの Part with Part No., shown inside the broken line	単部品でも部組品でも要求できるもの Available as assembly or individually	○△

SB基板回路图 (恒久品)
 Circuit Diagram, SB Base Plate
 (Permanent Version)

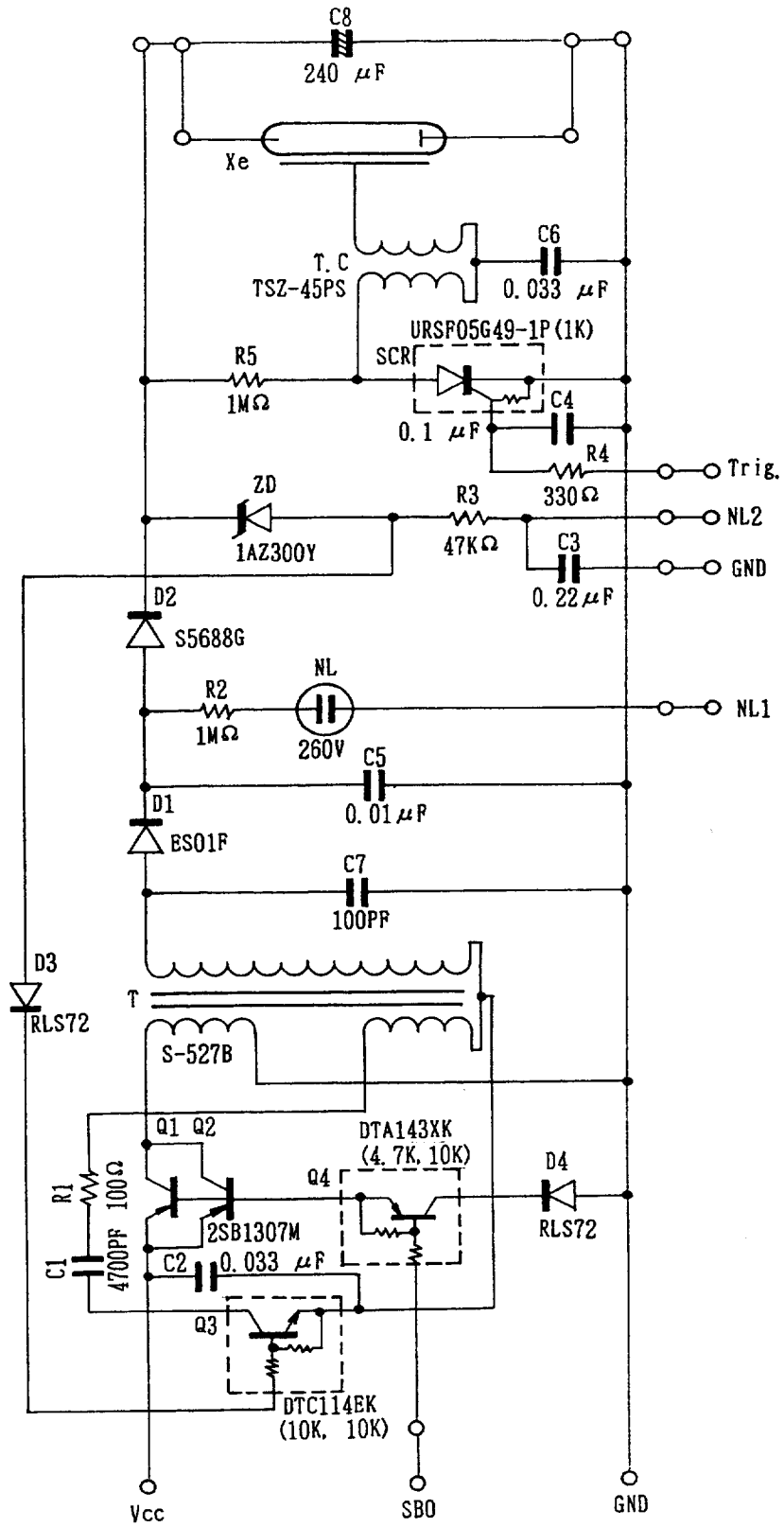

S B 基板 (恒久品)
 SB Base Plate (Permanent Version)

FGA09002-R. 3288. A

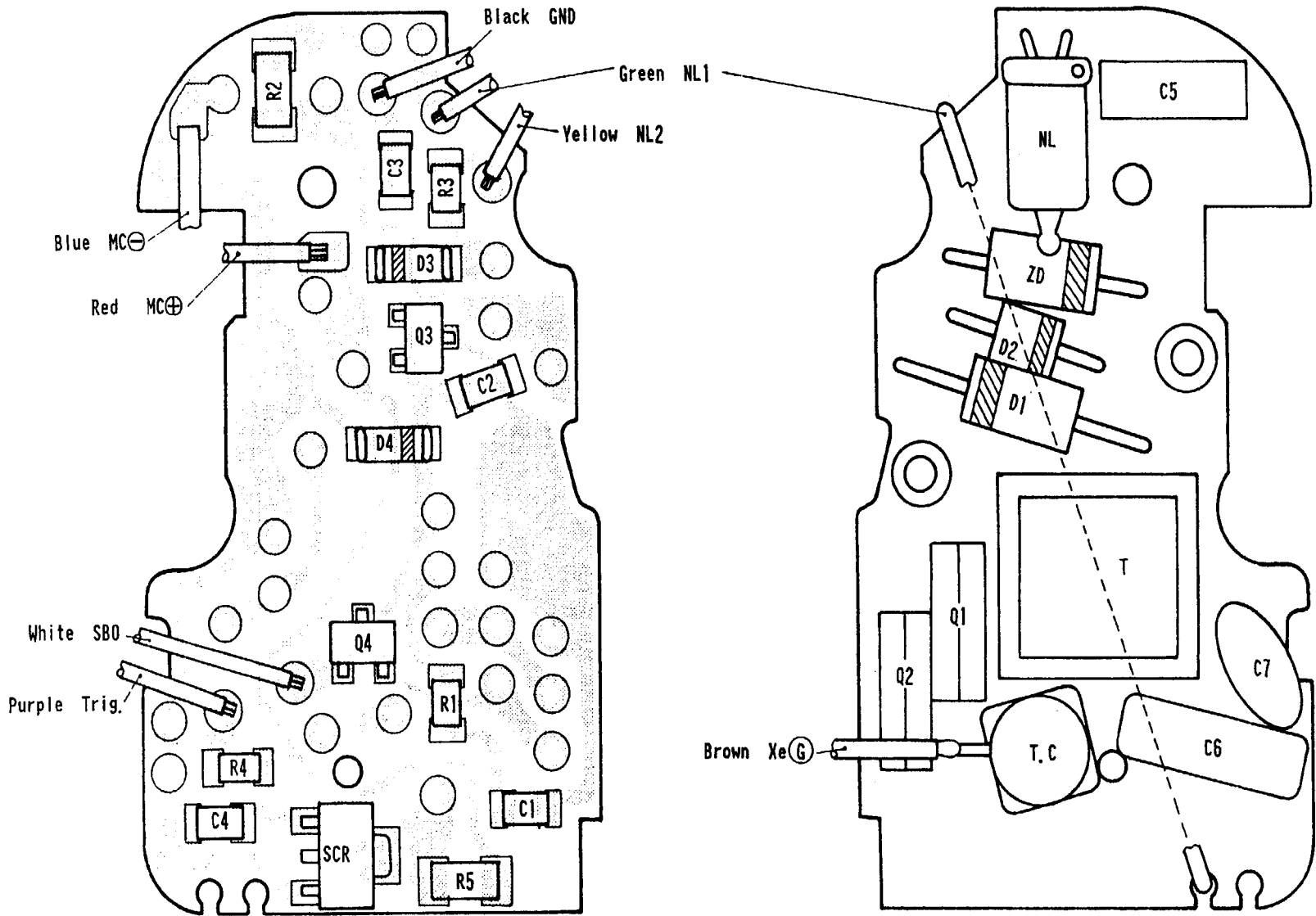

Q1	2SB1307M	D1	ES01P	C1	4700PF	C7	100PF	R1	100Ω
Q2	2SB1307M	D2	S5688G	C2	0.033 μ F	C8	240 μ F	R2	1MΩ
Q3	DTC114EK (10K, 10K)	D3	RLS72	C3	0.22 μ F			R3	47KΩ
Q4	DTA143XK (4.7K, 10K)	D4	RLS72	C4	0.1 μ F	ZD	1A2300Y	R4	330Ω
SCR	URSP05G49-1P(1K)			C5	0.01 μ F	NL	260V	R5	1MΩ
T.C.	TSZ-45PS	T	S-527B	C6	0.033 μ F				

Additional page (追加頁)

- E 2 · TW Zoom 35▷▷80-

Apr. 24, 1991

BODY DIECASTING, FILM DETECTION CONTACT, DX CONTACT UNIT

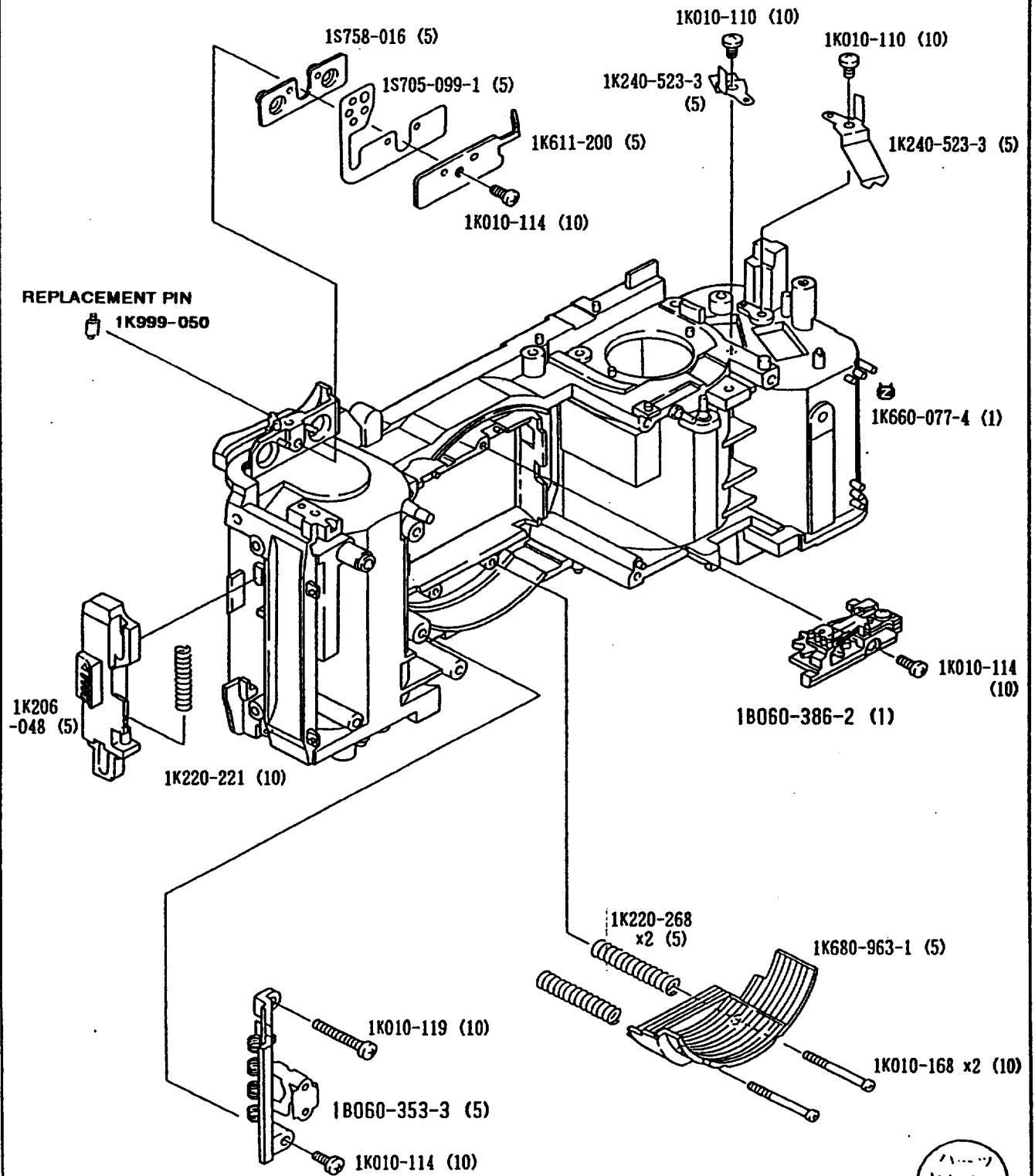

REPLACEMENT PIN
1K999-050

☞ — FCA09002 専用部品
FCA09002 PARTS FOR
EXCLUSIVE USE.



RP-INF. NO. 9522

Fig. 1

WINDING AND REWINDING GEARS

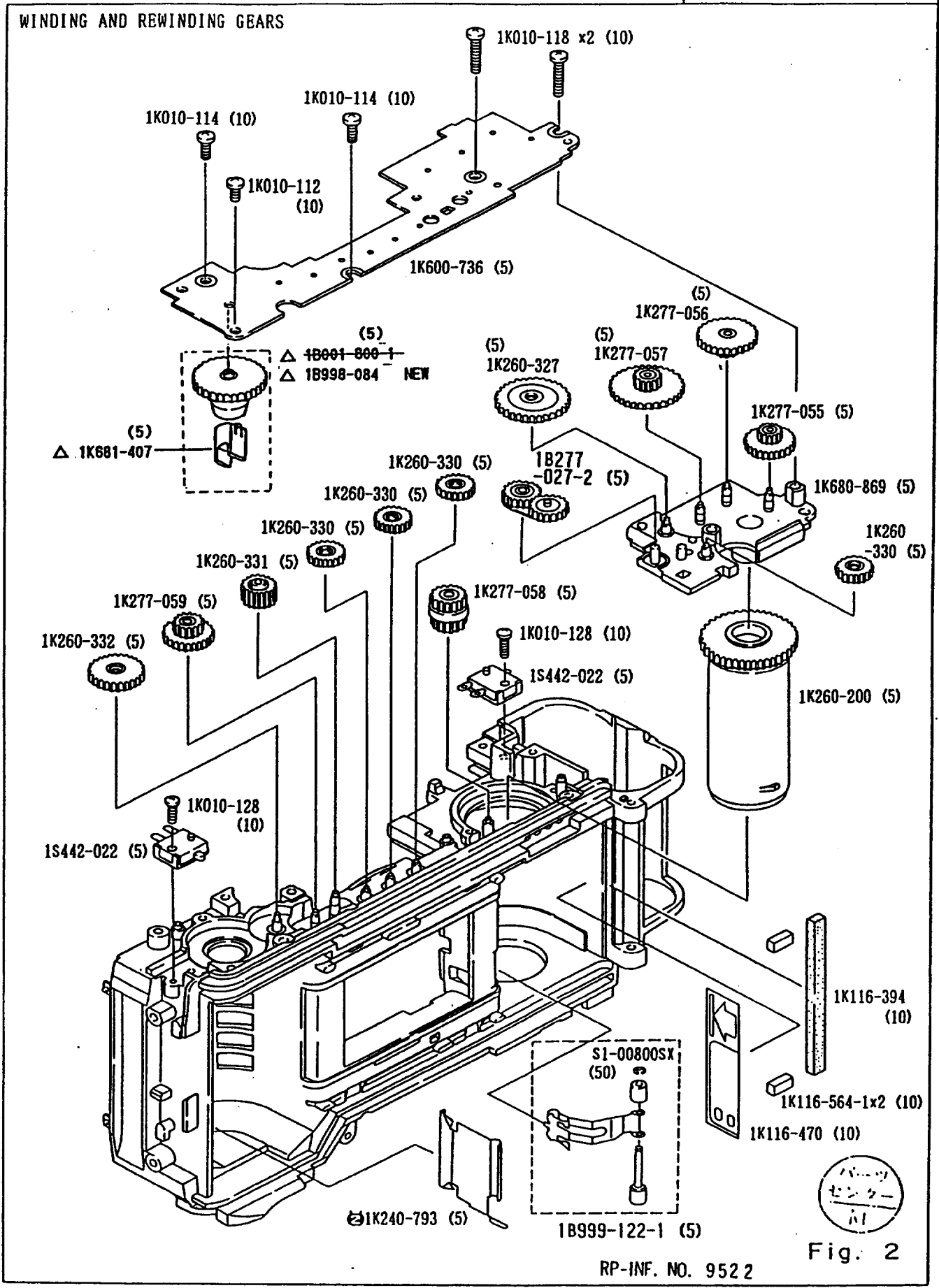

Change page(差し替え) △ x 3

- F 2 · TW Zoom 35 < > 80 -

MAR. 3.1995

FINDER UNIT, MOTOR UNIT, FLASH UNIT

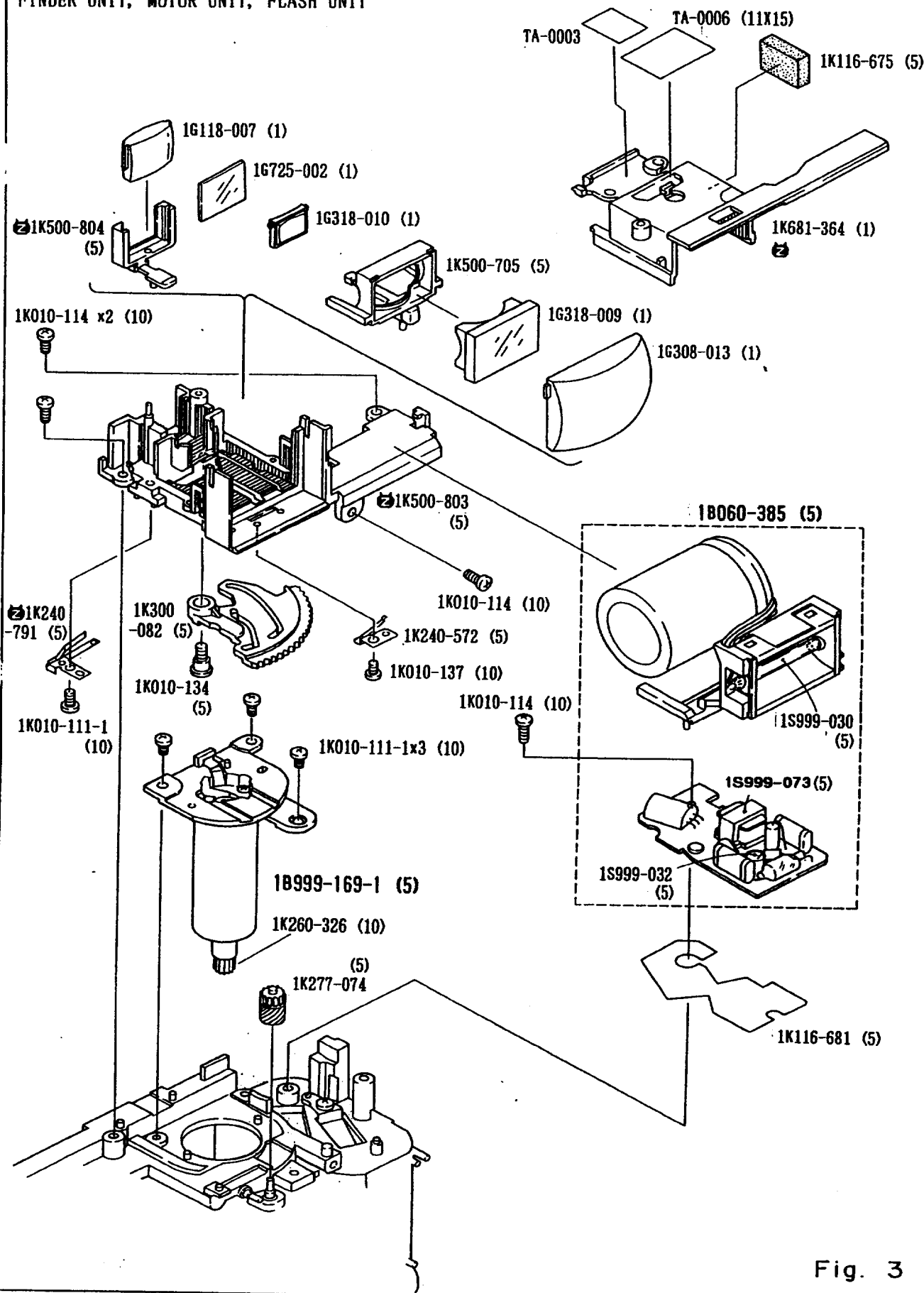

Fig. 3

MAIN FPC

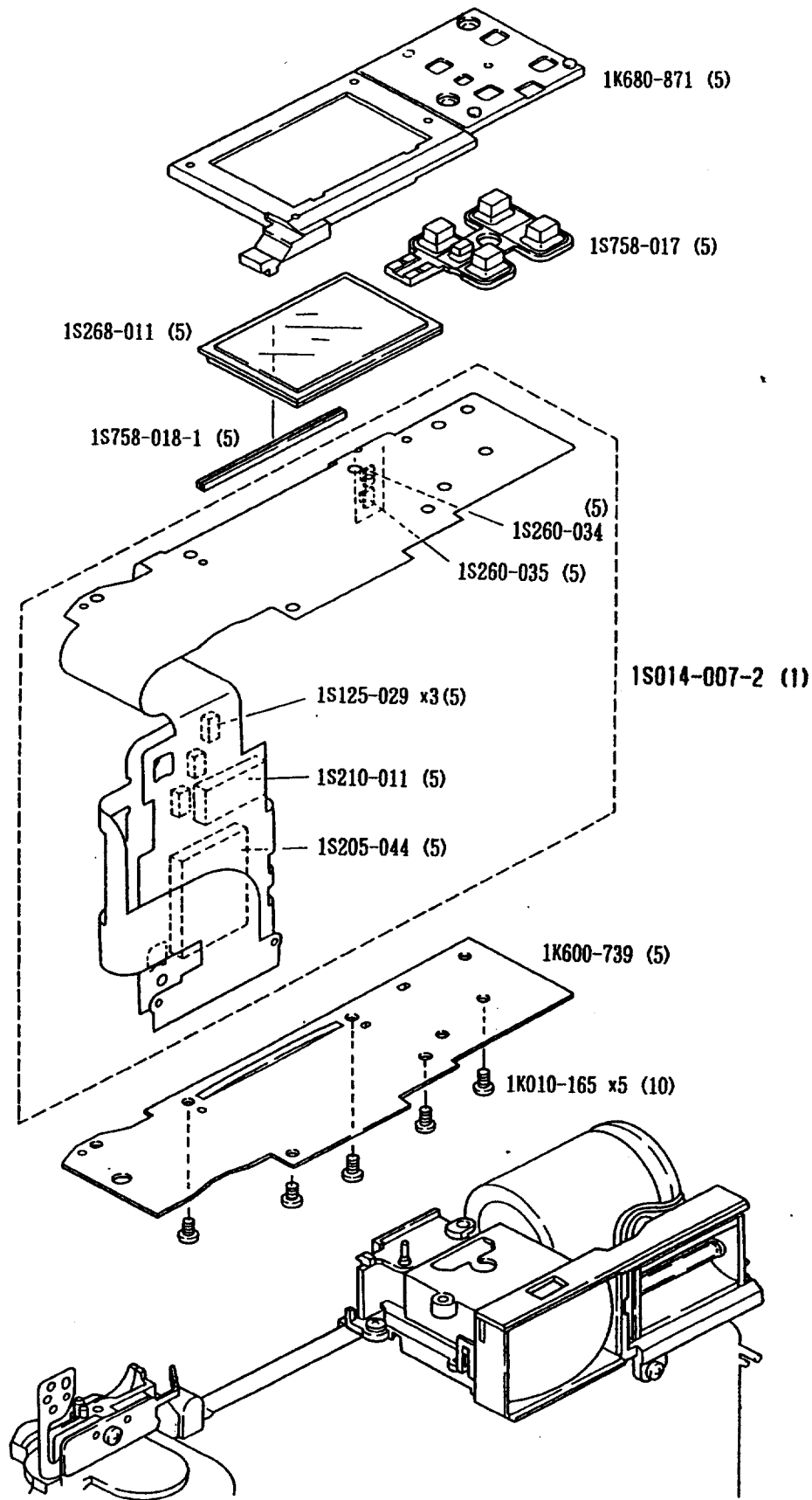
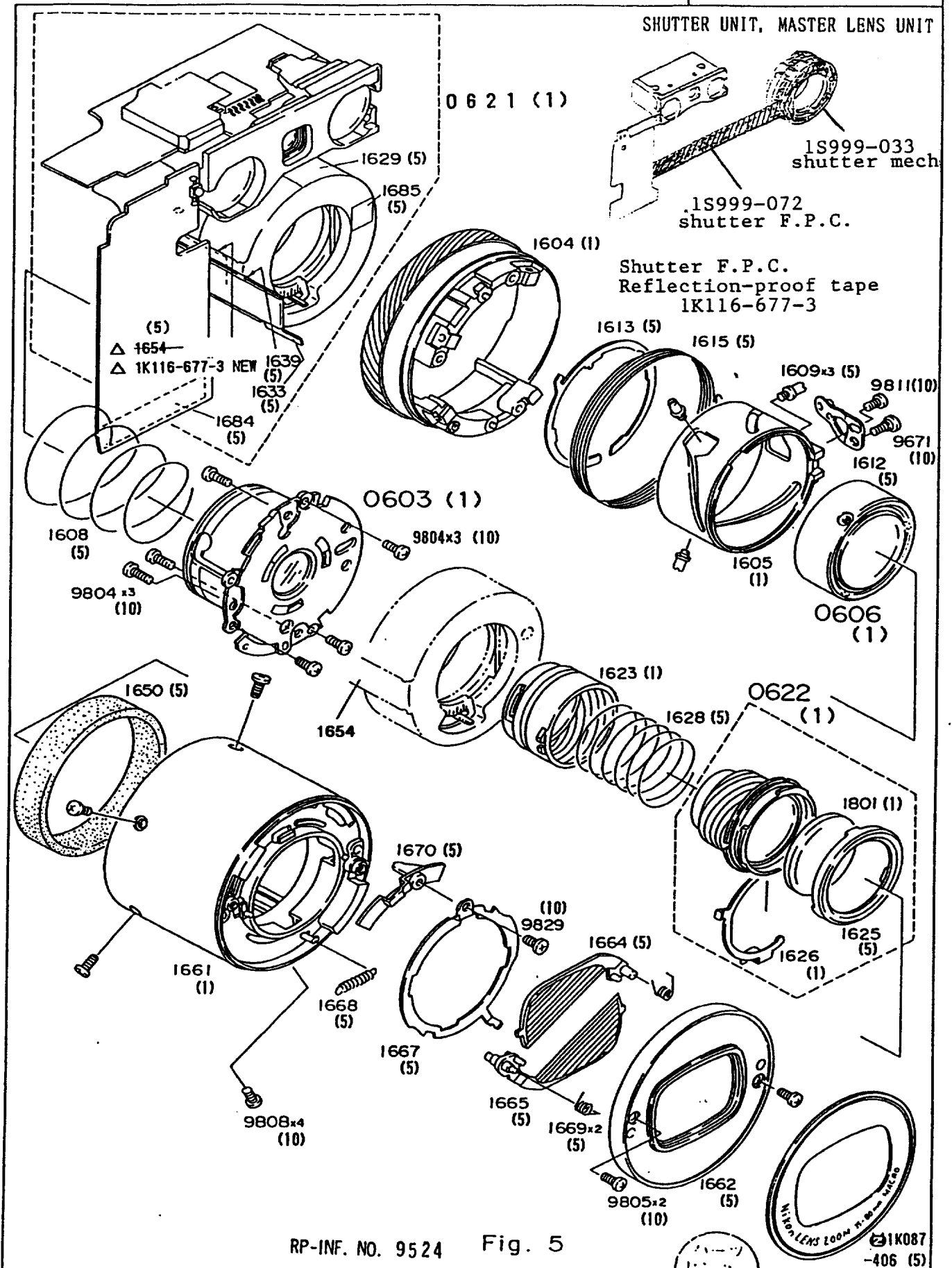

Fig. 4

SHUTTER UNIT, MASTER LENS UNIT



RP-INF. NO. 9524 Fig. 5

Change page(差し替え) △×2

- F 5 · TW Zoom 35 <▷ 80 -



1K087 -406 (5)

MAR. 10. 1995

OUTER HELOCOID, LENS BARREL BASE PLATE, MOTOR UNIT

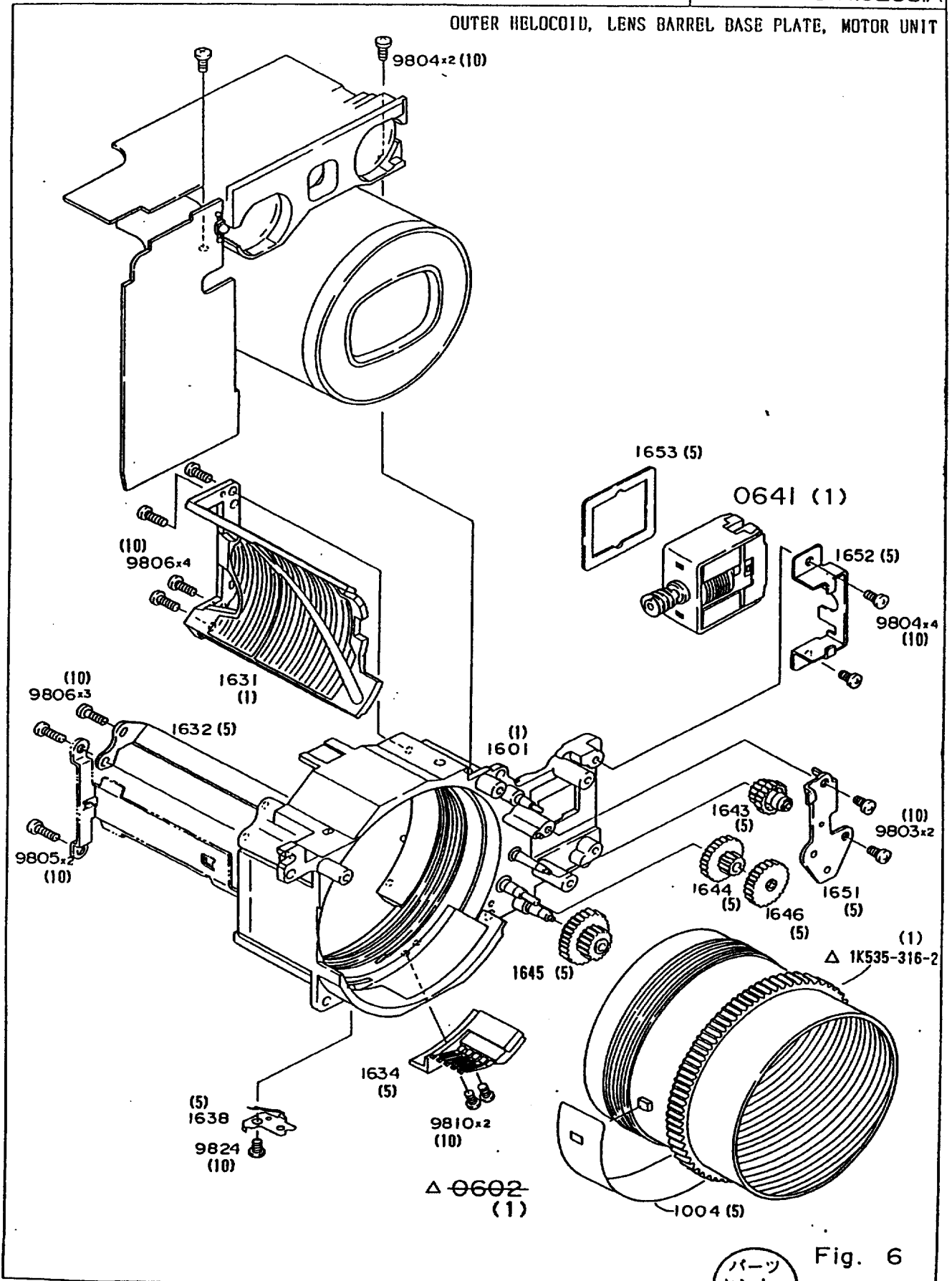

Fig. 6

Change page(差し替え) △×2

- F 6 · TW Zoom 35 <▷ 80 -



SEP. 26. 1995

CONNECTING FPC

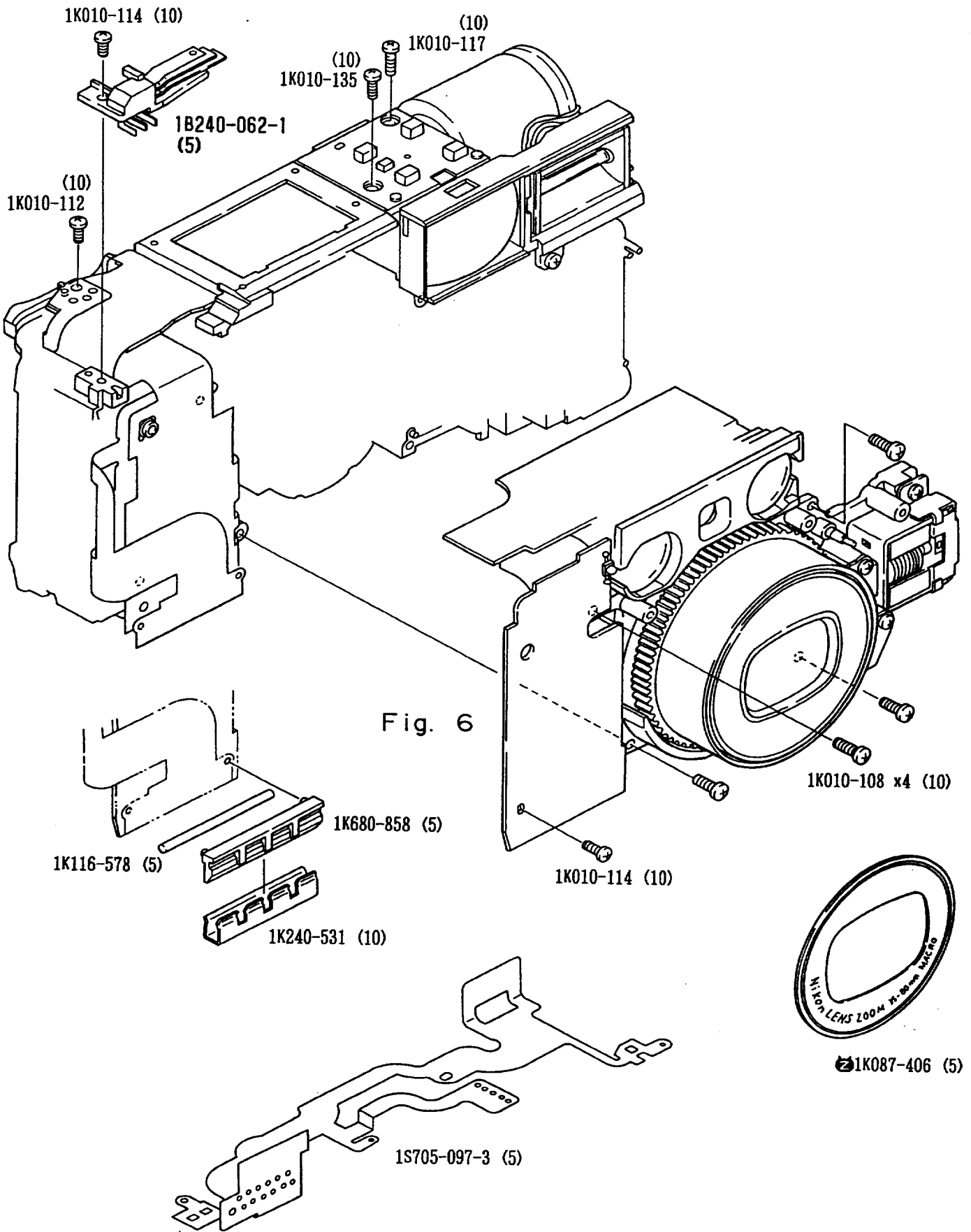

Fig. 6

Fig. 7

FRONT COVER

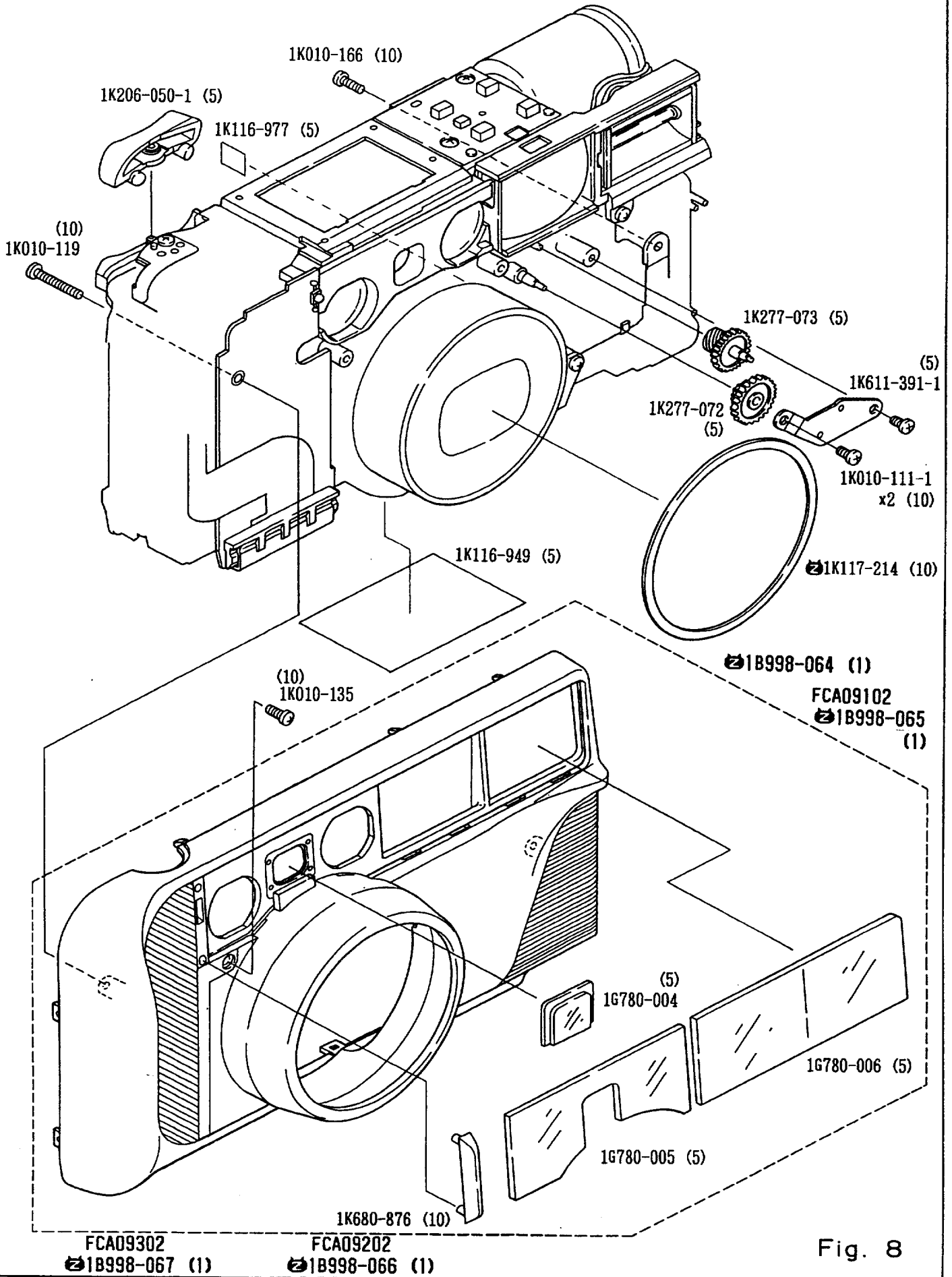

Fig. 8

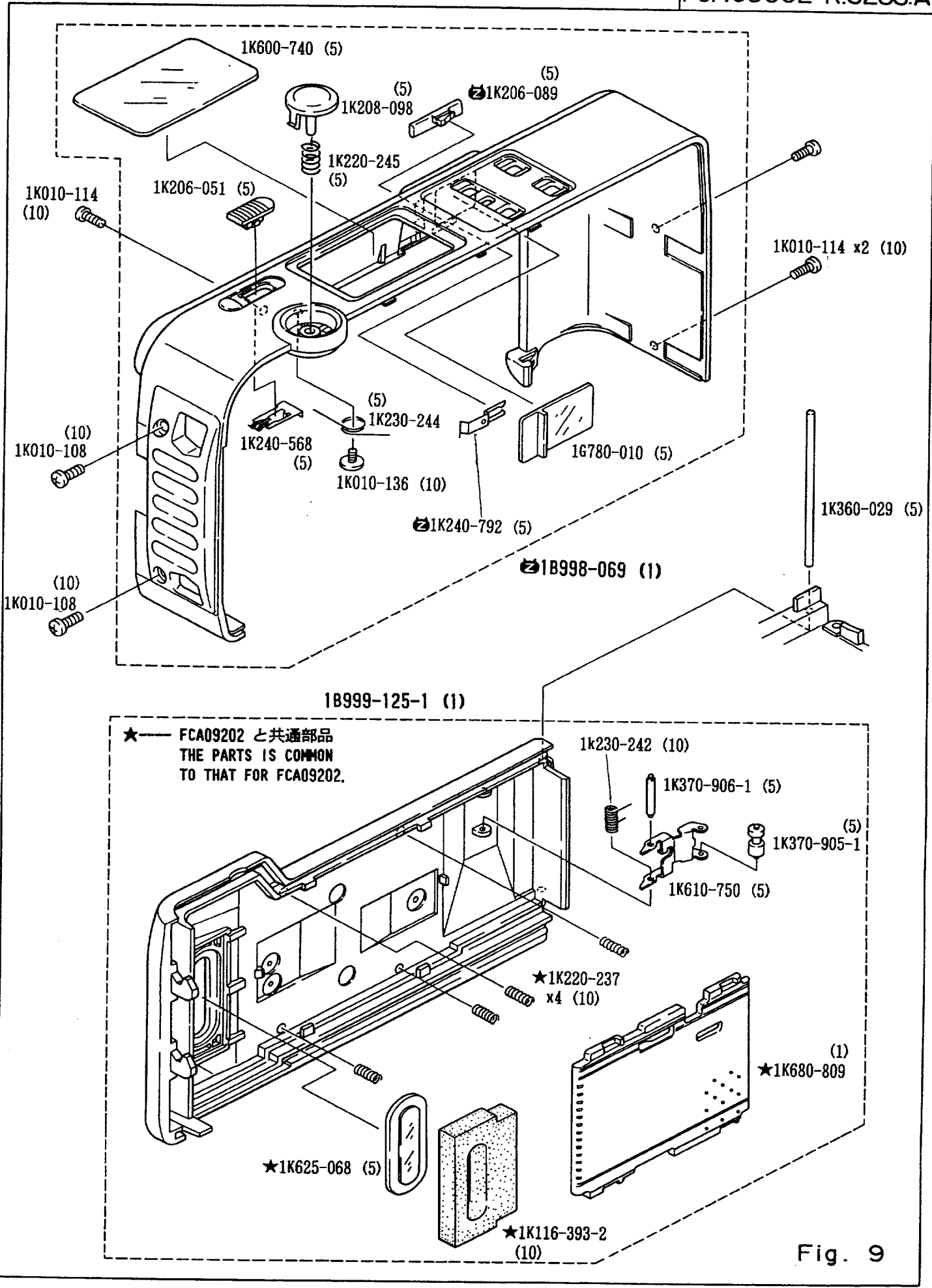

Fig. 9

BOTTOM COVER, BATTERY CHAMBER LID

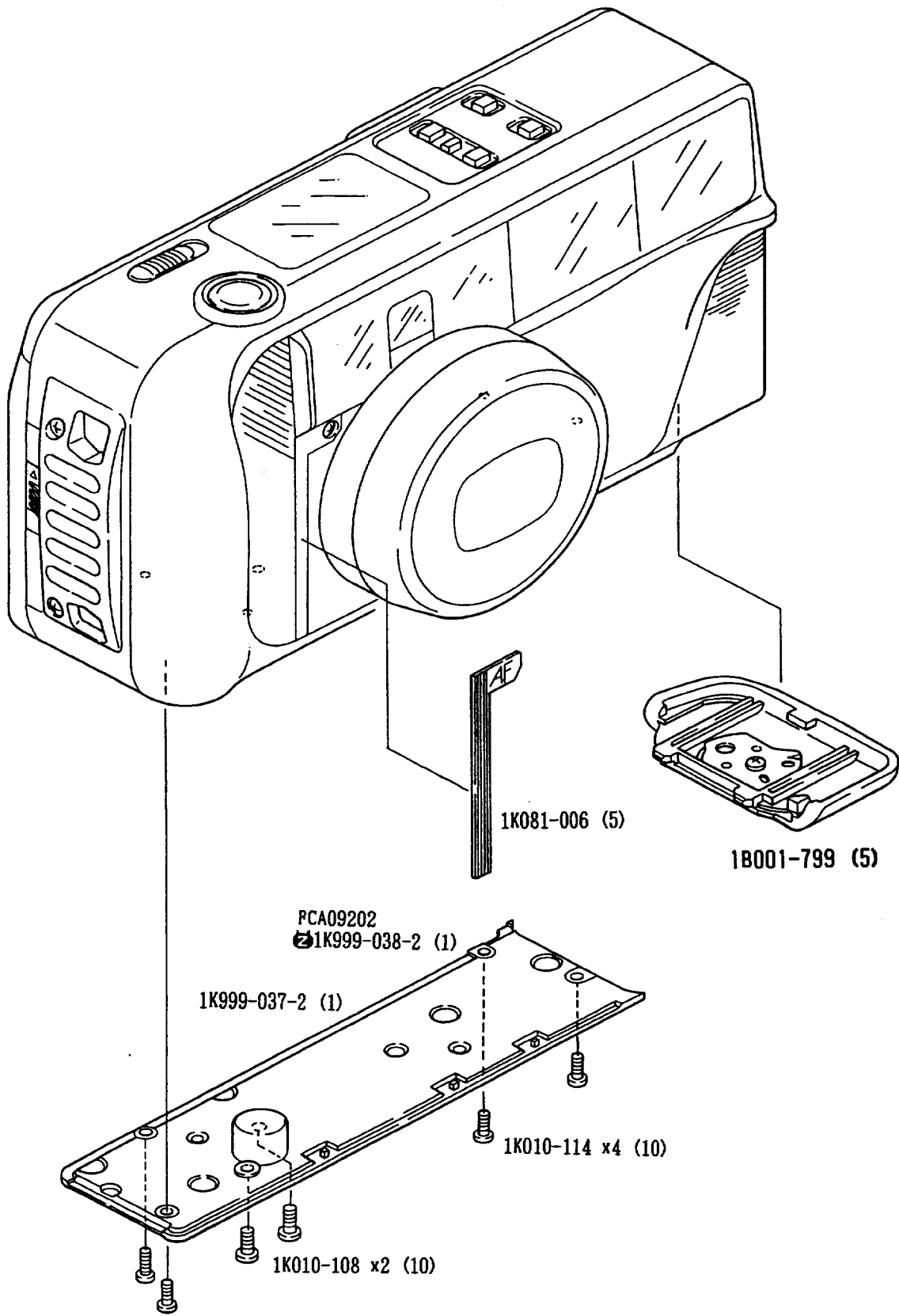

Fig. 10

(2) 販売区分欄 The term of sale colum

記号 Mark	説明 Explanation	
○	Can be Supplied individually	単独部品として販売するもの
△	Not supplied individually but only as subassembly.	部組品でなければ販売しないもの
○△	Supplied either as part or subassembly	単独部品でも部組品でも販売するもの
×	Not considered as repair part	修理部品と考えないもの
※	Should be sent to the factory if the repair needed.	単体では交換できないので、組む場合に工場での加工が必要なもの
☒	Delivered as a product from the sales department (i. e., not supplied as repair part)	商品として販売店で販売しているもの (修理部品扱いはしない)

(3) 備考欄 The remarks colum

P-601M	Part number used in common	共通部品番号
(Blue × 125mm)	Lead wire (color × length)	コードの色と長さ
53P-2013 (PM-780028)	Technical information ref. number (number in parenthesis; English edition)	製品技術資料No ()内は英文
(2.1 × 3.8 × 0.07)	Washer (internal diameter × external diameter × thickness)	ワッシャー (内径 × 外径 × 厚さ)
(Black)	Black-finished parts	黒部品
(d=0.2)	Diameter of wire	線型=0.2
(t=1)	Thickness	厚さ=1
Rev.	Revision	訂正
Add.	Addition	追加
Dis.	Discontinuation	廃止
OLD	Parts of the intial design	旧部品
◆	Limited part	R P 限定出庫部品
RP-9001	Repair part information No.	R P 情報No.
R1... D1.... W1... C1... Q1.... P1...	Abbreviation for electronic part	電気部品記号
TA-0003	Number (TA-****) are order numbers of adhesive tape. (For the order of adhesive tape, the number 1K***-*** is not use).	接着テープ要求部番 (1K***-*** では部品要求できません。)
W-0056BE	Number (W-0056BE) are order numbers of Lead wire. (For the order of Lead wire, the number 1K***-*** is not use).	リードワイヤ要求部番 (1S***-*** では部品要求できません。)

* VERSATILE PART

* 既出部品

Apart maked with this pentagonal symblo is used commonly in the arcitecture of other products. That is called "VERSATILE PART". Note that every part, bearing new part number of eleven places, will turn into a VERSATILE PART when it is used in the design of future product.

部品表 Parts List

TW Zoom 35<▷80

FCA09002-R. 3288. A

部品番号 Part No.	補助番号 Ckt. No.	名 称 Name	1台分 個数 Pcs. Per Unit	部組品番号 Assembly	参照 図番 Fig.	販売 区分 Term of Delivery	備 考 Remarks	要 求 単 位 Q'ty per order
*1K010-108	801	Screw	8		7,9 10	○	FCA09001	10
*1K010-110	811	Screw	2		1	○	FCA09001	10
*1K010-111-1 (1K010-111)	803	Screw	6		3 8	○	FCA09001	10
*1K010-112	804	Screw	2		2 7	○	FCA09001	10
*1K010-114	805	Screw	18		1,2 3,7 9,10	○	FCA09001	10
*1K010-117	809	Screw	1		7	○	FCA09001	10
*1K010-118	807	Screw	2		2	○	FCA09001	10
*1K010-119	814	Screw	2		1,8	○	FCA09001	10
*1K010-128	827	Screw	2		2	○	FCA09001	10
*1K010-134	510	ズームカム軸 Shaft, zoom cam	1		3	○	FCA09001	5
*1K010-135	806	Screw	5	1B060-386-2	7 8	○△	FCA09001	10
*1K010-136	823	Screw	1	1B998-069	9	○△	FCA09001	10
*1K010-137	824	Screw	1		3	○	FCA09001	10
*1K010-165	802	Screw	5		4	○	FCA09001	10
*1K010-166	828	Screw	1		8	○	FCA09001	10
*1K010-166	828	Screw	1		8	○	FCA09001	10

部品表 Parts List

FCA09002-R. 3288. A

部品番号 Part No.	補助番号 Ckt. No.	名称 Name	1台分 個数 Pcs. Per Unit	部組品番号 Assembly	参照 図番 Fig.	販売 区分 Term of Delivery	備考 Remarks	要求 単位 Q'ty per order
*IK010-168	152	ガイド軸 Guide shaft	2		1	○	FCA09001	10
*IK081-006	113	赤ライン Red line	1		10	○	FCA09001	5
IK087-406	663	銘板 Name plate	1		5, 7	○		5
*IK116-393-2 (IK116-393)	110	パトローネモルト Light-tight sponge, patrone window	1	1B999-125-1	9	○△	FCA09001, FCA09202 9145	10
*IK116-394	132	蝶番モルト Light-tight sponge, body	1		2	○	FCA09001	10
*IK116-470	133	フィルム先端シール Label, film load position	1		2	○	FCA09001	10
*IK116-564-1 (IK116-564)	137	モルト Light-tight sponge	2		2/	○	FCA09001	10
*IK116-578	715	圧接ゴム Press-contact rubber	1		7	○	FCA09001	5
*IK116-675	511	コンデンサ固定モルト Condenser setting sponge	1		3	○	FCA09001	5
*IK116-681	236	絶縁板 Insulating plate	1		3	○	FCA09001	5
*IK116-869	366	アセテートテープ 11×15 Acetate tape	1		3	×	TA-0006	
*IK116-949	686	テープ Tape	1	TA-0008	8	△ ×○	TA-0008 9114	
*IK116-977	161	遮光シート Light-baffle sheet	1		8	○		5
IK117-214	659	遮光リング Light-baffle ring	1		8	○		10

部品表 Parts List

FCA09002-R. 3288. A

部品番号 Part No.	補助番号 Ckt. No.	名称 Name	1台分 個数 Pcs. Per Unit	部組品番号 Assembly	参照 図番 Fig.	販売 区分 Term of Delivery	備考 Remarks	要求 単位 Qty per order
*1K206-048	111	裏蓋閉閉鍵 Lock key	1		1	○	FCA09001	5
*1K206-050-1 (1K206-050)	410	ズームレバー Zoom lever	1		8	○	FCA09001	5
*1K206-051 (1K206-051)	141	メインSW Main SW	1	1B998-069	9	○△	FCA09001	5
1K206-089	518	視度補正レバー Visibility correction lever	1	1B998-069	9	○△		5
*1K208-098	105	リリース紐 Release button	1	1B998-069	9	○△	FCA09001	5
*1K220-221	112	鍵ばね Lock key spring	1		1	○	FCA09001	10
*1K220-237	116	圧板コイルばね Pressure plate spring	4	1B999-125-1	9	○△	FCA09001, FCA09202	10
*1K220-245	128	リリース紐ばね Release button spring	1	1B998-069	9	○△	FCA09001	5
*1K220-268	153	ばね Spring	2		1	○	FCA09001	5
*1K230-242	119	フィルムローラ押えばね Spring, back door film roller arm	1	1B999-125-1	9	○△	FCA09001	10
*1K230-244	143	メインSWばね Main SW. spring	1	1B998-069	9	○△	FCA09001	5
*1K240-523-3 (1K240-523)	235	電池接片 Battery contact	2		1	○	FCA09001	5
*1K240-531	716	圧接ばね Press-contact spring	1		7	○	FCA09001	10
*1K240-568	142	メインSWブラシ Main SW. contact	1	1B998-069	9	○△	FCA09001	5

部品表 Parts List

FCA09002-R. 3288. A

部品番号 Part No.	補助番号 Ckt. No.	名称 Name	1台分 個数 Pcs. Per Unit	部組品番号 Assembly	参照 図番 Fig.	販売 区分 Term of Delivery	備考 Remarks	要求 単位 Qty per order
*1K260-326	203	モーターピニオン Motor pinion	1	18999-169-1	3	○△	FCA09001	10
*1K277-055	204	ギア 2-3 Gear 2-3	1		2	○	FCA09001	5
*1K277-056	205	ギア 4-5 Gear 4-5	1		2	○	FCA09001	5
*1K277-057	206	ギア 6-7 Gear 6-7	1		2	○	FCA09001	5
*1K277-058	211	ギア 12-13 Gear 12-13	1		2	○	FCA09001	5
*1K277-059	217	ギア 26-27 Gear 26-27	1		2	○	FCA09001	5
*1K277-072	505	ギア 1 Gear 1	1		8	○	FCA09001	5
*1K277-073	506	ギア 2 Gear 2	1		8	○	FCA09001	5
*1K277-074	507	ギア 3 Gear 3	1		3	○	FCA09001	5
*1K300-082	504	ズームカム Zoom cam	1		3	○	FCA09001	5
*1K360-029	122	裏蓋軸 Back door shaft	1		9	○	FCA09001	5
*1K370-905-1	118	フィルムローラー Back door film roller	1	18999-125-1	9	○△	FCA09001	5
*1K370-906-1 (1K370-906)	120	フィルムアーム軸 Shaft. back door film roller arm	1	18999-125-1	9	○△	FCA09001	5
*1K500-705	503	G12ホルダー G12 holder	1		3	○	FCA09001	5
1K500-803	501	ファインダーモールド Finder box	1		3	○		5
1K500-804	516	G15ホルダー G15 holder	1			○		5

Change page (差し替え)

-P 5 - TW Zoom 35 <D>80-

RP-INF. NO. 9522

MAR. 3.1995



部品表 Parts List

FCA09002-R. 3288. A

部品番号 Part No.	補助番号 Ckt. No.	名称 Name	1台分 個数 Pcs. Per Unit	部組品番号 Assembly	参照 図番 Fig.	販売 区分 Term of Delivery	備考 Remarks	要求 単位 Qty per order
*1K600-736	202	M・M地板 M・M base plate	1		2	○	FCA09001	5
*1K600-739	709	裏打板 Backing plate	1		4	○	FCA09001	5
*1K600-740	124	LCD窓 LCD window	1	1B998-069	9	○△	FCA09001	5
*1K610-750	117	フィルム押え Back door film roller arm	1	1B999-125-1	9	○△	FCA09001	5
*1K611-200	412	押え板 Retainer plate	1		1	○	FCA09001	5
*1K611-391-1	508	ギア押え板 Gear retainer plate	1		8	○	FCA09001	5
*1K625-068	109	パトローネ窓 Patorone window	1	1B999-125-1	9	○△	FCA09001. FCA09202	5
1K660-106	131	本体 Body die-casting	1		1	○	現品交換 FCA09001 RP-9110	1
*1K680-809	115	圧板 Pressure plate	1	1B999-125-1	9	○△	FCA09001. FCA09202	1
*1K680-858	717	圧接モールド Press-contact mold	1		7	○	FCA09001	5
*1K680-869	201	巻き上げ基板 Winding base plate	1		2	○	FCA09001	5
*1K680-871	705	LCD押え LCD retainer	1		4	○	FCA09001	5
*1K680-876	106	セルフ窓 Self-timer window	1	1B999-064	8	○△	FCA09001	10
*1K680-963-1 (1K680-963)	151	遮光板 Light-baffle plate	1		1	○	FCA09001	5
1K681-364	502	Fカバー Finder cover	1		3	○		1
△ 1K681-407		巻き戻しフック Rewind fork	1	1B998-084	2	○△	サ技No. サ95-05 RP-9522	5
1K999-037-2	129	底カバー Bottom cover	1		10	○	NO入り部品	1
*1K999-050		ズームレバー軸 Shaft. zoom lever	1			○	FCA09001	10

Change page (差し替え) △×1

-P 6・TW Zoom 35 <D>80- RP-INF. NO. 9522

MAR. 3. 1995



部品表 Parts List

FCA09002-R. 3288. A

部品番号 Part No.	補助番号 Ckt. No.	名称 Name	1台分 個数 Pcs. Per Unit	部組品番号 Assembly	参照 図番 Fig.	販売 区分 Term of Delivery	備考 Remarks	要求 単位 Qty per order
*1S125-029	1008	トランジスタ Transistor (2SA1363F)	3	1S014-007-2	4	○△	FCA09001	5
*1S205-044	1006	IC 1 IC (M50930-108FP)	1	1S014-007-2	4	○△	FCA09001	5
*1S210-011	1007	IC 2 IC (M51067FP)	1	1S014-007-2	4	○△	FCA09001	5
*1S260-034	1011	LED (赤) LED (Red)	1	1S014-007-2	4	○△	FCA09001	5
*1S260-035	1012	LED (緑) LED (Green)	1	1S014-007-2	4	○△	FCA09001	5
*1S268-011	1010	LCD LCD	1		4	○	FCA09001	5
*1S422-022	125	電池 SW. 裏蓋 SW. Battery SW. Back door SW.	2		2	○	FCA09001	5
*1S705-097-3 (1S705-097)	1002	サブフレキ * Sub F.P.C	1		7	○	FCA09001	5
*1S705-099-1 (1S705-099)	1009	ズーム SWフレキ * Zoom SW. F.P.C	1		1	○	FCA09001	5
*1S758-016	411	圧電ゴム Piezoelectric rubber	1		1	○	FCA09001	5
*1S758-017	706	ファンクション SW Function SW	1		4	○	FCA09001	5
*1S758-018-1 (1S758-018)	708	ゼブラコネクター LCD connector	1		4	○	FCA09001	5
*1S999-030		Xe管 Xenon-lamp	1	1B060-385	3	○△	FCA09001	5
*1S999-031 <i>1S999-073</i>	<i>D15</i>	発振トランス Transformer	1	1B060-385	3	○△	FCA09001 <i>9255</i>	5
*1S999-032		トリガーコイル Trigger coil	1	1B060-385	3	○△	FCA09001	5
<i>1S999-072</i>	<i>20</i>	<i>SHUTTER FPC</i>				<i>○△</i>	<i>RP-9116</i>	

部品表 Parts List

FCA09002-R. 3288. A

部品番号 Part No.	補助番号 Ckt. No.	名称 Name	1台分 個数 Pcs. Per Unit	部組品番号 Assembly	参照 図番 Fig.	販売 区分 Term of Delivery	備考 Remarks	要求 単位 Qty per order
*1G118-007	G15	G15	1		3	○	FCA09001	1
*1G308-013	G11	G11	1		3	○	FCA09001	1
*1G318-009	G12	G12	1		3	○	FCA09001	1
*1G318-010	G13	G13	1		3	○	FCA09001	1
*1G725-002	G14	G14	1		3	○	FCA09001	1
*1G780-004	G18	A E窓 AE window	1	1B998-064 1B998-065	8	○△	FCA09001	5
*1G780-005	G19	A F窓 AF window	1	1B998-064 1B998-065	8	○△	FCA09001	5
*1G780-006	G20	プロテクター Diffuser	1	1B998-064 1B998-065	8	○△	FCA09001	5
1G780-010	G21	接眼窓 Eyepiece lens	1	1B998-069	9	○△		5

Change page(差し替え)

MAR. 3.1995



部組品表 Assembly List

FCA09002-R. 3288. A

部組品番号 Assembly No.	補助番号 Ckt. No.	名称 Name	1台分 個数 Pcs. Per Unit	大部組品番号 Main assembly No.	参照 図番 Fig.	備考 Remarks	要求 単位 Q'ty per order
*1B001-799	B107	電池蓋 Battery chamber led	1		10	FCA09001	5
△ *1B001-800-1	B224	巻戻しフォーク部組	1		2	FCA09001 サ技No. サ95-05 RP-9522	5
△ *1B998-084		Rewind fork unit					
*1B060-353-3	B496	DX接点 DX contact unit	1		1	FCA09001	5
*1B060-385	B351	スピードライト Speed light unit	1		3	FCA09001	5
*1B060-386-2 (1B060-386)	B481	F検ユニット Film detection contact unit	1		1	FCA09001	1
*1B240-062-1 (1B240-062)	B714	リリースSW Release SW. unit	1		7	FCA09001	5
*1B277-027-2	B220	遊星ギア Planetary gear unit	1		2	FCA09001	5
*1B999-122-1	B241	フィルム押え Body-side film roller unit	1		2	FCA09001	5
*1B999-125-1	B108	裏蓋 Back door unit	1		9	FCA09001	1
*1B999-169-1	B234	モーター W/R motor unit	1		3	FCA09001	5
1B998-064	B101	前カバー Front cover unit	1		8		1
1B998-069	B123	後カバー Rear cover unit	1		9		1
*1S014-007-2 (1S014-007-1)	B1001	メインFPC Main F.P.C unit	1		4	FCA09001	1
FCA09102 1B998-065	B101	前カバー Front cover unit	1		8		1

Change page (差し替え) △×2

-P10・TW Zoom 35 <D>80- RP-INF. NO. 9522

MAR. 3. 1995



部品表 Parts List

FCA09002-R. 3288. A

部品番号 Part No.	補助番号 Ckt No.	名称 Name	1台分 個数 Pcs. Per Unit	部組品番号 Assembly	参照 図番 Fig. No.	販売区分 Term of Delivery	備考 Remarks	要求単位 Qty per order
*1601 (1K670-102)		外ヘリコイド Outer helicoid	1		6	○	FCA09001	1
*1604 (1K535-317)		内ヘリコイド Inner helicoid	1		5	○	FCA09001	1
*1605		回転筒 Turning tube	1		5	○	FCA09001	1
*1608		3群付勢ばね Spring. 3rd group	1		5	○	FCA09001	5
*1609		3群カムピン Cam pin (3rd group)	3		5	○	FCA09001	5
*1612		調整レバー Adjustment lever unit	1		5	○	FCA09001	5
*1613		回転筒押えネジ環 Turning tube retaining ring	1		5	○	FCA09001	5
*1615		回転筒付勢ばね Spring. turning tube	1		5	○	FCA09001	5
*1623		フォーカシングヘリコイド Focusing helicoid	1		5	○	FCA09001	1
*1625		G1押え環 Retainer ring. G1	1	0622	5	○△	FCA09001	5
*1626		フォーカシングリング Focusing ring	1	0622	5	○△	FCA09001	1
*1628		1群付勢ばね Spring. 1st group	1		5	○	FCA09001	5
*1629 (1K116-577)		遮光シート Light-baffle sheet	1	*0621 (1B060-391)	5	○△	FCA09001	5
*1631		キーカム Key cam	1		6	○	FCA09001	1
*1632		直進キー Linear key	1		6	○	FCA09001	5
*1633		FPC支持板 FPC support plate	1	*0621 (1B060-391)	5	○△	FCA09001	5

Change page (差し替え)

- P11・TZ 35-80-

RP-INF. NO. 9524

MAR. 10. 1995



部品表 Parts List

FCA09002-R. 3288. A

部品番号 Part No.	補助番号 Ckt No.	名称 Name	1台分 個数 Pcs. Per Unit	部組品番号 Assembly	参照 図番 Fig. No.	販売区分 Term of Delivery	備考 Remarks	要求単位 Q'ty per order
*1634		ブラシ台 Brush holding plate unit	1		6	○	FCA09001	5
*1638		接点 Contact	1		6	○	FCA09001	5
*1639 (IK116-854)		植毛シート Flacked sheet	1	*0621 (1B060-391)	6	○△	FCA09001	5
*1643		ギア1 Gear 1	1		6	○	FCA09001	5
*1644		ギア2 Gear 2	1		6	○	FCA09001	5
*1645		ギア4 Gear 4	1		6	○	FCA09001	5
*1646		ギア3 Gear 3	1		6	○	FCA09001	5
*1650 (IK116-615)		遮光モルト Light-baffle sponge	1		5	○	FCA09001	5
*1651		ギア押え板 Gear retainer plate	1		6	○	FCA09001	5
*1652		モーター押え板 Moter retainer plate	1		6	○	FCA09001	5
*1653 (IK116-676)		モーターゴム 0.3t Motor rubber	1		6	○	FCA09001	5
△ △		*1654 *IK116-677-3	1	*0621 (1B060-391)	5	○△	FCA09001 RP-9524	5
*1661		鏡筒 Lens barrel tube	1		5	○	FCA09001	1
*1662		前押え板 Front retainer plate	1		5	○	FCA09001	5
*1664		バリア上 Upper lens cover	1		5	○	FCA09001	5
*1665		バリア下 Lower lens cover	1		5	○	FCA09001	5

Change page (差し替え) △×2

- P 1 2 · TZ 35-80 -

MAR. 10. 1995

RP-INF. NO. 9524



部品表 Parts List

FCA09002-R. 3288. A

部品番号 Part No.	補助番号 Ckt No.	名称 Name	1台分 個数 Pcs. Per Unit	部組品番号 Assembly	参照 図番 Fig. No.	販売区分 Term of Delivery	備考 Remarks	要求単位 Q'ty per order
*1667		駆動板 Driving plate	1		5	○	FCA09001	5
*1668 (1K225-167)		バリア開きばね Lens cover opening spring	1		5	○	FCA09001	5
*1669 (1K230-245)		バリア閉じばね Lens cover closing spring	2		5	○	FCA09001	5
*1670		駆動レバー Lens cover driving lever	1		5	○	FCA09001	5
*1684		テープ Tape	1	*0621 (1B060-391)	5	×	FCA09001 RP-9110 TA-0012	5
*1685		テープ Tape	1	*0621 (1B060-391)	5	×	FCA09001 RP-9110 TA0006S	5
△ *1004 (1S705-098)		エンコーダフレキ Encoder F.P.C	1	*0602 (1B060-387)	6	○△ J ○	FCA09001 RP-9582	5
*9671 (1K010-167)		Screw	1		5	○	FCA09001	10
*9803 (1K010-111)		Screw	4		5.6	○	FCA09001	10
*9804 (1K010-112)		Screw	14		5.6	○	FCA09001	10
*9805 (1K010-114)		Screw	2		6	○	FCA09001	10
*9806 (1K010-135)		Screw	3		6	○	FCA09001	10
*9808 (1K010-112)		Screw	2		5	○	FCA09001	10
*9810 (1K010-151)		Screw	2		6	○	FCA09001	10
*9811 (1K010-110)		Screw	1		5	○	FCA09001	10
*9824 (1K010-137)		Screw	1		6	○	FCA09001	10
*9829 (1K130-406)		Screw	1		5	○	FCA09001	10
*1801		G1	1	0622	5	○△	FCA09001	1

Change page (差し替え) △×1

SEP. 26. 1995



データバック編

目次

仕様	-----	B 1
チェック方法	-----	B 2
展開図	-----	B 3
部品表	-----	B 4

DATA BACK

CONTENTS

Specifications	-----	B 1
Inspection	-----	B 2
Exploded Drawings	-----	B 3
Parts List	-----	B 4

Specifications

- Imprinting mode: Year-Month-Day, Month-Day-Year, Day-Month-Year,
Day-Hour-Minute and No imprinting.
- Imprinting duration:

ISO < 400	Approx.	60mS
400 ≤ ISO < 1600	Approx.	37mS
1600 ≤ ISO	Approx.	22mS
- Date & Hour: Displays from Jan. 1st, 1987
 {
 to Dec. 31, 2019
 (Last two figures are displayed for year)
 Adjustment in leap year and at the end of month are
 automatically made.
 Displays 0:00 - 23:59.
- Accuracy of clock: Monthly difference approx. 90sec.
- Power source: 3V lithium battery (CR2025)x1
- Dimensions: Approx. 137(W) x 73(H) x 61(D) mm
- Weight: Approx. 370g (without battery)

Inspection

1. Judgement of data imprinting signal.

Output of data imprinting signal can be confirmed by the tester.

1) Open the camera back door.

2) Turn off camera back SW.

3) Set the tester's range at DC 0.5V, and connect the tester to GND and D2 contacts.

1st data contact from left on body: GND

2nd data contact from left on body: D2(⊕)

4) If the signal is output, the needle of the tester moves for an instant when shutter is released.

Swing of the needle changes by three steps depending on the film speed.

2. Inspection of imprinting

1) Open the camera back door.

2) Paste the Scotch tape on the data imprinting window of the pressure plate.

3) Provide the ⊕-contact on the data back with the voltage of 3V Via resistor 330KΩ.

Left data contact on the data back: ⊕

Right data contact on the data back: GND

4) Be sure to inspect quickly because the lamp in data module remains lighting while voltage is given.

5) Observe the figures projected on the Scotch tape with a loupe.

The correct display is to be projected reversely on the tape.

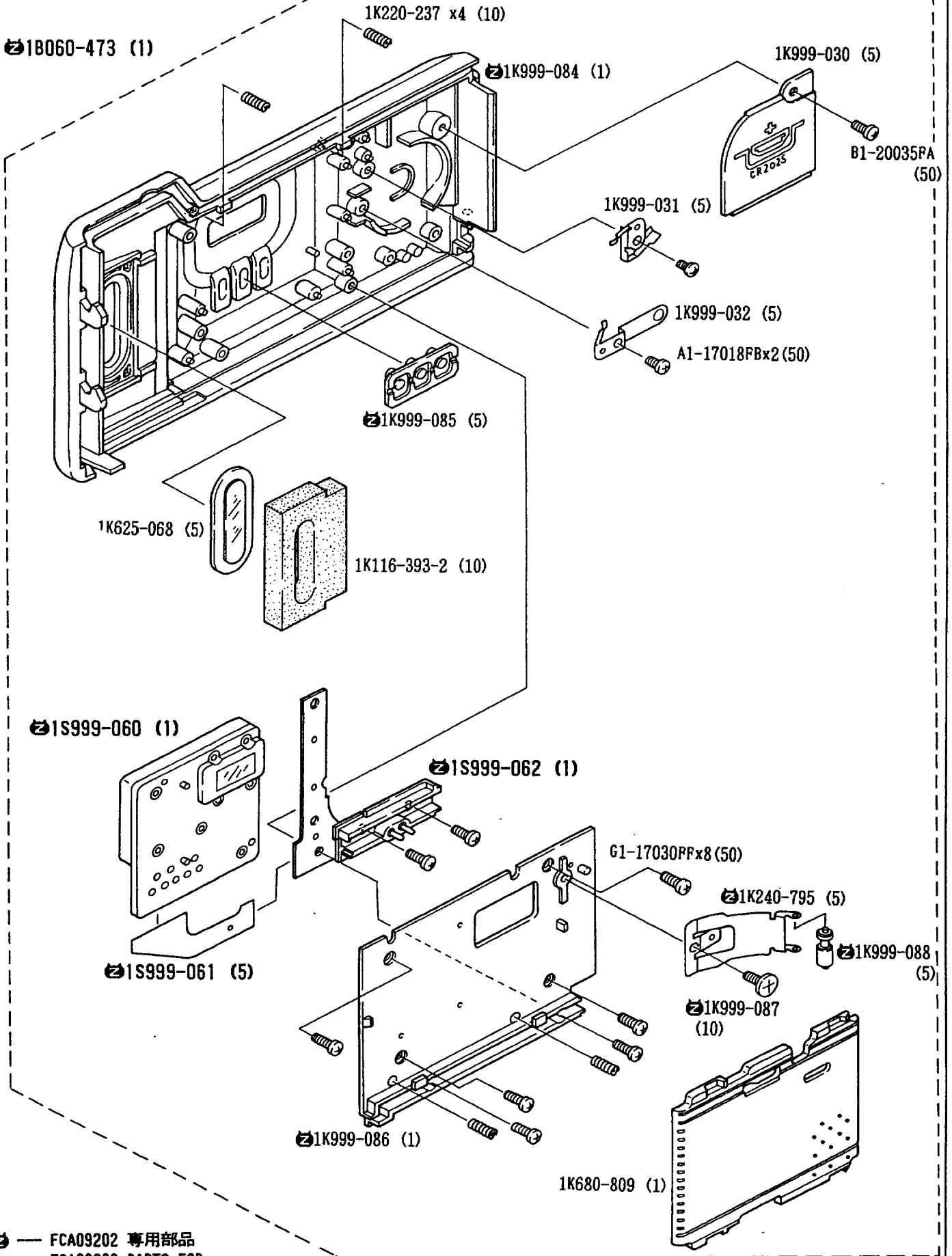

☞ — FCA09202 専用部品
FCA09202 PARTS FOR
EXCLUSIVE USE.

Fig. 1

部品表 Parts List

TW Zoom 35<▷85 QD

FCA09202-R. 3288. A

部品番号 Part No.	補助番号 Ckt. No.	名称 Name	1台分 個数 Pcs. Per Unit	部組品番号 Assembly	参照 図番 Fig.	販売 区分 Term of Delivery	備考 Remarks	要求 単位 Q'ty per order
*1K116-393-2 (1K116-393)	110	パトローネモルト Light-tight sponge, patrone window	1	1B060-473	1	○△	FCA09201, FCA09002	10
*1K220-237	116	圧板ばね Pressure plate spring	4	1B060-473	1	○△	FCA09201, FCA09002	10
1K240-795	117	フィルム押さえ Back door film rooller arm	1	1B060-473	1	○△		5
*1K625-068	109	パトローネ窓 Patorone window	1	1B060-473	1	○△	FCA09201, FCA09002	5
*1K680-809	115	圧板 Pressure plate	1	1B060-473	1	○△	FCA09201, FCA09002	1
*1K999-030	181	電池蓋 Battery chamber lid	1	1B060-473	1	○△	FCA09201	5
*1K999-031	131	D B 電池接片 + DB battery contact, +	1	1B060-473	1	○△	FCA09201	5
*1K999-032	132	D B 電池接片 - DB battery contact, -	1	1B060-473	1	○△	FCA09201	5
1K999-038-2	129	底カバー Bottom cover	1		10	○	NO入り 2~	1
1K999-084	300	D B 裏蓋基板 Comera back	1	1B060-473	1	○△		1
1K999-085	301	スイッチゴム A Switch rubber A	1	1B060-473	1	○△		5
1K999-086	302	D B. 内カバー Inner cover plate	1	1B060-473	1	○△		1
1K999-087	303	フィルム押さえネジ Screw	1	1B060-473	1	○△		10
1K999-088	304	フィルムローラー Back door film roller	1	1B060-473	1	○△		5

