

Instruction manual for TEMPERATURE CALIBRATOR TC305/TC303



Dear user,

We have made every effort to ensure the accuracy of the contents of this manual. Should any errors be detected, we would greatly appreciate to receive suggestions to improve the quality of the contents of this manual.

The above notwithstanding, we can assume no responsibility for any errors in this manual or their eventual consequences.

We reserve rights to make modifications to this manual without any further notice.

For more detailed technical data about the TC305/TC303 temperature calibrator, please contact the manufacturer.

© Copyright 1998
OY BEAMEX AB
P.O. Box 5
68601 Pietarsaari
FINLAND
Tel +358 - 6 - 7840111
Fax +358 - 6 - 7840404
E-mail: sales@beamex.com
Internet: <http://www.beamex.com>

Front panel

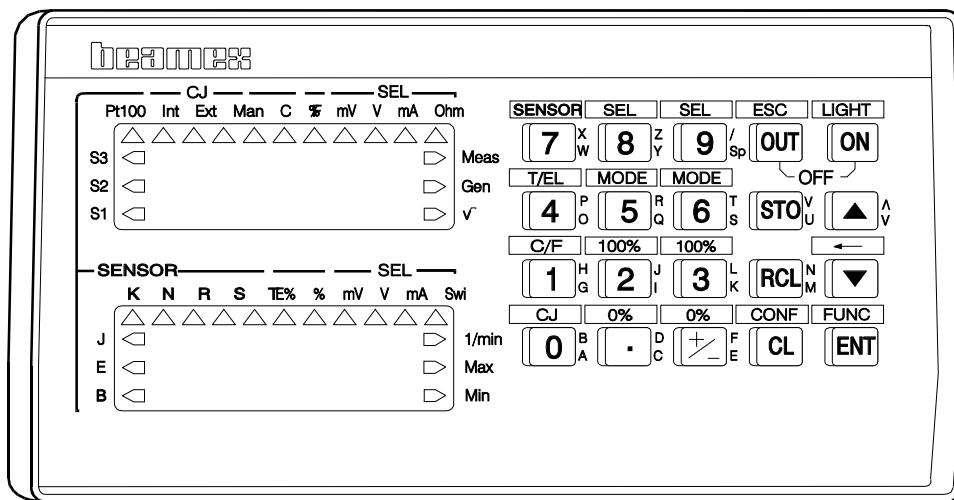

Connection panel

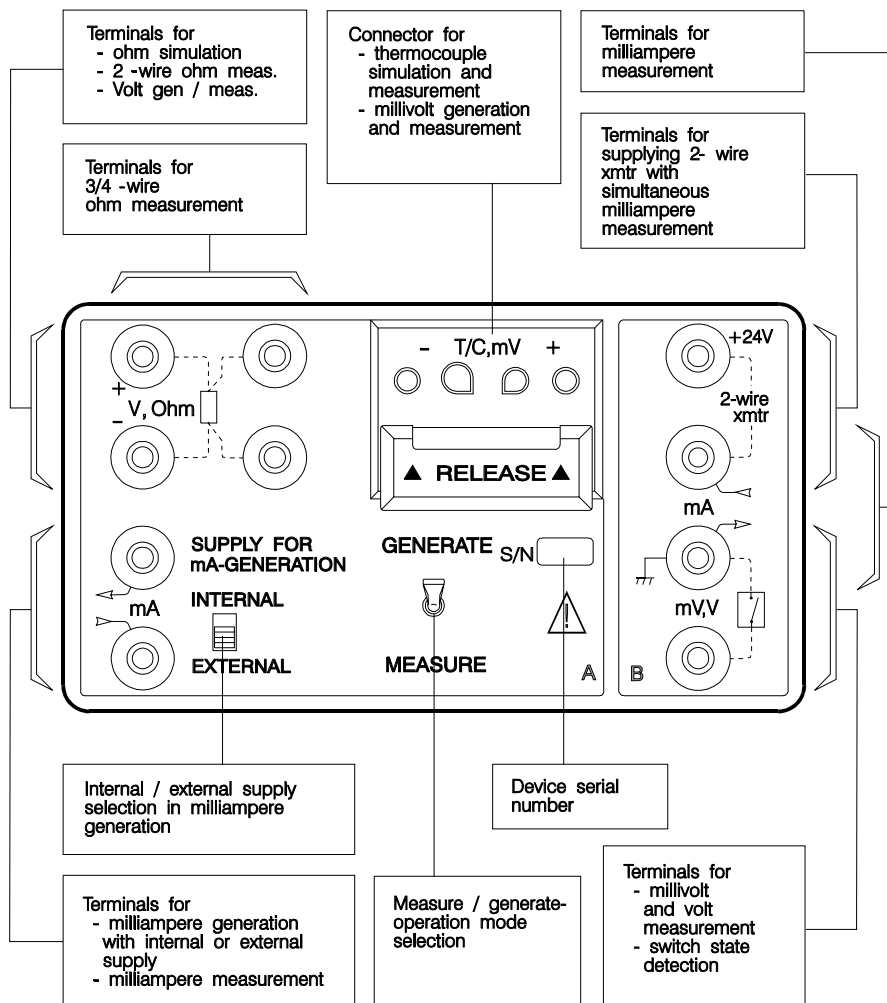

CONTENTS

PART A GENERAL

- 1 GENERAL OVERVIEW A - 1**
 - 1.1 Introduction A - 1
 - 1.2 Unpacking and inspection A - 2
 - 1.3 Carrying case and handle..... A - 2
 - 1.4 TC305/TC303 operational sections A - 3
 - 1.5 Safety A - 6

- 2 POWER, DISPLAY LIGHT A - 8**
 - 2.1 Power on/off A - 8
 - 2.2 Display light..... A - 8
 - 2.3 Batteries A - 8

- 3 CONNECTION PANEL A - 11**
 - 3.1 Overview A - 11
 - 3.2 Thermocouple connector block A - 12

- 4 OPERATION PANEL A - 14**
 - 4.1 Operation panel lay-out..... A - 14
 - 4.2 Common function key operations A - 16
 - 4.3 Keys for A-section operations..... A - 18
 - 4.4 Keys for B-section operations..... A - 19
 - 4.5 Displays..... A - 20

PART B BASIC OPERATIONS

- 1 MEASUREMENTS IN THE A-SECTION B - 1**
 - 1.1 General..... B - 1
 - 1.2 Thermocouple measurement..... B - 2
 - 1.2.1 Configuration for thermocouple measurement..... B - 2
 - 1.2.2 Wiring for thermocouple measurement B - 4
 - 1.3 Millivolt measurement B - 6
 - 1.4 RTD- and resistance measurement B - 7
 - 1.4.1 Configuration for RTD- and resistance measurement B - 7
 - 1.4.2 Wiring for RTD- and resistance measurement..... B - 8
 - 1.5 Milliampere measurement B - 9
 - 1.6 Volt measurement..... B - 10

- 2 SIMULATIONS AND GENERATIONS..... B - 11**
 - 2.1 General..... B - 11
 - 2.2 Entering generation/simulation values B - 12
 - 2.3 Thermocouple simulation B - 13
 - 2.3.1 Configuration for thermocouple simulation..... B - 14
 - 2.3.2 Wiring for thermocouple simulation B - 16
 - 2.4 Millivolt generation B - 20
 - 2.5 RTD- and resistance simulation B - 22
 - 2.6 Milliampere generation B - 24
 - 2.7 Voltage generation..... B - 26

- 3 MEASUREMENTS IN B-SECTION B - 27**
 - 3.1 General..... B - 27
 - 3.2 Milliampere measurement B - 28
 - 3.3 Millivolt and volt measurement B - 29
 - 3.4 Testing switch contact operation B - 30

- 4 OTHER BASIC FUNCTIONS..... B - 31**
 - 4.1 Percentage and error displays..... B - 31
 - 4.2 Use of the Working Memory B - 34

- 5 SOFTWARE OPTIONS B - 35**

PART C CONFIGURATION AND FUNCTION MENUS

- 1 GENERAL..... C - 1**

- 2 CONFIGURATION MENU..... C - 2**
 - 2.1 Square rooting calculation C - 3
 - 2.2 Instrument function type..... C - 4
 - 2.3 User configurations C - 6
 - 2.4 Calibration points C - 7
 - 2.5 Set point delay C - 8
 - 2.6 Date and time..... C - 8
 - 2.7 Others..... C - 9
 - 2.7.1 User configurations and default configurations C - 10
 - 2.7.2 Temperature scale C - 11
 - 2.7.3 TC305/TC303 recalibration dates..... C - 12
 - 2.7.4 Use of Kelvin C - 12
 - 2.7.5 Date format C - 12
 - 2.7.6 Software version numbers C - 13
 - 2.7.7 Serial numbers C - 13
 - 2.7.8 Special sensor definition..... C - 14

- 3 FUNCTION MENU..... C - 16**
 - 3.1 Special measurements C - 17
 - 3.2 Ramp definition and generation..... C - 19
 - 3.3 Auto stepping definition and generation C - 20
 - 3.4 Switch testing C - 21
 - 3.5 Loading from and saving to the Data Memory C - 24
 - 3.6 Clearing of memory..... C - 25

PART D TCAL305 EXPANSION

- 1 GENERAL..... D - 1**

- 2 TC305/TC303 MEMORY D - 3**
 - 2.1 Working Memory D - 3
 - 2.2 TCAL Data Memory D - 4
 - 2.3 Use of memory areas..... D - 4

- 3 PHASES OF THE INSTRUMENT CALIBRATION..... D - 5**
 - 3.1 As Found test..... D - 6
 - 3.2 Adjustment D - 7
 - 3.3 As Left test D - 8

- 4 INSTRUMENT DATA D - 9**
 - 4.1 Instrument data from QCAL Software Database..... D - 9
 - 4.2 User entered instrument data D - 10

- 5 TESTING INSTRUMENT CALIBRATION D - 11**
 - 5.1 Loading data from Data Memory D - 11
 - 5.2 Pre-operations and Quick Store D - 13
 - 5.2.1 Start of the Quick Store function..... D - 13
 - 5.2.2 Temperature transmitters and electrical converters..... D - 16
 - 5.2.3 Indicators and recorders D - 18
 - 5.2.4 Thermometers..... D - 20
 - 5.2.5 Temperature sensors..... D - 22
 - 5.2.6 Temperature transmitters with sensor..... D - 24
 - 5.2.7 Limit switches and thermostats without sensor..... D - 26
 - 5.2.8 Temperature limit switches (thermostats) with sensor..... D - 28
 - 5.2.9 TC305/TC303 measurement and generation ranges D - 30
 - 5.2.10 End of the Quick Store function..... D - 32
 - 5.3 Quick Examining calibration results D - 33
 - 5.4 Saving instrument and calibration data to Data Memory D - 34
 - 5.4.1 Saving As Found test results..... D - 34
 - 5.4.2 Saving As Left test results D - 35
 - 5.5 Clearing of memory..... D - 36

- 6 ENTERING INSTRUMENT DATA FOR QUICK STORE D - 37**
 - 6.1 General..... D - 37
 - 6.2 Temperature transmitters and electrical converters..... D - 38
 - 6.3 Indicators and recorders D - 39
 - 6.4 Thermometers..... D - 40
 - 6.5 Temperature sensors..... D - 41
 - 6.6 Temperature transmitters with sensor D - 42
 - 6.7 Electrical limit switches and temperature limit switches (thermostats)..... D - 44
 - 6.8 Temperature limit switches (thermostats) with sensor..... D - 46
 - 6.9 TC305/TC303 measurement and generation ranges D - 47

- 7 ENTERING AND DISPLAYING ALPHANUMERIC STRINGS D - 50**

GENERAL

1 GENERAL OVERVIEW

1.1 Introduction

TC305/TC303 is a portable precision thermometer/calibrator. It is specially designed for field operation. In addition, it is ideally suited for use in laboratories and maintenance shops.

TC305/TC303 can measure temperature by external sensors. Further, it can simulate temperature sensors. These features together with the good accuracy make it an excellent tool for calibration of temperature sensors and temperature measurement devices.

TC305/TC303 also measures and generates electrical signals. It contains two operating sections with galvanic isolation. One section may generate the input of the instrument under test. Simultaneously, the other section measures the output signal of the instrument. This feature makes TC305/TC303 effective in the calibration of temperature transmitters and electrical converters.

All this combined with several other features like ramping and stepping make TC305/TC303 a time saving and easy to use calibrator for calibration of electrical and temperature instruments.

The optional TCAL305 utility enables connection to calibration databases. It can download instrument data to the calibrator and upload calibration results to the database. You can use the database for scheduling, record keeping and documenting of calibrations.

The optional SWITCH utility uses a unique method for quick and accurate calibration of temperature switches (thermostats) and electrical limit switches.

The Sensor Modification option enables modification of standard temperature sensor definitions. Additional sensor definitions are also available as option.

1.2 Unpacking and inspection

At the factory each new TC305/TC303 passes a careful inspection. It should be free of scrapes and scratches and in proper operation order upon receipt. The receiver should, however, inspect the unit for any damage that may have occurred during transit. If there are signs of obvious mechanical damage, package contents are incomplete, or the instrument does not operate according to specifications, contact the purchasing sales office as soon as possible.

The standard accessories are as follows:

- * Carrying case
- * Charger
- * Test leads (4 pcs)
- * Instruction Manual
- * Service Manual
- * Calibration Certificate

If you have to return the instrument to the factory for any reason, use the original packing whenever possible. Include a detailed description of the reason for the return.

1.3 Carrying case and handle

In laboratories and maintenance shops TC305/TC303 is most convenient to use without carrying case. To remove the carrying case, open the carrying case flaps and the strap around the instrument. Pull out the instrument by lifting the rear of the instrument about an inch and the front of the instrument as much as possible. Turn the carrying handle downwards in front to support the instrument for better viewing. Install the instrument back to the carrying case in the reverse operations.

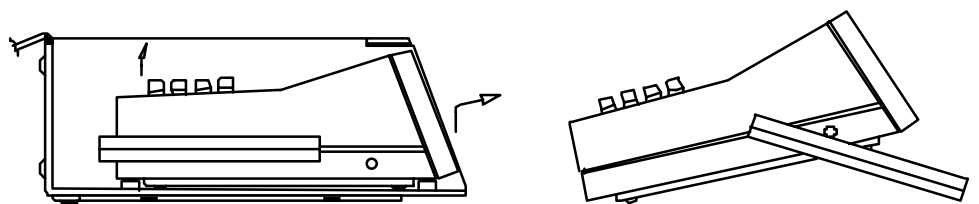

When using the instrument for operation in the field, keep it in the carrying case to protect the instrument. Further, during field operations the ambient temperature may vary suddenly. Sudden temperature changes may have a slight effect on the accuracy of the instrument. You can reduce this effect to a minimum by keeping the flaps of the carrying case closed whenever possible.

1.4 TC305/TC303 operational sections

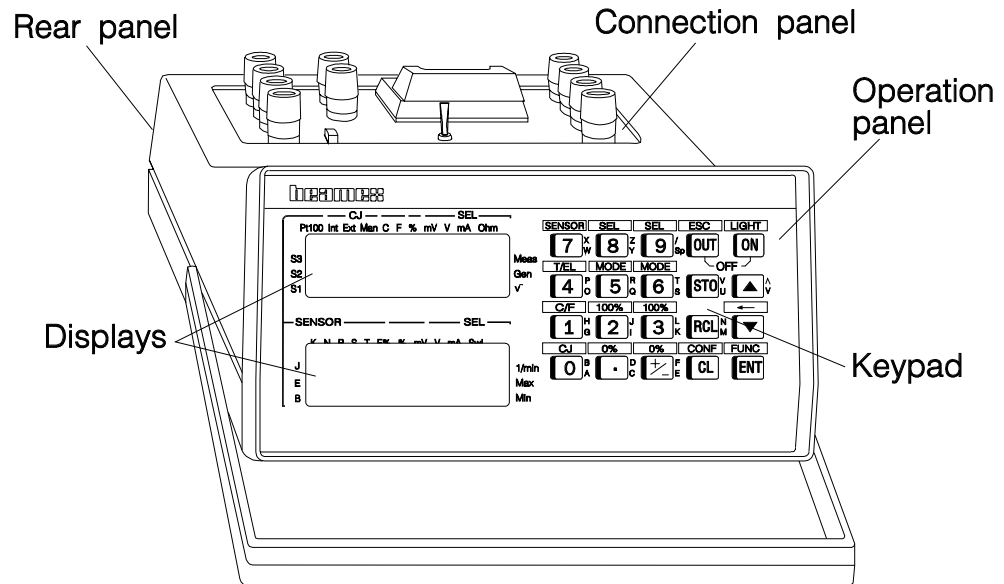

Section A

- * temperature measurement
- * sensor simulation
- * resistance simulation
- * measurement or generation of electrical signals.

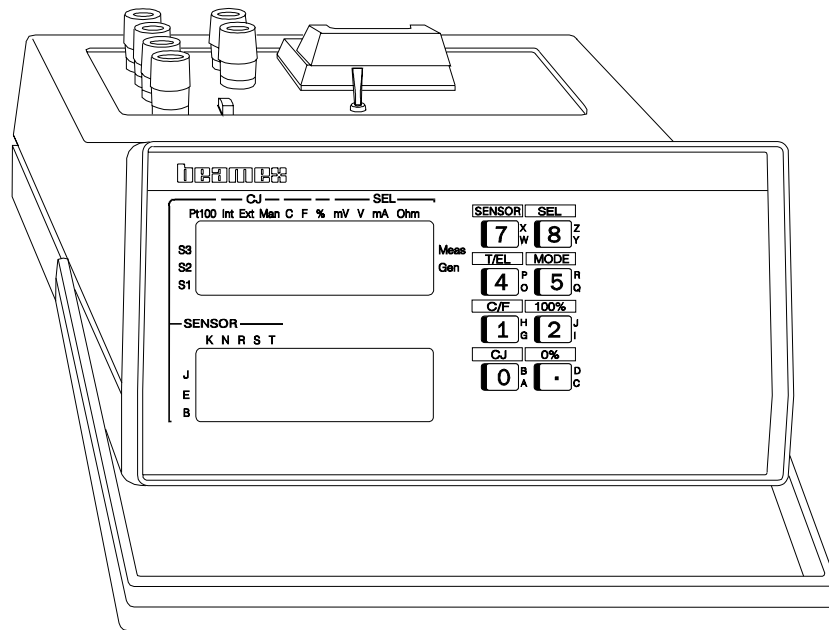

Section B

- * measurement of electrical signals
- * supplying a 2-wire transmitter (optional)
- * detection of the state (open or closed) of temperature switches (thermostats) and electrical limit switches.

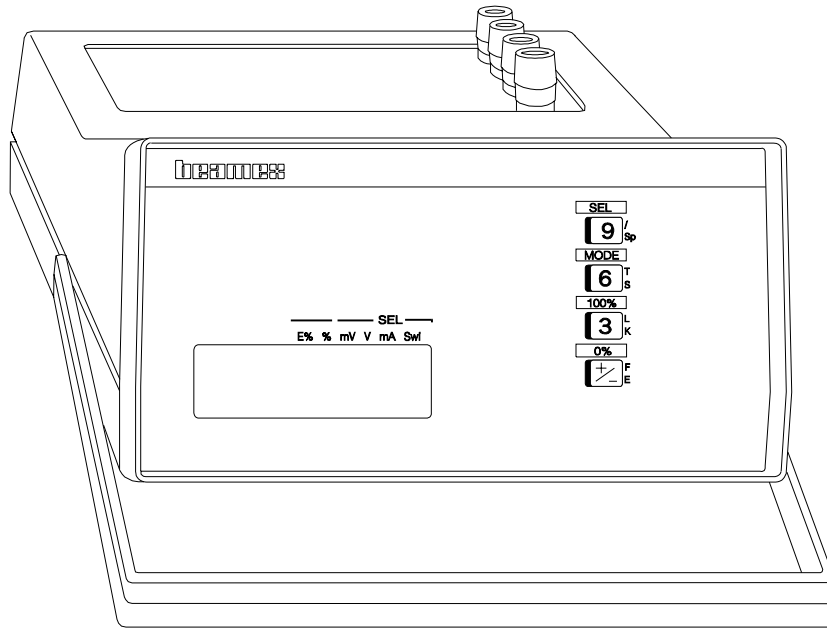

1.5 Safety

TC305/TC303 calibrator and its test leads are designed for connection to low, safe voltages only. Do not connect the calibrator or the leads to hazardous voltages.

The galvanic isolation between the sections A and B of the calibrator is for functional purposes only. Do not connect higher voltage than 50V between the sections.

Use the TC305/TC303 battery charger in a non-hazardous indoor location only and only with Beamex calibrators.

The measurement terminals are in connection to the calibrator chassis. Therefore, while measuring circuits that are in connection to ground, do not connect the chassis to ground by any other means. This could happen for instance by using the non-isolated computer interface (RS1) during the measurement.

If you use the TC305/TC303 computer interface during the measurement and/or generation operations, use an isolating computer interface adapter (RS2) to avoid ground loops, noise coupling and even circuit damage.

The measurement and generation terminals of TC305/TC303 are protected against over voltage and over current as far as it has been possible without affecting the accuracy. The circuits are designed so, that you can connect a voltage source 50VDC/2A between any terminals without damaging the device. However, long exposure to this kind of stress may affect the accuracy.

Voltages that can be output from TC305/TC303 terminals are below 30V. If you, however, connect together voltages from the A- and B-sections or if you connect external voltages to TC305/TC303, the resulting voltage may be high enough to be hazardous.

The Lead Acid batteries of TC305/TC303 contain toxic and corrosive electrolyte. They should be tight and safe within the specified temperature range. If you, however, detect any leak of the electrolyte, instantly replace the batteries. Do not touch the leaked electrolyte. It is very toxic and corrosive. In case of contact with skin, immediately flush with water. Consult a physician if burning or redness persist. If eye exposure occurs, flush with water for 15 minutes and consult physician. Clean carefully any electrolyte leak to avoid corrosion.

Discharge the used battery entirely before disposing it. The batteries contain lead compounds and they are classified as hazardous waste. Dispose the used batteries properly according to the local regulations.

Connect the new battery pack properly according to the label on the battery pack cover. Avoid short circuiting a charged battery, the short circuit current may cause burns to you, damage to the device or even fire. Notice, that also new replacement batteries are shipped in charged state.

Batteries always vent small amounts of oxygen and/or hydrogen during recharge. The vented gas mixture may be highly explosive, but normally it diffuses rapidly into the atmosphere. To avoid danger, use only the original charger and never recharge in a gas-tight container.

Sometimes it is necessary to use a portable radio transceiver while working with the calibrator. To prevent calibration errors caused by the radio frequency interference, keep the radio far (at least 1 meter) from the calibrator and the circuit under calibration while sending.

2 POWER, DISPLAY LIGHT

2.1 Power on/off

Switch TC305/TC303 on by pressing the **□ON** key at the operation panel. Hold the key pressed until the calibrator shows the message

**SELF
TEST**

TC305/TC303 tests now its internal operation. During the test sequence it sets the default configurations as explained in part C of this manual.

Switch TC305/TC303 off by pressing the **□OUT** and **□ON** keys simultaneously (= **OFF**).

TC305/TC303 automatically delays switching itself off, if it is carrying out an operation, which cannot be interrupted. However, also in that case TC305/TC303 immediately switches off the displays.

2.2 Display light

When TC305/TC303 is turned on, use the **□LIGHT[ON]** key to switch the display back light on and off. If you do not press any keys for two minutes or the battery is low (< 10%), back light switches off automatically. The automatic off switching of light is, however, disabled if the calibrator with fully charged batteries is connected to the charger.

2.3 Batteries

TC305/TC303 is supplied with rechargeable batteries and a battery charger.

When the charger is connected to TC305/TC303 and to the mains, TC305/TC303 automatically controls the charging and prevents overcharge. The batteries become fully charged in 10 hours, but it is recommended to keep the charger connected whenever possible. You can use TC305/TC303 also during recharge.

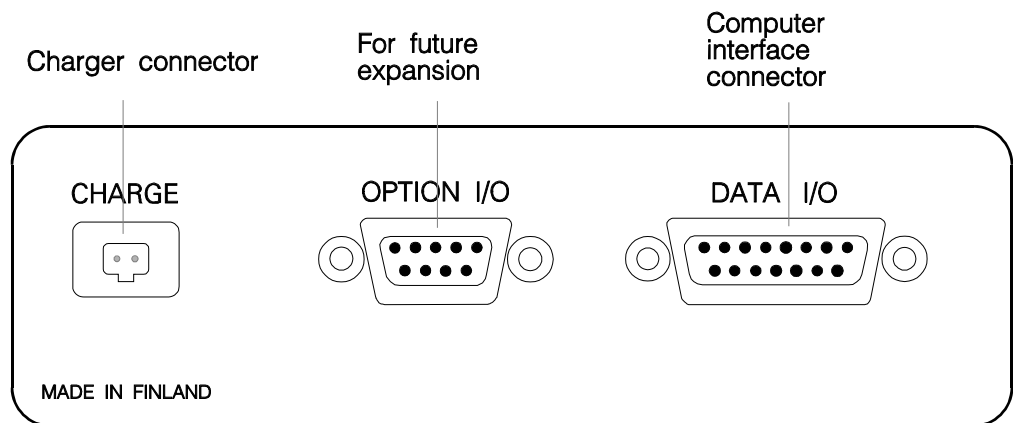

The TC305/TC303 maximum operation time without recharge varies from 10 hours to 30 hours depending on the generated output current and the usage of the optional 24V transmitter supply. A good average is about 24 hours.

When the batteries are almost empty, the text '**BATT.LO**' is periodically shown on the lower display. If the battery voltage sinks further, the control system switches the instrument off. This prevents erroneous readings caused by too low voltage and protects the batteries and the data in the memory.

TC305/TC303 takes a small current from the batteries for the memory and for the clock/calendar even when it is off. The self discharge of the batteries also decreases the remaining battery capacity. The self discharge rate increases at high ambient temperature. If you do not recharge the batteries in time, the voltage may go too low permanently damaging the batteries. With fully charged batteries this takes several months, but empty batteries may only last weeks.

Warning!

The Lead Acid batteries of TC305/TC303 contain toxic and corrosive electrolyte. They should be tight and safe within the specified temperature range. If you, however, detect any leak of the electrolyte, instantly replace the batteries. Do not touch the leaked electrolyte. It is very toxic and corrosive. In case of contact with skin, immediately flush with water. Consult a physician if burning or redness persist. If eye exposure occurs, flush with water for 15 minutes and consult physician. Clean carefully any electrolyte leak to avoid corrosion.

Discharge the used battery entirely before disposing it. The batteries contain lead compounds and they are classified as hazardous waste. Dispose the used batteries properly according to the local regulations.

Connect the new battery pack properly according to the label on the battery pack cover. Avoid short circuiting a charged battery, the short circuit current may cause burns to you, damage to the device or even fire. Notice, that also new replacement batteries are shipped in charged state.

Batteries always vent small amounts of oxygen and/or hydrogen during recharge. The vented gas mixture may be highly explosive, but normally it diffuses rapidly into the atmosphere. To avoid danger, use only the original charger and never recharge in a gas-tight container.

To avoid battery damage and loss of calibrator memory, recharge empty batteries within a few days.

Use the TC305/TC303 battery charger in a non-hazardous indoor location only and only with Beamex calibrators.

3 CONNECTION PANEL

3.1 Overview

The connection panel is on the top of TC305/TC303. Connections are easy to make and do not obstruct the displays or keypad.

The following figure briefly describes the terminals for electrical connections. The connections are described in details in part B of this manual.

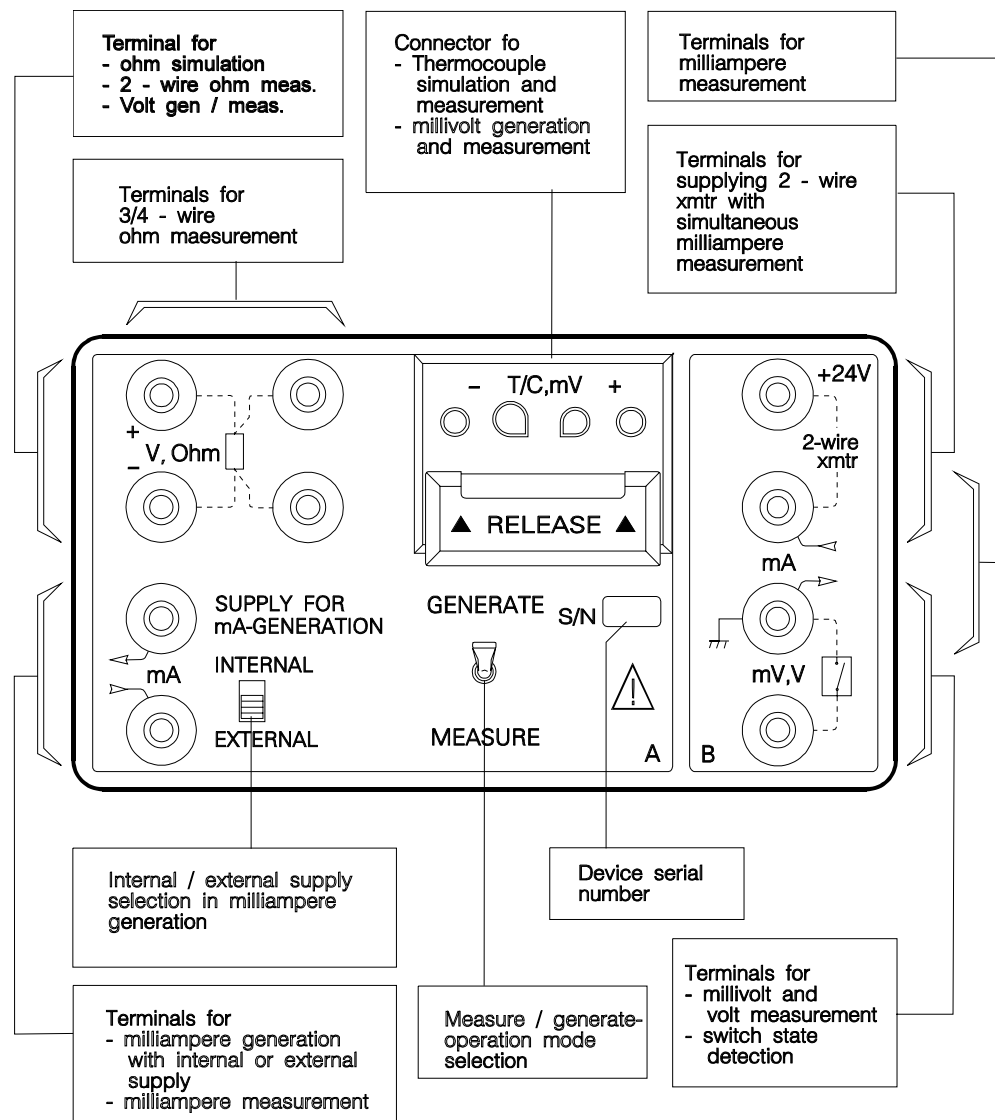

3.2 Thermocouple connector block

The thermocouple connector block is specially designed to be easy to use. Further, it keeps the errors in the reference junction compensation as small as possible. Accurate reference junction compensation is specially important in portable field calibrators.

A spring loaded clip pushes the wires or the thermocouple plug against the contact surfaces of the connector block. You can open the clip entirely by pushing the middle of the bar. With separate wires it is more convenient to open only one end of the clip by pushing either end of the bar.

If the thermocouple has a standard or miniature plug, connect the plug to TC305/TC303 according to the following drawing. Push the middle of the bar and put the plug into the centre holes. Pay attention to place the plug in right polarity, the thick pin (-) into the larger hole. When releasing the plug, push the bar again to open the clip and pull out the plug.

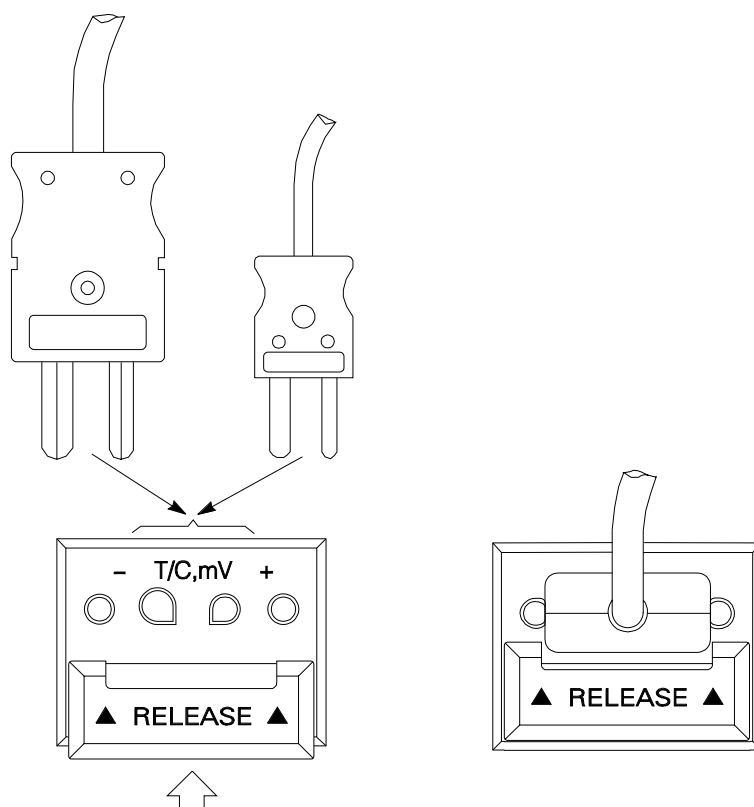

Connect stripped wires or wires with banana-plug to the outermost holes of the thermocouple connector block as shown in the following drawing. Push the respective end of the bar. Put the wire in the hole and release the bar. Make sure to connect the wires in right polarity as marked on the connector block.

When disconnecting the wires from the connector block, push the bar to open the holes before removing the wires.

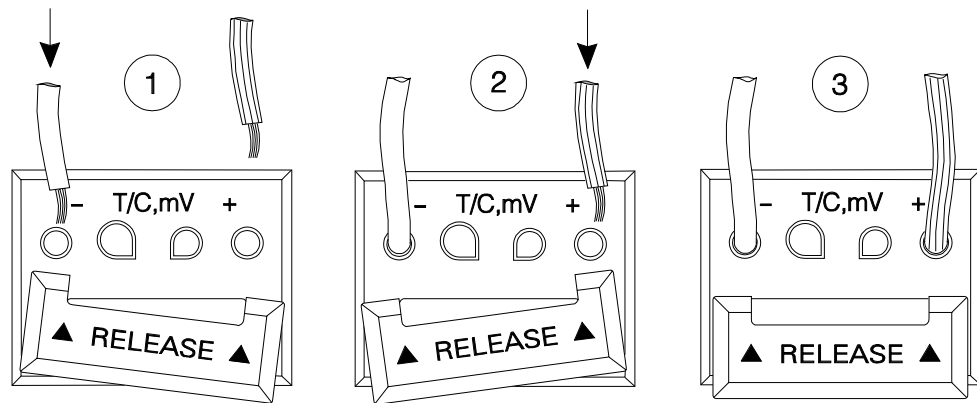

Notes:

The contact surface of the thermocouple connector block is gold-plated. To maximize the lifetime of the connector block, properly open the clip whenever placing or removing wires or plugs.

We have made a great effort to assure perfect isothermal operation of the thermocouple connector block. In the field, sudden temperature changes and gradients are common. Therefore it is a good practice to keep the carrying case flap in front of the connection panel closed whenever possible.

4 OPERATION PANEL

4.1 Operation panel lay-out

The operation panel of TC305/TC303 consists of two displays and 20 keys. Yellow and orange colors are used for the A-section key functions and display arrows. Blue color is used for the B-section functions. The respective colors are used also on the connection panel.

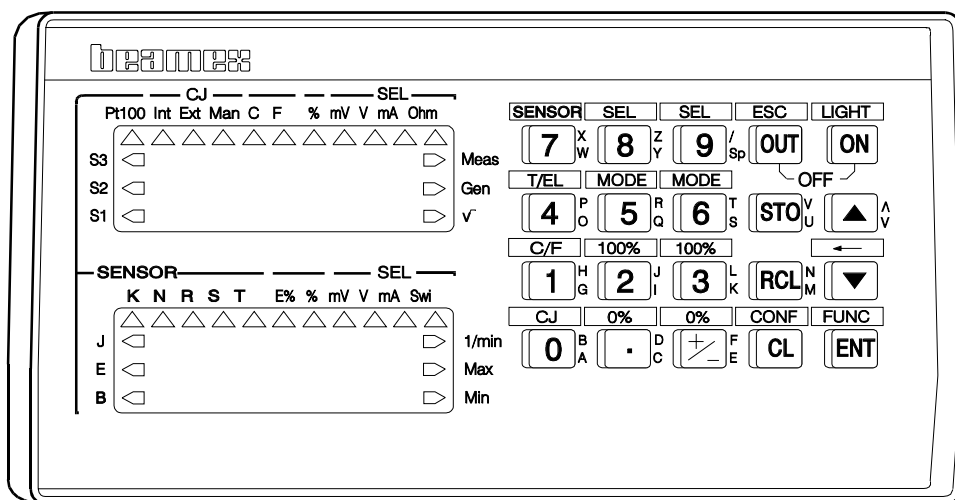

Each LCD-display consists of 6 large seven segment figures. Normally the figures are numbers, but in certain situations TC305/TC303 will also show text messages.

In addition to these figures the display contains 17 pointing arrows, 3 on each side and 11 on the top. The function of the arrows is to show the selected operation, sensor type, unit and some special selections valid for the time. You can change the selections via the keypad and the arrows show the valid condition.

The upper display is used mainly for the TC305/TC303 A-section readings and messages.

The lower display is used mainly for the B-section, but the selection pointers of thermocouple types B to T are, however, for the A-section.

Depending on the current operation, the keys may have three different basic functions:

- * function keys
- * numeric keys
- * alphabetic keys.

The numeric characters are marked on the keys and the functions above the keys. The alphabet is marked on the right side of the keys.

The keys are in four blocks. The basic functions of the keys in the two left columns operate with the A-section. The first column (yellow) is for temperature functions. The second column (orange) is for configuration of the A-section function and upper display mode. The centre column (blue) is for configuration of the B-section measurement function and lower display mode. The keys in the two right side columns (white) are common.

4.2 Common function key operations

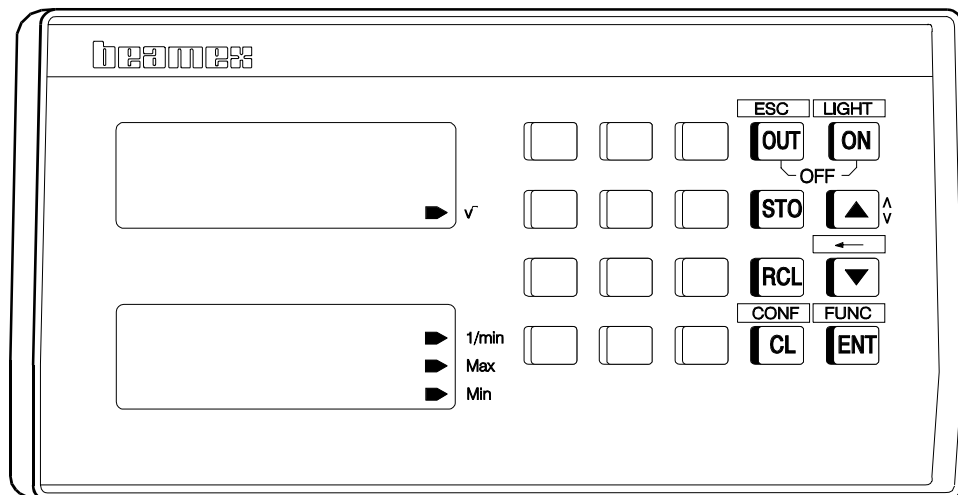

- OUT** When the MEASURE/GENERATE-switch is in the position GENERATE, this key switches between two states. This makes it possible to use the same keypad for device configuration and for entering of the values to be generated.
- ESC** When an operation - for instance setting of a value - is going on, pressing the key interrupts the operation and the system returns to the basic measure and generate operation.
- ON** Switch TC305/TC303 on, keep the key pressed until the text SELF TEST appears on the display.
- LIGHT** When TC305/TC303 is on, pressing the key toggles the display back light on and off.
- OFF** Pressing simultaneously the keys ON and OUT switches TC305/TC303 off.
- STO** Storing the display readings to the working memory.
- RCL** Recalling previously stored display readings from the working memory.

- ▲ In Generate-mode pressing this key increases the value for generation. Continuous pressing will progress the stepping speed.
- ▼ In Generate-mode pressing this key decreases the value for generation. Continuous pressing will progress the stepping speed.
- ↕ In text entering mode this key enables switching between numeric keys and the two sets of alphabets marked at the right side of the keys.
- ← While entering digits or characters, pressing the key deletes the last figure (= backspace).
- CONF While in basic measure and generate operation, this key enables configuration of some functions of the calibrator. For more details, see parts C and D of this manual.
- CL While entering digits or characters, pressing the key clears the display.
- FUNC While in basic measure and generate operation, this key enables carrying out of several special functions. For more details, see parts C and D of this manual.
- ENT While entering digits or characters, pressing ENT finishes the entering and the new value/string becomes valid. In CONF- and FUNC-menus, use ENT to accept the selection.

4.3 Keys for A-section operations

The left column of keys (yellow) contains the temperature related functions.

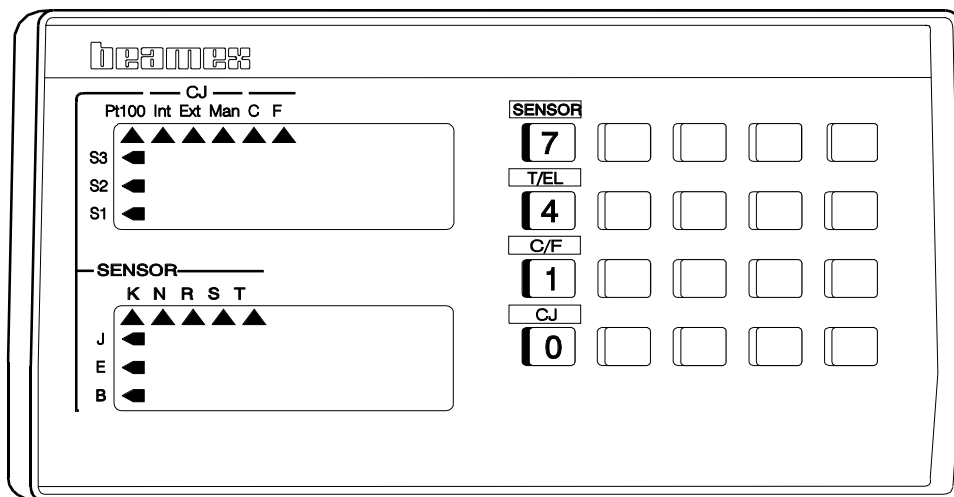

The keys in the second column (orange) are for input/output selection in the A-section and for the upper display mode.

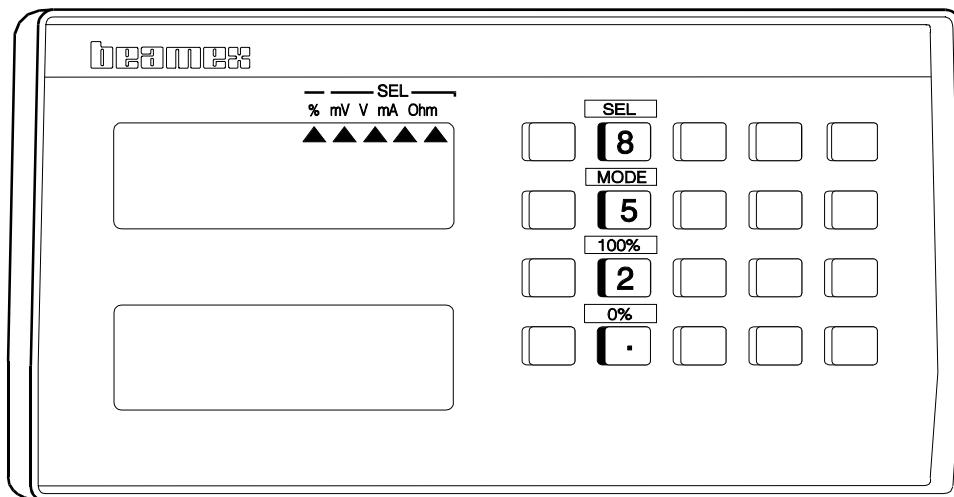

The use of these keys is explained in detail in part B of this manual.

4.4 Keys for B-section operations

The centre column keys (blue) are for input selection in the B-section and for the lower display mode.

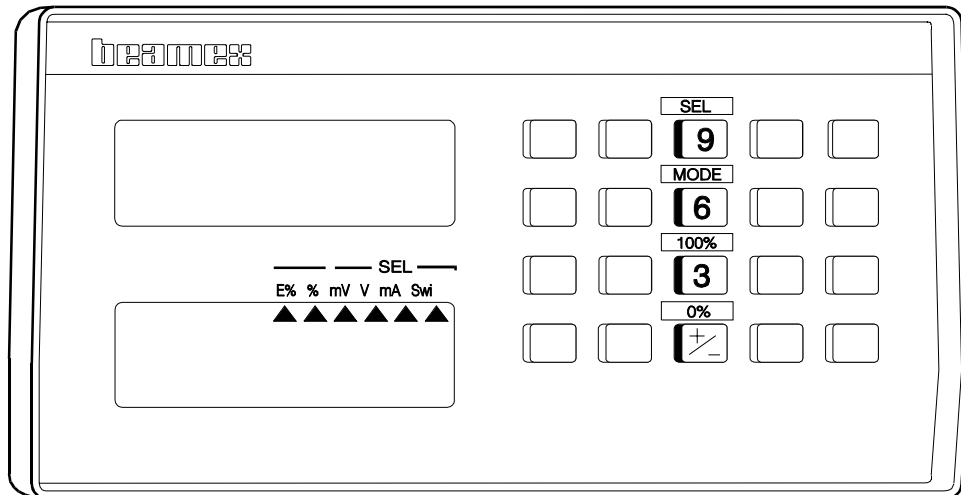

The use of these keys is explained in detail in part B of this manual.

4.5 Displays

The units of the measured or generated/simulated values are shown with arrows around the display.

The upper display readings may be in electrical units (mV, V, mA or ohm) or in temperature units °C or °F. In temperature mode the original electrical unit arrow disappears but another arrow shows the selected sensor type. Selection of percentage does not affect the other arrows, only an additional %-arrow appears and the reading converts into percent of the predefined range.

The lower display shows the measured value in electrical units (mV, V or mA). In %- or E%-mode, an additional arrow shows the selected mode. In %-mode the reading is in percent of the predefined range. In E%-mode the lower display shows the percentage error of the transmitter or converter output. With electrical switches and thermostats an arrow points the item 'Swi' and the display shows the switch state o(pen) or c(losed).

If the reading is outside the electrical range or outside the temperature range of the sensor type, one of the messages **HI.OFL** or **LO.OFL** flashes. The overflow message flashes once also when the user tries to enter an output value not within the range. If the percentage reading or the percentage error is not within the range $\pm 200\%$, the limit value flashes.

BASIC OPERATIONS

1 MEASUREMENTS IN THE A-SECTION

1.1 General

The A-section of TC305/TC303 calibrator measures temperature with several sensor types and simulates these sensors. It also measures and generates electrical signals. While calibrating electrical converters and transmitters, it generates the input signal for the instrument under test.

Measurement of other electrical signals than resistance is redundant, because the same measurements can also be carried out in the B-section.

The **MEASURE/GENERATE**-switch selects, whether this section is used for measurement or for generation/simulation.

Note:

All terminals in the A-section are isolated from the calibrator chassis. The B-section although is grounded and the sections are often connected together through external wiring or through the instrument under test.

Warning!

The galvanic isolation between the sections A and B of the calibrator is for functional purposes only. Do not connect higher voltage than 50V between the sections.

1.2 Thermocouple measurement

1.2.1 Configuration for thermocouple measurement

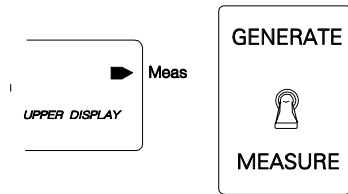

- a) The **MEASURE/GENERATE**-switch to the position **MEASURE**. An arrow in the upper display points to **Meas**.

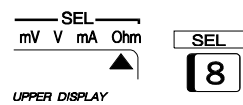

- b) Press the **SEL[8]**-key repeatedly until an arrow on the upper display points to **mV**.

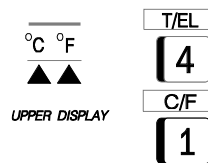

- c) Press the **T/EL[4]**-key. An arrow appears under either °C or °F showing that the shown readings are in temperature units instead of millivolts.
- d) If the temperature unit is not the required one, press the key **°C/°F[1]** to change it.

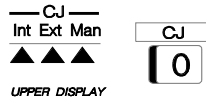

- e) Select the reference junction mode by pressing the key **□CJ[0]**. The arrow steps to the next choice by each pressing of the key CJ[0].

When the arrow points to **INT**, TC305/TC303 uses the thermocouple connector block as reference junction.

When the arrow points to **EXT**, TC305/TC303 measures the temperature of the external reference junction with external Pt100 probe connected to TC305/TC303.

When the arrow points to **MAN**, TC305/TC303 measures the temperature assuming that the reference junction is in a fixed temperature. For altering the reference junction temperature setting, see part C of this manual.

When none of the CJ arrows is shown, TC305/TC303 assumes that the reference junction is at 0°C.

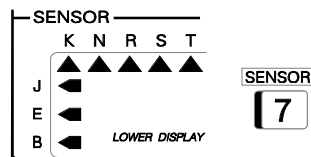

- f) Select the used thermocouple type by pressing the **□SENSOR[7]** key. The arrow pointing to the thermocouple type steps between types B, E, J, K, N, R, S and T. Set the arrow to point to the type of the used thermocouple.

1.2.2 Wiring for thermocouple measurement

Check that the thermocouple type corresponds to the selected type. If the thermocouple is not one of the predefined types, use millivolt measurement and convert to temperature manually. (Additional sensors can also be defined in the factory to the types S1, S2 and S3).

If you use extension or compensation wires, check that the wire types and connections are correct.

Check, which type of reference junction is in question. The following choices are available in TC305/TC303:

A) Internal reference junction (CJ = INTernal)

Connect the thermocouple directly or via extension or compensation wires to the TC305/TC303 thermocouple connector block. The reference junction (cold junction) locates inside of the TC305/TC303 thermocouple connector block. TC305/TC303 measures the internal temperature of the block and carries out the required correction.

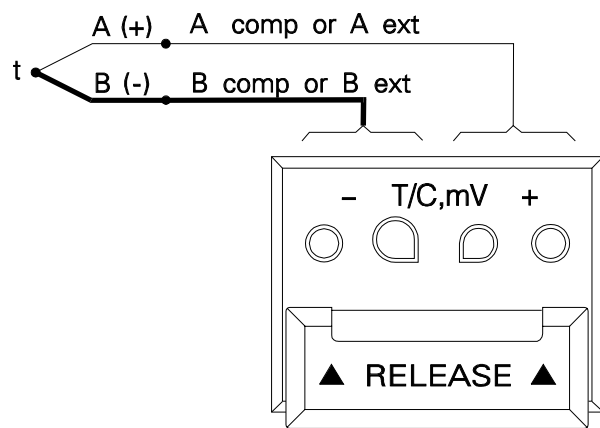

B) External reference junction (CJ = EXTernal)

The reference junction is external to TC305/TC303. Copper wiring is used between the TC305/TC303 thermocouple connector block and the external reference junction. TC305/TC303 measures the reference junction temperature with an external Pt100 probe and carries out the required correction.

For Pt100 wiring alternatives, see Chapter 1.4.2. Check, that the Pt100 probe is close to the reference junction(s) and protect them against sudden temperature variations.

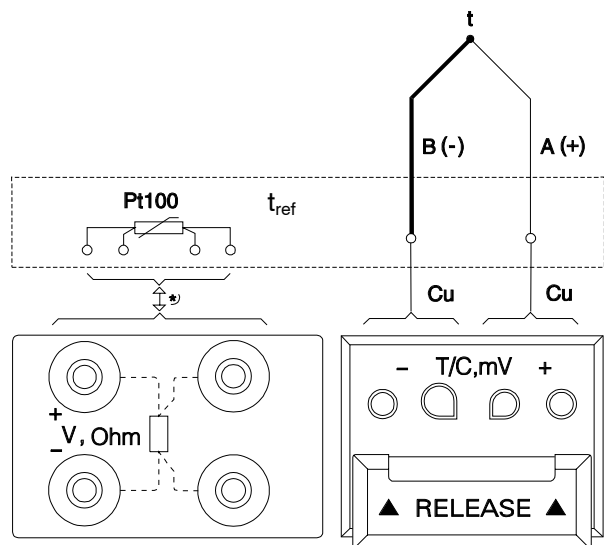

* See RTD-measurement for Pt100 wiring!

C) Manual reference junction compensation (CJ = MANual)

Measure the temperature of an external reference junction and control it to a fixed value or compensate with a compensation box. Use copper wiring between the TC305/TC303 thermocouple connector block and the external reference junction. In this case you have to give the actual or compensated reference junction temperature to TC305/TC303 from the keypad. See part C of this manual, how to check the TC305/TC303 reference temperature setting.

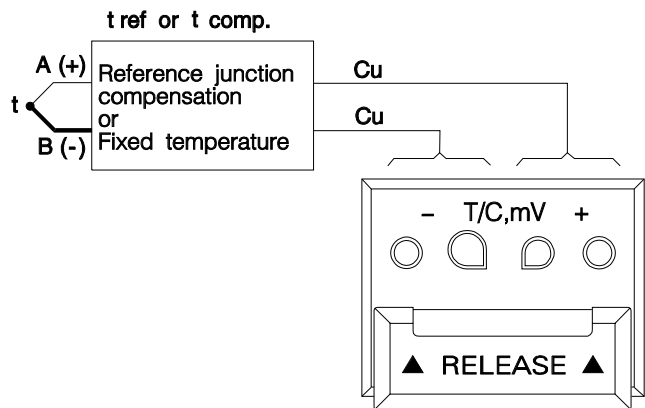

D) No reference junction compensation (CJ = none)

When there are no arrows on the CJ-section of the display, TC305/TC303 does not carry out any reference junction compensation. This is functionally equal with mode MANual, when the reference junction temperature is set to 0°C. This mode is specially practical in millivolt measurement and generation.

Error situations

With improperly connected or broken thermocouple the upper display may show random readings.

If the extension or compensation cable is of wrong type or polarity or if the selected CJ-mode is not in accordance with the used wiring, an extra error may occur. This error may vary from 0 to about +/-50°C depending on the type of the error. These are the most common errors in thermocouple measurements. You can only avoid them by careful checking of the used method and wiring.

The reference junction temperature compensation is limited to the range -20 to +100°C (with type B thermocouples 0 to +100°C). In internal CJ-mode reference junction temperature is limited to -10 to +60°C. If one of the limits exceeds, TC305/TC303 shows the respective text **CJ.LO** or **CJ.HI** as long as the error situation exists.

In external CJ-mode there is a message **CJ.OPEN**. It means that the reference junction Pt100 probe is open.

For checking the set or measured reference junction temperature, see part C of this manual. Checking the reference temperature may be helpful when you want to assure error free measurement.

1.3 Millivolt measurement

The following operations configure the A-section of TC305/TC303 for millivolt measurement:

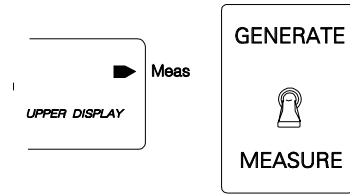

- a) The **MEASURE/GENERATE**-switch to the position **MEASURE**. An arrow on the upper display points to **Meas**.

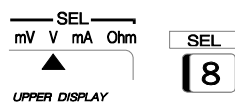

- b) Press the key **SEL[8]** repeatedly until an arrow on the upper display points to **mV**.

If you entered the millivolt measurement using the key SEL[8], the default CJ-mode is none (no reference junction compensation). This is always the right choice in other than thermocouple measurements.

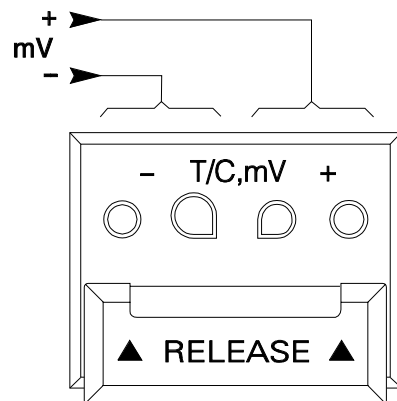

Connect the millivolt signal to the thermocouple connector block of TC305/TC303. Check that the polarity is as marked on the connector block.

Notes:

If you measure thermocouple output in millivolts, make sure that the right CJ-mode is selected. The thermocouple type arrow is shown in millivolt mode only with CJ-modes other than 'none'. In these modes, always select the right sensor type.

During thermocouple temperature measurement you can use the key T/EL[4] to display at the respective millivolt reading. When you enter the millivolt measurement through the T/EL-key, the selected CJ-mode of the temperature measurement is maintained in the millivolt mode, too.

1.4 RTD- and resistance measurement

1.4.1 Configuration for RTD- and resistance measurement

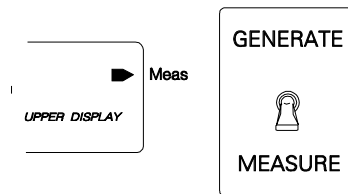

- a) The **MEASURE/GENERATE**-switch to the position **MEASURE**. An arrow on the upper display points to **Meas**.

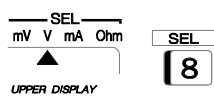

- b) Press the **SEL[8]** key repeatedly until an arrow on the upper display points to Ohm.

Carry out the items c) and d) in RTD-measurement only:

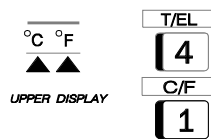

- c) Press the **T/EL[4]** key. The arrow at Ohm disappears and new arrows point to the temperature unit and **Pt100** on the upper display.

Pt100 is the only RTD-type implemented in TC305/TC303 as standard. Other types can be added as option to the special sensor types S1, S2 and S3. If additional types have been added, use the **SENSOR[7]** key to select the required type.

- d) If the temperature unit is not the required one, press the **°C/°F[1]** key to change the unit.

You can now read the measured resistance or temperature on the upper display as soon as you have properly connected the RTD or resistor.

1.4.2 Wiring for RTD- and resistance measurement

The wiring of the RTD or resistor can be any of those in the following figure. (Note that these are measurement wirings, in resistance simulation use the leftmost terminals only).

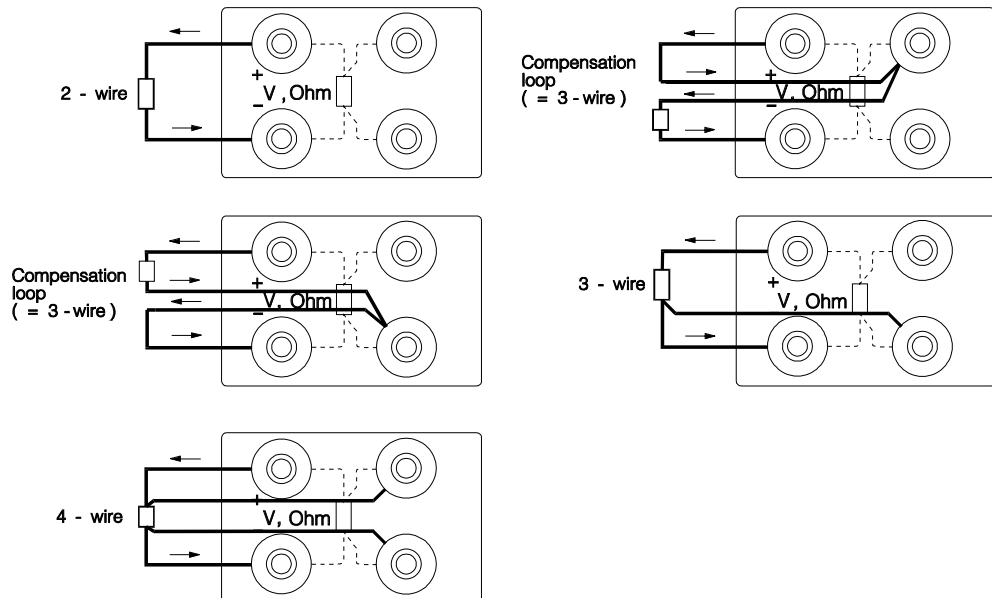

TC305/TC303 automatically checks the connection and the found connection type (**2-wire**, **3-wire** or **4-wire**) flashes on the display whenever selecting the ohm measurement or changing the wiring. The compensation loop is seen by the calibrator as 3-wire connection.

If the found resistance value is infinite or very high, the text '**OPEN**' is shown on the display. It means that the circuit is broken or the connection is wrong. Wrong connection may also cause erroneous reading, typically too low. If necessary, use the 2-wire ohm measurement to check the wiring before final connection.

Two main problems in RTD and ohm measurement are the effects of wiring resistances and thermovoltages in the resistance measurement circuit. If possible, use 4-wire connection to eliminate the effect of wiring resistance. The special resistance measurement sequence of TC305/TC303 eliminates perfectly the thermovoltages of the resistance measurement circuit.

1.5 Milliampere measurement

The following operations configure TC305/TC303 A-section for milliampere measurement:

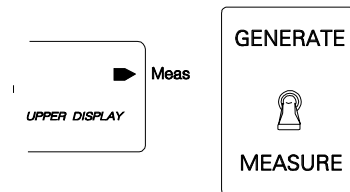

- a) The **MEASURE/GENERATE**-switch to the position **MEASURE**. An arrow on the upper display points to **Meas**.

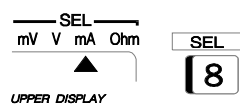

- b) Press the **SEL[8]** key repeatedly until an arrow on the upper display points to **mA**.

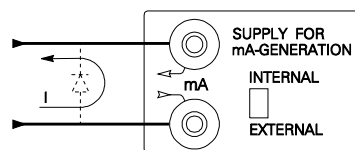

Make connections for the measurement. Check that the current polarity corresponds to the arrows on the connection panel. The mA-generation supply switch has no function in measurement mode. If you want to supply a 2-wire transmitter while measuring its output, use the B-section mA-measurement.

The impedance of the milliampere input is low enough (about 6 ohms) to enable current measurement parallel to a test diode in a 20mA circuit.

You can now read the measured current in milliamps on the upper display.

1.6 Volt measurement

The following operations configure TC305/TC303 A-section for voltage measurement:

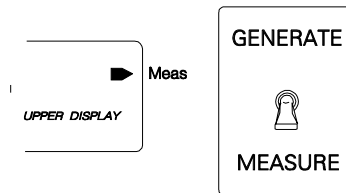

- a) The **MEASURE/GENERATE** switch to the position **MEASURE**. An arrow on the upper display points to **Meas**.

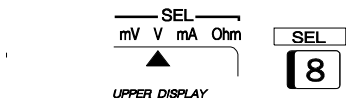

- b) Press the **SEL[8]** key repeatedly until an arrow on the upper display points to **V**.

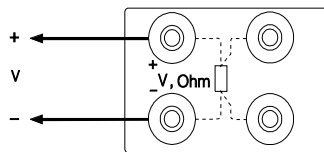

Make connections for the measurement. Check that the voltage polarity is as marked on the connection panel.

You can now read the measured voltage on the upper display.

2 SIMULATIONS AND GENERATIONS

2.1 General

The A-section of TC305/TC303 calibrator measures temperature with several sensor types or simulates the same temperature sensors. While calibrating electrical instruments, it generates the input signal for the instrument under test.

The **MEASURE/GENERATE**-switch sets the A-section of TC305/TC303 either in measurement operation or in generation/simulation operation.

Notes:

Whenever switching to the GENERATE-position, TC305/TC303 shows the message OUT.CNF. At this state the internal circuits are still in the measurement mode except the milliampere-section which outputs 0mA. This arrangement tries to prevent failures in the external circuits in case you accidentally turn the switch to the GENERATE-position during the MEASURE-operation. Carry out the necessary configurations in this state before entering the first output value. If you accidentally turned the switch, just turn the switch back to the MEASURE-position.

All terminals in the A-section are isolated from the calibrator chassis. The B-section is although grounded and the sections are often connected together through external wiring or through the instrument under test.

2.2 Entering generation/simulation values

After switching to the Generate-mode, the prompt **OUT.CNF** is shown on the upper display. In this state you can use the numeric keys to configure TC305/TC303 for the required operation. The functions of the keys are shown on the front panel above each key.

Carry out the configurations as explained later. Next press the **OUT[ESC]** key to exit the configuration. The text **OUT?** appears on the upper display.

Key in the value that you want to generate/simulate. The keyed figures are shown on the upper display. If you press a wrong key, correct it by pressing the key **<--** or press **CL** to start again from the beginning. Pressing **ENT** generates the entered value. The upper display is empty, while the TC305/TC303 output is settling. The generated/simulated value comes back to the upper display, when it is stable.

To alter the generated/simulated value, key in the new value and press **ENT**. If you only want to alter the already entered output a little, use the keys **Up** and **down**. A short press of these keys alters the output with the minimum amount. Keeping the key pressed causes a continuous ramp. At the beginning the ramp is slow, but the rate increases if you press long enough.

If the entered temperature is out of the range of the selected sensor type or the entered electrical value is out of the range of the calibrator, a message **LO.OFL** or **HI.OFL** flashes and the previous output remains unchanged.

If the resistance of the external circuit in thermocouple simulation, or millivolt/volt generation is very low (obvious short circuit), the message **OLOAD** flashes on the upper display until the load is reasonable. The same message flashes in milliamper generation, if the loop resistance is too high or infinite.

In resistance and RTD-simulation TC305/TC303 monitors the resistance measurement current. If the current is too high, it cannot simulate the right resistance value. In that case it shows the message **CUR.HI**. Respectively, if the measurement current is so low that it may affect the accuracy, it flashes the message **CUR.LO**.

2.3 Thermocouple simulation

TC305/TC303 is able to mimic the thermocouple at given temperatures. This property is called thermocouple simulation. It enables checking and calibration of temperature indicators, recorders, transmitters and other equipment related to temperature measurement with thermocouple probe.

In thermocouple simulation the original thermocouple is disconnected from the instrument under test and replaced with TC305/TC303. To the instrument under test TC305/TC303 appears as a thermocouple at the given temperature.

If you connect TC305/TC303 to an extension or compensation cable, an extra thermovoltage appears at the connection point. When properly configured, TC305/TC303 compensates for this extra thermovoltage.

2.3.1 Configuration for thermocouple simulation

The following operations configure TC305/TC303 for thermocouple simulation:

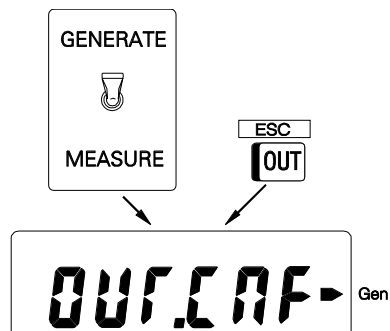

- a) The **MEASURE/GENERATE**-switch to the position **GENERATE**. An arrow on the upper display points to **Gen**.

If you just switched to the **GENERATE** position, the upper display shows the configuration state prompt **OUT.CNF**. If not, press the **ESC[OUT]** key to go to the configuration state.

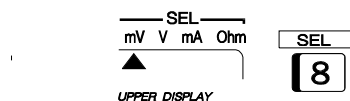

- b) Press the **SEL[8]**-key repeatedly until an arrow on the upper display points to **mV**.

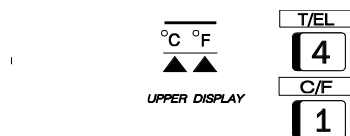

- c) Press the **T/EL[4]** key. An arrow under either °C or °F shows that the reading is in temperature units instead of millivolts.
- d) If the temperature unit is not the required one, press the **°C/°F[1]** key to change the temperature unit.

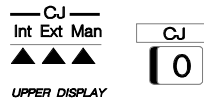

- e) Select the reference junction mode by pressing the key **□CJ[0]**. The arrow steps to the next choice by each pressing.

When the arrow points to **INT**, TC305/TC303 compensates for an extra thermovoltage in its thermocouple connector block.

When the arrow points to **EXT**, TC305/TC303 compensates for an external extra thermovoltage. Use an external Pt100 probe connected to TC305/TC303 for measurement.

When the arrow points to **MAN**, TC305/TC303 assumes that the reference junction is in a fixed temperature. See part C of this manual for checking or altering the reference junction temperature setting.

When none of the CJ arrows is shown, TC305/TC303 assumes that the reference junction temperature is 0°C.

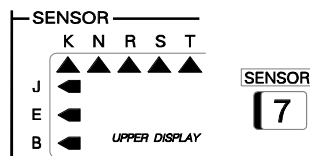

- f) Select the required thermocouple type by pressing the **□SENSOR[7]** key. The arrow pointing to the thermocouple type steps between types B, E, J, K, N, R, S and T.



When the configuration is done, exit the configuration state by pressing the key **□OUT[ESC]**. See Chapter 2.2, how to enter temperature simulation values.

2.3.2 Wiring for thermocouple simulation

Check that the instrument under test is set for the same thermocouple type as selected in TC305/TC303. If the type is not one of the predefined types, you should simulate in millivolt mode and convert from temperature to millivolts manually. Additional sensor types can also be defined in the factory to the types S1, S2 and S3.

If extension or compensation cables are used, check that the cable types and connections are correct.

Wire-wound thermocouple temperature indicators and recorders are calibrated with known loop resistance, commonly ten or twenty ohms. The required resistance of the conductors is usually marked on the device. When calibrating such a device, tune the loop resistance to the nominal value with an additional resistor.

Use the TC305/TC303 2-wire resistance measurement to tune the loop resistance of a wire wound device. Short circuit the measuring device for the time of resistance measurement. The resistance measurement may damage the device, if you do not install the short circuit.

Check, which reference junction mode you should use. One of the four TC305/TC303 CJ-modes should suit to all cases:

A) Internal reference junction (CJ = INTernal)

TC305/TC303 replaces the thermocouple in the measuring circuit. The extension or compensation cable of the measuring circuit is connected to the thermocouple connector block of TC305/TC303. TC305/TC303 measures the block temperature and compensates for the extra thermovoltage created due to the connection.

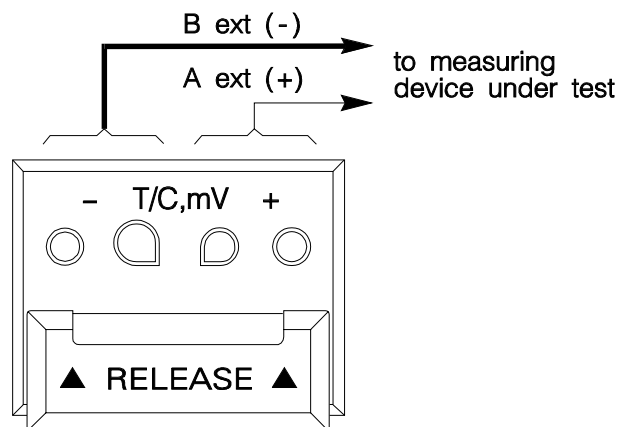

Another thermovoltage creates at the junction of the compensation or extension cable and the copper wiring of the instrument under test. This junction was also in the original wiring. The temperature of this junction should be taken care of by the circuits in the instrument under test.

B) External reference junction (CJ = EXternal)

Connect TC305/TC303 thermocouple connector block to the measuring circuit with copper wires. An extra thermovoltage creates (or the thermovoltage of the original junction disappears) at the point where these wires replace the original thermocouple. TC305/TC303 measures the temperature of this junction and compensates the thermovoltage. It uses an external Pt100 probe for the measurement.

For Pt100 wiring alternatives, see Chapter 1.4.2. Check, that the Pt100 probe is close to the junction to be compensated. Protect the whole arrangement against sudden temperature variations.

This wiring alternative is logical, but not very practical. Normally it is better to use extension or compensation wires instead of copper and select internal reference junction compensation.

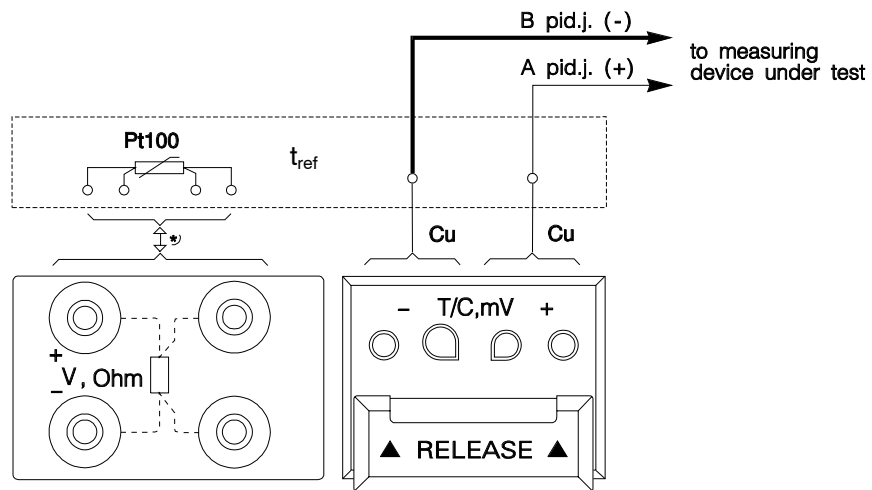

☞ See RTD measurement for Pt100 wiring!

C) Manual reference junction compensation (CJ = MANual)

In manual compensation mode, connect the instrument under test directly to the TC305/TC303 thermocouple connector block with copper wires.

Use the manual compensation mode, when there is no reference junction compensation in the measuring circuit or when the compensation is disconnected. Thus you test the instrument under test solely, without any error caused by reference junction compensation. In this case, check the operation of the possible reference junction compensation separately.

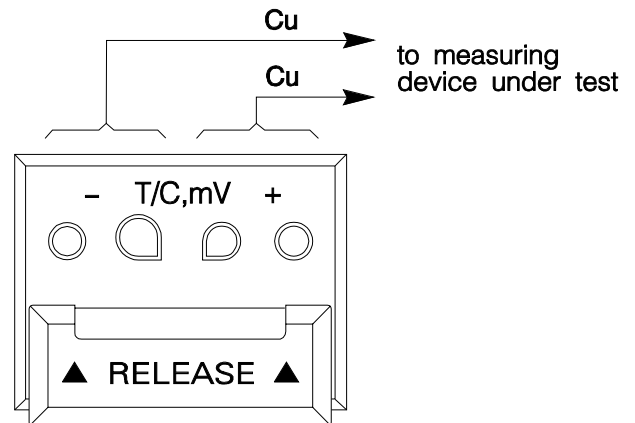

The measuring device under test must have been using either fixed reference junction temperature or a compensation box. The TC305/TC303 manual reference temperature setting should be that fixed temperature or compensation temperature. In most cases you can use the reference junction temperature setting 0°C. See part C of this manual, how to check the reference temperature setting.

D) No reference junction compensation (CJ = none)

When there are no arrows on the CJ-section of the display, TC305/TC303 doesn't carry out any reference junction compensation. This is functionally equal with mode MANual with the reference junction temperature set to 0°C. This mode is specially practical in millivolt measurement and generation.

Warning:

If you short circuit the thermocouple simulation output, TC305/TC303 tries to maintain the voltage by increasing the output current. If you then open the output again, the voltage is first too high, but returns quickly to the correct level. If this voltage peak could damage the components of the circuit, make sure that the circuit can not be shorted or protect the circuit against overvoltage. For the same reason, always enter 0°C output before connecting the circuit.

Error situations

If the connections in the loop are not made properly or if the loop is broken, the instrument under test may show random readings.

If the type or polarity of the extension or compensation cable is wrong or the selected CJ-mode is not in accordance with the used wiring, an extra error may occur. This error may vary from 0 to about $\pm 50^{\circ}\text{C}$ depending on the type of the error. These are the most common errors in calibration of thermocouple instruments. You can only avoid them by careful checking of the used method and wiring.

If the instrument under calibration uses voltage pulses to detect open sensor, prevent these pulses for the time of calibration. If TC305/TC303 detects these pulses, it tries to compensate for them, which could cause unstable output. Refer to the service manual of the instrument under calibration, how to prevent these open sensor detection pulses.

The reference junction temperature compensation is limited to the range -20 to $+100^{\circ}\text{C}$ (with type B thermocouples 0 to $+100^{\circ}\text{C}$). If one of the limits exceeds, TC305/TC303 shows the respective text **CJ.LO** or **CJ.HI** as long as the measurement is out of range.

In external CJ-mode there is a message **CJ.OPEN**. It means that the Pt100 probe at the reference junction is open.

For checking the set or measured reference junction temperature, see part C of this manual. Checking the reference temperature may be helpful when you want to assure error free measurement.

2.4 Millivolt generation

Use millivolt generation to calibrate instruments with millivolt input. You can use it also to simulate special thermocouples not defined in TC305/TC303. If you simulate a thermocouple in millivolt mode, you must convert from temperature to millivolts manually.

The following operations configure TC305/TC303 for millivolt generation:

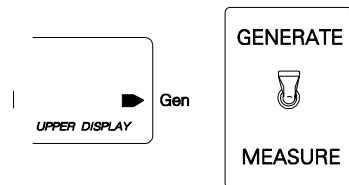

- a) The **MEASURE/GENERATE**-switch to the position **GENERATE**. An arrow on the upper display points to **Gen**.

If you just switched to the **GENERATE** position, the upper display shows the configuration state prompt **OUT.CNF**. If not, press the **ESC[OUT]** key to go to the configuration state.

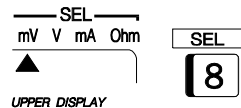

- b) Press the **SEL[8]** key repeatedly until an arrow on the upper display points to **mV**.

If you entered millivolt generation using the key **SEL[8]**, the default **CJ**-mode is none (no arrows shown in the **CJ**-section of the upper display). Use the other choices in thermocouple simulation only.



When the configuration is done, exit the configuration state by pressing the **OUT[ESC]** key. See Chapter 2.2, how to enter **mV**-values to be generated.

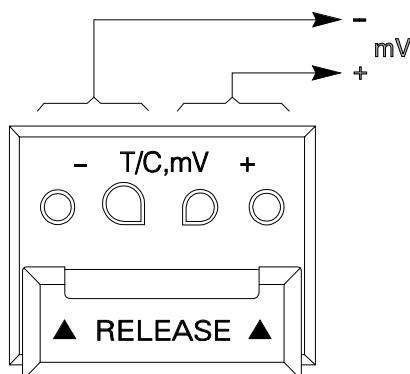

Connect the millivolt signal from the thermocouple connector block of TC305/TC303 to the instrument under test. The polarity of the generated signal is as marked on the connector block.

Note:

If you generate millivolts to simulate a thermocouple, select the proper CJ-mode. The thermocouple type arrow in millivolt generation is shown only in CJ-modes other than 'none'. When the sensor type is shown, select the right type to enable accurate reference temperature compensation.

Warning:

If you short circuit the millivolt output, TC305/TC303 tries to maintain the voltage by increasing the output current. If you then open the output again, the voltage is first too high, but returns quickly to the correct level. If this voltage peak could damage the components of the circuit, make sure that the circuit can not be shorted or protect the circuit against overvoltage. For the same reason, always enter 0mV output before connecting the circuit.

2.5 RTD- and resistance simulation

TC305/TC303 mimics the RTD or resistor to be measured by the instrument under test. The instrument under test generates the current for the resistance measurement. TC305/TC303 controls the voltage across its terminals so that the resistance (voltage to current ratio) corresponds to the simulated temperature or resistance.

The following operations configure TC305/TC303 for RTD- or resistance simulation:

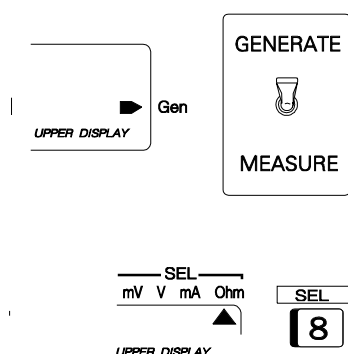

- a) The **MEASURE/GENERATE**-switch to the position **GENERATE**. An arrow on the upper display points to **Gen**.

If you just switched to the **GENERATE** position, the upper display shows the configuration state prompt **OUT.CNF**. If not, press the **ESC[OUT]** key to go to the configuration state.

- b) Press the key **SEL[8]** repeatedly until an arrow on the upper display points to **Ohm**.

Carry out the items c) and d) only in RTD-simulation:

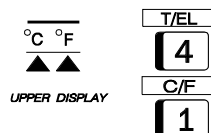

- c) Press the key **T/EL[4]**. The arrow at **Ohm** disappears and new arrows point to **Pt100** and temperature unit on the upper display.

Pt100 is the only RTD-type implemented in TC305/TC303 as standard. Other types can be added as option to the special sensor types S1, S2 and S3. If additional types have been added, use the key **SENSOR** to select the required type.

- d) If the temperature unit is not the required one, press the **°C/°F[1]** key to change the temperature unit.



When the configuration is done, exit the configuration state by pressing the **OUT[ESC]** key. See Chapter 2.2, how to enter simulation values.

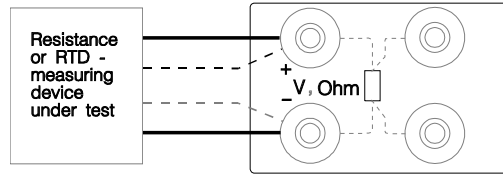

Use the two leftmost TC305/TC303 OHM/VOLT terminals for RTD-simulation. Don't connect anything to the other OHM/VOLT terminals. The proper wiring method (2-wire/3-wire/4-wire) depends on the instrument under test.

Note:

In resistance simulation the instrument under test supplies the measurement current. Accurate operation of the simulation electronics requires that the current does not vary rapidly. The simulation result is not accurate, if the instrument under test uses AC-current. If the instrument under test uses pulsed measurement current, it should wait a few milliseconds before starting the measurement after setting the current.

2.6 Milliampere generation

Use milliampere generation to calibrate instruments with milliampere input. The following operations configure TC305/TC303 for milliampere generation:

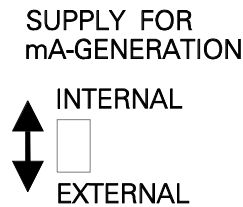

- a) Check the position of the switch **SUPPLY FOR mA GENERATION**. If there is no external supply in the loop, use the position **INTERNAL**, otherwise **EXTERNAL**. Whenever you select the mA generation or change the position of the supply switch, TC305/TC303 shows the supply switch position on the upper display. It flashes one of the messages **INT.SRC** or **EXT.SRC**.

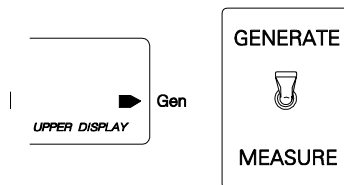

- b) The **MEASURE/GENERATE**-switch to the position **GENERATE**. An arrow on the upper display points to **Gen**.

If you just switched to the **GENERATE** position, the upper display shows the configuration state prompt **OUT.CNF**. If not, press the **ESC[OUT]** key to go to the configuration state.

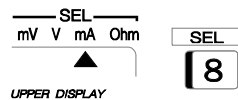

- c) Press the **SEL[8]** key repeatedly until an arrow on the upper display points to **mA**.



When the configuration is done, exit the configuration state by pressing the key **OUT[ESC]**. See Chapter 2.2, how to enter mA-values to be generated.

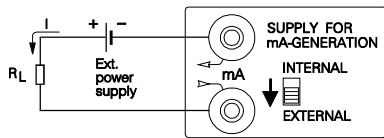

Connect the milliamperere signal from the TC305/TC303 A-section milliamperere terminals to the instrument under test. The polarity of the generated signal is as marked with arrows on the connection panel. If there is an external power supply in the loop, the switch for mA-generation supply should be set to position **EXTERNAL**.

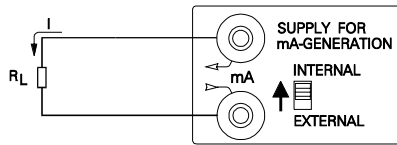

If there is no external power supply in the loop, the switch for mA-generation supply should be set to position **INTERNAL**.

Warning:

If you open the mA generation loop, TC305/TC303 tries to maintain the current by increasing the output voltage. If you then close the loop again, the current is first too high, but returns quickly to the correct level. If this current peak could damage the components of the loop, make sure that the loop will not open or protect it against overcurrent. For the same reason, always enter 0mA output before connecting the loop.

2.7 Voltage generation

Use voltage generation to calibrate instruments with voltage input. The following operations configure TC305/TC303 for voltage generation:

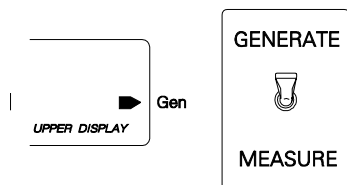

- a) The **MEASURE/GENERATE**-switch to the position **GENERATE**. An arrow on the upper display points to **Gen**.

If you just switched to the **GENERATE** position, the upper display shows the configuration state prompt **OUT.CNF**. If not, press the **ESC[OUT]** key to go to the configuration state.



- b) Press the **SEL[8]**-key repeatedly until an arrow in the upper display points to **V**.



When the configuration is done, exit the configuration state by pressing the **OUT[ESC]** key. See Chapter 2.2, how to enter voltages to be generated.

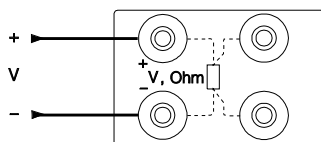

Connect the voltage signal from the TC305/TC303 A-section voltage terminals to the instrument under test. The polarity of the generated signal is as marked on the connection panel.

Warning:

If you short circuit the voltage output, TC305/TC303 tries to maintain the voltage by increasing the output current. If you then open the output again, the voltage is first too high, but returns quickly to the correct level. If this voltage peak could damage the components of the circuit, make sure that the circuit can not be shorted or protect the circuit against overvoltage. For the same reason, always enter 0V output before connecting the circuit.

3 MEASUREMENTS IN B-SECTION

3.1 General

The A-section circuits are electrically isolated from the B-section. This makes it possible e.g. to generate the input of an electrical converter in the A-section while simultaneously measuring the converter output in the B-section.

Notes:

You can measure millivolts, volts and milliamps also in the A-section, but not simultaneously with the generation/simulation functions.

The B-section is in connection to the calibrator chassis through the black terminal (-).

3.2 Milliampere measurement

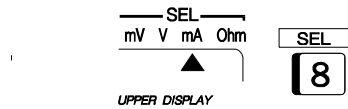

To select milliampere measurement in the B-section, repeatedly press the key **SEL[9]** until an arrow on the lower display points to **mA**.

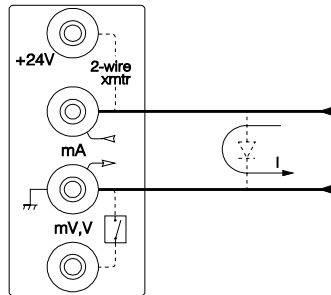

The impedance of the milliampere input is about 6 ohms. It is low enough to enable current measurement parallel to a test diode in a 20mA circuit. Make connections for the measurement. Check that the current direction corresponds to the arrows on the connection panel. The lower display shows now the measured current in milliamps.

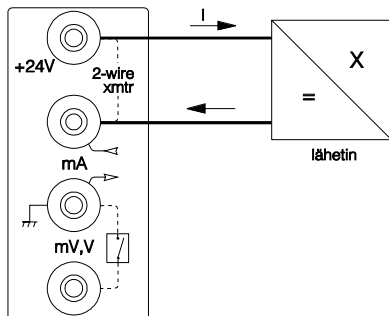

If the 24V option is installed to the calibrator, it can provide the 2-wire transmitter supply voltage while simultaneously measuring the transmitter output current. The following drawing shows the required wiring.

3.3 Millivolt and volt measurement

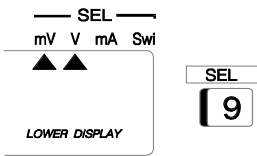

To select voltage measurement in B-section, repeatedly press the **SEL[9]** key until an arrow on the lower display points to **V** or **mV**.

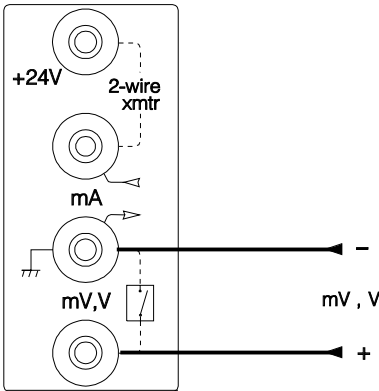

Make connections for the measurement. Check that the voltage polarity is as marked on the connection panel.

The lower display shows now the measured volts or millivolts.

3.4 Testing switch contact operation

You can use the B-section voltage measurement terminals also to detect the state of a switch contact (e.g. thermostat or electrical limit switch).

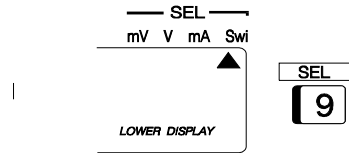

To select the switch state detection, repeatedly press the **SEL[9]** key until the arrow on the lower display points to **Swi**.

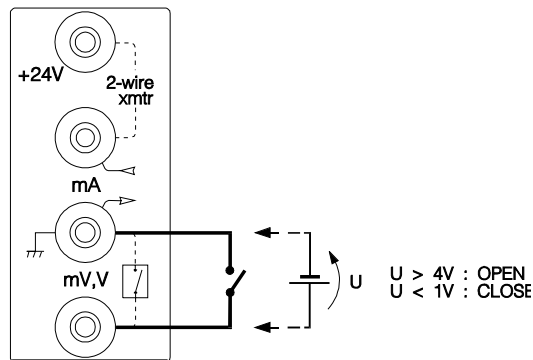

The contact should be free of external potential. If this is not possible, use DC-voltage within the range -10V to +30V. TC305/TC303 shows voltages above +4V as open contact and voltages below +1V as closed contact.

TC305/TC303 now checks the state of the switch contact. Letter 'c' on the lower display shows that the contact is closed. Open state is shown with letter 'o' respectively. Whenever the state of the switch contact changes, the letter changes respectively.

4 OTHER BASIC FUNCTIONS

4.1 Percentage and error displays

It is often convenient to operate with percentage values of instrument input and output signals. In TC305/TC303 you can operate both sections of the calibrator in percentage mode or in engineering units. When adjusting the calibration of e.g. a temperature transmitter, the percentage error mode in the B-section is very practical. Use of percentage displays presumes, however, that you set the range limits according to the input and output ranges of the instrument under test.

Example:

The instrument under test is a temperature transmitter, measurement range is 0 to 500°C and output signal is 4 to 20mA.

Turn the MEASURE/GENERATE switch to the position GENERATE. The upper display should show the message

OUT.CNF

Select the electrical and temperature units as explained in the previous chapters and exit the configuration state by pressing the **ESC[OUT]** key.

Enter the temperature simulation value, say

250 ENT

Lets assume that the transmitter output is slightly high and the displays are:

250.0 °C

12.160 mA

To be able to use the percentage modes, you must enter the input and output range limits. The orange keys **0%[.]** and **100%[2]** are for the A-section range (0 to 500°C) and the blue keys **0%[+/-]** and **100%[3]** are for the B-section range (4 to 20mA).

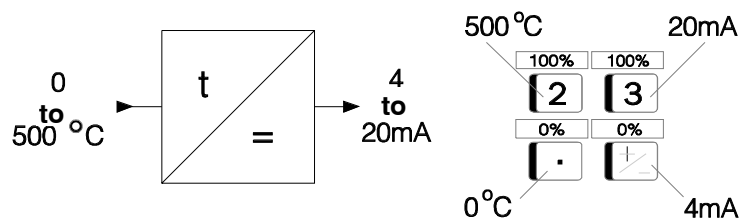

Press first the key **ESC[OUT]** to get the **OUT.CNF** message. Then check the range limits. Lets assume that you get the following displays for each key:

0%
■

0 °C
ZERO

100%
2

80 °C
F.SCALE

0%
+/-

ZERO
4 mA

100%
3

F.SCALE
20 mA

If all values were right, you should press **ESC[OUT]** to exit. In this case the temperature full scale value was wrong and must be corrected by pressing the respective key twice:

100%
2

800 °C
F.SCALE

100%
2

? °C
F.SCALE

5 0 0 ENT

TC305/TC303 returns automatically to the basic measure/generate function showing again

250.0 °C
12.160 mA

The upper display mode key MODE[5] is used to toggle between normal mode and per cent of range. The lower display (key □MODE[6]) has also percentage error mode. In GENERATE function the mode keys are active only when the message OUT.CNF is shown on the upper display. Use the key □ESC[OUT] to toggle between normal and output configuration state.

Press the keys

□ESC[OUT] □MODE[6] □ESC[OUT]

to switch the B-section to percentage mode. The transmitter output current should now be converted to per cent of range:

250.0 °C

50.10 %

To make the transmitter calibration job even easier, select the percentage error mode:

□ESC[OUT] □MODE[6] □ESC[OUT]

Now the display readings should be

250.0 °C

0.10 E%

TC305/TC303 calculates now the error of the transmitter output. The lower display shows the output error in per cent of the range.

You can switch also the A-section to percentage display mode by pressing the keys

□ESC[OUT] □MODE[5] □ESC[OUT]

Now the display readings should be

50.00 %

0.10 E%

When the upper display is in percentage mode, the simulation values must be entered in per cent of range, too. Pressing any of the keys □SEL[8], □SEL[9] or □T/EL resets both mode-settings to normal mode.

4.2 Use of the Working Memory

You can store the displayed measurement and generation values in a memory area called Working Memory. Use the key **□STO** to store readings and the key **□RCL** to recall previously stored readings.

In the Working Memory there is space for 21 pairs of readings. The memories are numbered 0 to 9, +/- and .9 to .0.

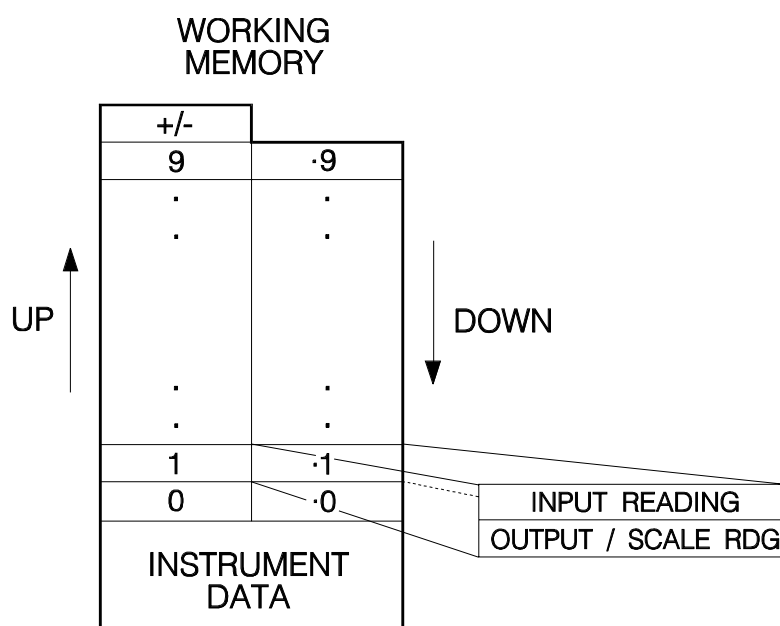

To store the displayed values to the memory number 5, press the keys

□STO □5

Respectively, to store to the memory number .7, press

□STO □. □7

Recall from memory +/- by pressing

□RCL □+/-

While displaying the recalled values, all arrows are shown but only the active arrows flash. The steady arrows distinguish the recalled display from normal active display. TC305/TC303 doesn't store the mode-settings of the displays. It shows the recalled readings in the modes that are active at the moment. Percentage readings are however meaningful only if range limit settings are same as at the time of storing.

When TC305/TC303 shows recalled memory values, you can anytime recall new values. Pressing **□ESC[OUT]** causes return to basic measure/generate function.

All stored pairs of readings have common display units. If the units of the new readings differ from the units of the already stored readings, storing is denied and TC305/TC303 flashes the message

**CONFIG
DIFFER**

If you retry, TC305/TC303 stores the displayed readings but it clears all other readings from the Working Memory.

5 SOFTWARE OPTIONS

The following software options are available to TC305/TC303 calibrator:

TCAL305 expansion

This option makes TC305/TC303 Temperature Calibrator part of the Beamex QCAL Quality Calibration System. It receives instrument data from the CALDB3 database in the computer, enables calibration of the instruments with the Quick Store function and finally sends the calibration results back to the database in the computer.

Switch calibration

This option enables calibration of electrical limit switches and thermostats.

Additional sensors

In TC305/TC303, Pt100 and eight thermocouple types are defined as standard. If this is not enough, additional sensors can be defined as options.

Sensor modification

This option enables modification of any of the defined standard or additional sensors. For instance, you can modify Pt100 to Pt200 or adapt the Pt100 definition to the changed R_0 value of the used Pt100 sensor.

**CONFIGURATION
AND
FUNCTION MENUS**

1 GENERAL

You can make the most common configurations by using dedicated keys. These configurations, like selecting input/output terminals, units and sensor type as well as setting the limits of instrument input and output ranges, are explained in part B of this manual. Also some basic functions, like storing to and recalling from the Working Memory, have dedicated keys and their use is explained in part B of this manual.

Some seldom needed advanced configurations and functions are collected in the configuration and function menus. The use of the menus is made as simple as possible. You can start one of the menus in the basic measure/generate operation by pressing the key \square CONF [CL] or \square FUNC [ENT].

Some entries of the menus have also second and even third level submenus. The function of the submenus is similar to the main menus. At any level in a menu, you can escape to the basic measure/generate operation by pressing the key ESC.

At any level of TC305/TC303 menus, the upper display shows the menu title. Blinking arrows on both sides of the lower display show that you can use the up/down keys to scan through the menu.

menu title

< entry >

When you find the right entry from a menu, press ENT to select it.

Some of the menu entries are partly or entirely optional and are included only if the respective software option is installed:

- * The Configuration menu entry DELAY exists only if **TCAL305** expansion or Switch calibration option is installed.
- * The Configuration menu entry F.TYPE as well as the Function menu entries SAVE, LOAD and CLEAR exist only if **TCAL305** expansion is installed.
- * The Function menu entry SWITCH exists only if Switch calibration option is installed.
- * In special sensor definition (CONF/OTHERS/123), the modification FACTOR can be entered only if the Sensor modification option is installed.

2 CONFIGURATION MENU

Enter the menu by pressing the key

CONF

You will get the first entry of the menu:

CONF

<SQRT>

This stands for "square rooting calculation". You can scan through the main menu by pressing the up or down arrow key. Select one of the entries by pressing the key ENT or escape to the basic measure/generate operation by pressing the key ESC.

The entries and quick select keys in the CONF main menu are:

<u>Entry</u>	<u>Description</u>	<u>Quick key</u>
SQRT	Square rooting error calculation (only with f.types FREE, EEC and EIR)	4
F.TYPE	Instrument function type selection (requires TCAL305 option)	CL
USER0	Recalling user configuration 0	0
USER1	Recalling user configuration 1	1
USER2	Recalling user configuration 2	2
3. PNTS	Auto definition of 3 cal. points	3
5. PNTS	Auto definition of 5 cal. points	5
7. PNTS	Auto definition of 7 cal. points	7
11.PNTS	Auto definition of 11 cal. points	+/-
CAL.PTS	View/manual def. of cal. points	.
DELAY	Defining set point delay (requires TCAL305 or SWITCH option)	6
DATE	Setting/monitoring date	8
TIME	Setting/monitoring time	9
OTHERS	Other configurations	STO

The quick selections always start with the **CONF** key. You will see the first entry of the menu. Pressing the actual quick key directs you to the desired entry and selects it. You may also, if you want, scan through the menu and still use the quick key for selection.

2.1 Square rooting calculation

Square rooting converters, indicators and recorders are sometimes used in flow measurement circuits. In rooting instruments, the output or indication is proportional to the square root of the input signal. While testing these instruments, switch on the square rooting error calculation to enable correct display in percentage error display mode.

In order to toggle the square rooting calculation on or off, select the configuration menu entry

CONF

<SQRT>

(quick select CONF 4)

An arrow pointing the square root sign on the right side of the upper display shows that square rooting is on.

You can toggle the square rooting calculation only with instrument function types FREE, EEC and EIR. When you select a new instrument function type, TC305/TC303 switches the square rooting off.

2.2 Instrument function type

Instrument function type selection is included only if TCAL305 expansion is installed. TC305/TC303 recognizes the following instrument function types:

0	FREE	undefined type (default)
1	TE	temperature sensor
2	TT	temperature transmitter
3	TIR	temperature indicator or recorder
4	TSNC	temperature switch (thermostat), contact normally closed
5	TSNO	temperature switch (thermostat), contact normally open
6	EEC	electrical converter
7	EIR	electrical indicator or recorder
8	ESNC	electrical limit switch, contact normally closed
9	ESNO	electrical limit switch, contact normally open
10	TRC	own temperature range of the calibrator
11	ERC	own electrical range of the calibrator.

The types TSxx and ESxx are included in the list only if switch calibration option is installed. The default instrument function type is FREE. It is a type that as far as possible adapts to the user selections SEL, T/EL and MEASURE/GENERATE. Before using the Quick Store function, select one of the types 1 to 11. You cannot use the type FREE in the Quick Store function.

Select the instrument function type from the configuration menu entry

CONF

<F.TYPE>

(quick select CONF CL)

TC305/TC303 displays the valid instrument function type at the moment, e.g.

F.TYPE

<0 FREE>

Use the up/down arrow keys to scan the list of instrument function types. When you find the required type, press ENT to select it. With types other than FREE, TC305/TC303 - if necessary - automatically changes the SEL[9] setting (switch / not switch). It also selects T/EL according to the instrument function type. In case you don't want to change the instrument function type, press ESC to escape without changing anything.

TC305/TC303 software can use several methods (input methods) to calibrate a certain type of instrument. If you select a type (other than FREE), a new menu enables the input method selection, e.g.

METHOD

<GEN>

Scan up/down to find the right choice and select with ENT. If you press ESC, both the function type and the input method remain unchanged.

With instrument function types TSxx and ESxx, TC305/TC303 still prompts for the number of required test repetitions in the Quick Store function:

TESTS

10

Enter the number (1 to 10) or accept the previous setting by pressing ENT only.

Chapter 6 in part D explains the selection of the right method for each case. Selecting a new instrument function type or input method resets both displays to normal mode (engineering units).

2.3 User configurations

You can save four different configurations in the TC305/TC303 memory. These configurations include:

- * 0% and 100% settings
- * SEL-key settings
- * display MODE settings
- * default sensor type for each input terminals
- * T/EL-selection
- * Temperature unit
- * CJ-mode
- * manual CJ-temperature
- * time settings for STEP and RAMP
- * calibration points
- * set point delay
- * default special measurement
- * instrument function type
- * square rooting
- * ITS-90 temperature scale
- * including Kelvin in the temperature unit list
- * DATE format
- * Serial interface settings (can be set via the serial interface only).

If use of default configuration is enabled, TC305/TC303 recalls one of the configurations (default configuration) when you switch it on.

You can recall any of the three other configurations by selecting the respective entry from the CONF menu. The menu entries are:

USER0	(quick select <input type="checkbox"/> CONF <input type="checkbox"/> 0)
USER1	(quick select <input type="checkbox"/> CONF <input type="checkbox"/> 1)
USER2	(quick select <input type="checkbox"/> CONF <input type="checkbox"/> 2)

If TCAL305 is installed and data in the Working Memory has not yet been saved to the Data Memory, the message

**NOT
SAVED**

flashes when trying to recall user or default configuration. In this case TC305/TC303 denies the recalling. Before retrying, you can save the Working Memory contents to a memory area in the Data Memory if you wish. Whether you save or not, the next trial overwrites the Working Memory.

See Chapter 2.7, how to save the default and user configurations.

2.4 Calibration points

There are four standard settings for calibration points. In order to select one of the settings, use one of the following configuration menu entries:

CONF <3. PNTS>	(quick select <input type="checkbox"/> CONF <input type="checkbox"/> 3) points: 0%, 50%, 100%
CONF <5. PNTS>	(quick select <input type="checkbox"/> CONF <input type="checkbox"/> 5) points: 0%, 25%, 50%, 75%, 100%
CONF <7. PNTS>	(quick select <input type="checkbox"/> CONF <input type="checkbox"/> 7) points: 0%, 10%, 25%, 50%, 75%, 90%, 100%
CONF <11.PNTS>	(quick select <input type="checkbox"/> CONF <input type="checkbox"/> +/-) points: 0%, 10%, 20%, ..., 90%, 100%

If none of these standard settings is suitable, select manual calibration point setting from configuration menu entry

CONF <CAL.PTS>	(quick select <input type="checkbox"/> CONF <input type="checkbox"/> .)
---------------------------------------	---

The calibration points are normally instrument input values. If the instrument under test is indicator or recorder, they are, however, readings of the indicator/recorder. Depending on the respective MODE setting, enter the values either as percentage values or in engineering units. TC305/TC303 stores the calibration points always as percentage values. Check always the range limits before entering the calibration points in engineering units.

TC305/TC303 doesn't accept a value outside the range +/-200%. The first calibration point should be the smallest value and the last point the biggest value. While testing the calibration, you can, however, choose whether you want to test upwards only or both up and down. In up/down calibration you will go from the first point to the last point and down back to the first point. This enables the testing of the instrument hysteresis.

If some points are already set, use the up/down keys to scan through the points. If you want to add a new point to the end or alter an existing point, go to the point, key in the new value and press ENT. TC305/TC303 automatically advances to the next point.

If you want to insert an extra point, go to the point next to the one to be inserted and press ENT. This makes space for the new point and you can enter it's value.

To remove a point, go to that point and press the key CL and then ENT. If the removed point was not the last point, the remaining points will shift leaving the empty points at the end.

After entering the last point, you will come back to the beginning. Press ESC to escape to the basic measure/generate operation.

2.5 Set point delay

In automatic calibration TC305/TC303 lets the readings to settle a certain time before storing. While testing a switch, a certain settling time is needed to allow the switch to operate, too. If either TCAL305 expansion or Switch calibration option is installed, the set point delay setting is included in the configuration menu:

CONF
<DELAY> (quick select CONF 6)

TC305/TC303 prompts

DEL.SEC

on the upper display and shows the current delay setting on the lower display. If the time is not suitable, alter it by keying in the new value (0 to 199.99 seconds) and pressing ENT. Pressing ESC escapes without altering the previous setting.

2.6 Date and time

TC305/TC303 internal calendar assures that you calibrate TC305/TC303 in time. Setting of the calibration period is explained in Chapter 2.7. The calendar also automatically enters the calibration date into the instrument calibration data, when you use the Quick Store function of TCAL305 expansion. To assure the right changing of the day, also local time is required.

Select the configuration menu entry

CONF
<TIME> (quick select CONF 9)

for setting or watching the time. Use respectively the entry

CONF
<DATE> (quick select CONF 8)

for setting or watching the date.

TC305/TC303 requests the new date or time on the upper display. The lower display shows the active date or time. To alter the time or date, key in the new value and press ENT. After pressing the first number of the time or date, TC305/TC303 shows the required format on the upper display. The format for the time is always 'hh.mm.ss'. The date format is 'dd.mm.yy', 'mm.dd.yy' or 'yy.mm.dd'. See Chapter 2.7, how to change the date format.

After you have entered a new value, TC305/TC303 continues by showing the new time or date. Press ESC to escape from the function.

2.7 Others

The configuration entry

CONF

<OTHERS> (quick select CONF STO)

is a collection of several seldom needed configurations. When you select the entry, TC305/TC303 requests for the code of the required configuration:

C.CODE?

Key in the code number of the required configuration and press ENT. You should be very careful, not to enter a wrong code. Use only the codes in the following list. Some codes, not shown here, are reserved for Beamex use only. Random use of codes not mentioned here may seriously damage the device operation.

Code Function

0	Save USER0 configuration
1	Save USER1 configuration
2	Save USER2 configuration
11	Set/check the use of Kelvin (yes/no)
80	Show dates of latest calibrations
81	Show dates for next calibrations
88	Select date format
90	Set/check the temperature scale (ITS90/IPTS68)
100	Show software version numbers
101	Hardware serial numbers
123	Define special sensor
210	Save default configuration
211	Recall factory settings
212	Set/check the use of default settings (yes/no)

2.7.1 User configurations and default configurations

To make the use of the calibrator easy in spite of the many functions, saving and recalling different configurations is made possible. Before saving a TC305/TC303 configuration, carefully check all the selections and settings listed in Chapter 2.3. You can reserve the three user configurations for different users or different works. Recall any of these configurations whenever you need it. TC305/TC303 recalls (if allowed) the default configuration automatically, when you switch it on. Altering the configurations is very easy. It is, however, best to make them originally as meaningful as possible. The factory setting for all configurations is the following:

* <input type="checkbox"/> SEL[8]: mV			
* A-section limits	<u> </u>	<u>0 %[.]</u>	<u>100 %[2]</u>
	mV	0	100 mV
	V	0	10 V
	mA	4	20 mA
	ohm	0	100 ohm
	temp.	0	100 °C
	<u>switch</u>	<u>act</u>	<u>deact</u>
		0	0

* <input type="checkbox"/> SEL[9]: mA			
* B-section limits	<u> </u>	<u>0 %[+/-]</u>	<u>100 %[3]</u>
	mV	0	100 mV
	V	0	10 V
	mA	4	20 mA
	<u>Swi</u>	<u>scan lo</u>	<u>scan hi</u>
		0	0

- * MODE[5] and MODE[6]: engineering units
- * Default sensor: K / Pt100
- * T/EL[4]: temperature
- * CJ[0]: int
- * Manual CJ-temperature: 0°C
- * STEP-setting: STP.SEC = 5 s
- * RAMP-settings: LO.SEC = 5 s
UP.SEC = 5 s
HI.SEC = 5 s
DN.SEC = 5 s
- * Special measurement default = battery measurement
- * Calibration points: 5-point calibration
- * Set point delay: 4 s
- * Instrument function type: FREE
- * Input method: not applicable with FREE
- * Square rooting: off
- * ITS90 correction: on
- * Including Kelvin in the temperature unit list: no
- * Temperature unit: °C
- * DATE format: DD.MM.YY
- * Serial interface settings as defined in Service Manual.

Use the codes 0, 1 and 2 to save current configuration to one of the user configurations. Use code 210 to save new default settings. Code 211 is mainly for manufacturer use. It recalls the factory settings.

Some users may want to prevent the use of default settings. You can toggle the use of default settings on/off with the code 212. If you prevent the default settings, all settings will stay at power on just as they were when switching the device off. This may be good, if the user is always the same person. If there are several users for the same calibrator, we recommend the use of default settings.

If TC305/TC303, for some reason, finds error in its memory, it sets the factory settings to the default configuration and to all user configurations.

2.7.2 Temperature scale

The international Temperature Scale ITS90 was defined January 1. 1990, but the respective corrections to the international temperature sensor standards IEC751 (Industrial platinum resistance thermometer sensors) and IEC584-1 (Thermocouples) were published as late as September 1995. These new standards are now implemented in TC305/TC303).

After entering the code 90, TC305/TC303 shows the currently selected temperature scale, e.g.

T.SCALE
<ITS.90>

Use the up/down keys to toggle between the (ITS90/IPTS68) scales. Select the displayed choice by pressing ENT. Press ESC to escape without change. Selection of the ITS90 scale is recommended.

Function, while ITS90 is selected:

- With the standard sensors B, E, J, K, N, R, S, T and Pt100, TC305/TC303 follows directly the new IEC sensor standards defined according to the ITS90 temperature scale.
- If there are some special sensors defined according to the ITS90 temperature scale, TC305/TC303 follows directly the given reference table of such special sensor.
- If there are some special sensors defined according to the IPTS-68 temperature scale, the measured temperature readings are converted to ITS90. Respectively the entered temperature readings in sensor simulation are assumed to be ITS90 temperatures and they are converted to IPTS-68 before converting to thermovoltage or resistance. Conversions between the two temperature scales are made according to the official conversion tables published by BIPM.

Function, while IPTS-68 is selected:

- If the sensor is one of the TC305/TC303 standard sensors or if the selected special sensor is defined according to the IPTS-68 temperature scale, TC305/TC303 directly follows the given reference table of such special sensor.
- If the selected special sensor is defined according to the ITS90 temperature scale, selecting IPTS-68 has no effect.

2.7.3 TC305/TC303 recalibration dates

Code 80 shows the latest calibration dates of TC305/TC303. The date on the upper display tells the calibration date of the A-section measurements and generations/simulations. The lower date shows the latest calibration of the B-section measurements. Press \square ESC to escape to the basic measure/generate operation.

Code 81 shows the recommended next calibration dates. The date on the upper display tells the recommended next calibration date of the A-section measurements and generations/simulations. The lower date is the respective date for the B-section measurements. Press \square ESC to escape to the basic measure/generate operation.

2.7.4 Use of Kelvin

Kelvin (K) is the basic temperature unit in the SI-system. It is not often used in industrial measurements, but you may, anyhow, want to enter and display temperatures in Kelvin. If you enable Kelvins, you can select them using the key $^{\circ}\text{C}/^{\circ}\text{F}$. After Fahrenheit there is a third state when both $^{\circ}\text{C}$ and $^{\circ}\text{F}$ arrows are visible. In this state TC305/TC303 displays temperature in Kelvin and expects you to enter temperatures in Kelvin. Select code 11 in the CONF OTHERS entry to enable or disable the use of Kelvin.

2.7.5 Date format

To ease the understanding of dates displayed by TC305/TC303, you can choose of three different formats. The three formats are:

DD.MM.YY (day month year)

MM.DD.YY (month day year)

YY.MM.DD (year month day)

After entering the code 88, TC305/TC303 shows the current format, e.g.

DATE F

<DD.MM.YY>

Use the up/down keys to select the preferred format and press ENT. Press ESC to escape without change.

2.7.6 Software version numbers

When communicating with the manufacturer, it is often useful to check the calibrator software version numbers. TC305/TC303 contains two microprocessors, one for the B-section and for communication with the user and with the computer. The other microprocessor controls the operation of the A-section. Enter the code 100 to get the version number display. The upper display shows the version of the A-section microprocessor software. The version number on the lower display is the one of the B-section microprocessor. Press ESC to escape this display.

2.7.7 Serial numbers

While using the TCAL305 expansion, the computer should be able to check the calibrator serial number. For this purpose, the serial number is stored in the analog part EEPROM memory. If the analog part has been replaced in service, the calibrator serial number should have been re-entered, too. You can check the serial numbers by entering the code 101. The upper display shows the calibrator serial number. The number on the lower display is the serial number of the analog part.

2.7.8 Special sensor definition

The standard sensors recognized by TC305/TC303 include all the sensors defined in IEC standards 584-1 and 751. In addition to these, some other sensors can be defined as option. These additional sensors may be thermocouples, RTD:s or even sensors with volt or mA output.

The basic sensor types of TC305/TC303 are numbered as follows:

<u>B.S.No</u>	<u>Type</u>	<u>Standard</u>
0	B	IEC 584-1 Second edition, 1995-09
1	E	IEC 584-1 Second edition, 1995-09
2	J	IEC 584-1 Second edition, 1995-09
3	K	IEC 584-1 Second edition, 1995-09
4	N	IEC 584-1 Second edition, 1995-09
5	R	IEC 584-1 Second edition, 1995-09
6	S	IEC 584-1 Second edition, 1995-09
7	T	IEC 584-1 Second edition, 1995-09
8	Pt100	IEC 751 Amendment 2, 1995-07

Numbers greater than eight are reserved for the possible additional basic sensor types. You can fix additional sensors to the special sensor places S1, S2 and S3. Each additional sensor has a name of max 7 characters. Six first characters of the name are shown for about two seconds, when you select that sensor. To specify a special sensor:

- * Use the SEL[8] key to select the input/output connection (mV, V, mA) to be used for this special sensor.
 - * Select the entry CONF OTHERS and enter the code 123.
 - * To the prompt
S.S.NO?,
enter the number of the special sensor (1, 2 or 3). Note that same special sensor number can be used for an RTD and for a thermocouple. Trying to define a second thermocouple or RTD to the same number, however, deletes the earlier definition.
 - * Next TC305/TC303 prompts for the basic sensor number you want to fix to this special sensor place:
B.S.NO?
Enter the number of one of the installed additional sensors. Definition of any of the standard sensors 0 to 8 is allowed, too. If you enter a sensor number that is not available, TC305/TC303 gives the message
**UNDEF.
SENSOR**
In this case TC305/TC303 doesn't select a new sensor, but it deletes the possible previous definition of this special sensor. You can use this to deselect a special sensor definition.
- If special sensors are defined for the active terminals (mV, V, mA, ohm), they can be selected just as standard sensors.

Note that definition of special sensors S1 to S3 is not included in the user configurations or in the default configuration. Recalling factory settings does not affect special sensor definition.

Sensor modification option

An optional sensor modification is available for TC305/TC303. It enables creation of new sensor types by modifying the existing ones. Modification of a standard or additional sensor is carried out by giving a modifying factor.

Example 1:

Using a factor 2.0000 for the Pt100 sensor gives a new sensor type equal to Pt200. Resistance at 0°C is 200 ohms and at any temperature the resistance is double compared to Pt100.

Example 2:

You have found out, that the actual resistance of a Pt100 sensor at 0°C is 100.05ohms. You can create a new type for this particular sensor. Use the type Pt100 with the factor 1.0005.

Example 3:

The output of your calibrated K-type sensor at 700°C corresponds 701°C according to the reference table. You can create a new sensor type that mimics this sensor at least around 700°C. Use the type K and a factor $701/700 = 1.00143$.

If the Sensor modification option is installed, the special sensor definition starts as usually, but continues with the prompt

FACTOR

Enter the modification factor, calculated as explained in the previous examples. If you just want to fix an additional sensor to this special sensor place as it is, enter the factor 1.

If the entered factor was other than 1, TC305/TC303 prompts

TYPE

Enter a name of max. eight characters. See Chapter 7 in part D, how to key in alphabetic characters. If this modified sensor is defined in the computer database, the same type name should be used.

If TC305/TC303, for some reason, finds error in its RAM memory, it takes the default factory configuration and deletes all special sensor definitions. You do not lose the possible additional sensors. You must only redefine the special sensor place, factor and type name for each additional sensor.

3 FUNCTION MENU

Enter the menu by pressing the key

□FUNC

You will get the first entry of the menu:

FUNC

<SPEC.ME>

This stands for "special measurements". You can scan through the main menu by pressing the up or down arrow key. Select one of the entries by pressing the key

□ENT or escape to the basic measure/generate operation by pressing the key

□ESC. The entries and quick select keys in the FUNC main menu are:

<u>Entry</u>	<u>Description</u>	<u>Quick key</u>
SPEC.ME	Special measurements (submenu)	□+/-
RAMP	Ramp definition/generation	□7
STEP	Auto stepping definition/generation	□8
SWITCH	Switch test	□9
SAVE	Saving to the Data Memory	□STO
LOAD	Loading from the Data Memory	□RCL
CLEAR	Clearing memory (submenu)	□0

The quick selections always start with the □FUNC key. You will see the first entry of the menu. Pressing the actual quick key directs you to the desired entry and selects it. You may also, if you want, scan through the menu and still use the quick key for selection.

3.1 Special measurements

The special measurements include the measurement of

- * the thermocouple reference junction temperature (CJ temperature)
- * the state of the batteries
- * the rate of change of the both measurements
- * the minimum values of the both measurements
- * the maximum values of the both measurements.

In case of manual reference junction mode, you can enter new value to the reference junction temperature. You can also reset the rate, minimum and maximum measurements. In reset TC305/TC303 sets the minimum and maximum values to the current measurement values. Also the rate measurement forgets the history and starts from the beginning.

Select first the function menu entry

FUNC

<SPEC.ME> (quick select FUNC +/-)

TC305/TC303 selects automatically the measurement that you used last time. If you left special measurements in reset function, it selects the maximum measurement. First time after start-up TC305/TC303 uses the default selection.

You can use the up/down keys to scan the following choices of the special measurements submenu. Note that in Rate, Min and Max measurements both displays are needed to show the A- and B-section readings and no title for the menu entry is shown.

- a) **CJ-T**
 <value>
 This entry is included only when mV terminals are selected in A-section. This is the reference junction temperature. Depending on the reference junction mode, values are measured with the internal or with an external sensor or it is set manually. If the current reference junction mode is MANual, there is a question mark after CJ-T. In that case you can enter a new value to the reference temperature.
- b) **BATT**
 <value>
 The value is a rough approximation of the capacity left in the batteries. The capacity is shown in per cent of the nominal capacity. Measure it with the charger disconnected. Wait a few minutes after disconnecting the charger or after switching the calibrator on to get more reliable result.
- c) **rate value**
 <rate.value>
 The 1/min arrow on the lower display means that the readings on both displays show the change rate of the respective measurement readings. In milliampere measurement for instance, the reading 0.115 means that the current changes with the rate 0.115 mA/min. To increase the accuracy of the rate measurement, TC305/TC303 automatically uses longer calculation period with lower rates.
- d) **max.value**
 <max.value>
 The max arrow on the lower display means that the readings on the both displays show the maximum value measured after reset. TC305/TC303 resets the max. measurements automatically after power on. You can also reset manually by selecting the respective choice from this menu.
- e) **min.value**
 <min.value>
 The min arrow on the lower display means that the readings on the both displays show the minimum value measured after reset. TC305/TC303 resets the min. measurements automatically after power on. You can also reset manually by selecting the respective choice from this menu.
- f) **ENT =**
 <RESET>
 Use this choice to reset the calculation of min and max values. Resetting sets the minimum and maximum values equal with the current measurement readings. It has also some effect on the rate measurements. After reset the rate measurements start with the shortest calculation period independent on the rate.
- Press ENT to reset the measurements. TC305/TC303 automatically selects max measurement, after you have pressed the ENT key.

3.2 Ramp definition and generation

Select first the function menu entry

FUNC

<RAMP>

(quick select FUNC 7)

If the MEASURE/GENERATE switch is not in the position GENERATE, TC305/TC303 shows the message CONFIG ERROR. In this case, turn over to the position GENERATE or press ESC to escape from the function.

TC305/TC303 ramps between the 0%[.] and 100%[2] values. Ramping is continuous with the timing defined in the following submenu. You can use the up/down keys to scan the following choices of the ramp definition submenu:

a) **ENT =**

<RAMP>

Press ENT to escape the definition and start the ramp. Definition of all the times is not necessary, if the default or before defined timing is acceptable. Ramping continues until you press the key ESC.

b) **LO.SEC?**

<low time>

Enter the time (0 to 9999 seconds) to be spent at the 0% value.

c) **UP.SEC?**

<up time>

Enter the required rise time (0 to 9999 seconds) for the ramp. TC305/TC303 actually makes the ramp in small steps. The steps are as small as possible, slower ramps use smaller steps.

d) **HI.SEC?**

<high time>

Enter the time (0 to 9999 seconds) to be spent at the 100% value.

e) **DN.SEC?**

<down time>

Enter the required fall time (0 to 9999 seconds) for the ramp. TC305/TC303 actually makes the ramp in small steps. The step is as small as possible, slower ramps use smaller steps.

Press ESC at any place in the submenu to escape to the basic measure/generate operation. If you already started the ramp generation, pressing ESC stops the ramp and you will return to the basic measure/generate operation. If you set all times to zero, TC305/TC303 automatically corrects the 0% time (LO.SEC) to 1s. While ramping, TC305/TC303 shows the generated output on the upper display.

3.3 Auto stepping definition and generation

In the step function TC305/TC303 outputs a sequence of values. The values are the defined calibration points (see Chapter 2.4). Because the calibration points are stored as percentage values, check also the 0%[,] and 100%[2] settings.

Select first the function menu entry

FUNC

<STEP>

(quick select FUNC 8)

If the MEASURE/GENERATE switch is not in the position GENERATE, TC305/TC303 shows the message CONFIG ERROR. In this case, turn over to the position GENERATE or press ESC to escape from the function.

Next TC305/TC303 gives you the choice to select, whether you want to step up only or up and down. Use the up/down keys to select one of the two choices of the step definition submenu:

a)

STEP

<UP-DN>

If you choose UP-DN stepping, TC305/TC303 will start from the first calibration point and after the last point it will step back through the same points.

b)

STEP

<UP>

If you choose UP stepping, TC305/TC303 will start from the first calibration point and after the last point it will restart from the first point again.

Press ENT to select one of the choices. Next TC305/TC303 requests for the time to be spent at each point:

ST.SEC?

<step time>

If the default time is suitable, press ENT only. Otherwise, key in the required step time (1 to 9999 seconds) and press ENT.

Stepping starts, when you have pressed the ENT key. You can stop the stepping by pressing the key ESC. Pressing ESC at any stage during the step definition causes a jump to the basic measure/generate operation.

If no or only one calibration point is defined, stepping is not possible. In this case TC305/TC303 shows error message

NO CAL

POINTS

Instrument function type selection affects the step function. With types TIR and EIR the stored calibration points are in percentage of the indicated value. If square rooting is selected with type EIR, actual stepping values are squares of the stored calibration points.

3.4 Switch testing

Switch test is included in the Function menu only if the respective software option is installed. Carry out the necessary arrangements before selecting Switch test from the Function menu. Testing of both electrical limit switches and temperature limit switches (thermostats) is possible.

Use the **□SEL[9]** key to configure TC305/TC303 B-section for switch contact testing. Connect the switch contact to the B-section terminals (see Chapter 3.4 in part B of this manual).

If you test an electrical limit switch or a thermostat without sensor, turn the MEASURE/GENERATE switch to the position GENERATE. Configure TC305/TC303 A-section to generate/simulate the input of the instrument and wire the connection to the instrument. Test the connections by generating proper signals and observing the switch state on the lower display. Use the keys **□0%[+/-]** and **□100%[3]** to set so called scan limits. The **□0%[+/-]** value should be lower than the deactuating value and **□100%[3]** above the actuating value. These limits define the range of instrument input values in selected simulation/generation units. The values are used when TC305 performs an automatic scan to find the preliminary actuation and deactuation points of the switch.

If you want to test a thermostat with its sensor connected, turn the MEASURE/GENERATE switch to the position MEASURE. Connect a proper reference sensor and configure TC305/TC303 A-section for temperature measurement. Place the reference sensor together with the sensor of the thermostat to a proper calibration bath.

When all connections and configurations are ready, start the test by selecting the Function menu entry

FUNC

<SWITCH>

(quick select **□FUNC □9**)

The operation after this depends on the position of the MEASURE/GENERATE switch. If the TCAL305 is installed and readings in the Working Memory have not yet been saved to the Data Memory, the message NOT SAVED will flash. If you try another time, TC305/TC303 will, however, delete the old readings. If one or both of the scan limits are set out of the TC305/TC303 simulation/generation range, the message SCAN ERROR will be shown and you must press **□ESC** to exit.

A. GENERATE-position

TC305/TC303 carries out the test fully automatically. Before the actual test it runs a preliminary test. In the preliminary test TC305/TC303 will find out the limits for scanning the actuating and deactuating points in the final test. This speeds up the final test without sacrificing accuracy. TC305/TC303 shows the text

SCAN

during the preliminary test. The lower display counts the scanned points.

TC305/TC303 knows from the preliminary test the approximate ranges for the limit switch actuation and deactuation. In the final test TC305/TC303 scans the limit switch input through these ranges to detect the accurate actuation and deactuation points. While scanning for the actuation point of a normally open limit switch, the upper display shows the increasing input value, e.g.

234.35

o

The input value needed to close the switch contact (actuation point) freezes on the lower display while the upper display shows the scanning value for the deactuation point:

124.20

c241.10

When found, the deactuation point value freezes on the upper display:

o115.15

c241.10

B. MEASURE-position

Testing of temperature switches with integral sensor is controlled manually. To test such a switch, use a calibration bath with slowly increasing and decreasing temperature. TC305/TC303 measures the bath temperature and detects the actuation and deactuation of the switch. The accuracy of the method depends on the accuracy of the used reference sensor. Also the speed difference between the two sensors and high rate of the temperature change reduce the test accuracy.

TC305/TC303 shows the temperature measurement reading on the upper display. At the beginning the lower display shows only the state of the switch contact, e.g.

222.35

o

Increase the temperature until the switch actuates. Actuation of the switch freezes the actuation point temperature on the lower display.

241.60

c241.10

Let the temperature now decrease slowly. When the deactuation point temperature is found, it freezes on the upper display:

o115.15

c241.10

If the switch state changes back before TC305/TC303 has got the reading, it prompts you to repeat the test with the message

**ERROR-
REPEAT**

Storing the results

At the end of the test, you have the actuation and deactuation readings on the displays. You can now store them to any of the Working Memory locations 0 to 9 and +/- as explained in Chapter 4.2 in part B of this manual. Storing deletes old readings from the Working Memory. After storing TC305/TC303 prompts

**RCL=
REPEAT**

Press RCL to repeat the test or ESC to exit to the basic measure/generate operation.

3.5 Loading from and saving to the Data Memory

The TCAL Data memory and functions related to it are only available, if **TCAL305** expansion is installed. The TCAL Data Memory can hold instrument and calibration data of up to 44 instruments. For each instrument there are three sections; one for the instrument data, one for the As Found calibration and one for the As Left calibration.

Normally TC305/TC303 receives the instrument data from the **QCAL Software** database in a computer. You have to load the instrument data from the Data Memory before the calibration. If you already saved some calibration results, they will come to the Working Memory together with the instrument data. The Quick Store function stores the calibration results into the Working Memory. After the Quick Store function, you can save the results to the Data Memory. Finally, after calibrating all the required instruments, you can send the calibration results to the **QCAL Software** database in the computer.

The function menu entries for saving to the Data Memory and for loading from the Data Memory are:

FUNC

<SAVE>

(quick select FUNC STO)

and

FUNC

<LOAD>

(quick select FUNC RCL)

The use of these functions is explained in detail in part D of this manual, Chapters 5.1 (load) and 5.4 (save).

3.6 Clearing of memory

Sometimes it may be necessary to delete some instrument data and/or calibration results. For that purpose there is an entry in the function menu:

FUNC

<CLEAR>

(quick select FUNC 0)

These functions are only available, if TCAL305 expansion is installed. Pressing ENT in the main menu gives you a submenu:

a) **CLEAR**
<RESU>

Selecting this entry cleans a memory area from calibration results. Enter the memory area number to the prompt

AREA

?

Use the minus sign with As Found results and no sign with the As Left results. Use the memory area numbers 1 to 44 for Data Memory areas and 0 for the Working Memory. Press ESC to escape without cleaning any results.

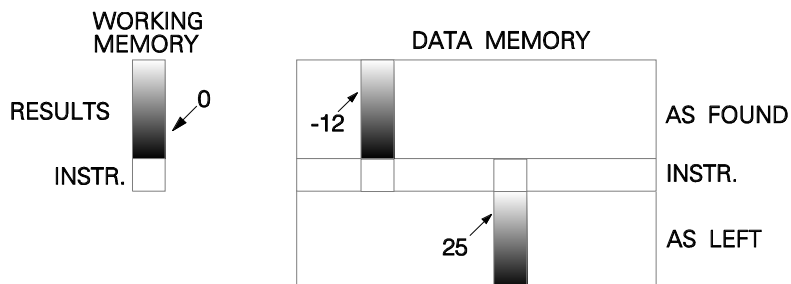

b) **CLEAR**
<AREA>

Selecting this entry deletes an entire memory area, both instrument data and calibration results. Enter the memory area number to the prompt

AREA
?

Use of the minus sign has no effect, both As Found and As Left results as well as instrument data will be deleted. Use the memory area numbers 1 to 44 for Data Memory areas and 0 for the Working Memory. Press **ESC** to escape without deleting anything.

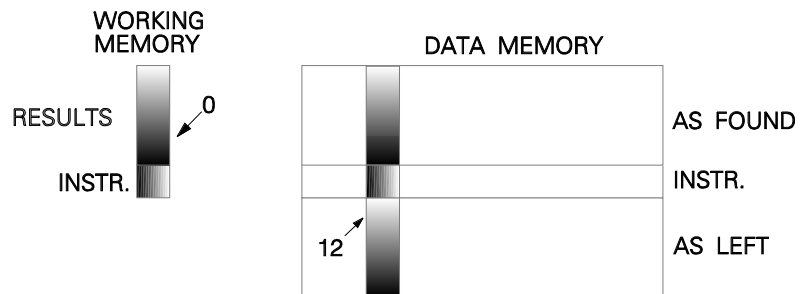

c) **CLEAR**
<ALL>

Selecting this entry deletes all data and results from the entire Data Memory. When you press the **ENT** key, TC305/TC303 shows the warning

ENT=
DEL.ALL

Press **ENT** again to delete or press **ESC** to escape without deleting anything.

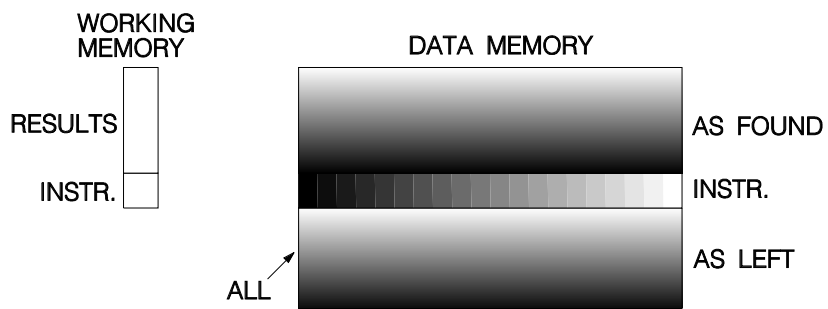

**TCAL305
EXPANSION**

1 GENERAL

TCAL305 is an optional expansion to TC305/TC303 programs. It makes TC305/TC303 part of the Beamex QCAL calibration system. This part of this manual explains the use of the TCAL305-expansion.

The functions concerning electrical limit switches or temperature limit switches (thermostats) can be used only if the Switch Calibration software option is installed.

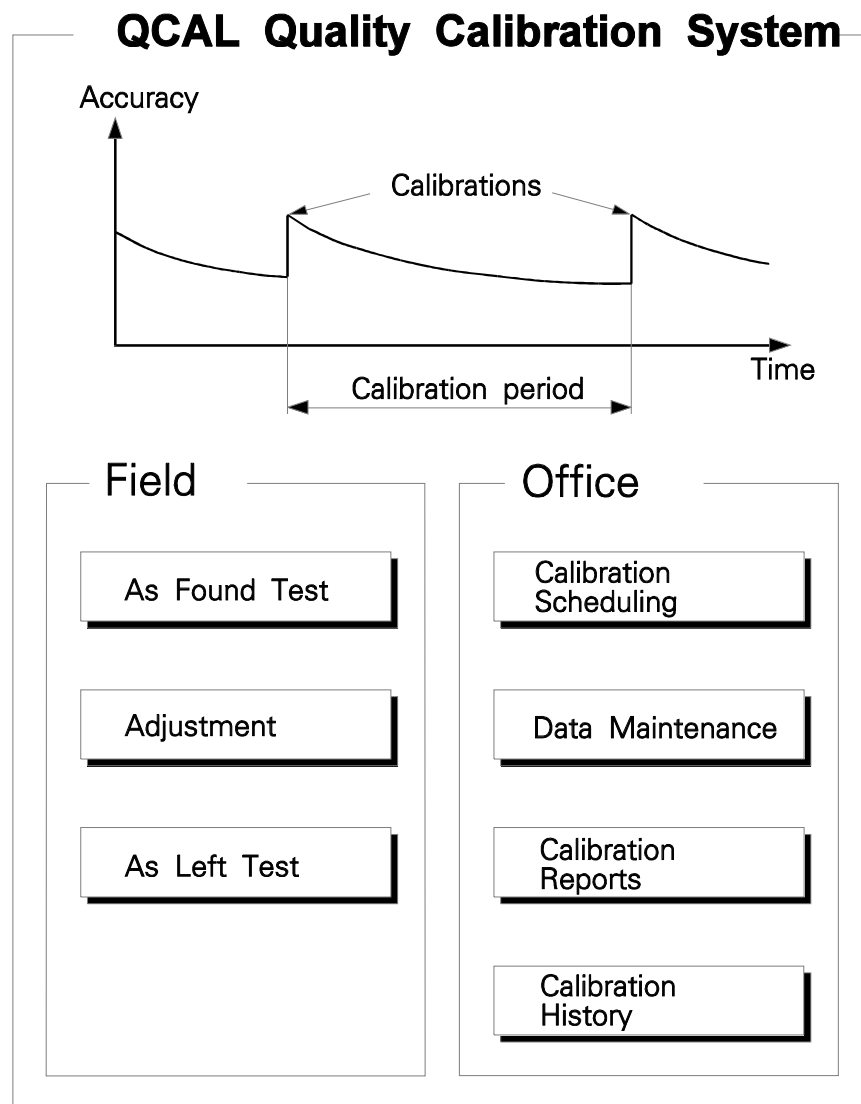

The TCAL305-expansion consists of the additional programs and memory enabling saving of calibration results and transferring data between TC305/TC303 and the computer.

The RS1 interface connects TC305/TC303 to any computer having 4800 bit/s RS-232 serial interface and a suitable software.

TC305/TC303 with TCAL305 expansion is part of the Beamex QCAL Quality Calibration System. The following list presents all QCAL calibration database software made by Beamex:

- **CALDB3** and it's history database option **HISDB3** in DOS environment
- **QD3** in Windows 3.x, Windows 95 and Windows NT environment
- **QM6** in Windows 3.x, Windows 95 and Windows NT environment

In the rest of this manual, all Beamex QCAL calibration database software will be referred to as **QCAL Software**.

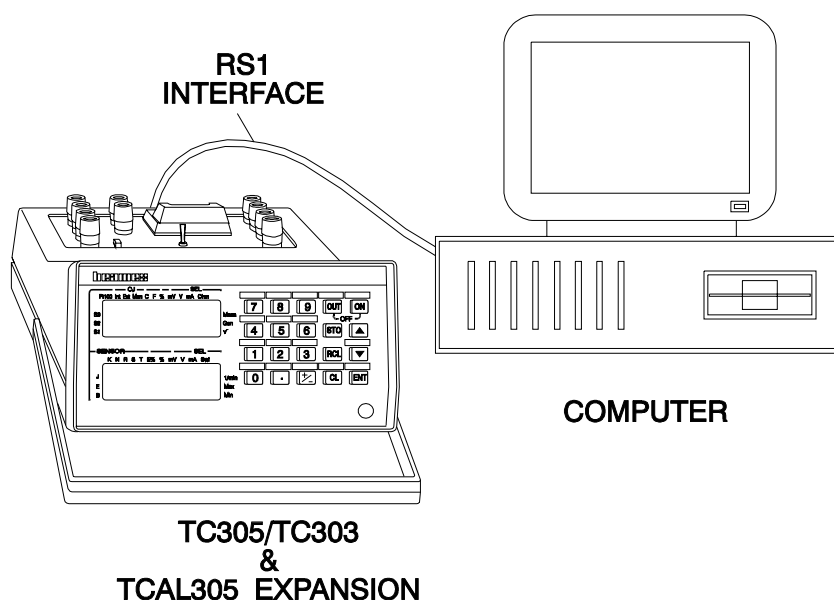

2 TC305/TC303 MEMORY

2.1 Working Memory

Without the TCAL305 expansion TC305/TC303 has memory space for 21 pairs of measurement/generation readings. We call this memory space the Working Memory.

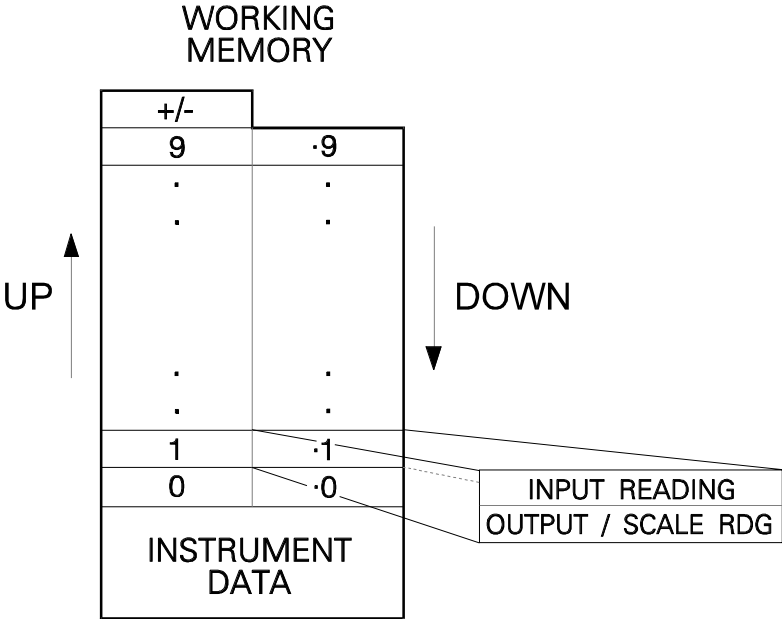

2.2 TCAL Data Memory

A TC305/TC303 calibrator with TCAL305-expansion features an additional memory for instrument data and calibration results. This Data Memory can contain instrument data and results from As Found and As Left tests for 44 instruments. The tests can be carried out in eleven points (0 ... 9, +/-) with increasing input signal and in ten points (.90) with decreasing input signal.

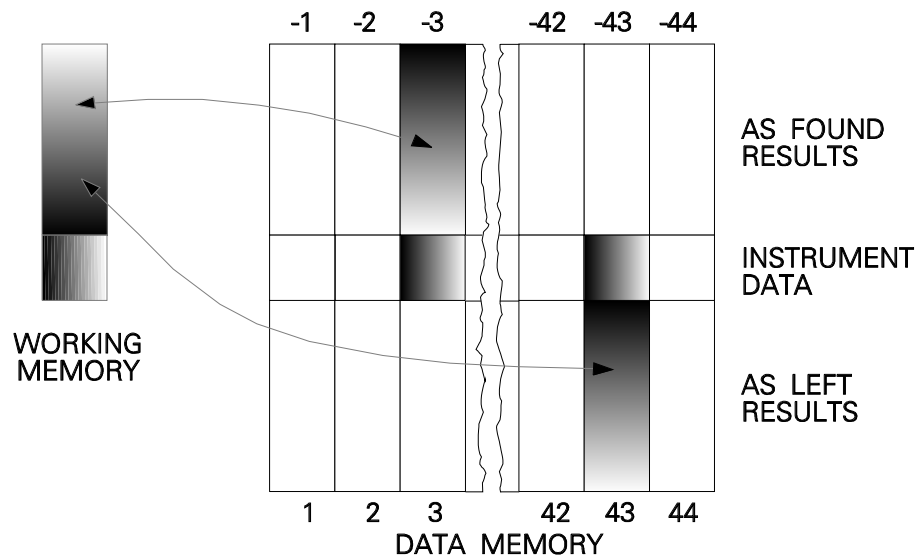

2.3 Use of memory areas

While sending instrument data to TC305/TC303, The **QCAL Software** automatically prints a list of the instruments you should calibrate. The list includes the number of the used memory area for each instrument and also some additional data about the instrument.



3 PHASES OF THE INSTRUMENT CALIBRATION

There are three main phases in the instrument calibration:

- * **As Found test**
- * **Adjustment**
- * **As Left test.**

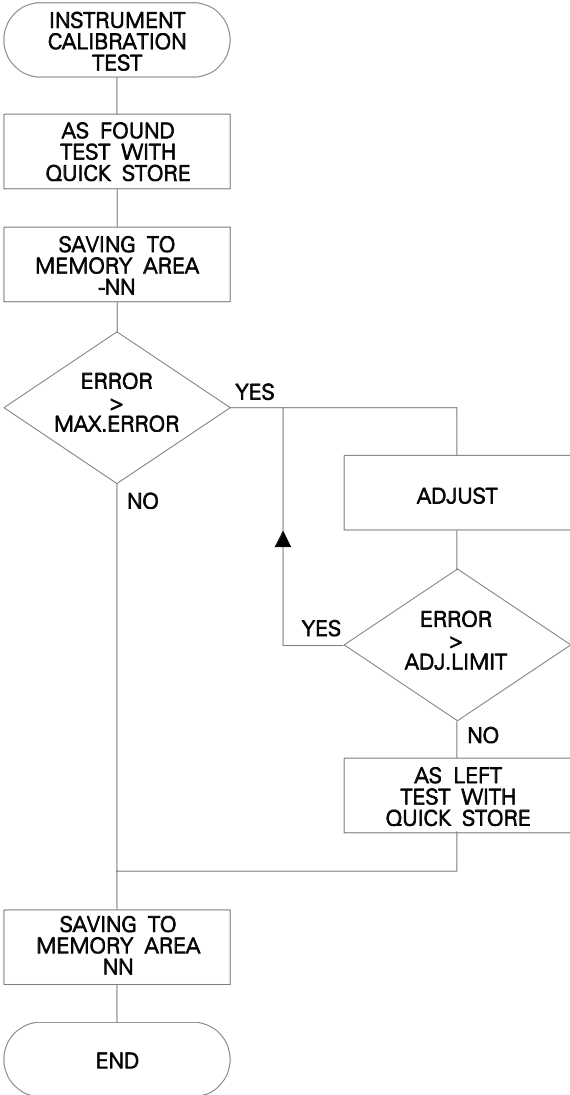

3.1 As Found test

The As Found test documents the state of the calibration before carrying out any adjustments. Many users see this very important, because it shows how much drift there has occurred in the calibration during the calibration period.

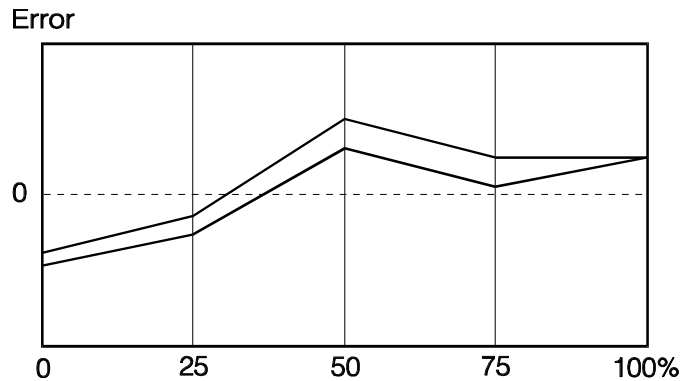

Use the Quick Store function explained in Chapter 5 for storing the test readings.

The Quick Store function stores the results only in the Working Memory. Save the Working Memory contents in the TCAL Data Memory before the next Quick Store function. When saving the As Found test results, use a leading minus sign in the Memory Area number. See Chapter 5.4 for saving to Data Memory.

Carrying out the As Found test is not necessary. If you omit the test, however, make sure that there are no old As Found test results in that area of the Data Memory. When you download instrument data to a memory area, TC305/TC303 automatically cleans the area from old results. Clearing of memory is explained in the part C of this manual in Chapter 3.6.

If you always carry out the As Left test only, configure the **QCAL Software** database software accordingly.

3.2 Adjustment

Adjustment of the calibration may be necessary, if the found error exceeded the allowed maximum value in the As Found test. There is no special function for the adjustment, but using the percentage error display makes it very easy.

Minimise the error reading at both ends of the range. Use the instrument ZERO adjustment at lower end of the range. Adjust the higher end of the range with the instrument SPAN adjustment.

Use two temperature baths, if you calibrate a temperature measuring instrument together with the sensor. One bath should be controlled near to the lower end of the range for zero adjustment. Adjust span in another bath near to the higher end of the range.

The two adjustment points do not necessarily need to be the end points of the instrument range. You may want to use other points to optimise the calibration at the most important part of the range. This is particularly easy with the percentage error display of TC305/TC303. Note, however, that if the points are very close to each other, the error at other points of the range may be quite big.

If the percentage error reading exceeds the recommended adjustment limit, the reading will blink. If possible, reduce the calibration error smaller than the adjustment limit. Defining the recommended adjustment limit is possible only in the **QCAL Software** calibration database system.

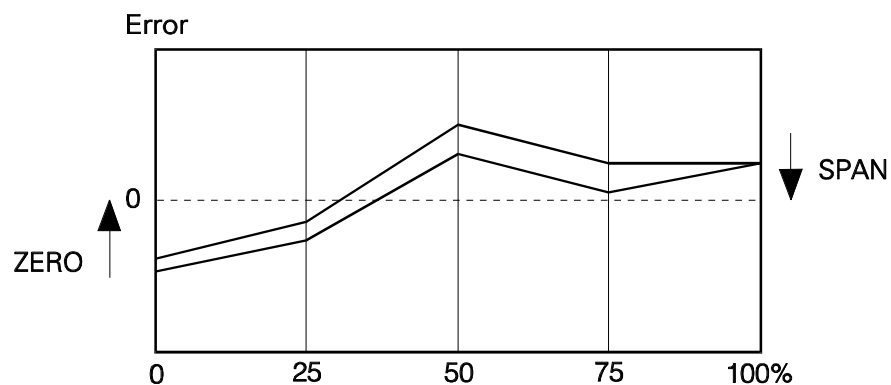

3.3 As Left test

The As Left test is the final test after the possible adjustment. It documents the final state of the instrument calibration. Use the Quick Store function to carry out the As Left test.

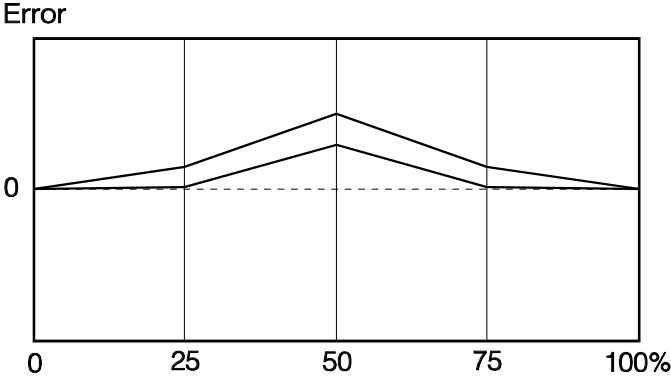

If you already found the calibration of the instrument acceptable in the As Found test, the As Left test is not necessary. Make sure, however, that there are no results from an earlier As Left test in the Data Memory. When you download instrument data from the computer to a memory area, TC305/TC303 automatically cleans the area from old results. If you are not sure, that there are no old As Left results, save the As Found test results to both sides of the memory area.

4 INSTRUMENT DATA

TC305/TC303 needs the following instrument data during the calibration:

- * measurement unit
- * input range
- * reference junction mode / reference temperature
- * output signal range or indicator scale
- * linear/rooting operation
- * setpoint delay
- * calibration points (*)
- * required actuation and deactuation points of limit switches
- * allowed scanning limits for testing of limit switches
- * instrument function type
- * instrument identifier (tag number or serial number).

It uses also the following data, if available:

- * allowed maximum error
- * recommended maximum error in adjustment.

4.1 Instrument data from QCAL Software Database

You can pick up the instrument data from the **QCAL Software** database and transfer to the TC305/TC303 Data Memory.

Recalling instrument data from Data Memory to Working Memory sets all instrument parameters as defined in the database. If the calibration points are left open in the database, TC305/TC303 automatically defines the according to its default settings(*). In this case you can alter the points as explained in part C of this manual.

(*) Note: If the calibration points are not given, then TC305/TC303 sets them according to the settings in the quick selection CONF 5.

4.2 User entered instrument data

While using the **QCAL Software** database system, you can send instrument data from the system to TC305/TC303. Otherwise you must enter instrument data manually to the calibrator.

Entering of the instrument data is not necessary, if the instrument data was earlier saved to the TCAL Data Memory. To get the saved data, load it to the Working Memory as explained in Chapter 5.1.

Basic configurations, like the use of the SEL, T/EL, SENSOR, CJ, °C/°F, 0% and 100% keys are explained in the part B of this manual. More advanced configurations are carried out in the configuration menu as explained in the part C of this manual. Detailed lists of necessary configurations for different instrument function types and input methods are in this part of the manual in Chapter 6.

5 TESTING INSTRUMENT CALIBRATION

5.1 Loading data from Data Memory

You can load instrument data from the Data Memory to the Working Memory. Calibration results - if exist - will be loaded too. Each Memory Area in the Data Memory has space for instrument data and calibration results. A leading minus sign in the Memory Area number refers to the As Found test results. A Memory Area number without sign refers to the As Left test results. The instrument data is common for both sides of a Memory Area.

If the instrument data came from the computer, possible old calibration results were deleted from the memory area.

Instrument data and the results of the As Left test (if available) are loaded from the Memory Area 5 by keying

FUNC RCL

When the display prompts

LOAD

enter the number of the Memory Area:

5 ENT

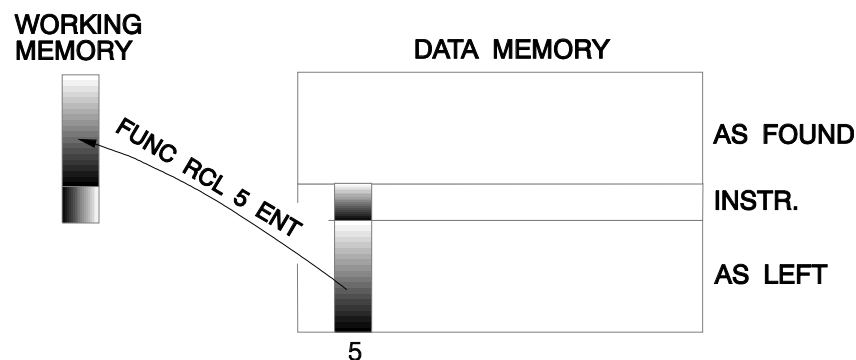

The instrument identifier (tag number or serial number) is now shown. Check that this is the instrument you wanted and press ENT. The calibrator now configures itself according to the loaded instrument data. TC305/TC303 does not let you to alter instrument data coming from the calibration database. The input and output ranges you can, however, alter if necessary. When returning the results to the database, **QCAL Software** shows, that the range(s) have been changed.

Warning messages for instrument without identifier or empty Memory Area are

NO ID

and

**CLEAR
AREA**

The data of another instrument in memory area 22 with the results from the As Found test (if available) could have been loaded by keying

□FUNC □RCL

and by answering to the prompt

LOAD

with negative Memory Area number:

□+/- □2 □2 □ENT

Use of the minus sign is necessary only if you want to look at the As Found test results, already deleted from the Working Memory.

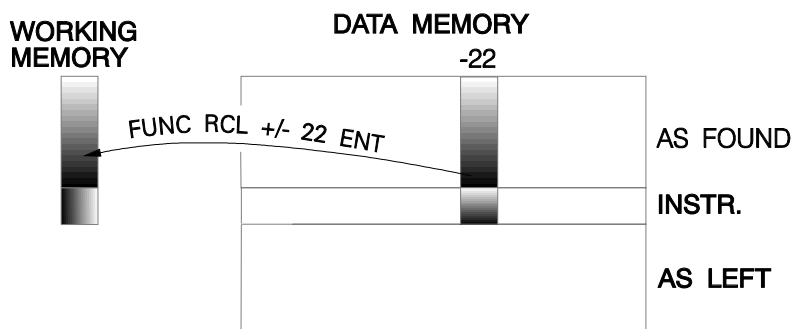

If the results of the previous test in the Working Memory have not been saved to the Data Memory, TC305/TC303 cancels the loading of new data and flashes the message

**NOT
SAVED**

You can save the Working Memory contents to some Memory Area in the Data Memory if you wish. Retrying overwrites the Working Memory.

If you try to load a temperature instrument having an unknown sensor type, TC305/TC303 denies the loading with the message

**SENSOR
nn BAD**

If you have the additional basic sensor number nn installed but not fixed to any of the special sensor places S1 to S3, fix it to one of them and retry to load the instrument.

Instrument data loaded from the Data Memory does not affect the display mode settings. You can freely change the mode settings before starting the Quick Store function.

5.2 Pre-operations and Quick Store

5.2.1 Start of the Quick Store function

Quick Store is a common name for the process that TC305/TC303 uses to test the calibration of an instrument. The way how it functions depends on the function type and input mode of the instrument under test.

Configure TC305/TC303 for calibration of the instrument under test, except if you loaded the data from the TCAL Data Memory. Check the test wiring. Make sure that the test arrangement functions properly.

If the display modes are not the preferred ones, set the suitable modes before starting the Quick Store.

Normally you cannot alter the calibration points coming from the **QCAL Software** calibration database. If, however, the calibration database leaves the calibration points open, TC305/TC303 selects preliminary points 0, 25, 50, 75 and 100%. In this case you can alter them as you wish before starting the Quick Store function.

In order to start the Quick Store function, press

□STO □STO

If the results of the previous Quick Store have not yet been saved in the Data Memory, TC305/TC303 cancels the Quick Store function and flashes the message

**NOT
SAVED**

You can now save the contents of the Working Memory to a suitable Data Memory area. If you don't need the readings in the Working Memory, just restart the Quick Store function and TC305/TC303 automatically clears the old readings in the Working Memory.

The further function of the Quick Store depends on the selected instrument function type. If the TC305/TC303 settings are not in accordance with the selected instrument function type or if the selected type is FREE, you cannot carry out the Quick Store function. In this case TC305/TC303 flashes the message

**CONFIG
ERROR**

and returns to the basic measure/generate function.

If there are no calibration points defined, you cannot carry out the Quick Store function. In this case TC305/TC303 flashes the message

**NO CAL
POINTS**

and returns to the basic measure/generate function.

If the instrument type under test with the selected input method cannot be calibrated automatically, the message

**Q.STORE
MANUAL**

flashes for a moment and you can start storing of the readings to the Working Memory.

If automatic calibration is possible for the instrument type under test, the following menu is displayed:

**Q.STORE
< UP >**

**Q.STORE
< UP-DN >**

**Q.STORE
<MANUAL>**

If the instrument data came from the database, default selection is the one selected in the database. If necessary, scan the menu with the up/down-keys and make the selection by pressing the key ENT.

- * Select UP to test with increasing input only.
- * Select UP-DN to test with increasing input to the last point and with decreasing input back to the first point. This enables testing of the instrument hysteresis.
- * Select MANUAL, if you want to accept each point by pressing STO. Also in this case all points from the first to the last and back to the first will be scanned, unless you press ESC to interrupt the sequence.

If the instrument under test is an electrical limit switch or a temperature switch (thermostat) without sensor, you have the following two choices in the Quick Store menu:

**Q.STORE
< AUTO >**

**Q.STORE
<MANUAL>**

AUTO is a fully automatic test repeated as many times as defined in the configuration.

In the MANUAL test you have to accept (key STO) or reject (key RCL) each couple of actuate/deactuate readings. The test repeats as many times as defined in the configuration, unless you press ESC to interrupt the sequence.

The Quick Storing proceeds point by point controlled either manually or automatically. At the beginning of the calibration of each point the entry display of the calibration point flashes. The upper display shows the instrument function type. The lower one indicates the input method and the number of the calibration point (0 to 9, -, .9 to .0). The purpose of the display is to remind about the type and phase of the test going on.

While displaying the actual calibration readings, flashing arrows on the right or left side of the lower display show, whether the instrument input is increasing or decreasing.

TC305/TC303 stores each couple of calibration readings to the respective memory. While storing, the display shows the text

STO n

where n is 0 to 9, -, .9 to .0. Calibration in the points 0%, 25%, 50%, 75%, 100%, 75%, 50%, 25% and 0%, for instance, is stored in memories 0 to 4, .3, .2, .1 and .0.

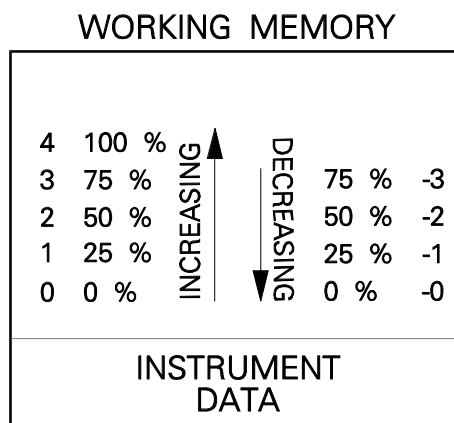

During the Quick Store function you can go backwards in the sequence by pressing the key \square RCL:

- * Normally it comes back to the previous calibration point.
- * If you are calibrating a temperature transmitter (TT) with the input method MEA, you can re-check the preset calibration point by pressing \square RCL and if you press another time, you will come to the previous point.
- * In switch calibrations \square RCL also functions on two levels: if no actuating/deactuating values have yet been captured on the display, pressing \square RCL restarts previous test, otherwise it rejects the captured value(s) on the display and restarts the current test.

If you want to interrupt the Quick Store function (also in automatic storing), press the key \square ESC.

While calibrating a limit switch or thermostat, you can repeat the instrument function test up to 10 times. TC305/TC303 stores the actuation/deactuation readings in the memories 0 to 9. It uses the other memories for some calculated parameters.

5.2.2 Temperature transmitters and electrical converters

5.2.2.1 Configuration

Instrument function type and input method for temperature transmitters are:

TT = temperature transmitter
SIM = sensor simulated by TC305/TC303.

The respective configuration for electrical converters is:

EEC = electrical converter
GEN = input generated by TC305/TC303.

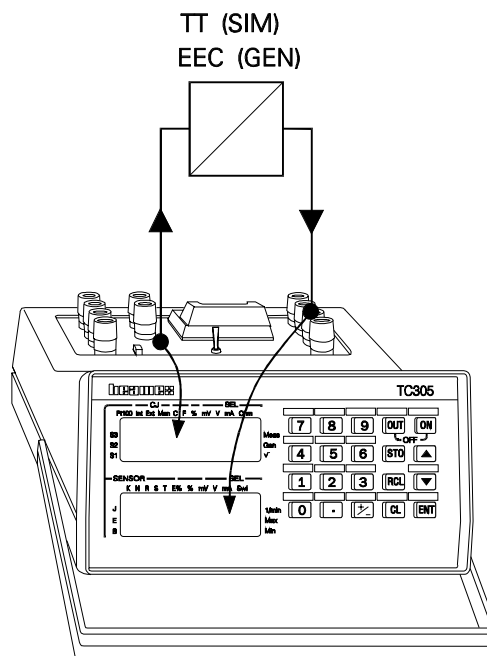

See Chapter 6.2, how to manually enter instrument data to configure TC305/TC303 for temperature transmitter or electrical converter calibration. Normally instrument data comes from the calibration database and all parameters are set automatically. In this case you can alter only the input and output range limits, if necessary.

- * Select suitable display modes before starting the Quick Store function.
- * Turn the MEASURE/GENERATE-switch to position GENERATE.
- * Connect the TC305/TC303 output signal from the proper A-section terminals to the instrument input.
- * Connect the instrument output to the proper B-section terminals.
- * Test the function of the configuration by generating/simulating different input signals to the instrument and read the output.

5.2.2.2 Quick Store

TC305/TC303 carries out the test fully automatically. TC305/TC303 generates/simulates the instrument input and reads the output. Each calibration point starts with the entry display. Then the upper display shows the generated/simulated value. The measured output signal or its error is on the lower display. If the first calibration point is e.g. 0°C and the output error - 0.05%, the displays would be

0.00
-0.05>

If you selected manual approval of calibration points, TC305/TC303 waits at each calibration point until you press STO. If you didn't select manual approval, TC305/TC303 stores readings automatically after the preset setpoint delay.

5.2.3 Indicators and recorders

5.2.3.1 Configuration

The instrument function type and the input method for temperature indicators and recorders are:

TIR = temperature indicator or recorder
SIM = sensor simulated by TC305/TC303.

The respective configuration for electrical indicators and recorders is:

EIR = electrical indicator or recorder
GEN = input generated by TC305/TC303.

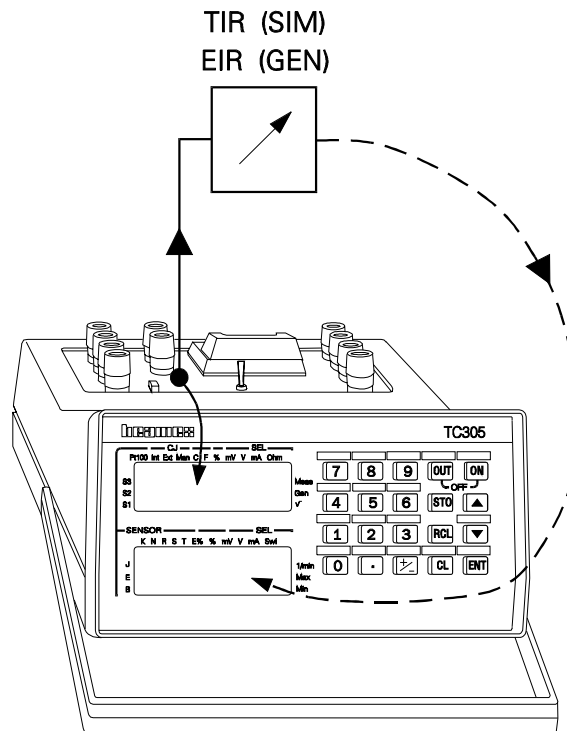

See Chapter 6.3, how to manually enter instrument data to configure TC305/TC303 for indicator or recorder calibration. Normally data comes from the calibration database and all parameters are set automatically. In this case you can alter only the input range and scale limits, if necessary.

- * Select suitable display modes before starting the Quick Store function. The percentage error mode acts like the percentage mode, except in the Quick Examine function.
- * Turn the MEASURE/GENERATE-switch to position GENERATE.
- * Connect the TC305/TC303 output signal from the proper A-section terminals to the instrument input.
- * Test the function of the configuration by generating/simulating different input signals to the instrument and check the instrument reading.

5.2.3.2 Quick Store

TC305/TC303 cannot read the actual reading of the instrument. This makes it impossible to carry out the calibration of indicators or recorders fully automatically. TC305/TC303 generates/simulates the instrument input for each calibration point. You must adjust the calibrator output, until the instrument indicates the exact calibration point value. You can also key in the actual instrument reading, if you see it easier.

Each calibration point starts with the entry display. Then the upper display shows the generated/simulated value. The exact indicator/recorder reading is on the lower display. Use the up/down-keys to adjust the generated/simulated signal, until the instrument under test shows exactly the reading displayed on the lower display. Press the key \square STO to store the readings.

With digital indicators it is often difficult to adjust the digital reading exactly to a certain value. It is easier to key in the actual reading without trying to adjust it. If the generated current is e.g. 16mA and instrument reading should be 75%, the displayed readings are

16.000

75.00>

The lower display will be cleared when you start keying the actual reading, e.g.

\square 7 \square 4 \square . \square 8 \square 9 \square ENT

Now the displayed readings are

16.000

74.89>

If necessary, you can re-enter the reading. If it is o.k., accept by pressing

\square STO

5.2.4 Thermometers

5.2.4.1 Configuration

Instrument function type and input method for thermometers are:

TIR = thermometer

MEA = reference measurement with TC305/TC303.

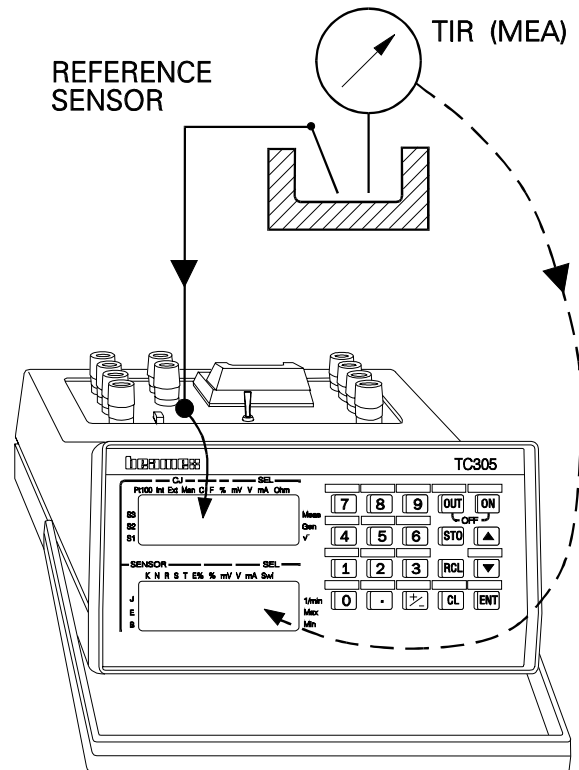

See Chapter 6.4, how to manually enter instrument data to configure TC305/TC303 for thermometer calibration. Normally data comes from the calibration database and all parameters are set automatically. In this case you can alter only the input range and scale limits, if necessary.

- * Select suitable display modes before starting the Quick Store function. The percentage error mode acts like the percentage mode, except in the Quick Examine function.
- * Turn the MEASURE/GENERATE-switch to position MEASURE.
- * Connect a good quality sensor of the type shown on the display and place it to the calibration bath together with the sensor of the thermometer under test.

5.2.4.2 Quick Store

TC305/TC303 cannot set the temperature of the calibration bath or read the readings of the thermometer. This makes it impossible to calibrate thermometers fully automatically. You have to set the temperature of the bath for each calibration point. TC305/TC303 uses the connected reference sensor to measure the bath temperature, but you must key in the thermometer reading.

Each calibration point starts with the entry display. Then the upper display shows the bath temperature measured with the reference sensor. The exact thermometer reading is on the lower display. If the measured temperature is, say, 239.5°C and the pre-defined exact reading 240°C, the displays would be

239.50
240.00>

Read the actual reading from the thermometer and enter it to the calibrator, e.g.

239 ENT

The readings

239.50
239.00>

stay now on the display. Accept the readings by pressing

□STO

5.2.5 Temperature sensors

5.2.5.1 Configuration

Instrument function type and input method for temperature sensors are:

TE = temperature sensor

KEY = actual temperature keyed (if necessary) into TC305/TC303.

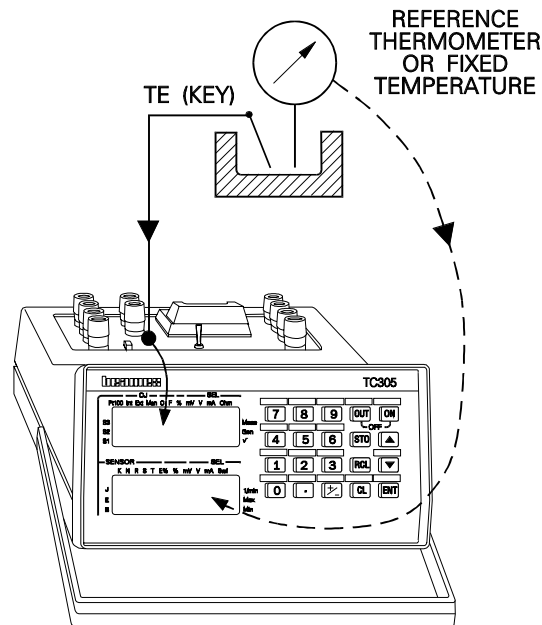

See Chapter 6.5, how to manually enter instrument data to configure TC305/TC303 for temperature sensor calibration. Normally data comes from the calibration database and all parameters are set automatically. In this case you can alter only the temperature range limits, if necessary.

- * Select suitable display modes before starting the Quick Store function. The percentage error mode acts like the percentage mode, except in Quick Store and Quick Examine functions.
- * Turn the MEASURE/GENERATE-switch to position MEASURE.
- * Connect the sensor to be tested and place it to the calibration bath.

5.2.5.2 Quick Store

TC305/TC303 cannot set or measure the real temperature of the calibration bath. This makes it impossible to calibrate temperature sensors fully automatically. You have to set the temperature of the bath for each calibration point. TC305/TC303 reads the output of the sensor, but you must key in the real bath temperature. You may measure the bath temperature with a separate indicator using a precision sensor. You can also use fixed point cells (freezing/melting point, triple point, boiling point). Each fixed point cell needs its own maintenance bath and you must put the sensor to each cell in its turn.

Each calibration point starts with the entry display. Then the upper display shows the sensor output (converted to temperature). The preset calibration temperature is on the lower display. If the temperature calculated from the measured sensor output is, say, 239.5°C and the predefined calibration point 240°C, the displays would be

239.50
240.00>

Read the actual reading from the reference thermometer and enter it to the calibrator, e.g.

□2 □3 □9 □ENT

The readings

239.50
239.00>

stay now on the displays. If the real temperature is equal to the pre-defined value, entering of the new reading is not necessary. This is normally the case with the fixed point cells.

In the percentage error display mode, the error is calculated from the latest entered reading. The pre-defined calibration point is used at the beginning.

Accept the readings by pressing

□STO

5.2.6 Temperature transmitters with sensor

5.2.6.1 Configuration

Instrument function type for temperature transmitters with sensor is

TT = temperature transmitter.

The choices for the input method are:

- a) KEY = actual temperature keyed (if necessary) into TC305/TC303,
- b) MEA = reference measurement with TC305/TC303.

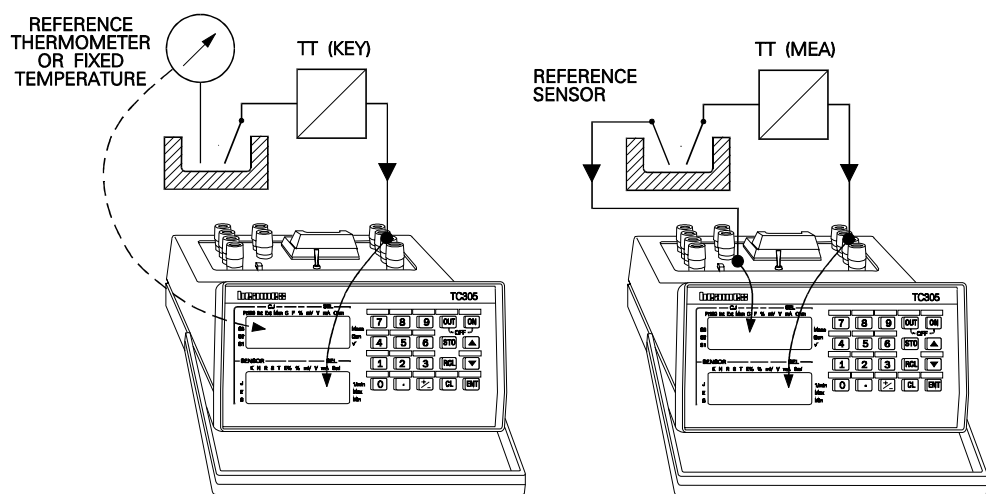

See Chapter 6.6, how to manually enter instrument data to configure TC305/TC303 for calibration of temperature transmitters with sensor. Normally data comes from the calibration database and all parameters are set automatically. In this case you can alter only the input and output range limits, if necessary.

- * Select suitable display modes before starting the Quick Store function. With the input method KEY, the percentage error mode acts like the percentage mode, except in Quick Store and Quick Examine functions.
- * Connect the transmitter output to the TC305/TC303 B-section terminals and place its sensor to the calibration bath.

You can measure the bath temperature with a separate precision thermometer. You can also use fixed point cells to generate known temperatures. If you use the TC305/TC303 A-section for reference measurement, carry out the following additional configurations:

- * Turn the MEASURE/GENERATE-switch to position MEASURE.
- * Connect a good quality temperature sensor of the type shown on the display and place it to the calibration bath together with the sensor of the transmitter under test.

5.2.6.2 Quick Store

TC305/TC303 cannot set the temperature of the calibration bath. This makes it impossible to calibrate temperature transmitter with sensor fully automatically. You have to set the temperature of the bath for each calibration point. TC305/TC303 reads the output of the transmitter, but you must key in the real bath temperature. You may measure the bath temperature with a precision sensor connected to TC305/TC303 A-section terminals or to a separate precision temperature indicator. Alternatively you can use fixed point cells (freezing/melting point, triple point, boiling point). Each fixed point cell needs its own maintenance bath and you must put the sensor to each cell in its turn.

A) Separate temperature measurement or fixed temperature points

Each calibration point starts with the entry display. Then the upper display shows the predetermined calibration temperature. The transmitter output is on the lower display. If the transmitter output is, say, 11.489mA and the pre-defined calibration point 240°C, the displays would be

240.00
11.489>

Read the actual reading from the reference temperature indicator and enter it to the calibrator, e.g.

239 ENT

The readings

239.00
11.489>

stay now on the displays. If the real temperature is equal to the pre-defined value, entering of the new reading is not necessary. This is normally the case with the fixed point cells.

In the percentage error display mode, the error is calculated from the latest entered reading. The pre-defined calibration point is used at the beginning.

Accept the readings by pressing

□STO

B) Reference temperature measurement with TC305/TC303

Each calibration point starts with the entry display. After that TC305/TC303 shows the pre-defined calibration temperature and the number of the calibration point, e.g.

240.00
CALP4>

Take notice of the temperature and press

ENT

to continue. The upper display shows the measured temperature. The transmitter output is on the lower display. If the transmitter output is, say, 11.489mA and the measured temperature 239.6°C, the displays would be

239.6

11.489>

Accept the readings by pressing

STO

5.2.7 Limit switches and thermostats without sensor

5.2.7.1 Configuration

Instrument function type and input method for electrical limit switches are:

ESNO/ESNC = NO/NC electrical limit switch

GEN = input generated by TC305/TC303.

The respective configuration for temperature limit switches is:

TSNO/TSNC = temperature limit switch (thermostat)

SIM = input simulated by TC305/TC303.

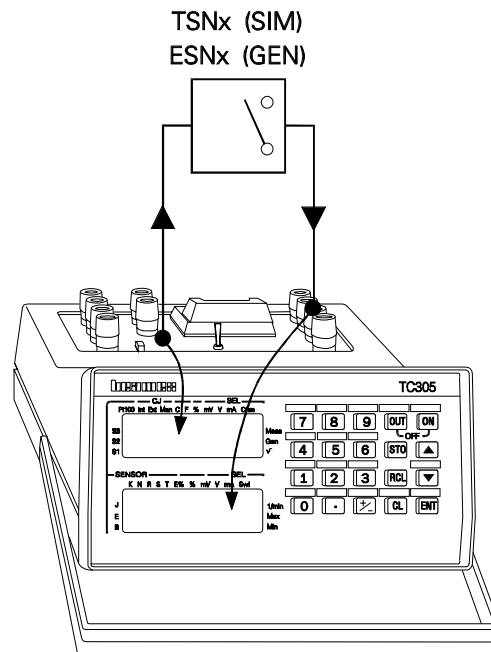

See Chapter 6.7, how to manually enter instrument data to configure TC305/TC303 for limit switch calibration. Normally data comes from the calibration database and all parameters are set automatically. In this case you can alter only the

actuating/deactuating points and scan limits, if necessary.

- * Select suitable display mode for the upper display before starting the Quick Store function.
- * Turn the MEASURE/GENERATE-switch to position GENERATE.
- * Connect the TC305/TC303 output signal from the proper A-section terminals to the instrument input.
- * Connect the switch contact to the proper TC305/TC303 B-section terminals.
- * Test the function of the configuration by generating/simulating different input signals to the instrument and read the switch state on the lower display.

5.2.7.2 Quick Store

TC305/TC303 carries out the test fully automatically. Before the actual test it runs a preliminary test. In the preliminary test TC305/TC303 will find out the limits for scanning the actuating and deactuating points in the final test. This speeds up the final test without sacrificing accuracy. TC305/TC303 shows the text

SCAN

during the preliminary test. The lower display counts the scanned points.

TC305/TC303 knows from the preliminary test the approximate ranges for the limit switch actuation and deactuation. In the final test TC305/TC303 scans the limit switch input through these ranges to detect the accurate actuation and deactuation points. While scanning for the actuation point of a normally open limit switch, the upper display shows the increasing input value, e.g.

234.35

o >

The input value needed to close the switch contact (actuation point) freezes on the lower display while the upper display shows the scanning value for the deactuation point:

124.20

<c241.10

When found, the deactuation point value freezes to the upper display:

o115.15

c241.10

If you selected automatic storing, these values only flash and the test repeats as many times (up to 10) as defined in the instrument data. If you selected manual approval of the results, press STO to store the values.

5.2.8 Temperature limit switches (thermostats) with sensor

5.2.8.1 Configuration

Instrument function type and input method for temperature limit switches with sensor are:

TSNO/TSNC = temperature limit switch (thermostat)

MEA = reference measurement with TC305/TC303.

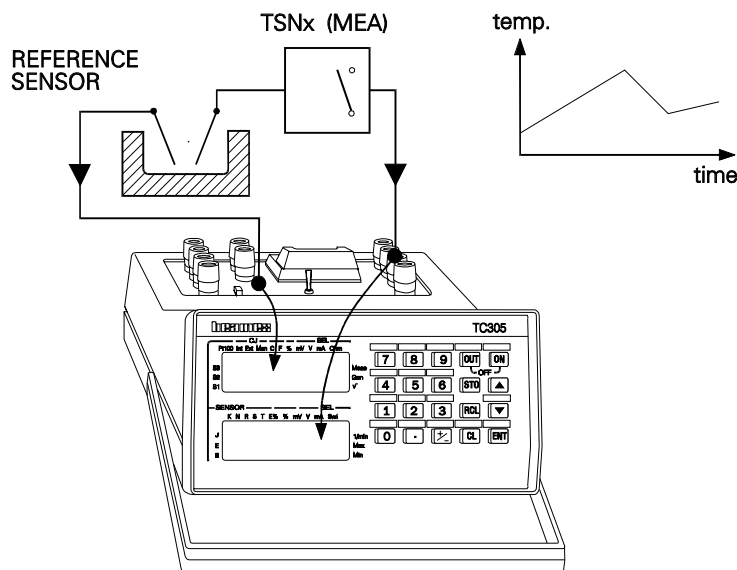

See Chapter 6.8, how to manually enter instrument data to configure TC305/TC303 for temperature limit switch calibration. Normally data comes from the calibration database and all parameters are set automatically. In this case you can alter only the actuating/deactuating points and scan limits, if necessary.

- * Select suitable display mode for the upper display before starting the Quick Store function.
- * Turn the MEASURE/GENERATE-switch to position MEASURE.
- * Connect a good quality temperature sensor of the type shown on the display and place it to the calibration bath together with the sensor of the temperature switch under test.
- * Connect the switch contact to the TC305/TC303 B-section terminals.

5.2.8.2 Quick Store

Testing of temperature switches with integral sensor is controlled manually. To test such a switch, use a calibration bath with slowly increasing and decreasing temperature. TC305/TC303 measures the bath temperature and detects the actuation and deactuation of the switch. The accuracy of the method depends on the accuracy of the used reference sensor. Also the speed difference between the two sensors and high rate of the temperature change reduce the test accuracy.

TC305/TC303 shows the temperature measurement reading on the upper display and indicates the required direction of change with the blinking arrows. At the beginning the lower display shows only the state of the switch contact, e.g.

222.35
o >

Actuation of the switch freezes the actuation point temperature on the lower display. The blinking arrows on the upper display prompt you to alter the direction of the temperature change.

241.60
<c241.10

When the deactuation point temperature is found, it freezes on the upper display:

o115.15
c241.10

The readings are stored by pressing the key

□STO

5.2.9 TC305/TC303 measurement and generation ranges

5.2.9.1 Configuration

Instrument function type for calibrator ranges is

TRC = calibrator temperature range or
ERC = calibrator electrical range.

The input method is

EXT for A-section measurement ranges,
GEN for electrical generation ranges,
SIM for temperature simulation ranges and
- for B-section measurement ranges.

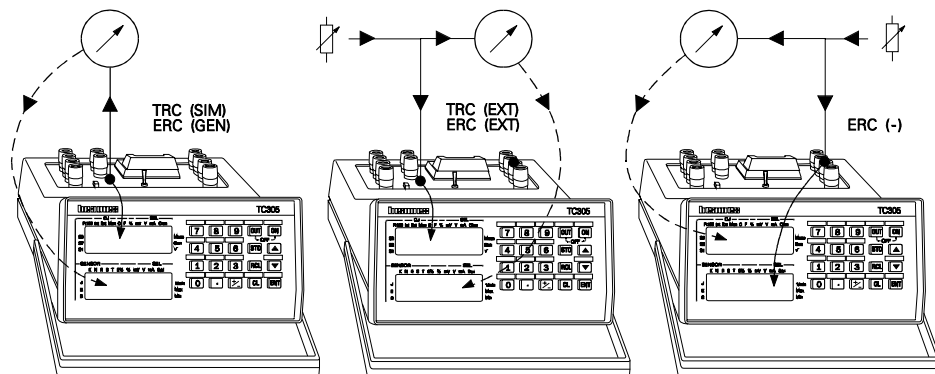

See Chapter 6.9, how to manually enter instrument data to configure TC305/TC303 for testing of its own measurement and generation ranges. Normally data comes from the calibration database and all parameters are set automatically. In this case you can alter only the range limits, if necessary.

- * Select suitable display modes for the displays before starting the Quick Store function. The percentage error mode acts like the percentage mode, except in the Quick Examine function.
- * Turn the MEASURE/GENERATE-switch to the proper position.
- * Depending on the input method, connect whether a precision calibrator or a precision measurement device to the proper input/output terminals of TC305/TC303.

5.2.9.2 Quick Store

A) A-section measurement ranges

Apply an accurate value of each calibration point from a precision calibrator. TC305/TC303 shows its own reading on the upper display. The lower display shows the pre-defined value of the calibration point. The displays could be e.g.

250.05
240.00>

This means, that the pre-defined calibration point is 240°C and the TC305/TC303 own display is 250.05°C. If the real simulated temperature, however, is 250°C, enter it to the lower display:

250 ENT

The displays are now

250.05
250.00>

Accept the readings by pressing the key

□STO

B) B-section measurement ranges

Apply an accurate value of each calibration point from a precision calibrator. TC305/TC303 shows its own reading on the lower display. The upper display shows the pre-defined value of the calibration point. The displays could be e.g.

12.000
11.999>

This means, that the pre-defined calibration point is 12mA and the TC305/TC303 own display is 11.999mA. You can re-enter the upper display value, if necessary, but normally you only need to accept the readings by pressing the key

□STO

C) A-section generation/simulation ranges

In generation mode the upper display shows the generated or simulated value. The pre-defined calibration point is on the lower display. At the beginning the readings are equal, for instance

240.00
240.00>

If the used reference meter shows different reading, enter its reading to TC305/TC303 lower display, e.g.

□2 □3 □9 □. □8 □5 □ENT

Now the readings are

240.00
239.85>

Alternatively, you can use the up/down keys to adjust the generated/simulated output, until the reference meter shows the same reading as the lower display.

In both cases, accept the readings by pressing the key

□STO

5.2.10 End of the Quick Store function

You can always interrupt the Quick Store function - also with automatic storing - by pressing the key

□ESC

If you stored at least one calibration point during the test, TC305/TC303 shows one of the texts

PASS FAIL FND.ERR

PASS or FAIL indicates, whether the max. error was within the accepted limits or not (you can enter the error limit only in the **QCAL Software** database). If the error limit was not defined, TC305/TC303 uses the message FND.ERR.

The lower display shows the maximum found percentage error. If the error is not within the 'Adjust limit' specified in the **QCAL Software** database, the error reading blinks.

When you have noticed the found error, press any key to free the display, e.g.

□ESC

If you interrupted the Quick Store function before storing any readings, the display flashes

**CANCEL
STORE**

The message

**END OF
STORE**

flashes at the end of Quick Storing a limit switch or thermostat. Because there is no generally accepted way to describe the calibration quality of such an instrument, TC305/TC303 calculates several characteristic values during the Quick Store function. You can examine these calculated values by using the following commands:

□RCL □. □0	average switch opening and closing
□RCL □. □1	min/max switch opening
□RCL □. □2	min/max switch closing
□RCL □. □3	average hysteresis
□RCL □. □4	min/max hysteresis
□RCL □. □5	max errors in opening and closing
□RCL □. □6	maximum allowed calibration error
□RCL □. □7	recommended error limit in adjustment

Errors are shown in electrical or temperature units. The two latest values are shown only if they have been received from the computer.

5.3 Quick Examining calibration results

If you want to examine the calibration results stored in the Working Memory, press

□RCL □RCL

The first couple of results appears on the displays. You will get a new couple of readings for each pressing of the key

□RCL

At the end of the function (or if you press CL during the Quick Examining) TC305/TC303 shows the maximum found error just as in the Quick Store function. With electrical and temperature limit switches you will see at the end the calculated characteristics in the memories .7 to .0 (see Chapter 5.2.10).

At any stage in the Quick Examining function, you can return to the basic measure/generate function by pressing the key **□ESC**.

To examine readings saved in the Data Memory, load them first into the Working Memory. Note, that loading always deletes the existing contents of the Working Memory!

5.4 Saving instrument and calibration data to Data Memory

5.4.1 Saving As Found test results

The Working Memory can only hold results from one test (As Found or As Left). Save the contents of the Working Memory to the Data Memory before the next test.

In order to save the As Found test results, press first

□FUNC □STO

The upper display will show

SAVE

The default memory area number on the lower display is the one used in the latest LOAD or SAVE function. It is, however, always without sign. Normally you only need to change the sign of the memory area and accept the saving by keying

□+/- □ENT

If the instrument was not loaded from Data Memory and you haven't saved it earlier, no default memory area number exists and you must enter the area number entirely.

TC305/TC303 refuses to save to a memory area, where another instrument is already saved. If you enter such a number, it requests again with the original default number or empty display.

If you do not want to save to the default memory area, key in the complete memory area number.

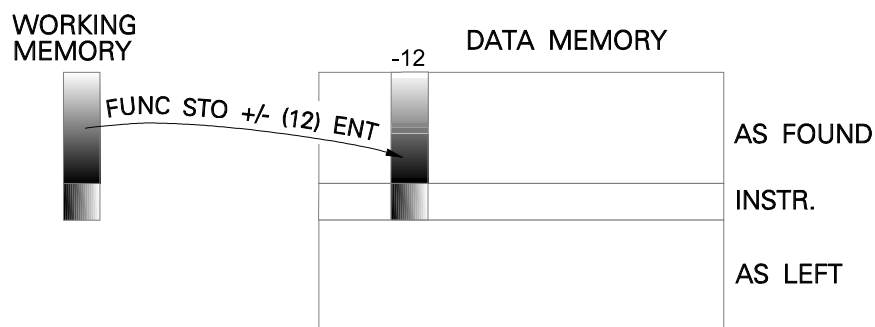

TC305/TC303 asks next for the user code. It can be any string of max. 6 characters. The code must be unique for each user. Use for example your birth day or your initials (see Chapter 7, how to key in alphabetic characters). When the calibrator prompts

USER ?

enter your user code, e.g.

□1 □6 □1 □2 □4 □9 □ENT

If you don't want to use the code, press **□ENT** only.

Each instrument coming from the **QCAL Software** database has a unique identifier - tag number or serial number. If you, however, keyed the instrument data directly into the calibrator, TC305/TC303 asks now for the identifier:

ID ?

The identifier is a string of max. 12 characters. You can use it to identify instruments. When using Beamex **QCAL Software** calibration database, entering of the identifier is not necessary. Enter the identifier or just press ENT to omit it. See Chapter 7, how to key in alphabetic characters.

TC305/TC303 saves the data immediately after you have given all the requested information. If you want to escape without saving, press the key ESC before that.

5.4.2 Saving As Left test results

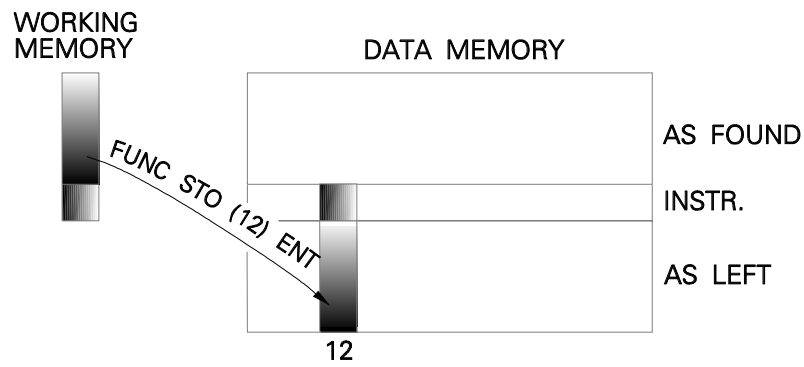

Start the saving by pressing

FUNC STO

The upper display shows

SAVE

The default memory area number on the lower display is the one used in the latest LOAD or SAVE function. It is, however, always without sign. Normally you only need to accept the saving by keying

ENT

If the instrument was not loaded from Data Memory and you haven't saved it earlier, no default memory area number exists and you must enter the area number entirely.

TC305/TC303 refuses to save to a memory area, where another instrument is already saved. If you enter such a number, it requests again with the original default number or empty display.

If you don't want to save to the default memory area, key in the complete memory area number.

TC305/TC303 requests for the user code. Accept the default code (same as in previous save) by pressing

□ENT

TC305/TC303 saves now the data. If you want to escape without saving, press the key

□ESC

before entering the user code.

5.5 Clearing of memory

The Quick Store function automatically cleans old readings from the Working Memory before storing new results. You may, however, sometimes need a separate function for cleaning calibration results from the Working Memory or from a certain memory area in the Data Memory.

Sometimes it is useful to delete all data and calibration results of an instrument. You may even want to delete the entire Data Memory.

All the deletions of instrument data and/or calibration results are collected in the function menu entry

FUNC

<CLEAR> (quick select **□FUNC □0**)

For more details, see Chapter 3.6 in part C of this manual.

6 ENTERING INSTRUMENT DATA FOR QUICK STORE

6.1 General

While working with the Beamex **QCAL Software** calibration database system, manual entering of instrument data is not normally necessary. It is, although, practical in case you want to calibrate an instrument without down loading it from the computer. Manual entering may also be necessary, if you use TC305/TC303 with an other calibration database than Beamex **QCAL Software**.

If the Working Memory contents comes from the **QCAL Software** database, you can't enter instrument data. To be able to enter instrument data, load the default data from a memory area not coming from **QCAL Software**. If such areas are not free, clear one memory area and load one side of it to the Working Memory. Clearing is explained in part C of this manual in Chapter 3.6.

6.2 Temperature transmitters and electrical converters

A) Temperature transmitters

- * Select the instrument function type and input method from the configuration menu (quick select **CONF** **CL**):
TT = temperature transmitter
SIM = sensor simulated by TC305/TC303.

TC305/TC303 automatically selects temperature mode. In case there are no temperature sensor(s) defined for the selected A-section terminals, TC305/TC303 selects the first terminals with defined temperature sensor(s).
- * Turn the MEASURE/GENERATE switch to the position GENERATE.
- * Select the output terminals for sensor simulation (key **SEL**[8]).
- * Select temperature mode by pressing the key **T/EL**[4]
- * Select the temperature sensor type (key **SENSOR**[7]).
- * Select the temperature unit (key **°C/°F**[1]).
- * In case of thermocouple simulation, select the reference junction mode (key **CJ**[0]). If you use manual reference junction mode, check also the CJ-temperature setting (quick select **FUNC** **+/-**).
- * You can set TC305/TC303 temporarily to show the measured electrical quantity instead of temperature (key **T/EL**[4]). The Quick Store function automatically reselects the temperature mode.
- * Enter the instrument input range limits (keys **0%**[.] and **100%**[2]).
- * Select the B-section terminals to be used for instrument output measurement (key **SEL**[9]).
- * Enter the instrument output range limits (keys **0%**[+/-] and **100%**[3]).
- * Select the calibration points (quick select **CONF** **3**, **CONF** **5**, **CONF** **7**, **CONF** **+/-** or **CONF** **.**).
- Select the setpoint delay (quick select **CONF** **6**) according to the instrument under test.
-

B) Electrical converter

- * Select the instrument function type and input method from the configuration menu (quick select **CONF** **CL**):
EEC = electrical converter
GEN = input generated by TC305/TC303.
- * Turn the MEASURE/GENERATE switch to the position GENERATE.
- * Select the output terminals for instrument input generation (key **SEL**[8]).
- * Enter the instrument input range limits (keys **0%**[.] and **100%**[2]).
- * Select the B-section terminals for instrument output measurement (key **SEL**[9]).

- * Enter the instrument output range limits (keys $\square 0\% [+/-]$ and $\square 100\% [3]$).
- * Select the calibration points (quick select $\square \text{CONF } \square 3$, $\square \text{CONF } \square 5$, $\square \text{CONF } \square 7$, $\square \text{CONF } \square +/-$ or $\square \text{CONF } \square .$).
- * Select the setpoint delay (quick select $\square \text{CONF } \square 6$) according to the instrument under test.
- * Select square rooting error calculation, if the instrument under test is a square rooting converter (quick select $\square \text{CONF } \square 4$).

6.3 Indicators and recorders

A) Temperature indicators and recorders

- * Select the instrument function type and input method from the configuration menu (quick select $\square \text{CONF } \square \text{CL}$):
TIR = temperature indicator or recorder
SIM = sensor simulated by TC305/TC303.

TC305/TC303 automatically selects temperature mode. In case there are no temperature sensor(s) defined for the selected A-section terminals, TC305/TC303 selects the first electrical terminals with defined temperature sensor(s).
- * Turn the Measure/Generate switch to the position Generate.
- * Select the output terminals for sensor simulation (key $\square \text{SEL} [8]$).
- * Select temperature mode by pressing the key $\square \text{T/EL} [4]$
- * Select the temperature sensor type (key $\square \text{SENSOR} [7]$).
- * Select the temperature unit (key $\square ^\circ \text{C}/^\circ \text{F} [1]$).
- * In case of thermocouple simulation, select the reference junction mode (key $\square \text{CJ} [0]$). If you use manual reference junction mode, check also the CJ-temperature setting (quick select $\square \text{FUNC } \square +/-$).
- * You can set TC305/TC303 temporarily to show the measured electrical quantity instead of temperature (key $\square \text{T/EL} [4]$). The Quick Store function automatically reselects the temperature mode.
- * Enter the instrument input range limits (keys $\square 0\% [.]$ and $\square 100\% [2]$).
- * Enter the instrument display/scale limits (keys $\square 0\% [+/-]$ and $\square 100\% [3]$).
- * Select the calibration points (quick select $\square \text{CONF } \square 3$, $\square \text{CONF } \square 5$, $\square \text{CONF } \square 7$, $\square \text{CONF } \square +/-$ or $\square \text{CONF } \square .$).

B) Electrical indicators and recorders

- * Select the instrument function type and input method from the configuration menu (quick select CONF CL):
EIR = electrical indicator or recorder
GEN = input generated by TC305/TC303.
- * Turn the MEASURE/GENERATE switch to the position GENERATE.
- * Select the output terminals for input generation (key SEL[8]).
- * Enter the instrument input range limits (keys 0%[.] and 100%[2]).
- * Enter the instrument display/scale limits (keys 0%[+/-] and 100%[3]).
- * Select the calibration points (quick select CONF 3, CONF 5, CONF 7, CONF +/- or CONF .).
- * Select square rooting error calculation, if the instrument under test has square rooting scale (quick select CONF 4).

6.4 Thermometers

- * Select the instrument function type and input method from the configuration menu (quick select CONF CL):
TIR = thermometer (temperature indicator w. integral sensor)
MEA = reference measurement with TC305/TC303.

TC305/TC303 automatically selects temperature mode. In case there are no temperature sensor(s) defined for the selected A-section terminals, TC305/TC303 selects the first electrical terminals with defined temperature sensor(s).
- * Turn the MEASURE/GENERATE switch to the position MEASURE.
- * Select the input terminals for measurement with the reference sensor (key SEL[8]).
- * Select temperature mode by pressing the key T/EL[4]
- * Select the reference temperature sensor type (key SENSOR[7]).
- * Select the temperature unit (key °C/°F[1]).
- * In case of thermocouple measurement, select the reference junction mode (key CJ[0]). If manual reference junction mode is used, check also the CJ-temperature setting (quick select FUNC +/-).
- * You can set TC305/TC303 temporarily to show the measured electrical quantity instead of temperature (key T/EL[4]). The Quick Store function automatically reselects the temperature mode.
- * Enter the instrument input range limits (keys 0%[.] and 100%[2]).
- * Enter the instrument display/scale limits (keys 0%[+/-] and 100%[3]).
- * Select the calibration points (quick select CONF 3, CONF 5, CONF 7, CONF +/- or CONF .).

6.5 Temperature sensors

- * Select the instrument function type and input method from the configuration menu (quick select CONF CL):
TE = temperature sensor
KEY = actual temperature keyed (if necessary) to TC305/TC303.

TC305/TC303 automatically selects temperature mode. In case there are no temperature sensor(s) defined for the selected A-section terminals, TC305/TC303 selects the first electrical terminals with defined temperature sensor(s).
- * Turn the MEASURE/GENERATE switch to the position MEASURE.
- * Select the input terminals for the sensor output measurement (key SEL[8]).
- * Select temperature mode by pressing the key T/EL[4]
- * Select the temperature sensor type (key SENSOR[7]).
- * Select the temperature unit (key °C/°F[1]).
- * In case of thermocouple, select the reference junction mode (key CJ[0]). If you use the manual reference junction mode, check also the CJ-temperature setting (quick select FUNC +/-).
- * You can set TC305/TC303 temporarily to show the measured electrical quantity instead of temperature (key T/EL[4]). The Quick Store function automatically reselects the temperature mode.
- * Enter the sensor measurement range limits (keys 0%[.] and 100%[2]). TC305/TC303 copies the values automatically to the 0%[+/-] and 100%[3] values, too.
- * Select the calibration points (quick select CONF 3, CONF 5, CONF 7, CONF +/- or CONF .).

6.6 Temperature transmitters with sensor

A) Separate temperature measurement or fixed temperature points

- * Select the instrument function type and input method from the configuration menu (quick select CONF CL):
TT = temperature transmitter (with sensor)
KEY = actual temperature keyed (if necessary) to TC305/TC303.

TC305/TC303 automatically selects temperature mode. In case there are no temperature sensor(s) defined for the selected A-section terminals, TC305/TC303 selects the first electrical terminals with defined temperature sensor(s).

The selections SEL[8], SENSOR[7], CJ[0] and the position of the MEASURE/GENERATE-switch have no function in this case.

- * Select the temperature unit (key °C/°F[1]).
- * Enter the transmitter measurement range limits (keys 0%[.] and 100%[2]).
- * Select the B-section terminals for instrument output measurement (key SEL[9]).
- * Enter the instrument output range limits (keys 0%[+/-] and 100%[3]).
- * Select the calibration points (quick select CONF 3, CONF 5, CONF 7, CONF +/- or CONF .).

B) Reference measurement with TC305/TC303

- * Select the instrument function type and input method from the configuration menu (quick select CONF CL):
TT = temperature transmitter (with sensor)
MEA = reference measurement with TC305/TC303.

TC305/TC303 automatically selects temperature mode. In case there are no temperature sensor(s) defined for the selected A-section terminals, TC305/TC303 selects the first electrical terminals with defined temperature sensor(s).
- * Turn the MEASURE/GENERATE switch to the position MEASURE.
- * Select the input terminals for the reference sensor measurement (key SEL[8]).
- * Select temperature mode by pressing the key T/EL[4]
- * Select the reference sensor type (key SENSOR[7]).
- * Select the temperature unit (key °C/°F[1]).
- * If the reference sensor is a thermocouple, select the reference junction mode (key CJ[0]). If you use the manual reference junction mode, check also the CJ-temperature setting (quick select FUNC +/-).
- * You can set TC305/TC303 temporarily to show the measured electrical quantity instead of temperature (key T/EL[4]). The Quick Store function automatically reselects the temperature mode.
- * Enter the transmitter measurement range limits (keys 0%[,] and 100%[2]).
- * Select the B-section terminals for instrument output measurement (key SEL[9]).
- * Enter the instrument output range limits (keys 0%[+/-] and 100%[3]).
- * Select the calibration points (quick select CONF 3, CONF 5, CONF 7, CONF +/- or CONF .).

6.7 Electrical limit switches and temperature limit switches (thermostats)

A) Electrical limit switches

- * Select the instrument function type and input method from the configuration menu, quick select CONF CL (Switch calibration option required):
ESNO/ESNC = NO/NC electrical limit switch
GEN = input generated by TC305/TC303.
TESTS = number of required test repetitions (max. 10).

TC305/TC303 automatically selects switch state detection in the B-section.
- * Turn the MEASURE/GENERATE switch to the position GENERATE.
- * Select the output terminals for instrument input generation (key SEL[8]).
- * Enter the required actuation and deactuation points. The actuation point is the point, where the switch state changes from the normal state to the actuated state. At the deactuation point it returns back to the normal state. Use the key 0%[,] for actuation and 100%[2] for deactuation point definition. Setting is similar to the setting of the 0% and 100% values, but TC305/TC303 uses the prompts ACT and DEACT.
- * Enter the limits of the allowed range, where TC305/TC303 can scan for the actuation and deactuation points. Use the key 0%[+/-] for low scanning limit (prompt SCAN.LO) and the key 100%[3] for the high scanning limit (prompt SCAN.HI).
- * Select the setpoint delay (quick select CONF 6) according to the instrument under test.

B) Temperature limit switches (thermostats)

- * Select the instrument function type and input method from the configuration menu, quick select CONF CL (Switch calibration option required):
TSNO/TSNC = NO/NC temperature limit switch (thermostat)
SIM = sensor simulated by TC305/TC303.
TESTS = number of required test repetitions (max. 10).

TC305/TC303 automatically selects switch state detection in the B-section. It also selects temperature mode. In case there are no temperature sensor(s) defined for the selected A-section terminals, TC305/TC303 selects the first electrical terminals with defined temperature sensor(s).
- * Turn the MEASURE/GENERATE switch to the position GENERATE.
- * Select the output terminals for sensor simulation (key SEL[8]).
- * Select temperature mode by pressing the key T/EL[4]
- * Select the temperature sensor type (key SENSOR[7]).
- * Select the temperature unit (key °C/°F[1]).
- * In case of thermocouple simulation, select the reference junction mode (key CJ[0]). If you use the manual reference junction mode, check also the CJ-temperature setting (quick select FUNC +/-).
- * You can set TC305/TC303 temporarily to show the measured electrical quantity instead of temperature (key T/EL[4]). The Quick Store function automatically reselects the temperature mode.
- * Enter the required actuation and deactuation points. The actuation point is the point, where the switch state changes from the normal state to the actuated state. At the deactuation point it returns back to the normal state. Use the key 0%[,] for actuation and 100%[2] for deactuation point definition. Setting is similar to the setting of the 0% and 100% values, but TC305/TC303 uses the prompts ACT and DEACT.
- * Enter the limits of the allowed range, where TC305/TC303 can scan for the actuation and deactuation points. Use the key 0%[+/-] for low scanning limit (prompt SCAN.LO) and the key 100%[3] for the high scanning limit (prompt SCAN.HI).
- * Select the setpoint delay (quick select CONF 6) according to the instrument under test.

6.8 Temperature limit switches (thermostats) with sensor

- * Select the instrument function type and input method from the configuration menu, quick select CONF CL (Switch calibration option required):

TSNO/TSNC = NO/NC temperature limit switch (thermostat)

MEA = reference measurement with TC305/TC303.

TESTS = number of required test repetitions (max. 10).

TC305/TC303 automatically selects switch state detection in the B-section. It also selects temperature mode. In case there are no temperature sensor(s) defined for the selected A-section terminals, TC305/TC303 selects the first electrical terminals with defined temperature sensor(s).

- * Turn the MEASURE/GENERATE switch to the position MEASURE.
- * Select the input terminals for the reference sensor measurement (key SEL[8]).
- * Select temperature mode by pressing the key T/EL[4]
- * Select the reference sensor type (key SENSOR[7]).
- * Select the temperature unit (key °C/°F[1]).
- * If the reference sensor is a thermocouple, select the reference junction mode (key CJ[0]). If you use the manual reference junction mode, check also the CJ-temperature setting (quick select FUNC +/-).
- * You can set TC305/TC303 temporarily to show the measured electrical quantity instead of temperature (key T/EL[4]). The Quick Store function automatically reselects the temperature mode.
- * Enter the required actuation and deactuation points. The actuation point is the point, where the switch state changes from the normal state to the actuated state. At the deactuation point it returns back to the normal state. Use the key 0%[,] for actuation and 100%[2] for deactuation point definition. Setting is similar to the setting of the 0% and 100% values, but TC305/TC303 uses the prompts ACT and DEACT.

6.9 TC305/TC303 measurement and generation ranges

A) Section A electrical measurement ranges

- * Select the instrument function type and input method from the configuration menu (quick select CONF CL):
ERC = calibrator electrical range
EXT = measurement on the A-section.
(Measurement signal generated externally.)
- * Turn the MEASURE/GENERATE switch to the position MEASURE.
- * Select the measurement terminals (key SEL[8]).
- * Enter the limits of the range to be tested (keys 0%[.] and 100%[2]).
TC305/TC303 copies the values automatically to the 0%[+/-] and 100%[3] values, too.
- * Select the calibration points (quick select CONF 3, CONF 5, CONF 7, CONF +/- or CONF .).

B) Section A temperature measurement ranges

- * Select the instrument function type and input method from the configuration menu (quick select CONF CL):
TRC = calibrator temperature range
EXT = measurement on the A-section.
(Measurement signal generated externally.)

TC305/TC303 automatically selects temperature mode. In case there are no temperature sensor(s) defined for the selected A-section terminals, TC305/TC303 selects the first electrical terminals with defined temperature sensor(s).
- * Turn the MEASURE/GENERATE switch to the position MEASURE.
- * Select the measurement terminals (key SEL[8]).
- * Select temperature mode by pressing the key T/EL[4]
- * Select the temperature sensor type (key SENSOR[7]).
- * Select the temperature unit (key °C/°F[1]).
- * In case of thermocouple measurement, select the reference junction mode (key CJ[0]). If you use the manual reference junction mode, check also the CJ-temperature setting (quick select FUNC +/-).
- * You can set TC305/TC303 temporarily to show the measured electrical quantity instead of temperature (key T/EL[4]). The Quick Store function automatically reselects the temperature mode.
- * Enter the measurement range limits (keys 0%[.] and 100%[2]).
TC305/TC303 copies the values automatically to the 0%[+/-] and 100%[3] values, too.
- * Select the calibration points (quick select CONF 3, CONF 5, CONF 7, CONF +/- or CONF .).

C) Section A electrical generation ranges

- * Select the instrument function type and input method from the configuration menu (quick select CONF CL):
ERC = calibrator electrical range
GEN = generation on the A-section.
- * Turn the MEASURE/GENERATE switch to the position GENERATE.
- * Select the output terminals for generation (key SEL[8]).
- * Enter the generation range limits (keys 0%[.] and 100%[2]).
TC305/TC303 copies the values automatically to the 0%[+/-] and 100%[3] values, too.
- * Select the calibration points (quick select CONF 3, CONF 5, CONF 7, CONF +/- or CONF .).

D) Section A temperature simulation ranges

- * Select the instrument function type and input method from the configuration menu (quick select CONF CL):
TRC = calibrator temperature range
SIM = simulation on the A-section.

TC305/TC303 automatically selects temperature mode. In case there are no temperature sensor(s) defined for the selected A-section terminals, TC305/TC303 selects the first terminals with defined temperature sensor(s).
- * Turn the MEASURE/GENERATE switch to the position GENERATE.
- * Select the output terminals for sensor simulation (key SEL[8]).
- * Select temperature mode by pressing the key T/EL[4]
- * Select the temperature sensor type (key SENSOR[7]).
- * Select the temperature unit (key °C/°F[1]).
- * In case of thermocouple simulation, select the reference junction mode (key CJ[0]). If manual reference junction mode is used, check also the CJ-temperature setting (quick select FUNC +/-).
- * You can set TC305/TC303 temporarily to show the measured electrical quantity instead of temperature (key T/EL[4]). The Quick Store function automatically reselects the temperature mode.
- * Enter the simulation range limits (keys 0%[.] and 100%[2]).
TC305/TC303 copies the values automatically to the 0%[+/-] and 100%[3] values, too.
- * Select the calibration points (quick select CONF 3, CONF 5, CONF 7, CONF +/- or CONF .).

E) Section B measurement ranges

- * Select the instrument function type and input method from the configuration menu (quick select **CONF** **CL**):
ERC = calibrator electrical range
- = measurement on the B-section.
(measurement signal generated externally)

- * Select the B-section terminals for measurement (key **SEL**[9]).
- * Enter the measurement range limits (keys **0%**[+/-] and **100%**[3]).
TC305/TC303 copies the values automatically to the **0%**[.] and **100%**[2] values, too.
- * Select the calibration points (quick select **CONF** **3**, **CONF** **5**, **CONF** **7**, **CONF** **+/-** or **CONF** **.**).

7 ENTERING AND DISPLAYING ALPHANUMERIC STRINGS

The displays of the TC305/TC303 calibrator are optimized for numeric information. In certain situations, however, it shows also text messages. Even entering of text is possible in some cases.

Entering always starts in numeric mode, i.e. the keys 0 ... 9, and +/- are active. Pressing decimal point key actually gives colon (:). If you want to enter alphabet characters, pick up the right key first. The character is marked near to the upper or lower right corner of the key.

Use the up-key to select the upper/lower alphabet. TC305/TC303 uses arrows on the right side of the displays to show the selection. Arrows on the upper or lower display show whether the upper or lower alphabet mode is selected. After selection of the right alphabet mode, press the appropriate key to get the character on the display. Single pressing of the up-key swaps from one alphabet mode to the other, pressing twice returns back to the numeric mode. TC305/TC303 always sends the entered letters to the computer as capital letters.

While entering text, the flashing cursor shows the position of the next character. If the reserved space for the character is full, the cursor disappears and the only active keys are ENT, ESC, CL and <--.

The following table shows the figures, used to represent alphanumeric characters on TC305/TC303 displays. If the text comes from the computer and contains characters that TC305/TC303 cannot show, it shows three stacked lines.

0	1	2	3	4	5	6	7	8	9	A	B	C	D	E
F	G	H	I	J	K	L	M	N	O	P	Q	R	S	T
U	V	W	X	Y	Z	[]	^	_	-	/	=		