



ROHDE & SCHWARZ

Test and Measurement
Division

Manual

Average Power Sensor

R&S[®] NRP-Z11

10 MHz to 8 GHz / 200 pW to 200 mW

1138.3004.02

R&S[®] NRP-Z21

10 MHz to 18 GHz / 200 pW to 200 mW

1137.6000.02

Printed in the Federal
Republic of Germany

Dear Customer,

R&S® is a registered trademark of Rohde & Schwarz GmbH & Co. KG.
Trade names are trademarks of the owners.

1137.7406.32-02-

2

Operation of Power Sensor R&S NRP-Z11 from R&S NRP base unit

The power sensor shipped with this manual has firmware revision **02.00** or higher. For operation from an R&S NRP base unit, all software components within the base unit must also be of revision **02.00** or higher.

Revision numbers for the software components installed in the base unit can be displayed under menu item 'System Info', lines 'Main Program', 'Bootloader' and 'Keybd. Ctrl.'. The 'System Info' can be found in the 'File' menu for revision numbers lower than 02.00 and in the 'System' menu otherwise.

Tabbed Divider Overview

Data Sheet

Safety Instructions
Certificate of Quality
EU Certificate of Conformity
List of R&S Representatives

Tabbed Divider

- | | |
|----------|---|
| 1 | Chapter 1: Putting into Operation |
| 2 | Chapter 2: Virtual Power Meter |
| 3 | Chapter 3: Operation |
| 4 | Chapter 4: for future extensions |
| 5 | Chapter 5: Remote Control – Basics |
| 6 | Chapter 6: Remote Control – Commands |
| 7 | Chapter 7: for future extensions |
| 8 | Service Instructions |



Before putting the product into operation for the first time, make sure to read the following



Safety Instructions

Rohde & Schwarz makes every effort to keep the safety standard of its products up to date and to offer its customers the highest possible degree of safety. Our products and the auxiliary equipment required for them are designed and tested in accordance with the relevant safety standards. Compliance with these standards is continuously monitored by our quality assurance system. This product has been designed and tested in accordance with the EC Certificate of Conformity and has left the manufacturer's plant in a condition fully complying with safety standards. To maintain this condition and to ensure safe operation, observe all instructions and warnings provided in this manual. If you have any questions regarding these safety instructions, Rohde & Schwarz will be happy to answer them.

Furthermore, it is your responsibility to use the product in an appropriate manner. This product is designed for use solely in industrial and laboratory environments or in the field and must not be used in any way that may cause personal injury or property damage. You are responsible if the product is used for an intention other than its designated purpose or in disregard of the manufacturer's instructions. The manufacturer shall assume no responsibility for such use of the product.

The product is used for its designated purpose if it is used in accordance with its operating manual and within its performance limits (see data sheet, documentation, the following safety instructions). Using the products requires technical skills and knowledge of English. It is therefore essential that the products be used exclusively by skilled and specialized staff or thoroughly trained personnel with the required skills. If personal safety gear is required for using Rohde & Schwarz products, this will be indicated at the appropriate place in the product documentation.

Symbols and safety labels

Observe operating instructions	Weight indication for units >18 kg	Danger of electric shock	Warning! Hot surface	PE terminal	Ground	Ground terminal	Attention! Electrostatic sensitive devices

Supply voltage ON/OFF	Standby indication	Direct current (DC)	Alternating current (AC)	Direct/alternating current (DC/AC)	Device fully protected by double/reinforced insulation

Safety Instructions

Observing the safety instructions will help prevent personal injury or damage of any kind caused by dangerous situations. Therefore, carefully read through and adhere to the following safety instructions before putting the product into operation. It is also absolutely essential to observe the additional safety instructions on personal safety that appear in other parts of the documentation. In these safety instructions, the word "product" refers to all merchandise sold and distributed by Rohde & Schwarz, including instruments, systems and all accessories.

Tags and their meaning

DANGER	This tag indicates a safety hazard with a high potential of risk for the user that can result in death or serious injuries.
WARNING	This tag indicates a safety hazard with a medium potential of risk for the user that can result in death or serious injuries.
CAUTION	This tag indicates a safety hazard with a low potential of risk for the user that can result in slight or minor injuries.
ATTENTION	This tag indicates the possibility of incorrect use that can cause damage to the product.
NOTE	This tag indicates a situation where the user should pay special attention to operating the product but which does not lead to damage.

These tags are in accordance with the standard definition for civil applications in the European Economic Area. Definitions that deviate from the standard definition may also exist. It is therefore essential to make sure that the tags described here are always used only in connection with the associated documentation and the associated product. The use of tags in connection with unassociated products or unassociated documentation can result in misinterpretations and thus contribute to personal injury or material damage.

Basic safety instructions

1. The product may be operated only under the operating conditions and in the positions specified by the manufacturer. Its ventilation must not be obstructed during operation. Unless otherwise specified, the following requirements apply to Rohde & Schwarz products:
prescribed operating position is always with the housing floor facing down, IP protection 2X, pollution severity 2, overvoltage category 2, use only in enclosed spaces, max. operation altitude max. 2000 m. Unless specified otherwise in the data sheet, a tolerance of $\pm 10\%$ shall apply to the nominal voltage and of $\pm 5\%$ to the nominal frequency.
2. Applicable local or national safety regulations and rules for the prevention of accidents must be observed in all work performed. The product may be opened only by authorized, specially trained personnel. Prior to performing any work on the product or opening the product, the product must be disconnected from the supply network. Any adjustments, replacements of parts, maintenance or repair must be carried out only by technical personnel authorized by Rohde & Schwarz. Only original parts may be used for replacing parts relevant to safety (e.g. power switches, power transformers, fuses). A safety test must always be performed after parts relevant to safety have been replaced (visual inspection, PE conductor test, insulation resistance measurement, leakage current measurement, functional test).
3. As with all industrially manufactured goods, the use of substances that induce an allergic reaction (allergens, e.g. nickel) such as aluminum cannot be generally excluded. If you develop an allergic reaction (such as a skin rash, frequent sneezing, red eyes or respiratory difficulties), consult a physician immediately to determine the cause.

Safety Instructions

4. If products/components are mechanically and/or thermally processed in a manner that goes beyond their intended use, hazardous substances (heavy-metal dust such as lead, beryllium, nickel) may be released. For this reason, the product may only be disassembled, e.g. for disposal purposes, by specially trained personnel. Improper disassembly may be hazardous to your health. National waste disposal regulations must be observed.
5. If handling the product yields hazardous substances or fuels that must be disposed of in a special way, e.g. coolants or engine oils that must be replenished regularly, the safety instructions of the manufacturer of the hazardous substances or fuels and the applicable regional waste disposal regulations must be observed. Also observe the relevant safety instructions in the product documentation.
6. Depending on the function, certain products such as RF radio equipment can produce an elevated level of electromagnetic radiation. Considering that unborn life requires increased protection, pregnant women should be protected by appropriate measures. Persons with pacemakers may also be endangered by electromagnetic radiation. The employer is required to assess workplaces where there is a special risk of exposure to radiation and, if necessary, take measures to avert the danger.
7. Operating the products requires special training and intense concentration. Make certain that persons who use the products are physically, mentally and emotionally fit enough to handle operating the products; otherwise injuries or material damage may occur. It is the responsibility of the employer to select suitable personnel for operating the products.
8. Prior to switching on the product, it must be ensured that the nominal voltage setting on the product matches the nominal voltage of the AC supply network. If a different voltage is to be set, the power fuse of the product may have to be changed accordingly.
9. In the case of products of safety class I with movable power cord and connector, operation is permitted only on sockets with earthing contact and protective earth connection.
10. Intentionally breaking the protective earth connection either in the feed line or in the product itself is not permitted. Doing so can result in the danger of an electric shock from the product. If extension cords or connector strips are implemented, they must be checked on a regular basis to ensure that they are safe to use.
11. If the product has no power switch for disconnection from the AC supply, the plug of the connecting cable is regarded as the disconnecting device. In such cases, it must be ensured that the power plug is easily reachable and accessible at all times (length of connecting cable approx. 2 m). Functional or electronic switches are not suitable for providing disconnection from the AC supply. If products without power switches are integrated in racks or systems, a disconnecting device must be provided at the system level.
12. Never use the product if the power cable is damaged. By taking appropriate safety measures and carefully laying the power cable, ensure that the cable cannot be damaged and that no one can be hurt by e.g. tripping over the cable or suffering an electric shock.
13. The product may be operated only from TN/TT supply networks fused with max. 16 A.
14. Do not insert the plug into sockets that are dusty or dirty. Insert the plug firmly and all the way into the socket. Otherwise this can result in sparks, fire and/or injuries.
15. Do not overload any sockets, extension cords or connector strips; doing so can cause fire or electric shocks.
16. For measurements in circuits with voltages $V_{rms} > 30 V$, suitable measures (e.g. appropriate measuring equipment, fusing, current limiting, electrical separation, insulation) should be taken to avoid any hazards.
17. Ensure that the connections with information technology equipment comply with IEC 950/EN 60950.
18. Never remove the cover or part of the housing while you are operating the product. This will expose circuits and components and can lead to injuries, fire or damage to the product.

Safety Instructions

19. If a product is to be permanently installed, the connection between the PE terminal on site and the product's PE conductor must be made first before any other connection is made. The product may be installed and connected only by a skilled electrician.
20. For permanently installed equipment without built-in fuses, circuit breakers or similar protective devices, the supply circuit must be fused in such a way that suitable protection is provided for users and products.
21. Do not insert any objects into the openings in the housing that are not designed for this purpose. Never pour any liquids onto or into the housing. This can cause short circuits inside the product and/or electric shocks, fire or injuries.
22. Use suitable overvoltage protection to ensure that no overvoltage (such as that caused by a thunderstorm) can reach the product. Otherwise the operating personnel will be endangered by electric shocks.
23. Rohde & Schwarz products are not protected against penetration of water, unless otherwise specified (see also safety instruction 1.). If this is not taken into account, there exists the danger of electric shock or damage to the product, which can also lead to personal injury.
24. Never use the product under conditions in which condensation has formed or can form in or on the product, e.g. if the product was moved from a cold to a warm environment.
25. Do not close any slots or openings on the product, since they are necessary for ventilation and prevent the product from overheating. Do not place the product on soft surfaces such as sofas or rugs or inside a closed housing, unless this is well ventilated.
26. Do not place the product on heat-generating devices such as radiators or fan heaters. The temperature of the environment must not exceed the maximum temperature specified in the data sheet.
27. Batteries and storage batteries must not be exposed to high temperatures or fire. Keep batteries and storage batteries away from children. If batteries or storage batteries are improperly replaced, this can cause an explosion (warning: lithium cells). Replace the battery or storage battery only with the matching Rohde & Schwarz type (see spare parts list). Batteries and storage batteries are hazardous waste. Dispose of them only in specially marked containers. Observe local regulations regarding waste disposal. Do not short-circuit batteries or storage batteries.
28. Please be aware that in the event of a fire, toxic substances (gases, liquids etc.) that may be hazardous to your health may escape from the product.
29. Please be aware of the weight of the product. Be careful when moving it; otherwise you may injure your back or other parts of your body.
30. Do not place the product on surfaces, vehicles, cabinets or tables that for reasons of weight or stability are unsuitable for this purpose. Always follow the manufacturer's installation instructions when installing the product and fastening it to objects or structures (e.g. walls and shelves).
31. Handles on the products are designed exclusively for personnel to hold or carry the product. It is therefore not permissible to use handles for fastening the product to or on means of transport such as cranes, fork lifts, wagons, etc. The user is responsible for securely fastening the products to or on the means of transport and for observing the safety regulations of the manufacturer of the means of transport. Noncompliance can result in personal injury or material damage.
32. If you use the product in a vehicle, it is the sole responsibility of the driver to drive the vehicle safely. Adequately secure the product in the vehicle to prevent injuries or other damage in the event of an accident. Never use the product in a moving vehicle if doing so could distract the driver of the vehicle. The driver is always responsible for the safety of the vehicle; the manufacturer assumes no responsibility for accidents or collisions.
33. If a laser product (e.g. a CD/DVD drive) is integrated in a Rohde & Schwarz product, do not use any other settings or functions than those described in the documentation. Otherwise this may be hazardous to your health, since the laser beam can cause irreversible damage to your eyes. Never try to take such products apart, and never look into the laser beam.



Por favor lea imprescindiblemente antes de la primera puesta en funcionamiento las siguientes informaciones de seguridad



Informaciones de seguridad

Es el principio de Rohde & Schwarz de tener a sus productos siempre al día con los estándares de seguridad y de ofrecer a sus clientes el máximo grado de seguridad. Nuestros productos y todos los equipos adicionales son siempre fabricados y examinados según las normas de seguridad vigentes. Nuestra sección de gestión de la seguridad de calidad controla constantemente que sean cumplidas estas normas. Este producto ha sido fabricado y examinado según el comprobante de conformidad adjunto según las normas de la CE y ha salido de nuestra planta en estado impecable según los estándares técnicos de seguridad. Para poder preservar este estado y garantizar un funcionamiento libre de peligros, deberá el usuario atenerse a todas las informaciones, informaciones de seguridad y notas de alerta. Rohde&Schwarz está siempre a su disposición en caso de que tengan preguntas referentes a estas informaciones de seguridad.

Además queda en la responsabilidad del usuario utilizar el producto en la forma debida. Este producto solamente fue elaborado para ser utilizado en la industria y el laboratorio o para fines de campo y de ninguna manera deberá ser utilizado de modo que alguna persona/cosa pueda ser dañada. El uso del producto fuera de sus fines definidos o despreciando las informaciones de seguridad del fabricante queda en la responsabilidad del usuario. El fabricante no se hace en ninguna forma responsable de consecuencias a causa del maluso del producto.

Se parte del uso correcto del producto para los fines definidos si el producto es utilizado dentro de las instrucciones del correspondiente manual del uso y dentro del margen de rendimiento definido (ver hoja de datos, documentación, informaciones de seguridad que siguen). El uso de los productos hace necesarios conocimientos profundos y el conocimiento del idioma inglés. Por eso se deberá tener en cuenta de exclusivamente autorizar para el uso de los productos a personas péritas o debidamente minuciosamente instruidas con los conocimientos citados. Si fuera necesaria indumentaria de seguridad para el uso de productos de R&S, encontrará la información debida en la documentación del producto en el capítulo correspondiente.

Símbolos y definiciones de seguridad

Ver manual de instrucciones del uso	Informaciones para maquinaria con un peso de > 18kg	Peligro de golpe de corriente	¡Advertencia! Superficie caliente	Conexión a conductor protector	Conexión a tierra	Conexión a masa conductora	¡Cuidado! Elementos de construcción con peligro de carga electrostática

potencia EN MARCHA/PARADA	Indicación Stand-by	Corriente continua DC	Corriente alterna AC	Corriente continua/alterna DC/AC	El aparato está protegido en su totalidad por un aislamiento de doble refuerzo

Informaciones de seguridad

Tener en cuenta las informaciones de seguridad sirve para tratar de evitar daños y peligros de toda clase. Es necesario de que se lean las siguientes informaciones de seguridad concienzudamente y se tengan en cuenta debidamente antes de la puesta en funcionamiento del producto. También deberán ser tenidas en cuenta las informaciones para la protección de personas que encontrarán en otro capítulo de esta documentación y que también son obligatorias de seguir. En las informaciones de seguridad actuales hemos juntado todos los objetos vendidos por Rohde&Schwarz bajo la denominación de „producto“, entre ellos también aparatos, instalaciones así como toda clase de accesorios.

Palabras de señal y su significado

PELIGRO	Indica un punto de peligro con gran potencial de riesgo para el usuario. Punto de peligro que puede llevar hasta la muerte o graves heridas.
ADVERTENCIA	Indica un punto de peligro con un potencial de riesgo mediano para el usuario. Punto de peligro que puede llevar hasta la muerte o graves heridas .
ATENCIÓN	Indica un punto de peligro con un potencial de riesgo pequeño para el usuario. Punto de peligro que puede llevar hasta heridas leves o pequeñas
CUIDADO	Indica la posibilidad de utilizar mal el producto y a consecuencia dañarlo.
INFORMACIÓN	Indica una situación en la que deberían seguirse las instrucciones en el uso del producto, pero que no consecuentemente deben de llevar a un daño del mismo.

Las palabras de señal corresponden a la definición habitual para aplicaciones civiles en el ámbito de la comunidad económica europea. Pueden existir definiciones diferentes a esta definición. Por eso se debiera tener en cuenta que las palabras de señal aquí descritas sean utilizadas siempre solamente en combinación con la correspondiente documentación y solamente en combinación con el producto correspondiente. La utilización de las palabras de señal en combinación con productos o documentaciones que no les correspondan puede llevar a malinterpretaciones y tener por consecuencia daños en personas u objetos.

Informaciones de seguridad elementales

1. El producto solamente debe ser utilizado según lo indicado por el fabricante referente a la situación y posición de funcionamiento sin que se obstruya la ventilación. Si no se convino de otra manera, es para los productos R&S válido lo que sigue: como posición de funcionamiento se define principalmente la posición con el suelo de la caja para abajo , modo de protección IP 2X, grado de suciedad 2, categoría de sobrecarga eléctrica 2, utilizar solamente en estancias interiores, utilización hasta 2000 m sobre el nivel del mar.
A menos que se especifique otra cosa en la hoja de datos, se aplicará una tolerancia de $\pm 10\%$ sobre el voltaje nominal y de $\pm 5\%$ sobre la frecuencia nominal.
2. En todos los trabajos deberán ser tenidas en cuenta las normas locales de seguridad de trabajo y de prevención de accidentes. El producto solamente debe de ser abierto por personal périto autorizado. Antes de efectuar trabajos en el producto o abrirlo deberá este ser desconectado de la corriente. El ajuste, el cambio de partes, la manutención y la reparación deberán ser solamente efectuadas por electricistas autorizados por R&S. Si se reponen partes con importancia para los aspectos de seguridad (por ejemplo el enchufe, los transformadores o los fusibles), solamente podrán ser sustituidos por partes originales. Despues de cada recambio de partes elementales para la seguridad deberá ser efectuado un control de

Informaciones de seguridad

- seguridad (control a primera vista, control de conductor protector, medición de resistencia de aislamiento, medición de medición de la corriente conductora, control de funcionamiento).
3. Como en todo producto de fabricación industrial no puede ser excluido en general de que se produzcan al usarlo elementos que puedan generar alergias, los llamados elementos alergénicos (por ejemplo el níquel). Si se produjeran en el trato con productos R&S reacciones alérgicas, como por ejemplo urticaria, estornudos frecuentes, irritación de la conjuntiva o dificultades al respirar, se deberá consultar inmediatamente a un médico para averiguar los motivos de estas reacciones.
 4. Si productos / elementos de construcción son tratados fuera del funcionamiento definido de forma mecánica o térmica, pueden generarse elementos peligrosos (polvos de sustancia de metales pesados como por ejemplo plomo, berilio, níquel). La partición elemental del producto, como por ejemplo sucede en el tratamiento de materias residuales, debe de ser efectuada solamente por personal especializado para estos tratamientos. La partición elemental efectuada inadecuadamente puede generar daños para la salud. Se deben tener en cuenta las directivas nacionales referentes al tratamiento de materias residuales.
 5. En el caso de que se produjeran agentes de peligro o combustibles en la aplicación del producto que debieran de ser transferidos a un tratamiento de materias residuales, como por ejemplo agentes refrigerantes que deben ser repuestos en periodos definidos, o aceites para motores, deberán ser tenidas en cuenta las prescripciones de seguridad del fabricante de estos agentes de peligro o combustibles y las regulaciones regionales para el tratamiento de materias residuales. Cuiden también de tener en cuenta en caso dado las prescripciones de seguridad especiales en la descripción del producto.
 6. Ciertos productos, como por ejemplo las instalaciones de radiación HF, pueden a causa de su función natural, emitir una radiación electromagnética aumentada. En vista a la protección de la vida en desarrollo deberían ser protegidas personas embarazadas debidamente. También las personas con un bypass pueden correr peligro a causa de la radiación electromagnética. El empresario está comprometido a valorar y señalar áreas de trabajo en las que se corra un riesgo de exposición a radiaciones aumentadas de riesgo aumentado para evitar riesgos.
 7. La utilización de los productos requiere instrucciones especiales y una alta concentración en el manejo. Debe de ponerse por seguro de que las personas que manejen los productos estén a la altura de los requerimientos necesarios referente a sus aptitudes físicas, psíquicas y emocionales, ya que de otra manera no se pueden excluir lesiones o daños de objetos. El empresario lleva la responsabilidad de seleccionar el personal usuario apto para el manejo de los productos.
 8. Antes de la puesta en marcha del producto se deberá tener por seguro de que la tensión preseleccionada en el producto equivalga a la del la red de distribución. Si es necesario cambiar la preselección de la tensión también se deberán en caso dabo cambiar los fusibles correspondientes del producto.
 9. Productos de la clase de seguridad I con alimentación móvil y enchufe individual de producto solamente deberán ser conectados para el funcionamiento a tomas de corriente de contacto de seguridad y con conductor protector conectado.
 10. Queda prohibida toda clase de interrupción intencionada del conductor protector, tanto en la toma de corriente como en el mismo producto ya que puede tener como consecuencia el peligro de golpe de corriente por el producto. Si se utilizaran cables o enchufes de extensión se deberá poner al seguro, que es controlado su estado técnico de seguridad.
 11. Si el producto no está equipado con un interruptor para desconectarlo de la red, se deberá considerar el enchufe del cable de distribución como interruptor. En estos casos deberá asegurar de que el enchufe sea de fácil acceso y nabejo (medida del cable de distribución aproximadamente 2 m). Los interruptores de función o electrónicos no son aptos para el corte de la red eléctrica. Si los productos sin interruptor están integrados en construcciones o instalaciones, se deberá instalar el interruptor al nivel de la instalación.

Informaciones de seguridad

12. No utilice nunca el producto si está dañado el cable eléctrico. Asegure a través de las medidas de protección y de instalación adecuadas de que el cable de eléctrico no pueda ser dañado o de que nadie pueda ser dañado por él, por ejemplo al tropezar o por un golpe de corriente.
13. Solamente está permitido el funcionamiento en redes de distribución TN/TT aseguradas con fusibles de como máximo 16 A.
14. Nunca conecte el enchufe en tomas de corriente sucias o llenas de polvo. Introduzca el enchufe por completo y fuertemente en la toma de corriente. Si no tiene en consideración estas indicaciones se arriesga a que se originen chispas, fuego y/o heridas.
15. No sobrecargue las tomas de corriente, los cables de extensión o los enchufes de extensión ya que esto pudiera causar fuego o golpes de corriente.
16. En las mediciones en circuitos de corriente con una tensión de entrada de $U_{eff} > 30 \text{ V}$ se deberá tomar las precauciones debidas para impedir cualquier peligro (por ejemplo medios de medición adecuados, seguros, limitación de tensión, corte protector, aislamiento etc.).
17. En caso de conexión con aparatos de la técnica informática se deberá tener en cuenta que estos cumplan los requisitos de la EC950/EN60950.
18. Nunca abra la tapa o parte de ella si el producto está en funcionamiento. Esto pone a descubierto los cables y componentes eléctricos y puede causar heridas, fuego o daños en el producto.
19. Si un producto es instalado fijamente en un lugar, se deberá primero conectar el conductor protector fijo con el conductor protector del aparato antes de hacer cualquier otra conexión. La instalación y la conexión deberán ser efectuadas por un electricista especializado.
20. En caso de que los productos que son instalados fijamente en un lugar sean sin protector implementado, autointerruptor o similares objetos de protección, deberá la toma de corriente estar protegida de manera que los productos o los usuarios estén suficientemente protegidos.
21. Por favor, no introduzca ningún objeto que no esté destinado a ello en los orificios de la caja del aparato. No vierta nunca ninguna clase de líquidos sobre o en la caja. Esto puede producir corto circuitos en el producto y/o puede causar golpes de corriente, fuego o heridas.
22. Asegúrese con la protección adecuada de que no pueda originarse en el producto una sobrecarga por ejemplo a causa de una tormenta. Si no se verá el personal que lo utilice expuesto al peligro de un golpe de corriente.
23. Los productos R&S no están protegidos contra el agua si no es que exista otra indicación, ver también punto 1. Si no se tiene en cuenta esto se arriesga el peligro de golpe de corriente o de daños en el producto lo cual también puede llevar al peligro de personas.
24. No utilice el producto bajo condiciones en las que pueda producirse y se hayan producido líquidos de condensación en o dentro del producto como por ejemplo cuando se desplaza el producto de un lugar frío a un lugar caliente.
25. Por favor no cierre ninguna ranura u orificio del producto, ya que estas son necesarias para la ventilación e impiden que el producto se caliente demasiado. No pongan el producto encima de materiales blandos como por ejemplo sofás o alfombras o dentro de una caja cerrada, si esta no está suficientemente ventilada.
26. No ponga el producto sobre aparatos que produzcan calor, como por ejemplo radiadores o calentadores. La temperatura ambiental no debe superar la temperatura máxima especificada en la hoja de datos.

Informaciones de seguridad

27. Baterías y acumuladores no deben de ser expuestos a temperaturas altas o al fuego. Guardar baterías y acumuladores fuera del alcance de los niños. Si las baterías o los acumuladores no son cambiados con la debida atención existirá peligro de explosión (atención celulas de Litio). Cambiar las baterías o los acumuladores solamente por los del tipo R&S correspondiente (ver lista de piezas de recambio). Baterías y acumuladores son deshechos problemáticos. Por favor tirenlos en los recipientes especiales para este fin. Por favor tengan en cuenta las prescripciones nacionales de cada país referente al tratamiento de deshechos. Nunca sometan las baterías o acumuladores a un corto circuito.
28. Tengan en consideración de que en caso de un incendio pueden escaparse gases tóxicos del producto, que pueden causar daños a la salud.
29. Por favor tengan en cuenta que en caso de un incendio pueden desprenderse del producto agentes venenosos (gases, líquidos etc.) que pueden generar daños a la salud.
30. No sitúe el producto encima de superficies, vehículos, estantes o mesas, que por sus características de peso o de estabilidad no sean aptas para él. Siga siempre las instrucciones de instalación del fabricante cuando instale y asegure el producto en objetos o estructuras (por ejemplo paredes y estantes).
31. Las asas instaladas en los productos sirven solamente de ayuda para el manejo que solamente está previsto para personas. Por eso no está permitido utilizar las asas para la sujecion en o sobre medios de transporte como por ejemplo grúas, carretillas elevadoras de horquilla, carros etc. El usuario es responsable de que los productos sean sujetados de forma segura a los medios de transporte y de que las prescripciones de seguridad del fabricante de los medios de transporte sean tenidas en cuenta. En caso de que no se tengan en cuenta pueden causarse daños en personas y objetos.
32. Si llega a utilizar el producto dentro de un vehículo, queda en la responsabilidad absoluta del conductor que conducir el vehículo de manera segura. Asegure el producto dentro del vehículo debidamente para evitar en caso de un accidente las lesiones u otra clase de daños. No utilice nunca el producto dentro de un vehículo en movimiento si esto pudiera distraer al conductor. Siempre queda en la responsabilidad absoluta del conductor la seguridad del vehículo y el fabricante no asumirá ninguna clase de responsabilidad por accidentes o colisiones.
33. Dado el caso de que esté integrado un producto de laser en un producto R&S (por ejemplo CD/DVD-ROM) no utilice otras instalaciones o funciones que las descritas en la documentación. De otra manera pondrá en peligro su salud, ya que el rayo laser puede dañar irreversiblemente sus ojos. Nunca trate de descomponer estos productos. Nunca mire dentro del rayo laser.



Qualitätszertifikat

Sehr geehrter Kunde,

Sie haben sich für den Kauf eines Rohde & Schwarz-Produktes entschieden. Hiermit erhalten Sie ein nach modernsten Fertigungsmethoden hergestelltes Produkt. Es wurde nach den Regeln unseres Qualitätsmanagementsystems entwickelt, gefertigt und geprüft. Das Rohde & Schwarz-Qualitätsmanagementsystem ist u.a. nach ISO 9001 und ISO 14001 zertifiziert.

Certificate of quality

Dear Customer,

You have decided to buy a Rohde & Schwarz product. You are thus assured of receiving a product that is manufactured using the most modern methods available. This product was developed, manufactured and tested in compliance with our quality management system standards. The Rohde & Schwarz quality management system is certified according to standards such as ISO 9001 and ISO 14001.

Certificat de qualité

Cher client,

Vous avez choisi d'acheter un produit Rohde & Schwarz. Vous disposez donc d'un produit fabriqué d'après les méthodes les plus avancées. Le développement, la fabrication et les tests respectent nos normes de gestion qualité. Le système de gestion qualité de Rohde & Schwarz a été homologué, entre autres, conformément aux normes ISO 9001 et ISO 14001.



ROHDE & SCHWARZ



Certificate No.: 2002-36

This is to certify that:

Equipment type	Stock No.	Designation
NRP	1143.8500.02	Power Meter
NRP-B1	1146.9008.02	Sensor Check Source
NRP-B2	1146.8801.02	Second Sensor Input
NRP-B5	1146.9608.02	3rd und 4th Sensor
NRP-B6	1146.9908.02	Rear-Panel Sensor
NRP-Z3	1146.7005.02	USB Adapter
NRP-Z4	1146.8001.02	USB Adapter
NRP-Z11	1138.3004.02	Average Power Sensor
NRP-Z21	1137.6000.02	Average Power Sensor

complies with the provisions of the Directive of the Council of the European Union on the approximation of the laws of the Member States

- relating to electrical equipment for use within defined voltage limits
(73/23/EEC revised by 93/68/EEC)
- relating to electromagnetic compatibility
(89/336/EEC revised by 91/263/EEC, 92/31/EEC, 93/68/EEC)

Conformity is proven by compliance with the following standards:

EN61010-1 : 1993 + A2 : 1995
EN55011 : 1998 + A1 : 1999
EN61326 : 1997 + A1 : 1998 + A2 : 2001

For the assessment of electromagnetic compatibility, the limits of radio interference for Class B equipment as well as the immunity to interference for operation in industry have been used as a basis.

Affixing the EC conformity mark as from 2002

ROHDE & SCHWARZ GmbH & Co. KG
Mühldorfstr. 15, D-81671 München

Munich, 2002-06-27

Central Quality Management FS-QZ / Becker

Support Center

Telefon / Telephone: +49 (0)180 512 42 42

Fax: +49 89 41 29 137 77

E-mail: CustomerSupport@rohde-schwarz.com

Für technische Fragen zu diesem Rohde & Schwarz-Gerät steht Ihnen die Hotline der Rohde & Schwarz Vertriebs-GmbH, Support Center, zur Verfügung.

Unser Team bespricht mit Ihnen Ihre Fragen und sucht Lösungen für Ihre Probleme.

Die Hotline ist Montag bis Freitag von 8.00 bis 17.00 Uhr MEZ besetzt.

Bei Anfragen außerhalb der Geschäftszeiten hinterlassen Sie bitte eine Nachricht oder senden Sie eine Notiz per Fax oder E-Mail. Wir setzen uns dann baldmöglichst mit Ihnen in Verbindung.



Um Ihr Gerät stets auf dem neuesten Stand zu halten, abonnieren Sie bitte Ihren persönlichen Newsletter unter

<http://www.rohde-schwarz.com/www/response.nsf/newsletterpreselection>.

Sie erhalten dann regelmäßig Informationen über Rohde & Schwarz-Produkte Ihrer Wahl, über Firmware-Erweiterungen, neue Teiler und Applikationsschriften.

Should you have any technical questions concerning this Rohde & Schwarz product, please contact the hotline of Rohde & Schwarz Vertriebs-GmbH, Support Center.

Our hotline team will answer your questions and find solutions to your problems.

You can reach the hotline Monday through Friday from 8:00 until 17:00 CET.

If you need assistance outside office hours, please leave a message or send us a fax or e-mail. We will contact you as soon as possible.



To keep your instrument always up to date, please subscribe to your personal newsletter at

<http://www.rohde-schwarz.com/www/response.nsf/newsletterpreselection>.

As a subscriber, you will receive information about your selection of Rohde & Schwarz products, about firmware extensions, new drivers and application notes on a regular basis.



ROHDE & SCHWARZ

Adressen/Addresses

FIRMENSITZ/HEADQUARTERS

	Phone	
	Fax	
	E-mail	
Rohde & Schwarz GmbH & Co. KG	+49 (89) 41 29-0	
Mühlhofstraße 15 · D-81671 München	+49 89 4129-121 64	
Postfach 80 14 69 · D-81614 München	-	

WERKE/PLANTS

Rohde & Schwarz Messgerätebau GmbH	+49 (8331) 108-0	
Riedbachstraße 58 · D-87700 Memmingen	+49 (8331) 108-11 24	
Postfach 1652 · D-87686 Memmingen	-	

Rohde & Schwarz GmbH & Co. KG	+49 (9923) 857-0	
Werk Teisnach	+49 (9923) 857-11 74	
Kaikenrieder Straße 27 · D-94244 Teisnach	-	
Postfach 1149 · D-94240 Teisnach		

Rohde & Schwarz GmbH & Co. KG	+49 (2203) 49-0	
Dienstleistungszentrum Köln	+49 (2203) 49 51-308	
Graf-Zeppelin-Straße 18 · D-51147 Köln	info@rsdc.rohde-schwarz.com	
Postfach 98 02 60 · D-51130 Köln	service@rsdc.rohde-schwarz.com	

TOCHTERUNTERNEHMEN/SUBSIDIARIES

Rohde & Schwarz Vertriebs-GmbH	+49 (89) 41 29-137 74	
Mühlhofstraße 15 · D-81671 München	+49 (89) 41 29-137 77	
Postfach 80 14 69 · D-81614 München	-	

Rohde & Schwarz International GmbH	+49 (89) 41 29-129 84	
Mühlhofstraße 15 · D-81671 München	+49 (89) 41 29-120 50	
Postfach 80 14 60 · D-81614 München	-	

Rohde & Schwarz Engineering and Sales GmbH	+49 (89) 41 29-137 11	
Mühlhofstraße 15 · D-81671 München	+49 (89) 41 29-137 23	
Postfach 80 14 29 · D-81614 München	-	

R&S BICK Mobilfunk GmbH	+49 (5042) 998-0	
Fritz-Hahne-Str. 7 · D-31848 Bad Münder	+49 (5042) 998-105	
Postfach 2062 · D-31844 Bad Münder	-	

Rohde & Schwarz FTK GmbH	+49 (30) 658 91-122	
Wendenschlossstraße 168, Haus 28	+49 (30) 655 50-221	
D-12557 Berlin	-	

Rohde & Schwarz SIT GmbH	+49 (30) 658 84-0	
Agastaße 3	+49 (30) 658 84-183	
D-12489 Berlin		

ADRESSEN DEUTSCHLAND/ADDRESSES GERMANY

Rohde & Schwarz Vertriebs-GmbH	+49 89 4129-133 74	
Mühlhofstraße 15 · D-81671 München	+4989 4129-133 77	
Postfach 80 14 69 · D-81614 München	-	

Zweigniederlassungen der Rohde & Schwarz Vertriebs-GmbH/Branch offices of Rohde & Schwarz Vertriebs-GmbH

Zweigniederlassung Nord, Geschäftsstelle Berlin	+49 (30) 34 79 48-0	
Ernst-Reuter-Platz 10 · D-10587 Berlin	+49 (30) 34 79 48 48	
Postfach 100620 · D-10566 Berlin	-	

Zweigniederlassung Büro Bonn	+49 (228) 918 90-0	
Josef-Wirmer-Straße 1-3 · D-53123 Bonn	+49 (228) 25 50 87	
Postfach 140264 · D-53057 Bonn	-	

Zweigniederlassung Nord, Geschäftsstelle Hamburg	+49 (40) 63 29 00-0	
Steilshooper Alle 47 · D-22309 Hamburg	+49 (40) 630 78 70	
Postfach 60 22 40 · D-22232 Hamburg	-	

Zweigniederlassung Mitte, Geschäftsstelle Köln	+49 (2203) 807-0	
Niederlasser Straße 33 · D-51147 Köln	+49 (2203) 807-650	
Postfach 900 149 · D-51111 Köln	-	

Zweigniederlassung Süd, Geschäftsstelle München	+49 (89) 41 86 95-0	
Mühlhofstraße 15 · D-81671 München	+49 (89) 40 47 64	
Postfach 80 14 69 · D-81614 München	-	

Zweigniederlassung Süd, Geschäftsstelle Nürnberg	+49 (911) 642 03-0	
Donaustraße 36	+49 (911) 642 03-33	
D-90451 Nürnberg	-	

Zweigniederlassung Mitte, Geschäftsstelle Neu-Isenburg	+49 (6102) 20 07-0	
Siemensstraße 20	+49 (6102) 20 07 12	
D-63263 Neu-Isenburg	-	

ADRESSEN WELTWEIT/ADDRESSES WORLDWIDE

Albania siehe / see Austria

Algeria	ROHDE & SCHWARZ	+213 (21) 48 20 18
	Bureau d'Alger	+213 (21) 69 46 08
	5B Place de Laperrine	
	16035 Hydra-Alger	

Argentina	PRECISION ELECTRONICA S.R.L.	+541 (14) 331 41 99
	Av. Pde Julio A. Roca 710 - 6° Piso	+541 (14) 334 51 11
	(C1067ABP) Buenos Aires	alberto_lombardi@prec-elec.com.ar

Australia	ROHDE & SCHWARZ (AUSTRALIA) Pty. Ltd.	+61 (2) 88 45 41 00
	Sales Support	+61 (2) 96 38 39 88
	Unit 6	lyndell.james@rsaus.rohde-
	2-8 South Street	schwarz.com
	Rydalmere, N.S.W. 2116	

Austria	ROHDE & SCHWARZ-ÖSTERREICH	+43 (1) 602 61 41-0
	Ges.m.b.H.	+43 (1) 602 61 41-14
		office@rsoe.rohde-schwarz.com

Sonnleithnergasse 20
1100 Wien

Azerbaijan	ROHDE & SCHWARZ Azerbaijan	+994 (12) 93 31 38
	Liaison Office Baku	+994 (12) 93 03 14
	ISR Plaza	RS-Azerbaijan@RUS.Rohde-
	340 Nizami Str.	Schwarz.com
	370000 Baku	

Baltic Countries siehe / see Denmark

Bangladesh	BIL Consortium Ltd.	+880 (2) 881 06 53
	Corporation Office	+880 (2) 882 82 91
	House No: 95/A, Block - 'F'	
	Road No. 4, Banani	
	Dhaka-1213	

Belgium	ROHDE & SCHWARZ BELGIUM N.V.	+32 (2) 721 50 02
	Excelsiorlaan 31 Bus 1	+32 (2) 725 09 36
	1930 Zaventem	info@rsb.rohde-schwarz.com

Brasil	ROHDE & SCHWARZ DO BRASIL LTDA.	+55 (11) 56 44 86 11 (general)
	Av. Alfredo Egidio de Souza Aranha n° 177,	+55 (11) 56 44 86 25 (sales)
	1° andar - Santo Amaro	+55 (11) 56 44 86 36
	04726-170 Sao Paulo - SP	sales-brazil@rsdb.rohde-
		schwarz.com

Brunei	GKL Equipment PTE. Ltd.	+65 (6) 276 06 26
	Jurong Point Post Office	+65 (6) 276 06 29
	P.O.Box 141	gkleqpt@singnet.com.sg
	Singapore 916405	

Bulgaria	ROHDE & SCHWARZ ÖSTERREICH	+359 (2) 963 43 34
	Representation Office Bulgaria	+359 (2) 963 21 97
	39, Fridtjof Nansen Blvd.	rohdebg@rsoe.rohde-schwarz.com
	1000 Sofia	

Bosnia-Herzegovina siehe / see Slovenia

Adressen/Addresses

Canada	ROHDE & SCHWARZ CANADA Inc. 555 March Rd. Kanata, Ontario K2K 2M5	+1 (613) 592 80 00 +1 (613) 592 80 09 cgirwarnauth@rscanada.ca	Denmark	ROHDE & SCHWARZ DANMARK A/S Ejby Industrivej 40 2600 Glostrup	+45 (43) 43 66 99 +45 (43) 43 77 44
Canada	TEKTRONIX CANADA Inc. Test and Measurement 4929 Place Olivia Saint-Laurent, Pq Montreal H4R 2V6	+1 (514) 331 43 34 +1 (514) 331 59 91	Ecuador	REPRESENTACIONES MANFRED WEINZIERL Vía Láctea No. 4 y Vía Sta. Inés P.O.Box 17-22-20309 1722 Cumbayá-Quito	+593 (22) 89 65 97 +593 (22) 89 65 97 mweinzierl@accessinter.net
Chile	DYMEQ Ltda. Av. Larrain 6666 Santiago	+56 (2) 339 20 00 +56 (2) 339 20 10 dnussbaum@dymeq.com	Egypt	U.A.S. Universal Advanced Systems 31 Manshiet El-Bakry Street Heliopolis 11341 Cairo	+20 (2) 455 67 44 +20 (2) 256 17 40 an_uas@intouch.com
China	ROHDE & SCHWARZ China Ltd. Representative Office Shanghai Central Plaza 227 Huangpi North Road RM 807/809 Shanghai 200003	+86 (21) 63 75 00 18 +86 (21) 63 75 91 70	El Salvador	siehe / see Mexico	
China	ROHDE & SCHWARZ China Ltd. Representative Office Beijing Room 602, Parkview Center 2 Jiangtai Road Chao Yang District Beijing 100016	+86 (10) 64 31 28 28 +86 (10) 64 37 98 88 info.rschina@rsbp.rohde- schwarz.com	Estonia	ROHDE & SCHWARZ DANMARK A/S Estonian Branch Office Narva mnt. 13 10151 Tallinn	+372 (6) 14 31 23 +372 (6) 14 31 21 margo.fingling@rsdk.rohde- schwarz.com
China	ROHDE & SCHWARZ China Ltd. Representative Office Guangzhou Room 2903, Metro Plaza 183 Tianhe North Road Guangzhou 510075	+86 (20) 87 55 47 58 +86 (20) 87 55 47 59	Finland	Orbis Oy P.O.Box 15 00421 Helsinki 42	+358 (9) 47 88 30 +358 (9) 53 16 04 info@orbis.fi
China	ROHDE & SCHWARZ China Ltd. Representative Office Chengdu Unit G, 28/F, First City Plaza 308 Shuncheng Avenue Chengdu 610017	+86 (28) 86 52 76 05 to 09 +86 (28) 86 52 76 10 rsbpc@mail.sc.cninfo.net	France	ROHDE & SCHWARZ FRANCE Immeuble "Le Newton" 9-11, rue Jeanne Braconnier 92366 Meudon La Forêt Cédex	+33 (1) 41 36 10 00 +33 (1) 41 36 11 73
China	ROHDE & SCHWARZ China Ltd. Unit 3115 31/F Entertainment Building 30 Queen's Road Central Hongkong	+85 (2) 21 68 06 70 +85 (2) 21 68 08 99	France	Niederlassung/Subsidiary Rennes 37 Rue du Bignon Bât. A F-35510 Cesson Sevigne	+33 (0) 299 51 97 00 +33 (0) 299 51 98 77 -
China	ROHDE & SCHWARZ China Ltd. Representative Office Xi'an Room 10125, Jianguo Hotel Xi'an No. 2, Huzhu Road Xi'an 710048	+86 (29) 321 82 33 +86 (29) 329 60 15 sherry.yu@rsbp.rohde-schwarz.com	France	Niederlassung/Subsidiary Toulouse Technoparc 3 B.P. 501 F-31674 Labège Cédex	+33 (0) 561 39 10 69 +33 (0) 561 39 99 10 -
China	Shanghai ROHDE & SCHWARZ Communication Technology Co.Ltd. Central Plaza, Unit 809 227 Huangpi North Road Shanghai 200003		France	Aix-en-Provence	+33 (0) 494 07 39 94 +33 (0) 494 07 55 11 -
China	Beijing ROHDE & SCHWARZ Communication Technology Co.Ltd. Room 106, Parkview Centre No. 2, Jiangtai Road Chao Yang District Beijing 100016	+86 (10) 64 38 80 80 +86 (10) 64 38 97 06	France	Office Lyon	+33 (0) 478 29 88 10 +33 (0) 478 79 18 57
Croatia	siehe / see Slovenia		France	Office Nancy	+33 (0) 383 54 51 29 +33 (0) 383 54 82 09
Cyprus	HINIS TELECAST LTD. Agiou Thoma 18 Kiti Larnaca 7550	+357 (24) 42 51 78 +357 (24) 42 46 21 hinis@logos.cy.net	Ghana	KOP Engineering Ltd. P.O. Box 11012 3rd Floor Akai House, Osu Accra North	+233 (21) 77 89 13 +233 (21) 701 06 20
Czech Republic	ROHDE & SCHWARZ - Praha s.r.o. Hadovka Office Park Evropská 33c 16000 Praha 6	+420 (2) 24 31 12 32 +420 (2) 24 31 70 43 office@rscz.rohde-schwarz.com	Greece	MERCURY S.A. 6, Loukianou Str. 10675 Athens	+302 (10) 722 92 13 +302 (10) 721 51 98 mercury@hol.gr
			Guatemala	siehe / see Mexico	
			Honduras	siehe / see Mexico	
			Hongkong	Electronic Scientific Engineering 36/F Dorset House, Taikoo Place 979 King's Road Quarry Bay Hong Kong	+852 (25) 07 03 33 +852 (25) 07 09 25 stephenchau@ese.com.hk
			Hungary	ROHDE & SCHWARZ Budapesti Iroda Váci út 169 1138 Budapest	+36 (1) 412 44 60 +36 (1) 412 44 61 rohdehu@rsoe.rohde-schwarz.com
			Iceland	siehe / see Denmark	

Adressen/Addresses

India	ROHDE & SCHWARZ India Pvt. Ltd. Bangalore Office No. 24, Service Road, Domlur 2nd Stage Extension Bangalore - 560 071	+91 (80) 535 23 62 +91 (80) 535 03 61 rsindiab@rsnl.net	Kenya	Excel Enterprises Ltd Dunga Road P.O.Box 42 788 Nairobi	+254 (2) 55 80 88 +254 (2) 54 46 79
India	ROHDE & SCHWARZ India Pvt. Ltd. Hyderabad Office 302 & 303, Millenium Centre 6-3-1099/1100, Somajiguda Hyderabad - 500 016	+91 (40) 23 32 24 16 +91 (40) 23 32 27 32 rsindiah@nd2.dot.net.in	Korea	ROHDE & SCHWARZ Korea Ltd. 83-29 Nonhyun-Dong, Kangnam-Ku Seoul 135-010	+82 (2) 514 45 46 +82 (2) 514 45 49 sales@rskor.rohde-schwarz.com service@rskor.rohde-schwarz.com
India	ROHDE & SCHWARZ India Pvt. Ltd. 244, Okhla Industrial Estate, Phase-III New Delhi 110020	+91 (11) 26 32 63 81 +91 (11) 26 32 63 73 sales@rsindia.rohde-schwarz.com services@rsindia.rohde-schwarz.com	Kuwait	Group Five Trading & Contracting Co. Mezanine Floor Al-Bana Towers Ahmad Al Jaber Street Sharq	+965 (244) 91 72/73/74 +965 (244) 95 28 jk_agarwal@yahoo.com
India	ROHDE & SCHWARZ India Pvt. Ltd. RS India Mumbai Office B-603, Remi Bizcourt, Shah Industrial Estate, Off Veera Desai Road Mumbai - 400 058	+91 (22) 26 30 18 10 +91 (22) 26 32 63 73 rsindiam@rsnl.net	Latvia	ROHDE & SCHWARZ DANMARK A/S Latvian Branch Office Merkela iela 21-301 1050 Riga	+371 (7) 50 23 55 +371 (7) 50 23 60 rsdk@rsdk.rohde-schwarz.com
Indonesia	PT ROHDE & SCHWARZ Indonesia Graha Paramita 5th Floor Jln. Denpasar Raya Blok D-2 Jakarta 12940	+62 (21) 252 36 08 +62 (21) 252 36 07 sales@rsbj.rohde-schwarz.com services@rsbj.rohde-schwarz.com	Lebanon	ROHDE & SCHWARZ Liaison Office c/o Haji Abdullah Alireza Co. Ltd. P.O.Box 361 Riyadh 11411	+966 (1) 465 64 28 Ext. 303 +966 (1) 465 64 28 Ext. 229 chris.porzky@rsd.rohde-schwarz.com
Iran	ROHDE & SCHWARZ IRAN Groundfloor No. 1, 14th Street Khaled Eslamboli (Vozara) Ave. 15117 Tehran	+98 (21) 872 42 96 +98 (21) 871 90 12 rs-tehran@neda.net	Liechtenstein	siehe / see Switzerland	
Ireland	siehe / see United Kingdom		Lithuania	ROHDE & SCHWARZ DANMARK A/S Lithuanian Office Lukiskiu 5-228 2600 Vilnius	+370 (5) 239 50 10 +370 (5) 239 50 11
Israel	EASTRONICS LTD. Messtechnik / T&M Equipment 11 Rozanis St. P.O.Box 39300 Tel Aviv 61392	+972 (3) 645 87 77 +972 (3) 645 86 66 david_hasky@easx.co.il	Luxembourg	siehe / see Belgium	
Israel	J.M. Moss (Engineering) Ltd. Kommunikationstechnik/ Communications Equipment 9 Oded Street P.O.Box 967 52109 Ramat Gan	+972 (3) 631 20 57 +972 (3) 631 40 58 jmoss@zahav.net.il	Macedonia	siehe / see Slovenia	
Italy	ROHDE & SCHWARZ ITALIA S.p.a. Centro Direzionale Lombardo Via Roma 108 20060 Cassina de Pecchi (MI)	+39 (02) 95 70 42 03 +39 (02) 95 30 27 72 ornella.crippa@rsi.rohde-schwarz.com	Malaysia	DAGANG TEKNIK SDN. BHD. No. 9, Jalan SS 4D/2 Selangor Darul Ehsan 47301 Petaling Jaya	+60 (3) 27 03 55 68 +60 (3) 27 03 34 39 mey.nara@danik.com.my
Italy	ROHDE & SCHWARZ ITALIA S.p.a. Via Tiburtina 1182 00156 Roma	+39 (06) 41 59 82 18 +39 (06) 41 59 82 70	Malta	ITEC International Technology Ltd B'Kara Road San Gwann SGN 08	+356 (21) 37 43 00 or 37 43 29 +356 (21) 37 43 53 sales@itec.com.mt
Japan	ADVANTEST Corporation RS Sales Department 1-32-1, Asahi-cho Nerima-ku Tokyo 179-0071	+81 (3) 39 30 41 90 +81 (3) 39 30 41 86 RSSales@advantest.co.jp	Mexico	Rohde & Schwarz de Mexico (RSMX) S. de R.L. de C.V. German Centre Oficina 4-2-2 Av. Santa Fé 170 Col. Lomas de Santa Fé 01210 Mexico D.F.	+52 (55) 85 03 99 13 +52 (55) 85 03 99 16 latinoamerica@rsd.rohde-schwarz.com
Jordan	Jordan Crown Engineering & Trading Co. Jabal Amman, Second Circle Youssef Ezzideen Street P.O.Box 830414 Amman, 11183	+962 (6) 462 17 29 +962 (6) 465 96 72 jocrown@go.com.jo	Mexico	Rohde & Schwarz de Mexico (RSMX) Av. Prol. Americas No. 1600, 2° Piso Col. Country Club Guadalajara, Jal. Mexico CP, 44610	+52 (33) 36 78 91 70 +52 (33) 36 78 92 00
Kazakhstan	ROHDE & SCHWARZ Kazakhstan Representative Office Almaty Pl. Respubliki 15 480013 Almaty	+7 (32) 72 63 55 55 +7 (32) 72 63 46 33 RS-Kazakhstan@RUS-Rohde-Schwarz.com	Moldavia	siehe / see Romania	
			Netherlands	ROHDE & SCHWARZ NEDERLAND B.V. Perkinsbaan 1 3439 ND Nieuwegein	+31 (30) 600 17 00 +31 (30) 600 17 99 info@rsn.rohde-schwarz.com
			New Zealand	Nichecom 1 Lincoln Ave. Tawa, Wellington	+64 (4) 232 32 33 +64 (4) 232 32 30 rob@nichecom.co.nz
			Nicaragua	siehe / see Mexico	
			Nigeria	Ferrostaal (NIGERIA) Ltd. P.O. Box 72021 27/29 Adeyamo Alkaija Street Victoria Island Lagos	+234 (1) 262 00 60 +234 (1) 262 00 64 fs-nig@linkserve.com.ng

Adressen/Addresses

Norway	ROHDE & SCHWARZ NORGE AS Enebakkeien 302 B 1188 Oslo	+47 (23) 38 66 00 +47 (23) 38 66 01	Sri Lanka	LANKA AVIONICS 658/1/1, Negombo Road Mattumagala Ragama	+94 (1) 95 66 78 +94 (1) 95 83 11 lankavio@sltnet.lk
Oman	Mustafa Sultan Science & Industry Co. LLC. P.O.Box 3340 Postal Code 112 Ruwi	+968 63 60 00 +968 60 70 66 m-aziz@mustafasultan.com	Sudan	SolarMan Co. Ltd. P.O.Box 11 545 North of Fraouq Cementry 6/7/9 Bldg. 16 Karthoum	+249 (11) 47 31 08 +249 (11) 47 31 38 solarman29@hotmail.com
Pakistan	Siemens Pakistan 23, West Jinnah Avenue Islamabad	+92 (51) 227 22 00 +92 (51) 227 54 98 reza.bokhary@siemens.com.pk	Sweden	ROHDE & SCHWARZ SVERIGE AB Marketing Div. Flygfältsgatan 15 128 30 Skarpnäck	+46 (8) 605 19 00 +46 (8) 605 19 80 info@rss.se
Panama	siehe / see Mexico				
Papua-New Guinea	siehe / see Australia				
Philippines	MARCOM INDUSTRIAL EQUIPMENT, Inc. 6-L Vernida I Condominium 120 Amorsolo St. Legaspi Village Makati City/ Philippines 1229	+63 (2) 813 29 31 +63 (2) 810 58 07 marcom@i-next.net	Switzerland	Roschi Rohde & Schwarz AG Mühlestr. 7 3063 Ittigen	+41 (31) 922 15 22 +41 (31) 921 81 01 sales@roschi.rohde-schwarz.com
Poland	ROHDE & SCHWARZ Österreich SP.z o.o. Przedstawicielstwo w Polsce ul. Stawki 2, Pietro 28 00-193 Warszawa	+48 (22) 860 64 94 +48 (22) 860 64 99 rohdepl@rsoe.rohde-schwarz.com	Syria	Electro Scientific Office Baghdad Street Dawara Clinical Lab. Bldg P.O.Box 8162 Damascus	+963 (11) 231 59 74 +963 (11) 231 88 75 memo@hamshointl.com
Portugal	Rohde & Schwarz Portugal, Lda. Alameda Antonio Sergio, n° 7 R/C, Sala A 2795-023 Linda-a-Velha	+351 (21) 415 57 00 +351 (21) 415 57 10 telerus@mail.telepac.pt	Taiwan	Lancer Communication Co. Ltd. for Div. 1 and 7 16F, No. 30, Pei-Ping East Road Taipei	+886 (2) 23 91 10 02 +886 (2) 23 95 82 82 info@lancercomm.com.tw
Romania	ROHDE & SCHWARZ Representation Office Bucharest Str. Uranus 98 Sc. 2, Et. 5, Ap. 36 76102 Bucuresti, Sector 5	+40 (21) 410 68 46 +40 (21) 411 20 13 rohdero@rsoe.rohde-schwarz.com	Taiwan	System Communication Co. Ltd. for Div. 2 and 8 16F, No. 30, Pei-Ping East Road Taipei	+886 (2) 23 91 10 02 +886 (2) 23 95 82 82 info@lancercomm.com.tw
Russian Federation	ROHDE & SCHWARZ Representative Office Moscow 119180, Yakimanskaya nab., 2 Moscow	+7 (095) 745 88 50 to 53 +7 (095) 745 88 50 to 53 rohderus@rsoe.rohde-schwarz.com	Tanzania	SSTL Group P.O. Box 7512 Dunga Street Plot 343/345 Dar es Salaam	+255 (22) 276 00 37 +255 (22) 276 02 93 sstl@twiga.com
Saudi Arabia	Mr. Chris Porzky ROHDE & SCHWARZ International GmbH c/o Haji Abdullah Alireza Co. Ltd. P.O.Box 361 Riyadh 11411	+966 (1) 465 64 28 Ext. 303 +966 (1) 465 6428 Ext. 229 chris.porzky@rsd.rohde-schwarz.com	Thailand	Schmidt Electronics (Thailand) Ltd. 63 Government Housing Bank Bldg. Tower II, 19th floor, Rama 9 Rd. Huaykwang, Bangkok Bangkok 10320	+66 (2) 643 13 30 to 39 +66 (2) 643 13 40 kamthonthuyot@schmidtthailand.com
Serbia-Montenegro	Representative Office Belgrade Tose Jovanovica 7 11030 Beograd	+381 (11) 305 50 25 +381 (11) 305 50 24	Thailand	TPP Operation Co., Ltd. 41/5 Mooban Tarinee Boromrajchonnee Road Talingchan, Bangkok 10170	+66 (2) 880 93 47 +66 (2) 880 93 47 thipsukon@tpp-operation.com
Slovak Republic	Specialne systémy a software, a.s. Svrčia ul. 841 04 Bratislava	+421 (2) 65 42 24 88 +421 (2) 65 42 07 68 stefan.lozek@special.sk	Trinidad & Tobago	siehe / see Mexico	
Slovenia	ROHDE & SCHWARZ Representation Ljubljana Tbilisjska 89 1000 Ljubljana	+386 (1) 423 46 51 +386 (1) 423 46 11 rohdesi@rsoe.rohde-schwarz.com	Turkey	ROHDE & SCHWARZ International GmbH Liaison Office Istanbul Bagdad Cad. 191/3, Arda Apt. B-Blok 81030 Selamicesme-Istanbul	+90 (216) 385 19 17 +90 (216) 385 19 18 rsturk@superonline.com
South Africa	Protea Data Systems (Pty.) Ltd. Communications and Measurement Division Private Bag X19 Bramley 2018	+27 (11) 719 57 00 +27 (11) 786 58 91 unicm@protea.co.za	Ukraine	ROHDE & SCHWARZ Representative Office Kiev 4, Patris Loumoumba ul 01042 Kiev	+38 (044) 268 60 55 +38 (044) 268 83 64 rohdeukr@rsoe.rohde-schwarz.com
South Africa	Protea Data Systems (Pty.) Ltd. Cape Town Branch Unit G9, Centurion Business Park Bosmandam Road Milnerton Cape Town, 7441	+27 (21) 555 36 32 +27 (21) 555 42 67 unicm@protea.co.za	United Arab Emirates	ROHDE & SCHWARZ International GmbH Liaison Office Abu Dhabi P.O. Box 31156 Abu Dhabi	+971 (2) 633 56 70 +971 (2) 633 56 71 michael.rogler@rsd.rohde-schwarz.com
Spain	ROHDE & SCHWARZ ESPANA S.A. Salcedo, 11 28034 Madrid	+34 (91) 334 10 70 +34 (91) 329 05 06 rses@rses-rohde-schwarz.com	United Arab Emirates	ROHDE & SCHWARZ Bick Mobile Communication P.O.Box 17466 Dubai	+971 (4) 883 71 35 +971 (4) 883 71 36 www.rsbeck.de

Adressen/Addresses

United Arab Emirates	ROHDE & SCHWARZ Emirates L.L.C. P.O.Box 31156 Abu Dhabi	+971 (2) 631 20 40 +971 (2) 631 30 40 rsuaeam@emirates.net.ae
United Kingdom	ROHDE & SCHWARZ UK Ltd. Ancells Business Park Fleet Hampshire GU 51 2UZ England	+44 (1252) 81 88 88 (sales) +44 (1252) 81 88 18 (service) +44 (1252) 81 14 47 sales@rsuk.rohde-schwarz.com
Uruguay	AEROMARINE S.A. Cerro Largo 1497 11200 Montevideo	+598 (2) 400 39 62 +598 (2) 401 85 97 mjn@aeromarine.com.uy
USA	ROHDE & SCHWARZ, Inc. Broadcast & Comm. Equipment (US Headquarters) 7150-K Riverwood Drive Columbia, MD 21046	+1 (410) 910 78 00 +1 (410) 910 78 01 rsatv@rsa.rohde-schwarz.com rsacomms@rsa.rohde-schwarz.com
USA	Rohde & Schwarz Inc. Marketing & Support Center / T&M Equipment 2540 SW Alan Blumlein Way M/S 58-925 Beaverton, OR 97077-0001	+1 (503) 627 26 84 +1 (503) 627 25 65 info@rsa.rohde-schwarz.com
USA	Rohde & Schwarz Inc. Systems & EMI Products 8080 Tristar Drive Suite 120 Irving, Texas 75063	+1 (469) 713 53 00 +1 (469) 713 53 01 info@rsa.rohde-schwarz.com
Venezuela	EQUILAB TELECOM C.A. Centro Seguros La Paz Piso 6, Local E-61 Ava. Francisco de Miranda Boleita, Caracas 1070	+58 (2) 12 34 46 26 +58 (2) 122 39 52 05 r_ramirez@equilabtelecom.com
Venezuela	REPRESENTACIONES BOPIC S.A. Calle C-4 Qta. San Jose Urb. Caurimare Caracas 1061	+58 (2) 129 85 21 29 +58 (2) 129 85 39 94 incotr@cantv.net
Vietnam	Schmidt Vietnam Co., (H.K.) Ltd., Representative Office in Hanoi Intern. Technology Centre 8/F, HITC Building 239 Xuan Thuy Road Cau Giay, Tu Liem Hanoi	+84 (4) 834 61 86 +84 (4) 834 61 88 svnhn@schmidtgroup.com
West Indies	siehe / see Mexico	

Table of Contents

1	Putting into Operation	1.1
	Unpacking the sensor	1.1
	Connecting the sensor	1.1
	Operation with the R&S NRP basic unit.....	1.2
	Connecting the sensor to the R&S NRP basic unit.....	1.2
	Connecting the sensor to the DUT	1.2
	PC control.....	1.2
	Hardware and software requirements	1.2
	Operation via the Active USB Adapter R&S NRP-Z3	1.4
	Operation via the Passive USB Adapter R&S NRP-Z4.....	1.5
	Connecting the sensor to the DUT	1.5

Figs.

Fig. 1-1 Displaying the total available power of a USB port 1.3

Fig. 1-2 Configuration with Active USB Adapter R&S NRP-Z3 1.4

Fig. 1-3 Changing the primary adapter..... 1.4

Fig. 1-4 Configuration with Passive USB Adapter R&S NRP-Z4 1.5

1 Putting into Operation



Follow the instructions below precisely to prevent damage to the sensor – particularly when you are putting it into operation for the first time.

Unpacking the sensor

Remove the sensor from its packing and check that nothing is missing. Inspect all items for damage. If you discover any damage, inform the carrier responsible immediately and keep the packing to support any claims for compensation.

It is also best to use the original packing if the sensor is to be shipped or transported at a later date..



The sensor contains components which can be destroyed by electrostatic discharges. To prevent this happening, never touch the inner conductor of the RF connector and never open the sensor.

Connecting the sensor



To prevent EMI, the sensor must never be operated with its enclosure wholly or partially removed. Only use shielded cables that meet the relevant EMC standards.

Never exceed the maximum RF power limit. Even brief overloads can destroy the sensor.

In many cases, the RF connector only requires manual tightening. However, for maximal measurement accuracy, the RF connector must be tightened using a torque wrench with a nominal torque of 1.36 Nm (12" lbs.).

Operation with the R&S NRP basic unit

Connecting the sensor to the R&S NRP basic unit

The sensor can be connected to the R&S NRP basic unit when it is in operation. The interface connector must be inserted, red marking upwards, into one of the R&S NRP basic unit's sensor connectors. When the sensor is connected, it is detected by the R&S NRP basic unit and initialized.

Connecting the sensor to the DUT

The Sensor R&S NRP-Z11/-Z21 has a male N connector and so can be connected to any standard female N connector. Using light pressure, and keeping the male N connector perpendicular, insert it into the female N connector and tighten the N connector locking nut (right-hand thread).

PC control

Hardware and software requirements

The following requirements must be met if the sensor is to be controlled by a PC via an interface adapter:

- The PC must have a USB port.
- The PC's operating system must support the USB port. This is the case with Windows™ 98, Windows™ ME, Windows™ 2000, Windows™ XP and more recent versions of the Windows™ operating system.
- The USB device drivers in the supplied *NRP Toolkit* software package must be installed.

If these requirements are met, the sensor can be controlled using a suitable application program such as the NrpFlashup program contained in the NRP Toolkit (includes the modules Power Viewer, USB Terminal, Firmware Update and Update S-Parameters).

When you insert the CD-ROM supplied with the R&S NRP, the NRP Toolkit is automatically installed on your PC. The rest of the procedure is self-explanatory.

The sensor can be powered in two ways:

- *Self-powered* from a separate power supply via the Active USB Adapter R&S NRP-Z3.
- *Bus-powered* from the PC or a USB hub with its own power supply (*self-powered hub*) via the Active USB Adapter R&S NRP-Z3 or via the Passive USB Adapter R&S NRP-Z4.

As the sensor is a *high-power device*, there is no guarantee that it can be powered from all types of laptop or notebook in the *bus-powered* mode. To be sure, you should determine the current at the USB connectors beforehand:



- In the Windows™ start menu, select **Settings – Control Panel**
- Select the **System** icon
- Select the **Hardware** tab
- By clicking on the button with that name, start the **Device Manager**
- Open **USB Controller** (all USB controllers, hubs and USB devices are listed here)
- Double-click on **USB Root Hub** or select **Properties** in the context menu (use the right-hand mouse button)
- Select the **Power** tab (Fig. 1-1). If the hub is self-powered and the total power available is, as indicated by **Hub Information**, 500 mA per port, high-power devices can be connected.

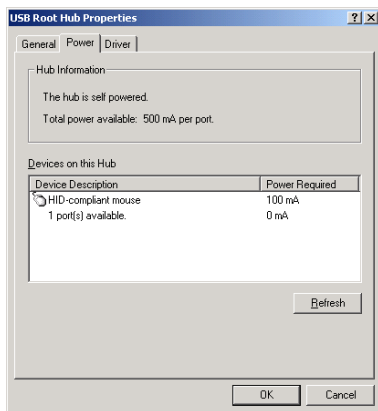

Fig. 1-1 Displaying the total available power of a USB port

If you have any doubts, ask the manufacturer if the USB port on your laptop or notebook can handle *high-power devices*.

Operation via the Active USB Adapter R&S NRP-Z3

Figure 1-2 shows the configuration with the Active USB Adapter R&S NRP-Z3, which also makes it possible to feed in a trigger signal for the *Timeslot* and *Scope* modes. The order in which the cables are connected is not critical.

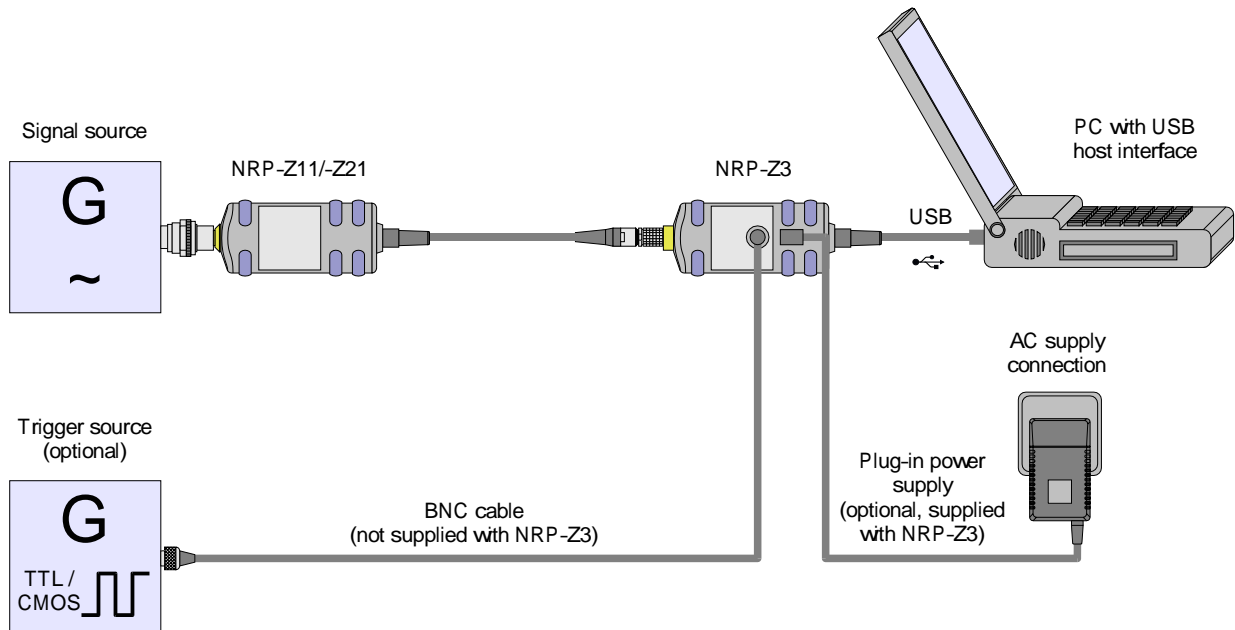

Fig. 1-2 Configuration with Active USB Adapter R&S NRP-Z3

The plug-in power supply for the R&S NRP-Z3 can be powered from a single-phase AC source with a nominal voltage range of 100 V to 240 V and a nominal frequency between 50 Hz and 60 Hz. The plug-in power supply autoselects to the applied AC voltage. No manual voltage selection is required.

The plug-in power supply comes with four primary adapters for Europe, the UK, the USA and Australia. No tools of any kind are required to change the primary adapter. The adapter is pulled out manually and another adapter inserted until it locks (Fig. 1-3).

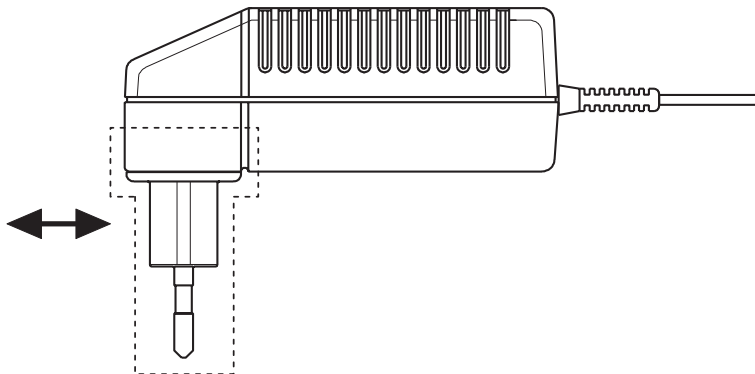

Fig. 1-3 Changing the primary adapter

The plug-in power supply is short-circuit-proof and has an internal fuse. It is not possible to replace this fuse or open the plug-in power supply.



The plug-in power supply is not intended for outdoor use.

Keep within the temperature range of 0°C to 50°C.

If there is any condensation on the plug-in power supply, dry it off before connecting it to the AC supply.

Operation via the Passive USB Adapter R&S NRP-Z4

Fig. 1-4 is a schematic of the measurement setup. The order in which the cables are connected is not critical.

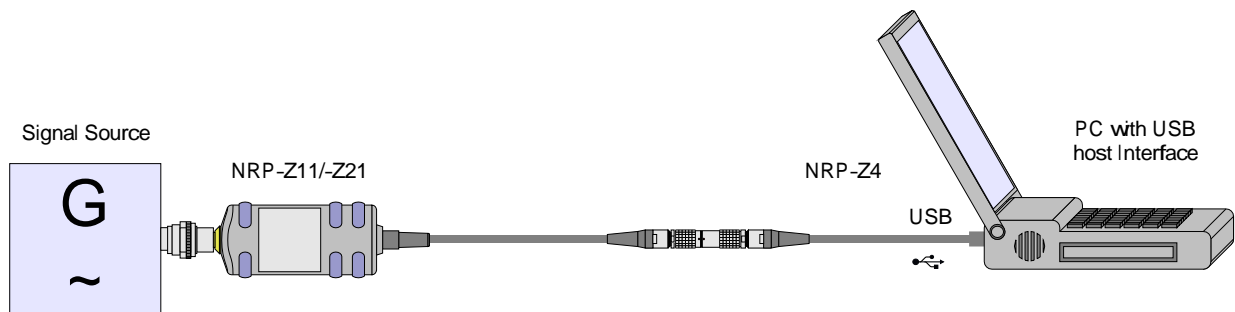

Fig. 1-4 Configuration with Passive USB Adapter R&S NRP-Z4

Connecting the sensor to the DUT

See the section “Operation with the R&S NRP basic unit” for information on how to connect the sensor to the DUT.

Table of Contents

2 Virtual Power Meter 2.1

Overview 2.1

 Menus..... 2.3

Figs.

Fig. 2-1 **Power Viewer** virtual power meter 2.1

Tables

Table 2-1 Virtual power meter keys 2.2
Table 2-2 Virtual power meter entry fields 2.2

2 Virtual Power Meter

You will find the **NrpFlashup** program for controlling sensors with a PC under Windows™ on the CD-ROM that accompanies the sensor. The program comprises several modules which can be started centrally via the Windows™ start-menu entry **NRP Toolkit**.

This section describes the **Power Viewer** program module. This is a virtual power meter which only uses a cut-down set of the sensor's functions. This means that after an extremely brief familiarization period, the user can measure the average power of modulated signals.

The other modules in **NrpFlashup** are described in Chapter 3 of the operating manual (**Terminal** and **Update S-Parameters** modules) or in the service manual (**Firmware Update** module).

Overview

Start the virtual power meter using the **NRP Toolkit – Power Viewer** start-menu entry. The **Power Viewer** program window is displayed (Fig. 2-1).

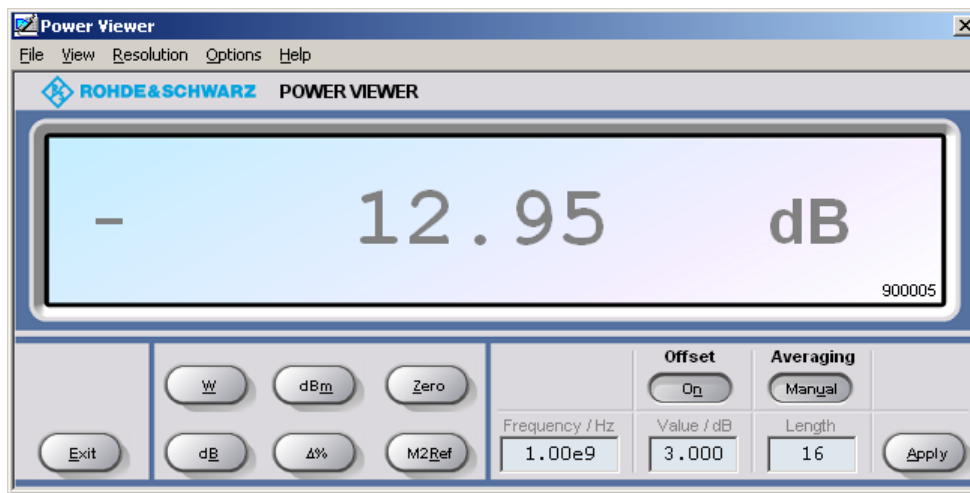

Fig. 2-1 **Power Viewer** – virtual power meter

The result display occupies most of the program window. The result, unit and additional sensor status information are displayed. The serial number of the sensor is displayed in the bottom right. The program window also contains animated buttons and entry fields (see Table 2-1 and Table 2-2).

Table 2-1 Virtual power meter keys

Button	Function	Key combination
Exit	Terminates the program. The current settings are saved and recalled the next time the program is started.	Alt + E
W	Selects Watt as the display unit.	Alt + W
dBm	Selects dBm as the display unit.	Alt + M
Zero	Zeroes the sensor.	Alt + Z
dB	Selects dB as the display unit. This is the log of the ratio of the measured value to the reference value.	Alt + B
Δ%	Selects % as the display unit. The difference between the measured value and the reference value is expressed as a percentage.	Alt + %
M2Ref	Makes the current measured value the reference value for the relative display units dB and %.	Alt + R
Offset On/Off	Turns the offset correction for the sensor on or off. If the offset correction is Off, the Offset/dB entry field has a grey background.	Alt + N
Averaging Man/Auto	Turns auto-averaging on or off. When auto-averaging is on, the Length entry field has a grey background; the current averaging factor is displayed.	Alt + T
Apply	Accepts edited numerical values in the Frequency/Hz , Value/dB and Length entry fields and transfers them to the sensor.	Alt + A or Enter key

Table 2-2 Virtual power meter entry fields

Entry field	Function
Frequency/Hz	Frequency of the RF carrier in Hertz.
Value/dB	Attenuation in dB of the twoport connected to the sensor. The valid range is -100 to 100. The offset correction must be activated beforehand with the Offset On/Off button if this entry field is to be edited.
Length	Length of the averaging filter (= averaging factor). The valid range is 1 to 65536. Averaging must be set to manual with the Averaging Man/Auto button if this entry field is to be edited.

Scientific notation can also be used for the entry fields. If an invalid entry is made, an error message is output. An edited numerical value will not be transferred to the sensor unless you use the **Apply** button or the Enter key to terminate the entry.

Menus

The menu bar can be used to call less frequently used functions.

File **Start Log ...** Opens a file-selection dialog to specify the path and name of the log file. Clicking the **Save** button starts the recording. All displayed values are written line-by-line to the log file with the date (format: YY/MM/DD) and time (format: hh:mm:ss.ms). Example:
-22.51 dBm (03/02/25 15:37:25.310)

Stop Log Ends the log-file recording.

View **Display Refresh Rate** Opens a dialog box to adjust the display refresh rate. The time in milliseconds between two refresh operations is entered. The default setting is 200 ms.



Colours Opens a dialog box to select the background colour for

- the result,
- the unit,
- the text in the number fields or
- the key labelling.

**Result
Unit
Edit
Button**

Resolution For setting the result resolution. If auto-averaging has been selected, a higher resolution leads to a greater averaging factor, which means a longer result settling time.

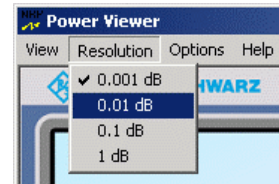

Options **Read Sensor Status ...** Reads the current sensor status. A parameter list is output.

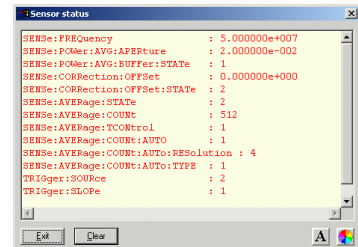

Read Error Queue ... Reads the error queue. All the error messages that have been issued since the last call are read line-by-line. A tick before this menu entry indicates that an error has occurred.

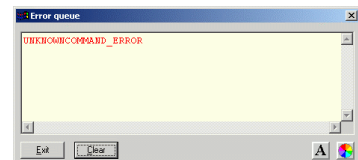

Simulation ...

For trying out the functions of the virtual power meter without actually connecting a sensor. The display alternates between **Measurement Value 1 & Measurement Value 2** with a period given by **Interval**. Simulation can be activated immediately with the **Activate** check box.

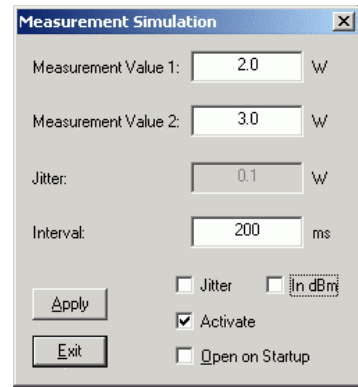
**Reset Sensor**

Initializes the sensor. Any previous zeroing remains valid.

Help**Contents**

Opens the table of contents for the online-help facility.

About

Displays information about the program version used, etc.

Table of Contents

- 3 Manual Operation..... 3.1**
 - Program module "Terminal" 3.1**
 - Main control elements 3.1
 - Menus..... 3.3
 - Program module "Firmware Update" 3.6**
 - Program module "Update S-Parameters" 3.6**
 - Fundamentals 3.6
 - Procedure..... 3.9

Figs.

Fig. 3-1 Sending commands using the **Input** field..... 3.1
Fig. 3-2 Sending commands using command files..... 3.2
Fig. 3-3 Dialog window for loading an s-parameter table 3.9
Fig. 3-4 Dialog window for loading the backup file of a calibration data set..... 3.10

Tables

Table 3-1 Buttons assigned to the **Input** field..... 3.2
Table 3-2 Buttons assigned to the **Command File** field..... 3.2
Table 3-3 Buttons assigned to the **Output** field..... 3.3
Table 3-4 Uncertainties of the s-parameter test system (example)..... 3.7
Table 3-5 Interpolated uncertainties of measurement frequencies for s-parameters (example)..... 3.7

3 Manual Operation

The previous section describes the Power Viewer program module supplied with the instrument. This module simplifies the most frequently used function of a power meter – measuring the average power of an RF signal of almost any modulation. Other program modules are also part of the supplied equipment and can be selected in the Start menu:

- **Power Viewer:** A detailed description of this virtual power meter module is provided in section 2.
- **Terminal:** Program module for sending commands and command sequences to the sensor and for displaying measurement results, status information and other data from the sensor
- **Firmware Update:** Program module for updating the sensor firmware
- **Update S-Parameters:** Program module for loading an s-parameter table into the sensor

Program module "Terminal"

Main control elements

With the USB terminal, commands and command sequences can be sent to the sensor in two different ways:

- Commands are entered in the **Input** field (Fig. 3-1). Consecutive commands can be entered as separate lines, one below the other. The buttons associated with the **Input** field are described in Table 3-1.
- Commands or command sequences are stored in *command files*. Command files are created with a text editor, for instance, and then stored. They can be called as often as required (Fig. 3-2). The buttons of the **Command File** field are described in Table 3-2.

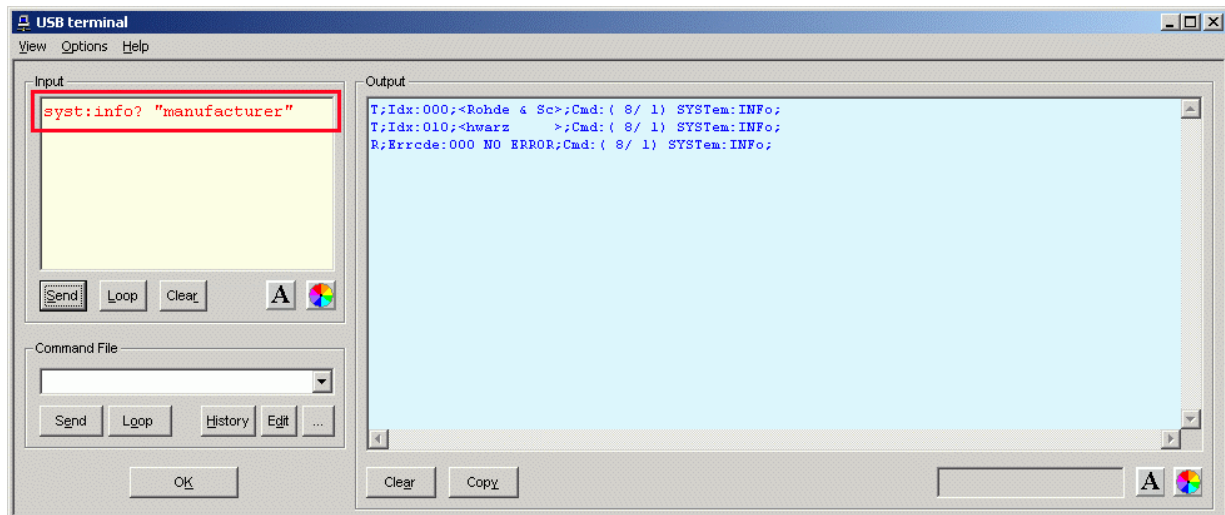

Fig. 3-1 Sending commands using the **Input** field

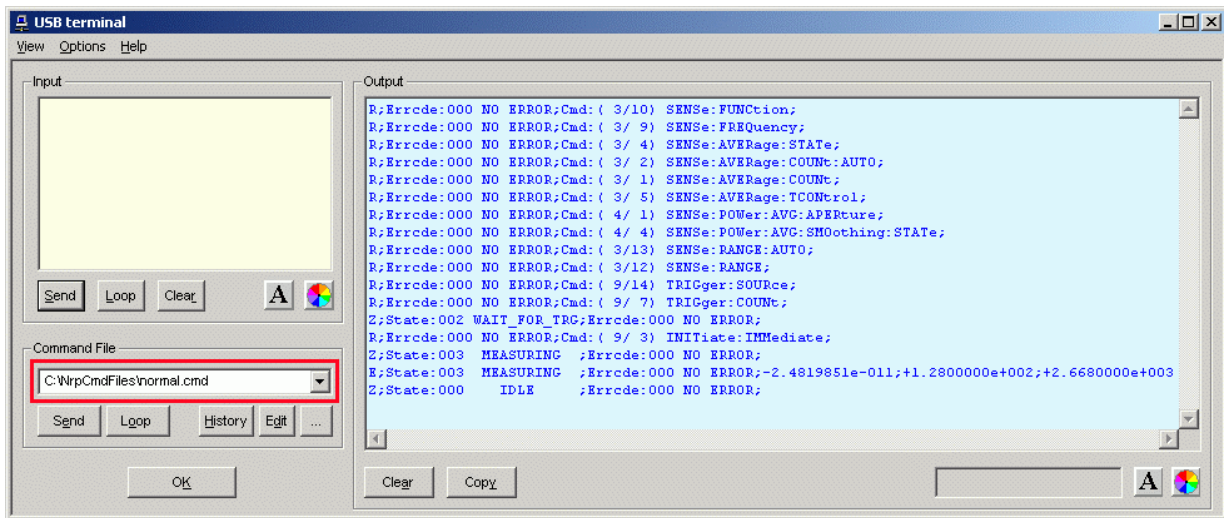

Fig. 3-2 Sending commands using command files

Table 3-1 Buttons assigned to the **Input** field

Button	Function	Key combination
Send	Sends the content of the Input entry field to the sensor.	Alt + S
Loop	With Loop the command or command sequence is cyclically sent. Pressing the button again terminates the cyclic transmission. The repetition rate is set in a dialog window that can be opened with View - Loop...	Alt + L
Clear	Clears the content of the Input field.	Alt + R
Font key	Opens a dialog window where the font for the Input field can be selected.	
Colour key	Opens a dialog window where the background colour of the Input field can be selected.	

Table 3-2 Buttons assigned to the **Command File** field

Button	Function	Key combination
Send	Sends the content of the command file to the sensor.	Alt + E
Loop	With Loop the command or command sequence is cyclically sent. Pressing the button again terminates the cyclic transmission. The repetition rate is set in a dialog window that can be opened with View - Loop...	Alt + O
History	Opens a window for editing the command file name in the Command File field.	Alt + H
Edit	Opens the selected command file in the Windows™ text editor.	Alt + D
...	Opens a file opening dialog for selecting the command file.	

A command line starting with a tab, a blank or a special character is considered a comment and not forwarded to the sensor.

Measurement results, parameters and status information returned by the sensor are displayed in the **Output** field.

Table 3-3 Buttons assigned to the **Output** field

Button	Function	Key combination
Clear	Clears the content of the Output field	Alt + A
Copy	Copies the content of the Output field to the clipboard. (Another possibility: mark the desired information in the output window with the mouse cursor, press the right mouse key or Ctrl+C and then copy the selected text to the clipboard using the menu item Copy in the opened context menu.)	Alt + Y
Font button	Opens a dialog window where the font for the Output field can be selected.	
Colour button	Opens a dialog window where the background colour of the Output field can be selected.	

Close the USB terminal with OK.

Menus

View Post Filter ... Opens the **Output Postfilter** dialog window where the lines stored in the input buffer can be filtered according to different criteria.

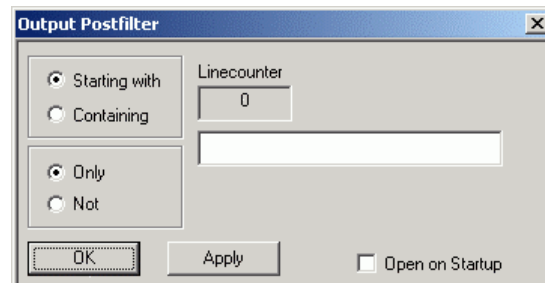

Filter criteria:

Only + Starting with: Only lines starting with the entered character string are displayed.

Not + Starting with: Only lines not starting with the entered character string are displayed.

Only + Containing: Only lines containing the entered character string are displayed.

Not + Containing: Only lines not containing the entered character string are displayed.

Lines not matching the specific filter criterion are blanked but not cleared.

Filtering is started with **Apply**. The number of lines matching the filter criterion is displayed in the **Linecounter** field. If **Open on startup** is active, the **Output Postfilter** dialog is automatically opened when the terminal is started. The dialog window is closed with **OK**.

Response Time ...

Opens the **Response time** dialog window where the response time of the sensor can be set.

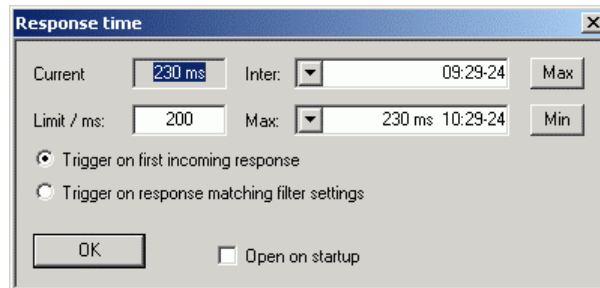

Current indicates the time elapsed between dispatch of the last command and receipt of an acknowledgement from the sensor. When the **Max** button is clicked, the response times exceeding the value in the **limit / ms** field are recorded. When the **Min** button is clicked, the response times within the value in the **limit / ms** field are recorded.

If **Trigger on first incoming response** is active, the time measurement is terminated as soon as the first response arrives after a command is sent. If **Trigger on response matching filter settings** is active, the time measurement is terminated as soon as the first response matching the filter criterion in the **Output Postfilter** dialog window is received.

If **Open on startup** is active, the **Response Time** dialog is automatically displayed when the Terminal module is started. The dialog window is closed with **OK**.

Loop ...

Opens the **Loop controls** dialog window where the cyclic transfer of commands and command sequences can be controlled.

In the **Delay / ms** field, the time interval for the cyclic transfer is specified in milliseconds.

The number of completed transfer cycles is displayed in the **Counter** field. If **Open on startup** is active, the **Response time** dialog is automatically opened when the Terminal module is started. The dialog window is closed with **OK**.

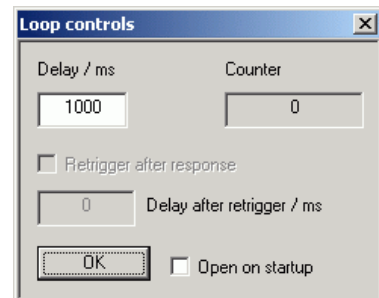

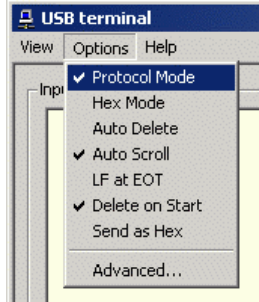
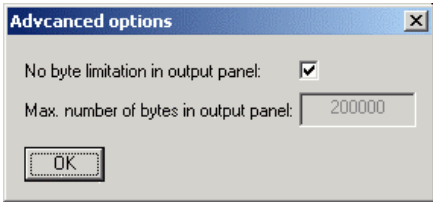
Options	Protocol Mode	In this mode, a time stamp is added to each response block.	
	Hex Mode	In this mode, the response blocks from the sensor are displayed in hexadecimal format.	
	Auto Delete	With this option active, the Output field is automatically cleared when the Send button is pressed.	
	Auto Scroll	With this option active, older items in the Output field are automatically shifted upward and off the display if space is required for new values.	
	LF at EOT	With this option active, a line feed is appended to each response block from the sensor.	
	Delete on Start	With this option active, the Output field is automatically cleared when the Terminal module is started.	
	Send as Hex	With this option active, the text in the Input field is interpreted as a hexadecimal character sequence.	
	Advanced ...	Opens a dialog window where the buffer size for the Output field can be set.	
			
			
Help	Contents	Opens the table of contents for the online help.	
	About	Displays information about the program version, etc.	

Program module "Firmware Update"

A detailed description of the program module for firmware updates is provided in the Service Manual.

Program module "Update S-Parameters"

Fundamentals

With the Sensor R&S NRP-Z11/-Z21 the influence of any twoport connected to the input on the measurement result can be corrected by way of calculation. A precondition is that a complete set of s-parameters of the twoport is available in the frequency range in question. The set of calibration data in the R&S NRP-Z11/-Z21 therefore includes an s-parameter table with up to 1000 measurement frequencies. The real and the imaginary part of each frequency as well as the uncertainty of s-parameters s_{11} , s_{12} , s_{21} and s_{22} can be stored. Since the measurement frequencies in the s-parameter table are independent of the calibration frequencies, they can be set so that the twoport frequency range of interest is optimally covered. The real and the imaginary parts between these measurement frequencies are linearly interpolated, while the more substantial measurement uncertainty at the two neighbouring frequency points is used for calculating the uncertainty of the measurement result. Below the first and above the last measurement frequency, the values of the first and the last measurement frequency are used, respectively.

The NrpFlashup program (menu item **Update S-Parameters**) is used for loading an s-parameter table. To ensure compatibility with a great number of network analyzers, NrpFlashup can process measurement data files in S2P format. All standard frequency units (Hz, kHz, MHz, GHz) and display formats (real and imaginary part, linear magnitude and phase, magnitude in dB and phase) are supported. The only restriction is that a reference impedance of $50\ \Omega$ must be used for the s-parameters. Other noise parameters in the measurement data file are not evaluated.

Structure of the S2P measurement data file:

1. The *option line* has the following format:

```
# [<frequency unit>] [<parameter>] [<format>] [<R n>]
```

identifies the *option line*.

The <frequency unit> may be Hz, kHz, MHz or GHz. If a frequency unit is not specified, GHz is implicitly assumed.

If a parameter is specified, S must be used in <parameter> for s-parameter files. If a parameter is not specified, S is implicitly assumed.

The <format> may be MA (linear magnitude and phase in degree), DB (magnitude in dB, phase in degree) or RI (real and imaginary part). If a format is not specified, MA is implicitly assumed.

R is optional and followed by the reference impedance in Ω . If an entry is made for R, R50 must be specified. If no entry is made, R50 is implicitly assumed.

The *option line* should therefore read:

```
# [HZ | KHZ | MHZ | GHZ] [S] [MA | DB | RI] [R 50]
```

2. The measurement frequencies in ascending order are specified as follows:

$$f_i \quad s_{11}(f_i) \quad s_{21}(f_i) \quad s_{12}(f_i) \quad s_{22}(f_i),$$

where $s_{jk}(f_i)$ is the specified display format for the *option line*.

$|s_{jk}(f_i)| \quad \arg s_{jk}(f_i)$ (display format for linear magnitude and phase in degree) or

$20 \cdot \lg |s_{jk}(f_i)| \quad \arg s_{jk}(f_i)$ (display format for magnitude in dB and phase in degree)

$\operatorname{Re} [s_{jk}(f_i)] \quad \operatorname{Im} [s_{jk}(f_i)]$ (display format for real and imaginary part)

3. Comments: Any line starting with an exclamation mark (!) is interpreted as a comment line.

To characterize the measurement uncertainty of the s-parameter test system, another data file can optionally be created. Without this file, the measurement uncertainty cannot be correctly calculated in the sensor. The syntax of the uncertainty data file is similar to that of the S2P data file but U is specified as <Parameter> in the *option line* so that the *option line* reads # Hz U for frequencies in Hz.

The measurement frequencies must not be identical to those of the S2P measurement data files. In most cases a few entries will be sufficient to characterize the measurement uncertainty of the s-parameter test system. An s-parameter uncertainty as high as that of the neighbouring measurement frequencies of the uncertainty data file is then selected. If different values are available, the higher one is chosen. This is illustrated in the example below:

Table 3-4 Uncertainties of the s-parameter test system (example)

f in GHz	unc [$s_{ik}(f)$]
0.1	0.01
1.0	0.01
1.1	0.005
10.0	0.005
10.1	0.01
40.0	0.01

Table 3-5 Interpolated uncertainties of measurement frequencies for s-parameters (example)

f in GHz	unc [$s_{ik}(f)$]
0.9	0.01
0.95	0.01
1.0	0.01
1.05	0.01
1.1	0.005
1.15	0.005
1.2	0.005

At 1.05 GHz, the higher uncertainty of the two adjacent 1.0 GHz and 1.1 GHz measurement frequencies is entered in the s-parameter table. If an uncertainty of 0.005 is desired for all frequencies above 1.0 GHz, the first measurement frequency in the uncertainty data file must be above 1.0 GHz, e.g. 1.000001 GHz.

Structure of the uncertainty data file:

1. The *option line* has the following format:

```
# [<frequency unit>] <parameter> [<format>] [<R n>]
# identifies the option line.
```

The <frequency unit> may be Hz, kHz, MHz or GHz. If a frequency unit is not specified, GHz is implicitly assumed.

U must be specified for <parameter> in uncertainty data files. If a parameter is not specified, S is implicitly assumed and as a result an error message is triggered.

<format> is ignored in uncertainty measurement files; the entry is therefore irrelevant.

R is optional and followed by the reference impedance in Ω . If an entry is made for R, R50 must be specified. If no entry is made, R50 is implicitly assumed.

The *option line* should therefore read:

```
# [HZ | KHZ | MHZ | GHZ] U [MA | DB | RI] [R 50]
```

2. Measurement frequencies in ascending order are specified in the following form:

$$f_i \text{ unc } [s_{11}(f_i)] \text{ unc } [s_{21}(f_i)] \text{ unc } [s_{12}(f_i)] \text{ unc } [s_{22}(f_i)].$$

The s-parameters uncertainties are forwarded as follows:

- as extended absolute uncertainties ($k = 2$) for the magnitude of reflection parameters s_{11} and s_{22} , for instance 0.015,
- as extended uncertainties ($k = 2$) in dB for the magnitude of transmission parameters s_{21} and s_{12} , for instance 0.015.

3. Comments: Any line starting with an exclamation mark (!) is interpreted as a comment line.

Two additional values must be specified when the s-parameters are loaded: the lower and the upper nominal measurement limit of the sensor-twoport combination. If s-parameter correction is active, these values are transferred by the sensor in response to SYSTem:INFO? The values cannot always be derived from the lower or upper measurement limit of the sensor alone and from the loss or gain of the preconnected twoport. The upper measurement limit of the sensor-twoport combination may also be limited by the twoport's maximum power-handling capacity. Furthermore, the lower measurement limit may be raised not only by the loss but also by the inherent noise of the twoport. For this reason, NrpFlash allows these values to be entered.



The upper nominal measurement limit of the sensor-twoport combination entered when loading the s-parameters should be carefully specified, as automatic test systems may evaluate it and an incorrect value may cause the sensor and/or the twoport to be overloaded.

Procedure

To load an s-parameter table into the calibration set of the sensor, proceed as follows:

1. Connect the sensor to the USB port of the PC and start NrpFlashup.
2. Activate **Update S-Parameters** in the menu. The corresponding dialog window is opened (Fig. 3-3).
3. Under **S-Parameter File** enter the search path and the name of the S2P file containing the parameters. Press the **Browse...** button to open a file-opening dialog where the S2P measurement data file can be easily selected.
4. Under **Uncertainty File** enter the search path and the name of the measurement uncertainty file containing the measurement uncertainty of the s-parameter test system. Press the **Browse...** button to open a file-opening dialog where the measurement uncertainty file can be easily selected.
5. Enter the upper and lower nominal measurement limit of the sensor-twoport combination in the **Lower Power Limit** and **Upper Power Limit** fields.
6. Enter a name for the loaded s-parameter set in the **S-Parameter Device Mnemonic** field. This name can later be queried with `SYSTem:INFO? "SPD Mnemonic"` and is displayed on the NRP basic unit when s-parameter correction is switched on.
7. Activate **S-Parameter Correction on by Default** if the `SENSe:CORRection:TRANsmission` switch should be automatically set to `ON` when the sensor is put into operation.
8. Press **Start** for loading. (The dialog is closed with **OK** and the set parameters are retained. When the dialog is exited with **Cancel**, all parameter modifications are ignored.)

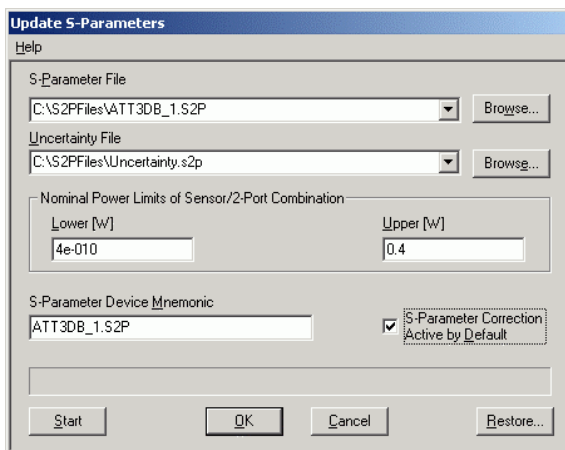

Fig. 3-3 Dialog window for loading an s-parameter table

During loading, the current calibration data set of the sensor is overwritten. To be on the safe side, a backup copy of the current calibration data set is therefore automatically stored before s-parameters are loaded. The names of the backup files have the structure <batch number>_<date><time>.bak, where <batch number> is the batch number of the sensor, <date> the date of the s-parameter update in yymmdd format and <time> the time of the s-parameter update in the format hhmmss.



Store the automatically created backup files on a separate data medium (e.g. diskette, CD-ROM or network drive) and, if required, assign a meaningful name to them to simplify reloading. With the aid of these files, a previously used calibration data set of the sensor can be restored.

To reload the backup file of a calibration data set into the sensor, proceed as follows:

- Press the **Restore...** button. The **Restore S-Parameters** window is opened (Fig. 3-4).
- Enter the search path and the name of the backup file in the **Backup File** field. Press the **Browse...** button to open a dialog where the backup file can be easily selected.
- Press **OK** to start the restore procedure. (With **Cancel** the dialog window is exited without data being restored).

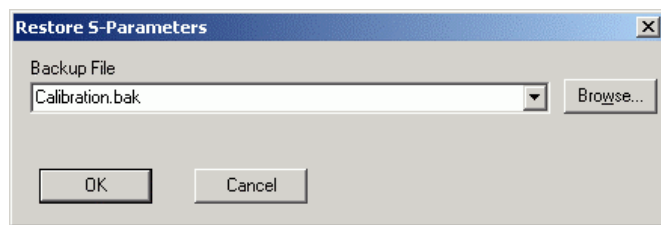

Fig. 3-4 Dialog window for loading the backup file of a calibration data set

Table of Contents

5 Remote Control – Fundamentals 5.1

5 Remote Control – Fundamentals

Rohde & Schwarz recommends to utilize the VXI Plug & Play Driver for the remote control of R&S NRP power sensors. This driver can be found on the CD-ROM supplied with the sensor or downloaded in its most recent version via the internet (<http://rohde-schwarz.com/>).

The old remote control interface provided by the *Dynamic Link Library NrpControl.dll* is not developed further, but remains on the CD-ROM and can be downloaded via the internet.

Table of Contents

6 Remote Control – Commands	6.1
Notation	6.1
Commands as per IEEE 488.2	6.2
*IDN? – IDentification Query	6.2
*RST – Reset	6.2
*TRG – Trigger	6.2
*TST? – Self Test Query	6.2
SCPI Commands	6.3
CALibration	6.3
CALibration:DATA[?] <calibration data set as <i>definite length block</i> >	6.3
CALibration:DATA:LENGth?	6.3
CALibration:ZERO:AUTO[?] OFF ON ONCE	6.4
SENSe (Sensor Configuration)	6.5
SENSe:AVERAge:COUNt[?] 1 to 65536	6.7
SENSe:AVERAge:COUNt:AUTO[?] OFF ON ONCE	6.7
SENSe:AVERAge:COUNt:AUTO:MTIME[?] 1.0 to 999.99	6.8
SENSe:AVERAge:COUNt:AUTO:NSRatio[?] 0.0001 to 1.0	6.8
SENSe:AVERAge:COUNt:AUTO:RESolution[?] 1 to 4	6.8
SENSe:AVERAge:COUNt:AUTO:SLOT[?] 1 to <SENSe:POWEr:TSLot:AVG:COUNt>	6.8
SENSe:AVERAge:COUNt:AUTO:TYPE[?] RESolution NSRatio	6.9
SENSe:AVERAge:RESet	6.9
SENSe:AVERAge:STATe[?] OFF ON	6.9
SENSe:AVERAge:TCONtrol[?] MOVing REPEAT	6.9
SENSe:CORRection:DCYClE[?] 0.001 to 99.999	6.10
SENSe:CORRection:DCYClE:STATe[?] OFF ON	6.10
SENSe:CORRection:OFFSet[?] –200.0 to 200.0	6.10
SENSe:CORRection:OFFSet:STATe[?] OFF ON	6.10
SENSe:CORRection:SPDev:STATe[?] OFF ON	6.11
SENSe:FREQUency[?] 10.0e6 to 8.0e9 (NRP-Z11) or 18.0e9 (NRP-Z21)	6.11
SENSe:FUNcTION[?] <sensor_function>	6.12
SENSe:POWEr:AVG:APERture[?] 0.0001 to 0.3	6.13
SENSe:POWEr:AVG:BUFFer:SIZE[?] 1 to 1024	6.13
SENSe:POWEr:AVG:BUFFer:STATe[?] OFF ON	6.14
SENSe:POWEr:AVG:SMOothing:STATe[?] OFF ON	6.14
SENSe:POWEr:BURSt:DTOLerance[?] 0.0 to 0.003	6.14
SENSe:POWEr:TSLot:AVG:COUNt[?] 1 to 128	6.15
SENSe:POWEr:TSLot:AVG:WIDTh[?] 0.0001 to 0.1	6.15
SENSe:RANGe[?] 0 to 2	6.15
SENSe:RANGe:AUTO[?] OFF ON	6.16
SENSe:RANGe:AUTO:CLEVel[?] –20.0 to 0.0	6.16
SENSe:SAMPLing[?] FREQ1 FREQ2	6.16
SENSe:SGAMma:CORRection:STATe[?] OFF ON	6.16
SENSe:SGAMma:MAGNitude[?] 0.0 to 1.0	6.17

SENSe:SGAMma:PHASe[?] -360.0 to 360.0.....	6.17
SENSe:TRACe:AVERAge:COUNt[?] 1 to 65536.....	6.17
SENSe:TRACe:AVERAge:COUNt:AUTO[?] OFF ON ONCE.....	6.17
SENSe:TRACe:AVERAge:COUNt:AUTO:MTIME[?] 1.0 to 999.99.....	6.18
SENSe:TRACe:AVERAge:COUNt:AUTO:NSRatio[?] 0.0001 to 1.0.....	6.18
SENSe:TRACe:AVERAge:COUNt:AUTO:RESolution[?] 1 to 4.....	6.18
SENSe:TRACe:AVERAge:COUNt:AUTO:POINt[?] 1 to <SENSe:TRACe:POINts>..	6.18
SENSe:TRACe:AVERAge:COUNt:AUTO:TYPE[?] RESolution NSRatio.....	6.19
SENSe:TRACe:AVERAge:STATe[?] OFF ON.....	6.19
SENSe:TRACe:AVERAge:TCONtrol[?] MOVing REPeat.....	6.19
SENSe:TRACe:MPWidth?.....	6.19
SENSe:TRACe:OFFSet:TIME[?] - (<TRIGger:DELay> + 0.005) to 100.0.....	6.20
SENSe:TRACe:POINts[?] 1 to 1024.....	6.20
SENSe:TRACe:REALtime[?] OFF ON.....	6.20
SENSe:TRACe:TIME[?] 0.0001 to 0.3.....	6.20
SENSe:TIMing:EXCLude:STARt[?] 0.0 to 0.1.....	6.20
SENSe:TIMing:EXCLude:STOP[?] 0.0 to 0.003.....	6.21
SYSTem.....	6.22
SYSTem:INFO? [Item].....	6.22
SYSTem:INITialize.....	6.23
SYSTem:MINPower?.....	6.24
SYSTem:TRANsaction:BEgIn.....	6.24
SYSTem:TRANsaction:END.....	6.24
TEST.....	6.25
TEST:SENSor?.....	6.25
TRIGger.....	6.26
ABORt.....	6.26
INITiate:CONTInuous[?] OFF ON.....	6.26
INITiate:IMMediate.....	6.27
TRIGger:ATRigger:STATe[?] OFF ON.....	6.27
TRIGger:COUNt[?] 1 to 2×10^9	6.27
TRIGger:DELay[?] x to 100.0.....	6.28
TRIGger:DELay:AUTO[?] OFF ON.....	6.28
TRIGger:HOLDoff[?] 0.0 to 10.0.....	6.28
TRIGger:HYSTeresis[?] 0.0 to 10.0.....	6.28
TRIGger:IMMediate.....	6.28
TRIGger:LEVel[?] x to y.....	6.29
TRIGger:SLOPe[?] POSitive NEGative.....	6.29
TRIGger:SOURce[?] BUS EXTernal HOLD IMMediate INTernal.....	6.29
List of Remote-Control Commands	6.30

Figs.

Fig. 6-1 Effect of SENSE:POWER:BURSt:DTOLerance..... 6.15
 Fig. 6-2 Effect of SENSE:TIMing:EXCLude:STARt and :END in the *Burst Average* mode..... 6.21
 Fig. 6-3 Effect of SENSE:TIMing:EXCLude:STARt and :END in the *Timeslot* mode..... 6.21

Tables

Table 6-1 Commands of the *CALibration* system..... 6.3
 Table 6-2 Commands of the *SENSe* system..... 6.5
 Table 6-3 Measurement modes..... 6.12
 Table 6-4 Optimum selection of the sampling window size (N = 1, 2, 3, ...)..... 6.13
 Table 6-5 Commands of the *SYSTem* system 6.22
 Table 6-6 Meaning of *Item* in the *SYSTem:INFO?* command..... 6.22
 Table 6-7 Commands of the *TEST* system 6.25
 Table 6-8 Commands of the *TRIGger* system..... 6.26
 Table 6-9 List of remote-control commands..... 6.30

6 Remote Control – Commands

Notation

In the following sections, all commands implemented in the sensor are first listed in a table according to command systems and are then described in detail. The notation is largely in line with the SCPI standard.

Command tables For a quick overview of available commands, the commands are listed in a table before they are described. These tables contain the following four columns:

Command:	Commands and their tree structure.
Parameters:	Possible parameters.
Unit:	The basic unit of the physical parameters (must not be sent with parameters).
Remarks:	Identification of all commands <ul style="list-style-type: none"> • that have no query form • that are available as query only

Indentations The various levels of the SCPI command hierarchy are shown in the table by indentations to the right. The lower the level, the greater the indentation to the right. It should be noted that the complete notation of the command includes the higher levels too.

Example:

SENSe:AVERAge:COUNt is represented in the table as follows:

```
SENSe      first level
  :AVERAge  second level
    :COUNt  third level
```

In the individual description, the command is shown in full length. An example of the command is given at the end of the description.

[?]
?

A question mark in square brackets at the end of a command indicates that this command can either be used as a setting command (without question mark) or as a query (with question mark). If the question mark is not in square brackets, the command is a query only.

Example:

SENSe:POWer:AVG:APERture[?]

SENSe:POWer:AVG:APERture 1e-3 sets the length of the sampling window to 1 ms.

SENSe:POWer:AVG:APERture? Returns the currently set length as a response.

**IDN?* Queries the sensor identification string that of course cannot be changed. For this reason, this command is only available as a query.

Special characters | for parameters

A vertical bar between parameters is used to separate alternative options (OR link).

Example:

NIITate:CONTInuous OFF | ON

The parameter *OFF* or *ON* can be entered.

{numeric expression}

A numeric expression in braces means that it has been rounded to the nearest integral value.

**<parameter>
<variable>**

A parameter or a variable in triangular brackets expresses its current value.

Commands as per IEEE 488.2

The sensor supports a subset of the possible setting commands and queries (*Common Commands and Queries*) in line with IEEE 488.2.

*IDN? – Identification Query

*IDN? returns a string with information on the sensor's identity (device identification code). In addition, the version number of the installed firmware is indicated. The string for a sensor of type R&S NRP-Z21 has the following structure:

ROHDE&SCHWARZ,NRP-Z21,<serial number>,<firmware version>

<serial number>: Serial number in ASCII

<firmware version>: Firmware version number in ASCII

*RST – Reset

*RST sets the sensor to the default state, i.e. the default settings for all test parameters are loaded.

*TRG – Trigger

*TRG triggers a measurement. For this purpose, the sensor is in the *WAIT_FOR_TRIGGER* state and the source for the trigger event is set to *BUS (TRIGger:SOURce BUS)*.

*TST? – Self Test Query

*TST? starts a selftest and returns 0 (no error found) or 1 (an error has occurred). The selftest comprises the following functions:

- RAM test
- Operating voltages
- Temperature measurement
- Calibration data set
- Noise
- Zero-point offsets.

SCPI Commands

The sensors R&S NRP-Z11/-Z21 are controlled via the groups of commands

- CALibration (zeroing)
- SENSE (measurement configurations)
- SYSTem
- TRIGger
- SERViCe.

CALibration

Table 6-1 Commands of the *CALibration* system

Command	Parameter	Unit	Remarks
CALibration			
:DATA[?]	<calibration data set as definite length block>		
:LENGth?		Bytes	Query only
:ZERO			
:AUTO[?]	OFF ON ONCE		

CALibration:DATA[?] <calibration data set as *definite length block*>

CALibration:DATA is used for writing a calibration data set in the flash memory of the sensor.

The query yields the calibration data set currently stored in the flash memory as a *definite length block*.

CALibration:DATA:LENGth?

CALibration:DATA:LENGth? yields the length in bytes of the calibration data set currently stored in the flash memory. Programs that read out the calibration data set can use this information to determine the capacity of the buffer memory required.

CALibration:ZERO:AUTO[?] OFF | ON | ONCE

The commands *CALibration:ZERO:AUTO ON* and *CALibration:ZERO:AUTO ONCE* zeroes the three measurement paths of the sensor. For this purpose, the test signal must be deactivated or the sensor disconnected from the signal source. The sensor automatically detects the presence of any significant power to be measured. This causes zeroing to be aborted and error message *NRPEROR_CALZERO* to be output. The *CALibration:ZERO:AUTO OFF* is ignored. Zeroing takes four seconds at a minimum, but at least as long as the selected averaging filter needs for settling (only fixed-filter mode).



Repeat zeroing

- *during warm-up after switching on or connecting the instrument*
- *after a substantial variation of the ambient temperature*
- *after fastening the sensor to an RF connector at high temperature*
- *after several hours of operation*
- *when very low-power signals are to be measured, e.g. less than 10 dB above the lower measurement limit.*

For zeroing switch off the test signal and do not remove the sensor from the signal source. Apart from keeping the thermal balance, this has the advantage that the noise superimposed on the test signal (e.g. from a broadband amplifier) can be detected on zeroing and does not impair the measurement result.

The query always yields 1 (= OFF).

Default setting

After a power-on reset, the zero offsets determined during the last calibration are used until the first zeroing. Therefore, very slight zero offsets are to be expected with a warmed up sensor. Initialization by means of **RST* or *SYSTem:INITialize* has no influence on the current zero offsets.

SENSe (Sensor Configuration)

The sensor is configured by means of the commands of the groups *SENSe* and *TRIGger*.

Table 6-2 Commands of the *SENSe* system

Command	Parameter	Unit	Remarks
SENSe			
:AVERage			
:RESet			No query
:STATe[?]	OFF ON		
:TCONtrol[?]	MOVing REPeat		
:COUNt[?]	1 to 65536		
:AUTO[?]	OFF ON ONCE		
:TYPE[?]	RESolution NSRatio		
:MTIME[?]	1.0 to 999.99	s	
:NSRatio[?]	0.0001 to 1.0	dB	
:RESolution[?]	1 to 4		
:SLOT[?]	1 to <SENSe:POWer:TSLot:AVG:COUNt>		
:CORRection			
:OFFSet[?]	-200.0 to 200.0	dB	
:STATe[?]	OFF to ON		
:DCYClE[?]	0.001 to 99.999	%	
:STATe[?]	OFF to ON		
:SPDevice:STATe[?]	OFF to ON		
:FREQUency[?]	10.0e6 to 8.0e9 (NRP-Z11) or 18.0e9 (NRP-Z21)	Hz	
:FUNction[?]	"POWer:AVG" "POWer:TSLot:AVG" "POWer:BURSt:AVG" "XTIME:POWer"		
:POWer			
:AVG			
:APERture[?]	1.0e-6 to 0.3	s	
:BUFFer			
:STATe[?]	OFF ON		
:SIZE[?]	1 to 1024		

Command	Parameter	Unit	Remarks
:SMOothing:STATe[?]	OFF ON		
:BURSt:DTOLerance[?]	0.0 to 3.0e-3	s	
:TSLot:AVG			
:COUNt[?]	1 to 128		
:WIDTh[?]	10e-6 to 100e-3	s	
:RANGe [?]	0 to 2		
:AUTO[?]	OFF ON		
:CLEVel[?]	0.0 to 20.0	dB	
:SAMPLing[?]	FREQ1 FREQ2		
:SGAMma			
:CORRection:STATe[?]	OFF ON		
:MAGNitude[?]	0.0 to 1.0		
:PHASe[?]	-360.0 to 360.0	degree	
:TRACe			
:AVERage			
:STATe[?]	OFF ON		
:TCONtrol[?]	MOVing REPeat		
:COUNt[?]	1 to 65536		
:AUTO[?]	OFF ON ONCE		
TYPE[?]	RESolution NSRatio		
:MTIME[?]	1.0 to 999.99	s	
:NSRatio[?]	0.0001 to 1.0	dB	
:RESolution[?]	1 to 4		
:POINt[?]	1 to <SENSe:TRACe:POINts>		
:MPWidth?		s	Query only
:OFFSet:TIME[?]	- (<TRIGger:DELay> + 0.005) to 100.0	s	
:POINts[?]	1 to 1024		
:REALtime[?]	OFF ON		

Command	Parameter	Unit	Remarks
:TIME[?]	0.0001 to 0.3		
:TIMing			
:EXCLude			
:STARt[?]	0.0 to 3.0e-3	s	
:STOP[?]	0.0 to 3.0e-3	s	

SENSe:AVERage:COUNT[?] 1 to 65536

SENSe:AVERage:COUNT sets the number of measured values that have to be averaged for forming the measurement result in the modes *Continuous Average*, *Burst Average* and *Timeslot*. The higher this averaging factor, the less the measured values fluctuate and the longer the measurement time lasts. The parameter is rounded off to the nearest power-of-two number.

The query yields the averaging factor used in the modes *Continuous Average*, *Burst Average* and *Timeslot*.



The averaging function must be activated with SENSe:AVERage:STATe ON so that the set averaging factor becomes effective.

Default setting: 4

SENSe:AVERage:COUNT:AUTO[?] OFF | ON | ONCE

SENSe:AVERage:COUNT:AUTO activates (auto-averaging) or deactivates (fixed-filter mode) automatic determination of the averaging factor in the modes *Continuous Average*, *Burst Average* and *Timeslot*. If auto-averaging is activated, the averaging factor is continuously determined and set depending on the level of power and other parameters.

SENSe:AVERage:COUNT:AUTO ON activates auto-averaging and *SENSe:AVERage:COUNT:AUTO OFF* deactivates it. On deactivation, the previous, automatically determined averaging factor is used in the fixed-filter mode. The *SENSe:AVERage:COUNT:AUTO ONCE* command ensures that a new averaging factor is determined by the filter automatic function under the current measurement conditions and used in the fixed-filter mode.

The query yields

- 1 for *OFF*,
- 2 for *ON*.

Default setting: *OFF*

SENSe:AVERAge:COUNT:AUTO:MTIME[?] 1.0 to 999.99

SENSe:AVERAge:COUNT:AUTO:MTIME sets the settling time upper limit of the averaging filter in the auto-averaging mode for the *Continuous Average*, *Burst Average* and *Timeslot* modes and limits the length of the filter.

The query yields the current settling time upper limit of the averaging filter in the auto-averaging mode for the *Continuous Average*, *Burst Average* and *Timeslot* modes.

Default setting: 30.0 [s]

SENSe:AVERAge:COUNT:AUTO:NSRatio[?] 0.0001 to 1.0

SENSe:AVERAge:COUNT:AUTO:NSRatio determines the relative noise component in the measurement result for the *Continuous Average*, *Burst Average* and *Timeslot* modes if auto-averaging is operated in the corresponding mode (*SENSe:AVERAge:COUNT:AUTO:TYPE NSRatio*). The noise component is defined as the magnitude of the level variation in dB caused by the inherent noise of the sensor (two standard deviations).

The query yields the relative noise component in the result for the *Continuous Average*, *Burst Average* or *Timeslot* modes.

Default setting: 0.01 [dB]

SENSe:AVERAge:COUNT:AUTO:RESolution[?] 1 to 4

SENSe:AVERAge:COUNT:AUTO:RESolution sets the resolution index for the automatic averaging filter in the *Continuous Average*, *Burst Average* and *Timeslot* modes if it is operated in the *RESolution* mode. The resolution index equals the number of decimal places that have to be taken into account for the further processing of the measurement result in dBm, dB μ V or dB. The normal mode is designed in a similar manner as for the predecessors R&S NRVS and R&S NRVD or other commercial power meters. The higher the selected index, the better the measurement result is filtered without the last significant place (0.01 dB with an index of 3) actually being set. The *NSRatio* setting is recommended instead.

The query yields the resolution index for the *Continuous Average*, *Burst Average* and *Timeslot* modes.

Default setting: 3

SENSe:AVERAge:COUNT:AUTO:SLOT[?] 1 to <SENSe:POWer:TSLot:AVG:COUNT>

SENSe:AVERAge:COUNT:AUTO:SLOT defines the timeslot, whose power is referenced by auto-averaging in the *Timeslot* mode. The timeslot is addressed via its number, the counting beginning with 1. The timeslot number must not exceed the number of the currently set timeslots. If a valid timeslot number is initially set and then the number of timeslots reduced to a value that is smaller than the initial timeslot number, the initial value is automatically set to the new timeslot number, i.e. auto-averaging references the most recent timeslot.

The query yields the number of the current timeslot, whose power is referenced by auto-averaging in the *Timeslot* mode.

Default setting: 1

SENSe:AVERage:COUNt:AUTO:TYPE[?] RESolution | NSRatio

SENSe:AVERage:COUNt:AUTO:TYPE defines the automatic averaging filter mode in the *Continuous Average*, *Burst Average* and *Timeslot* modes. The *RESolution* parameter sets the mode usual for power meters; *NSRatio* predefines the compliance to an exactly defined noise component.

The query yields

- 1 for *RESolution*,
- 2 for *NSRatio*.

Default setting: *RESolution*

SENSe:AVERage:RESet

SENSe:AVERage:RESet initializes the averaging filter for the *Continuous Average*, *Burst Average* or *Timeslot* modes. This is useful if a high averaging factor is set in the *SENSe:AVERage:TCONtrol MOVing* filter mode and if the power to be measured has significantly decreased since the previous measurement, e.g. by several powers of ten. In this case, previous measurement results still contained in the averaging filter strongly affect the settling of the display; as a result, the advantage of the *SENSe:AVERage:TCONtrol MOVing* filter mode, i.e. the ability to detect trends in the measurement result while the measurement is still in progress, is lost. The *SENSe:AVERage:RESet* command solves this problem by deleting all previous measurement results that the averaging filter contains. After initialization, the filter length gradually increases from 1 to its nominal value *SENSe:AVERage:COUNt*, so that trends in the measurement result become quickly apparent. However, this procedure does not shorten the measurement time required in order for the averaging filter to settle completely.

SENSe:AVERage:STATe[?] OFF | ON

SENSe:AVERage:STATe switches on or off the averaging filter for the *Continuous Average*, *Burst Average* and *Timeslot* modes.

The query yields

- 1 for *OFF*,
- 2 for *ON*.

Default setting: *ON*

SENSe:AVERage:TCONtrol[?] MOVing | REPeat

SENSe:AVERage:TCONtrol (*terminal control*) defines the behaviour of the averaging filter in the *Continuous Average*, *Burst Average* and *Timeslot* modes. As soon as a new measured value is shifted to the FIR filter, a new average value is available at the filter output, which is obtained from the new measured value and the other values stored in the filter.

The *MOVing* parameter defines that each new average value is output as a measurement result. This allows tendencies in the result to be recognized during the measurement procedure.

The *REPeat* parameter defines that a new result is output after the FIR filter has been filled with new measured values. This ensures that no redundant information is output.

The query yields

- 1 for *MOVing*,
- 2 for *REPeat*.

Default setting: *MOVing*

SENSe:CORRection:DCYClE[?] 0.001 to 99.999

SENSe:CORRection:DCYClE sets the duty cycle to a percent value for the correction of pulse-modulated signals. With the correction activated, the sensor calculates the signal pulse power from this value and the mean power. Since the duty cycle is only useful in the Continuous Average mode and the normal mode, it is evaluated only there.

The query yields the current duty cycle in percent.

Default setting: 1.0 [%]

SENSe:CORRection:DCYClE:STATe[?] OFF | ON

SENSe:CORRection:DCYClE:STATe ON activates the duty cycle correction and thus the pulse-power measurement whereas *SENSe:CORRection:DCYClE:STATe OFF* deactivates it.

The query yields

- 1 for OFF,
- 2 for ON.

Default setting: OFF

SENSe:CORRection:OFFSet[?] -200.0 to 200.0

SENSe:CORRection:OFFSet defines a fixed offset in dB, which is used to correct the measured value. (When a log scale is used, the offset is added to the measured value; this is the reason why the command has this name.)

The attenuation of an attenuator located ahead of the sensor or the coupling attenuation of a directional coupler is taken into account with a positive offset, i.e. the sensor calculates the power at the input of the attenuator or directional coupler. A negative offset can be used to correct the influence of a gain connected ahead.

The query yields the set offset in dB.

Default setting: 0.0 [dB]

SENSe:CORRection:OFFSet:STATe[?] OFF | ON

SENSe:CORRection:OFFSet:STATe ON activates the offset correction and *SENSe:CORRection:OFFSet:STATe OFF* deactivates it.

The query yields

- 1 for OFF,
- 2 for ON.

Default setting: OFF

SENSe:CORRection:SPDev:STATe[?] OFF | ON

SENSe:CORRection:SPDevice:STATe ON activates the s-parameter data set for a component (attenuator, directional coupler) connected ahead of the sensor. Parameter *OFF* deactivates it.

The use of s-parameters instead of a fixed offset

(see group of commands *SENSe:CORRection:OFFSet*)

allows more precise measurements, since the interactions between the sensor, the source and components connected between them can be taken into account. (For detailed information on loading s-parameter data sets, refer to section 3.) The sensor has no factory-set s-parameter data set. In this state, the *SENSe:CORRection:SPDevice:STATe ON* command generates an error message.

The query yields

- 1 for *OFF*,
- 2 for *ON*.

Default setting:

The factory-set default setting of the sensor is *OFF*. On loading an s-parameter table, the default setting can be redefined (see section 3).

SENSe:FREQuency[?] 10.0e6 to 8.0e9 (NRP-Z11) or 18.0e9 (NRP-Z21)

SENSe:FREQuency transfers the carrier frequency of the RF signal to be measured; this frequency is used for the frequency-response correction of the measurement result. The center frequency is set for broadband signals (*spread-spectrum* signals, multicarrier signals).

The query yields the set carrier frequency in Hz.

Default setting: *50.0e6 [Hz]*

SENSe:FUNcTion[?] <sensor_function>

SENSe:FUNcTion <sensor_function> sets the sensor to one of the following measurement modes:

Table 6-3 Measurement modes

<sensor_function>	Description of the measurement mode
"POWer:AVG"	<p>Continuous Average After occurrence of the trigger event, the mean power is measured in a time interval (sampling window) whose width is defined with SENSE:POWer:AVG:APERTure. The single measurements are performed in pairs to obtain a more accurate measurement result by differentiation. With the averaging function activated, this operation is repeated the number of times specified by the averaging factor. With the averaging function activated, the actual measurement time is thus $2 \times \langle \text{SENSe:AVERAge:COUNT} \rangle \times \langle \text{SENSe:POWer:AVG:APERTure} \rangle$ and with deactivated averaging function $2 \times \langle \text{SENSe:POWer:AVG:APERTure} \rangle$. Trigger events start one or several measurements in the Continuous Average mode (depending on the TRIGger:COUNT parameter).</p>
"POWer:TSLot:AVG"	<p>Timeslot The power is measured in a defined number of consecutive timeslots. Up to 128 timeslots have the same width, which is defined by SENSE:POWer:TSLot:WIDTH. Their quantity is defined by SENSE:POWer:TSLot:COUNT. The measurement result is an array, which contains as many elements as timeslots. Each element represents the average power in one of the timeslots. After each occurrence of the trigger event, a measurement is performed in all timeslots. The single measurements are also performed in pairs in this mode to obtain a more accurate measurement result by differentiation. With the averaging function activated, this operation is repeated the number of times specified by the averaging factor. With the averaging function activated, the actual measurement time is thus $2 \times \langle \text{SENSe:AVERAge:COUNT} \rangle \times \langle \text{SENSe:POWer:TSLot:AVG:WIDTH} \rangle$ and with deactivated averaging function $2 \times \langle \text{SENSe:POWer:TSLot:AVG:WIDTH} \rangle$. Note that a corresponding number of trigger events must be available.</p>
"POWer:BURSt:AVG"	<p>Burst Average This mode is used for the measurement of the average power of repetitive single bursts, for example. The time interval (integration time) in which the average power is measured is not predefined. Instead, a special algorithm detects the beginning and end of the burst and ensures the synchronization of the sampling window. However, the user must define the dropout tolerance, a time criterion for detecting the pulse or burst end, using SENSE:POWer:BURSt:DTOLerance. In the Burst Average mode, external trigger events (irrespective of the setting of the TRIGger:SOURce parameter) and the TRIGger:DELay parameter are ignored.</p>
"XTIME:POWer"	<p>Scope The Scope mode is similar to the Timeslot mode. Since, however, up to 1024 consecutive timeslots (called "points" here) are possible, the maximum averaging factor is limited to 8192 due to the storage capacity. In the Scope mode, other limits than in the Timeslot mode apply to the timeslot width. SENSE:TRACe:REALtime ON optimizes the time resolution. The differentiation and averaging filter are ignored.</p>

Time intervals that are excluded from the measurement can be set at the beginning and the end of the sampling window or timeslot in the measurement modes *Burst Average* and *Timeslot*. (*SENSe:TIMing:EXCLude:START* and *-:STOP*).

The query yields

- 1 for "POWer:AVG",
- 2 for "POWer:TSLot:AVG",
- 4 for "POWer:BURSt:AVG",
- 8 for "XTIME:POWer".

Default setting: "POWer:AVG"

SENSe:POWer:AVG:APERture[?] 0.0001 to 0.3

SENSe:POWer:AVG:APERture defines the time interval (sampling window) for the *Continuous Average* mode; measured values are continuously recorded in this interval. In manual operation, the default setting of 20 ms in conjunction with the activated smoothing (see *SENSe:POWer:AVG:SMOothing:STATE*) is sufficient in most cases. Another value, which is normally higher, is required when the measurement result shows variations due to modulation. Especially with low-frequency modulation, it is useful to adapt the size of the sampling window exactly to the modulation period, which yields an optimum stable display.

Table 6-4 Optimum selection of the sampling window size (N = 1, 2, 3, ...)

Smoothing	Optimum sampling window size
OFF	$N \times \text{modulation period} / 2$
ON	$N \times \text{modulation period} \times 2$

The theoretically shortest measurement time can then be obtained only with smoothing deactivated. As the number of modulation periods that fit into a sampling window increases, the issue of whether N is an integer becomes more critical. With smoothing activated, approx. 5 periods are sufficient to reduce variations due to modulation to an acceptable extent; variations are no longer perceptible with more than 9 periods. With smoothing deactivated, the situation is significantly unfavourable. In this case, 5 instead of 300 periods are required and the variations completely disappear as of 3000 periods.

The query yields the currently set width of the sampling window in seconds.

Default setting: 0.02 [s]

SENSe:POWer:AVG:BUFFer:SIZE[?] 1 to 1024

SENSe:POWer:AVG:BUFFer:SIZE sets the buffer size for the buffered *Continuous Average* mode.

The query yields the current buffer size for the buffered *Continuous Average* mode.

Default setting: 1

SENSe:POWer:AVG:BUFFer:STATe[?] OFF | ON

The buffered *Continuous Average* mode is activated with *ON* and deactivated with *OFF*. In this mode, the results generated by trigger events are collected in the sensor until the buffer is filled. All results are then transferred as block data. The measurement rate obtained is thus higher than in the non-buffered *Continuous Average* mode. The maximum measurement rate is obtained by combining the buffered mode with multiple triggering (see parameter *TRIGger:COUNt*). The size of the result buffer is set with the *SENSe:POWer:AVG:BUFFer:SIZE* command.

The query yields

- 1 for *OFF*,
- 2 for *ON*.

Default setting: *OFF*

SENSe:POWer:AVG:SMOothing:STATe[?] OFF | ON

The *ON* parameter activates a smoothing filter for modulated signals in the *Continuous Average* mode and *OFF* deactivates it. The smoothing filter is a steep-edge digital lowpass filter used to suppress variations of results caused by low-frequency modulation. This parameter should be activated to reduce variations in results due to modulation when the size of the sampling window cannot or should not be exactly adapted to the modulation period. If the selected sampling window is 5 to 9 times larger than a modulation period, the variations in display are normally sufficiently reduced. With smoothing deactivated, 300 to 3000 periods are required to obtain the same effect.

With smoothing deactivated, the sampling values are considered equivalent and averaged in a sampling window, which yields an integrating behaviour of the measuring instrument. As described above, optimum suppression of variations in the result is thus obtained when the size of the sampling window is exactly adapted to the modulation period. Otherwise, the modulation can have a considerable influence, even if the sampling window is much larger than the modulation period. The behaviour can be considerably improved by subjecting sampling values to weighting (raised-von-Hann window), which corresponds to video filtering. This is exactly what happens with activated smoothing.

Since the smoothing filter increases the inherent noise of the sensor by approx. 20%, it should remain deactivated if it is not required.

The query yields

- 1 for *OFF*,
- 2 for *ON*.

Default setting: *ON*

SENSe:POWer:BURSt:DTOLerance[?] 0.0 to 0.003

SENSe:POWer:BURSt:DTOLerance defines the dropout tolerance, a parameter for reliably detecting the burst end in the *Burst Average* mode with modulated signals (e. g. with digital standards NADC, PDC, PHS, etc.). The dropout tolerance should be selected larger than the longest amplitude drop and smaller than the gap between two consecutive bursts. The default value is sufficient for all usual digital communication standards.

The query yields the dropout tolerance for the *Burst Average* mode.

Default setting: *0.0001 [s]*

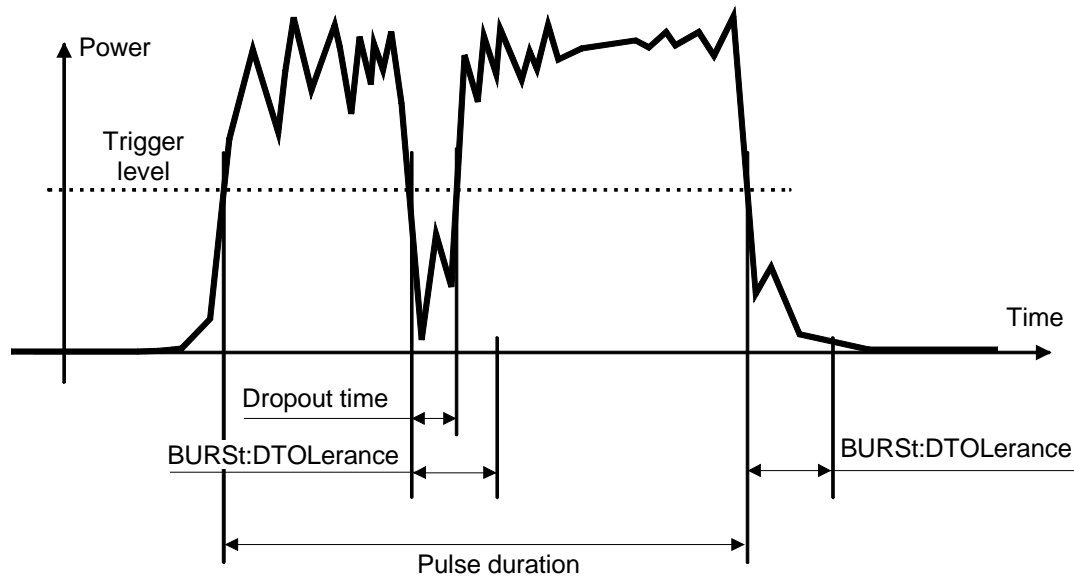

Fig. 6-1 Effect of `SENSe:POWer:BURSt:DTOLerance`

`SENSe:POWer:TSLot:AVG:COUNT[?]` 1 to 128

For the Timeslot mode, `SENSe:POWer:TSLot:AVG:COUNT` sets the number of consecutive timeslots that are to be processed after each trigger event.

The query yields the number of consecutive timeslots.

Default setting: 1

`SENSe:POWer:TSLot:AVG:WIDTH[?]` 0.0001 to 0.1

`SENSe:POWer:TSLot:AVG:WIDTH` sets the length of a timeslot in seconds for the Timeslot mode.

The query yields the length of a timeslot in seconds for the Timeslot mode.

Default setting: 0.001 [s]

`SENSe:RANGe[?]` 0 to 2

`SENSe:RANGe` selects the measurement path of the sensor. The sensor has three separate measurement paths. Path 1 is the most sensitive, path 2 medium and path 3 the least sensitive. `SENSe:RANGe 0` selects path 1, `SENSe:RANGe 1` path 2 and `SENSe:RANGe 2` path 3.

The dynamic ranges of these measurement paths depend on temperature and are model-specific. Reference values are 40 μ W (-14 dBm) for the most sensitive measurement path, 4 mW (6 dBm) for the medium one and 400 mW (26 dBm) for the least sensitive.

The query yields

- 0 for path 1,
- 1 for path 2,
- 2 for path 3.

If the measurement path is selected manually (`SENSe:RANGe:AUTO OFF`), the currently selected measurement path is output. With automatic selection, the last path that was set manually is output. It is therefore immediately reset after deactivating the automatic function.

Default setting: 2 (least sensitive path)

SENSe:RANGe:AUTO[?] OFF | ON

SENSe:RANGe:AUTO ON activates the automatic selection of the measurement path and *SENSe:RANGe:AUTO OFF* deactivates it.

The query yields

- 1 for *OFF*,
- 2 for *ON*.

Default setting: *ON*

SENSe:RANGe:AUTO:CLeVel[?] -20.0 to 0.0

SENSe:RANGe:AUTO:CLeVel is used to reduce the transition range between measurement paths 1 and 2 or 2 and 3 by the indicated value (in dB). This can improve the measurement accuracy for signals with a high *peak-to-average* ratio, since the headroom for modulation peaks becomes larger. The disadvantage is that the S/N ratio is reduced at the lower limits of the transition ranges.

The query yields the offset of transition ranges between measurement channels 1 and 2 or 2 and 3.

Default setting: *0.0 [dB]*

SENSe:SAMPling[?] FREQ1 | FREQ2

SENSe:SAMPling is used to vary the sampling frequency of the analog-digital converter in the sensor. With parameter specification *FREQ1* the sampling frequency is 133.400 kHz, and 119.467 kHz with parameter *FREQ2*. This is provided to suppress interfering low-frequency mixture products from signal components and the sampling frequency.

The query yields

- 1 for *FREQ1*,
- 2 for *FREQ2*.

Default setting: *FREQ1*

SENSe:SGAMma:CORRection:STATe[?] OFF | ON

SENSe:SGAMma:CORRection:STATe ON initiates the use of the complex reflection coefficient of the source defined with *SENSe:SGAMma:MAGNitude* and *SENSe:SGAMma:PHASe* for the correction of interactions between the sensor, the source and the components connected between them (see *SENSe:CORRection:SPDevice:STATe*). This compensates for the source mismatch, which often largely contributes to measurement uncertainty.

The query yields

- 1 for *OFF*,
- 2 for *ON*.

Default setting: *OFF*

SENSe:SGAMma:MAGNitude[?] 0.0 to 1.0

SENSe:SGAMma:MAGNitude defines the magnitude of the complex reflection coefficient of the source. A value of 0.0 corresponds to an ideal matched source and a value of 1.0 to total reflection.

The query yields the set magnitude.

Default setting: 0.0

SENSe:SGAMma:PHASe[?] -360.0 to 360.0

SENSe:SGAMma:PHASe defines the phase angle (in degrees) of the complex reflection coefficient of the source.

The query yields the set phase angle.

Default setting: 0.0 [°]

SENSe:TRACe:AVERage:COUNT[?] 1 to 65536

SENSe:TRACe:AVERage:COUNT is used to set the number of measured values to be averaged in the *Scope* mode for the formation of the measurement result. The higher this averaging factor, the lesser the fluctuation the measured values and the longer the measurement time. The parameter is rounded off to the next power-of-two number.

The query yields the averaging factor used in the *Scope* mode.



The averaging function must be activated with SENSe:TRACe:AVERage:STATe ON so that the set averaging factor becomes effective.

Default setting: 4

SENSe:TRACe:AVERage:COUNT:AUTO[?] OFF | ON | ONCE

SENSe:SWep:AVERage:COUNT:AUTO activates (auto-averaging) or deactivates (fixed-filter mode) the automatic determination of the averaging factor in the *Scope* mode. If auto-averaging is activated, the averaging factor is continuously determined and set depending on the level of power and other parameters.

SENSe:TRACe:AVERage:COUNT:AUTO ON activates auto-averaging and *SENSe:TRACe:AVERage:COUNT:AUTO OFF* deactivates it. When deactivation occurs, the previous, automatically determined averaging factor is used in the fixed-filter mode. The *SENSe:TRACe:AVERage:COUNT:AUTO ONCE* command ensures that a new averaging factor is determined by the filter automatic function under the current measurement conditions and that this factor is used in the fixed-filter mode.

The query yields

- 1 for OFF,
- 2 for ON.

Default setting: OFF

SENSe:TRACe:AVERAge:COUNT:AUTO:MTIME[?] 1.0 to 999.99

SENSe:TRACe:AVERAge:COUNT:AUTO:MTIME sets the settling time upper limit of the averaging filter in the auto-averaging mode for the *Scope* mode and limits the length of the filter.

The query yields the current settling time upper limit of the averaging filter in the auto-averaging mode for the *Scope* mode.

Default setting: 30.0 [s]

SENSe:TRACe:AVERAge:COUNT:AUTO:NSRatio[?] 0.0001 to 1.0

SENSe:TRACe:AVERAge:COUNT:AUTO:NSRatio determines the relative noise component in the measurement result for the *Scope* mode if auto-averaging is operated in the corresponding mode (*SENSe:TRACe:AVERAge:COUNT:AUTO:TYPE NSRatio*). The noise component is defined as the magnitude of the level variation in dB caused by the inherent noise of the sensor (two standard deviations).

The query yields the relative noise component in the measurement result in the *Scope* mode.

Default setting: 0.01 [dB]

SENSe:TRACe:AVERAge:COUNT:AUTO:RESolution[?] 1 to 4

SENSe:TRACe:AVERAge:COUNT:AUTO:RESolution sets the resolution index for the automatic averaging filter in the *Scope* mode when it is operated in the *RESolution* mode. The resolution index is equal to the number of decimal places that have to be taken into account for the further processing of the measurement result in dBm, dB μ V or dB. Thus, the design of the normal mode is similar to that for the predecessors R&S NRVS and R&S NRVD or other commercial power meters. The higher the selected index, the better the measurement result is filtered without the last significant place (0.01 dB with an index of 3) being actually set. The *NSRatio* setting is recommended instead.

The query yields the resolution index for the *Scope* mode.

Default setting: 3

SENSe:TRACe:AVERAge:COUNT:AUTO:POINT[?] 1 to <SENSe:TRACe:POINTS>

SENSe:TRACe:AVERAge:COUNT:AUTO:SLOT defines the "point" whose power is referenced by auto-averaging in the *Scope* mode. The "point" is addressed via its number, the counting beginning with 1. The "point" number must not exceed the number of the currently set "points". If a valid "point" number is initially set and then the number of "points" reduced to a value that is smaller than the initial "point" number, the initial value is automatically set to the new "point" number, i.e. auto-averaging references the most recent "point".

The query yields the number of the current "point" whose power is referenced by auto-averaging in the *Scope* mode.

Default setting: 1

SENSe:TRACe:AVERAge:COUNt:AUTO:TYPE[?] RESolution | NSRatio

SENSe:TRACe:AVERAge:COUNt:AUTO:TYPE defines the mode of the automatic averaging filter in the *Scope* mode. The *RESolution* parameter sets the mode usual for power meters; *NSRatio* predefines the compliance to an exactly defined noise component.

The query yields

- 1 for *RESolution*,
- 2 for *NSRatio*.

Default setting: *RESolution*

SENSe:TRACe:AVERAge:STATe[?] OFF | ON

SENSe:TRACe:AVERAge:STATe switches the averaging filter on or off for the *Scope* mode.

The query yields

- 1 for *OFF*,
- 2 for *ON*.

Default setting: *ON*

SENSe:TRACe:AVERAge:TCONtrol[?] MOVing | REPEAT

SENSe:TRACe:AVERAge:TCONtrol (*terminal control*) defines the behaviour of the averaging filter in the *Scope* mode. As soon as a new measured value is shifted to the FIR filter, a new mean is available at the filter output, which is obtained from the new measured value and the other values stored in the filter.

The *MOVing* parameter defines that each new average value is output as a measurement result. This allows trends in the result to be recognized during the measurement procedure.

The *REPEAT* parameter defines that a new result is output after the FIR filter has been filled with new measured values. This ensures that no redundant information is output.

The query yields

- 1 for *MOVing*,
- 2 for *REPEAT*.

Default setting: *MOVing*

SENSe:TRACe:MPWidth?

SENSe:TRACe:MPWidth? provides the *minimum point width* for the *Scope* mode, i.e. time resolution in seconds is determined as a function of the *TRIGger:SOURce* parameter while taking into consideration how the sensor operates. The display may be incorrect if

$$\langle \text{SENSe:TRACe:POINts} \rangle \times \langle \text{SENSe:TRACe:MPWidth} \rangle < \text{SENSe:TRACE:TIME} \rangle$$

One way to prevent this is to decrease the number of points of the *Scope* measurement sequence.

SENSe:TRACe:OFFSet:TIME[?] – (<TRIGger:DELay> + 0.005) to 100.0

This command is used to shift the timeslot for measured-data acquisition along the time axis in the *Scope* mode without modifying the value of *TRIGger:DELay*. Positive values yield an additional delay and negative values a correspondingly earlier measured-data acquisition.

The query yields the set time in seconds.

Default setting: 0.0 [s]

SENSe:TRACe:POINts[?] 1 to 1024

This command defines the time resolution of the measurement result. Each "point" represents a time interval whose duration is obtained from the length of the timeslot (command *SENSe:TRACe:TIME*) divided by the number of "points". The measurement result for a "point" equals the average power over the associated time interval.

The query yields the number of set "points".

Default setting: 100

SENSe:TRACe:REALtime[?] OFF | ON

SENSe:TRACe:REALtime ON suppresses the measured-value acquisition in pairs so that single operations can be recorded in this setting. Since the averaging filter of the sensor is not used, *SENSe:AVERAge:STATe* is ignored, but is not affected.

The query yields

- 1 for *OFF*,
- 2 for *ON*.

Default setting: *OFF*

SENSe:TRACe:TIME[?] 0.0001 to 0.3

SENSe:TRACe:TIME sets the duration of the timeslot in the *Scope* mode. This timeslot is divided into a number of equal intervals, in which the average power is determined. The number of intervals equals the number of test points, which is set with the command *SENSe:TRACe:POINts*.

The query yields the duration of the timeslot in the *Scope* mode (in s).

Default setting: 0.01 [s]

SENSe:TIMing:EXCLude:STARt[?] 0.0 to 0.1

SENSe:TIMing:EXCLude:STARt defines the exclusion time at the beginning of the measurement window in the *Burst Average* (Fig. 6-2) and *Timeslot* (Fig. 6-3) modes.

The query yields the exclusion time at the beginning of the measurement window.

Default setting: 0.0 [s]

SENSe:TIMing:EXCLude:STOP[?] 0.0 to 0.003

SENSe:TIMing:EXCLude:STOP defines the exclusion time at the end of the measurement window in the *Burst Average* (Fig. 6-2) and *Timeslot* (Fig. 6-3) modes.

The query yields the exclusion time at the end of the measurement window.

Default setting: 0.0 [s]

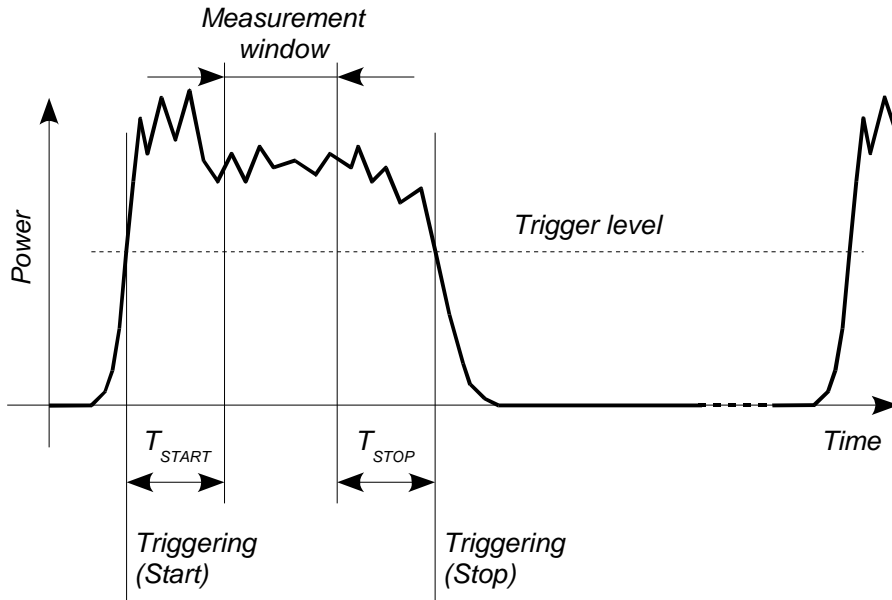

Fig. 6-2 Effect of *SENSe:TIMing:EXCLude:START* and *:END* in the *Burst Average* mode

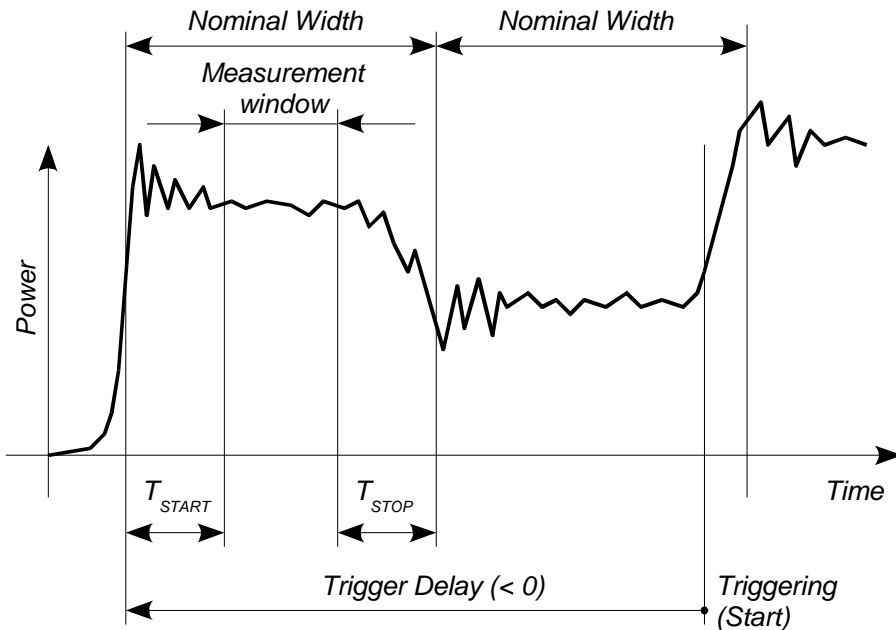

Fig. 6-3 Effect of *SENSe:TIMing:EXCLude:START* and *:END* in the *Timeslot* mode

SYSTEM

With the aid of the SYSTEM system, administrative device settings can be defined and queried. This includes detailed information on the sensor and its initialization and the transfer of available commands and their parameter limits.

Table 6-5 Commands of the SYSTEM system

Command	Parameter	Unit	Remarks
SYSTEM			
:INFO? [Item]			Query only
:INITialize			No query
MINPower?		W	Query only
:TRANsaction			
:BEGIN:			No query
:END			No query

SYSTEM:INFO? [Item]

SYSTEM:INFO? yields a string containing information that is more detailed than the identification string delivered by the sensor as a response to *IDN?. If no *Item* is specified, the response string is a sequence of entries in the form *Item:Information-String* separated by CR and LF (in C notation: \r\n). With the *Item* optionally appended to the command, the entry for the required *Item* can be queried. The response string is zero-terminated, i.e. its end identification is a zero byte (in C notation: \0).

Table 6-6 Meaning of *Item* in the SYSTEM:INFO? command

Item	Information string	Remarks
"MANUFACTURER"	"Rohde & Schwarz GmbH & Co. KG"	Manufacturer
"TYPE"	"NRP-Z11" or "NRP-Z21"	Type designation
"STOCK NUMBER"	"1138.3004.02" or "1137.6000.02"	Material number
"SERIAL"	"<serial number>"	6-digit serial number
"HWVERSION"	"000000000"	Hardware version (standard)
"HWVARIANT"	"000000000"	Hardware model (standard)
"SW BUILD"	"<build number>"	Version number of sensor firmware
"TECHNOLOGY"	"3 Path Diode"	Detector technology used
"FUNCTION"	"Power Terminating"	The R&S NRP-Z11/-Z21 is a termination power sensor.

Item	Information string	Remarks
"MINPOWER"	"<nominal lower test limit in W>"	The nominal lower test limit of the R&S NRP-Z11/-Z21 is 200 pW, i.e. with s-parameter correction deactivated, the sensor returns the information string "2e-10" as a response to "SYSTem:INFo? "MINPOWER". With s-parameter correction activated, the information string depends on the nominal lower limit of the sensor/twoport combination.
"MAXPOWER"	"<nominal upper test limit in W>"	The nominal upper test limit of the R&S NRP-Z11/-Z21 is 200 mW, i.e. with s-parameter correction deactivated, the sensor returns the information string "0.2" as a response to "SYSTem:INFo? "MAXPOWER". With s-parameter correction activated, the information string depends on the nominal upper limit of the sensor/twoport combination.
"MINFREQ"	"1e+07"	The minimum measuring frequency of the R&S NRP-Z11/-Z21 is 10 MHz.
"MAXFREQ"	"8e+09" or "1.8e+10"	The maximum measuring frequency is 8 GHz for the R&S NRP-Z11 and 18 GHz for the R&S NRP-Z21.
"RESOLUTION"	"2.5µs Ext, 10µs Int"	The maximum time resolution that can be reached in the Scope mode is 2.5 µs for internal triggering and 10 µs for external triggering.
"IMPEDANCE"	"50"	The R&S NRP-Z11/-Z21 RF input has a nominal input impedance of 50 Ω.
"COUPLING"	"AC/DC"	The RF input of the R&S NRP-Z11/-Z21 is DC-coupled, but DC voltages superimposed on the RF signal are suppressed by the measurement amplifier.
"CAL. ABS."	"<date>"	Date of absolute calibration in the format YYYY-MM-DD. "Invalid Calibration Date" is returned with an invalid date entry.
"CAL. REFL."	"<date>"	Date of reflection-coefficient calibration in the format YYYY-MM-DD. "Invalid Calibration Date" is returned with an invalid date entry.
"CAL. S PARA."	"<date>"	Date of s-parameter calibration in the format YYYY-MM-DD. If no S parameter set is loaded, the sensor returns the string "not applicable". "Invalid Calibration Date" is returned with an invalid date entry.
"CAL. MISC."	"<date>"	Date of the calibration of other parameters in the format YYYY-MM-DD. "Invalid Calibration Date" is returned with an invalid date entry.
"SPD MNEMONIC"	"<mnemonic string>"	Clear-text designation of the components connected ahead of the sensor.

SYSTem:INITialize

SYSTem:INITialize sets the sensor to the standard state, i.e. the default settings for all test parameters are loaded in the same way as with *RST. The sensor then outputs a complete list of all supported commands and parameters. With the command, the remote-control software can automatically adapt to the features of different types of sensors with different functionality.

SYSTEM:MINPower?

SYSTEM:MINPower? yields the lower test limit of the sensor or the combination comprising the sensor and components connected ahead of it, if the *SENSe:CORRection:SPDevice* parameter has the *ON* value. This query can be used to determine a useful resolution for the result display near the lower test limit.

SYSTEM:TRANsaction:BEgin

SYSTEM:TRANsaction:BEgin marks the beginning of a sequence of setting commands between which the parameter limits must not be checked. This prevents the display of error messages when a setting command causes a conflict that is resolved by a subsequent setting command. See *SYSTEM:TRANsaction:END*.

SYSTEM:TRANsaction:END

SYSTEM:TRANsaction:END marks the end of a sequence of setting commands between which the parameter limits must not be checked. After this command, the parameter limits are checked.

TEST

Table 6-7 Commands of the TEST system

Command	Parameter	Unit	Remarks
TEST:SENSor?			Query only

TEST:SENSor?

TEST:SENSor? triggers a selftest of the sensor. In contrast to *TST, this command yields detailed information, which is useful for troubleshooting.

TRIGger

Table 6-8 Commands of the TRIGger system

Command	Parameter	Unit	Remarks
ABORt			No query
INITiate			
:CONTInuous[?]	OFF ON		
:IMMEDIATE			No query
TRIGger			
:ATRigger:STATe[?]	OFF ON		
:COUNT[?]	1 to 2×10^9		
:DELay[?]	x to 100.0	s	
:AUTO[?]	OFF ON		
:HOLDoff[?]	0.0 to 10.0	s	
:HYSTERESIS[?]	0.0 to 3.0	dB	
:IMMEDIATE			No query
:LEVEL[?]	x to y	W	
:SLOPe[?]	POSitive NEGative		
:SOURce[?]	BUS EXTERNAL HOLD IMMEDIATE INTERNAL		

ABORt

ABORt interrupts the current measurement and sets the sensor to the *IDLE* state (normal case). However, if the sensor is in the continuous measurement mode (setting *INITiate:CONTInuous ON*), the *IDLE* state is immediately exited and the sensor enters the *WAIT_FOR_TRIGGER* state.

INITiate:CONTInuous[?] OFF | ON

INITiate:CONTInuous ON activates the continuous measurement mode. In this mode, a new measurement is automatically started when a measurement is terminated. The sensor first enters the *WAIT_FOR_TRIGGER* state and begins with the measurement as soon as the trigger condition is fulfilled. Once the measurement is completed, the sensor again enters the *WAIT_FOR_TRIGGER* state. The sensor will measure continuously assuming continuous trigger events.

In contrast, each measurement cycle must be explicitly started with the *INITiate:IMMEDIATE* command after the *INITiate:CONTInuous OFF* command has been sent. After triggering and completion of the measurement, the sensor enters the *IDLE* status and remains in this status until a new measurement is started with the *INITiate:IMMEDIATE* command.

The query yields

- 1 for OFF,
- 2 for ON.

Default setting: OFF

INITiate:IMMediate

INITiate:IMMediate starts a single measurement cycle. The sensor first changes from the *IDLE* state to the *WAIT_FOR_TRIGGER* state and begins with the measurement as soon as the trigger condition is fulfilled. Once the measurement is completed, the sensor again enters the *IDLE* state. Since the command is ignored during measurement, it normally has no effect in the continuous mode (setting *INITiate:CONTinuous ON*).

TRIGger:ATRigger:STATe[?] OFF | ON

TRIGger:ATRigger:STATe ON causes an artificial trigger event to be triggered if no trigger is recorded more than 10 s after the measurement has been started (only in the *Scope* mode). *TRIGger:ATRigger:STATe OFF* deactivates the trigger automatic function.

The query yields

- 1 for OFF,
- 2 for ON.

Default setting: OFF

TRIGger:COUNT[?] 1 to 2×10^9

This setting is designed for applications in which several consecutive measurements have to be performed by sending the *INITiate:IMMediate* command only once, e.g. to obtain a higher measurement speed. The gap between a single measurement and the continuous measurement mode is thus closed. The number of measurements is defined with the parameter associated with the *TRIGger:COUNT* command. This number equals the number of results yielded by the sensor at the end of the measurement.



The TRIGger:COUNT command does not define the number of trigger events required for performing the entire measurement task. The number may vary depending on the measurement mode.

*A further increase in the measurement speed can be obtained by combining the mode used with the buffered mode. The results are not made available immediately but as a block at the end of the measurement sequence (see group commands *SENSe:POWer:AVG:BUFFer*).*

The query yields the number of measurements performed with the *INIT:IMMediate* command after a measurement start.

Default setting: 1

TRIGger:DELAy[?] x to 100.0

TRIGger:DELAy defines the delay (in seconds) between the occurrence of the trigger event and the beginning of the measurement itself for the *Timeslot* and *Scope* modes. This parameter is ignored in the *Burst Average* mode. Pretriggering is obtained by means of negative values; with bus-triggered measurements (see *TRIGger:SOURce*), the parameter must be set to positive values or zero to avoid measurement errors.

The query yields the set trigger delay for the *Timeslot* and *Scope* modes (in seconds).

Lower limit x of the parameter

Modes *Continuous Average*, *Burst Average* and *Timeslot*: $x = -0.005$

Mode *Scope*: $x = - (<SENSe:TRACe:OFFSet:TIME> + 0.005)$

Default setting: *0.0 [s]*

TRIGger:DELAy:AUTO[?] OFF | ON

TRIGger:DELAy:AUTO ON ensures by means of an automatically determined delay that a measurement is only started after the sensor has settled. This is important when thermal sensors are used. The automatically determined delay is ignored if a longer period was set with *TRIGger:DELAy*. This does not overwrite the value of *TRIGger:DELAy*. *TRIGger:DELAy:AUTO OFF* deactivates this function.

The query yields

- 1 for *OFF*,
- 2 for *ON*.

Default setting: *ON*

TRIGger:HOLDoff[?] 0.0 to 10.0

TRIGger:HOLDoff suppresses trigger events within the set holdoff time (in s), starting from the time of the last successful triggering.

The query yields the set holdoff time (in s).

Default setting: *0.0 [s]*

TRIGger:HYSTeresis[?] 0.0 to 10.0

TRIGger:HYSTeresis sets the hysteresis of the internal trigger threshold (parameter *TRIGger:LEVe*). Hysteresis is the magnitude (in dB) by which the trigger signal level falls below the trigger threshold (with positive trigger edge) to enable triggering again. The case is exactly the opposite with a negative trigger edge. The trigger hysteresis setting is only relevant to the *INTernal* trigger source.

The query yields the trigger hysteresis in dB.

Default setting: *0.0 [dB]*

TRIGger:IMMediate

TRIGger:IMMediate triggers a generic trigger event that causes the sensor to exit immediately the *WAIT_FOR_TRIGGER* state irrespective of the trigger source and the trigger delay and begin with the measurement. The command is the only means of starting a measurement when the trigger source is set to *HOLD*.

TRIGger:LEVel[?] x to y

TRIGger:LEVel sets the trigger threshold for internal triggering derived from the test signal (in W). This setting is irrelevant to all other trigger sources.

The query yields the trigger threshold in W.

Lower limit x and upper limit y of parameter

SENSe:CORRection:OFFSet:STATe OFF: $x = 500 \times \langle \text{lower test limit} \rangle$
 $y = \langle \text{upper test limit} \rangle$

SENSe:CORRection:OFFSet:STATe ON: $x = 500 \times \langle \text{lower test limit} \rangle \times$
 $10^{(\langle \text{SENSe:CORRection:OFFSet} \rangle / 10)}$
 $y = \langle \text{upper test limit} \rangle \times$
 $10^{(\langle \text{SENSe:CORRection:OFFSet} \rangle / 10)}$

$\langle \text{lower test limit} \rangle$: 200.0e-12 (with *SENSe:CORRection:SPDevice:STATe OFF*) or entered lower test limit of sensor/twoport combination (with *SENSe:CORRection:SPDevice:STATe ON*)

$\langle \text{upper test limit} \rangle$: 0.2 (with *SENSe:CORRection:SPDevice:STATe OFF*) or entered upper test limit of sensor/twoport combination (with *SENSe:CORRection:SPDevice:STATe ON*)

Default setting: $10 \times x$

TRIGger:SLOPe[?] POSitive | NEGative

TRIGger:SLOPe defines the edge of the trigger event with internal and external triggering in the *Timeslot* and *Scope* modes. In this connection, positive means increasing envelope power (with internal triggering) or increasing voltage (with external triggering). As in the *Burst Average* mode, this command has no effect in conjunction with trigger sources *BUS*, *HOLD* and *IMMEDIATE*.

The query yields

- 1 for *POSitive*,
- 2 for *NEGative*.

Default setting: *POSitive*

TRIGger:SOURce[?] BUS | EXTernal | HOLD | IMMEDIATE | INTernal

TRIGger:SOURce sets the trigger source.

- *BUS*: Triggering with command **TRG* or *TRIGger:IMMEDIATE*.
- *EXTernal*: Triggering via USB Adapter R&S NRP-Z3. Relevant trigger parameters: *TRIGger:DELay* and *TRIGger:SLOPe*.
- *HOLD*: Triggering only with command *TRIGger:IMMEDIATE*.
- *IMMEDIATE*: Automatic triggering without explicit event.
- *INTernal*: Triggering by the measurement signal. Relevant trigger parameters: *TRIGger:LEVel*, *TRIGger:DELay* and *TRIGger:SLOPe* (not in the *Burst Average* mode).

The query yields

- 1 for *BUS*,
- 2 for *EXTernal*,
- 4 for *HOLD*,
- 8 for *IMMEDIATE*,
- 16 for *INTernal*.

Default setting: *IMMEDIATE*

List of Remote-Control Commands

The remote-control commands of the R&S NRP-Z11/-Z21 have a syntax based on standard SCPI 1999.0, but they comply with it only to a limited extent.

Table 6-9 List of remote-control commands

Command	Parameter	Unit	Default setting	Page
* Commands				
*IDN?				6.2
*RST				6.2
*TRG				6.2
*TST?				6.2
CALibration Commands				
CALibration:DATA[?]	<calibration data set as definite length block>			6.3
CALibration:DATA:LENGth?		Bytes		6.3
CALibration:ZERO:AUTO[?]	OFF ON ONCE		OFF (fixed)	6.4
SENSe Commands				
SENSe:AVERage:COUNT[?]	1 to 65536		4	6.7
SENSe:AVERage:COUNT:AUTO[?]	OFF ON ONCE		ON	6.7
SENSe:AVERage:COUNT:AUTO:MTIME[?]	1.0 to 999.99	s	30.0	6.8
SENSe:AVERage:COUNT:AUTO:NSRatiO[?]	0.0001 to 1.0	dB	0.01	6.8
SENSe:AVERage:COUNT:AUTO:RESolution[?]	1 to 4		3	6.8
SENSe:AVERage:COUNT:AUTO:SLOT[?]	1 to <SENSe:POWer:TSLot:AVG:COUNT>		1	6.8
SENSe:AVERage:COUNT:AUTO:TYPE[?]	RESolution NSRatiO		RESolution	6.9
SENSe:AVERage:RESet				6.9
SENSe:AVERage:STATe[?]	OFF ON		ON	6.9
SENSe:AVERage:TCONtrol[?]	MOVing REPeat		REPeat	6.9
SENSe:CORRection:DCYClE[?]	0.001 to 99.999	%	1.0	6.10
SENSe:CORRection:DCYClE:STATe[?]	OFF ON		OFF	6.10
SENSe:CORRection:OFFSet[?]	-200.0 to 200.0	dB	0.0	6.10

Command	Parameter	Unit	Default setting	Page
SENSe:CORRection:OFFSet:STATe[?]	OFF ON		OFF	6.10
SENSe:CORRection:SPDev:STATe[?]	OFF ON		OFF (can be modified by the user)	6.11
SENSe:FREQuency[?]	10.0e6 to 8.0e9 (NRP-Z11) or 18.0e9 (NRP-Z21)	Hz	50.0e6	6.11
SENSe:FUNcTION[?]	"POWer:AVG" "POWer:TSLot:AVG" "POWer:BURSt:AVG" "XTIME:POWer"		"POWer:AVG"	6.12
SENSe:POWer:AVG:APERture[?]	0.0001 to 0.3	s	0.02	6.13
SENSe:POWer:AVG:BUFFer:SIZE[?]	1 to 1024		1	6.13
SENSe:POWer:AVG:BUFFer:STATe[?]	OFF ON		OFF	6.14
SENSe:POWer:AVG:SMOothing:STATe[?]	OFF ON		ON	6.14
SENSe:POWer:BURSt:DTOLerance[?]	0.0 to 0.003	s	0.0001	6.14
SENSe:POWer:TSLot:AVG:COUNt[?]	1 to 128		8	6.15
SENSe:POWer:TSLot:AVG:WIDTh[?]	0.0001 to 0.1	s	0.001	6.15
SENSe:RANGe[?]	0 to 2		2	6.15
SENSe:RANGe:AUTO[?]	OFF ON		ON	6.16
SENSe:RANGe:AUTO:CLeVel[?]	-20.0 to 0.0	dB	0.0	6.16
SENSe:SAMPLING[?]	FREQ1 FREQ2		FREQ1	6.16
SENSe:SGAMma:CORRection:STATe[?]	OFF ON		OFF	6.16
SENSe:SGAMma:MAGNitude[?]	0.0 to 1.0		0.0	6.17
SENSe:SGAMma:PHASe[?]	-360.0 to 360.0	degree	0.0	6.17
SENSe:TRACe:AVERAge:COUNt[?]	1 to 65536		4	6.17
SENSe:TRACe:AVERAge:COUNt:AUTO[?]	OFF ON ONCE		ON	6.17
SENSe:TRACe:AVERAge:COUNt:AUTO:MTIME[?]	1.0 to 999.99	s	30.0	6.18
SENSe:TRACe:AVERAge:COUNt:AUTO:NSRatio[?]	0.0001 to 1.0	dB	0.01	6.18
SENSe:TRACe:AVERAge:COUNt:AUTO:POINt[?]	1 to <SENSe:TRACe:POINts>		1	6.18
SENSe:TRACe:AVERAge:COUNt:AUTO:RESolution[?]	1 to 4		3	6.18
SENSe:TRACe:AVERAge:COUNt:AUTO:TYPE[?]	RESolution NSRatio		RESolution	6.19

Command	Parameter	Unit	Default setting	Page
SENSe:TRACe:AVERAge:STATe[?]	OFF ON		ON	6.19
SENSe:TRACe:AVERAge:TCONtrol[?]	MOVing REPeat		REPeat	6.19
SENSe:TRACe:MPWidth?		s		6.19
SENSe:TRACe:OFFSet:TIME[?]	– (<TRIGger:DELay> + 0.005) to 100.0	s	0.0	6.19
SENSe:TRACe:POINts[?]	1 to 1024		100	6.20
SENSe:TRACe:REALtime[?]	OFF ON		OFF	6.20
SENSe:TRACe:TIME[?]	0.0001 to 0.3	s	0.01	6.20
SENSe:TIMing:EXCLude:STARt[?]	0.0 to 0.003	s	0.0	6.20
SENSe:TIMing:EXCLude:STOP[?]	0.0 to 0.003	s	0.0	6.20
SYSTEM Commands				
SYSTem:INFO? [Item]				6.22
SYSTem:INITialize				6.23
SYSTem:MINPower?		W		6.24
SYSTem:TRANsaction:BEgIn				6.23
SYSTem:TRANsaction:END				6.24
Test Commands				
TEST:SENSor?				6.25
Triggersystem Commands				
ABORt				6.26
INITiate:CONTinuous[?]	OFF ON		OFF	6.26
INITiate:IMMediate				6.27
TRIGger:ATRigger:STATe[?]	OFF ON		OFF	6.27
TRIGger:COUNt[?]	1 to 2×10 ⁹		1	6.27
TRIGger:DELay[?]	x to 100.0	s	0.0	6.28
TRIGger:DELay:AUTO[?]	OFF ON		OFF	6.28
TRIGger:HOLDoff[?]	0.0 to 10.0	s	0.0	6.28
TRIGger:HYSTeresis[?]	0.0 to 10.0	dB	0.0	6.28

Command	Parameter	Unit	Default setting	Page
TRIGger:IMMEDIATE				6.28
TRIGger:LEVel[?]	x to y	W	1.0e-6	6.29
TRIGger:SLOPe[?]	POSitive NEGative		POSitive	6.29
TRIGger:SOURce[?]	BUS EXTernal HOLD IMMEDIATE INTernal		IMMEDIATE	6.29
SERVICE Commands				
SERvice:CALibration:DITHer	ONCE		OFF	
SERvice:CALibration:DITHer:DATA?			0	
SERvice:CALibration:TEMP	ONCE		OFF	
SERvice:CALibration:TEMP:DATA?		K	0.0	
SERvice:CALibration:TEST[?]			-1	
SERvice:CALibration:ZERO:NEG0?			1	
SERvice:CALibration:ZERO:POS0?			2	
SERvice:CALibration:ZERO:NEG1?			3	
SERvice:CALibration:ZERO:POS1?			4	
SERvice:CALibration:ZERO:NEG2?			5	
SERvice:CALibration:ZERO:POS2?			6	
SERvice:DITHer	OFF ON		ON	
SERvice:MVCorrection[?]	0 to 63		63	
SERvice:PARAmeter:RTEmp[?]	<float value>	K	0.0	
SERvice:PARAmeter:RNULL0[?]	<float value>	Ω	0.0	
SERvice:PARAmeter:RNULL1[?]	<float value>	Ω	0.0	
SERvice:PARAmeter:RNULL2[?]	<float value>	Ω	0.0	
SERvice:PARAmeter:RBAHN[?]	<float value>	Ω	0.0	
SERvice:PARAmeter:NREF[?]	<float value>		0.0	
SERvice:PARAmeter:ATHERM[?]	<float value>	K^{-1}	0.0	
SERvice:PARAmeter:BATHERM[?]	<float value>	K	0.0	
SERvice:PARAmeter:CTHERM[?]	<float value>	K^{-1}	0.0	
SERvice:PARAmeter:DATHERM[?]	<float value>	K^{-1}	0.0	

Command	Parameter	Unit	Default setting	Page
SERVice:PARAmeter:CJUNC[?]	<float value>	F	0.0	
SERVice:RCount[?]	1 to 32767		0	
SERVice:RESult[?]	0.0 to 1.0e6	W	0.0	
SERVice:SAMPlE[?]	0 to 99999999		1000	
SERVice:TDEScriptor?				
SERVice:TDEScriptor:LENGth?		Bytes		
SERVice:UNLock	1234			



ROHDE & SCHWARZ

Test and Measurement
Division

Service Instructions

Contents

1	Performance Test	1.1
	Preliminary Remarks	1.1
	Test Instructions	1.1
	Measuring Equipment and Accessories	1.1
	Performance Test	1.2
	with Calibration Kit NRVC and Calibration Software <i>Recal</i>	1.2
	Performance Test with Other Measuring Equipment	1.2
	Checking Absolute Measuring Accuracy	1.2
	Checking the Linearity.....	1.3
	Checking Matching.....	1.4
	Quick Test	1.5
	Test Instructions	1.5
	Measuring Equipment and Accessories Required for the Quick Test	1.6
	Checking Zeroing	1.6
	Checking the Absolute Measuring Accuracy	1.7
	Checking the Linearity.....	1.7
	Checking Input Resistance	1.8
	Test Report	1.9
2	Adjustment	2.1
	Preliminary Remarks	2.1
3	Repair of Sensors R&S NRP-Z11/-Z21	3.1
	Design and Circuit Description	3.1
	Block Diagram	3.1
	Description of Block Diagram.....	3.2
	Microwave Detector.....	3.2
	Analog Board.....	3.3
	Digital Board.....	3.3

Module Replacement	3.4
Tools Required	3.4
List of Modules	3.6
Opening and Reassembly (Exchange of Plastic Shell Halves)	3.7
Replacement of Sensor Cable W1	3.9
Removing the Sensor Cable	3.9
Installing the Sensor Cable	3.9
Troubleshooting	3.10
Overview of Errors, Causes and Corrective Steps	3.11
4 Firmware Update/Installation of Options	4.1
Installation of New R&S NRP-Z11/-Z21 Software	4.1
Hardware and software requirements.....	4.1
Preparation.....	4.2
Updating the application firmware.....	4.3
Updating the boot loader.....	4.4
5 Documents	5.1
Shipping of Instrument and Ordering of Spare Parts	5.1
Shipping of Instrument	5.1
Ordering Spare Parts	5.1
Ordering Replacement Sensors.....	5.2
Spare Parts	5.3

Figures

Fig. 1-1	Connection of DUT for measuring the input resistance	1.8
Fig. 3-1	Block diagram of Sensors R&S NRP-Z11 and R&S NRP-Z21	3.1
Fig. 3-2	Membrane cables	3.5
Fig. 3-3	Opening the sensor	3.7
Fig. 3-4	Replacement of sensor cable	3.9

Tables

Table 1-1	Calibration powers	1.2
Table 1-2	Expanded calibration uncertainties of Sensors R&S NRP-Z11/-Z21 (in dB)	1.2
Table 1-3	Max. measurement error (in dB) between meas. paths 1 and 2 at -20 dBm (10 μ W)	1.3
Table 1-4	Expanded linearity uncertainties of Sensors R&S NRP-Z11 and R&S NRP-Z21 at 50 MHz (in dB, with reference to 0 dBm)	1.3
Table 1-5	Max. SWR of Sensors R&S NRP-Z11 and R&S NRP-Z21	1.4
Table 2-1	Uncertainty of power calibration system at 0 dBm (in dB, including mismatch)	2.1
Table 3-1	Assignment of flexstrip connector W3	3.2
Table 3-2	List of modules/spare parts for R&S NRP-Z11 and R&S NRP-Z21	3.6

1 Performance Test

Preliminary Remarks

Verifying the data sheet specifications for the Power Sensors R&S NRP-Z11 and R&S NRP-Z21 requires a considerable amount of equipment and care. Rohde & Schwarz therefore recommends using the Power Calibration System R&S NRVC or corresponding equipment that yields the same accuracy. The tests are to be carried out directly at the manufacturer, its representatives or subsidiaries or at calibration sites that are equipped accordingly.

A **quick test** (see page 1.5) is recommended for checking the sensor with simple means.

Test Instructions

- The tests are to be performed at an ambient temperature of 20°C to 25°C. The DUT should be connected to the (activated) R&S NRP base unit for at least 30 minutes before the tests are performed.
- The test limits used in the following sections are based on the data sheet for the sensors R&S NRP-Z11 and R&S NRP-Z21. The test limits are valid only on the conditions defined in the corresponding test step. They are therefore not legally binding as accuracy specifications; only data sheet specifications are legally binding.

Measuring Equipment and Accessories

Item	Type of unit	Recommended characteristics	Recommended units	R&S order number	Application
1	Power calibration system	10 MHz to 18 GHz Calibration level 0 dBm	R&S NRVC R&S NRVC-B1 R&S SMP02 R&S NRVD	1109.0500.02 1109.1007.02 1035.5005.02 0857.8008.02	Absolute measuring accuracy
2	Linearity calibration system	-30 dBm to +23 dBm Test frequency 50 MHz	R&S NRVC-B2 R&S SMGL	1109.1207.02 1020.2005.52	Linearity
3	Network analyzer	10 MHz to 18 GHz Test port: N connector	R&S ZVM	1127.8500.60	Matching
4	Controller ¹	PC with IEC/IEEE-bus card (NI)			In connection with R&S NRVC and R&S NRVC-B2
5	Power meter	To connect the DUT	R&S NRP	1143.8500.02	Absolute measuring accuracy

¹ For program-controlled calibration in connection with Calibration Kit R&S NRVC and Calibration Software *Recal*.

Performance Test with Calibration Kit NRVC and Calibration Software *Recal*

For detailed information about the performance test, refer to the operating manual for Calibration Kit R&S NRVC.

SWR measurement has to be carried out on a separate network analyzer. Evaluation is performed by Calibration Software *Recal*.

Performance Test with Other Measuring Equipment

Checking Absolute Measuring Accuracy

The sensor contains three measurement paths. Individual calibration factors are stored for these measurement paths in the sensor. The measurement paths therefore have to be checked separately. (Table 1-1 and Table 1-2). The maximum permissible error depends on the calibration uncertainties of the sensor (Table 1-2) and the uncertainties of the calibration system. It is recommended to combine both uncertainties according to the RSS method (square root based on the sum of squares) and to use the expanded combined uncertainty as the test limit.

To calibrate measurement path 1, the measurement result of measurement path 2 can be used if the calibration system does not provide a calibration power of 10 μ W or if its uncertainty is too high. In this case, only the displayed difference between the two measurement paths will be checked (Table 1-3).

Table 1-1 Calibration powers

Measurement path	Power measurement range		Calibration power
1	200 pW to 50 μ W	(-67 dBm to -13 dBm)	10 μ W
2	20 nW to 5 mW	(-47 dBm to +7 dBm)	1 mW
3	2 μ W to 200 mW	(-27 dBm to +23 dBm)	1 mW

Table 1-2 Expanded calibration uncertainties of Sensors R&S NRP-Z11/-Z21 (in dB)

Frequency	10 MHz to <20 MHz	20 MHz to <100 MHz	100 MHz to 4 GHz	>4 GHz to 8 GHz	>8 GHz to 12.4 GHz	>12.4 GHz to 18 GHz
Measurement path	Only R&S NRP-Z21					
1	0.056	0.056	0.066	0.083	0.094	0.123
2	0.047	0.047	0.057	0.071	0.076	0.099
3	0.048	0.047	0.057	0.072	0.076	0.099

Calibration frequencies: 10 MHz, 15 MHz, 20 MHz, 30 MHz, 50 MHz, 100 MHz;
from 250 MHz to 18 GHz in 250 MHz steps.

Table 1-3 Max. measurement error (in dB) between meas. paths 1 and 2 at –20 dBm (10 μW)

Frequency	10 MHz to <20 MHz	20 MHz to <100 MHz	100 MHz to 4 GHz	>4 GHz to 8 GHz	>8 GHz to 12.4 GHz	>12.4 GHz to 18 GHz
					Only R&S NRP-Z21	
Measurement error	0.045	0.044	0.048	0.054	0.063	0.079

Procedure:

- Perform zeroing (without power applied).
- Set measurement path in **Sensor – Range** menu on the R&S NRP.
- Set calibration frequency in **Frequency** menu on the R&S NRP.
- Read power on the R&S NRP and compare with power value of calibration system. At least three measurements are recommended, with the sensor set to a different position with respect to the output connector of the calibration system each time.

Checking the Linearity

The linearity check is performed at 50 MHz with autoranging activated. The reference power is 1 mW (0 dBm). The maximum permissible linearity error depends on the linearity uncertainty of the sensor (Table 1-4) and the linearity uncertainty of the calibration system. It is recommended to combine both uncertainties according to the RSS method (square root based on the sum of squares) and to use the expanded combined uncertainty as the test limit.

Table 1-4 Expanded linearity uncertainties of Sensors R&S NRP-Z11 and R&S NRP-Z21 at 50 MHz (in dB, with reference to 0 dBm)

Test level	-30 dBm to -13 dBm	-13 dBm to +1 dBm	+1 dBm to +23 dBm
Uncertainty	0.044	0.022	0.044

Calibration levels: -30 dBm, -25 dBm, -20 dBm, -15 dBm, -10 dBm, -5 dBm, 0 dBm, +5 dBm, +10 dBm, +15 dBm, +20 dBm, +23 dBm

Procedure:

- Perform zeroing (without power applied).
- Set autoranging in **Sensor – Range** menu on the R&S NRP.
- Set 50 MHz in **Frequency** menu on the R&S NRP.
- Apply level of 0 dBm and activate **Relative On** in the **Measurement** menu on the R&S NRP. Use the current measurement value as the reference value (**Reset**). Set unit to **dB**.
- Set the calibration level and compare the relative level measured by the R&S NRP with that of the calibration system.

Checking Matching

For these measurements, the sensor can be operated with or without the R&S NRP base unit. The measurement procedure depends on the network analyzer used.

Table 1-5 Max. SWR of Sensors R&S NRP-Z11 and R&S NRP-Z21

Frequency	10 MHz to <30 MHz	30 MHz to 2.4 GHz	>2.4 GHz to 8 GHz	>8 GHz to 12.4 GHz	>12.4 GHz to 18 GHz
				Only R&S NRP-Z21	
Max. SWR	1.13	1.11	1.18	1.23	1.23

Quick Test

The following tests are used to check the R&S NRP-Z11 and R&S NRP-Z21 with simple means. If the tests are passed, compliance of the sensors with the specifications within the complete frequency and power range is largely ensured.

The test consists of:

- Zeroing.
- Absolute measuring accuracy at 0 dBm (50 MHz).
- Linearity when changing the measurement path (50 MHz).
- Input resistance (for DC voltage/current).

Test Instructions

- The tests are to be performed at an ambient temperature of 15°C to 35°C. The DUT should be connected to the (activated) R&S NRP base unit for at least 30 minutes before the tests are performed.
- The test limits used in the following sections are based on the data sheet but are valid only on the conditions defined for the corresponding test step. They are therefore not binding as far as accuracy is concerned but are strictly data sheet information.
- The entries made on the Power Meter R&S NRP are abbreviated as follows:
 - [<KEY>] Press front-panel key, e.g. [**FREQ**].
 - [<SOFTKEY>] Press softkey, e.g. [Range].
 - [<nn unit>] Enter value and confirm with unit, e.g. [**3 GHz**].Successive entries are separated by [:], e.g. [**FREQ : 3 GHz**].

Measuring Equipment and Accessories Required for the Quick Test

Item	Type of unit	Recommended characteristics	Recommended units	R&S order number	Application
1	Power meter	For connecting the DUT with power reference 1 mW / 50 MHz Expanded uncertainty <1.2 %	R&S NRP R&S NRP-B1	1143.8500.02 1146.9008.02	Absolute measuring accuracy Linearity
2	Signal generator	50 MHz Output level -20 dBm ... 0 dBm	R&S SML01	1090.3000.11	Linearity
3	System voltmeter	4-wire resistance measurement at 50 Ω Expanded measurement uncertainty <0.2 Ω			Input resistance
4	Adapter	BNC (plug) to 4-mm sockets (2-pin).		0017.6742.00	Input resistance
5	Adapter	BNC (socket) to N (socket).			Input resistance

Checking Zeroing

Test setup

- Sensor (DUT) is connected to power reference output of power meter (1).
- Power reference is switched off.

Settings on R&S NRP

- [**(PRE)SET: (PRE)SET**]
- [**ZERO/CAL: ZERO/CAL**]

Test

- Message "Zeroing A(B) successful".
- Display value is within limits of test report.

Checking the Absolute Measuring Accuracy

Test setup	- Sensor (DUT) is connected to power reference output. - Power reference is switched off.
Setting on R&S NRP	- [(PRE)SET: (PRE)SET: System: Power Ref On]
Test	- Display value is within the limits of test report.

Checking the Linearity

Test setup	- Sensor is connected to signal generator output
Setting on signal generator	- Frequency 50 MHz, output level -20 dBm, unmodulated.
Setting on R&S NRP	- [(PRE)SET: (PRE)SET: Sensor: Range: Auto <input type="checkbox"/> : Path 1]
Measurement	- On R&S NRP, approx. -20 dBm must be displayed.
Setting on R&S NRP	- [Measurement: Relative On: Reset]
Measurement	- On R&S NRP, 0.00 dB must be displayed.
Setting on R&S NRP	- [Sensor: Range: Auto <input type="checkbox"/> : Path 2]
Test	- Displayed value is within limits of Performance Test Report.
Setting on signal generator	- Frequency 50 MHz, output level 0 dBm, unmodulated.
Setting on R&S NRP	- [Sensor: Range: Auto <input type="checkbox"/> : Path 2]
Measurement	- On R&S NRP, approx. 0 dBm must be displayed.
Setting on R&S NRP	- [Measurement: Relative On: Reset]
Measurement	- On R&S NRP, 0.00 dB must be displayed.
Setting on R&S NRP	- [Sensor: Range: Auto <input type="checkbox"/> : Path 3]
Test	- Displayed value is within limits of Performance Test Report.

Checking Input Resistance

Test setup

- System voltmeter is set to 4-wire impedance measurement and is connected to DUT according to figure.

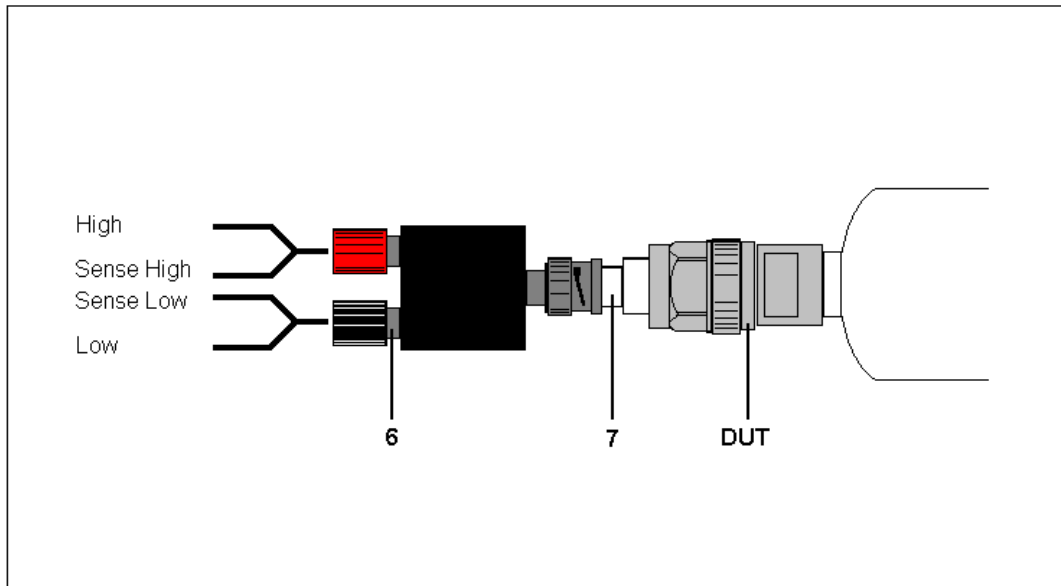

Fig. 1-1 Connection of DUT for measuring the input resistance

Test

- Check input resistance of sensor for compliance with limits of test report.

Test Report

Quick test					
Power Sensor R&S NRP-Z11					
Stock number: 1138.3004.02			Name:		
Serial number:			Date:		
Item no.	Characteristic	Min. value	Actual value	Max. value	Unit
1	Zeroing	-----		-67.0	dBm
2	Absolute measuring accur. at 0 dBm / 50 MHz	-0.10		+0.10	dBm
3	Linear. of meas. path 1 → 2	-0.10		+0.10	dB
4	Linear. of meas. path 2 → 3	-0.10		+0.10	dB
5	Input resistance	50.2		51.8	Ω

Quick test					
Power Sensor R&S NRP-Z21					
Stock number: 1137.6000.02			Name:		
Serial number:			Date:		
Item no.	Characteristic	Min. value	Actual value	Max. value	Unit
6	Zeroing	-----		-67.0	dBm
7	Absolute measuring accur. at 0 dBm / 50 MHz	-0.10		+0.10	dBm
8	Linear. of meas. path 1 → 2	-0.10		+0.10	dB
9	Linear. of meas. path 2 → 3	-0.10		+0.10	dB
10	Input resistance	50.2		51.8	Ω

2 Adjustment

Preliminary Remarks

The Sensors R&S NRP-Z11 and R&S NRP-Z21 cannot be adjusted manually but have to be adjusted by updating the calibration data in the memory. Calibration Software **Recal**, which is part of the equipment supplied with the Calibration Kit R&S NRVC, is therefore required. The measurement results for the absolute calibration of the three measurement paths which can be obtained during a performance test (see Section 1) form the basis of the adjustment. The Calibration Kit R&S NRVC is recommended but is not mandatory.

To ensure that the measuring accuracy corresponds to the data sheet values after the adjustment, the calibration system must not have any inaccuracies that are higher than those given in the table below.

Table 2-1 Uncertainty of power calibration system at 0 dBm (in dB, including mismatch)

Frequency	10 MHz to <20 MHz	20 MHz to <100 MHz	100 MHz to 4 GHz	>4 GHz to 8 GHz	>8 GHz to 12.4 GHz	>12.4 GHz to 18 GHz
					Only R&S NRP-Z21	
	0.04	0.04	0.05	0.065	0.07	0.09

For further details, refer to the operating manual for the Calibration Kit R&S NRVC or the online help for the **Recal** program.

3 Repair of Sensors R&S NRP-Z11/-Z21

This section describes the design and simple measures for repairing and determining faults as well as the replacement of modules.

The firmware update is explained in section 4 of this service manual.

Design and Circuit Description

Block Diagram

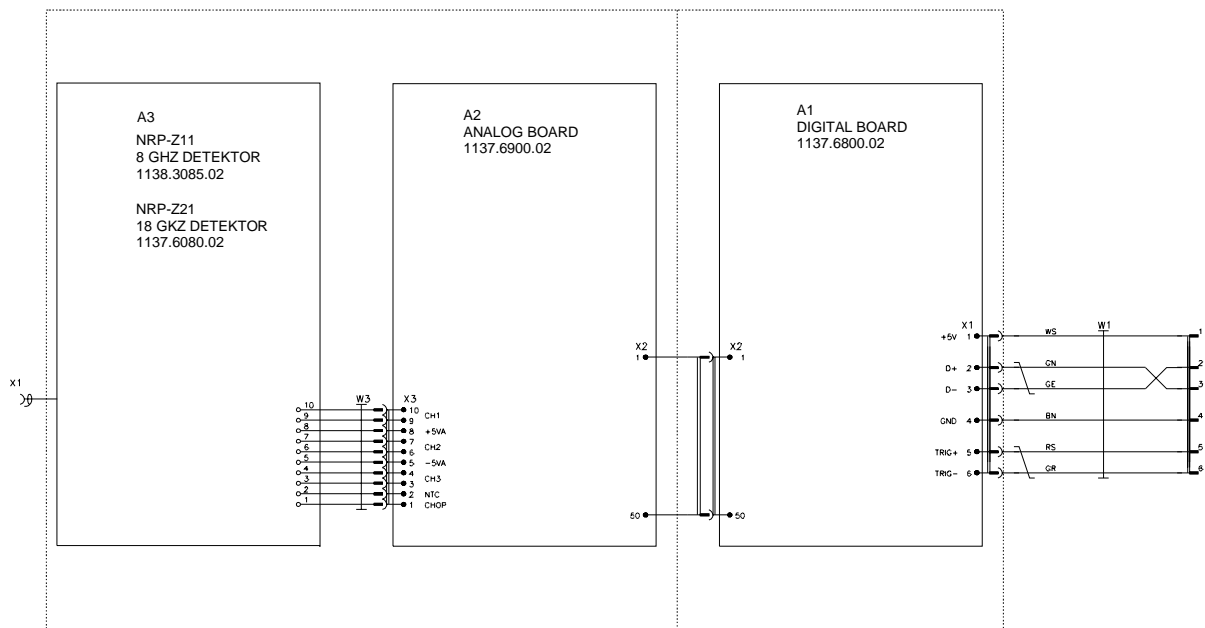

Fig. 3-1 Block diagram of Sensors R&S NRP-Z11 and R&S NRP-Z21

Description of Block Diagram

The Sensors R&S NRP-Z11 and R&S NRP-Z21 can determine the average power of almost any modulated RF signal over a large dynamic range. They include all modules required for analog and digital signal processing and provide fully corrected measured values. Communication with the R&S NRP base unit is handled via a USB interface.

Three detectors are used to obtain the large dynamic range of 90 dB (–67 dBm to +23 dBm); the input signal is fed unattenuated to path 1, attenuated by 20 dB to path 2 and attenuated by 40 dB to path 3. Sensitivity is highest on path 1, medium on path 2 and lowest on path 3.

Depending on the RF input signal level, one or two test paths are driven at such a level that these paths can be evaluated. A channel is always either driven at a very low level or overdriven. The output voltages of the three detectors are amplified and digitized independently of each other to obtain a continuous transition between the test paths. The digital values provided by the A/D converters undergo various corrections (zero offset, temperature, linearity). A weighting algorithm then decides which path or – in transition ranges – which two paths are to be evaluated, and forms a weighted measured value. Integration values that represent the average power of the RF signal in a predefined integration period are derived by averaging all sampling values within the integration period.

The final measured values are the averaged result from several integration values.

Microwave Detector

The microwave detector A3 is a hybrid circuit. It contains the three test paths and a thermistor for temperature measurement. The detector has an RF signal input and a flexstrip connector for output signals, control signals and operating voltages with the following assignment:

Table 3-1 Assignment of flexstrip connector W3

Connector	Signal name	Description
W3:1	CHOP	Logic signal for controlling the choppers
W3:2	NTC	Thermistor connector (the other connector of the thermistor is connected to ground)
W3:3 W3:4	CH3	Output of the most insensitive test path
W3:5	–5VA	Negative operating voltage for the choppers
W3:6 W3:7	CH2	Output of the medium test path
W3:8	+5VA	Positive operating voltage for the choppers
W3:9 W3:10	CH1	Output of the most sensitive test path

The casing of the detector is at ground potential.

Analog Board

The analog board A2 contains three test channels of the same design, each consisting of an instrumentation amplifier, a buffer amplifier and a 14-bit A/D converter. The instrumentation amplifiers amplify the output difference voltage of the detectors and convert it into a ground-referenced voltage. The buffer amplifiers are quickly settling operational amplifiers with negative current feedback; they isolate the instrumentation amplifiers from the current peaks occurring at the A/D converter inputs. The A/D converters operate on the successive approximation principle. They have serial outputs.

The serial output data streams of the A/D converters are subjected to serial-parallel conversion in a CPLD and stored in three addressable registers. The digital board consecutively addresses and reads out these registers.

The analog board also comprises an 8-bit D/A converter for generating a noise-line large-scale dither signal that is controlled by the digital board with a sequence of pseudo-random digital values.

The analog board contains a four-channel 12-bit A/D converter for measuring the substrate temperature of the detector as well as for monitoring the operating voltages ± 5 V and +1.75 V. The 12-bit A/D converter is supplied by the 3.3 V operating voltage of the digital board and is thus operational even if the voltage supply of the analog board is defective. It is connected to the synchronous serial interface of the digital board and utilizes the MICROWIRE™ protocol.

The +5 V operating voltage of the analog board is generated from +3.3 V by a charge pump doubler with subsequent linear regulator. The 5 V operating voltage is generated by a switching regulator with a very low output ripple voltage.

Digital Board

The digital board A1 mainly consists of a controller based on a microcontroller Intel StrongARM SA1110, two SRAMs (together 1 Mbyte) as random access memory and two flash PROMs (together 2 Mbyte).

The interface to the R&S NRP base unit is formed by connector X1 on the digital board. Besides the four lines for the USB interface, the sensor cable contains two signal lines for applying a differential trigger signal.

The connection to the analog board is established by press-in connector X2.

The digital board contains two DC/DC converters that generate the voltages +3.3 V and +1.75 V (for the microcontroller core) from the +5 V operating voltage.

Module Replacement

The following section describes how to exchange the plastic shell halves and how to replace the connecting cable. If one of the electronic modules (microwave detector, analog board or digital board) is defective, the sensor has to be sent to Rohde & Schwarz Central Service for repair.



Caution!

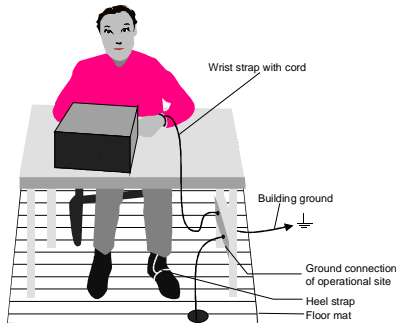

- *Observe the safety instructions at the beginning of this manual.*
- *To avoid damaging electronic components, the instrument should only be opened on a workplace protected against electrostatic discharges.*

The following methods can be used separately or combined to ensure protection against electrostatic discharges:

- *Anti-static wrist strap with grounding cable.*
- *Conductive flooring with foot strap.*

Tools Required

Torx screwdriver	Size	T8
	Thread	M 2.5



Note:

The numeric values in brackets refer to the item in the list of mechanical parts and spare parts in section 5.

These items are identical to the item numbers in the drawings illustrating the module replacement.

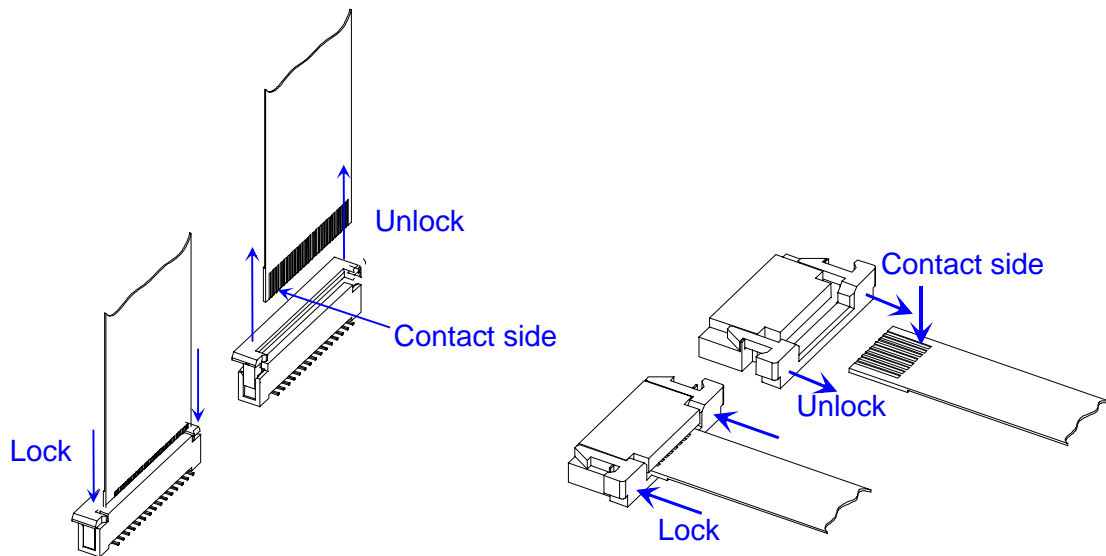

Fig. 3-2 Membrane cables



Note:

Remove membrane cables:

Membrane cables can be removed after unlocking the female connector.

Connect membrane cables:

Observe the contact side and lock the female connector.

List of Modules

Table 3-2 List of modules/spare parts for R&S NRP-Z11 and R&S NRP-Z21

Item No.	Designation	Electrical identification	Stock No.
20	ANALOG BOARD	A2	**)
40	POWER SENSOR CABLE	W1	1137.7141.02
60	SCREW 7985/ISR-M2X8-A4 FOR POWER SENSOR CABLE W1		1148.2600.00 *)
80	DIGITAL BOARD	A1	**)
90	SCREW 7985/ISR-M2X10-A4 FOR DIGITAL BOARD A1		1148.2917.00 *)
100	18 GHZ DETECTOR (NRP-Z21)	A3	**)
101	8 GHZ DETECTOR (NRP-Z11)	A3	**)
150	SHIELDING		1137.6068.00 *)
160	SENSOR HOUSING		1137.6022.00
170	SCREW 7985/ISR-M2X8-A4 FOR OUTER CASING		1148.2600.00 *)
180	LABEL 1 R&S NRP-Z11		1138.3033.00
190	LABEL 2 R&S NRP-Z11		1138.3040.00
200	LABEL 1 R&S NRP-Z21		1137.6039.00
210	LABEL 2 R&S NRP-Z21		1137.6045.00

*) Available but not maintained in spare parts stock, i.e. delivery time may be longer.

***) Spare part not available; to be replaced only by Rohde & Schwarz Central Service.

Opening and Reassembly (Exchange of Plastic Shell Halves)

Opening

- Undo two screws (170) on the two sides of the cable connector.
- First pull off the plastic shell halves of the cable connector and take them apart by twisting them at the RF connector.
- The shielding is attached by a catch of the body on the RF connector side. Slightly bend and unlock the shielding by firmly pressing on the two slim sides and pull it off in the cable direction.

Reassembly

- Push the shielding and lock it into the catch of the body.
- Insert the sensor into one of the shell halves and lock the second shell half on the RF connector side and close at the cable connector.
- Attach the shell halves to the body using two screws (170).

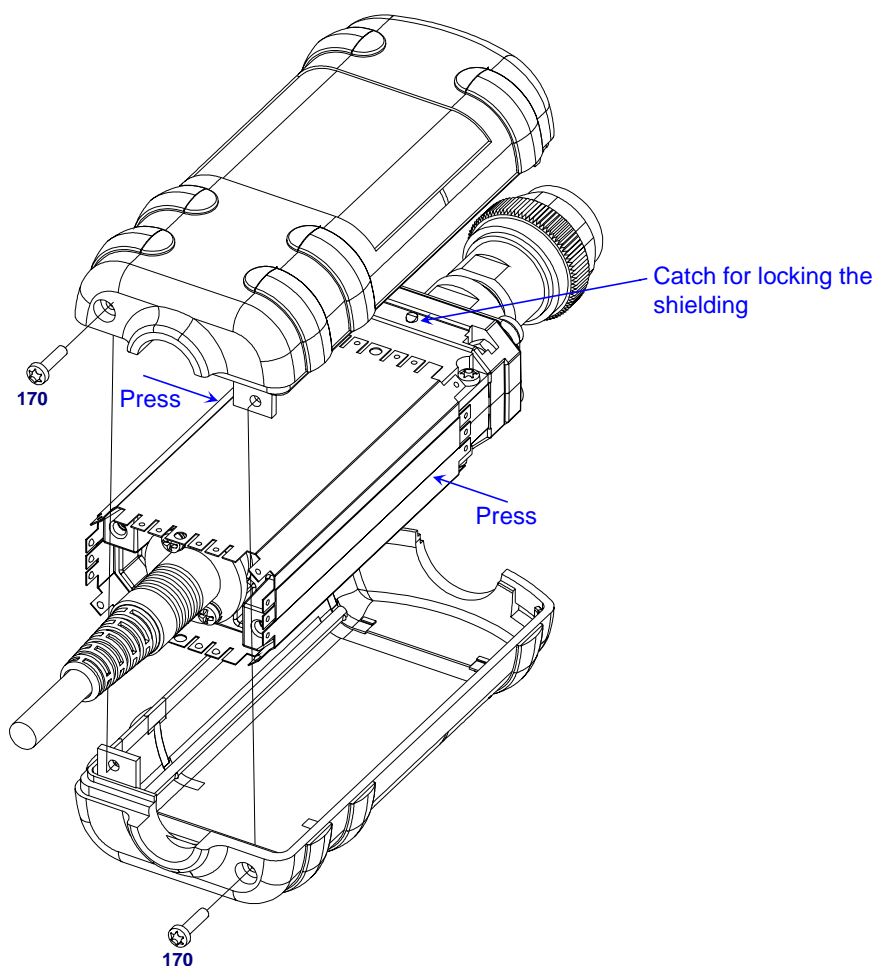

Fig. 3-3 Opening the sensor



Caution:

Observe a torque of 29 Ncm for all screws.

Replacement of Sensor Cable W1

Removing the Sensor Cable

- Opening the sensor (see page 3.7).
- Undo 6 screws (90).
- Carefully remove digital board A1 from the body.
- Unplug sensor cable W1 from digital board.
- For removing sensor cable W1, undo two screws (60) and remove the cable from the body.

Installing the Sensor Cable

- Install in the reverse order.
- Ensure that the guide pins of press-in connector X2 lock into the corresponding boreholes of the digital board.

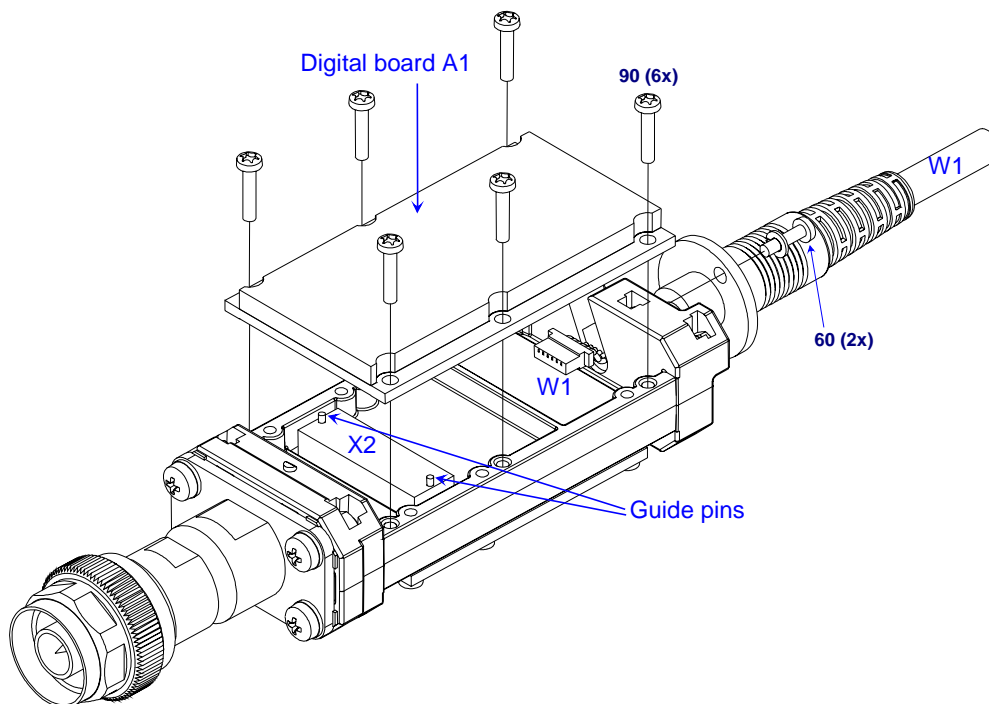

Fig. 3-4 Replacement of sensor cable

Troubleshooting

Malfunctions may sometimes be due to simple reasons but may also result from defective components.

These troubleshooting instructions permit malfunctions or errors to be traced down to module level.

Module replacement and further diagnosis of errors or malfunctions should be carried out by our customer service. It is therefore recommended to send the unit to the nearest service center (see list of addresses at the beginning of this manual).

**Caution:**

Prior to opening sensor and replacing modules, disconnect sensor from base unit (R&S NRP) or USB adapters (R&S NRP-Z3 or R&S NRP-Z4).

Overview of Errors, Causes and Corrective Steps

This section provides an overview of possible errors, their causes and corrective steps.

Problems when plugging in the sensor or switching on the R&S NRP base unit

- **Error: The power sensor is not found (neither measured values nor error messages are displayed on the R&S NRP base unit).**

Troubleshooting instruction	Potential error source and further corrective steps
Unplug sensor from base unit and check male and female connector for damage.	Defective connection. <i>Replace the sensor cable and/or the connector in the R&S NRP.</i>
⇓	
Check whether the error also occurs on another base unit or in another channel.	Error source within base unit. <i>Refer to chapter 3 of the R&S NRP service manual for detailed troubleshooting.</i>
	Error source within sensor. Open sensor and check connection of sensor cable W1 with digital board. <i>Exchange sensor cable.</i> <i>Send sensor in for repair (digital board possibly defective).</i>

- **Error: The R&S NRP base unit has detected an error (pop-up window contains error message, e.g. *Sensor communication error*).**

Troubleshooting instruction	Potential error source and further corrective steps
⇓	
Load current firmware into sensor and base unit according to section 4.	Base unit and sensor cannot communicate with each other. The firmware versions may not be compatible. <i>If updated firmware does not correct problem, perform the same measures as described above (sensor is not found).</i>

- **Error:** The power sensor has detected an error (*HW Error* displayed at extreme right of title bar).

Troubleshooting instruction	Potential error source and further corrective steps
<p style="text-align: center;">⇓</p> <p>Check whether error also occurs on a different base unit.</p>	<p>The sensor detected an error during selftest or during communication (hardware defect or defective voltage supply).</p> <p>Error source within base unit. <i>Refer to chapter 3 of the R&S NRP service manual for detailed troubleshooting.</i></p> <p>Error source within sensor. <i>Send sensor in for repair (analog board or digital board is defective).</i></p>

Problems during measurement

- **Error:** Measured power readings are erroneous.

Troubleshooting instruction	Potential error source and further corrective steps
<p>Perform performance test or selftest according to section 1.</p>	<p>Sensor was overloaded: indicated by very poor matching and/or errors in measurement path 1. <i>Send sensor in for repair (microwave detector is defective).</i></p> <p>Other parts of sensor hardware are defective. <i>Send sensor in for repair (microwave detector or analog board is defective).</i></p> <p>Sensor hardware is probably ok since test limits are only slightly exceeded. <i>Perform update of calibration factors in data memory of sensor according to section 2.</i></p>

4 Firmware Update/Installation of Options

Chapter 4 provides information on the software update and the installation of options. Descriptions enclosed with the software update or options can be filed here.

Installation of New R&S NRP-Z11/-Z21 Software

Use the Firmware Update program module to load new firmware for the Power Sensors R&S NRP-Z11 and NRP-Z21. The module is part of the R&S NRP Toolkit that is supplied on a CD-ROM together with the power sensors and enables you to update the boot loader and the application firmware.

The current firmware versions can be downloaded from the R&S homepage on the Internet, since the CD-ROM accompanying the power sensors contains the firmware status at the time of delivery.

Hardware and software requirements

The system requirements for a firmware update are the same as for the operation of the power sensor on a PC (an update via the power meter is not possible):

- PC with free USB port.
- USB Interface Adapter R&S NRP-Z3 or R&S NRP-Z4.
- Operating system Windows™ 98, Windows™ ME, Windows™ 2000, or Windows™ XP.
- **The R&S NRP Toolkit software must already be installed on your PC.**
- One of the following files must be selected (depending on the software component to be updated):
 - <Type>_Sensor<Version Number>.nrp Application
 - Bootloader_<Version Number>.nrp, Boot loader

The files are available in the \software\firmware\sensors directory of the CD-ROM.

Preparation

- Connect the R&S NRP power sensor to the PC using one of the two USB interface adapters.
- If a second R&S NRP-Z power sensor or an R&S NRP is connected to the PC, unplug these devices from the PC.
- Shortly afterwards, the PC should have identified the new USB hardware and assigned the appropriate driver from the **R&S NRP Toolkit** to the power sensor (brief message in a small window).



If you forgot to install the R&S NRP Toolkit beforehand, Windows will try in vain to find a USB driver for the power sensor. If this happens, the R&S NRP-Zxx is highlighted by a yellow exclamation mark in the Windows device manager. In this case, proceed as follows:

- *Abort the dialog for driver installation.*
 - *Install the R&S NRP Toolkit from the CD-ROM.
Then manually assign the USB driver from the toolkit to the power sensor.*
 - *Go to Control Panel – Add/Remove Hardware and start the hardware assistant to search for new components.*
 - *Mark the R&S NRP-Zxx in the list of hardware components and complete the driver installation.*
 - *Unplug the power sensor and reconnect it.*
-

Updating the application firmware



NRP_Z21_Messkopf_0
1_15.nrp



The update can be started as follows:

- Either double-click the icon of the update file named <Type>_Messkopf_<Version Number>.nrp
- Or start **NRP Toolkit – Firmware Update** from the Windows Start menu.

The dialog box on the left is displayed next.

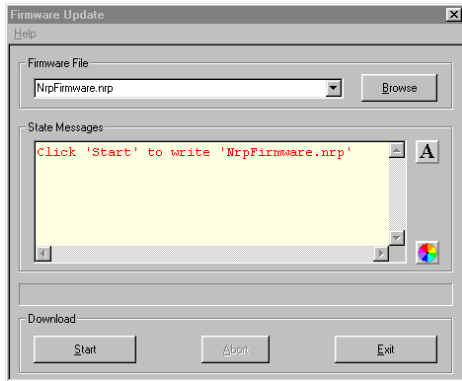

- If the update was started via the Windows Start menu, enter the file name of the application firmware in the **Firmware File** box (or search for the name by using the **Browse** button).
- Click the **Start** button to start the file transfer, which is performed automatically.

- Observe the following:

- Do not disconnect the power sensor from the PC.
- Neither connect nor disconnect the power supply for the R&S NRP-Z3 adapter.
- Exit the Firmware Update program only after it has been completely executed.

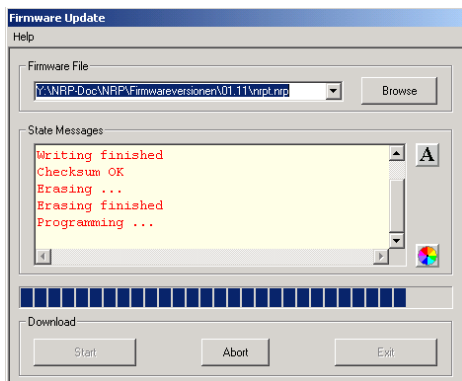

- During the update, the State Messages box informs you of the progress. The update has been completed successfully if the message 'Device <Type Designation><Serial Number> is active' appears.
- You can then use the power sensor for measuring.

Potential problems

- Error in the compatibility and consistency checks.

In this case, the update is aborted and an error message is output.

- Unplug the power sensor, reconnect it and start the update again.



Updating the boot loader



Bootloader_00_20.
nrp



The boot loader update is similar to the update of the application firmware (see above).

- Instead of the application, however, you must load the new boot loader named

Bootloader_<Version Number>.nrp

Strictly observe the warnings under "Updating the application firmware", since the destruction of the boot loader will generally require a repair of the power sensor.

Potential problems

- The power sensor cannot be accessed after the update (error message).
 - Exit the Firmware Update program, unplug the power sensor from the PC and reconnect it. The power sensor is now ready for operation.
-

5 Documents

This section provides information for ordering spare parts and contains the relevant documents for the Rohde & Schwarz Power Sensors R&S NRP-Z11 and R&S NRP-Z21.

Shipping of Instrument and Ordering of Spare Parts

Please contact your Rohde & Schwarz support center or our spare parts express service if you need to request service, repair your equipment, or order spare parts and modules.

The list of Rohde & Schwarz representatives and the address of our spare parts express service are provided in the front section of this service manual.

You will need to provide the following information in order for us to respond to your inquiries quickly and accurately and to determine whether the warranty for your instrument is still valid:

- Instrument model
- Serial number
- Detailed error description in case of repair
- Contact partner for checkbacks

Shipping of Instrument

When shipping the instrument, be sure to provide sufficient mechanical and anti-static protection:

- Repack the instrument as it was originally packed. The antistatic packing foil prevents unintentional electrostatic charging from occurring.
- If you do not use the original packaging, include sufficient padding to prevent the instrument from slipping inside the package. Wrap antistatic packing foil around the instrument to protect it from electrostatic charging.

Ordering Spare Parts

To deliver replacement parts promptly and correctly, we need the following information:

- R&S stock number (refer to the spare part lists in this section)
- Designation
- Number of units
- Instrument type for the replacement part
- Contact person for possible questions

The R&S stock number to be used when ordering replacement parts and modules as well as power cables can be found further below.

Ordering Replacement Sensors

Rohde & Schwarz maintains a replacement program for a number of power sensors. Within this program, it is possible to provide a fully operational power sensor to replace a defective one at short notice and at a fixed price. Please note that replacement sensors are used equipment but are always tested. They are therefore equivalent to new sensors even though they may exhibit slight signs of use. If required, the delivery of replacement sensors can include a new calibration. If interested, please contact your nearest Rohde & Schwarz office.

Spare Parts

The R&S stock numbers necessary for ordering replacement parts and modules can be found in the spare part lists provided below.

List of R&S NRP-Z11/-Z21 Spare Parts

The following table lists available spare parts together with their R&S stock numbers.

Item No.	Designation	Electrical identification	Stock No.
20	ANALOG BOARD	A2	**)
40	POWER SENSOR CABLE	W1	1137.7141.02
60	SCREW 7985/ISR-M2X8-A4 FOR POWER SENSOR CABLE W1		1148.2600.00 *)
80	DIGITAL BOARD	A1	**)
90	SCREW 7985/ISR-M2X10-A4 FOR DIGITAL BOARD A1		1148.2917.00 *)
100	18 GHZ DETECTOR (NRP-Z21)	A3	**)
101	8 GHZ DETECTOR (NRP-Z11)	A3	**)
150	SHIELDING		1137.6068.00 *)
160	SENSOR HOUSING		1137.6022.00
170	SCREW 7985/ISR-M2X8-A4 FOR OUTER CASING		1148.2600.00 *)
180	LABEL 1 R&S NRP-Z11		1138.3033.00
190	LABEL 2 R&S NRP-Z11		1138.3040.00
200	LABEL 1 R&S NRP-Z21		1137.6039.00
210	LABEL 2 R&S NRP-Z21		1137.6045.00

Note: The reference can be found in the drawings 3-3 and 3-4 in Section 3.

*) Available but not maintained in spare parts stock, i.e. delivery time may be longer.

***) Spare part not available; to be replaced only by Rohde & Schwarz Central Service.