



ROHDE & SCHWARZ

Test and Measurement
Division

Service Manual

SMY01

9 kHz to 1040 MHz
1062.5502.11

SMY02

9 kHz - 2080 MHz
1062.5502.12

SMY43

9 kHz to 2080 MHz
1062.5502.43

Volume 1
Service manual consists of 2 volumes

Printed in the Federal
Republic of Germany

Contents

Volume 1

Safety Instructions Supplement

6 Repair of Complete Instrument

7 Testing and Repair of Modules

Module	Tabbed Divider
A2 CPU.....	1
A1 Display- Keyboard	2
A4 Synthesizer	3
A5 Output Unit 1.04 GHz.....	4

Volume 2

Safety Instructions

Module	Tabbed Divider
A5 Output Unit 2.08 GHz.....	1
A6 Attenuator 1 GHz.....	2
A6 Attenuator 2 GHz.....	3
A7 Power Supply.....	4
A8 Reference Oscillator	5
A12 Power Module	6

Safety Instructions

This unit has been designed and tested according to the standards outlined overleaf and has left the manufacturer's premises in a state fully complying with the safety standards.

In order to maintain this state and to ensure safe operation, observe the following instructions, symbols and precautions.

- 1) When the unit is to be permanently cabled, first connect protective ground conductor before making any other connections.
- 2) Built-in units should only be operated when properly fitted into the system.
- 3) For permanently cabled units without built-in fuses, automatic switches or similar protective facilities, the AC supply line shall be fitted with fuses rated to the units.
- 4) Before switching on the unit ensure that the operating voltage set at the unit matches the line voltage.
If a different operating voltage is to be set, use a fuse with appropriate rating.
- 5) Units of protection class I with disconnectible AC supply cable and plug may only be operated from a power socket with protective ground contact.
The protective ground connection should not be made ineffective by an extension cable.
Any breaking of the protective ground conductor within or outside of the unit or loosening of the protective ground connection may cause the unit to become electrically hazardous.
The protective ground conductor shall not be interrupted intentionally.
- 6) Before opening the unit, isolate it from the AC supply.
Adjustment and replacement of parts as well as maintenance and repair should be carried out only by specialists approved by R & S.
Observe safety regulations and rules for the prevention of accidents.
Use only original parts for replacing parts relevant to safety (e.g. power on/off switches, power transformers or fuses).
- 7) Also observe the additional safety instructions specified in this manual.

Explanation of Symbols Used



- Read operating manual, observe the safety symbols used



- Caution, shock hazard



- Protective ground connection



- Unit ground



- Equipotential (floating ground)



- Ground

Patent Information

This product contains technology licensed by Marconi Instruments LTD. under US patents 4609881 and 4870384 and under corresponding patents in Germany and elsewhere.

**Supplement
to Service Manual
SIGNAL GENERATOR
SMY43
1062.7805.43**

For model SMY43 the following limit values are valid for diagnostic points or module tests:

1. 1062.5502 Chapter 6.3.1.2
Table:
Diagnostic point 15 (Sp.fct.115): max. .5V, max. 21.5V
2. 1062.6409 Chapter 7.4.4
VCO control voltage continuously rising from about 1V to about 20V in frequency range
780.000 001 to 1040MHz
3. 1062.6409 Chapter 7.4.4
Table:
VCO2 RF900MHz, 780MHz min. 1V, 1040MHz max. 21V
4. 1062.6409 Chapter 7.4.5.4
Table:
780MHz 1V to 2V
1040MHz 18.5V to 21V
5. 1062.5502 Chapter 7.4.13.1
Diagnostic point 15: min. .5V, max. 21.5V

Contents

6 Repair	5
6.1 List of Modules and Function Description	5
6.1.1 Synthesis.....	5
6.1.2 Output Unit.....	6
6.1.3 Controller.....	6
6.1.4 Keyboard and Display.....	6
6.1.5 Attenuator.....	6
6.1.6 Reference Oscillator (Option).....	6
6.1.7 Pulsmodulator and High Output Power (Option).....	7
6.2 Test Instruments and Utilities	7
6.3 Troubleshooting	7
6.3.1 Utilities Installed.....	7
6.3.1.1 Self-Monitoring, Error Message.....	7
6.3.1.2 Diagnosis.....	9
6.3.1.3 List of Special Functions.....	11
6.3.2 Module Test with Internal Diagnosis.....	11
6.3.2.1 Troubleshooting on Individual Modules.....	12
6.3.3 Troubleshooting Acc. to the Type of Error.....	14
6.3.3.1 Frequency Error.....	14
6.3.3.2 Level Error.....	14
6.3.3.3 AM Error.....	14
6.3.3.4 FM/φM Error.....	14
6.3.3.5 Level of Harmonics too High.....	14
6.3.3.6 Poor Spectral Purity.....	14
6.4 Testing and Adjustment	15
6.4.1 Calibration Routines.....	15
6.4.1.1 VCO Calibration.....	15
6.4.1.2 FM Calibration.....	15
6.4.1.3 Calibration of FM-DC Center Frequency.....	16
6.4.1.4 Level Preset.....	16
6.4.1.5 Output Level Correction.....	16
6.4.1.6 Calibration of Reference Oscillator.....	17
6.4.2 Adjustment of the Overall Instrument.....	18
6.4.3 Adjustments Following Replacement of Modules.....	18
6.5 Disassembly and Assembly	19
6.5.1 Removal and Installation of the Panelling.....	19
6.5.2 Removal and Installation of the Controller.....	19
6.5.3 Removal and Installation of the Output Unit.....	19
6.5.4 Removal and Installation of the Synthesis.....	20
6.5.5 Removal and Installation of the Keyboard/Display....	20
6.5.6 Removal and Installation of the Power Supply.....	20
6.5.7 Removal and Installation of the ROSC Option.....	21
6.5.8 Removal and Installation of the Power Module.....	21

List of mechanical parts
Exploded View
List of keys
List of power cables
Cross-reference list
Parts list
List of coordinates
Circuit diagram
Component layout diagram

6.1 List of Modules and Function Description

	Module German/	English	Abbreviation	Part No
A1	Tastatur/Anzeige	Keyboard/Display	FRONT	1062.6809
A2	Rechner	Controller	CPU	1062.6309
A4	Synthese	Synthesis	YSYN	1062.6409
A5	Ausgangsteil 1GHz	Output Unit 1GHz	OPUY01	1062.6209
	Ausgangsteil 2GHz	Output Unit 2GHz	OPUY02	1062.7005
A6	Eichleitung	Attenuator 1GHz	ATT01	0826.5065
	Eichleitung	Attenuator 2GHz	ATT02	0801.1108
A7	Netzteil	Power Supply	POW	1062.5690
Options:				
A8	SMY-B1	Referenzoszillator	Reference Oscillator	ROSC
				1039.1027
A12	SMY-B40	Pulsmodulator und	Pulse Modulator and	PMOD
		High Output Power	High Output Power	1062.9008

The following text refers to the functional circuit diagram 1062.5502.01FS and circuit diagram 1062.5502.01S.

The SMY 01/02 synthesizes the basic octave from 520 to 1040 MHz, which all other frequencies are derived from by division, mixing or by doubling as is the case with SMY02.

A single-loop-synthesizer generates the basic octave without synthesis error using a fractional divider with a resolution of 1 Hz. The frequency extension by division, mixing and doubling is followed by level conditioning and the mechanical attenuator.

6.1.1 Synthesis

The output oscillators are synchronized in a PLL to the reference frequency 2 MHz by means of a fractional divider. Two RF dividers with the factors two and four extend the frequency range up to 65 MHz.

The frequency range below 65 MHz is generated by down-conversion using a 640-MHz oscillator.

The circuit contains a 10-MHz TCXO as standard reference. A reference PLL allows for synchronizing to an external reference frequency. The spectral purity close to the carrier can be improved by synchronizing to an optional OCXO.

The frequency modulation for low frequencies is effected via the division factor and thus via the PLL. In the case of high modulation frequencies, the oscillators are directly modulated. A flat frequency response is obtained if the two modulation paths have the same sensitivity and delay.

The phase modulation is obtained by differentiating the modulation signal.

6.1.2 Output Unit

The signal of the synthesis in the frequency range from 65 to 1040 MHz is passed via an amplitude modulator and an amplitude control element to a switchable filter bank. A changeover switch selects either the direct signal path via the output amplifiers to the level detector and to the output socket or a second path, which generates the frequency range from 9 kHz to 65 MHz by down-conversion with the 640-MHz LO signal. For frequencies below 10 MHz, a second RF detector at the RF signal path of the mixer is activated for level control. The SMY02 provides a third path, which generates the output frequency range above 1040 MHz by doubling.

6.1.3 Controller

A processor takes control of the overall instrument. The program memory consists of EPROMs and a battery-backed RAM. The diagnostic voltages are measured by an A/D converter which is integrated in the CPU. Series-connected operational amplifiers allow for switching over the amplification between $V=1$ and $V=16$. In addition, the controller module accommodates the AF synthesizer 1 - 500 kHz which has been realized as DDS component. The external LOW-HIGH monitoring logic and the channel switchover for the AM are also integrated.

6.1.4 Keyboard and Display

This module contains the keyboard and the keyboard matrix. LEDs indicate the input parameter selected and signal the output of error messages. A spinwheel allows for continuous variation of a selected parameter. Two LCD displays are provided for display of frequency, level and the modulation and AF-frequency settings.

6.1.5 Attenuator

The mechanical attenuator extends the adjustable level range by 130 dB in the case of SMY01 and 135 dB for SMY02. An overvoltage protection for dc and ac voltages, which protects the output against externally applied voltages, has been integrated. It consists of a detector, a limiter and a mechanical isolating switch, which is directly actuated by the attenuator control. This isolating switch adopts the open position with switching off the instrument.

6.1.6 Reference Oscillator (Option)

The optional oven-controlled crystal oscillator may be used as reference to improve the long-term stability and the residual FM close to the carrier. A 12-bit D/A converter on the synthesis allows for adjusting the module to 10 MHz. An identification circuit on the module enables the controller to identify with switch-on, which position the corresponding switches on the synthesis assume and whether the integrated TCXO is used as reference for synchronization.

If an external reference is used for synchronization, the TCXO on the synthesis is operated, such that the residual FM can not be improved by the oven-controlled crystal oscillator.

6.1.7 Pulse Modulator and High Output Power (Option)

This option increases the output level of the SMY up to 19 dBm (25dBm overrange). The pulse modulator switches the RF signal faster than 20 ns. It is controlled via an external TTL signal from the rear panel. When fitting or removing this option, the modules output unit, attenuator and motherboard are modified. Fitting or removing the option is only possible at the factory or at authorized service centers.

6.2 Test Instruments and Utilities

1. Controller acc. to industrial standard PC/XT/AT with IEC-625/IEEE488 interface for remote control and connecting cable for IEC/IEEE bus. Rohde&Schwarz Basic and the corresponding IEC/IEEE-bus drivers must be installed.
2. Program floppy disk containing service programm 'SMYSERVI.BAS'.
3. RF power meter, 5 kHz to 1.04(2.08) GHz, e.g., R&S NRVS(1020.1809.02) with power sensor NRV-Z51(875.9004.02).

6.3 Troubleshooting

6.3.1 Utilities Installed

Internal measuring points are provided on the modules YSYN and OPUY01/02 for self-monitoring and service purposes. The most important of them trigger an internal alarm when limits are exceeded, all points can be measured on the controller module via multiplexers and a A/D converter.

The control voltages and output levels are internally measurable on the modules. In addition, test points are provided for adjustment purposes and at locations which are important for the signal flow, where external measurement would be difficult.

6.3.1.1 Self-Monitoring, Error Message

If the control voltage within a control loop exceeds the permissible range, an alarm is triggered on the controller and indicated on the display. It may be due to missing calibrations, maloperation, violation of the specified setting parameters (e.g., level) or internal faults.

Elimination of errors should be carried out according to the below-mentioned order, since the errors could be sequential errors of the upper errors.

If the controller receives an alarm message, the status LED blinks. In case of range violation of the specification (e.g., level 19 dBm or > 19 dBm with option SMY-B40) the LED normally lights up. When the status key is actuated, the error or overrange can be further specified by an error code in the right display.

Status codes of errors and overrange/underrange settings:

Status code	Meaning
0	no error
Function errors	
1	10-MHz reference loop out of synchronization
2	640 MHz loop out of synchronization
3	Main-oscillator loop out of synchronization
4	Level control does not work
5	External overvoltage at RF output
6	ROM-data error
7	RAM-data error of the stored settings
8	RAM-data error of VCO correction values
9	RAM-data error of FM correction values
10	RAM-data error of LEVEL PRESET correction values
11	EEPROM-data error of RF-level correction values
12	EEPROM data error of REF-OSC correction values
15	Calibration not possible
Faulty entries	
50	Syntax error
51	Entered value out of permissible range
52	Unit not permitted for selected parameter
53	Header not permitted (IEC/IEEE bus)
54	AF synthesizer can not be switched off with internal modulation switched on
55	FM deviation too large for selected RF
56	Variation not enabled, if the corresponding parameter is not switched on (IEC/IEEE-bus)
57	Calibration of FM-DC center frequency only with FM DC
Overrange/Underrange settings	
70	AM not specified with the level set
71	AM not specified for AF > 50 kHz
72	RF < 9 kHz
73	AM EXT signal out of tolerance
74	FM/φM EXT signal out of tolerance
75	φM not specified for AF < 20 Hz or AF > 20 kHz
76	AF > 500 kHz
77	Level > 13 dBm or > 19 dBm with option SMY-B40
78	OVEN COLD

Table about possible error causes for status message:

Type of error	Possible error cause
Error message "Err. 1" 10-MHz reference loop out of synchronization	External reference selected, however, frequency not within pulling range or level too small.
Error message "Err. 2" 640-MHz loop out of synchronization	640-MHz LO does not supply any signal
Error message "Err. 3" Main-oscillator loop out of synchronization	RF oscillators do not supply any signal Reference signal missing (int. or ext.) Modulation signal with FM ext. > 1V _{SS}
Error message "Err. 4" Level control does not work correctly	Level overrange AM overrange Overrange with AM EXT DC 'Level-Preset' calibration faulty
Error message "Err. 5" External overvoltage at RF output	Applied RF level too high Applied dc voltage too high Open circuit at RF socket with level overrange

6.3.1.2 Diagnosis

Since the voltage range of the multiplexers is limited to ± 5 V, voltage dividers are required at many diagnostic points. The controller takes this scaling factor into account such that the correct value prior to the voltage divider is displayed.

The test points mentioned below can be selected in order to further localize a possible error. The indicated voltages are recommended values for a properly-working instrument. They are displayed via special functions and can be read by a controller via the IEC/IEEE bus.

The diagnosis provides an amplification switchover $v=16$ for exact determination of low voltages. It is controlled by autoranging which switches over at 200 mV and displays the result with three decimals in 'mV'. The resolution of the diagnosis is 10 mV with amplification $v=1$ and 0.6 mV with amplification $v=16$.

Diagnosis OPUY 01/02							
Diag. point	Special function	Test point	Description	IR [V]	min [V]	max [V]	Tf
0	101	Diagnd	Ref 10kOhm with SMY01		-.03	+.03	1
		Udoubler	RF level at doubler with SMY02	+1	+5.	3	
1	102	Vdet	Detector output FOPU1/2		+1	+5.	3
2	103	Vdetmix	Detector in the mixer path		+1	+5.	3
3	104	Vdetfilt	Detector subsequent to filter				
4	105	Urf_soll	Level control voltage		+2	3.	3
5	106	Uregelverst	Voltage subsequent to control amplifier	X	-6.	0.	3
6	107	Umodulator	Control voltage of AM modulator		-15	0.	3
7	108	Ustellglied	Control voltage 'Level-Preset'		-15	0.	3

Diagnosis YSYN							
Diag. point	Special function	Test point	Description	IR	min [V]	max [V]	Tf
9	109	R146	Reference 10kOhm		-.05	+.05	1
10	110	10Ref	10-V reference voltage		9.9	10.1	3
11	111	Pll-VTCXO	Control voltage of VTCXO referemce	X	3.0	4.7	3
12	112	Pll-640	Control voltage of 640-MHz LO	X	4.0	17.0	5
13	113	Ref-640	Level 640-MHz VCO on		.1	.6	1
			off		-	.05	
14	114	FSYN	Output level FSYN		.60	1.0	1
15	115	Pll-FSYN	Control voltage VCO's FSYN	X	1.75	21.5	5
16	116	FM-Cal	Difference deviation detector, 1kHz		0.	.05	3

The column 'IR' indicates, whether a diagnostic point may trigger an interrupt (cf. list of status codes 6.3.1.1)

6.3.1.3 List of Special Functions

Special functions	Code	Remote control command
Non-interrupting level setting	1	ATTENUATOR:FIXED
Normal level setting	2	ATTENUATOR:NORMAL
Level EMF	3	LEVEL:EMF
Normal level	4	LEVEL
AM dual-tone	5	AM:DUAL
AM normal	6	AM
FM/φMm dual-tone	7	FM:DUAL (e.g., FM)
FM/φM normal	8	FM (e.g., FM)
BLANK on	9	BLANK:ON
BLANK off	10	BLANK:OFF
BLANK polarity inverted	11	BLANK:INVERTED
BLANK polarity normal	12	BLANK:NORMAL
ALC bandwidth narrow	13	SPECIAL 13
ALC bandwidth automatically adapted	14	SPECIAL 14
ALC bandwidth broad	15	SPECIAL 15
ALC bandwidth automatically adapted	16	SPECIAL 16
Set power-on-clear-flag	17	
Delete power-on-clear-flag	18	
User request	19	
Switch ALC off	21	ALC:FIXED
Switch ALC on	22	ALC:NORMAL
AM invers	23	SPECIAL 23
AM normal	24	SPECIAL 24
RF Output Impedanz "OPEN" bei Level	25	SPECIAL 25
RF Output Impedanz "50 Ω" bei Level	26	SPECIAL 26
Display firmware version	29	
Display test	31	SPECIAL 31
ROM test	33	SPECIAL 33
RAM test	35	SPECIAL 35
EEPROM test	37	SPECIAL 37
All internal calibrations (SPECIAL 41/43/45)		
VCO calibration routine	41	SPECIAL 41
FM calibration routine	43	SPECIAL 43
LEVEL PRESET calibration routine	45	SPECIAL 45
Calibration RF level on	47	SPECIAL 47
Terminate calibration of RF level	48	SPECIAL 48
Level correction off	49	LEVEL:CORRECTION:OFF
Level correction on	50	LEVEL:CORRECTION:ON
Calibration REF-OSC on	51	SPECIAL 51
Terminate calibration REF-OSC	52	SPECIAL 52
Calibration routine FM-DC center frequency	55	SPECIAL 55
Switch off diagnostic test point	100	TEST:OFF
Switch on diagnostic test point	101-116	TEST:POINT 1 (zB. Punkt 1)

6.3.2 Module Test with Internal Diagnosis

The diagnostic points are selected using the special functions 101 to 116. The spinwheel allows for stepping through the diagnostic points. 'Special 100' switches off the diagnosis.

6.3.2.1 Troubleshooting on Individual Modules

Prior to making the given settings, the instruments should assume a defined state by a 'PRESET'. Diagnostic points which are not mentioned in the following should be within the given tolerances independent of the settings.

6.3.2.1.1 Controller, Display and Diagnosis (CPU)

If the instrument does not react upon switching on the power switch, check whether the 5-V supply voltage is within the tolerance range.

If the instrument does not react upon turning the spinwheel or pressing any key, check whether the instrument is set to remote control (IEC bus) or whether any key has got stuck. If this is the case, proceed as described in the service instructions for the keyboard/display module.

To test the diagnosis, the diagnostic points 109 and 110 can be selected, i.e., two voltages which are constant independent of the operating state. Diagnostic point 109 allows for testing the zero point of the diagnosis via a 1-kOhm reference resistance on the synthesis, a 10-V voltage of a regulator on the same module (diagn. pt. 110) allows for determination of the correct scale.

- *The tests described above assume that the synthesis is fitted. The latter must provide a correctly-working 10-V reference for the second measurement.*

If instrument settings (also stored ones) are not retained upon switching on and off, replace the lithium battery on the controller module.

(cf. operating manual, Section 4.1.3)

6.3.2.1.2 Synthesis (YSYN)

Correct synchronization of the synthesis oscillators in CW mode can be checked via the diagnostic point 15 (special function 115).

- Switch on test point 15 on the SMY.
Step through the frequency range from 520 to 780 MHz. The complete tuning range of the first oscillator is thus swept through.
- _ The VCO control voltage must continuously increase from approx. 2 V to approx. 19 V.
- Step through the frequency range from 780.000 001 to 1040 MHz with the test point switched on. The complete tuning range of the second oscillator is thus swept through.
- _ As above, the VCO control voltage must continuously increase from approx. 2 V to approx. 19 V.

6.3.2.1.3 Output Unit (OPUY01/02)

The correct function of the output unit can be checked most easily by checking the modulator voltage.

- Set the SMY01/02 to 10MHz unmodulated, set the level to 13 dBm (19 dBm with option SMY-B40). Select non-interrupting level setting via special function 1 (Spec 1).
- Use special function 49 to switch off the level correction.
- Terminate the RF-output with 50 Ω.
- The voltages given in the table below must be measured with a tolerance of ±10% of the display ±60 mV depending on the output frequency and level.

This measurement requires a valid table of 'Level Preset' values to be stored in the controller. The rated values of the detectors and of the command value for level control are indicated in the table for further error localization.

If the values given in the table are not obtained, the signal level subsequent to the filter bank can be measured via the diagnostic point 3 (Spec. 104). Set the maximum level. With SMY02, the level prior to the modulator of the doubler path can be tested as well.

Without option SMY-B40, the values listed below apply:

Level	Vmodulator		Vdet		Vdetmix	Vrf_soll
	Diagn. pt.6	Diagn. pt.6	Diagn. pt.1	Diagn. pt.1	Diagn. pt.2	Diagn. pt.4
	Spec. 107		Spec. 102		Spec. 103	Spec. 105
[dBm]	f ≤ 1040 MHz	f > 1040 MHz	f ≥ 10 MHz		f < 10 MHz	
			SMY01	SMY02		
13	6.3	7.5	3.3	3.0	9.97	-3.0
7	3.9	5.4	1.65	1.5	4.98	-1.5
0	"	"	.7	.64	2.13	-.64
-6	"	"	.35	.32	1.06	-.32

The detector voltage is a measure for the actual level applied to the output. A correct modulator voltage requires a correct operating point which is determined by the preset level. Faulty calibration thus leads to a modulator voltage which does not correspond to the values given in the table in spite of correct regulation.

With option SMY-B40, the values listed below apply:

Level	Vmodulator		Vdet		Vdetmix	Vrf_soll
	Diagn. pt.6	Diagn. pt.6	Diagn. pt.1	Diagn. pt.1	Diagn. pt.2	Diagn. pt.4
	Spec. 107		Spec. 102		Spec. 103	Spec. 105
[dBm]	f ≤ 1040 MHz	f > 1040 MHz	f ≥ 10 MHz		f < 10 MHz	
			SMY01	SMY02		
19	6.3	7.5	1.8	1.8	2.2	-3.0
13	3.9	5.4	.9	.9	1.1	-1.5
6	"	"	.4	.4	.48	-.64
0	"	"	.2	.2	.24	-.32

- Use special function 50 to switch on the level correction again.

6.3.2.1.4 AF Generator (CPU)

The output level of the AF generator can be tested easily by means of the external High/Low monitoring logic. The AF generator output must only be connected to the FM ext input on the front of the instrument via a short BNC cable.

- Select external FM modulation (FM ext/AC) on the SMY. Set the AF frequency to 1 kHz.

— The external high/low indication in the right display must indicate neither 'High' nor 'Low'.

If the FM-external monitoring logic is assumed to be faulty, the AM-external monitoring logic can be used also. The test procedure must be carried out correspondingly.

6.3.3 Troubleshooting Acc. to the Type of Error

In the following, the errors are grouped acc. to the type of error. The order the boards which are assumed to be faulty are listed corresponds to the signal flow.

6.3.3.1 Frequency Error

A8 Reference Oscillator ROSC (Option)
A4 Synthesis YSYN
A5 Output Unit OPUY01/02

6.3.3.2 Level Error

A5 Output Unit OPUY01/02
A12 Power Module (option SMY-B40) PMOD
A6 Attenuator ATT01/02

6.3.3.3 AM Error

A5 Output Unit OPUY01/02
A12 Power Module (option SMY-B40) PMOD
A2 AF Generator CPU

6.3.3.4 FM/φM Error

A4 Synthesis YSYN
A2 AF Generator CPU

6.3.3.5 Level of Harmonics too High

A5 Output Unit OPUY01/02
A12 Power Module (option SMY-B40) PMOD

6.3.3.6 Poor Spectral Purity

A4 Synthesis YSYN
A5 Output Unit OPUY01/02
A12 Power Module (option SMY-B40) PMOD

6.4 Testing and Adjustment

6.4.1 Calibration Routines

Valid calibration values for the various functions are required for trouble-free operation of the instrument according to the given specifications.

The calibration data of VCO, FM, and LEVEL-PRESET calibrations are stored in the battery-backed RAM of the controller. The calibration data of level correction and reference oscillator are stored in the EEPROM.

Most of the required calibrations are performed internally and do not require any external utility. They can be called by means of special functions.

6.4.1.1 VCO Calibration

The VCO calibration is called via special function 41 and determines the VCO slope of the RF oscillators on the synthesis module. The PLL gain which varies due to the VCO slope and the different dividing factors in the feedback path is compensated for by means of the calibration values.

- *Without valid VCO calibration, it may occur that the transient response with change of frequency and the FM performance are out of the range specified in the data sheet. This routine must be called subsequent to replacement of the modules YSYN or CPU. The instrument should have reached the final operating temperature.*

_ The VCO calibration is initiated by special function 41 (see operating manual). Subsequent to calibration, the previous instrument setting is restored.

6.4.1.2 FM Calibration

With FM calibration, the scales of the two FM-modulation paths (dividing factor via the PLL control and VCO tuning voltage via the control) are mutually adjusted.

- *The VCO calibration must have been called successfully prior to FM calibration in order to receive valid calibration data. Large temperature variations during operation may require the calibration to be repeated (cf. data sheet SMY FM-DC).*

_ The FM calibration is initiated by special function 43 (see operating manual). Subsequent to calibration, the previous instrument setting is restored.

The calibration data are stored in the RAM after successful calibration, which can be repeated any time.

6.4.1.3 Calibration of FM-DC Center Frequency

Normally, it is not absolutely required to call this calibration since the accuracy of the center frequency is very high even without explicitly calling the calibration. However, if the accuracy is to exceed 0.1% of the FM-deviation, this calibration of the FM-DC center frequency can be called via special function. It is automatically performed with first setting of an FM-DC.

- The calibration of the FM-DC center frequency is initiated by special function 55 (see operating manual). It takes approx. 4 seconds.

6.4.1.4 Level Preset

The instrument-specific level preset is performed to ensure that level control always works in the optimum operating point.

- *The AM characteristics worsen if the calibration table is missing or incorrect. Level control may even oscillate. The calibration should be performed after the instrument has reached its operating temperature.*

This calibration is always required after repair or replacement of the controller, synthesis, output unit or option SMY-B40. The synthesis must work correctly for this calibration.

- The level-preset calibration is initiated by special function 45 (see operating manual). Subsequent to calibration, the previous instrument setting is restored.

The calibration data are stored in the RAM after successful calibration, which can be repeated any time.

6.4.1.5 Output Level Correction

The accuracy of the output level is obtained by a level correction according to a table stored in the controller. This table is produced by means of a test program and a calibrated power meter and passed into the EEPROM of the controller via the IEC/IEEE bus. The complete calibration procedure can also be performed manually.

Manual calibration only requires the power meter specified under 6.2, item 3.

Automatic calibration requires the utilities listed in 6.2, items 1 to 3.

6.4.1.5.1 Manual Calibration of Level Correction

- Connect calibrated power meter to RF socket.
- Call special function 47

The first calibration frequency is displayed. By pressing the RF-key the calibration frequencies can be varied, by pressing the LEVEL-key the correction value. The entered value is written into the calibration table by pressing the ENTER-key. The next calibration frequency is displayed automatically. Proceed as above until reaching the last interpolation value. Call special function 48 to store the obtained values in the EEPROM.

- Call special function 48

To quit the actual calibration procedure without storing the entered table in the EEPROM the OFF-key is to be set. In this case the calibration table is for temporary use only.

6.4.1.5.2 Program-controlled Level Calibration

- Connect calibrated power meter to RF socket.
- Connect controller, SMY and power meter to IEC-bus cable.
- Load Rohde & Schwarz-Basic and IEC-bus driver.
- Load and start the service program 'SMYSERVI.BAS'.
- Call the level-correction calibration in the submenu 'Calibrations'.

_ Calibration runs automatically.

6.4.1.6 Calibration of Reference Oscillator

Adjustment is required to ensure the accuracy of the reference frequency with the reference-oscillator option OCXO fitted. A D/A converter on the synthesis generates a tuning voltage which sets the reference oscillator to the correct frequency. The voltages for each individual OCXO have been determined in the factory. The correct tuning voltage is indicated on the label fitted to the cover of the oscillator. This calibration is performed only one time and must only be repeated with replacement of the controller or the reference-oscillator option as well as with ageing of the option.

If the tolerances of the reference-frequency accuracy are violated due to ageing, proceed as described in the service instructions for the reference oscillator.

If the tuning voltage has been re-determined for a special reference oscillator, the D/A converter data stored in the controller does not correspond with the tuning voltage on the reference crystal. In case of replacement of the controller, therefore take the D/A value stored in the previous controller and enter it to the new controller as described below.

- Call special function 51 (Refcal)

The stored value for the D/A converter is displayed in the right display. It may be 0 to 4095 (default 2048). The value for the D/A converter is derived from the tuning voltage as follows:

$$DA \text{ value} = 4095 * (\text{tuning voltage[V]} / 10V)$$

- Enter the calculated value via the spinwheel or the keypad.
- Terminate calibration by calling special function 52.

6.4.2 Adjustment of the Overall Instrument

If the instrument is set up of modules which have been tested and adjusted according to Section 7, the calibrations described in Section 6.4.1 are required, only.

6.4.3 Adjustments Following Replacement of Modules

Replacement of board	Required adjustments
Controller CPU	All adjustments acc. to 6.4.1
Display/Keyboard FRONT	No adjustment required
Synthesis YSYN	VCO calibration acc. to 6.4.1.1 FM calibration acc. to 6.4.1.2 Level-Preset calibration acc. to 6.4.1.4
Output Unit OPUY	Level-Preset calibration acc. to 6.4.1.4 Output-level correction acc. to 6.4.1.5
Attenuator ATT01/02	Output-level correction acc. to 6.4.1.5
With options installed:	
SMY-B40 (Pulse modulator and High Output Power)	Level-Preset calibration acc. to 6.4.1.4 Output-level correction acc. to 6.4.1.5
Reference oscillator ROSC	Calibration of reference frequency acc. to 6.4.1.6

6.5 Disassembly and Assembly

WARNING !!!

Prior to disassembly, switch off the instrument and disconnect the power cable

6.5.1 Removal and Installation of the Panelling

- Undo the four screws in the rear-panel feet and remove feet.
- Remove the upper panelling to the rear and to the top
- Turn around the instrument. Remove the lower panelling similar to the upper panelling.

Prior to installation of the panelling, check, whether all modules are correctly connected and screwed to their supports.

- Place the instrument on one edge and install the lower panelling first. Make sure that the packing cords are correctly fitted into the grooves.
- Place the instrument into the horizontal position again and install the upper panelling, correspondingly.
- *Make sure with both panellings that the guide noses on the rear panel lock into the cut-outs of the panellings.*
- Screw on feet again.

6.5.2 Removal and Installation of the Controller

- Remove the panelling (6.5.1).
- Place the instrument on the top.
- Undo the two screws which fix the module to the support frame.
- Carefully lift the module and turn until the three ribbon cables can be disconnected from the sockets on top of the module.

_ The module can be removed.

Installation is carried out correspondingly in the reverse order.

6.5.3 Removal and Installation of the Output Unit

- Remove the panelling (6.4.1).
- Place the instrument on its bottom.
- Disconnect the three RF cables on the front of the module.
- Undo the two screws which fix the module to the support frame.

_ The module can now be removed to the rear and to the top out of the guide cut-out of the support frame.

Installation is carried out correspondingly in the reverse order.

6.5.4 Removal and Installation of the Synthesis

- Remove the panelling (6.4.1).
 - Place the instrument on its bottom.
 - Remove the controller as described in Section 6.4.2.
 - Detach the RF cables on the front of the module.
 - Undo the two screws which fix the module to the support frame.
- The module can now be removed to the rear and to the top out of the guide cut-out of the support frame.

- Remove the panelling (6.4.1).
 - Place the instrument on its bottom.
- Installation is carried out correspondingly in the reverse order.

6.5.5 Removal and Installation of the Keyboard/Display

- Remove the panelling (6.4.1).
- Place the instrument on its top.
- Remove the controller as described in Section 6.5.2
- Undo the four screws on the front of the display.
- Carefully remove the display to the front. Make sure to lead the ribbon cable which connects the module to the controller through the cut-out of the housing frame.

Installation is carried out correspondingly in the reverse order.

6.5.6 Removal and Installation of the Power Supply

- Remove the panelling (6.4.1).
- Place the instrument on its bottom.
- Disconnect the ribbon cable which connects the module to the motherboard.
- If the reference-oscillator option ROSC is fitted, disconnect the connecting cable to the option, too.
- Undo the screws marked on the rear panel of the instrument.
- Carefully remove the power supply to the rear.

Installation is carried out correspondingly in the reverse order.

6.5.7 Removal and Installation of the ROSC Option

- Remove the panelling (6.4.1).
 - Place the instrument on its bottom.
 - Disconnect the SMB connector, which connects the option to the synthesis, on the reference oscillator option.
 - Disconnect the ribbon cable, which connects the option to the power supply, from the power supply.
 - Undo the four screws which fix the module to the instrument frame. They are accessible on the outside of the instrument.
- _ Remove the reference-oscillator option to the top.

6.5.8 Removal and Installation of the Power Module

- Remove the panelling (6.4.1).
- Place the instrument on its bottom.
- Disconnect both MMCX-connectors and both SMA-screw connections.
- Disconnect the ribbon cable.
- Undo the screws which fix the module to the instrument frame.
- Remove the power module to the top.

When installing the power module, the projecting parts on the PCB must be stucked into the corresponding slots of the middle panel of the instrument. Further installation is carried out correspondingly in the reverse order.



ROHDE & SCHWARZ

**Liste mechanischer Teile
Bilder und Erklärung zur Liste
mechanischer Teile**

**List of mechanical parts
Figures and explanation pertai-
ning to list of mechanical parts**

**Liste des pièces mécaniques
Figures et définitions pour liste
des pièces mécaniques**

Liste mechanischer Teile

List of mechanical parts

Der SMY01 ist in *R&S-Kompaktbauweise 90* aufgebaut.

The SMY01 is designed in accordance with the *R&S design 90*.

Gehäusegröße:
3E, 1/1, T350

Cabinet size:
3E, 1/1, T350

Maße über alles:
435 x 147 x 350 (B x H x T)

Overall dimensions:
435 x 147 x 350 (width x height x depth)

Ergänzungen:
19"-Adapter ZZA
Tragegriff, Nachrüstsatz
(falls ein zweiter Tragegriff gewünscht wird)

Accessories:
19"-Adapter ZZA
Carrying handle, retrofit set
(if a second carrying handle is desired)

Lfd. Nr.	Kennzeichen	Menge	Benennung/Beschreibung	Sachnummer
No	Unit/Comp.No	Qty	Designation	Stock No.
1		1	Haube, oben 3E, 1/1, T350 Cover, top	1062.6050
2		1	Haube, unten 3E, 1/1, T350 Cover, bottom	396.3773
3		1	Führungsschiene, rechts Guide rail, right	396.4757
4		1	Führungsschiene, links Guide rail, left	396.4763
5		1	Bedienhinweiskarte 1 User guide card 1	1062.5590
6		---	Bedienhinweiskarte 2 User guide card 2	-----
7		---	Bedienhinweiskarte 3 User guide card 3	-----
8		2	Gerätefuß, vorne Instrument foot, front	396.4534
9		2	Aufstellfuß, unten Foot, bottom	396.4540
11		2	Gerätefuß, hinten Instrument foot, rear	396.4586
12		8	Zapfen Pin	396.4634
15		2	Seitenleiste T350 Side strip	396.3073

Lfd. Nr.	Kennzeichen	Menge	Benennung/Beschreibung	Sachnummer
No	Unit/Comp.No	Qty	Designation	Stock No.
16		4	M3 x 6 DIN965 A4	081.9378
17		1	Rückwandfuß, links 3E Rear-panel foot, left	396.4334
18		1	Rückwandfuß, rechts 3E Rear-panel foot, right	396.4128
19		4	Ansatzschr. M4 K.D 7985 Screw	396.4492
21		1	Tragegriff T350 Carrying handle	396.3215
22		2	Griffbuchse Washer	396.3367
23		2	M4 x 10 DIN965 A4	081.9478
24		2	Abdeckung, Griffseite Cover, handle side	396.3350
25		2	Abdeckung, Leerseite Cover, blank side	396.3344
30		1	Frontrahmen 3E 1/1 Front frame	396.2119
31		4	Seitenfuß Side foot	396.4692
32		2	Stapelnutabdeckung Cover for groove	396.4711
33		---	Frontgriff Front grip	-----
34		4	M4 x 8 DIN965	396.1087
35		1	Rückrahmen 3E 1/1 Rear frame	396.2254
36		4	Rahmenschiene T350 Frame rail	396.2360
37		16	M3 x 8 DIN965 A4	081.9384
40		1,09 M	HF-Dichtschnur O-Prof. 2,7 SI RF seal	396.0916
41		3,03 M	WG HF-Dicht. O-Prof. 2,0 SI RF seal	396.1035

Liste mechanischer Teile

List of mechanical parts

Der SMY02 ist in *R&S-Kompaktbauweise 90* aufgebaut.

The SMY02 is designed in accordance with the *R&S design 90*.

Gehäusegröße:
3E, 1/1, T460

Cabinet size:
3E, 1/1, T460

Maße über alles:
435 x 147 x 460 (B x H x T)

Overall dimensions:
435 x 147 x 460 (width x height x depth)

Ergänzungen:
19"-Adapter ZZA
Tragegriff, Nachrüstsatz
(falls ein zweiter Tragegriff gewünscht wird)

Accessories:
19"-Adapter ZZA
Carrying handle, retrofit set
(if a second carrying handle is desired)

Lfd. Nr.	Kennzeichen	Menge	Benennung/Beschreibung	Sachnummer
No	Unit/Comp.No	Qty	Designation	Stock No.
1		1	Haube, oben 3E, 1/1, T460 Cover, top	1062.6044
2		1	Haube, unten 3E, 1/1, T460 Cover, bottom	396.3780
3		1	Führungsschiene, rechts Guide rail, right	396.4757
4		1	Führungsschiene, links Guide rail, left	396.4763
5		1	Bedienhinweiskarte 1 User guide card 1	1062.5590
6		---	Bedienhinweiskarte 2 User guide card 2	-----
7		---	Bedienhinweiskarte 3 User guide card 3	-----
8		2	Gerätefuß, vorne Instrument foot, front	396.4534
9		2	Aufstellfuß, unten Foot, bottom	396.4540
11		2	Gerätefuß, hinten Instrument foot, rear	396.4586
12		8	Zapfen Pin	396.4634
15		2	Seitenleiste T460 Side strip	396.3073

Lfd. Nr.	Kennzeichen	Menge	Benennung/Beschreibung	Sachnummer
No	Unit/Comp.No	Qty	Designation	Stock No.
16		4	M3 x 6 DIN965 A4	081.9378
17		1	Rückwandfuß, links 3E Rear-panel foot, left	396.4334
18		1	Rückwandfuß, rechts 3E Rear-panel foot, right	396.4128
19		4	Ansatzschr. M4 K.D 7985 Screw	396.4492
21		1	Tragegriff T460 Carrying handle	396.3221
22		2	Griffbuchse Washer	396.3367
23		2	M4 x 10 DIN965 A4	081.9478
24		2	Abdeckung, Griffseite Cover, handle side	396.3350
25		2	Abdeckung, Leerseite Cover, blank side	396.3344
30		1	Frontrahmen 3E 1/1 Front frame	396.2119
31		4	Seitenfuß Side foot	396.4692
32		2	Stapelnutabdeckung Cover for groove	396.4711
33		---	Frontgriff Front grip	-----
34		4	M4 x 8 DIN965	396.1087
35		1	Rückrahmen 3E 1/1 Rear frame	396.2254
36		4	Rahmenschiene T460 Frame rail	396.2377
37		16	M3 x 8 DIN965 A4	081.9384
40		1,09 M	HF-Dichtschnur O-Prof. 2,7 SI RF seal	396.0916
41		3,51 M	WG HF-Dicht. O-Prof. 2,0 SI RF seal	396.1035



ROHDE & SCHWARZ

SMY02 SIGNAL GENERATOR

Exploded Mechanical View

Manufacturers Cross Index

MFR. CODE	MANUFACTURER	ADDRESS	CITY, STATE, ZIP CODE
D0894	ROHDE & SCHWARZ	MUEHLDOFSTRASSE 15	8000 MUENCHEN 80, GERMANY

Figure & Index. No.	Stock No.	Qty	Name & Description	CAGE Code	Mfr. Part Number
3-1	1062.6044.00	1 ea	COVER, TOP	D0894	1062.6044.00
3-2	0396.4492.00	4 ea	SCREW, MACHINE: M4 X 12, CHEESE HEAD, X10CRNIMOTI 1810 (DIN7985)	D0894	0396.4492.00
3-3	0396.4334.00	1 ea	REAR-PANEL FOOT, LEFT	D0894	0396.4334.00
3-4	0396.4128.00	1 ea	REAR-PANEL FOOT, RIGHT	D0894	0396.4128.00
3-5	1062.6021.00	1 ea	COVER SET, FRONT AND REAR (VAR 12)	D0894	1062.6021.00
3-6	0396.3780.00	1 ea	COVER, BOTTOM	D0894	0396.3780.00
3-7	0396.4586.00	2 ea	INSTRUMENT FOOT, REAR	D0894	0396.4586.00
3-8	0396.4634.00	8 ea	PIN	D0894	0396.4634.00
3-9	0396.4757.00	1 ea	GUIDE RAIL, RIGHT	D0894	0396.4757.00
3-10	0396.4540.00	2 ea	FOOT, BOTTOM	D0894	0396.4540.00
3-11	0396.4534.00	2 ea	INSTRUMENT FOOT, FRONT	D0894	0396.4534.00
3-12	-----	-----	USER GUIDE CARD 3	D0894	-----
3-13	-----	-----	USER GUIDE CARD 2	D0894	-----
3-14	1062.5590.00	1 ea	USER GUIDE CARD 1	D0894	1062.5590.00
3-15	0396.4763.00	1 ea	GUIDE RAIL, LEFT	D0894	0396.4763.00

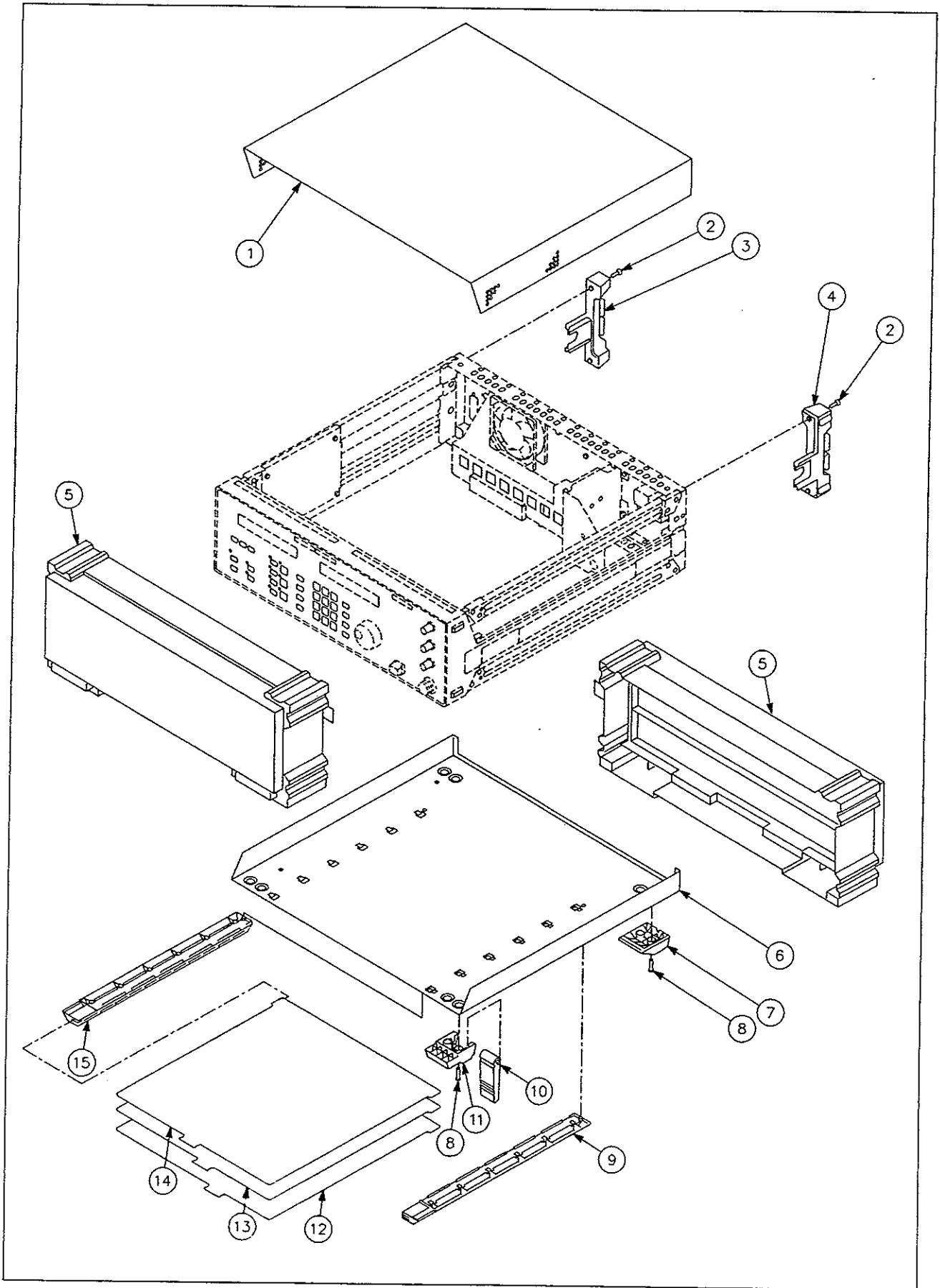

Fig. 6-3 Cabinet and feet

Figure & Index. No.	Stock No.	Qty	Name & Description	CAGE Code	Mfr. Part Number
4-1	0396.8030.00	4 ea	SCREW, MACHINE: M3 X 6, FH, SST (DIN965-A4)	D0894	0396.8030.00
4-2	0396.0916.00	1.09 m	SEALING	D0894	0396.0916.00
4-3	0396.3080.00	2 ea	SIDE STRIP T460 VAR 12	D0894	0396.3080.00
4-4	0396.8046.00	16 ea	SCREW, MACHINE: M3 X 8, FH, SST (DIN965-A4)	D0894	0396.8046.00
4-5	0396.2377.00	4 ea	FRAME GUIDE VAR 12	D0894	0396.2377.00
4-6	0396.1064.00	2 ea	NUT: M4 X RD9, STL	D0894	0396.1064.00
4-7	0079.0525.00	2 ea	NUT: M3, NYLON, WHITE	D0894	0079.0525.00
4-8	0396.2254.00	1 ea	REAR FRAME	D0894	0396.2254.00
4-9	0396.1035.00	3.51 m	SEALING VAR 12	D0894	0396.1035.00
4-10	0081.9084.00	11 ea	SCREW, MACHINE: M3 X 10, CHEESE HEAD, SST (DIN7985-A4)	D0894	0081.9084.00
4-11	0396.3221.00	1 ea	CARRYING HANDLE	D0894	0396.3221.00
4-12	0396.3350.00	2 ea	COVER, HANDLE SIDE	D0894	0396.3350.00
4-13	0081.9478.00	2 ea	SCREW, MACHINE: M4 X 10, FH, SST (DIN965-A4)	D0894	0081.9478.00
4-14	0396.3367.00	2 ea	WASHER, SHOULDER: 24 OD, 5 THK, FLAT SIDE, X10CRN189 (DIN671)	D0894	0396.3367.00
4-15	0081.9084.00	3 ea	SCREW, MACHINE: M3 X 10, CHEESE HEAD, SST (DIN7985-A4)	D0894	0081.9084.00
4-16	0062.1130.00	3 ea	FEED-THROUGH, RD4 X RD9, 5 X 5, 6	D0894	0062.1130.00
4-17	0082.4686.00	3 ea	WASHER, FLAT: 4.3 ID X 9 OD, 0.8 THK, SST (DIN125-A4)	D0894	0082.4686.00
4-18	0031.2805.00	3 ea	TUBING RIVET: B4 X 6-MS-E1P, RUBBER, BLACK (DIN7340)	D0894	0031.2805.00
4-19	1062.5860.00	1 ea	ATTENUATOR HOLDER	D0894	1062.5860.00
4-20	0396.4692.00	4 ea	SIDE FOOT	D0894	0396.4692.00
4-21	0396.2119.00	1 ea	FRONT FRAME	D0894	0396.2119.00
4-22	0081.9378.00	2 ea	SCREW, MACHINE: M3 X 6, FH, SST (DIN965-A4)	D0894	0081.9378.00
4-23	0032.5237.00	1 ea	SEALING SPRING	D0894	0032.5237.00
4-24	See EPL	1 ea	ATTENUATOR SMG/SMH VAR 12 (A6)	D0894	See EPL
4-25	1062.5990.00	1 ea	LP HOLDER VAR 12	D0894	1062.5990.00
4-26	1062.5983.00	1 ea	LP HOLDER	D0894	1062.5983.00
4-27	0396.4711.00	2 ea	COVER FOR GROOVE	D0894	0396.4711.00
4-28	0396.3344.00	2 ea	COVER, BLANK SIDE	D0894	0396.3344.00

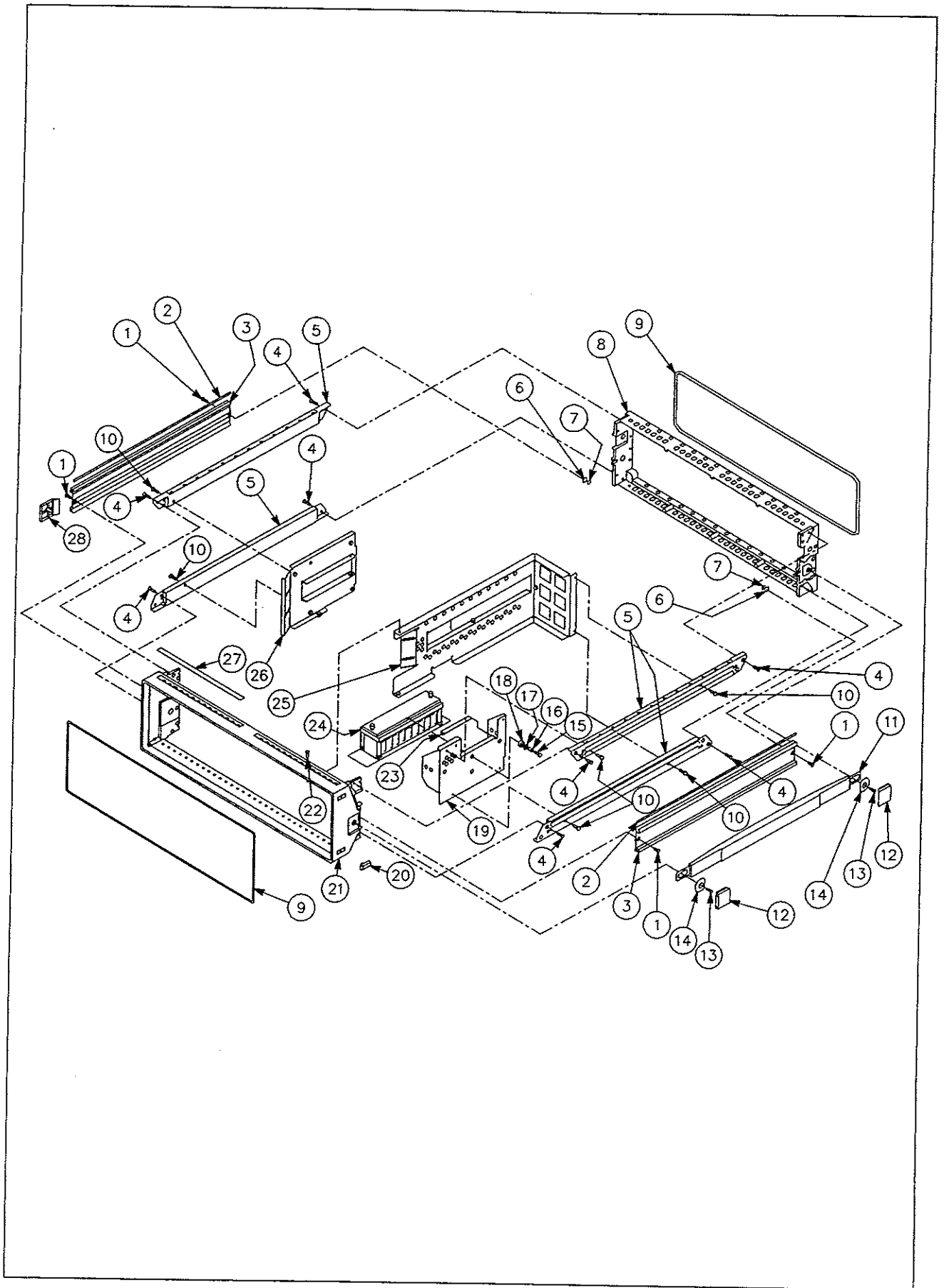

Figure 6-4 Chassis

Figure & Index. No.	Stock No.	Qty	Name & Description	CAGE Code	Mfr. Part Number
5-1	1062.5602.00	1 ea	COVER,VARNISH+INSCRIPTION	D0894	1062.5602.00
5-2	1062.5631.00	1 ea	MOUNTING PLATE	D0894	1062.5631.00
5-3	See EPL	1 ea	KEYBOARD/DISPLAY (A1)	D0894	See EPL
5-4	0001.9499.00	0.075 m	PLASTIC CHANNEL	D0894	0001.9499.00
5-5	1062.5648.00	1 ea	SHIELDING	D0894	1062.5648.00
5-6	See EPL	1 ea	MOTHERBOARD (A3)	D0894	See EPL
5-7	0088.3146.00	4 ea	WASHER, FLAT: 2.7 ID X 6.5 OD, 0.5 THK, NYLON	D0894	0088.3146.00
5-8	0071.5705.00	4 ea	SCREW, MACHINE: M2.5 X 8, CHEESE HEAD, SST (DIN7985-A2)	D0894	0071.5705.00
5-9	See EPL	1 ea	CABLE, ASSY: 34, RIBBON, APPROX 10 CM (W3)	D0894	See EPL
5-10	1062.5890.00	1 ea	SWITCH ROD VAR 12	D0894	1062.5890.00
5-11	0099.1410.00	1 ea	GROMMET, BLACK, RUBBER	D0894	0099.1410.00
5-12	0081.9378.00	8 ea	SCREW, MACHINE: M3 X 6, FH, SST (DIN965-A4)	D0894	0081.9378.00
5-13	See EPL	1 ea	CABLE, ASSY: 26, RIBBON, APPROX 47 CM (W21)	D0894	See EPL
5-14	See EPL	1 ea	CABLE, ASSY: 16, RIBBON, APPROX 33 CM (W77)	D0894	See EPL
5-15	See EPL	1 ea	CABLE, ASSY: 10, RIBBON, APPROX 20 CM (W20)	D0894	See EPL
5-16	0099.7825.00	1 ea	FLAT CABLE HOLDER	D0894	0099.7825.00
5-17	0099.9186.00	3 ea	BNC-CONNECTOR UG 625CIU	D0894	0099.9186.00
5-18	0035.0813.00	3 ea	SOLDERING LUG, 18 x 10	D0894	0035.0813.00
5-19	See EPL	1 ea	CABLE, ASSY: SEMIRIGID COAX, APPROX 30 CM (W1)	D0894	See EPL
5-20	0099.4161.00	3 ea	INSULATING RING FOR BNC-S	D0894	0099.4161.00
5-21	0088.0147.00	6 ea	SCREW, MACHINE: M2.5 X 16, FH, SST (DIN965-A4)	D0894	0088.0147.00
5-22	0396.0897.00	1 ea	SPOUT	D0894	0396.0897.00
5-23	0078.3795.00	1 ea	SCREW, MACHINE: M1.6 X 3, FH, SST (DIN965-A4)	D0894	0078.3795.00
5-24	0078.1192.00	1 ea	KNOB: W/SET SCREW, 5/64 ALLEN	D0894	0078.1192.00
5-25	1062.6180.00	1 ea	LABEL, PART NUMBER VAR 12	D0894	1062.6180.00
5-26	1062.5948.00	1 ea	LABEL, MODEL VAR 12	D0894	1062.5948.00
5-27	1062.6167.00	1 ea	LABEL, FREQUENCY RANGE VAR 12	D0894	1062.6167.00
5-28	0396.5518.00	4 ea	WASHER, COUNTERSUNK: 7.2 OD X 1.8 THK, RD 7.5 CUZN40PB2	D0894	0396.5518.00
5-29	0081.9384.00	4 ea	SCREW, MACHINE: M3 X 8, FH, SST (DIN965-A4)	D0894	0081.9384.00

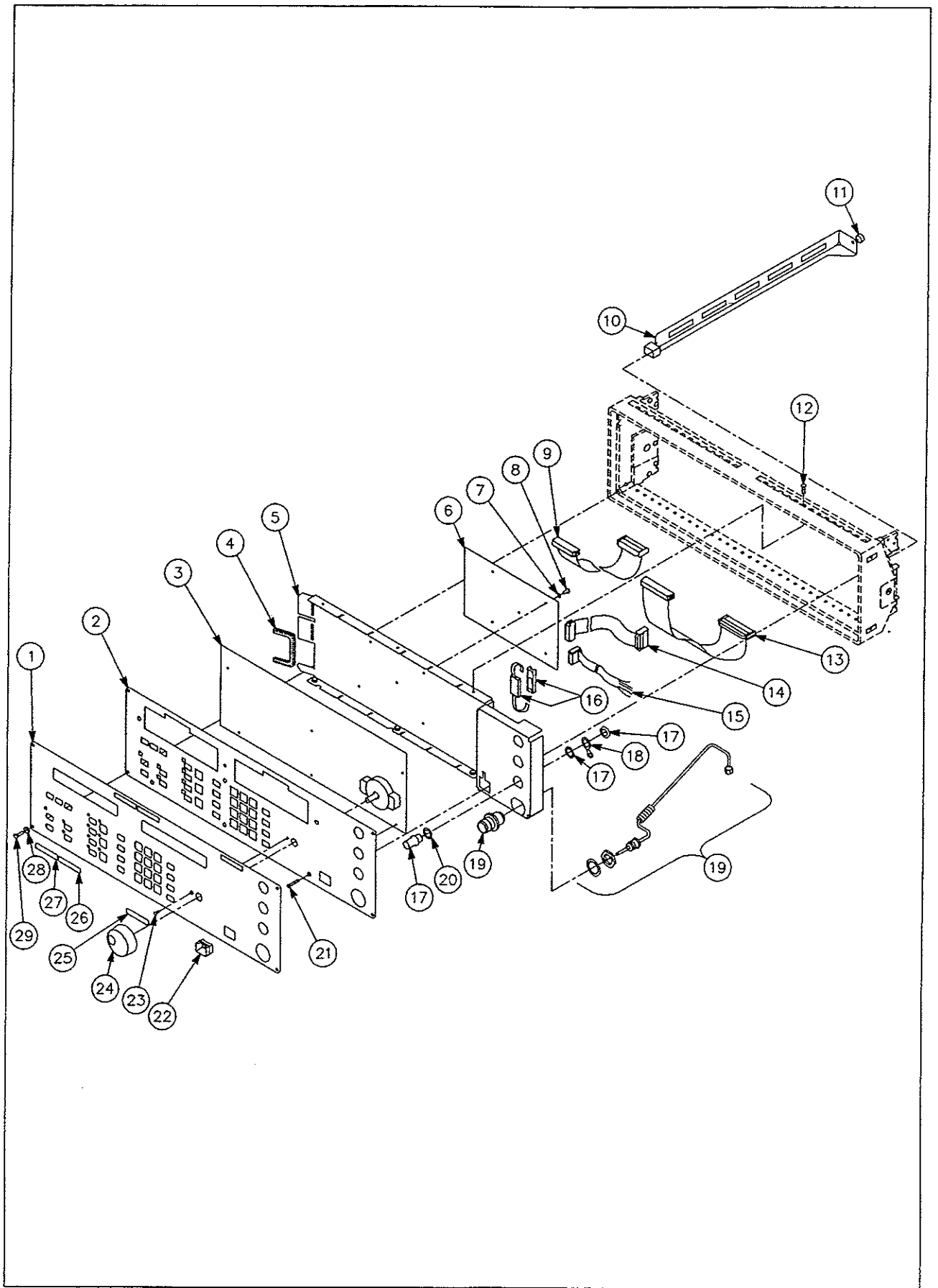

Fig. 6-5 Front panel assembly

Figure & Index No.	Stock No.	Qty	Name & Description	CAGE Code	Mfr. Part Number
6-1	0088.7693.00	62 ea	SCREW, MACHINE: M2 X 5, SST (A2)	D0894	0088.7693.00
6-2	1062.7057.00	1 ea	TOP COVER, OUTPUT UNIT MODULE	D0894	1062.7057.00
6-3	0071.6853.00	6 ea	SCREW, MACHINE: M3 X 8, CHEESE HEAD, SST (DIN7895-A2, DIN6902-A2, DIN6904-A2)	D0894	0071.6853.00
6-4	See EPL	1 ea	OUTPUT UNIT 2.08 GHZ (A5)	D0894	See EPL
6-5	1062.7065.00	1 ea	BOTTOM COVER, OUTPUT UNIT MODULE	D0894	1062.7065.00
6-6	See EPL	1 ea	CABLE, ASSY: SEMIRIGID, COAX, APPROX 12 CM (W26)	D0894	See EPL
6-7	1062.6473.00	1 ea	TOP COVER, SYNTHESIZER MODULE	D0894	1062.6473.00
6-8	See EPL	1 ea	SYNTHESIZER (A4)	D0894	See EPL
6-9	1062.6480.00	1 ea	BOTTOM COVER, SYNTHESIZER MODULE	D0894	1062.6480.00
6-10	1062.6373.00	1 ea	TOP COVER, PROCESSOR MODULE	D0894	1062.6373.00
6-11	See EPL	1 ea	PROCESSOR (A2)	D0894	See EPL
6-12	1062.6380.00	1 ea	BOTTOM COVER, PROCESSOR MODULE	D0894	1062.6380.00
6-13	0071.7572.00	8 ea	SCREW, MACHINE: M2.5 X 6, FH, SST	D0894	0071.7572.00
6-14	0071.5757.00	47 ea	SCREW, MACHINE: M2.5 X 10.4, FH, SST	D0894	0071.5757.00
6-15	See EPL	1 ea	CABLE, ASSY: FLEXIBLE, COAX, APPROX 4 CM (W25)	D0894	See EPL
6-16	See EPL	1 ea	CABLE, ASSY: FLEXIBLE, COAX, APPROX 4 CM (W24)	D0894	See EPL

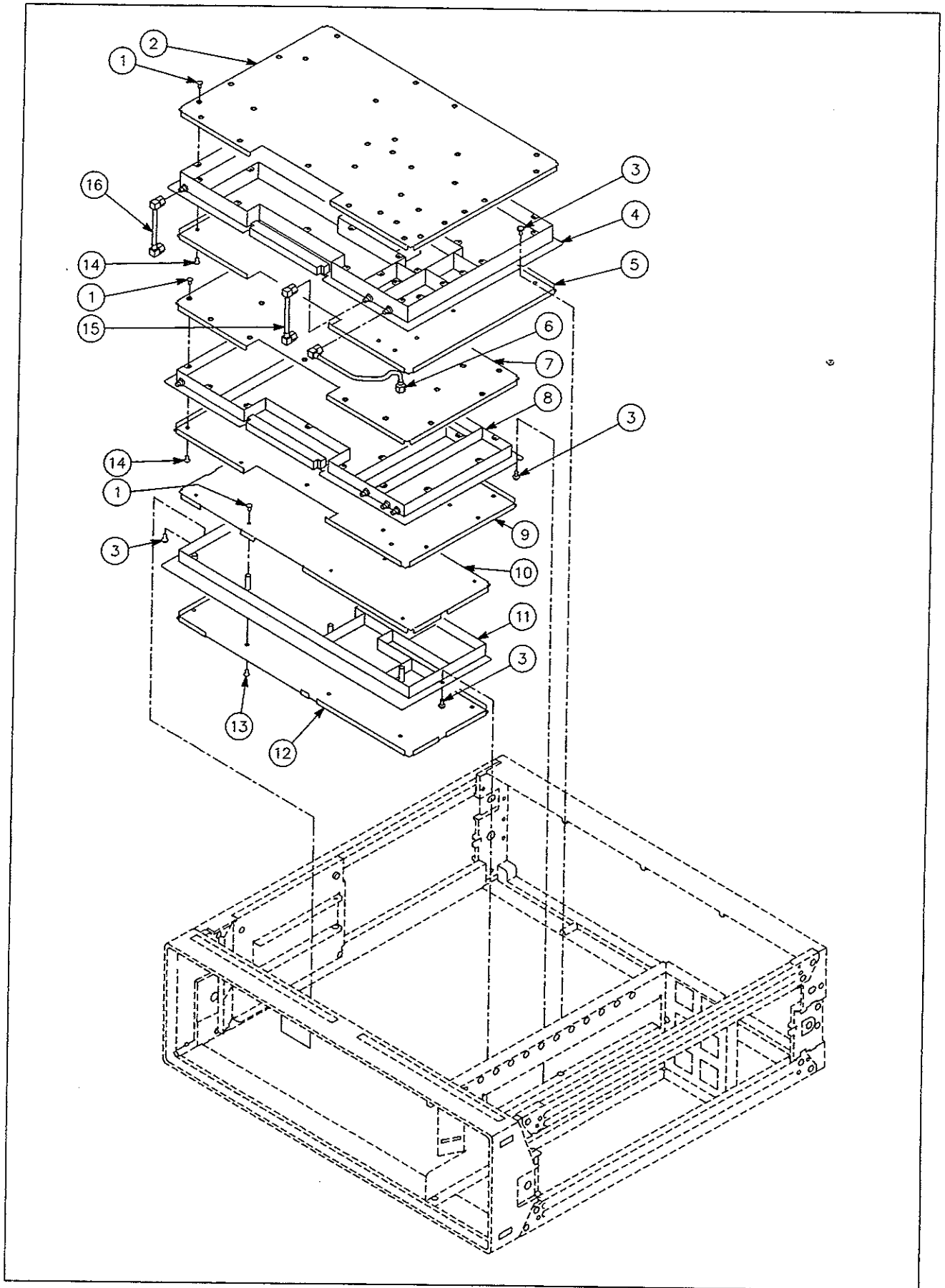

Fig. 6-6 Circuit boards

Figure & Index No.	Stock No.	Qty	Name & Description	CAGE Code	Mfr. Part Number
7-1	1062.5831.00	1 ea	POWER SUPPLY HOLDER	D0894	1062.5831.00
7-2	0554.5528.00	1 ea	BOLT, HEX HEAD: M6 X 12 (DIN933)	D0894	0554.5528.00
7-3	0031.5210.00	1 ea	WASHER, FLAT: 6.1 ID X 18 OD, 1.6 THK, SST (DIN9021-A4)	D0894	0031.5210.00
7-4	0005.2524.00	1 ea	WASHER, SPRING: 6.1 ID X 11.8 OD, 2.2 THK, SST (DIN128-A2)	D0894	0005.2524.00
7-5	See EPL	1 ea	FAN UNIT (E1)	D0894	See EPL
7-6	1062.5725.00	1 ea	REAR PANEL	D0894	1062.5725.00
7-7	0071.6853.00	2 ea	SCREW, MACHINE: M3 X 8, CHEESE HEAD, SST (DIN7895-A2, DIN6902-A2, DIN6904-A2)	D0894	0071.6853.00
7-8	0005.0296.00	4 ea	WASHER, SPRING: 3.2 ID X 6.0 OD, 0.4 THK, SST (DIN137-A2)	D0894	0005.0296.00
7-9	0082.4670.00	4 ea	WASHER, FLAT: 3.2 ID X 7.0 OD, 0.5 THK, SST (DIN125-A4)	D0894	0082.4670.00
7-10	0081.9084.00	4 ea	SCREW, MACHINE: M3 X 10, CHEESE HEAD, SST (DIN7985-A4)	D0894	0081.9084.00
7-11	0071.6853.00	4 ea	SCREW, MACHINE: M3 X 8, CHEESE HEAD, SST (DIN7895-A2, DIN6902-A2, DIN6904-A2)	D0894	0071.6853.00
7-12	1062.5954.00	1 ea	SERIAL, NUMBER	D0894	1062.5954.00
7-13	1062.5754.00	1 ea	COOLING PROFILE	D0894	1062.5754.00
7-14	0005.0296.00	6 ea	WASHER, SPRING: 3.2 ID X 6.0 OD, 0.4 THK, SST (DIN7895-A2)	D0894	0005.0296.00
7-15	0082.4670.00	6 ea	WASHER, FLAT: 3.2 ID X 7.0 OD, 0.5 THK, SST (DIN125-A4)	D0894	0082.4670.00
7-16	0081.9084.00	6 ea	SCREW, MACHINE: M3 X 10, CHEESE HEAD, SST (DIN7985-A4)	D0894	0081.9084.00
7-17	0071.6860.00	1 ea	SCREW, MACHINE: M4 X 8, CHEESE HEAD, SST (DIN7895-A2)	D0894	0071.6860.00
7-18	0081.9384.00	2 ea	SCREW, MACHINE: M3 X 8, FH, SST (DIN965-A4)	D0894	0081.9384.00
7-19	See EPL	2 ea	FUSE (F1/F2)	D0894	See EPL
7-20	0006.0919.00	1 ea	FILTER W/VOLTAGE SELECTION, W/2 FUSE CARTRIDGE HOLDERS	D0894	0006.0919.00
7-21	0071.6853.00	4 ea	SCREW, MACHINE: M3 X 8, CHEESE HEAD, SST (DIN7895-A2, DIN6902-A2, DIN6904-A2)	D0894	0071.6853.00
7-22	0016.2837.00	1 ea	WASHER, LOCKING: 4.3 ID X 8.0 OD, 1 THK, SST (DIN6797-A2)	D0894	0016.2837.00
7-23	0543.6705.00	1 ea	CONNECTOR	D0894	0543.6705.00
7-24	0085.0330.00	1 ea	NUT, SQUARE: M4 X 9, 2 THK	D0894	0085.0330.00
7-25	1062.5790.00	1 ea	WIRE SET	D0894	1062.5790.00
7-26	See EPL	1 ea	TRANSFORMER (T1)	D0894	See EPL
7-27	0071.6830.00	2 ea	SCREW, MACHINE: M2.5 X 5, CHEESE HEAD, SST (DIN7985-A2)	D0894	0071.6830.00
7-28	0007.7130.00	1 ea	COVER, POWER SWITCH	D0894	0007.7130.00
7-29	0007.5143.00	1 ea	POWER SWITCH	D0894	0007.5143.00
7-30	1062.5848.00	1 ea	BRACKET, L-SHAPED	D0894	1062.5848.00
7-31	0081.9390.00	4 ea	SCREW, MACHINE: M3 X 10, FH, SST (DIN965-A4)	D0894	0081.9390.00
7-32	0396.3167.00	4 ea	NUT FOR REAR FRAME, TAPPED FOR M3 THREAD	D0894	0396.3167.00
7-33	0528.8500.00	3 ea	STOPPER	D0894	0528.8500.00
7-34	See EPL	1 ea	CABLE, IEC/IEEE CONNECTOR, WITH ATTACHING HARDWARE (W2)	D0894	See EPL

Figure & Index. No.	Stock No.	Qty	Name & Description	CAGE Code	Mfr. Part Number
7-35	0043.5827.00	1 ea	SEALING RUBBER	D0894	0043.5827.00
7-36	1062.5819.00	1 ea	ANGLE FOR CONNECTOR	D0894	1062.5819.00
7-37	0099.9186.00	2 ea	BNC-CONNECTOR UG 625CIU	D0894	0099.9186.00
7-38	0035.0813.00	1 ea	SOLDERING LUG, 18 X 10	D0894	0035.0813.00
7-39	See EPL	1 ea	CABLE, ASSY: FLEXIBLE, COAX, APPROX 53 CM (W27)	D0894	See EPL
7-40	See EPL	1 ea	CABLE, ASSY: 10, RIBBON, APPROX 47 CM (W4)	D0894	See EPL
7-41	0099.9186.00	1 ea	BNC-CONNECTOR UG 625CIU	D0894	0099.9186.00
7-42	0099.7825.00	1 ea	FLAT CABLE HOLDER	D0894	0099.7825.00
7-43	0071.6853.00	5 ea	SCREW, MACHINE: M3 X 8, CHEESE HEAD, SST (DIN7895-A2, DIN6902-A2, DIN6904-A2)	D0894	0071.6853.00
7-44	See EPL	1 ea	POWER SUPPLY (A7)	D0894	See EPL
4-45	0088.0060.00	3 ea	SCREW, MACHINE: M2.5 X 12, CHEESE HEAD (DIN7895-A4)	D0894	0088.0060.00
7-46	0082.4663.00	3 ea	WASHER, FLAT: 2.7 ID X 6.5 OD, 0.5 THK, SST (DIN125-A4)	D0894	0082.4663.00
7-47	0005.0280.00	3 ea	WASHER, SPRING: 2.8 ID X 5.5 OD, 0.3 THK, SST (DIN137-A2)	D0894	0005.0280.00
7-48	1062.5719.00	1 ea	SHIELDING	D0894	1062.5719.00
7-49	0088.6680.00	4 ea	NUT, M3 X 6, PRESSFIT	D0894	0088.6680.00

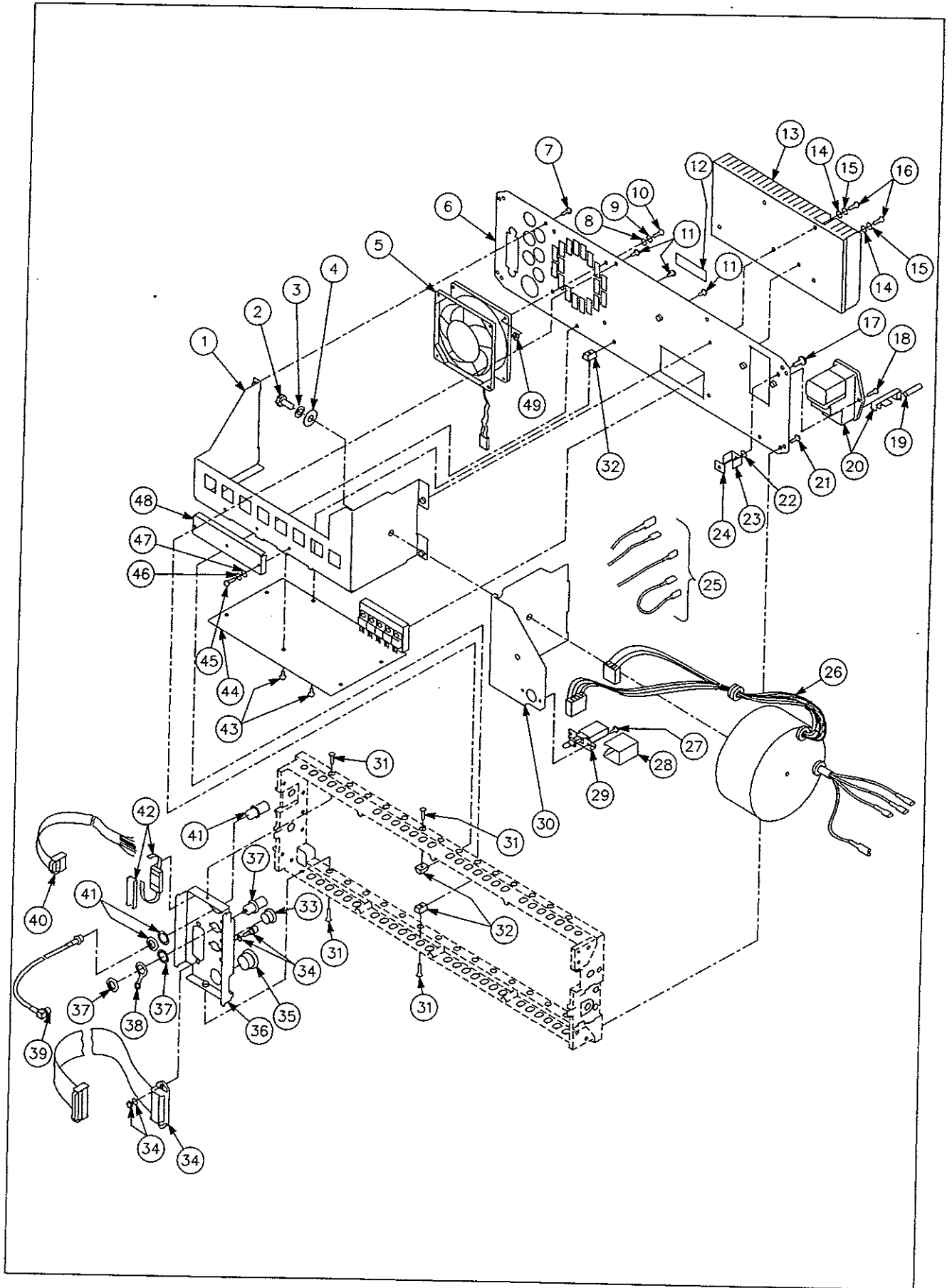

Fig. 6-7 Rear panel assembly

Figure & Index No.	Stock No.	Qty	Name & Description	CAGE Code	Mfr. Part Number
Standard Accessories					
8-1	0086.4400.00	1 ea	POWER CORD	D0894	0086.4400.00
8-2	0200.7575.00	2 ea	FUSE: T2,5HIEC127-2/V	D0894	0200.7575.00
	1062.5583.18		MANUAL, TECH: OPERATING	D0894	1062.5583.18
Optional Accessories					
	1062.5583.28		MANUAL, TECH: SERVICE VOLUMES 1 AND 2	D0894	1062.5583.28
	1062.7805.02		SMY-C2, SERVICE KIT FOR SMY	D0894	1062.7805.02

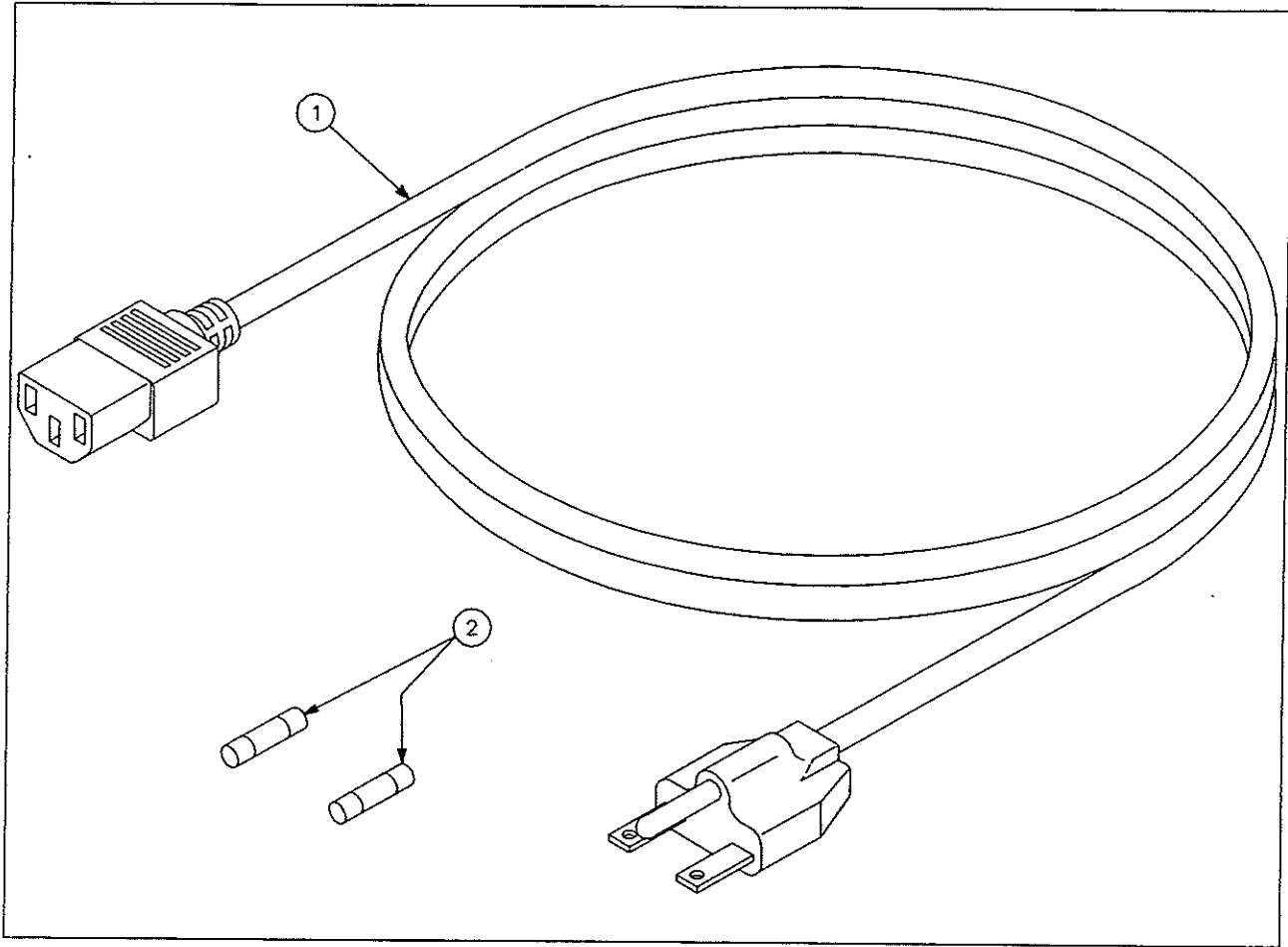

Fig. 6-8 Accessories



ROHDE & SCHWARZ

**Schlüsselliste
für Bauteile-Sachnummern
Code list
for component stock Nos.
Liste
des références des composants**



R&S-Schlüsselliste

R&S key list

Liste des symboles de référence R&S

Die R&S-Schaltteillisten nennen in der Spalte "Benennung/Beschreibung" die technischen Daten der Bauelemente in Kurzform. Die Art des Bauelements (z.B. Schicht-, Draht-Widerstand usw.) beschreiben die 2 Kennbuchstaben vor der "Benennung" (evtl. auch vor der "Sachnummer"), die nachfolgend erklärt werden. In Ersatzteil-Bestellungen an R&S ist stets die Angabe der vollständigen Sachnummer erforderlich.

The R&S Parts Lists give the technical data of the components in short form in the column "Benennung/Beschreibung" (designation). The type of component (e.g. depos.-carbon resistor, wire-wound resistor etc.) is indicated by 2 identification letters before the designation, possibly also before the "Sachnummer" (order number), which are explained below. When ordering spare parts from R&S, the complete order number must always be specified.

La colonne «Désignation/description» des listes de pièces de R&S indique les caractéristiques des éléments sous forme abrégée. Le type d'élément (p.ex. résistance à couche, résistance bobinée etc. ...) est décrit par les deux lettres précédant la désignation (et éventuellement le numéro de référence), dont voici l'explication. Prière d'indiquer le numéro de référence («Sachnummer») complet dans toute commande de pièces de rechange.

Teilefamilie	Art des Bauelementes	Parts family	Type of component	Familie	Type d'élément
A	Aktive Bauelemente, Halbleiter	A	Active components, semiconductors	A	Composants actifs, semiconducteurs
AD	Universaldiode, z.B. Gleichrichter, Sperrdiode	AD	General-purpose diode, e.g. rectifier, high-resistance diode	AD	Diode d'usage général, p.ex. redresseur, diode à haute résistance
AE	Spezialdiode, z.B. Tunnel-, Kapazitäts-, Zener-Diode	AE	Diode (special), e.g. tunnel diode, varactor, Zener diode	AE	Diode spéciale, p.ex. diode tunnel, varactor, diode Zener
AF	Fotohalbleiter, z.B. Foto-Diode, -Transistor, -Widerstand, Leucht-diode	AF	Photo-semiconductor, e.g. resistor, diode, transistor, LED	AF	Semiconducteur photoélectrique, p.ex. diode, transistor, résistance photoél., DEL
AG	Leistungs-Gleichrichter, z.B. Thyristor, Triac, Selengleichrichter	AG	Power rectifier, e.g. thyristor, triac, selenium rectifier	AG	Redresseur de puissance, p.ex. thyristor, triac, redresseur, au sélénium
AK	Kleinsignal-Transistor	AK	Small-signal transistor	AK	Transistor faible puissance
AL	Leistungs-Transistor	AL	High-power transistor	AL	Transistor grande puissance
AM	Spezial-Transistor, z.B. FET, MOSFET	AM	Transistor (special), e.g. FET, MOS-FET	AM	Transistor spécial, p.ex. TEC, MOSTEC
AP	Peltier-, Hall-Element	AP	Peltier element, Hall element	AP	Element Peltier, élément Hall
AR	Röhre für Empfänger, Verstärker, Gleichrichter	AR	Valve for receiver, amplifier, rectifier	AR	Tube pour récepteur, amplificateur, redresseur
AS	Spezialröhre, z.B. Senderöhre, EW-Widerstand, Stabilisator	AS	Valve (special), e.g. for transmitter, baretter, ballast valve	AS	Tube (spécial), p.ex. pour émetteur, résistance fer-hydrogène, ballast
AT	Katodenstrahlröhre, z.B. Bildröhre, Ziffern-Anzeigeröhre	AT	Cathode ray tube, e.g. picture tube, digital indicator tube	AT	Tube à rayon cathodique, p.ex. tube à image, tube à affichage numérique
AZ	Zubehör für Halbleiter u. Röhren	AZ	Accessories for semiconductors and valves	AZ	Accessoires pour semiconducteurs et tubes
B	Bausteine	B	PC boards, chips	B	Cartes imprimées, puces
BC	Integr. Schaltkreis (Microcomp.)	BC	Integrated circuit (interface, A/D)	BC	Circuit intégré (microprocesseur)
BD	R&S-Dünnschicht- und Dickschicht-schaltung	BD	R&S thinfilm or thickfilm circuit	BD	Circuit R&S à couche mince ou épaisse
BG	R&S-spezifische Gate-Arrays	BG	R&S gate arrays	BG	Circuits intégrés prédiffusés R&S
BJ	Integrierter Schaltkreis (Interface, A/D-Wandler)	BJ	Integrated circuit (interface, A/D converter)	BJ	Circuit intégré (interface, convertisseur A/N)
BL	Log. Schaltkreis z.B. DTL, TTL, HTL, ECL, C-MOS	BL	Logic circuit, e.g. DTL, TTL, HTL, ECL, C-MOS	BL	Circuit logique, p.ex. DTL, TTL, HTL, ECL, C-MOS
BM	Hybridbaustein, z.B. Mischer, Tuner, Modulator	BM	Hybrid chip, e.g. mixer, tuner, modulator	BM	Puce hybride, p.ex. mélangeur, tuner, modulateur
BO	Analogschaltkreis, z.B. Operationsverstärker	BO	Analog circuit, e.g. operational amplifier	BO	Circuit analogique, p.ex. amplificateur opérationnel
BP	Optoelektronischer Baustein, z.B. Anzeigeeinheit, Koppler	BP	Optoelectronic component, e.g. display, coupler	BP	Composant optoélectronique, p.ex. afficheur, coupleur
BS	Schalt- und Steuerbaustein, elektronischer Sensor	BS	Switching and control modul, electronic sensor	BS	Modul de commutation et de commande, sonde électronique
BV	Stromversorgung, Übersp.-Schutz	BV	Power pack, protective circuit	BV	Alimentation, protection surcharge
BZ	Zubehör	BZ	Accessories	BZ	Accessoires

Teile- familie	Art des Bauelementes	Parts family	Type of component	Familie	Type d'élément
C	Kondensatoren	C	Capacitors	C	Condensateurs
CB	Bypass-, Durchf.-Kondensator	CB	Bypass capacitor, feed-through capacitor	CB	Condensateur bypass, condensateur de traversée
CC	Keramischer Kondensator	CC	Ceramic capacitor	CC	Condensateur céramique
CD	Drehkondensator	CD	Variable capacitor	CD	Condensateur variable
CE	Elektrolytkondensator	CE	Electrolytic capacitor	CE	Condensateur électrolytique
CG	Glimmerkondensator	CG	Mica capacitor	CG	Condensateur au mica
CH	Sperrschichtkondensator	CH	Semiconductor capacitor	CH	Condensateur semiconducteur
CK	Kunstfolienkondensator	CK	Synthetic-foil capacitor	CK	Condensateur à feuille synthétique
CL	Ker. Hochsp.-Kondensator	CL	HV capacitor (ceramic)	CL	Condensateur HT céramique,
CM	Metallpapier-Kondensator	CM	MP capacitor	CM	Condensateur à papier métallisé
CN	Kondensatornetzwerk	CN	Capacitor network	CN	Réseau capacitif
CP	Papierkondensator	CP	Paper capacitor	CP	Condensateur au papier
CS	Störschutzkondensator	CS	Interference-suppression capacitor	CS	Condensateur anti-parasite
CT	Trimmkondensator	CT	Trimmer capacitor	CT	Condensateur ajustable
CV	Vakuum-Kondensator	CV	Vacuum capacitor	CV	Condensateur à vide
D	Drähte, Leitungen	D	Wires, lines	D	Fils, lignes
DD	Schalt- und Wickeldraht	DD	Hook-up or winding wire	DD	Fil de câblage, fil de bobinage
DF	Flachleitung, Litze	DF	Flat multiple line, stranded wire	DF	Ligne plate, ligne torsadée
DG	Abgeschirmte Leitung	DG	Shielded line	DG	Ligne blindé
DH	Koaxialkabel	DH	Coaxial line	DH	Ligne coaxiale
DJ	Isolierschläuche, Schrumpfschläuche, Wellrohre, Schutzschläuche	DJ	Insulating sheaths, shrink-on sleeves, corrugated tubes, protective tubes	DJ	Gaines isolantes, gaines thermorétractables tubes ondulés, gaines protectrices
DL	HF-Litzen	DL	RF stranded wires	DL	Lignes torsadées RF
DM	Schalllitzen (mehrdrähtige Leiter)	DM	Multi-conductor wires	DM	Lignes torsadées (multiconducteurs)
DN	Antenne	DN	Antenna	DN	Antenne
DO	Lichtleiter (optisch)	DO	Optical waveguides	DO	Guides d'onde optiques
DP	Leiterplatten (unbestückt)	DP	Printed circuit boards (bare)	DP	Cartes imprimées (non équipées)
DQ	Multilayer (unbestückt)	DQ	Multilayer boards (bare)	DQ	Cartes multicouche (non équipées)
DS	Anschlußkabel (mehradrig)	DS	Connecting cable, multicore	DS	Câble de connexion (multiconducteur)
DU	Substratplatten für Dickschichtschaltungen	DU	Substrate boards for thickfilm circuits	DU	Cartes à substrat pour circuits à couche épaisse
DW	Festmantelkabel	DW	Rigid cables	DW	Câbles rigides
E	Elektrische Teile	E	Electric parts	E	Organes électriques
EB	Blei-, NC-Akku, Batterie	EB	Lead or alkaline accumulator, battery	EB	Accumulateur Pb/NC, batterie
ED	Gedruckte Schaltung (bestückte Leiterplatte), nicht steckbar	ED	Printed circuits (assembled), non-pluggable	ED	Circuits imprimés (équipés) non enfichables
EE	Gedruckte Schaltung (bestückte Leiterplatte), steckbar	EE	Printed circuits (assembled), pluggable	EE	Circuits imprimés (équipés) enfichables
EF	Glühlampe, Leuchte	EF	Incandescent lamp, pilot lamp	EF	Lampe à incandescence, voyant
EG	Glimmlampe, Entladungslampe	EG	Glow lamp, discharge lamp	EG	Lampe à luminescence lampe à décharge
EK	Kontakt-Streifen, -Feder	EK	Contact clip, contact spring	EK	Lampe de contact, ressort de contact
EL	Lautsprecher, Kopfhörer, Mikrofon	EL	Loudspeaker, headphones, microphone	EL	Haut-parleur, casque, microphone
EM	Motor, Hubmagnet, Drehfeldsystem	EM	Motor, lifting magnet, synchro system	EM	Moteur, électro-aimant de levage, système synchro
EO	Oszillator, z.B. Quarzoszillator	EO	Oscillator, e.g. crystal oscillator	EO	Oscillateur p.ex. oscillateur à quartz
EP	Tief-, Band-, Hochpaß, Bandsperre, Diskriminator	EP	Lowpass, bandpass, highpass filter, band-stop filter, discriminator	EP	Filtre passe-bas, passe-bande, passe-haut, suppression de bande, discriminateur
EQ	Schwing-, Filter-Quarz	EQ	Oscillator or filter crystal	EQ	Quartz oscillateur, quartz de filtre
ER	Resonator, piezoelekt./magnetostruktiv	ER	Resonator, piezoelectric/magnetostrictive	ER	Résonateur piézo-électrique/magneto-strictif
ES	Passive SHF-Bauteile	ES	Passive SHF-components	ES	Composant SHF passif
ET	Thermostat	ET	Thermostat	ET	Thermostat
EV	Lüfter, Gebläse	EV	Ventilator, blower	EV	Ventilateur, soufflerie



Teile- familie	Art des Bauelementes	Parts family	Type of component	Familie	Type d'élément
F	Fassungen, Steckverbindungen	F	Sockets, connectors	F	Douilles, connecteurs
FG	Koax-Umrüstsatz	FG	Coaxial screw-in assembly	FG	Ensemble vissable coaxial
FH	Koax-Übergang auf Fremdsystem	FH	Coaxial adapter	FH	Adaptateur coaxial
FJ	BNC-Systemteil	FJ	BNC screw-in assembly	FJ	Ensemble vissable BNC
FK	Koaxial-UHF-Systemteil	FK	Coaxial UHF screw-in assembly	FK	Ensemble vissable coaxial UHF
FM	Mehrfachstecker, Buchsenleiste	FM	Multipoint connector	FM	Connecteur multiple
FN	Netz-Steckverbindung	FN	AC-supply connector	FN	Connecteur secteur
FO	Runde Mehrfach-Steckverbindung	FO	Round multipoint connector	FO	Connecteur multipoles rond
FP	Druckschalt-Steckverbindung	FP	Multipoint connector for PC boards	FP	Connecteur multipoles pour cartes imprimées
FR	Fassung für Lampe, Sicherung, usw.	FR	Socket for lamp, fuse, etc.	FR	Douille pour lampe, fusible etc. . . .
FT	Schwachstrom-Steckverbindung	FT	LV plug and socket	FT	Connecteur pour faible courant
FU	Hochspannungs-Steckverbindung	FU	HV plug and socket	FU	Connecteur pour haute tension
FV	Verbinder (z.B. AMP)	FV	Push-on connector	FV	Connecteur à enfichage
FZ	Zubehör für koax. Bauelemente	FZ	Accessories for coax. components	FZ	Accessoires pour composants coax.
H	Software	H	Software	H	Logiciel
HP	Software-Komponenten und Software-Module	HP	Rights to software components and software modules	HP	Droits d'utilisation de composants et modules logiciel
HS	Auf Informationsträger geladene Software	HS	Software data media	HS	Logiciel sur support d'information
J	Meßinstrumente	J	Indicators	J	Indicateurs
JD	Drehspul-Anzeigeeinstrument	JD	Moving-coil meter	JD	Galvanomètre à cadre mobile
JE	Dreheisen-Anzeigeeinstrument	JE	Moving-iron meter	JE	Galvanomètre à fer mobile
JF	Frequenzmesser	JF	Frequency meter	JF	Fréquence-mètre
JG	Drehspulinstrument mit Gleichrichter	JG	Moving-coil meter with rectifier	JG	Galvanomètre à cadre mobile avec redresseur
JH	Betriebsstundenzähler	JH	Operating-hours counter	JH	Compteur d'heures de fonctionnement
JJ	Impulszähler	JJ	Pulse counter	JJ	Compteur d'impulsions
JK	Kleinst-Instrument, z.B. Abstimmanzeiger	JK	Mini-instrument, e.g. tuning indicator	JK	Petit indicateur, p.ex. indicateur d'accord
JM	Mechanisches Zählwerk	JM	Mechanical counter	JM	Compteur mécanique
JP	Projektions-Instrument (Leuchtziffer)	JP	Digital display	JP	Afficheur numérique
JQ	Quotientenmesser (Kreuzspulinstrum.)	JQ	Ratiometer (cross coul)	JQ	Quotientmètre (à cadres croisés)
JU	Uhrwerk	JU	Clockwork	JU	Mouvement d'horlogerie
JW	Elektrodyn. Anzeigeeinstrument	JW	Electrodynamic meter	JW	Instrument électrodynamique
L	Induktivitäten, Magnetik	L	Inductors, magnetic components	L	Composants inductifs et magnétiques
LB	Blech- und Schnittbandkern mit Zubehör	LB	Laminated and C-cores with accessories	LB	Noyaux feuilletés et noyaux de type C, avec accessoires
LC	Keramische Spule	LC	Ceramic coil	LC	Bobine céramique
LD	Netz-, HF-Drossel, Df-Filter	LD	Choke, lead-through filter	LD	Self de choc, filtre de traversée
LE	Einzelkreis, Bandfilter	LE	Single tuned circuit, bandpass filter	LE	Circuit accordé, filtre passe-bande
LF	Ferrilkern mit Zubehör	LF	Ferrite cores with accessories	LF	Noyaux en ferrite avec accessoires
LK	Karbonyleisenkern und elektrischer Kupferkern mit Zubehör	LK	Iron carbonyl slugs and copper slugs with accessories	LK	Noyaux en fer carbonyle et en cuivre, avec accessoires
LL	Luftpule	LL	Air-core coils	LL	Bobines à air
LM	Magnetband und -platte	LM	Magnetic tapes and disks	LM	Bandes et disques magnétiques
LS	Schirmbecher	LS	Screening cans	LS	Boîtiers de blindage
LT	Netztransformator	LT	Power transformer	LT	Transformateur secteur
LU	NF-Übertrager	LU	AF transformer	LU	Transformateur BF
LV	Variometer	LV	Variometer	LV	Variomètre
LW	Wickelkörper, allgemein	LW	Coil formers, general	LW	Carcasses de bobine, en général

Teilefamilie	Art des Bauelementes	Parts family	Type of component	Familie	Type d'element
R	Widerstände	R	Resistors	R	Résistances
RD	Drahtwiderstand	RD	Wire-wound resistor	RD	Résistance bobinée
RF	Kohleschicht-Widerstand	RF	Carbon-film resistor	RF	Résistance à couche de carbone
RG	Metallglasur-Widerstand	RG	Metal-coated resistor	RG	Résistance à couche métallique
RJ	Metalloxyd-Widerstand	RJ	Metal-oxide resistor	RJ	Résistance à oxyde métallique
RK	Kaltleiter, Heißleiter, Varistor	RK	PTC, NTC resistors, varistors	RK	Résistances CPT, CNT, varistors
RL	Metallfilm-Widerstand	RL	Metal-film resistor	RL	Résistance à film métallique
RN	Widerstandsnetzwerk	RN	Resistor network	RN	Réseau de résistance
RR	Draht-Potentiometer	RR	Wire-wound potentiometer	RR	Potentiomètre bobiné
RS	Schicht-Potentiometer	RS	Carbon-film potentiometer	RS	Potentiomètre à couche
RT	Dämpfungsglied, Abschlußwiderstand	RT	Attenuator, termination	RT	Atténuateur, charge
RV	Drahtwiderstand mit Abgriff	RV	Wire-wound resistor, tapped	RV	Résistance bobinée à prise
RW	Wendelpotentiometer	RW	Helical potentiometer	RW	Potentiomètre hélicoïdal
S	Schalter, Relais, Sicherungen	S	Switches, relays, fuses	S	Commutateurs, relais, fusibles
SB	Drucktastenschalter	SB	Pushbutton switch	SB	Commutateur à touche
SD	Drehschalter	SD	Rotary switch	SD	Commutateur rotatif
SF	Kontaktfedersatz	SF	Spring contact assembly	SF	Jeu de ressorts de contact
SH	HF-Koaxialschalter, -Relais, -Teiler	SH	Coaxial RF switch, RF relay, RF attenuator	SH	Commutateur RF coaxial, relais RF, atténuateur RF
SK	Kipp-, Wipp- und Schiebeschalter	SK	Toggle switch, slide switch	SK	Commutateur à bascule, à glissière
SL	Leistungsschalter Netz/HF	SL	AC supply switch, high-power RF switch	SL	Commutateur secteur, de puissance RF
SM	Mikroschalter	SM	Microswitch	SM	Microrupteur
SN	Elektromagnet, Relais	SN	Electromagnetic relay	SN	Relais électromagnétique
SP	Leistungsrelais, Luftschtütz	SP	Power relay, air-type contactor	SP	Relais de puissance, contacteur à air
SR	Reedrelais	SR	Reed relay	SR	Relais reed
SS	Sicherung, Schutzschalter	SS	Fuse, automatic cut-out	SS	Fusible, coupe-circuit automatique
ST	Thermoschalter	ST	Thermal circuit breaker	ST	Disjoncteur thermique
SU	Überspannungs-Ableiter	SU	Arrester	SU	Eclateur
SW	Wechselrichter, Näherungsschalter	SW	Inverter (DC-AC), proximity switch	SW	Inverseur (DC-AC), commutateur de proximité
SZ	Zeitschalter	SZ	Time switch	SZ	Interrupteur horaire
V	Verbindungselemente	V	Connecting elements	V	Eléments de raccordement
VK	Klemme, Klemmleiste	VK	Clamp, terminal strip	VK	Pince, réglette à bornes
VL	Lötöse, Stützpunkt	VL	Soldering lug	VL	Cosse à souder
VS	Schraube, Mutter, Scheibe	VS	Screw, nut, washer	VS	Vis, écrou, disque

Farbcode für Widerstände und Kondensatoren

Anmerkung:

Die Wertangabe der weitgehend miniaturisierten Bauelemente erfolgt überwiegend durch Farbkennzeichnungen, deren Bedeutung der nachfolgenden Tabelle entnommen werden kann

Hinweis:

Im Zuge des technischen Fortschrittes setzt R&S zunehmend Metallschichtwiderstände mit 1% Toleranz anstelle von Kohleschichtwiderständen mit 5% Toleranz ein. Metallschichtwiderstände können sich dabei an Stellen befinden, an denen gemäß Schaltteilliste Kohleschichtwiderstände vorgesehen sind. Etwaige geringfügige Differenzen der Nennwerte zwischen Stromlaufplan, Schaltteilliste und Gerät liegen im zulässigen Toleranzbereich.

Colour code for resistors and capacitors

Note:

The electrical values of the largely miniaturized components are mainly identified by a colour code, the meaning of which can be taken from the table below.

N. B.:

Following the state of the art R&S makes increasing use of metal-film resistors (1% tolerance) instead of carbon-film resistors (5% tolerance). Metal-film resistors may have been employed where carbon-film resistors are specified in the parts list. Any slight differences of nominal values between circuit diagram, parts list and equipment are within tolerance.

Code couleur pour résistances et condensateurs

Remarque:

Les valeurs électriques des composants fort miniaturisés sont indiquées dans la plupart des cas par un code couleur dont voici l'explication.

N. B.:

Suivant le progrès technique R&S utilise de plus en plus des résistances à film métallique (tolérance 1%) au lieu des résistances à couche de carbone (tolérance 5%). Des résistances à film métallique peuvent se trouver en des points où des types à couche de carbone figurent dans la liste des composants. Les différences minimales des valeurs nominales existant éventuellement entre le schéma de circuit, la liste des composants et l'appareil sont dans la marge de tolérance.

Farbe/Colour/Couleur	A	B	C	D	Anordnungsbeispiele für Examples for / Exemple pour	Definition / Définition *
Schwarz/Black/Noir	—	0	—	—	Widerstände (R) / Resistors (R) / Résistance (R)	Kennzeichen A (Bauteilfarbe/1. Farbring) = 1. Zahl (Bauteilende/2. Farbring) = 2. Zahl (Punkt/3. Farbring) = 3. Zahl = Zahl der Nullen (Punkt/4. Farbring) = Toleranz des Nennwerts in % (Fehlendes Kennzeichen für D bedeutet ±20%) Das Fehlen eines Kennzeichens bedeutet, daß die Farbe des Bauteilkörpers die Wertangabe darstellt. Marking A (body colour or first coloured ring) = 1st digit (body end or second coloured ring) = 2nd digit (dot or third coloured ring) = number of zeroes (dot or fourth coloured ring) = tolerance on nominal value in % (with no D marking tolerance = 20%) The absence of a marking signifies that the body colour gives the corresponding information. Reperage A (couleur du corps ou 1er anneau) = 1er chiffre (bout du corps ou 2e anneau) = 2e chiffre (point ou 3e anneau) = nombre de zéros (point ou 4e anneau) = tolérance en % de la valeur nominale (L'absence du reperage D signifie ±20%) L'absence de tout reperage signifie que la couleur du corps du composant représente la valeur correspondante
Braun/Brown/Marron	1	1	0	± 1%		
Rot/Red/Rouge	2	2	00	± 2%		
Orange/Orange	3	3	000	—		
Gelb/Yellow/Jaune	4	4	0000	—		
Grün/Green/Vert	5	5	00000	± 0,5%		
Blau/Blue/Bleu	6	6	000000	—		
Violett/Violet	7	7	—	± 0,1%		
Grau/Gray/Gris	8	8	—	—		
Weiß/White/Bianc	9	9	—	—		
Gold/Dore	—	—	—	± 5%		
Silber/Silver/Argente	—	—	—	± 10%		
Ohne Farbe/No colour/ Pas de couleur	—	—	—	± 20%		

1) Toleranzring, hier nicht spezifiziert

1) Tolerance ring, here not specified

1) Anneau de tolérance, ne pas spécifier ici

* Siehe auch DIN 41429 und DIN 40825

* see also IEC publication 62-1952 and 62-1968

* Voir aussi DIN 41429 et DIN 40825



Zusammenstellung der lieferbaren Netzkabel
List of power cables available
Liste des câbles d'alimentation disponibles

Sach-Nr. Stock No. Référence	Schutzkontaktstecker nach: Earthed-contact connector: Fiche à contact de protection:	Vorzugsweise verwendet in: Preferably used in: Utilisé de préférence en:
DS 006.7013	BS 1363: 1967' 13A entspr. IEC 83: 1975 Standard B2 BS 1363: 1967' 13A complying with IEC 83: 1975 Standard B2 BS 1363: 1967' 13A suivant CEI 83: 1975 norme B2	Großbritannien Great Britain Grande-Bretagne
DS 006.7020	Typ 12 nach SEV-Vorschrift 1011.1059, Normblatt S 24 507 Type 12 complying with SEV regulation 1011.1059, standard sheet S 24 507 Type 12 suivant la norme SEV 1011.1059, feuille S 24 507	Schweiz Switzerland Suisse
DS 006.7036	Typ 498/13 nach USA-Vorschrift UL 498, bzw. IEC 83 Type 498/13 complying with US regulation UL 498 or with IEC 83 Type 498/13 suivant la norme E.U.A. UL 498 ou la norme CEI 83	USA / Kanada USA / Canada E.U.A. / Canada
DS 006.7107	Typ SAA3 10 A, 250 V, nach AS C112-1964 Ap. Type SAA3 10 A, 250 V, complying with AS C112-1964 Ap. Type SAA3 10 A, 250 V, suivant AS C112-1964 Ap.	Australien Australia Australie
DS 025.2365	DIN 49 441, 10 A, 250 V	Europa (ohne Schweiz) Europe (Switzerland not included) Europe (Suisse non comprise)

Cross-Reference List of Class Designation Letters

IEC Publication 113-2 (1971) Item Designations, Letter Codes
ANSI Y32.2-1975 (IEEE Std 315-1975), Section 22, Class Designation Letters

Note: The designation letters used in the R&S Manuals correspond to the letter codes of the IEC Standard identified in the first column!

IEC Publication 113-2 Terminology	Letter Code		IEC Publication 113-2 Terminology	Letter Code	
	IEC	Y32.2		IEC	Y32.2
Acoustical indicator	H	LS	Magnetic tape recorder	D	A
Adjustable resistor	R	R	Maser	A	A
Aerial	W	E	Measuring equipment	P	M
Amplifier	A	AR	Microphone	B	MK
Amplifier (with tubes)	A	AR	Miscellaneous	E	E
Arrester	F	E	Modulator	U	A
Assemblies	A	A,U	Monostable element	D	A,U
Auxiliary switch	S	S	Motor	M	B
Battery	G	BT	Optical indicator	H	DS
Bistable element	D	U,A	Oscillator	G	Y,G
Brake	Y	MP	Overvoltage discharge device	F	F,E
Busbar	W	W	Parabolic aerial	W	E
Cable	W	W	Photoelectric cell	B	V
Cable balancing network	Z	Z	Pickup	B	PU
Capacitor	C	C	Plug	X	P
Changer	U	A,B,G,MT	Pneumatic valve	Y	MP
Circuit breaker	Q	CB	Potentiometer	R	R
Clutch	Y	MP	Power switchgear	Q	CB,S
Coder	U	U,A	Protective device	F	F
Comander	Z	A	Pushbutton	S	S
Connecting stage	S	S	Quartz-oscillator	G	Y
Contactors	K	K	Recording device	P	A,M
Control switch	S	S	Register	D	A,U,M
Converter	U	A,U,MG	Relay	K	K
Core, storage	D	E	Resistor	R	R
Crystal filter	Z	FL	Resolver	B	B
Crystal transducer	B	Y	Rheostat	R	R
Current transformer	T	T	Rotating frequency generator	G	G,MG
Delay device	D	DL	Rotating generator	G	G
Delay line	D	DL	Selector	S	S
Demodulator	U	A	Selector switch	S	S
Dial contact	S	S	Semiconductor	V	D,CR,Q
Diode	V	D	Shunt (resistor)	R	R
Dipole	W	E	Signal generator	P	A
Disconnecting plug	X	P	Signaling device	H	DS
Disconnecting socket	X	X	Socket	X	X
Discriminator	U	A	Soldering terminal strip	X	E,TB
Disk recorder	D	A	Static frequency changer	U	A
Dynamotor	B	MG	Storage device	D	A,U
Electrically operated mechanical device	Y	MT	Subassembly	A	A
Electronic tube	V	V	Supply	G	A,PS
Equalizer	Z	EQ	Supply device	G	A,PS
Filter	Z	FL	Synchro	B	B
Frequency changer	U	A,B,G	Telegraph translator	U	A
Fuse	F	F	Terminal	X	E
Gas discharge tube	V	V	Terminal board	X	TB
Generator	G	G	Termination	Z	AT
Heating device	E	HR	Test jack	X	E,J
Hybrid	Z	Z	Testing equipment	P	A
Indicating device	P	DS	Thermistor	R	RT
Induction coil	L	L	Thermo cell	B	A,TC
Inductors	L	L	Thermoelectric sensor	B	A
Integrating measuring device	P	M,MT,Z	Thyristor	V	Q
Inverter	U	A,U,PS,MG	Transducer (nonelectrical quantity to electrical quantity)	B	A,BT
Isolator	Q	AT	Transformer	T	T
Jumper wire	W	W	Transmission path	W	W
Laser	A	MT,A	Transistor	V	Q
Lighting device	E	DS	Tube (electron)	V	V
Limit switch	S	S	Voltage transformer (potential)	T	T
Limiter	Z	MT,RE	Waveguide	W	W
Line trap	L	FL,MP,V	Waveguide directional coupler	W	DC
Loudspeaker	B	LS			
Magnetic amplifier	A	AR			

Schaltteillisten
numerisch geordnet
Part lists
in numerical order
Listes des pièces détachées
par numéros de référence

Für diese Unterlage behalten wir uns alle Rechte vor.

Kannz. Comp. No.	Benennung Designation	Sachnummer Stock No.	Hersteller Manufacturer	Bezeichnung Designation	enthalten in contained in	
	XX VARIANTENERKLÄRUNG IDENTIFICATION OF MODELS VAR 11 = SMY01 1GHZ MOD. MOD 11 = SMY01 1GHZ MOD. VAR 12 = SMY02 1GHZ MOD. MOD 12 = SMY02 1GHZ MOD VAR 41 = SMY41 1GHZ UK MOD 41 = SMY41 1GHZ UK VAR 43 = SMY43 MOD 43 = SMY43 VAR 44 = SMY44 1GHZUPGRAD MOD 44 = SMY44 1GHZUPGRAD VAR 45 = SMY45 2GHZUK MOD 45 = SMY45 2GHZUK XX ZUGEH. STROML. CIRC. DIAGR. 1062.5502 S					
A1	ED TASTATUR/ANZEIGE KEYBOARD/DISPLAY HIERZU STROML. 1062.6809S SEE CIRC. DIAGR. 1062.6809S	1062.6809.02				
A2	ED PROCESSOR PROCESSOR NUR VAR/ONLY MOD: 11 12 43 HIERZU STROML. 1062.6309S SEE CIRC. DIAGR. 1062.6309S	1062.6309.02				
A2	ED PROZESSOR NUR VAR/ONLY MOD: 41 44 45	1062.6309.04				
A3	ED MOTHERBOARD MOTHERBOARD HIERZU STROML. 1062.6009S SEE CIRC. DIAGR. 1062.6009S	1062.6009.02				
A4	EE SYNTHESIZER SYNTHESIZER NUR VAR/ONLY MOD: 11 12 HIERZU STROML. 1062.6409S SEE CIRC. DIAGR. 1062.6409S	1062.6409.02				
A4	EE SYNTHESIZER NUR VAR/ONLY MOD: 41 44 45 HIERZU STROML. 1062.6409S SEE CIRC. DIAGR. 1062.6409S	1062.6409.04				
A4	EE SYNTHESIZER SYNTHESIZER NUR VAR/ONLY MOD: 43 HIERZU STROML. 1062.6409S SEE CIRC. DIAGR. 1062.6409S	1062.6409.43				
A5	EE AUSGANGSTEIL 1.046GHZ OUTPUT STAGE 1,0 GHZ NUR VAR/ONLY MOD: 11 HIERZU STROML. 1062.6209S SEE CIRC. DIAGR. 1062.6209S	1062.6209.02				
A5	EE AUSGANGSTEIL 1.046GHZ NUR VAR/ONLY MOD: 41 HIERZU STROML. 1062.6209S SEE CIRC. DIAGR. 1062.6209S	1062.6209.04				
A5	EE AUSGANGSTEIL 2.08GHZ OUTPUT UNIT 2.08GHZ NUR VAR/ONLY MOD: 12 43 HIERZU STROML. 1062.7005 S SEE CIRC. DIAG. 1062.7005 S	1062.7005.02				
A5	EE AUSGANGSTEIL NUR VAR/ONLY MOD: 44 45 HIERZU STROML. 1062.7005S SEE CIRC. DIAG. 1062.7005S	1062.7005.04				
A6	ZE EICHLITUNG (SMX) ATTENUATOR (SMX) NUR VAR/ONLY MOD: 11	0826.5065.02				
A6	ZE EICHLITUNG (SMY) NUR VAR/ONLY MOD: 41	0826.5065.04				
A6	ZE EICHLITUNG (SMG/SMH) NUR VAR/ONLY MOD: 12 43	0801.1108.02				
A6	ZE EICHLITUNG (SMY) NUR VAR/ONLY MOD: 44 45	0801.1108.04				
A7	ZE NETZTEIL, EINHEIT POWER SUPPLY HIERZU STROML. 1062.5690S	1062.5690.02				
MENP5	413 3PUA	ÄI	Datum Date	Schaltteilliste für Parts list for	Sachnummer Stock No.	Blatt-Nr. Page
	ROHDE & SCHWARZ	11	16.09.97	GG SMY... SIGNAL GENERAT.	1062.5502.01 SA	1+

Auch für neue Geräte neuer AEZ

095.0026-0893

Für diese Unterlage behalten
wir uns alle Rechte vor.

Kennz. Comp. No.	Benennung Designation	Sachnummer Stock No.	Hersteller Manufacturer	Bezeichnung Designation	enthalten in contained in	
A13	SEE CIRC. DIAGR. 10625690S ED ALC-BOARD ALC-BOARD NUR VAR/ONLY MOD: 41 44 45	1062.9920.02				
W1	DW KABEL W1 CABLE W1	1062.6538.00	SMY01		1062.6521.00 F	
W1	DW KABEL W1 CABLE W1	1062.6596.00	SMY02		1062.6580.00	
W2	DY KABEL W2 CABLE W2	1062.6644.00			1062.6621.00	
W4	DY KABEL W4 CABLE W4	1062.6650.00			1062.6621.00	
W20	DY KABEL W20 CABLE W20	1062.6667.00			1062.6621.00	
W24	DV KABEL CABLE	1062.6544.00			1062.6509.00	
W25	DV KABEL CABLE	1062.6544.00			1062.6509.00	
W26	DW KABEL W26 CABLE	1062.6567.00	SMY01		1062.6521.00 F	
W26	DW KABEL W26 CABLE W26	1062.6609.00	SMY02		1062.6580.00	
W27	DV KABEL W27 CABLE W27	1062.6573.00			1062.6509.00	
W131	DV HF-KABEL-W131 NUR VAR/ONLY MOD: 41 44 45	1063.0027.00				
W132	DV HF-KABEL NUR VAR/ONLY MOD: 41 44 45	1063.0033.00				
W133	DV HF-KABEL W133 NUR VAR/ONLY MOD: 41 44 45	1063.0040.00				
X101	FJ EINBAUBUCHSE SYST.BNC BNC-CONNECTOR UG 625CIU NUR VAR/ONLY MOD: 11 12 43	FJ 0099.9186.00	ROSENBERGE	51K-503-200-N4		
X102	FJ EINBAUBUCHSE SYST.BNC BNC-CONNECTOR UG 625CIU	FJ 0099.9186.00	ROSENBERGE	51K-503-200-N4		
X103	FJ EINBAUBUCHSE SYST.BNC BNC-CONNECTOR UG 625CIU	FJ 0099.9186.00	ROSENBERGE	51K-503-200-N4		
X104	FJ EINBAUBUCHSE SYST.BNC BNC-CONNECTOR UG 625CIU NUR VAR/ONLY MOD: 11 12 43	FJ 0099.9186.00	ROSENBERGE	51K-503-200-N4		
X105	FJ EINBAUBUCHSE SYST.BNC BNC-CONNECTOR UG 625CIU	FJ 0099.9186.00	ROSENBERGE	51K-503-200-N4		
X133	FJ EINLOETBUCHSE MMCX SMD CONNECTOR NUR VAR/ONLY MOD: 41 44 45	1075.4045.00	SUHNER	90MMCX-S50-0-51/1190		
MENP5	413 3PUA	Ä1	Datum Date	Schaltteilliste für Parts list for	Sachnummer Stock No.	Blatt-Nr. Page
		11	16.09.97	GG SMY... SIGNAL GENERAT.	1062.5502.01 SA	2-

Für diese Unterlage behalten wir uns alle Rechte vor.

Kennz. Comp. No.	Benennung Designation	Sachnummer Stock No.	Hersteller Manufacturer	Bezeichnung Designation	enthalten in contained in	
.	XX VARIANTENERKLAERUNG IDENTIFICATION OF MODELS VAR02=GRUNDAUSFUEHRUNG MODO2=BASIC_MODEL					
W3	DY KABEL W3 CABLE W3	1062.6080.00			1062.6067.00	
W21	DY KABEL W21 CABLE W21	1062.6096.00			1062.6067.00	
W77	DY KABEL W77 CABLE W77	1062.6109.00			1062.6067.00	
X1	FP BUCHSENLEISTE 32POL. CONNECTOR 32POL.	FP 0008.5676.00	SIEMENS	V42254-B2201-B611		
X2	FP BUCHSENLEISTE 32POL. CONNECTOR 32POL.	FP 0008.5676.00	SIEMENS	V42254-B2201-B611		
X4	FP STECKERLEISTE 10P.GER CONNECTOR 10P	0846.4593.00	SIEMENS	V23535-A2200-A102		
X20	FP STECKERLEISTE 10P.GER CONNECTOR 10P	0846.4593.00	SIEMENS	V23535-A2200-A102		
X33	FP STIFTL.WIN 3P.R2,54 ANGLE PIN CONNECTOR	FP 0009.7195.00				
X125	FJ EINLOETBUCHSE MMCX SMD CONNECTOR	1075.4045.00	SUHNER	90MMCX-S50-0-51/1190		
X133	FJ EINLOETBUCHSE MMCX SMD CONNECTOR	1075.4045.00	SUHNER	90MMCX-S50-0-51/1190		
X231	NICHT BESTUECKT/NOT FITTED ENTHALTEN IN SMY-B40 ZUB 1062.9920.02 FP STECKERLEISTE 10P.WIN CONNECTOR NICHT BESTUECKT NOT FITTED	FP 0738.5335.00	SIEMENS	V23535-A2210-A102		
MENP5	413 3PUA	ÄI	Datum Date	Schaltteilliste für Parts list for	Sachnummer Stock No.	Blatt-Nr. Page
	01	16.09.97	ED MOTHERBOARD MOTHERBOARD	1062.6009.01 SA	1-	

095.0026-0693

XY-Liste

XY List

Erklärung der Spaltenbezeichnungen:

- Part:** Bauelement-Kennzeichen.
- Side:** Leiterplatten-Seite, auf der sich das Bauelement befindet.
- X/Y:** Koordinaten (Millimeter) des Bauelementes auf der Leiterplatte bezogen auf den Nullpunkt.
- SQR, PG:** Planquadrat und Seite des Schaltbildes für das jeweilige Bauelement.

Explanation of column designations:

- Part:** Identification of instrument part.
- Side:** Side of the PC board on which instrument part is positioned.
- X/Y:** Coordinates (millimeter) of the component on the PC board in reference to zero point.
- SQR, PG:** Square and page of the diagram for the respective instrument part.

Nicht-Service-Relevante Bauteile / Non-Service-Relevant Components																	
Part	Side	X	Y	Sqr	Pg	Part	Side	X	Y	Sqr	Pg	Part	Side	X	Y	Sqr	Pg
W3	B	113	10	4D	1	X2	B	38	77	3A	1	X125	B	10	90	1A	1
W21	B	114	27	7D	1	X4	B	137	13	2A	1	X133	B	44	26	1B	1
W77	B	17	51	2D	1	X20	B	23	23	1D	1	X231	B	15	13	3D	1
X1	B	38	41	3C	1	X33	B	41	26	1C	1						

ROHDE	ÄI	Datum	XY-Liste für	Sach-Nummer	Blatt
&		Date	XY-list for	Stock-Nr	Page
SCHWARZ			ED MOTHERBOARD		
	03.00	02.07.97	MOTHERBOARD	1062.6009.01 XY	1-



ROHDE & SCHWARZ

Stromläufe
Bestückungspläne
Circuit diagrams
Components plans
Schémas de circuit
Plans des composants

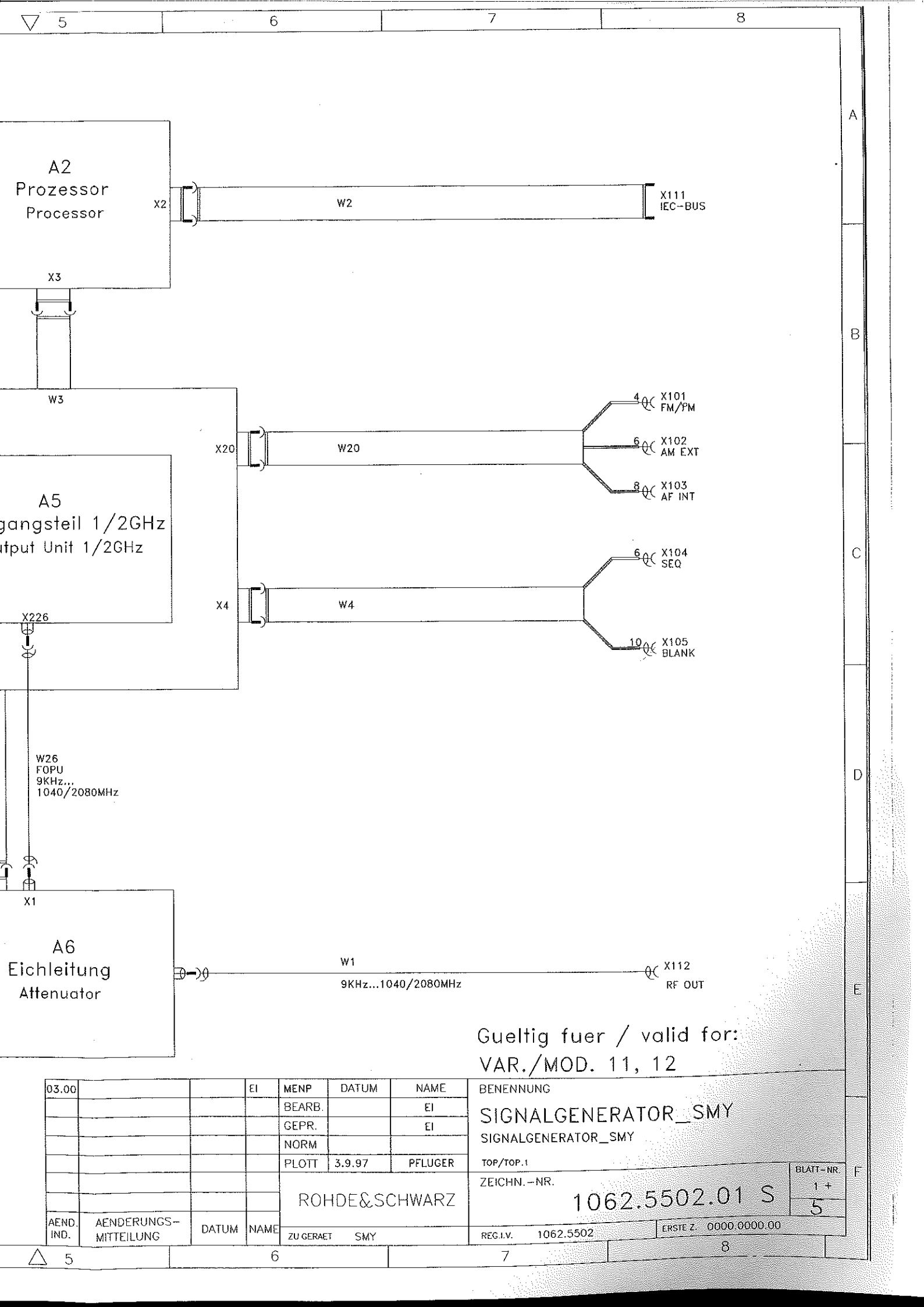

Gueltig fuer / valid for:
 VAR./MOD. 11, 12

03.00			EI	MENP	DATUM	NAME	BENENNUNG
				BEARB.		EI	SIGNALGENERATOR_SMY
				GEPR.		EI	SIGNALGENERATOR_SMY
				NORM			TOP/TOP.1
				PLOTT	3.9.97	PFLUGER	ZEICHN.-NR.
				ROHDE&SCHWARZ			1062.5502.01 S
AEND. IND.	AENDERUNGS-MITTEILUNG	DATUM	NAME	ZU GERAET	SMY	REG.I.V.	1062.5502
						ERSTE Z.	0000.0000.00
							BLATT-NR.
							1+
							5

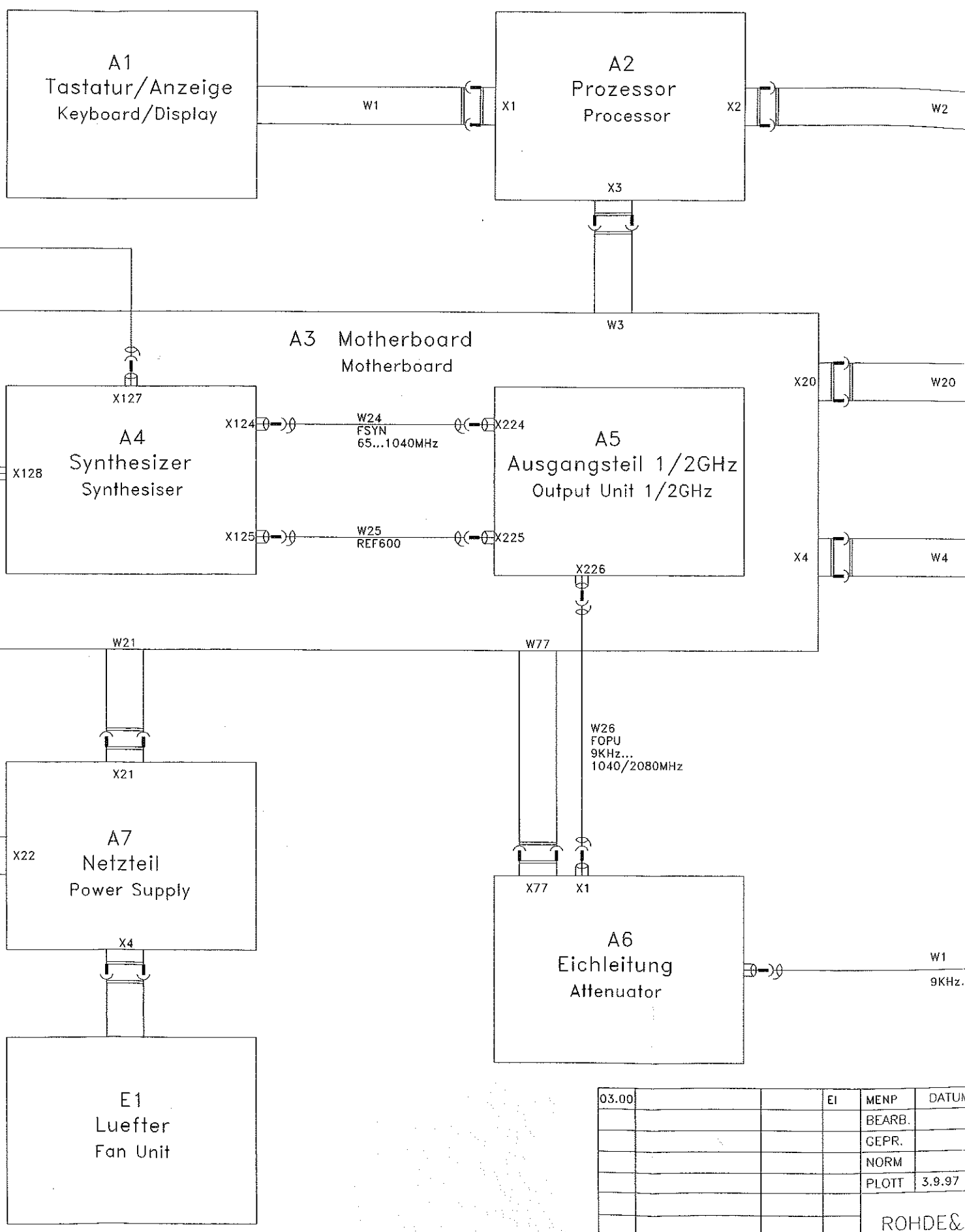

03.00			EI	MENP	DATUM
				BEARB.	
				GEPR.	
				NORM	
				PLOTT	3.9.97
				ROHDE&S	
AEND. IND.	AENDERUNGS-MITTEILUNG	DATUM	NAME	ZU GERAEET	SMY

1

2

3

4

A



W1

B

X110
EXT REF

W27

C

A3 Motherboard
Motherboard

X127

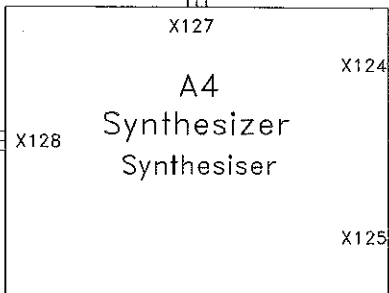

X124

W24
FSYN
65...1040MHz

X128

W28

X125

W25
REF600

D

X711

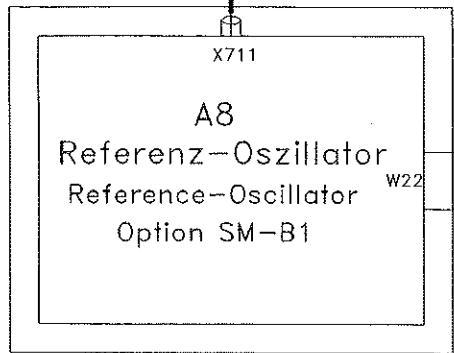

W22

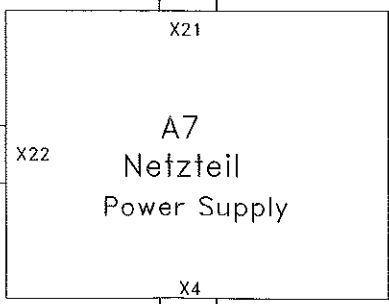

X21

X22

X4

E

Bindende Angaben ueber Varianten,
Trimmwerte, Bauteile und
nicht bestueckte Bouteile siehe SA.

FOR BINDING INFORMATION ON MODELS,
TRIMMING AND COMPONENTS VALUES AND
NONFITTED COMPONENTS SEE PARTS LIST

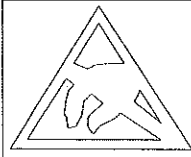

ACHTUNG: EGB !
ELEKTROSTATISCH GEFAEHRDETE
BAUELEMENTE ERFOEDERN EINE
BESONDERE HANDHABUNG.
ATTENTION ESD !
ELECTROSTATIC SENSITIVE DEVICES
REQUIRE A SPECIAL HANDLING

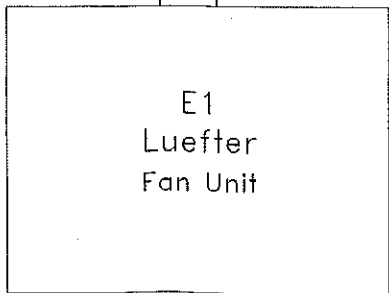

F

1

2

3

4

FUER DIESE UNTERLAGE
BEHALTEN WIR UNS ALLE RECHTE VOR

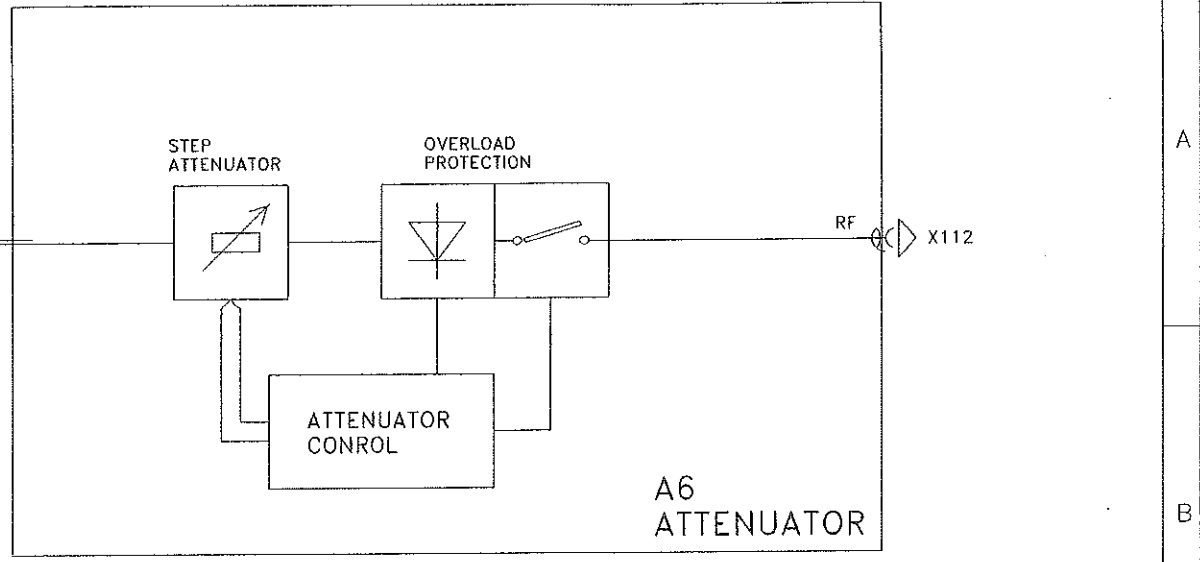

ACHTUNG: EGB !
ELEKTROSTATISCH GEFÄHRDETE
BAUELEMENTE ERFORDERN EINE
BESONDERE HANDHABUNG.
ATTENTION ESD !
ELECTROSTATIC SENSITIVE DEVICES
REQUIRE A SPECIAL HANDLING

Gültig fuer / valid for:
VAR./MOD. 11, 12
Bindende Angaben ueber Varianten,
Trimmwerte, Bauteile und
nicht bestueckte Bauteile siehe SA.
FOR BINDING INFORMATION ON MODELS,
TRIMMING AND COMPONENTS VALUES AND
NONFITTED COMPONENTS SEE PARTS LIST

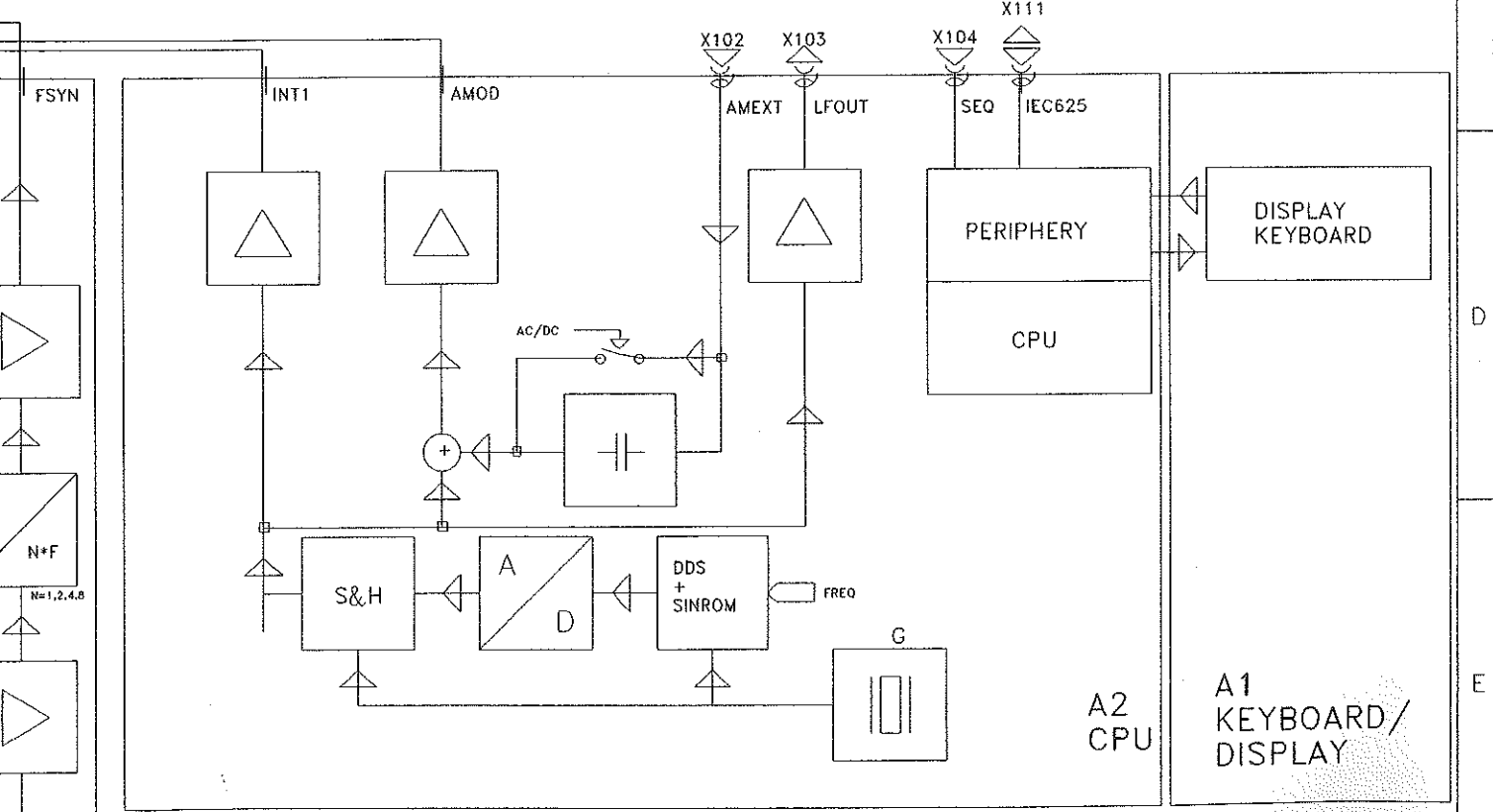

03.00			EI	MENP	DATUM	NAME	BENENNUNG
				BEARB.		EI	SIGNALGENERATOR_SMY
				GEPR.		EI	SIGNALGENERATOR_SMY
				NORM			TOP/TOP.2
				PLOTT	3.9.97	PFLUGER	ZEICHN.-NR.
				ROHDE&SCHWARZ			1062.5502.01 S
AEND. IND.	AENDERUNGS-MITTEILUNG	DATUM	NAME	ZU GERAET	SMY	REG.I.V.	1062.5502
						ERSTE Z.	0000.0000.00

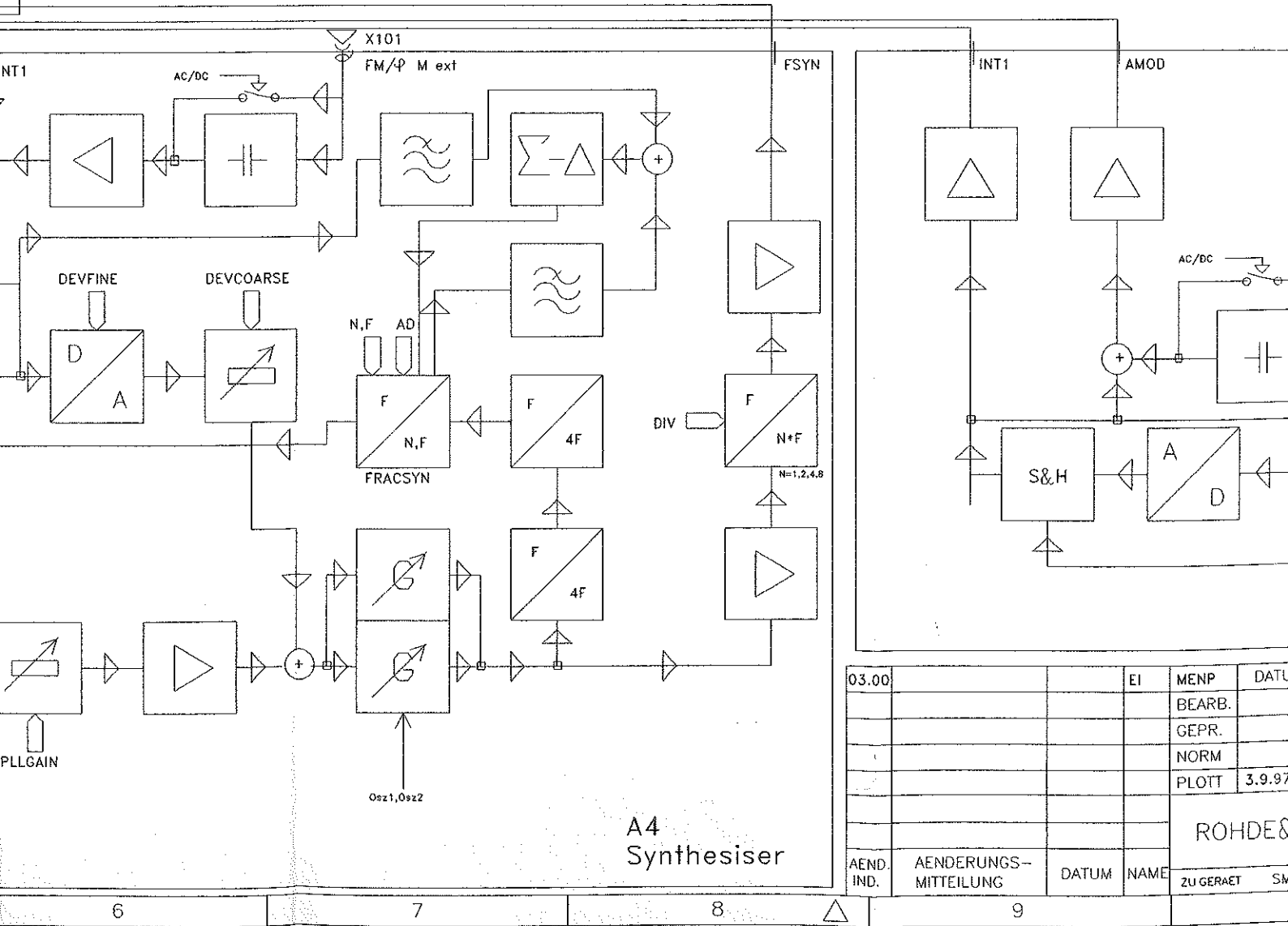
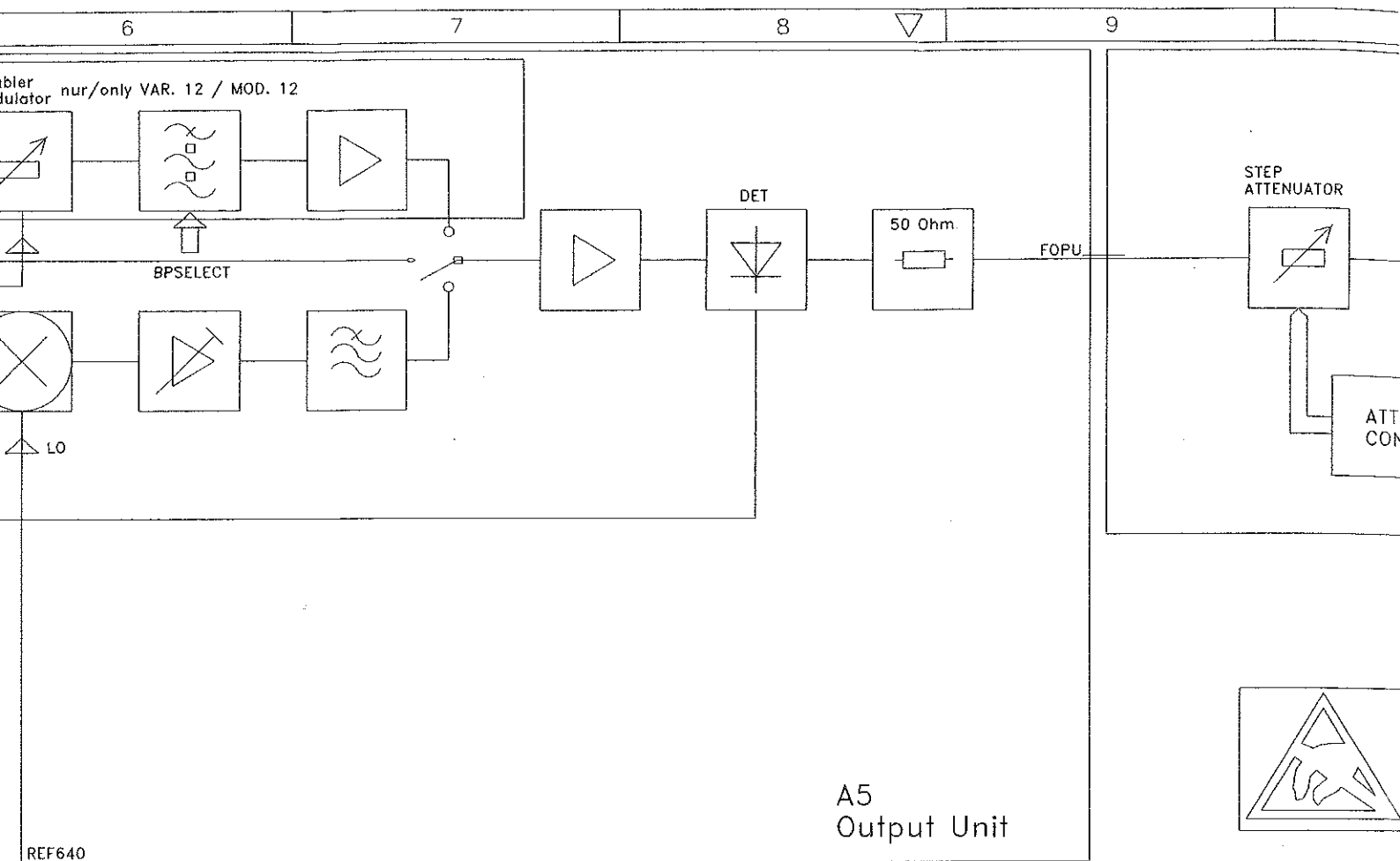

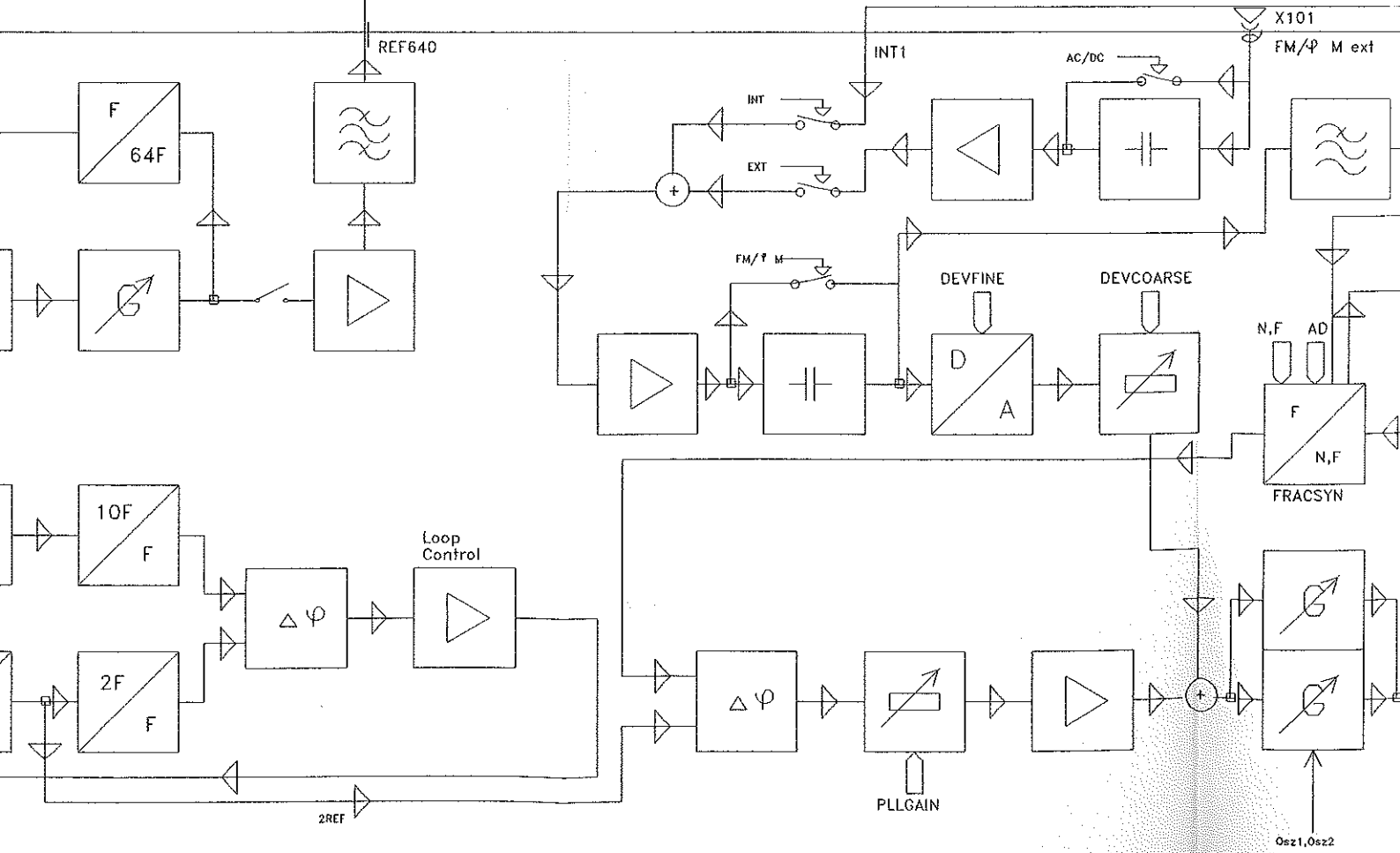
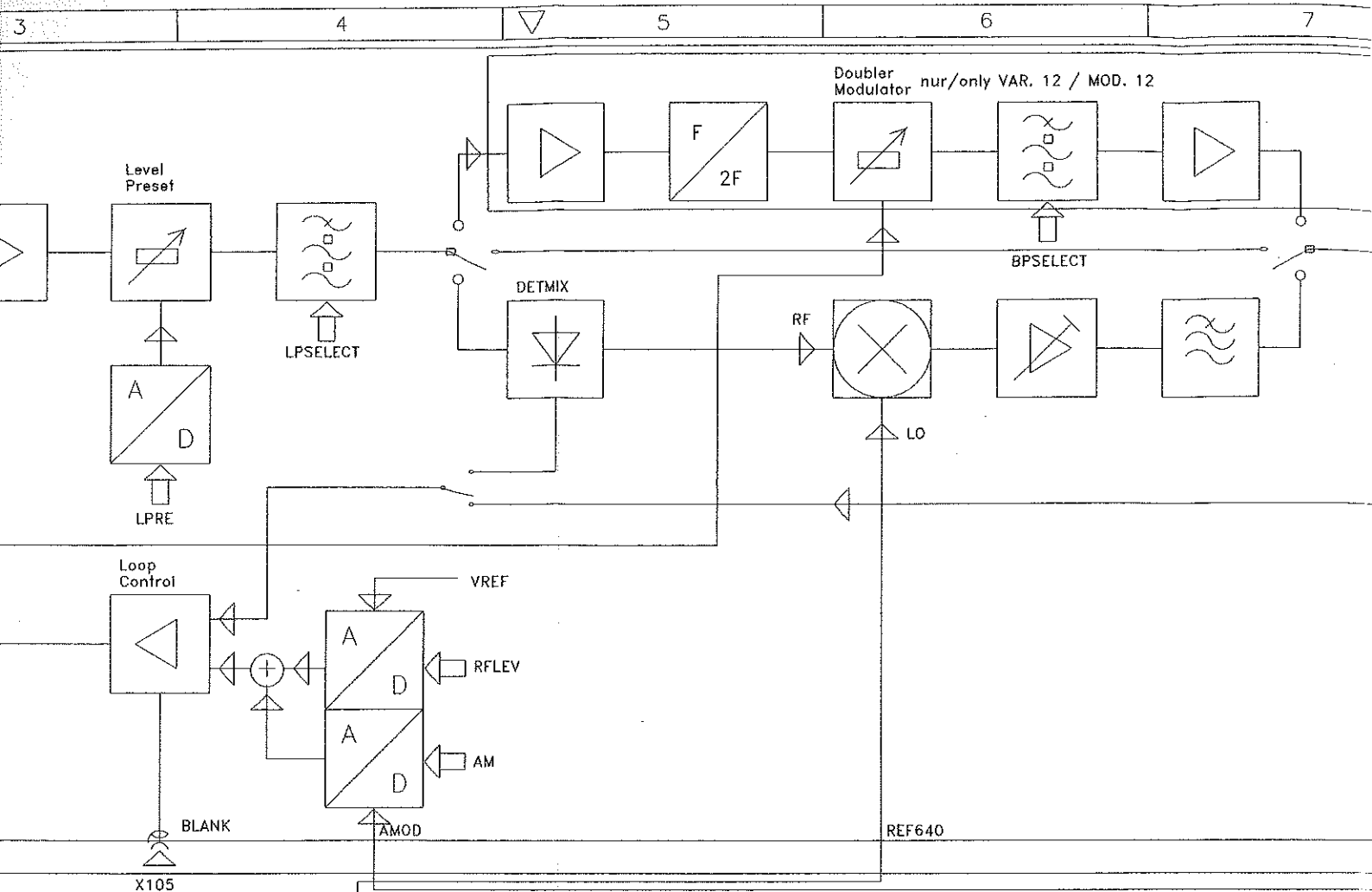

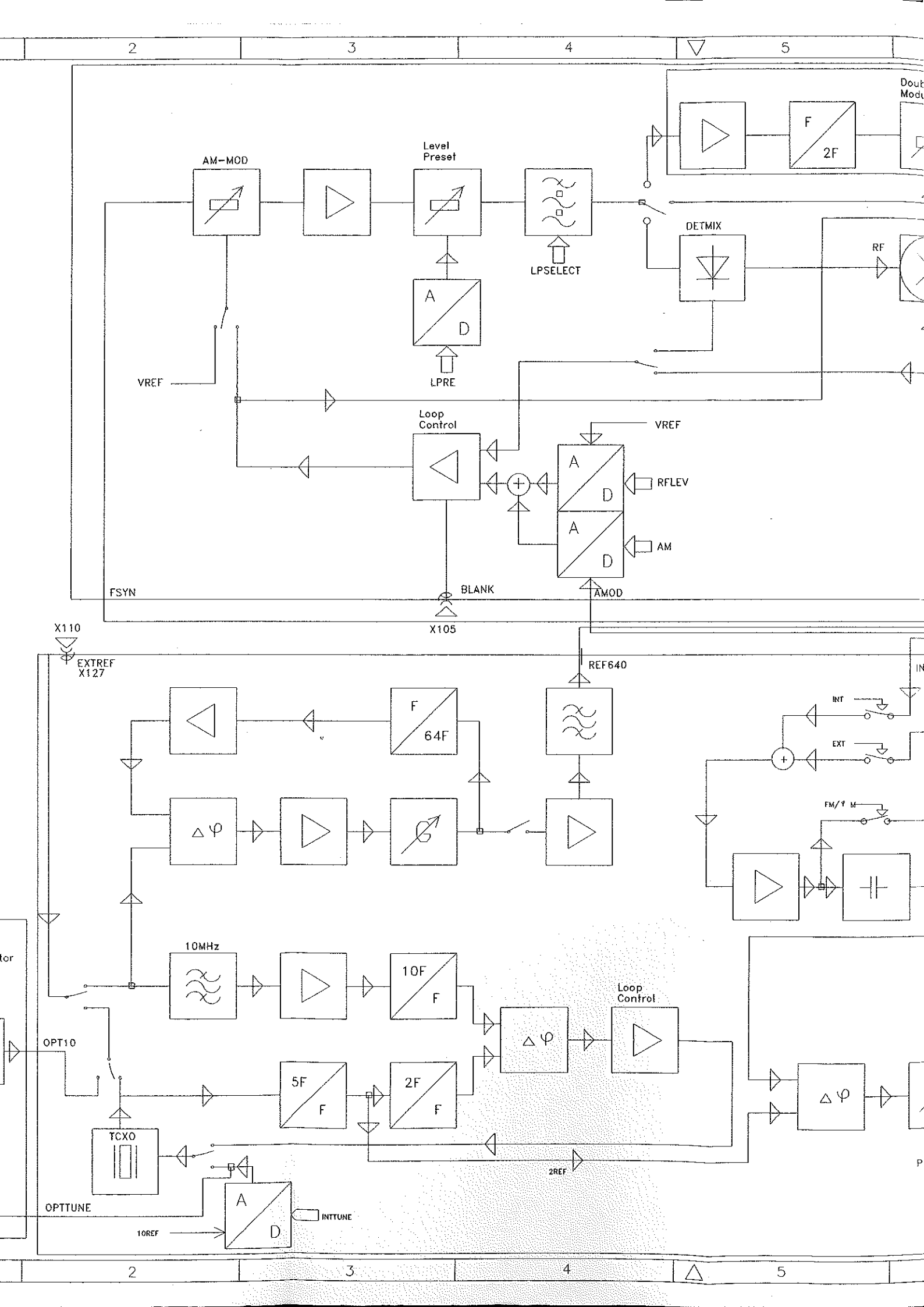

FUER DIESE UNTERLAGE
BEHALTEN WIR UNS ALLE RECHTE VOR

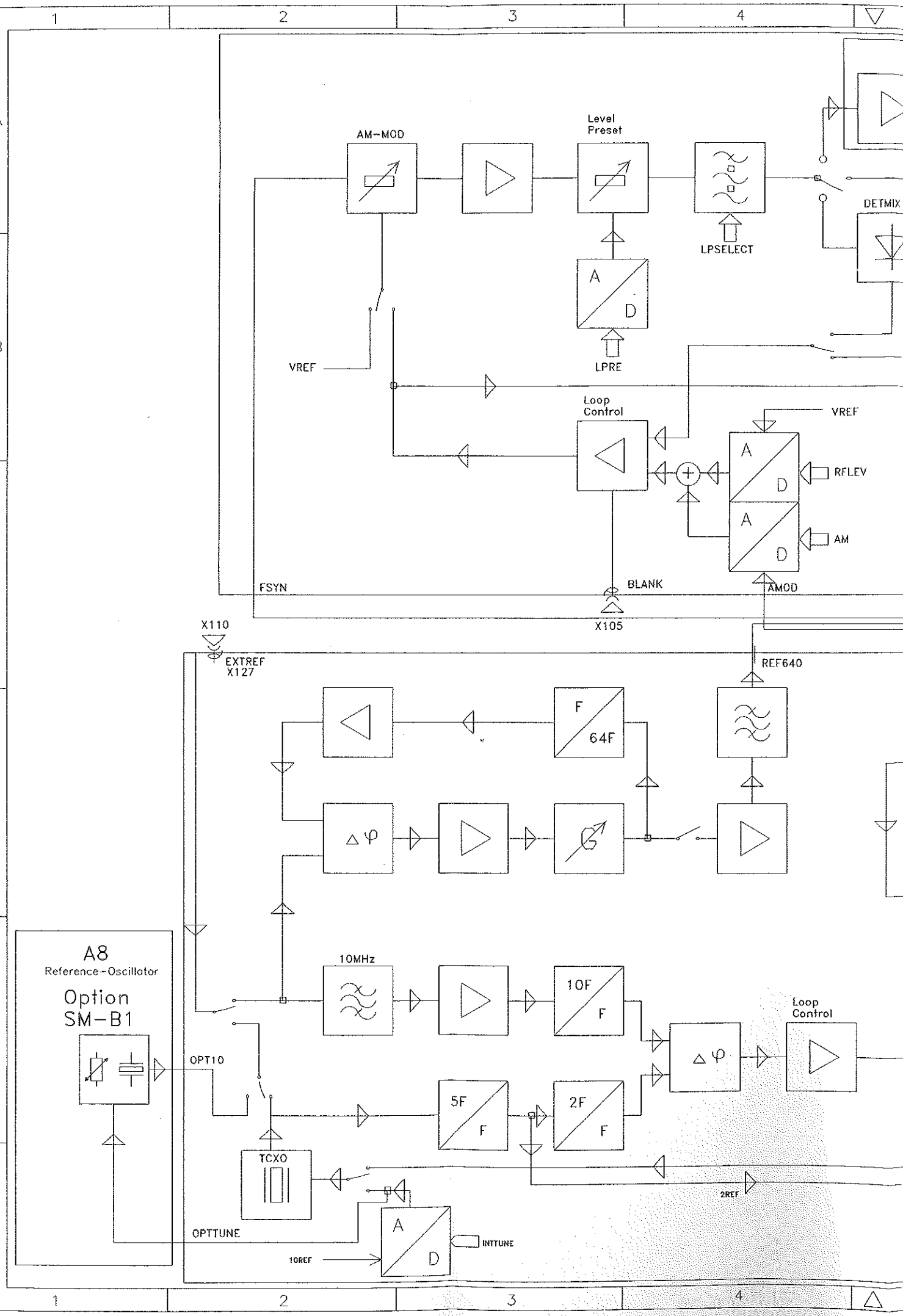

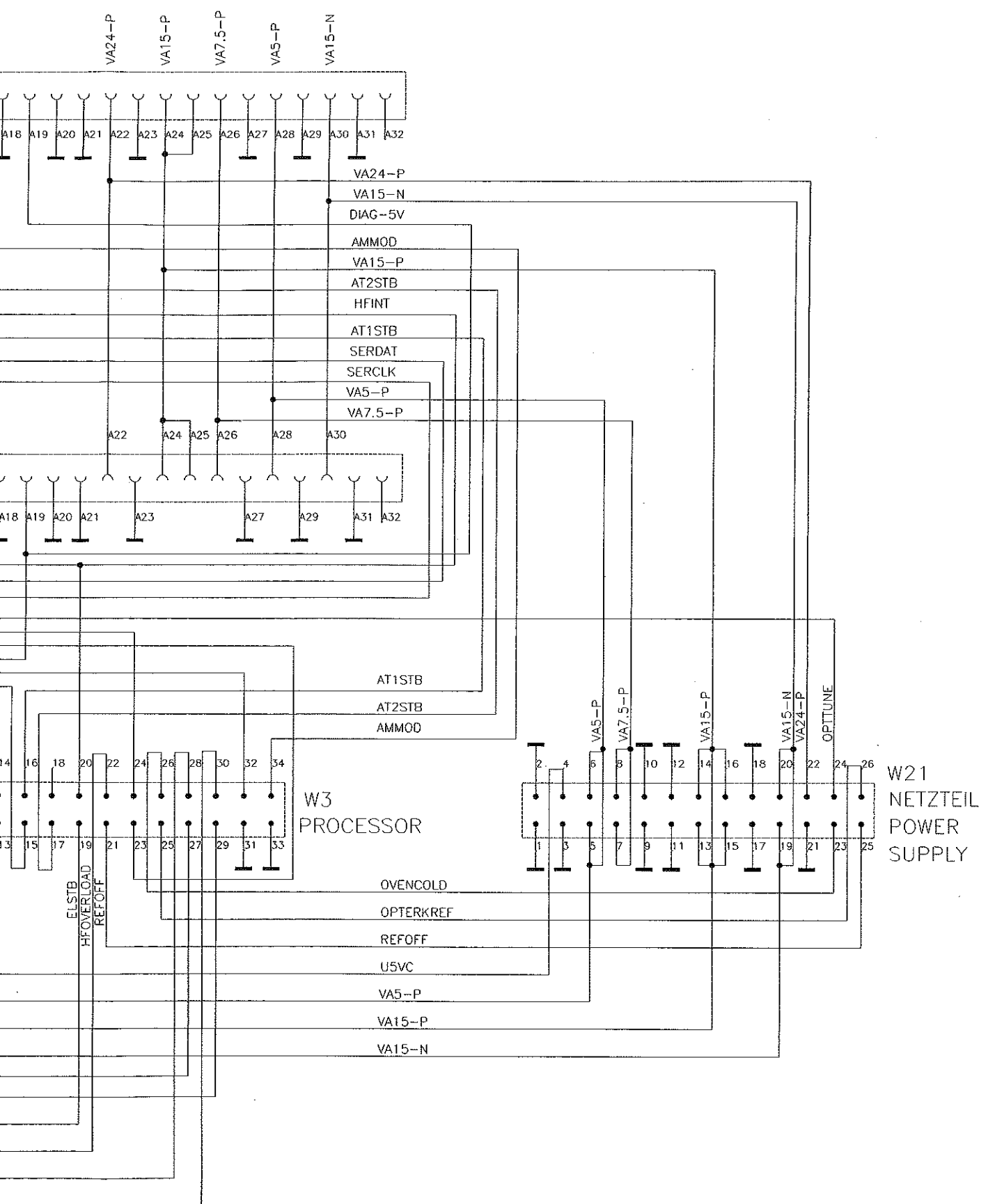

03		08.04.97	PFL	MENP	DATUM	NAME	BENENNUNG	
				BEARB.		PF	MOTHERBOARD	
				GEPR.		PF	MOTHERBOARD	
				NORM				
				PLOTT	18.4.97	PFLUCER	TOP/TOP.1	
				ROHDE&SCHWARZ			ZEICHN.-NR.	BLATT-NR.
							1062.6009.01 S	1-
AEND. IND.	AENDERUNGS-MITTEILUNG	DATUM	NAME	ZU GERAT	SMY	REG.I.V.	1062.5502	ERSTE Z. 1062.5502.01

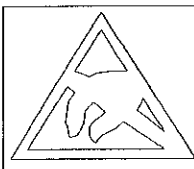
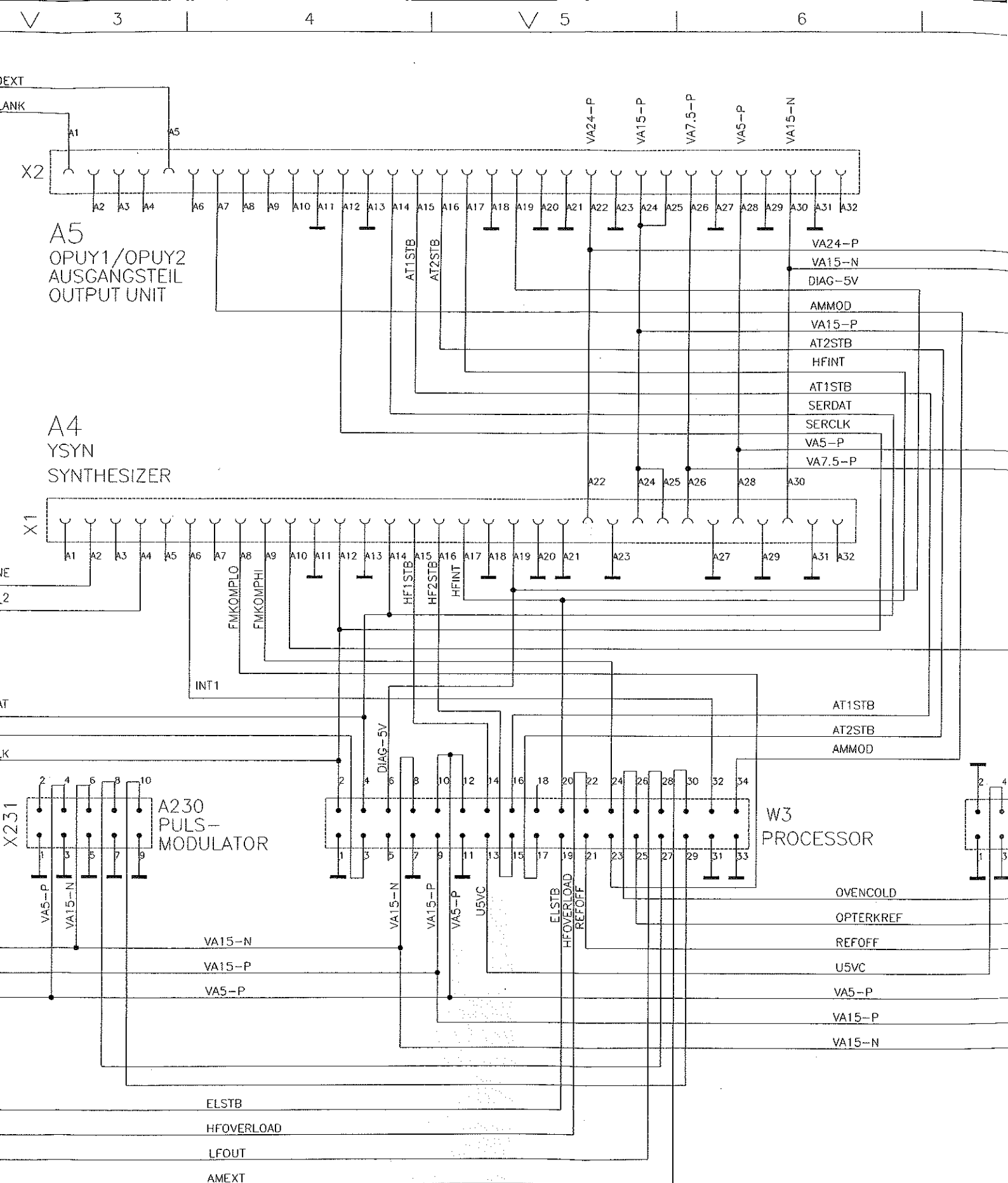

ACHTUNG: ECB !
 ELEKTROSTATISCH GEFÄHRDETE
 BAUELEMENTE ERFORDERN EINE
 BESONDERE HANDHABUNG.
ATTENTION ESD !
 ELECTROSTATIC SENSITIVE DEVICES
 REQUIRE A SPECIAL HANDLING

03		08.04.97	PFL	MENP	DATUM	NAME
				BEARB.		PF
				GEPR.		PF
				NORM		
				PLOTT	18.4.97	PFLUGER
ROHDE & SCHWARZ						
AEND. IND.	AENDERUNGS- MITTEILUNG	DATUM	NAME	ZU GERÄT	SMY	

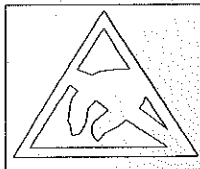
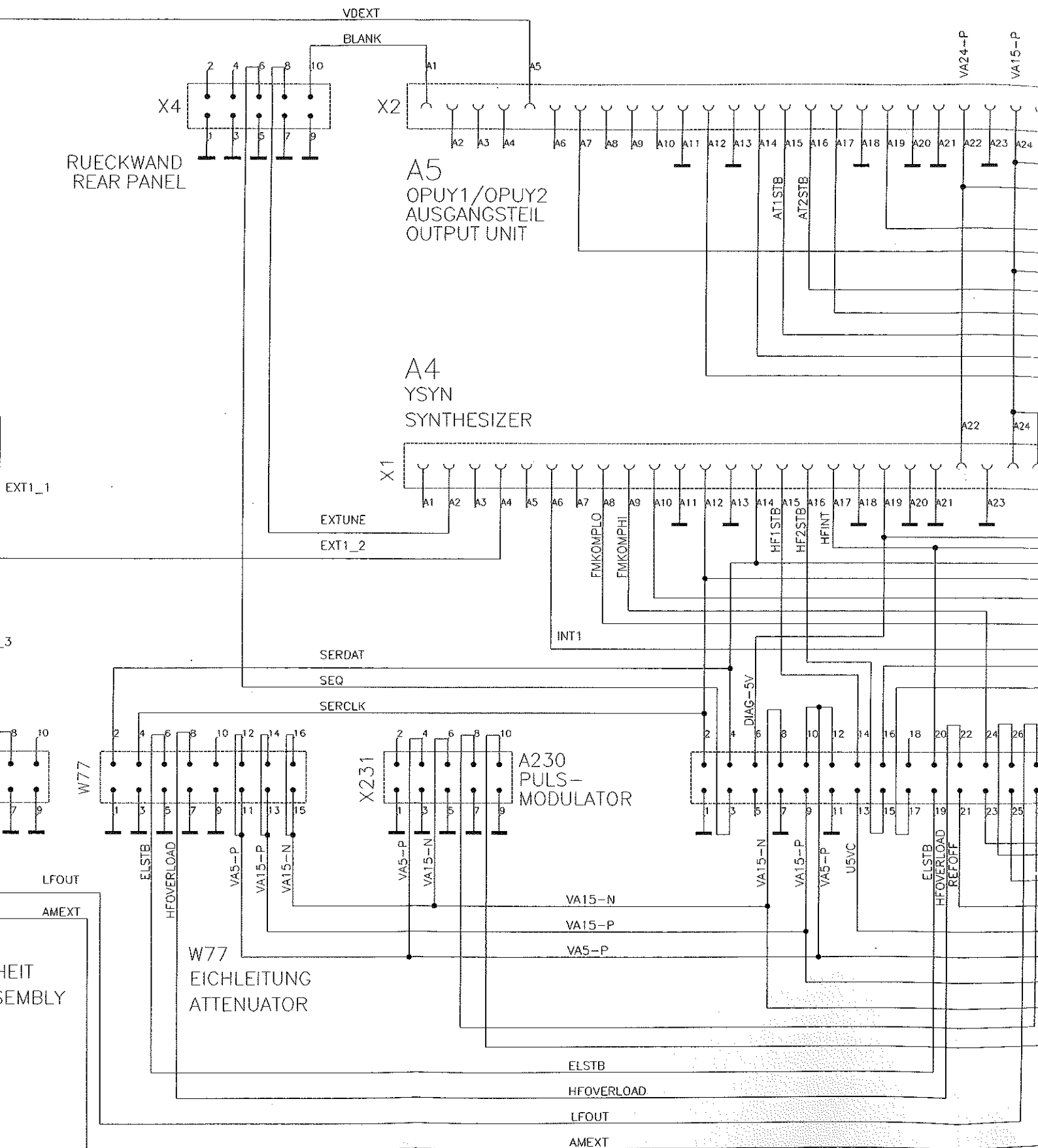

ACHTUNG: EGB
 ELEKTROSTATISCH GEFÄHRDETE
 BAUELEMENTE ERFORDERN EINE
 BESONDERE HANDHABUNG.
 ATTENTION ESD
 ELECTROSTATIC SENSITIVE DEVICES
 REQUIRE A SPECIAL HANDLING.

03	
AEND. IND.	AENDERUNG MITTEILUNG

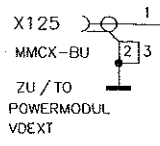

RUECKWAND
REAR PANEL

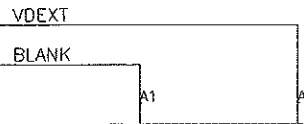
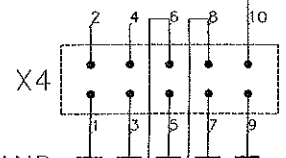

A5
OPUY1/OPUY2
AUSGANGSTEIL
OUTPUT UNIT

A4
YSYN
SYNTHESIZER

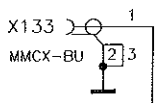
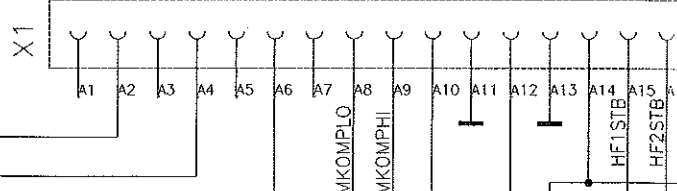

EXT1_1



EXT1_3

EXTUNE

EXT1_2

SERDAT

SEQ

SERCLK

INT1

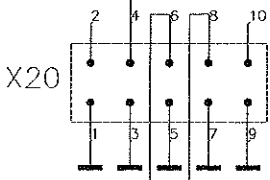

W77

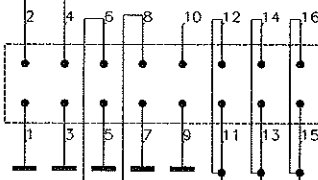

X231

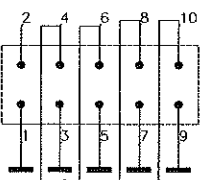

A230
PULS-
MODULATOR

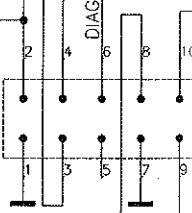

X20
FRONTEINHEIT
FRONT ASSEMBLY

W77
EICHLEITUNG
ATTENUATOR

VA15-N

VA15-P

VA5-P

ELSTB

HFOVERLOAD

LFOUT

AMEXT

BEHALTEN WIR UNS ALLE RECHTE VOR

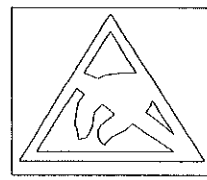

ACHTUNG: EGB !
ELEKTROSTATISCH GEFAEHRDETE
BAUELEMENTE ERFOEDERN EINE
BESONDERE HANDHABUNG
ATTENTION ESD !
ELECTROSTATIC SENSITIVE DEVICES
REQUIRE A SPECIAL HANDLING

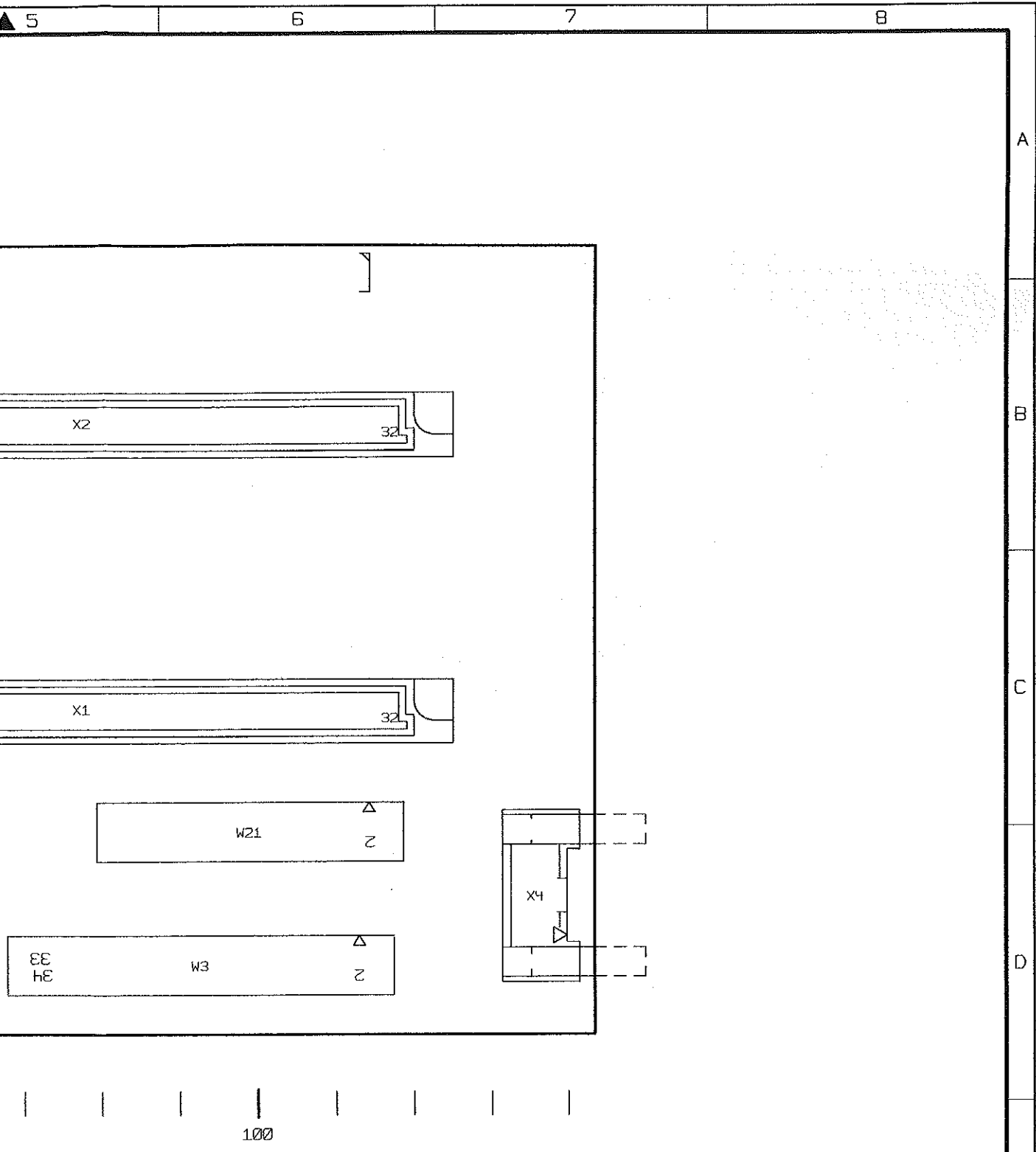

03		07.05.97	PFL	MENP	DATUM	NAME	BENENNUNG	
				BEARB.		PF	MOTHERBOARD	
				GEPR.		PF	MOTHERBOARD	
				NORM				
				PLOTT	07.05.97	PFLUGER		
				ROHDE&SCHWARZ			ZEICHN.-NR.	BLATT-NR.
							1062,6009,01 D	1-
AEND. IND.	AENDERUNGS-MITTEILUNG	DATUM	NAME	ZU GERÄT SMY			REG.I.V. 1062,5502	V. BL.
							ERSTE Z. 1062,5502	

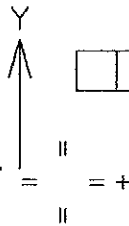
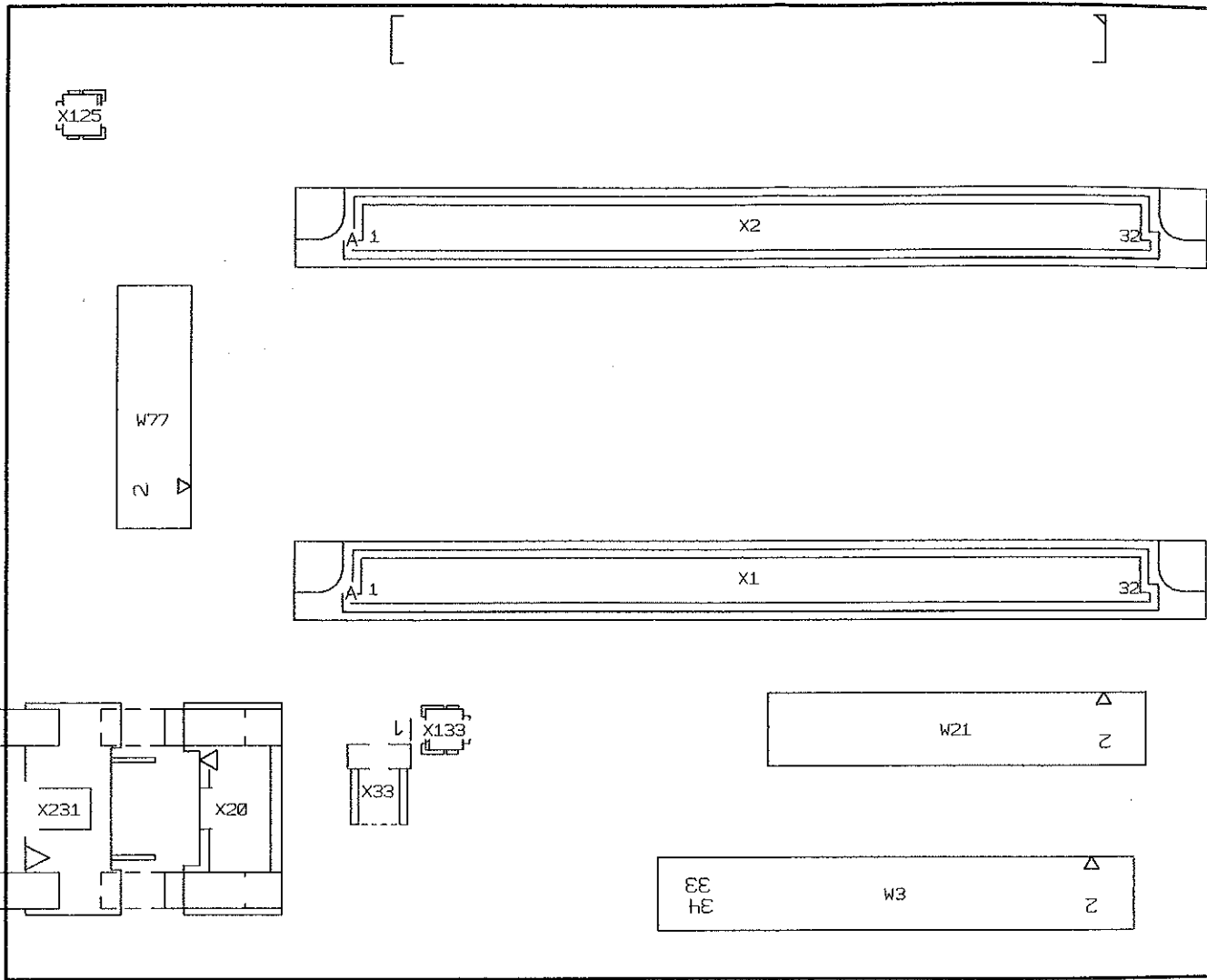

ACHTUNG: EGB!
 ELEKTROSTATISCH GEFÄHRDETE
 BAUELEMENTE ERFORDERN EINE
 BESONDERE HANDHABUNG.
ATTENTION ESD!
 ELECTROSTATIC SENSITIVE DEVICES
 REQUIRE A SPECIAL HANDLING

BINDENDE ANGABEN UEBER VARIANTEN,
 TRIMMWERTE, BAUTEILWERTE UND
 NICHT BESTUECKTE BAUTEILE SIEHE SA.

FOR BINDING INFORMATION ON MODELS,
 TRIMMING AND COMPONENTS VALUES AND
 NONFITTED COMPONENTS SEE PARTS LIST.

03		07.05.97	PFL	MENP	DATUM	
				BEARB.		
				GEPR.		
				NORM		
				PLOTT	07.05.97	PF
AEND. IND.	AENDERUNGS- MITTEILUNG	DATUM	NAME	ROHDE & SCHW		
				ZU GERAET SMY		

1

2

3

4

A

B

C

D

E

F

BEHALTEN WIR UNS ALLE RECHTE VOR
FÜR DIESE UNTERLAGE

100

50

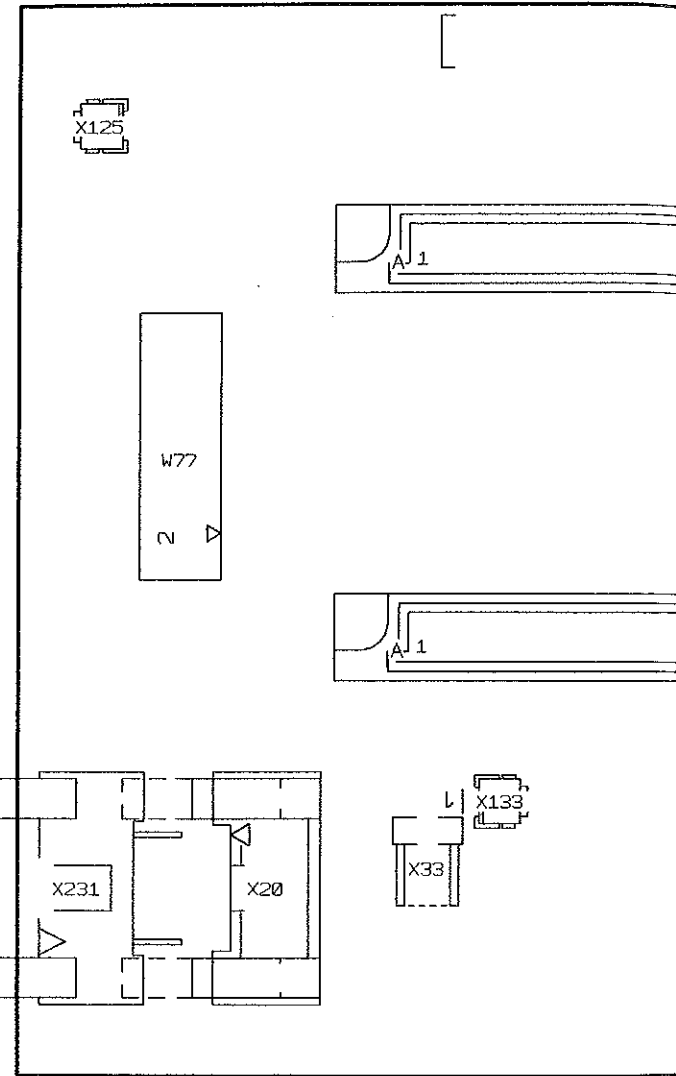
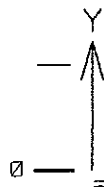

DARSTELLUNG SEITE B
VIEW ON SIDE B

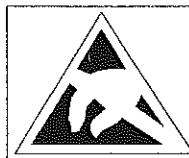

ACHTUNG: EGB!
ELEKTROSTATISCH GEFÄHRDETE
BAUELEMENTE ERFORDERN EINE
BESONDERE HANDLUNG.
ATTENTION ESD!
ELECTROSTATIC SENSITIVE DEVICES
REQUIRE A SPECIAL HANDLING

BINDENDE ANGABEN LIEBER VARIANTEN,
TRIMMWERTE, BAUTEILWERTE UND
NICHT BESTÜECKTE BAUTEILE SIEHE SA.

FOR BINDING INFORMATION ON MODELS,
TRIMMING AND COMPONENTS VALUES AND
NONFITTED COMPONENTS SEE PARTS LIST.

Insert the braided cord (provided only for instruments requiring a high degree of shielding) into the respective groove.

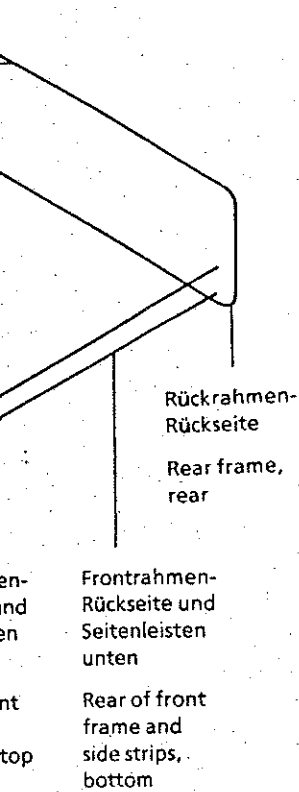

The braided cords in the front of front frame and rear of rear frame must be fixed by glued joints approx. every 80 mm. Make joints (\varnothing approx. 2 mm) on the bottom of the groove and press braided cord firmly on it.

Use a permanently elastic adhesive, such as Si-rubber 3145 RTV (R&S Part No. WV 088.3152).

Instruments with separate rear panels require the individual components to be adjusted to the same level over the complete instrument width.

Top and bottom cover must be fastened by way of the catches on rear frame.

Note that with high rear panel feet (CMS) the catches are concealed; here tighten the rear feet screws only after the top and bottom cover have been securely fitted into the catches.

Öffnen und Schließen des Gehäuses

Die gute Schirmdämpfung der Kompaktbauweise 90 erfordert häufige Kontaktstellen und hohe Paßgenauigkeit. In Verbindung mit einem leichten Anlagedruck, der mit dem Festziehen der Rückwandfußschrauben erreicht wird, erhält man einen straffen Sitz der Ober- und Unterhaube auf dem Rahmen.

Zum **Öffnen** muß man die Rückwandfußverschraubung lösen und die Füße nach rückwärts abziehen (Schrauben bleiben im Fuß haften). Je nach Bedarf läßt sich nun Ober- bzw. Unterhaube ebenfalls nach rückwärts abnehmen. Sitzen die Hauben sehr fest, erleichtert man das Abziehen durch abwechselndes Hebeln in Pfeilrichtung mit einem Schraubenzieher an beiden Geräteseiten (siehe Bild).

Zum **Schließen** des Gehäuses werden erst die Frontkanten der Hauben in die umlaufende Nut des Frontrahmens und der Seitenleisten eingeführt und dann in die Erhöhungen am Rückrahmen bis Anschlag eingerastet. Das Gerät ist wieder geschlossen, wenn die Rückwandfüße eingeschoben und die Schrauben festgezogen sind.

Opening and closing the cabinet

To obtain the high degree of shielding of design 90, many points of contact and accurate fitting are employed. When exerting a slight pressure by tightening the rear-panel feet, tight fitting of the top and bottom covers is ensured.

To **open** the cabinet, first undo the rear panel feet screws and withdraw the feet (captive screws). It is now possible to detach top and bottom cover if required. If the fitting of these cover plates is very tight, removal can be facilitated by alternately levering on both sides of the instrument using a screwdriver (see illustration).

To **close** the cabinet, insert the front edges of the covers into the groove of the front frame and the side strips and lock them into the catches on the rear frame into detent position. The cabinet is closed when the rear-panel feet are inserted and the screws tightened.

Nut im Frontrahmen
Groove in front frame

Ober- und Unterhaube werden durch die Rückwandfußverschraubung befestigt.

Top and bottom covers are fixed by screwing feet to rear panel

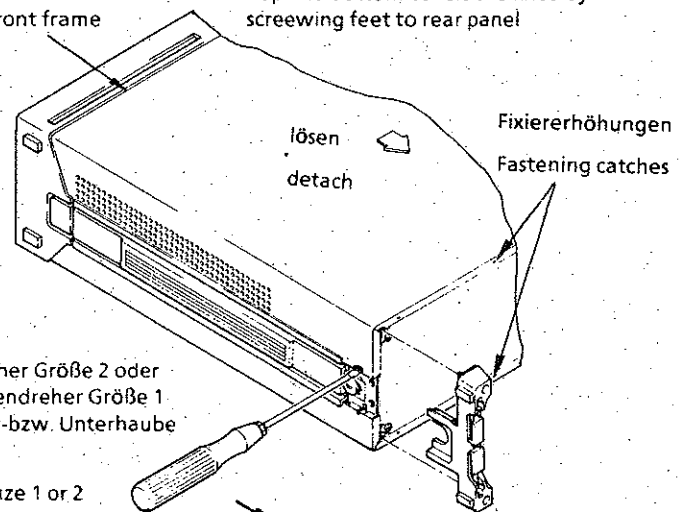

ing

struction

onstruction consists of a self-mounting aluminium-cast frame front, mounting and rear top and bottom covers (see drawing).

and panelling:

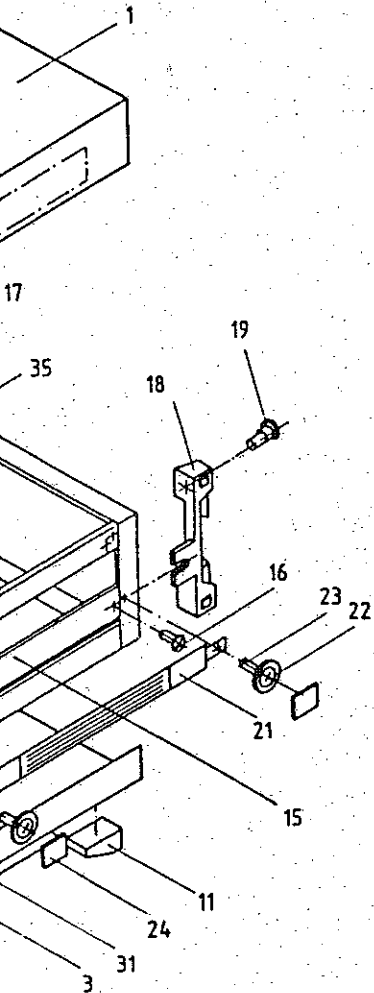

Dichtschnur (nur bei Geräten mit erhöhtem Schirmdämpfungsbedarf vorhanden) jeweils in die umlaufende Nut einlegen.

Insert the braided cord (provided only for instruments requiring a high degree of shielding) into the respective groove.

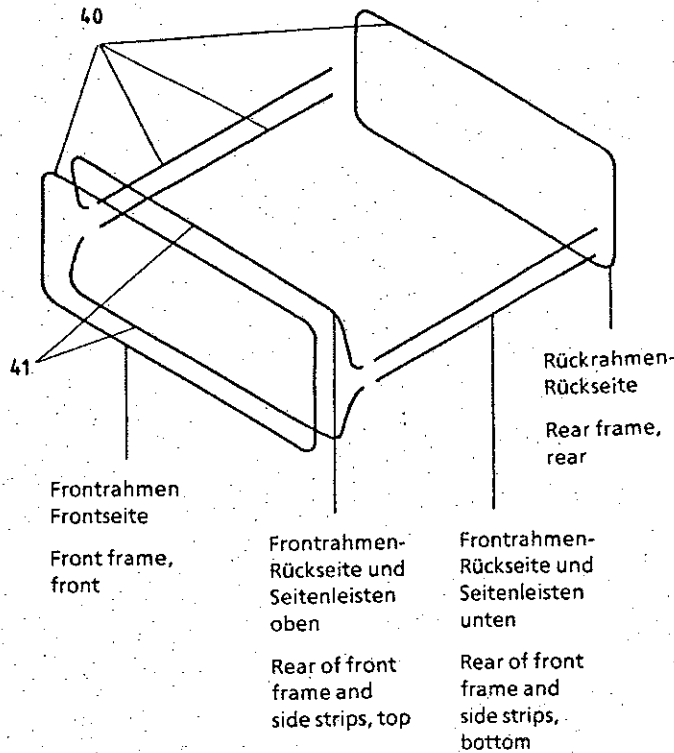

Die Dichtschnüre in der Frontrahmen-Frontseite und in der Rückrahmen-Rückseite müssen durch Klebepunkte in Abständen von ca. 80 mm fixiert werden. Dazu Klebepunkte mit ca. $\varnothing 2$ mm im Nutgrund anbringen und Dichtschnur aufdrücken.

The braided cords in the front of front frame and rear of rear frame must be fixed by glued joints approx. every 80 mm. Make joints (\varnothing approx. 2 mm) on the bottom of the groove and press braided cord firmly on it.

Dauerhaft elastischen Kleber wie z.B. Si-Kautschuk 3145 RTV (R&S-Sachnr. WV 088.3152) verwenden.

Use a permanently elastic adhesive, such as Si-rubber 3145 RTV (R&S Part No. WV 088.3152).

Bei Geräten mit geteilten Rückplatten müssen beim Zusammenbau die Einzelelemente über die gesamte Gehäusebreite waagrecht zueinander ausgerichtet werden.

Instruments with separate rear panels require the individual components to be adjusted to the same level over the complete instrument width.

Ober- und Unterhaube müssen mit den Erhöhungen am Rückrahmen fixiert sein.

Top and bottom cover must be fastened by way of the catches on rear frame.

Achtung: bei hohen Rückwandfüßen (CMS) werden die Fixier-Erhöhungen verdeckt, hier Rückwandfüße erst anschrauben, wenn die Ober- u. Unterkante sicher in den Erhöhungen am Rückrahmen fixiert sind.

Note that with high rear panel feet (CMS) the catches are concealed; here tighten the rear feet screws only after the top and bottom cover have been securely fitted into the catches.

Öffnen u des Gehä

Die gute Sch... Kompaktbauv... häufige Konta... Paßgenauigke... mit einem lei... der mit dem... wandfußschra... erhält man ein... Ober- und Un... Rahmen.

Zum Öffnen... wandfußversch... die Füße nach... (Schrauben... haften). Je na... nun Ober- bzw... falls nach rü... Sitzen die Ha... leichtert man... abwechselnde... richtung mit... zieher an b... (siehe Bild).

Zum Schließ... werden erst d... Hauben in die... Frontrahmens... leisten eingefü... Erhöhungen a... Anschlag eing... wieder gesch... Rückwandfüß... die Schrauben...

Nut i... Groo...

Schlitzschraub... Kreuzschlitzsch... oder 2 in Nut i...

Screwdriver siz... Phillips screwd... in groove in to...

Gehäuse

Aufbau

Der Aufbau besteht aus einer tragenden Aluminium-Druckguß-Rahmenkonstruktion mit gerätespezifischer Front-, Montage- und Rückplatte, die mit einer Ober- und Unterhaube (= Beplankung) ummantelt ist.

Rahmen und Beplankung:

Casing

Construction

The construction consists of a self-supporting aluminium-cast frame with front, mounting and rear panel, top and bottom covers (= panelling).

Frame and panelling:

Dichtschnur (nur bei Geräten mit erhöhtem Schirmdämpfungsbedarf vorhanden) jeweils in die umlaufende Nut einlegen.

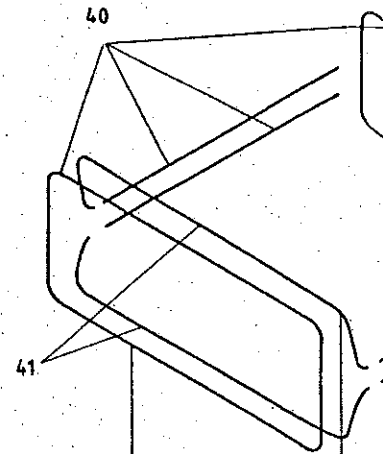
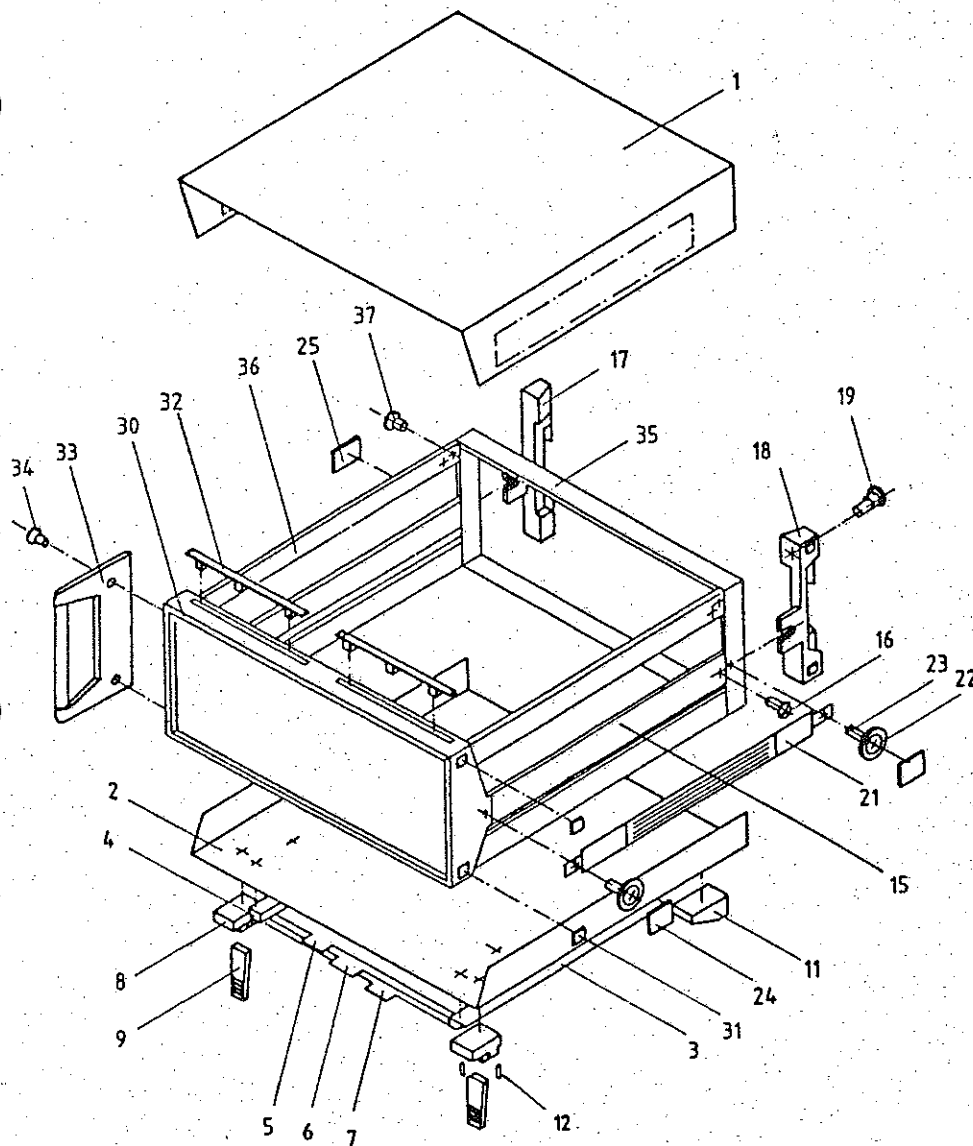

Frontrahmen Frontseite

Front frame, front

Frontrahmen Rückseite u. Seitenleiste oben

Rear of front frame and side strips, top

Die Dichtschnüre in der Frontrahmen-Frontseite und in der Rückrahmen-Rückseite müssen durch Klebepunkte in Abständen von ca. 80 mm fixiert werden. Dazu Klebepunkte mit ca. $\varnothing 2$ mm im Nutgrund anbringen und Dichtschnur aufdrücken.

Dauerhaft elastischen Kleber wie z.B. Si-Kautschuk 3145 RTV (R&S-Sachnr. WV 088.3152) verwenden.

Bei Geräten mit geteilten Rückplatten müssen beim Zusammenbau die Einzelelemente über die gesamte Gehäusebreite waagrecht zueinander ausgerichtet werden.

Ober- und Unterhaube müssen mit den Erhöhungen am Rückrahmen fixiert sein.

Achtung: bei hohen Rückwandfüßen (CMS) werden die Fixier-Erhöhungen verdeckt, hier Rückwandfüße erst anschrauben, wenn die Ober- u. Unterkante sicher in den Erhöhungen am Rückrahmen fixiert sind.



ROHDE & SCHWARZ

SERVICEUNTERLAGEN

RECHNER

1062.6309.01

Inhaltsverzeichnis

7 Prüfen und Instandsetzen der Baugruppe	5
7.1 Funktionsbeschreibung	5
7.1.2 Prozessorteil.....	5
7.1.2.1 CPU mit Peripherie.....	5
7.1.2.2 Tastaturmatrix.....	5
7.1.2.3 IEC-Interface.....	5
7.1.3 Analogteil.....	5
7.1.3.1 NF-Synthesizer.....	6
7.1.3.2 AM-Modulationszweig.....	6
7.2 Meßgeräte und Hilfsmittel	6
7.3 Fehlersuche	6
7.4 Prüfen und Abgleich	7
7.4.1 Prüfen der Stromversorgung.....	7
7.4.2 Einstellen der Power Fail Schwelle.....	7
7.4.3 Einstellen der Referenzspannung.....	7
7.4.4 Abgleich des AM-EXT Spannungskomparators.....	7
7.4.5 Pegel INT1 Abgleich.....	7
7.4.6 INT1 DC-Offset 0V-Abgleich.....	7
7.4.7 Test der Diagnoseeingänge.....	7
7.4.8 Prüfen des Tastatur-Interrupt.....	8
7.4.9 Prüfen der RAM-Pufferspannung.....	8
7.4.10 Prüfen der Frequenzgenauigkeit.....	8
7.4.11 Pegelgenauigkeit prüfen.....	8
7.4.11.1 Frequenzgang.....	8
7.4.11.2 Einstellfehler.....	8
7.4.11.3 INT1 DC-Offset.....	9
7.4.12 Prüfen der spektralen Reinheit.....	9
7.4.12.1 Klirrfaktor prüfen.....	9
7.4.12.2 Harmonische und Nichtharmonische Störsignale prüfen.....	9
7.4.13 Prüfung der Umschaltung des AM-Ausgangs.....	9
7.4.14 Prüfen des Spannungskomparators für AM-EXT.....	9
7.5 Zerlegung und Zusammenbau	10
7.6 Externe Schnittstellen	10

Schaltteilliste
Koordinatenliste
Stromlauf
Bestückungsplan

7.1 Funktionsbeschreibung

Die Schaltung der Baugruppe Rechner gliedert sich in einen Prozessor- und einen Analogteil.

7.1.2 Prozessorteil

7.1.2.1 CPU mit Peripherie

Der Prozessor ist die Steuereinheit für das gesamte Gerät. Der Kernbaustein ist die CPU N80C196 (D10) mit den Programmspeicher EPROM D206, EEPROM D125 und den batteriegepufferten RAM D210.

Die beiden je 8-Bit Ports P3 und P4 der CPU stellen den Adress-/Datenbus dar. PAL D110 wird als Ausgabeport für den Strobe verwendet. Analoge Spannungen im Bereich 0V...±5V (X3.6) werden dem internen A/D-Wandler der CPU über Port P0.0 zugeführt. Die abgleichbare 5.12V Referenzspannung des D/A-Wandlers wird mit der Spannungsreferenz REF02 (D107) erzeugt.

Am Eingabeport P1 werden die logischen Zustände der Interrupt-Leitungen erkannt. P1.3 dient zum Erkennen der Option Referenzoszillator. Bei Netzspannungseinbrüchen, Netzausfällen sowie bei Ein- bzw. Ausschalten des Gerätes liefert die Reset-Schaltung D100 ein definiertes Reset-Signal für die CPU. Weitere Adreßsignale für RAM, EPROM, EEPROM und IEC-Bus werden mit PAL D110 dekodiert.

7.1.2.2 Tastaturmatrix

Von der Tastaturmatrix der Anzeige-Tastatur-Baugruppe gelangen 8 Spalten- und 5 Zeilenleitungen (COL0...COL7, ROW1...ROW5) auf die Baugruppe. Ist keine Taste gedrückt, so liegen ROW1...ROW5 auf HIGH-Potential. COL0...COL7 werden durch D303 auf LOW gehalten.

Ein Tastendruck verbindet nun eine Zeilen- mit einer Spaltenleitung, wodurch die Zeilenleitung auf LOW gesetzt wird. Der entsprechende Kondensator wird dabei entladen. Über D302 wird verzögert mit D305 wegen Tastenprellens, ein Interrupt (KEYINT) erzeugt. Beim Auslesen des Tastencodes wird D303 hochohmig, so daß alle Spaltenleitungen, welche nicht über die geschlossene Taste verbunden sind, schnell HIGH-Potential annehmen. Der entladene Kondensator stellt nun sicher, daß die entsprechende Spaltenleitung während der Zugriffszeit auf LOW gehalten wird.

7.1.2.3 IEC-Interface

Das IEC-Bus-Interface, bestehend aus dem integrierten IEC-Bus Baustein D250 und den beiden Bausteinen D260, D255 implementiert die nach IEEE-Standard 488-1978 definierte Schnittstelle. Das Handshake bei einem Datentransfer wickelt der Baustein selbstständig ab. Der bei einer Statusänderung generierte Interrupt gelangt an den HAI 0 Pin der CPU.

7.1.3 Analogteil

Der Analogteil der Baugruppe Rechner stellt die für den AM- und FM-Betrieb benötigten Modulationsignale bereit. Er besteht aus einem NF-Synthesizer und dem AM-Modulationszweig.

7.1.3.1 NF-Synthesizer

Mit direkter digitaler Synthese wird die Ausgangsfrequenz des Modulationsgenerators erzeugt.

Das Kernstück des Synthesizers ist der DDS-Baustein D420 der einen 32-Bit-Addierer, zwei 32-Bit-Inkrementenspeicher, Sinus-ROM und eine Schnittstelle für die serielle Datenübertragung enthält. Im Addierer wird ein Inkrement zyklisch mit einer Taktfrequenz von 2.147484 MHz aufaddiert. Der Takt kommt von dem Quarzoszillator B401. Die höhenwertigen 13-Bit der Summe steuern die Adressen des Sinus-ROM. In diesem sind die Amplitudenwerte einer Periode der Sinusschwingung gespeichert.

Die höhenwertigen 12-Bit der Amplitudenwerte einer Sinusschwingung gelangen an einen D/A-Wandler der ein treppenförmiges Signal liefert. Die zwei 6-Bit D-Register (D430 und D440) unterdrücken die verschiedenen Laufzeiten aus dem Sinus-ROM des DDS-Bausteines.

Ein Sample & Hold Schalter unterdrückt die Einschwingvorgänge des D/A-Wandlers. Ein nachgeschaltete 600kHz Tiefpaß sorgt für ausreichende Unterdrückung der Taktfrequenz. Die SinX/X Kompensation ist durch R491 und C490 realisiert.

7.1.3.2 AM-Modulationszweig

Mit dem Analogschalter D500, D510 und D550 wird die Auswahl des AM-Signals zwischen intern und extern getroffen. Der dem Eingang parallel geschaltete Fensterdiskriminator (N544) überwacht die Amplitude des externen Modulationssignals und liefert bei Unter- oder Überschreitung dem Prozessor D10 das AMKOMLO- oder AMKOMHI-Signal.

7.2 Meßgeräte und Hilfsmittel

- Digitalmultimeter (z.B. R&S UDS5)
- DC-Spannungsquelle (z.B. R&S NGT)
- Audio Analyzer (z.B. R&S UPA)
- Frequenzgenerator (z.B. R&S SPN)
- RMS-Voltmeter (z.B. R&S URE3)
- Spektrum-Analyzer (z.B. R&S FSA)
- Oszilloskop
- Frequenzzähler

7.3 Fehlersuche

Kein Signal an LFOUT (X3.23)	Taktgenerator an X401 prüfen Signal an P405 prüfen S&H-Schaltung an P409 prüfen Tiefpaßfilter und Verstärker N520 an P530 prüfen
AM-INT an AMMOD (X3.34) fehlerhaft	Schalter D510 und D550 sowie Verstärker N530 prüfen
AM-EXT an AMMOD (X3.34) fehlerhaft	Schalter D500 und D550 und Verstärker N530 prüfen

7.4 Prüfen und Abgleich

Alle Meßwerte ohne Toleranzangabe sind als Richtwerte zu verstehen. Spannungen ohne weitere Bezeichnungen bedeuten DC-Spannungen.

7.4.1 Prüfen der Stromversorgung

- Ein Amperemeter in die Versorgungsleitungen der einzelnen Versorgungsspannungen einschleifen.
- _ Die Stromaufnahme der Baugruppe überprüfen. Die Sollwerte zu den jeweiligen Versorgungsspannungen sind unter "Externe Schnittstellen" zu finden.

7.4.2 Einstellen der Power Fail Schwelle

- Die Netzspannung so einstellen, daß an X3.13 (U5VC) 7.1V \pm 0.1V anliegen.
- _ R139 so einstellen, daß an D100.10 gerade ein Wechsel des Logikpegels (H zu L bzw. L zu H) stattfindet.

7.4.3 Einstellen der Referenzspannung

- _ Mit R102 DC-Spannung an Meßpunkt P101 auf +5.12V \pm 1mV einstellen.

7.4.4 Abgleich des AM-EXT Spannungskomparators

- _ Mit dem Pot R550 am Meßpunkt P513 eine Spannung von -1.02V \pm 1mV einstellen.

7.4.5 Pegel INT1 Abgleich

- Einstellung: 1kHz
- Kalibriertes AC-Voltmeter an INT1 (X3.32) anschließen.
- _ Mit R450 Ausgangsamplitude am AC-Voltmeter auf 0.7071Veff abgleichen.

7.4.6 INT1 DC-Offset 0V-Abgleich

- Einstellung: AF 1kHz
- DC-Voltmeter an INT1 (X3.32) anschließen.
- _ Mit R520 DC-Offset auf Minimum abgleichen.

7.4.7 Test der Diagnoseeingänge

- An Meßpunkt P100 ein DC-Voltmeter anschließen.
- Einstellung: SPEC 109
SPEC 40 (GAIN16 D105.5 LOW).
- _ Die gemessene Spannung muß +2.56V \pm 20mV betragen.
- Einstellung: SPEC 39 (GAIN16 D105.5 HIGH).
- _ Die gemessene Spannung muß +2.56V \pm 50mV betragen.

- Einstellung: RF 1GHz
SPEC 40 (GAIN16 D105.5 LOW).
SPEC 115
- _ Die Spannung an X3.6 messen.
- _ Die Spannung an P100 muß +2.56V minus die halbe Spannung an X3.6 $\pm 20\text{mV}$ betragen.

- Einstellung: SPEC 39 (GAIN16 D105.5 HIGH).
- _ Die Spannung an X3.6 messen.
- _ Die Spannung an P100 muß +2.56V minus sechzehn mal die halbe Spannung an X3.6 $\pm 100\text{mV}$ betragen.

7.4.8 Prüfen des Tastatur-Interrupt

- Ein Oszilloskop an P305 anschließen. Eine beliebige Taste drücken.
- _ Am Oszilloskop muß ein LOW-Puls mit ca. 2.5ms Pulsdauer meßbar sein.

7.4.9 Prüfen der RAM-Pufferspannung

- _ Batteriespannung direkt an den Batterieanschlüssen messen.
- Versorgungsspannungen abschalten.
- _ An D210.28 soll die gemessene Batteriespannung (Tol. -10mV) anliegen.

7.4.10 Prüfen der Frequenzgenauigkeit

- Einstellung: AF 100kHz
- Kalibrierten Frequenzzähler an AF INT anschließen.
- _ Frequenz messen. Max. Fehler $\pm 10\text{Hz}$.

7.4.11 Pegelgenauigkeit prüfen

7.4.11.1 Frequenzgang

- Einstellung: AF zwischen 10Hz...500kHz variieren.
- Kalibriertes AC-Voltmeter an AF INT anschließen.
- _ Pegel messen und mit der Tabelle vergleichen.
Frequenzgang von 10Hz

bis 50kHz	<0.2dB
bis 100kHz	<0.3dB
bis 500kHz	<0.5dB

7.4.11.2 Einstellfehler

- Einstellung: AF 1kHz
AM INT EIN
- Kalibriertes AC-Voltmeter an AF INT, INT1 (X3.32) und AMMOD (X3.34) Ausgänge anschließen.

_ Ausgangssignale prüfen.

AF INT 0.7071Veff

INT1 0.7071Veff (X3.32)

AMMOD 0.7071Veff(X3.34) Max. Fehler ±1%

7.4.11.3 INT1 DC-Offset

• DC-Voltmeter an INT1 (X3.32) anschließen.

_ DC-Spannung muß <±5mV sein.

7.4.12 Prüfen der spektralen Reinheit

7.4.12.1 Klirrfaktor prüfen

• Einstellung: AF zwischen 20 Hz und 100 kHz variieren.

• Klirrfaktormesser an AFOUT anschließen.

_ Klirrfaktor bei verschiedenen Frequenzen messen.

Klirrfaktor muß <0.1% sein.

7.4.12.2 Harmonische und Nichtharmonische Störsignale prüfen

• Einstellung: AF zwischen 100kHz und 500kHz variieren.

• Spektrum-Analyzer an AFOUT ($R_i = 1M\Omega$) anschließen.

_ Oberwellen und Nebenwellenabstand muß < -40dBc sein.

7.4.13 Prüfung der Umschaltung des AM-Ausgangs

• Einstellung: AF 10kHz

AM INT ON

• Oszilloskop an AMMOD (X3.34) anschließen.

_ Am Oszilloskop muß ein 10 kHz Sinussignal zu sehen sein.

• Einstellung: AM EXT AC

• Kurzschlußbrücke X501 zwischen X501.1 und X501.2

• NF-Generator an AM EXT anschließen.

• Einstellung NF-Generator: Frequenz 1kHz

Spannung 0.7071Veff

_ AMMOD (X3.34) Signal prüfen. Es soll 0.7071Veff anstehen.

Max. Fehler ±1%

7.4.14 Prüfen des Spannungskomparators für AM-EXT

• Einstellung: AM EXT DC ON

• NF-Generator an AM EXT anschließen.

• Einstellung NF-Generator: Frequenz 1kHz

Spannung 0.7071Veff

_ Die beiden Ausgänge D545.13 und D545.12 müssen LOW sein.

• Pegel auf 0.735Veff erhöhen.

_ Ausgangspegel an D545.13 muß HIGH sein.

• Pegel auf 0.680Veff einstellen.

_ Pegel an D545.12 muß HIGH sein.

7.5

Zerlegung und Zusammenbau

Nach Öffnen des Gerätes und Lösen der Schrauben kann die Baugruppe aus ihrem Steckplatz entnommen werden. Nach dem Lösen der Schrauben der Schirmdeckel ist die Baugruppe an beiden Seiten zugänglich.

Der Einbau der Baugruppe und Zusammenbau des Gerätes erfolgt entsprechend in umgekehrter Reihenfolge.

7.6

Externe Schnittstellen

Pin	Name	Ein/Ausgang	Herkunft/Ziel	Wertebereich	Signalbeschreibung
X1.1	VA5-P	Ausgang	A1 FRONT X1.1	+4.9V...+5.3V max.340mA	+5V Versorgungsspannung
X1.2	SERCLK	Ausgang	A1 FRONT X1.2	HCMOS-Pegel	Seriell-Clock
X1.3	VA5-P	Ausgang	A1 FRONT X1.3	+4.9V...+5.3V max.340mA	+5V Versorgungsspannung
X1.4	SERDATA	Ausgang	A1 FRONT X1.4	HCMOS-Pegel	Seriell-Data
X1.6	DIS1STB#	Ausgang	A1 FRONT X1.6	HCMOS-Pegel	Display Strobe 1
X1.8	DIS2STB#	Ausgang	A1 FRONT X1.8	HCMOS-Pegel	Display Strobe 2
X1.10	LEDSTB	Ausgang	A1 FRONT X1.10	HCMOS-Pegel	LED-Strobe
X1.11	COL7	Eingang	A1 FRONT X1.11	HCMOS-Pegel	Tasten-Code
X1.12	C/D#	Ausgang	A1 FRONT X1.12	HCMOS-Pegel	
X1.13	COL6	Eingang	A1 FRONT X1.13	HCMOS-Pegel	Tasten-Code
X1.14	DISBUSY	Eingang	A1 FRONT X1.14	HCMOS-Pegel	Steuerleitung
X1.15	COL5	Eingang	A1 FRONT X1.15	HCMOS-Pegel	Tasten-Code
X1.16	RES#	Ausgang	A1 FRONT X1.16	HCMOS-Pegel	Reset
X1.17	COL4	Eingang	A1 FRONT X1.17	HCMOS-Pegel	Tasten-Code
X1.18	ROW5	Eingang	A1 FRONT X1.18	HCMOS-Pegel	Tasten-Code
X1.19	COL3	Eingang	A1 FRONT X1.19	HCMOS-Pegel	Tasten-Code
X1.20	ROW4	Eingang	A1 FRONT X1.20	HCMOS-Pegel	Tasten-Code
X1.21	COL2	Eingang	A1 FRONT X1.21	HCMOS-Pegel	Tasten-Code
X1.22	ROW3	Eingang	A1 FRONT X1.22	HCMOS-Pegel	Tasten-Code
X1.23	COL1	Eingang	A1 FRONT X1.23	HCMOS-Pegel	Tasten-Code
X1.24	ROW2	Eingang	A1 FRONT X1.24	HCMOS-Pegel	Tasten-Code
X1.25	COL0	Eingang	A1 FRONT X1.25	HCMOS-Pegel	Tasten-Code
X1.26	ROW1	Eingang	A1 FRONT X1.26	HCMOS-Pegel	Tasten-Code
X2.6	ATN	Bidir.	IEC-Bus	HCMOS-Pegel	Steuerleitung
X2.8	SRQ	Bidir.	IEC-Bus	HCMOS-Pegel	Steuerleitung
X2.10	IFC	Bidir.	IEC-Bus	HCMOS-Pegel	Steuerleitung
X2.12	NDAC	Bidir.	IEC-Bus	HCMOS-Pegel	Steuerleitung
X2.14	NFRD	Bidir.	IEC-Bus	HCMOS-Pegel	Steuerleitung
X2.16	DAV	Bidir.	IEC-Bus	HCMOS-Pegel	Steuerleitung
X2.17	REN	Bidir.	IEC-Bus	HCMOS-Pegel	Steuerleitung
X2.18	EOI	Bidir.	IEC-Bus	HCMOS-Pegel	Steuerleitung
X2.19	DIO8	Bidir.	IEC-Bus	HCMOS-Pegel	Data-Bus
X2.20	DIO4	Bidir.	IEC-Bus	HCMOS-Pegel	Data-Bus
X2.21	DIO7	Bidir.	IEC-Bus	HCMOS-Pegel	Data-Bus
X2.22	DIO3	Bidir.	IEC-Bus	HCMOS-Pegel	Data-Bus
X2.23	DIO6	Bidir.	IEC-Bus	HCMOS-Pegel	Data-Bus
X2.24	DIO2	Bidir.	IEC-Bus	HCMOS-Pegel	Data-Bus

Pin	Name	Ein/Ausgang	Herkunft/Ziel	Wertebereich	Signalbeschreibung
X2.25	DIO5	Bidir.	IEC-Bus	HCMOS-Pegel	Data-Bus
X2.26	DIO1	Bidir.	IEC-Bus	HCMOS-Pegel	Data-Bus
X3.2	SERCLK	Ausgang	A3 MBRD X3.2	HCMOS-Pegel	Seriell-Clock
X3.3	SEQ	Eingang	A3 MBRD X3.3	HCMOS-Pegel	Sequenz
X3.4	SERDATA	Ausgang	A3 MBRD X3.4	HCMOS-Pegel	Seriell-Data
X3.5	frei				
X3.6	DIAG-5V	Eingang	A3 MBRD X3.6	-5V...+5V	Diagnose/Kalibrierung
X3.8	VA15-N	Eingang	A3 MBRD X3.8	-15.5V...-14.4V max. 75mA	-15V Versorgungsspannung
X3.9	VA15-P	Eingang	A3 MBRD X3.9	+14.4V...+15.6V max. 65mA	+15V Versorgungsspannung
X3.10	VA5-P	Eingang	A3 MBRD X3.10	+4.9V...5.3V max. 340mA	+5V Versorgungsspannung
X3.12	VA5-P	Eingang	A3 Motherb. X3.12	+4.9V...5.3V max. 340mA	+5V Versorgungsspannung
X3.13	USVC	Eingang	A3 MBRD X3.13	+7.2V...+7.8V	Überspannung für Reset
X3.14	HF1STB	Ausgang	A3 MBRD X3.14	HCMOS-Pegel	Strobe 1 Synthesizer
X3.15	HF2STB	Ausgang	A3 MBRD X3.15	HCMOS-Pegel	Strobe 2 Synthesizer
X3.16	AT1STB	Ausgang	A3 MBRD X3.16	HCMOS-Pegel	Strobe 1 Ausgangsverstärker
X3.17	AT2STB	Ausgang	A3 MBRD X3.17	HCMOS-Pegel	Strobe 2 Ausgangsverstärker
X3.18	AT3STB	Ausgang	A3 MBRD X3.18	HCMOS-Pegel	Strobe 3 Ausgangsverstärker
X3.19	ELSTB	Ausgang	A3 MBRD X3.19	HCMOS-Pegel	Strobe Eichleitung
X3.20	HFINT	Eingang	A3 MBRD X3.20	HCMOS-Pegel	Interrupt
X3.21	REFOFF	Ausgang	A3 MBRD X3.21	HCMOS-Pegel	Option Ein/Aus
X3.22	HFOVERLOAD	Eingang	A3 MBRD X3.22	HCMOS-Pegel	Overload HF
X3.23	FMKOMLO	Eingang	A3 MBRD X3.23	HCMOS-Pegel	FM EXT zu klein
X3.24	FMKOMHI	Eingang	A3 MBRD X3.24	HCMOS-Pegel	FM EXT zu groß
X3.25	OPTERKREF	Eingang	A3 MBRD X3.25	HCMOS-Pegel	Optionserkennung Ref. Oszi.
X3.26	OVENCOLD	Eingang	A3 MBRD X3.26	HCMOS-Pegel	Thermostat Option
X3.28	LFOUT	Ausgang	A3 MBRD X3.28	1VS	Modulationsgenerator
X3.30	AMEXT	Eingang	A3 MBRD X3.30	1VS	Ext. Eingang AM
X3.32	INT1	Ausgang	A3 MBRD X3.32	1VS	Int FM Ausgang
X3.34	AMMOD	Ausgang	A3 MBRD X3.34	1VS	AM Mod. Ausgang
X1.5/7/9				GND	
X2.1/2/3/4				GND	
5/7/9/11				GND	
13/15/				GND	
X3.1/7/11				GND	
27/29/31/33				GND	



ROHDE & SCHWARZ

SERVICE INSTRUCTIONS

Controller

1062.6309.01

Contents

7 Testing and Repair of the Module.....	5
7.1 Function Description.....	5
7.1.2 Processor Section.....	5
7.1.2.1 CPU with Peripherals	5
7.1.2.2 Keyboard Matrix	5
7.1.2.3 IEC/IEEE Interface	5
7.1.3 Analog Section.....	5
7.1.3.1 AF Synthesizer.....	6
7.1.3.2 AM-Modulation Path.....	6
7.2 Test Instruments and Utilities.....	6
7.3 Troubleshooting.....	6
7.4 Testing and Adjustment.....	7
7.4.1 Testing the Power Supply.....	7
7.4.2 Setting the Power-Fail Threshold.....	7
7.4.3 Setting the Reference Voltage.....	7
7.4.4 Adjustment of the AM-EXT Voltage Comparator.....	7
7.4.5 Adjusting Level INT1.....	7
7.4.6 0V-Adjustment of INT1 DC Offset.....	7
7.4.7 Testing the Diagnosis Inputs.....	7
7.4.8 Testing the Keyboard Interrupt.....	8
7.4.9 Testing the RAM Backup Voltage.....	8
7.4.10 Testing the Frequency Accuracy.....	8
7.4.11 Testing Level Accuracy.....	8
7.4.11.1 Frequency Response.....	8
7.4.11.1 Setting Errors.....	8
7.4.11.3 INT1 DC-Offset.....	9
7.4.12 Testing the Spectral Purity.....	9
7.4.12.1 Testing Distortion.....	9
7.4.12.2 Testing Harmonic and Nonharmonic Spuriae....	9
7.4.13 Testing the AM Output Switchover.....	9
7.4.14 Testing the Voltage Comparator for AM-EXT.....	9
7.5 Disassembly and Assembly.....	10
7.6 External Interfaces.....	10

Parts list
List of coordinates
Circuit diagram
Component layout diagram

7.1 Function Description

The circuit of the controller module consists of a processor section and an analog section.

7.1.2 Processor Section7.1.2.1 CPU with Peripherals

The processor is the control unit for the overall instrument. The CPU N80C196 (D10) in conjunction with the program memories EPROM D206, EEPROM D125 and the battery-backed RAM D210 forms the nucleus.

The two 8-bit ports P3 and P4 of the CPU represent the address/data bus. PAL D110 is used as output port for the strobe. Analog voltages in the range from 0V to $\pm 5V$ (X3.6) are applied to the internal A/D converter of the CPU via the port P0.0. The adjustable 5.12V reference voltage of the D/A converter is generated by means of the voltage reference REF02 (D107). The logic states of the interrupt lines are identified at the input port P1. P1.3 is used to identify the reference oscillator option. The reset circuit D100 provides a defined reset signal for the CPU in case of dips or failures of the ac supply voltage as well as with instrument switch-on or switch-off. PAL D110 decodes further address signals for RAM, EPROM, EEPROM and IEC/IEEE bus.

7.1.2.2 Keyboard Matrix

8 vertical lines and 5 horizontal lines (COL0...COL7, ROW1...ROW5) are passed from the keyboard matrix to the keyboard-display module. If no key is pressed, ROW1...ROW5 are applied to HIGH potential. COL0...COL7 are kept at LOW potential by D303. As soon as a key is pressed, a horizontal line is connected to a vertical and the horizontal line assumes LOW state. The corresponding capacitor is discharged. D302 causes a delay and D305 causes an interrupt (KEYINT) due to debouncing. Reading the key code, D303 becomes high-impedance, such that all vertical lines which are not connected via the closed key assume HIGH potential. The discharged capacitor ensures that the corresponding vertical line is kept LOW during the access time.

7.1.2.3 IEC/IEEE Interface

The IEC/IEEE-bus interface, which consists of the integrated IEC/IEEE-bus component D250 and the two components D260, D255 implements the interface according to the IEEE standard 488-1978. This component independently handles the handshake with data transfer. The interrupt generated with a change of status is passed to the pin HAI 0 of the CPU.

7.1.3 Analog Section

The analog section of the controller module provides the modulation signals required for AM and FM modes. It consists of an AF synthesizer and the AM modulation path.

7.1.3.1 AF Synthesizer

The output frequency of the modulation generator is generated by means of direct digital synthesis.

The DDS component D420 which contains a 32-bit adder, two 32-bit incremental memories, sine ROM and an interface for serial data transmission represents the nucleus of the synthesizer. The adder periodically increments at a clock frequency of 2.147484 MHz. The clock is provided by the crystal oscillator B401. The addresses of the sine ROM are controlled by the 13 high-order bits of the sum. The sine ROM stores the amplitude values of one sine-wave period. The 12 high-order bits of the amplitude values of one sine-wave are passed to a D/A converter which supplies a staircase signal. The two 6-bit D-registers (D430 und D440) suppress the different propagation delays of the sine ROM contained in the DDS component. A sample-&-hold switch suppresses the settling procedures of the D/A converter. A following 600-kHz lowpass provides for sufficient suppression of the clock frequency. The $\sin X/X$ compensation is realized by R491 and C490.

7.1.3.2 AM-Modulation Path

The analog switch D500, D510 and D550 is used to select the internal or external AM signal. The window discriminator (N544) which is connected in parallel to the input monitors the amplitude of the external modulation signal and, in case of undershoots or overshoots, supplies the signals AMKOMLO or AMKOMHI to the processor D10.

7.2 Test Instruments and Utilities

- Digital multimeter (e.g., R&S UDS5)
- DC-voltage source (e.g., R&S NGT)
- Audio analyzer (e.g., R&S UPA)
- Frequency generator (e.g., R&S SPN)
- RMS voltmeter (e.g., R&S URE3)
- Spectrum analyzer (e.g., R&S FSA)
- Oscilloscope
- Frequency counter

7.3 Troubleshooting

No signal provided at LFOUT (X3.23)	Check clock generator at X401
	Check signal at P405
	Check S&H circuit at P409
	Check lowpassfilter and amplifier N520 at P530
AM-INT at AMMOD (X3.34) faulty	Check switches D510 and D550 and amplifier N530
AM-EXT at AMMOD (X3.34) faulty	Check switches D500 and D550 and amplifier N530

7.4 Testing and Adjustment

All measured values indicated without tolerances are recommended values. Voltages given without any further detail are dc voltages.

7.4.1 Testing the Power Supply

- Connect an ammeter into the supply lines of the individual supply voltages
- Check the power consumption of the module.
The rated values of individual supply voltages can be looked up under "External Interfaces".

7.4.2 Setting the Power-Fail Threshold

- Set the ac supply voltage such that 7.1 V \pm 0.1 V are applied to X3.13 (U5VC).
- Adjust R139 such that the logic level at D100.10 is just changing (from H to L or L to H).

7.4.3 Setting the Reference Voltage

- Set dc voltage at test point P101 to +5.12 V \pm 1 mV using R102.

7.4.4 Adjustment of the AM-EXT Voltage Comparator

- Set the voltage at test point P513 to -1.02V \pm 1mV using R550.

7.4.5 Adjusting Level INT1

- Setting: 1kHz
- Connect calibrated ac voltmeter to INT1 (X3.32).
- Adjust output amplitude at ac voltmeter to 0.7071Vrms using R450.

7.4.6 0V-Adjustment of INT1 DC Offset

- Setting: AF 1kHz
- Connect dc voltmeter to INT1 (X3.32).
- Adjust dc offset to 0V using R520.

7.4.7 Testing the Diagnosis Inputs

- Connect dc voltmeter to test point P100.
- Setting: SPEC 109
SPEC 40 (GAIN16 D105.5 LOW).
- The measured voltage must be +2.56V \pm 20mV.
- Setting: SPEC 39 (GAIN16 D105.5 HIGH).

The measured voltage must be +2.56V \pm 50mV.

- Setting: RF 1GHz
SPEC 40 (GAIN16 D105.5 LOW).
SPEC 115

• Measure the voltage at X3.6.
The voltage at P100 must be +2.56 V minus half the voltage at X3.6 $\pm 20\text{mV}$.

- Setting: SPEC 39 (GAIN16 D105.5 HIGH).

• Measure the voltage at X3.6.
The voltage at P100 must be +2.56V minus sixteen times half the voltage at X3.6 $\pm 100\text{mV}$.

7.4.8 Testing the Keyboard Interrupt

- Connect an oscilloscope to P305. Press any key.

A LOW pulse with a pulse duration of approx. 2.5 ms must be measurable on the oscilloscope.

7.4.9 Testing the RAM Backup Voltage

- Measure the battery voltage directly at the battery terminals.
- Switch off the supply voltages.
- The measured battery voltage (tol. -10mV) is to be applied to D210.28.

7.4.10 Testing the Frequency Accuracy

- Setting: AF 100kHz
- Connect calibrated frequency counter to AF INT.
- Measure frequency. max. error $\pm 10\text{Hz}$.

7.4.11 Testing Level Accuracy

7.4.11.1 Frequency Response

- Setting: Vary AF between 10Hz and 500kHz.
- Connect calibrated ac voltmeter to AF INT.
- Measure level and compare to the table below.
Frequency response of 10Hz

up to 50kHz	<0.2dB
up to 100kHz	<0.3dB
up to 500kHz	<0.5dB

7.4.11.1 Setting Errors

- Setting: AF 1kHz
AM INT ON
- Connect calibrated ac voltmeter to outputs AF INT, INT1 (X3.32) and AMMOD (X3.34).
- Check output signals.

AF INT	0.7071Vrms	
INT1	0.7071Vrms	(X3.32)
AMMOD	0.7071Vrms (X3.34)	max. error $\pm 1\%$

7.4.11.3 INT1 DC-Offset

- Connect dc voltmeter to INT1 (X3.32).
- Absolute value of DC voltage must be < 5 mV.

7.4.12 Testing the Spectral Purity

7.4.12.1 Testing Distortion

Setting:

- Vary AF between 20 Hz and 100 kHz.
- Connect distortion meter to AFOUT.
- Measure distortion with various frequencies.
Distortion must be <0.1%.

7.4.12.2 Testing Harmonic and Nonharmonic Spuriae

Setting:

- Vary AF between 100 kHz and 500 kHz.
- Connect spectrum analyzer to AFOUT ($Z_{in} = 1M\Omega$).

Suppression of harmonics and nonharmonics must be < -40 dBc.

7.4.13 Testing the AM Output Switchover

Setting: AF 10kHz
AM INT ON

- Connect oscilloscope to AMMOD (X3.34).
- A 10-kHz sinewave signal must be visible on the oscilloscope.

Setting: AM EXT AC

- Shorting jumper X501 between X501.1 and X501.2
- Connect AF generator to AM EXT.

AF generator setting: frequency 1kHz
voltage 0.7071Vrms

- Test AMMOD (X3.34) signal. The voltage applied should be 0.7071Vrms.
Max. error $\pm 1\%$

7.4.14 Testing the Voltage Comparator for AM-EXT

Setting: AM EXT DC ON

- Connect AF generator to AM EXT.

AF-generator setting: frequency 1kHz
voltage 0.7071Vrms

The two outputs D545.13 and D545.12 must be LOW.

- Increase level to 0.735Vrms.

Output level at D545.13 must be HIGH.

- Adjust level to 0.680Vrms.

Level at D545.12 must be HIGH.

7.5 Disassembly and Assembly

Subsequent to opening the instrument and undoing the screws, the module can be removed from the frame. After undoing the screws of the screening covers, the module is accessible from both sides. Installation of the module and reassembly of the instrument are carried out in the reverse order.

7.6 External Interfaces

Pin	Name	Input/Output	Origin/Dest.	Specified range	Signal description
X1.1	VA5-P	Output	A1 FRONT X1.1	+4.9Vto+5.3V max.340mA	+5V supply voltage
X1.2	SERCLK	Output	A1 FRONT X1.2	HCMOS level	Serial clock
X1.3	VA5-P	Output	A1 FRONT X1.3	+4.9Vto+5.3V max.340mA	+5V supply voltage
X1.4	SERDATA	Output	A1 FRONT X1.4	HCMOS level	Serial data
X1.6	DIS1STB#	Output	A1 FRONT X1.6	HCMOS level	Display strobe 1
X1.8	DIS2STB#	Output	A1 FRONT X1.8	HCMOS level	Display strobe 2
X1.10	LEDSTB	Output	A1 FRONT X1.10	HCMOS level	LED strobe
X1.11	COL7	Input	A1 FRONT X1.11	HCMOS level	Key code
X1.12	C/D#	Output	A1 FRONT X1.12	HCMOS level	
X1.13	COL6	Input	A1 FRONT X1.13	HCMOS level	Key code
X1.14	DISBUSY	Input	A1 FRONT X1.14	HCMOS level	Control line
X1.15	COL5	Input	A1 FRONT X1.15	HCMOS level	Key code
X1.16	RES#	Output	A1 FRONT X1.16	HCMOS level	Reset
X1.17	COL4	Input	A1 FRONT X1.17	HCMOS level	Key code
X1.18	ROW5	Input	A1 FRONT X1.18	HCMOS level	Key code
X1.19	COL3	Input	A1 FRONT X1.19	HCMOS level	Key code
X1.20	ROW4	Input	A1 FRONT X1.20	HCMOS level	Key code
X1.21	COL2	Input	A1 FRONT X1.21	HCMOS level	Key code
X1.22	ROW3	Input	A1 FRONT X1.22	HCMOS level	Key code
X1.23	COL1	Input	A1 FRONT X1.23	HCMOS level	Key code
X1.24	ROW2	Input	A1 FRONT X1.24	HCMOS level	Key code
X1.25	COL0	Input	A1 FRONT X1.25	HCMOS level	Key code
X1.26	ROW1	Input	A1 FRONT X1.26	HCMOS level	Key code
X2.6	ATN	Bidirect.	IEC/IEEE bus	HCMOS level	Control line
X2.8	SRQ	Bidirect.	IEC/IEEE bus	HCMOS level	Control line
X2.10	IFC	Bidirect.	IEC/IEEE bus	HCMOS level	Control line
X2.12	NDAC	Bidirect.	IEC/IEEE bus	HCMOS level	Control line
X2.14	NFRD	Bidirect.	IEC/IEEE bus	HCMOS level	Control line
X2.16	DAV	Bidirect.	IEC/IEEE bus	HCMOS level	Control line
X2.17	REN	Bidirect.	IEC/IEEE bus	HCMOS level	Control line
X2.18	EOI	Bidirect.	IEC/IEEE bus	HCMOS level	Control line
X2.19	DIO8	Bidirect.	IEC/IEEE bus	HCMOS level	Data bus
X2.20	DIO4	Bidirect.	IEC/IEEE bus	HCMOS level	Data bus
X2.21	DIO7	Bidir.	IEC/IEEE bus	HCMOS level	Data bus
X2.22	DIO3	Bidir.	IEC/IEEE bus	HCMOS level	Data bus
X2.23	DIO6	Bidir.	IEC/IEEE bus	HCMOS level	Data bus
X2.24	DIO2	Bidir.	IEC/IEEE bus	HCMOS level	Data bus
X2.25	DIO5	Bidir.	IEC/IEEE bus	HCMOS level	Data bus
X2.26	DIO1	Bidir.	IEC/IEEE bus	HCMOS level	Data bus

Pin	Name	Input/Output	Origin/Dest.	Specified range	Signal description
X3.2	SERCLK	Output	A3 MBRD X3.2	HCMOS level	Serial clock
X3.3	SEQ	Input	A3 MBRD X3.3	HCMOS level	Sequence
X3.4	SERDATA	Output	A3 MBRD X3.4	HCMOS level	Serial data
X3.5	frei				
X3.6	DIAG-5V	Input	A3 MBRD X3.6	-5V to +5V	Diagnosis/Calibration
X3.8	VA15-N	Input	A3 MBRD X3.8	-15.5V to -14.4V max.75mA	-15V Supply voltage
X3.9	VA15-P	Input	A3 MBRD X3.9	+14.4V to +15.6V max.65mA	+15V Supply voltage
X3.10	VA5-P	Input	A3 MBRD X3.10	+4.9V to 5.3V max.340mA	+5V supply voltage
X3.12	VA5-P	Input	A3 Motherb. X3.12	+4.9 Vto 5.3V max.340mA	+5V supply voltage
X3.13	U5VC	Input	A3 MBRD X3.13	+7.2V...+7.8V	Overvoltage for reset
X3.14	HF1STB	Output	A3 MBRD X3.14	HCMOS level	Strobe 1 synthesizer
X3.15	HF2STB	Output	A3 MBRD X3.15	HCMOS level	Strobe 2 synthesizer
X3.16	AT1STB	Output	A3 MBRD X3.16	HCMOS level	Strobe 1 Output amplifier
X3.17	AT2STB	Output	A3 MBRD X3.17	HCMOS level	Strobe 2 Output amplifier
X3.18	AT3STB	Output	A3 MBRD X3.18	HCMOS level	Strobe 3 Output amplifier
X3.19	ELSTB	Output	A3 MBRD X3.19	HCMOS level	Strobe attenuator
X3.20	HFINT	Input	A3 MBRD X3.20	HCMOS level	Interrupt
X3.21	REFOFF	Output	A3 MBRD X3.21	HCMOS level	Option on/off
X3.22	HFOVERLOAD	Input	A3 MBRD X3.22	HCMOS level	Overload RF
X3.23	FMKOMLO	Input	A3 MBRD X3.23	HCMOS level	FM EXT too small
X3.24	FMKOMHI	Input	A3 MBRD X3.24	HCMOS level	FM EXT too large
X3.25	OPTERKREF	Input	A3 MBRD X3.25	HCMOS level	Identif. of ref. oscill.
X3.26	OVENCOLD	Input	A3 MBRD X3.26	HCMOS level	Thermostat option
X3.28	LFOUT	Output	A3 MBRD X3.28	1Vs	Modulation generator
X3.30	AMEXT	Input	A3 MBRD X3.30	1Vs	Ext. Input AM
X3.32	INT1	Output	A3 MBRD X3.32	1Vs	Int FM Output
X3.34	AMMOD	Output	A3 MBRD X3.34	1Vs	AM Mod. Output

GND

X1.5/7/9

X2.1/2/3/4/5/7/9/11/13/15

X3.1/7/11/27/29/31/33



ROHDE & SCHWARZ

**Schaltteillisten
numerisch geordnet
Part lists
in numerical order
Listes des pièces détachées
par numéros de référence**

Für diese Unterlage behalten wir uns alle Rechte vor.

Kennz. Comp. No.	Benennung Designation	Sachnummer Stock No.	Hersteller Manufacturer	Bezeichnung Designation	enthalten in contained in	
	XX VARIANTENERKLAERUNG IDENTIFICATION OF MODELS VAR 02 = GRUNDAUSFUEHRUNG MOD 02 = BASIC MODEL VAR 04 = SMY 41/44/45 MOD 04 = SMY 41/44/45 XX ZUEGH.STROML. CIRC.DIAGR. 1062.6309 S					
B100	EQ 10,000MHZ CL30PF HC43U QUARTZ CRYSTAL UNIT 10MHZ	EQ 0091.0250.00	PHILIPS	N. R&S SACHNUMMER		
B401	ED 2,147484MHZ-QU.OSZ 5V CLOCK OSCILLATOR	1036.8120.00	TELEQUARZ	MCO 1500 B		
C10	CE 220UF+-20%10V RM2,5 ELECTROLYTIC CAPACITOR	CE 0008.7927.00	PANASONIC	ECA-1AFG221I		
C100	CC 1NF+-1% 50V NPO 1206 SMD CERAMIC CAPACITOR	CC 0007.7398.00	PHILIPS_CO	2222 863 *8102		
C105	CC 22PF+-1%50V NPO 1206 CERAMIC CHIP CAPACITOR	CC 0099.8396.00	MURATA	GRM42-6COG 220F 50PT		
C110	CC 1NF+-1% 50V NPO 1206 SMD CERAMIC CAPACITOR	CC 0007.7398.00	PHILIPS_CO	2222 863 *8102		
C111	CC 1NF+-1% 50V NPO 1206 SMD CERAMIC CAPACITOR	CC 0007.7398.00	PHILIPS_CO	2222 863 *8102		
C112	CE 100UF+-20%25V RD8X9,5 ELECTROLYTIC CAPACITOR	0803.0580.00	MATSUSHITA	ECE-A1ESS-101		
C113	CE 100UF+-20%25V RD8X9,5 ELECTROLYTIC CAPACITOR	0803.0580.00	MATSUSHITA	ECE-A1ESS-101		
C114	CC 2,2NF+-10%50VX7R 1206 CERAMIC CHIP CAPACITOR	CC 0099.8444.00	PHILIPS_CO	2222 581 16618		
C115	CC 100NF+-10%50V X7R 1206 CERAMIC CHIP CAPACITOR	CC 0007.5237.00	PHILIPS_CO	2238 581 15649		
C116	CC 100NF+-10%50V X7R 1206 CERAMIC CHIP CAPACITOR	CC 0007.5237.00	PHILIPS_CO	2238 581 15649		
C117	CC 100NF+-10%50V X7R 1206 CERAMIC CHIP CAPACITOR	CC 0007.5237.00	PHILIPS_CO	2238 581 15649		
C118	CC 1NF+-1% 50V NPO 1206 SMD CERAMIC CAPACITOR	CC 0007.7398.00	PHILIPS_CO	2222 863 *8102		
C119	CC 10NF+-10%50V X7R 1206 CERAMIC CHIP CAPACITOR	CC 0099.8521.00	MURATA	GRM42-6X7R103K 50PT		
C120	CC 1NF+-1% 50V NPO 1206 SMD CERAMIC CAPACITOR	CC 0007.7398.00	PHILIPS_CO	2222 863 *8102		
C121	CC 1NF+-1% 50V NPO 1206 SMD CERAMIC CAPACITOR	CC 0007.7398.00	PHILIPS_CO	2222 863 *8102		
C122	CC 1NF+-1% 50V NPO 1206 SMD CERAMIC CAPACITOR	CC 0007.7398.00	PHILIPS_CO	2222 863 *8102		
C123	CC 1NF+-1% 50V NPO 1206 SMD CERAMIC CAPACITOR	CC 0007.7398.00	PHILIPS_CO	2222 863 *8102		
C125	CC 100NF+-10%50V X7R 1206 CERAMIC CHIP CAPACITOR	CC 0007.5237.00	PHILIPS_CO	2238 581 15649		
C139	CC 100NF+-10%50V X7R 1206 CERAMIC CHIP CAPACITOR	CC 0007.5237.00	PHILIPS_CO	2238 581 15649		
C140	CC 33PF+-1%50V NPO 1206 CERAMIC CHIP CAPACITOR	CC 0099.8780.00	MURATA	GRM42-6COG 330F 50PT		
C141	CC 33PF+-1%50V NPO 1206 CERAMIC CHIP CAPACITOR	CC 0099.8780.00	MURATA	GRM42-6COG 330F 50PT		
C143	CC 100NF+-10%50V X7R 1206 CERAMIC CHIP CAPACITOR	CC 0007.5237.00	PHILIPS_CO	2238 581 15649		
C144	CE 220UF+-20%10V RM2,5 ELECTROLYTIC CAPACITOR	CE 0008.7927.00	PANASONIC	ECA-1AFG221I		
C145	CE 220UF+-20%10V RM2,5 ELECTROLYTIC CAPACITOR	CE 0008.7927.00	PANASONIC	ECA-1AFG221I		
C146	CC 100NF+-10%50V X7R 1206 CERAMIC CHIP CAPACITOR	CC 0007.5237.00	PHILIPS_CO	2238 581 15649		
C150	CC 100NF+-10%50V X7R 1206 CERAMIC CHIP CAPACITOR	CC 0007.5237.00	PHILIPS_CO	2238 581 15649		
C170	CC 100PF+-1%50V NPO 1206 CERAMIC CHIP CAPACITOR	CC 0099.8415.00	MURATA	GRM42-6COG 101F 50PT		
C171	CC 100PF+-1%50V NPO 1206 CERAMIC CHIP CAPACITOR	CC 0099.8415.00	MURATA	GRM42-6COG 101F 50PT		
C173	CC 1NF+-1% 50V NPO 1206 SMD CERAMIC CAPACITOR	CC 0007.7398.00	PHILIPS_CO	2222 863 *8102		
C174	CC 1NF+-1% 50V NPO 1206 SMD CERAMIC CAPACITOR	CC 0007.7398.00	PHILIPS_CO	2222 863 *8102		
C185	CC 100NF+-10%50V X7R 1206 CERAMIC CHIP CAPACITOR	CC 0007.5237.00	PHILIPS_CO	2238 581 15649		
.. 190						
MENP5	413 3PUA	ÄI	Datum Date	Schaltteilliste für Parts list for	Sachnummer Stock No.	Blatt-Nr. Page
	ROHDE & SCHWARZ	18	16.09.97	ED PROCESSOR PROCESSOR	1062.6309.01 SA	1+

095.0028-0693

Kannz. Comp. No.	Benennung Designation	Sachnummer Stock No.	Hersteller Manufacturer	Bezeichnung Designation	enthalten in contained in
C191	CC 100NF+-10%50V X7R 1206 CERAMIC CHIP CAPACITOR	CC 0007.5237.00	PHILIPS_CO	2238 581 15649	
C200	CC 100NF+-10%50V X7R 1206 CERAMIC CHIP CAPACITOR	CC 0007.5237.00	PHILIPS_CO	2238 581 15649	
C201	CC 100NF+-10%50V X7R 1206 CERAMIC CHIP CAPACITOR	CC 0007.5237.00	PHILIPS_CO	2238 581 15649	
C203	CC 100NF+-10%50V X7R 1206 CERAMIC CHIP CAPACITOR	CC 0007.5237.00	PHILIPS_CO	2238 581 15649	
C204	CC 100NF+-10%50V X7R 1206 CERAMIC CHIP CAPACITOR	CC 0007.5237.00	PHILIPS_CO	2238 581 15649	
C205	CC 10PF+-0,25 50VNPO 1206 CERAMIC CHIP CAPACITOR	CC 0099.8480.00	MURATA	GRM42-6COG 100 C5OPT	
C210	CC 100NF+-10%50V X7R 1206 CERAMIC CHIP CAPACITOR	CC 0007.5237.00	PHILIPS_CO	2238 581 15649	
C211	CC 100NF+-10%50V X7R 1206 CERAMIC CHIP CAPACITOR	CC 0007.5237.00	PHILIPS_CO	2238 581 15649	
C220	CC 10PF+-0,25 50VNPO 1206 CERAMIC CHIP CAPACITOR	CC 0099.8480.00	MURATA	GRM42-6COG 100 C5OPT	
C230	CC 100PF+-1%50V NPO 1206 CERAMIC CHIP CAPACITOR	CC 0099.8415.00	MURATA	GRM42-6COG 101F 50PT	
..236					
C301	CC 1NF+-1% 50V NPO 1206 SMD CERAMIC CAPACITOR	CC 0007.7398.00	PHILIPS_CO	2222 863 *8102	
C302	CC 1NF+-1% 50V NPO 1206 SMD CERAMIC CAPACITOR	CC 0007.7398.00	PHILIPS_CO	2222 863 *8102	
C303	CC 1NF+-1% 50V NPO 1206 SMD CERAMIC CAPACITOR	CC 0007.7398.00	PHILIPS_CO	2222 863 *8102	
C304	CC 1NF+-1% 50V NPO 1206 SMD CERAMIC CAPACITOR	CC 0007.7398.00	PHILIPS_CO	2222 863 *8102	
C305	CC 1NF+-1% 50V NPO 1206 SMD CERAMIC CAPACITOR	CC 0007.7398.00	PHILIPS_CO	2222 863 *8102	
C306	CC 100PF+-1%50V NPO 1206 CERAMIC CHIP CAPACITOR	CC 0099.8415.00	MURATA	GRM42-6COG 101F 50PT	
C307	CC 100PF+-1%50V NPO 1206 CERAMIC CHIP CAPACITOR	CC 0099.8415.00	MURATA	GRM42-6COG 101F 50PT	
C308	CC 100PF+-1%50V NPO 1206 CERAMIC CHIP CAPACITOR	CC 0099.8415.00	MURATA	GRM42-6COG 101F 50PT	
C310	CC 100NF+-10%50V X7R 1206 CERAMIC CHIP CAPACITOR	CC 0007.5237.00	PHILIPS_CO	2238 581 15649	
..316					
C320	CC 390PF+-1%50V NPO 1206 CERAMIC CHIP CAPACITOR	CC 0099.8880.00	PHILIPS_CO	2238 863 18391	
..327					
C330	CC 10NF+-10%50V X7R 1206 CERAMIC CHIP CAPACITOR	CC 0099.8521.00	MURATA	GRM42-6X7R103K 50PT	
..334					
C340	CC 33NF+-10% 50V X7R 1206 CERAMIC CHIP CAPACITOR	CC 0007.5172.00	PHILIPS_CO	2238 581 16634	
C400	CC 100PF+-1%50V NPO 1206 CERAMIC CHIP CAPACITOR	CC 0099.8415.00	MURATA	GRM42-6COG 101F 50PT	
C402	CE 220UF+-20%10V RM2,5 ELECTROLYTIC CAPACITOR	CE 0008.7927.00	PANASONIC	ECA-1AFG221I	
C404	CE 100UF+-20%25V RDX9,5 ELECTROLYTIC CAPACITOR	0803.0580.00	MATSUSHITA	ECE-A1ESS-101	
C406	CE 100UF+-20%25V RDX9,5 ELECTROLYTIC CAPACITOR	0803.0580.00	MATSUSHITA	ECE-A1ESS-101	
C409	CC 100NF+-10%50V X7R 1206 CERAMIC CHIP CAPACITOR	CC 0007.5237.00	PHILIPS_CO	2238 581 15649	
C417	CC 100PF+-1%50V NPO 1206 CERAMIC CHIP CAPACITOR	CC 0099.8415.00	MURATA	GRM42-6COG 101F 50PT	
C418	CC 100PF+-1%50V NPO 1206 CERAMIC CHIP CAPACITOR	CC 0099.8415.00	MURATA	GRM42-6COG 101F 50PT	
C419	CC 100PF+-1%50V NPO 1206 CERAMIC CHIP CAPACITOR	CC 0099.8415.00	MURATA	GRM42-6COG 101F 50PT	
C420	CC 100NF+-10%50V X7R 1206 CERAMIC CHIP CAPACITOR	CC 0007.5237.00	PHILIPS_CO	2238 581 15649	
C421	CC 100PF+-1%50V NPO 1206 CERAMIC CHIP CAPACITOR	CC 0099.8415.00	MURATA	GRM42-6COG 101F 50PT	
C430	CC 100NF+-10%50V X7R 1206 CERAMIC CHIP CAPACITOR	CC 0007.5237.00	PHILIPS_CO	2238 581 15649	
C440	CC 100NF+-10%50V X7R 1206 CERAMIC CHIP CAPACITOR	CC 0007.5237.00	PHILIPS_CO	2238 581 15649	
C449	CC 100NF+-10%50V X7R 1206 CERAMIC CHIP CAPACITOR	CC 0007.5237.00	PHILIPS_CO	2238 581 15649	
C450	CC 100NF+-10%50V X7R 1206 CERAMIC CHIP CAPACITOR	CC 0007.5237.00	PHILIPS_CO	2238 581 15649	
C451	CC 100NF+-10%50V X7R 1206 CERAMIC CHIP CAPACITOR	CC 0007.5237.00	PHILIPS_CO	2238 581 15649	
C452	CC 100NF+-10%50V X7R 1206 CERAMIC CHIP CAPACITOR	CC 0007.5237.00	PHILIPS_CO	2238 581 15649	
C453	CC 100NF+-10%50V X7R 1206 CERAMIC CHIP CAPACITOR	CC 0007.5237.00	PHILIPS_CO	2238 581 15649	

Für diese Unterlage behalten wir uns alle Rechte vor.

MENP5	413 3PUA	ÄI	Datum Date	Schaltteilliste für Parts list for	Sachnummer Stock No.	Blatt-Nr. Page
	18	16.09.97	ED PROCESSOR PROCESSOR	1062.6309.01 SA	2+	

095.0028-0693

Für diese Unterlage behalten
wir uns alle Rechte vor.

Kennz. Comp. No.	Benennung Designation	Sachnummer Stock No.	Hersteller Manufacturer	Bezeichnung Designation	enthalten in contained in
C454	CC 10PF+-0,25 50VNPO 1206 CERAMIC CHIP CAPACITOR	CC 0099.8480.00	MURATA	GRM42-6COG 100 C50PT	
C460	CC 47PF+-1%50V COG 1206 CERAMIC CHIP CAPACITOR	CC 0099.8496.00	MURATA	GRM42-6COG 470F 50PT	
C461	CC 47PF+-1%50V COG 1206 CERAMIC CHIP CAPACITOR	CC 0099.8496.00	MURATA	GRM42-6COG 470F 50PT	
C472	CC 100NF+-10%50V X7R 1206 CERAMIC CHIP CAPACITOR	CC 0007.5237.00	PHILIPS_CO	2238 581 15649	
C473	CC 100NF+-10%50V X7R 1206 CERAMIC CHIP CAPACITOR	CC 0007.5237.00	PHILIPS_CO	2238 581 15649	
C474	CC 100NF+-10%50V X7R 1206 CERAMIC CHIP CAPACITOR	CC 0007.5237.00	PHILIPS_CO	2238 581 15649	
C475	CC 100NF+-10%50V X7R 1206 CERAMIC CHIP CAPACITOR	CC 0007.5237.00	PHILIPS_CO	2238 581 15649	
C480	CK 100PF+-1%63V6,3QUX11KP CAPACITOR	CK 0337.4654.00	SIEMENS	B33531-A5101-F	
C481	CC 12PF+-1% 50V NPO 1206 CERAMIC CHIP CAPACITOR	CC 0099.8744.00	MURATA	GRM42-6COG 120 F50PT	
C485	CC 100NF+-10%50V X7R 1206 CERAMIC CHIP CAPACITOR	CC 0007.5237.00	PHILIPS_CO	2238 581 15649	
C490	CC 82PF+-1%50V NPO 1206 CERAMIC CHIP CAPACITOR	CC 0099.8821.00	MURATA	GRM42-6COG 820F 50PT	
C492	CC 100NF+-10%50V X7R 1206 CERAMIC CHIP CAPACITOR	CC 0007.5237.00	PHILIPS_CO	2238 581 15649	
C493	CC 100NF+-10%50V X7R 1206 CERAMIC CHIP CAPACITOR	CC 0007.5237.00	PHILIPS_CO	2238 581 15649	
C500	CK 100PF+-1%63V6,3QUX11KP CAPACITOR	CK 0337.4654.00	SIEMENS	B33531-A5101-F	
C501	CK 330PF+-1%63V6,3X11 KP PLASTC-FOIL CAPACITOR	CK 0283.1647.00	SIEMENS	B33531-A5331-F	
C502	CK 330PF+-1%63V6,3X11 KP PLASTC-FOIL CAPACITOR	CK 0283.1647.00	SIEMENS	B33531-A5331-F	
C503	CK 300PF+-1%63V6,3QUX11KP CAPACITOR	CK 0334.4330.00	SIEMENS	B33531-A5301-F	
C504	CK 120PF+-1%63V 6,3X11 KP FOIL CAPACITOR	CK 0099.3613.00	SIEMENS	B33531-A5121-F	
C505	CC 100NF+-10%50V X7R 1206 CERAMIC CHIP CAPACITOR	CC 0007.5237.00	PHILIPS_CO	2238 581 15649	
C506	CC 100PF+-1%50V NPO 1206 CERAMIC CHIP CAPACITOR	CC 0099.8415.00	MURATA	GRM42-6COG 101F 50PT	
C510	CC 4,7PF+-0,25 50VNPO1206 CERAMIC CHIP CAPACITOR	CC 0007.8213.00	MURATA	GRM42-6COG 4R7C 50PT	
C530	CC 100PF+-1%50V NPO 1206 CERAMIC CHIP CAPACITOR	CC 0099.8415.00	MURATA	GRM42-6COG 101F 50PT	
C530	CC 100PF+-1%50V NPO 1206 CERAMIC CHIP CAPACITOR NUR VAR/ONLY MOD: 02	CC 0099.8415.00	MURATA	GRM42-6COG 101F 50PT	
C530	CC 100PF+-1%50V NPO 1206 CERAMIC CHIP CAPACITOR NUR VAR/ONLY MOD: 04 NICHT BESTUECKT/NOT FITTED	CC 0099.8415.00	MURATA	GRM42-6COG 101F 50PT	
C531	CC 100PF+-1%50V NPO 1206 CERAMIC CHIP CAPACITOR NUR VAR/ONLY MOD: 02	CC 0099.8415.00	MURATA	GRM42-6COG 101F 50PT	
C531	RG 221 OHM+-1%TK100 1206 RESISTOR CHIP NUR VAR/ONLY MOD: 04 FUER C531"	RG 0007.5614.00	ROEDERSTEI	DC2 2210HM 1%TK100	
C532	CC 100PF+-1%50V NPO 1206 CERAMIC CHIP CAPACITOR	CC 0099.8415.00	MURATA	GRM42-6COG 101F 50PT	
C533	CC 100PF+-1%50V NPO 1206 CERAMIC CHIP CAPACITOR	CC 0099.8415.00	MURATA	GRM42-6COG 101F 50PT	
C538	CC 22PF+-1%50V NPO 1206 CERAMIC CHIP CAPACITOR	CC 0099.8396.00	MURATA	GRM42-6COG 220F 50PT	
C539	CC 100PF+-1%50V NPO 1206 CERAMIC CHIP CAPACITOR	CC 0099.8415.00	MURATA	GRM42-6COG 101F 50PT	
C540	CC 100PF+-1%50V NPO 1206 CERAMIC CHIP CAPACITOR	CC 0099.8415.00	MURATA	GRM42-6COG 101F 50PT	
C541	CC 15PF+-1% 50V NPO 1206 CERAMIC CHIP CAPACITOR NUR VAR/ONLY MOD: 02	CC 0099.8750.00	MURATA	GRM42-6COG 150F 50PT	
C542	CC 15PF+-1% 50V NPO 1206 CERAMIC CHIP CAPACITOR NUR VAR/ONLY MOD: 04 NICHT BESTUECKT/NOT FITTED	CC 0099.8750.00	MURATA	GRM42-6COG 150F 50PT	
C542	CE 220UF+-20%10V RM2,5 ELECTROLYTIC CAPACITOR	CE 0008.7927.00	PANASONIC	ECA-1AFG221I	
C543	CE 220UF+-20%10V RM2,5 ELECTROLYTIC CAPACITOR	CE 0008.7927.00	PANASONIC	ECA-1AFG221I	

MENP5

413 3PUA

Äi

Datum
Date

Schaltteilliste für
Parts list for

Sachnummer
Stock No.

Blatt-Nr.
Page



ROHDE & SCHWARZ

18

16.09.97

ED PROCESSOR
PROCESSOR

1062.6309.01 SA

3+

Für diese Unterlage behalten wir uns alle Rechte vor.

Kennz. Comp. No.	Benennung Designation	Sachnummer Stock No.	Hersteller Manufacturer	Bezeichnung Designation	enthalten in contained in	
C555	CK 1UF+-5%50V7,5X5,5X10,5 CAPACITOR	CK 0099.2998.00	ERD	MKT 1826-510/054-R		
C556	CK 1UF+-5%50V7,5X5,5X10,5 CAPACITOR	CK 0099.2998.00	ERD	MKT 1826-510/054-R		
C567	CC 100PF+-1%50V NPO 1206 CERAMIC CHIP CAPACITOR	CC 0099.8415.00	MURATA	GRM42-6COG 101F 50PT		
C568	CC 100PF+-1%50V NPO 1206 CERAMIC CHIP CAPACITOR	CC 0099.8415.00	MURATA	GRM42-6COG 101F 50PT		
C575	CC 100NF+-10%50V X7R 1206 CERAMIC CHIP CAPACITOR	CC 0007.5237.00	PHILIPS_CO	2238 581 15649		
C578	CC 100NF+-10%50V X7R 1206 CERAMIC CHIP CAPACITOR	CC 0007.5237.00	PHILIPS_CO	2238 581 15649		
C579	CC 100NF+-10%50V X7R 1206 CERAMIC CHIP CAPACITOR	CC 0007.5237.00	PHILIPS_CO	2238 581 15649		
C580	CC 100NF+-10%50V X7R 1206 CERAMIC CHIP CAPACITOR	CC 0007.5237.00	PHILIPS_CO	2238 581 15649		
..587	C588	CE 100UF+-20%25V RD8X9,5 ELECTROLYTIC CAPACITOR	0803.0580.00	MATSUSHITA	ECE-A1ESS-101	
C589	CE 220UF+-20%10V RM2,5 ELECTROLYTIC CAPACITOR	CE 0008.7927.00	PANASONIC	ECA-1AFG221I		
C590	CC 100NF+-10%50V X7R 1206 CERAMIC CHIP CAPACITOR	CC 0007.5237.00	PHILIPS_CO	2238 581 15649		
C591	CC 100NF+-10%50V X7R 1206 CERAMIC CHIP CAPACITOR	CC 0007.5237.00	PHILIPS_CO	2238 581 15649		
C592	CC 100NF+-10%50V X7R 1206 CERAMIC CHIP CAPACITOR	CC 0007.5237.00	PHILIPS_CO	2238 581 15649		
..598	C599	CE 100UF+-20%25V RD8X9,5 ELECTROLYTIC CAPACITOR	0803.0580.00	MATSUSHITA	ECE-A1ESS-101	
D10	BC N80C196 16B.MCU+ADC IC MICROCONTROLLER	0010.6924.00	INTEL	N80C196KB		
D100	BO MAX691CWE SUPERVISOR IC UP VOLTAGE SUPERVISOR	1006.4162.00	MAXIM	MAX691CWE		
D105	BS DG419DY 1XUM ANALOGSCH ANALOG SWITCH	0746.0322.00	SILICONIX	DG419DY		
D107	BO REF02CP 5V 20MA VREF VOLTAGE REFERENCE	BO 0394.8732.00	PMI	REF-02CP		
D110	HS EPROM D110 EPROM D110	1062.6321.00				
D120	BL PC74HCT573T 8XD-FF 3S OCTAL D-TYPE FLIPFLOP	BL 0812.8796.00	PHILIPS_SE	(PC)74HCT573(D/T)		
D125	BC X24C16S14 2KX8 EEPROM SERIAL EEPROM	1028.8190.00	XICOR	X24C16S(14)		
D135	BL PC74HCT04T 6XINVERT HEXINVERTER	BL 0007.5372.00	PHILIPS_SE	(PC)74HCT04(D/T)		
D150	BL PC74HCT574T 8XD-FF 3S OCTAL D-TYPE FLIPFLOP	BL 0007.6727.00	PHILIPS	(PC)74HCT574(T)		
D160	BL PC74HCT574T 8XD-FF 3S OCTAL D-TYPE FLIPFLOP	BL 0007.6727.00	PHILIPS	(PC)74HCT574(T)		
D206	HS EPROM D206 EPROM D206	1062.6338.00				
D210	BC 84256-12LP 32KX8 SRAM RAM	0007.6985.00	NEC	UPD43256BGU-70LL		
D230	BL PC74HCT245T 8XTRANS OCTAL BUS TRANSCEIVER	BL 0007.5414.00	PHILIPS_SE	(PC)74HCT245(D/T)		
D250	BC NAT7210APD GPIB IF CON GPIB INTERFACE CONTROLLER	0010.9198.00	NATIONAL/I	NAT7210APD		
D255	BJ SN75160AN 8XBUS TRANSC BUS TRANSCEIVER	BJ 0345.6517.00	TEXAS	SN75160BN		
D260	BJ SN75161AN 8XBUS TRANSC BUS TRANSCEIVER	BJ 0345.6523.00	TEXAS	SN75161BN		
D301	BL PC74HCT147T 10T04 ENC PRIORITY ENCODER	BL 0007.6362.00	PHILIPS	(PC)74HCT147(T)		
D302	BL PC74HCT30T 8IN NAND NAND GATE	BL 0007.6233.00	PHILIPS_SE	(PC)74HCT30(D/T)		
D303	BL PC74HCT244T 8XBUFF 3S OCTAL BUFFER	BL 0007.6562.00	PHILIPS_SE	(PC)74HCT244D(T)		
D304	BL PC74HCT74T 2XD-FLIPFL DUAL D-TYPE FLIP FLOP	BL 0007.6262.00	PHILIPS_SE	(PC)74HCT74D(T)		
D305	BL PC74HCT123T 2XMONOFLOP DUAL MULTIVIBRATOR	BL 0007.6333.00	PHILIPS_SE	(PC)74HCT123(D/T)		
D311	BL PC74HCT147T 10T04 ENC PRIORITY ENCODER	BL 0007.6362.00	PHILIPS	(PC)74HCT147(T)		
D323	BL PC74HCT244T 8XBUFF 3S OCTAL BUFFER	BL 0007.6562.00	PHILIPS_SE	(PC)74HCT244D(T)		
D402	BL PC74HCT00T 4X2IN.NAND NAND GATE	BL 0007.6156.00	PHILIPS_SE	(PC)74HCT00D(T)		

MENP5	413 3PUA	Äi	Datum Date	Schaltteilliste für Parts list for	Sachnummer Stock No.	Blatt-Nr. Page
	18	16.09.97	ED PROCESSOR PROCESSOR	1062.6309.01 SA	4+	

095.0026-0693

Für diese Unterlage behalten wir uns alle Rechte vor.

Kennz. Comp. No.	Benennung Designation	Sachnummer Stock No.	Hersteller Manufacturer	Bezeichnung Designation	enthalten in contained in
D403	BL PC74HCT74T 2XD-FLIPFL DUAL D-TYPE FLIP FLOP	BL 0007.6262.00	PHILIPS_SE	(PC)74HCT74D(T)	
D420	BL HSP45102 33MHZ DDS-OSZ IC NUMERIC CONTR OSCILL.	1036.8143.00	HARRIS	HSP45102SC-33	
D430	BL PC74HCT174T 6XD-FF HEX D-TYPE FLIPFLOP	BL 0007.6456.00	PHILIPS	(PC)74HCT174(T)	
D440	BL PC74HCT174T 6XD-FF HEX D-TYPE FLIPFLOP	BL 0007.6456.00	PHILIPS	(PC)74HCT174(T)	
D450	BJ DAC80-CPI-I 1X12B-DAC D/A-CONVERTER	0300.6330.00	BURR_BROWN	DAC80CBI-I	
D500	BS DG419DY 1XUM ANALOGSCH ANALOG SWITCH	0746.0322.00	SILICONIX	DG419DY	
D510	BS DG419DY 1XUM ANALOGSCH ANALOG SWITCH	0746.0322.00	SILICONIX	DG419DY	
D545	BL PC74HCT123T 2XMONOFLOP DUAL MULTIVIBRATOR	BL 0007.6333.00	PHILIPS_SE	(PC)74HCT123(D/T)	
D550	BS DG411DY 4X ANALOGSCH ANALOG SWITCH	0920.1723.00	SILICONIX	DG411DY	
D555	BL PC74HCT4094T 8ST.SHREG SHIFT REGISTER	BL 0007.6885.00	PHILIPS	(PC)74HCT4094(D)	
G100	EB 3,4V LITHIUM-BATTERIE LI BATTERY	0565.1687.00	ACCU_SONNE	SL-750/P/009 1110750	
L10	LD 25UH 3A 0,0460HM CHOKE	LD 0026.4849.00	SIEMENS	B82111-B-C24	
L12	LD 10 UH 10% 3R3 144 MA CHOKE	LD 0026.4184.00	DALE	IM2	
L13	LD 10 UH 10% 3R3 144 MA CHOKE	LD 0026.4184.00	DALE	IM2	
L140	LD 56,0UH10%5,700HMO,100A CHOKE	LD 0067.3076.00	DALE	IM2	
L401	LD 10UH 10% 0,18A 1210 SMD-INDUCTOR	LD 0007.9255.00	SIEMENS	B82422-A1103-K100	
L403	LD 10UH 10% 0,18A 1210 SMD-INDUCTOR	LD 0007.9255.00	SIEMENS	B82422-A1103-K100	
L405	LD 10UH 10% 0,18A 1210 SMD-INDUCTOR	LD 0007.9255.00	SIEMENS	B82422-A1103-K100	
L472	LD 10UH 10% 0,18A 1210 SMD-INDUCTOR	LD 0007.9255.00	SIEMENS	B82422-A1103-K100	
L473	LD 10UH 10% 0,18A 1210 SMD-INDUCTOR	LD 0007.9255.00	SIEMENS	B82422-A1103-K100	
L500	LD 330 UH10%28,00HMO,045A CHOKE	LD 0067.3160.00	DALE	IM2	
L501	LD 470 UH10%42,00HMO,036A CHOKE	LD 0067.3182.00	DALE	IM2	
L502	LD 470 UH10%42,00HMO,036A CHOKE	LD 0067.3182.00	DALE	IM2	
L503	LD 330 UH10%28,00HMO,045A CHOKE	LD 0067.3160.00	DALE	IM2	
L590	LD 10UH 10% 0,18A 1210 SMD-INDUCTOR	LD 0007.9255.00	SIEMENS	B82422-A1103-K100	
L591	LD 10UH 10% 0,18A 1210 SMD-INDUCTOR	LD 0007.9255.00	SIEMENS	B82422-A1103-K100	
L592	LD 10UH 10% 0,18A 1210 SMD-INDUCTOR	LD 0007.9255.00	SIEMENS	B82422-A1103-K100	
N100	BO OPA2604AU 2XFET OPAMP IC DUAL OPAMP	2045.4943.00	BURR_BROWN	OPA2604AU	
N450	BO AD744KR FET OPAMP BIFET OPAMP	0854.1754.00	ANALOG_DEV	(AD)744KR	
N490	BO CLC430AJE CF OPAMP IC CURRENT FEEDBACK OPAMP	2032.2524.00	COMLINEAR	CL(C)430AJE	
N510	BO NE5534D OPAMP OPERATIONAL AMPLIFIER	0815.7555.00	SIGNETICS	NE5534(D)	
N520	BO AD744KR FET OPAMP BIFET OPAMP	0854.1754.00	ANALOG_DEV	(AD)744KR	
N530	BO TL072ACD 2XFET OPAMP OPERATIONAL AMPLIFIER	0803.1057.00	TEXAS	TL 072 ACDR	
N540	BO AD744KR FET OPAMP BIFET OPAMP	0854.1754.00	ANALOG_DEV	(AD)744KR	
N540	NUR VAR/ONLY MOD: 02 BO AD811JR VIDEOCF OPAMP IC OPAMP	2025.2997.00	ANALOG_DEV	AD811JR	
N544	NUR VAR/ONLY MOD: 04 BO LM2903D 2XLP COMPAR DUAL	0520.7734.00	SIGNETICS	LM2903(D)	

095.0026-0693

MENP5	413 3PUA	ÄI	Datum Date	Schaltteilliste für Parts list for	Sachnummer Stock No.	Blatt-Nr. Page
	ROHDE & SCHWARZ	18	16.09.97	ED PROCESSOR PROCESSOR	1062.6309.01 SA	5+

Für diese Unterlage behalten wir uns alle Rechte vor.

Kennz. Comp. No.	Benennung Designation	Sachnummer Stock No.	Hersteller Manufacturer	Bezeichnung Designation	enthalten in contained in
P100	VL EINPRESSTIFT L=6,8 PIN	VL 0010.7250.00	AMP	1-928776-5	
P101	VL EINPRESSTIFT L=6,8 PIN	VL 0010.7250.00	AMP	1-928776-5	
P305	VL EINPRESSTIFT L=6,8 PIN	VL 0010.7250.00	AMP	1-928776-5	
P405	VL EINPRESSTIFT L=6,8 PIN	VL 0010.7250.00	AMP	1-928776-5	
P406	VL EINPRESSTIFT L=6,8 PIN	VL 0010.7250.00	AMP	1-928776-5	
P409	VL EINPRESSTIFT L=6,8 PIN	VL 0010.7250.00	AMP	1-928776-5	
P510	VL EINPRESSTIFT L=6,8 PIN	VL 0010.7250.00	AMP	1-928776-5	
P513	VL EINPRESSTIFT L=6,8 PIN	VL 0010.7250.00	AMP	1-928776-5	
P530	VL EINPRESSTIFT L=6,8 PIN	VL 0010.7250.00	AMP	1-928776-5	
R100	RG 22,1 OHM+-1%TK100 1206 RESISTOR CHIP	RG 0007.5489.00	ROEDERSTEI	DC2 22,10HM 1%TK100	
R101	RG 22,1KOHM+-1%TK100 1206 RESISTOR CHIP	RG 0007.5872.00	ROEDERSTEI	DC2 22,1KOHM 1%TK100	
R102	RS 0,25W10KOHM +-20% SMD POTENTIOMETER	RS 0007.9649.00	BOURNS	3314G-1-103	
R105	RG 20,0KOHM+-1%TK100 1206 RESISTOR CHIP	RG 0007.5866.00	ROEDERSTEI	DC2 20,0KOHM 1%TK100	
R106	RG 1,3 KOHM+-1%TK100 1206 RESISTOR CHIP	RG 0007.5708.00	ROEDERSTEI	DC2 1,3KOHM 1%TK100	
R108	RG 1,0MOHM+-1%TK100 1206 CHIP RESISTOR	RG 0815.7532.00	DRALORIC	CRC 1206	
R109	NUR VAR/ONLY MOD: 02 RL 0,35W20,0KOHM+-0,1%T25 RESISTOR	RL 0084.3641.00	RESISTA	MK2	
R110	RL 0,35W20,0KOHM+-0,1%T25 RESISTOR	RL 0084.3641.00	RESISTA	MK2	
R111	RG 100 OHM+-1%TK100 1206 CHIP RESISTOR	RG 0006.8884.00	ROEDERSTEI	DC2 100OHM 1%TK100	
R112	RG 562 OHM+-1%TK100 1206 CHIP RESISTOR	RG 0006.9068.00	ROEDERSTEI	DC2 562OHM 1%TK100	
R113	RL 0,35W10,0KOHM+-0,1%T25 RESISTOR	RL 0084.3064.00	DRALORIC	SMA0207/10K-B-E	
R114	RL 0,35W10,0KOHM+-0,1%T25 RESISTOR	RL 0084.3064.00	DRALORIC	SMA0207/10K-B-E	
R115	RG 1,0 KO +-1%TK100 1206 CHIP RESISTOR	RG 0006.7271.00	ROEDERSTEI	DC2 1,0KOHM 1%TK100	
R120	RG 10,0KOHM+-1%TK100 1206 RG CHIP RESISTOR	RG 0007.0793.00	ROEDERSTEI	DC2 10,0KOHM 1%TK100	
R130	RG 10,0KOHM+-1%TK100 1206 RG CHIP RESISTOR	RG 0007.0793.00	ROEDERSTEI	DC2 10,0KOHM 1%TK100	
R138	RG 13,0KOHM+-1%TK100 1206 RESISTOR CHIP	RG 0007.5837.00	ROEDERSTEI	DC2 13,0KOHM 1%TK100	
R139	RS 0,25W500 OHM+-20% SMD POTENTIOMETER	RS 0007.9603.00	BOURNS	3314G-1-501	
R140	RG 2,74KOHM+-1%TK100 1206 RESISTOR CHIP	RG 0007.5766.00	ROEDERSTEI	DC2 2,74KOHM 1%TK100	
R141	RG 1,82KOHM+-1%TK100 1206 RESISTOR CHIP	RG 0007.5720.00	ROEDERSTEI	DC2 1,82KOHM 1%TK100	
R142	RG 10,0KOHM+-1%TK100 1206 RG CHIP RESISTOR	RG 0007.0793.00	ROEDERSTEI	DC2 10,0KOHM 1%TK100	
R143	RG 100 OHM+-1%TK100 1206 CHIP RESISTOR	RG 0006.8884.00	ROEDERSTEI	DC2 100OHM 1%TK100	
R144	RG 0-OHM WIDERSTAND-CHIP RESISTOR CHIP 0-OHM	RG 0007.5108.00	DRALORIC	CR 1206	
R145	RG 100 OHM+-1%TK100 1206 CHIP RESISTOR	RG 0006.8884.00	ROEDERSTEI	DC2 100OHM 1%TK100	
R146	RG 10,0KOHM+-1%TK100 1206 RG CHIP RESISTOR	RG 0007.0793.00	ROEDERSTEI	DC2 10,0KOHM 1%TK100	
R147	RG 10,0KOHM+-1%TK100 1206 RG CHIP RESISTOR	RG 0007.0793.00	ROEDERSTEI	DC2 10,0KOHM 1%TK100	
R148	RG 1,0 KO +-1%TK100 1206 CHIP RESISTOR	RG 0006.7271.00	ROEDERSTEI	DC2 1,0KOHM 1%TK100	
R149	RG 0-OHM WIDERSTAND-CHIP RESISTOR CHIP 0-OHM	RG 0007.5108.00	DRALORIC	CR 1206	
R150	RG 10,0KOHM+-1%TK100 1206 RG CHIP RESISTOR	RG 0007.0793.00	ROEDERSTEI	DC2 10,0KOHM 1%TK100	
R151	RG 10,0KOHM+-1%TK100 1206 RG CHIP RESISTOR	RG 0007.0793.00	ROEDERSTEI	DC2 10,0KOHM 1%TK100	

MENP5	413 3PUA	ÄI	Datum Date	Schaltteilliste für Parts list for	Sachnummer Stock No.	Blatt-Nr. Page
		18	16.09.97	ED PROCESSOR PROCESSOR	1062.6309.01 SA	6+

095.0028-0693

Für diese Unterlage behalten wir uns alle Rechte vor.

Kennz. Comp. No.	Benennung Designation	Sachnummer Stock No.	Hersteller Manufacturer	Bezeichnung Designation	enthalten in contained in
R152	RG 10,0KOHM+-1%TK100 1206 RG CHIP RESISTOR	RG 0007.0793.00	ROEDERSTEI	DC2 10,0KOHM 1%TK100	
R153	RG 10,0KOHM+-1%TK100 1206 RG CHIP RESISTOR	RG 0007.0793.00	ROEDERSTEI	DC2 10,0KOHM 1%TK100	
R154	RG 4,75KOHM+-1%TK100 1206 RESISTOR CHIP	RG 0007.5820.00	ROEDERSTEI	DC2 4,75KOHM 1%TK100	
R156	RG 4,75KOHM+-1%TK100 1206 RESISTOR CHIP	RG 0007.5820.00	ROEDERSTEI	DC2 4,75KOHM 1%TK100	
R157	RG 4,75KOHM+-1%TK100 1206 RESISTOR CHIP	RG 0007.5820.00	ROEDERSTEI	DC2 4,75KOHM 1%TK100	
R160	RN 9X 10KOHM+-SIL10 H5 RESISTOR NETWORK	RN 0343.4523.00	BI_TECHNOL	L 10 1 S 103 M*	
R161	RN 9X 10KOHM+-SIL10 H5 RESISTOR NETWORK	RN 0343.4523.00	BI_TECHNOL	L 10 1 S 103 M*	
R163	RN 9X 10KOHM+-SIL10 H5 RESISTOR NETWORK	RN 0343.4523.00	BI_TECHNOL	L 10 1 S 103 M*	
R165	RG 4,75KOHM+-1%TK100 1206 RESISTOR CHIP	RG 0007.5820.00	ROEDERSTEI	DC2 4,75KOHM 1%TK100	
R166	RG 4,75KOHM+-1%TK100 1206 RESISTOR CHIP	RG 0007.5820.00	ROEDERSTEI	DC2 4,75KOHM 1%TK100	
R170	RG 10,0KOHM+-1%TK100 1206 RG CHIP RESISTOR	RG 0007.0793.00	ROEDERSTEI	DC2 10,0KOHM 1%TK100	
R171	RG 10,0KOHM+-1%TK100 1206 RG CHIP RESISTOR	RG 0007.0793.00	ROEDERSTEI	DC2 10,0KOHM 1%TK100	
R172	RG 10,0KOHM+-1%TK100 1206 RG CHIP RESISTOR	RG 0007.0793.00	ROEDERSTEI	DC2 10,0KOHM 1%TK100	
R174	RG 10,0KOHM+-1%TK100 1206 RG CHIP RESISTOR	RG 0007.0793.00	ROEDERSTEI	DC2 10,0KOHM 1%TK100	
..178	RG 1,0 KO +-1%TK100 1206 CHIP RESISTOR	RG 0006.7271.00	ROEDERSTEI	DC2 1,0KOHM 1%TK100	
R179	RG 1,0 KO +-1%TK100 1206 CHIP RESISTOR	RG 0006.7271.00	ROEDERSTEI	DC2 1,0KOHM 1%TK100	
R180	RG 1,0 KO +-1%TK100 1206 CHIP RESISTOR	RG 0006.7271.00	ROEDERSTEI	DC2 1,0KOHM 1%TK100	
R200	RG 0-OHM WIDERSTAND-CHIP RESISTOR CHIP 0-OHM	RG 0007.5108.00	DRALORIC	CR 1206	
R204	RG 2,21KOHM+-1%TK100 1206 RESISTOR CHIP	RG 0007.5743.00	ROEDERSTEI	DC2 2,21KOHM 1%TK100	
R205	RG 10,0KOHM+-1%TK100 1206 RG CHIP RESISTOR	RG 0007.0793.00	ROEDERSTEI	DC2 10,0KOHM 1%TK100	
R220	RG 10,0KOHM+-1%TK100 1206 RG CHIP RESISTOR	RG 0007.0793.00	ROEDERSTEI	DC2 10,0KOHM 1%TK100	
R221	RG 5,62KOHM+-1%TK100 1206 CHIP RESISTOR	RG 0007.0735.00	ROEDERSTEI	DC2 5,62KOHM 1%TK100	
R250	RN 9X 10KOHM+-SIL10 H5 RESISTOR NETWORK	RN 0343.4523.00	BI_TECHNOL	L 10 1 S 103 M*	
R251	RG 6,81KOHM+-1%TK100 1206 CHIP RESISTOR	RG 0007.0758.00	ROEDERSTEI	DC2 6,81KOHM 1%TK100	
R252	RG 1,0 KO +-1%TK100 1206 CHIP RESISTOR	RG 0006.7271.00	ROEDERSTEI	DC2 1,0KOHM 1%TK100	
R301	RG 10,0KOHM+-1%TK100 1206 RG CHIP RESISTOR	RG 0007.0793.00	ROEDERSTEI	DC2 10,0KOHM 1%TK100	
..309	RG 4,75KOHM+-1%TK100 1206 RESISTOR CHIP	RG 0007.5820.00	ROEDERSTEI	DC2 4,75KOHM 1%TK100	
R320	RG 182 KOHM+-1%TK100 1206 RESISTOR CHIP	RG 0007.5989.00	ROEDERSTEI	DC2 182KOHM 1%TK100	
R321	RG 10,0KOHM+-1%TK100 1206 RG CHIP RESISTOR	RG 0007.0793.00	ROEDERSTEI	DC2 10,0KOHM 1%TK100	
R322	RG 10,0KOHM+-1%TK100 1206 RG CHIP RESISTOR	RG 0007.0793.00	ROEDERSTEI	DC2 10,0KOHM 1%TK100	
R323	RG 10,0KOHM+-1%TK100 1206 RG CHIP RESISTOR	RG 0007.0793.00	ROEDERSTEI	DC2 10,0KOHM 1%TK100	
R330	RG 1,0 KO +-1%TK100 1206 CHIP RESISTOR	RG 0006.7271.00	ROEDERSTEI	DC2 1,0KOHM 1%TK100	
..338	RG 10,0KOHM+-1%TK100 1206 RG CHIP RESISTOR	RG 0007.0793.00	ROEDERSTEI	DC2 10,0KOHM 1%TK100	
R340	RG 47,5 OHM+-1%TK100 1206 RESISTOR CHIP	RG 0007.5566.00	ROEDERSTEI	DC2 47,5OHM 1%TK100	
R400	RG 10,0KOHM+-1%TK100 1206 RG CHIP RESISTOR	RG 0007.0793.00	ROEDERSTEI	DC2 10,0KOHM 1%TK100	
R401	RG 10,0KOHM+-1%TK100 1206 RG CHIP RESISTOR	RG 0007.0793.00	ROEDERSTEI	DC2 10,0KOHM 1%TK100	
R402	RG 10,0KOHM+-1%TK100 1206 RG CHIP RESISTOR	RG 0007.0793.00	ROEDERSTEI	DC2 10,0KOHM 1%TK100	
R403	RG 47,5 OHM+-1%TK100 1206 RESISTOR CHIP	RG 0007.5566.00	ROEDERSTEI	DC2 47,5OHM 1%TK100	
R404	RG 47,5 OHM+-1%TK100 1206 RESISTOR CHIP	RG 0007.5566.00	ROEDERSTEI	DC2 47,5OHM 1%TK100	
R405	RG 10,0KOHM+-1%TK100 1206 RG CHIP RESISTOR	RG 0007.0793.00	ROEDERSTEI	DC2 10,0KOHM 1%TK100	
R410	RG 10,0KOHM+-1%TK100 1206 RG CHIP RESISTOR	RG 0007.0793.00	ROEDERSTEI	DC2 10,0KOHM 1%TK100	
R411	RG 10,0KOHM+-1%TK100 1206 RG CHIP RESISTOR	RG 0007.0793.00	ROEDERSTEI	DC2 10,0KOHM 1%TK100	

MENP5

413 3PUA

Äi

Datum
Date

Schaltteilliste für
Parts list for

Sachnummer
Stock No.

Blatt-Nr.
Page



ROHDE & SCHWARZ

18

16.09.97

ED PROCESSOR
PROCESSOR

1062.6309.01 SA

7+

Kennz. Comp. No.	Benennung Designation	Sachnummer Stock No.	Hersteller Manufacturer	Bezeichnung Designation	enthalten in contained in
R412	RG 47,5 OHM+-1%TK100 1206 RESISTOR CHIP	RG 0007.5566.00	ROEDERSTEI	DC2 47,5OHM 1%TK100	
R413	RG 47,5 OHM+-1%TK100 1206 RESISTOR CHIP	RG 0007.5566.00	ROEDERSTEI	DC2 47,5OHM 1%TK100	
R423	RG 10,OKOHM+-1%TK100 1206 RG CHIP RESISTOR	RG 0007.0793.00	ROEDERSTEI	DC2 10,OKOHM 1%TK100	
R424	RG 10,OKOHM+-1%TK100 1206 RG CHIP RESISTOR	RG 0007.0793.00	ROEDERSTEI	DC2 10,OKOHM 1%TK100	
R427	RG 10,OKOHM+-1%TK100 1206 RG CHIP RESISTOR	RG 0007.0793.00	ROEDERSTEI	DC2 10,OKOHM 1%TK100	
R428	RG 10,OKOHM+-1%TK100 1206 RG CHIP RESISTOR	RG 0007.0793.00	ROEDERSTEI	DC2 10,OKOHM 1%TK100	
R430	RG 10,OKOHM+-1%TK100 1206 RG CHIP RESISTOR	RG 0007.0793.00	ROEDERSTEI	DC2 10,OKOHM 1%TK100	
R450	RS 0,25W200 OHM+-20% SMD POTENTIOMETER	RS 0007.9590.00	SIEMENS	S4G-200 OHM	
R451	RG 909 OHM+-1%TK100 1206 CHIP RESISTOR	RG 0006.7265.00	ROEDERSTEI	DC2 909OHM 1%TK100	
R460	RG 221 OHM+-1%TK100 1206 RESISTOR CHIP	RG 0007.5614.00	ROEDERSTEI	DC2 221OHM 1%TK100	
R461	RG 221 OHM+-1%TK100 1206 RESISTOR CHIP	RG 0007.5614.00	ROEDERSTEI	DC2 221OHM 1%TK100	
R462	RG 2,74KOHM+-1%TK100 1206 RESISTOR CHIP	RG 0007.5766.00	ROEDERSTEI	DC2 2,74KOHM 1%TK100	
R463	RG 2,74KOHM+-1%TK100 1206 RESISTOR CHIP	RG 0007.5766.00	ROEDERSTEI	DC2 2,74KOHM 1%TK100	
R469	RG 301 OHM+-1%TK100 1206 RESISTOR CHIP	RG 0007.5643.00	ROEDERSTEI	DC2 301OHM 1%TK100	
R470	RG 47,5 OHM+-1%TK100 1206 RESISTOR CHIP	RG 0007.5566.00	ROEDERSTEI	DC2 47,5OHM 1%TK100	
R471	RG 47,5 OHM+-1%TK100 1206 RESISTOR CHIP	RG 0007.5566.00	ROEDERSTEI	DC2 47,5OHM 1%TK100	
R472	RG 10,OKOHM+-1%TK100 1206 RG CHIP RESISTOR	RG 0007.0793.00	ROEDERSTEI	DC2 10,OKOHM 1%TK100	
R473	RG 10,OKOHM+-1%TK100 1206 RG CHIP RESISTOR	RG 0007.0793.00	ROEDERSTEI	DC2 10,OKOHM 1%TK100	
R474	RG 100 OHM+-1%TK100 1206 CHIP RESISTOR	RG 0006.8884.00	ROEDERSTEI	DC2 100OHM 1%TK100	
R475	RG 301 OHM+-1%TK100 1206 RESISTOR CHIP	RG 0007.5643.00	ROEDERSTEI	DC2 301OHM 1%TK100	
R480	RG 332 OHM+-1%TK100 1206 RESISTOR CHIP	RG 0007.5650.00	ROEDERSTEI	DC2 332OHM 1%TK100	
R481	RG 243 OHM+-1%TK100 1206 RESISTOR CHIP	RG 0007.5620.00	ROEDERSTEI	DC2 243OHM 1%TK100	
R482	RG 681 OHM+-1%TK100 1206 CHIP RESISTOR	RG 0006.9080.00	ROEDERSTEI	DC2 681OHM 1%TK100	
R485	RG 10,OKOHM+-1%TK100 1206 RG CHIP RESISTOR	RG 0007.0793.00	ROEDERSTEI	DC2 10,OKOHM 1%TK100	
R486	RG 10,OKOHM+-1%TK100 1206 RG CHIP RESISTOR	RG 0007.0793.00	ROEDERSTEI	DC2 10,OKOHM 1%TK100	
R490	RG 1,0 KO +-1%TK100 1206 CHIP RESISTOR	RG 0006.7271.00	ROEDERSTEI	DC2 1,0KOHM 1%TK100	
R491	RG 1,82KOHM+-1%TK100 1206 RESISTOR CHIP	RG 0007.5720.00	ROEDERSTEI	DC2 1,82KOHM 1%TK100	
R500	RL 0,35W1,10KOHM+-0,1%T25 RESISTOR	RL 0083.9223.00	DRALORIC	SMA0207	
R504	RL 0,35W1,10KOHM+-0,1%T25 RESISTOR	RL 0083.9223.00	DRALORIC	SMA0207	
R505	RG 4,75KOHM+-1%TK100 1206 RESISTOR CHIP	RG 0007.5820.00	ROEDERSTEI	DC2 4,75KOHM 1%TK100	
R505	NUR VAR/ONLY MOD: 02 RG 10,OKOHM+-1%TK100 1206 RG CHIP RESISTOR	RG 0007.0793.00	ROEDERSTEI	DC2 10,OKOHM 1%TK100	
R506	NUR VAR/ONLY MOD: 04 RG 200 KOHM+-1%TK100 1206 RESISTOR CHIP	RG 0007.5995.00	ROEDERSTEI	DC2 200KOHM 1%TK100	
R515	RG 4,75KOHM+-1%TK100 1206 RESISTOR CHIP	RG 0007.5820.00	ROEDERSTEI	DC2 4,75KOHM 1%TK100	
R515	NUR VAR/ONLY MOD: 02 RG 18,2KOHM+-1%TK100 1206 RESISTOR CHIP	RG 0007.5850.00	ROEDERSTEI	DC2 18,2KOHM 1%TK100	
R520	NUR VAR/ONLY MOD: 04 RS 0,25W 2MOHM +-20% SMD POTENTIOMETER	RS 0007.9710.00	SIEMENS	S4G-2MOHM	
R529	RG 1,0 KO +-1%TK100 1206 CHIP RESISTOR	RG 0006.7271.00	ROEDERSTEI	DC2 1,0KOHM 1%TK100	
	NUR VAR/ONLY MOD: 02				

Für diese Unterlage behalten wir uns alle Rechte vor.

095.0028-0893

MENP5	413 3PUA	Äi	Datum Date	Schaltteilliste für Parts list for	Sachnummer Stock No.	Blatt-Nr. Page
 ROHDE & SCHWARZ	18		16.09.97	ED PROCESSOR PROCESSOR	1062.6309.01 SA	8+

Für diese Unterlage behalten
wir uns alle Rechte vor.

Kennz. Comp. No.	Benennung Designation	Sachnummer Stock No.	Hersteller Manufacturer	Bezeichnung Designation	enthalten in contained in
R529	RG 100 OHM+-1%TK100 1206 CHIP RESISTOR NUR VAR/ONLY MOD: 04	RG 0006.8884.00	ROEDERSTEI	DC2 100OHM 1%TK100	
R530	RG 4,75OHM+-1%TK100 1206 CHIP-RESISTOR NUR VAR/ONLY MOD: 02	RG 0007.8420.00	PHILIPS	RC 02	
R530	RG 0-OHM WIDERSTAND-CHIP RESISTOR CHIP 0-OHM NUR VAR/ONLY MOD: 04	RG 0007.5108.00	DRALORIC	CR 1206	
R531	RG 4,75OHM+-1%TK100 1206 CHIP-RESISTOR NUR VAR/ONLY MOD: 02	RG 0007.8420.00	PHILIPS	RC 02	
R531	RG 0-OHM WIDERSTAND-CHIP RESISTOR CHIP 0-OHM NUR VAR/ONLY MOD: 04	RG 0007.5108.00	DRALORIC	CR 1206	
R532	RG 4,75OHM+-1%TK100 1206 CHIP-RESISTOR	RG 0007.8420.00	PHILIPS	RC 02	
R533	RG 4,75OHM+-1%TK100 1206 CHIP-RESISTOR	RG 0007.8420.00	PHILIPS	RC 02	
R534	RG 1,0 KO +-1%TK100 1206 CHIP RESISTOR NUR VAR/ONLY MOD: 02	RG 0006.7271.00	ROEDERSTEI	DC2 1,0KOHM 1%TK100	
R534	RG 619 OHM+-1%TK100 1206 CHIP RESISTOR NUR VAR/ONLY MOD: 04	RG 0006.9074.00	ROEDERSTEI	DC2 619OHM 1%TK100	
R538	RG 1,0 KO +-1%TK100 1206 CHIP RESISTOR	RG 0006.7271.00	ROEDERSTEI	DC2 1,0KOHM 1%TK100	
R540	RG 110,0KOH+-1%TK100 1206 CHIP RESISTOR	RG 0007.1954.00	ROEDERSTEI	DC2 110KOHM 1%TK100	
R541	RG 0-OHM WIDERSTAND-CHIP RESISTOR CHIP 0-OHM	RG 0007.5108.00	DRALORIC	CR 1206	
R542	RG 475 OHM+-1%TK100 1206 RESISTOR CHIP	RG 0007.5695.00	ROEDERSTEI	DC2 475OHM 1%TK100	
R543	RG 619 OHM+-1%TK100 1206 CHIP RESISTOR	RG 0006.9074.00	ROEDERSTEI	DC2 619OHM 1%TK100	
R544	RG 1,0MOHM+-1%TK100 1206 CHIP RESISTOR NUR VAR/ONLY MOD: 02	RG 0815.7532.00	DRALORIC	CRC 1206	
R545	RG 100,0KOH+-1%TK100 1206 CHIP RESISTOR	RG 0007.1948.00	ROEDERSTEI	DC2 100KOHM 1%TK100	
R546	RL 0,60W 10,0 OHM+-1%TK50 RESISTOR NUR VAR/ONLY MOD: 02	RL 0082.8852.00	RESISTA	MK2	
R547	RL 0,35W33,6KOHM+-0,1%T25 RESISTOR NUR VAR/ONLY MOD: 02	RL 0084.4077.00	RESISTA	MK2	
R547	RL 0,35W32,0KOHM+-0,1%T25 RESISTOR NUR VAR/ONLY MOD: 04	RL 0084.4031.00	RESISTA	MK2	
R548	RL 0,35W221 OHM+-0,1%TK25 RESISTOR NUR VAR/ONLY MOD: 04	RL 0083.7889.00	RESISTA	MK2	
R548	RL 0,35W158 OHM+-0,1%TK25 RESISTOR NUR VAR/ONLY MOD: 02	RL 0083.7608.00	RESISTA	MK2	
R549	RL 0,25W3,83KOHM+-0,1%T25 RESISTOR NUR VAR/ONLY MOD: 02	RL 0084.2268.00	DRALORIC	SMA/207/3,83K-B-E	
R549	RL 0,35W5,42KOHM+-0,1%T25 RESISTOR NUR VAR/ONLY MOD: 04	RL 0084.2551.00	RESISTA	MK2	
R550	RS 0,25W 5KOHM +-20% SMD POTENTIOMETER	RS 0007.9632.00	SIEMENS	S4G-5KOHM	
R551	RG 5,62KOHM+-1%TK100 1206 CHIP RESISTOR	RG 0007.0735.00	ROEDERSTEI	DC2 5,62KOHM 1%TK100	
R552	RG 5,62KOHM+-1%TK100 1206 CHIP RESISTOR	RG 0007.0735.00	ROEDERSTEI	DC2 5,62KOHM 1%TK100	
R553	RG 681 OHM+-1%TK100 1206 CHIP RESISTOR	RG 0006.9080.00	ROEDERSTEI	DC2 681OHM 1%TK100	
R555	RG 2,0 KOHM+-1%TK100 1206 RESISTOR CHIP	RG 0007.5737.00	ROEDERSTEI	DC2 2,0KOHM 1%TK100	
R556	RG 2,0 KOHM+-1%TK100 1206 RESISTOR CHIP	RG 0007.5737.00	ROEDERSTEI	DC2 2,0KOHM 1%TK100	
R557	RG 10,0KOHM+-1%TK100 1206 RG CHIP RESISTOR	RG 0007.0793.00	ROEDERSTEI	DC2 10,0KOHM 1%TK100	
R558	RG 10,0KOHM+-1%TK100 1206 RG CHIP RESISTOR	RG 0007.0793.00	ROEDERSTEI	DC2 10,0KOHM 1%TK100	

MENP5	413 3PUA	Äl	Datum Date	Schaltteilliste für Parts list for	Sachnummer Stock No.	Blatt-Nr. Page
	ROHDE & SCHWARZ	18	16.09.97	ED PROCESSOR PROCESSOR	1062.6309.01 SA	9+

095.0028-0893

Kennz. Comp. No.	Benennung Designation	Sachnummer Stock No.	Hersteller Manufacturer	Bezeichnung Designation	enthalten in contained in
R559	RG 274 KOHM+-1%TK100 1206 RESISTOR CHIP	RG 0007.4460.00	ROEDERSTEI	DC2 274KOHM 1%TK100	
R560	RG 274 KOHM+-1%TK100 1206 RESISTOR CHIP	RG 0007.4460.00	ROEDERSTEI	DC2 274KOHM 1%TK100	
R561	RG 4,02KOH+-0,1%TK25 1206 SMD-RESISTOR EIA1206	0009.7814.00	MIKRO-TEK-	CMF 1206	
R564	RG 33,2 OHM+-1%TK100 1206 RESISTOR CHIP	RG 0007.5520.00	ROEDERSTEI	DC2 33,2OHM 1%TK100	
R566	RG 4,02KOH+-0,1%TK25 1206 SMD-RESISTOR EIA1206	0009.7814.00	MIKRO-TEK-	CMF 1206	
R567	RG 4,75OHM+-1%TK100 1206 CHIP-RESISTOR	RG 0007.8420.00	PHILIPS	RC 02	
R568	RG 4,75OHM+-1%TK100 1206 CHIP-RESISTOR	RG 0007.8420.00	PHILIPS	RC 02	
R570	RG 10,0KOHM+-1%TK100 1206 RG CHIP RESISTOR	RG 0007.0793.00	ROEDERSTEI	DC2 10,0KOHM 1%TK100	
R571	RG 1,0 KO +-1%TK100 1206 CHIP RESISTOR	RG 0006.7271.00	ROEDERSTEI	DC2 1,0KOHM 1%TK100	
R572	RG 1,0 KO +-1%TK100 1206 CHIP RESISTOR	RG 0006.7271.00	ROEDERSTEI	DC2 1,0KOHM 1%TK100	
R575	RG 4,02KOH+-0,1%TK25 1206 SMD-RESISTOR EIA1206	0009.7814.00	MIKRO-TEK-	CMF 1206	
R576	RG 4,02KOH+-0,1%TK25 1206 SMD-RESISTOR EIA1206	0009.7814.00	MIKRO-TEK-	CMF 1206	
R577	RG 4,02KOH+-0,1%TK25 1206 SMD-RESISTOR EIA1206	0009.7814.00	MIKRO-TEK-	CMF 1206	
V110	AE BZV55/C5V6 0.5W ZDI ZENER DIODE	AE 0006.9845.00	PHILIPS	BZV55B5V6	
V120	AD BAV99 70V DUO UDI DIODE	AD 0911.0092.00	VALVO	BAV99	
V205	AD BAS32 75V UDI DIODE	AD 0006.7288.00	PHILIPS	BAS32 (L)	
V210	AK BC850B N 45V 200MA TRANSISTOR	AK 0007.7969.00	VALVO	BC850B	
V220	AK BC850B N 45V 200MA TRANSISTOR	AK 0007.7969.00	VALVO	BC850B	
V462	AE BZV55/C12 0,5W ZDI ZENER DIODE	AE 0006.9897.00	PHILIPS_SE	BZV55B12	
V463	AE BZV55/C6V8 0,5W ZDI ZENER DIODE	AE 0006.9868.00	PHILIPS	BZV55/B6V8	
V470	AK BSR18 P 40V 200MA TRANSISTOR	AK 0007.2073.00	PHILIPS_SE	BSR18 (BSR18A)	
V471	AE HSMS2800 SCHOTTKY DIODE	AE 0836.8421.00	HEWLETT_PA	HSMS-2800	
V475	AK BSR13 N 30V 800MA TRANSISTOR	AK 0007.2209.00	VALVO	BSR 13	
V476	AE HSMS2800 SCHOTTKY DIODE	AE 0836.8421.00	HEWLETT_PA	HSMS-2800	
V480	AM SD210DE N-E 30V MOSF MOS-FET	0844.7637.00	SILICONIX	SD210DE	
V540	AD BAV99 70V DUO UDI DIODE	AD 0911.0092.00	VALVO	BAV99	
V550	AE BZV55/C5V6 0.5W ZDI ZENER DIODE	AE 0006.9845.00	PHILIPS	BZV55B5V6	
V551	AE BZV55/C4V7 0.5W ZDI ZENER DIODE	AE 0006.9822.00	PHILIPS	BZV55B4V7	
X1	FP STECKERLEISTE 26P.GER CONNECTOR 26P.	FP 0820.8610.00	SIEMENS	V23535-A2200-A262	
X2	FP STECKERLEISTE 26P.GER CONNECTOR 26P.	FP 0820.8610.00	SIEMENS	V23535-A2200-A262	
X3	FP STECKERLEISTE 34P.GER CONNECTOR 34P	FP 0351.3474.00	SIEMENS	V23535-A2200-A342	
X104	FP STIFTELEISTE 36P.R2,54 PIN CONNECTOR 2-POLIG/2 PINS	FP 0242.3600.00	BINDER	742-11-0179-00-36	
X108	VL STECKLOETOESE 7,5X1,1 PLUG-IN SOLDERING LUG	VL 0078.2747.00	-	R&S-ZCHNG.078.2747	
X109	VL STECKLOETOESE 7,5X1,1 PLUG-IN SOLDERING LUG	VL 0078.2747.00	-	R&S-ZCHNG.078.2747	
X225	FP STIFTELEISTE 36P.R2,54 PIN CONNECTOR 2-POLIG/2 PINS	FP 0242.3600.00	BINDER	742-11-0179-00-36	
X401	FP STIFTELEISTE 36P.R2,54 PIN CONNECTOR 2-POLIG/2 PINS	FP 0242.3600.00	BINDER	742-11-0179-00-36	

Für diese Unterlage benennen wir uns alle Rechte vor.

095.0028-0693

MENP5	413 3PUA	AI	Datum Date	Schalttafeliste für Parts list for	Sachnummer Stock No.	Blatt-Nr. Page
	18	16.09.97	ED PROCESSOR PROCESSOR	1062.6309.01 SA	10+	

Für diese Unterlage behalten wir uns alle Rechte vor.

Kennz. Comp. No.	Benennung Designation	Sachnummer Stock No.	Hersteller Manufacturer	Bezeichnung Designation	enthalten in contained in	
X501	FP STIFTL. WIN 36P. R2, 54 ANGLE PIN CONNECTOR	FP 0243.3578.00	BINDER	742-5-11-0187-00-36		
MENP5	413 3PUA	AI	Datum Date	Schaltteilliste für Parts list for	Sachnummer Stock No.	Blatt-Nr. Page
 ROHDE & SCHWARZ	18	16.09.97	ED PROCESSOR PROCESSOR	1062.6309.01 SA	11-	

XY-Liste

XY List

Erklärung der Spaltenbezeichnungen:

- Part:** Bauelement-Kennzeichen.
- Side:** Leiterplatten-Seite, auf der sich das Bauelement befindet.
- X/Y:** Koordinaten (Millimeter) des Bauelementes auf der Leiterplatte bezogen auf den Nullpunkt.
- SQR, PG:** Planquadrat und Seite des Schaltbildes für das jeweilige Bauelement.

Explanation of column designations:

- Part:** Identification of instrument part.
- Side:** Side of the PC board on which instrument part is positioned.
- X/Y:** Coordinates (millimeter) of the component on the PC board in reference to zero point.
- SQR, PG:** Square and page of the diagram for the respective instrument part.

14m+

Service-Relevante Bauteile / Service-Relevant Components

Part	Side	X	Y	Sqr	Pg	Part	Side	X	Y	Sqr	Pg	Part	Side	X	Y	Sqr	Pg
P100	B	172	51	4E	2	R102	B	184	60	4E	2	X104	B	158	69	5F	2
P100	B	172	51	3E	1	R102	B	184	60	3F	1	X104	B	158	69	5F	1
P101	B	175	34	5F	2	R139	B	90	75	3C	2	X108	B	25	92	3C	2
P101	B	175	34	3F	1	R139	B	90	75	3C	1	X108	B	25	92	3C	1
P305	B	31	46	8E	4	R450	B	272	73	8D	5	X109	B	25	57	3B	2
P405	B	266	71	8E	5	R520	B	286	41	7E	6	X109	B	25	57	3B	1
P406	B	264	71	8F	5	R550	B	248	23	4B	6	X225	B	44	53	8D	3
P409	B	261	71	11D	5	X1	B	51	8	2E	4	X401	B	199	108	4E	5
P510	B	298	53	6E	6	X2	B	83	107	11D	3	X501	B	190	10	1D	6
P513	B	246	28	3C	6	X3	B	114	8	11B	2						
P530	B	287	36	8E	6	X3	B	114	8	2A	1						

ROHDE & SCHWARZ	-I	Datum Date	XY-Liste für XY-list for	Sach-Nummer Stock-Nr	Blatt Page
	02	02.11.93	ED RECHNER PROCESSOR	1062.6309.01 XY	1+



Nicht-Service-Relevante Bauteile / Non-Service-Relevant Components

Part	Side	X	Y	Sqr	Pg	Part	Side	X	Y	Sqr	Pg	Part	Side	X	Y	Sqr	Pg
B100	B	158	67	5F	2	C174	B	136	19	11C	2	C327	A	86	23	3C	4
B100	B	158	67	5F	1	C174	B	136	19	11C	1	C330	B	72	20	3C	4
B401	B	199	88	3E	5	C185	A	182	48	6A	2	C331	B	74	20	3C	4
C10	B	97	30	2B	2	C185	A	182	48	6A	1	C332	B	77	20	3C	4
C10	B	97	30	2B	1	C186	A	178	39	6A	2	C333	B	79	20	3C	4
C100	A	116	19	2E	2	C186	A	178	39	6A	1	C334	B	82	20	3C	4
C100	A	116	19	2E	1	C187	A	106	31	8A	2	C340	B	14	31	7E	4
C110	A	110	19	2D	2	C187	A	106	31	8A	1	C400	B	206	70	3D	5
C110	A	110	19	2D	1	C188	A	138	66	8A	2	C402	B	194	79	2E	5
C111	A	182	40	2E	2	C188	A	138	66	8A	1	C404	B	202	77	2D	5
C111	A	182	40	2E	1	C189	A	154	38	7A	2	C406	B	211	76	2D	5
C112	B	171	27	2B	2	C189	A	154	38	7A	1	C409	A	225	73	4A	5
C112	B	171	27	2B	1	C190	A	114	57	6A	2	C417	B	212	70	3C	5
C113	B	180	27	2A	2	C190	A	114	57	6A	1	C418	B	201	46	3C	5
C113	B	180	27	2A	1	C191	A	114	104	7A	2	C419	B	199	50	3B	5
C114	A	114	25	3D	2	C191	A	114	104	7A	1	C420	B	204	99	5A	5
C114	A	114	25	3D	1	C200	A	109	78	2A	3	C421	B	201	40	3B	5
C115	A	172	46	5A	2	C201	A	87	88	4A	3	C430	A	229	103	6A	5
C116	A	163	43	5A	2	C203	A	38	68	6A	3	C440	A	230	91	7A	5
C117	A	172	39	5A	2	C204	B	73	84	6A	3	C449	A	196	92	3F	5
C118	A	184	43	3E	2	C205	A	93	84	5D	3	C450	B	258	98	7E	5
C119	B	171	69	4E	2	C210	A	80	77	7A	3	C451	B	263	76	7D	5
C120	A	140	19	2C	2	C211	A	88	39	8A	3	C452	B	276	82	7A	5
C120	A	140	19	2C	1	C220	A	54	65	7E	3	C453	B	264	85	8A	5
C121	A	140	22	3C	2	C230	B	139	36	2E	3	C454	B	264	79	8E	5
C121	A	140	22	3C	1	C231	B	139	34	2E	3	C460	B	275	79	8E	5
C122	A	153	19	3C	2	C232	B	140	27	2E	3	C461	B	283	76	8D	5
C122	A	153	19	3C	1	C233	B	133	36	2E	3	C472	A	293	72	10C	5
C123	A	153	22	3C	2	C234	B	133	34	2E	3	C473	B	286	90	10E	5
C123	A	153	22	3C	1	C235	A	105	22	2D	3	C474	A	300	75	9C	5
C125	A	180	57	4F	2	C236	A	105	25	2D	3	C475	B	280	93	9E	5
C139	A	123	22	2C	2	C301	B	100	11	3E	4	C480	B	258	88	10D	5
C139	A	123	22	2C	1	C302	B	98	11	3E	4	C481	B	258	81	10D	5
C140	A	159	82	5E	2	C303	A	101	20	3E	4	C485	B	297	76	10D	5
C140	A	159	82	5E	1	C304	A	95	20	3D	4	C490	B	261	101	11E	5
C141	A	156	79	6E	2	C305	A	95	22	3D	4	C492	B	277	90	8A	5
C141	A	156	79	6E	1	C306	A	95	25	3D	4	C493	B	266	88	8A	5
C143	B	93	36	6F	2	C307	B	95	11	3D	4	C500	B	246	55	3E	6
C143	B	93	36	6F	1	C308	B	67	23	3D	4	C501	B	258	55	4E	6
C144	B	120	32	6F	2	C310	A	74	27	1A	4	C502	B	271	55	4E	6
C144	B	120	32	6F	1	C311	A	57	39	2A	4	C503	B	283	55	5E	6
C145	B	128	32	6F	2	C312	A	44	26	3A	4	C504	B	295	55	5E	6
C145	B	128	32	6F	1	C313	A	51	48	4A	4	C505	A	282	36	7E	6
C146	A	161	74	6F	2	C314	B	82	49	5A	4	C506	B	279	33	8D	6
C146	A	161	74	6F	1	C315	A	23	47	6A	4	C510	B	289	40	7E	6
C150	A	132	104	9E	2	C316	A	23	37	7A	4	C530	A	297	20	11E	6
C150	A	132	104	9E	1	C320	B	62	23	3D	4	C531	B	292	8	11E	6
C170	A	111	11	10B	2	C321	A	62	20	3D	4	C532	A	283	20	11E	6
C170	A	111	11	10B	1	C322	B	64	23	3D	4	C533	B	275	8	11E	6
C171	A	120	22	10B	2	C323	B	69	23	3C	4	C537	B	232	34	4C	6
C171	A	120	22	10B	1	C324	A	69	20	3C	4	C538	B	225	33	4D	6
C173	B	136	24	11C	2	C325	A	76	23	3C	4	C539	B	204	25	2C	6
C173	B	136	24	11C	1	C326	A	76	20	3C	4	C540	B	201	19	2C	6

ROHDE & SCHWARZ	-I	Datum Date	XY-Liste für XY-list for	Sach-Nummer Stock-Nr	Blatt Page
		02 02.11.93	ED RECHNER PROCESSOR	1062.6309.01 XY	2+

Part	Side	X	Y	Sqr	Pg	Part	Side	X	Y	Sqr	Pg	Part	Side	X	Y	Sqr	Pg
C541	B	300	30	9E	6	D135-A B	156	37	8B	1	D440-A B	224	103	5D	5		
C542	B	233	29	4C	6	D135-B			9B	1	D440-B			6A	5		
C543	B	241	29	4C	6	D135-C			8B	1	D450	B 241	102	7D	5		
C555	B	220	46	6C	6	D135-D			9B	1	D500-A B	201	33	3D	6		
C556	B	205	36	6B	6	D135-G			7A	1	D500-B			7A	6		
C567	A	266	20	11C	6	D150-A B	112	31	10E	2	D510-A B	286	27	8E	6		
C568	B	260	11	11C	6	D150-B			8A	2	D510-B			7A	6		
C575	A	253	28	3B	6	D150-A B	112	31	10E	1	D545-A B	210	46	6C	6		
C578	A	261	24	2A	6	D150-B			8A	1	D545-B			6B	6		
C579	A	267	24	2A	6	D160-A B	127	67	10D	2	D545-C			4A	6		
C580	A	222	33	1A	6	D160-B			8A	2	D550-A B	261	43	7D	6		
C581	A	216	33	1A	6	D160-A B	127	67	10D	1	D550-B			8C	6		
C582	A	298	30	3A	6	D160-B			8A	1	D550-C			8D	6		
C583	A	291	30	3A	6	D206-A B	110	78	3D	3	D550-D			7C	6		
C584	A	291	40	4A	6	D206-B			2A	3	D550-E			6A	6		
C585	A	301	44	4A	6	D210-A B	109	54	5D	3	D555-A B	243	44	7C	6		
C586	A	213	41	4A	6	D210-B			4A	3	D555-B			5A	6		
C587	A	246	41	5A	6	D230-A B	97	39	6D	3	G100	B 25	92	3B	2		
C588	B	211	53	2B	6	D230-B			7A	3	G100	B 25	92	3B	1		
C589	B	203	53	2B	6	D250-A B	37	56	8D	3	L10	B 89	22	2B	2		
C590	A	267	44	6A	6	D250-B			5A	3	L10	B 89	22	2B	1		
C591	A	267	37	6A	6	D255-A B	69	92	10D	3	L12	B 171	18	2B	2		
C592	A	261	36	6A	6	D255-B			6A	3	L12	B 171	18	2B	1		
C593	A	201	33	6A	6	D260-A B	80	82	10E	3	L13	B 176	21	2A	2		
C594	A	207	29	7A	6	D260-B			7A	3	L13	B 176	21	2A	1		
C595	A	203	33	6A	6	D301-A B	64	39	10C	4	L140	B 130	28	6F	2		
C596	A	286	27	7A	6	D301-B			2A	4	L140	B 130	28	6F	1		
C597	A	279	30	8A	6	D302-A B	49	24	5C	4	L401	B 190	80	2E	5		
C598	A	283	30	7A	6	D302-B			3A	4	L403	B 191	74	2D	5		
C599	B	224	53	2B	6	D303-A B	41	50	8D	4	L405	B 199	70	2D	5		
D10A	B	160	74	6E	2	D303-B			8C	4	L472	B 293	72	9C	5		
D10A	B	160	74			D303-C			4A	4	L473	B 283	93	9E	5		
D10A	B	160	74	6E	1	D304-A B	20	50	7D	4	L500	B 246	52	3E	6		
D100	B	87	89	3B	2	D304-B			7D	4	L501	B 259	52	4E	6		
D100	B	87	89	3B	1	D304-C			6A	4	L502	B 272	52	4E	6		
D105-A	B	174	41	2F	2	D305-A B	20	39	8A	4	L503	B 284	52	5E	6		
D105-B				5A	2	D305-B			7E	4	L590	B 201	60	2B	6		
D107	B	173	54	4F	2	D305-C			6A	4	L591	B 211	60	2B	6		
D110	B	128	104	8E	2	D311-A B	81	27	5E	4	L592	B 218	60	2B	6		
D110	B	128	104	8E	1	D311-B			1A	4	N100-A B	178	45	2E	2		
D120-A	B	124	55	8D	2	D323-A B	68	50	6E	4	N100-B			3E	2		
D120-B				6A	2	D323-B			11C	4	N100-C			6A	2		
D120-A	B	124	55	8D	1	D323-C			5A	4	N100-A B	178	45	4E	1		
D120-B				6A	1	D402-A B	230	71	3D	5	N100-B			3E	1		
D125-B	B	110	107	7A	2	D402-B			3A	5	N100-C			6A	1		
D125-A	B	110	107	5B	2	D402-C			3A	5	N450-A B	267	86	8D	5		
D125-A	B	110	107	5B	1	D402-D			3A	5	N450-B			7A	5		
D125-B				7A	1	D402-E			4A	5	N490-A B	269	92	11D	5		
D135-E	B	156	37	9E	3	D403-A B	217	82	3D	5	N490-B			8A	5		
D135-F				8C	4	D403-B			2A	5	N510-A B	216	33	3D	6		
D135-G	B	156	37	7A	2	D403-C			1A	5	N510-B			1A	6		
D135-A	B	156	37	8B	2	D420-A B	217	92	4D	5	N520-A B	298	40	7E	6		
D135-B				9B	2	D420-B			5A	5	N520-B			4A	6		
D135-C				8B	2	D430-A B	224	91	5E	5	N530-A B	267	24	9C	6		
D135-D				9B	2	D430-B			6A	5	N530-B			10C	6		

ROHDE & SCHWARZ	-I	Datum Date	XY-Liste für XY-list for	Sach-Nummer Stock-Nr	Blatt Page
	02	02.11.93	ED RECHNER PROCESSOR	1062.6309.01 XY	3+

Part	Side	X	Y	Sqr	Pg	Part	Side	X	Y	Sqr	Pg	Part	Side	X	Y	Sqr	Pg
N530-C				2A	6	R135	B	180	66	5D	2	R160-I				9D	1
N540-A	B	291	30	9E	6	R135	B	180	66	5D	1	R161-A	B	131	50	9C	2
N540-B				2A	6	R136	B	178	66	5D	2	R161-B				9C	2
N544-A	B	237	37	4C	6	R136	B	178	66	5D	1	R161-C				9C	2
N544-B				4B	6	R138	A	126	25	2C	2	R161-D				9C	2
N544-C				3A	6	R138	A	126	25	2C	1	R161-E				9D	2
R100	A	180	59	4F	2	R140	A	91	74	3C	2	R161-F				9D	2
R100	A	180	59	2F	1	R140	A	91	74	3C	1	R161-G				9D	2
R101	A	178	64	4E	2	R141	A	97	92	4C	2	R161-H				9D	2
R101	A	178	64	2F	1	R141	A	97	92	4C	1	R161-A	B	131	50	9C	1
R105	A	175	46	2E	2	R142	B	181	83	4C	2	R161-B				9C	1
R105	A	175	46	4F	1	R142	B	181	83	4C	1	R161-C				9C	1
R106	B	169	35	3F	2	R143	A	110	104	5B	2	R161-D				9C	1
R106	B	169	35	4E	1	R143	A	110	104	5B	1	R161-E				9D	1
R108	B	158	23	2E	2	R144	A	117	103	5B	2	R161-F				9D	1
R108	B	158	23	4E	1	R144	A	117	103	5B	1	R161-G				9D	1
R109	B	175	49	3E	2	R145	B	161	104	6C	2	R161-H				9D	1
R110	B	185	36	3E	2	R145	B	161	104	6C	1	R163-A	B	131	48	10D	2
R110	B	185	36	3E	1	R146	B	177	94	7C	2	R163-B				10D	2
R111	A	123	19	2E	2	R146	B	177	94	7C	1	R163-C				10D	2
R111	A	123	19	3E	1	R147	B	150	107	7F	2	R163-D				10D	2
R112	A	114	22	2D	2	R147	B	150	107	7F	1	R163-E				10D	2
R112	A	114	22	2D	1	R148	A	163	82	6F	2	R163-F				10D	2
R113	B	175	39	3D	2	R148	A	163	82	6F	1	R163-G				10D	2
R113	B	175	39	3E	1	R149	B	181	81	6F	2	R163-H				10D	2
R114	B	185	51	3E	2	R149	B	181	81	6F	1	R163-A	B	131	48	10D	1
R114	B	185	51	3E	1	R150	B	154	104	8F	2	R163-B				10D	1
R115	B	168	66	4E	2	R150	B	154	104	8F	1	R163-C				10D	1
R115	B	168	66	3E	1	R151	A	151	79	8F	2	R163-D				10D	1
R120	B	144	19	4D	2	R151	A	151	79	8F	1	R163-E				10D	1
R120	B	144	19	4D	1	R152	B	138	105	8D	2	R163-F				10D	1
R121	B	144	22	4D	2	R152	B	138	105	8D	1	R163-G				10D	1
R121	B	144	22	4D	1	R153	A	125	102	8F	2	R163-H				10D	1
R122	B	149	19	4D	2	R153	A	125	102	8F	1	R165	A	112	36	10E	2
R122	B	149	19	4D	1	R154	B	138	77	9E	2	R165	A	112	36	10E	1
R123	B	149	22	4D	2	R154	B	138	77	9E	1	R166	A	128	62	10D	2
R123	B	149	22	4D	1	R156	B	138	81	9E	2	R166	A	128	62	10D	1
R124	B	164	104	4D	2	R156	B	138	81	9E	1	R170	B	156	104	5C	2
R124	B	164	104	4D	1	R157	A	128	56	8D	2	R170	B	156	104	5C	1
R125	A	165	94	4D	2	R157	A	128	56	8D	1	R171	A	163	94	5C	2
R125	A	165	94	4D	1	R160-A	B	125	76	9D	2	R171	A	163	94	5C	1
R126	B	166	104	4D	2	R160-B				9D	2	R172	A	155	94	5C	2
R126	B	166	104	4D	1	R160-C				9D	2	R172	A	155	94	5C	1
R127	A	111	25	4D	2	R160-D				9D	2	R174	B	169	104	5C	2
R127	A	111	25	4D	1	R160-F				9D	2	R174	B	169	104	5C	1
R130	A	165	82	5E	2	R160-G				9D	2	R175	B	177	88	7B	2
R130	A	165	82	5E	1	R160-H				9D	2	R175	B	177	88	7B	1
R131	A	168	82	5E	2	R160-I				9D	2	R176	B	177	86	7B	2
R131	A	168	82	5E	1	R160-A	B	125	76	9D	1	R176	B	177	86	7B	1
R132	B	166	66	5E	2	R160-B				9D	1	R177	B	133	27	11C	2
R132	B	166	66	5E	1	R160-C				9D	1	R177	B	133	27	11C	1
R133	B	181	76	5E	2	R160-D				9D	1	R178	B	133	22	11C	2
R133	B	181	76	5E	1	R160-F				9D	1	R178	B	133	22	11C	1
R134	B	181	73	5E	2	R160-G				9D	1	R179	B	163	69	6C	2
R134	B	181	73	5E	1	R160-H				9D	1	R179	B	163	69	6C	1

ROHDE & SCHWARZ	-I	Datum Date	XY-Liste für XY-list for	Sach-Nummer Stock-Nr	Blatt Page
		02 02.11.93	ED RECHNER PROCESSOR	1062.6309.01 XY	4+

Part	Side	X	Y	Sqr	Pg	Part	Side	X	Y	Sqr	Pg	Part	Side	X	Y	Sqr	Pg
R180	A	154	79	6C	2	R404	B	189	45	2B	5	R543	A	190	4	1C	6
R180	A	154	79	6C	1	R405	B	232	80	2A	5	R544	B	215	25	3C	6
R200	A	112	85	3C	3	R410	B	205	87	2A	5	R545	B	228	33	4C	6
R201	A	112	83	3C	3	R411	B	208	87	2A	5	R546	B	223	22	4C	6
R204	A	88	74	5E	3	R412	B	192	57	2C	5	R547	B	236	22	4C	6
R205	A	91	84	5E	3	R413	B	189	48	2C	5	R548	B	236	25	4B	6
R220	A	54	63	7D	3	R423	B	220	108	4D	5	R549	B	223	25	4B	6
R221	A	43	63	7E	3	R424	B	204	90	4D	5	R551	A	212	44	5C	6
R250-A	B	62	53	7D	3	R427	B	224	108	4C	5	R552	B	223	39	5B	6
R250-B				7D	3	R428	B	204	105	4C	5	R553	B	253	28	3B	6
R250-C				7D	3	R430	B	227	105	5D	5	R555	A	208	43	5C	6
R250-D				7D	3	R451	B	263	74	8D	5	R556	B	223	36	5B	6
R250-E				7D	3	R460	B	275	73	8D	5	R557	B	203	44	5C	6
R250-F				7D	3	R461	B	283	69	8D	5	R558	A	217	40	5B	6
R250-G				7D	3	R462	B	280	69	9D	5	R559	A	208	40	5B	6
R250-H				7D	3	R463	B	277	73	9D	5	R560	A	217	43	5C	6
R251	A	150	41	9E	3	R469	B	280	82	9E	5	R561	B	290	34	8E	6
R252	B	58	53	8D	3	R470	B	286	87	9D	5	R564	A	271	25	9C	6
R301	A	81	30	4E	4	R471	B	287	78	9D	5	R566	B	271	20	9C	6
R302	B	36	29	4E	4	R472	B	287	81	9D	5	R567	B	262	20	10C	6
R303	B	36	26	5E	4	R473	B	289	87	9D	5	R568	B	263	9	11C	6
R304	B	36	31	5E	4	R474	B	291	83	10D	5	R570	A	250	44	7C	6
R305	A	56	29	5E	4	R475	B	285	75	9C	5	R571	B	271	27	9C	6
R306	A	56	27	5E	4	R480	B	269	70	10E	5	R572	A	258	24	10C	6
R307	B	36	23	5E	4	R481	B	258	75	10E	5	R575	A	265	24	10C	6
R308	B	43	22	5E	4	R482	B	261	81	10D	5	R576	B	258	28	10C	6
R309	A	56	24	5E	4	R485	B	297	78	10D	5	R577	B	270	40	8D	6
R320	B	29	37	7E	4	R486	B	300	76	10D	5	V110	B	173	69	4E	2
R321	B	17	31	7E	4	R490	B	260	95	11D	5	V110	B	173	69	4E	1
R322	B	29	30	7E	4	R491	B	259	104	11E	5	V120	A	117	28	3D	2
R323	B	17	42	7E	4	R500	B	238	62	3E	6	V120	A	117	28	3D	1
R330	A	47	47	9D	4	R504	B	300	52	6E	6	V205	A	85	74	5E	3
R331	A	47	44	9D	4	R505	B	300	38	7E	6	V210	B	86	77	5E	3
R332	A	47	42	9D	4	R506	B	279	36	7E	6	V220	A	48	62	7D	3
R333	B	37	37	9D	4	R515	A	298	41	7E	6	V462	B	280	76	9D	5
R334	B	37	39	9D	4	R529	B	295	36	9E	6	V463	B	277	79	9E	5
R335	B	37	42	10D	4	R530	B	297	23	10E	6	V470	B	284	84	9E	5
R336	B	37	44	10D	4	R531	B	295	11	11E	6	V471	B	278	87	9D	5
R337	B	37	47	10D	4	R532	B	283	23	10E	6	V475	B	288	70	9C	5
R338	B	37	50	10D	4	R533	B	279	10	11E	6	V476	B	288	74	9D	5
R340	B	17	39	8A	4	R534	A	295	30	9F	6	V480	B	297	81	10D	5
R400	B	189	57	2E	5	R538	A	218	33	3D	6	V540	B	207	25	2D	6
R401	A	230	75	3E	5	R540	A	185	4	2C	6	V550	A	255	24	3C	6
R402	B	220	79	3E	5	R541	B	177	11	2D	6	V551	A	250	24	3B	6
R403	B	189	51	2B	5	R542	B	204	19	2D	6						

ROHDE & SCHWARZ	-I	Datum Date	XY-Liste für XY-list for	Sach-Nummer Stock-Nr	Blatt Page
		02 02.11.93	ED RECHNER PROCESSOR	1062.6309.01 XY	5-



ROHDE & SCHWARZ

Stromläufe
Bestückungspläne
Circuit diagrams
Components plans
Schémas de circuit
Plans des composants

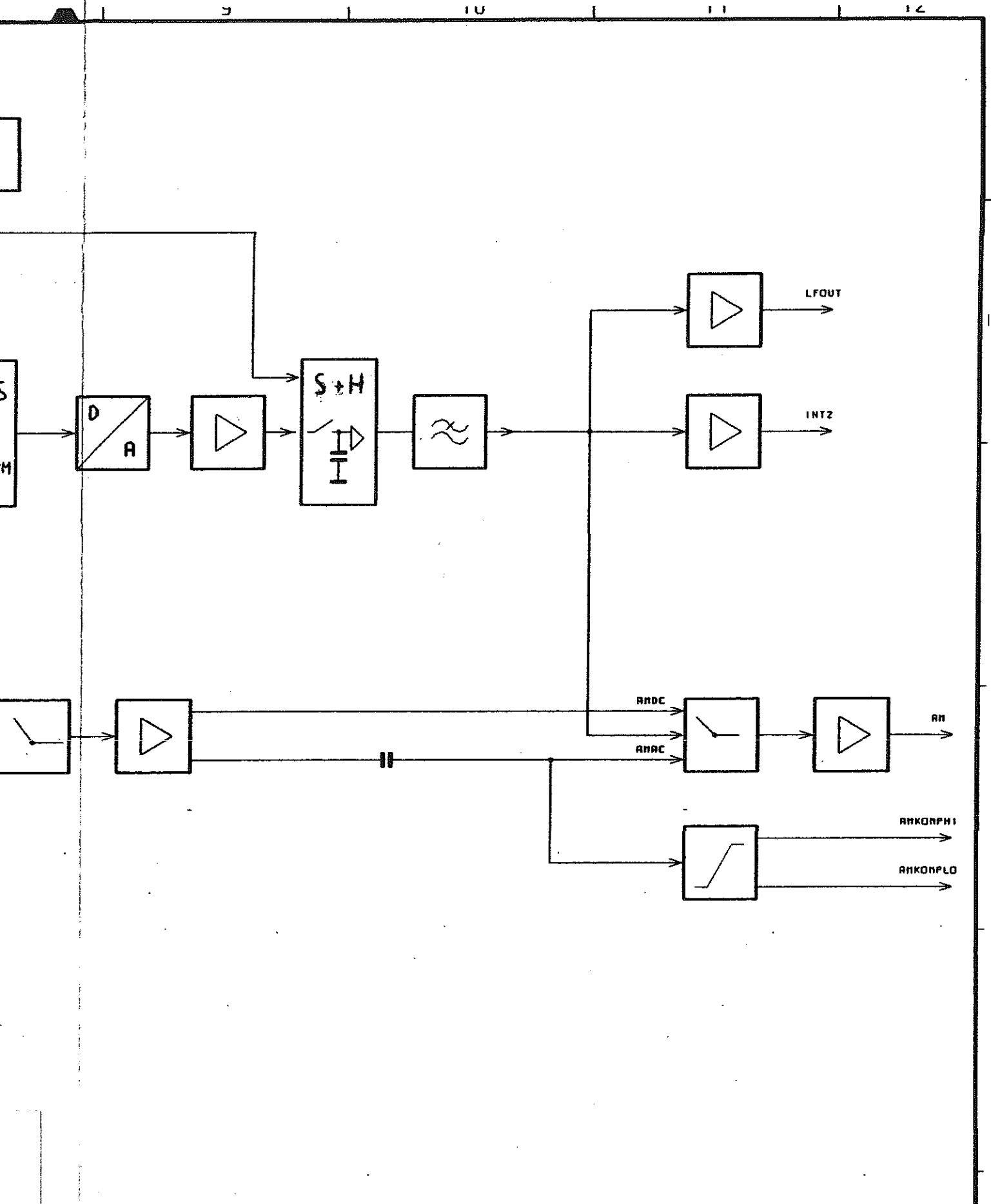

0301	03.97	EI	MANA	TRG	NADE	BENENNUNG	
			BEARB.	03.97	EI	RECHNER PROCESSOR	
			GEPR.				
			NDRN				
			PLOTT				
			 ROHDE & SCHWARZ			ZEICHN.-NR.	BLATT-NR.
						1062.6309.015	
REND. IND.	RENDERUNGS- MITTEILUNG	DATUM	NRRE	ZU GERÄT	SMY	REG. I. V.	ERSTE Z.
						1062.5502	1062.5502

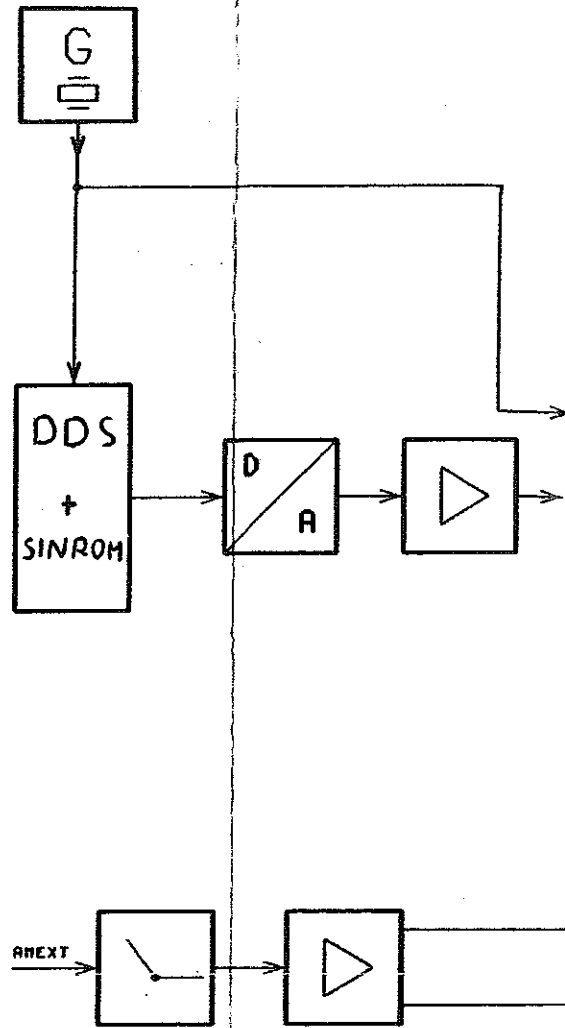
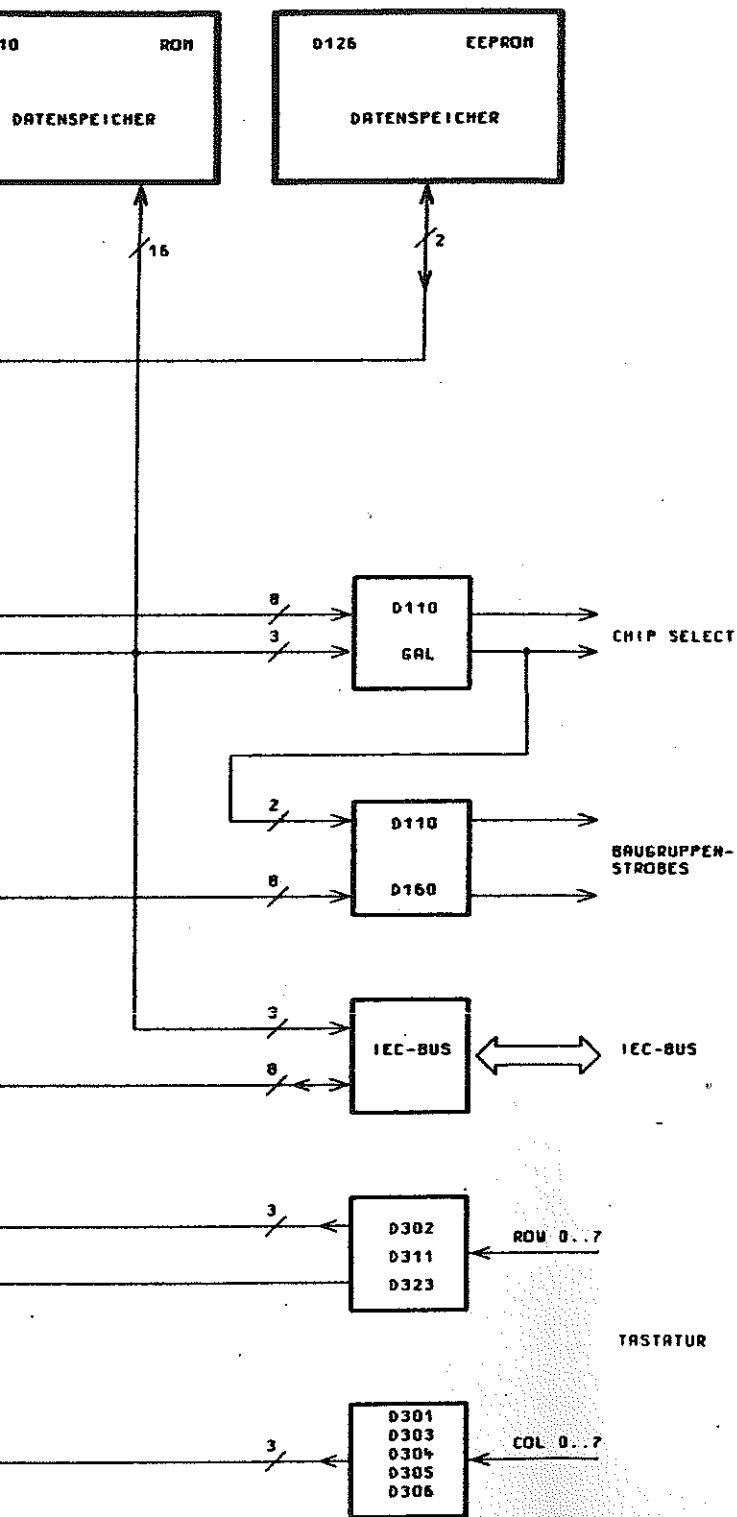

Bindende Angaben über Varianten,
Trimmwerte, Bauteilwerte und
nicht bestückte Bauteile siehe SA

For binding information on models,
trimming and components values and
nonfitted components see parts list.



03.01		03.97
REND. IND.	RENDERUNGS- MITTEILUNG	DATUM

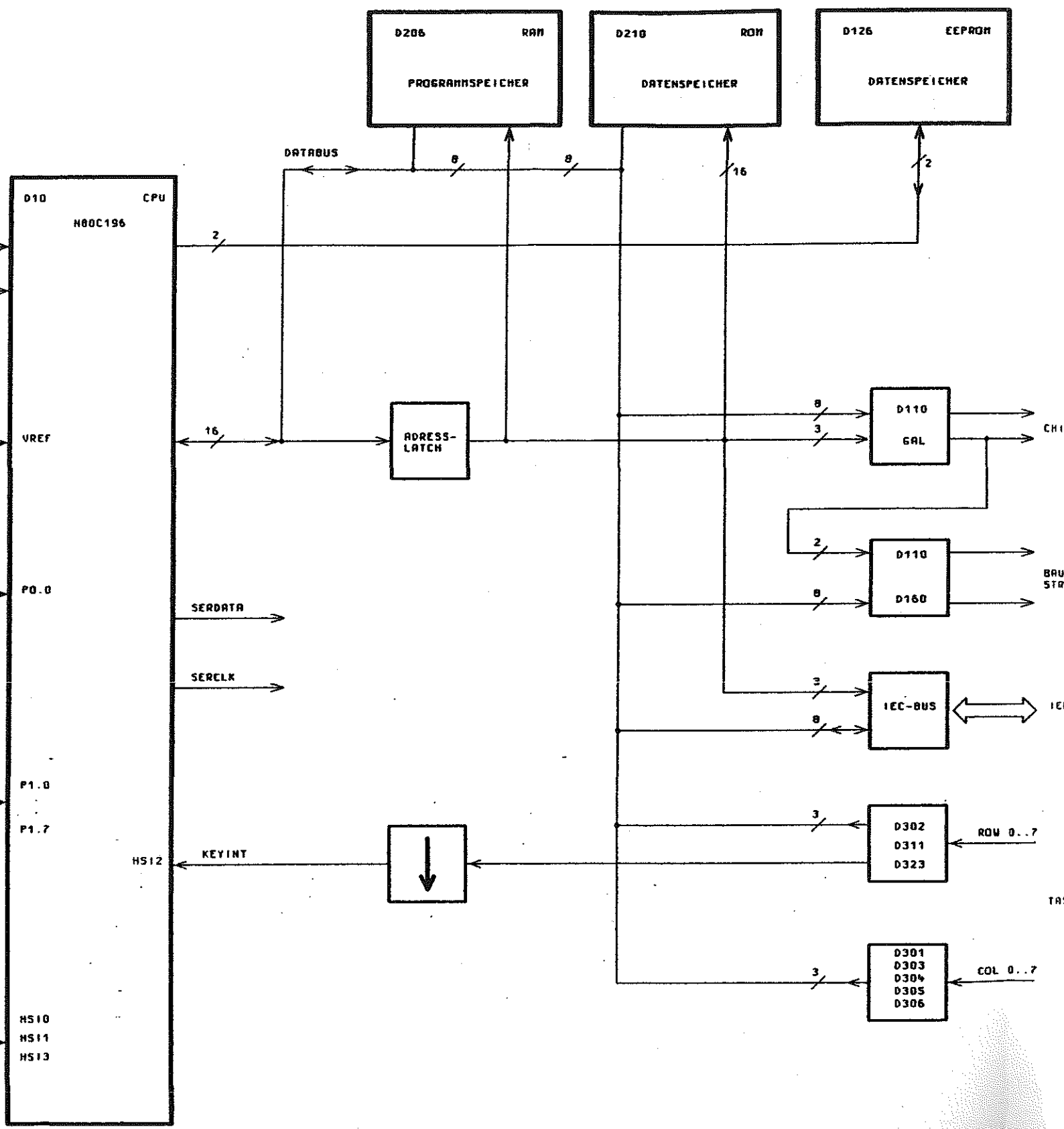

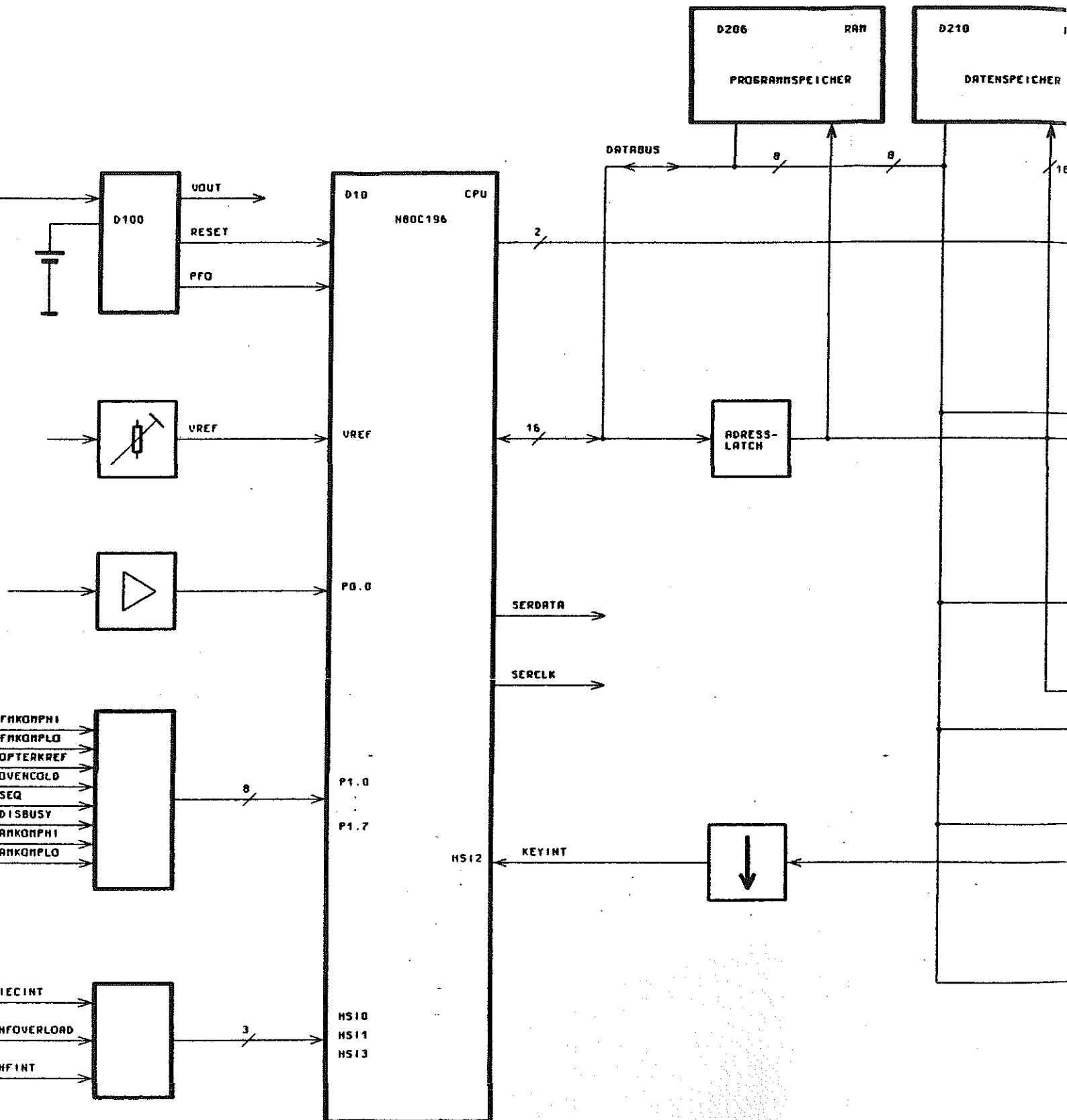

FUER DIESE UNTERLAGE
BEHALTEN WIR UNS ALLE RECHTE VOR

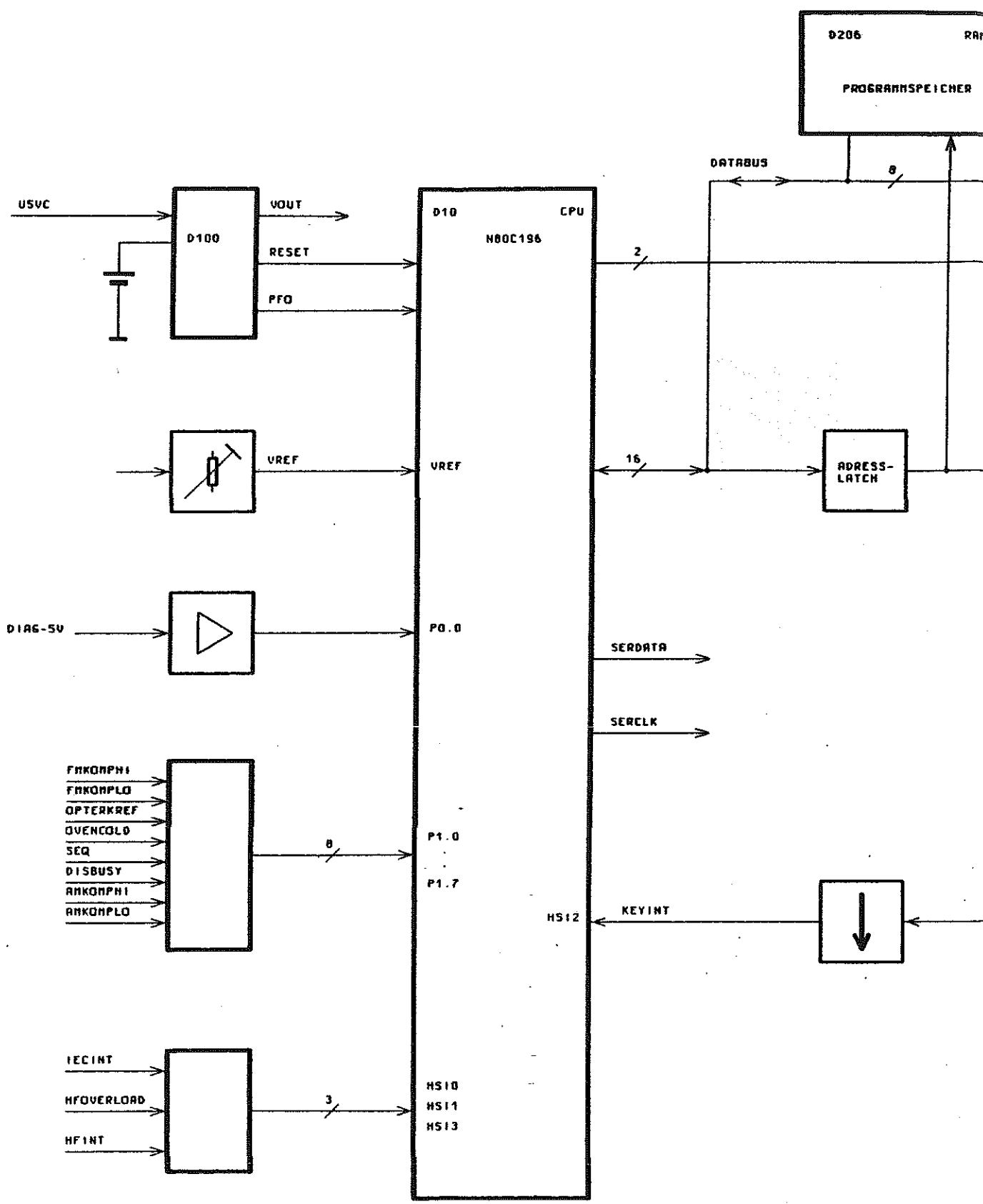

ZEICHN.-NR.

1 2 3 4

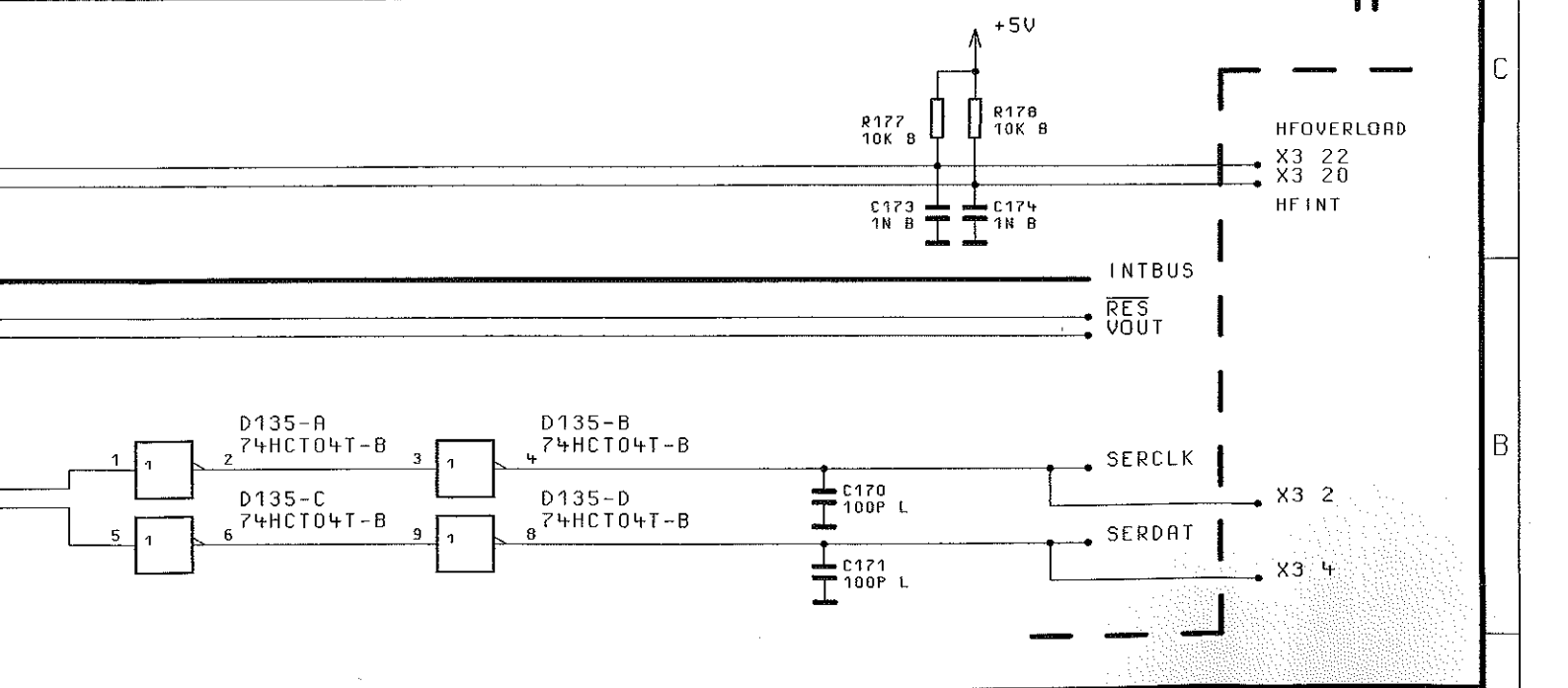
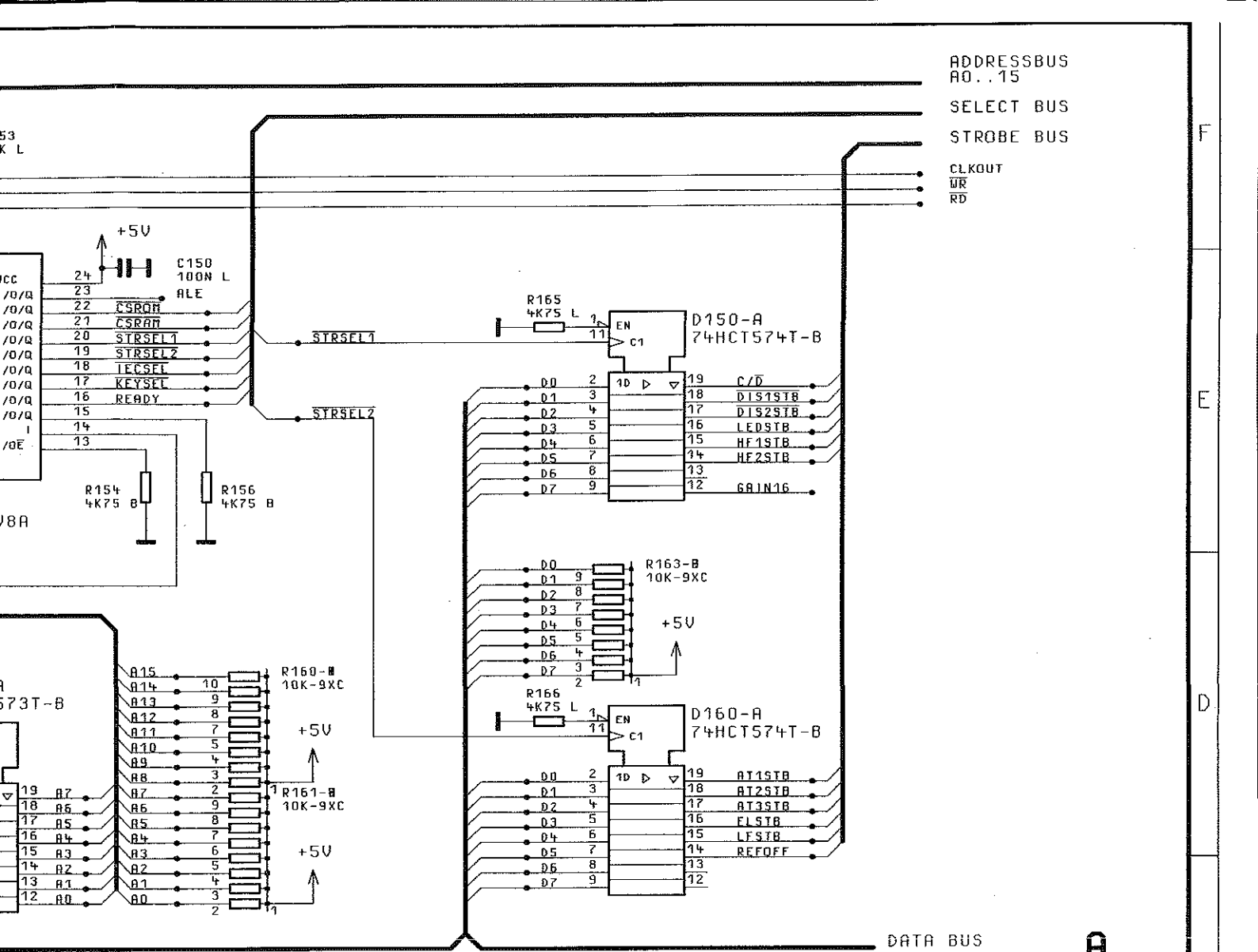

03/01	21.02.97	E1	MENP	TAG	NAME	BENENNUNG
			BEARB.		E1	RECHNER PROCESSOR
			GEPR.			
			NORM			
			PLOTT	24.02.97		
02/04	48169	12.01.95	JN			ZEICHN.-NR. 1062.6309.01S
REND. IND.	ÄNDERUNGS- MITTEILUNG	DATUM	NAME			REG.I.V. 1062.5502
						ERSTL. 1062.5502

ROHDE&SCHWARZ
 ZU GERÄT SMY

BLATT-NR.
 2+
 v. 6 BL.

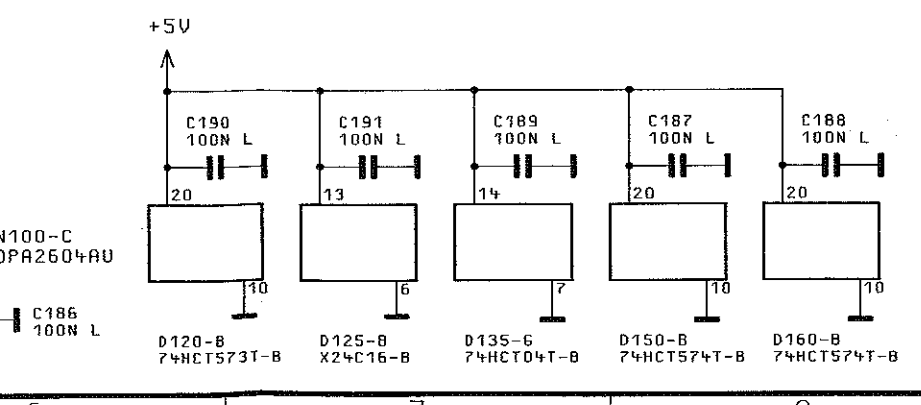
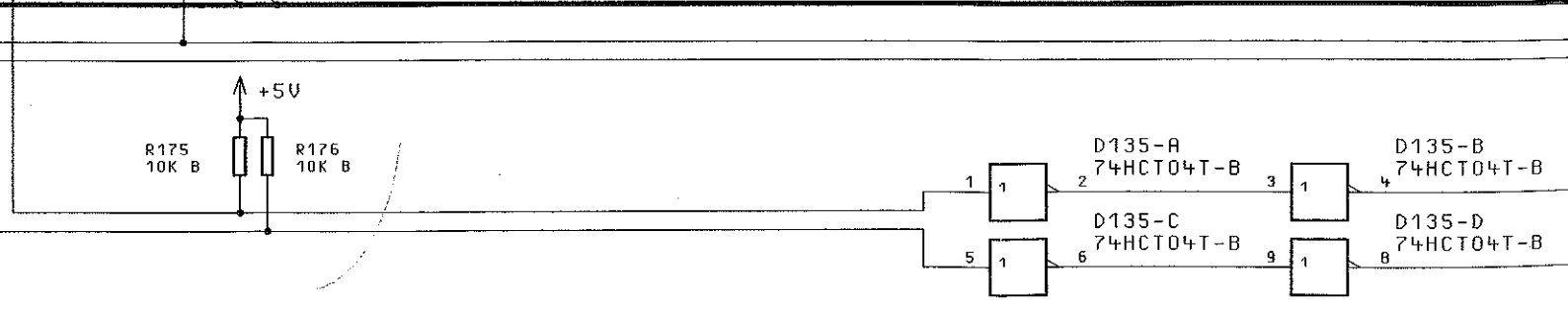
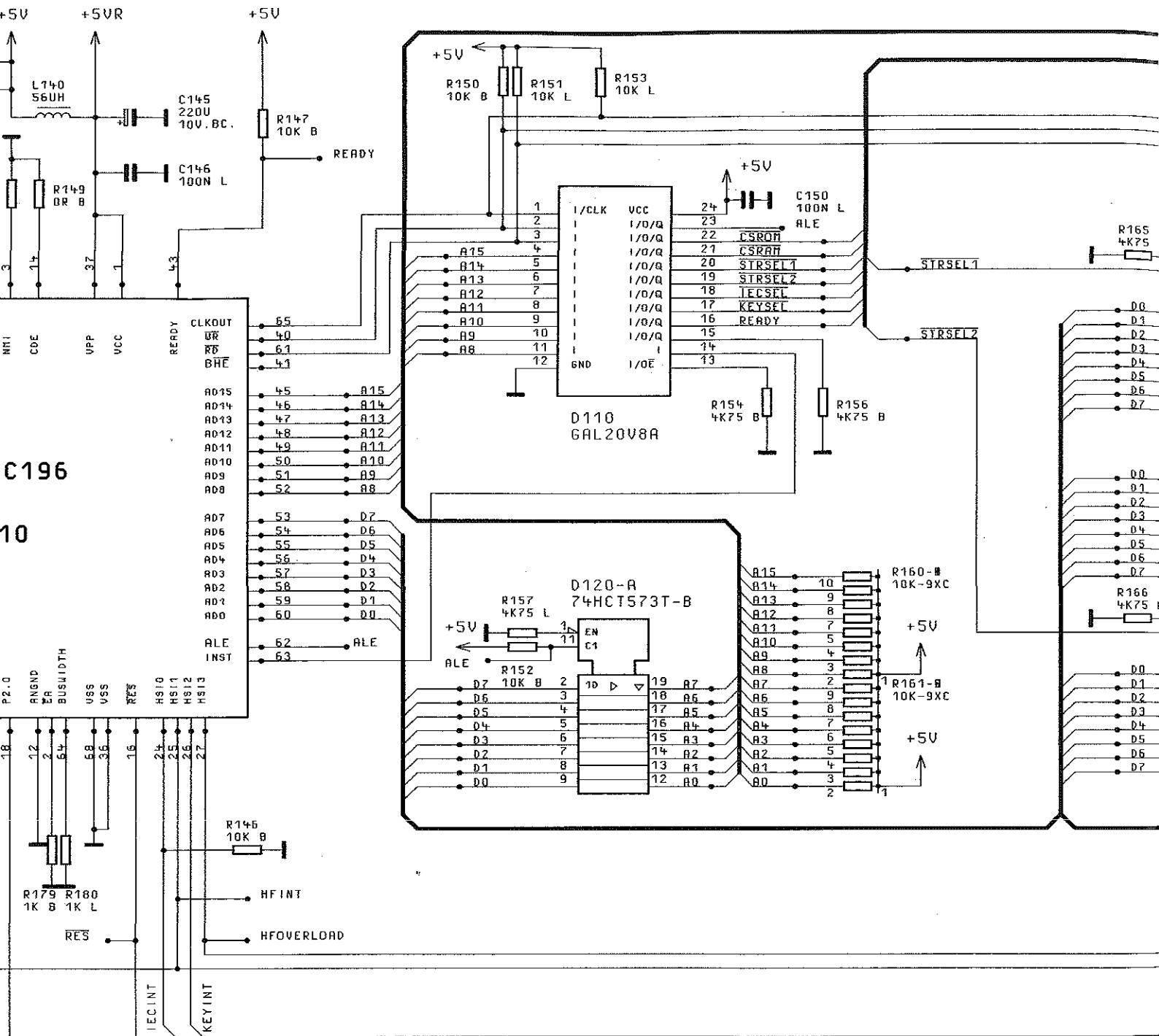

03/01		21.02.97	EI	MENP	TAG
				BEARB.	
				GEPR.	
				NORM	
				PLOTT	24.02.97
02/04	48169	12.01.95	JN	 ROHDE&SCH	
REND. IND.	BENDERUNGS-MITTEILUNG	DATUM	NAME		

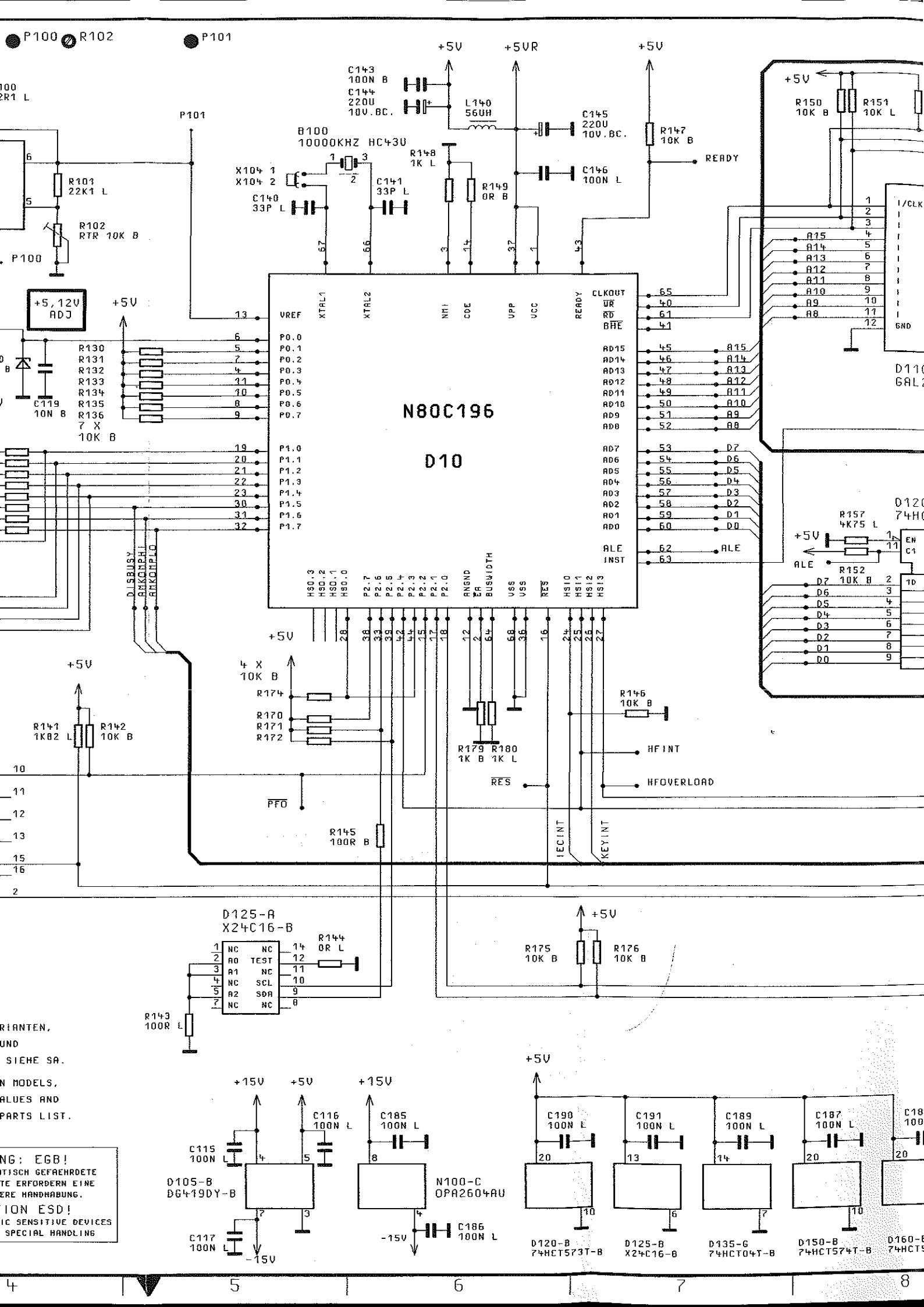

P100 R102 P101

+5V +5VR +5V

C143
100N B
C144
220U
10V. BC.

B100
10000KHZ HC43U

L140
56UH

C145
220U
10V. BC.

C141
33P L

C146
100N L

R150
10K B
R151
10K L

R101
22K1 L
R102
RTR 10K B

X104 1
X104 2

C140
33P L

+5, 12V
ADJ

R130
R131
R132
R133
R134
R135
R136
7 X
10K B

P1.0
P1.1
P1.2
P1.3
P1.4
P1.5
P1.6
P1.7

R141
1K82 L
R142
10K B

R174
R170
R171
R172

R143
100R L

D105-B
DG419DY-B

C115
100N L
C117
100N L

N80C196

D10

D125-A
X24C16-B

1 NC
2 A0
3 A1
4 NC
5 A2
7 NC

R144
OR L

R175
10K B
R176
10K B

+15V +15V +15V

C116
100N L

C185
100N L

N100-C
OPA2604AU

C186
100N L

+5V

C190
100N E

C191
100N L

C189
100N L

C187
100N L

C188
100N L

D120-B
74HCT573T-B

D125-B
X24C16-B

D135-G
74HCT04T-B

D150-B
74HCT574T-B

D160-B
74HCT574T-B

RIANTEN,
UND
SIEHE SA.
N MODELS,
VALUES AND
PARTS LIST.

NG: EGB!
TJTSCH GEFAHREHETE
TE ERFORERN EINE
ERE HANDABUNG.
ION ESD!
IC SENSITIVE DEVICES
SPECIAL HANDLING

4 5 6 7 8

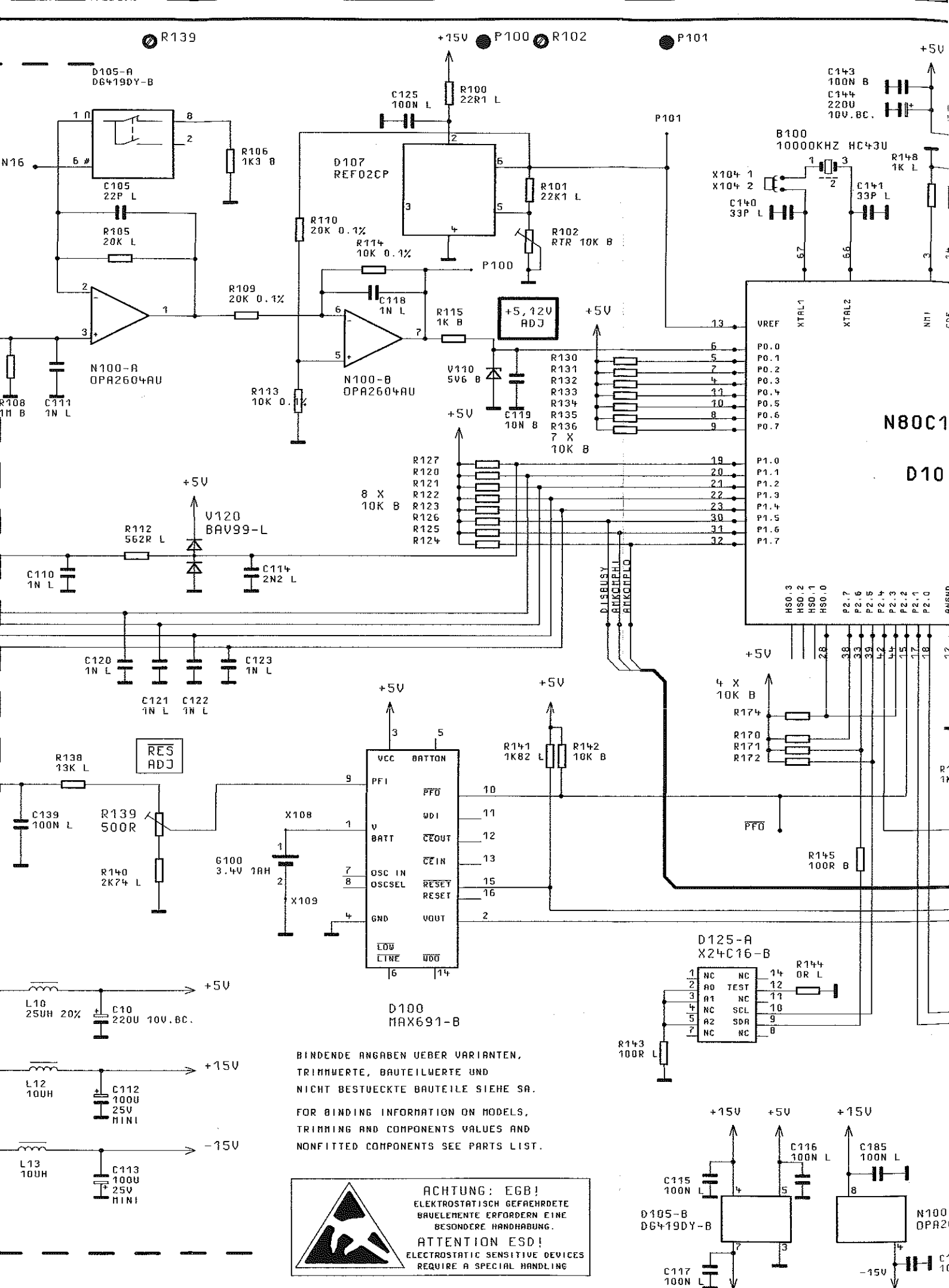

BINDENDE ANGABEN UEBER VARIANTEN,
TRIMMWERTE, BAUTEILWERTE UND
NICHT BESTUECKTE BAUTEILE SIEHE SA.

FOR BINDING INFORMATION ON MODELS,
TRIMMING AND COMPONENTS VALUES AND
NONFITTED COMPONENTS SEE PARTS LIST.



ACHTUNG: EGB!
ELEKTROSTATISCH GEFAHRDETE
BAUELEMENTE ERFORDERN EINE
BESONDERE HANDHABUNG.

ATTENTION ESD!
ELECTROSTATIC SENSITIVE DEVICES
REQUIRE A SPECIAL HANDLING

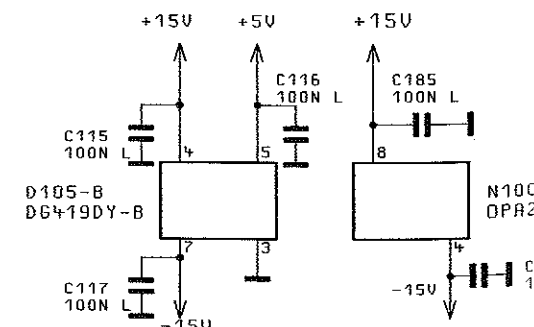

FÜR DIESE UNTERLAGE
 BEHALTEN WIR UNS ALLE RECHTE VOR

ZEICHN. - N°

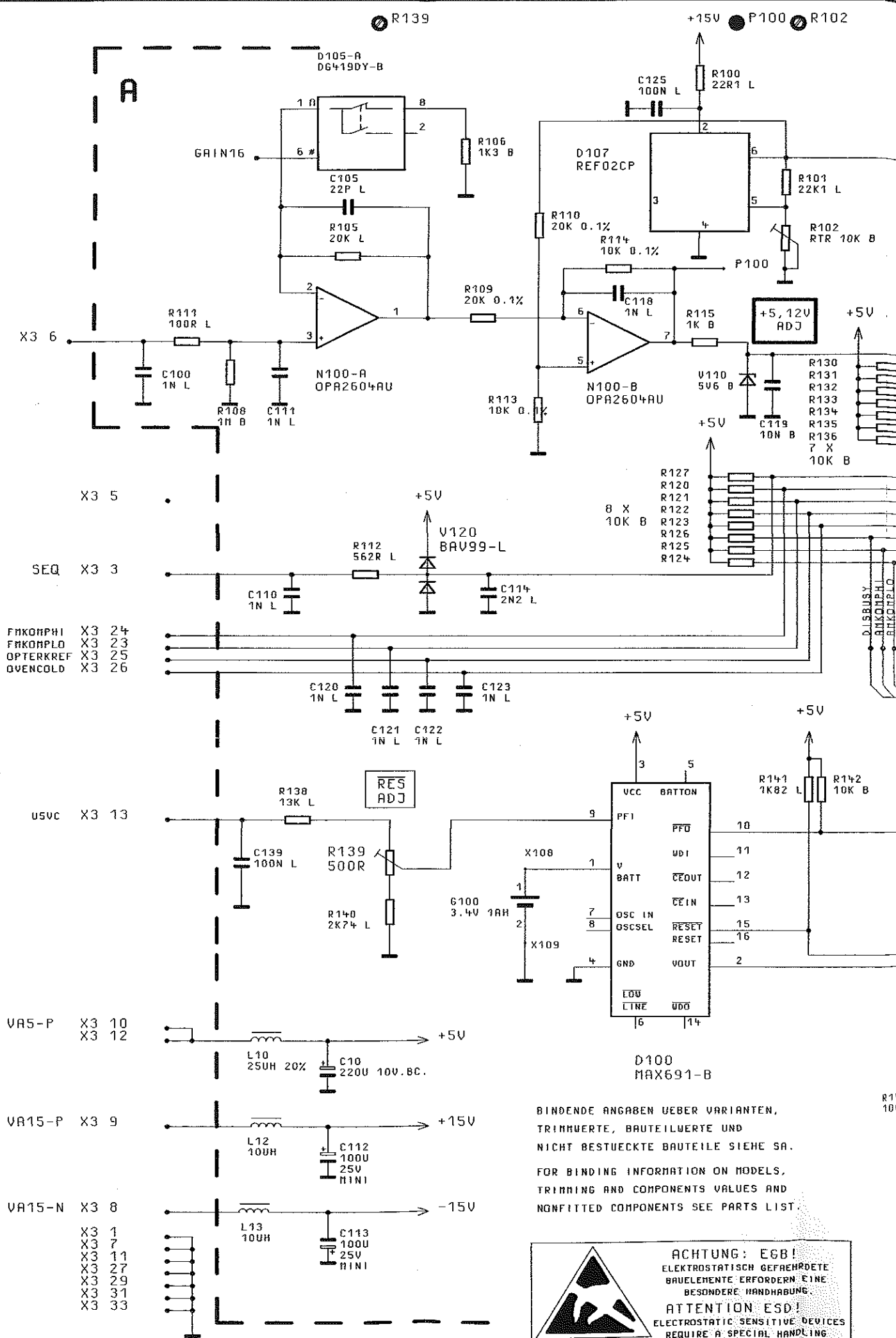

BINDENDE ANGABEN UEBER VARIANTEN,
 TRIMMWERTE, BAUTEILWERTE UND
 NICHT BESTUECKTE BAUTEILE SIEHE SA.
 FOR BINDING INFORMATION ON MODELS,
 TRIMMING AND COMPONENTS VALUES AND
 NONFITTED COMPONENTS SEE PARTS LIST.



ACHTUNG: EGB!
 ELEKTROSTATISCH GEFÄHRDETE
 BAUELEMENTE ERFORDERN EINE
 BESONDERE HANDHABUNG.
ATTENTION ESD!
 ELECTROSTATIC SENSITIVE DEVICES
 REQUIRE A SPECIAL HANDLING

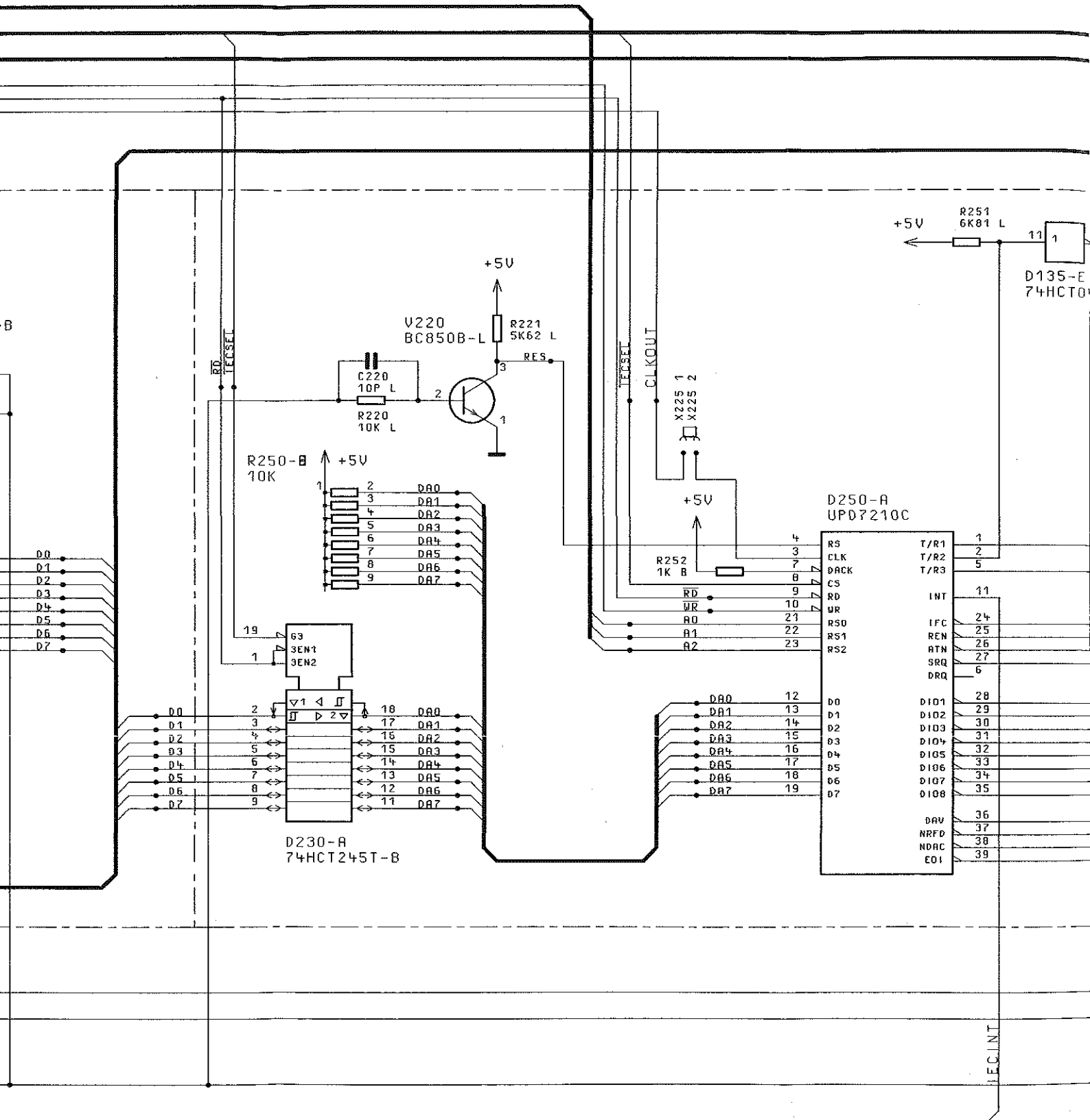

BINDENDE ANGABEN UEBER VARIANTEN,
TRIMMWERTE, BAUTEILWERTE UND
NICHT BESTUECKTE BAUTEILE SIEHE SA.

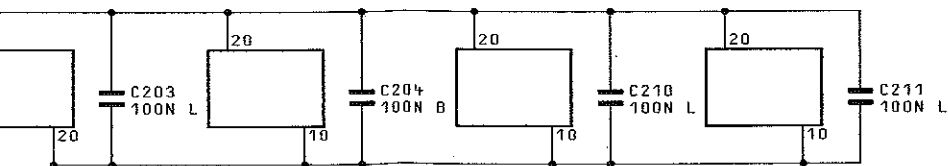

D255-B SN75160AN D260-B SN75161AN D230-B 74HCT245T-B

03/01		21.02.97	EI	ME
				BER
				GEPI
				NORI
				PLO
				PA
02/04	48169	12.01.95	JN	R
REND. IND.	RENDERUNGS- MITTEILUNG	DATUM	NAME	ZB 6

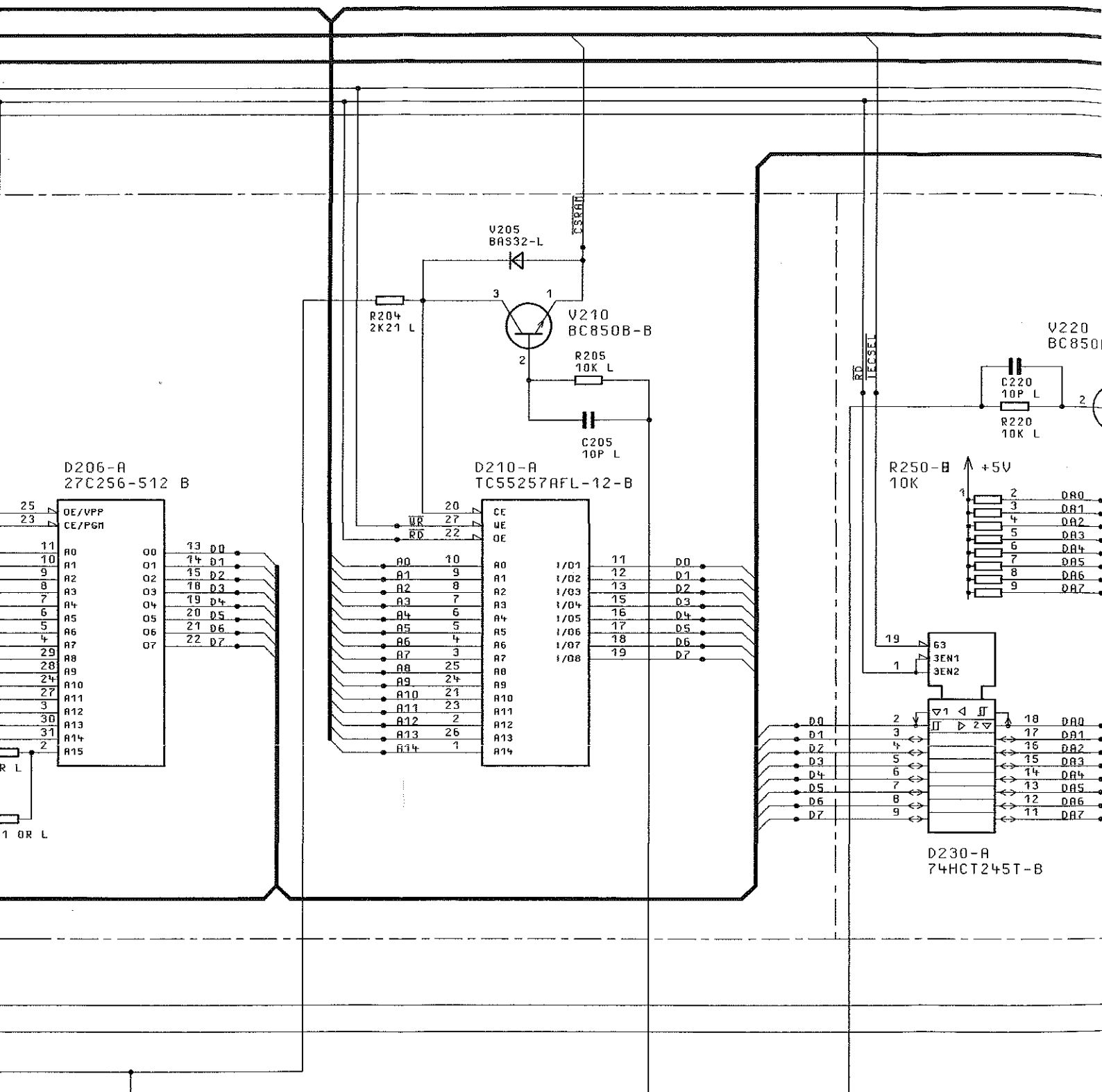

D210-B
TC55257AFL-12-B

D250-B
UPD7210C

D255-B
SN75160AN

D260-B
SN75161AN

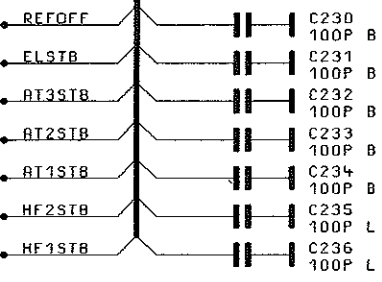

ACHTUNG: EGB!
 ELEKTROSTATISCH GEFÄHRDETE
 BAUELEMENTE ERFORDERN EINE
 BESONDERE HANDHABUNG.
ATTENTION ESD!
 ELECTROSTATIC SENSITIVE DEVICES
 REQUIRE A SPECIAL HANDLING

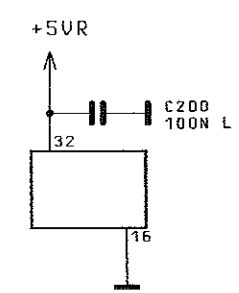
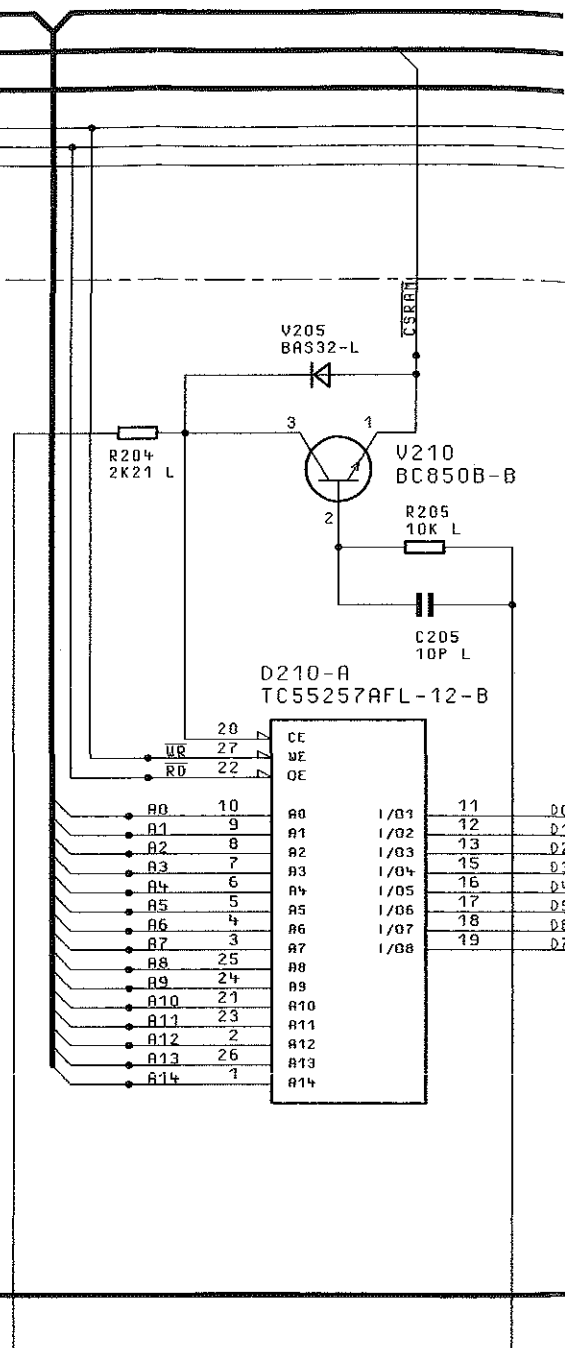
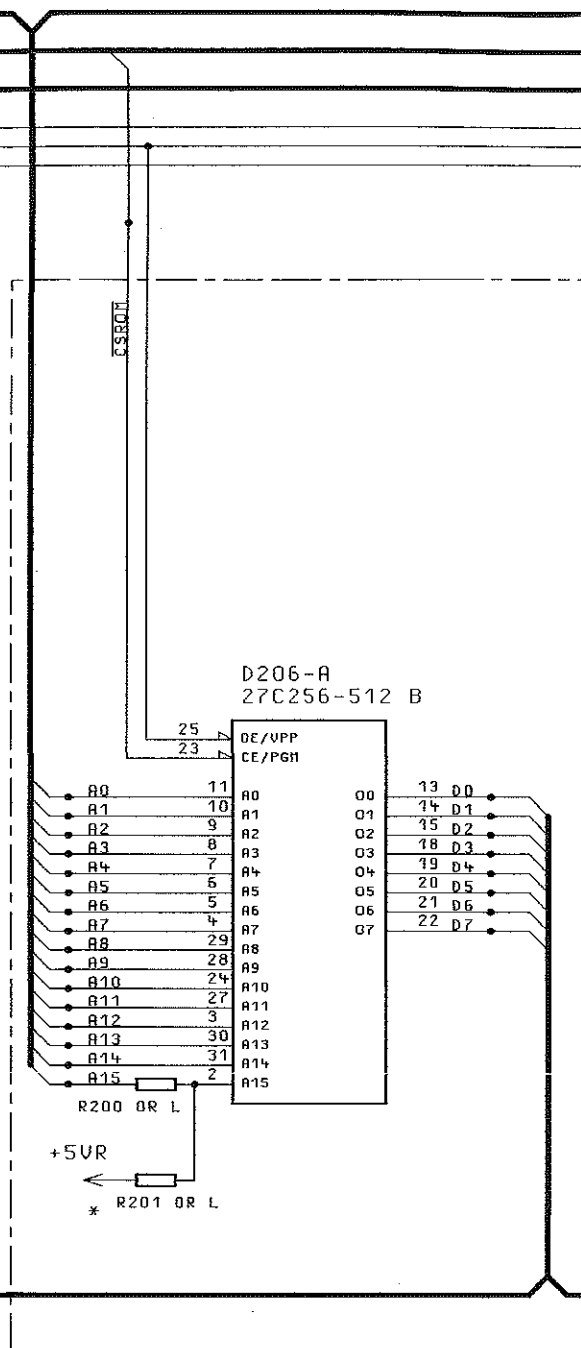

D206-B
 27C256-512 B

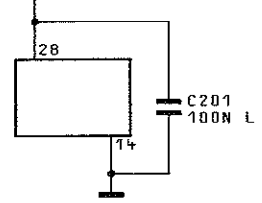

D210-B
 TC55257AFL-12-B

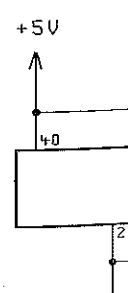

D250-B
 UPD72100

ADDRESS BUS
SELECT BUS
STROBE BUS

WR
RD
CLKOUT

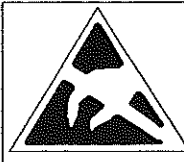
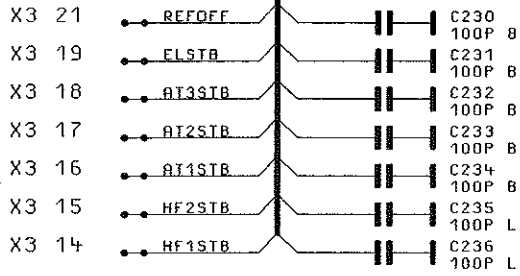

ACHTUNG: EGB!
ELEKTROSTATISCH GEFÄHRDETE
BAUELEMENTE ERFORDERN EINE
BESONDERE HANDHABUNG.
ATTENTION ESD!
ELECTROSTATIC SENSITIVE DEVICES
REQUIRE A SPECIAL HANDLING

D206-A
27C256-512 B

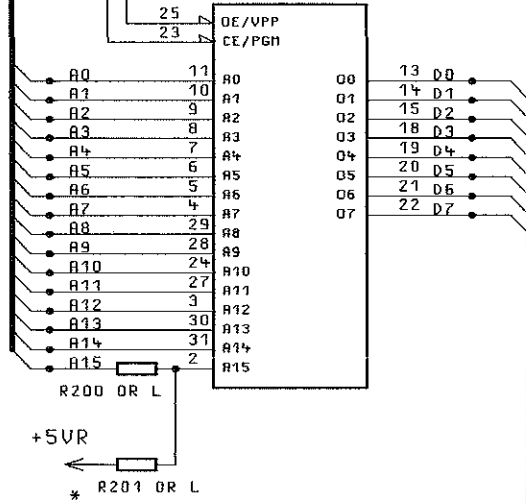

R204
2K21 L

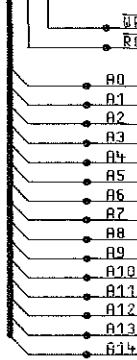

DATA BUS

SERCLK
SERDAT

VOUT
RES

INTBUS

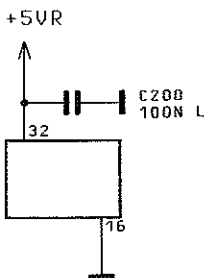

D206-B
27C256-512 B

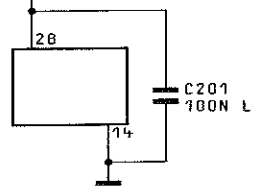

D210-B
TC55257AFL-12-B

FÜR DIESE UNTERLAGE
BEHALTEN WIR UNS ALLE RECHTE VOR

ZEICHN.-N.
100

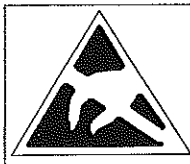

ACHTUNG: EGB!
 ELEKTROSTATISCH GEFÄHRDETE
 BAUELEMENTE ERFORDERN EINE
 BESONDERE HANDHABUNG.
ATTENTION ESD!
 ELECTROSTATIC SENSITIVE DEVICES
 REQUIRE A SPECIAL HANDLING

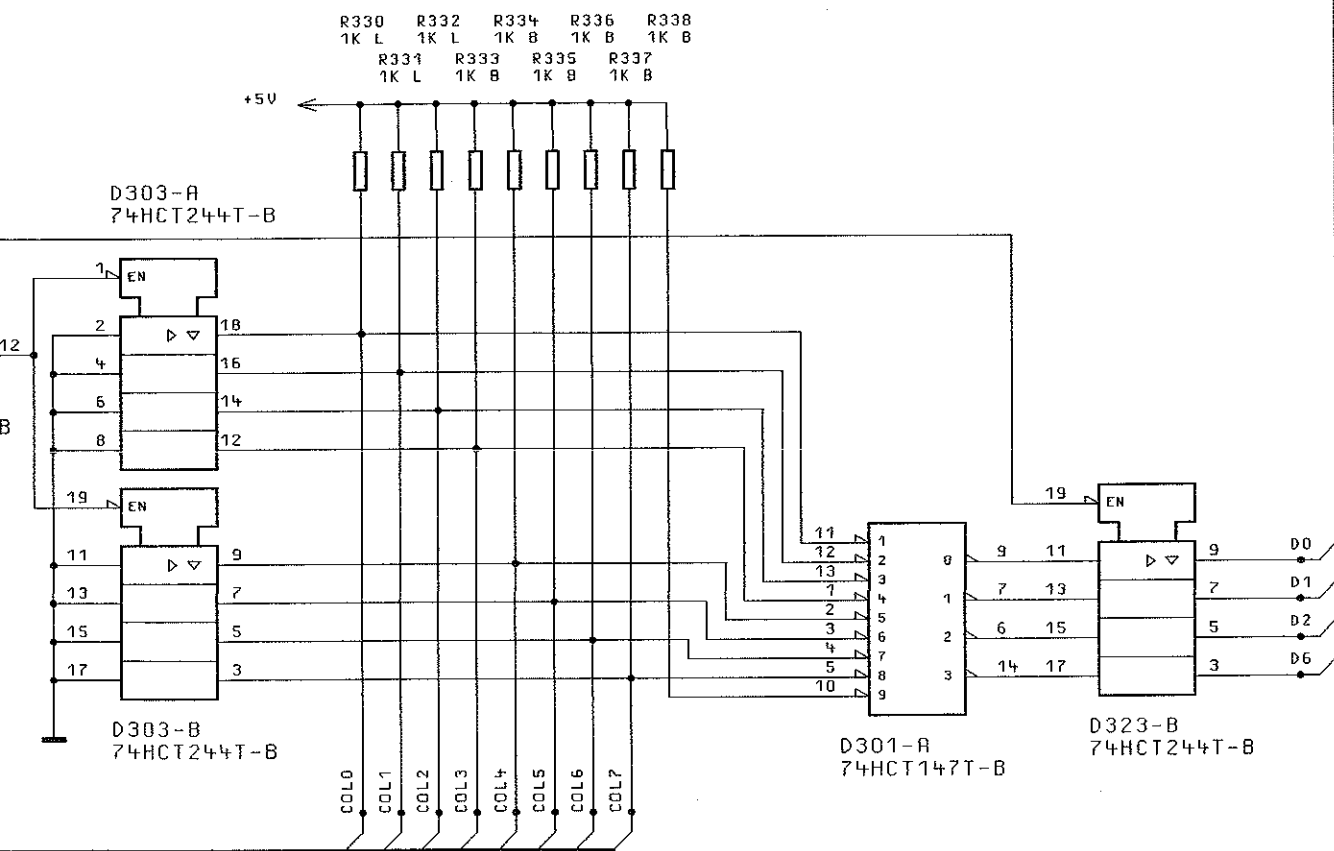

SERCLK
SERDAT

INTBUS

BINDENDE ANGABEN UEBER VARIANTEN,
 TRIMMWERTE, BAUTEILWERTE UND
 NICHT BESTUECKTE BAUTEILE SIEHE SA.

FOR BINDING INFORMATION ON MODELS,
 TRIMMING AND COMPONENTS VALUES AND
 NONFITTED COMPONENTS SEE PARTS LIST.

03/01		21.02.97	E I	MENP	TAG	NAME	BENENNUNG		
				BEARB.		E I	RECHNER PROCESSOR		
				GEPR.					
				NORM					
				PLOTT	21.02.97				
02/04	48169	12.01.95	JN	ROHDE & SCHWARZ			ZEICHN.-NR.	1062.6309.01S	BLATT-NR. 4+
AEND. IND.	AENDERUNGS-MITTEILUNG	DATUM	NAME				ZU GERÄT	SMY	REG. I. V.

9

10

11

12

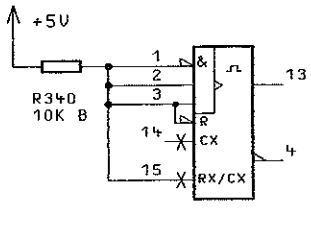
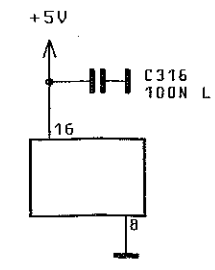
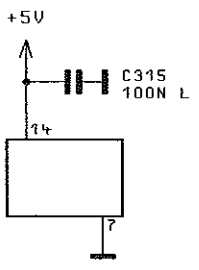
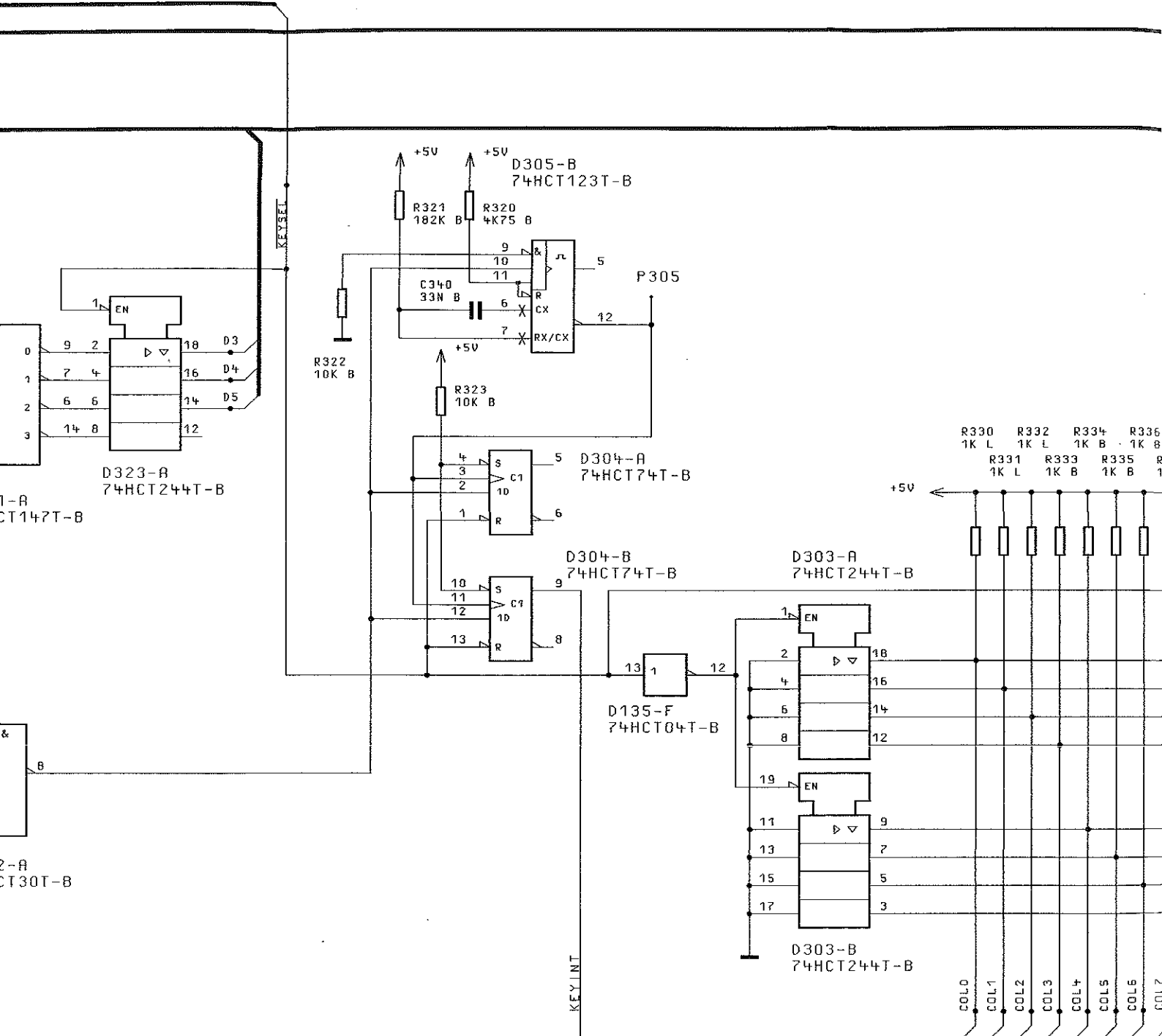

BINDENDE ANGABEN UEBER VARIANTEN, TRIMMWERTE, BAUTEILWERTE UND NICHT BESTUECKTE BAUTEILE SIEHE SA.

03/01		21.02.97	EI	MENP
				BEARB.
				GEPR.
				NORM
				PLOTT
D2/04	48169	12.01.95	JN	 ROH ZU GERÄT
REND. IND.	ÄNDERUNGS-MITTEILUNG	DATUM	NAMEN	

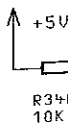
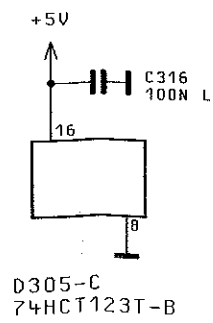
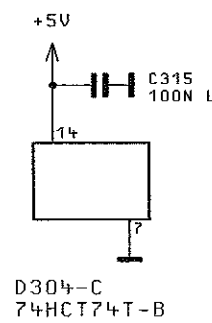
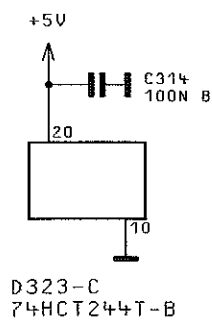
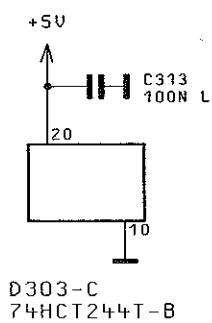
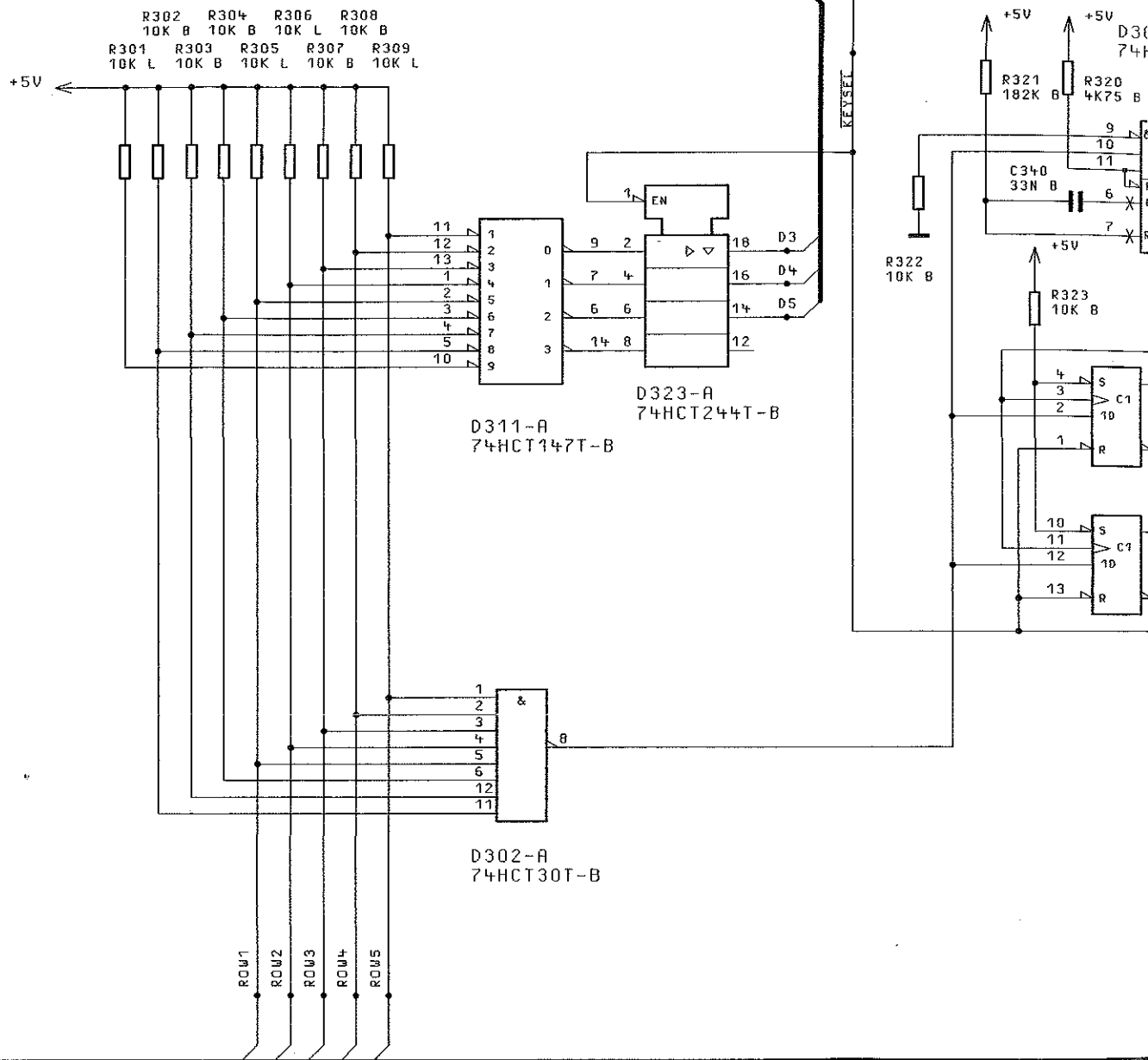

A

LAY

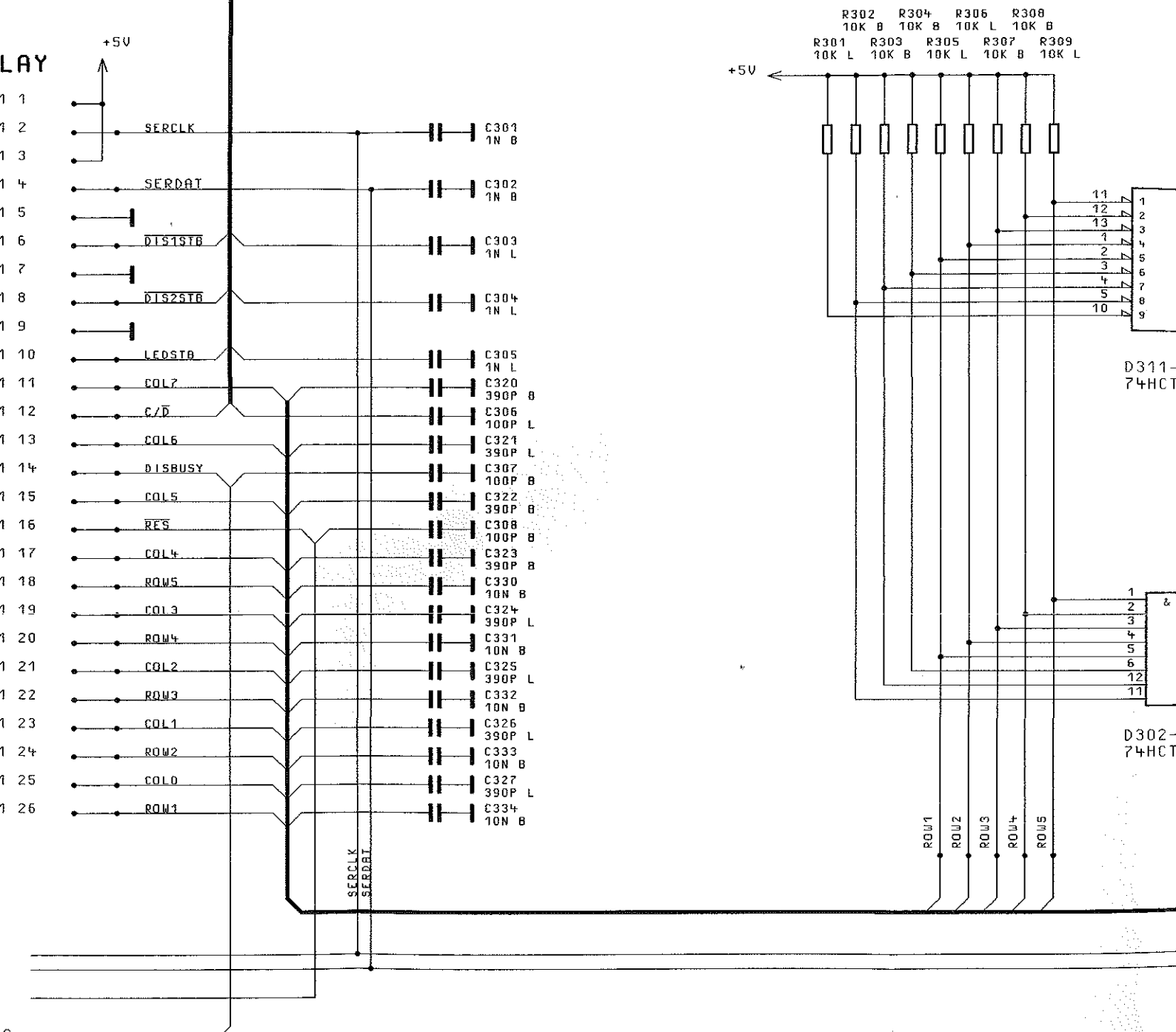

S

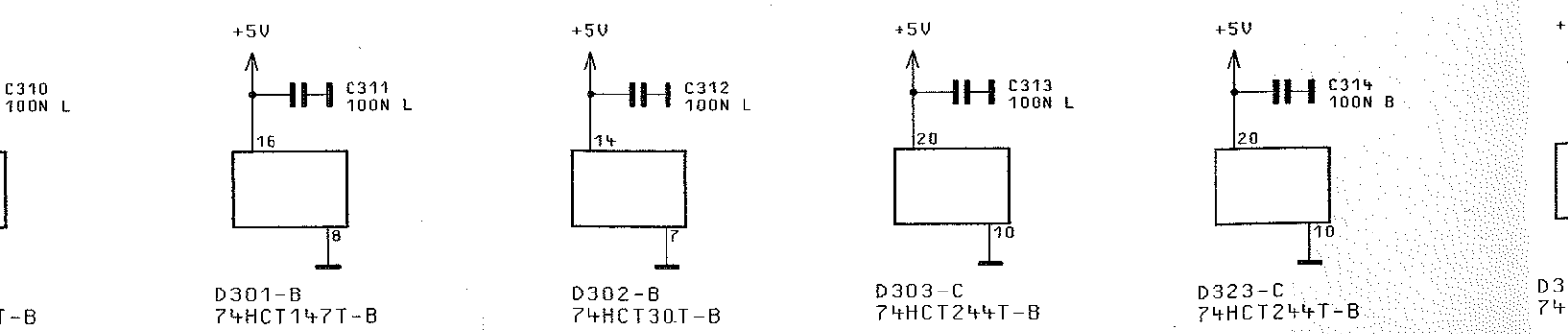

2

3

4

5

D3
74

A

SELECTBUS
STROBEBUS

DATABUS

TO
DISPLAY

- X1 1
- X1 2
- X1 3
- X1 4
- X1 5
- X1 6
- X1 7
- X1 8
- X1 9
- X1 10
- X1 11
- X1 12
- X1 13
- X1 14
- X1 15
- X1 16
- X1 17
- X1 18
- X1 19
- X1 20
- X1 21
- X1 22
- X1 23
- X1 24
- X1 25
- X1 26

+5V

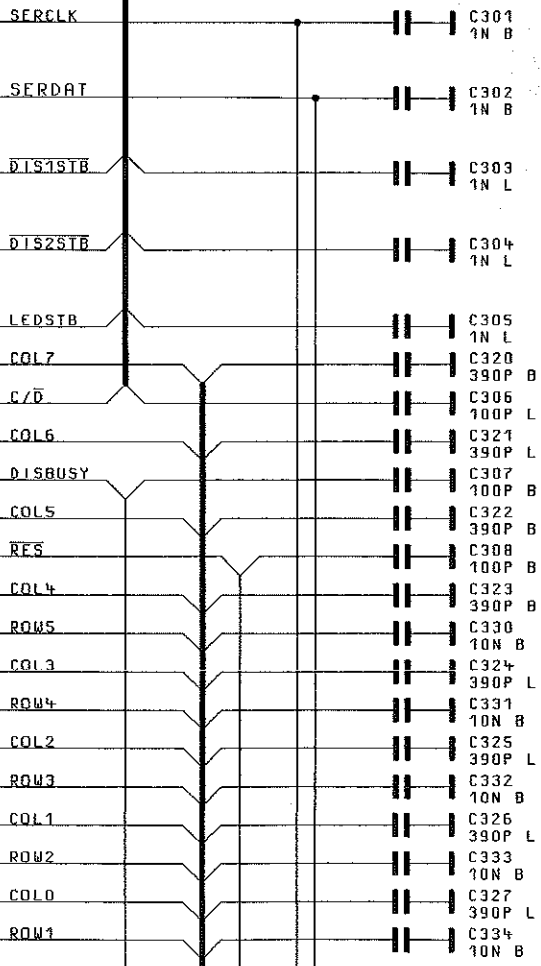

R302 R3
10K B 10
R301 R303
10K L 10K B

+5V

SERCLK
SERDAT

RES

INTBUS

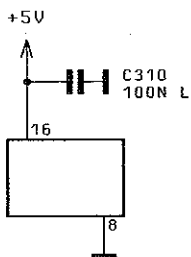

D311-B
74HCT147T-B

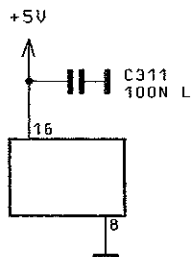

D301-B
74HCT147T-B

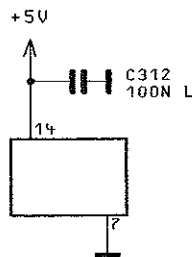

D302-B
74HCT30T-B

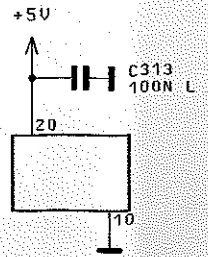

D303-C
74HCT244T-B

1

2

3

4

FUER DIESE UNTERLAGE
BEHALTEN WIR UNS ALLE RECHTE VOR

ZEICHN.-NR.



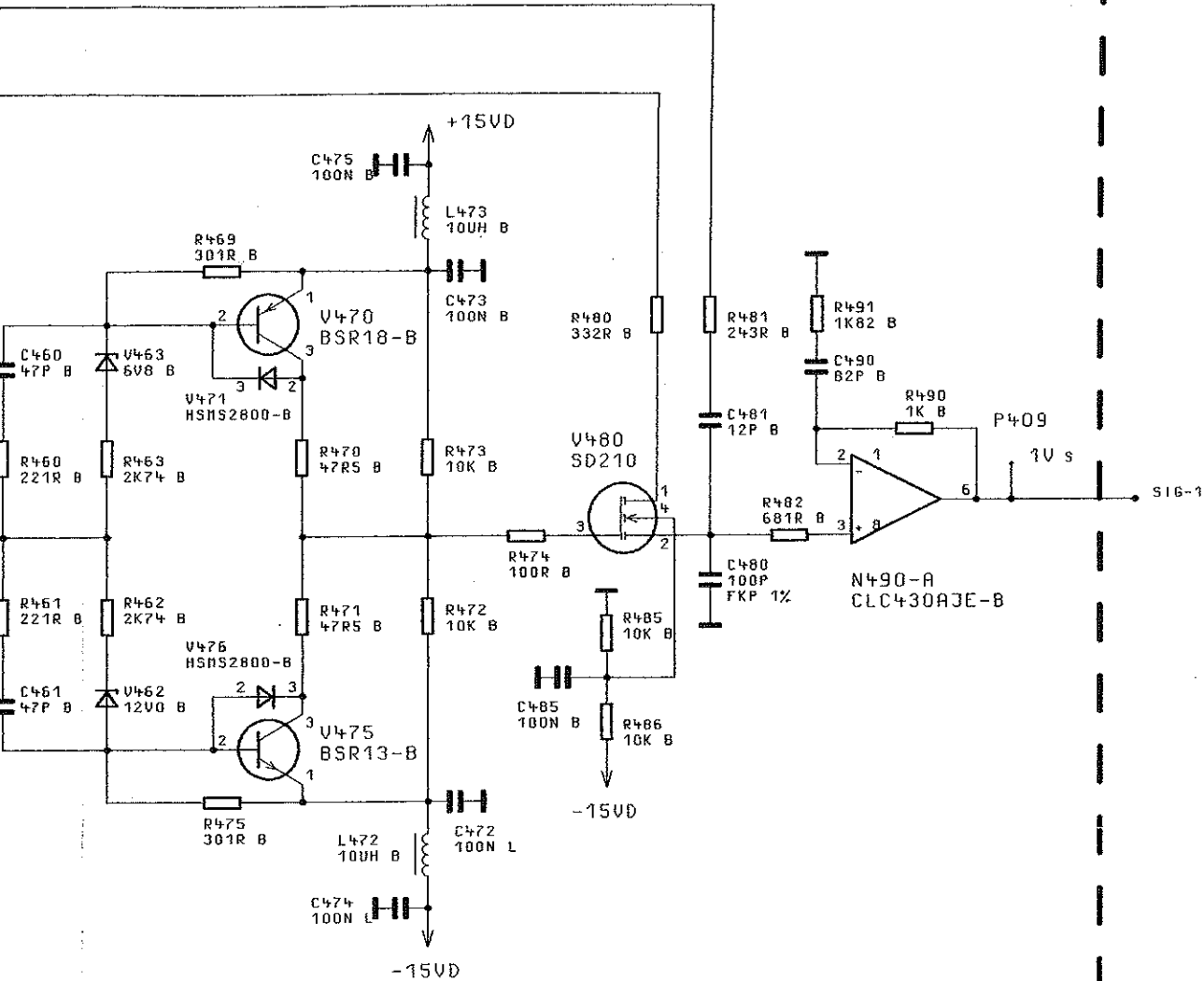



ACHTUNG: EGB!
 ELEKTROSTATISCH GEFÄHRDETE
 BAUELEMENTE ERFORDERN EINE
 BESONDERE HANDHABUNG.
ATTENTION ESD!
 ELECTROSTATIC SENSITIVE DEVICES
 REQUIRE A SPECIAL HANDLING

BINDENDE ANGABEN UEBER VARIANTEN,
 TRIMMWERTE, BAUTEILWERTE UND
 NICHT BESTUECKTE BAUTEILE SIEHE SA.

FOR BINDING INFORMATION ON MODELS,
 TRIMMING AND COMPONENTS VALUES AND
 NONFITTED COMPONENTS SEE PARTS LIST.

03/01		21.02.97	EI	MENP	TAG	NAME	BEKENNUNG		
				BEARB.		EI	RECHNER PROCESSOR		
				GEPR.					
				NORM					
				PLOTT	24.02.97				
02/04	48169	12.01.95	JN	 ROHDE & SCHWARZ	ZEICHN.-NR.		BLATT-NR.		
ÄND. IND.	ÄNDERUNGS- MITTEILUNG	DATUM	NAME		1062.6309.01S		5+ v. 6 BL.		
				ZU GERÄT	SMY	REG.-I.V.	1062.5502	ERSTE Z.	1062.5502

R450 P405
P406

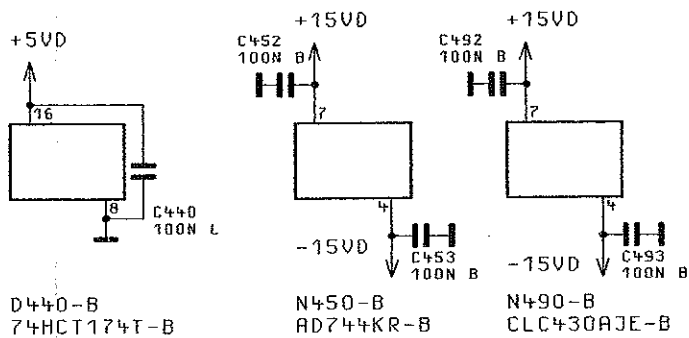
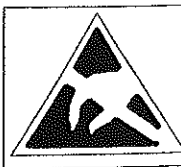
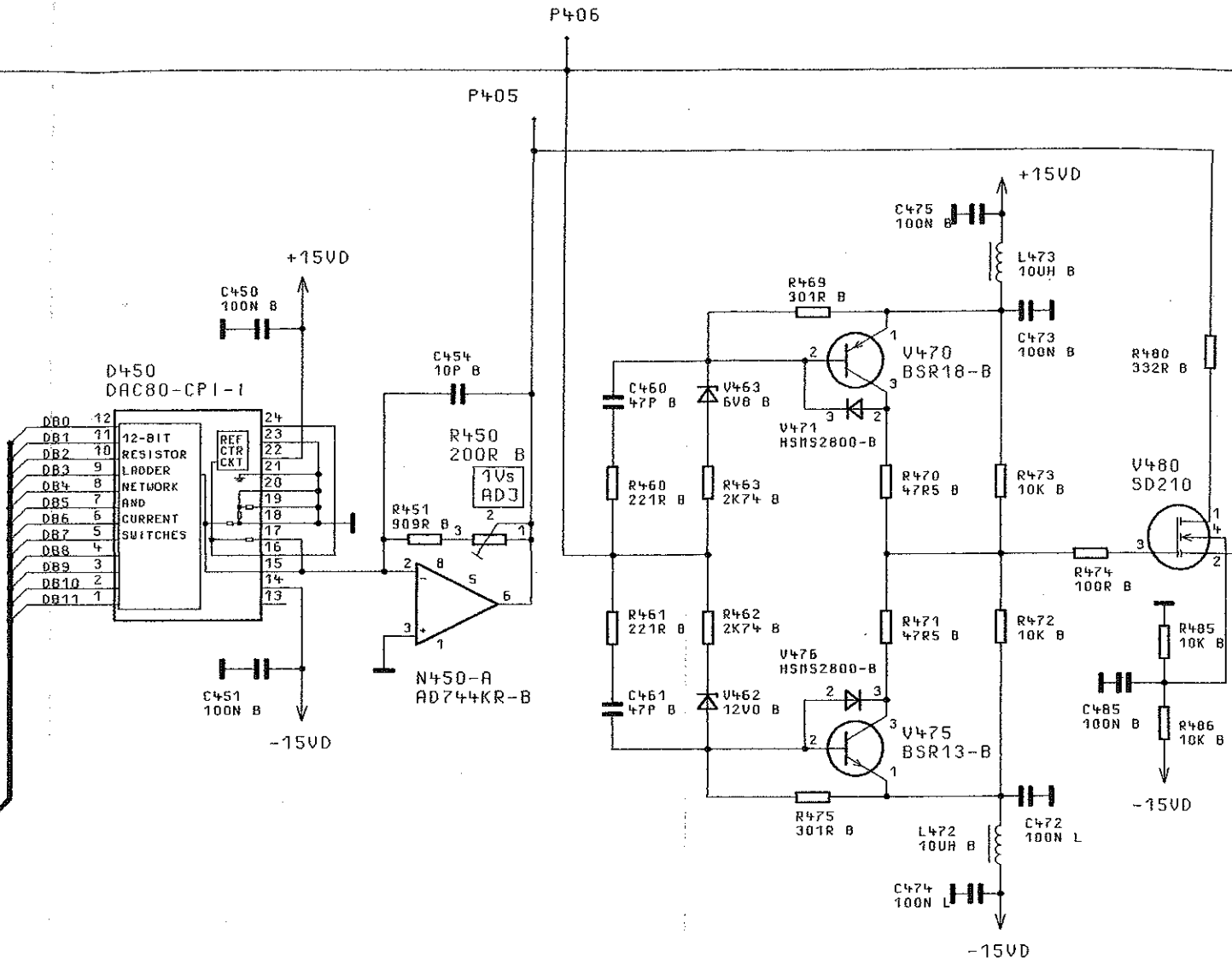

BINDENDE ANGABEN UEBER VARIANTEN,
TRIMMWERTE, BAUTEILWERTE UND
NICHT BESTUECKTE BAUTEILE SIEHE SA.

FOR BINDING INFO
TRIMMING AND COM
NONFITTED COMPON

03/01		21.02.97	EI	MENP	TAG	NAME
				BEARB.		EI
				GEPR.		
				NORM		
				PLOTT	24.02.97	
02/04	48169	12.01.95	JN			
REND IND:	ÄNDERUNGS- MITTEILUNG	DATUM	NAMEN	ROHDE & SCHWARZ ZU GERÄT SMY		

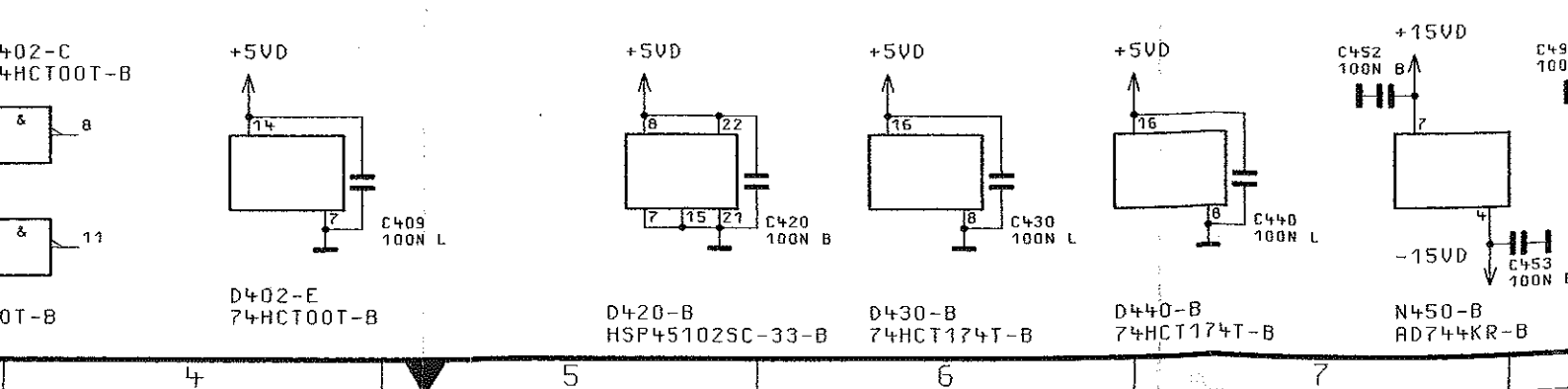
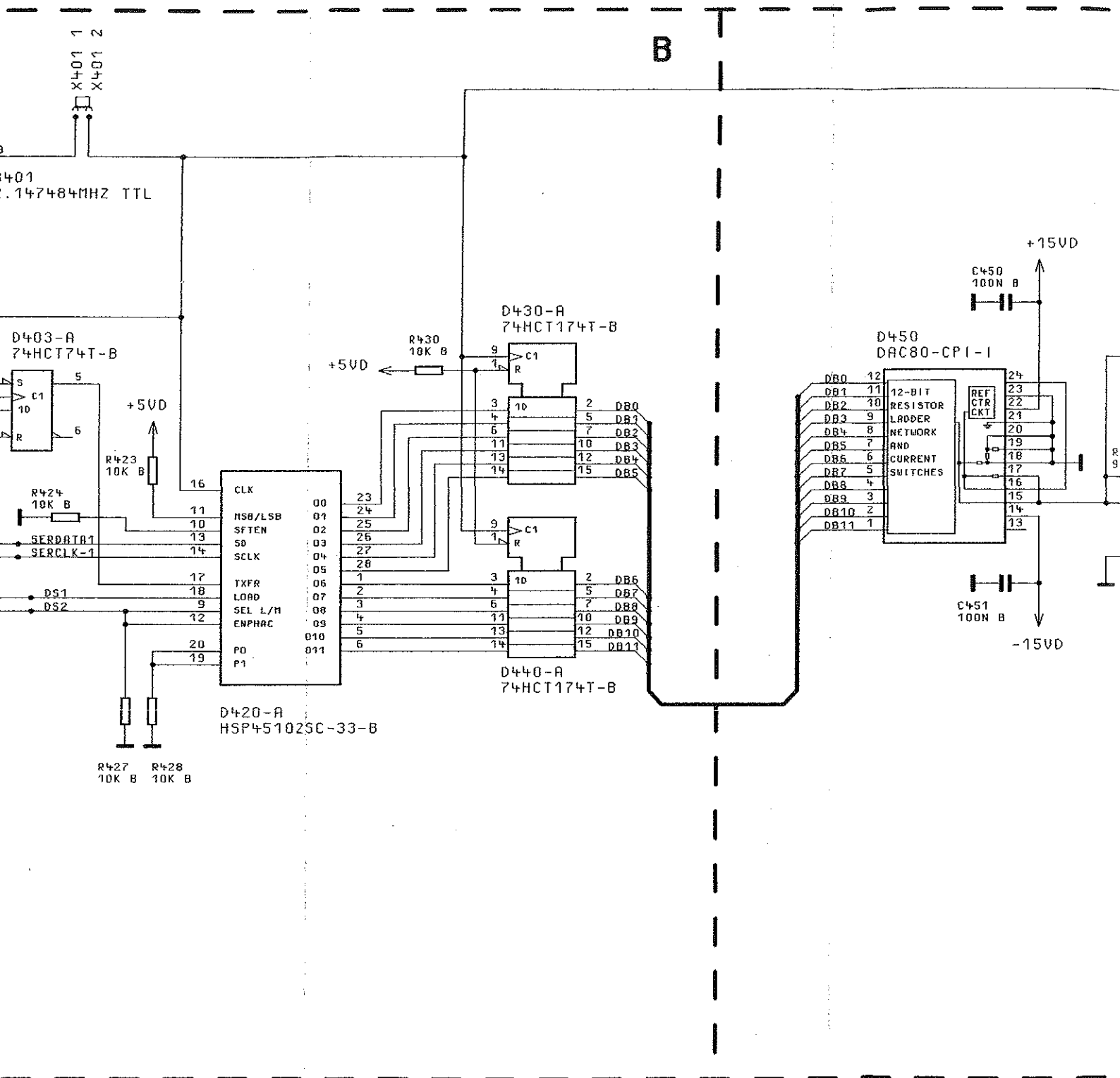

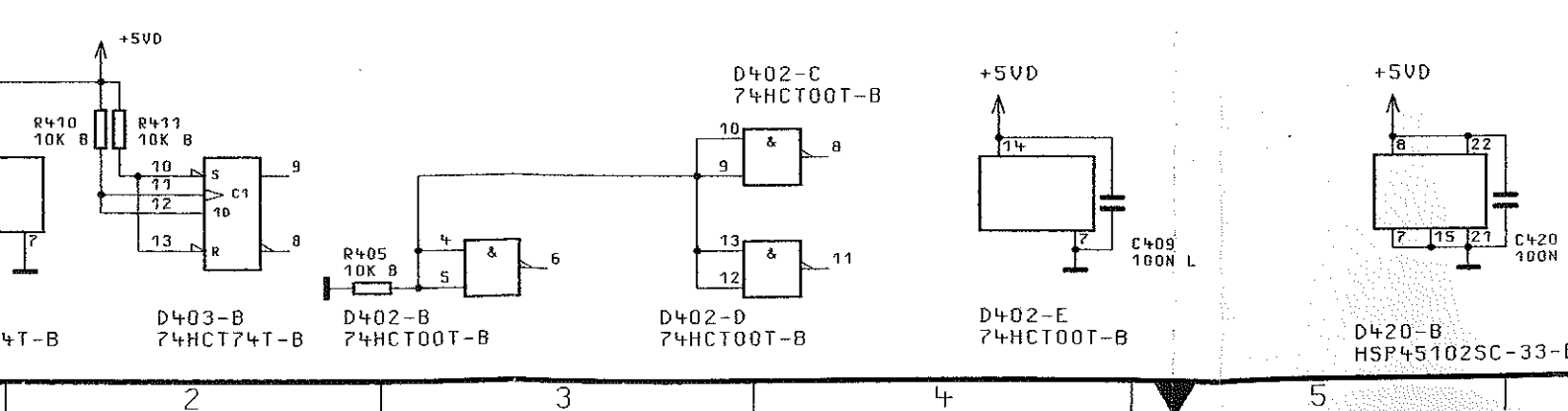
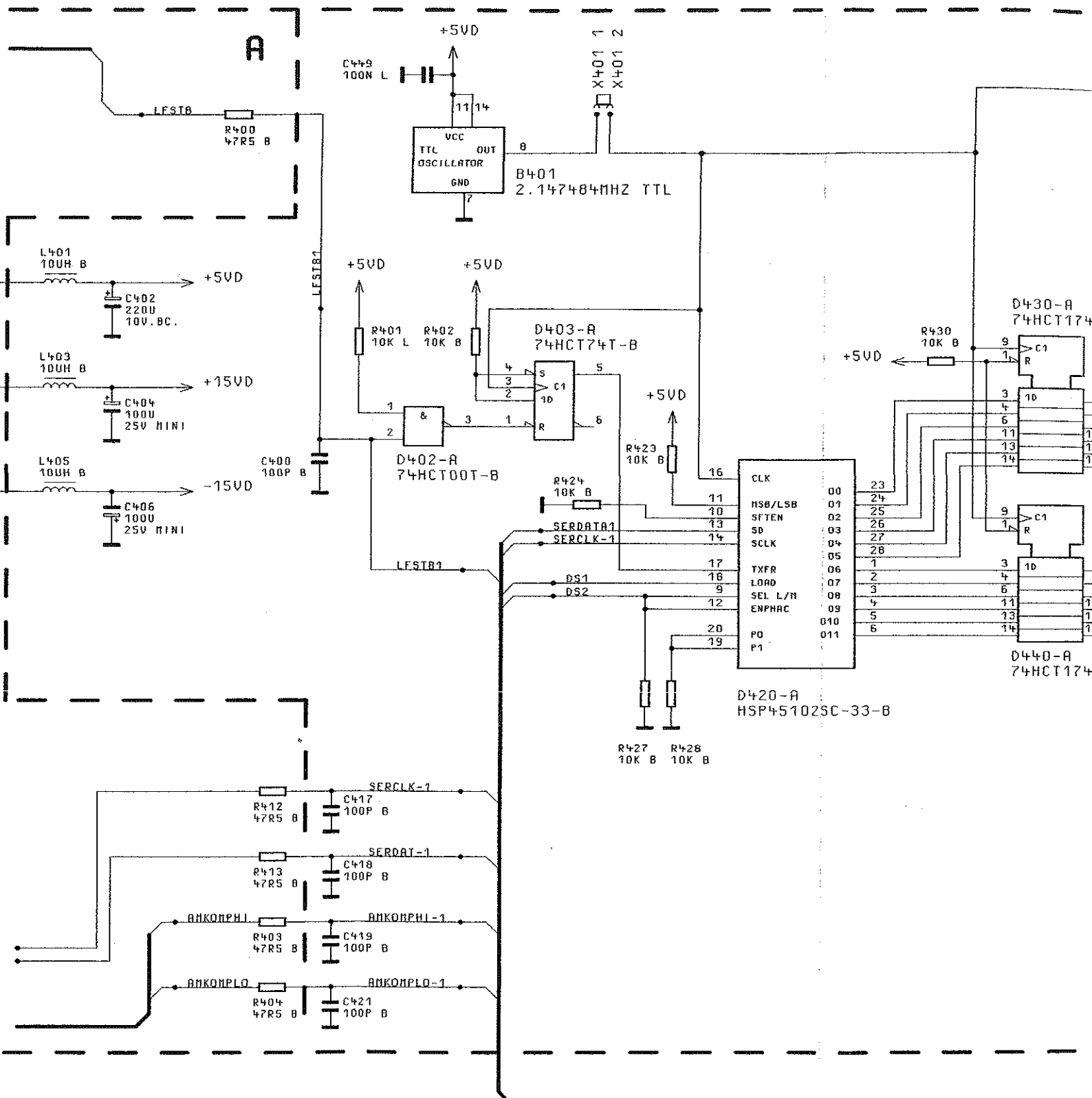

BEHALTEN WIR UNS ALLE RECHTE VOR

STROBE-BUS

A

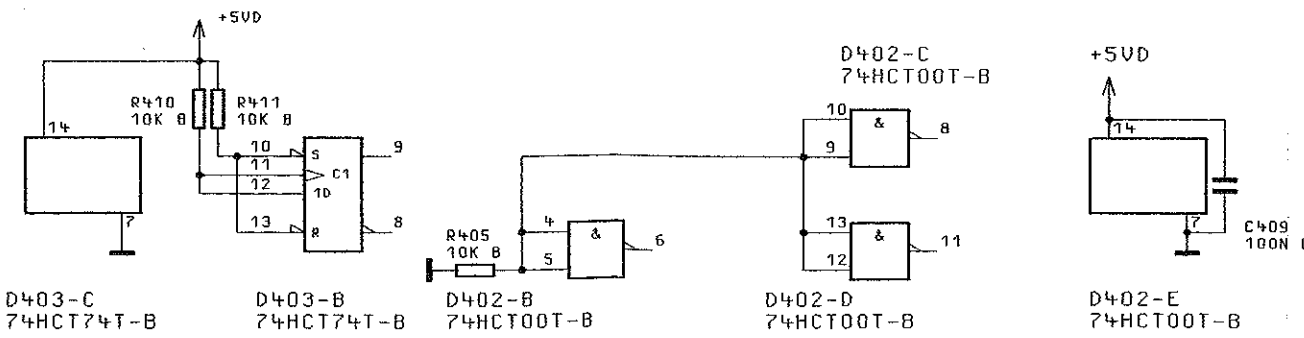
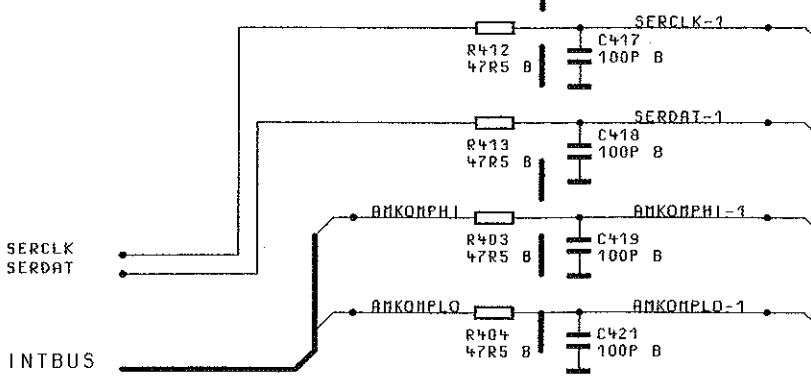
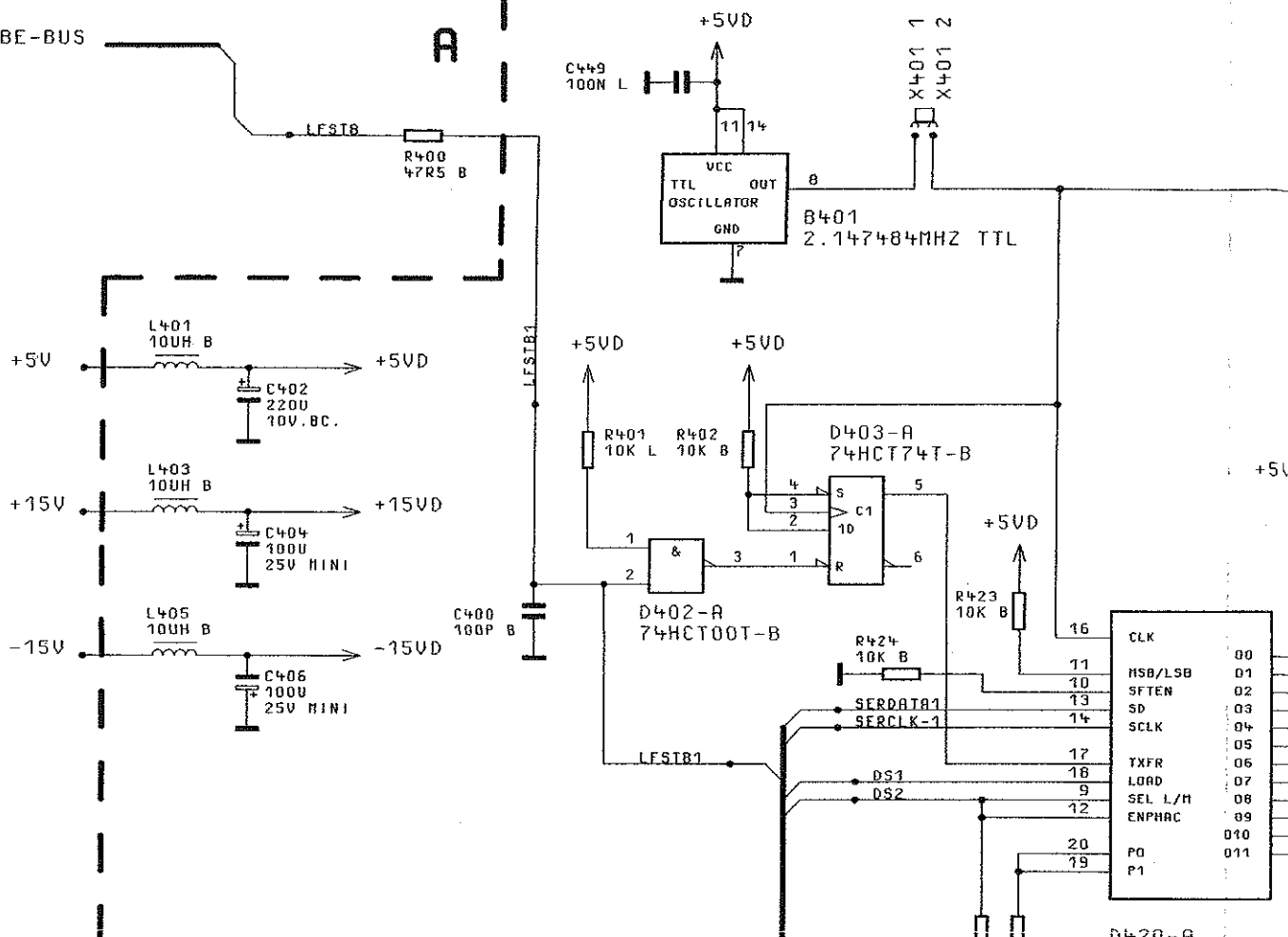

CLK	00
HSB/LSB	01
SFTEN	02
SD	03
SCLK	04
TXFR	05
LOAD	06
SEL L/H	07
ENPHAC	08
P0	010
P1	011

D420-A
HSP451025C-33

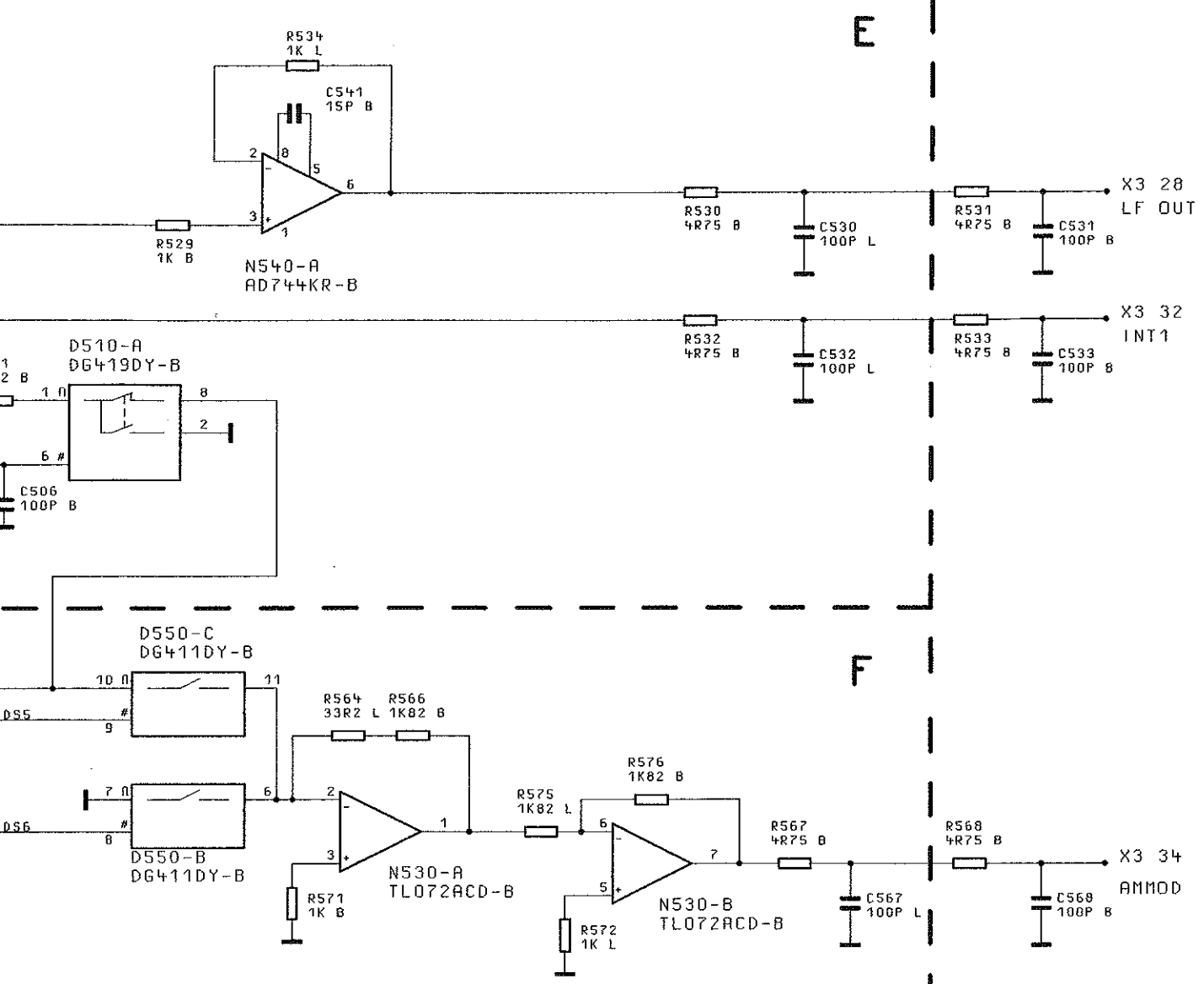

** VAR. 04/MOD. 04



ACHTUNG: EGB!
 ELEKTROSTATISCH GEFÄHRDETE
 BAUELEMENTE ERFORDERN EINE
 BESONDERE HANDHABUNG.
ATTENTION ESD!
 ELECTROSTATIC SENSITIVE DEVICES
 REQUIRE A SPECIAL HANDLING

BINDENDE ANGABEN UEBER VARIANTEN,
 TRIMMWERTE, BAUTEILWERTE UND
 NICHT BESTUECKTE BAUTEILE SIEHE SA.

FOR BINDING INFORMATION ON MODELS,
 TRIMMING AND COMPONENTS VALUES AND
 NONFITTED COMPONENTS SEE PARTS LIST.

* NICHT BESTUECKT
 NOT FITTED

03/04	21.02.97	E I	MENP	TAG	NAME	BENENNUNG		
			BEARB.		E I	RECHNER PROCESSOR		
			GEPR.					
			NORM					
			PLOTT	24.02.97				
02/04	48169	12.01.95	JN	 ROHDE&SCHWARZ		ZEICHN.-NR.		
REND. IND.	ÄNDERUNGS- MITTEILUNG	DATUM	NAME			1062.6309.01S	BLATT-NR. 6	
			ZU GERÄT	SMY	REG. I. V.	1062.5502	ERSTE Z.	1062.5502

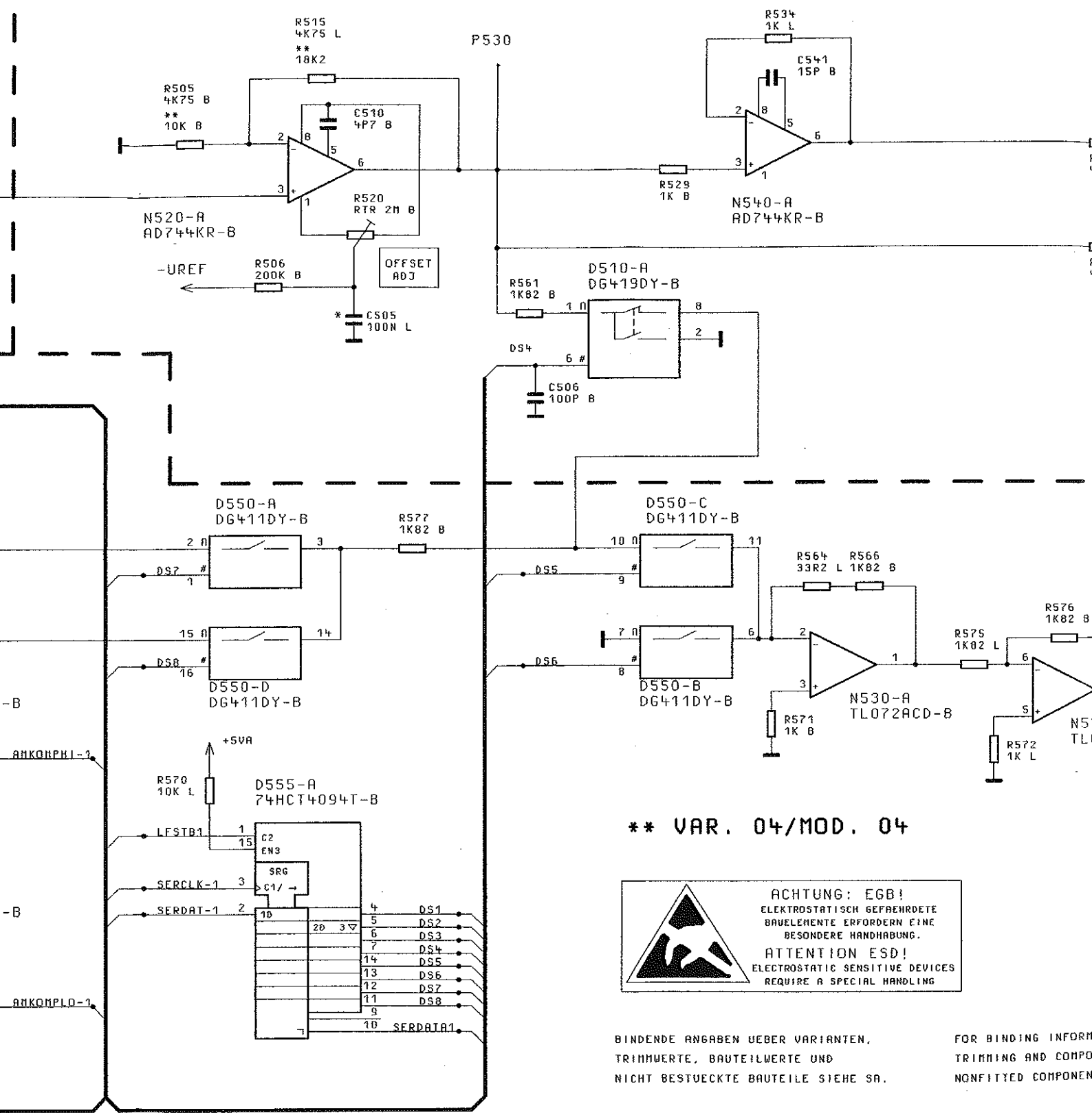

** VAR. 04/MOD. 04



ACHTUNG: EGB!
ELEKTROSTATISCH GEFÄHREDE
BAUELEMENTE ERFORDERN EINE
BESONDERE HANDHABUNG.
ATTENTION ESD!
ELECTROSTATIC SENSITIVE DEVICES
REQUIRE A SPECIAL HANDLING

BINDENDE ANGABEN UEBER VARIANTEN,
TRIMMWERTE, BAUTEILWERTE UND
NICHT BESTUECKTE BAUTEILE SIEHE SA.

FOR BINDING INFORM
TRIMMING AND COMP
NONFITTED COMPONENTS

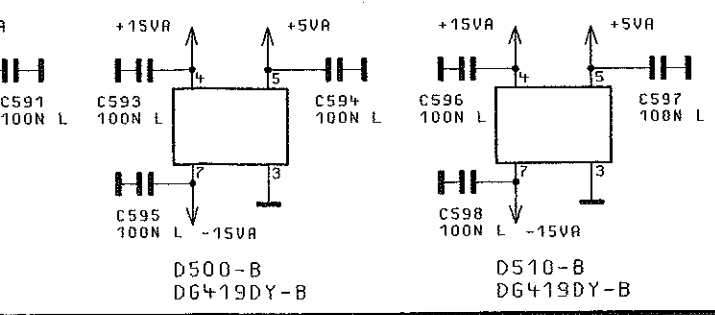

03/01		21.02.97	EI	MENP	TAG	NAME
				BEARB.		EI
				GEPR.		
				NORM		
				PLOTT	24.02.97	
02/04	48169	12.01.95	JN	 ROHDE & SCHWARZ ZU GERÄT SMY		
REND. IND.	ÄNDERUNGS-MITTEILUNG	DATUM	NAMEN			

P510

R520

D

P530

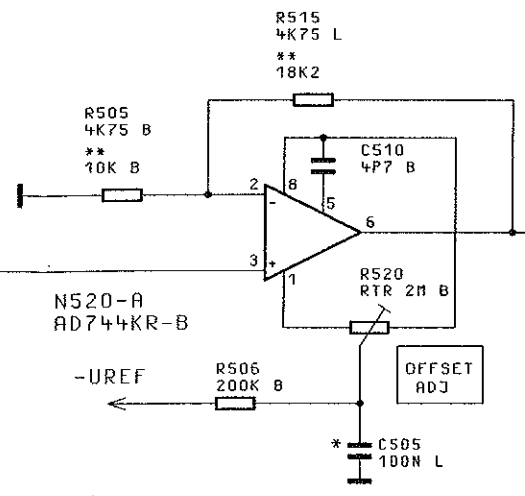
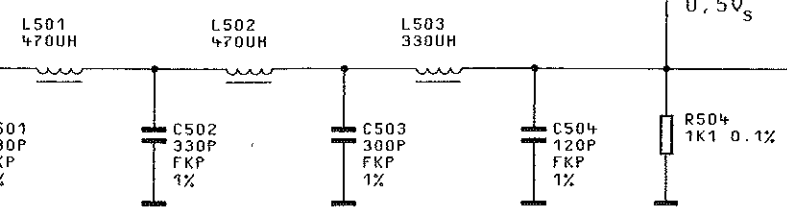

N510-A
NE5534D-B

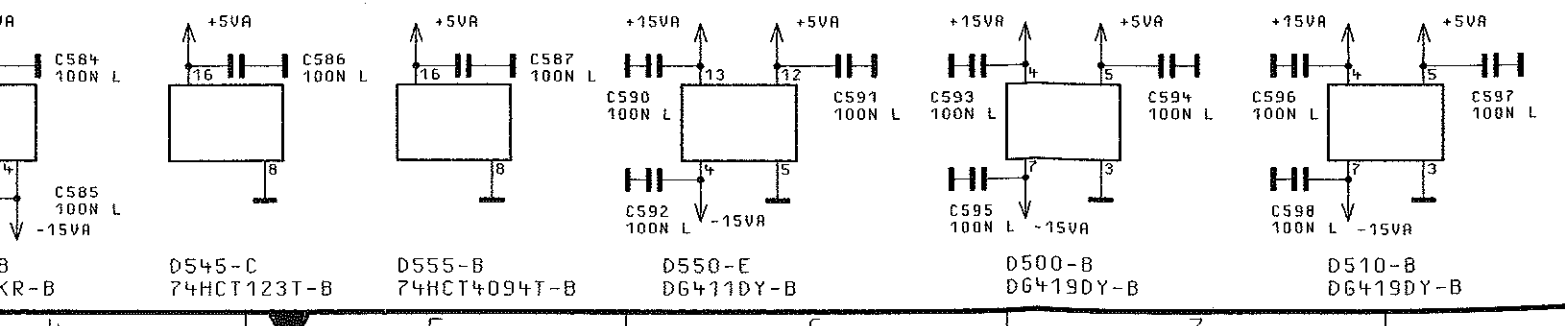
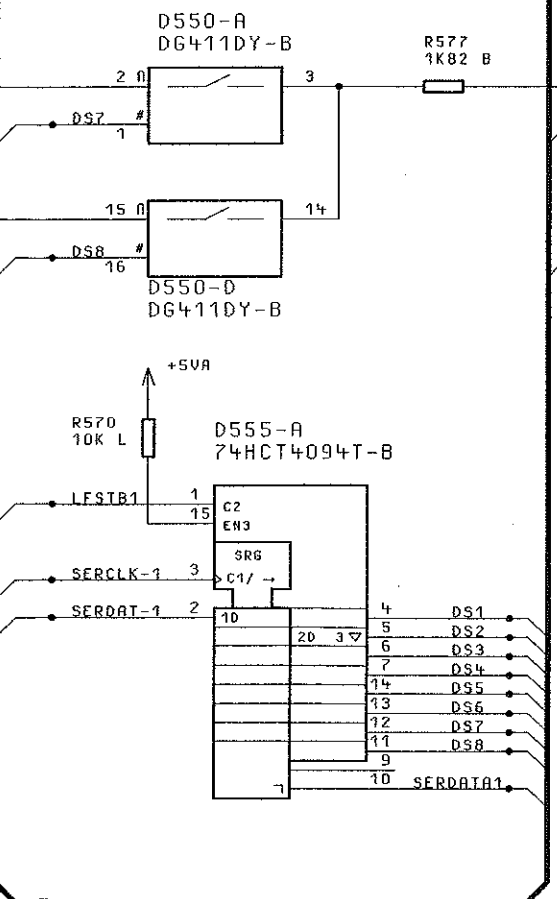
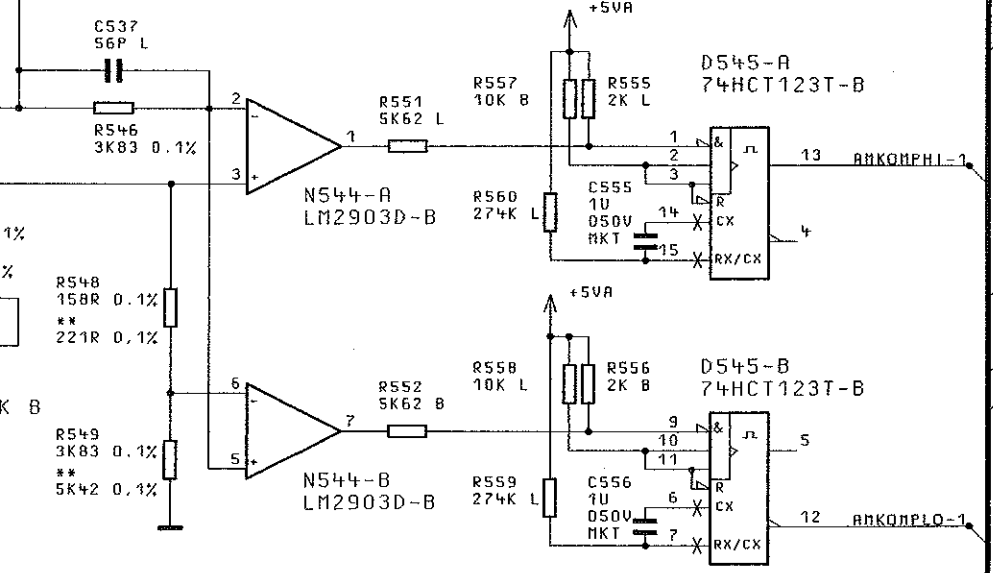
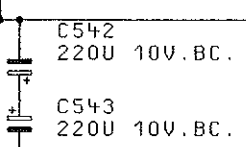

R550 P513

P510

D

P510

0,5V_s

R500 1K1 0.1% L500 3300H L501 4700H L502 4700H L503 3300H

C500 100P FKP 1% C501 330P FKP 1% C502 330P FKP 1% C503 300P FKP 1% C504 420P FKP 1%

R504 1K1 0.1%

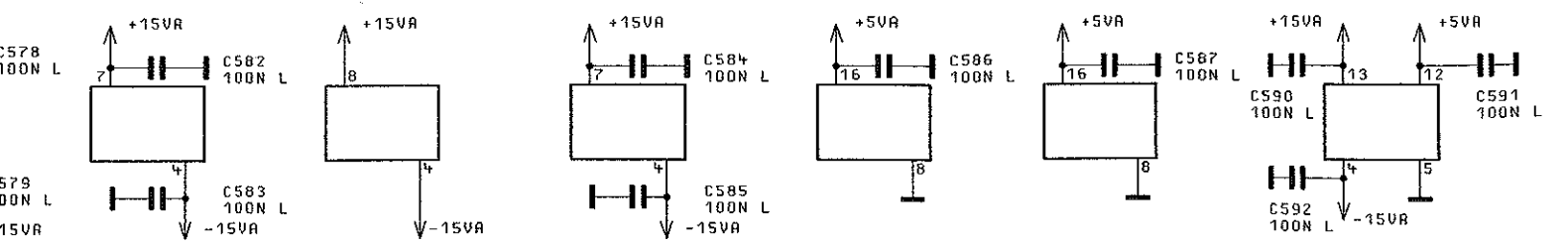
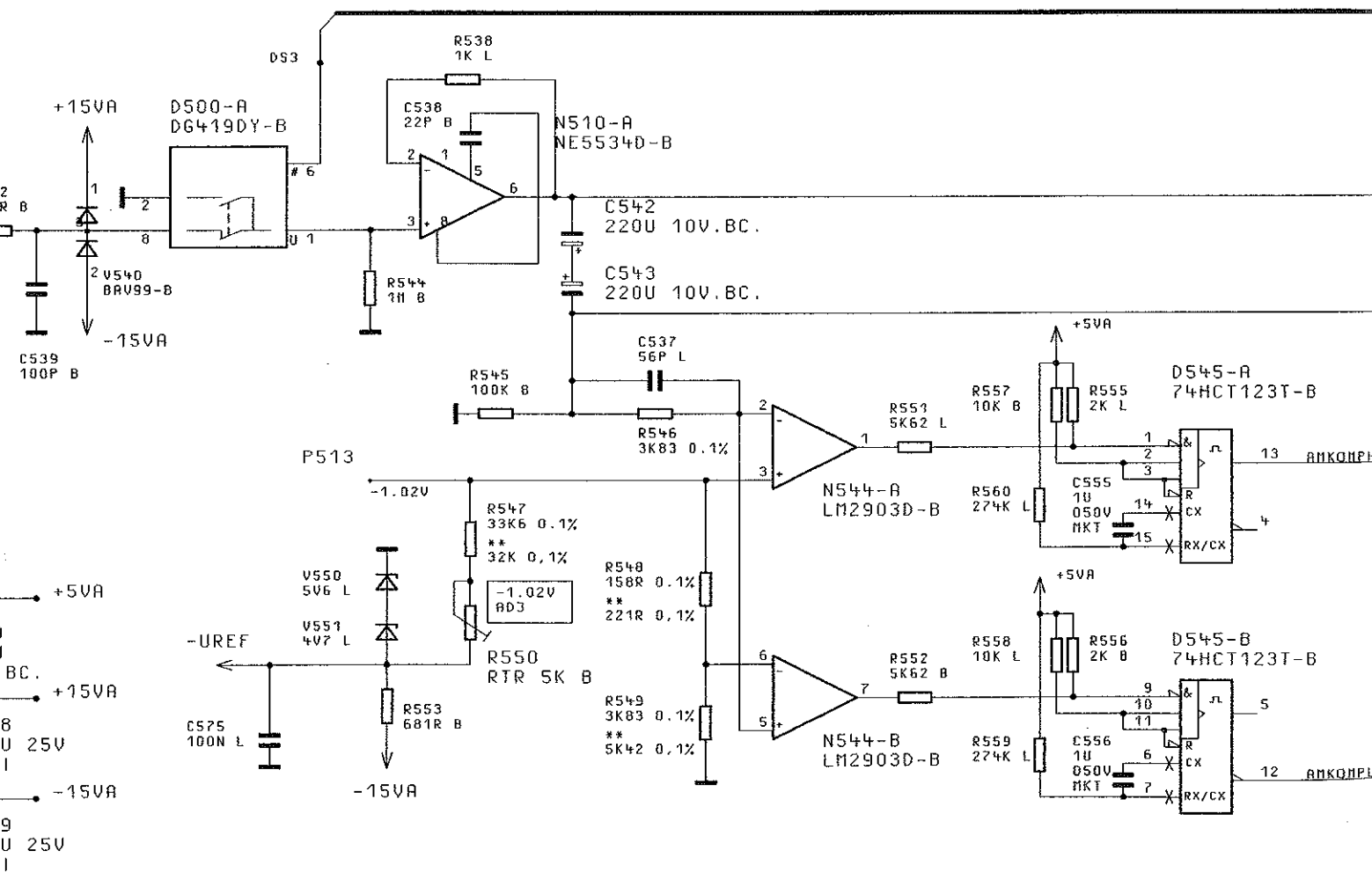

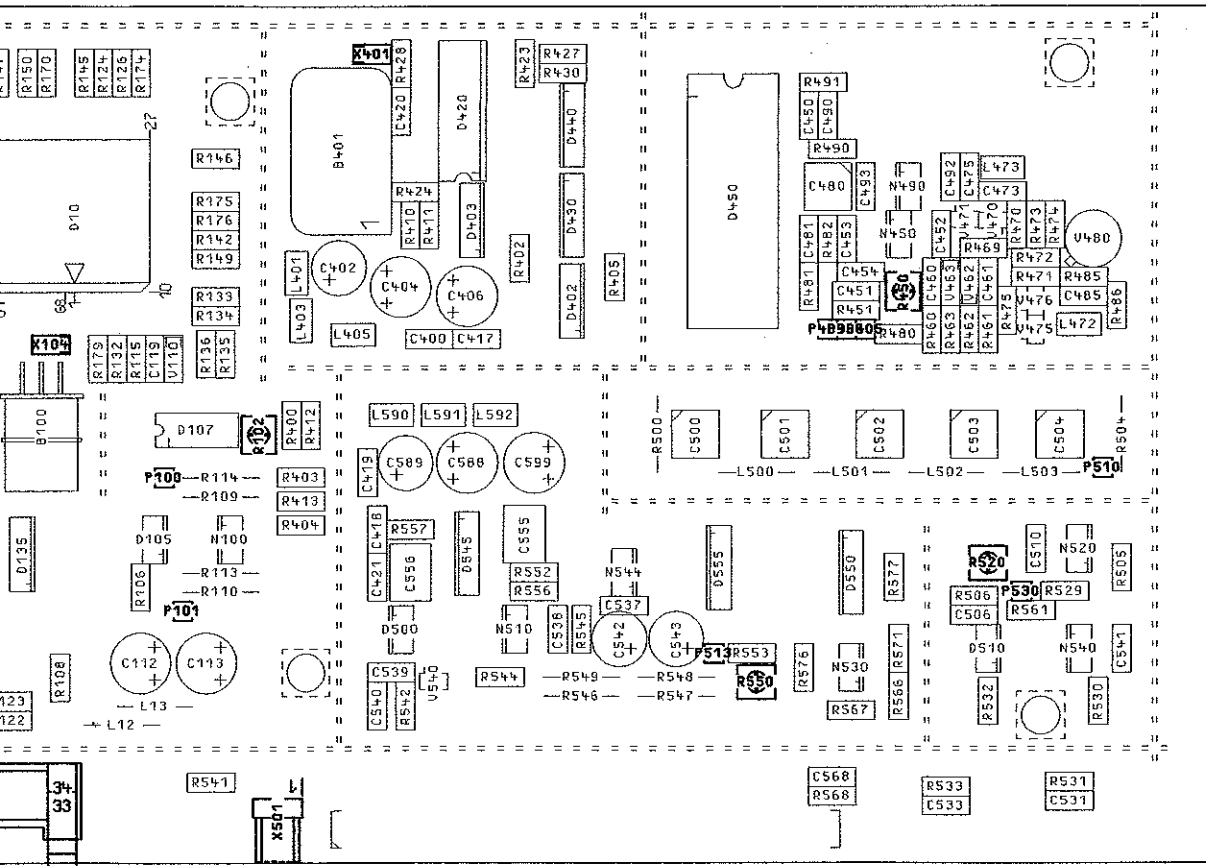

03/01	21.02.97	E I	MEMP	TAG	NARE	BENENNUNG	
			BEARB.		E I	RECHNER PROCESSOR	Z
			GEPR.				
			HGRN				
			PLOTT	21.02.97			
/	48169	29.09.93	HD			ZEICHN.-NR.	BLATT-NR.
BEND.	BENDERUNGS-	DATUM	NAME			1062.6309.01	ED
IND.	MITTEILUNG					1062.5502	1062.5502
			ZU GERÄT	STBY			

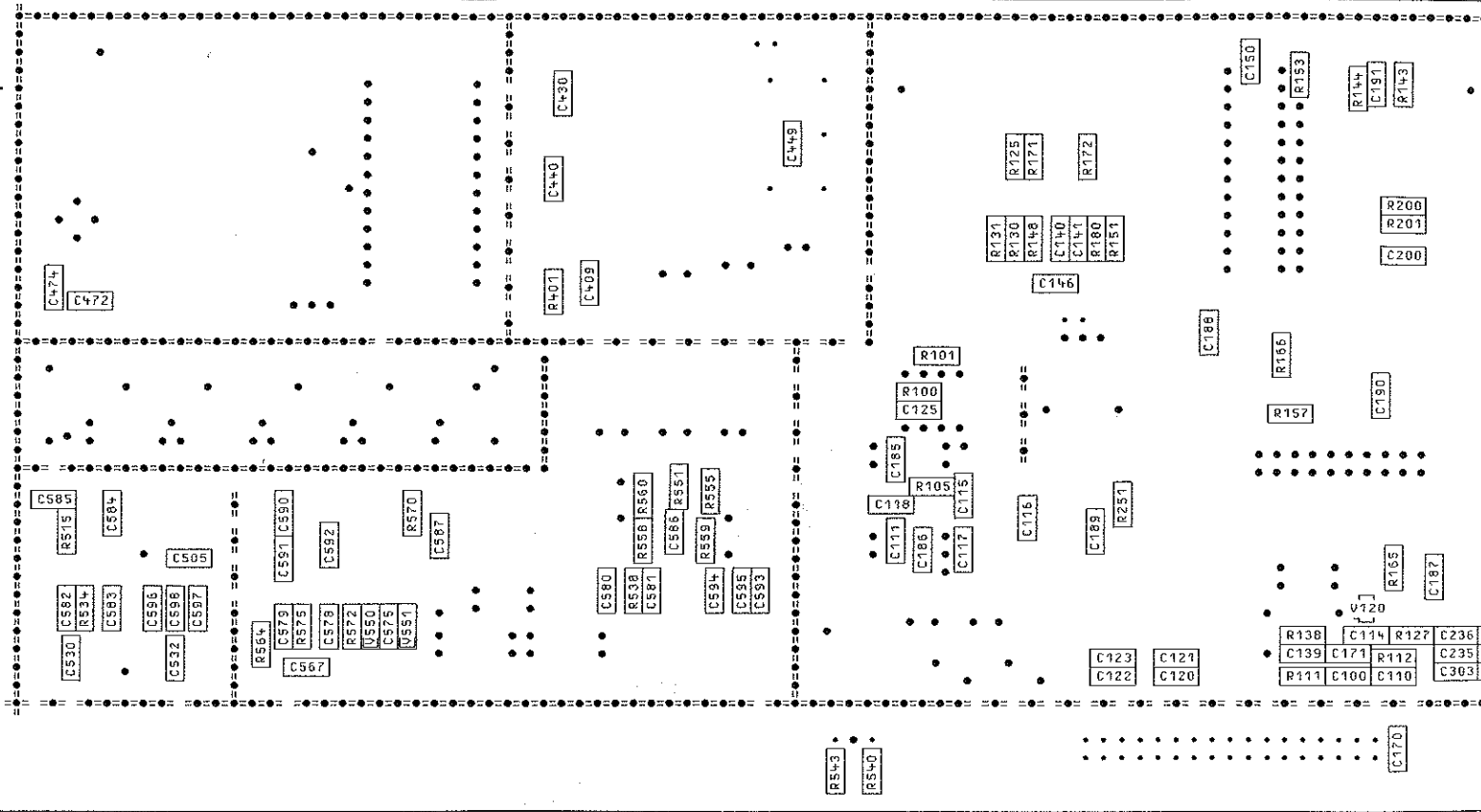

300 250 200 150 100

ITE A



BINDENDE ANGABEN UEBER VARIANTEN, TRAHWERTE, BAUTEILWERTE UND NICHT BESTUECKTE BAUTEILE SIEHE SA.

FOR BINDING INFORMATION ON MODELS, TRIMMING AND COMPONENTS VALUES AND NONFITTED COMPONENTS SEE PARTS LIST.

FÜR DIESE ZEICHNUNG BEHALTEN SICH UNS ALLE RECHTE VOR.
 DIESE ZEICHNUNG IST EIN RECHNERDRUCK. VERÄNDERUNGEN KÖNNEN NUR DURCH WECHSELN DES DATENSATZES ERFOLGEN.

DARSTELLUNG SEITE A
 VIEW ON SIDE A



ACHTUNG: EGB!
 ELEKTROSTATISCH SENSIBELE
 BAUELEMENTE ERFORDERN EINE
 BESONDERE HANDLUNG.
 ATTENTION ESD!
 ELECTROSTATIC SENSITIVE DEVICES
 REQUIRE A SPECIAL HANDLING

BINDENDE ANGABEN ÜBER VARIANTEN,
 TRIMMWERTE, BAUTEILWERTE UND
 NICHT BESTÜCKTE BAUTEILE SIEHE SA.

FOR BINDING INFORMATION ON MODELS,
 TRIMMING AND COMPONENTS VALUES AND
 NONFITTED COMPONENTS SEE PARTS LIST.

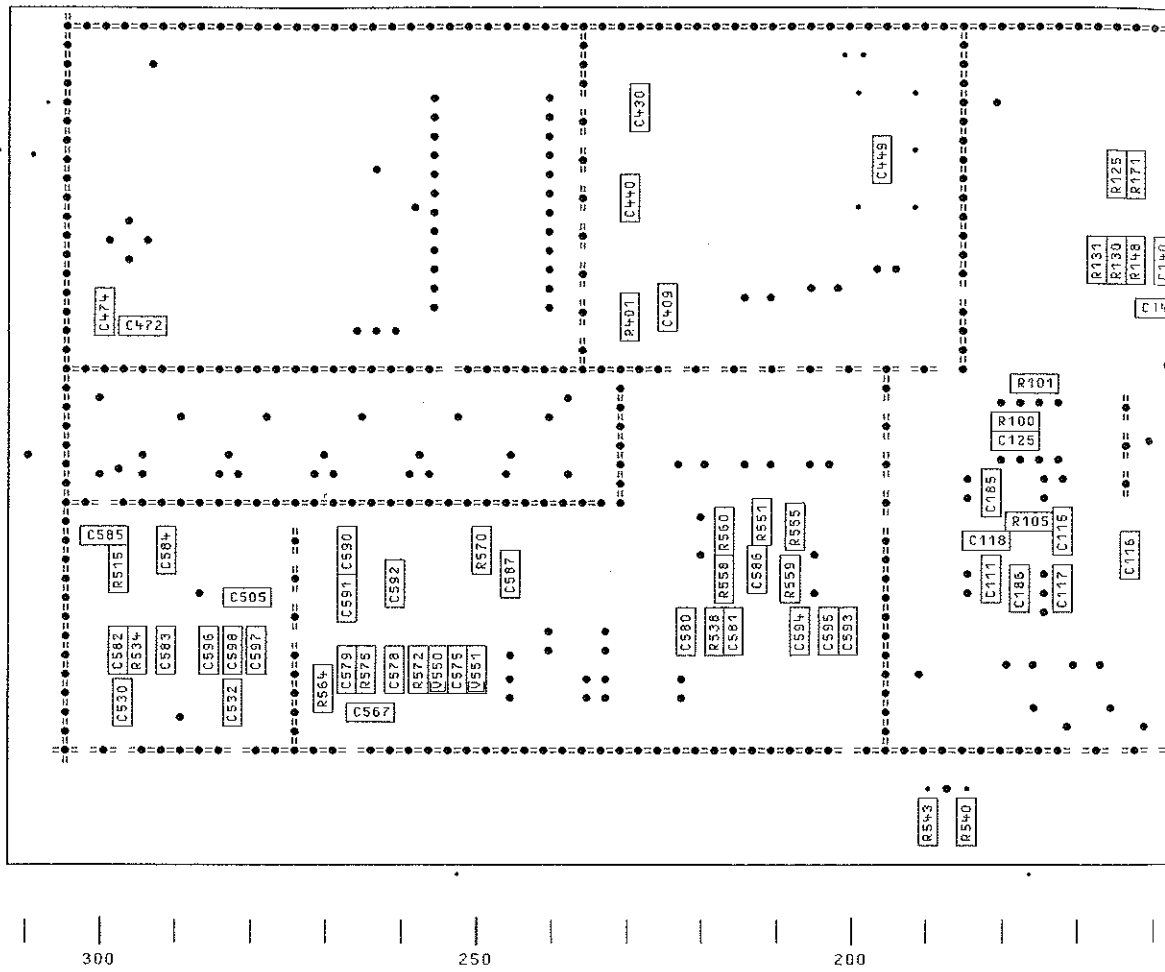



ROHDE&SCHWARZ

SERVICEUNTERLAGEN

ANZEIGE-TASTATUR

1062.6809.02

Inhaltsverzeichnis

7	Prüfen und Instandsetzen der Baugruppe.....	5
7.1	Funktionsbeschreibung.....	5
7.1.1	Tastaturmatrix.....	5
7.1.2	Drehimpulsgeber.....	5
7.1.3	Anzeigen.....	5
7.2	Meßgeräte und Hilfsmittel.....	5
7.3	Fehlersuche.....	6
7.4	Prüfen und Abgleich.....	6
7.4.1	Prüfen der Stromversorgung.....	6
7.4.2	Prüfen der Tastaturmatrix.....	6
7.4.3	Prüfen des Drehimpulsgebers.....	6
7.4.4	Abgleich der LCD-Ansteuerung.....	6
7.4.5	Prüfung der LCD- und LED-Ansteuerung.....	7
7.5	Zerlegung und Zusammenbau.....	7
7.6	Externe Schnittstelle.....	7

Schaltteilliste
Koordinatenliste
Stromlauf
Bestückungsplan

7.1 Funktionsbeschreibung

Die Baugruppe besteht aus der Tastaturmatrix, Drehimpulsgeber und dem Anzeigeteil.

7.1.1 Tastaturmatrix

Die Eingabetasten des Gerätes sind an den Kreuzungspunkten einer Matrix angeordnet, deren Zeilen- und Spaltenleitungen mit einer Auswerteschaltung auf der Rechner-Baugruppe verbunden sind. Beim Betätigen einer Taste wird die Zeile, in der die Taste angeordnet ist, mit der ihr zugeordneten Spalte verbunden, wodurch auf der Rechner-Baugruppe ein Interrupt erzeugt wird, der den Rechner veranlasst, einen für diese Tastenstellung charakteristischen Code über den Datenbus einzulesen.

Den Parametertasten, SPEC- und der STATUS-Tasten sind Leuchtdioden zugeordnet, die zur Vereinfachung der Bedienung die zuletzt betätigte Taste anzeigen. Eine weitere LED dient als REMOTE-Anzeige. Die Ansteuerung der Tastatur-LEDs erfolgt über den Schieberegisterbausteine D3 und D4.

7.1.2 Drehimpulsgeber

Mit dem Drehimpulsgeber kann der jeweils aktivierte Parameter kontinuierlich variiert werden.

Der Drehimpulsgeber mit beiden Hallgeneratoren liefert zwei Pulsfolgen die je nach der Drehrichtung eine Phasendifferenz von + oder - 90 Grad haben. Die nachfolgende Schaltung wertet diese Phasendifferenz als Richtungserkennung aus.

Die Impulse steuern einen Schalter der den + oder - Tastendruck simuliert. Die Variationsschrittweite kann für jeden Parameter einzeln eingegeben werden.

7.1.3 Anzeigen

Zur Anzeige der aktuellen Geräteeinstellung besitzt das Gerät zwei LCD-Anzeigen, das Frequenz-Display sowie ein kombiniertes Amplituden-/Modulations-Display. Die Ansteuerung der Segmente der beiden Displays (H10, H20) erfolgt im Multiplexverfahren durch je einen Ansteuerbaustein (D1, D2).

Der Datenverkehr zwischen der Baugruppe Rechner und Anzeige/Tastatur erfolgt seriell. Die LCD-Anzeigen sind, um ihre Ablesbarkeit bei dunklen Umgebungsverhältnissen zu gewährleisten, hinterleuchtet. Der Kontrast der Segmente läßt sich mit R15 abgleichen.

7.2 Meßgeräte und Hilfsmittel

- Digitalmultimeter (z.B. R&S UDS5)
- Oszilloskop

7.3 Fehlersuche

Anzeige bleibt dunkel	Betriebsspannungen (siehe Schnittstellen) und Verkabelung überprüfen.
Kontrast der Anzeige mangelhaft	Abgleich nach 7.4.4
Keine Reaktion auf Tastendruck	Taste überprüfen. Erfolgt keine Reaktion beim Betätigen von Tasten, so ist zu überprüfen, ob eine Taste festsetzt.
Keine Reaktion bei Betätigen des Drehimpulsgebers	Hallgenerator prüfen. Erfolgt keine Reaktion beim Betätigen so ist zu überprüfen, ob eine Taste festsetzt.

7.4 Prüfen und Abgleich

Alle Meßwerte ohne Toleranzangaben sind als Richtwerte zu verstehen. Spannungen ohne weitere Bezeichnungen bedeuten DC-Spannungen.

7.4.1 Prüfen der Stromversorgung

- Ein Amperemeter in die Versorgungsleitungen der einzelnen Versorgungsspannungen einschleifen.
- _ Die Stromaufnahme der Baugruppe überprüfen. Die Sollwerte zu den jeweiligen Versorgungsspannungen sind unter "Externe Schnittstellen" zu finden.

7.4.2 Prüfen der Tastaturmatrix

- _ Die einzelnen Tasten der Tastenmatrix auf gute Kontaktgabe prüfen. Maximaler Widerstand gemessen an X1: $< 2 \Omega$.
- _ Die Tastaturmatrix ist auf Kurzschluß zu prüfen.

7.4.3 Prüfen des Drehimpulsgebers

- An X1.24 und X1.26 Oszilloskop anschließen.
- Drehimpulsgeber in beide Richtungen drehen.
- _ Am Oszilloskop müssen Impulse zu sehen sein.

7.4.4 Abgleich der LCD-Ansteuerung

- _ R15 so einstellen, daß sich aus frontaler Sicht auf das Display ein guter Kontrast ergibt, ohne daß aus einem Winkel von ca. 30 Grad die nicht angesteuerten Segmente sichtbar werden.

7.4.5 Prüfung der LCD- und LED-Ansteuerung

- Die Spezialfunktion 31 einschalten.
- _ LCD-Segmente und LED auf Funktion überprüfen.

7.5 Zerlegung und Zusammenbau

Nach dem Öffnen des Gerätes und dem Lösen der Schrauben auf der Frontplatte kann die Baugruppe aus dem Rahmen herausgenommen werden. Die Verbindung mit dem Gerät ist weiterhin über Flachbandkabel vorhanden, so daß die Baugruppe für Messungen zugänglich ist. Der Einbau der Baugruppe und Zusammenbau des Gerätes erfolgt entsprechend in umgekehrter Reihenfolge.

7.6 Externe Schnittstelle

Pin	Name	Ein/Ausgang	Herkunft/Ziel	Wertebereich	Signalbeschreibung
X1.1	VA5-P	Eingang	A2 CPU X1.1	+4.9V..5.3V max.0.2A	+5V Versorgungsspannung
X1.2	SERCLK	Eingang	A2 CPU X1.2	HCMOS-Pegel	Seriell-Clock
X1.3	VA5-P	Eingang	A2 CPU X1.3	+4.9V..5.3V max.0.2A	+5V Versorgungsspannung
X1.4	SERDATA	Eingang	A2 CPU X1.4	HCMOS-Pegel	Seriell-Daten
X1.6	DIS1STB	Eingang	A2 CPU X1.6	HCMOS-Pegel	Display Strobe 1
X1.8	DIS2STB	Eingang	A2 CPU X1.8	HCMOS-Pegel	Display Strobe 2
X1.10	LEDSTB	Eingang	A2 CPU X1.10	HCMOS-Pegel	LED-Strobe
X1.11	COL7	Ausgang	A2 CPU X1.11	HCMOS-Pegel	Tasten-Code
X1.12	C/D#	Eingang	A2 CPU X1.12	HCMOS-Pegel	Steuersignal
X1.13	COL6	Ausgang	A2 CPU X1.13	HCMOS-Pegel	Tasten-Code
X1.14	DISBUSY#	Ausgang	A2 CPU X1.14	HCMOS-Pegel	Steuersignal
X1.15	COL5	Ausgang	A2 CPU X1.15	HCMOS-Pegel	Tasten-Code
X1.16	RES	Eingang	A2 CPU X1.16	HCMOS-Pegel	Reset
X1.17	COL4	Ausgang	A2 CPU X1.17	HCMOS-Pegel	Tasten-Code
X1.18	ROW5	Ausgang	A2 CPU X1.18	HCMOS-Pegel	Tasten-Code
X1.19	COL3	Ausgang	A2 CPU X1.19	HCMOS-Pegel	Tasten-Code
X1.20	ROW4	Ausgang	A2 CPU X1.20	HCMOS-Pegel	Tasten-Code
X1.21	COL2	Ausgang	A2 CPU X1.21	HCMOS-Pegel	Tasten-Code
X1.22	ROW3	Ausgang	A2 CPU X1.22	HCMOS-Pegel	Tasten-Code
X1.23	COL1	Ausgang	A2 CPU X1.23	HCMOS-Pegel	Tasten-Code
X1.24	ROW2	Ausgang	A2 CPU X1.24	HCMOS-Pegel	Tasten-Code
X1.25	COL0	Ausgang	A2 CPU X1.25	HCMOS-Pegel	Tasten-Code
X1.26	ROW1	Ausgang	A2 CPU X1.26	HCMOS-Pegel	Tasten-Code

GND X1.5\7\9



ROHDE & SCHWARZ

SERVICE INSTRUCTIONS

Display-Keyboard

1062.6809.02

Contents

7 Testing and Repair of the Module..... 5

 7.1 Function Description..... 5

 7.1.1 Keyboard Matrix..... 5

 7.1.2 Spinwheel..... 5

 7.1.3 Displays..... 5

 7.2 Test Instruments and Utilities..... 5

 7.3 Troubleshooting..... 6

 7.4 Testing and Adjustment..... 6

 7.4.1 Testing the Power Supply..... 6

 7.4.2 Testing the Keyboard Matrix..... 6

 7.4.3 Testing the Spinwheel..... 6

 7.4.4 Adjusting the LCD Control..... 6

 7.4.5 Testing Control of LCDs and LEDs..... 7

 7.5 Disassembly and Assembly..... 7

 7.6 External Interfaces..... 7

Parts list
List of coordinates
Circuit diagram
Component layout diagram

7.1 Function Description

The module consists of the keyboard matrix, spinwheel and the display unit.

7.1.1 Keyboard Matrix

The keys of the instrument are assigned to cross-points of a matrix, the vertical and horizontal lines of which are connected to an evaluation logic on the controller board.

When a key is pressed, the vertical line this key is assigned to, is connected to the corresponding vertical line, thus triggering an interrupt on the controller board, which causes the controller to read in the code characteristic for this key arrangement via the data bus.

The parameter keys, SPEC keys and STATUS keys are assigned LEDs which indicate the key which was last pressed thus ensuring high operating ease. Another LED indicates the REMOTE state. The keyboard LEDs are addressed via the shift-register components D3 and D4.

7.1.2 Spinwheel

The spinwheel enables continuous variation of the activated parameter.

In conjunction with two Hall generators, the spinwheel generates two pulse sequences with a phase difference of +90 or -90 degrees. The subsequent circuit determines the direction by evaluating this phase difference.

The pulses control a switch simulating the keystrokes + or -. The variation-step size can be entered individually for each parameter.

7.1.3 Displays

The instrument provides two LCD displays indicating the current instrument setting, the frequency display and an amplitude/modulation display. The segments of the two displays (H10, H20) are addressed by one controller component each (D1, D2) which are multiplexed.

Data are transmitted serially between the controller module and the display/keyboard module. The LCD displays have a bright, illuminated background to ensure easy reading even in dark environments. The contrast of the segments can be adjusted using R15.

7.2 Test Instruments and Utilities

- Digital multimeter (e.g., R&S UDS5)
- Oscilloscope

7.3 Troubleshooting

Display remains dark	Check operating voltages (see interfaces) and cabling.
Poor contrast of display	Adjust acc. to 7.4.4
No reaction upon keystroke	Check key. If keystrokes do not cause any reaction, check, whether any key has got stuck.
No reaction upon actuating the spinwheel	Check Hall generator. If no reaction is caused by actuating the spinwheel, check, whether any key has got stuck.

7.4 Testing and Adjustment

All measured values indicated without tolerances are recommended values. Voltages given without any further detail are dc voltages.

7.4.1 Testing the Power Supply

- Connect an ammeter into the supply lines of the supply voltages.
- _ Check the power consumption of the module. The rated values of the individual supply voltages can be looked up under "External Interfaces".

7.4.2 Testing the Keyboard Matrix

- _ Check the contacting of the individual keys of the keyboard matrix. Maximum resistance measured at X1: $< 2 \Omega$.
- Check the keyboard matrix with regard to short-circuit.

7.4.3 Testing the Spinwheel

- Connect an oscilloscope to X1.24 and X1.26.
- Turn the spinwheel into both directions.
- _ Pulses must be visible on the oscilloscope.

7.4.4 Adjusting the LCD Control

- _ Adjust R15 such that a good contrast is obtained with frontal view on the display without the non-addressed segments becoming visible from an angle of 30 degrees.

7.4.5 Testing Control of LCDs and LEDs

- Switch on special function 31.
- _ Check function of LCD segments and LEDs.

7.5 Disassembly and Assembly

Subsequent to opening the instrument and undoing the screws on the front panel, the module can be removed from the frame. The module is still connected to the instrument via ribbon cables, thus being accessible for measurements.

Installation of the module and reassembly of the instrument are carried out in the reverse order.

7.6 External Interfaces

Pin	Name	Input/Output	Origin/Dest-	Specified range	Signal description
X1.1	VA5-P	Input	A2 CPU X1.1	+4.9.5.3V max.0.2A	+5V supply voltage
X1.2	SERCLK	Input	A2 CPU X1.2	HCMOS level	Serial clock
X1.3	VA5-P	Input	A2 CPU X1.3	+4.9.5.3V max.0.2A	+5V supply voltage
X1.4	SERDATA	Input	A2 CPU X1.4	HCMOS level	Serial data
X1.6	DIS1STB	Input	A2 CPU X1.6	HCMOS level	Display strobe 1
X1.8	DIS2STB	Input	A2 CPU X1.8	HCMOS level	Display strobe 2
X1.10	LEDSTB	Input	A2 CPU X1.10	HCMOS level	LED strobe
X1.11	COL7	Output	A2 CPU X1.11	HCMOS level	Key code
X1.12	C/D#	Input	A2 CPU X1.12	HCMOS level	Control signal
X1.13	COL6	Output	A2 CPU X1.13	HCMOS level	Key code
X1.14	DISBUSY#	Output	A2 CPU X1.14	HCMOS level	Control signal
X1.15	COL5	Output	A2 CPU X1.15	HCMOS level	Key code
X1.16	RES	Input	A2 CPU X1.16	HCMOS level	Reset
X1.17	COL4	Output	A2 CPU X1.17	HCMOS level	Key code
X1.18	ROW5	Output	A2 CPU X1.18	HCMOS level	Key code
X1.19	COL3	Output	A2 CPU X1.19	HCMOS level	Key code
X1.20	ROW4	Output	A2 CPU X1.20	HCMOS level	Key code
X1.21	COL2	Output	A2 CPU X1.21	HCMOS level	Key code
X1.22	ROW3	Output	A2 CPU X1.22	HCMOS level	Key code
X1.23	COL1	Output	A2 CPU X1.23	HCMOS level	Key code
X1.24	ROW2	Output	A2 CPU X1.24	HCMOS level	Key code
X1.25	COL0	Output	A2 CPU X1.25	HCMOS level	Key code
X1.26	ROW1	Output	A2 CPU X1.26	HCMOS level	Key code

GND X1.5\7\9

Schaltteillisten
numerisch geordnet
Part lists
in numerical order
Listes des pièces détachées
par numéros de référence

XY-Liste

XY List

Erklärung der Spaltenbezeichnungen:

- Part:** Bauelement-Kennzeichen.
- Side:** Leiterplatten-Seite, auf der sich das Bauelement befindet.
- X/Y:** Koordinaten (Millimeter) des Bauelementes auf der Leiterplatte bezogen auf den Nullpunkt.
- SQR, PG:** Planquadrat und Seite des Schaltbildes für das jeweilige Bauelement.

Explanation of column designations:

- Part:** Identification of instrument part.
- Side:** Side of the PC board on which instrument part is positioned.
- X/Y:** Coordinates (millimeter) of the component on the PC board in reference to zero point.
- SQR, PG:** Square and page of the diagram for the respective instrument part.

Für diese Unterteile behalten wir uns alle Rechte vor.

Kennz. Comp. No.	Benennung Designation	Sachnummer Stock No.	Hersteller Manufacturer	Bezeichnung Designation	enthalten in contained in	
B1	BS UGN3120U HALL-EFF.SW. HALL-EFF.SWITCH	BJ 0336.4750.00	ALLEGRO	A3144EU		
B2	BS UGN3120U HALL-EFF.SW. HALL-EFF.SWITCH	BJ 0336.4750.00	ALLEGRO	A3144EU		
C1	CC 1NF+-1% 50V NPO 1206 SMD CERAMIC CAPACITOR	CC 0007.7398.00	PHILIPS_CO	2222 863 *8102		
C5	CC 100NF+-10%50V X7R 1206 CERAMIC CHIP CAPACITOR	CC 0007.5237.00	PHILIPS_CO	2238 581 15649		
C8	CC 2,2NF+-10%50VX7R 1206 CERAMIC CHIP CAPACITOR	CC 0099.8444.00	PHILIPS_CO	2222 581 16618		
C9	CE 4,7U F+-10% 10V 3528 TANTALUM SMD-CAPACITOR	CE 0007.7275.00	SPRAGUE	293D 475 X9 010 B2T		
C11	CC 100NF+-10%50V X7R 1206 CERAMIC CHIP CAPACITOR	CC 0007.5237.00	PHILIPS_CO	2238 581 15649		
C20	CC 100NF+-10%50V X7R 1206 CERAMIC CHIP CAPACITOR	CC 0007.5237.00	PHILIPS_CO	2238 581 15649		
C21	CC 100NF+-10%50V X7R 1206 CERAMIC CHIP CAPACITOR	CC 0007.5237.00	PHILIPS_CO	2238 581 15649		
D1	BJ UPD7225G00 LCD DRIV ALPHANUM.LCD CONTR/DRIVER	BJ 0392.5320.00	NEC	D7225G (JG)		
D2	BJ UPD7225G00 LCD DRIV ALPHANUM.LCD CONTR/DRIVER	BJ 0392.5320.00	NEC	D7225G (JG)		
D3	BL PC74HC4094T 8ST.BUSREG BUS REGISTER	BL 0804.0977.00	PHILIPS_SE	(PC)74HC4094(D/T)		
D4	BL PC74HC4094T 8ST.BUSREG BUS REGISTER	BL 0804.0977.00	PHILIPS_SE	(PC)74HC4094(D/T)		
D5	BL PC74HCT86T 4X2IN.EXOR EXOR GATE	BL 0007.6291.00	PHILIPS_SE	(PC)74HCT86(D/T)		
D6	BL PC74HCT74T 2XD-FLIPFL DUAL D-TYPE FLIP FLOP	BL 0007.6262.00	PHILIPS_SE	(PC)74HCT74D(T)		
D7	BL PC74HCT08T 4X2IN ANDG AND GATE	BL 0007.6179.00	PHILIPS_SE	(PC)74HCT08(D/T)		
D8	BL PC74HCT4066T 4XASWITCH ANALOG SWITCH	BL 0007.6862.00	PHILIPS	(PC)74HCT4066(T)		
H1	EF T1 5V 0,06A D.SOCKEL GLOW LAMP	EF 0234.4375.00	OSHINO	OL-683		
H10	BP AN 127 LCD-MODULE	0826.8587.00	VARITRONIX	R&S 0826.8587		
H20	BP AN 126 LCD-MODULE	0826.8570.00	VARITRONIX	R&S 0826.8570		
JS1	SB TASTENKAPPE 6X10,5 HGR CAP 6X10,5 HGR	SB 0396.0122.00	DEKORSY	R&S.ZCHNG.396.0122		
JS4	SB TASTENKAP.6X10,5 BLAU PUSHBUTTON	SB 0396.0174.00	DEKORSY	R&S.ZCHNG.396.0174		
JS5	SB TASTENKAPPE 6X10,5 HGR CAP 6X10,5 HGR	SB 0396.0122.00	DEKORSY	R&S.ZCHNG.396.0122		
JS11	SB KAPPE GR 10,5X10,5 PUSHBUTTON	SB 0396.0045.00	DEKORSY	R&S.ZCHNG.396.0045		
JS12	SB KAPPE GR 10,5X10,5 PUSHBUTTON	SB 0396.0045.00	DEKORSY	R&S.ZCHNG.396.0045		
JS13	SB KAPPE GR 10,5X10,5 PUSHBUTTON	SB 0396.0045.00	DEKORSY	R&S.ZCHNG.396.0045		
JS14	SB TASTENKAPPE 6X10,5 HGR CAP 6X10,5 HGR	SB 0396.0122.00	DEKORSY	R&S.ZCHNG.396.0122		
JS18	SB KAPPE HGR. 10,5X10,5"0" CAP "0"	SB 0396.0216.00	DEKORSY	R&S.ZCHNG.396.0216		
JS19	SB KAPPE HGR. 10,5X10,5"1" CAP "1"	SB 0396.0222.00	DEKORSY	R&S.ZCHNG.396.0222		
JS20	SB KAPPE HGR. 10,5X10,5"4" CAP "4"	SB 0396.0251.00	DEKORSY	R&S.ZCHNG.396.0251		
JS21	SB KAPPE HGR. 10,5X10,5"7" PUSHBUTTON	SB 0396.0280.00	DEKORSY	R&S.ZCHNG.396.0280		
JS22	SB KAPPE HGR. 10,5X10,5". " CAP HGR. 10,5X10,5". "	SB 0396.0339.00	DEKORSY	R&S.ZCHNG.396.0339		
JS23	SB KAPPE HGR. 10,5X10,5"2" CAP "2"	SB 0396.0239.00	DEKORSY	R&S.ZCHNG.396.0239		
JS24	SB KAPPE HGR. 10,5X10,5"5" CAP "5"	SB 0396.0268.00	DEKORSY	R&S.ZCHNG.396.0268		
JS25	SB KAPPE HGR. 10,5X10,5"8" PUSHBUTTON	SB 0396.0297.00	DEKORSY	R&S.ZCHNG.396.0297		
JS26	SB KAPPE HGR. 10,5X10,5"- " CAP HGR. 10,5X10,5"- "	SB 0396.0322.00	DEKORSY	R&S.ZCHNG.396.0322		
JS27	SB KAPPE HGR. 10,5X10,5"3" CAP "3"	SB 0396.0245.00	DEKORSY	ZEICHNUNG 396.0245		
MENP5	413 3PUA	Ät	Datum Date	Schaltteilliste für Parts list for	Sachnummer Stock No.	Blatt-Nr. Page
	ROHDE & SCHWARZ	06	16.09.97	ED TASTATUR/ANZEIGE KEYBOARD/DISPLAY	1062.6809.01 SA	1+

095.0026-0693

Kennz. Comp. No.	Benennung Designation	Sachnummer Stock No.	Hersteller Manufacturer	Bezeichnung Designation	enthalten in contained in
JS28	SB KAPPE HGR. 10,5X10,5"6" PUSHBUTTON "6"	SB 0396.0274.00	DEKORSY	R&S.ZCHNG.396.0274	
JS29	SB KAPPE HGR. 10,5X10,5"9" CAP "9"	SB 0396.0300.00	DEKORSY	R&S.ZCHNG.396.0300	
JS30 ..33	SB TASTENKAPPE 6X10,5 HGR CAP 6X10,5 HGR	SB 0396.0122.00	DEKORSY	R&S.ZCHNG.396.0122	
JS37	SB TASTENKAPPE 6X10,5 HGR CAP 6X10,5 HGR	SB 0396.0122.00	DEKORSY	R&S.ZCHNG.396.0122	
L1	LD 100UH 20% 1A 0,6500HM CHOKE	LD 0155.9446.00	SIEMENS	B82111-E-C25	
N1	BO CA3240AE 2XMOSFETOPAMP DUAL MOSFET-INPUT OPAMP	0302.7040.00	RCA	CA3240AE	
P1	VL EINPRESSTIFT L=6,8 PIN	VL 0010.7250.00	AMP	1-928776-5	
R1	RG 182 KOHM+-1%TK100 1206 RESISTOR CHIP	RG 0007.5989.00	ROEDERSTEI	DC2 182KOHM 1%TK100	
R3	RG 1,0 KO +-1%TK100 1206 CHIP RESISTOR	RG 0006.7271.00	ROEDERSTEI	DC2 1,0KOHM 1%TK100	
R4	RG 1,0 KO +-1%TK100 1206 CHIP RESISTOR	RG 0006.7271.00	ROEDERSTEI	DC2 1,0KOHM 1%TK100	
R5 ..7	RG 100,0KOH+-1%TK100 1206 CHIP RESISTOR	RG 0007.1948.00	ROEDERSTEI	DC2 100KOHM 1%TK100	
R8	RG 182 KOHM+-1%TK100 1206 RESISTOR CHIP	RG 0007.5989.00	ROEDERSTEI	DC2 182KOHM 1%TK100	
R9 ..11	RG 100,0KOH+-1%TK100 1206 CHIP RESISTOR	RG 0007.1948.00	ROEDERSTEI	DC2 100KOHM 1%TK100	
R12	RG 681 KOHM+-1%TK100 1206 RESISTOR CHIP	RG 0007.6110.00	ROEDERSTEI	DC2 681KOHM 1%TK100	
R13	RG 100,0KOH+-1%TK100 1206 CHIP RESISTOR	RG 0007.1948.00	ROEDERSTEI	DC2 100KOHM 1%TK100	
R14	RG 47,5KOHM+-1%TK100 1206 RESISTOR CHIP	RG 0007.5950.00	ROEDERSTEI	DC2 47,5KOHM 1%TK100	
R15	RS 0,5W5KOHM+-10%10X10X5 CERMET POTENTIOMETER T	RS 0247.7890.00	SPECTROL	63 M ... TO 10	
R16	RG 5,62KOHM+-1%TK100 1206 CHIP RESISTOR	RG 0007.0735.00	ROEDERSTEI	DC2 5,62KOHM 1%TK100	
R17	RG 22,1KOHM+-1%TK100 1206 RESISTOR CHIP	RG 0007.5872.00	ROEDERSTEI	DC2 22,1KOHM 1%TK100	
R18	RG 10,0KOHM+-1%TK100 1206 RG CHIP RESISTOR	RG 0007.0793.00	ROEDERSTEI	DC2 10,0KOHM 1%TK100	
R20 ..25	RG 1,0 KO +-1%TK100 1206 CHIP RESISTOR	RG 0006.7271.00	ROEDERSTEI	DC2 1,0KOHM 1%TK100	
R26	RG 1,82KOHM+-1%TK100 1206 RESISTOR CHIP	RG 0007.5720.00	ROEDERSTEI	DC2 1,82KOHM 1%TK100	
R27 ..29	RG 10,0KOHM+-1%TK100 1206 RG CHIP RESISTOR	RG 0007.0793.00	ROEDERSTEI	DC2 10,0KOHM 1%TK100	
R30 ..39	RG 1,0 KO +-1%TK100 1206 CHIP RESISTOR	RG 0006.7271.00	ROEDERSTEI	DC2 1,0KOHM 1%TK100	
R40 ..45	RG 56,2KOHM+-1%TK100 1206 CHIP RESISTOR	RG 0007.1883.00	ROEDERSTEI	DC2 56,2KOHM 1%TK100	
S1 ..33	SB TASTER 1XA OHNE KNOPF PUSHBUTTON SWITCH	SB 0238.3850.00	SIEMENS	V42 263-D32-M2	
S37	SB TASTER 1XA OHNE KNOPF PUSHBUTTON SWITCH	SB 0238.3850.00	SIEMENS	V42 263-D32-M2	
V1	AK BC850B N 45V 200MA TRANSISTOR	AK 0007.7969.00	VALVO	BC850B	
V2 ..11	AF HLMP1790 LED3 GN569N LED	0007.5250.00	QUALITY	HLMP-1790.7418D	
X1 X10	DY KABEL W1 FP STIFTELEISTE 36P.R2,54 PIN CONNECTOR 2-POLIG	1062.6873.00 FP 0242.3600.00	BINDER	742-11-0179-00-36	

Für diese Unterlage behalten wir uns alle Rechte vor.

095.0026-0693

MENPS	413 3PUA	Äi	Datum Date	Schaltteilliste für Parts list for	Sachnummer Stock No.	Blatt-Nr. Page
	ROHDE & SCHWARZ	06	16.09.97	ED TASTATUR/ANZEIGE KEYBOARD/DISPLAY	1062.6809.01 SA	2-

14m+														
Part	Side	X	Y	Sqr Pg	Part	Side	X	Y	Sqr Pg	Part	Side	X	Y	Sqr Pg
B1	B	290	52	1D 3	H3	A	169	88	11D 2	R45	A	22	48	2C 2
B2	B	284	57	2D 3	H4	A	294	88	11D 2	S1	B	19	9	6F 3
C1	A	112	74	2A 2	H10	B	31	81	5E 2	S2	B	19	24	6E 3
C2	A	107	78	2A 2	H20	B	180	81	8E 2	S3	B	19	55	6E 3
C3	A	214	76	4A 2	L1	B	33	48	2B 2	S4	B	50	9	6E 3
C4	A	222	78	4A 2	N1-A	B	150	100	5B 2	S5	B	50	24	6D 3
C5	A	166	105	5A 2	N1-B				7A 2	S6	B	34	55	6F 3
C6	A	161	93	5B 2	N1-C				8A 2	S7	B	91	9	6E 3
C7	A	299	54	1D 3	P1	B	155	76	5B 2	S8	B	91	24	6E 3
C8	A	282	64	2D 3	R1	A	112	88	4F 2	S9	B	91	39	6E 3
C9	A	231	64	5C 3	R3	A	18	51	2C 2	S10	B	91	55	6D 3
C11	A	14	19	2B 2	R4	A	18	48	2C 2	S11	B	109	13	7F 3
C12	A	30	48	2B 2	R5	A	110	74	2A 2	S12	B	109	34	7E 3
C13	A	130	36	2A 3	R6	A	105	78	2A 2	S13	B	109	55	7E 3
C14	A	130	22	3A 3	R7	A	102	74	3A 2	S14	B	138	9	7E 3
C15	A	248	65	4A 3	R8	A	224	84	8F 2	S15	B	138	24	7D 3
C16	A	262	68	4A 3	R9	A	219	74	4A 2	S16	B	138	39	7F 3
C17	A	243	56	5A 3	R10	A	217	74	4A 2	S17	B	138	55	7E 3
C18	A	237	54	6A 3	R11	A	214	78	4A 2	S18	B	168	13	7E 3
C20	A	92	76	1A 2	R12	A	149	104	5A 2	S19	B	168	29	7E 3
C21	A	207	74	3A 2	R13	A	153	98	5A 2	S20	B	168	44	7D 3
D1-A	A	105	82	4F 2	R14	A	165	98	5B 2	S21	B	168	59	8F 3
D1-B				2A 2	R15	B	157	93	5B 2	S22	B	184	13	8E 3
D1-C				2A 2	R16	A	161	90	5A 2	S23	B	184	29	8E 3
D2-A	A	217	82	7F 2	R17	A	164	101	6A 2	S24	B	184	44	8E 3
D2-B				3A 2	R18	A	158	110	7A 2	S25	B	184	59	8D 3
D2-C				4A 2	R20	A	295	51	2D 3	S26	B	199	13	8F 3
D3-A	A	121	36	9D 3	R21	A	276	68	2D 3	S27	B	199	29	8E 3
D3-B				2B 3	R22	A	294	58	2D 3	S28	B	199	44	8E 3
D4-A	A	121	23	9C 3	R23	A	263	59	2C 3	S29	B	199	59	8E 3
D4-B				2B 3	R24	A	246	56	3D 3	S30	B	222	9	8D 3
D5-A	A	272	68	3D 3	R25	A	260	62	3E 3	S31	B	222	24	8F 3
D5-B				3D 3	R26	A	231	57	4C 3	S32	B	222	39	8E 3
D5-C				3C 3	R27	A	243	67	7A 3	S33	B	222	55	8E 3
D5-D				7A 3	R28	A	259	65	7A 3	S37	B	50	55	9E 3
D5-E				3B 3	R29	A	133	33	9E 3	V1	A	162	104	5A 2
D6-A	A	257	63	3D 3	R30	A	18	41	10E 3	V2	B	15	39	10E 3
D6-B				3C 3	R31	A	49	34	10E 3	V3	B	45	32	10E 3
D6-C				4B 3	R32	A	55	20	10E 3	V4	B	45	17	10E 3
D7-A	A	234	57	4C 3	R33	A	90	20	11E 3	V5	B	86	17	11E 3
D7-B				5C 3	R34	A	97	34	11E 3	V6	B	86	32	11E 3
D7-C				7B 3	R35	A	99	49	11E 3	V7	B	86	48	11E 3
D7-D				7A 3	R36	A	90	64	11E 3	V8	B	86	63	11E 3
D7-E				5B 3	R37	A	109	24	11E 3	V9	B	105	22	11E 3
D8-A	A	233	44	4E 3	R38	A	109	45	11E 3	V10	B	105	43	11E 3
D8-B				4D 3	R39	A	109	65	11E 3	V11	B	105	63	11E 3
D8-C				4D 3	R40	A	20	32	2D 2	X1	B	5	15	1F 2
D8-D				4D 3	R41	A	20	35	2D 2	X10	B	255	52	4E 3
D8-E				6B 3	R42	A	29	21	2D 2	X11	B	252	52	4E 3
H1	A	16	98	10D 2	R43	A	29	23	2D 2					
H2	A	146	88	10D 2	R44	A	22	52	2C 2					

ROHDE & SCHWARZ	-I	Datum Date	XY-Liste für XY-list for	Sach-Nummer Stock-Nr	Blatt Page
	02	07.07.93	ED ANZEIGE-TASTATUR DISPLAY-KEYBOARD	1062.6809.01 XY	1-



ROHDE & SCHWARZ

Stromläufe
Bestückungspläne
Circuit diagrams
Components plans
Schémas de circuit
Plans des composants

FÜR DIESE UNTERLAGE
BEHALTEN WIR UNS ALLE RECHTE VOR

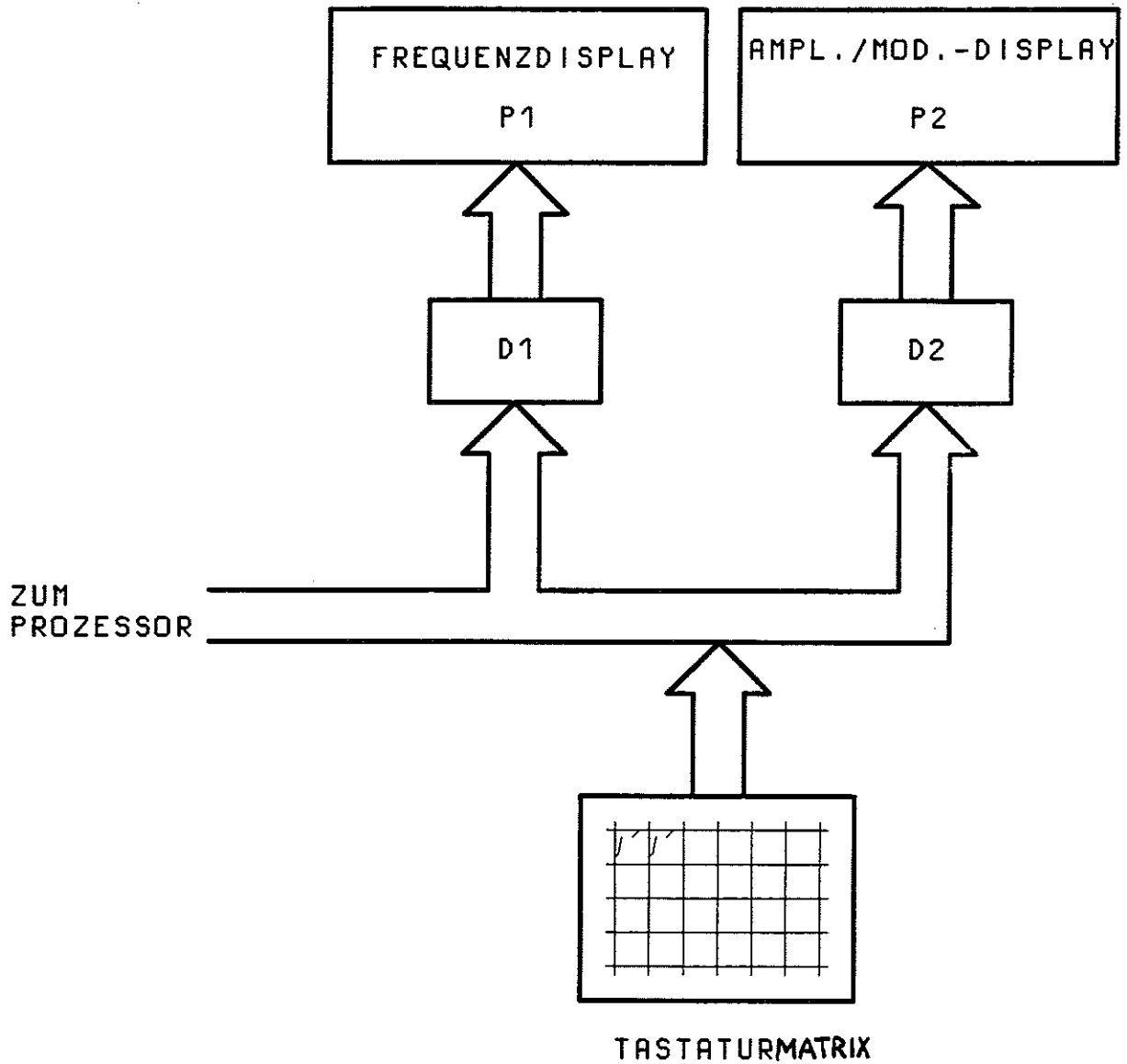

ACHTUNG: EGB!
ELEKTROSTATISCH GEFÄHRDETE
BAUELEMENTE ERFORDERN EINE
BESONDERE HANDHABUNG.
ATTENTION ESD!
ELECTROSTATIC SENSITIVE DEVICES
REQUIRE A SPECIAL HANDLING

STROMLAUF GILT FÜR VAR.02
CIRCUIT DIAGRAM IS VALID FOR MOD.02

01/00				1GPK	TAG	NAME	BENENNUNG	
				BEARB.		SP	ANZEIGE-TASTATUR DISPLAY-KEYBOARD	
				GEPR.		SP		
				NORM				
				PLOTT	18.05.93			
				ROHDE&SCHWARZ			ZEICHN.-NR.	BLATT-NR.
								1062.6809.01S
REND. IND.	RENDERUNGS- MITTEILUNG	DATUM	NAME	ZU GERÄT	1062.55	REG.I.V.	1062.5502	ERSTE Z.
1				2		3		4

ZEICHN.-NR.



ACHTUNG: EGB!
 ELEKTROSTATISCH GEFÄHRDETE
 BAUELEMENTE ERFORDERN EINE
 BESONDERE HANDHABUNG.
ATTENTION ESD!
 ELECTROSTATIC SENSITIVE DEVICES
 REQUIRE A SPECIAL HANDLING

STROMLAUF GILT FUER VAR.01/02

CIRCUIT DIAGRAM IS VALID FOR MOD.01/02

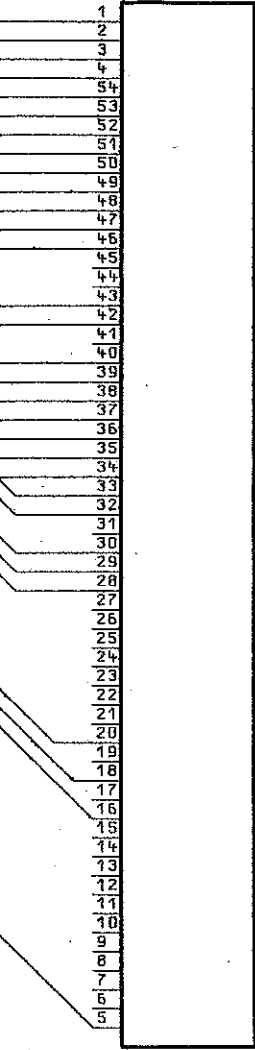

H20

LCD10X 7SEG8

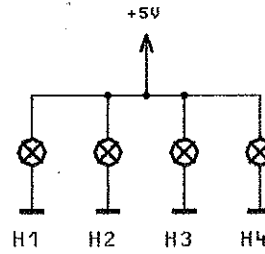

→ S03

01/			SP	1GPK	TAG	NAME	BENENNUNG		
				BEARB.		SP	ANZEIGE-TASTATUR DISPLAY-KEYBOARD		
				GEPR.		SP			
				NORM					
				PLOTT	08.04.94				
/				ROHDE & SCHWARZ		ZEICHN.-NR.		BLATT-NR.	
REND. IND.	RENDERUNGS- MITTEILUNG	DATUM	NAME	ZU GERÄT SMY		REG.I.V.	1062.5502	ERSTE Z.	1062.5502
							1062.6809.01S		2+
									V. BL.

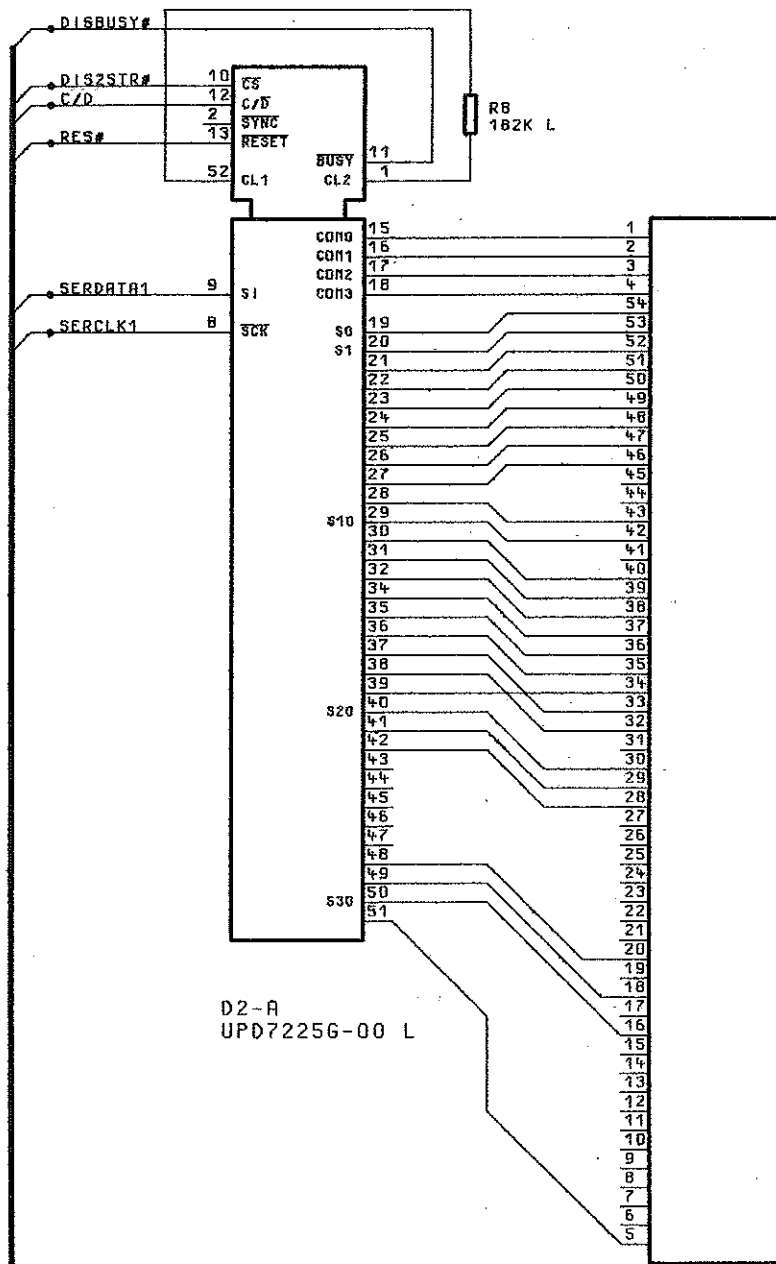



EGM

+5V

R17
22K1 L

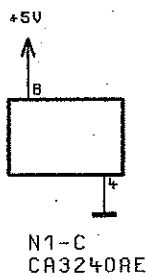
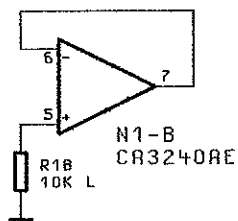
C850B-L



D1/			SP	1GPK	T
				BEARB.	
				GEPR.	
				NDRN	
				PLOTT	08.1
REND. IND.	RENDERUNG- MITTEILUNG	DATUM	NONE	 ZU GERÄT	

6

7

8

9

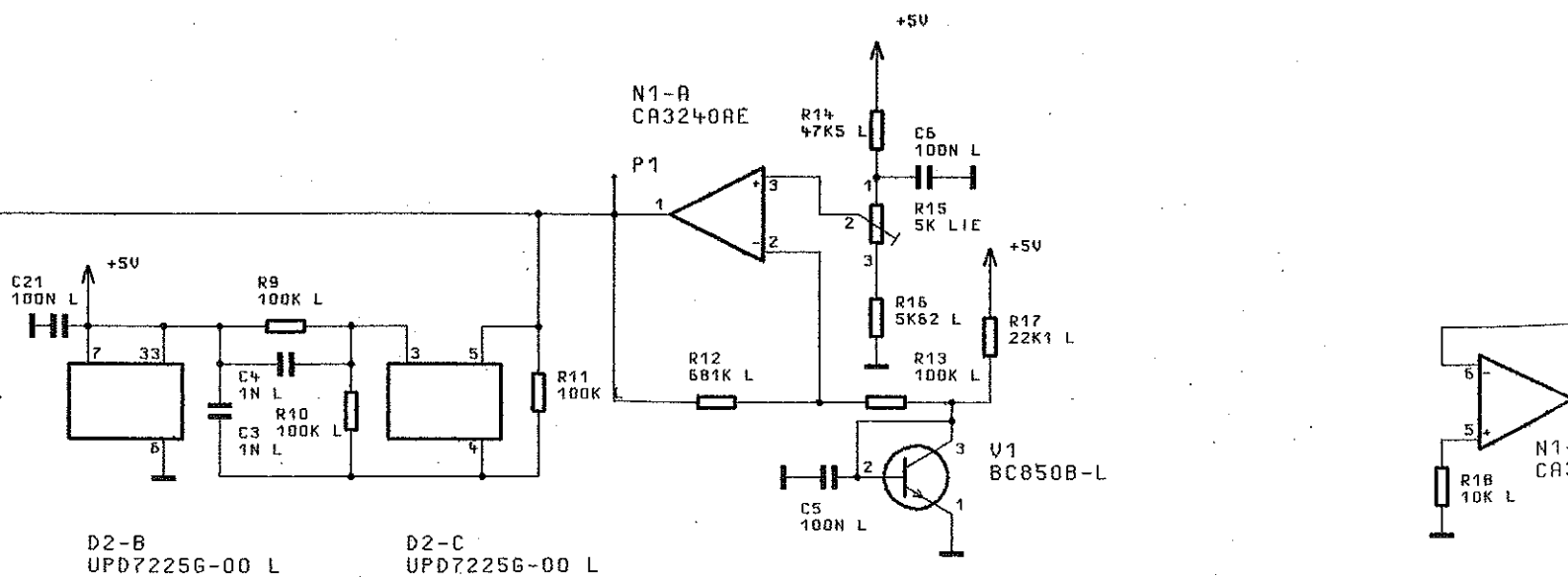
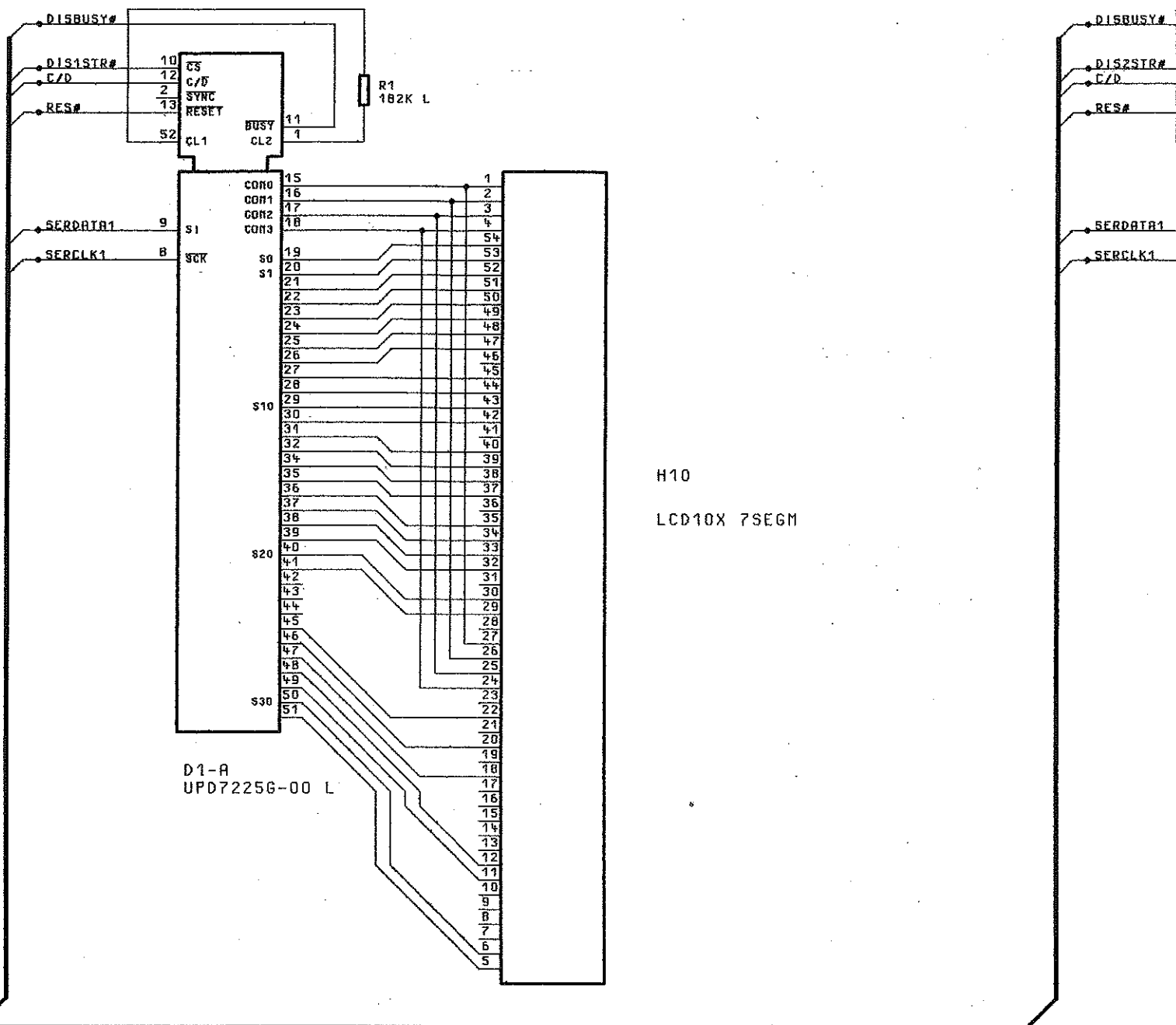

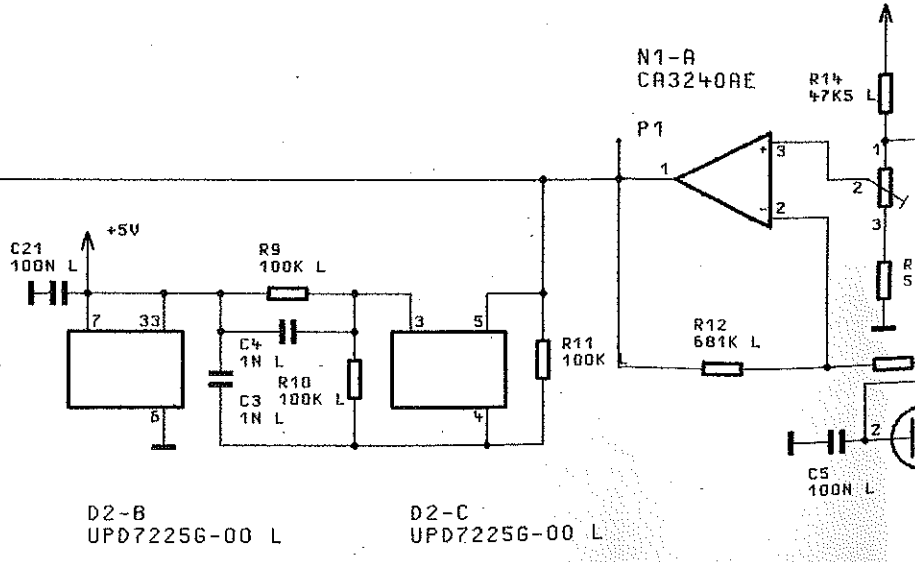
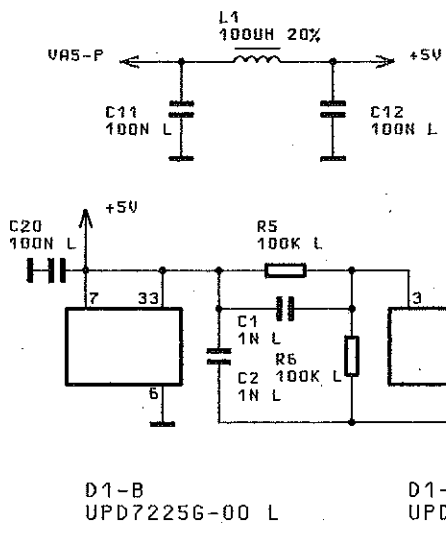
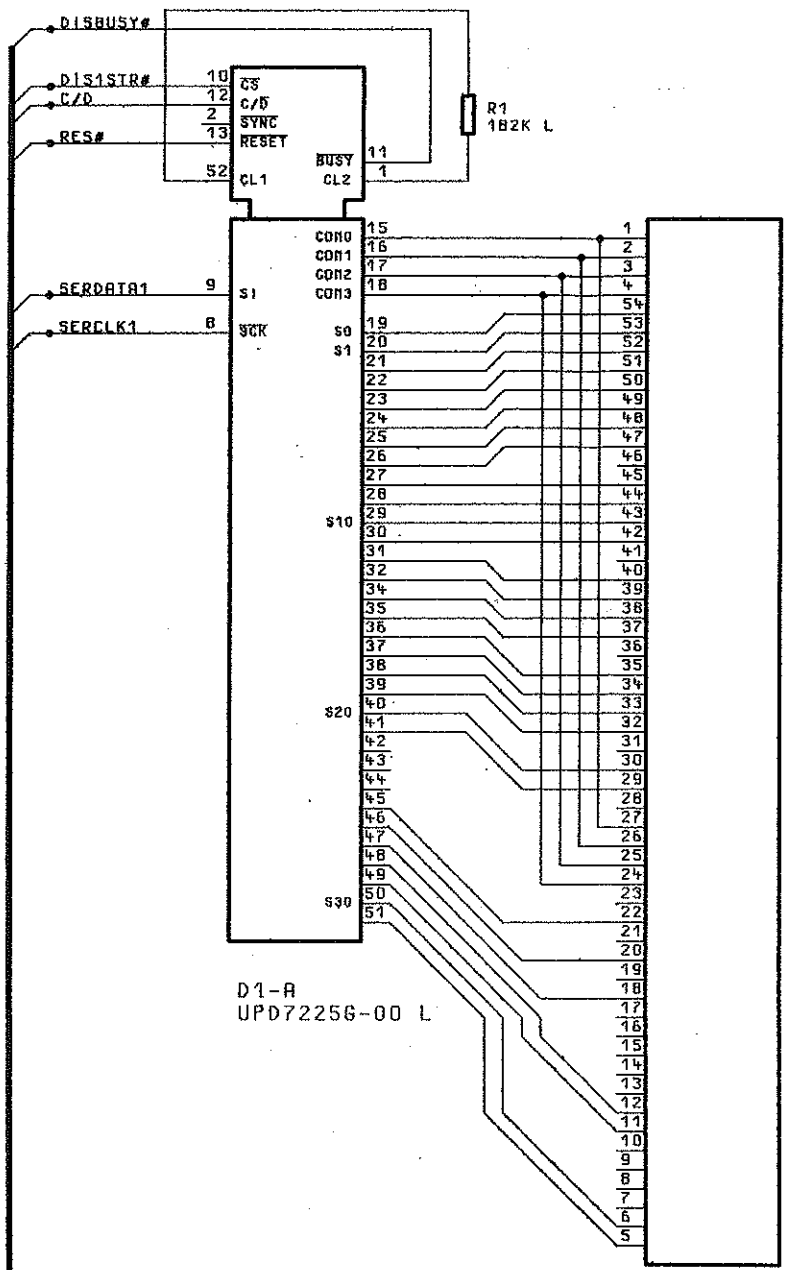
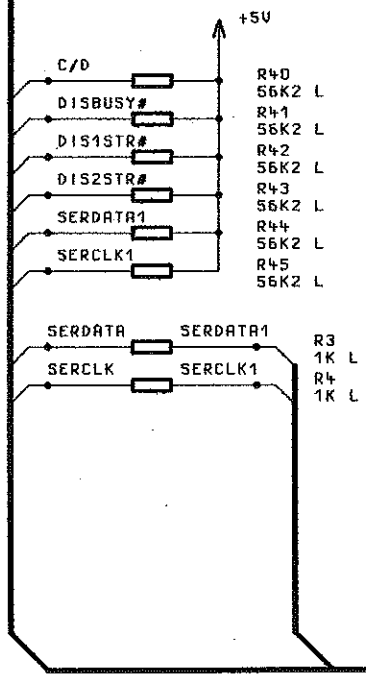
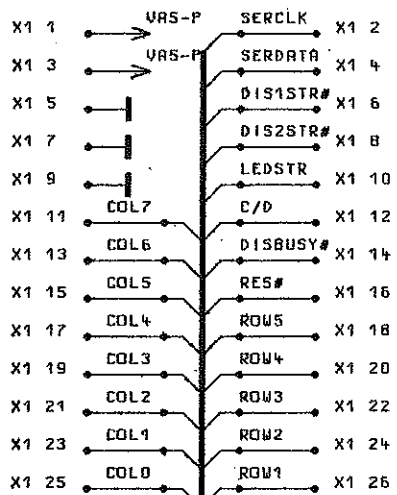

FÜR DIESE UNTERLAGE
BEHALTEN WIR UNS ALLE RECHTE VOR

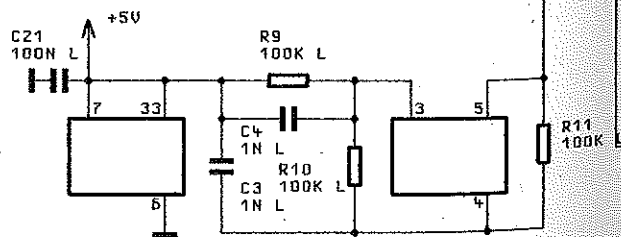
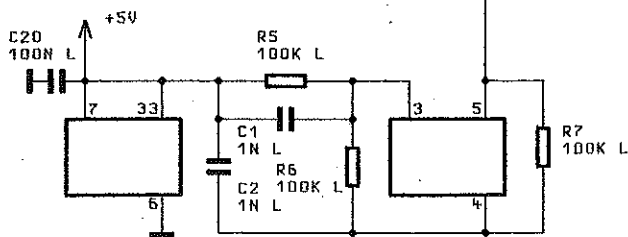
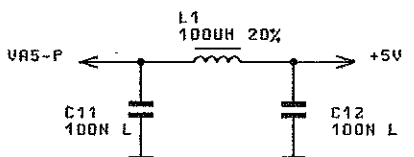
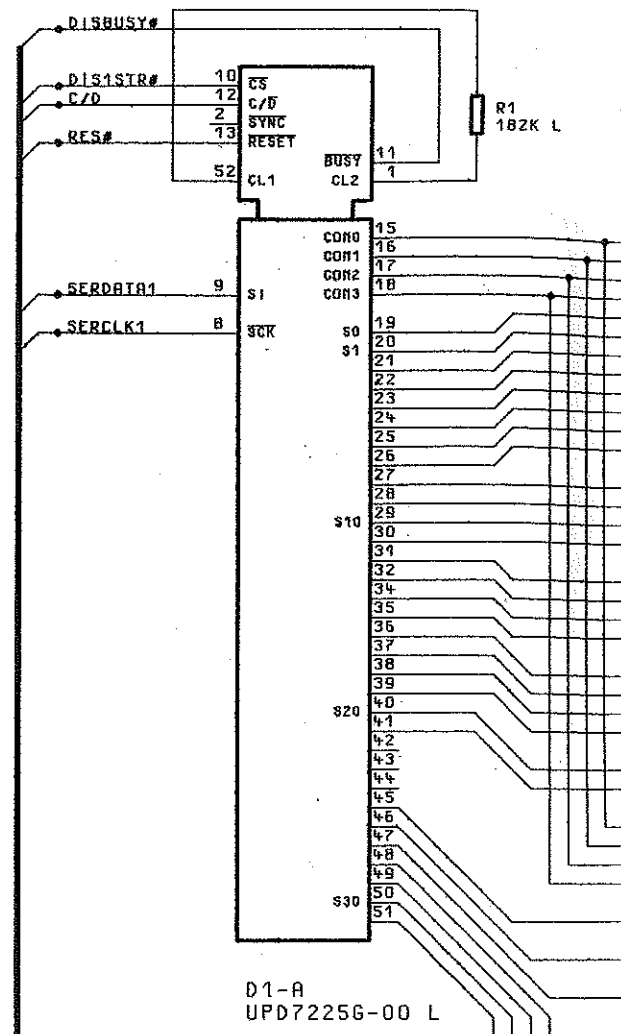
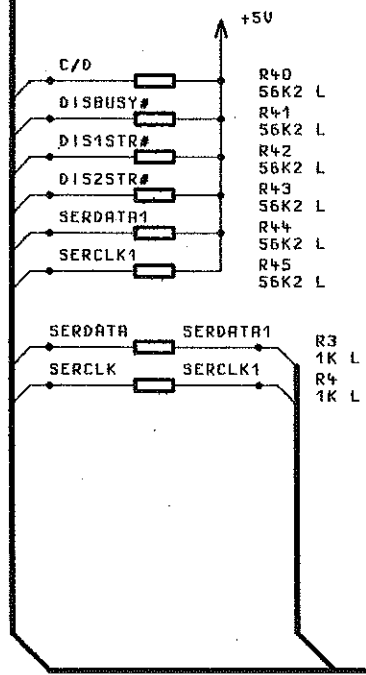
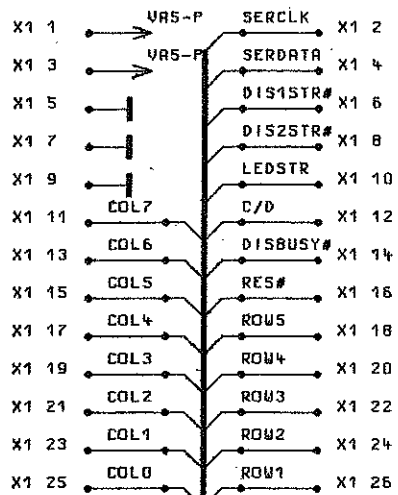

D1-B
UPD7225G-00 L

D1-C
UPD7225G-00 L

D2-B
UPD7225G-00 L

D2-C
UPD7225G-00 L

ZEICHN.-NR.

F
E
D
C
B
A

1 2 3 4

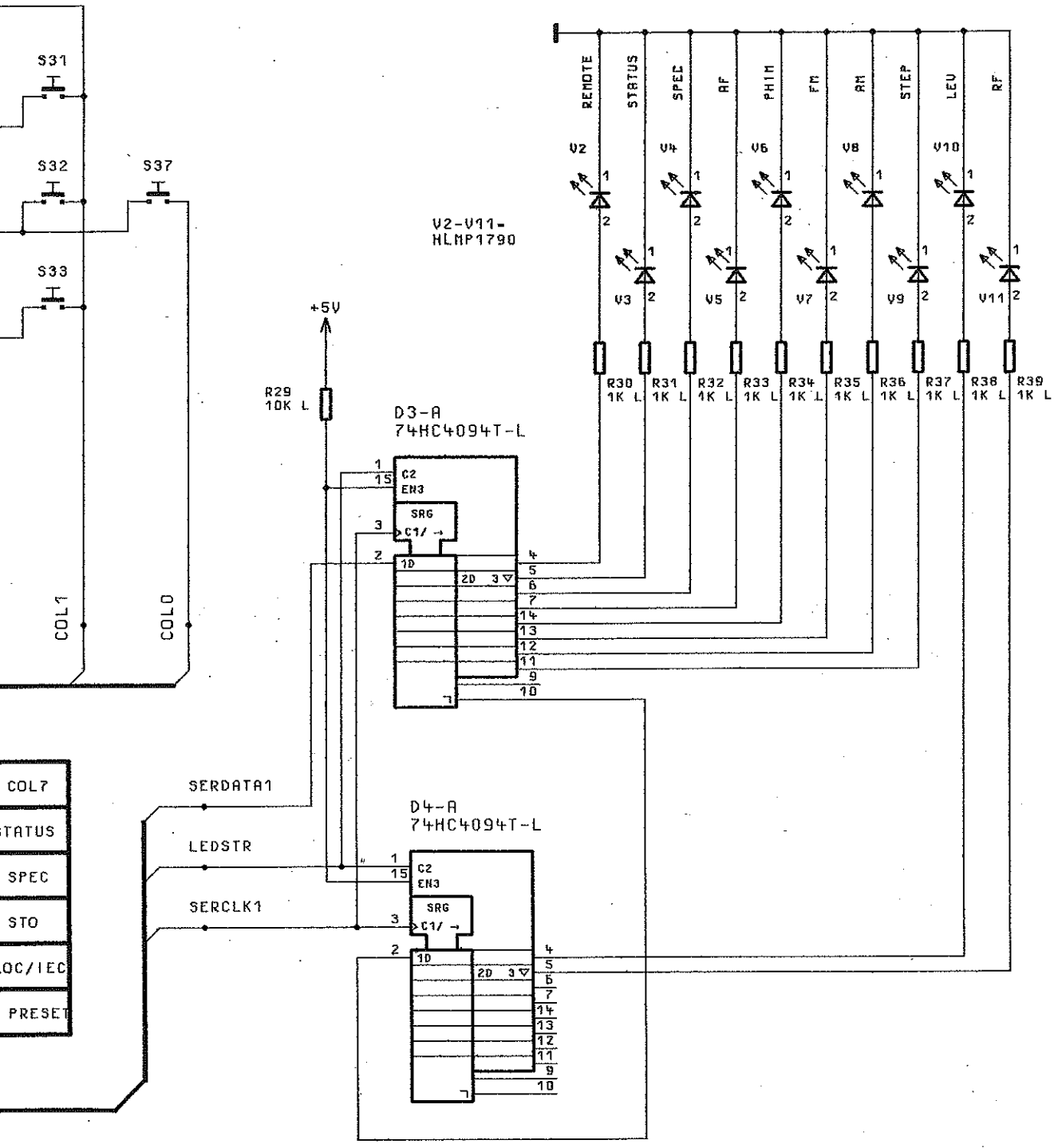

STROMLAUF GILT FUER VAR.02
CIRCUIT DIAGRAM IS VALID FOR MOD.02



ACHTUNG: EGB!
ELEKTROSTATISCH GEFÄHRDETE
BAUELEMENTE ERFORDERN EINE
BESONDERE HANDHABUNG.
ATTENTION ESD!
ELECTROSTATIC SENSITIVE DEVICES
REQUIRE A SPECIAL HANDLING

01/			SP	1GPK	TAG	NAME	BENENNUNG
				BEARB.		SP	ANZEIGE-TASTATUR DISPLAY-KEYBOARD
				GEPR.		SP	
				NORM			
				PLOTT	08.04.94		
							ZEICHN.-NR.
				ROHDE & SCHWARZ			1062.6809.015
REND. IND.	RENDERUNGS- MITTEILUNG	DATUM	NAME	ZU GERÄT	SMY	REG. I.V.	1062.5502
						ERSTE Z.	1062.5502
	9			10		11	12
							BLATT-NR. 3- U. BL.

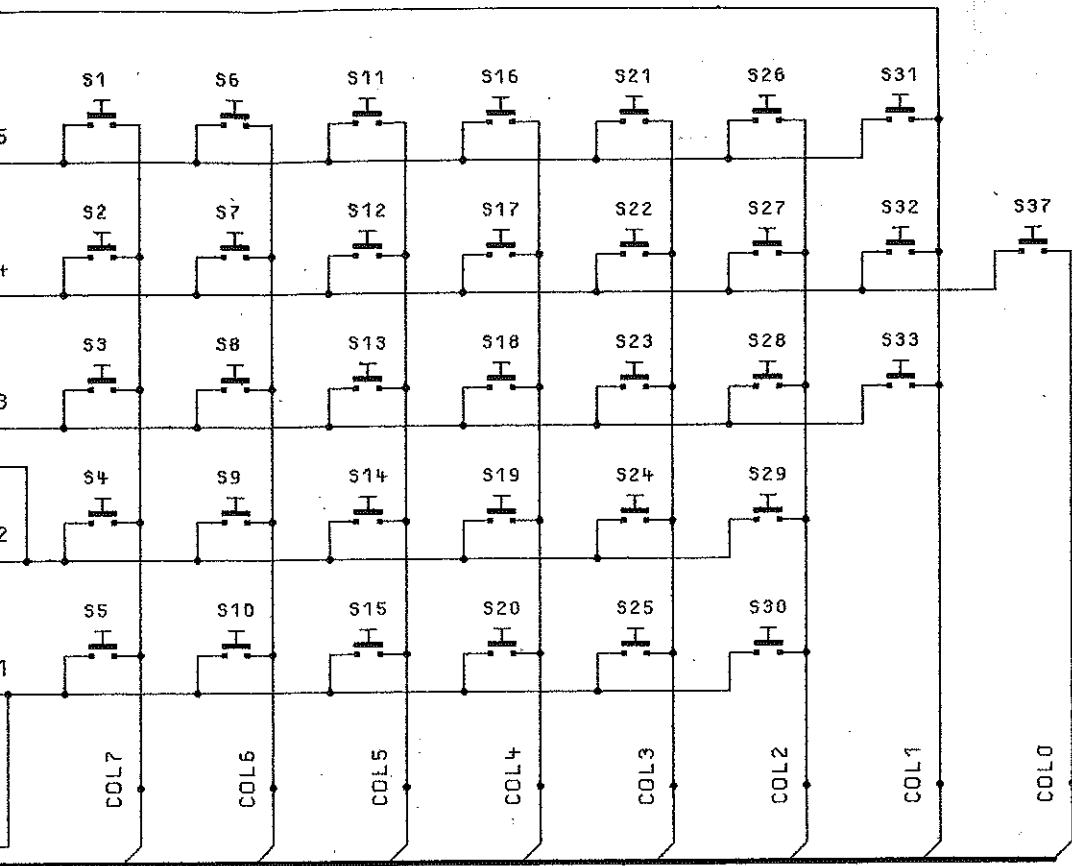

	COL0	COL1	COL2	COL3	COL4	COL5	COL6	COL7
ROW1	NC	(DOWN)	HZ	8	4	EXT DC	AM	STATUS
ROW2	NC	(UP)	9	5	1	OFF	FM	SPEC
ROW3	NC	GHZ	6	2	0	RF	PHI M	STO
ROW4	SEQ	MHZ	3		INT/ON	LEV	AF	LOC/IEC
ROW5	NC	KHZ	-	7	EXT AC	STEP	RCL	PRESET

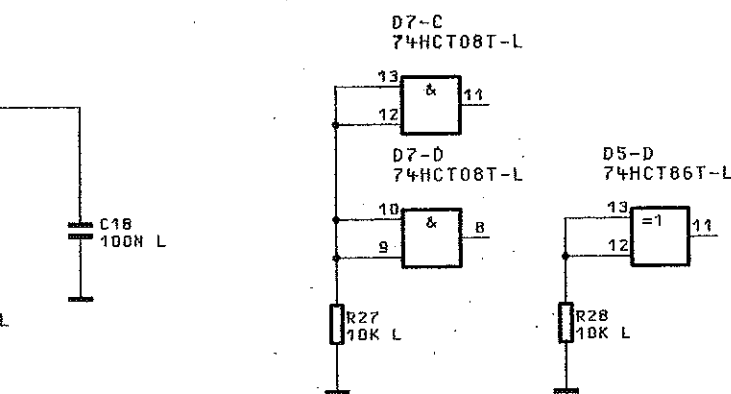
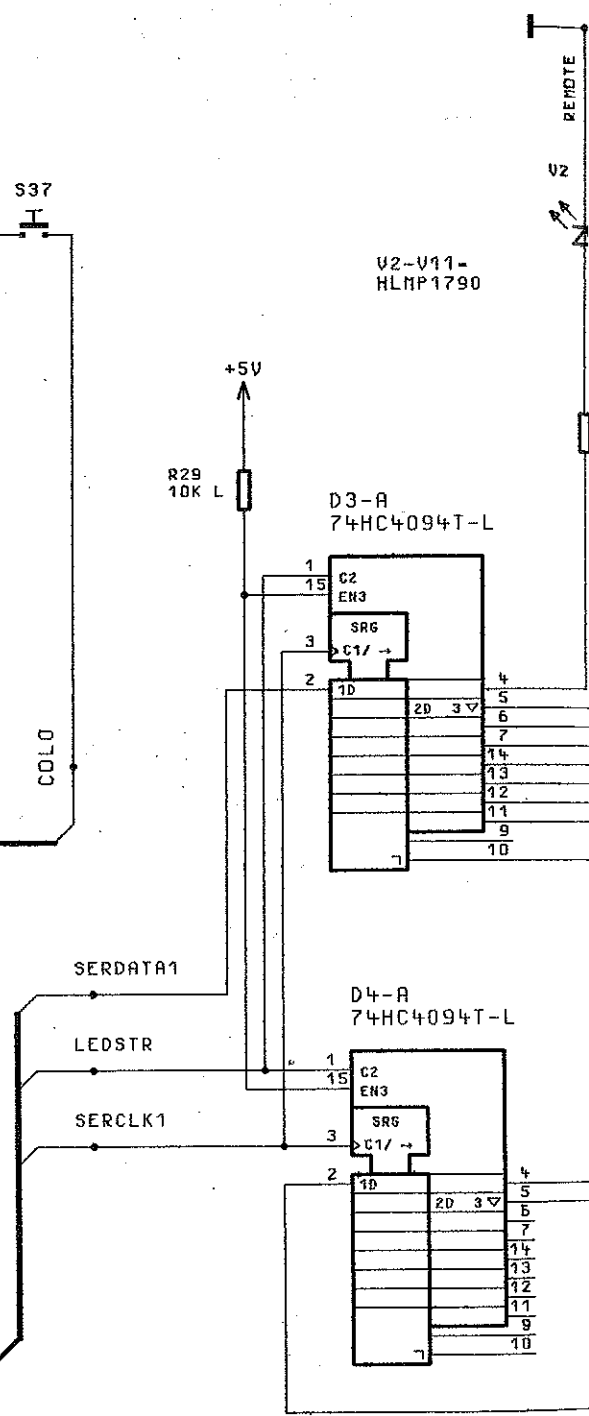

STROMLAUF GILT FUER VA
CIRCUIT DIAGRAM IS VALID FOR MOD

01/			SP	1GPK	TAG
				BEARB.	
				GEPR.	
				NORR	
				PLOTT	08.04.94
				R/S	
				ROHDE&SCH	
REND. IND.	BEREITUNG-NITTEILUNG	DATUM	NAMEN	ZU GERÄT	SMY

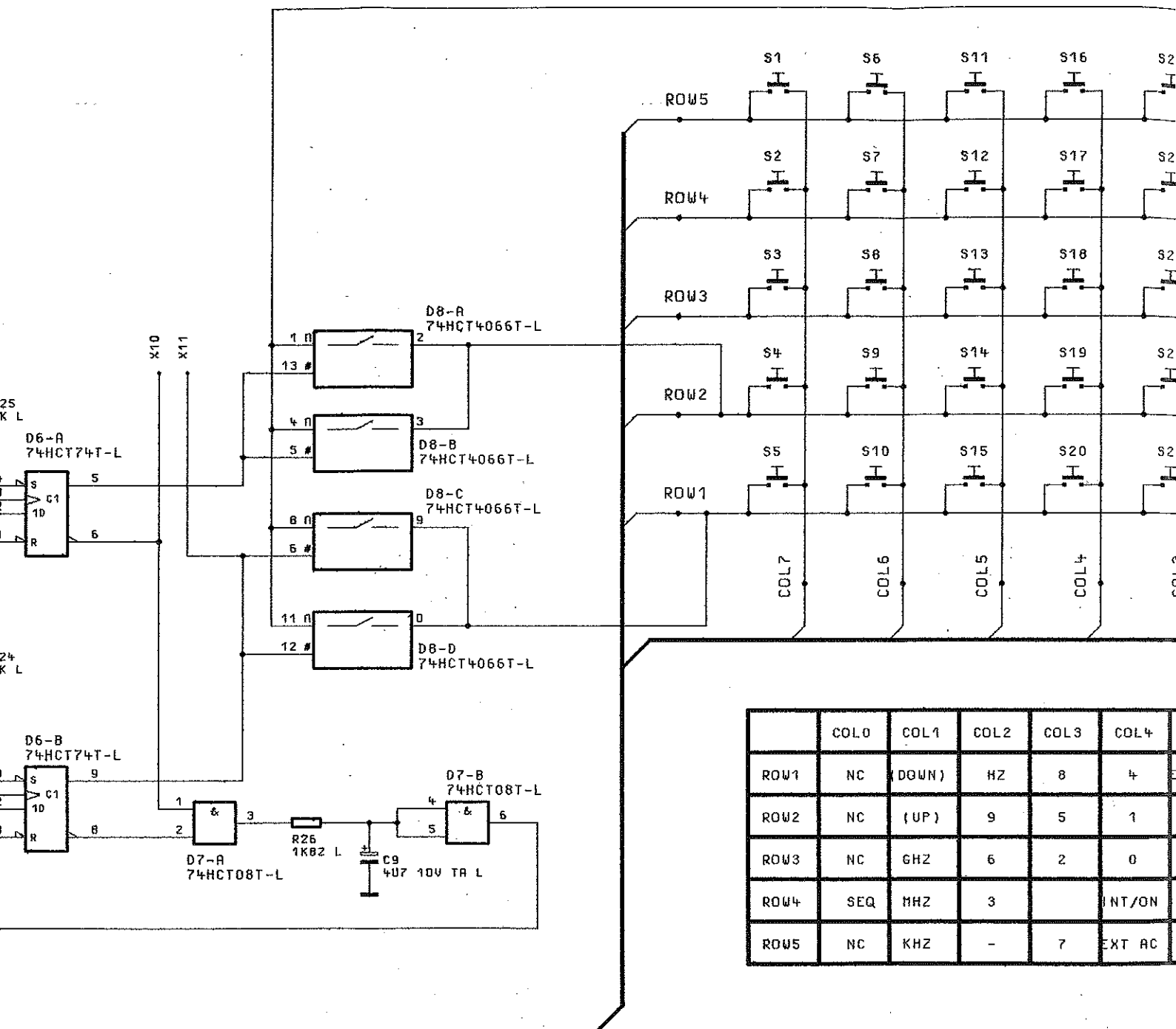

	COL0	COL1	COL2	COL3	COL4
ROW1	NC	(DOWN)	HZ	8	4
ROW2	NC	(UP)	9	5	1
ROW3	NC	GHZ	6	2	0
ROW4	SEQ	MHZ	3		INT/ON
ROW5	NC	KHZ	-	7	EXT AC

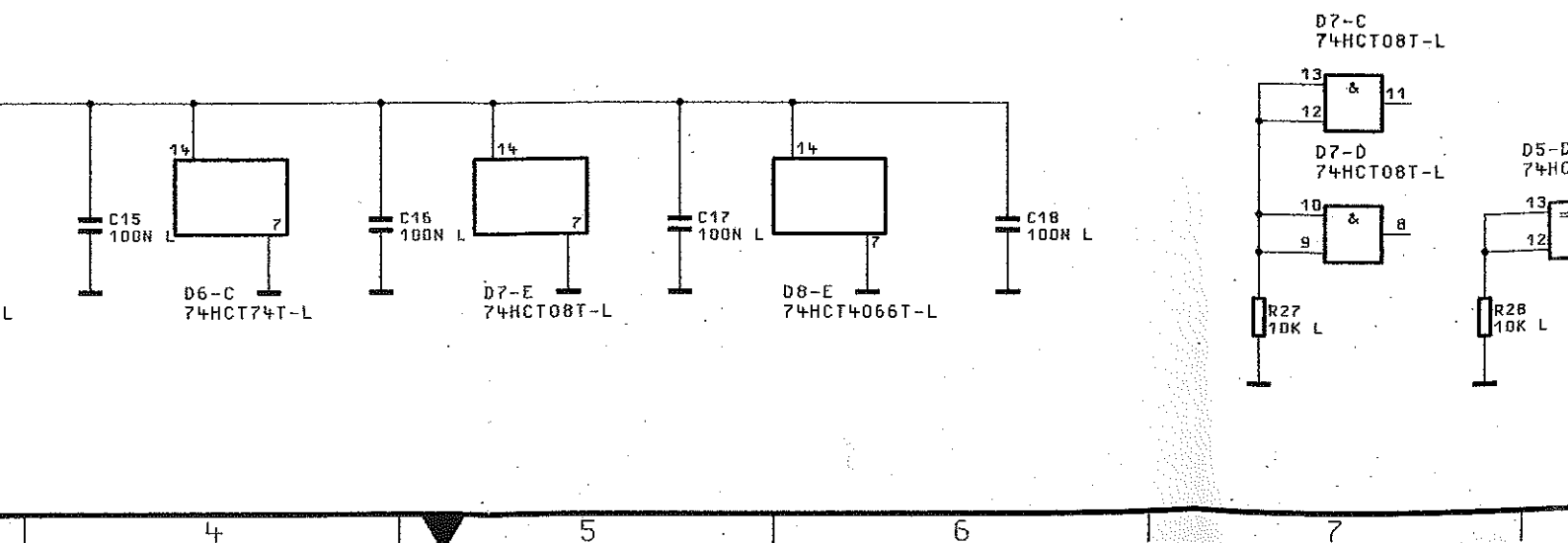

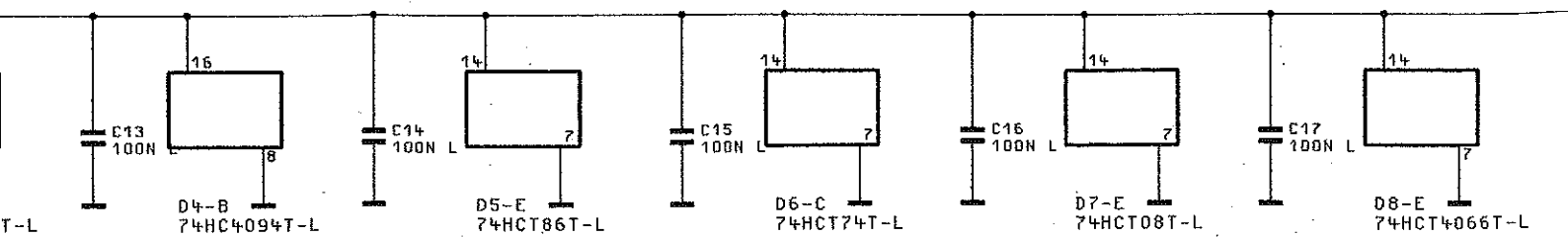
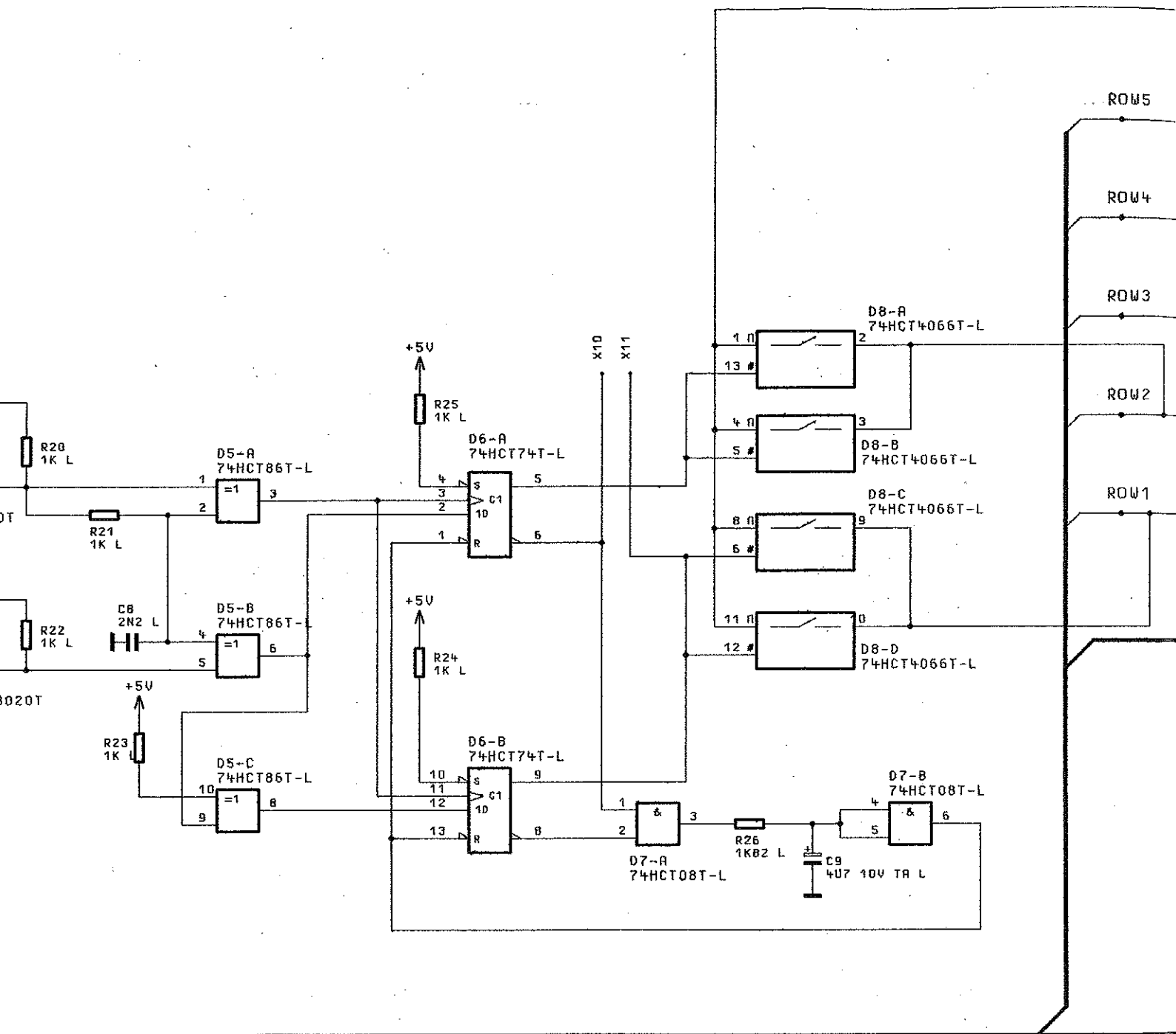

BEHALTEN WIR UNS ALLE RECHTE VOR

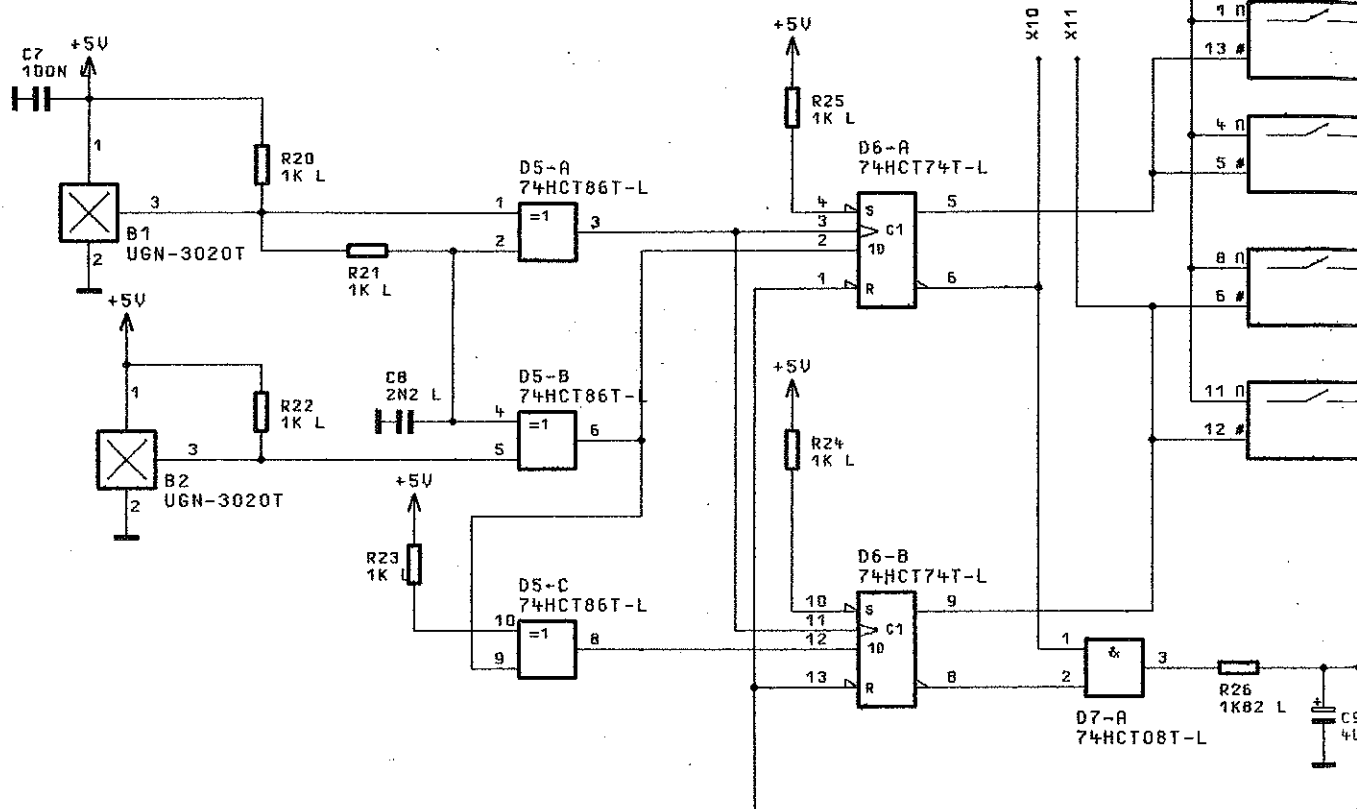

S02

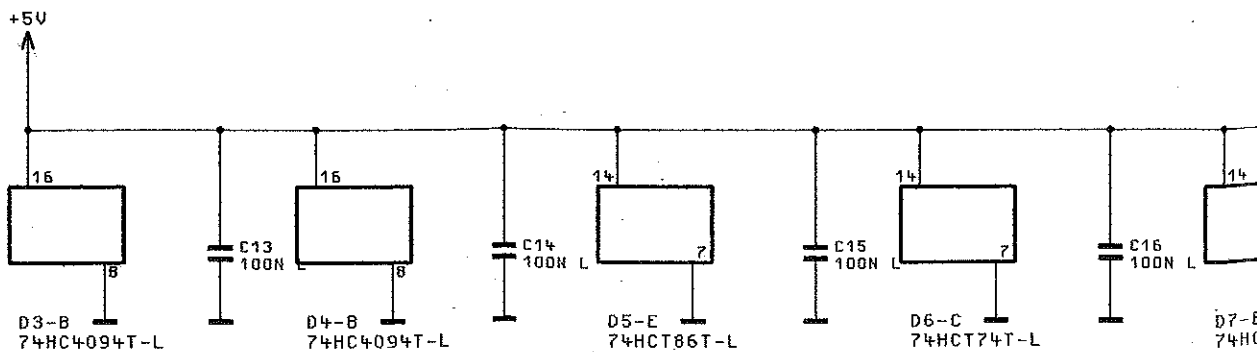

1

2

3

4

N1



H20

P1

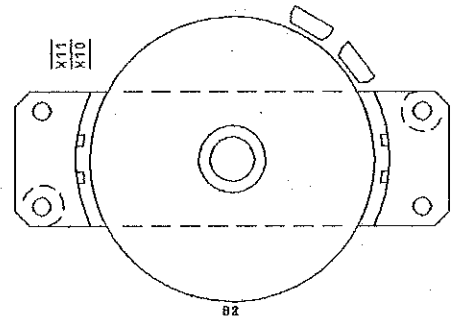
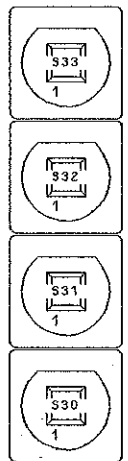
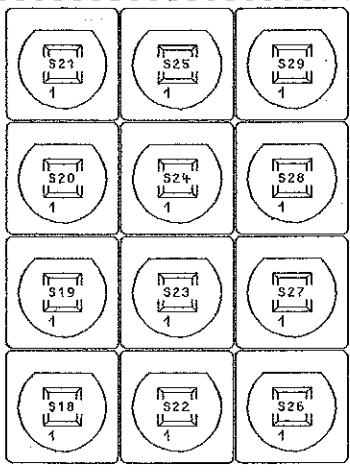

01/			SP	1GPK	TAG	NARE	BENENNUNG		
				BERB.		SP	ANZEIGE-TASTATUR DISPLAY-KEYBOARD	Z	
				GEPR.		SP			
				NDRR					
				PLOTT	08.04.94				
							ZEICHN.-NR.	BLATT-NR.	
							1062.6809.01	ED	1+
REND. IND.	BENDERUNGS- MITTEILUNG	DATUM	NARE			REG. I. V.	1062.5502	ERSTE Z.	1062.5502
7	8	9	10	11					



F1

H10

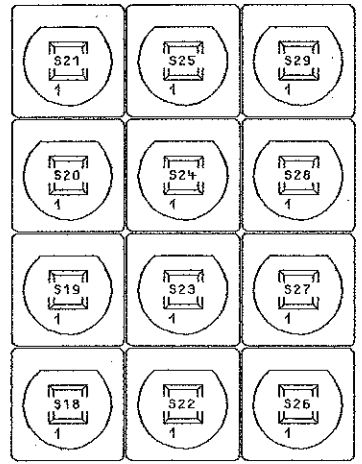
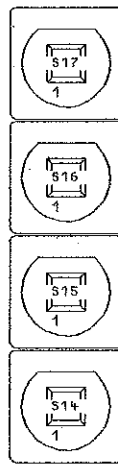
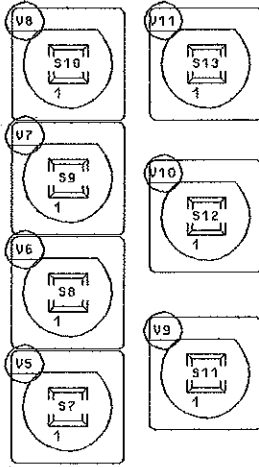
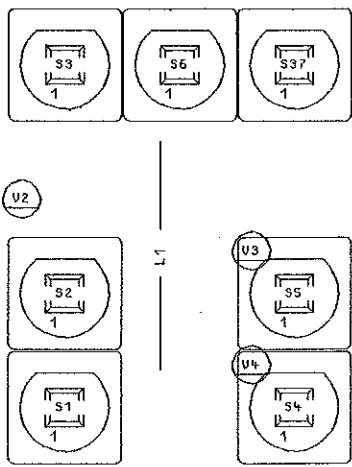

ACHTUNG: ESB!
 ELEKTROSTATISCH DEFENSIBELE
 BAUELEMENTE ERFORDERN EINE
 BESONDERE HANDHABUNG.
ATTENTION ESD!
 ELECTROSTATIC SENSITIVE DEVICES
 REQUIRE A SPECIAL HANDLING

BINDENDE ANGABEN UEBER VARIANTEN,
 TRIMMWERTE, BAUTEILWERTE UND
 NICHT BESTUECKTE BAUTEILE SIEHE SA.

FOR BINDING INFORMATION ON MODELS,
 TRIMMING AND COMPONENTS VALUES AND
 NONFITTED COMPONENTS SEE PARTS LIST.

FÜR DIESE ZEICHNUNG GELTEN DIE ALLGEMEINEN ANWEISUNGEN FÜR DIE HERSTELLUNG VON DRUCKWERKEN.
 FÜR DIESE ZEICHNUNG GELTEN DIE ALLGEMEINEN ANWEISUNGEN FÜR DIE HERSTELLUNG VON DRUCKWERKEN.

DARSTELLUNG SEITE B
 VIEW ON SIDE B



ACHTUNG: ESB!
 ELEKTROSTATISCH GEFÄHRDETE
 BAUELEMENTE ERFORDERN EINE
 BESONDERE HANDHABUNG.
ATTENTION ESD!
 ELECTROSTATIC SENSITIVE DEVICES
 REQUIRE A SPECIAL HANDLING

BINDENDE ANGABEN ÜBER VARIANTEN,
 TRIMMWERTE, BAUTEILWERTE UND
 NICHT BESTÜCKTE BAUTEILE SIEHE SA.
 FOR BINDING INFORMATION ON MODELS,
 TRIMMING AND COMPONENTS VALUES AND
 NONFITTED COMPONENTS SEE PARTS LIST.

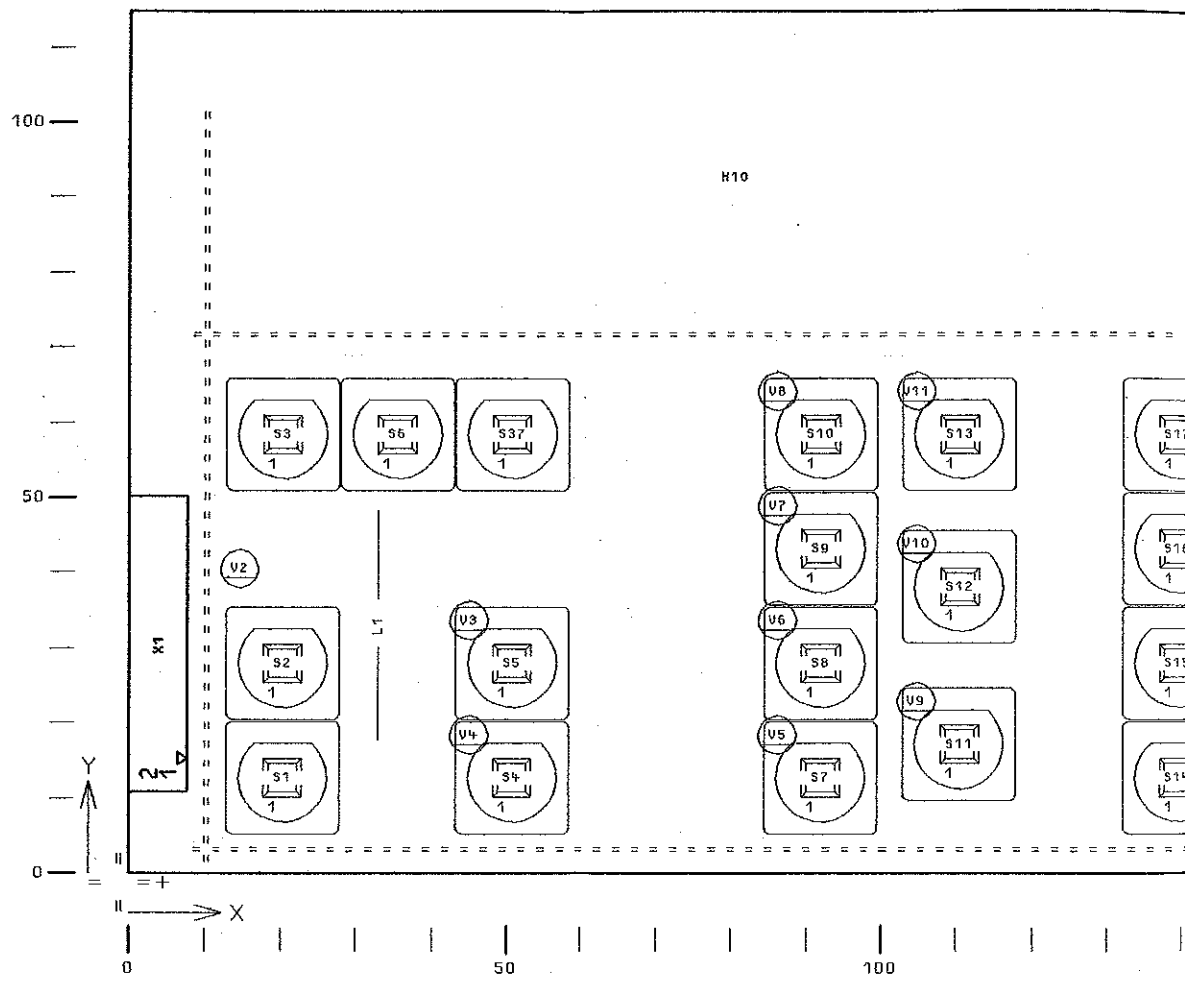

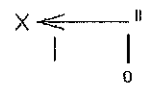
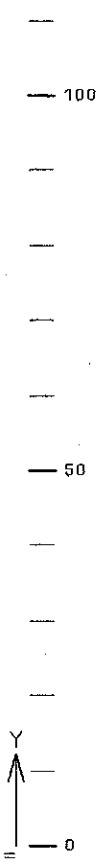
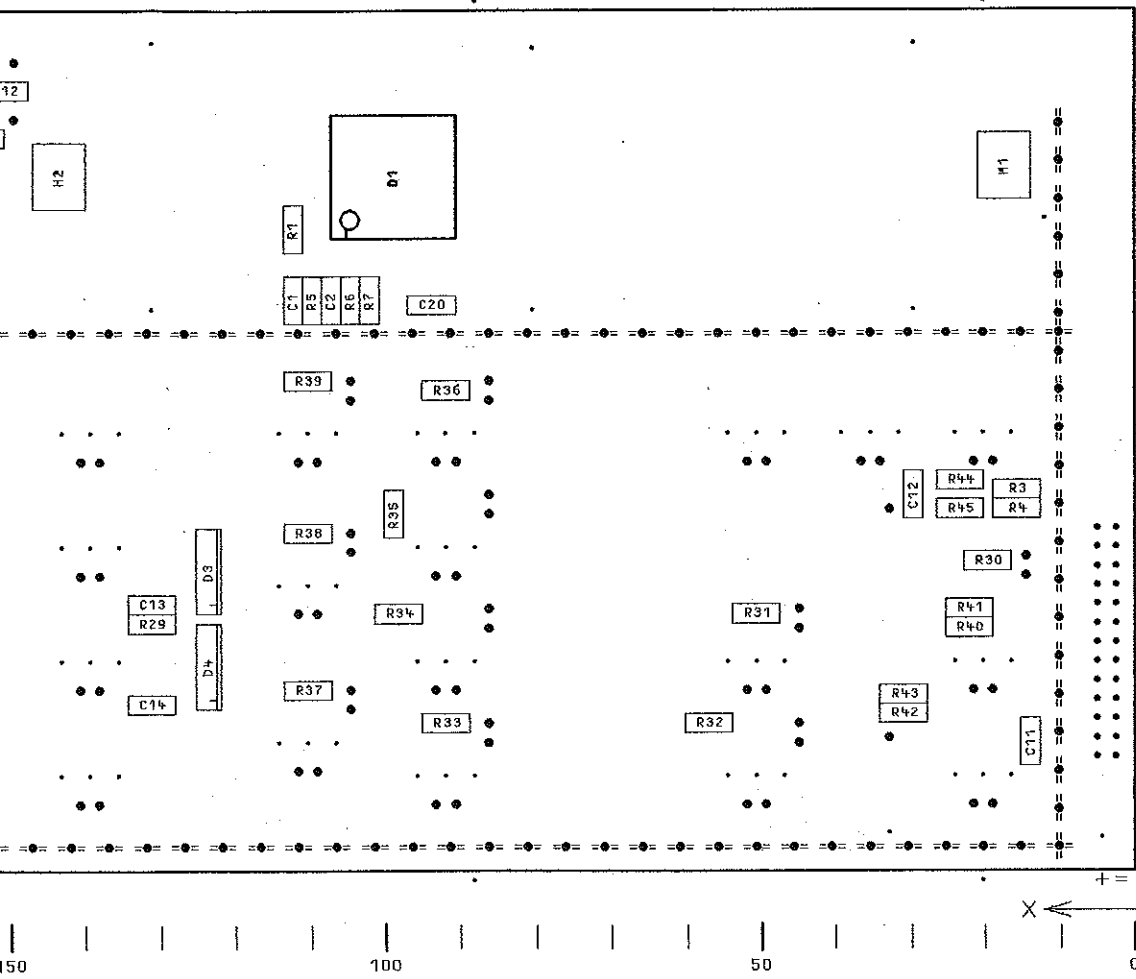

03/			SP	1GPK	TAG	NABE	BENENNUNG	
				BEARB.		SP	ANZEIGE-TASTATUR DISPLAY-KEYBOARD	Z
				GEPR.		SP		
				WORN				
				PLOTT	08.04.94			
				 ROHDE & SCHWARZ		ZEICHN.-NR.		
							1062.6809.01	ED
REND.	ÄNDERUNGS-	DATUM	NABE	ZU SEHRET	SMY	RES. I. V.	1062.5502	KASSE Z. 1062.5502

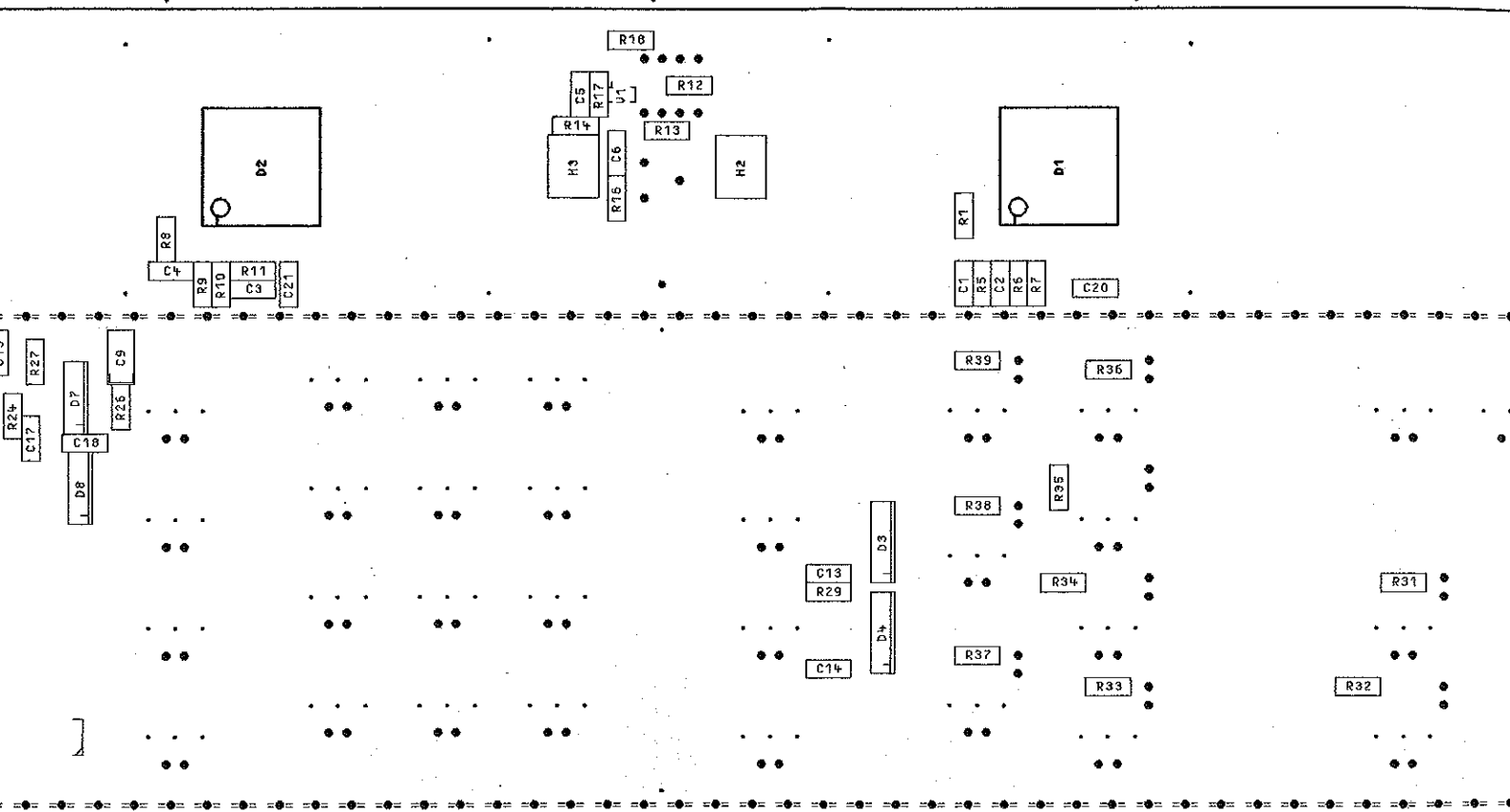

200

150

100

50

BINDENDE ANGABEN UEBER VARIANTEN,
TRIMMWERTE, BAUTEILWERTE UND
NICHT BESTUECKTE BAUTEILE SIEHE SR.

FOR BINDING INFORMATION ON MODELS,
TRIMMING AND COMPONENTS VALUES AND
NONFITTED COMPONENTS SEE PARTS LIST.

B1/			SP	1GP
				DCRR
				GEPR.
				ADRA
				PLOT1
				5
				RO
REND. THO.	RENDERUNGS- MITTELUNG	DATUM	NAMEN	ZU GER

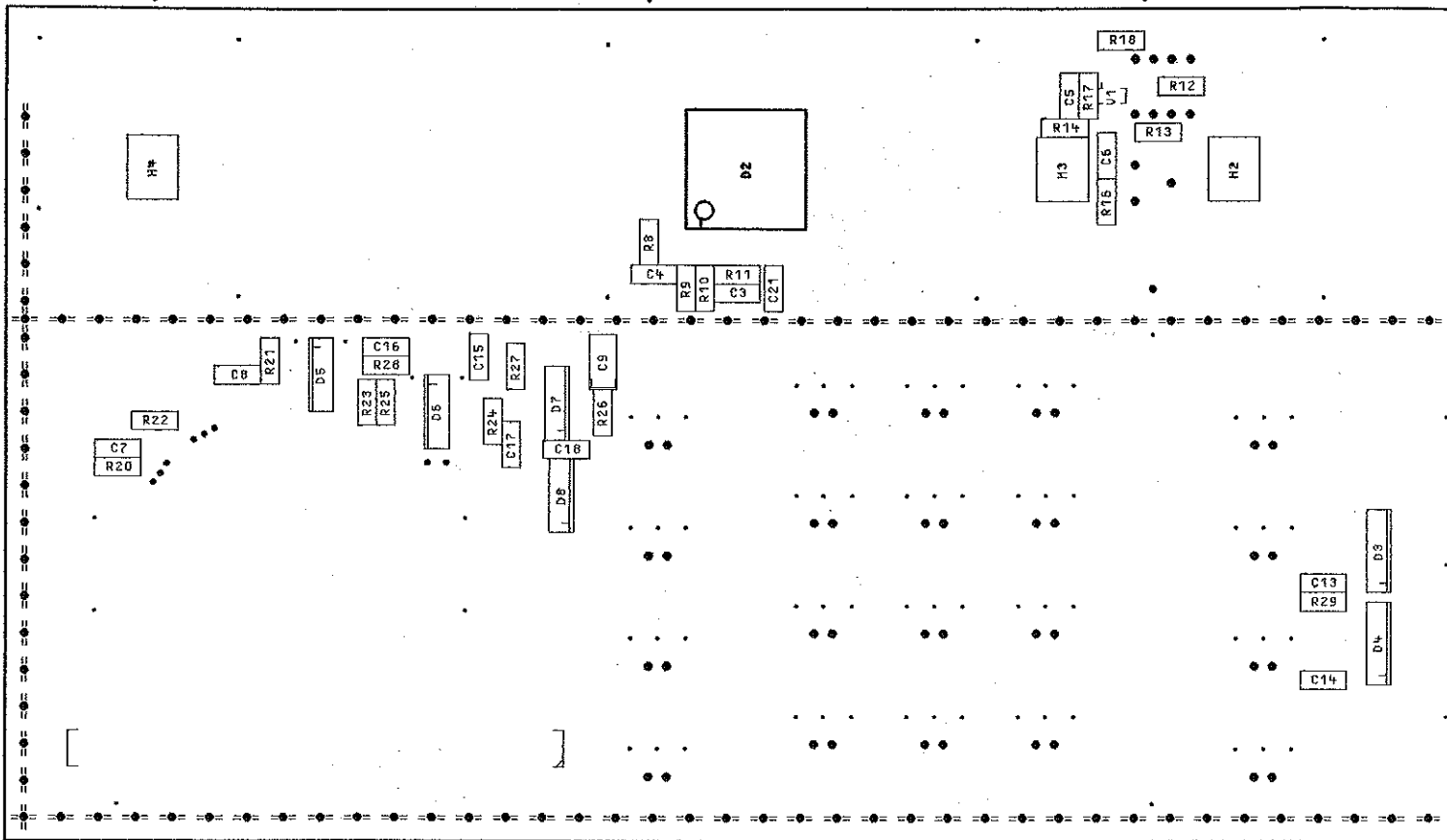

300 250 200 150

LUNG SEITE A
SIDE A



ACHTUNG: ESB!
ELEKTROSTATISCH GEFÄHRDETE
BAUELEMENTE ERFORDERN EINE
BESONDERE HANDHABUNG.
ATTENTION ESD!
ELECTROSTATIC SENSITIVE DEVICES
REQUIRE A SPECIAL HANDLING

BINDENDE ANGABEN UEBER VARIANTEN,
TRIMMWERTE, BAUTEILWERTE UND
NICHT BESTUECKTE BAUTEILE SIEHE SA.

FOR BINDING INFORMATION ON MODELS,
TRIMMING AND COMPONENTS VALUES AND
NOWFITTED COMPONENTS SEE PARTS LIST.

FÜR DIESE ZEICHNUNG BEHALTEN SICH UNS ALLE RECHTE VOR.
 DIESE ZEICHNUNG IST EIN RECHNERDRUCK, ÄNDERUNGEN KÖNNEN NUR DURCH ÄNDEREN DES DATENSATZES BEFOLGEN

H

G

U

F

E

D

C

B

A

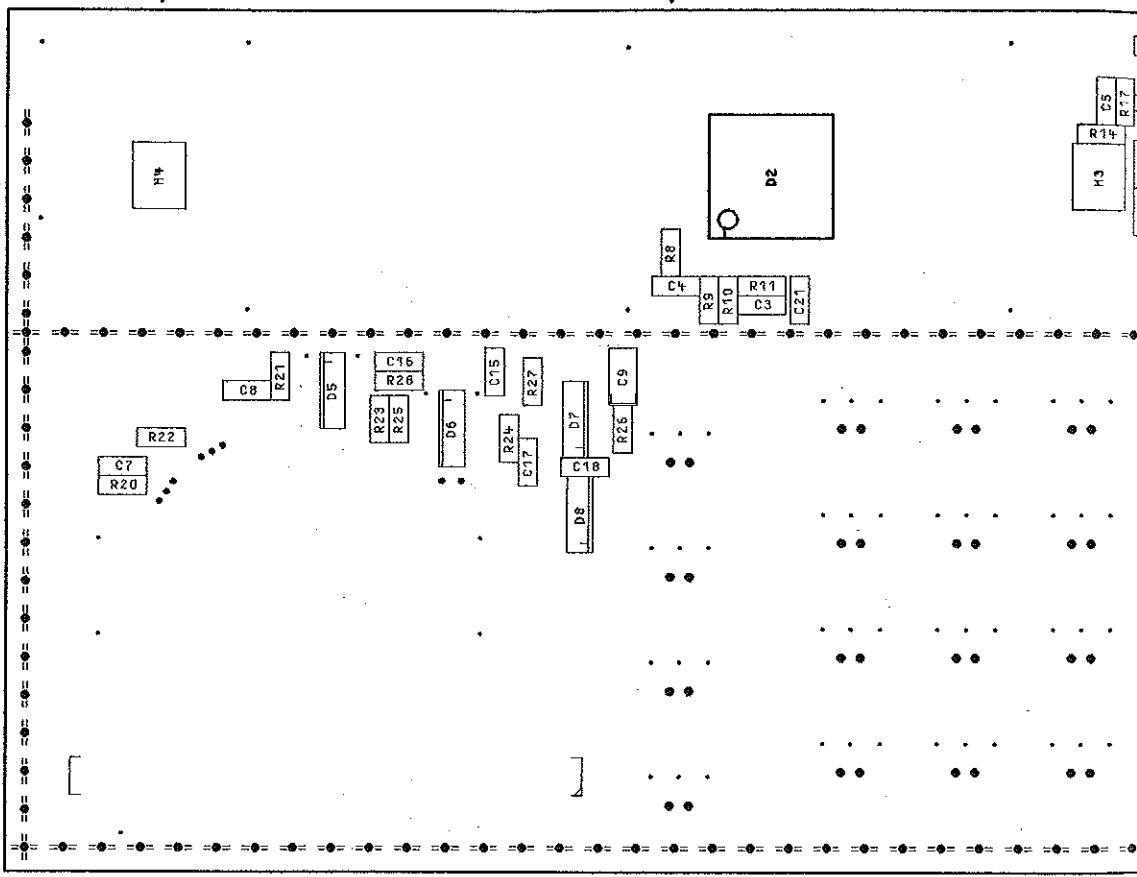

300 250 200

DARSTELLUNG SEITE A
VIEW ON SIDE A



ACHTUNG: EGB!
 ELEKTROSTATISCH GEFÄHRDETE
 BAUELEMENTE ERFORDERN EINE
 BESONDERE HANDLUNG.
ATTENTION ESD!
 ELECTROSTATIC SENSITIVE DEVICES
 REQUIRE A SPECIAL HANDLING

BINDENDE ANGABEN ÜBER VARIANTEN,
 TRIMMWERTE, BAUTEILWERTE UND
 NICHT BESTÜCKTE BAUTEILE SIEHE SA.
 FOR BINDING INFORMATION ON MODELS,
 TRIMMING AND COMPONENTS VALUES AND
 NONFITTED COMPONENTS SEE PARTS LIST.



ROHDE & SCHWARZ

SERVICEUNTERLAGEN

Baugruppe Synthesizer

1062.6409.01

Inhaltsverzeichnis

7 Prüfen und Instandsetzen der Baugruppe	5
7.1 Funktionsbeschreibung	5
7.1.1 Referenzfrequenzen.....	5
7.1.1.1 Referenz Intern 10 MHz.....	5
7.1.1.2 Referenz Extern 5 oder 10 MHz.....	5
7.1.1.3 640 MHz Oszillator mit PLL.....	5
7.1.2 Synthesizer 65...1040 MHz.....	6
7.1.2.1 Oszillatoren 520..1040 MHz.....	6
7.1.2.2 Ausgangsteiler.....	6
7.1.2.3 Fractional-N-Teiler und PLL.....	6
7.1.3 FM/φM Modulation.....	7
7.1.3.1 Funktionsprinzip.....	7
7.1.3.2 FM/φM-Hubteiler.....	7
7.1.3.3 Sigma-Delta-Wandler und FM-DC Regelung.....	8
7.1.4 Kalibrierroutinen.....	8
7.1.4.1 VCO-Kalibrierung.....	8
7.1.4.2 FM-Kalibrierung.....	8
7.2 Meßgeräte und Hilfsmittel	9
7.3 Fehlersuche	9
7.3.1 Synchronisierfehler.....	9
7.3.2 Fehler bei CW-Betrieb.....	10
7.3.3 Fehler bei FM-/φM-Modulation.....	10
7.3.4 Kalibrierungen.....	11
7.4 Prüfen und Abgleich	12
7.4.1 Datenübertragung und Stromversorgung.....	12
7.4.2 Referenzfrequenzerzeugung.....	12
7.4.2.1 Referenz Intern.....	12
7.4.2.2 Referenz Extern.....	13
7.4.3 640 MHz Referenz.....	13
7.4.3.1 Oszillator 640 MHz und PLL.....	13
7.4.3.2 Ausgangsverstärker 640 MHz.....	14
7.4.4 Ausgangsoszillatoren.....	14
7.4.5 PLL der Ausgangsoszillatoren.....	15
7.4.5.1 Überprüfung der Teiler in der PLL.....	15
7.4.5.2 Überprüfung des Phasendetektors.....	15
7.4.5.3 Überprüfung des Regelfilters.....	17
7.4.5.4 Überprüfen der geschlossenen PLL.....	17
7.4.6 Ausgangsstufe mit Teilern.....	17
7.4.7 Prüfen des Hubteilers.....	18

7.4.8	EXT-Überwachung	19
7.4.9	Sigma-Delta-Wandler mit FM-DC-Regelung	19
7.4.10	FM-Hubeinstellung	19
7.4.10.1	Überprüfung FM-Diagnosedetektor	19
7.4.10.2	Abgleich FM-Hub	20
7.4.10.3	Überprüfung der FM-Kalibrierung	20
7.4.11	Einschwingverhalten der Synthese	20
7.4.12	Endprüfungen Synthese	21
7.4.12.1	Störhub Synthesizer	21
7.4.12.2	Störhub 640 MHz Oszillator	22
7.4.12.3	Nebenwellen Synthesizer	22
7.4.12.4	FM-DC Mittenfrequenzkalibrierung	22
7.4.13	Tabellen und Schnittstellen	22
7.4.13.1	Liste der Diagnosemeßpunkte	22
7.4.13.2	Digitale Schnittstelle	23
7.4.13.3	Arbeitspunkte und Pegel von HF-Verstärkern	25
7.5	Zerlegung und Zusammenbau	26
7.6	Externe Schnittstellen	26

Schaltteilliste
 Koordinatenliste
 Stromlauf
 Bestückungsplan

7.1 Funktionsbeschreibung

Die Baugruppe YSYN enthält einen FM/ϕM modulierbaren Synthesizer von 65...1040 MHz, den Hubteiler für FM/ϕM sowie die Referenzfrequenzerzeugung, bestehend aus einem 10 MHz VTCXO sowie einem 640 MHz Oszillator als LO für den Mischerbereich der Ausgangsstufe.

7.1.1 Referenzfrequenzen

7.1.1.1 Referenz Intern 10 MHz

Als Standardreferenz wird ein 10 MHz VTCXO (N200) verwendet. Ein Emitterfolger mit Pegelwandler (V205 und V210) verstärkt das Ausgangssignal auf TTL-Pegel (Meßpunkt P201). Gleichzeitig wird hier das Signal der Optionsreferenz (Eingang X128, OPT10) eingespeist. In dieser Betriebsart wird der Standardoszillator mit dem Schalttransistor V200 ausgeschaltet und der Zweig für die Optionsreferenz über die Diode V235 durchgeschaltet. Die Teilerstufe (D205-A) erzeugt die 2 MHz Referenzfrequenz für die PLL der Ausgangsoszillatoren und den Sigma-Delta-Wandler sowie die 1 MHz Vergleichsfrequenz für den Phasendetektor der Referenz-PLL (Meßpunkt P202). Das über D200 ausgekoppelte 10 MHz Signal dient als Referenzfrequenz für die PLL des 640 MHz Oszillators. In dieser Betriebsart steht entweder die Standardreferenz oder, falls bestückt, die Optionsreferenz am Ausgang X127 (EXTREF) zur Verfügung. Die genaue Frequenzeinstellung geschieht mit einem 12-Bit-D/A-Wandler (D220), dem eine 10 Volt Referenzspannung (+10REF) zur Verfügung steht (Abstimmspannung UINT oder OPTTUNE).

7.1.1.2 Referenz Extern 5 oder 10 MHz

In der Betriebsart Referenz Extern können 5 MHz oder 10 MHz mit einer Toleranz von ± 3 ppm an X127 (EXT REF) eingespeist werden. Eine Diodenschaltung (V220) erzeugt dazu ein Oberwellenspektrum, ein Resonanzverstärker (V215) filtert das 10-MHz-Signal aus und der folgende Pegelwandler (V216) verstärkt es auf TTL-Pegel (Meßpunkt P204). Nach Frequenzteilung durch 10 (D205-B) wird es im Phasendetektor D210 mit der heruntergeteilten Frequenz des TCXO's verglichen. Der Standardreferenzoszillator wird hierbei in einer PLL mit einer Bandbreite von 2 Hz auf die externe Referenz synchronisiert. Die Abstimmspannung der PLL kann an P203 (U-PLL-VTCXO) nachgemessen werden. Ist ein optionaler Referenzoszillator (SM-B1) vorhanden, so ist dessen Pegel in der Betriebsart Ext. Referenz abgeschaltet.

Über einen Spannungsfolger (N220-C) wird die Abstimmspannung des Oszillators in beiden Betriebsarten mit dem Fensterkomparator N100 überwacht.

7.1.1.3 640 MHz Oszillator mit PLL

Der 640 MHz Oszillator ist mit einem keramischen Resonator (X300) aufgebaut, der mit einer Kapazitätsdiode (V300) fein abgestimmt wird. Die Transistorstufe V305 entdämpft mit ihrer negativen Impedanz den Schwingkreis. Über einen Trennverstärker (N300) wird das Oszillatorsignal am Emitter ausgekoppelt.

Über einen ohmschen Leistungsteiler verteilt sich das Signal auf den Ausgangsverstärker (V330) sowie den Frequenzteiler (B360), der das Signal für die PLL auf 10 MHz herunterteilt.

Der Ausgangsverstärker mit einem "Dual Gate MESFET" (V330) verstärkt das Oszillatorsignal auf ca 10 dBm (X125, REF640). Ist der Mischerzweig im Ausgangsteil nicht aktiv, so läßt sich über die Schalttransistoren (V340, V345) der Ausgangspegel über das Gate2 des Ausgangsverstärkers um mehr als 40 dB absenken (Steuersignal S-Ref 640).

Das über den Festteiler durch 64 erzeugte Signal wird mit der Transistorstufe V370 auf TTL-Pegel gewandelt (Meßpunkt P354) und wird am Phasendetektor (D255) mit der 10-MHz-Referenzfrequenz verglichen. Die Ausgangsspannung des PI-Reglers (N250) stimmt den Oszillator ab, die Bandbreite der PLL beträgt ca. 300 Hz.

Der Pegel des 640-MHz-Ausgangsverstärkers wird von einem Diagnosegleichrichter (V347) gemessen. Die Regelspannung der PLL wird von einem Fensterkomparator (N105) überwacht.

7.1.2 Synthesizer 65...1040 MHz

7.1.2.1 Oszillatoren 520..1040 MHz

Zwei Oszillatoren mit einem Abstimmbereich von jeweils 260 MHz erzeugen die Frequenz der Grundoktave. Ein Transistor mit einer negativen Impedanz an der Basis (V404 und V434) entdämpft den Serienschwingkreis, der aus einem Porzellankondensator (C402 und C432), einer gedruckten Induktivität und zwei mal zwei parallel geschalteten Kapazitätsdioden (V400-V403 und V430-V433) besteht. Durch die geringen Toleranzen der schwingkreisbestimmenden Elemente ist kein Frequenzabgleich der Oszillatoren notwendig. Eine Stromquelle (V406 und V436), deren Versorgungsspannung über eine Transistorstufe ein- und ausgeschaltet werden kann, stabilisiert den Arbeitspunkt des Oszillators über den Abstimmbereich. Über einen PIN-Schalter (V490 und V492) wird das Ausgangssignal, je nach aktivem Oszillator, zu der Trennstufe N490 geführt. Ein ohmscher Leistungsteiler verzweigt das Oszillatorsignal auf die Ausgangsteiler sowie den Fractional-N-Teiler der PLL.

7.1.2.2 Ausgangsteiler

Die Ausgangsfrequenzen von 65...520 MHz werden durch Frequenzteilung durch zwei, vier und acht realisiert. Es werden ein Teiler durch 2 (D510) und ein Teiler durch 4 (D520) verwendet. Durch Kettenschaltung der beiden Teiler entsteht der Teilerfaktor acht. Die einzelnen Signalpfade werden über PIN-Schalter (S1...S6) geschaltet. Die Teilerbausteine werden über die Versorgungsspannung mit den Transistoren V510 und V520 ein- und ausgeschaltet. Der Ausgangsverstärker N560 erhöht den Pegel auf ca. 8..12 dBm. Dieser Ausgangspegel wird über den Diagnosegleichrichter V555 überwacht.

7.1.2.3 Fractional-N-Teiler und PLL

Die Ausgangsoszillatoren werden in einer PLL mit einem Fractional-Divider auf die Referenzfrequenz von 2 MHz geregelt. Dieser Schaltungsteil ist im Gatearray FRACSYN (D65) integriert.

Die beiden MMIC-Verstärker N600 und N610 entkoppeln die Teilerschaltung von den Oszillatoren. Die beiden Frequenzteiler (D620 und D630) teilen die Oszillatorfrequenz durch 16 und liefern somit Eingangsfrequenzen von 32.5...65 MHz für den FRACSYN, der die eigentliche Fractional-Teilung durchführt (Meßpunkt P600).

Der Baustein FRACSYN berechnet für jede Referenzperiode, aus dem über eine serielle Schnittstelle programmierten Teilungsfaktor sowie dem eingestellten Hub, den neuen Teilungsfaktor. Dessen Ausgangstakt CKO von 2 MHz wird mit dem Synchronisierflipflop D655 auf den Eingangstakt des FRACSYN synchronisiert. Das synchronisierte 2 MHz Signal gelangt von hier zum Phasendetektor D700. Die aus dem Phasenvergleich mit der 2 MHz Referenzfrequenz (2REF) gewonnenen UP/DOWN-Ausgangssignale des Phasendetektors werden in dem Differenzverstärker N710 addiert (Meßpunkt P700). Die Verstärkung des folgenden PI-Reglers (N720) läßt sich zur Kompensation der Verstärkungsänderungen in der PLL, hervorgerufen durch den unterschiedlichen Teilungsfaktor sowie die unterschiedliche VCO-Steilheit, mit einem Analogmultiplexer (D720) in 8 Stufen einstellen. Eine Transistorendstufe (V750 und V755) mit Diodenumschaltung der PLL-Bandbreite (V765...768) beschleunigt den Einschwingvorgang der Regelschleife bei Frequenzwechsel. Die Ausgangsspannung des PI-Reglers (A-PI-SYN) wird von einem Fensterkomparator überwacht (N110). Die Abstimmspannung der Oszillatoren kann über eine Diagnosestelle gemessen werden.

7.1.3 FM/ϕM Modulation

7.1.3.1 Funktionsprinzip

Durch die Verwendung eines Bruchteilers mit einem digitalen Modulationseingang läßt sich eine relativ einfache und dennoch präzise FM AC/DC und ϕM-Schaltung realisieren.

Dabei wird die Modulation über zwei Pfade mit unterschiedlichen Frequenzgängen übertragen. In dem ersten Pfad wird bei FM nach A/D-Wandlung mit einem Sigma-Delta-Wandler direkt der Teilungsfaktor und damit die momentane Mittenfrequenz moduliert. Dieser Teil hat die Tiefpaßfunktion für die Nutzübertragung einer PLL, gleichzeitig ist hier die PLL ein Tiefpaß für das Quantisierungsgeräusch des A/D-Wandlers. In dem zweiten Pfad wird direkt der Oszillator moduliert, dieser Teil hat die Hochpaßfunktion für die Störübertragung einer PLL. Bei gleicher Empfindlichkeit und Laufzeit in beiden Zweigen ergibt sich ein ebener Frequenzgang mit konstanter Gruppenlaufzeit.

ϕM wird durch Differenzieren der Modulationsspannung erzeugt. Die Grenzfrequenz des Differenzierers liegt bei 40 kHz. Eine DC-Modulation ist somit bei ϕM nicht möglich. Die Übertragungsfunktionen sind die gleichen wie bei FM.

7.1.3.2 FM/ϕM-Hubteiler

Zur Einspeisung der Modulationssignale stehen die zwei Eingänge INT1 und EXT1 zur Verfügung. Der externe Modulationseingang verfügt über einen hochohmigen Eingangsverstärker (N800) mit umschaltbarer AC/DC-Kopplung (D820). Die Eingangsimpedanz kann über die Steckbrücke X80 gewählt werden. Sie beträgt 100 kΩ oder 600 Ω. Über den Schalter D800 wird das gewünschte Modulationssignal ausgewählt. Dabei ist eine Einton- (Extern oder Intern) sowie Zweitonmodulation (Extern und Intern) möglich. Die Verstärker N845 und N850 verstärken das Eingangssignal von $1V_S$ auf $6V_S$. Über den Verstärker N850 wird dazwischen das Signal für den Sigma-Delta-Wandler abgezweigt. Der hier fließende Strom ist immer konstant. Im Steuerzweig für die Modulation über die Oszillatoren wird zur Feineinstellung des Hubes ein multiplizierender 12 Bit D/A-Wandler (D840) verwendet. Der folgende Operationsverstärker führt eine Impedanzwandlung durch.

Zur Grobeinstellung des Hubes am Oszillator wird eine Eichleitung in Kettenleiterstruktur mit 12 dB Schritten verwendet (dividiert 1...4096). Die Abgriffe werden von dem Analogmultiplexer D960 geschaltet. Bei ausgeschalteter Modulation wird über einen FET (N960) der Oszillatoreingang auf Masse gelegt um so das Widerstandsrauschen zu minimieren.

Die Hubwertigkeit für die Modulation des Teilungsfaktors über den Sigma-Delta-Wandler wird grob intern im FRACSYN und fein über die ADWE-Eingänge (Schieberegister D660 und D665) mit 16 Bit Auflösung eingestellt.

Für ϕ M wird in den gemeinsamen Zweig eine Differenzierschaltung (Reedrelais K910) eingeschaltet. Die Übertragungswege sind ansonsten identisch zur FM.

Der Pegel am EXT-Eingang wird von der Fensterkomparatorschaltung mit N860 und D870 überwacht. Bei Abweichung vom Sollpegel von 1...3 % wird je nach Richtung, der Interrupt FMKOMPFI (Eingespeiste Spannung zu groß) oder FMKOMPLO (Eingespeiste Spannung zu klein) ausgelöst.

7.1.3.3 Sigma-Delta-Wandler und FM-DC Regelung

Zur Modulation des Teilungsfaktors wird ein Sigma-Delta-Wandler 3.ter Ordnung (N940, N950, N960, D950 und D965) eingesetzt, der das analoge Modulationssignal in ein digitales Signal umwandelt. Der gleitende Mittelwert des 1 Bit Ausgangssignals entspricht dabei der analogen Eingangsgröße. Das dabei entstehende Quantisierungsgeräusch wird durch die Tiefpaßfunktion der PLL gefiltert. Eine Laufzeitentzerrerschaltung am Eingang des Wandlers sorgt für gleiche Gruppenlaufzeit in beiden Modulationswegen. Da alle Offsetspannungen auch bei AC-Betrieb zu einer Verschiebung der Mittenfrequenz führen, werden diese durch eine Mittelwertregelung kompensiert. Bei FM-DC muß die Regelung geklemmt werden, um die DC-Modulationsspannung nicht auszuregeln. Dieser Schaltungs- teil befindet sich ebenfalls im Gatearray FRACSYN.

7.1.4 Kalibrierroutinen

7.1.4.1 VCO-Kalibrierung

Es wird im 5 MHz Raster eine Tabelle der jeweiligen Abstimmspannung der Oszillatoren angelegt. Aus diesen, über die Diagnose ermittelten Werten, kann die jeweilige Oszillatorsteilheit $k_o(f)$ berechnet werden. Zwischenwerte werden hierbei linear interpoliert. Sie wird benötigt um die notwendige PLL-GAIN zu ermitteln, mit der die Verstärkungsschwankungen in der Regelschleife kompensiert werden. Die ermittelten Steilheitswerte werden ebenfalls als Startwerte zur Berechnung der Hubsteilheit für die FM-Kalibrierung benötigt.

7.1.4.2 FM-Kalibrierung

Für die Kalibriertabelle der Hubsteilheit mißt ein Diagnosedetektor (N780, V781, C782) bei einer Modulationsfrequenz von 1 kHz den Differenzhub in der Regelschleife. In einer Abgleichroutine werden die Stellglieder des FM/PHIM-Hubteilers so lange verändert, bis der gemessene Differenzhub minimal wird. Aus den so ermittelten Einstellwerten wird die Modulationssteilheit des Oszillators bei der jeweiligen Frequenz berechnet. Diese Tabelle wird ebenfalls im 5 MHz Raster aufgenommen.

7.2 Meßgeräte und Hilfsmittel

- HF-Spektrumanalysator (FSA)
- HF-Signalgenerator (SMGU, SME)
- Funktionsgenerator $f \geq 2$ MHz, (AFGU, AFS)
- Oszilloskop $f > 250$ MHz
- AC/DC-Voltmeter (URE3)
- Modulationsanalysator mit Klirrfaktormesser (FMA, FMB)

7.3 Fehlersuche

Zur Fehlerdiagnose eignet sich ebenso das im Servicekit SMY-Z1 enthaltene Prüfprogramm, das umfangreiche Diagnosemöglichkeiten bietet.

7.3.1 Synchronisierfehler

Die Fehlermeldungen Error 1 bis Error 3 sind eine Veroderung der Fehlerüberwachungen der Phasenregelschleifen für den 10 MHz TCXO, den 640 MHz Oszillator sowie der PLL der Ausgangsoszillatoren. Ist ein Fehler an der 10 MHz PLL vorhanden, so kann dies auch zu einem Ausrasten der anderen Regelschleifen führen. Über den entsprechenden Diagnosepunkt kann jeweils nachgeprüft werden, welche der drei Phasenregelschleifen außer Toleranz sind.

Fehlermeldung "Error 1"
10-MHz-Referenzloop außer Synchronisation

Prüfen ob in der Betriebsart ext. Referenz die richtige Frequenz mit ausreichendem Pegel eingespeist wird

Überprüfen der externen Referenz nach 7.4.2.2

Überprüfen des Fensterkomparators N100

Fehlermeldung "Error 2"
640-MHz-Loop außer Synchronisation

Überprüfen ob 10 MHz Referenzfrequenz am Phasendetektor D255.11 anliegt

Überprüfen des 640 MHz Oszillators und der PLL nach 7.4.3.1

Überprüfen des Fensterkomparators N105

Fehlermeldung "Error 3"
Hauptoszillator-Loop außer Synchronisation

Ausgangsoszillatoren nach 7.4.4 überprüfen

Nachmessen ob 2 MHz Referenzsignal am Phasendetektor D700.3 anliegt. PLL der Ausgangsoszillatoren nach 7.4.5 überprüfen

Überprüfen des Fensterkomparators N110

7.3.2

Fehler bei CW-Betrieb

Kein Ausgangspegel oder Ausgangspegel zu gering an X124

Ausgangssoszillatoren nach 7.4.4 überprüfen

Ausgangsteiler mit Teilern nach 7.4.6 überprüfen

Nachprüfen der Arbeitspunkte bzw. der HF-Pegel der sich im Pfad befindenden Verstärker (Tabelle 7.4.13.3)

**Störhub zu groß
(keine Nebenwellen)**

Kalibrierroutine VCO mit **SPEC 41** durchführen

Oszillatoren nach 7.4.4 überprüfen, ebenso deren Arbeitspunkte nach Tabelle 7.4.13.3

Störhub der Oszillatoren messen, die eingespeiste DC-Spannung muß ausreichend brumm- und rauschfrei sein

PLL der Ausgangssoszillatoren nach 7.4.5.1-7.4.5.3 überprüfen, Versorgungsspannungen von FRACSYN und Phasendetektor nachprüfen (7.4.1)

Nebenwellen > -70 dBc für Ablagefrequenzen > 5 kHz zum Träger

Kalibrierroutine VCO mit **SPEC 41** durchführen

Phasenoffset des Phasendetektors überprüfen, DC-Spannung an C701 sollte 1.65 V betragen

Versorgungsspannung FRACSYN und Phasendetektor überprüfen (7.4.1)

7.3.3

Fehler bei FM-/ ϕ M-Modulation

**Hubfehler bei FM oder ϕ M;
Stereoübersprechen außer Toleranz
Starke Modulationsverzerrungen bei Maximalhub**

Kalibrierroutine FM mit **SPEC 43** durchführen

Prüfen des Hubteilers nach 7.4.7

Überprüfung der Hubeinstellung nach 7.4.9

FM-Klirrfaktor zu groß

Kalibrierroutine FM mit **SPEC 43** durchführen

Prüfen des Hubteilers nach 7.4.7, Klirrfaktor des Modulationssignals an X84 überprüfen

Überprüfen der FM-Kalibration nach 7.4.10.3

Keine oder falsche FM-Modulation bei Modulationsfrequenzen kleiner 1 kHz	Sigma-Delta-Wandler nach 7.4.9 überprüfen Abgleich FM-Hub nach 7.4.10.2 durchführen
Keine oder falsche FM-Modulation bei Modulationsfrequenzen größer 1 kHz	Kalibrierroutine FM mit SPEC 43 durchführen Hubteiler nach 7.4.7 überprüfen
FM-Frequenzgang zu groß	Hubteiler nach 7.4.7 überprüfen Frequenzgang auch nach dem Grobteiler an D960.3 nachmessen (eingestellter FM-Hub > 3 MHz, RF > 520 MHz)
Mittenfrequenzfehler bei FM-DC Modulation, bzw. FM-DC-Mittenfrequenzkalibrierung (Specialfunktion 55) wird nicht richtig ausgeführt)	Sigma-Delta-Wandler und FM-DC Regelung nach 7.4.9 überprüfen
Keine oder falsche ϕ M-Modulation	Überprüfen ob eine äquivalente eingestellte FM-Modulation richtig ist, ansonsten Fehler beim PM-Differenzierer (Hochpass mit C913 und R848, wird überprüft in 7.4.7) (äquivalente FM = eingestellte PM * eingespeiste NF-Frequenz)

7.3.4 Kalibrierungen

Fehlermeldung "Error 15" Kalibrierung VCO fehlerhaft	Ausgangszillatoren nach 7.4.4 überprüfen PLL der Ausgangszillatoren nach 7.4.5 überprüfen Einschwingverhalten der Synthese nach 7.4.11 überprüfen
Fehlermeldung "Error 15" Kalibrierung FM fehlerhaft	Überprüfen des FM-Diagnosedetektors nach 7.4.10.1, der Offset des Diagnosedetektors (Testpunkt 15 über Diagnose messen, keine NF-Frequenz einspeisen) muß kleiner 50 mV sein Überprüfen des Hubteilers nach 7.4.7 Sigma-Delta-Wandler nach 7.4.9 überprüfen Laufzeitverzerrung am Eingang Sigma-Delta-Wandler prüfen

7.4 Prüfen und Abgleich

Alle Meßwerte ohne Toleranzangaben sind als Richtwerte zu verstehen. Spannungsangaben ohne weitere Bezeichnung bedeuten DC-Spannungen.

Wird die Baugruppe mit geöffnetem Deckel betrieben, so müssen die zwei Oszillatorkammern mit Prüfdeckeln auf der Bauteil- und Lötseite geschlossen werden.

Vor allen Prüfungen ist mit **PRESET** der SMY in einen definierten Anfangszustand zu bringen.

7.4.1 Datenübertragung und Stromversorgung

(Hierzu Stromlaufblatt 9)

Gemäß Gerätestandard wird die Baugruppe über eine serielle Schnittstelle angesteuert. Die Datenübertragung erfolgt hierbei auf zwei verschiedenen Subadressen. Die Datenübernahme erfolgt mit den beiden Baugruppenstrobes HF1STB und HF2STB. Die Einstellungen und die zugehörigen Daten sind im Kapitel 'Digitale Schnittstellen' zu finden.

Die Stromaufnahme kann überprüft werden, indem anstelle der Spulen L1 bis L5 ein Amperemeter eingeschleift wird. Die Sollwerte sind im Kapitel 'Externe Schnittstellen' zu finden.

Die wichtigsten Referenz- bzw. Versorgungsspannungen werden mit dem DC-Voltmeter nachgemessen.

Meßpunkt	Art der Spannung	Spannung [V]
P20	10 V Referenz	+9.9...+10.1
P21	Versorgungssp. 5 V analog	+5.1 ... +5.4
D700_14	Versorgungssp. Phasendetektor	4.6...5.0 V
D65_84	Versorgungssp. FRACSYN	5.1...5.5 V

7.4.2 Referenzfrequenzerzeugung

7.4.2.1 Referenz Intern

(Hierzu Stromlaufblatt 2)

Für verschiedene D/A-Wandler Werte wird die Abstimmspannung für die interne Referenz über die Diagnose abgelesen (Funktion D/A-Wandler). Auf dem Oszilloskop muß ein 10 MHz HCMOS Signal sichtbar sein (Funktion Pegelwandler). Mit dem Spektrumanalysator kann der Ausgangspegel EXTREF gemessen werden.

- Oszilloskop mit Tastkopf an P201 anschliessen
- Spektrumanalysator an EXTREF (Geräterückwand) anschliessen
- Einstellungen: **SPEC 111**
 RF INT/ON

Die D/A-Wandler-Werte über die Specialfunktion 51 nach Tabelle einstellen und die Diagnosespannung überprüfen. Die eingegebenen Kalibrierwerte werden durch das Drücken der ENTER-Taste übernommen.

SPEC 51	Diagnosespannung am Testpunkt 11
0	± 150 mV
4095	4.7...5.3 V
2048	2.3...2.7 V

- _ Signal an P201 prüfen: 10 MHz, HCMOS
- _ Ausgangssignal am Spektrumanalysator messen: 10 MHz, 7.5 ± 2 dBm

7.4.2.2 Referenz Extern

(Hierzu Stromlaufblatt 2)

Es wird zuerst der Eingang der Externen Referenz mit der Vervielfacherschaltung getestet.

- Signalgenerator 5 MHz an EXTREF (Geräterückwand) anschließen.
- Oszilloskop mit Tastkopf an P204 anschließen.
- Einstellungen: **RF EXT AC**

- _ Signal an P204 prüfen: 10 MHz, HCMOS-Pegel für Eingangspegel von -13...13 dBm am Eingang EXTREF.

Nun erfolgt die Prüfung der PLL und des Ziehbereiches des VTCXO's. Hierbei wird die Regelspannung über die Diagnose überprüft.

- Einstellungen: **SPEC 111**
- Frequenz des Signalgenerators nach Tabelle einspeisen, Pegel: 7 dBm.

- _ Diagnosespannung nach Tabelle prüfen.

Frequenz an EXTREF	Diagnosespannung Testpunkt 11
10 MHz	2.5 ± 0.5 V
9.999970 MHz	> 0.5 V
10.000030 MHz	< 4.5 V

7.4.3 640 MHz Referenz

7.4.3.1 Oszillator 640 MHz und PLL

(Hierzu Stromlaufblatt 2 und 3)

Es wird die Funktion sowie der Abstimmbereich des Oszillators geprüft.

- Brücke X20 ziehen und Netzgerät (0...20 V) an X20.2 und X20.3 (Masse) anschließen.
- Spektrumanalysator mit Einstellung CF 640 MHz, SPAN 50 MHz und REF LEVEL 10 dBm an X125 anschließen.

- Einstellungen: **RF 50 MHz**

- _ Abstimmspannung von 0...20 V variieren, der Oszillator muß im gesamten Abstimmbereich bei 640 ± 20 MHz ohne Aussetzer, Nebenlinien oder Rauschüberhöhungen schwingen.
- _ Abstimmspannung zwischen 2 und 18 V umschalten, die Frequenzänderung des Oszillators muß > 15 MHz und < 25 MHz sein.
- _ Die Abstimmspannung für 640 MHz muß > 4V und < 16V sein.

- Netzgerät wieder entfernen und Brücke X20 auf 1-2 stecken.

Bei geschlossener PLL wird nun die Abstimmspannung über die Diagnose gemessen.

- Einstellungen: **SPEC 112**

_ Diagnosespannung am Testpunkt 12: 10 ± 6 V

7.4.3.2 Ausgangsverstärker 640 MHz

(Hierzu Stromlaufblatt 3)

Der Ausgangspegel wird bei ein- und ausgeschaltetem Signal überprüft.

- Spektrumanalysator mit Einstellung CF 640 MHz, SPAN 50 MHz, REF LEVEL 15 dBm an X125 anschließen.

- Einstellungen: **RF 50 MHz**
SPEC 113

_ Pegel 640 MHz am Spektrumanalysator messen: 10 ± 2 dBm.

_ Diagnosespannung am Testpunkt 13: 100...400 mV.

Die Frequenz des SMY wird nun so eingestellt, daß der LO-Verstärker abgeschaltet wird.

- Einstellungen: **RF 100 MHz**

_ Pegel 640 MHz am Spektrumanalysator messen: < -30 dBm.

7.4.4 Ausgangsoszillatoren

(Hierzu Stromlaufblatt 4, 5 und 7)

Es muß unbedingt der bauteilseitige und der lötseitige Trimmdeckel auf den Oszillatorkammern geschraubt sein.

Es wird die Funktion der beiden Ausgangsoszillatoren sowie deren Abstimmbereich überprüft. Die Diagnosespannung für den Ausgangspegel wird ebenfalls überprüft.

- Spektrumanalysator mit Einstellung CF 780 MHz, SPAN 800 MHz, REF LEVEL 15 dBm an X124 anschließen.
- Brücke X75 entfernen und Netzgerät an X75.2 und X75.3 (Masse) anschließen.

_ Die Abstimmspannung wird für beide Oszillatoren von 0...22 V variiert, der Oszillator muß im gesamten Abstimmbereich ohne Aussetzer, Nebenlinien und Rauschüberhöhungen schwingen. Bei der unteren und oberen Frequenzgrenze beider Oszillatoren muß die Abstimmspannung im angegebenen Toleranzfenster (siehe Tabelle) liegen. Der Ausgangspegel an X124 muß zwischen 7 und 14 dBm liegen.

Einstellung	Oszillator	min. Freq.	Abstimmsp.	max. Freq.	Abstimmsp.
RF 600 MHz	:	520 MHz	1.75...4 V	780 MHz	16.5...19.5 V
RF 900 MHz	:	780 MHz	1.75...4 V	1040 MHz	16.5...19.5 V

Bei einer Ausgangsfrequenz von ca. 1040 MHz wird noch die Diagnose getestet.

Einstellungen: **SPEC 114**

_ Diagnosespannung am Testpunkt 14: 80...400 mV

- Netzgerät entfernen und Brücke X75 wieder auf 1-2 stecken.

7.4.5 PLL der Ausgangsoszillatoren

Um mögliche Fehler in einer Phasenregelschleife zu erkennen ist es sinnvoll diese aufzutrennen und die Fehlersuche an der geöffneten PLL durchzuführen. Hierzu bleibt die Steckbrücke X75 während den Prüfungen 7.4.5.1 - 7.4.5.3 entfernt.

Um besser die eingestellte Ausgangsfrequenz verfolgen zu können, sollte man einen Spektrumsanalysator an X124 anschliessen.

7.4.5.1 Überprüfung der Teiler in der PLL

(Hierzu Stromlaufblatt 6)

Es wird zunächst die Teilerkette im Rückwärtszweig der PLL geprüft.

- Brücke X75 entfernen und Netzgerät an X75.2 und X75.3 (Masse) anschließen.
- Spannung am Netzteil auf ca. 16 V einstellen (Oszillator 2 schwingt auf ca. 1000 MHz)
- Oszilloskop mit Tastkopf an P600 anschließen.

• Einstellungen: **RF 1000 MHz**

_ Signal an P600 prüfen: ca. 62.5 MHz, TTL-Pegel

- Oszilloskop mit Tastkopf an P610 anschließen.

_ Signal an P610 prüfen: ca. 2 MHz, HCMOS-Pegel

7.4.5.2 Überprüfung des Phasendetektors

(Hierzu Stromlaufblatt 7)

Bei der Überprüfung des Phasendetektors wird zunächst sichergestellt, daß die Referenzfrequenz (Signal 2REF), auf die synchronisiert wird, richtig anliegt.

• Einstellungen: **RF 1000 MHz**

_ Signal an D700.3 mit Tastkopf an Oszilloskop überprüfen: 2 MHz, HCMOS-Pegel

- Oszilloskop mit Tastkopf nun an P700 anschließen.
- Spannung am Netzteil an X75 etwas reduzieren, sodaß die Ausgangsfrequenz des Oszillator2 kleiner als 1000 MHz ist.

_ Abfallende Sägezahnspannung an P700 mit der Differenzfrequenz der beiden Eingangssignale, DC-Spannung an P700 ist negativ (ca. - 0.8 V)

Abbildung 1

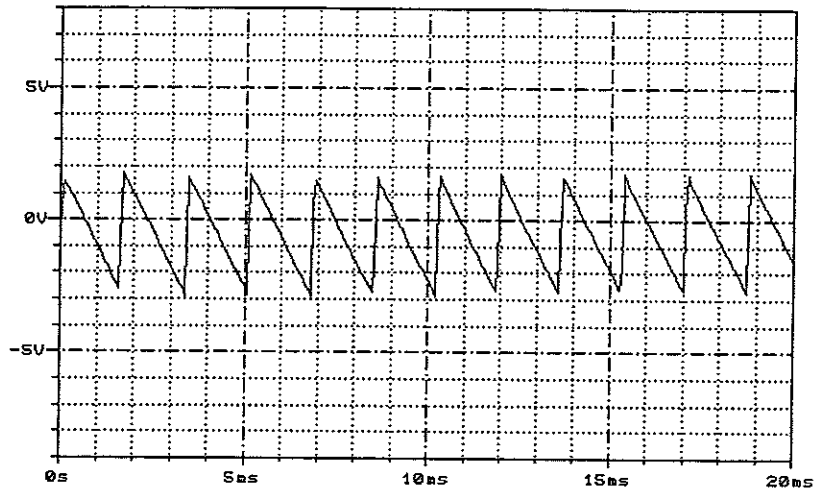

- Spannung am Netzteil an X75 nun langsam erhöhen, sodaß die Ausgangsfrequenz des Oszillator2 größer als 1000 MHz wird. Hierbei wird die Spannung an P700 beobachtet.
- Ansteigende Sägezahnspannung an P700 mit der Differenzfrequenz der beiden Eingangssignale, DC-Spannung an P700 ist positiv (ca. 4 V)

Abbildung 2

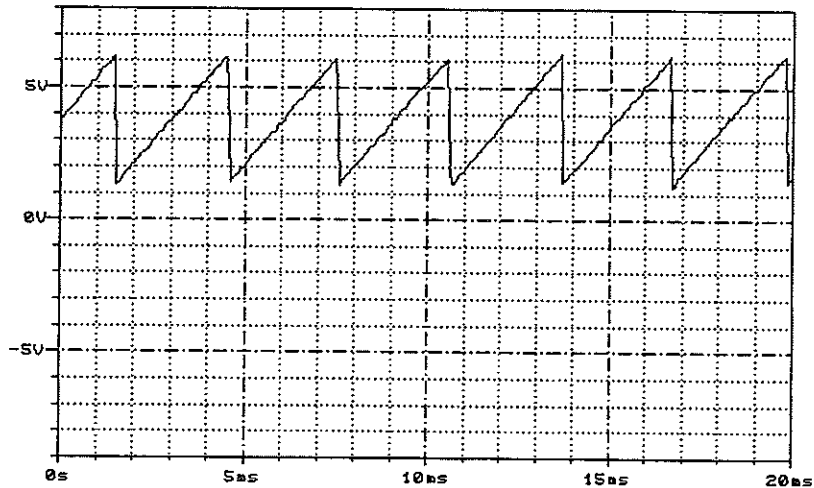

7.4.5.3 Überprüfung des Regelfilters

(Hierzu Stromlaufblatt 7)

Eine exakte Überprüfung des integralen Regelverstärkers bei einer geöffneten Regelschleife ist nicht möglich. Es wird daher nur auf grobe Funktionalität überprüft.

- Oszilloskop mit Tastkopf an P720 anschließen.
- Einstellungen: **RF 1000 MHz**

Die Vorgehensweise bei der Funktionalitätsüberprüfung des Regelverstärkers ist identisch zur Überprüfung des Phasendetektors. Hierzu wird die eingespeiste DC-Spannung an X75 zunächst reduziert, sodaß der Oszillator unter 1000 MHz schwingt. In den integralen Regler fließt nun ein negativer Eingangsstrom, der dessen Ausgangsspannung auf ca. 21..24 V an P720 anwachsen läßt. Wird die Spannung an X75 erhöht, sodaß der Oszillator nun über 1000 MHz schwingt fließt in den integralen Regler ein positiver Eingangsstrom, sodaß dessen Ausgangsspannung auf ca. 0 V absinkt. Ist die eingestellte Differenzfrequenz sehr gering, kann der DC-Spannung an P720 noch eine AC-Spannung mit der entsprechenden Differenzfrequenz überlagert sein.

Es empfiehlt sich auch die Spannung nach dem folgenden Tiefpassfilter zu überprüfen (Spannung an X75.1). Sie muß identisch zur Spannung an P720 sein.

- Netzgerät entfernen und Brücke X75 wieder auf 1-2 stecken.

7.4.5.4 Überprüfen der geschlossenen PLL

(Hierzu Stromlaufblatt 4, 6 und 7)

Nach Stecken der Brücke X75 ist die PLL nun geschlossen.

- Einstellungen: **RF FREQUENCY (nach Tabelle)**
SPEC 115
- Spektrumanalysator mit Einstellung CF=**FREQUENCY**, Span 100 kHz, Rev.lev. 15 dBm an X124 anschliessen.

Das Ausgangssignal wird bei den verschiedenen RF-Einstellungen überprüft. Es dürfen keine Seitenlinien oder Rauschüberhöhungen auf dem Spektrumanalysator sichtbar sein.

FREQUENCY	Diagnosespannung Testpunkt 15
520 MHz	1.75...4 V
779.999999 MHz	16.5...19.5 V
780 MHz	1.75...4 V
1040 MHz	16.5...19.5 V

7.4.6 Ausgangsstufe mit Teilern

(Hierzu Stromlaufblatt 5)

Es werden die Ausgangsteiler durch 2, 4 und 8 überprüft. Die Diagnosespannung und der Ausgangspegel werden ebenfalls gemessen. Für diese Prüfung wird vorausgesetzt, daß die PLL und die Ausgangsoszillatoren einwandfrei arbeiten und sich somit alle Frequenzen der Grundoktave von 520...1040 MHz einstellen lassen.

- Einstellungen: **RF FREQUENCY (nach Tabelle)**
SPEC 114

- _ Überprüfen der eingestellten Frequenz sowie des Ausgangspegels am Spektrumanalysator nach Tabelle.
- _ Spannung am Testpunkt 14 für alle RF-Frequenzen: 80...600 mV

FREQUENCY	Teiler	Pegel an X124
1040 MHz	1	7...14 dBm
780 MHz	1	7...14 dBm
779 MHz	1	7...14 dBm
520 MHz	1	7...14 dBm
500 MHz	2	7...14 dBm
250 MHz	4	7...14 dBm
125 MHz	8	7...14 dBm

7.4.7 Prüfen des Hubteilers

(Hierzu Stromlaufblatt 8)

Es werden die Modulationsmatrix für beide Kanäle, die AC/DC-Umschaltung für den externen Eingang, der Differenzierer für PHIM sowie der Feinhubteiler geprüft.

- Steckbrücke X84 entfernen.
- Modulationssignal an der Eingangsbuchse EXT an der Fronteinheit nach Tabelle einspeisen, mit AC/DC-Voltmeter an Meßpunkten nach Tabelle die Sollspannungen nachmessen.
- Einstellungen: **RF 1000 MHz**

Einstellung	Signal an EXT	Signal an F840	Signal an X84.1
FM EXT DC 10 MHz	1 V	- 3.32 ± 0.1 V	- 6...- 1.5 V (Referenzwert)
AF 1 kHz, FM INT 10 MHz	-	3.32 ± 0.1 Vs	- 6...- 1.5 Vs (=Referenzwert) DC < 40 mV
FM EXT AC 10 MHz	2 MHz, 1 Vs	3.32 ± 0.2 Vs	Referenzwert ± 3 dB DC < 40 mV
PHIM EXT 175 rad	20 kHz, 1 Vs	3.32 ± 0.1 Vs	Referenzwert - 10 dB (± 1 dB)

Es erfolgt nun die Überprüfung der Feinhubteiler

- Einstellungen: **RF 1000 MHz**
AF 1 kHz
FM INT 0 Hz
FM STEP 100 Hz

- _ Den FM-Hub mit dem Drehknopf am Frontmodul von 0 Hz bis 2.5 kHz in 100 Hz Stufen variieren. Die NF-Spannung an X84.1 muß von 0 V bis ca. 3.2 V_S in gleichen Schritten (ca. 0.13 V) ansteigen.

7.4.8 EXT-Überwachung

(Hierzu Stromlaufblatt 8)

- NF-Generator, 1 kHz, Pegel nach Tabelle, an EXT anschliessen.
- _ Die Funktion der Pegelüberwachung nach Tabelle prüfen.

- Einstellungen: **FM EXT AC 100 kHz**

Eingangsspannung an EXT	Anzeige
$1 \pm 0.005 \text{ Vs}$	-
$1.03 \pm 0.005 \text{ Vs}$	EXT-HIGH
$0.97 \pm 0.005 \text{ Vs}$	EXT-LOW

7.4.9 Sigma-Delta-Wandler mit FM-DC-Regelung

(Hierzu Stromlaufblatt 8)

Es wird die Funktion des Sigma-Delta-Wandlers sowie der FM-DC-Regelung in den Betriebsarten FM-AC und FM-DC geprüft.

- Einstellungen: **RF 1000 MHz**
- DC-Spannungsquelle (0...1V) an den Modulationseingang EXT anschließen.
- _ Die angegebenen DC-Spannungen mit einem DC-Voltmeter nach Tabelle prüfen.

Einstellung	DC-Spannung an EXT	DC-Spannung an D950.9	DC-Spannung an D65.75
FM EXT AC 10 MHz	0 V	$2.6 \pm 0.2 \text{ V}$	$2.6 \pm 0.2 \text{ V}$
FM EXT DC 10 MHz	0 V	$2.6 \pm 0.25 \text{ V}$	$2.6 \pm 0.25 \text{ V}$
FM EXT DC 10 MHz	1 V	$3.8 \pm 0.2 \text{ V}$	$2.6 \pm 0.25 \text{ V}$

7.4.10 FM-Hubeinstellung

7.4.10.1 Überprüfung FM-Diagnosedetektor

(Hierzu Stromlaufblatt 7 und 8)

Bei der Durchführung der FM-Kalibration wird mit einem FM-Diagnosedetektor der Differenzhub in der Regelschleife gemessen. Zur Prüfung des Detektors wird nun ein definierter Frequenzhub eingestellt, und eine Aussteuerungsmessung mit dem Detektor vorgenommen.

- Einstellungen: **RF 1000 MHz**
FM EXT AC 50 kHz
SPEC 116
- NF-Generator, $1 \text{ V}_S \pm 5 \text{ mV}$, 1 kHz, an den Eingang EXT anschliessen.
- Steckbrücke X84 entfernen.
- _ Diagnosespannung an Testpunkt 16: $1.6 \pm 0.4 \text{ V}$.
- Eingespeiste NF-Frequenz auf 500 Hz, danach auf 1.5 kHz einstellen.
- _ Diagnosespannung an Testpunkt 16: $< 0.5 \text{ V}$.
- Steckbrücke X84.1/2 wieder bestücken.

7.4.10.2 Abgleich FM-Hub

(Hierzu Stromlaufblatt 8)

Es wird der Maßstab des FM-Hubes über den Regelungszweig (Steuerung des Teilungsverhältnisses am FRACSYN) abgeglichen.

- Einstellungen: **RF 1000 MHz**
 FM EXT AC 500 kHz
- NF-Generator, $1 V_s \pm 5 \text{ mV}$, 50 Hz, an den Eingang EXT anschliessen.
- Modulationsanalysator mit Einstellung HP 10 Hz, TP 3 kHz, Detektor RMS*², an X124 anschliessen.

_ Mit R930 auf $500 \pm 1 \text{ kHz}$ FM-Hub abgleichen.

_ Mit **SPEC 43** FM-Kalibration durchführen.

7.4.10.3 Überprüfung der FM-Kalibrierung

(Hierzu Stromlaufblatt 7)

Mit dem Diagnosedetektor wird der Differenzhub bei FM-Modulation in der PLL nach erfolgter Kalibrierung durchgeführt (siehe 7.4.10.2). Die Überprüfung erfolgt in der Grundoktave von 520 bis 1040 MHz in 5 MHz Schritten.

- Einstellungen: **RF 520 MHz**
 FM INT 500 kHz
 AF 1 kHz
 SPEC 116
 RF STEP 5 MHz

_ Die Frequenz von 520 MHz bis 1040 MHz mit dem Drehknopf erhöhen. Die Diagnosespannung am Testpunkt 16 muß bei jeder Frequenz im Bereich $0 \pm 50 \text{ mV}$ sein.

7.4.11 Einschwingverhalten der Synthese

Es wird das Einschwingverhalten der PI-Reglerspannung bei einem Frequenzsprung zwischen 520 und 1040 MHz gemessen.

- Einstellungen: **RF 520 MHz**
 FM OFF
 RF EXT AC
- Buchse EXTREF des Spektrumanalysators mit Buchse EXTREF an der Rückwanne des SMY verbinden.
- Tastkopf an Baugruppenstrobe HF2STB an X1A.16 anschliessen und mit dem Eingang EXT SWEEP TRG an der Rückwanne des Spektrumanalysators verbinden.
- Spektrumanalysator mit Einstellung CF 1040 MHz, SPAN 0 Hz, REF LEVEL 10 dBm, LOG RANGE 20 dB, SWEEP 100 ms, RES BW 2.023 kHz, TRIGGER EXTERNAL, SLOPE NEGATIV, TRIGGER LEVEL 238 mV an X124 anschliessen.

- Um das Einschwingverhalten der Synthese richtig zu messen muß eine Flankendemodulation vorgenommen werden. Die RF-Frequenz der Synthesebaugruppe wird zur Vorbereitung auf 1040 MHz eingestellt. Dann wird im FREE RUN Betrieb des Analysators die Center-Frequenz des Spektrumanalysators in 100 Hz Schritten von 1040 MHz ausgehend verkleinert, bis der gemessene Wert auf 0 dBm liegt. Nach Umstellen der Synthese auf RF 520 MHz und des Analysators auf Trigger External erfolgt nun der Frequenzsprung auf 1040 MHz. Die Einstellung am Spektrumanalysator entspricht einem Skalierungsfaktor von ca. 120 Hz/dB.
- 50 ms nach erfolgtem Baugruppenstrobe (Triggersignal) darf sich die Spannung nur noch um maximal ± 100 Hz (ca. 0.85 dB) ändern. Es ergibt sich typisch ein Spannungsverlauf wie in Abbildung 3.

Abbildung 3

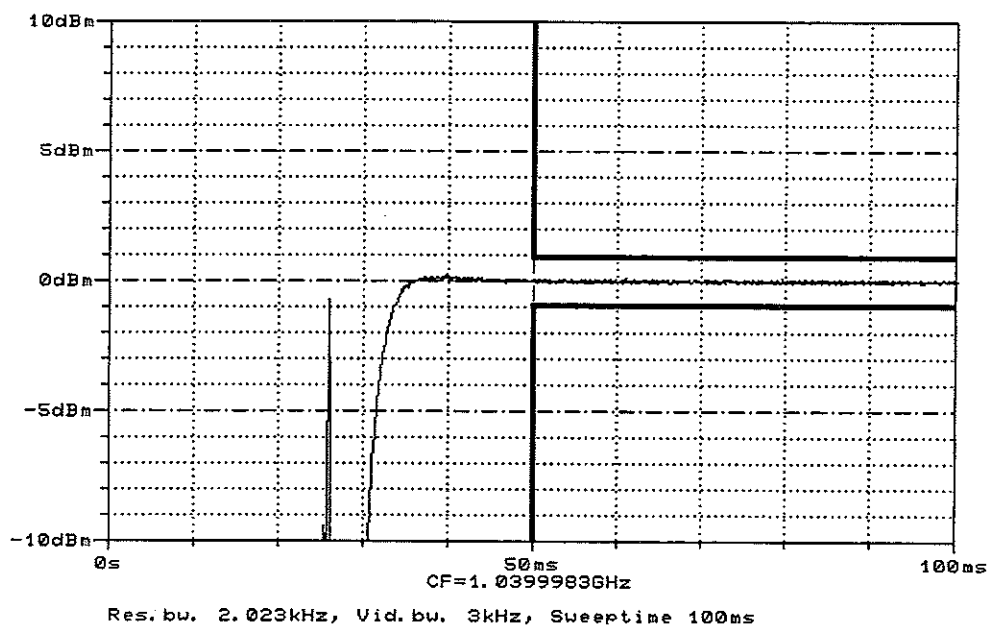

7.4.12 Endprüfungen Synthese

Das Durchführen der folgenden Endprüfungen sollte erfolgen, wenn zuvor Messungen oder eine Fehlerbehebung an der Baugruppe stattgefunden hat. Es müssen nun der löt- und bauteilseitige Deckel aufgeschraubt sein. Die Baugruppe befindet sich noch auf dem Prüfadapter.

7.4.12.1 Störhub Synthesizer

- Modulationsanalysator an X 124 anschliessen. Störhub mit Bewertungsfiler 20 Hz...23 kHz und CCITT bei folgenden Frequenzen (in MHz) prüfen:
520, 580, 640, 710, 779, 780, 840, 900, 970, 1040 MHz
- Störhub < 16 Hz_{rms} (20 Hz...23 kHz)
Störhub < 8 Hz_{rms} (CCITT)

7.4.12.2 Störhub 640 MHz Oszillator

- Modulationsanalysator an X125 anschließen. Störhub mit Bewertungsfilter 20 Hz...23 kHz und CCITT prüfen.
- Einstellungen: **RF 50 MHz**
 FM OFF
- _ Störhub < 4 Hz_{rms} (20 Hz...23 kHz)
 Störhub < 2 Hz_{rms} (CCITT)

7.4.12.3 Nebenwellen Synthesizer

- Spektrumanalysator mit Einstellung CF=FREQUENCY, SPAN 50 kHz, RES BW 300 Hz, VIDEO BW 30 Hz, REF LEVEL 15 dBm an X124 anschließen. Den Nebenwellenabstand bei den folgenden Frequenzen (in MHz) messen:
520.02, 544.02, 544.08, 640.005, 960.026666, 992.02, 1024.08 MHz
- _ Der Nebenwellenabstand ≥ 5 kHz neben dem Träger muß ≥ 70 dBc sein.

7.4.12.4 FM-DC Mittenfrequenzkalibrierung

- Einstellungen: **RF 1000 MHz**
 FM EXT DC 10 MHz
- Netzgerät (± 1 V) an Buchse FM/ ϕ M EXT anschließen (die eingestellte DC-Spannung muß hinreichend rausch- und brummfrei sein!).
- Modulationsanalysator mit Frequenzzähler an X124 anschließen.
- _ Spannung am Netzgerät auf 0 mV oder Eingangsbuchse FM/ ϕ M EXT kurzschließen.
- _ FM-DC Nulling Intern mit **SPEC 55** durchführen. Der Frequenzfehler muß < 10 kHz sein. Die Spannung von -1...+1 V variieren und dabei den Störhub messen, er muß < 1 kHz_{rms} (Bewertungsbandbreite 300 Hz...23 kHz) sein. Die Ausgangsfrequenz variiert von 990...1010 MHz.

7.4.13 Tabellen und Schnittstellen

7.4.13.1 Liste der Diagnosemeßpunkte

Zur Überwachung der wichtigen Regelspannungen und Pegel wird ein Diagnosemultiplexer (74HC4051) eingesetzt.
Zur Kompensation von Offsetspannungen kann das Potential der Baugruppenmasse gemessen werden (Diagnosepunkt 9).

	Diagnosepunkt	Meßpunkt	Min. V	MAX. V	Teilungsfaktor
9	R146	Referenz, 10 K Ω	-50 m	50 m	1
10	D-+10REF	10 V, Referenzspannung	9.9	10.1	3
11	D-PLL-VTCXO	Regelspannung VTCXO 10 MHz	0.3	4.7	3
12	D-PLL-640	Regelspannung VCO 640 MHz	4	17	5
13	D-REF640	Ausgangspegel LO, 640 MHz Pegel abgeschaltet	0.1 <0.05	0.6	1
14	D-FSYN	Ausgangspegel FSYN 65...1040 MHz	0.6	1	0.08
15	D-PLL-FSYN	Regelspannung VCO's FSYN	1.75	21.5	5
6	D-FM-KAL	Aussteuerung am PD, 1 kHz	0	50 m	3

7.4.13.2 Digitale Schnittstelle

Gemäß Gerätestandard verfügt die Baugruppe YSYN über eine serielle Schnittstelle. Mit Strobel werden die Daten für die HC4094-Latches bzw. die seriellen D/A - Wandler übernommen. Mit Strobe2 erfolgt die Übernahme der Daten am FRACSYN.

Polarität Clock: aktive Taktflanke L-->H
 Polarität Strobel: aktive Taktflanke L-->H
 Polarität Strobe2: aktive Taktflanke H-->L

Datenübertragung mit Strobel (HF1STB):
 Hubeinstellung für FM und PHIM, RF abhängige Hubkorrektur, Wahl der RF-Ausgangsteiler, Diagnose, Betriebsarten.
 Die Daten auf Strobel für die seriellen D/A-Wandler sind von aussen nicht zugänglich und werden daher nicht aufgeführt.

Datenübertragung mit Strobe2 (HF2STB):
 Frequenzinformation, Informationen für den Wobbelbetrieb und den Offsetaddierer.
 Die Daten auf Strobe 2 sind für den Baustein FRACSYN bestimmt. Sie sind von aussen nicht zugänglich und werden daher nicht aufgeführt.

Latch	Pin	Bezeichnung	Funktion		
D585	11	T2	Ausgangsteiler 4	0=Ein	1=Aus
	12	T1	Ausgangsteiler 2	0=Ein	1=Aus
	13	S6	Ausgang Teilerpfad 4,8	0=Aus	1=Ein
	14	S5	Eingang Teilerpfad 4	0=Aus	1=Ein
	7	S4	Pfad Kettenschaltung	0=Aus	1=Ein
	6	S3	Ausgang Teilerpfad 2	0=Aus	1=Ein
	5	S2	Eingang Teilerpfad 2,8	0=Aus	1=Ein
	4	S1	keine Teilung	0=Aus	1=Ein
D855	11	OSZ2	Oszillator 750...1040 MHz	0=Aus	1=Ein
	12	OSZ1	Oszillator 520...750 MHz	0=Aus	1=Ein
	13	EXTAC/DC	AC-DC-Umschaltung bei FM-EXT	0=FMAC	1=FMDC
	14	FMINT	Modulationsquelle INT	0=Aus	1=Ein
	7	FMEXT	Modulationsquelle EXT	0=Aus	1=Ein
	6	DEVCOARSE2			MSB
	5	DEVCOARSE1	Hubteiler Grob		
4	DEVCOARSE0	in 12 dB Schritten		LSB	
D670	11	PLL-GAIN2	Einstellung (0...7)		MSB
	12	PLL-GAIN1	Open-Loop-Gain		
	13	PLL-GAIN0	für HF-Regelschleife		LSB
	14	FM/φM	Differenzierer bei PM	0=FM	1=φM
	7	FMDIAOFF	Abschalten des FM-Detektors	0=Ein	1=Aus
	6	RESET-FRAC	Masterreset FRACSYN		1=aktiv
	5	S_FM_DIA	Reset Gleichrichter 1 kHz	0=Messen	1=Entl.
	4	S_DSIG	Sigma-Delta-Wandler	0=Aus	1=Ein

	Latch	Pin	Bezeichnung	Funktion	
D665	11	AD15	Einstellung Hubwertigkeit am A/D-Eingang FRACSYN Darstellung im Zweier- komplement		MSB
	12	AD14			
	13	AD13			
	14	AD12			
	7	AD11			
	6	AD10			
	5	AD9			
	4	AD8			
D660	11	AD7			
	12	AD6			
	13	AD5			
	14	AD4			
	7	AD3			
	6	AD2			
	5	AD1			
	4	AD0	LSB		
D110	11	MODOFF	Modulation Ein/Aus	0=Ein	1=Aus (CW)
	12	S-REF640	640 MHz Ausgangsstufe	0=Aus	1=Ein
	13	OPTREF	Umschaltung Standard/ Options-Referenz	0=Standard	1=Option
	14	INT/EXT	Umschaltung Interne/ Externe Referenz	0=Extern	1=Intern bzw.Option
	7	DIAGENA	Diagnose Ein/Aus	0=Aus	1=Ein
	6	DMUX2	Diagnosemultiplexer 0...7		MSB
	5	DMUX1			
	4	DMUX0		LSB	

7.4.13.3 Arbeitspunkte und Pegel von HF-Verstärkern

Eine qualitative Prüfung der HF-Wege ist nur mit einem HF-Tastkopf am Spektrumanalysator möglich. Dabei muß vor allem auf eine kurze niederohmige Masseverbindung geachtet werden. Der Vorwiderstand des HF-Tastkopfes sollte mindestens 1 k Ω betragen.

Die angegebenen Werte für die DC-Arbeitspunkte sowie für die HF-Pegel sind als typische Werte zu verstehen.

Verstärker	Arbeitspunkt	HF-Pegel, Frequenz	Bemerkung
V205	Pin2 Pin1	2.5 V 1.8 V	RF EXT AC 6 dBm, 10 MHz
V210	Pin2 Pin3	0.7 V 2.1 V	HCT, 10 MHz RF EXT AC
V215	Pin2 Pin3	0.7 V 2.6 V	RF EXT AC 12 dBm, 10 MHz
V216	Pin2 Pin3	3.1 V	RF EXT AC 10 MHz, 0 dBm an EXTREF HCT, 10 MHz 10 MHz, 0 dBm an EXTREF
V305	Pin3 Pin2,4	- 7.3 V - 7.7 V	8 dBm, 640 MHz
N300	Pin1 Pin3	4.6 V	- 3 dBm, 640 MHz 7 dBm, 640 MHz
V330	Pin1 Pin2 Pin3 Pin4	2 V 7.1 V 1.75 V 0.55 V	RF 50 MHz 14 dBm, 640 MHz X125 mit 50 Ω abschliessen 5.5 dBm, 640 MHz
V370	Pin2 Pin3	0.6 V 2.2 V	HCT, 10 MHz
V404	Pin3 Pin2,4	-5.8 V -6.1 V	RF 520 MHz 11 dBm, 520 MHz
V434	Pin3 Pin2,4	-5.8 V -6.1 V	RF 780 MHz 7 dBm, 780 MHz 9.5 dBm, 780 MHz
N490	Pin1 Pin3	4.6 V	- 5 dBm, 1000 MHz RF 1000 MHz 3 dBm, 1000 MHz
N500	Pin1 Pin3	4.7 V	- 2 dBm, 1000 MHz RF 1000 MHz 2 dBm, 1000 MHz
N510	Pin1 Pin3	4.4 V	- 6 dBm, 500 MHz RF 500 MHz 2 dBm, 500 MHz X124 mit 50 Ω abschliessen
N520	Pin1 Pin3	4.6 V	- 7 dBm, 250 MHz RF 250 MHz 4 dBm, 250 MHz X124 mit 50 Ω abschliessen
N560	Pin1 Pin3	4.8 V	2 dBm, 1000 MHz RF 1000 MHz 9 dBm, 1000 MHz X124 mit 50 Ω abschliessen
N600	Pin1 Pin3	4.6 V	- 7 dBm, 1000 MHz RF 1000 MHz 2 dBm, 1000 MHz
N610	Pin1 Pin3	4.7 V	- 7.5 dBm, 1000 MHz RF 1000 MHz 0 dBm, 1000 MHz
V600	Pin2 Pin3	0.75 V 0.95 V	RF 1000 MHz 10 dBm, 62.5 MHz

7.5

Zerlegung und Zusammenbau

Um die Baugruppe YSYN ausbauen zu können, ist nur die Unterseite des Gerätes zu öffnen. Zunächst wird die Rechnerbaugruppe ausgebaut. Dazu werden die beiden seitlichen Schrauben geöffnet und das Kabel für den IEC-Bus, das zur Rückwanne führt, entfernt. Die Rechnerbaugruppe kann nun herausgenommen werden, die Kabel zur Tastatur/Anzeige sowie zum Motherboard bleiben angesteckt. Nach dem Lösen der beiden seitlichen Schrauben der Synthesebaugruppe können die drei, bzw. vier (bei vorhandenem Optionsquarz) HF-Verbindungen an der Baugruppe abgezogen bzw. aufgeschraubt werden. Die Baugruppe YSYN wird nun seitlich nach hinten aus ihrem Steckplatz entnommen.

Über das sich im Servicekit befindende Flachbandkabel kann die Synthesebaugruppe nun wieder mit dem Motherboard verbunden werden. Die Buchsen X127 und X128 werden ebenfalls über die sich im Servicekit befindlichen koaxialen Kabel mit den entsprechenden Anschlüssen EXTREF sowie, falls vorhanden, mit dem Optionsoszillator verbunden.

Die Schirmdeckel sind auf herkömmliche Weise verschraubt. Beim Betrieb mit geöffnetem Schirmdeckel ist darauf zu achten, daß die Resonatorhöhlen E und F auf beiden Seiten mit geeigneten Prüfdeckeln verschlossen werden.

7.6

Externe Schnittstellen

Die Angaben für den Stromverbrauch der jeweiligen Versorgungsspannung bezieht sich auf den Zustand der Baugruppe nach einem **PRESET**.

Pin	Name	Ein/Ausgang	Herkunft/Ziel	Wertebereich	Signalbeschreibung
X1A.4	EXT1	Eingang	Fronteinheit	1V _s	Modulationsspannung
X1A.6	INT1	Eingang	Rechner X3.32	1V _s	Modulationsspannung
X1A.8	FMKOMPLO	Ausgang	Rechner X3.23	HCMOS-Pegel	Pegelüberwachung EXT
X1A.9	FMKOMPFI	Ausgang	Rechner X3.24	HCMOS-Pegel	Pegelüberwachung EXT
X1A.10	OPTUNE	Ausgang	Netzteil X21.24	0...10V	Abstimmspannung für optionale Referenz (SM-B1)
X1A.12	SERCLK	Eingang	Rechner X3.2	HCMOS-Pegel	Clock für Datenübertragung
X1A.14	SERDAT	Eingang	Rechner X3.4	HCMOS-Pegel	Serielle Daten
X1A.15	HF1STB	Eingang	Rechner X3.14	HCMOS-Pegel	Strobe1
X1A.16	HF2STB	Eingang	Rechner X3.15	HCMOS-Pegel	Strobe2
X1A.17	HFINT	Ausgang	Rechner X3.20	TTL-Pegel	Interrupt Regelschleifen
X1A.19	DIAG-5V	Ausgang	Rechner X3.6	0...5V	Diagnose
X1A.22	VA24-P	Eingang	Netzteil X21.22	23.0...25.0 V 12 ± 5 mA	Versorgungsspannung analog
X1A.24	VA15-P	Eingang	Netzteil X21.13	14.4...15.6 V 110 ± 25 mA	Versorgungsspannung analog
X1A.25	VA15-P	Eingang	Netzteil X21.13	14.4...15.6 V 110 ± 25 mA	Versorgungsspannung analog
X1A.26	VA7.5-P	Eingang	Netzteil X21.8	7.2...7.8 V 650 ± 100 mA	Versorgungsspannung analog
X1A.28	VA-5P	Eingang	Netzteil X21.5	4.9...5.3 V 35 ± 10 mA	Versorgungsspannung digital
X1A.30	VA15-N	Eingang	Netzteil X21.19	-15.6...-14.4 V -195 ± 35 mA	Versorgungsspannung analog
X128	OPT10	Eingang	Referenzosz.	7.5 ± 1.5 dBm	10 MHz ± 5 ppm
X127	EXTREF	bidir.	Rückwand	5/10 MHz ± 3ppm -13...13 dBm	Eingang Referenz
X124	FSYN	Ausgang	Ausgangsteil	10MHz, 6...10 dBm 7...14 dBm	Ausgang Referenz Synthese Freq 65..1040 MHz
X125	REF640	Ausgang	Ausgangsteil	8...12 dBm	Referenz 640 MHz



ROHDE & SCHWARZ

SERVICE INSTRUCTIONS

Synthesizer

1062.6409.01

Contents

7 Testing and Repair of the Module.....	5
7.1 Function Description.....	5
7.1.1 Reference Frequencies.....	5
7.1.1.1 Internal Reference 10 MHz.....	5
7.1.1.2 External Reference 5 or 10 MHz.....	5
7.1.1.3 640-MHz Oscillator including PLL.....	6
7.1.2 Synthesizer 65 to 1040 MHz.....	6
7.1.2.1 Oscillators 520 to 1040 MHz.....	6
7.1.2.2 Output Dividers.....	6
7.1.2.3 Fractional-N-Divider and PLL.....	7
7.1.3 FM/ ϕ M Modulation.....	7
7.1.3.1 Function Principle.....	7
7.1.3.2 FM/ ϕ M-Deviation Divider.....	7
7.1.3.3 Sigma-Delta Converter and FM-DC Control.....	8
7.1.4 Calibration Routines.....	8
7.1.4.1 VCO Calibration.....	8
7.1.4.2 FM-Calibration.....	9
7.2 Test Instruments and Utilities.....	9
7.3 Troubleshooting.....	9
7.3.1 Synchronization Errors.....	9
7.3.2 Error with CW-Operation.....	10
7.3.3 Error with FM-/ ϕ M-Modulation.....	11
7.3.4 Calibrations.....	12
7.4 Testing and Adjustment.....	12
7.4.1 Data Transmission and Power Supply.....	12
7.4.2 Reference Frequency Generation.....	13
7.4.2.1 Internal Reference.....	13
7.4.2.2 External Reference.....	13
7.4.3 640-MHz Reference.....	13
7.4.3.1 Oscillator 640 MHz and PLL.....	14
7.4.3.2 Output Amplifier 640 MHz.....	14
7.4.4 Output Oscillators.....	15
7.4.5 PLL of the Output Oscillators.....	15
7.4.5.1 Checking the Dividers in the PLL.....	15
7.4.5.2 Checking the Phase Detector.....	16
7.4.5.3 Checking the Loop Integrator.....	17
7.4.5.4 Checking the Closed PLL.....	18
7.4.6 Output Stage with Dividers.....	18
7.4.7 Testing the Deviation Divider.....	18

7.4.8	EXT Monitoring.....	19
7.4.9	Sigma-Delta Converter Including FM-DC Control.....	19
7.4.10	FM-Deviation Setting.....	20
7.4.10.1	Checking the FM-Diagnostic Detector.....	20
7.4.10.2	Adjustment of FM-deviation.....	20
7.4.10.3	Checking FM-Calibration.....	21
7.4.11	Transient Response of Synthesis.....	21
7.4.12	Final Tests of Synthesis.....	22
7.4.12.1	Residual FM of Synthesizer.....	22
7.4.12.2	Residual FM 640-MHz Oscillator.....	22
7.4.12.3	Spuriae of Synthesizer.....	23
7.4.12.4	FM-DC Center Frequency Calibration.....	23
7.4.13	Tables and Interfaces.....	23
7.4.13.1	List of Diagnostic Test Points.....	23
7.4.13.2	Digital Interface.....	23
7.4.13.3	Operating Points and Levels of RF Amplifiers.....	26
7.5	Disassembly and Assembly.....	27
7.6	External Interfaces.....	27

Parts list
Coordinates list
Circuit diagram
Component location plan

In instruments without fitted option SMY-B40, this module has the variant VAR 02.

In instruments with fitted option SMY-B40, this module has the variant VAR 04.

7.1 Function Description

Module YSYN contains a synthesizer which can be FM/ ϕ M-modulated from 65 to 1040 MHz, the deviation divider for FM/ ϕ M as well as the reference frequency generation consisting of a 10 MHz VTCXO as well as a 640 MHz oscillator as LO for the mixer range of the output stage.

7.1.1 Reference Frequencies

7.1.1.1 Internal Reference 10 MHz

A 10-MHz VTCXO (N200) is used as a standard reference. An emitter follower including level converter (V205 and V210) amplifies the output signal to TTL level (test point P201). At the same time, the signal of the option reference is fed here (input X128, OPT10). In this operating mode, the standard oscillator is switched off using switching transistor V200 and the path for the option reference bypassed via diode V235. The divider stage (D205-A) generates the 2-MHz reference frequency for the PLL of the output oscillators and the Sigma-Delta converter as well as the 1MHz reference frequency for the phase detector of the reference PLL (test point P202). The 10-MHz signal which has been coupled out via D200 serves as a reference frequency for the PLL of the 640-MHz oscillator.

In this operating mode, either the standard reference or, if fitted, the option reference is applied at output X127 (EXTREF). Exact frequency setting is effected using a 12-Bit D/A-converter (D220) which is provided by a 10-Volt reference voltage (+10REF) (tuning voltage UINT or OPTTUNE).

7.1.1.2 External Reference 5 or 10 MHz

In the External Reference operating mode, 5 or 10 MHz can be fed with a tolerance of ± 3 ppm at X127 (EXT REF). A diode circuit (V220) generates a harmonics spectrum, a resonance amplifier (V215) filters out the 10-MHz signal and the following level converter (V216) amplifies it to TTL level (test point P204). After dividing the frequency by 10 (D205-B), the signal is compared to the down-divided frequency of the TCXO in phase detector D210. The standard reference oscillator is synchronized with the external reference in a PLL with a bandwidth of 2 Hz. The tuning voltage of the PLL can be remeasured at P203 (U-PLL-VTCXO). If there is an optional reference oscillator (SM-B1), its level is cut off in the External Reference operating mode. The tuning voltage of the oscillator is monitored in both operating modes using the window comparator N100 via a buffer (N220-C).

7.1.1.3 640-MHz Oscillator including PLL

The 640-MHz oscillator is designed using a ceramic resonator (X300) which is fine-tuned by means of a tuning diode (V300). Transistor stage V305 uses its negative impedance to amplify the resonant circuit. The oscillator signal is coupled out at the emitter via a buffer amplifier (N300). Via an resistive power divider, the signal is splitted up to the output amplifier (V330) as well as the frequency divider (B360) which divides the signal for the PLL to the 10 MHz-reference frequency.

The output amplifier with a "Dual Gate MESFET" (V330) amplifies the oscillator signal to approx. 10 dBm (X125, REF640). If the mixer path in the output section is not active, the output level can be reduced by more than 40 dB via gate2 of the output amplifier by means of the switching transistors (V340, V345) (control signal S-Ref 640).

The signal generated via the fixed divider by 64 is converted to TTL level (test point 354) using transistor stage V370 and is compared with the 10-MHz reference frequency at the phase detector (D255). The output voltage of the PI-controller (N250) tunes the oscillator, the bandwidth of the PLL is approx. 300 Hz.

The level of the 640-MHz output amplifier is measured by a diagnostic rectifier (V347). The control voltage of the PLL is monitored by a window comparator (N105).

7.1.2 Synthesizer 65 to 1040 MHz

7.1.2.1 Oscillators 520 to 1040 MHz

Two oscillators with a tuning range of 260 MHz each generate the frequency of the basic octave. A transistor with a negative impedance at its basis (V404 and V434) amplifies the series resonant circuit consisting of a porcelain capacitor (C402 and C432), a printed inductor and two times two tuning diode connected in parallel (V400-V403 and V430-V433). Due to the small tolerances of the elements determining the resonant circuit, a frequency adjustment of the oscillators is not necessary. A power source (V406 and V436) whose supply voltage can be switched on and off via a transistor stage stabilizes the operating point of the oscillator via the tuning range. Depending on the active oscillator, the output signal is supplied to the buffer stage N490 via a PIN switch (V490 and V492). An resistiv power divider branches the oscillator signal to the output dividers as well as to the fractional-N-divider of the PLL.

7.1.2.2 Output Dividers

The output frequencies of 65 to 520 MHz are implemented by means of frequency division by two, four and eight. A divider by 2 (D510) and a divider by 4 (D520) are used. By forming an iterative network of the two dividers, division factor eight is achieved. The individual signal paths are switched via PIN switches (S1 to S6). The divider components are switched on and off via the supply voltage using transistors V510 and V520. Output amplifier N560 increases the level to approx. 8 to 12 dBm. This output level is monitored via the diagnostic rectifier V555.

7.1.2.3 Fractional-N-Divider and PLL

The output oscillators are locked to a reference frequency of 2 MHz in a PLL with a fractional divider. This component of the circuit is integrated in gate-array FRACSYN (D65). The two MMIC amplifiers N600 and N610 decouple the divider circuit from the oscillators. The two frequency dividers (D620 and D630) divide the oscillator frequency by 16 and thus provide input frequencies of 32.5 to 65 MHz for the FRACSYN executing the actual fractional division (test point P600). Component FRACSYN calculates the new division factor for every reference period from the division factor programmed via a serial interface as well as the deviation set. Its output clock CKO of 2 MHz is synchronized with the input clock of the FRACSYN using synchronization flip-flop D655. The synchronized 2-MHz signal is supplied to phase detector D700 from there.

The UP/DOWN output signals of the phase detector obtained from comparing the phase with the 2-MHz reference frequency (2REF) are added in differential amplifier N710 (test point P700). The gain of the following PI-controller (N720) can be set in 8 stages using an analog multiplexer (D720) to compensate for gain variations in the PLL caused by the different division factor as well as the different VCO slope. A transistor output stage (V750 and V755) with diode switchover of the PLL bandwidth (V765 to 768) accelerates the settling process of the PLL in the case of a frequency change.

The output voltage of the PI-controller (A-PI-SYN) is monitored by a window comparator (N110). The tuning voltage of the oscillators can be measured via a diagnostic point.

7.1.3 FM/ϕM Modulation

7.1.3.1 Function Principle

The use of a fractional divider with a digital modulation input permits implementing a relatively simple and yet precise FM AC/DC and ϕM circuit.

The modulation is transmitted via two paths with different frequency responses. In the first path, the division factor and thus the instantaneous center frequency is directly modulated in the case of FM after the A/D conversion using a Sigma-Delta converter. This part has the lowpass function for the wanted transmission of a PLL, at the same time the PLL is a lowpass filter for the quantization noise of the A/D converter here. In the second path, the oscillator is modulated directly, this part has the highpass function for the unwanted transmission of a PLL. With equal sensitivity and delay in both paths, the frequency response is flat with a constant group delay.

ϕM is generated by differentiating the modulation voltage. The cut-off frequency of the differentiator is approx. 40 kHz. A DC-modulation is thus not possible with ϕM. The transmission functions are the same as with FM.

7.1.3.2 FM/ϕM-Deviation Divider

The two inputs INT1 and EXT1 are available for feeding the modulation signals. The external modulation input has a high-impedance input amplifier (N800) with switchable AC/DC coupling (D820). The input impedance can be selected via jumper X80. It is 100 kΩ or 600 Ω.

The desired modulation signal is selected via switch D800. A single-tone modulation (external or internal) and two-tone modulation (external and internal) is possible. Amplifiers N845 and N850 amplify the input signal from $1V_s$ to $6V_s$. The signal for the Sigma-Delta converter is tapped in between via amplifier N850. The current flowing here is always constant. A multiplying 12-bit D/A converter (D840) is used to fine-adjust the deviation in the control path for the modulation via the oscillators. The following operational amplifier performs an impedance conversion. For the coarse adjustment of the deviation at the oscillator, an attenuator forming an iterative network with steps of 12 dB is used (divides by 1 to 4096). The taps are switched by analog multiplexer D960. With modulation switched off, the oscillator input is connected to ground via a FET (N960) in order to minimize thermal noise.

The deviation values for the modulation of the division factor via the Sigma-Delta converter is coarsely adjusted internally in the FRACSYN and finely adjusted via the ADWE inputs (shift registers D660 and D665) with a resolution of 16 bits.

For ϕM , a differentiating circuit is inserted into the common branch (reed relay K910). Otherwise, the transmission paths are identical to FM.

The level at the EXT input is monitored by the window comparator circuit using N860 and D870. In the case of a deviation from the rated level of 1 to 3 %, interrupt FMKOMPFI (voltage fed is too high) or FMKOMPLO (voltage fed is too low) is triggered depending on the direction.

7.1.3.3 Sigma-Delta Converter and FM-DC Control

A Sigma-Delta converter of 3rd order (N940, N950, N960, D950 and D965) converting the analog modulation signal into a digital signal is used to modulate the division factor. The variable average of the 1-bit output signal corresponds to the analog input quantity. The quantization noise caused is filtered by the lowpass function of the PLL. A delay equalizing circuit at the input of the converter ensures an equal group delay in both modulation paths.

As all offset voltages lead to a shift of the center frequency also with AC operation, they are compensated by an average control. In the case of FM-DC, the control is to be clamped in order not to level out the DC modulation voltage. This component of the circuit is also located in gate array FRACSYN.

7.1.4 Calibration Routines

7.1.4.1 VCO Calibration

In steps of 5 MHz, a table of the respective tuning voltages of the oscillators is created. The respective oscillator slope $k_o(f)$ can be calculated from these values determined via diagnosis with a linear interpolation of the intermediate values. It is required in order to determine the necessary PLL-GAIN which is used to compensate the gain fluctuations in the closed loop. The slope values determined are also required as starting values to calculate the rate of rise of deviation for FM calibration.

7.1.4.2 FM-Calibration

For the calibration table of the rate of rise of deviation, a diagnostic detector (N780, V781, C782) measures the differential deviation in the closed loop at a modulation frequency of 1 kHz. In an adjustment routine, the control elements of the FM/φM deviation divider are varied until the differential deviation measured is minimal. The modulation slope of the oscillator at the respective frequency is calculated from the setting values thus achieved. This table is also created in steps of 5 MHz.

7.2 Test Instruments and Utilities

- RF-spectrum analyzer (FSA)
- RF-signal generator (SMGU, SME)
- Function generator $f \geq 2$ MHz, (AFGU, AFS)
- Oscilloscope $f > 250$ MHz
- AC/DC voltmeter (URE3)
- Modulation analyzer with distortion meter (FMA, FMB)

7.3 Troubleshooting

For fault diagnosis, the test program included in service kit SMY-Z1, which offers extensive possibilities of diagnosis, is suitable as well.

7.3.1 Synchronization Errors

Error messages Error 1 to Error 3 are an OR-operation of the error controls of the phase locked loops for the 10-MHz TCXO, the 640-MHz oscillator as well as the PLL of the output oscillators. If there is an error at the 10-MHz PLL, this can also cause the other closed loops to be locked out. The relevant diagnostic point can be used to check which of the three phase locked loops is out of tolerance.

**Error message "Error 1"
10-MHz reference loop out of
synchronization**

Check whether the correct frequency with a sufficient level is fed in the external reference operating mode.

Check the external reference according to 7.4.2.2

Check window comparator N100

**Error message "Error 2"
640-MHz loop out of
synchronization**

Check whether 10-MHz reference frequency is applied to phase detector D255.11.

Check the 640-MHz oscillator and the PLL according to 7.4.3.1

Check window comparator N105

**Error message "Error 3"
Main oscillator loop out of
synchronization**

Check output oscillators according
to 7.4.4

Measure whether 2-MHz reference
signal is applied to phase
detector D700.3. Check PLL of the
output oscillators according to
7.4.5

Check window comparator N110

7.3.2 Error with CW-Operation

**No output level or output
level too small at X124**

Check output oscillators according
to 7.4.4

Check output divider using
dividers according to 7.4.6

Check the operating points or the
RF levels of the amplifiers in the
path (table 7.4.13.3)

**Residual FM too high (no
spuriae)**

Execute calibration routine VCO
using **SPEC 41**

Check oscillators according to
7.4.4, also their operating points
according to table 7.4.13.3
Measure residual FM of the
oscillators, the DC voltage fed
must be sufficiently free of hum
and noise

Check PLL of the output
oscillators according to 7.4.5.1-
7.4.5.3, check supply voltages of
FRACSYN and phase detector (7.4.1)

**Spuriae > -70 dBc for offset
frequencies > 5 kHz to carrier**

Execute calibration routine VCO
using **SPEC 41**

Check phase offset of the phase
detector, DC-voltage at C701
should be 1.65 V

Check supply voltage FRACSYN and
phase detector (7.4.1)

7.3.3**Error with FM-/φM-Modulation**

Deviation error with FM or φM; Stereo crosstalk out of tolerance	Execute calibration routine FM using SPEC 43
Substantial modulation distortions with maximal deviation	Check the deviation divider according to 7.4.7 Check deviation setting according to 7.4.9
FM-distortion factor too high	Execute calibration routine FM using SPEC 43 Check deviation divider according to 7.4.7, check distortion factor of the modulation signal at X84 Check FM calibration according to 7.4.10.3
No or false FM-modulation with modulation frequencies of less than 1 kHz	Check Sigma-Delta converter according to 7.4.9 Perform adjustment of FM deviation according to 7.4.10.2
No or false FM-modulation with modulation frequencies of more than 1 kHz	Execute calibration routine FM using SPEC 43 Check deviation divider acc. to 7.4.7
FM-frequency response too large	Check deviation divider acc. to 7.4.7 Measure frequency response also after coarse divider at D960.3 (FM deviation set > 3 MHz, RF > 520 MHz)
Center frequency error with FM-DC modulation, or FM-DC center frequency calibration (special function 55 not performed correctly)	Check Sigma-Delta converter and FM-DC control according to 7.4.9
No or false φM-modulation	Check whether an FM modulation set equivalently is correct, otherwise error with PM differentiator (highpass filter with C913 and R848, is checked in 7.4.7) (equivalent FM = PM set * AF frequency fed)

7.3.4 Calibrations

**Error message "Error 15"
Calibration VCO faulty**

Check output oscillators according to 7.4.4

Check PLL of the output oscillators according to 7.4.5

Check transient response of the synthesis according to 7.4.11

**Error message "Error 15"
Calibration FM faulty**

Check the FM diagnostic detector acc. to 7.4.10.1, the offset of the diagnostic detector (measure test point 15 via diagnosis, do not feed an AF frequency) must be less than 50 mV.

Check the deviation divider according to 7.4.7

Check Sigma-Delta converter according to 7.4.9

Check delay equalization at the Sigma-Delta converter input

7.4 Testing and Adjustment

All measured values without tolerances stated are to be understood as guide values. Voltage values without further designation are DC voltages.

If the module is operated with the cover opened, the two oscillator chambers must be closed on the component and solder side by means of test covers.

The SMY has to be brought to a defined initial status by means of PRESET prior to all tests.

7.4.1 Data Transmission and Power Supply

(Cf. circuit diagram sheet 9)

According to the device standard, the module is controlled via a serial interface. Data transmission is effected on two different subaddresses. The data are accepted by the two module strobes HF1STB and HF2STB. The settings and the pertaining data are to be found in Section 'Digital Interfaces'.

Current consumption can be checked by looping in an amperemeter instead of coils L1 to L5. The rated values can be found in Section 'External Interfaces'.

The most important reference or supply voltages are remeasured using the DC voltmeter.

Test point	Type of voltage	Voltage [V]
P20	10-V reference	+9.9 to +10.1
P21	Supply volt. 5 V analog	+5.1 to +5.4
D700_14	Supply volt. phase detector	4.6 to 5.0 V
D65_84	Supply volt. FRACSYN	5.1 to 5.5 V

7.4.2 Reference Frequency Generation

7.4.2.1 Internal Reference

(Cf. circuit diagram sheet 2)

The tuning voltage for the internal reference is read via the diagnosis for different D/A converter values (function D/A converter). A 10-MHz HCMOS signal must be visible on the oscilloscope (function level converter). Output level EXTREF can be measured using the spectrum analyzer.

- Connect oscilloscope with probe to P201
- Connect spectrum analyzer to EXTREF (rear of the instrument)

- Settings: **SPEC 111**
 RF INT/ON

_ Set the D/A converter values according to the table via special function 51 and check diagnostic voltage. The calibration values entered are accepted on pressing the ENTER key.

SPEC 51	Diagnostic voltage at test point 11
0	± 150 mV
4095	4.7 to 5.3 V
2048	2.3 to 2.7 V

- _ Check signal at P201: 10 MHz, HCMOS
- _ Measure output signal at spectrum analyzer: 10 MHz, 7.5 ± 2 dBm

7.4.2.2 External Reference

(Cf. circuit diagram sheet 2)

First the input of the external reference is tested using the multiplier connection.

- Connect signal generator 5 MHz to EXTREF (rear of the instr.).
- Connect oscilloscope with probe to P204.

- Settings: **RF EXT AC**

_ Check signal at P204: 10 MHz, HCMOS level for input levels from -13 to 13 dBm at input EXTREF.

Now the PLL and the pulling range of the VTCXO are checked. The control voltage is checked via the diagnosis.

- Settings: **SPEC 111**
- Feed frequency of the signal generator according to the table, level: 7 dBm.

_ Check diagnostic voltage according to the table.

Frequency at EXTREF	Diagnostic voltage test point 11
10 MHz	2.5 ± 0.5 V
9.999970 MHz	> 0.5 V
10.000030 MHz	< 4.5 V

7.4.3 640-MHz Reference

7.4.3.1 Oscillator 640 MHz and PLL

(Cf. circuit diagram sheet 2 and 3)

The function and the tuning range of the oscillator are checked.

- Withdraw jumper X20 and connect power supply unit (0 to 20 V) to X20.2 and X20.3 (ground).
- Connect spectrum analyzer to X125 with setting CF 640 MHz, SPAN 50 MHz and REF LEVEL 10 dBm.

• Settings: **RF 50 MHz**

- _ Vary tuning voltage from 0 to 20 V, the oscillator must oscillate without failures, secondary lines or high noise in the entire tuning range at 640 ± 20 MHz.
- _ Switchover tuning voltage between 2 and 18 V, the frequency change of the oscillator must be > 15 MHz and < 25 MHz.
- _ The tuning voltage for 640 MHz must be > 4 V and < 16 V.

- Remove power supply unit again and plug jumper X20 onto 1-2.

Tuning voltage is now measured via diagnosis with the PLL closed.

• Settings: **SPEC 112**

- _ Diagnostic voltage at test point 12: 10 ± 6 V

7.4.3.2 Output Amplifier 640 MHz

(Cf. circuit diagram sheet 3)

The output level is checked with the signal switched on or off.

- Connect spectrum analyzer with setting CF 640 MHz, SPAN 50 MHz, REF LEVEL 15 dBm to X125.

• Settings: **RF 50 MHz**
 SPEC 113

- Measure level 640 MHz at spectrum analyzer: 10 ± 2 dBm.
- _ Diagnostic voltage at test point 13: 100 to 400 mV.

The frequency of the SMY is set such that the LO amplifier is switched off.

• Settings: **RF 100 MHz**

- Measure level 640 MHz at the spectrum analyzer: < -30 dBm.

7.4.4 Output Oscillators

(Cf. circuit diagram sheets 4, 5 and 7)

The trim cover on the component and the solder side must absolutely be screwed onto the oscillator chambers.

The function of the two output oscillators and their tuning range are checked. The diagnostic voltage for the output level is checked as well.

- Connect spectrum analyzer with setting CF 780 MHz, SPAN 800 MHz, REF LEVEL 15 dBm to X124.
- Remove jumper X75 and connect power supply unit to X75.2 and X75.3 (ground).

_ The tuning voltage is varied for both oscillators between 0 and 22 V, the oscillator must oscillate in the entire tuning range without failures, secondary lines and high noise. At the lower and upper frequency limits of both oscillators, the tuning voltage must be in the tolerance window stated (cf. table). The output level at X124 must be between 7 and 14 dBm.

Setting	Oscillator	Min. freq.	Tun. volt.	Max. freq.	Tun. volt.
RF 600 MHz	1	520 MHz	1.75 to 4 V	780 MHz	16.5 to 19.5 V
RF 900 MHz	2	780 MHz	1.75 to 4 V	1040 MHz	16.5 to 19.5 V

With an output frequency of approx. 1040 MHz, diagnosis is tested as well.

Settings: **SPEC 114**

_ Diagnostic voltage at test point 14: 80 to 400 mV

- Remove power supply unit and plug jumper X75 on 1-2 again.

7.4.5 PLL of the Output Oscillators

In order to detect possible errors in a phase locked loop, it is useful to open it and to perform troubleshooting at the opened PLL. Jumper X75 remains removed during tests 7.4.5.1 - 7.4.5.3. To facilitate tracking of the output frequency set, a spectrum analyzer should be connected to X124.

7.4.5.1 Checking the Dividers in the PLL

(Cf. circuit diagram sheet 6)

The divider chain in the feedback of the PLL is checked first.

- Remove jumper X75 and connect power supply unit to X75.2 and X75.3 (ground).
- Set voltage at the power supply unit to approx. 16 V (oscillator 2 oscillates to approx. 1000 MHz)
- Connect oscilloscope including probe to P600.

• Settings: **RF 1000 MHz**

_ Check signal at P600: approx. 62.5 MHz, TTL level

- Connect oscilloscope including probe to P610.

_ Check signal at P610: approx. 2 MHz, HCMOS level

7.4.5.2 Checking the Phase Detector

(Cf. circuit diagram sheet 7)

When the phase detector is checked, first make sure that the reference frequency (signal 2REF) which is synchronized to is applied correctly.

- Settings: **RF 1000 MHz**
- _ Check signal at D700.3 using probe at oscilloscope: 2 MHz, HCMOS level
- Now connect oscilloscope including probe to P700.
- Slightly reduce voltage at the power supply unit at X75 such that the output frequency of oscillator2 is less than 1000 MHz.
- _ Falling saw-tooth voltage at P700 with the differential frequency of the two input signals, DC voltage at P700 is negative (approx. - 0.8 V)

Fig. 1

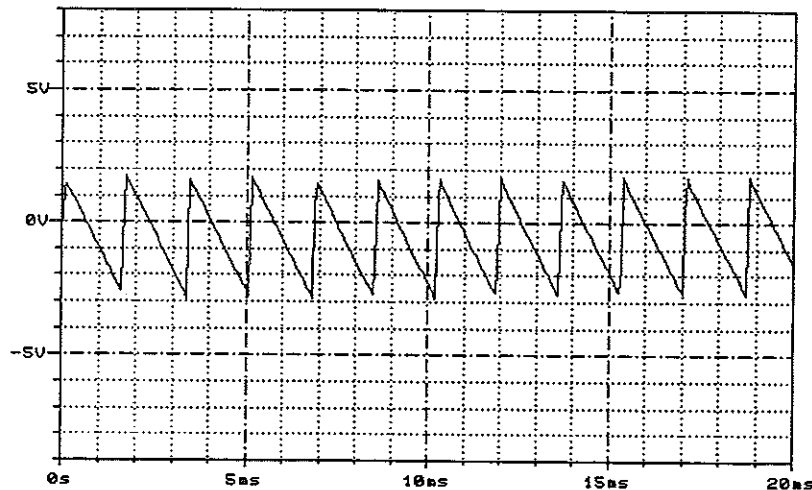

- Now slowly increase the voltage at power supply unit at X75 such that the output frequency of oscillator2 becomes more than 1000 MHz. The voltage at P700 is observed.
- _ Rising saw-tooth voltage at P700 with the differential frequency of the two input signals, DC voltage at P700 is positive (approx. 4 V)

Fig. 2

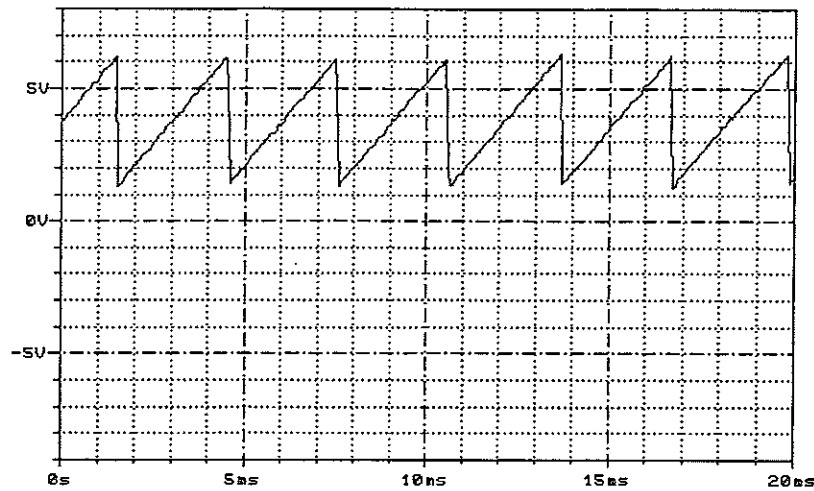

7.4.5.3 Checking the Loop Integrator

(Cf. circuit diagram sheet 7)

An exact test of the integral loop integrator with an opened loop is not possible. Thus only coarse functionality is checked.

- Connect oscilloscope including probe to P720.
- Settings: **RF 1000 MHz**

The procedure in the functionality test of the loop amplifier is identical to the test of the phase detector. The fed DC voltage at X75 is first reduced such that the oscillator oscillates below 1000 MHz. Now a negative input current flows into the integral controller, which increases its output voltage to approx. 21 to 24 V at P720. If the voltage at X75 is increased such that the oscillator now oscillates above 1000 MHz, a positive input current flows into the integral controller such that its output voltage decreases to approx. 0 V. If the differential frequency set is very low, an AC voltage with the corresponding differential frequency can be superimposed on the DC voltage at P720.

It is also recommended to check the voltage after the subsequent lowpass filter (voltage at X75.1). It must be identical to the voltage at P720.

- Remove power supply unit and plug jumper X75 on 1-2 again.

7.4.5.4 Checking the Closed PLL

(Cf. circuit diagram sheet 4, 6 and 7)

After plugging jumper X75, the PLL is closed.

- Settings: **RF FREQUENCY (acc. to table)**
SPEC 115
- Connect spectrum analyzer with setting CF=**FREQUENCY**, Span 100 kHz, Rev.lev. 15 dBm to X124.

_ The output signal is checked with the different RF settings. No secondary lines or high noise must be visible on the spectrum analyzer.

FREQUENCY	Diagnostic voltage test point 15
520 MHz	1.75 to 4 V
779.999999 MHz	16.5 to 19.5 V
780 MHz	1.75 to 4 V
1040 MHz	16.5 to 19.5 V

7.4.6 Output Stage with Dividers

(Cf. circuit diagram sheet 5)

Output dividers by 2, 4 and 8 are checked. The diagnostic voltage and the output level are checked as well. For this test it is necessary that the PLL and the output oscillators work perfectly and thus all frequencies of the ground octave from 520 to 1040 MHz can be set.

- Settings: **RF FREQUENCY (acc. to table)**
SPEC 114

_ Check the frequency set as well as the output level at the spectrum analyzer according to the table.
_ Voltage at test point 14 for all RF frequencies: 80 to 600 mV

FREQUENCY	Divider	Level at X124
1040 MHz	1	7 to 14 dBm
780 MHz	1	7 to 14 dBm
779 MHz	1	7 to 14 dBm
520 MHz	1	7 to 14 dBm
500 MHz	2	7 to 14 dBm
250 MHz	4	7 to 14 dBm
125 MHz	8	7 to 14 dBm

7.4.7 Testing the Deviation Divider

(Cf. circuit diagram sheet 8)

The modulation matrix for both channels, the AC/DC switchover for the external input, the differentiator for ϕM as well as the fine deviation divider are checked.

- Remove jumper X84.
- Feed modulation signal at input socket EXT at the front unit according to the table, remeasure the rated voltages at test points according to the table using AC/DC voltmeter.

- Settings: **RF 1000 MHz**

Setting	Signal at EXT	Signal at P840	Signal at X84.1
FM EXT DC 10 MHz	1 V	- 3.32 ± 0.1 V	- 6 to - 1.5 V (Reference value)
AF 1 kHz, FM INT 10 MHz	-	3.32 ± 0.1 Vs	- 6 to - 1.5 Vs (=Reference value)
FM EXT AC 10 MHz	2 MHz, 1 Vs	3.32 ± 0.2 Vs	DC < 40 mV Ref. value ± 3 dB
ΦM EXT 175 rad	20 kHz, 1 Vs	3.32 ± 0.1 Vs	DC < 40 mV Ref. value - 10 dB (± 1 dB)

Now the fine deviation dividers are checked

- Settings: **RF 1000 MHz**
 AF 1 kHz
 FM INT 0 Hz
 FM STEP 100 Hz

_ Vary the FM deviation at the front module from 0 Hz to 2.5 kHz in steps of 100 Hz using the rotary knob. The AF voltage at X84.1 must rise from 0 V to approx. 3.2 V_S in equal steps (approx. 0.13 V).

7.4.8 EXT Monitoring

(Cf. circuit diagram sheet 8)

- Connect AF generator, 1 kHz, level according to the table, to EXT.
- _ Check the function of level monitoring according to the table.

- Settings: **FM EXT AC 100 kHz**

Input voltage at EXT	Display
1 ± 0.005 Vs	-
1.03 ± 0.005 Vs	EXT-HIGH
0.97 ± 0.005 Vs	EXT-LOW

7.4.9 Sigma-Delta Converter Including FM-DC Control

(Cf. circuit diagram sheet 8)

The function of the Sigma-Delta converter as well as the FM-DC control in operating modes FM-AC and FM-DC is checked.

- Settings: **RF 1000 MHz**
- Connect DC voltage source (0 to 1V) to modulation input EXT.

Check the DC voltages stated using a DC voltmeter according to the table.

Setting	DC-volt. at EXT	DC-volt. at D950.9	DC-volt. at D65.75
FM EXT AC 10 MHz	0 V	2.6 ± 0.2 V	2.6 ± 0.2 V
FM EXT DC 10 MHz	0 V	2.6 ± 0.25 V	2.6 ± 0.25 V
FM EXT DC 10 MHz	1 V	3.8 ± 0.2 V	2.6 ± 0.25 V

7.4.10 FM-Deviation Setting

7.4.10.1 Checking the FM-Diagnostic Detector

(Cf. circuit diagram sheet 7 and 8)

When FM calibration is carried out, the differential deviation in the locked loop is measured using an FM diagnostic detector. To check the detector, a defined frequency deviation is set and the accuracy measured using the detector.

- Settings: **RF 1000 MHz**
 FM EXT AC 50 kHz
 SPEC 116
- Connect AF generator, 1 V_S ± 5 mV, 1 kHz, to input EXT.
- Remove jumper X84.

_ Diagnostic voltage at test point 16: 1.6 ± 0.4 V.

- Set AF frequency fed to 500 Hz, then to 1.5 kHz.

_ Diagnostic voltage at test point 16: < 0.5 V.

- Fit jumper X84.1/2 again.

7.4.10.2 Adjustment of FM-deviation

(Cf. circuit diagram sheet 8)

The scale of the FM-deviation is adjusted via the control branch (control of the division ratio at FRACSYN).

- Settings: **RF 1000 MHz**
 FM EXT AC 500 kHz
- Connect AF generator, 1 V_S ± 5 mV, 50 Hz, to input EXT.
- Connect modulation analyzer with setting HP 10 Hz, TP 3 kHz, detector RMS*², to X124.

_ Use R930 to adjust to an FM-deviation of 500 ± 1 kHz.

_ Perform FM-calibration using **SPEC 43**.

7.4.10.3 Checking FM-Calibration

(Cf. circuit diagram sheet 7)

After calibration, differential deviation is measured with FM modulation in the PLL using the diagnostic detector (cf. 7.4.10.2). Checking is performed in the ground octave from 520 to 1040 MHz in steps of 5 MHz.

- Settings: **RF 520 MHz**
 FM INT 500 kHz
 AF 1 kHz
 SPEC 116
 RF STEP 5 MHz

_ Increase the frequency from 520 MHz to 1040 MHz using the rotary knob. The diagnostic voltage at test point 16 must be in the range 0 ± 50 mV with every frequency.

7.4.11 Transient Response of Synthesis

The transient response of the PI controller voltage with a sudden frequency change between 520 and 1040 MHz is measured.

- Settings: **RF 520 MHz**
 FM OFF
 RF EXT AC

- Connect socket EXTREF of the spectrum analyzer with socket EXTREF at the rear panel of the SMY.
- Connect probe at module strobe HF2STB to X1A.16 and connect with input EXT SWEEP TRG at the rear panel of the spectrum analyzer.
- Connect spectrum analyzer with setting CF 1040 MHz, SPAN 0 Hz, REF LEVEL 10 dBm, LOG RANGE 20 dB, SWEEP 100 ms, RES BW 2.023 kHz, TRIGGER EXTERNAL, SLOPE NEGATIV, TRIGGER LEVEL 238 mV to X124.

- Edge demodulation is necessary to measure the transient response of the synthesis correctly.
The RF frequency of the synthesis module is set to 1040 MHz for preparation. Then the center frequency of the spectrum analyzer is reduced in steps of 100 Hz starting from 1040 MHz in the FREE RUN mode of the analyzer until the value measured is 0 dBm. After switching the synthesis to RF 520 MHz and the analyzer to Trigger External, the frequency changes to 1040 MHz. The setting at the spectrum analyzer corresponds to a scale factor of approx. 120 Hz/dB.

_ 50 ms after the module strobe has been performed (trigger signal), voltage may only vary by maximally ± 100 Hz (approx. 0.85 dB). A voltage characteristic as shown in Fig. 3 is typically obtained.

Fig. 3

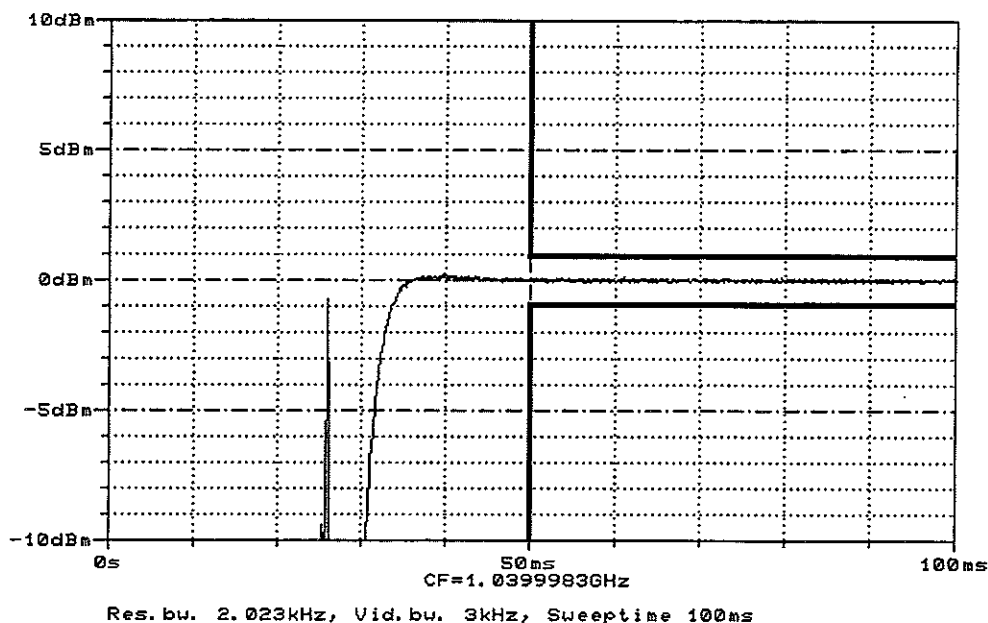

7.4.12 Final Tests of Synthesis

The following final tests should be performed if measurements or a fault recovery have been executed at the module before. The cover on the solder and the component side have to be screwed on now. The module is still located on the test adapter.

7.4.12.1 Residual FM of Synthesizer

- Connect modulation analyzer to X124. Check residual FM using weighting filter 20 Hz to 23 kHz and CCITT at the following frequencies (in MHz):
520, 580, 640, 710, 779, 780, 840, 900, 970, 1040 MHz
- _ Residual FM < 16 Hz_{rms} (20 Hz to 23 kHz)
- _ Residual FM < 8 Hz_{rms} (CCITT)

7.4.12.2 Residual FM 640-MHz Oscillator

- Connect modulation analyzer to X125. Check residual FM using weighting filter 20 Hz to 23 kHz and CCITT.
- Settings: **RF 50 MHz**
 FM OFF
- _ Residual FM < 4 Hz_{rms} (20 Hz to 23 kHz)
- _ Residual FM < 2 Hz_{rms} (CCITT)

7.4.12.3 Spurious of Synthesizer

- Connect spectrum analyzer with setting CF=FREQUENCY, SPAN 50 kHz, RES BW 300 Hz, VIDEO BW 30 Hz, REF LEVEL 15 dBm to X124. Measure suppression of spurious at the following frequencies (in MHz): 520.02, 544.02, 544.08, 640.005, 960.026666, 992.02, 1024.08 MHz
- _ Suppression of spurious ≥ 5 kHz before or after the carrier must be ≥ 70 dBc.

7.4.12.4 FM-DC Center Frequency Calibration

- Settings: RF 1000 MHz
FM EXT DC 10 MHz
 - Connect power supply unit (± 1 V) to socket FM/ ϕ M EXT (the DC voltage set must be sufficiently free of noise and hum!).
 - Connect modulation analyzer including frequency counter to X124.
- _ Set voltage at the power supply unit to 0 mV or short-circuit input socket FM/ ϕ M EXT.
- _ Perform FM-DC Nulling Internal using SPEC 55. The frequency error must be < 10 kHz. Vary the voltage from -1 to $+1$ V and measure residual FM, it must be < 1 kHz_{rms} (weighting bandwidth 300 Hz to 23 kHz). The output frequency varies from 990 to 1010 MHz.

7.4.13 Tables and Interfaces

7.4.13.1 List of Diagnostic Test Points

A diagnostic multiplexer (74HC4051) is used to monitor the important control voltages and levels. The potential of the module ground can be measured to compensate for offset voltages (diagnostic point 9).

	Diagnostic point	Test point	Min. V	Max. V	Division factor
9	R146	Reference, 10 KW	-50 m	50 m	1
10	D-+10REF	10 V, reference volt.	9.9	10.1	3
11	D-PLL-VTCXO	Control volt. VTCXO 10 MHz	0.3	4.7	3
12	D-PLL-640	Control volt. VCO 640 MHz	4	17	5
13	D-REF640	Output level LO, 640 MHz Level switched off	0.1 <0.05	0.6	1
14	D-FSYN	Output level FSYN 65 to 1040 MHz	0.08	0.6	1
15	D-PLL-FSYN	Control voltage VCO's FSYN	1.75	21.5	5
6	D-FM-KAL	Accuracy at PD, 1 kHz	0	50 m	3

7.4.13.2 Digital Interface

Module YSYN has a serial interface according to instrument standard. The data for the HC4094 latches and/or the serial D/A converter are accepted by means of Strobel. Strobe2 is used to effect transfer of the data at FRACSYN.

Polarity clock: active clock edge L-->H
Polarity strobel: active clock edge L-->H
Polarity strobe2: active clock edge H-->L

Data transmission using strobe1 (HF1STB):
 Deviation setting for FM and Φ M, RF-dependent deviation correction, selection of the RF output dividers, diagnosis, operating modes.

The data on strobe1 for the serial D/A converter cannot be accessed from outside and are thus not listed.

Data transmission using strobe2 (HF2STB):
 Frequency information, information for wobble operation and the offset adder.

The data on strobe 2 are determined for component FRACSYN. They cannot be accessed from outside and are hence not listed.

Latch	Pin	Designation	Function		
D585	11	T2	Output divider 4	0=On	1=Off
	12	T1	Output divider 2	0=On	1=Off
	13	S6	Output division path 4,8	0=Off	1=On
	14	S5	Input division path 4	0=Off	1=On
	7	S4	Path iterative network	0=Off	1=On
	6	S3	Output division path 2	0=Off	1=On
	5	S2	Input division path 2,8	0=Off	1=On
	4	S1	No division	0=Off	1=On
D855	11	OSZ2	Oscillator 750 to 1040 MHz	0=Off	1=On
	12	OSZ1	Oscillator 520 to 750 MHz	0=Off	1=On
	13	EXTAC/DC	AC-DC switchover with FM-EXT	0=FMAC	1=FMDC
	14	FMINT	Modulation source INT	0=Off	1=On
	7	FMEXT	Modulation source EXT	0=Off	1=On
	6	DEVCOARSE2	Deviation divider coarse in steps of 12 dB		MSB
	5	DEVCOARSE1			
4	DEVCOARSE0			LSB	
D670	11	PLL-GAIN2	Setting (0 to 7)		MSB
	12	PLL-GAIN1	Open-loop gain		
	13	PLL-GAIN0	for RF-locked loop		LSB
	14	FM/ Φ M	Differentiator with PM	0=FM	1= Φ M
	7	FMDIAOFF	Switching off the FM detector	0=On	1=Off
	6	RESET-FRAC	Master reset FRACSYN		1=Active
	5	S_FM_DIA	Reset rectifier 1 kHz	0=Measure	1=Disch.
	4	S_DSIG	Sigma-Delta converter	0=Off	1=On

	Latch	Pin	Designation	Function	
D665	11	AD15	Setting deviation value at A/D input FRACSYN		MSB
	12	AD14			
	13	AD13			
	14	AD12			
	7	AD11			
	6	AD10			
	5	AD9			
	4	AD8			
D660	11	AD7	Display in dual complement		
	12	AD6			
	13	AD5			
	14	AD4			
	7	AD3			
	6	AD2			
	5	AD1			
	4	AD0			LSB

D110	11	MODOFF	Modulation ON/OFF	0=On	1=Off (CW)
	12	S-REF640	640-MHz output stage	0=Off	1=On
	13	OPTREF	Switchover standard/ option reference	0=Standard	1=Option
	14	INT/EXT	Switchover internal/ external reference	0=Ext. 1=Int.	or Option
	7	DIAGENA	Diagnosis On/Off	0=Off	1=On
	6	DMUX2	Diagnostic multiplexer 0 to 7		MSB
	5	DMUX1			
4	DMUX0			LSB	

7.4.13.3 Operating Points and Levels of RF Amplifiers

A test of the RF paths with regard to quality is only possible using an RF probe at the spectrum analyzer. A short low-impedance ground connection is especially important. The series resistor of the RF probe should be at least 1 k Ω .

The values stated for the DC operating points as well as for the RF level are to be understood as typical values.

Amplifier	Operating point	RF level, frequency	Remark
V205	Pin2 Pin1	2.5 V 1.8 V	RF EXT AC 6 dBm, 10 MHz
V210	Pin2 Pin3	0.7 V 2.1 V	HCT, 10 MHz RF EXT AC
V215	Pin2 Pin3	0.7 V 2.6 V	RF EXT AC 12 dBm, 10 MHz
V216	Pin2 Pin3		RF EXT AC 10 MHz, 0 dBm at EXTREF
V305	Pin3 Pin2,4	- 7.3 V - 7.7 V	HCT, 10 MHz 10 MHz, 0 dBm at EXTREF
N300	Pin1 Pin3	8 dBm, 640 MHz - 3 dBm, 640 MHz	
V330	Pin1 Pin2 Pin3 Pin4	4.6 V 2 V 7.1 V 1.75 V 0.55 V	7 dBm, 640 MHz RF 50 MHz 14 dBm, 640 MHz 5.5 dBm, 640 MHz
V370	Pin2 Pin3	0.6 V 2.2 V	Terminate X125 using 50- Ω resistor
V404	Pin3 Pin2,4	-5.8 V -6.1 V	HCT, 10 MHz RF 520 MHz
V434	Pin3 Pin2,4	-5.8 V -6.1 V	7 dBm, 780 MHz 9.5 dBm, 780 MHz
N490	Pin1 Pin3	- 5 dBm, 1000 MHz 4.6 V	RF 1000 MHz 3 dBm, 1000 MHz
N500	Pin1 Pin3	- 2 dBm, 1000 MHz 4.7 V	RF 1000 MHz 2 dBm, 1000 MHz
N510	Pin1 Pin3	- 6 dBm, 500 MHz 4.4 V	RF 500 MHz 2 dBm, 500 MHz
N520	Pin1 Pin3	- 7 dBm, 250 MHz 4.6 V	Terminate X124 using 50- Ω resistor RF 250 MHz
N560	Pin1 Pin3	2 dBm, 1000 MHz 4.8 V	Terminate X124 using 50- Ω resistor RF 1000 MHz
N600	Pin1 Pin3	- 7 dBm, 1000 MHz 4.6 V	RF 1000 MHz 2 dBm, 1000 MHz
N610	Pin1 Pin3	- 7.5 dBm, 1000 MHz 4.7 V	RF 1000 MHz 0 dBm, 1000 MHz
V600	Pin2 Pin3	0.75 V 0.95 V	RF 1000 MHz 10 dBm, 62.5 MHz

7.5 Disassembly and Assembly

In order to be able to remove the YSYN module, only the bottom of the instrument needs to be opened. First the computer module is removed. Open the two lateral screws and withdraw the cable for the IEC-bus leading to the rear panel. The processor can now be withdrawn, the cables for keyboard/display as well as to the motherboard remain plugged in.

After undoing the two lateral screws of the synthesis module, the three or four (if optional quartz existing) RF connections at the module can be withdrawn or unscrewed. The YSYN module is now taken out of its slot sideways to the rear.

The synthesis module can now be connected with the motherboard again via the ribbon cable in the service kit. Sockets X127 and X128 are also connected to the corresponding connections EXTREF and, if existing, with the optional oscillator via the coaxial cables in the service kit.

The screening covers are screwed in the usual manner. In the case of operation with the screening cover opened, please ensure that the resonator chambers E and F are closed using suitable test covers on both sides.

7.6 External Interfaces

The data for the current consumption of the respective supply voltage refers to the state of the module after a **PRESET**.

Pin	Name	Input/Output	Origin/Dest.	Value range	Signal description
X1A.4	EXT1	Input	Front unit	1V _s	Modulation voltage
X1A.6	INT1	Input	Processor X3.32	1V _s	Modulation voltage
X1A.8	FMKOMPLO	Output	Processor X3.23	HCMOS level	Level monitoring EXT
X1A.9	FMKOMPFI	Output	Processor X3.24	HCMOS level	Level monitoring EXT
X1A.10	OPTUNE	Output	Power supply unit	X21.24	0 to 10V Tuning voltage for optional reference (SM-B1)
X1A.12	SERCLK	Input	Processor X3.2	HCMOS level	Clock for data transmission
X1A.14	SERDAT	Input	Processor X3.4	HCMOS level	Serial data
X1A.15	HF1STB	Input	Processor X3.14	HCMOS level	Strobel
X1A.16	HF2STB	Input	Processor X3.15	HCMOS level	Strobe2
X1A.17	HFINT	Output	Processor X3.20	TTL level	Interrupt PLLs
X1A.19	DIAG-5V	Output	Processor X3.6	0 to 5V	Diagnosis
X1A.22	VA24-P	Input	Power X21.22	23.0 to 25.0 V 12 ± 5 mA	Supply voltage analog
X1A.24	VA15-P	Input	Power X21.13	14.4 to 15.6 V 110 ± 25 mA	Supply voltage analog
X1A.25	VA15-P	Input	Power X21.13	14.4 to 15.6 V 110 ± 25 mA	Supply voltage analog
X1A.26	VA7.5-P	Input	Power X21.8	7.2 to 7.8 V 650 ± 100 mA	Supply voltage analog
X1A.28	VA-5P	Input	Power X21.5	4.9 to 5.3 V 35 ± 10 mA	Supply voltage digital
X1A.30	VA15-N	Input	Power X21.19	-15.6 to 14.4 V -195 ± 35 mA	Supply voltage analog
X128	OPT10	Input	Reference osc.	7.5 ± 1.5 dBm	10 MHz ± 5 ppm
X127	EXTREF	Bidir.	Rear panel	5/10 MHz ± 3ppm -13 to 13 dBm	Input reference
X124	FSYN	Output	Output section	10MHz, 6 to 10 dBm 7 to 14 dBm	Output reference Synthesis freq 65 to 1040 MHz
X125	REF640	Output	Output section	8 to 12 dBm	Reference 640 MHz



ROHDE & SCHWARZ

**Schalteillisten
numerisch geordnet**

**Part lists
in numerical order**

**Listes des pièces détachées
par numéros de référence**

Für diese Unterlegte behalten wir uns alle Rechte vor.

Kennz. Comp. No.	Benennung Designation	Sachnummer Stock No.	Hersteller Manufacturer	Bezeichnung Designation	enthalten In contained in	
	XX VARIANTENERKLAERUNG IDENTIFICATION OF MODELS VAR02=GRUNDAUSFUEHRUNG MOD02=BASIC MODEL VAR 04 = SMY41/44/45 MOD 04 = SMY41/44/45 VAR 43 = FUER IS-98 TEST MOD 43 = FOR IS-98 TEST					
B360	BL PMB2312 1:129MAX PRESC IC PRESCALER	2024.1397.00	SIEMENS	PMB2312T		
C1	CE 220UF+-20%10V RM2,5 ELECTROLYTIC CAPACITOR	CE 0008.7927.00	PANASONIC	ECA-1AFG221I		
C2	CE 47UF+-20%50V RM2,5 ELECTROLYTIC CAPACITOR	CE 0008.7479.00	PANASONIC	ECA-1HFG470I		
C3	CE 100UF+-20%25V RM2.5 ELECTROLYTIC CAPACITOR	CE 0008.7891.00	PANASONIC	ECA-1EFG101I		
C20	CC 100NF+-10%50V X7R 1206 CERAMIC CHIP CAPACITOR	CC 0007.5237.00	PHILIPS_CO	2238 581 15649		
C21	CE 1UF +-10% 25V EIA3528 TANTALUM SMD-CAPACITOR	CE 0007.7217.00	SPRAGUE	293D 105 X9 025 B2T		
C25	CC 330PF+-1%50V NPO 1206 CERAMIC CHIP CAPACITOR	CC 0099.8873.00	PHILIPS_CO	2238 863 18331		
C26	CE 10UF+-20%35V 7343 SMD-TANTALUM CAPACITOR	1078.3291.00	SIEMENS	B45197-A6106-M40*		
C27	CE 10UF+-20%35V 7343 SMD-TANTALUM CAPACITOR	1078.3291.00	SIEMENS	B45197-A6106-M40*		
C30	CC 100NF+-10%50V X7R 1206 CERAMIC CHIP CAPACITOR	CC 0007.5237.00	PHILIPS_CO	2238 581 15649		
C100	CC 100NF+-10%50V X7R 1206 CERAMIC CHIP CAPACITOR	CC 0007.5237.00	PHILIPS_CO	2238 581 15649		
C110	CC 100NF+-10%50V X7R 1206 CERAMIC CHIP CAPACITOR	CC 0007.5237.00	PHILIPS_CO	2238 581 15649		
C120	CC 100NF+-10%50V X7R 1206 CERAMIC CHIP CAPACITOR	CC 0007.5237.00	PHILIPS_CO	2238 581 15649		
C200	CC 100NF+-10%50V X7R 1206 CERAMIC CHIP CAPACITOR	CC 0007.5237.00	PHILIPS_CO	2238 581 15649		
C202	CC 100NF+-10%50V X7R 1206 CERAMIC CHIP CAPACITOR	CC 0007.5237.00	PHILIPS_CO	2238 581 15649		
C204	CC 10NF+-10%50V X7R 1206 CERAMIC CHIP CAPACITOR	CC 0099.8521.00	MURATA	GRM42-6X7R103K 50PT		
C205	CC 1NF+-1% 50V NPO 1206 SMD CERAMIC CAPACITOR	CC 0007.7398.00	PHILIPS_CO	2222 863 *8102		
C206	CC 100NF+-10%50V X7R 1206 CERAMIC CHIP CAPACITOR	CC 0007.5237.00	PHILIPS_CO	2238 581 15649		
C208	CC 10NF+-10%50V X7R 1206 CERAMIC CHIP CAPACITOR	CC 0099.8521.00	MURATA	GRM42-6X7R103K 50PT		
C210	CC 100NF+-10%50V X7R 1206 CERAMIC CHIP CAPACITOR	CC 0007.5237.00	PHILIPS_CO	2238 581 15649		
C214	CC 56PF+-1%50V NPO 1206 CERAMIC CHIP CAPACITOR	CC 0099.8809.00	MURATA	GRM42-6COG 560F 50PT		
C217	CC 470PF+-1%50V NPO 1206 CERAMIC CHIP CAPACITOR	CC 0099.8515.00	PHILIPS_CO	2238 863 18471		
C217	CC 470PF+-1%50V NPO 1206 CERAMIC CHIP CAPACITOR NUR VAR/ONLY MOD: 02 43	CC 0099.8515.00	PHILIPS_CO	2238 863 18471		
C218	CC 680PF+-1% 50V NPO 1206 CERAMIC CHIP CAPACITOR NUR VAR/ONLY MOD: 02 43	CC 0007.7375.00	PHILIPS_CO	2222 863 18681		
C218	CC 680PF+-1% 50V NPO 1206 CERAMIC CHIP CAPACITOR NUR VAR/ONLY MOD: 04	CC 0007.7375.00	PHILIPS_CO	2222 863 18681		
C219	CC 470PF+-1%50V NPO 1206 CERAMIC CHIP CAPACITOR NUR VAR/ONLY MOD: 02 43	CC 0099.8515.00	PHILIPS_CO	2238 863 18471		
C219	CC 470PF+-1%50V NPO 1206 CERAMIC CHIP CAPACITOR NUR VAR/ONLY MOD: 04	CC 0099.8515.00	PHILIPS_CO	2238 863 18471		
C220	CC 100NF+-10%50V X7R 1206 CERAMIC CHIP CAPACITOR	CC 0007.5237.00	PHILIPS_CO	2238 581 15649		
C221	CC 100NF+-10%50V X7R 1206 CERAMIC CHIP CAPACITOR	CC 0007.5237.00	PHILIPS_CO	2238 581 15649		
MENP5	413 3PUA	Ät	Datum Date	Schaltteilleiste für Parts list for	Sachnummer Stock No.	Blatt-Nr. Page
	ROHDE & SCHWARZ	31	16.09.97	EE SYNTHESIZER SYNTHESIZER	1062.6409.01 SA	1+

095.0028-0893

Kennz. Comp. No.	Benennung Designation	Sachnummer Stock No.	Hersteller Manufacturer	Bezeichnung Designation	enthalten in contained in
C222	CC 100PF+-1%50V NPO 1206 CERAMIC CHIP CAPACITOR	CC 0099.8415.00	MURATA	GRM42-6COG 101F 50PT	
C224	CC 100NF+-10%50V X7R 1206 CERAMIC CHIP CAPACITOR	CC 0007.5237.00	PHILIPS_CO	2238 581 15649	
C225	CC 220PF+-1%50V NPO 1206 CERAMIC CHIP CAPACITOR	CC 0099.8850.00	PHILIPS_CO	2238 863 18221	
C227	CC 1NF+-1% 50V NPO 1206 SMD CERAMIC CAPACITOR TRIMMWERT 820PF - 1.2NF	CC 0007.7398.00	PHILIPS_CO	2222 863 *8102	
C228	CC 100PF+-1%50V NPO 1206 CERAMIC CHIP CAPACITOR	CC 0099.8415.00	MURATA	GRM42-6COG 101F 50PT	
C230	CC 100PF+-1%50V NPO 1206 CERAMIC CHIP CAPACITOR	CC 0099.8415.00	MURATA	GRM42-6COG 101F 50PT	
C232	CC 1NF+-1% 50V NPO 1206 SMD CERAMIC CAPACITOR NUR VAR/ONLY MOD: 02 43	CC 0007.7398.00	PHILIPS_CO	2222 863 *8102	
C232	RG 0-OHM WIDERSTAND-CHIP RESISTOR CHIP 0-OHM NUR VAR/ONLY MOD: 04	RG 0007.5108.00	DRALORIC	CR 1206	
C234	CC 330PF+-1%50V NPO 1206 CERAMIC CHIP CAPACITOR	CC 0099.8873.00	PHILIPS_CO	2238 863 18331	
C235	CC 330PF+-1%50V NPO 1206 CERAMIC CHIP CAPACITOR	CC 0099.8873.00	PHILIPS_CO	2238 863 18331	
C236	CC 15PF+-1% 50V NPO 1206 CERAMIC CHIP CAPACITOR	CC 0099.8750.00	MURATA	GRM42-6COG 150F 50PT	
C237	CC 1,0NF+-10%50V HDK 0603 SMD-CERAMIC-CAPACITOR NUR VAR/ONLY MOD: 04	CC 0009.4938.00	MURATA	GRM39X7R***K50C500PT	
C240	CC 1NF+-1% 50V NPO 1206 SMD CERAMIC CAPACITOR	CC 0007.7398.00	PHILIPS_CO	2222 863 *8102	
C245	CC 220NF+-10%50V X7R 1210 CERAMIC CAPACITOR CHIP	CC 0520.6850.00	AVX	1210 5C 224KA 11A	
C250	CC 22PF+-1%50V NPO 1206 CERAMIC CHIP CAPACITOR	CC 0099.8396.00	MURATA	GRM42-6COG 220F 50PT	
C252	CC 1,5NF+-1% 50V NPO 1206 CERAMIC CHIP CAPACITOR	CC 0007.7417.00	PHILIPS_CO	2222 863 18152	
C254	CC 1,5NF+-1% 50V NPO 1206 CERAMIC CHIP CAPACITOR	CC 0007.7417.00	PHILIPS_CO	2222 863 18152	
C255	CC 100NF+-10%50V X7R 1206 CERAMIC CHIP CAPACITOR	CC 0007.5237.00	PHILIPS_CO	2238 581 15649	
C256	CK 470NF+-5% 25V PPS 2824 SMD-FILM-CAPACITOR	0010.6853.00	PHILIPS_CO	2222 394 29474	
C258	CC 47NF+-10%50V X7R 1206 CERAMIC CHIP CAPACITOR	CC 0007.5195.00	PHILIPS_CO	2238 581 15645	
C260	CC 100NF+-10%50V X7R 1206 CERAMIC CHIP CAPACITOR	CC 0007.5237.00	PHILIPS_CO	2238 581 15649	
C261	CE 1UF +-10% 10V 1206 TANTALUM-SMD-CAPACITOR	CE 0007.7252.00	SPRAGUE	293D 105 X9 010 D2T	
C286	CC 100PF+-1%50V NPO 1206 CERAMIC CHIP CAPACITOR	CC 0099.8415.00	MURATA	GRM42-6COG 101F 50PT	
C300	CC 100PF+-1%50V NPO 1206 CERAMIC CHIP CAPACITOR	CC 0099.8415.00	MURATA	GRM42-6COG 101F 50PT	
C302	CC 3,3PF+-0,25 50V NPO 1206 CERAMIC CHIP CAPACITOR	CC 0007.8194.00	MURATA	GRM42-6COG 3R3 C50PT	
C304	CC 1,8PF0,25PF NPO 0805 CHIP CAPACITOR	CC 0099.6806.00	PHILIPS_CO	2222 861 12188	
C306	CC 6,8PF0,5PF NPO 0805 CAPACITOR	CC 0093.2167.00	PHILIPS_CO	2222 861 15688	
C308	CC 7,8PF0,25PF NPO 0805 CERAMIC CHIP CAPACITOR	CC 0099.8296.00	PHILIPS_CO	2222 861 14788	
C310	CC 100PF+-1%50V NPO 1206 CERAMIC CHIP CAPACITOR	CC 0099.8415.00	MURATA	GRM42-6COG 101F 50PT	
C312	CE 2,2UF +-10% 25V 6032 TANTALUM SMD-CAPACITOR	CE 0007.7223.00	KEMET	T491 C225 K 025 AS	
C314	CC 100NF+-10%50V X7R 1206 CERAMIC CHIP CAPACITOR	CC 0007.5237.00	PHILIPS_CO	2238 581 15649	
C316	CC 100PF+-1%50V NPO 1206 CERAMIC CHIP CAPACITOR	CC 0099.8415.00	MURATA	GRM42-6COG 101F 50PT	
C320	CC 100NF+-10%50V X7R 1206 CERAMIC CHIP CAPACITOR	CC 0007.5237.00	PHILIPS_CO	2238 581 15649	
C324	CC 100PF+-1%50V NPO 1206 CERAMIC CHIP CAPACITOR	CC 0099.8415.00	MURATA	GRM42-6COG 101F 50PT	
C331	CC 100PF+-1%50V NPO 1206 CERAMIC CHIP CAPACITOR	CC 0099.8415.00	MURATA	GRM42-6COG 101F 50PT	
C335	CC 100PF+-1%50V NPO 1206 CERAMIC CHIP CAPACITOR	CC 0099.8415.00	MURATA	GRM42-6COG 101F 50PT	
C336	CC 220PF+-10% X7R 0805 CERAMIC CHIP CAPACITOR	CC 0099.8367.00	MURATA	GRM40 X7R221K50PT	

Für diese Unterlage behalten wir uns alle Rechte vor.

095.0028-0893

MENP5	413 3PUA	ÄI	Datum Date	Schaltteilliste für Parts list for	Sachnummer Stock No.	Blatt-Nr. Page
	ROHDE & SCHWARZ	31	16.09.97	EE SYNTHESIZER SYNTHESIZER	1062.6409.01 SA	2+

Für diese Unterlage behalten wir uns alle Rechte vor.

Kennz. Comp. No.	Benennung Designation	Sachnummer Stock No.	Hersteller Manufacturer	Bezeichnung Designation	enthalten in contained in
C338	CC 100PF+-1%50V NPO 1206 CERAMIC CHIP CAPACITOR	CC 0099.8415.00	MURATA	GRM42-6COG 101F 50PT	
C342	CC 100PF+-1%50V NPO 1206 CERAMIC CHIP CAPACITOR	CC 0099.8415.00	MURATA	GRM42-6COG 101F 50PT	
C344	CC 2,2PF+-0,25 50VNPO1206 CERAMIC CHIP CAPACITOR	CC 0007.8171.00	MURATA	GRM42-6COG 2R2 C50PT	
C345	CC 100PF+-10% NPO 0805 CAPACITOR	CC 0082.2948.00	MURATA	GRM40 COG 101 K50PT	
C346	CC 1NF+-1% 50V NPO 1206 SMD CERAMIC CAPACITOR	CC 0007.7398.00	PHILIPS_CO	2222 863 *8102	
C347	CC 1PF+-0,25 50V NPO 1206 CERAMIC CHIP CAPACITOR	CC 0099.8667.00	PHILIPS_CO	2238 863 15108	
C348	CC 1NF+-1% 50V NPO 1206 SMD CERAMIC CAPACITOR	CC 0007.7398.00	PHILIPS_CO	2222 863 *8102	
C349	CC 100PF+-1%50V NPO 1206 CERAMIC CHIP CAPACITOR	CC 0099.8415.00	MURATA	GRM42-6COG 101F 50PT	
C360	CC 1NF+-1% 50V NPO 1206 SMD CERAMIC CAPACITOR	CC 0007.7398.00	PHILIPS_CO	2222 863 *8102	
C361	CC 100NF+-10%50V X7R 1206 CERAMIC CHIP CAPACITOR	CC 0007.5237.00	PHILIPS_CO	2238 581 15649	
C370	CC 1NF+-1% 50V NPO 1206 SMD CERAMIC CAPACITOR	CC 0007.7398.00	PHILIPS_CO	2222 863 *8102	
C373	CC 100NF+-10%50V X7R 1206 CERAMIC CHIP CAPACITOR	CC 0007.5237.00	PHILIPS_CO	2238 581 15649	
C400	CC 10PF+-0,25 50VNPO 1206 CERAMIC CHIP CAPACITOR	CC 0099.8480.00	MURATA	GRM42-6COG 100 C50PT	
C402	CC 47PF+-5% 500V PELL CAPACITOR	CC 0467.9761.00	TEKELEC	501 CHB 470 JWL	
C404	CC 10PF+-0,25 50VNPO 1206 CERAMIC CHIP CAPACITOR	CC 0099.8480.00	MURATA	GRM42-6COG 100 C50PT	
C406	CC 4,1PFO,25PF NPO 0805 CAPACITOR	CC 0093.5637.00	VITRAMON	VJ0805A...FA	
C408	CC 6,8PFO,5PF NPO 0805 CAPACITOR	CC 0093.2167.00	PHILIPS_CO	2222 861 15688	
C410	CC 6PF+-0,25PF NPO 0805 CERAMIC CHIP CAPACITOR	CC 0099.8280.00	MURATA	GRM40 COG 6R0 C50PT	
C412	CC 12PF+-5%100V NPO 0805 CERAMIC CAPACITOR	CC 0022.3948.00	PHILIPS_CO	2222 861 15129	
C414	CC 100PF+-1%50V NPO 1206 CERAMIC CHIP CAPACITOR	CC 0099.8415.00	MURATA	GRM42-6COG 101F 50PT	
C416	CC 100PF+-1%50V NPO 1206 CERAMIC CHIP CAPACITOR	CC 0099.8415.00	MURATA	GRM42-6COG 101F 50PT	
C418	CC 10PF+-0,25 50VNPO 1206 CERAMIC CHIP CAPACITOR	CC 0099.8480.00	MURATA	GRM42-6COG 100 C50PT	
C425	CC 100PF+-1%50V NPO 1206 CERAMIC CHIP CAPACITOR	CC 0099.8415.00	MURATA	GRM42-6COG 101F 50PT	
C430	CC 10PF+-0,25 50VNPO 1206 CERAMIC CHIP CAPACITOR	CC 0099.8480.00	MURATA	GRM42-6COG 100 C50PT	
C432	CC 8,2+-0,1PF 500V PELL CAPACITOR	CC 0552.1648.00	TEKELEC	501 CHB 8R2 BW(V)LE	
C432	NUR VAR/ONLY MOD: 02 CC 4,7PF+-0,1PF500V PELL CAPACITOR	CC 0580.9540.00	ATC	ATC100B 4R7 BW500XR	
C434	NUR VAR/ONLY MOD: 43 CC 10PF+-0,25 50VNPO 1206 CERAMIC CHIP CAPACITOR	CC 0099.8480.00	MURATA	GRM42-6COG 100 C50PT	
C436	CC 2,9PFO,25PF NPO 0805 CAPACITOR	CC 0093.5589.00	VITRAMON	VJ0805A...XA	
C438	CC 4,3PFO,25PF NPO 0805 CAPACITOR	CC 0093.5643.00	MURATA	GRM40COG4R3C50PT	
C440	CC 3,3PFO,25PF NPO 0805 CERAMIC CHIP CAPACITOR	CC 0099.8273.00	PHILIPS_CO	2222 861 12338	
C442	CC 7,8PFO,25PF NPO 0805 CERAMIC CHIP CAPACITOR	CC 0099.8296.00	PHILIPS_CO	2222 861 14788	
C444	CC 100PF+-1%50V NPO 1206 CERAMIC CHIP CAPACITOR	CC 0099.8415.00	MURATA	GRM42-6COG 101F 50PT	
C446	CC 100PF+-1%50V NPO 1206 CERAMIC CHIP CAPACITOR	CC 0099.8415.00	MURATA	GRM42-6COG 101F 50PT	
C448	CC 10PF+-0,25 50VNPO 1206 CERAMIC CHIP CAPACITOR	CC 0099.8480.00	MURATA	GRM42-6COG 100 C50PT	
C455	CC 100PF+-1%50V NPO 1206 CERAMIC CHIP CAPACITOR	CC 0099.8415.00	MURATA	GRM42-6COG 101F 50PT	
C490	CC 100NF+-10%50V X7R 1206 CERAMIC CHIP CAPACITOR	CC 0007.5237.00	PHILIPS_CO	2238 581 15649	
C491	CE 10UF+-20%35V 7343 SMD-TANTALUM CAPACITOR	1078.3291.00	SIEMENS	B45197-A6106-M40*	
C492	CC 100PF+-1%50V NPO 1206 CERAMIC CHIP CAPACITOR	CC 0099.8415.00	MURATA	GRM42-6COG 101F 50PT	

MENP5

413 3PUA

AI

Datum Date

31 16.09.97

Schaltteilliste für Parts list for

EE SYNTHESIZER
SYNTHESIZER

Sachnummer Stock No.

1062.6409.01 SA

Blatt-Nr. Page

3+



ROHDE & SCHWARZ

Kennz. Comp. No.	Benennung Designation	Sachnummer Stock No.	Hersteller Manufacturer	Bezeichnung Designation	enthalten in contained in
C493	CC 100PF+-1%50V NPO 1206 CERAMIC CHIP CAPACITOR	CC 0099.8415.00	MURATA	GRM42-6COG 101F 50PT	
C494	CC 100NF+-10%50V X7R 1206 CERAMIC CHIP CAPACITOR	CC 0007.5237.00	PHILIPS_CO	2238 581 15649	
C500	CC 22PF+-1%50V NPO 1206 CERAMIC CHIP CAPACITOR	CC 0099.8396.00	MURATA	GRM42-6COG 220F 50PT	
C501	CC 100PF+-1%50V NPO 1206 CERAMIC CHIP CAPACITOR	CC 0099.8415.00	MURATA	GRM42-6COG 101F 50PT	
C502	CC 100NF+-10%50V X7R 1206 CERAMIC CHIP CAPACITOR	CC 0007.5237.00	PHILIPS_CO	2238 581 15649	
C505 .507	CC 1NF+-1% 50V NPO 1206 SMD CERAMIC CAPACITOR	CC 0007.7398.00	PHILIPS_CO	2222 863 *8102	
C510	CC 100PF+-1%50V NPO 1206 CERAMIC CHIP CAPACITOR	CC 0099.8415.00	MURATA	GRM42-6COG 101F 50PT	
C511 .514	CC 1NF+-1% 50V NPO 1206 SMD CERAMIC CAPACITOR	CC 0007.7398.00	PHILIPS_CO	2222 863 *8102	
C515	CC 100NF+-10%50V X7R 1206 CERAMIC CHIP CAPACITOR	CC 0007.5237.00	PHILIPS_CO	2238 581 15649	
C516	CC 100PF+-1%50V NPO 1206 CERAMIC CHIP CAPACITOR	CC 0099.8415.00	MURATA	GRM42-6COG 101F 50PT	
C517	CC 100PF+-1%50V NPO 1206 CERAMIC CHIP CAPACITOR	CC 0099.8415.00	MURATA	GRM42-6COG 101F 50PT	
C520	CC 100PF+-1%50V NPO 1206 CERAMIC CHIP CAPACITOR	CC 0099.8415.00	MURATA	GRM42-6COG 101F 50PT	
C521 .524	CC 1NF+-1% 50V NPO 1206 SMD CERAMIC CAPACITOR	CC 0007.7398.00	PHILIPS_CO	2222 863 *8102	
C525	CC 100NF+-10%50V X7R 1206 CERAMIC CHIP CAPACITOR	CC 0007.5237.00	PHILIPS_CO	2238 581 15649	
C526	CC 100PF+-1%50V NPO 1206 CERAMIC CHIP CAPACITOR	CC 0099.8415.00	MURATA	GRM42-6COG 101F 50PT	
C527	CC 100PF+-1%50V NPO 1206 CERAMIC CHIP CAPACITOR	CC 0099.8415.00	MURATA	GRM42-6COG 101F 50PT	
C530	CC 1NF+-1% 50V NPO 1206 SMD CERAMIC CAPACITOR	CC 0007.7398.00	PHILIPS_CO	2222 863 *8102	
C532	CC 100PF+-1%50V NPO 1206 CERAMIC CHIP CAPACITOR	CC 0099.8415.00	MURATA	GRM42-6COG 101F 50PT	
C550	CC 330PF+-1%50V NPO 1206 CERAMIC CHIP CAPACITOR	CC 0099.8873.00	PHILIPS_CO	2238 863 18331	
C551	CC 330PF+-1%50V NPO 1206 CERAMIC CHIP CAPACITOR	CC 0099.8873.00	PHILIPS_CO	2238 863 18331	
C552	CC 100NF+-10%50V X7R 1206 CERAMIC CHIP CAPACITOR	CC 0007.5237.00	PHILIPS_CO	2238 581 15649	
C553	CC 100NF+-10%50V X7R 1206 CERAMIC CHIP CAPACITOR	CC 0007.5237.00	PHILIPS_CO	2238 581 15649	
C555	CC 1PF+-0,25 50V NPO 1206 CERAMIC CHIP CAPACITOR	CC 0099.8667.00	PHILIPS_CO	2238 863 15108	
C556	CC 1NF+-1% 50V NPO 1206 SMD CERAMIC CAPACITOR	CC 0007.7398.00	PHILIPS_CO	2222 863 *8102	
C557	CC 100PF+-1%50V NPO 1206 CERAMIC CHIP CAPACITOR	CC 0099.8415.00	MURATA	GRM42-6COG 101F 50PT	
C570	CC 1NF+-1% 50V NPO 1206 SMD CERAMIC CAPACITOR	CC 0007.7398.00	PHILIPS_CO	2222 863 *8102	
C571	CC 1NF+-1% 50V NPO 1206 SMD CERAMIC CAPACITOR	CC 0007.7398.00	PHILIPS_CO	2222 863 *8102	
C580	CC 100NF+-10%50V X7R 1206 CERAMIC CHIP CAPACITOR	CC 0007.5237.00	PHILIPS_CO	2238 581 15649	
C600	CC 10PF+-0,25 50VNPO 1206 CERAMIC CHIP CAPACITOR	CC 0099.8480.00	MURATA	GRM42-6COG 100 C5OPT	
C601	CC 10PF+-0,25 50VNPO 1206 CERAMIC CHIP CAPACITOR	CC 0099.8480.00	MURATA	GRM42-6COG 100 C5OPT	
C602	CC 100NF+-10%50V X7R 1206 CERAMIC CHIP CAPACITOR	CC 0007.5237.00	PHILIPS_CO	2238 581 15649	
C604	CC 4,7PF+-0,25 50VNPO1206 CERAMIC CHIP CAPACITOR	CC 0007.8213.00	MURATA	GRM42-6COG 4R7C 50PT	
C605	CC 10PF+-0,25 50VNPO 1206 CERAMIC CHIP CAPACITOR	CC 0099.8480.00	MURATA	GRM42-6COG 100 C5OPT	
C610	CC 100NF+-10%50V X7R 1206 CERAMIC CHIP CAPACITOR	CC 0007.5237.00	PHILIPS_CO	2238 581 15649	
C615	CC 10PF+-0,25 50VNPO 1206 CERAMIC CHIP CAPACITOR	CC 0099.8480.00	MURATA	GRM42-6COG 100 C5OPT	
C616	CC 100PF+-1%50V NPO 1206 CERAMIC CHIP CAPACITOR	CC 0099.8415.00	MURATA	GRM42-6COG 101F 50PT	
C620	CC 100PF+-1%50V NPO 1206 CERAMIC CHIP CAPACITOR	CC 0099.8415.00	MURATA	GRM42-6COG 101F 50PT	
C621	CC 100NF+-10%50V X7R 1206 CERAMIC CHIP CAPACITOR	CC 0007.5237.00	PHILIPS_CO	2238 581 15649	
C625	CC 100PF+-1%50V NPO 1206 CERAMIC CHIP CAPACITOR	CC 0099.8415.00	MURATA	GRM42-6COG 101F 50PT	

Für diese Unterlage behalten wir uns alle Rechte vor.

MENP5	413 3PUA	Äi	Datum Date	Schaltteilliste für Parts list for	Sachnummer Stock No.	Blatt-Nr. Page
		31	16.09.97	EE SYNTHESIZER SYNTHESIZER	1062.6409.01 SA	4+

095.0026-0693

Für diese Unterlage behalten wir uns alle Rechte vor.

Kennz. Comp. No.	Benennung Designation	Sachnummer Stock No.	Hersteller Manufacturer	Bezeichnung Designation	enthalten in contained in
C630	CC 100PF+-1%50V NPO 1206 CERAMIC CHIP CAPACITOR	CC 0099.8415.00	MURATA	GRM42-6COG 101F 50PT	
C631	CC 100NF+-10%50V X7R 1206 CERAMIC CHIP CAPACITOR	CC 0007.5237.00	PHILIPS_CO	2238 581 15649	
C633	CC 100PF+-1%50V NPO 1206 CERAMIC CHIP CAPACITOR	CC 0099.8415.00	MURATA	GRM42-6COG 101F 50PT	
C640	CC 100NF+-10%50V X7R 1206 CERAMIC CHIP CAPACITOR	CC 0007.5237.00	PHILIPS_CO	2238 581 15649	
C645	CC 100NF+-10%50V X7R 1206 CERAMIC CHIP CAPACITOR	CC 0007.5237.00	PHILIPS_CO	2238 581 15649	
C650	CE 22UF +-10% 10V 7343 TANTALUM SMD-CAPACITOR	CE 0007.7298.00	KEMET	T491 D 226 K 010 AS	
C655	CC 100NF+-10%50V X7R 1206 CERAMIC CHIP CAPACITOR	CC 0007.5237.00	PHILIPS_CO	2238 581 15649	
C661	CC 220PF+-1%50V NPO 1206 CERAMIC CHIP CAPACITOR	CC 0099.8850.00	PHILIPS_CO	2238 863 18221	
C662	CC 100PF+-1%50V NPO 1206 CERAMIC CHIP CAPACITOR	CC 0099.8415.00	MURATA	GRM42-6COG 101F 50PT	
C690	CC 220NF+-10%50V X7R 1210 CERAMIC CAPACITOR CHIP	CC 0520.6850.00	AVX	1210 5C 224KA 11A	
..693					
C698	CE 22UF +-10% 10V 7343 TANTALUM SMD-CAPACITOR	CE 0007.7298.00	KEMET	T491 D 226 K 010 AS	
C701	CC 10NF+-10%50V X7R 1206 CERAMIC CHIP CAPACITOR	CC 0099.8521.00	MURATA	GRM42-6X7R103K 50PT	
C702	CC 10NF+-10%50V X7R 1206 CERAMIC CHIP CAPACITOR	CC 0099.8521.00	MURATA	GRM42-6X7R103K 50PT	
C705	CC 100NF+-10%50V X7R 1206 CERAMIC CHIP CAPACITOR	CC 0007.5237.00	PHILIPS_CO	2238 581 15649	
C710	CC 22PF+-1%50V NPO 1206 CERAMIC CHIP CAPACITOR	CC 0099.8396.00	MURATA	GRM42-6COG 220F 50PT	
C712	CE 4,7U F+-10% 10V 3528 TANTALUM SMD-CAPACITOR	CE 0007.7275.00	SPRAGUE	293D 475 X9 010 B2T	
C719	CE 1UF +-10% 25V EIA3528 TANTALUM SMD-CAPACITOR	CE 0007.7217.00	SPRAGUE	293D 105 X9 025 B2T	
C720	CC 1NF+-1% 50V NPO 1206 SMD CERAMIC CAPACITOR	CC 0007.7398.00	PHILIPS_CO	2222 863 *8102	
C721	CK 470NF+-5% 25V PPS 2824 SMD-FILM-CAPACITOR	0010.6853.00	PHILIPS_CO	2222 394 29474	
C722	CC 22PF+-1%50V NPO 1206 CERAMIC CHIP CAPACITOR	CC 0099.8396.00	MURATA	GRM42-6COG 220F 50PT	
C731	CK 220NF+-5% 25V PPS 2220 SMD-FILM-CAPACITOR	0009.7872.00	PHILIPS_CO	2222 393 29224	
C750	CE 47UF+-20%50V RM2,5 ELECTROLYTIC CAPACITOR	CE 0008.7479.00	PANASONIC	ECA-1HFG470I	
C753	CC 100PF+-1%50V NPO 1206 CERAMIC CHIP CAPACITOR	CC 0099.8415.00	MURATA	GRM42-6COG 101F 50PT	
C760	CC 8,2NF+-10%50V X7R 1206 CERAMIC CHIP KONDENSATOR	CC 0007.3257.00	PHILIPS_CO	2238 581 16626	
C764	CK 1,5UF+-5% 50V RD5,5H12 CAPACITOR	CK 0008.1141.00	ROE	MKT1826-515/054	
C765	CK 1,5UF+-5% 50V RD5,5H12 CAPACITOR	CK 0008.1141.00	ROE	MKT1826-515/054	
C779	CK 100NF+-5% 25V PPS 2220 SMD-FILM	1066.2037.00	PHILIPS_CO	2222 393 29104	
C780	CC 1,8NF+-1% 50V NPO 1206 CERAMIC CHIP CAPACITOR	CC 0007.7423.00	PHILIPS_CO	2222 863 18182	
C781	CC 1,8NF+-1% 50V NPO 1206 CERAMIC CHIP CAPACITOR	CC 0007.7423.00	PHILIPS_CO	2222 863 18182	
C782	CE 4,7UF +-10% 25V 7343 TANTALUM SMD-CAPACITOR	CE 0007.7230.00	SPRAGUE	293D475X9035D2T	
C784	CC 100PF+-1%50V NPO 1206 CERAMIC CHIP CAPACITOR	CC 0099.8415.00	MURATA	GRM42-6COG 101F 50PT	
C786	CC 10NF+-10%50V X7R 1206 CERAMIC CHIP CAPACITOR	CC 0099.8521.00	MURATA	GRM42-6X7R103K 50PT	
C787	CC 100NF+-10%50V X7R 1206 CERAMIC CHIP CAPACITOR	CC 0007.5237.00	PHILIPS_CO	2238 581 15649	
C788	CC 100NF+-10%50V X7R 1206 CERAMIC CHIP CAPACITOR	CC 0007.5237.00	PHILIPS_CO	2238 581 15649	
C789	CE 47UF +-10% 10V 7343 TANTALUM SMD-CAPACITOR	CE 0007.7300.00	SPRAGUE	293D X9 010 D2T	
..791					
C792	CE 10UF+-20%35V 7343 SMD-TANTALUM CAPACITOR	1078.3291.00	SIEMENS	B45197-A6106-M40*	
C793	CE 10UF+-20%35V 7343 SMD-TANTALUM CAPACITOR	1078.3291.00	SIEMENS	B45197-A6106-M40*	
C800	CC 5,6PF+-0,25 50V NPO1206 CERAMIC CHIP CAPACITOR	CC 0007.8220.00	MURATA	GRM42-6COG 5R6 C50PT	
C830	CK 330NF+-5% 25V PPS 2824 SMD-FILM-CAPACITOR	0010.6660.00	PHILIPS_CO	2222 394 29334	

MENP5	413 3PUA	ÄI	Datum Date	Schaltteilliste für Parts list for	Sachnummer Stock No.	Blatt-Nr. Page
		31	16.09.97	EE SYNTHESIZER SYNTHESIZER	1062.6409.01 SA	5+

095.0028-0693

Kennz. Comp. No.	Benennung Designation	Sachnummer Stock No.	Hersteller Manufacturer	Bezeichnung Designation	enthalten in contained in
C840	CC 4,7PF+-0,25 50VNP01206 CERAMIC CHIP CAPACITOR	CC 0007.8213.00	MURATA	GRM42-6COG 4R7C 50PT	
C841	CC 100NF+-10%50V X7R 1206 CERAMIC CHIP CAPACITOR	CC 0007.5237.00	PHILIPS_CO	2238 581 15649	
C842	CC 15PF+-1% 50V NPO 1206 CERAMIC CHIP CAPACITOR	CC 0099.8750.00	MURATA	GRM42-6COG 150F 50PT	
C843	CC 3,3PF+-0,25 50VNP01206 CERAMIC CHIP CAPACITOR	CC 0007.8194.00	MURATA	GRM42-6COG 3R3 C50PT	
C844	CC 3,3PF+-0,25 50VNP01206 CERAMIC CHIP CAPACITOR	CC 0007.8194.00	MURATA	GRM42-6COG 3R3 C50PT	
C845	CC 5,6PF+-0,25 50VNP01206 CERAMIC CHIP CAPACITOR NICHT BESTUECKT NOT FITTED	CC 0007.8220.00	MURATA	GRM42-6COG 5R6 C50PT	
C846	CC 100PF+-1%50V NPO 1206 CERAMIC CHIP CAPACITOR	CC 0099.8415.00	MURATA	GRM42-6COG 101F 50PT	
C850	CC 22PF+-1%50V NPO 1206 CERAMIC CHIP CAPACITOR	CC 0099.8396.00	MURATA	GRM42-6COG 220F 50PT	
C860	CE 220UF+-20%10V RM2,5 ELECTROLYTIC CAPACITOR	CE 0008.7927.00	PANASONIC	ECA-1AFG221I	
C861	CE 220UF+-20%10V RM2,5 ELECTROLYTIC CAPACITOR	CE 0008.7927.00	PANASONIC	ECA-1AFG221I	
C862	CC 1,2NF+-1% 50V NPO 1206 CERAMIC CHIP CAPACITOR	CC 0007.7400.00	PHILIPS_CO	2222 863 18122	
C865	CE 2,2UF +-10% 25V 6032 TANTALUM SMD-CAPACITOR	CE 0007.7223.00	KEMET	T491 C225 K 025 AS	
C866	CE 2,2UF +-10% 25V 6032 TANTALUM SMD-CAPACITOR	CE 0007.7223.00	KEMET	T491 C225 K 025 AS	
C870	CC 1UF+-10% 50V X7R 2220 CERAMIC CAPACITOR	CC 0520.6873.00	AVX	2220 5C 105 KAT00F	
C871	CC 1UF+-10% 50V X7R 2220 CERAMIC CAPACITOR	CC 0520.6873.00	AVX	2220 5C 105 KAT00F	
C884	CE 47UF +-10% 10V 7343 TANTALUM SMD-CAPACITOR	CE 0007.7300.00	SPRAGUE	293D X9 010 D2T	
C885	CE 47UF +-10% 10V 7343 TANTALUM SMD-CAPACITOR	CE 0007.7300.00	SPRAGUE	293D X9 010 D2T	
C890	CE 100UF+-20%25V RM2.5 ELECTOLYTIC CAPACITOR	CE 0008.7891.00	PANASONIC	ECA-1EFG101I	
C911	CC 150PF+-1%50V NPO 1206 CERAMIC CHIP CAPACITOR NICHT BESTUECKT NOT FITTED	CC 0099.8509.00	PHILIPS_CO	2238 863 18151	
C913	CC 3,9NF+-1% 50V NPO 1206 SMD-CERAMIC CAPACITOR	0010.2987.00	MURATA	GRM42-6COG392F50PT	
C940	CC 470PF+-1%50V NPO 1206 CERAMIC CHIP CAPACITOR NUR VAR/ONLY MOD: 02	CC 0099.8515.00	PHILIPS_CO	2238 863 18471	
C941	CC 820PF+-1% 50V NPO 1206 CERAMIC CHIP CAPACITOR	CC 0007.7381.00	PHILIPS_CO	2222 863 18821	
C942	CC 820PF+-1% 50V NPO 1206 CERAMIC CHIP CAPACITOR	CC 0007.7381.00	PHILIPS_CO	2222 863 18821	
C942	CC 5,6PF+-0,25 50VNP01206 CERAMIC CHIP CAPACITOR	CC 0007.8220.00	MURATA	GRM42-6COG 5R6 C50PT	
C949	CC 82PF+-1%50V NPO 1206 CERAMIC CHIP CAPACITOR	CC 0099.8821.00	MURATA	GRM42-6COG 820F 50PT	
C950	CC 1,2NF+-1% 50V NPO 1206 CERAMIC CHIP CAPACITOR	CC 0007.7400.00	PHILIPS_CO	2222 863 18122	
C951	CC 270PF+-1%50V NPO 1206 CERAMIC CHIP CAPACITOR	CC 0099.8867.00	PHILIPS_CO	2222 863 18271	
C953	CC 820PF+-1% 50V NPO 1206 CERAMIC CHIP CAPACITOR	CC 0007.7381.00	PHILIPS_CO	2222 863 18821	
C954	CE 47UF +-10% 10V 7343 TANTALUM SMD-CAPACITOR	CE 0007.7300.00	SPRAGUE	293D X9 010 D2T	
C959	CC 68PF+-1%50V NPO 1206 CERAMIC CHIP CAPACITOR	CC 0099.8815.00	MURATA	GRM42-6COG 680F 50PT	
C960	CC 8,2PF+-0,25 50VNP01206 CERAMIC CHIP CAPACITOR NICHT BESTUECKT NOT FITTED	CC 0007.8242.00	MURATA	GRM42-6COG 8R2 C50PT	
C962	CC 100NF+-10%50V X7R 1206 CERAMIC CHIP CAPACITOR	CC 0007.5237.00	PHILIPS_CO	2238 581 15649	
C980	CE 47UF +-10% 10V 7343 TANTALUM SMD-CAPACITOR	CE 0007.7300.00	SPRAGUE	293D X9 010 D2T	
C989	CC 100NF+-10%50V X7R 1206 CERAMIC CHIP CAPACITOR	CC 0007.5237.00	PHILIPS_CO	2238 581 15649	
C990	CC 100NF+-10%50V X7R 1206 CERAMIC CHIP CAPACITOR	CC 0007.5237.00	PHILIPS_CO	2238 581 15649	

F

MENP5	413 3PUA	ÄI	Datum Date	Schaltteilliste für Parts list for	Sachnummer Stock No.	Blatt-Nr. Page
	31	16.09.97	EE SYNTHESIZER SYNTHESIZER	1062.6409.01 SA	6+	

Für diese Unterlage behalten
wir uns alle Rechte vor.

Für diese Unterlage behalten
wir uns alle Rechte vor.

Kennz. Comp. No.	Benennung Designation	Sachnummer Stock No.	Hersteller Manufacturer	Bezeichnung Designation	enthalten in contained in
C995	CE 2,2UF +-10% 25V 6032 TANTALUM SMD-CAPACITOR	CE 0007.7223.00	KEMET	T491 C225 K 025 AS	
D20	BD REF01CS 10V 20MA VREF VOLTAGE REFERENCE	1002.5129.00	PMI	REF01C(S)	
D65	BG L5A8611 FRACSYN2 ASIC IC GATEARRAY	1043.9493.00	LSI_LOGIC	R&S.S.NR.	
D110	BL PC74HC4094T 8ST.BUSREG BUS REGISTER	BL 0804.0977.00	PHILIPS_SE	(PC)74HC4094(D/T)	
D115	BL PC74HC4051T 8CH.AN.MUX 8CHANNEL ANAL.MULTIPLEXER	BL 0007.3592.00	PHILIPS_SE	(PC)74HC4051(D/T)	
D125	BL PC74HC132T 4XSCHMITT T QUAD 2-INP NAND SCHMITT	BL 0520.7811.00	PHILIPS_SE	(PC)74HC132(D/T)	
D200	BL 74AC005C 4X2IN NAND QUAD NAND GATTER	BL 0820.3477.00	NSC	74AC00(SC)	
D205	BL PC74HC390T 2XDEC.CNT DUAL DECADE COUNTER	BL 0007.5043.00	PHILIPS_SE	(PC)74HC390(D/T)	
D210	BL PC74HC74T 2XD-FF DUAL D-TYPE FLIPFLOP	BL 0007.3505.00	PHILIPS_SE	(PC)74HC74(D/T)	
D215	BS DG419DY 1XUM ANALOGSCH ANALOG SWITCH	0746.0322.00	SILICONIX	DG419DY	
D220	BJ DAC8143 1X12B-DAC 12B SERIAL D/A-CONVERTER	1012.9510.00	PMI	DAC8143FS	
D255	BL 74AC74SC 2XD-FLIPFL DUAL D-TYPE FLIPF	BL 0820.3602.00	NSC	74AC74(SC)	
D510	BL UPB581C 2:1 PRESC IC PRESCALERDIVIDER	0840.6113.00	NEC	(UP)B581C	
D520	BL UPB582C 4:1 PRESC IC PRESCALER	0820.3390.00	NEC	(UP)B582C	
D585	BL PC74HC4094T 8ST.BUSREG BUS REGISTER	BL 0804.0977.00	PHILIPS_SE	(PC)74HC4094(D/T)	
D620	BL MC12093D 2/4/8 PRESC IC PROGR PRESCALER	1062.6438.00	MOTOROLA	12093(D)	
D630	BL MC12093D 2/4/8 PRESC IC PROGR PRESCALER	1062.6438.00	MOTOROLA	12093(D)	
D640	BL 74FOOD 4X2IN NAND GATE QUAD 2INPUT NAND GATE	BL 0007.3628.00	PHILIPS_SE	(N)74FOO(D)	
D655	BL 74ACT74SC 2XRSFLIPFLOP IC DUAL D-FLIPFLOP	BL 0008.0680.00	HARRIS	(CD74)ACT74(M)	
D660	BL PC74HC4094T 8ST.BUSREG BUS REGISTER	BL 0804.0977.00	PHILIPS_SE	(PC)74HC4094(D/T)	
D665	BL PC74HC4094T 8ST.BUSREG BUS REGISTER	BL 0804.0977.00	PHILIPS_SE	(PC)74HC4094(D/T)	
D670	BL PC74HC4094T 8ST.BUSREG BUS REGISTER	BL 0804.0977.00	PHILIPS_SE	(PC)74HC4094(D/T)	
D700	BL 74AC74SC 2XD-FLIPFL DUAL D-TYPE FLIPF	BL 0820.3602.00	NSC	74AC74(SC)	
D710	BS DG419DY 1XUM ANALOGSCH ANALOG SWITCH	0746.0322.00	SILICONIX	DG419DY	
D720	BL PC74HC4051T 8CH.AN.MUX 8CHANNEL ANAL.MULTIPLEXER	BL 0007.3592.00	PHILIPS_SE	(PC)74HC4051(D/T)	
D800	BS DG413DY 2A2R ANALOGSCH QUAD ANALOG CMOS SWITCH	1004.7058.00	SILICONIX	DG413DY	
D820	BS DG419DY 1XUM ANALOGSCH ANALOG SWITCH	0746.0322.00	SILICONIX	DG419DY	
D840	BJ DAC8143 1X12B-DAC 12B SERIAL D/A-CONVERTER	1012.9510.00	PMI	DAC8143FS	
D855	BL PC74HC4094T 8ST.BUSREG BUS REGISTER	BL 0804.0977.00	PHILIPS_SE	(PC)74HC4094(D/T)	
D870	BL PC74HCT123T 2XMONOFLOP DUAL MULTIVIBRATOR	BL 0007.6333.00	PHILIPS_SE	(PC)74HCT123(D/T)	
D950	BL 74AC74SC 2XD-FLIPFL DUAL D-TYPE FLIPF	BL 0820.3602.00	NSC	74AC74(SC)	
D960	BL PC74HC4051T 8CH.AN.MUX 8CHANNEL ANAL.MULTIPLEXER	BL 0007.3592.00	PHILIPS_SE	(PC)74HC4051(D/T)	
D965	BS SD5400CY 4X ANALOGSCH QUAD ANALOG SWITCH	0351.0000.00	SILICONIX	SD5400CY	
K240	SR 5V 500 OHM 1X1 SIL RELAY 5V SIL	1012.9604.00	HAMLIN	HE3621A0500	
K910	SR 5V 500 OHM 1X1 SIL RELAY 5V SIL	1012.9604.00	HAMLIN	HE3621A0500	
L1	LD 10UH 10% 0,18A 1210 SMD-INDUCTOR	LD 0007.9255.00	SIEMENS	B82422-A1103-K100	
L2	LD 10UH 10% 0,18A 1210 SMD-INDUCTOR	LD 0007.9255.00	SIEMENS	B82422-A1103-K100	

MENP5

413 3PUA

Äi

Datum
Date

Schaltteilliste für
Parts list for

Sachnummer
Stock No.

Blatt-Nr.
Page



ROHDE & SCHWARZ

31

16.09.97

EE SYNTHESIZER
SYNTHESIZER

1062.6409.01 SA

7+

095.0028-0893

Kennz. Comp. No.	Benennung Designation	Sachnummer Stock No.	Hersteller Manufacturer	Bezeichnung Designation	enthalten in contained in
L3	LD 10UH BEI 0,81A 0,660HM CHOKE	LD 0026.4126.00	DALE	IM 6	
L4	LD 10UH BEI 0,81A 0,660HM CHOKE	LD 0026.4126.00	DALE	IM 6	
L5	LD 3,3UH BEI 1,63A0,160HM CHOKE	LD 0026.4061.00	DALE	IM 6	
L6	LD 10UH 10% 0,18A 1210 SMD-INDUCTOR NUR VAR/ONLY MOD: 02 43	LD 0007.9255.00	SIEMENS	B82422-A1103-K100	
L6	LD 1,20UH10%,180HMO,620A CHOKE NUR VAR/ONLY MOD: 04	LD 0067.2870.00	DALE	IM2	
L8	LD 10UH 10% 0,18A 1210 SMD-INDUCTOR	LD 0007.9255.00	SIEMENS	B82422-A1103-K100	
L9	LD 10UH 10% 0,18A 1210 SMD-INDUCTOR	LD 0007.9255.00	SIEMENS	B82422-A1103-K100	
L12	LD 10UH 10% 0,18A 1210 SMD-INDUCTOR	LD 0007.9255.00	SIEMENS	B82422-A1103-K100	
..15	LD 10UH 10% 0,18A 1210 SMD-INDUCTOR	LD 0007.9255.00	SIEMENS	B82422-A1103-K100	
L18	LD 10UH 10% 0,18A 1210 SMD-INDUCTOR	LD 0007.9255.00	SIEMENS	B82422-A1103-K100	
L19	LD 10UH 10% 0,18A 1210 SMD-INDUCTOR	LD 0007.9255.00	SIEMENS	B82422-A1103-K100	
L20	LD 10UH 10% 0,18A 1210 SMD-INDUCTOR	LD 0007.9255.00	SIEMENS	B82422-A1103-K100	
L22	LD 10UH 10% 0,18A 1210 SMD-INDUCTOR	LD 0007.9255.00	SIEMENS	B82422-A1103-K100	
L23	LD 10UH 10% 0,18A 1210 SMD-INDUCTOR	LD 0007.9255.00	SIEMENS	B82422-A1103-K100	
L28	LD 10UH 10% 0,18A 1210 SMD-INDUCTOR	LD 0007.9255.00	SIEMENS	B82422-A1103-K100	
L29	LD 1UH 10% 0,38A 1210 SMD-INDUCTOR	LD 6006.0130.00	SIEMENS	B82422-A1102-K100	
L33	LD 1UH 10% 0,38A 1210 SMD-INDUCTOR	LD 6006.0130.00	SIEMENS	B82422-A1102-K100	
L35	LD 10UH 10% 0,18A 1210 SMD-INDUCTOR	LD 0007.9255.00	SIEMENS	B82422-A1103-K100	
L200	LD 560NH 10% 0,15A 1210 CHOKE	4032.4388.00	SIEMENS	B82422-A3561-K100	
L202	LD 1UH 10% 0,38A 1210 SMD-INDUCTOR NUR VAR/ONLY MOD: 02 43	LD 6006.0130.00	SIEMENS	B82422-A1102-K100	
L202	RG 0-OHM WIDERSTAND-CHIP RESISTOR CHIP 0-OHM NUR VAR/ONLY MOD: 04	RG 0007.5108.00	DRALORIC	CR 1206	
L204	LD 1UH 10% 0,38A 1210 SMD-INDUCTOR NUR VAR/ONLY MOD: 02 43	LD 6006.0130.00	SIEMENS	B82422-A1102-K100	
L204	RG 0-OHM WIDERSTAND-CHIP RESISTOR CHIP 0-OHM NUR VAR/ONLY MOD: 04	RG 0007.5108.00	DRALORIC	CR 1206	
L227	LD 1,5UH 5% DR2 0,56A CHOKE	0067.3247.00	DELEVAN	1025-24	
L300	LD 220NH10%,4AOR5 1206 SMD-COIL 1206	1062.6515.00	STETTNER	5503 004 21	
L302	LD 470NH10%OR5 0,1A1206 SMD-MULTILAYER INDUCTOR	0007.9226.00	TOKO	MLF 3216 D R47 KL	
L306	LD 220NH 10% 0,28A 1210 SMD-INDUCTOR	LD 0520.7911.00	SIEMENS	B82422-A3221-K100	
L346	LD 32 NH SMD-ABGL.Q5,1H5 SMD-VHF-COIL	0008.9436.00	COMPONEX	E 558 CN-10 0020	
L400	LD 220NH10%,4AOR5 1206 SMD-COIL 1206	1062.6515.00	STETTNER	5503 004 21	
L402	LD 220NH10%,4AOR5 1206 SMD-COIL 1206	1062.6515.00	STETTNER	5503 004 21	
L404	LD 220NH10%,4AOR5 1206 SMD-COIL 1206	1062.6515.00	STETTNER	5503 004 21	
L406	LD 220NH10%,4AOR5 1206 SMD-COIL 1206	1062.6515.00	STETTNER	5503 004 21	
L430	LD 220NH10%,4AOR5 1206 SMD-COIL 1206	1062.6515.00	STETTNER	5503 004 21	
L432	LD 220NH10%,4AOR5 1206 SMD-COIL 1206	1062.6515.00	STETTNER	5503 004 21	
L434	LD 220NH10%,4AOR5 1206 SMD-COIL 1206	1062.6515.00	STETTNER	5503 004 21	
L436	LD 220NH10%,4AOR5 1206 SMD-COIL 1206	1062.6515.00	STETTNER	5503 004 21	
L492	LD 1UH 10% 0,38A 1210 SMD-INDUCTOR	LD 6006.0130.00	SIEMENS	B82422-A1102-K100	

MENP5	413 3PUA	Ät	Datum Date	Schaltlisten für Parts list for	Sachnummer Stock No.	Blatt-Nr. Page
	ROHDE & SCHWARZ	31	16.09.97	EE SYNTHESIZER SYNTHESIZER	1062.6409.01 SA	8+

Für diese Umbenennung benachrichtigen wir uns alle Rechte vor.

095.0026-0693

Für diese Unterlage behalten
wir uns alle Rechte vor.

Kennz. Comp. No.	Benennung Designation	Sachnummer Stock No.	Hersteller Manufacturer	Bezeichnung Designation	enthalten in contained in		
L494	LD 1UH 10% SMD-INDUCTOR	0,38A 1210	LD 6006.0130.00	SIEMENS	B82422-A1102-K100		
L500	LD 1UH 10% SMD-INDUCTOR	0,38A 1210	LD 6006.0130.00	SIEMENS	B82422-A1102-K100		
L502	LD 1UH 10% SMD-INDUCTOR	0,38A 1210	LD 6006.0130.00	SIEMENS	B82422-A1102-K100		
L505	LD 1UH 10% SMD-INDUCTOR	0,38A 1210	LD 6006.0130.00	SIEMENS	B82422-A1102-K100		
L506	LD 1UH 10% SMD-INDUCTOR	0,38A 1210	LD 6006.0130.00	SIEMENS	B82422-A1102-K100		
L507	LD 1UH 10% SMD-INDUCTOR	0,38A 1210	LD 6006.0130.00	SIEMENS	B82422-A1102-K100		
L515	LD 1UH 10% SMD-INDUCTOR	0,38A 1210	LD 6006.0130.00	SIEMENS	B82422-A1102-K100		
L516	LD 1UH 10% SMD-INDUCTOR	0,38A 1210	LD 6006.0130.00	SIEMENS	B82422-A1102-K100		
L525	LD 1UH 10% SMD-INDUCTOR	0,38A 1210	LD 6006.0130.00	SIEMENS	B82422-A1102-K100		
L530	LD 1UH 10% SMD-INDUCTOR	0,38A 1210	LD 6006.0130.00	SIEMENS	B82422-A1102-K100		
L550	LD 1UH 10% SMD-INDUCTOR	0,38A 1210	LD 6006.0130.00	SIEMENS	B82422-A1102-K100		
L551	LD 1UH 10% SMD-INDUCTOR	0,38A 1210	LD 6006.0130.00	SIEMENS	B82422-A1102-K100		
L570	LD 1UH 10% SMD-INDUCTOR	0,38A 1210	LD 6006.0130.00	SIEMENS	B82422-A1102-K100		
L571	LD 1UH 10% SMD-INDUCTOR	0,38A 1210	LD 6006.0130.00	SIEMENS	B82422-A1102-K100		
L600	LD 1UH 10% SMD-INDUCTOR	0,38A 1210	LD 6006.0130.00	SIEMENS	B82422-A1102-K100		
L610	LD 1UH 10% SMD-INDUCTOR	0,38A 1210	LD 6006.0130.00	SIEMENS	B82422-A1102-K100		
L621	LD 1UH 10% SMD-INDUCTOR	0,38A 1210	LD 6006.0130.00	SIEMENS	B82422-A1102-K100		
L631	LD 1UH 10% SMD-INDUCTOR	0,38A 1210	LD 6006.0130.00	SIEMENS	B82422-A1102-K100		
L645	LD 10UH 10% SMD-INDUCTOR	0,18A 1210	LD 0007.9255.00	SIEMENS	B82422-A1103-K100		
L655	LD 10UH 10% SMD-INDUCTOR	0,18A 1210	LD 0007.9255.00	SIEMENS	B82422-A1103-K100		
L695	LD 12NH 10% SMD-INDUCTOR	0,70A 1210	1002.4900.00	SIEMENS	B82422-A3120-K100		
L800	LD 33ONH 10% SMD-INDUCTOR	0,20A 1210	LD 0520.7534.00	SIEMENS	B82422-A3331-K100		
L801	LD 33ONH 10% SMD-INDUCTOR	0,20A 1210	LD 0520.7534.00	SIEMENS	B82422-A3331-K100		
N20	BO MC1458D 2X OPAMP OPERATION AMPLIFIER		0007.3763.00	SIGNETICS	MC1458(D)		
N100	BO LM2903D 2XLP COMPAR DUAL		0520.7734.00	SIGNETICS	LM2903(D)		
N105	BO LM2903D 2XLP COMPAR DUAL		0520.7734.00	SIGNETICS	LM2903(D)		
N110	BO LM2903D 2XLP COMPAR DUAL		0520.7734.00	SIGNETICS	LM2903(D)		
N200	EO 10.000000MHZ QUA-OSZ5V CRYSTAL OSZILLATOR VTCXO NUR VAR/ONLY MOD: 02 43		1036.4331.00	PHILIPS_CD	9922 515 00037		
N200	EO 10MHZ-QU.OSZ.OCXO 5V CRYSTAL OSZILLATOR OCXO NUR VAR/ONLY MOD: 04		1062.6680.00	MILLIREN	210-0618		
N220	BO TLO74ACD 4XFET OPAMP OPERATIONAL AMPLIFIER		0007.7823.00	TEXAS	TLO74A(CD)		
N250	BO NE5534D OPAMP OPERATIONAL AMPLIFIER		0815.7555.00	SIGNETICS	NE5534(D)		
N300	BM MSA0386 DC-2.4G MMIC BROAD-BAND AMPLIFIER		0848.4461.00	HEWLETT_PA	HPMA-0386		
N490	BM MSA0386 DC-2.4G MMIC BROAD-BAND AMPLIFIER		0848.4461.00	HEWLETT_PA	HPMA-0386		
N500	BM MAR6-SM DC-2.0G MMIC MICROWAVE MONOLITIC CIRC		6024.3666.00	MINI-CIRCU	MAR-6-SM		
N510	BM MSA0386 DC-2.4G MMIC BROAD-BAND AMPLIFIER		0848.4461.00	HEWLETT_PA	HPMA-0386		
N520	BM MSA0386 DC-2.4G MMIC BROAD-BAND AMPLIFIER		0848.4461.00	HEWLETT_PA	HPMA-0386		
N560	BM MSA0486 DC-3.2G MMIC BROADBAND AMPLIFIER		0846.4293.00	AVANTEK	MSA-0486		
MENP5	413 3PUA	ÄI	Datum Date	Schaltteilliste für Parts list for		Sachnummer Stock No.	Blatt-Nr. Page
	ROHDE & SCHWARZ	31	16.09.97	EE SYNTHESIZER SYNTHESIZER		1062.6409.01 SA	9+

095.0026-0693

Kennz. Comp. No.	Benennung Designation	Sachnummer Stock No.	Hersteller Manufacturer	Bezeichnung Designation	enthalten in contained in
N600	BM MSA0386 DC-2.4G MMIC BROAD-BAND AMPLIFIER	0848.4461.00	HEWLETT_PA	HPMA-0386	
N610	BM MSA0386 DC-2.4G MMIC BROAD-BAND AMPLIFIER	0848.4461.00	HEWLETT_PA	HPMA-0386	
N705	BO REF02CS VREF IC VOLTAGE REFERENCE	0009.6882.00	ANALOG_DEV	REF02CS	
N710	BO NE5534D OPAMP OPERATIONAL AMPLIFIER	0815.7555.00	SIGNETICS	NE5534(D)	
N720	BO NE5534D OPAMP OPERATIONAL AMPLIFIER	0815.7555.00	SIGNETICS	NE5534(D)	
N780	BO TLO72ACD 2XFET OPAMP OPERATIONAL AMPLIFIER	0803.1057.00	TEXAS	TL 072 ACDR	
N800	BO AD744KR FET OPAMP BIFET OPAMP	0854.1754.00	ANALOG_DEV	(AD)744KR	
N840	BO AD843KN FET OPAMP IC OPAMP	1039.1285.00	ANALOG_DEV	AD843KN	
N842	BO AD829JR 1XLOLN OPAMP IC OPAMP	1036.4254.00	ANALOG_DEV	AD829JR	
N845	BO AD744KR FET OPAMP BIFET OPAMP	0854.1754.00	ANALOG_DEV	(AD)744KR	
N850	BO NE5534D OPAMP OPERATIONAL AMPLIFIER	0815.7555.00	SIGNETICS	NE5534(D)	
N860	BO LM119J 2X COMPAR COMPARATOR	0007.5337.00	LINEAR_TEC	LM119J (AJ)	
N940	BO AD744KR FET OPAMP BIFET OPAMP	0854.1754.00	ANALOG_DEV	(AD)744KR	
N950	BO TLO74ACD 4XFET OPAMP OPERATIONAL AMPLIFIER	0007.7823.00	TEXAS	TLO74A(CD)	
N960	BO LM211D COMPAR COMPARATOR	0007.7869.00	SIGNETICS	LM211(D)	
P20	VL EINPRESSTIFT L=6,8 PIN	VL 0010.7250.00	AMP	1-928776-5	
P21	VL EINPRESSTIFT L=6,8 PIN	VL 0010.7250.00	AMP	1-928776-5	
P201 ..204	VL EINPRESSTIFT L=6,8 PIN	VL 0010.7250.00	AMP	1-928776-5	
P354	VL EINPRESSTIFT L=6,8 PIN	VL 0010.7250.00	AMP	1-928776-5	
P600	VL EINPRESSTIFT L=6,8 PIN	VL 0010.7250.00	AMP	1-928776-5	
P610	VL EINPRESSTIFT L=6,8 PIN	VL 0010.7250.00	AMP	1-928776-5	
P700	VL EINPRESSTIFT L=6,8 PIN	VL 0010.7250.00	AMP	1-928776-5	
P720	VL EINPRESSTIFT L=6,8 PIN	VL 0010.7250.00	AMP	1-928776-5	
P840	VL EINPRESSTIFT L=6,8 PIN	VL 0010.7250.00	AMP	1-928776-5	
R5	RD 2.4 W 1,5 OHM +-1% WIRE WOUND RESISTOR	RD 0067.9274.00	TEPRO	TS-2B	
R20	RS 0,25W10KOHM +-20% SMD POTENTIOMETER NICHT BESTUECKT NOT FITTED	RS 0007.9649.00	BOURNS	3314G-1-103	
R21	RG 22,1 OHM+-1%TK100 1206 RESISTOR CHIP	RG 0007.5489.00	ROEDERSTEI	DC2 22,10HM 1%TK100	
R22	RG 39,2KOHM+-1%TK100 1206 RESISTOR CHIP NICHT BESTUECKT NOT FITTED	RG 0007.5937.00	ROEDERSTEI	DC2 39,2KOHM 1%TK100	
R23	RG 10,0KOHM+-1%TK100 1206 RG CHIP RESISTOR	RG 0007.0793.00	ROEDERSTEI	DC2 10,0KOHM 1%TK100	
R24	RG 20,0KOHM+-1%TK100 1206 RESISTOR CHIP	RG 0007.5866.00	ROEDERSTEI	DC2 20,0KOHM 1%TK100	
R25	RG 10,0KOHM+-1%TK100 1206 RG CHIP RESISTOR	RG 0007.0793.00	ROEDERSTEI	DC2 10,0KOHM 1%TK100	
R26	RG 9,09KOH+-0,1%TK25 1206 SMD-RESISTOR EIA1206	0009.8904.00	MIKRO-TEK-	CMF 1206	
R27	RG 10,0KOH+-0,1%TK25 1206 SMD-RESISTOR	0009.7666.00	MIKRO-TEK-	CMF 1206	
R28	RG 100 OHM+-1%TK100 1206 CHIP RESISTOR	RG 0006.8884.00	ROEDERSTEI	DC2 100OHM 1%TK100	
R29	RG 1,0 KO +-1%TK100 1206 CHIP RESISTOR	RG 0006.7271.00	ROEDERSTEI	DC2 1,0KOHM 1%TK100	
R30	RG 47,5 OHM+-1%TK100 1206 RESISTOR CHIP	RG 0007.5566.00	ROEDERSTEI	DC2 47,5OHM 1%TK100	

Für diese Unterlage bezahlen wir uns alle Rechte vor.

095.0026-0693

MENP5	413 3PUA	Ät	Datum Date	Schaltteilliste für Parts list for	Sachnummer Stock No.	Blatt-Nr. Page
	ROHDE & SCHWARZ	31	16.09.97	EE SYNTHESIZER SYNTHESIZER	1062.6409.01 SA	10+

Für diese Unterlage behalten
wir uns alle Rechte vor.

Kennz. Comp. No.	Benennung Designation	Sachnummer Stock No.	Hersteller Manufacturer	Bezeichnung Designation	enthalten in contained in
R31	RG 10,0 OHM+-1%TK100 1206 CHIP -RESISTOR	RG 0006.8649.00	DRALORIC	CR(B) 1206...	
R100	RG 22,1 OHM+-1%TK100 1206 RESISTOR CHIP	RG 0007.5489.00	ROEDERSTEI	DC2 22,1OHM 1%TK100	
R110	RG 47,5 OHM+-1%TK100 1206 RESISTOR CHIP	RG 0007.5566.00	ROEDERSTEI	DC2 47,5OHM 1%TK100	
R111	RG 100 OHM+-1%TK100 1206 CHIP RESISTOR	RG 0006.8884.00	ROEDERSTEI	DC2 100OHM 1%TK100	
R112	RG 47,5 OHM+-1%TK100 1206 RESISTOR CHIP	RG 0007.5566.00	ROEDERSTEI	DC2 47,5OHM 1%TK100	
R113	RG 100 OHM+-1%TK100 1206 CHIP RESISTOR	RG 0006.8884.00	ROEDERSTEI	DC2 100OHM 1%TK100	
R114	RG 47,5 OHM+-1%TK100 1206 RESISTOR CHIP	RG 0007.5566.00	ROEDERSTEI	DC2 47,5OHM 1%TK100	
R115	RG 475 OHM+-1%TK100 1206 RESISTOR CHIP	RG 0007.5695.00	ROEDERSTEI	DC2 475OHM 1%TK100	
R116	RG 47,5 OHM+-1%TK100 1206 RESISTOR CHIP	RG 0007.5566.00	ROEDERSTEI	DC2 47,5OHM 1%TK100	
R117	RG 475 OHM+-1%TK100 1206 RESISTOR CHIP	RG 0007.5695.00	ROEDERSTEI	DC2 475OHM 1%TK100	
R118	RG 475 OHM+-1%TK100 1206 RESISTOR CHIP	RG 0007.5695.00	ROEDERSTEI	DC2 475OHM 1%TK100	
R119	RG 47,5 OHM+-1%TK100 1206 RESISTOR CHIP	RG 0007.5566.00	ROEDERSTEI	DC2 47,5OHM 1%TK100	
R120	RG 10,0 OHM+-1%TK100 1206 CHIP -RESISTOR	RG 0006.8649.00	DRALORIC	CR(B) 1206...	
R125	RG 4,75KOHM+-1%TK100 1206 RESISTOR CHIP	RG 0007.5820.00	ROEDERSTEI	DC2 4,75KOHM 1%TK100	
R142	RG 4,75KOHM+-1%TK100 1206 RESISTOR CHIP	RG 0007.5820.00	ROEDERSTEI	DC2 4,75KOHM 1%TK100	
R144	RG 15,0KOHM+-1%TK100 1206 RESISTOR CHIP	RG 0007.5843.00	ROEDERSTEI	DC2 15,0KOHM 1%TK100	
R145	RG 4,75KOHM+-1%TK100 1206 RESISTOR CHIP	RG 0007.5820.00	ROEDERSTEI	DC2 4,75KOHM 1%TK100	
R146	RG 10,0KOHM+-1%TK100 1206 RG CHIP RESISTOR	RG 0007.0793.00	ROEDERSTEI	DC2 10,0KOHM 1%TK100	
R150	RG 12,1KOHM+-1%TK100 1206 CHIP RESISTOR	RG 0007.0841.00	ROEDERSTEI	DC2 12,1KOHM 1%TK100	
R152	RG 1,5 KOHM+-1%TK100 1206 RESISTOR CHIP	RG 0007.5714.00	ROEDERSTEI	DC2 1,5KOHM 1%TK100	
R154	RG 0-OHM WIDERSTAND-CHIP RESISTOR CHIP 0-OHM	RG 0007.5108.00	DRALORIC	CR 1206	
R156	RG 11,0KOHM+-1%TK100 1206 CHIP RESISTOR	RG 0007.0806.00	ROEDERSTEI	DC2 11,0KOHM 1%TK100	
R158	RG 3,57KOHM+-1%TK100 1206 RESISTOR CHIP	RG 0007.5795.00	ROEDERSTEI	DC2 3,57KOHM 1%TK100	
R160	RG 392 OHM+-1%TK100 1206 RESISTOR CHIP	RG 0007.5672.00	ROEDERSTEI	DC2 392OHM 1%TK100	
R162	RG 100,0KOH+-1%TK100 1206 CHIP RESISTOR	RG 0007.1948.00	ROEDERSTEI	DC2 100KOHM 1%TK100	
R164	RG 10,0KOHM+-1%TK100 1206 RG CHIP RESISTOR	RG 0007.0793.00	ROEDERSTEI	DC2 10,0KOHM 1%TK100	
R166	RG 27,4KOHM+-1%TK100 1206 RESISTOR CHIP	RG 0007.5895.00	ROEDERSTEI	DC2 27,4KOHM 1%TK100	
R167	RG 681 OHM+-1%TK100 1206 CHIP RESISTOR	RG 0006.9080.00	ROEDERSTEI	DC2 681OHM 1%TK100	
R170	RG 4,75KOHM+-1%TK100 1206 RESISTOR CHIP	RG 0007.5820.00	ROEDERSTEI	DC2 4,75KOHM 1%TK100	
R172	RG 4,75KOHM+-1%TK100 1206 RESISTOR CHIP	RG 0007.5820.00	ROEDERSTEI	DC2 4,75KOHM 1%TK100	
R174	RG 4,75KOHM+-1%TK100 1206 RESISTOR CHIP	RG 0007.5820.00	ROEDERSTEI	DC2 4,75KOHM 1%TK100	
R178	RG 47,5KOHM+-1%TK100 1206 RESISTOR CHIP	RG 0007.5950.00	ROEDERSTEI	DC2 47,5KOHM 1%TK100	
R180	RG 47,5 OHM+-1%TK100 1206 RESISTOR CHIP	RG 0007.5566.00	ROEDERSTEI	DC2 47,5OHM 1%TK100	
R181	RG 475 OHM+-1%TK100 1206 RESISTOR CHIP	RG 0007.5695.00	ROEDERSTEI	DC2 475OHM 1%TK100	
R201	RG 10,0 OHM+-1%TK100 1206 CHIP -RESISTOR	RG 0006.8649.00	DRALORIC	CR(B) 1206...	
R202	RG 100 OHM+-1%TK100 1206 CHIP RESISTOR	RG 0006.8884.00	ROEDERSTEI	DC2 100OHM 1%TK100	
R204	RG 4,75KOHM+-1%TK100 1206 RESISTOR CHIP	RG 0007.5820.00	ROEDERSTEI	DC2 4,75KOHM 1%TK100	
R204	NUR VAR/ONLY MOD: 02 43 RG 332 OHM+-1%TK100 1206 RESISTOR CHIP NUR VAR/ONLY MOD: 04	RG 0007.5650.00	ROEDERSTEI	DC2 332OHM 1%TK100	

MENP5

413 3PUA

Äi

Datum
Date

Schaltteilliste für
Parts list for

Sachnummer
Stock No.

Blatt-Nr.
Page



ROHDE & SCHWARZ

31

16.09.97

EE SYNTHESIZER
SYNTHESIZER

1062.6409.01 SA

11+

Kennz. Comp. No.	Benennung Designation	Sachnummer Stock No.	Hersteller Manufacturer	Bezeichnung Designation	enthalten in contained in
R206	RG 3,92KOHM+-1%TK100 1206 RESISTOR CHIP	RG 0007.5808.00	RESISTA	DC2 3,92KOHM 1%TK100	
R207	RG 4,75KOHM+-1%TK100 1206 RESISTOR CHIP	RG 0007.5820.00	ROEDERSTEI	DC2 4,75KOHM 1%TK100	
R208	RG 10,0 OHM+-1%TK100 1206 CHIP -RESISTOR	RG 0006.8649.00	DRALORIC	CR(B) 1206...	
R209	RG 10,0 OHM+-1%TK100 1206 CHIP -RESISTOR	RG 0006.8649.00	DRALORIC	CR(B) 1206...	
R210	RG 221 OHM+-1%TK100 1206 RESISTOR CHIP	RG 0007.5614.00	ROEDERSTEI	DC2 221OHM 1%TK100	
R212	RG 475 OHM+-1%TK100 1206 RESISTOR CHIP	RG 0007.5695.00	ROEDERSTEI	DC2 475OHM 1%TK100	
R213	RG 10,0KOHM+-1%TK100 1206 RG CHIP RESISTOR	RG 0007.0793.00	ROEDERSTEI	DC2 10,0KOHM 1%TK100	
R214	RG 274 OHM+-1%TK100 1206 RESISTOR CHIP	RG 0007.5637.00	ROEDERSTEI	DC2 274OHM 1%TK100	
R215	RG 221 OHM+-1%TK100 1206 RESISTOR CHIP	RG 0007.5614.00	ROEDERSTEI	DC2 221OHM 1%TK100	
R216	RG 4,75KOHM+-1%TK100 1206 RESISTOR CHIP	RG 0007.5820.00	ROEDERSTEI	DC2 4,75KOHM 1%TK100	
R218	RG 2,21KOHM+-1%TK100 1206 RESISTOR CHIP	RG 0007.5743.00	ROEDERSTEI	DC2 2,21KOHM 1%TK100	
R219	RG 475 OHM+-1%TK100 1206 RESISTOR CHIP	RG 0007.5695.00	ROEDERSTEI	DC2 475OHM 1%TK100	
R220	RG 100 OHM+-1%TK100 1206 CHIP RESISTOR	RG 0006.8884.00	ROEDERSTEI	DC2 100OHM 1%TK100	
R221	RG 4,75KOHM+-1%TK100 1206 RESISTOR CHIP	RG 0007.5820.00	ROEDERSTEI	DC2 4,75KOHM 1%TK100	
R222	RG 10,0KOHM+-1%TK100 1206 RG CHIP RESISTOR	RG 0007.0793.00	ROEDERSTEI	DC2 10,0KOHM 1%TK100	
R223	RG 274 OHM+-1%TK100 1206 RESISTOR CHIP	RG 0007.5637.00	ROEDERSTEI	DC2 274OHM 1%TK100	
R224	RG 68,1 OHM+-1%TK100 1206 CHIP RESISTOR	RG 0006.8849.00	ROEDERSTEI	DC2 68,1OHM 1%TK100	
R225	RG 274 OHM+-1%TK100 1206 RESISTOR CHIP NUR VAR/ONLY MOD: 02 43	RG 0007.5637.00	ROEDERSTEI	DC2 274OHM 1%TK100	
R225	RG 274 OHM+-1%TK100 1206 RESISTOR CHIP NUR VAR/ONLY MOD: 04 NICHT BESTUECKT/NOT FITTED	RG 0007.5637.00	ROEDERSTEI	DC2 274OHM 1%TK100	
R226	RG 274 OHM+-1%TK100 1206 RESISTOR CHIP	RG 0007.5637.00	ROEDERSTEI	DC2 274OHM 1%TK100	
R227	RG 100 OHM+-1%TK100 1206 CHIP RESISTOR	RG 0006.8884.00	ROEDERSTEI	DC2 100OHM 1%TK100	
R228	RG 221 OHM+-1%TK100 1206 RESISTOR CHIP	RG 0007.5614.00	ROEDERSTEI	DC2 221OHM 1%TK100	
R229	RG 18,2KOHM+-1%TK100 1206 RESISTOR CHIP	RG 0007.5850.00	ROEDERSTEI	DC2 18,2KOHM 1%TK100	
R230	RG 20,0KOHM+-1%TK100 1206 RESISTOR CHIP	RG 0007.5866.00	ROEDERSTEI	DC2 20,0KOHM 1%TK100	
R232	RG 10,0KOHM+-1%TK100 1206 RG CHIP RESISTOR	RG 0007.0793.00	ROEDERSTEI	DC2 10,0KOHM 1%TK100	
R234	RG 2,21KOHM+-1%TK100 1206 RESISTOR CHIP	RG 0007.5743.00	ROEDERSTEI	DC2 2,21KOHM 1%TK100	
R236	RG 150 OHM+-1%TK100 1206 RESISTOR CHIP NUR VAR/ONLY MOD: 02	RG 0007.5589.00	ROEDERSTEI	DC2 150OHM 1%TK100	
R236	RG 150R +-1% TK200 0603 SMD-RESISTOR EIA0603 NUR VAR/ONLY MOD: 04	0009.6947.00	ROEDERSTEI	D11 0603OH	
R238	RG 22,1KOHM+-1%TK100 1206 RESISTOR CHIP	RG 0007.5872.00	ROEDERSTEI	DC2 22,1KOHM 1%TK100	
R239	RG 10,0 OHM+-1%TK100 1206 CHIP -RESISTOR	RG 0006.8649.00	DRALORIC	CR(B) 1206...	
R240	RG 274 OHM+-1%TK100 1206 RESISTOR CHIP	RG 0007.5637.00	ROEDERSTEI	DC2 274OHM 1%TK100	
R241	RG 4,75KOHM+-1%TK100 1206 RESISTOR CHIP	RG 0007.5820.00	ROEDERSTEI	DC2 4,75KOHM 1%TK100	
R242	RG 4,75KOHM+-1%TK100 1206 RESISTOR CHIP	RG 0007.5820.00	ROEDERSTEI	DC2 4,75KOHM 1%TK100	
R243	RG 332 KOHM+-1%TK100 1206 RESISTOR CHIP	RG 0007.6033.00	ROEDERSTEI	DC2 332KOHM 1%TK100	
R245	RG 8,2MOHM+-5%TK200 1206 CHIP RESISTOR	0008.0645.00	ROEDERSTEI		
R246	RG 8,2MOHM+-5%TK200 1206 CHIP RESISTOR	0008.0645.00	ROEDERSTEI		
R247	RG 221 OHM+-1%TK100 1206 RESISTOR CHIP	RG 0007.5614.00	ROEDERSTEI	DC2 221OHM 1%TK100	

MENP5	413 3PUA	Ai	Datum - Date	Schaffteilliste für Parts list for	Sachnummer Stock No.	Blatt-Nr. Page
		31	16.09.97	EE SYNTHESIZER SYNTHESIZER	1062.6409.01 SA	12+

In diese Unterlage übernommen
Wir uns alle Rechte vor.

095.0028-0893

Für diese Unterlage behalten
wir uns alle Rechte vor.

Kennz. Comp. No.	Benennung Designation	Sachnummer Stock No.	Hersteller Manufacturer	Bezeichnung Designation	enthalten in contained in
R248	RG 332 KOHM+-1%TK100 1206 RESISTOR CHIP	RG 0007.6033.00	ROEDERSTEI	DC2 332KOHM 1%TK100	
R251	RG 4,75KOHM+-1%TK100 1206 RESISTOR CHIP	RG 0007.5820.00	ROEDERSTEI	DC2 4,75KOHM 1%TK100	
R253	RG 4,75KOHM+-1%TK100 1206 RESISTOR CHIP	RG 0007.5820.00	ROEDERSTEI	DC2 4,75KOHM 1%TK100	
R255	RG 4,75KOHM+-1%TK100 1206 RESISTOR CHIP	RG 0007.5820.00	ROEDERSTEI	DC2 4,75KOHM 1%TK100	
R258	RG 6,80KOH+-0,1%TK25 1206 SMD-RESISTOR EIA1206	0009.8891.00	MIKRO-TEK-	CMF 1206	
R260	RG 3,32KOHM+-1%TK100 1206 RESISTOR CHIP	RG 0007.5789.00	ROEDERSTEI	DC2 3,32KOHM 1%TK100	
R264	RG 6,80KOH+-0,1%TK25 1206 SMD-RESISTOR EIA1206	0009.8891.00	MIKRO-TEK-	CMF 1206	
R266	RG 1,0 KO +-1%TK100 1206 CHIP RESISTOR	RG 0006.7271.00	ROEDERSTEI	DC2 1,0KOHM 1%TK100	
R267	RG 1,0 KO +-1%TK100 1206 CHIP RESISTOR	RG 0006.7271.00	ROEDERSTEI	DC2 1,0KOHM 1%TK100	
R269	RG 1,0 KO +-1%TK100 1206 CHIP RESISTOR	RG 0006.7271.00	ROEDERSTEI	DC2 1,0KOHM 1%TK100	
R270	RG 1,0 KO +-1%TK100 1206 CHIP RESISTOR	RG 0006.7271.00	ROEDERSTEI	DC2 1,0KOHM 1%TK100	
R276	RG 4,75KOHM+-1%TK100 1206 RESISTOR CHIP	RG 0007.5820.00	ROEDERSTEI	DC2 4,75KOHM 1%TK100	
R277	RG 4,75KOHM+-1%TK100 1206 RESISTOR CHIP	RG 0007.5820.00	ROEDERSTEI	DC2 4,75KOHM 1%TK100	
R278	RG 221 OHM+-1%TK100 1206 RESISTOR CHIP	RG 0007.5614.00	ROEDERSTEI	DC2 221OHM 1%TK100	
R280	RG 6,81KOHM+-1%TK100 1206 CHIP RESISTOR	RG 0007.0758.00	ROEDERSTEI	DC2 6,81KOHM 1%TK100	
R281	RG 8,25KOHM+-1%TK100 1206 CHIP RESISTOR	RG 0007.0770.00	ROEDERSTEI	DC2 8,25KOHM 1%TK100	
R282	RG 6,81KOHM+-1%TK100 1206 CHIP RESISTOR	RG 0007.0758.00	ROEDERSTEI	DC2 6,81KOHM 1%TK100	
R283	RG 8,25KOHM+-1%TK100 1206 CHIP RESISTOR	RG 0007.0770.00	ROEDERSTEI	DC2 8,25KOHM 1%TK100	
R284	RG 1,0 KO +-1%TK100 1206 CHIP RESISTOR	RG 0006.7271.00	ROEDERSTEI	DC2 1,0KOHM 1%TK100	
R285	RG 1,0 KO +-1%TK100 1206 CHIP RESISTOR	RG 0006.7271.00	ROEDERSTEI	DC2 1,0KOHM 1%TK100	
R286	RG 7,5KOHM+-1%TK100 1206 RG CHIP RESISTOR	RG 0007.0764.00	ROEDERSTEI	DC2 7,50KOHM 1%TK100	
R287	RG 30,1KOHM+-1%TK100 1206 RESISTOR CHIP	RG 0007.5908.00	ROEDERSTEI	DC2 30,1KOHM 1%TK100	
R288	RG 100,0KOH+-1%TK100 1206 CHIP RESISTOR	RG 0007.1948.00	ROEDERSTEI	DC2 100KOHM 1%TK100	
R289	RG 1,0 KO +-1%TK100 1206 CHIP RESISTOR	RG 0006.7271.00	ROEDERSTEI	DC2 1,0KOHM 1%TK100	
R290	RG 10,0 OHM+-1%TK100 1206 CHIP -RESISTOR	RG 0006.8649.00	DRALORIC	CR(B) 1206...	
R291	RG 22,1 OHM+-1%TK100 1206 RESISTOR CHIP	RG 0007.5489.00	ROEDERSTEI	DC2 22,1OHM 1%TK100	
R302	RG 0,05W 56R +-1% 0805 RESISTOR	RG 0007.8971.00	HONEST JAP	MR 08 M 56R 1% 0805	
R304	RG 1,82KOHM+-1%TK100 1206 RESISTOR CHIP	RG 0007.5720.00	ROEDERSTEI	DC2 1,82KOHM 1%TK100	
R306	RG 1,82KOHM+-1%TK100 1206 RESISTOR CHIP	RG 0007.5720.00	ROEDERSTEI	DC2 1,82KOHM 1%TK100	
R308	RG 1,82KOHM+-1%TK100 1206 RESISTOR CHIP	RG 0007.5720.00	ROEDERSTEI	DC2 1,82KOHM 1%TK100	
R310	RG 200 OHM+-1%TK100 1206 RESISTOR CHIP	RG 0007.5608.00	ROEDERSTEI	DC2 200OHM 1%TK100	
R312	RG 4,75KOHM+-1%TK100 1206 RESISTOR CHIP	RG 0007.5820.00	ROEDERSTEI	DC2 4,75KOHM 1%TK100	
R314	RG 221 OHM+-1%TK100 1206 RESISTOR CHIP	RG 0007.5614.00	ROEDERSTEI	DC2 221OHM 1%TK100	
R316	RG 68,1 OHM+-1%TK100 1206 CHIP RESISTOR	RG 0006.8849.00	ROEDERSTEI	DC2 68,1OHM 1%TK100	
R324	RG 182 OHM+-1%TK100 1206 RESISTOR CHIP	RG 0007.5595.00	ROEDERSTEI	DC2 182OHM 1%TK100	
R326	RG 24,3 OHM+-1%TK100 1206 RESISTOR CHIP	RG 0007.5495.00	ROEDERSTEI	DC2 24,3OHM 1%TK100	
R328	RG 150 OHM+-1%TK100 1206 RESISTOR CHIP NICHT BESTUECKT NOT FITTED	RG 0007.5589.00	ROEDERSTEI	DC2 150OHM 1%TK100	
R330	RG 0-OHM WIDERSTAND-CHIP RESISTOR CHIP 0-OHM	RG 0007.5108.00	DRALORIC	CR 1206	

MENP5

413 3PUA

ÄI

Datum
Date

Schalttailliste für
Parts list for

Sachnummer
Stock No.

Blatt-Nr.
Page



ROHDE & SCHWARZ

31

16.09.97

EE SYNTHESIZER
SYNTHESIZER

1062.6409.01 SA

13+

Für diese Unterlage behalten wir uns alle Rechte vor.

Kennz. Comp. No.	Benennung Designation	Sachnummer Stock No.	Hersteller Manufacturer	Bezeichnung Designation	enthalten in contained in
R331	RG 100 OHM+-1%TK100 1206 CHIP RESISTOR	RG 0006.8884.00	ROEDERSTEI	DC2 100OHM 1%TK100	
R332	RG 47,5 OHM+-1%TK100 1206 RESISTOR CHIP	RG 0007.5566.00	ROEDERSTEI	DC2 47,5OHM 1%TK100	
R335	RG 68,1 OHM+-1%TK100 1206 CHIP RESISTOR	RG 0006.8849.00	ROEDERSTEI	DC2 68,1OHM 1%TK100	
R336	RG 182 OHM+-1%TK100 1206 RESISTOR CHIP	RG 0007.5595.00	ROEDERSTEI	DC2 182OHM 1%TK100	
R337	RG 2,21KOHM+-1%TK100 1206 RESISTOR CHIP	RG 0007.5743.00	ROEDERSTEI	DC2 2,21KOHM 1%TK100	
R338	RG 1,0 KO +-1%TK100 1206 CHIP RESISTOR	RG 0006.7271.00	ROEDERSTEI	DC2 1,0KOHM 1%TK100	
R339	RG 12,1KOHM+-1%TK100 1206 CHIP RESISTOR	RG 0007.0841.00	ROEDERSTEI	DC2 12,1KOHM 1%TK100	
R340	RG 100,0KOH+-1%TK100 1206 CHIP RESISTOR	RG 0007.1948.00	ROEDERSTEI	DC2 100KOHM 1%TK100	
R341	RG 10,0KOHM+-1%TK100 1206 RG CHIP RESISTOR	RG 0007.0793.00	ROEDERSTEI	DC2 10,0KOHM 1%TK100	
R342	RG 47,5KOHM+-1%TK100 1206 RESISTOR CHIP	RG 0007.5950.00	ROEDERSTEI	DC2 47,5KOHM 1%TK100	
R343	RG 3,01KOHM+-1%TK100 1206 RESISTOR CHIP	RG 0007.5772.00	ROEDERSTEI	DC2 3,01KOHM 1%TK100	
R344	RG 3,92KOHM+-1%TK100 1206 RESISTOR CHIP	RG 0007.5808.00	RESISTA	DC2 3,92KOHM 1%TK100	
R345	RG 12,1KOHM+-1%TK100 1206 CHIP RESISTOR	RG 0007.0841.00	ROEDERSTEI	DC2 12,1KOHM 1%TK100	
R346	RG 10,0 OHM+-1%TK100 1206 CHIP -RESISTOR	RG 0006.8649.00	DRALORIC	CR(B) 1206...	
R347	RG 100,0KOH+-1%TK100 1206 CHIP RESISTOR	RG 0007.1948.00	ROEDERSTEI	DC2 100KOHM 1%TK100	
R348	RG 10,0KOHM+-1%TK100 1206 RG CHIP RESISTOR	RG 0007.0793.00	ROEDERSTEI	DC2 10,0KOHM 1%TK100	
R361	RG 22,1 OHM+-1%TK100 1206 RESISTOR CHIP	RG 0007.5489.00	ROEDERSTEI	DC2 22,1OHM 1%TK100	
R370	RG 100 OHM+-1%TK100 1206 CHIP RESISTOR	RG 0006.8884.00	ROEDERSTEI	DC2 100OHM 1%TK100	
R371	RG 4,75KOHM+-1%TK100 1206 RESISTOR CHIP	RG 0007.5820.00	ROEDERSTEI	DC2 4,75KOHM 1%TK100	
R372	RG 221 OHM+-1%TK100 1206 RESISTOR CHIP	RG 0007.5614.00	ROEDERSTEI	DC2 221OHM 1%TK100	
R373	RG 10,0 OHM+-1%TK100 1206 CHIP -RESISTOR	RG 0006.8649.00	DRALORIC	CR(B) 1206...	
R375	RG 2,0 KOHM+-1%TK100 1206 RESISTOR CHIP	RG 0007.5737.00	ROEDERSTEI	DC2 2,0KOHM 1%TK100	
R400	RG 3,32OHM+-1%TK100 1206 CHIP-RESISTOR	RG 0007.8388.00	PHILIPS	RC 02	
R402	RG 3,32OHM+-1%TK100 1206 CHIP-RESISTOR	RG 0007.8388.00	PHILIPS	RC 02	
R404	RG 3,32OHM+-1%TK100 1206 CHIP-RESISTOR	RG 0007.8388.00	PHILIPS	RC 02	
R406	RG 3,32OHM+-1%TK100 1206 CHIP-RESISTOR	RG 0007.8388.00	PHILIPS	RC 02	
R408	RG 3,32OHM+-1%TK100 1206 CHIP-RESISTOR	RG 0007.8388.00	PHILIPS	RC 02	
R410	RG 0,05W 22R +-1% 0805 RESISTOR	RG 0007.8920.00	HONEST JAP	MR 08 M 22R 1% 0805	
R412	RG 1,82KOHM+-1%TK100 1206 RESISTOR CHIP	RG 0007.5720.00	ROEDERSTEI	DC2 1,82KOHM 1%TK100	
R414	RG 1,0 KO +-1%TK100 1206 CHIP RESISTOR	RG 0006.7271.00	ROEDERSTEI	DC2 1,0KOHM 1%TK100	
R416	RG 1,21KOHM+-1%TK100 1206 CHIP RESISTOR	RG 0006.9968.00	ROEDERSTEI	DC2 1,21KOHM 1%TK100	
R418	RG 1,0 KO +-1%TK100 1206 CHIP RESISTOR	RG 0006.7271.00	ROEDERSTEI	DC2 1,0KOHM 1%TK100	
R420	RG 82,5 OHM+-1%TK100 1206 CHIP RESISTOR	RG 0006.8861.00	ROEDERSTEI	DC2 82,5OHM 1%TK100	
R422	RG 301 OHM+-1%TK100 1206 RESISTOR CHIP	RG 0007.5643.00	ROEDERSTEI	DC2 301OHM 1%TK100	
R424	RG 1,21KOHM+-1%TK100 1206 CHIP RESISTOR	RG 0006.9968.00	ROEDERSTEI	DC2 1,21KOHM 1%TK100	
R425	RG 1,5 KOHM+-1%TK100 1206 RESISTOR CHIP	RG 0007.5714.00	ROEDERSTEI	DC2 1,5KOHM 1%TK100	
R426	RG 4,75KOHM+-1%TK100 1206 RESISTOR CHIP	RG 0007.5820.00	ROEDERSTEI	DC2 4,75KOHM 1%TK100	
R427	RG 10,0KOHM+-1%TK100 1206 RG CHIP RESISTOR	RG 0007.0793.00	ROEDERSTEI	DC2 10,0KOHM 1%TK100	
R430	RG 3,32OHM+-1%TK100 1206 CHIP-RESISTOR	RG 0007.8388.00	PHILIPS	RC 02	

MENP5	413 3PUA	Är	Datum Date	Schaltteilliste für Parts list for	Sachnummer Stock No.	Blatt-Nr. Page
	31	16.09.97	EE SYNTHESIZER SYNTHESIZER	1062.6409.01 SA	14+	

095.0026-0693

Für diese Unterlage behalten
Wir uns alle Rechte vor.

Kannz. Comp. No.	Benennung Designation	Sachnummer Stock No.	Hersteller Manufacturer	Bezeichnung Designation	enthalten in contained in
R431	RG 10R +-1% TK200 SMD-RESISTOR EIA0603 NUR VAR/ONLY MOD: 02	0603 RG 0009.5328.00	DRALORIC	CR 0603	
R432	RG 3,320HM+-1%TK100 CHIP-RESISTOR	1206 RG 0007.8388.00	PHILIPS	RC 02	
R434	RG 3,320HM+-1%TK100 CHIP-RESISTOR	1206 RG 0007.8388.00	PHILIPS	RC 02	
R436	RG 3,320HM+-1%TK100 CHIP-RESISTOR	1206 RG 0007.8388.00	PHILIPS	RC 02	
R438	RG 3,320HM+-1%TK100 CHIP-RESISTOR	1206 RG 0007.8388.00	PHILIPS	RC 02	
R440	RG 0,05W 27R +-1% RESISTOR	0805 RG 0007.8936.00	HONEST JAP	MR 08 M 27R 1% 0805	
R442	RG 1,82KOHM+-1%TK100 RESISTOR CHIP	1206 RG 0007.5720.00	ROEDERSTEI	DC2 1,82KOHM 1%TK100	
R444	RG 1,0 KO +-1%TK100 CHIP RESISTOR	1206 RG 0006.7271.00	ROEDERSTEI	DC2 1,0KOHM 1%TK100	
R446	RG 1,21KOHM+-1%TK100 CHIP RESISTOR	1206 RG 0006.9968.00	ROEDERSTEI	DC2 1,21KOHM 1%TK100	
R448	RG 1,0 KO +-1%TK100 CHIP RESISTOR	1206 RG 0006.7271.00	ROEDERSTEI	DC2 1,0KOHM 1%TK100	
R450	RG 82,5 OHM+-1%TK100 CHIP RESISTOR	1206 RG 0006.8861.00	ROEDERSTEI	DC2 82,5OHM 1%TK100	
R452	RG 243 OHM+-1%TK100 RESISTOR CHIP	1206 RG 0007.5620.00	ROEDERSTEI	DC2 243OHM 1%TK100	
R454	RG 1,21KOHM+-1%TK100 CHIP RESISTOR	1206 RG 0006.9968.00	ROEDERSTEI	DC2 1,21KOHM 1%TK100	
R455	RG 1,5 KOHM+-1%TK100 RESISTOR CHIP	1206 RG 0007.5714.00	ROEDERSTEI	DC2 1,5KOHM 1%TK100	
R456	RG 4,75KOHM+-1%TK100 RESISTOR CHIP	1206 RG 0007.5820.00	ROEDERSTEI	DC2 4,75KOHM 1%TK100	
R457	RG 10,0KOHM+-1%TK100 RG CHIP RESISTOR	1206 RG 0007.0793.00	ROEDERSTEI	DC2 10,0KOHM 1%TK100	
R483	RG 100 OHM+-1%TK100 CHIP RESISTOR NICHT BESTUECKT NOT FITTED	1206 RG 0006.8884.00	ROEDERSTEI	DC2 100OHM 1%TK100	
R490	RG 2,21KOHM+-1%TK100 RESISTOR CHIP	1206 RG 0007.5743.00	ROEDERSTEI	DC2 2,21KOHM 1%TK100	
R491	RG 68,1 OHM+-1%TK100 CHIP RESISTOR	1206 RG 0006.8849.00	ROEDERSTEI	DC2 68,1OHM 1%TK100	
R495	RG 82,5 OHM+-1%TK100 CHIP RESISTOR	1206 RG 0006.8861.00	ROEDERSTEI	DC2 82,5OHM 1%TK100	
R496	RG 121 OHM+-1%TK100 CHIP RESISTOR	1206 RG 0006.8903.00	ROEDERSTEI	DC2 121OHM 1%TK100	
R497	RG 68,1 OHM+-1%TK100 CHIP RESISTOR	1206 RG 0006.8849.00	ROEDERSTEI	DC2 68,1OHM 1%TK100	
R499	RG 68,1 OHM+-1%TK100 CHIP RESISTOR	1206 RG 0006.8849.00	ROEDERSTEI	DC2 68,1OHM 1%TK100	
R500	RG 150 OHM+-1%TK100 RESISTOR CHIP	1206 RG 0007.5589.00	ROEDERSTEI	DC2 150OHM 1%TK100	
R502	RG 150 OHM+-1%TK100 RESISTOR CHIP	1206 RG 0007.5589.00	ROEDERSTEI	DC2 150OHM 1%TK100	
R505	RG 182 OHM+-1%TK100 RESISTOR CHIP	1206 RG 0007.5595.00	ROEDERSTEI	DC2 182OHM 1%TK100	
R506	RG 392 OHM+-1%TK100 RESISTOR CHIP	1206 RG 0007.5672.00	ROEDERSTEI	DC2 392OHM 1%TK100	
R507	RG 392 OHM+-1%TK100 RESISTOR CHIP	1206 RG 0007.5672.00	ROEDERSTEI	DC2 392OHM 1%TK100	
R510	RG 1,0 KO +-1%TK100 CHIP RESISTOR	1206 RG 0006.7271.00	ROEDERSTEI	DC2 1,0KOHM 1%TK100	
R511	RG 56,2 OHM+-1%TK100 CHIP RESISTOR	1206 RG 0006.8826.00	ROEDERSTEI	DC2 56,2OHM 1%TK100	
R515	RG 121 OHM+-1%TK100 CHIP RESISTOR	1206 RG 0006.8903.00	ROEDERSTEI	DC2 121OHM 1%TK100	
R520	RG 1,0 KO +-1%TK100 CHIP RESISTOR	1206 RG 0006.7271.00	ROEDERSTEI	DC2 1,0KOHM 1%TK100	
R521	RG 56,2 OHM+-1%TK100 CHIP RESISTOR	1206 RG 0006.8826.00	ROEDERSTEI	DC2 56,2OHM 1%TK100	
R525	RG 332 OHM+-1%TK100 RESISTOR CHIP	1206 RG 0007.5650.00	ROEDERSTEI	DC2 332OHM 1%TK100	
R526	RG 15,0 OHM+-1%TK100 RESISTOR CHIP	1206 RG 0007.5450.00	ROEDERSTEI	DC2 15,0OHM 1%TK100	
R527	RG 332 OHM+-1%TK100 RESISTOR CHIP	1206 RG 0007.5650.00	ROEDERSTEI	DC2 332OHM 1%TK100	
R528	RG 68,1 OHM+-1%TK100 CHIP RESISTOR	1206 RG 0006.8849.00	ROEDERSTEI	DC2 68,1OHM 1%TK100	

095.0028-0693

MENP5	413 3PUA	ÄI	Datum Date	Schaltteilliste für Parts list for	Sachnummer Stock No.	Blatt-Nr. Page
	31	16.09.97	EE SYNTHESIZER SYNTHESIZER	1062.6409.01 SA	15+	

Kennz. Comp. No.	Benennung Designation	Sachnummer Stock No.	Hersteller Manufacturer	Bezeichnung Designation	enthalten in contained in
R530	RG 332 OHM+-1%TK100 1206 RESISTOR CHIP	RG 0007.5650.00	ROEDERSTEI	DC2 332OHM 1%TK100	
R531	RG 27,4KOHM+-1%TK100 1206 RESISTOR CHIP	RG 0007.5895.00	ROEDERSTEI	DC2 27,4KOHM 1%TK100	
R550	RG 150 OHM+-1%TK100 1206 RESISTOR CHIP	RG 0007.5589.00	ROEDERSTEI	DC2 150OHM 1%TK100	
R552	RG 47,5 OHM+-1%TK100 1206 RESISTOR CHIP	RG 0007.5566.00	ROEDERSTEI	DC2 47,5OHM 1%TK100	
R555	RG 100 OHM+-1%TK100 1206 CHIP RESISTOR	RG 0006.8884.00	ROEDERSTEI	DC2 100OHM 1%TK100	
R556	RG 100,0KOH+-1%TK100 1206 CHIP RESISTOR	RG 0007.1948.00	ROEDERSTEI	DC2 100KOHM 1%TK100	
R557	RG 10,0KOHM+-1%TK100 1206 RG CHIP RESISTOR	RG 0007.0793.00	ROEDERSTEI	DC2 10,0KOHM 1%TK100	
R570	RG 392 OHM+-1%TK100 1206 RESISTOR CHIP	RG 0007.5672.00	ROEDERSTEI	DC2 392OHM 1%TK100	
R571	RG 392 OHM+-1%TK100 1206 RESISTOR CHIP	RG 0007.5672.00	ROEDERSTEI	DC2 392OHM 1%TK100	
R579	RG 22,1 OHM+-1%TK100 1206 RESISTOR CHIP	RG 0007.5489.00	ROEDERSTEI	DC2 22,1OHM 1%TK100	
R581	RG 4,75KOHM+-1%TK100 1206 RESISTOR CHIP	RG 0007.5820.00	ROEDERSTEI	DC2 4,75KOHM 1%TK100	
R600	RG 10R +-1% TK50 0805 RESISTOR	RG 0007.8888.00	HONEST_JAP	RN 73 C(E)2X..F (1%)	
R603	RG 68,1 OHM+-1%TK100 1206 CHIP RESISTOR	RG 0006.8849.00	ROEDERSTEI	DC2 68,1OHM 1%TK100	
R605	RG 100 OHM+-1%TK100 1206 CHIP RESISTOR	RG 0006.8884.00	ROEDERSTEI	DC2 100OHM 1%TK100	
R606	RG 100 OHM+-1%TK100 1206 CHIP RESISTOR	RG 0006.8884.00	ROEDERSTEI	DC2 100OHM 1%TK100	
R607	RG 82,5 OHM+-1%TK100 1206 CHIP RESISTOR	RG 0006.8861.00	ROEDERSTEI	DC2 82,5OHM 1%TK100	
R610	RG 68,1 OHM+-1%TK100 1206 CHIP RESISTOR	RG 0006.8849.00	ROEDERSTEI	DC2 68,1OHM 1%TK100	
R611	RG 4,75KOHM+-1%TK100 1206 RESISTOR CHIP	RG 0007.5820.00	ROEDERSTEI	DC2 4,75KOHM 1%TK100	
R615	RG 82,5 OHM+-1%TK100 1206 CHIP RESISTOR	RG 0006.8861.00	ROEDERSTEI	DC2 82,5OHM 1%TK100	
R616	RG 82,5 OHM+-1%TK100 1206 CHIP RESISTOR	RG 0006.8861.00	ROEDERSTEI	DC2 82,5OHM 1%TK100	
R617	RG 82,5 OHM+-1%TK100 1206 CHIP RESISTOR	RG 0006.8861.00	ROEDERSTEI	DC2 82,5OHM 1%TK100	
R620	RG 1,0 KO +-1%TK100 1206 CHIP RESISTOR	RG 0006.7271.00	ROEDERSTEI	DC2 1,0KOHM 1%TK100	
R621	RG 1,0 KO +-1%TK100 1206 CHIP RESISTOR	RG 0006.7271.00	ROEDERSTEI	DC2 1,0KOHM 1%TK100	
R630	RG 1,0 KO +-1%TK100 1206 CHIP RESISTOR	RG 0006.7271.00	ROEDERSTEI	DC2 1,0KOHM 1%TK100	
R631	RG 1,0 KO +-1%TK100 1206 CHIP RESISTOR	RG 0006.7271.00	ROEDERSTEI	DC2 1,0KOHM 1%TK100	
R633	RG 100 OHM+-1%TK100 1206 CHIP RESISTOR	RG 0006.8884.00	ROEDERSTEI	DC2 100OHM 1%TK100	
R635	RG 33,2 OHM+-1%TK100 1206 RESISTOR CHIP	RG 0007.5520.00	ROEDERSTEI	DC2 33,2OHM 1%TK100	
R636	RG 221 OHM+-1%TK100 1206 RESISTOR CHIP	RG 0007.5614.00	ROEDERSTEI	DC2 221OHM 1%TK100	
R637	RG 221 OHM+-1%TK100 1206 RESISTOR CHIP	RG 0007.5614.00	ROEDERSTEI	DC2 221OHM 1%TK100	
R638	RG 4,75KOHM+-1%TK100 1206 RESISTOR CHIP	RG 0007.5820.00	ROEDERSTEI	DC2 4,75KOHM 1%TK100	
R639	RG 4,75KOHM+-1%TK100 1206 RESISTOR CHIP	RG 0007.5820.00	ROEDERSTEI	DC2 4,75KOHM 1%TK100	
R640	RG 10,0 OHM+-1%TK100 1206 CHIP -RESISTOR	RG 0006.8649.00	DRALORIC	CR(B) 1206...	
R643	RG 1,5 KOHM+-1%TK100 1206 RESISTOR CHIP	RG 0007.5714.00	ROEDERSTEI	DC2 1,5KOHM 1%TK100	
R644	RG 562 OHM+-1%TK100 1206 CHIP RESISTOR	RG 0006.9068.00	ROEDERSTEI	DC2 562OHM 1%TK100	
R645	RG 33,2 OHM+-1%TK100 1206 RESISTOR CHIP	RG 0007.5520.00	ROEDERSTEI	DC2 33,2OHM 1%TK100	
R647	RG 4,75KOHM+-1%TK100 1206 RESISTOR CHIP	RG 0007.5820.00	ROEDERSTEI	DC2 4,75KOHM 1%TK100	
R650	RG 4,75KOHM+-1%TK100 1206 RESISTOR CHIP NICHT BESTUECKT NOT FITTED	RG 0007.5820.00	ROEDERSTEI	DC2 4,75KOHM 1%TK100	
R651	RG 4,75KOHM+-1%TK100 1206 RESISTOR CHIP	RG 0007.5820.00	ROEDERSTEI	DC2 4,75KOHM 1%TK100	

Für diese Unterlegungsblätter
Wir uns alle Rechte vor.

095.0026-0893

MENP5	413 3PUA	Ät	Datum Date	Schaltteilliste für Parts list for	Sachnummer Stock No.	Blatt-Nr. Page
		31	16.09.97	EE SYNTHESIZER SYNTHESIZER	1062.6409.01 SA	16+

Für diese Unterlage behalten
wir uns alle Rechte vor.

Kennz. Comp. No.	Benennung Designation		Sachnummer Stock No.	Hersteller Manufacturer	Bezeichnung Designation	enthalten in contained in	
R652	NICHT BESTUECKT NOT FITTED RG 4,75KOHM+-1%TK100 1206 RESISTOR CHIP		RG 0007.5820.00	ROEDERSTEI	DC2 4,75KOHM 1%TK100		
R653	NICHT BESTUECKT NOT FITTED RG 4,75KOHM+-1%TK100 1206 RESISTOR CHIP		RG 0007.5820.00	ROEDERSTEI	DC2 4,75KOHM 1%TK100		
R654	NICHT BESTUECKT NOT FITTED RG 4,75KOHM+-1%TK100 1206 RESISTOR CHIP		RG 0007.5820.00	ROEDERSTEI	DC2 4,75KOHM 1%TK100		
R655	RG 33,2 OHM+-1%TK100 1206 RESISTOR CHIP		RG 0007.5520.00	ROEDERSTEI	DC2 33,2OHM 1%TK100		
R656	RG 4,75KOHM+-1%TK100 1206 RESISTOR CHIP		RG 0007.5820.00	ROEDERSTEI	DC2 4,75KOHM 1%TK100		
R658	RG 221 OHM+-1%TK100 1206 RESISTOR CHIP		RG 0007.5614.00	ROEDERSTEI	DC2 221OHM 1%TK100		
R659	RG 4,75KOHM+-1%TK100 1206 RESISTOR CHIP		RG 0007.5820.00	ROEDERSTEI	DC2 4,75KOHM 1%TK100		
R660	RG 4,75KOHM+-1%TK100 1206 RESISTOR CHIP		RG 0007.5820.00	ROEDERSTEI	DC2 4,75KOHM 1%TK100		
R661	RG 4,75KOHM+-1%TK100 1206 RESISTOR CHIP		RG 0007.5820.00	ROEDERSTEI	DC2 4,75KOHM 1%TK100		
R662	NICHT BESTUECKT NOT FITTED RG 475 OHM+-1%TK100 1206 RESISTOR CHIP		RG 0007.5695.00	ROEDERSTEI	DC2 475OHM 1%TK100		
R663 ..666	RG 4,75KOHM+-1%TK100 1206 RESISTOR CHIP		RG 0007.5820.00	ROEDERSTEI	DC2 4,75KOHM 1%TK100		
R667	RG 4,75KOHM+-1%TK100 1206 RESISTOR CHIP		RG 0007.5820.00	ROEDERSTEI	DC2 4,75KOHM 1%TK100		
R668	NICHT BESTUECKT NOT FITTED RG 4,75KOHM+-1%TK100 1206 RESISTOR CHIP		RG 0007.5820.00	ROEDERSTEI	DC2 4,75KOHM 1%TK100		
R669	NICHT BESTUECKT NOT FITTED RG 4,75KOHM+-1%TK100 1206 RESISTOR CHIP		RG 0007.5820.00	ROEDERSTEI	DC2 4,75KOHM 1%TK100		
R670	NICHT BESTUECKT NOT FITTED RG 4,75KOHM+-1%TK100 1206 RESISTOR CHIP		RG 0007.5820.00	ROEDERSTEI	DC2 4,75KOHM 1%TK100		
R671	NICHT BESTUECKT NOT FITTED RG 4,75KOHM+-1%TK100 1206 RESISTOR CHIP		RG 0007.5820.00	ROEDERSTEI	DC2 4,75KOHM 1%TK100		
R672	NICHT BESTUECKT NOT FITTED RG 4,75KOHM+-1%TK100 1206 RESISTOR CHIP		RG 0007.5820.00	ROEDERSTEI	DC2 4,75KOHM 1%TK100		
R673	NICHT BESTUECKT NOT FITTED RG 4,75KOHM+-1%TK100 1206 RESISTOR CHIP		RG 0007.5820.00	ROEDERSTEI	DC2 4,75KOHM 1%TK100		
R674	NICHT BESTUECKT NOT FITTED RG 4,75KOHM+-1%TK100 1206 RESISTOR CHIP		RG 0007.5820.00	ROEDERSTEI	DC2 4,75KOHM 1%TK100		
R675	NICHT BESTUECKT NOT FITTED RG 4,75KOHM+-1%TK100 1206 RESISTOR CHIP		RG 0007.5820.00	ROEDERSTEI	DC2 4,75KOHM 1%TK100		
R676	NICHT BESTUECKT NOT FITTED RG 4,75KOHM+-1%TK100 1206 RESISTOR CHIP		RG 0007.5820.00	ROEDERSTEI	DC2 4,75KOHM 1%TK100		
R677	NICHT BESTUECKT NOT FITTED RG 4,75KOHM+-1%TK100 1206 RESISTOR CHIP		RG 0007.5820.00	ROEDERSTEI	DC2 4,75KOHM 1%TK100		
R678	NICHT BESTUECKT NOT FITTED RG 4,75KOHM+-1%TK100 1206 RESISTOR CHIP		RG 0007.5820.00	ROEDERSTEI	DC2 4,75KOHM 1%TK100		
MENP5		413 3PUA	A1	Datum Date	Schaltteilliste für Parts list for	Sachnummer Stock No.	Blatt-Nr. Page
 ROHDE & SCHWARZ		31	16.09.97	EE SYNTHESIZER SYNTHESIZER	1062.6409.01 SA	17+	

095.0026-0693

Kennz. Comp. No.	Benennung Designation	Sachnummer Stock No.	Hersteller Manufacturer	Bezeichnung Designation	enthalten in contained in
R679	NOT FITTED RG 4,75KOHM+-1%TK100 1206 RESISTOR CHIP NICHT BESTUECKT NOT FITTED	RG 0007.5820.00	ROEDERSTEI	DC2 4,75KOHM 1%TK100	
R680	RG 4,75KOHM+-1%TK100 1206 RESISTOR CHIP NICHT BESTUECKT NOT FITTED	RG 0007.5820.00	ROEDERSTEI	DC2 4,75KOHM 1%TK100	
R681	RG 4,75KOHM+-1%TK100 1206 RESISTOR CHIP NICHT BESTUECKT NOT FITTED	RG 0007.5820.00	ROEDERSTEI	DC2 4,75KOHM 1%TK100	
R686 ..688	RG 4,75KOHM+-1%TK100 1206 RESISTOR CHIP	RG 0007.5820.00	ROEDERSTEI	DC2 4,75KOHM 1%TK100	
R690 ..693	RG 1,0 OHM+-1%TK100 1206 CHIP-RESISTOR	RG 0007.8265.00	PHILIPS_CO	RC O2	
R695	RG 130 OHM+-1%TK100 1206 RESISTOR CHIP	RG 0007.5572.00	RESISTA	DC2 130OHM 1%TK100	
R696	RG 10,0 OHM+-1%TK100 1206 CHIP -RESISTOR	RG 0006.8649.00	DRALORIC	CR(B) 1206...	
R697	RG 0-OHM WIDERSTAND-CHIP RESISTOR CHIP 0-OHM	RG 0007.5108.00	DRALORIC	CR 1206	
R698	RG 2,21KOHM+-1%TK100 1206 RESISTOR CHIP	RG 0007.5743.00	ROEDERSTEI	DC2 2,21KOHM 1%TK100	
R700	RG 4,75KOHM+-1%TK100 1206 RESISTOR CHIP	RG 0007.5820.00	ROEDERSTEI	DC2 4,75KOHM 1%TK100	
R701	RG 4,75KOHM+-1%TK100 1206 RESISTOR CHIP	RG 0007.5820.00	ROEDERSTEI	DC2 4,75KOHM 1%TK100	
R702	RG 221 OHM+-1%TK100 1206 RESISTOR CHIP	RG 0007.5614.00	ROEDERSTEI	DC2 221OHM 1%TK100	
R703	RG 1,0 KO +-1%TK100 1206 CHIP RESISTOR	RG 0006.7271.00	ROEDERSTEI	DC2 1,0KOHM 1%TK100	
R704	RG 1,0 KO +-1%TK100 1206 CHIP RESISTOR	RG 0006.7271.00	ROEDERSTEI	DC2 1,0KOHM 1%TK100	
R705	RG 274 OHM+-1%TK100 1206 RESISTOR CHIP	RG 0007.5637.00	ROEDERSTEI	DC2 274OHM 1%TK100	
R706	RG 2,0 KOHM+-1%TK100 1206 RESISTOR CHIP	RG 0007.5737.00	ROEDERSTEI	DC2 2,0KOHM 1%TK100	
R707	RG 1,0 KO +-1%TK100 1206 CHIP RESISTOR	RG 0006.7271.00	ROEDERSTEI	DC2 1,0KOHM 1%TK100	
R708	RG 1,0 KO +-1%TK100 1206 CHIP RESISTOR	RG 0006.7271.00	ROEDERSTEI	DC2 1,0KOHM 1%TK100	
R709	RG 10,0 OHM+-1%TK100 1206 CHIP -RESISTOR	RG 0006.8649.00	DRALORIC	CR(B) 1206...	
R710	RG 2,0 KOHM+-1%TK100 1206 RESISTOR CHIP	RG 0007.5737.00	ROEDERSTEI	DC2 2,0KOHM 1%TK100	
R712	RG 10,0KOHM+-1%TK100 1206 RG CHIP RESISTOR	RG 0007.0793.00	ROEDERSTEI	DC2 10,0KOHM 1%TK100	
R713	RG 8,25KOHM+-1%TK100 1206 CHIP RESISTOR	RG 0007.0770.00	ROEDERSTEI	DC2 8,25KOHM 1%TK100	
R719	RG 47,5 OHM+-1%TK100 1206 RESISTOR CHIP	RG 0007.5566.00	ROEDERSTEI	DC2 47,5OHM 1%TK100	
R720	RG 4,75KOHM+-1%TK100 1206 RESISTOR CHIP	RG 0007.5820.00	ROEDERSTEI	DC2 4,75KOHM 1%TK100	
R721	RG 121,0KOH+-1%TK100 1206 CHIP RESISTOR	RG 0007.1960.00	RESISTA	DC2 121KOHM 1% TK100	
R722	RG 27,4KOHM+-1%TK100 1206 RESISTOR CHIP	RG 0007.5895.00	ROEDERSTEI	DC2 27,4KOHM 1%TK100	
R723	RG 15,0KOHM+-1%TK100 1206 RESISTOR CHIP	RG 0007.5843.00	ROEDERSTEI	DC2 15,0KOHM 1%TK100	
R724	RG 9,09KOHM+-1%TK100 1206 CHIP RESISTOR	RG 0007.0787.00	ROEDERSTEI	DC2 9,09KOHM 1%TK100	
R725	RG 6,19KOHM+-1%TK100 1206 RG CHIP RESISTOR	RG 0007.0741.00	ROEDERSTEI	DC2 6,19KOHM 1%TK100	
R726	RG 4,75KOHM+-1%TK100 1206 RESISTOR CHIP	RG 0007.5820.00	ROEDERSTEI	DC2 4,75KOHM 1%TK100	
R727	RG 3,57KOHM+-1%TK100 1206 RESISTOR CHIP	RG 0007.5795.00	ROEDERSTEI	DC2 3,57KOHM 1%TK100	
R728	RG 2,74KOHM+-1%TK100 1206 RESISTOR CHIP	RG 0007.5766.00	ROEDERSTEI	DC2 2,74KOHM 1%TK100	
R729	RG 6,81KOHM+-1%TK100 1206 CHIP RESISTOR	RG 0007.0758.00	ROEDERSTEI	DC2 6,81KOHM 1%TK100	
R730	RG 2,74KOHM+-1%TK100 1206 RESISTOR CHIP	RG 0007.5766.00	ROEDERSTEI	DC2 2,74KOHM 1%TK100	
R733	RG 100,0KOH+-1%TK100 1206 CHIP RESISTOR	RG 0007.1948.00	ROEDERSTEI	DC2 100KOHM 1%TK100	

Für diese Unterlage behalten wir uns alle Rechte vor.

MENP5	413 3PUA	ÄI	Datum Date	Schaltteilliste für Parts list for	Sachnummer Stock No.	Blatt-Nr. Page
		31	16.09.97	EE SYNTHESIZER SYNTHESIZER	1062.6409.01 SA	18+

095.0028-0693

Für diese Unterlage behalten wir uns alle Rechte vor.

Kennz. Comp. No.	Benennung Designation	Sachnummer Stock No.	Hersteller Manufacturer	Bezeichnung Designation	enthalten in contained in
R750	RG 33,2 OHM+-1%TK100 1206 RESISTOR CHIP	RG 0007.5520.00	ROEDERSTEI	DC2 33,2OHM 1%TK100	
R751	RG 22,1 OHM+-1%TK100 1206 RESISTOR CHIP	RG 0007.5489.00	ROEDERSTEI	DC2 22,1OHM 1%TK100	
R752	RG 30,1 KOHM+-1%TK100 1206 RESISTOR CHIP	RG 0007.5908.00	ROEDERSTEI	DC2 30,1KOHM 1%TK100	
R753	RG 7,5 KOHM+-1%TK100 1206 RG CHIP RESISTOR	RG 0007.0764.00	ROEDERSTEI	DC2 7,5KOHM 1%TK100	
R762	RG 5,11 KOHM+-1%TK100 1206 CHIP RESISTOR	RG 0007.0729.00	ROEDERSTEI	DC2 5,11KOHM 1%TK100	
R763	RG 4,32 KOHM+-1%TK100 1206 RESISTOR CHIP	RG 0007.5814.00	RESISTA	DC2 4,32KOHM 1%TK100	
R764	RG 332 OHM+-1%TK100 1206 RESISTOR CHIP	RG 0007.5650.00	ROEDERSTEI	DC2 332OHM 1%TK100	
R777	RG 15,0 OHM+-1%TK100 1206 RESISTOR CHIP	RG 0007.5450.00	ROEDERSTEI	DC2 15,0OHM 1%TK100	
R780	RG 15,0 KOHM+-1%TK100 1206 RESISTOR CHIP	RG 0007.5843.00	ROEDERSTEI	DC2 15,0KOHM 1%TK100	
R781	RG 13,0 KOHM+-1%TK100 1206 RESISTOR CHIP	RG 0007.5837.00	ROEDERSTEI	DC2 13,0KOHM 1%TK100	
R782	RG 1,0 MOHM+-1%TK100 1206 CHIP RESISTOR	RG 0815.7532.00	DRALORIC	CRC 1206	
R783	RG 20,0 KOHM+-1%TK100 1206 RESISTOR CHIP	RG 0007.5866.00	ROEDERSTEI	DC2 20,0KOHM 1%TK100	
R784	RG 10,0 KOHM+-1%TK100 1206 RG CHIP RESISTOR	RG 0007.0793.00	ROEDERSTEI	DC2 10,0KOHM 1%TK100	
R785	RG 221 OHM+-1%TK100 1206 RESISTOR CHIP	RG 0007.5614.00	ROEDERSTEI	DC2 221OHM 1%TK100	
R786	RG 22,1 KOHM+-1%TK100 1206 RESISTOR CHIP	RG 0007.5872.00	ROEDERSTEI	DC2 22,1KOHM 1%TK100	
R787	RG 15,0 KOHM+-1%TK100 1206 RESISTOR CHIP	RG 0007.5843.00	ROEDERSTEI	DC2 15,0KOHM 1%TK100	
R792	RG 10,0 OHM+-1%TK100 1206 CHIP -RESISTOR	RG 0006.8649.00	DRALORIC	CR(B) 1206...	
R793	RG 10,0 OHM+-1%TK100 1206 CHIP -RESISTOR	RG 0006.8649.00	DRALORIC	CR(B) 1206...	
R800	RG 100 OHM+-1%TK100 1206 CHIP RESISTOR	RG 0006.8884.00	ROEDERSTEI	DC2 100OHM 1%TK100	
R802	RG 1,0 KO +-0,1%TK25 1206 SMD-RESISTOR	0009.7595.00	PHILIPS_CO	MPC 01	
R803	RG 110,0 KOHM+-1%TK100 1206 CHIP RESISTOR	RG 0007.1954.00	ROEDERSTEI	DC2 110KOHM 1%TK100	
R804	RG 619 OHM+-1%TK100 1206 CHIP RESISTOR	RG 0006.9074.00	ROEDERSTEI	DC2 619OHM 1%TK100	
R812	RG 988 OHM+-0,1%TK25 1206 RESISTOR	0010.1951.00	MIKRO-TEK-	CMF 1206	
R813	RG 1,0 MOHM+-1%TK100 1206 CHIP RESISTOR	RG 0815.7532.00	DRALORIC	CRC 1206	
R820	RG 15,0 OHM+-1%TK100 1206 RESISTOR CHIP	RG 0007.5450.00	ROEDERSTEI	DC2 15,0OHM 1%TK100	
R834	RG 4,75 OHM+-1%TK100 1206 CHIP-RESISTOR	RG 0007.8420.00	PHILIPS	RC 02	
R840	RG 4,75 KOHM+-1%TK100 1206 RESISTOR CHIP	RG 0007.5820.00	ROEDERSTEI	DC2 4,75KOHM 1%TK100	
R843	RG 3,32 KOH+-0,1%TK25 1206 SMD-RESISTOR EIA1206 NUR VAR/ONLY MOD: 02 43	0009.7772.00	MIKRO-TEK-	CMF 1206	
R843	RL 0,35W2,34 KOHM+-0,1%T25 RESISTOR NUR VAR/ONLY MOD: 04	RL 0083.9852.00	DRALORIC	SMA0207/2,34K-B-E	
R844	RG 681 OHM+-1%TK100 1206 CHIP RESISTOR	RG 0006.9080.00	ROEDERSTEI	DC2 681OHM 1%TK100	
R845	RG 825 OHM+-1%TK100 1206 CHIP RESISTOR	RG 0006.7259.00	ROEDERSTEI	DC2 825OHM 1%TK100	
R846	RG 2,21 KOHM+-1%TK100 1206 RESISTOR CHIP	RG 0007.5743.00	ROEDERSTEI	DC2 2,21KOHM 1%TK100	
R847	RG 10,0 OHM+-1%TK100 1206 CHIP -RESISTOR	RG 0006.8649.00	DRALORIC	CR(B) 1206...	
R848	RG 1,0 KO +-0,1%TK25 1206 SMD-RESISTOR	0009.7595.00	PHILIPS_CO	MPC 01	
R849	RG 1,82 KOH+-0,1%TK25 1206 SMD-RESISTOR	0009.8010.00	MIKRO-TEK-	CMF 1206	
R850	RG 75,0 OHM+-1%TK100 1206 CHIP RESISTOR	RG 0006.8855.00	ROEDERSTEI	DC2 75,0OHM	
R851	RG 3,32 KOHM+-1%TK100 1206 RESISTOR CHIP	RG 0007.5789.00	ROEDERSTEI	DC2 3,32KOHM 1%TK100	
R853	RG 27,4 KOHM+-1%TK100 1206 RESISTOR CHIP	RG 0007.5895.00	ROEDERSTEI	DC2 27,4KOHM 1%TK100	

MENP5

413 3PUA

Äi

Datum
Date

31

16.09.97

Schaltteilliste für
Parts list for

Sachnummer
Stock No.

Blatt-Nr.
Page



ROHDE & SCHWARZ

EE SYNTHESIZER
SYNTHESIZER

1062.6409.01 SA

19+

095.0026-0693

Kennz. Comp. No.	Benennung Designation	Sachnummer Stock No.	Hersteller Manufacturer	Bezeichnung Designation	enthalten in contained in
R857	RG 4,75KOHM+-1%TK100 1206 RESISTOR CHIP	RG 0007.5820.00	ROEDERSTEI	DC2 4,75KOHM 1%TK100	
R860	RG 200 OHM+-1%TK100 1206 RESISTOR CHIP	RG 0007.5608.00	ROEDERSTEI	DC2 200OHM 1%TK100	
R861	RG 29,1KOH+-0,1%TK25 1206 RESISTOR	0010.4109.00	MIKRO-TEK-	CMF 1206	
R861	NUR VAR/ONLY MOD: 02 43 RL 0,35W28,0KOHM+-0,1%T25 RESISTOR	RL 0084.3929.00	RESISTA	MK2	
R862	NUR VAR/ONLY MOD: 04 RG 118 OHM+-0,1%TK25 1206 RESISTOR	0010.3977.00	MIKRO-TEK-	CMF 1206	
R862	NUR VAR/ONLY MOD: 02 43 RL 0,35W169 OHM+-0,1%TK25 RESISTOR	RL 0083.7666.00	RESISTA	MK2	
R863	NUR VAR/ONLY MOD: 04 RG 2,94KOH+-0,1%TK25 1206 RESISTOR	0010.4038.00	MIKRO-TEK-	CMF 1206	
R863	NUR VAR/ONLY MOD: 02 43 RL 0,35W4,17KOHM+-0,1%T25 RESISTOR	RL 0084.2339.00	RESISTA	MK2	
R864	NUR VAR/ONLY MOD: 04 RG 2,74KOHM+-1%TK100 1206 RESISTOR CHIP	RG 0007.5766.00	ROEDERSTEI	DC2 2,74KOHM 1%TK100	
R865	RG 10,0 OHM+-1%TK100 1206 CHIP -RESISTOR	RG 0006.8649.00	DRALORIC	CR(B) 1206...	
R866	RG 10,0 OHM+-1%TK100 1206 CHIP -RESISTOR	RG 0006.8649.00	DRALORIC	CR(B) 1206...	
R870	RG 4,75KOHM+-1%TK100 1206 RESISTOR CHIP	RG 0007.5820.00	ROEDERSTEI	DC2 4,75KOHM 1%TK100	
R871	RG 274 KOHM+-1%TK100 1206 RESISTOR CHIP	RG 0007.4460.00	ROEDERSTEI	DC2 274KOHM 1%TK100	
R872	RG 4,75KOHM+-1%TK100 1206 RESISTOR CHIP	RG 0007.5820.00	ROEDERSTEI	DC2 4,75KOHM 1%TK100	
R873	RG 274 KOHM+-1%TK100 1206 RESISTOR CHIP	RG 0007.4460.00	ROEDERSTEI	DC2 274KOHM 1%TK100	
R874	RG 475 OHM+-1%TK100 1206 RESISTOR CHIP	RG 0007.5695.00	ROEDERSTEI	DC2 475OHM 1%TK100	
R875	RG 475 OHM+-1%TK100 1206 RESISTOR CHIP	RG 0007.5695.00	ROEDERSTEI	DC2 475OHM 1%TK100	
R880	RG 47,5 OHM+-1%TK100 1206 RESISTOR CHIP	RG 0007.5566.00	ROEDERSTEI	DC2 47,5OHM 1%TK100	
R881	RG 475 OHM+-1%TK100 1206 RESISTOR CHIP	RG 0007.5695.00	ROEDERSTEI	DC2 475OHM 1%TK100	
R882	RG 47,5 OHM+-1%TK100 1206 RESISTOR CHIP	RG 0007.5566.00	ROEDERSTEI	DC2 47,5OHM 1%TK100	
R883	RG 475 OHM+-1%TK100 1206 RESISTOR CHIP	RG 0007.5695.00	ROEDERSTEI	DC2 475OHM 1%TK100	
R884	RG 10,0 OHM+-1%TK100 1206 CHIP -RESISTOR	RG 0006.8649.00	DRALORIC	CR(B) 1206...	
R885	RG 47,5 OHM+-1%TK100 1206 RESISTOR CHIP	RG 0007.5566.00	ROEDERSTEI	DC2 47,5OHM 1%TK100	
R930	RS 0,25W 1KOHM +-20% SMD RG POTENTIOMETER	RS 0007.9610.00	BOURNS	3314G-1-102	
R931	RG 9,09KOHM+-1%TK100 1206 CHIP RESISTOR	RG 0007.0787.00	ROEDERSTEI	DC2 9,09KOHM 1%TK100	
R932	RG 7,5KOHM+-1%TK100 1206 RG CHIP RESISTOR	RG 0007.0764.00	ROEDERSTEI	DC2 7,50KOHM 1%TK100	
R933	RG 7,5KOHM+-1%TK100 1206 RG CHIP RESISTOR	RG 0007.0764.00	ROEDERSTEI	DC2 7,50KOHM 1%TK100	
R938	RG 51,1KOHM+-1%TK100 1206 CHIP RESISTOR	RG 0007.1877.00	ROEDERSTEI	DC2 51,1KOHM 1%TK100	
R939	RK SMD-HEISSL.22K 1206 SMD-NTC-RESISTOR	0008.9220.00	SIEMENS	B57621-C223-J	
R940	RG 1,21KOHM+-1%TK100 1206 CHIP RESISTOR	RG 0006.9968.00	ROEDERSTEI	DC2 1,21KOHM 1%TK100	
R943	RG 1,0 KO +-1%TK100 1206 CHIP RESISTOR	RG 0006.7271.00	ROEDERSTEI	DC2 1,0KOHM 1%TK100	
R949	RG 4,75KOHM+-1%TK100 1206 RESISTOR CHIP	RG 0007.5820.00	ROEDERSTEI	DC2 4,75KOHM 1%TK100	
R950	RG 2,74KOHM+-1%TK100 1206 RESISTOR CHIP	RG 0007.5766.00	ROEDERSTEI	DC2 2,74KOHM 1%TK100	
R951	RG 1,21KOHM+-1%TK100 1206 CHIP RESISTOR	RG 0006.9968.00	ROEDERSTEI	DC2 1,21KOHM 1%TK100	
R952	RG 5,11KOHM+-1%TK100 1206 CHIP RESISTOR	RG 0007.0729.00	ROEDERSTEI	DC2 5,11KOHM 1%TK100	
R953	RG 5,62KOHM+-1%TK100 1206 CHIP RESISTOR	RG 0007.0735.00	ROEDERSTEI	DC2 5,62KOHM 1%TK100	

MENP5	413 3PUA	Äi	Datum Date	Schaltteilliste für Parts list for	Sachnummer Stock No.	Blatt-Nr. Page
	ROHDE & SCHWARZ	31	16.09.97	EE SYNTHESIZER SYNTHESIZER	1062.6409.01 SA	20+

Wir uns alle Rechte vor.

095.0028-0693

Für diese Unterlage behalten wir uns alle Rechte vor.

Kennz. Comp. No.	Benennung Designation	Sachnummer Stock No.	Hersteller Manufacturer	Bezeichnung Designation	enthalten in contained in
R954	RG 9,09KOHM+-1%TK100 1206 CHIP RESISTOR	RG 0007.0787.00	ROEDERSTEI	DC2 9,09KOHM 1%TK100	
R955	RG 39,2KOHM+-1%TK100 1206 RESISTOR CHIP	RG 0007.5937.00	ROEDERSTEI	DC2 39,2KOHM 1%TK100	
R956	RG 475 OHM+-1%TK100 1206 RESISTOR CHIP	RG 0007.5695.00	ROEDERSTEI	DC2 475OHM 1%TK100	
R957	RG 4,75KOHM+-1%TK100 1206 RESISTOR CHIP	RG 0007.5820.00	ROEDERSTEI	DC2 4,75KOHM 1%TK100	
R958	RG 4,75KOHM+-1%TK100 1206 RESISTOR CHIP	RG 0007.5820.00	ROEDERSTEI	DC2 4,75KOHM 1%TK100	
R960	RG 379 OHM+-0,1%TK25 1206 RESISTOR	0010.4009.00	MIKRO-TEK-	CMF 1206	
R961	RG 154 OHM+-0,1%TK25 1206 RESISTOR	0010.3983.00	MIKRO-TEK-	CMF 1206	
R962	RG 1,82KOHM+-1%TK100 1206 RESISTOR CHIP NICHT BESTUECKT NOT FITTED	RG 0007.5720.00	ROEDERSTEI	DC2 1,82KOHM 1%TK100	
R963	RG 234 OHM+-0,1%TK25 1206 RESISTOR	0010.3990.00	MIKRO-TEK-	CMF 1206	
..968	RG 1040HM+-0,1%TK25 1206	0009.8910.00	PHILIPS_CO	MPC 01	
..973	SMD-RESISTOR EIA1206				
R974	RG 156 OHM+-0,1%TK25 1206 SMD-RESISTOR EIA1206	0009.8779.00	MIKRO-TEK-	CMF 1206	
R975	RG 156 OHM+-0,1%TK25 1206 SMD-RESISTOR EIA1206	0009.8779.00	MIKRO-TEK-	CMF 1206	
R980	RG 47,5 OHM+-1%TK100 1206 RESISTOR CHIP	RG 0007.5566.00	ROEDERSTEI	DC2 47,5OHM 1%TK100	
R986	RG 10,0 OHM+-1%TK100 1206 CHIP -RESISTOR	RG 0006.8649.00	DRALORIC	CR(B) 1206...	
R987	RG 4,75OHM+-1%TK100 1206 CHIP-RESISTOR	RG 0007.8420.00	PHILIPS	RC 02	
R990	RG 4,75KOHM+-1%TK100 1206 RESISTOR CHIP	RG 0007.5820.00	ROEDERSTEI	DC2 4,75KOHM 1%TK100	
R991	RG 15,0KOHM+-1%TK100 1206 RESISTOR CHIP	RG 0007.5843.00	ROEDERSTEI	DC2 15,0KOHM 1%TK100	
R993	RG 22,1 OHM+-1%TK100 1206 RESISTOR CHIP	RG 0007.5489.00	ROEDERSTEI	DC2 22,1OHM 1%TK100	
R994	RG 2,21KOHM+-1%TK100 1206 RESISTOR CHIP	RG 0007.5743.00	ROEDERSTEI	DC2 2,21KOHM 1%TK100	
R995	RG 3,32KOHM+-1%TK100 1206 RESISTOR CHIP	RG 0007.5789.00	ROEDERSTEI	DC2 3,32KOHM 1%TK100	
R996	RG 4,75KOHM+-1%TK100 1206 RESISTOR CHIP	RG 0007.5820.00	ROEDERSTEI	DC2 4,75KOHM 1%TK100	
V20	AK BCP68-16 N 20V TRANS TRANSISTOR BCP68	0008.2019.00	PHILIPS	BCP68-25	
V110	AD BAS32 75V UDI DIODE	AD 0006.7288.00	PHILIPS	BAS32 (L)	
V120	AE BZV55/C5V1 0.5W ZDI ZENER DIODE	AE 0006.9839.00	PHILIPS_SE	BZV55B5V1 (GEG)	
V200	AK BC860B P 45V 200MA TRANSISTOR	AK 0007.7975.00	MOTOROLA	BC860B	
V200	NUR VAR/ONLY MOD: 02 43 AK BCX17 P 45V 500MA TRANSISTOR	AK 0007.2080.00	PHILIPS	BCX17	
V205	NUR VAR/ONLY MOD: 04 AK BFS19 N 20V 30MA TRANSISTOR	0350.9985.00	PHILIPS	BFS19	
V210	AK BSV52 N 12V 100MA TRANSISTOR	AK 0007.3434.00	PHILIPS	BSV52	
V212	AE HSMS2800 SCHOTTKY DIODE	AE 0836.8421.00	HEWLETT_PA	HSMS-2800	
V215	AK BFS19 N 20V 30MA TRANSISTOR	0350.9985.00	PHILIPS	BFS19	
V216	AK BSV52 N 12V 100MA TRANSISTOR	AK 0007.3434.00	PHILIPS	BSV52	
V220	AE HSMS2800 SCHOTTKY DIODE	AE 0836.8421.00	HEWLETT_PA	HSMS-2800	
V235	AE BAT18 BER.SCH.DI.VHF DIODE	0820.3260.00	VALVO	BAT18	
V240	AD BAS32 75V UDI DIODE	AD 0006.7288.00	PHILIPS	BAS32 (L)	
V245	AE BZV55/C5V6 0.5W ZDI ZENER DIODE	AE 0006.9845.00	PHILIPS	BZV55B5V6	
V247	AD BAV70 70V DUD UDI DUAL DIODE COMMON CATHODE	0007.9278.00	PHILIPS	BAV70	

MENP5

413 3PUA

Ät

Datum
Date

Schaltteilleiste für
Parts list for

Sachnummer
Stock No.

Blatt-Nr.
Page

 **ROHDE & SCHWARZ**

31

16.09.97

EE SYNTHESIZER
SYNTHESIZER

1062.6409.01 SA

21+

095.0026-0693

Kennz. Comp. No.	Benennung Designation	Sachnummer Stock No.	Hersteller Manufacturer	Bezeichnung Designation	enthalten in contained in
V255	AD BAV70 70V DUO UDI DUAL DIODE COMMON CATHODE	0007.9278.00	PHILIPS	BAV70	
V260	AE BZV55/10V 0,5W ZDI ZENER DIODE	AE 0006.9880.00	PHILIPS_SE	BZV55C10	
V265	AE HSMS2800 SCHOTTKY DIODE	AE 0836.8421.00	HEWLETT_PA	HSMS-2800	
V300	AE BB535 18,7/2,1P CDI TUNING DIODE	1039.3107.00	SIEMENS	BB535/Q62702-B651	
V305	AK NE85639 N 12V 100MA TRANSISTOR	1027.4161.00	NEC	2SC4093 T1	
V310	AK BC860B P 45V 200MA TRANSISTOR	AK 0007.7975.00	MOTOROLA	BC860B	
V330	AM CF739 10V DG MESF DUAL-GATE GAAS MESFET	4017.0604.00	SIEMENS	CF739 E7845	
V340	AK BC860B P 45V 200MA TRANSISTOR	AK 0007.7975.00	MOTOROLA	BC860B	
V345	AK BC850B N 45V 200MA TRANSISTOR	AK 0007.7969.00	VALVO	BC850B	
V347	AE HSMS2810 SCHOTTKY DIODE	0520.7340.00	HEWLETT_PA	HSMS2810	
V370	AK BSV52 N 12V 100MA TRANSISTOR	AK 0007.3434.00	PHILIPS	BSV52	
V400	AE BB535 18,7/2,1P CDI TUNING DIODE	1039.3107.00	SIEMENS	BB535/Q62702-B651	
V403	AK BFG540X N 15V 120MA TRANSISTOR	1062.6496.00	PHILIPS	BFG540/X	
V404	AK BCX19 N 45V 500MA TRANSISTOR	6014.2567.00	PHILIPS_SE	BCX19	
V406	AK BC850B N 45V 200MA TRANSISTOR	AK 0007.7969.00	VALVO	BC850B	
V408	AK BC860B P 45V 200MA TRANSISTOR	AK 0007.7975.00	MOTOROLA	BC860B	
V410	AK BC860B P 45V 200MA TRANSISTOR	AK 0007.7975.00	MOTOROLA	BC860B	
V428	AE BB535 18,7/2,1P CDI TUNING DIODE	1039.3107.00	SIEMENS	BB535/Q62702-B651	
V429	NUR VAR/ONLY MOD: 43 AE BB535 18,7/2,1P CDI TUNING DIODE	1039.3107.00	SIEMENS	BB535/Q62702-B651	
V430	NUR VAR/ONLY MOD: 43 AE BB535 18,7/2,1P CDI TUNING DIODE	1039.3107.00	SIEMENS	BB535/Q62702-B651	
V431	AE BB535 18,7/2,1P CDI TUNING DIODE	1039.3107.00	SIEMENS	BB535/Q62702-B651	
V432	AE BB535 18,7/2,1P CDI TUNING DIODE	1039.3107.00	SIEMENS	BB535/Q62702-B651	
V433	AE BB535 18,7/2,1P CDI TUNING DIODE	1039.3107.00	SIEMENS	BB535/Q62702-B651	
V434	NUR VAR/ONLY MOD: 02 AK BFG540X N 15V 120MA TRANSISTOR	1062.6496.00	PHILIPS	BFG540/X	
V436	AK BCX19 N 45V 500MA TRANSISTOR	6014.2567.00	PHILIPS_SE	BCX19	
V438	AK BC850B N 45V 200MA TRANSISTOR	AK 0007.7969.00	VALVO	BC850B	
V440	AK BC860B P 45V 200MA TRANSISTOR	AK 0007.7975.00	MOTOROLA	BC860B	
V480	AK BC860B P 45V 200MA TRANSISTOR	AK 0007.7975.00	MOTOROLA	BC860B	
V490	AE BAR64 PIN PIN DIODE	1039.3059.00	SIEMENS	BAR64 (Q62702A1041)	
V492	AE BAR64 PIN PIN DIODE	1039.3059.00	SIEMENS	BAR64 (Q62702A1041)	
V500	AE BAR64 PIN PIN DIODE	1039.3059.00	SIEMENS	BAR64 (Q62702A1041)	
V502	AE BAR64 PIN PIN DIODE	1039.3059.00	SIEMENS	BAR64 (Q62702A1041)	
V510	AK BC860B P 45V 200MA TRANSISTOR	AK 0007.7975.00	MOTOROLA	BC860B	
V520	AK BC860B P 45V 200MA TRANSISTOR	AK 0007.7975.00	MOTOROLA	BC860B	
V532	AE BAR64 PIN PIN DIODE	1039.3059.00	SIEMENS	BAR64 (Q62702A1041)	
V550	AE BAR64 PIN PIN DIODE	1039.3059.00	SIEMENS	BAR64 (Q62702A1041)	
V551	AE BAR64 PIN PIN DIODE	1039.3059.00	SIEMENS	BAR64 (Q62702A1041)	
V553	AE BAR64 PIN PIN DIODE	1039.3059.00	SIEMENS	BAR64 (Q62702A1041)	
V555	AE HSMS2810 SCHOTTKY DIODE	0520.7340.00	HEWLETT_PA	HSMS2810	
V600	AK BFQ81 N 16V 30MA TRANSISTOR	0920.1717.00	SIEMENS	Q62702-F1049	

Für diese Unterlage behalten wir uns alle Rechte vor.

095.0026-0693

MENP5	413 3PUA	ÄI	Datum Date	Schaltteilliste für Parts list for	Sachnummer Stock No.	Blatt-Nr. Page
	31		16.09.97	EE SYNTHESIZER SYNTHESIZER	1062.6409.01 SA	22+

Für diese Unterlage behalten wir uns alle Rechte vor.

Kannz. Comp. No.	Benennung Designation	Sachnummer Stock No.	Hersteller Manufacturer	Bezeichnung Designation	enthalten in contained in
V695	AK BCP68-16 N 20V TRANS TRANSISTOR BCP68	0008.2019.00	PHILIPS	BCP68-25	
V696	AE 1N827 6,2V REFDI REFERENCE DIODE	AE 0418.0029.00	COMPENSATE	1N827(A)	
V700	AD BAV70 70V DUO UDI DUAL DIODE COMMON CATHODE	0007.9278.00	PHILIPS	BAV70	
V719	AE BZV55/C4V7 0.5W ZDI ZENER DIODE	AE 0006.9822.00	PHILIPS	BZV55B4V7	
V750	AK BCX19 N 45V 500MA TRANSISTOR	6014.2567.00	PHILIPS_SE	BCX19	
V755	AK BCX17 P 45V 500MA TRANSISTOR	AK 0007.2080.00	PHILIPS	BCX17	
V757	AD BAS32 75V UDI DIODE	AD 0006.7288.00	PHILIPS	BAS32 (L)	
V765 ..768	AD BAV99 70V DUO UDI DIODE	AD 0911.0092.00	VALVO	BAV99	
V780	AM BSS123 N-E 100V MOSF FET	0815.7961.00	SIEMENS	BSS 123 E-6327	
V781	AD BAS32 75V UDI DIODE	AD 0006.7288.00	PHILIPS	BAS32 (L)	
V787	AE BZV55/C5V1 0.5W ZDI ZENER DIODE	AE 0006.9839.00	PHILIPS_SE	BZV55B5V1 (GEG)	
V800	AD BAV99 70V DUO UDI DIODE	AD 0911.0092.00	VALVO	BAV99	
V902	AD BAS32 75V UDI DIODE	AD 0006.7288.00	PHILIPS	BAS32 (L)	
V946	AD BAV99 70V DUO UDI DIODE	AD 0911.0092.00	VALVO	BAV99	
V947	AD BAV99 70V DUO UDI DIODE	AD 0911.0092.00	VALVO	BAV99	
V951	AD BAV99 70V DUO UDI DIODE	AD 0911.0092.00	VALVO	BAV99	
V952	AD BAV99 70V DUO UDI DIODE	AD 0911.0092.00	VALVO	BAV99	
V955	AK BC860B P 45V 200MA TRANSISTOR	AK 0007.7975.00	MOTOROLA	BC860B	
V960	AM SST108 N-D 25V JFET JFET TRANSISTOR	6007.3949.00	SILICONIX	SST108	
V961	AE BZV55/C5V1 0.5W ZDI ZENER DIODE	AE 0006.9839.00	PHILIPS_SE	BZV55B5V1 (GEG)	
X1	FP STECKERLEISTE 32POL. CONNECTOR 32P.	FP 0008.5718.00	SIEMENS	V42254-B1200-B611	
X20	FP STIFTLISTE 36P.R2,54 PIN CONNECTOR 3-POLIG	FP 0242.3600.00	BINDER	742-11-0179-00-36	
X75	FP STIFTLISTE 36P.R2,54 PIN CONNECTOR 3-POLIG	FP 0242.3600.00	BINDER	742-11-0179-00-36	
X80	FP STIFTLISTE 36P.R2,54 PIN CONNECTOR 3-POLIG	FP 0242.3600.00	BINDER	742-11-0179-00-36	
X84	FP STIFTLISTE 36P.R2,54 PIN CONNECTOR 3-POLIG	FP 0242.3600.00	BINDER	742-11-0179-00-36	
X124	FJ EINBAUWINKELST. SMC ANGLE CONNECTOR	FJ 0249.9684.00	ROSENBERGE	39S-205-400-D3	
X125	FJ EINBAUWINKELST. SMC ANGLE CONNECTOR	FJ 0249.9684.00	ROSENBERGE	39S-205-400-D3	
X127	FJ EINBAUSTECKER F.GS SMB ANGLE CONNECTOR	FJ 0602.8804.00	IMS	81.1524.201	
X128	FJ EINBAUSTECKER F.GS SMB ANGLE CONNECTOR	FJ 0602.8804.00	IMS	81.1524.201	
X300	ER KERAMIK RESONATOR 700M RESONATOR	1062.6421.00	SIEMENS	B69610-G7006-A612	
Z1 ..14	LD SMD-T-FILTER 3,3NF SMD-FILTER	1039.1362.00	MURATA	NFM61R20T332T1	
Z102	LD SMD-T-FILTER 100PF SMD-FILTER	1039.1356.00	MURATA	NFM61ROOT101T1	
Z104	LD SMD-T-FILTER 100PF SMD-FILTER	1039.1356.00	MURATA	NFM61ROOT101T1	
Z106	LD SMD-T-FILTER 100PF SMD-FILTER	1039.1356.00	MURATA	NFM61ROOT101T1	
Z108	LD SMD-T-FILTER 100PF SMD-FILTER	1039.1356.00	MURATA	NFM61ROOT101T1	
Z110	LD SMD-T-FILTER 100PF SMD-FILTER	1039.1356.00	MURATA	NFM61ROOT101T1	

MENP5

413 3PUA

AI

Datum
Date

Schalttailliste für
Parts list for

Sachnummer
Stock No.

Blatt-Nr.
Page

 **ROHDE & SCHWARZ**

31

16.09.97

EE SYNTHESIZER
SYNTHESIZER

1062.6409.01 SA

23+

für diese Unterlagen behalten
wir uns alle Rechte vor.

Kanz. Comp. No.	Benennung Designation	Sachnummer Stock No.	Hersteller Manufacturer	Bezeichnung Designation	enthalten in contained in	
Z180	LD SMD-T-FILTER 100PF SMD-FILTER	1039.1356.00	MURATA	NFM61ROOT101T1		
Z202	LD SMD-T-FILTER 3,3NF SMD-FILTER	1039.1362.00	MURATA	NFM61R20T332T1		
Z800	LD SMD-T-FILTER 33PF SMD-T-FILTER 33PF	1062.6744.00	MURATA	NFM61ROOT330		
Z801	LD SMD-T-FILTER 33PF SMD-T-FILTER 33PF	1062.6744.00	MURATA	NFM61ROOT330		
Z880	LD SMD-T-FILTER 100PF SMD-FILTER	1039.1356.00	MURATA	NFM61ROOT101T1		
Z882	LD SMD-T-FILTER 100PF SMD-FILTER	1039.1356.00	MURATA	NFM61ROOT101T1		
MENP5	413 3PUA	ÄI	Datum Date	Schaltteilliste für Parts list for	Sachnummer Stock No.	Blatt-Nr. Page
	31	16.09.97	EE SYNTHESIZER SYNTHESIZER	1062.6409.01 SA	24-	



XY-Liste

XY List

Erklärung der Spaltenbezeichnungen:

- Part:** Bauelement-Kennzeichen.
- Side:** Leiterplatten-Seite, auf der sich das Bauelement befindet.
- X/Y:** Koordinaten (Millimeter) des Bauelementes auf der Leiterplatte bezogen auf den Nullpunkt.
- SQR, PG:** Planquadrat und Seite des Schaltbildes für das jeweilige Bauelement.

Explanation of column designations:

- Part:** Identification of instrument part.
- Side:** Side of the PC board on which instrument part is positioned.
- X/Y:** Coordinates (millimeter) of the component on the PC board in reference to zero point.
- SQR, PG:** Square and page of the diagram for the respective instrument part.

Service-Relevante Bauteile / Service-Relevant Components																	
Part	Side	X	Y	Sqr	Pg	Part	Side	X	Y	Sqr	Pg	Part	Side	X	Y	Sqr	Pg
L346	B	250	20	8E	3	P600	B	161	107	7E	6	X20	B	270	123	12D	2
P20	B	78	20	4B	9	P610	B	229	119	11E	6	X75	B	71	137	10D	7
P21	B	88	30	6B	9	P700	B	199	138	5D	7	X80	B	168	45	2E	8
P201	B	285	44	4E	2	P720	B	144	139	7D	7	X84	B	78	71	9E	8
P202	B	291	64	7E	2	P840	B	164	69	5F	8	X124	B	19	15	11C	5
P203	B	282	88	10E	2	R930	B	119	89	8C	8	X125	B	258	15	11E	3
P204	B	274	72	8C	2	X1A	B	189	11	1E	8	X127	B	283	15	1D	2
P354	B	262	46	10C	3	X1D	B	189	11			X128	B	296	15	1D	2

Nicht-Service-Relevante Bauteile / Non-Service-Relevant Components																	
Part	Side	X	Y	Sqr	Pg	Part	Side	X	Y	Sqr	Pg	Part	Side	X	Y	Sqr	Pg
B360	B	253	50	7B	3	C230	A	297	96	10E	2	C361	A	257	51	8C	3
C1	B	112	24	2D	9	C232	B	273	16	2D	2	C370	B	252	44	8B	3
C2	B	157	23	2C	9	C234	B	296	21	2D	2	C373	A	262	36	9C	3
C3	B	145	24	2C	9	C235	B	296	27	2D	2	C400	A	34	138	1E	4
C4	B	102	22	2B	9	C236	B	299	81	3C	2	C402	B	21	141	1E	4
C5	B	145	17	2B	9	C240	A	276	17	5C	2	C404	A	13	114	2E	4
C20	A	69	22	3B	9	C245	B	286	80	8E	2	C406	B	23	112	2E	4
C21	A	80	17	4B	9	C250	A	276	127	11C	2	C408	B	24	115	2E	4
C25	A	88	16	5B	9	C252	B	286	137	11D	2	C410	B	19	105	3D	4
C26	A	80	27	6B	9	C254	A	291	123	11C	2	C412	B	23	104	3D	4
C27	A	80	31	6B	9	C255	A	293	133	10B	2	C414	B	23	95	3D	4
C30	A	100	45	4E	9	C256	B	273	140	11D	2	C416	A	34	100	3C	4
C31	A	152	43	4E	9	C258	A	270	125	12D	2	C418	A	12	125	2D	4
C32	B	246	71	6E	9	C260	A	279	127	11B	2	C425	A	18	86	3C	4
C33	A	150	87	6D	9	C261	A	283	137	11B	2	C430	A	40	133	5E	4
C34	A	72	89	6C	9	C286	B	282	120	11C	2	C432	B	49	136	5E	4
C35	A	122	50	3D	9	C300	B	253	118	2E	3	C434	A	40	113	6E	4
C36	A	272	86	7E	9	C302	B	259	110	2E	3	C436	B	49	112	6E	4
C100	A	195	69	4A	9	C304	B	255	105	2E	3	C438	B	49	115	6E	4
C110	B	200	59	10B	9	C306	B	250	98	3D	3	C440	B	44	105	7D	4
C120	A	195	54	3A	9	C308	B	254	97	3D	3	C442	B	48	104	7D	4
C200	A	280	41	5A	2	C310	A	262	91	3D	3	C444	B	48	95	7D	4
C202	A	284	57	2E	2	C312	A	245	90	3C	3	C446	A	57	100	7C	4
C204	A	295	49	2E	2	C314	A	259	89	3C	3	C448	A	61	125	5D	4
C205	A	297	20	2E	2	C316	B	254	88	4D	3	C455	A	44	88	7C	4
C206	A	300	36	3E	2	C320	A	258	74	4E	3	C490	A	58	77	4B	4
C208	B	294	42	3E	2	C324	B	254	75	5D	3	C491	A	47	79	4B	4
C210	A	294	69	6A	2	C331	B	254	56	5D	3	C492	B	37	95	9D	4
C214	A	276	72	6E	2	C335	B	246	51	7D	3	C493	B	37	82	9D	4
C217	B	275	31	5D	2	C336	B	246	27	8D	3	C494	A	27	81	9E	4
C218	B	275	28	6D	2	C338	A	243	32	7E	3	C500	B	37	75	1D	5
C219	B	288	19	6D	2	C342	A	259	27	9E	3	C501	B	37	62	2D	5
C220	A	293	89	7A	2	C344	B	258	24	9E	3	C502	A	28	66	2D	5
C221	A	297	89	7A	2	C345	B	250	32	7F	3	C505	A	55	67	1F	5
C222	A	271	35	6C	2	C346	B	247	20	8E	3	C506	A	12	58	2F	5
C224	A	269	74	7C	2	C347	B	252	15	9D	3	C507	A	31	46	2B	5
C225	A	271	42	7C	2	C348	A	247	13	10D	3	C510	B	29	55	3E	5
C227	A	271	51	7C	2	C349	A	247	17	10D	3	C511	A	18	48	3E	5
C228	A	272	54	7C	2	C360	B	259	53	7B	3	C512	A	18	55	3E	5

ROHDE & SCHWARZ	ÄI	Datum Date	XY-Liste für XY-list for	Sach-Nummer Stock-Nr	Blatt Page
	04	05.04.95	EE SYNTHESIZER SYNTHESIZER	1062.6409.01 XY	1+



Part	Side	X	Y	Sqr	Pg	Part	Side	X	Y	Sqr	Pg	Part	Side	X	Y	Sqr	Pg
C513	A	19	42	4E	5	C719	A	168	138	7B	7	C953	A	104	93	10D	8
C514	B	18	42	4E	5	C720	B	167	132	7D	7	C954	A	87	86	8C	8
C515	A	12	35	4E	5	C721	B	156	131	7D	7	C959	A	136	89	12C	8
C516	B	18	29	5E	5	C722	A	160	135	7D	7	C960	B	76	67	10E	8
C517	B	25	25	5E	5	C731	B	149	136	7C	7	C962	A	93	47	5D	8
C520	B	37	51	4C	5	C750	B	142	132	8D	7	C980	A	140	104	12B	8
C521	A	46	48	4C	5	C753	A	91	138	8D	7	C989	A	106	93	11B	8
C522	A	40	48	4C	5	C760	B	106	136	9D	7	C990	A	88	90	11B	8
C523	A	56	51	4C	5	C764	B	82	132	9C	7	C995	A	91	58	8F	8
C524	B	53	48	4C	5	C765	B	86	135	9C	7	D20	B	75	26	3B	9
C525	A	61	35	5D	5	C779	B	82	139	10D	7	D65A	B	197	86	8E	6
C526	B	49	35	5C	5	C780	A	130	131	8B	7	D110-A	B	224	60	8D	9
C527	B	46	31	6C	5	C781	A	133	138	8B	7	D110-B				4A	9
C530	A	31	43	5D	5	C782	A	116	130	10C	7	D115-A	B	220	55	8E	9
C532	B	25	35	5D	5	C784	A	101	132	11B	7	D115-B				5A	9
C550	B	42	22	9C	5	C786	A	107	138	10B	7	D125-A	B	210	62	3D	9
C551	B	27	18	10C	5	C787	A	184	135	5B	7	D125-B				8E	9
C552	A	20	20	10D	5	C788	A	244	136	3B	7	D125-C				10B	9
C553	A	12	23	10D	5	C789	A	252	140	3B	7	D125-D				10B	9
C555	B	24	12	10C	5	C790	A	252	135	3B	7	D125-E				5A	9
C556	A	41	11	10C	5	C791	A	252	130	3B	7	D200-A	B	283	39	6D	2
C557	A	52	11	11C	5	C792	A	201	132	6B	7	D200-B				5E	2
C570	A	34	39	8D	5	C793	A	220	138	5B	7	D200-C				5D	2
C571	A	61	30	8D	5	C800	A	175	59	3F	8	D200-D				6E	2
C580	A	55	13	11B	5	C830	B	182	48	2E	8	D200-E				5A	2
C600	B	70	94	2E	6	C840	B	109	72	8E	8	D205-A	B	283	67	5E	2
C601	B	73	108	2E	6	C841	A	116	69	7F	8	D205-B				8C	2
C602	A	68	109	2E	6	C842	A	127	64	6F	8	D205-C				5A	2
C604	B	146	111	6E	6	C843	A	177	70	5F	8	D210-A	B	297	67	7E	2
C605	B	79	114	3E	6	C844	A	128	73	6F	8	D210-B				7D	2
C610	A	91	122	3E	6	C845	A	167	68	5F	8	D210-C				6A	2
C615	B	97	114	4E	6	C846	B	124	62	6E	8	D215-A	B	279	87	9E	2
C616	B	110	114	4E	6	C850	A	126	59	6E	8	D215-B				6A	2
C620	A	124	111	4E	6	C860	B	233	40	3C	8	D220	B	288	105	2C	2
C621	A	119	114	4B	6	C861	B	231	32	3C	8	D255-A	B	291	135	10D	2
C625	B	118	108	5E	6	C862	A	233	30	4C	8	D255-B				10C	2
C630	A	141	111	5E	6	C865	A	230	36	5B	8	D255-C				10B	2
C631	A	135	114	4B	6	C866	A	210	33	5A	8	D510	B	23	52	3E	5
C633	B	132	108	6E	6	C870	A	218	17	5C	8	D520	B	43	53	4C	5
C640	A	151	118	6E	6	C871	A	225	20	5B	8	D585-A	A	46	18	11F	5
C645	A	166	114	3B	6	C884	A	216	28	5B	8	D585-B				11B	5
C650	A	166	103	10F	6	C885	A	224	15	5B	8	D620-A	B	116	114	4E	6
C655	A	225	114	5B	6	C890	B	95	62	4B	8	D620-B				4B	6
C661	A	181	86	10B	6	C891	B	93	70	5A	8	D630-A	B	132	114	5E	6
C662	A	173	103	7E	6	C892	B	171	60	3B	8	D630-B				4B	6
C690	A	195	88	9F	6	C893	B	168	53	3A	8	D640-A	B	170	108	7E	6
C691	A	185	99	9F	6	C911	A	150	60	5F	8	D640-B				1B	6
C692	A	197	112	9F	6	C913	B	150	62	5F	8	D640-C				5B	6
C693	A	209	99	9F	6	C940	B	85	96	8D	8	D640-D				7B	6
C698	A	167	87	6C	6	C941	A	91	100	9C	8	D640-E				3B	6
C701	B	232	131	4D	7	C942	A	97	99	9C	8	D655-A	B	223	116	11E	6
C702	A	232	138	4C	7	C949	B	81	83	9D	8	D655-B				6B	6
C705	B	259	129	2B	7	C950	B	86	83	8D	8	D655-C				5B	6
C710	A	204	133	5D	7	C951	B	88	101	8C	8	D660-A	B	232	85	2C	6
C712	A	212	130	4D	7	C952	A	105	100	9C	8	D660-B				2B	6

ROHDE & SCHWARZ	ÄI	Datum Date	XY-Liste für XY-list for	Sach-Nummer Stock-Nr	Blatt Page
		04 05.04.95	EE SYNTHESIZER SYNTHESIZER	1062.6409.01 XY	2+

Part	Side	X	Y	Sqr	Pg	Part	Side	X	Y	Sqr	Pg	Part	Side	X	Y	Sqr	Pg
D665-A	B	232	97	3C	6	L29	B	252	132	6D	9	N220-A	B	297	83	3C	2
D665-B				2B	6	L33	A	154	87	6D	9	N220-B				4C	2
D670-A	B	152	90	4C	6	L35	B	121	46	3D	9	N220-C				9E	2
D670-B				3B	6	L200	B	277	54	6E	2	N220-D				8E	2
D700-A	B	246	139	3D	7	L202	B	278	28	6D	2	N220-E				7A	2
D700-B				3C	7	L204	B	286	29	6D	2	N250-A	B	283	127	11D	2
D700-C				3B	7	L227	B	269	51	7C	2	N250-B				11B	2
D710-A	A	91	131	9C	7	L300	B	259	115	2E	3	N300	B	254	82	4D	3
D710-B				6B	7	L302	B	259	102	3D	3	N490	B	37	89	9D	4
D720-A	B	180	139	6E	7	L306	B	260	74	4E	3	N500	B	37	69	2D	5
D720-B				5B	7	L400	B	28	138	1E	4	N510	B	18	36	4E	5
D800-A	B	156	66	4E	8	L402	B	18	112	2E	4	N520	B	52	42	5C	5
D800-B				4E	8	L404	B	21	121	2E	4	N560	B	39	18	9C	5
D800-C				4D	8	L406	B	28	109	3D	4	N600	B	73	97	2E	6
D800-D				4E	8	L430	B	42	133	5E	4	N610	B	85	114	3E	6
D800-E				2B	8	L432	B	43	112	6E	4	N705	B	255	131	2B	7
D820-A	B	181	52	3E	8	L434	B	52	121	6D	4	N710-A	B	212	133	5D	7
D820-B				2B	8	L436	B	53	109	7D	4	N710-B				5B	7
D840	B	103	70	7E	8	L492	B	37	99	8D	4	N720-A	B	166	135	7D	7
D855-A	B	107	55	2C	8	L494	B	31	82	9D	4	N720-B				7B	7
D855-B				2B	8	L500	B	43	59	2D	5	N780-A	A	125	137	8B	7
D870-A	B	225	14	5C	8	L502	B	31	62	2D	5	N780-B				9B	7
D870-B				5C	8	L505	B	52	57	2F	5	N780-C				6B	7
D870-C				5A	8	L506	B	26	58	2E	5	N800-A	B	181	58	3F	8
D950-A	B	131	99	11D	8	L507	B	33	51	2C	5	N800-B				3B	8
D950-B				11D	8	L515	B	12	29	4E	5	N840-A	B	89	64	8E	8
D950-C				12B	8	L516	B	15	21	5E	5	N840-B				4B	8
D960-A	B	90	53	9F	8	L525	B	56	34	5C	5	N842-A	B	131	65	6F	8
D960-B				5D	8	L530	B	28	31	5D	5	N842-B				4B	8
D965-A	B	128	88	9C	8	L550	B	45	21	9C	5	N845-A	B	178	67	5E	8
D965-B				9B	8	L551	B	30	22	10C	5	N845-B				3B	8
D965-C				9B	8	L570	B	32	26	8D	5	N850-A	B	131	55	6E	8
D965-D				9C	8	L571	B	52	27	8C	5	N850-B				4B	8
K240-A	B	273	23	6D	2	L600	B	69	105	2E	6	N860-A	B	219	42	4C	8
K240-B				5B	2	L610	B	93	118	3E	6	N860-B				4C	8
K910-A	B	150	58	5F	8	L621	A	114	117	4B	6	N860-C				5A	8
K910-B				6D	8	L631	A	131	117	4B	6	N940-A	B	91	99	9C	8
L1	B	116	20	2D	9	L645	A	163	114	3B	6	N940-B				11B	8
L2	B	155	18	2C	9	L655	A	222	110	5B	6	N950-A	B	104	99	9C	8
L3	B	142	20	2C	9	L695	A	166	98	6D	6	N950-B				10C	8
L4	B	101	15	2C	9	L800	A	165	43	2E	8	N950-C				8C	8
L5	B	142	15	2B	9	L801	A	161	43	2E	8	N950-D				8B	8
L6	A	273	89	6E	9	N20-A	B	81	20	4B	9	N950-E				11B	8
L8	A	270	102	6E	9	N20-B				5B	9	N960-A	B	114	103	10D	8
L9	B	246	79	6E	9	N20-C				3A	9	N960-B				11B	8
L12	A	91	86	6D	9	N100-A	B	210	51	10E	9	R5	B	137	25	2B	9
L13	A	218	131	6D	9	N100-B				10E	9	R20	B	75	16	4B	9
L14	A	107	46	4E	9	N100-C				3A	9	R21	A	79	22	3B	9
L15	A	248	71	6E	9	N105-A	B	198	51	10D	9	R22	A	74	15	4B	9
L18	B	71	88	6D	9	N105-B				10C	9	R23	A	74	17	4B	9
L19	A	145	43	4E	9	N105-C				3A	9	R24	A	83	22	5B	9
L20	A	299	79	6E	9	N110-A	B	192	69	9C	9	R25	A	83	29	5B	9
L22	A	110	86	6D	9	N110-B				9B	9	R26	B	79	12	5B	9
L23	A	190	137	6D	9	N110-C				4A	9	R27	B	88	12	5B	9
L28	A	180	135	6D	9	N200	B	297	52	2E	2	R28	A	86	22	6B	9

ROHDE & SCHWARZ	ÄI	Datum Date	XY-Liste für XY-list for	Sach-Nummer Stock-Nr	Blatt Page
		04 05.04.95	EE SYNTHESIZER SYNTHESIZER	1062.6409.01 XY	3+

Part	Side	X	Y	Sqr	Pg	Part	Side	X	Y	Sqr	Pg	Part	Side	X	Y	Sqr	Pg
R29	A	89	22	6B	9	R224	A	276	39	5D	2	R326	B	254	69	5D	3
R30	A	270	129	6F	9	R225	B	271	34	5D	2	R328	B	260	65	5D	3
R31	B	144	128	6D	9	R226	A	282	38	6E	2	R330	B	251	61	5D	3
R100	A	199	72	4A	9	R227	B	272	44	7E	2	R331	B	254	63	5D	3
R110	B	187	24	2E	9	R228	A	280	54	7D	2	R332	B	260	59	5D	3
R111	B	187	39	3E	9	R229	A	273	34	6C	2	R335	B	247	54	7D	3
R112	B	192	24	2E	9	R230	A	290	94	10E	2	R336	B	247	24	8D	3
R113	B	192	39	3E	9	R232	A	300	98	10E	2	R337	B	244	30	8D	3
R114	B	177	24	2E	9	R234	A	298	23	1E	2	R338	A	243	34	7D	3
R115	B	177	39	3E	9	R236	A	271	24	6C	2	R339	A	245	26	8E	3
R116	B	171	24	2D	9	R238	A	275	44	7C	2	R340	A	250	21	8E	3
R117	B	171	39	3D	9	R239	A	274	81	7D	2	R341	A	253	21	8E	3
R118	A	196	24	2F	9	R240	A	270	58	7C	2	R342	A	262	28	8E	3
R119	B	197	39	3F	9	R241	A	299	65	7E	2	R343	A	252	25	8E	3
R120	A	192	48	3A	9	R242	A	297	66	7E	2	R344	A	257	27	8F	3
R125	A	207	63	3D	9	R243	B	298	78	8E	2	R345	A	252	32	7F	3
R142	A	219	62	8D	9	R244	B	283	80	8D	2	R346	B	253	27	8D	3
R144	A	210	48	5A	9	R245	B	293	81	8E	2	R347	B	247	16	9D	3
R145	A	207	65	8E	9	R246	A	290	89	8E	2	R348	A	250	13	10D	3
R146	A	226	52	9E	9	R247	B	288	68	8E	2	R361	A	253	53	8C	3
R150	A	207	51	10F	9	R248	B	280	83	8D	2	R370	B	259	44	9B	3
R152	A	210	53	10E	9	R251	A	271	111	2C	2	R371	B	262	41	9C	3
R154	A	204	53	10E	9	R253	A	274	105	2C	2	R372	B	255	37	9C	3
R156	A	197	51	10D	9	R255	A	281	108	2B	2	R373	A	256	40	9C	3
R158	A	198	57	10D	9	R258	B	292	97	3C	2	R375	B	252	41	8B	3
R160	A	192	54	10C	9	R260	B	298	99	4B	2	R400	A	31	132	1E	4
R162	A	198	66	9B	9	R264	B	285	97	4C	2	R402	A	19	110	2E	4
R164	A	192	69	9C	9	R266	B	275	94	5C	2	R404	B	12	112	2E	4
R166	A	190	66	9B	9	R267	B	269	94	5C	2	R406	B	15	122	2D	4
R167	A	193	62	9B	9	R269	B	278	97	5B	2	R408	A	13	128	2D	4
R170	A	188	56	11D	9	R270	B	198	23	5B	2	R410	B	21	108	3E	4
R172	A	187	62	10C	9	R276	A	297	137	10D	2	R412	B	16	105	3D	4
R174	A	204	66	10B	9	R277	A	291	134	10D	2	R414	A	19	99	3D	4
R178	B	207	59	10B	9	R278	B	294	118	10D	2	R416	A	16	95	2D	4
R180	B	182	42	11C	9	R280	B	287	130	10D	2	R418	A	26	97	3D	4
R181	B	182	27	11C	9	R281	B	284	135	11D	2	R420	A	34	106	3D	4
R201	A	283	44	5B	2	R282	A	294	126	10C	2	R422	B	23	101	3D	4
R202	A	295	42	3E	2	R283	B	287	123	11C	2	R424	B	29	96	3D	4
R204	A	300	29	1E	2	R284	B	278	135	11D	2	R425	A	20	86	3C	4
R206	B	292	36	3E	2	R285	B	273	130	11D	2	R426	A	28	90	3C	4
R207	B	297	33	3E	2	R286	B	282	117	11C	2	R427	A	31	92	4C	4
R208	A	290	36	3E	2	R287	B	276	120	12C	2	R430	A	40	131	5E	4
R209	A	294	62	6B	2	R288	A	281	123	11D	2	R431	B	48	121	6E	4
R210	B	297	40	3D	2	R289	A	284	123	11C	2	R432	A	37	113	6E	4
R212	B	288	41	3E	2	R290	A	294	140	10B	2	R434	B	38	112	6E	4
R213	B	290	34	4E	2	R291	A	281	133	11B	2	R436	B	57	124	6D	4
R214	A	292	33	4E	2	R302	B	253	101	3D	3	R438	A	59	129	6D	4
R215	B	280	78	5D	2	R304	B	247	98	3D	3	R440	B	47	108	7E	4
R216	A	285	35	4F	2	R306	B	244	92	2D	3	R442	B	41	105	7D	4
R218	B	297	29	2D	2	R308	A	250	94	3D	3	R444	A	44	99	7D	4
R219	B	292	30	2D	2	R310	B	262	98	3D	3	R446	A	41	94	6D	4
R220	A	275	59	7C	2	R312	A	252	86	3C	3	R448	A	50	99	7D	4
R221	A	285	64	5E	2	R314	B	254	94	3D	3	R450	A	59	106	7D	4
R222	A	274	66	7C	2	R316	A	258	67	4E	3	R452	B	48	102	7D	4
R223	A	276	78	8C	2	R324	B	260	70	5D	3	R454	B	44	92	7D	4

ROHDE & SCHWARZ	AI	Datum Date	XY-Liste für XY-list for	Sach-Nummer Stock-Nr	Blatt Page
		04 05.04.95	EE SYNTHESIZER SYNTHESIZER	1062.6409.01 XY	4+

Part	Side	X	Y	Sqr	Pg	Part	Side	X	Y	Sqr	Pg	Part	Side	X	Y	Sqr	Pg
R455	A	44	90	7C	4	R637	B	223	119	11E	6	R705	B	252	129	2B	7
R456	A	55	90	7C	4	R638	A	217	117	11E	6	R706	B	205	130	5D	7
R457	A	55	92	8C	4	R639	A	219	114	11E	6	R707	A	237	135	3C	7
R483	B	34	78	10D	4	R640	A	145	118	6F	6	R708	B	223	137	4C	7
R490	A	57	75	4B	4	R643	B	149	110	6E	6	R709	B	258	140	2B	7
R491	A	21	81	9E	4	R644	B	151	117	6E	6	R710	B	216	137	5C	7
R495	B	48	75	11D	4	R645	B	155	107	6E	6	R712	A	209	140	4E	7
R496	B	39	75	10D	4	R647	A	168	107	7E	6	R713	A	208	133	4D	7
R497	B	42	79	10D	4	R650	A	189	88	8F	6	R719	A	164	132	7B	7
R499	B	31	75	11D	4	R651	A	189	91	8F	6	R720	A	180	141	5E	7
R500	B	43	65	2D	5	R652	A	189	93	8F	6	R721	B	191	135	6E	7
R502	A	22	62	2E	5	R653	A	188	96	8F	6	R722	B	191	137	6E	7
R505	B	52	67	1F	5	R654	A	200	121	7D	6	R723	B	191	140	6D	7
R506	B	19	58	2E	5	R655	B	177	99	8E	6	R724	B	191	132	6D	7
R507	B	27	50	2C	5	R656	A	170	112	1B	6	R725	B	175	140	6D	7
R510	A	33	50	3E	5	R658	A	187	84	10B	6	R726	B	175	129	6D	7
R511	A	16	42	4E	5	R659	A	165	118	5B	6	R727	B	175	138	6D	7
R515	A	15	26	4F	5	R660	A	205	96	7E	6	R728	B	175	131	6D	7
R520	A	45	63	4D	5	R661	A	205	93	7E	6	R729	B	175	134	6D	7
R521	A	57	53	4C	5	R662	A	175	103	7E	6	R730	B	167	130	7D	7
R525	B	40	35	6C	5	R663	A	160	114	7B	6	R733	A	159	128	7D	7
R526	B	43	31	6C	5	R664	A	202	107	7D	6	R750	B	135	135	8D	7
R527	B	40	31	6C	5	R665	A	204	107	7D	6	R751	B	129	135	8D	7
R528	A	59	41	5D	5	R666	A	207	107	7D	6	R752	A	99	140	8D	7
R530	B	31	42	5D	5	R667	A	188	105	7D	6	R753	A	89	138	8D	7
R531	B	29	42	5E	5	R668	A	176	106	7D	6	R762	B	112	136	9D	7
R550	B	44	15	9C	5	R669	A	188	107	7D	6	R763	B	103	136	9D	7
R552	A	23	23	10D	5	R670	A	176	109	7D	6	R764	B	97	136	9D	7
R555	B	37	11	10B	5	R671	A	188	110	7C	6	R777	B	73	140	10D	7
R556	B	37	13	10C	5	R672	A	176	111	7C	6	R780	A	139	131	8B	7
R557	A	45	15	10C	5	R673	A	188	112	7C	6	R781	A	133	131	8B	7
R570	B	32	32	8D	5	R674	A	176	114	7C	6	R782	A	128	138	8B	7
R571	B	52	30	8D	5	R675	A	178	121	7C	6	R783	A	107	135	10B	7
R579	A	60	18	11B	5	R676	A	184	121	7C	6	R784	A	104	132	10B	7
R581	A	58	15	11F	5	R677	A	187	121	7C	6	R785	A	116	137	9B	7
R600	B	145	108	6E	6	R678	A	189	121	7C	6	R786	A	114	140	9B	7
R603	A	72	115	2F	6	R679	A	192	121	7C	6	R787	A	177	128	5B	7
R605	B	70	114	2E	6	R680	A	194	121	7C	6	R792	A	193	137	6B	7
R606	B	79	120	3E	6	R681	A	191	109	7B	6	R793	A	216	134	6B	7
R607	B	73	117	2E	6	R686	A	222	85	1C	6	R800	A	169	48	2E	8
R610	A	84	120	3F	6	R687	A	225	98	3C	6	R802	B	167	65	3E	8
R611	A	235	109	6B	6	R688	A	142	89	4C	6	R803	A	165	46	2E	8
R612	A	235	111	6B	6	R690	A	199	94	9F	6	R804	A	175	45	2E	8
R613	A	234	114	6B	6	R691	A	190	102	9F	6	R812	B	164	54	2E	8
R614	A	234	116	6B	6	R692	A	194	107	9F	6	R813	B	184	61	3E	8
R615	B	102	120	4E	6	R693	A	203	102	9F	6	R820	A	175	54	2B	8
R616	B	106	114	4E	6	R695	A	166	94	5D	6	R821	A	175	50	2A	8
R617	B	108	117	4E	6	R696	A	170	91	5D	6	R822	A	168	64	2B	8
R620	A	121	121	4E	6	R697	A	157	87	6D	6	R823	A	160	61	2A	8
R621	A	123	121	4E	6	R698	A	163	87	6D	6	R824	A	169	58	3B	8
R630	A	137	121	5E	6	R700	A	249	141	3D	7	R825	A	180	65	3A	8
R631	A	140	121	5E	6	R701	A	247	138	3D	7	R826	A	171	64	3B	8
R633	B	139	108	6E	6	R702	B	245	128	3D	7	R827	A	177	72	3A	8
R635	B	173	116	7F	6	R703	B	235	137	3D	7	R828	A	123	71	4B	8
R636	B	177	103	10E	6	R704	B	211	130	4D	7	R829	A	133	68	4A	8

ROHDE & SCHWARZ	ÄI	Datum Date	XY-Liste für XY-list for	Sach-Nummer Stock-Nr	Blatt Page
		04 05.04.95	EE SYNTHESIZER SYNTHESIZER	1062.6409.01 XY	5+

Part	Side	X	Y	Sqr	Pg	Part	Side	X	Y	Sqr	Pg	Part	Side	X	Y	Sqr	Pg
R830	A	130	53	4B	8	R956	B	114	83	8C	8	V402	B	23	120	2E	4
R831	A	133	61	4A	8	R957	A	107	106	9D	8	V403	B	24	120	2E	4
R832	A	85	64	4B	8	R958	A	101	93	10D	8	V404	B	26	106	3E	4
R833	A	92	72	5A	8	R960	B	76	64	10E	8	V406	A	34	108	3D	4
R834	A	98	70	5A	8	R961	B	73	62	10D	8	V408	A	32	95	4C	4
R835	A	98	59	4B	8	R962	B	73	59	10D	8	V410	A	23	90	3C	4
R836	A	165	55	3B	8	R963	B	81	59	10E	8	V430	B	50	122	5D	4
R837	B	164	51	3A	8	R964	B	79	56	10E	8	V431	B	48	122	5E	4
R840	A	121	64	7E	8	R965	B	81	52	11E	8	V432	B	50	120	6D	4
R841	A	120	67	7E	8	R966	B	79	49	11E	8	V433	B	48	120	6E	4
R842	A	121	62	7E	8	R967	B	81	45	11E	8	V434	B	51	106	7E	4
R843	B	177	65	5F	8	R968	B	79	41	11E	8	V436	A	59	108	7D	4
R844	A	130	64	6E	8	R969	B	73	57	10D	8	V438	A	56	95	8C	4
R845	A	183	72	5E	8	R970	B	73	53	11D	8	V440	A	50	90	7C	4
R846	B	103	72	8E	8	R971	B	73	49	11D	8	V480	A	55	85	4B	4
R847	A	121	57	7F	8	R972	B	73	44	11D	8	V490	B	39	94	8D	4
R848	B	134	72	6F	8	R973	B	73	42	11D	8	V492	B	34	96	7C	4
R849	B	127	73	6F	8	R974	B	73	39	12D	8	V500	B	49	59	2E	5
R850	A	101	72	6E	8	R975	B	73	37	12D	8	V501	B	32	56	2E	5
R851	B	131	62	6E	8	R980	A	140	99	12B	8	V502	B	38	53	2D	5
R853	A	127	62	6E	8	R986	A	109	90	11B	8	V510	A	27	47	3E	5
R857	A	120	53	2C	8	R987	A	91	93	11B	8	V520	A	47	56	4D	5
R860	A	233	27	4C	8	R990	A	86	46	9F	8	V532	B	21	28	5E	5
R861	B	204	37	3C	8	R991	A	94	43	5D	8	V550	B	42	27	8C	5
R862	B	211	37	4C	8	R993	A	97	54	5D	8	V551	B	37	24	8C	5
R863	B	214	32	4B	8	R994	A	78	59	8E	8	V553	B	51	23	9C	5
R864	A	229	25	4B	8	R995	A	89	54	8F	8	V555	B	29	12	10C	5
R865	A	223	39	5B	8	R996	A	84	51	8F	8	V600	B	150	106	6E	6
R866	A	213	37	5A	8	V20	B	85	26	6B	9	V695	A	157	89	6D	6
R870	B	231	13	5C	8	V110	B	199	62	11C	9	V696	B	173	94	5D	6
R871	A	210	15	5C	8	V120	A	216	44	5A	9	V700	B	239	128	3D	7
R872	A	212	22	5B	8	V200	A	285	51	2E	2	V719	A	166	132	7B	7
R873	A	234	19	5B	8	V205	B	295	40	3E	2	V750	B	132	133	8D	7
R874	B	231	15	5C	8	V210	B	285	35	4E	2	V755	B	132	140	8D	7
R875	A	212	24	5C	8	V212	A	279	36	6E	2	V757	B	147	139	8D	7
R880	B	214	14	5C	8	V215	A	271	49	7C	2	V765	B	102	138	9D	7
R881	B	198	13	6C	8	V216	A	270	68	7C	2	V766	B	110	140	9E	7
R882	B	214	18	5B	8	V220	A	269	30	6B	2	V767	B	112	130	9D	7
R883	B	198	18	6B	8	V235	B	300	24	2D	2	V768	B	114	129	9C	7
R884	A	223	30	5B	8	V240	A	278	21	5B	2	V780	A	111	137	10B	7
R885	A	221	23	5B	8	V245	A	279	89	9E	2	V781	A	114	134	10B	7
R931	B	114	96	8C	8	V247	B	285	74	8E	2	V787	A	180	128	5B	7
R932	A	114	89	8C	8	V255	B	293	124	10D	2	V800	A	153	50	2E	8
R933	A	114	98	8B	8	V260	A	278	136	11B	2	V902	A	140	60	6D	8
R938	A	97	84	8C	8	V265	A	275	121	12D	2	V946	B	100	91	10D	8
R939	A	104	84	8C	8	V300	B	257	115	2E	3	V947	B	100	87	10D	8
R940	B	86	90	8D	8	V305	B	256	99	3E	3	V951	A	99	102	9D	8
R943	A	131	100	11D	8	V310	A	256	91	3C	3	V952	A	102	104	9D	8
R949	A	133	100	11D	8	V330	B	247	29	8D	3	V955	A	78	53	9E	8
R950	B	83	83	8D	8	V340	A	247	24	8E	3	V960	A	77	45	9E	8
R951	B	85	98	8D	8	V345	A	262	20	8E	3	V961	A	90	50	5D	8
R952	B	108	84	8C	8	V347	B	247	11	9D	3	X300	B	248	109	2D	3
R953	B	92	89	8C	8	V370	B	258	41	9B	3	Z1	B	116	30	2D	9
R954	A	111	93	8C	8	V400	B	23	122	2E	4	Z2	B	146	30	2C	9
R955	A	93	93	8C	8	V401	B	24	122	2E	4	Z3	B	141	30	2C	9

ROHDE & SCHWARZ	ÄI	Datum Date	XY-Liste für XY-list for	Sach-Nummer Stock-Nr	Blatt Page
		04 05.04.95	EE SYNTHESIZER SYNTHESIZER	1062.6409.01 XY	6+

Part	Side	X	Y	Sqr	Pg	Part	Side	X	Y	Sqr	Pg	Part	Side	X	Y	Sqr	Pg
Z4	B	110	30	2C	9	Z12	B	68	74	5C	9	Z180	B	182	36	11C	9
Z5	B	136	30	2B	9	Z13	B	68	43	5C	9	Z202	B	201	23	5B	2
Z6	B	99	28	2B	9	Z14	B	68	53	5C	9	Z800	B	166	30	1E	8
Z7	B	237	74	5E	9	Z102	B	187	30	2E	9	Z801	B	161	30	1E	8
Z8	B	237	69	5E	9	Z104	B	192	30	2E	9	Z880	B	208	13	6C	8
Z9	B	72	75	5D	9	Z106	B	177	30	2E	9	Z882	B	208	18	6B	8
Z10	B	237	58	5E	9	Z108	B	171	30	2D	9						
Z11	B	154	75	5D	9	Z110	B	197	30	2F	9						

ROHDE & SCHWARZ	ÄI	Datum Date	XY-Liste für XY-list for	Sach-Nummer Stock-Nr	Blatt Page
	04	05.04.95	EE SYNTHESIZER SYNTHESIZER	1062.6409.01 XY	7-

Stromläufe
Bestückungspläne
Circuit diagrams
Components plans
Schémas de circuit
Plans des composants

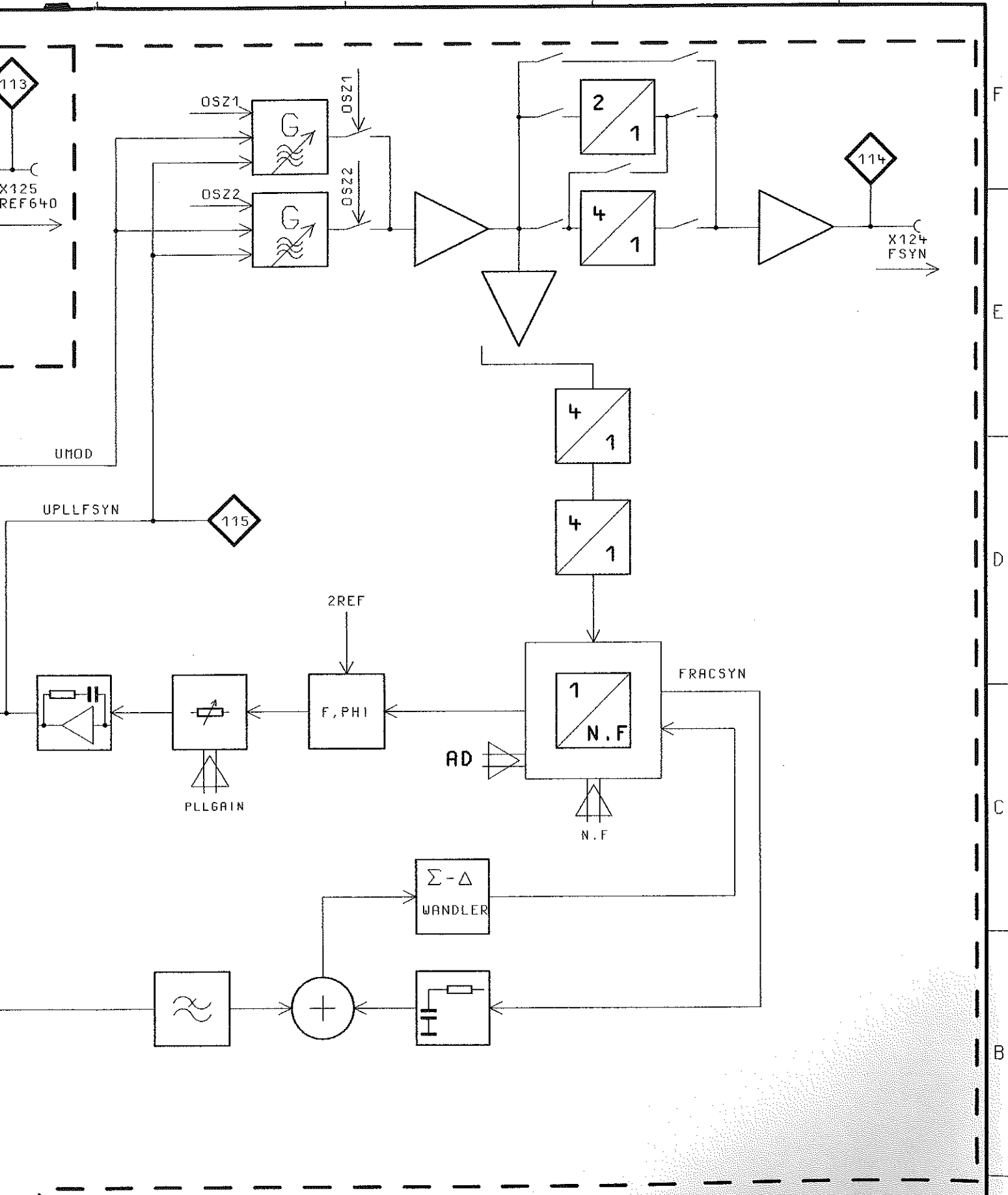

04/02		21.02.97	E I	MENP	TAG	NAME	BENENNUNG
				BEARB.		E I	SYNTHESIZER SYNTHESIZER
				GEPR.			
				NORM			
				PLOTT	21.02.97		
04/01		02.12.96	WH	 ROHDE & SCHWARZ			ZEICHN. - NR.
REND. IND.	RENDERUNGS- MITTEILUNG	DATUM	NAME	ZU GERÄT	SMY	1062.6409.01S	REG.-NR. 1062.5502 ERSTE Z. 1062.5502
							BLATT-NR. 1+ v. 16 Bl.

F
E
D
C
B
A

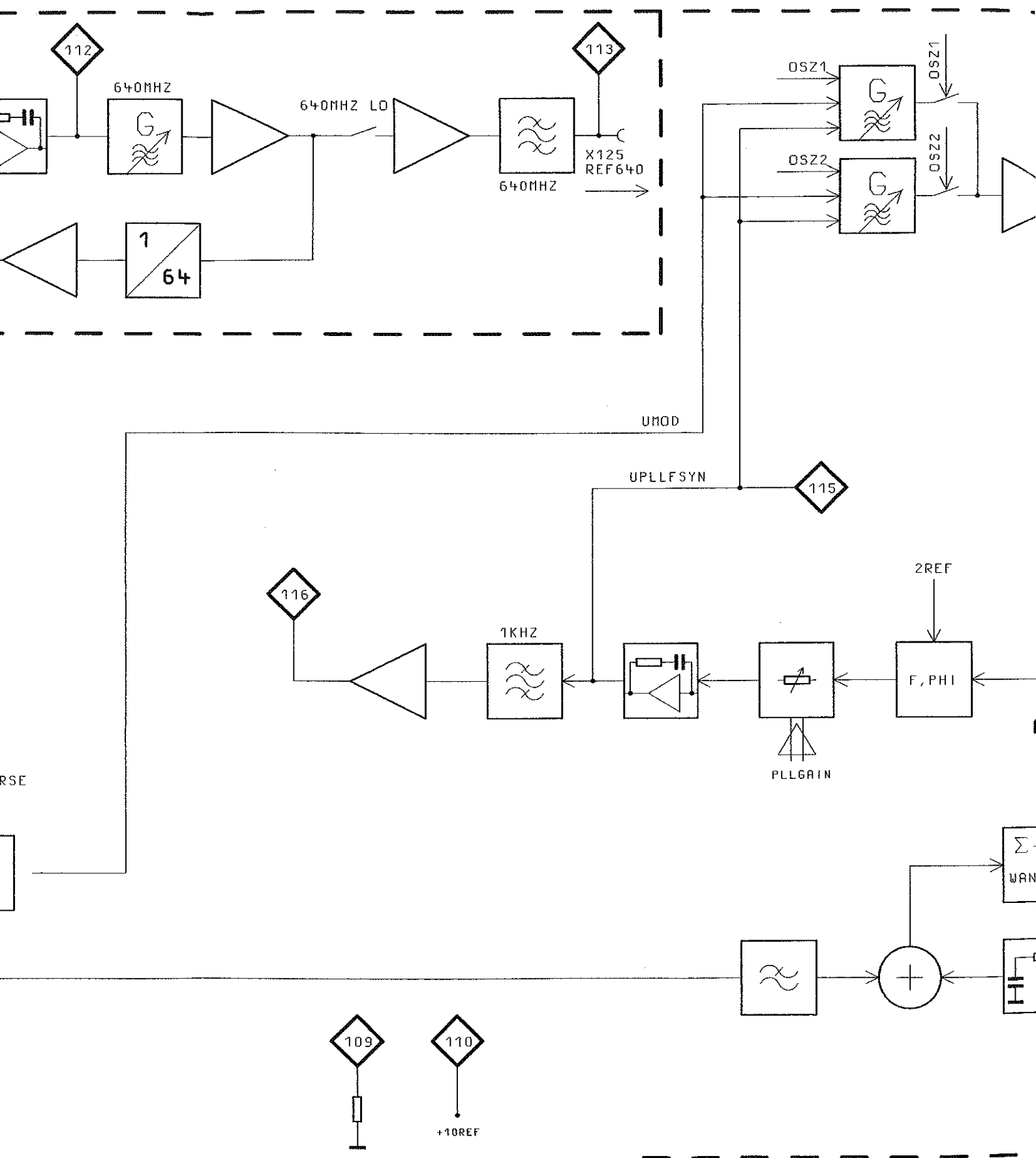

ANGABEN ÜBER VARIANTEN,
BAUTEILWERTE UND
GEHECKTE BAUTEILE SIEHE SA.
FÜR WEITERE INFORMATION ON MODELS,
PARTS AND COMPONENTS VALUES AND
COMPONENTS SEE PARTS LIST.

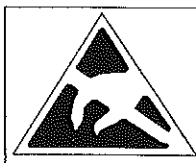

ACHTUNG: EGB!
ELEKTROSTATISCH GEFÄHRDETE
BAUELEMENTE ERFORDERN EINE
BESONDERE HANDHABUNG.
ATTENTION ESD!
ELECTROSTATIC SENSITIVE DEVICES
REQUIRE A SPECIAL HANDLING

04/02		21.02.97	E I	MENP	TAG
				BEARB.	
				GEPR.	
				NORN	
				PLOTT	21.02.
04/01		02.12.96	WH		
REND. IND.	RENDERUNGS- MITTEILUNG	DATUM	NAME		
				ROHDE&SCHWARZ	
				ZU GERÄT	S

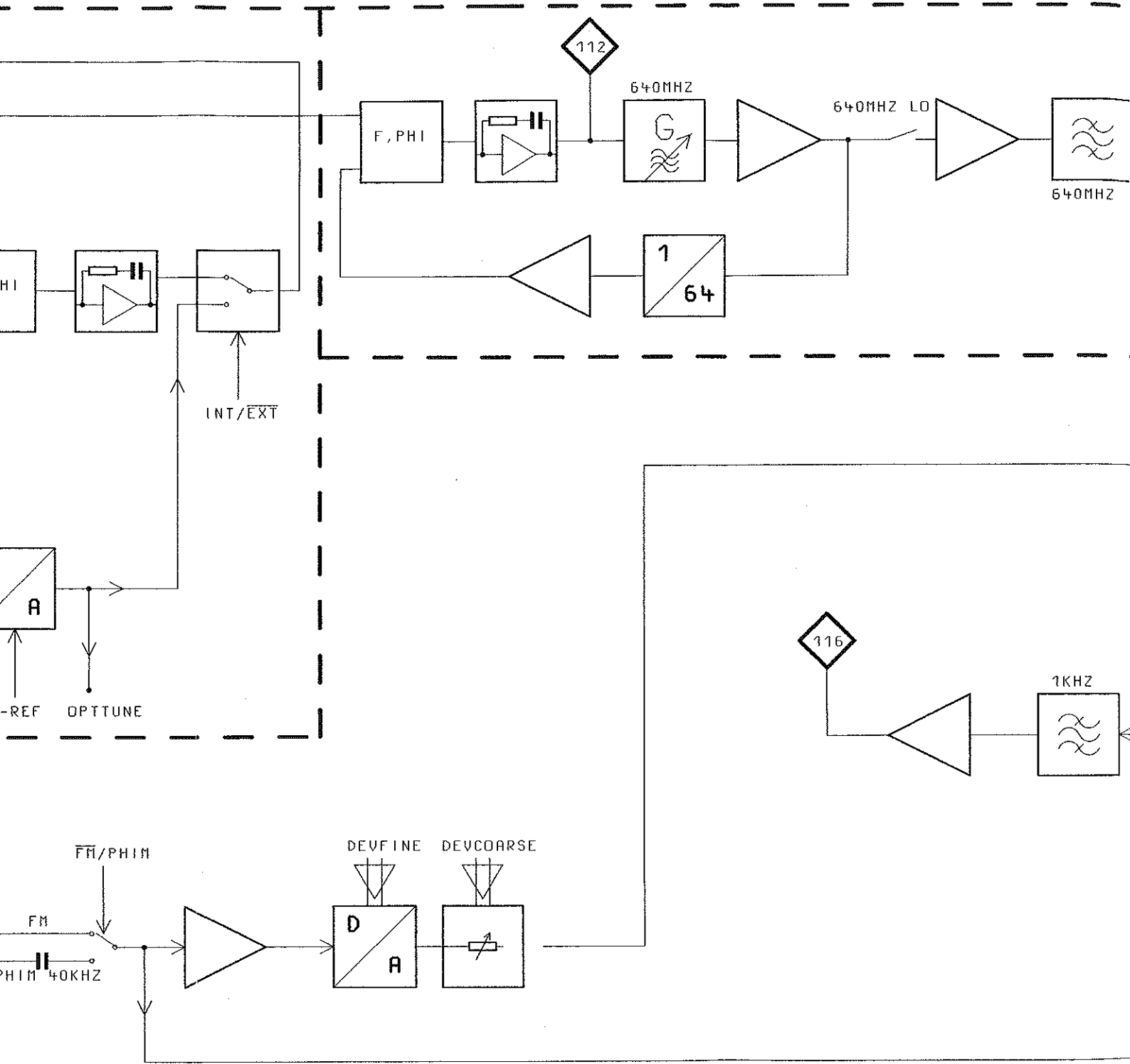

BINDENDE ANGABEN UEBER VARIANTEN,
TRIMMWERTE, BAUTEILWERTE UND
NICHT BESTUECKTE BAUTEILE SIEHE SA.
FOR BINDING INFORMATION ON MODELS,
TRIMMING AND COMPONENTS VALUES AND
NONFITTED COMPONENTS SEE PARTS LIST.

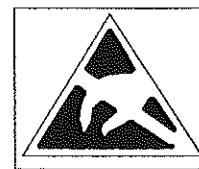

ACHTUNG: EGB!
ELEKTROSTATISCH GEFAHRDETE
BAUELEMENTE ERFORDERN EINE
BESONDERE HANDHABUNG.
ATTENTION ESD!
ELECTROSTATIC SENSITIVE DEVICES
REQUIRE A SPECIAL HANDLING

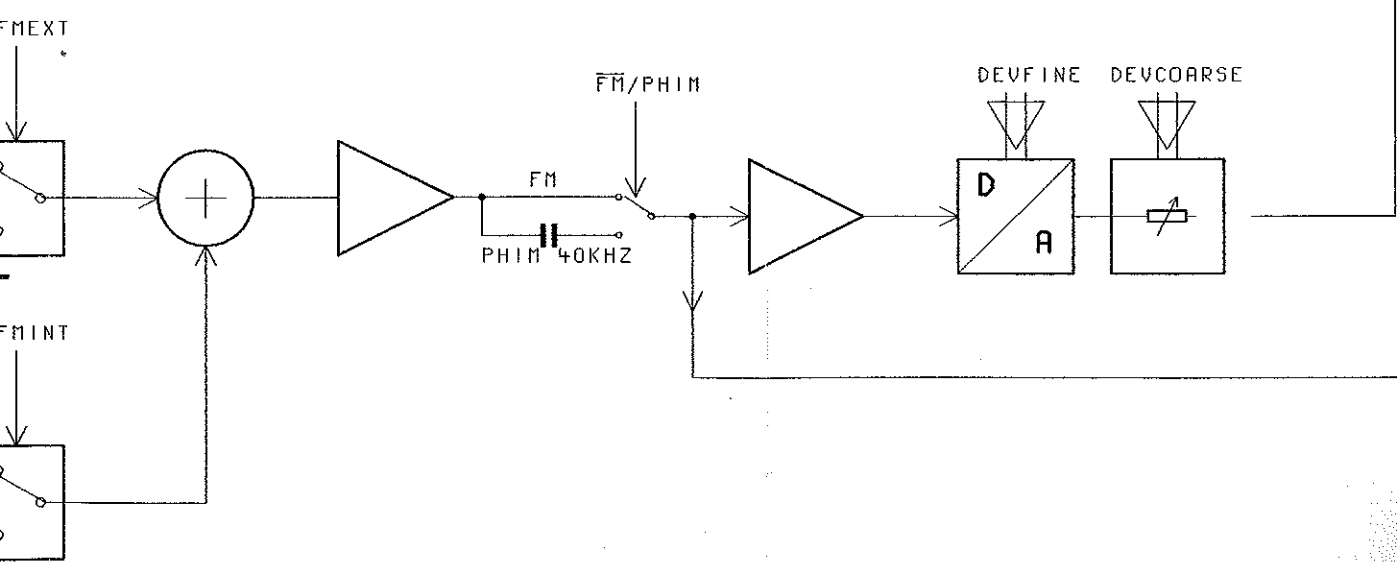
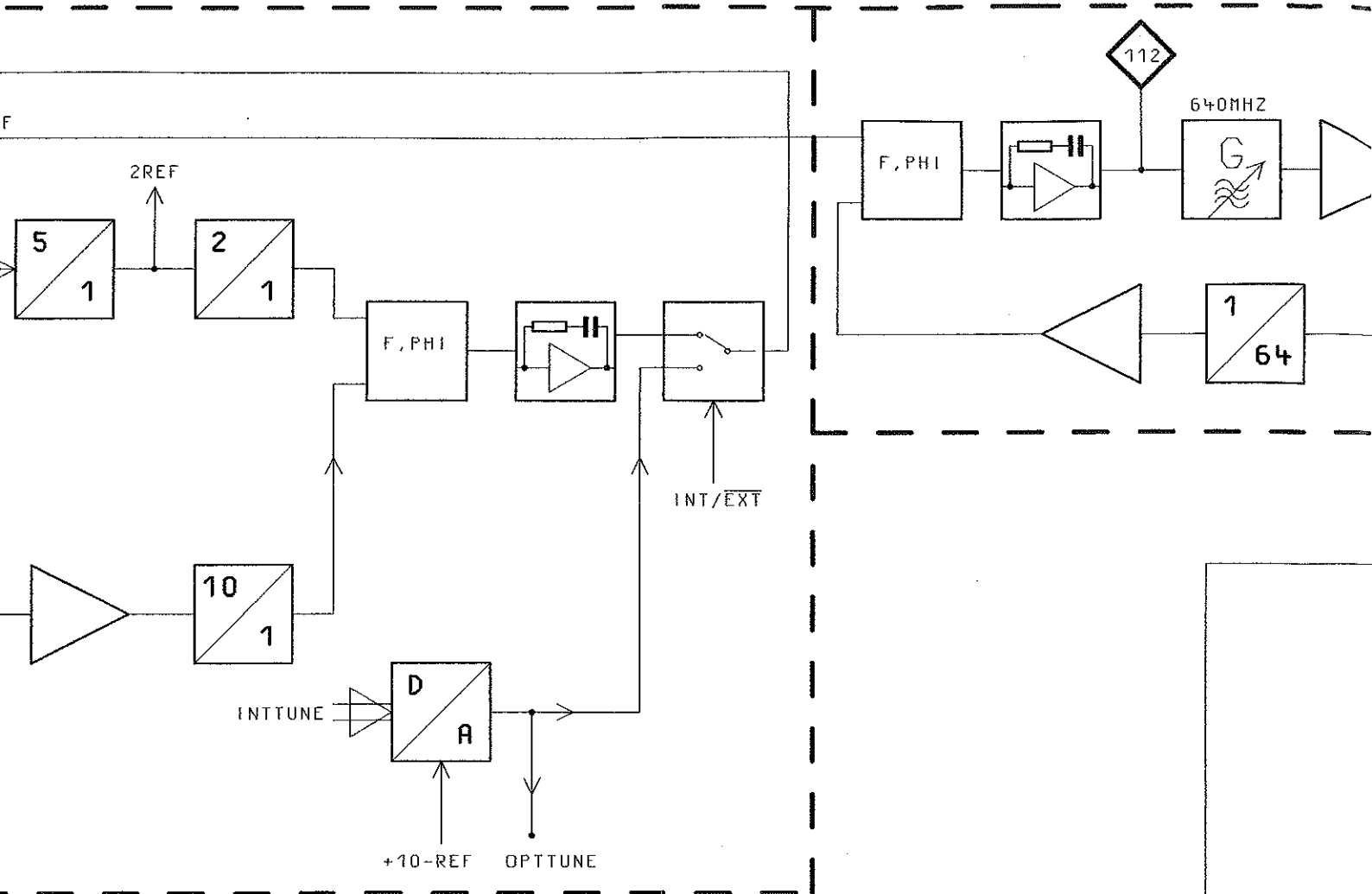

BINDENDE ANGABEN UEBER VARIANTEN,
 TRIMMWERTE, BAUTEILWERTE UND
 NICHT BESTUECKTE BAUTEILE SIEHE SA.
 FOR BINDING INFORMATION ON MODELS,
 TRIMMING AND COMPONENTS VALUES AND
 NONFITTED COMPONENTS SEE PARTS LIST.

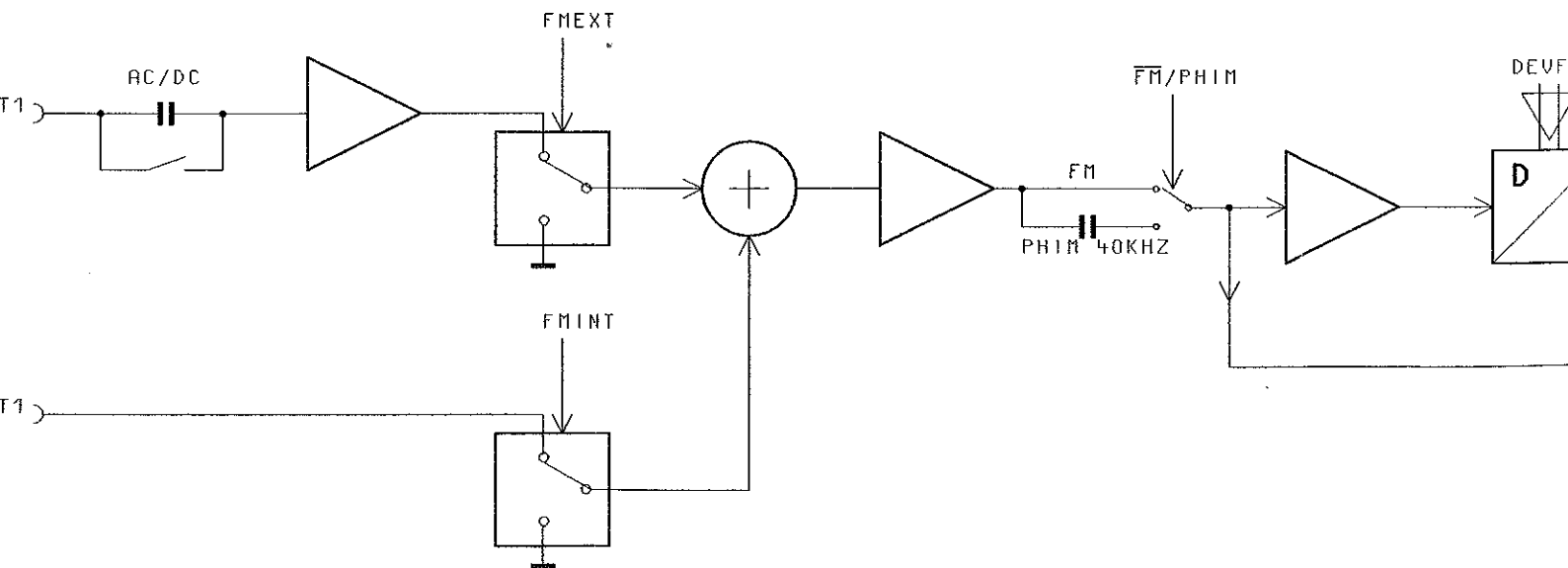
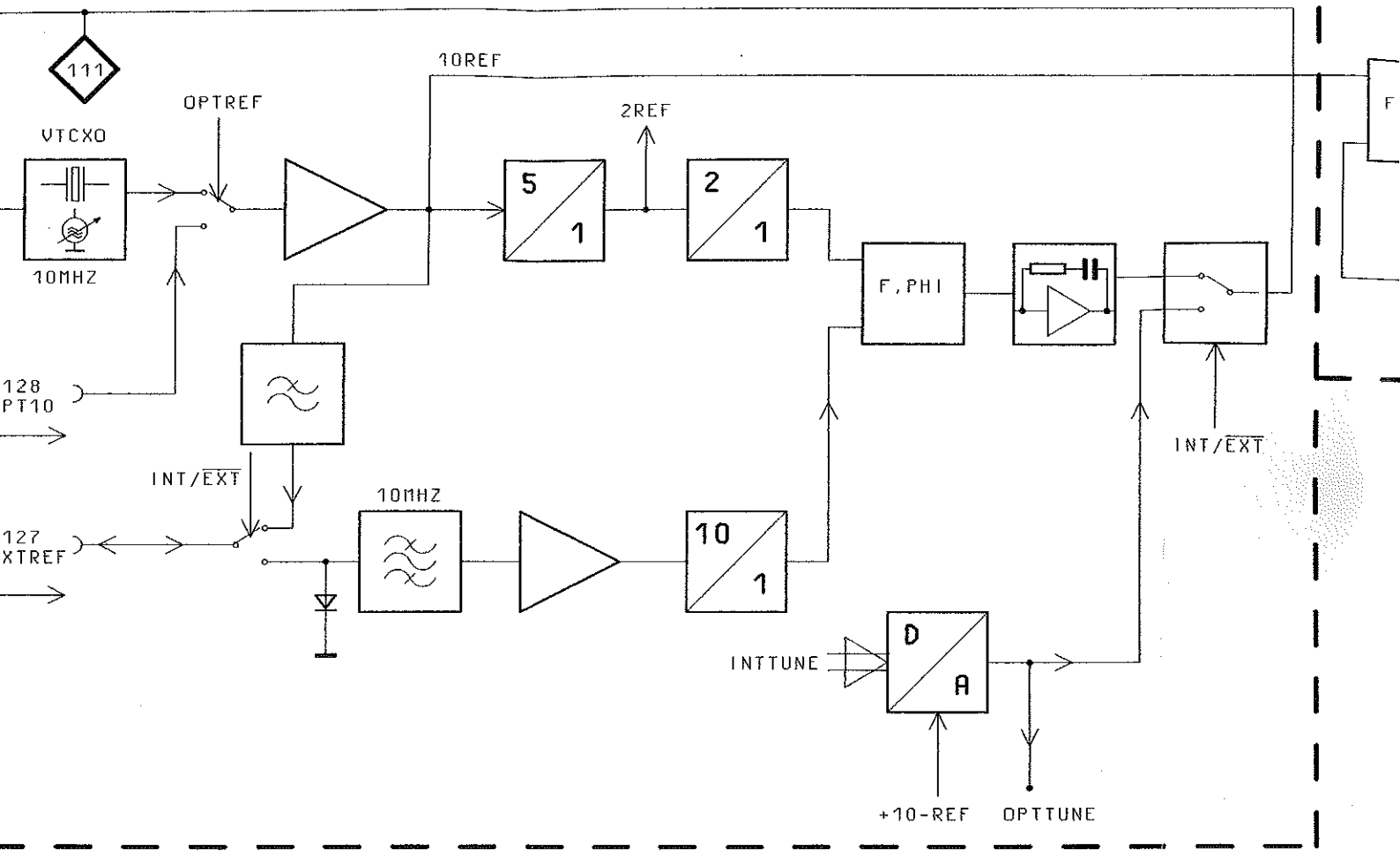

FUER DIESE UNTERLAGE
BEHALTEN MIR UNS ALLE RECHTE VOR

ZEICHN.-NR. 062.6409.01 S

F
E
D
C
B
A

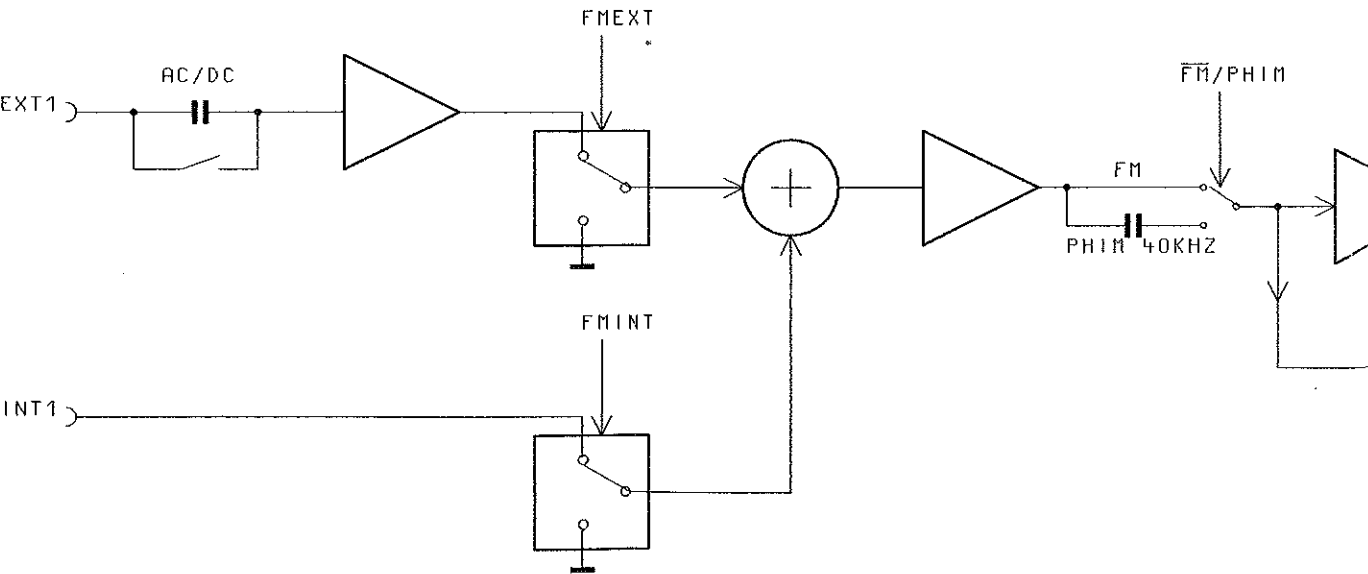
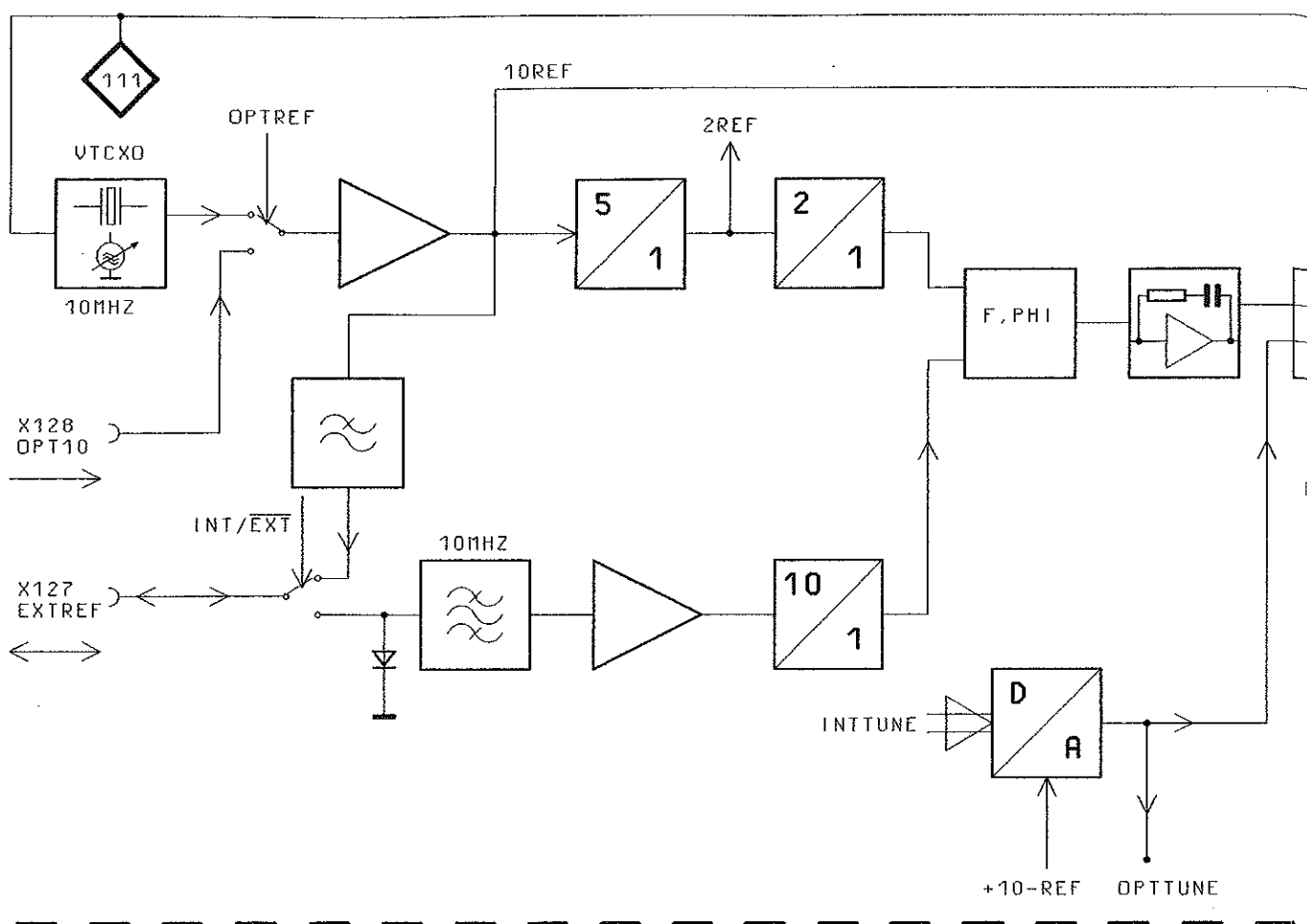

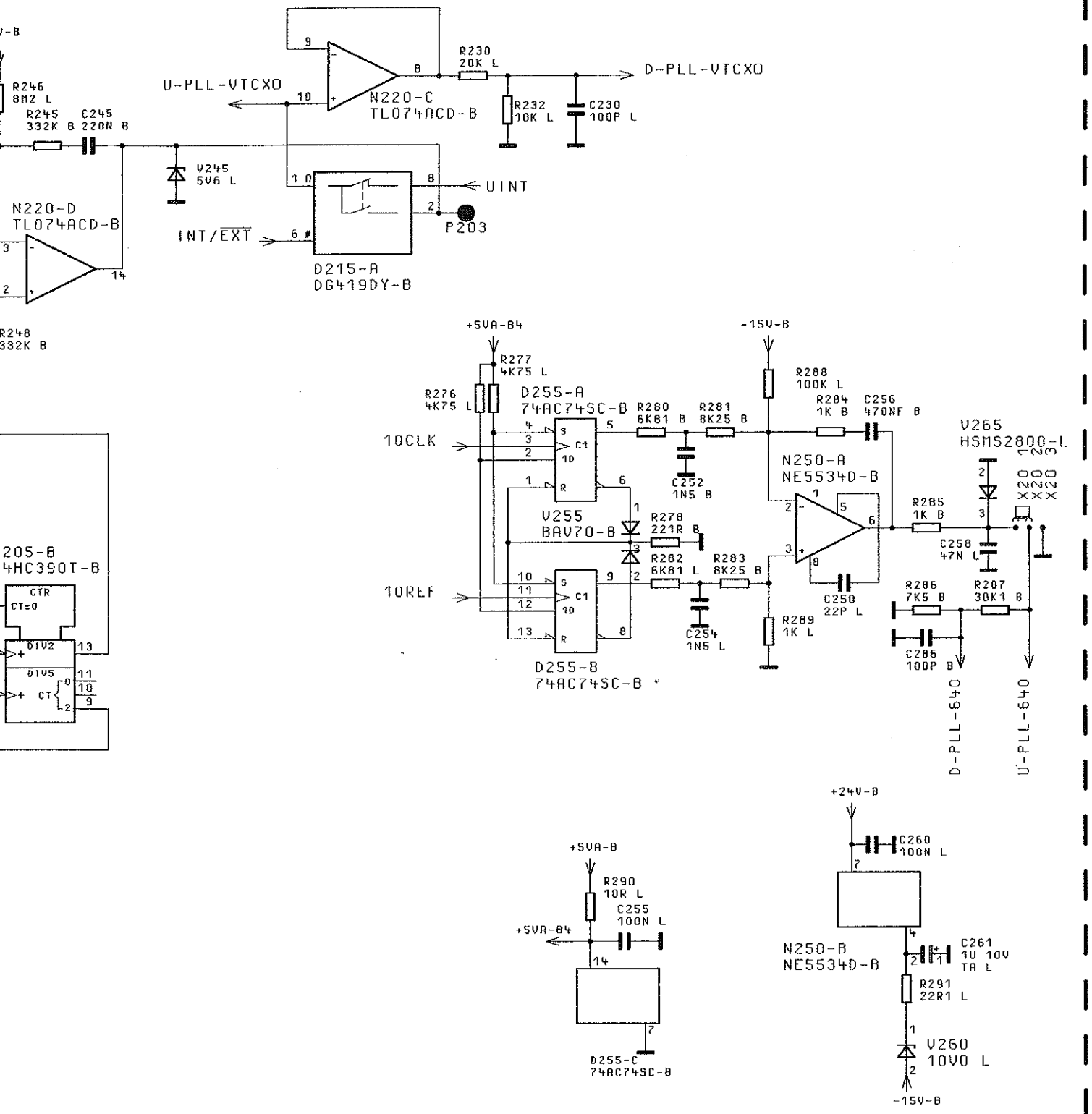

1 2 3 4

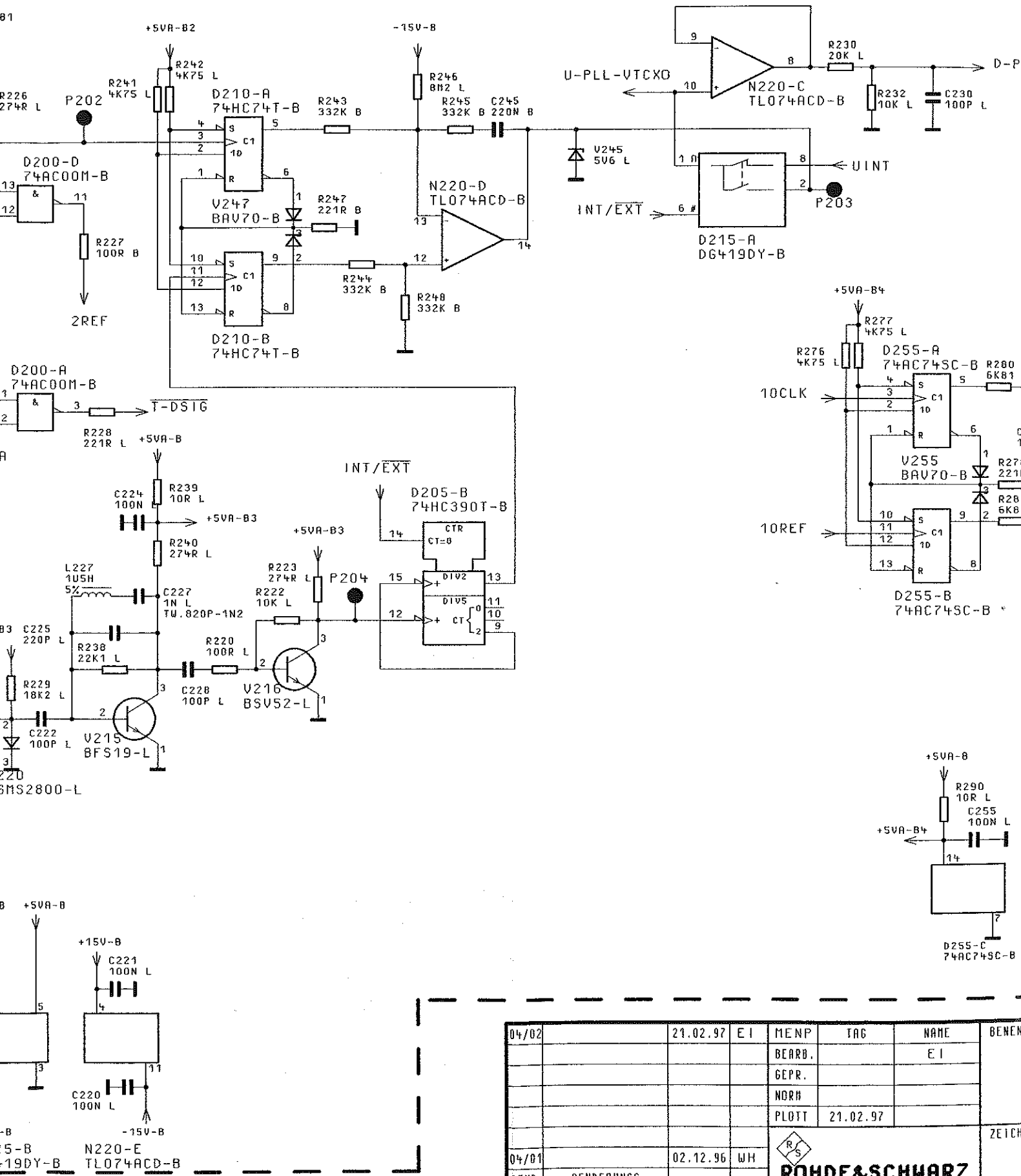

04/02	21.02.97	E I	MENP	TAG	NAME	BENENNUNG	
			BEARB.		E I	SYNTHESIZER	
			GEPR.			SYNTHESIZER	
			NORM				
			PLOTT	21.02.97			
04/01	02.12.96	WH	 ROHDE & SCHWARZ		ZEICHN.-NR.	1062.6409.015	BLATT-NR. 2+
REND. IND.	DATUM	NAME			REG. I. V.	1062.5502	ERSTE Z.
	9			10		11	12

81



04/02	21.02.97	E I	MENP	TAG	NAME	BENEN
			BEARB.		E I	
			GEPR.			
			NDRH			
			PLOTT	21.02.97		
04/01	02.12.96	WH			ZEICHN	
RENDERUNGS- IND.	DATUM	NAME			ZU GERÄT	SMY

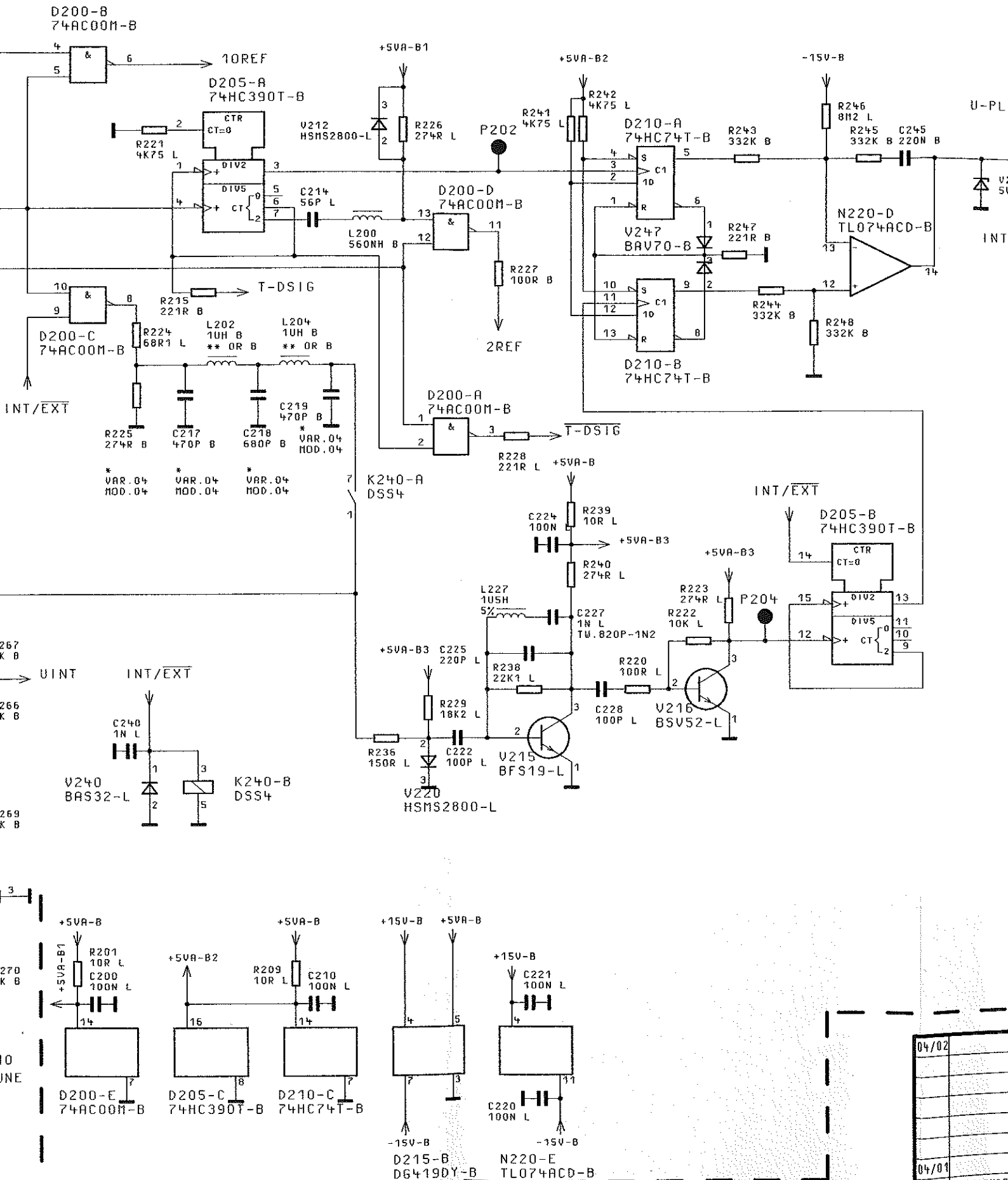

04/02	
04/04	
REND.	RENDE
IND.	HTTE

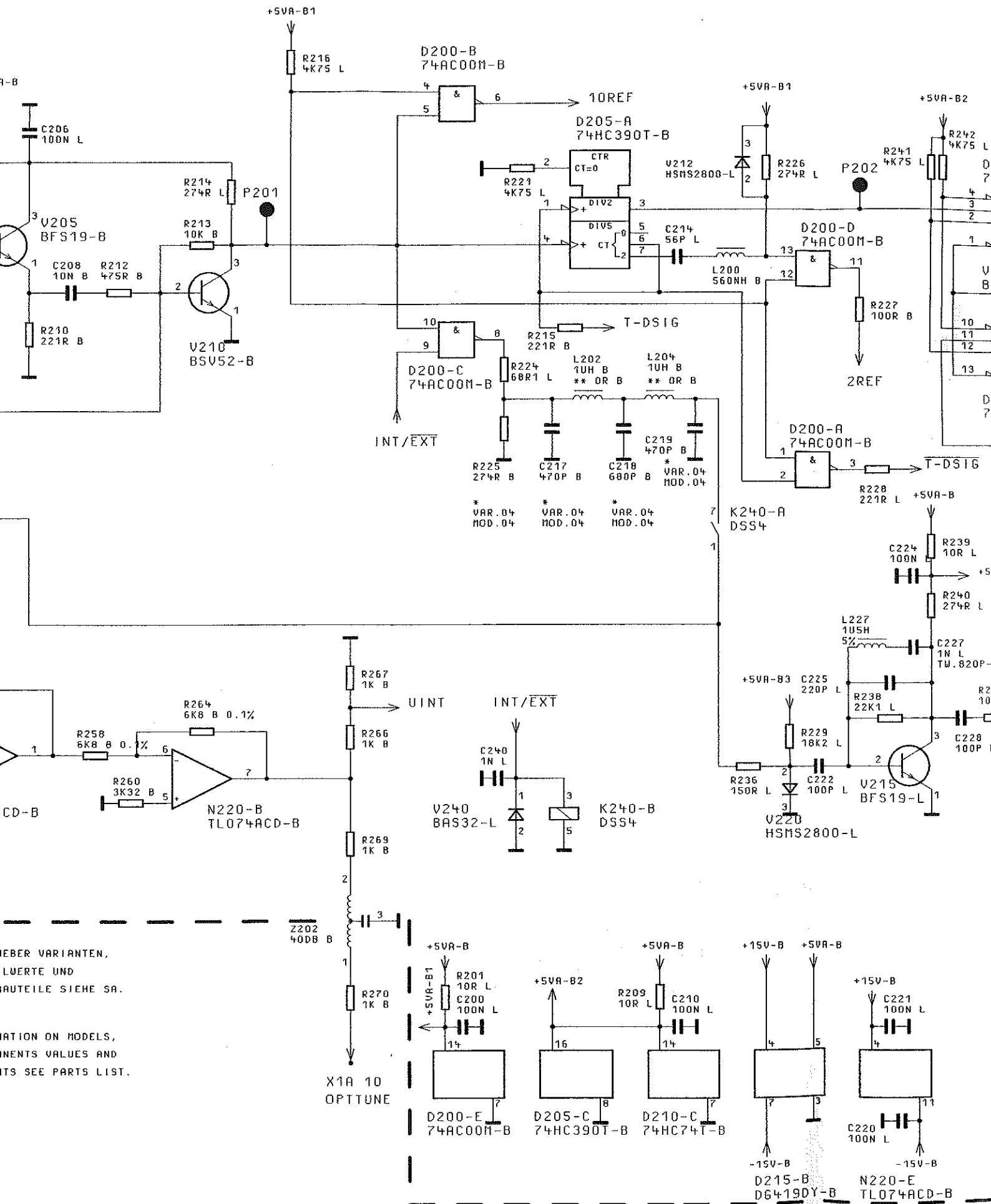

WER VARIANTEN,
WERTE UND
TEILE SIEHE SA.

ON MODELS,
VALUES AND
SEE PARTS LIST.

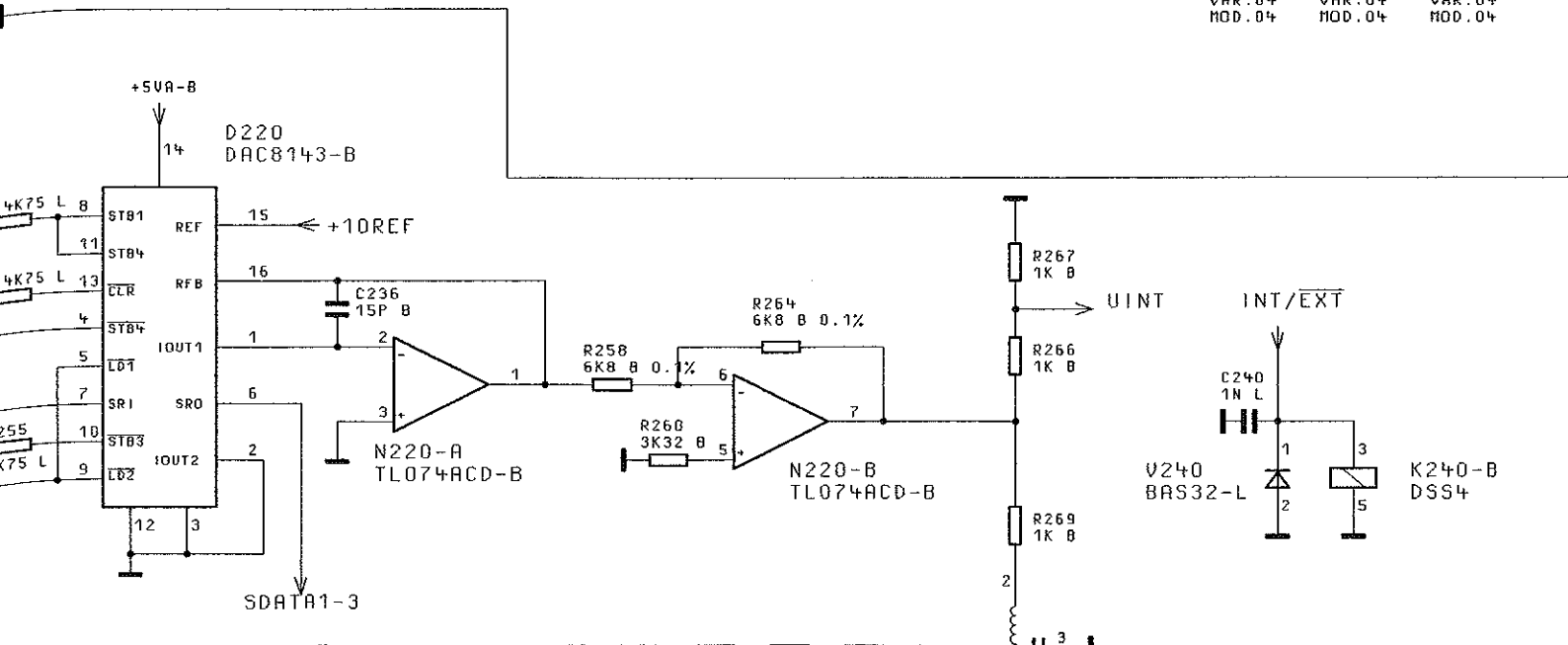
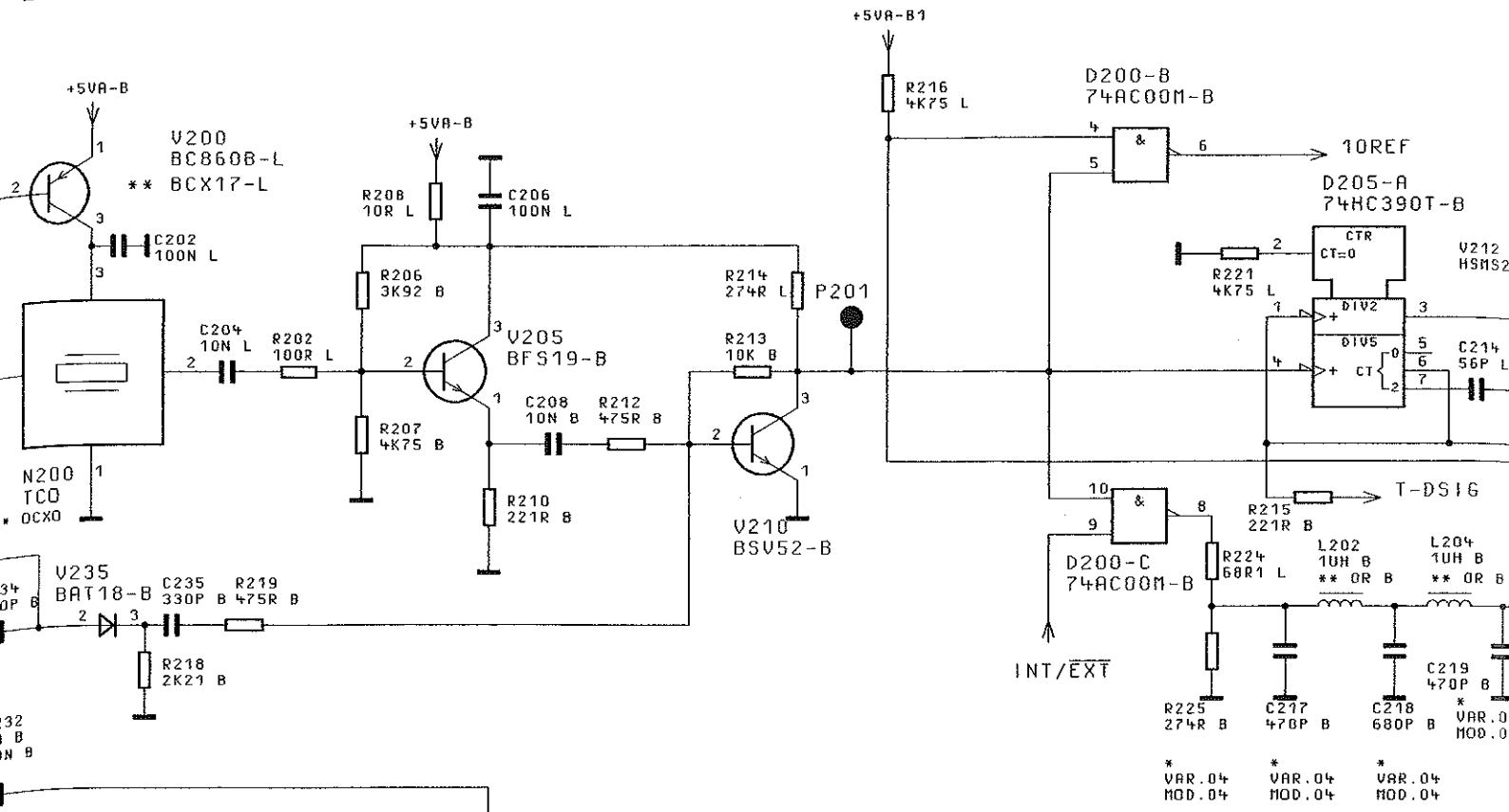

JECKT
 04
 WICHTIG: EGB!
 STATISCH BEFAHRDETE
 BAUTEILE ERFORDERN EINE
 ANDERE HANDHABUNG.
 ATTENTION ESD!
 STATIC SENSITIVE DEVICES
 REQUIRE A SPECIAL HANDLING

BINDENDE ANGABEN UEBER VARIANTEN,
 TRIMMWERTE, BAUTEILWERTE UND
 NICHT BESTUECKTE BAUTEILE SIEHE SA.
 FOR BINDING INFORMATION ON MODELS,
 TRIMMING AND COMPONENTS VALUES AND
 NONFITTED COMPONENTS SEE PARTS LIST.

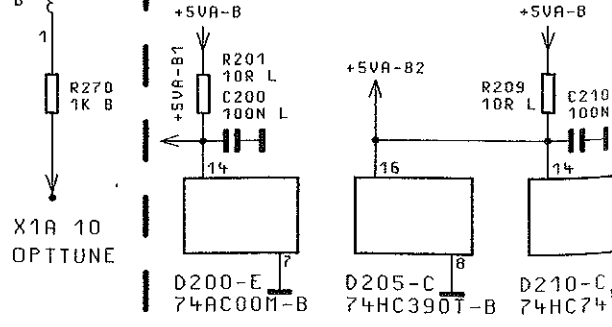

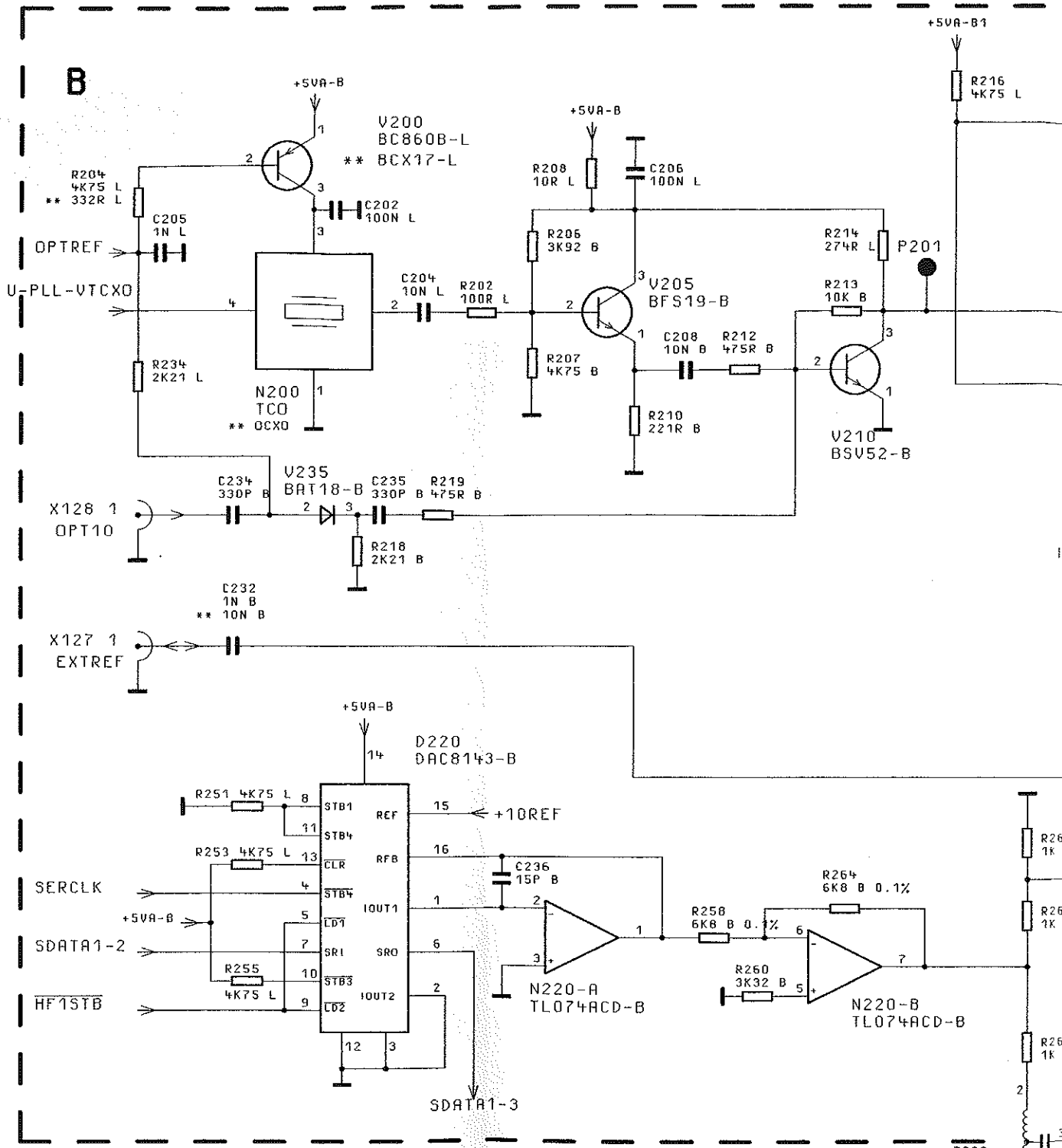

*** NICHT BESTUECKT**
NOT FITTED

**** VAR./MOD. 04**

BINDENDE ANGABEN UEBER VARIANTEN,
TRIMMWERTE, BAUTEILWERTE UND
NICHT-BESTUECKTE BAUTEILE SIEHE SA.

FOR BINDING INFORMATION ON MODELS,
TRIMMING AND COMPONENTS VALUES AND
NONFITTED COMPONENTS SEE PARTS LIST.



ACHTUNG: EGB!
ELEKTROSTATISCH GEFAHRDETE
BAUELEMENTE ERFORDERN EINE
BESONDERE HANDHABUNG.
ATTENTION ESD!
ELECTROSTATIC SENSITIVE DEVICES
REQUIRE A SPECIAL HANDLING

FUER DIESE UNTERLAGE
BEHALTEN WIR UNS ALLE RECHTE VOR

ICHTN.-NR. 1062.6409.01 S

X1A 10
OPTTUN

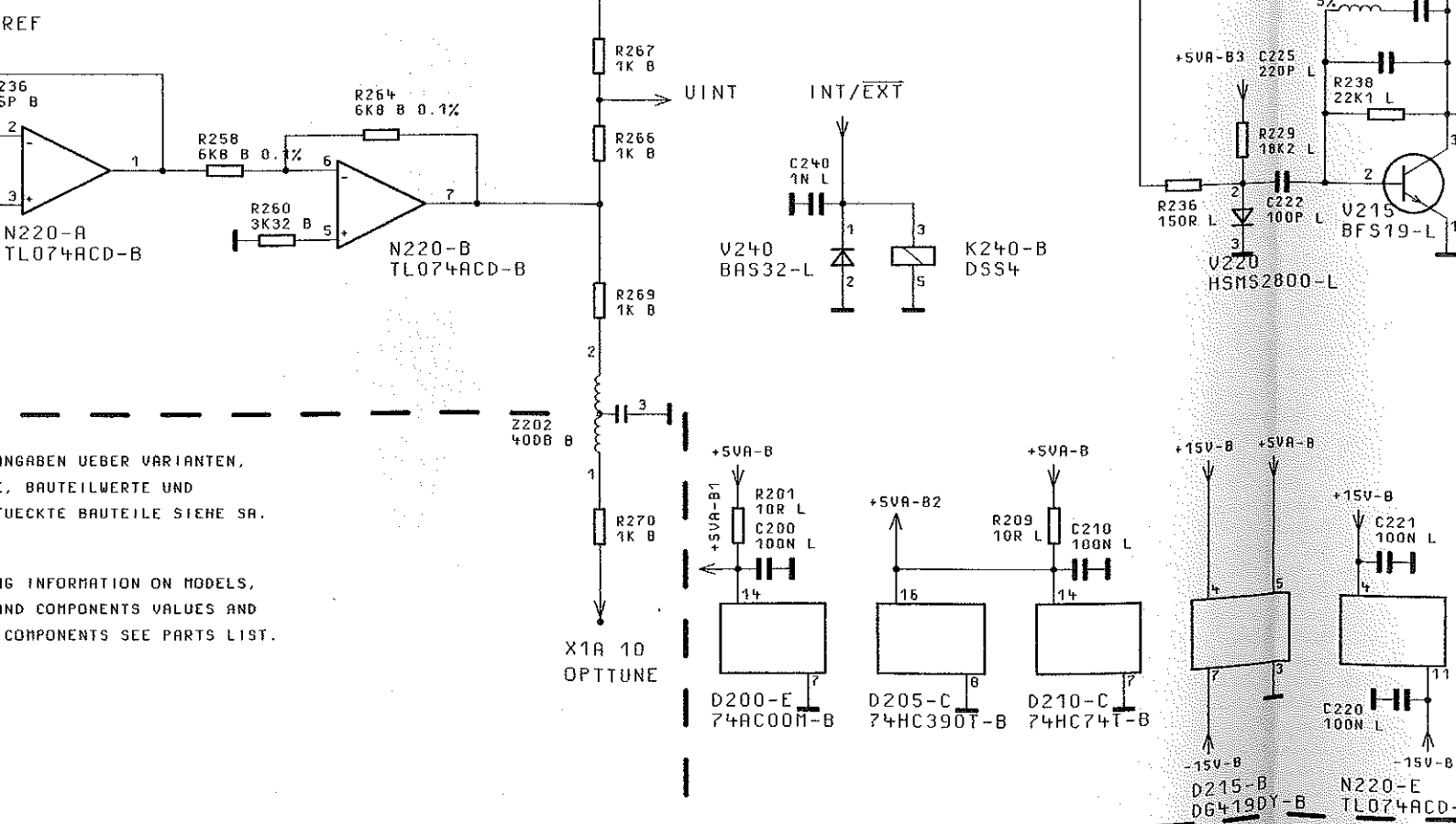
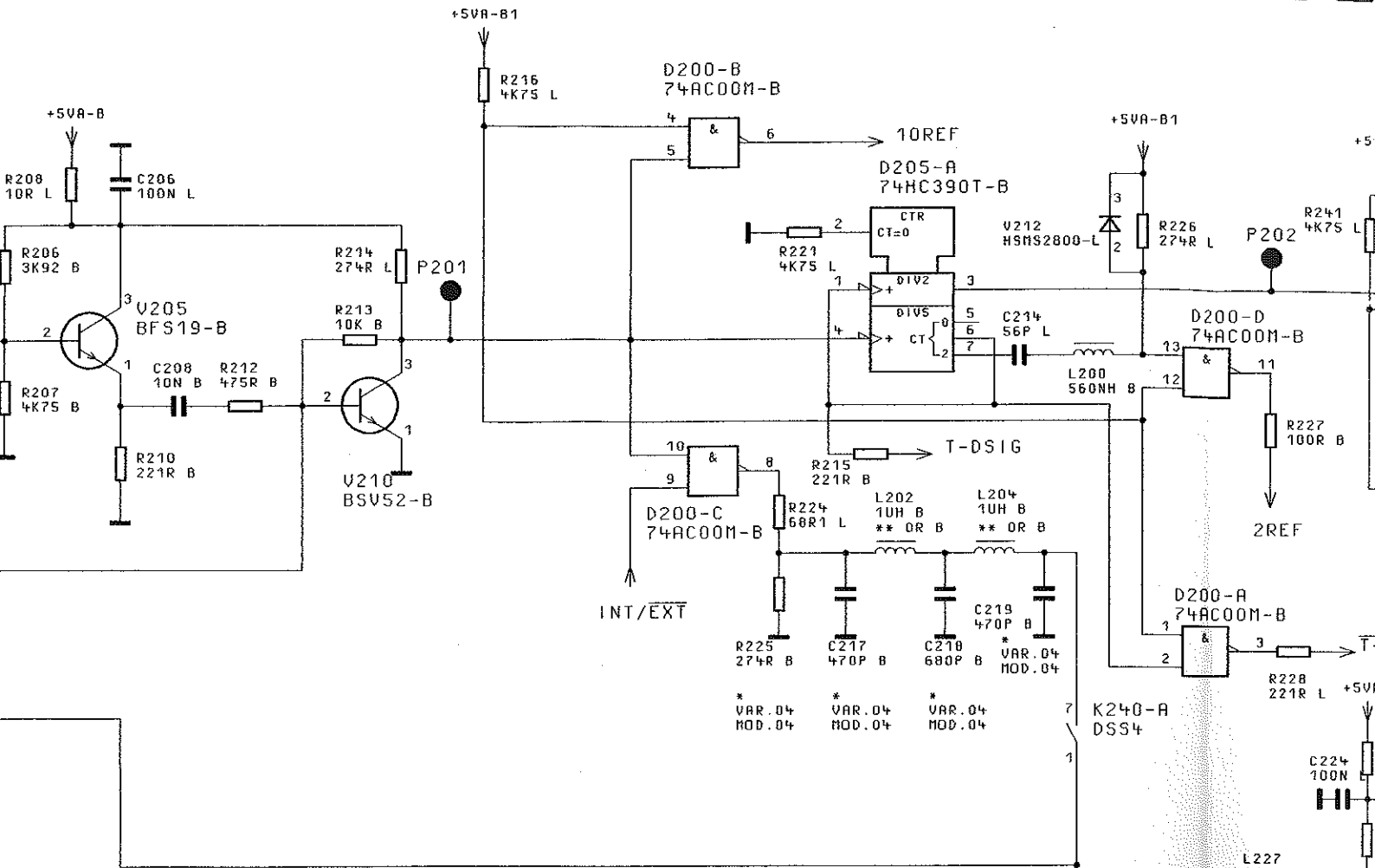

ANGABEN UEBER VARIANTEN,
 BAUTEILWERTE UND
 UEBERTRUCKTE BAUTEILE SIEHE SA.
 INFORMATION ON MODELS,
 COMPONENTS VALUES AND
 COMPONENTS SEE PARTS LIST.

P354

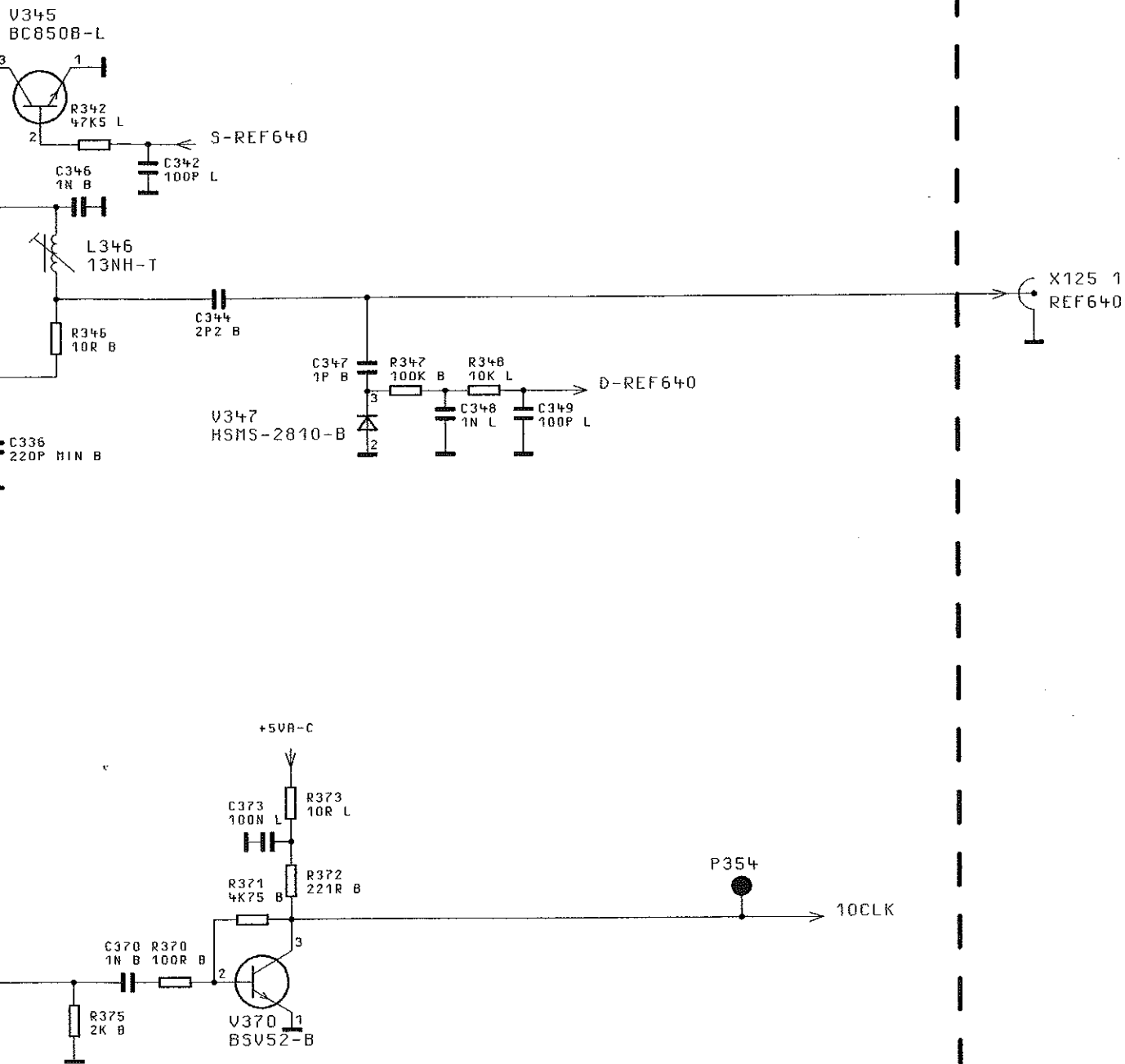

04/02	21.02.97	E I	MENP	TAG	NAME	BENENNUNG SYNTHESIZER SYNTHESIZER	BLATT-NR. 3+ v. 16 BL.		
			BEARB.		E I				
			GEPR.						
			NDRH						
			PLOTT	21.02.97					
04/01	02.12.96	WH	 ROHDE & SCHWARZ			ZEICHN.-NR.	1062.6409.015		
REND. IND.	ÄNDERUNGS-MITTEILUNG	DATUM				NAME		ZU GERÄT	SMY
9			10			11		12	

NETE
INE
VICES
ING

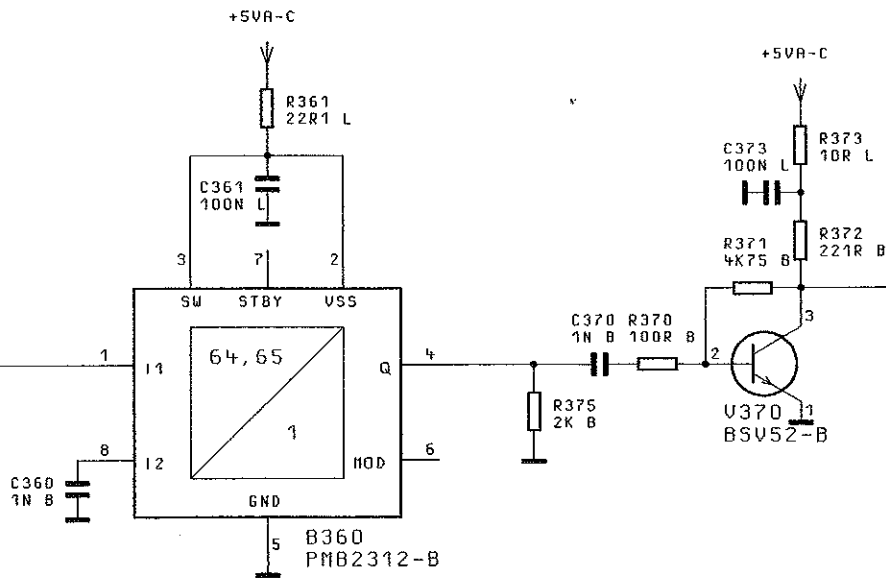
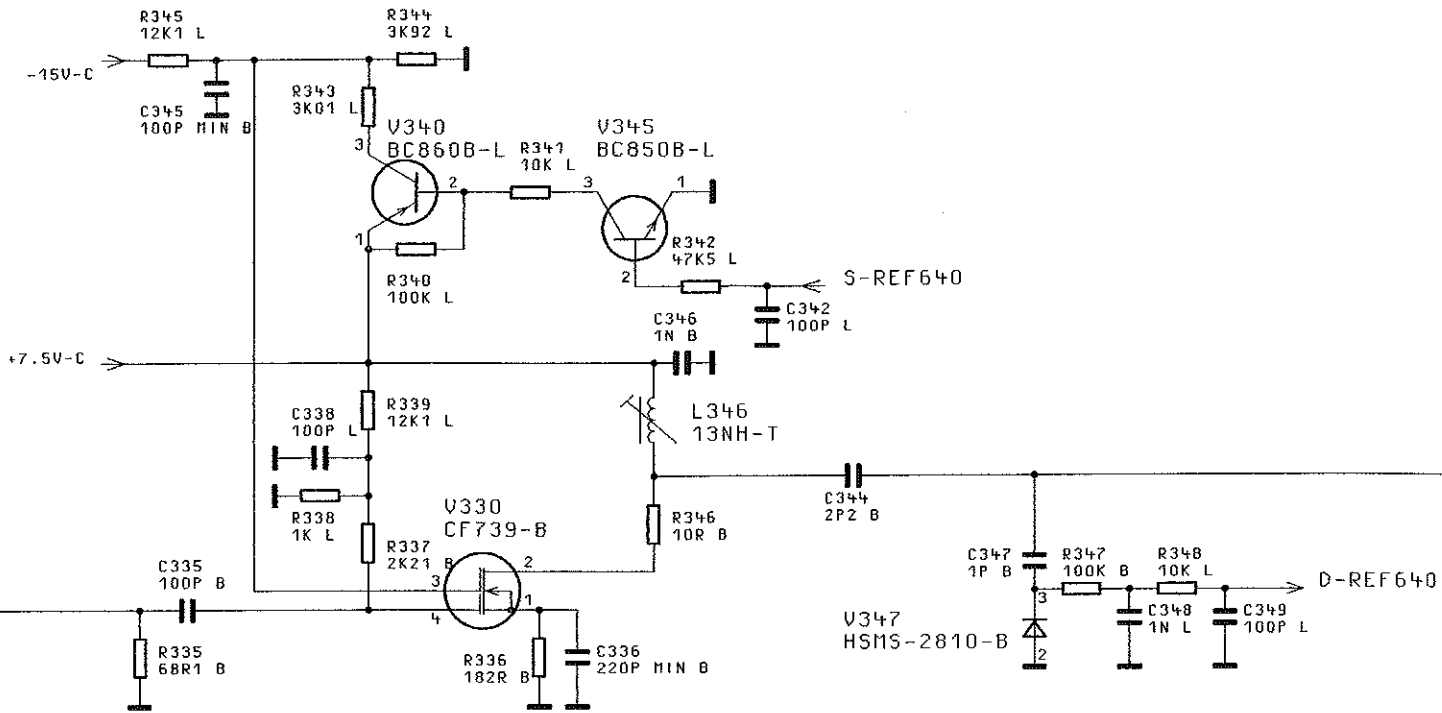

STUECKT

ANDERER VARIANTEN,
WERTE UND
TEILE SIEHE SA.
ON MODELS.
VALUES AND
SEE PARTS LIST.

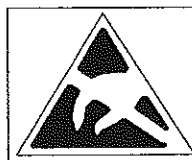

ACHTUNG: EGB!
ELEKTROSTATISCH GEFÄHRDETE
BAUELEMENTE ERFORDERN EINE
BESONDERE HANDHABUNG.
ATTENTION ESD!
ELECTROSTATIC SENSITIVE DEVICES
REQUIRE A SPECIAL HANDLING

04/02	21.02.97	E I	MENP	TAG	NAME
			BEARB.		E I
			GEPR.		
			NORM		
			PLOTT	21.02.97	
04/01	02.12.96	W H	 ROHDE & SCHWARZ		
REND. IND.	RENDERUNGS- MITTEILUNG	DATUM			

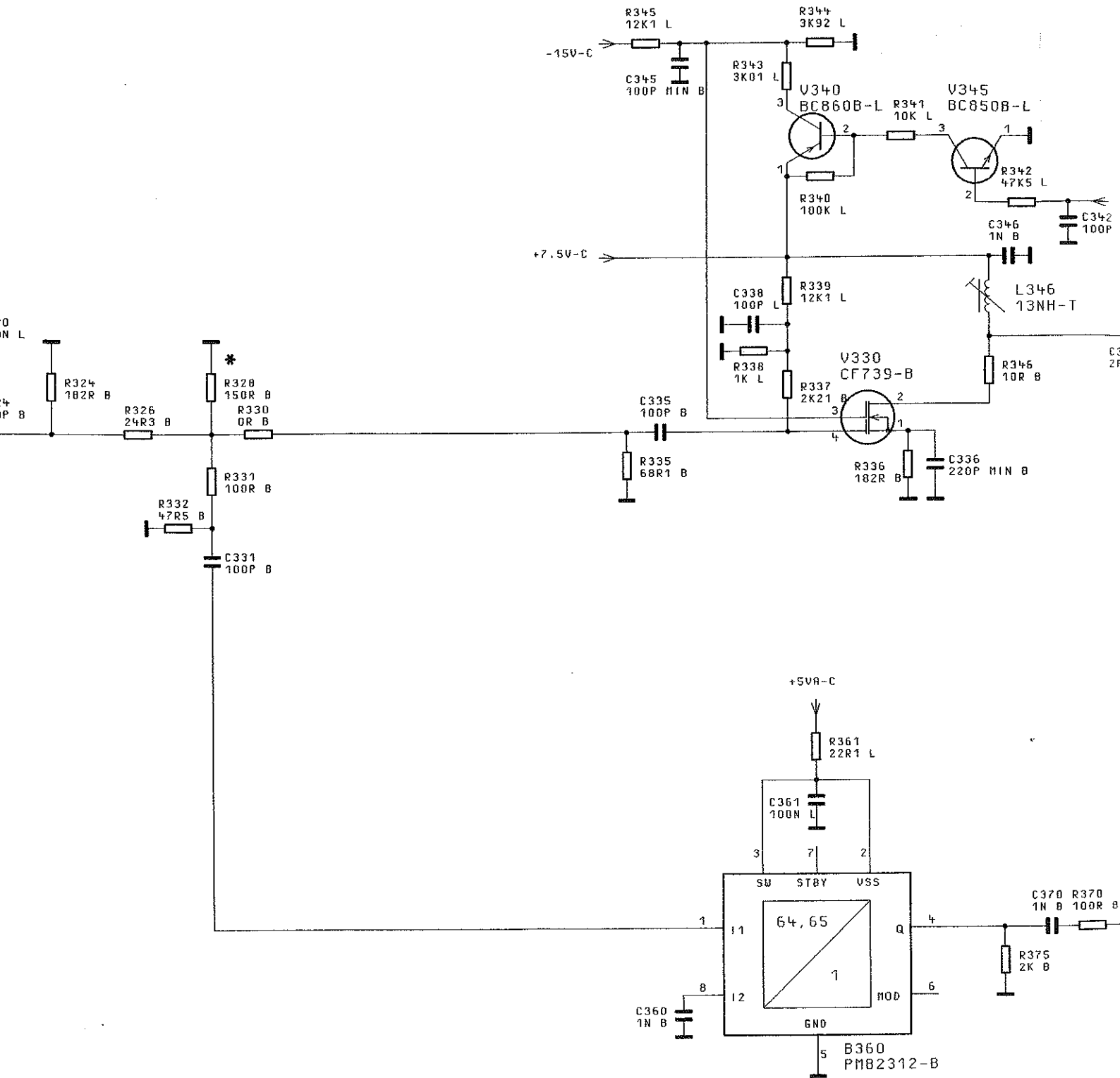

* NICHT BESTUECKT
NOT FITTED

BINDENDE ANGABEN UEBER VARIANTEN,
TRIMMWERTE, BAUTEILWERTE UND
NICHT BESTUECKTE BAUTEILE SIEHE SA.
FOR BINDING INFORMATION ON MODELS,
TRIMMING AND COMPONENTS VALUES AND
NONFITTED COMPONENTS SEE PARTS LIST.

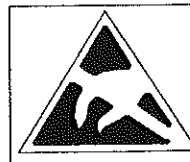

ACHTUNG: EGB!
ELEKTROSTATISCH GEFAEHRDETE
BAUELEMENTE ERFOEDERN EINE
BESONDERE HANDHABUNG.
ATTENTION: ESD!
ELECTROSTATIC SENSITIVE DEVICES
REQUIRE A SPECIAL HANDLING

04/02	
04/01	
REND.	REND.
IND.	HITT

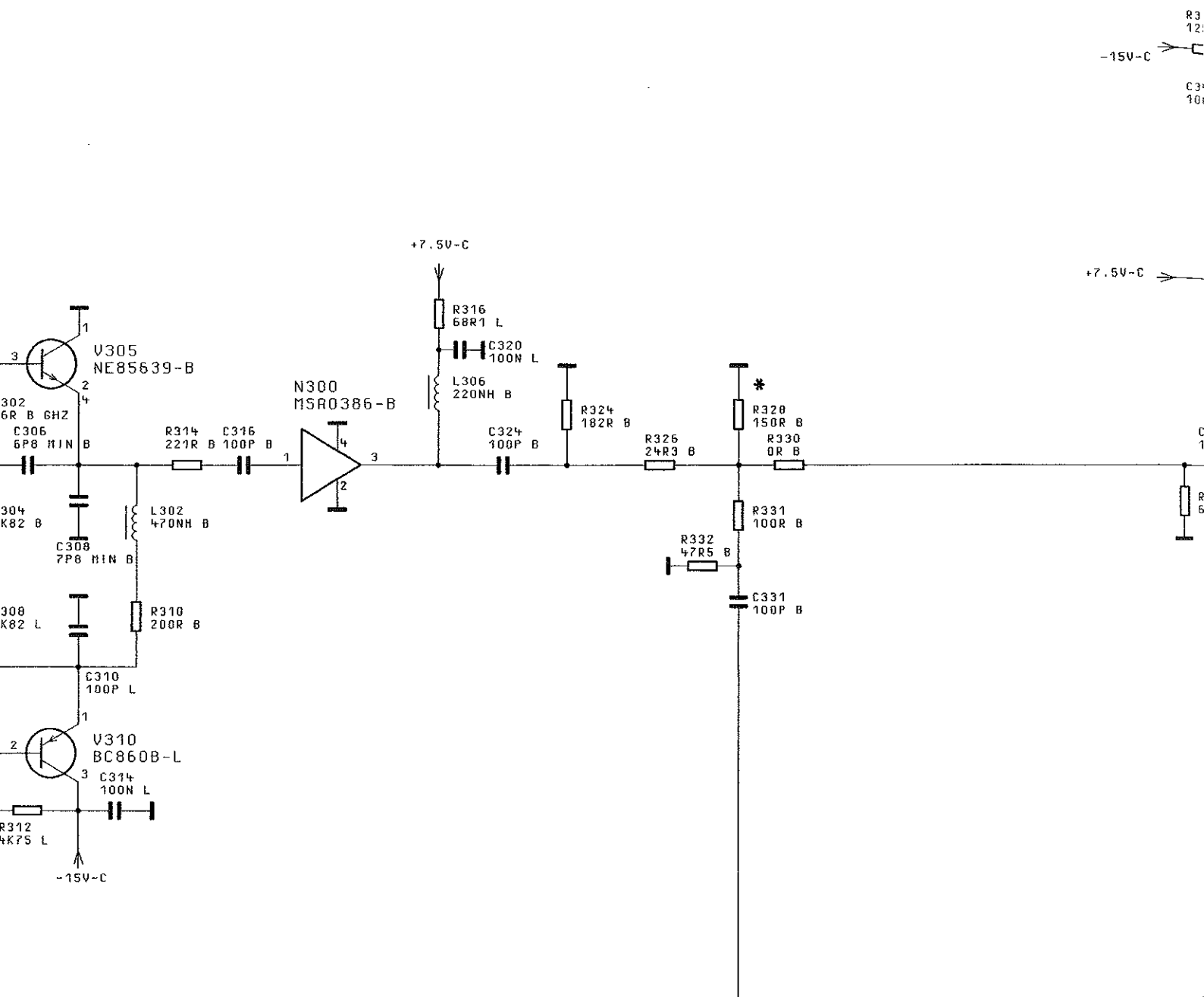

*** NICHT BESTUECKT**
 NOT FITTED

BINDENDE ANGABEN UEBER VARIANTEN,
 TRIMMWERTE, BAUTEILWERTE UND
 NICHT BESTUECKTE BAUTEILE. SIEHE SA.
 FOR BINDING INFORMATION ON MODELS,
 TRIMMING AND COMPONENTS VALUES AND
 NONFITTED COMPONENTS SEE PARTS LIST.

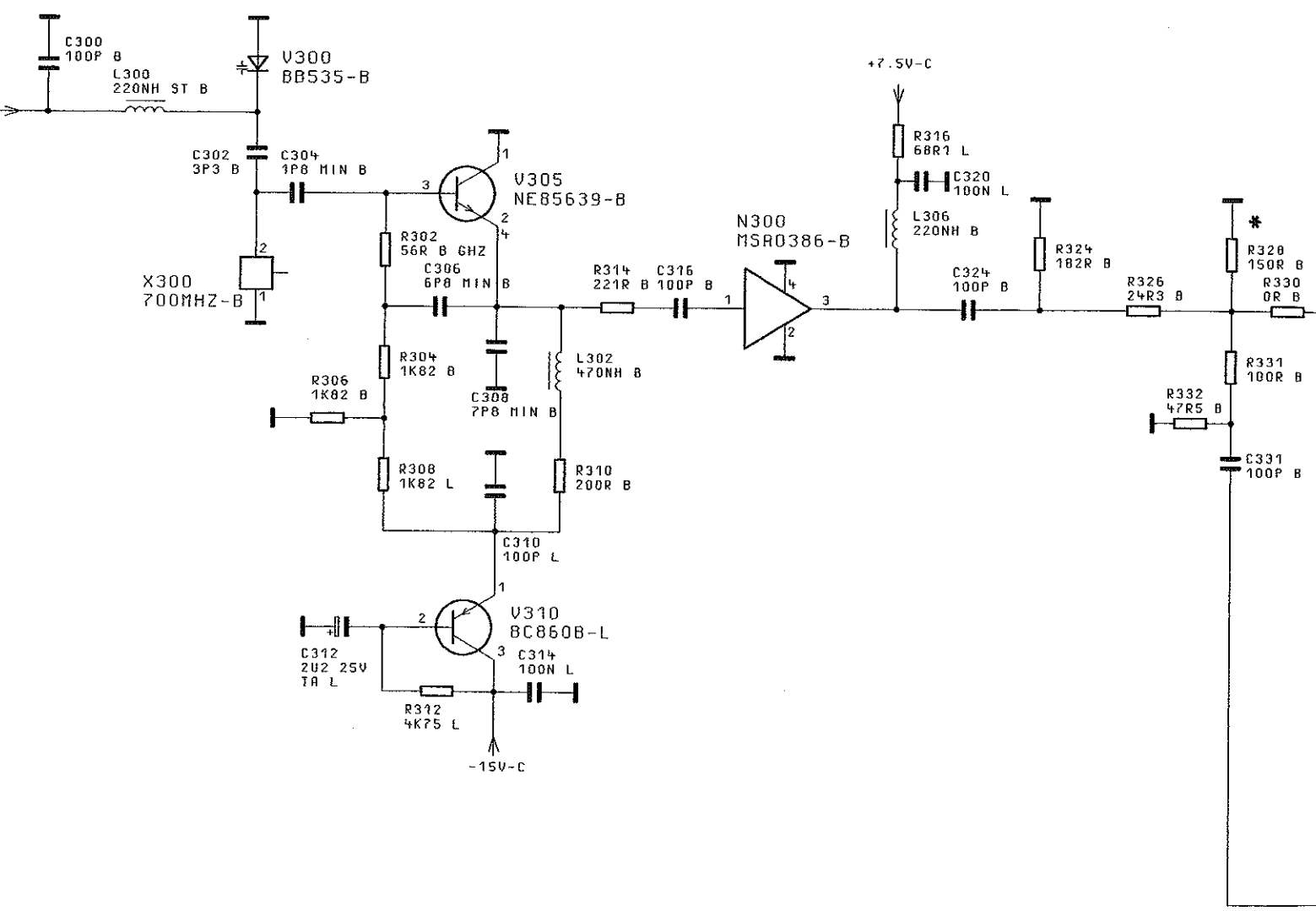

*
 BIN
 TRI
 NIC
 FOR
 TRI
 NON

C

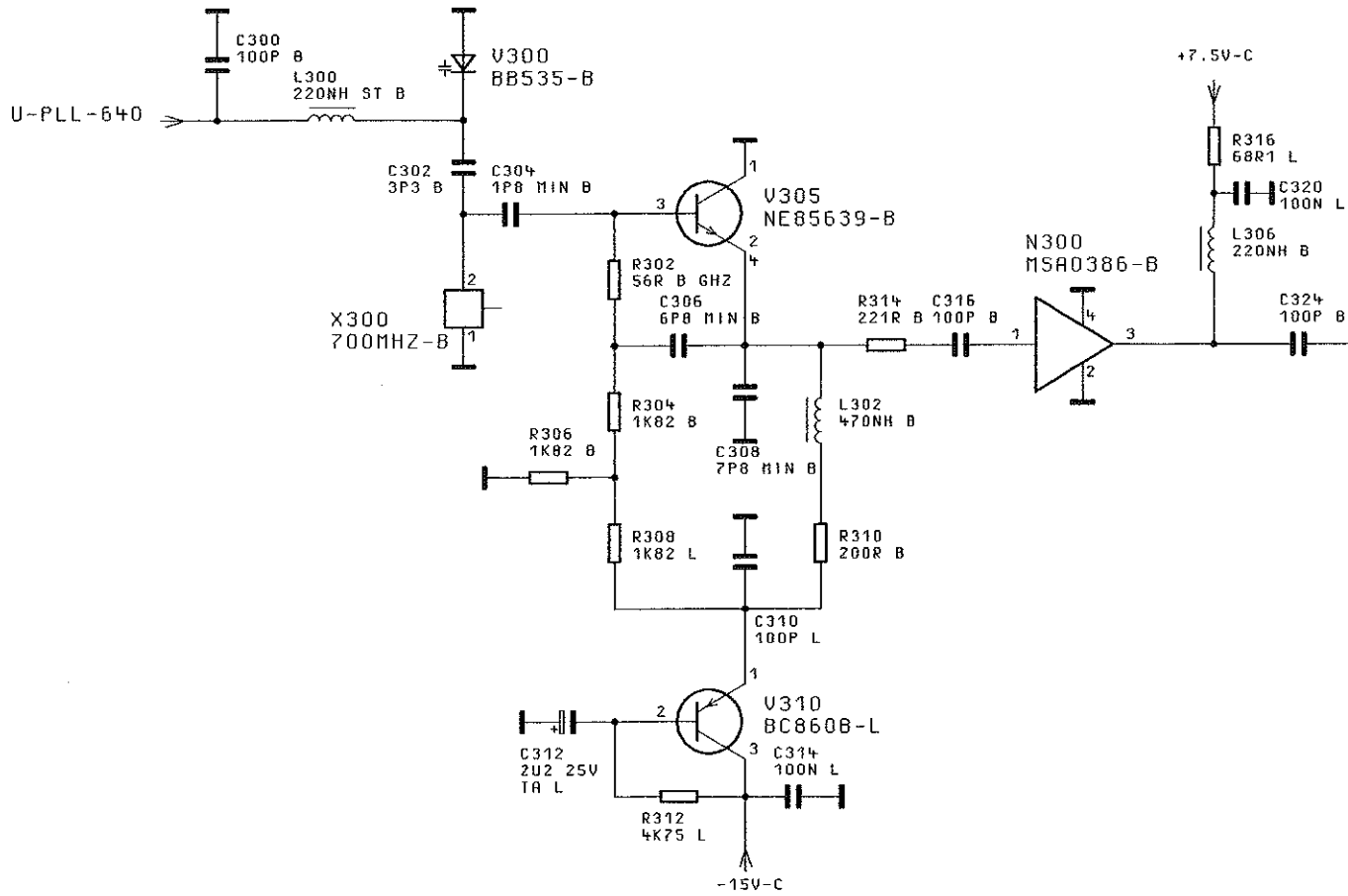

FUER DIESE UNTERLAGE
BEHALTEN WIR UNS ALLE RECHTE VOR

ZEICHN.-NR. 1062.6409.01 S

1 2 3 4

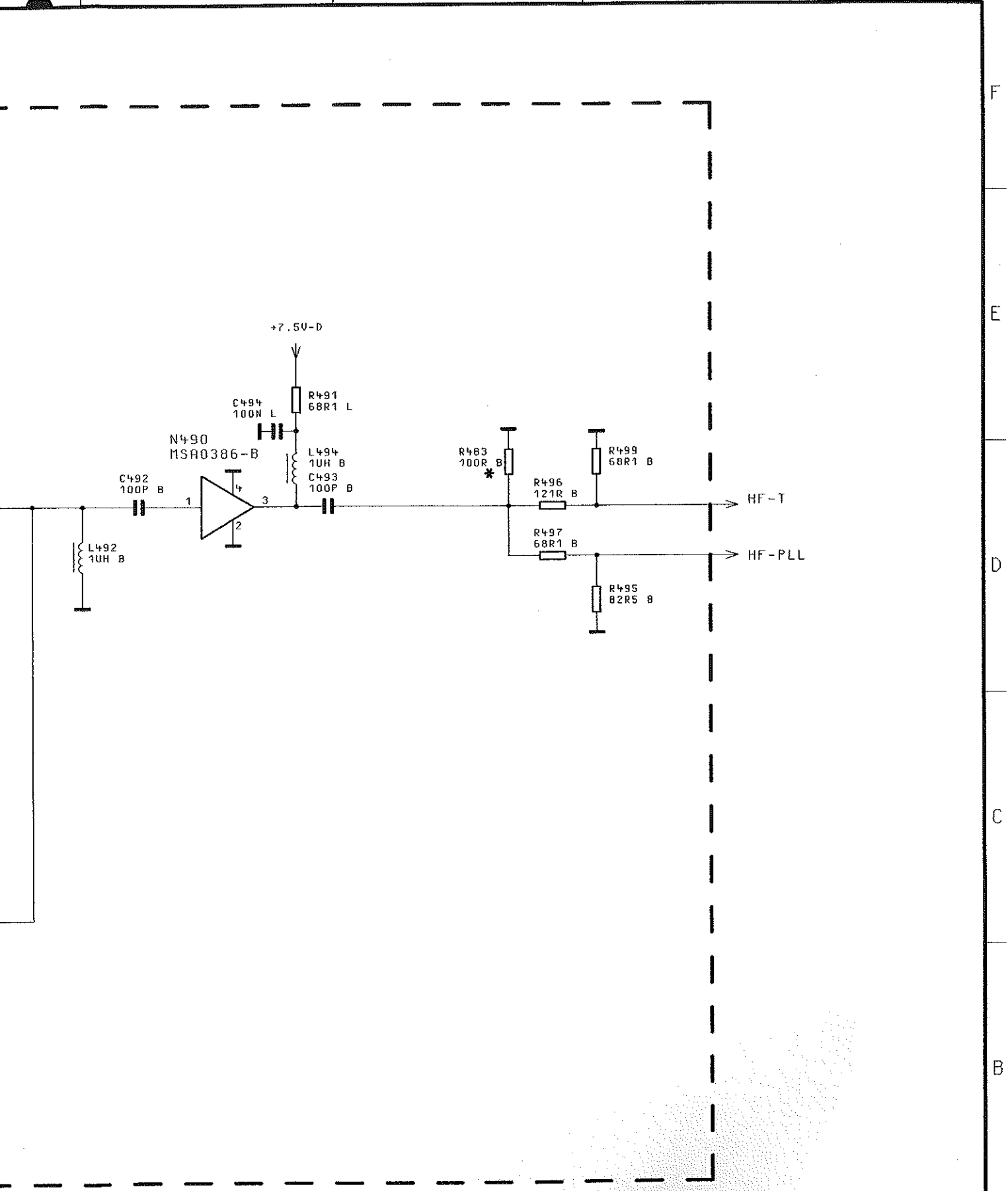

04/02		21.02.97	E I	MENP	TAG	NAME	BENENNUNG		
				BEARB.		E I	SYNTHESIZER SYNTHESIZER		
				GEPR.					
				NORN					
				PLOTT	21.02.97				
04/01		02.12.96	WH	 ROHDE & SCHWARZ			ZEICHN.-NR.	BLATT-NR.	
REND. IND.	RENDERUNGS- MITTEILUNG	DATUM	NAME				1062.6409.01S	4+	
				ZU GERÄT	SMY	REG. I. V.	1062.5502	ERSTE Z.	1062.5502

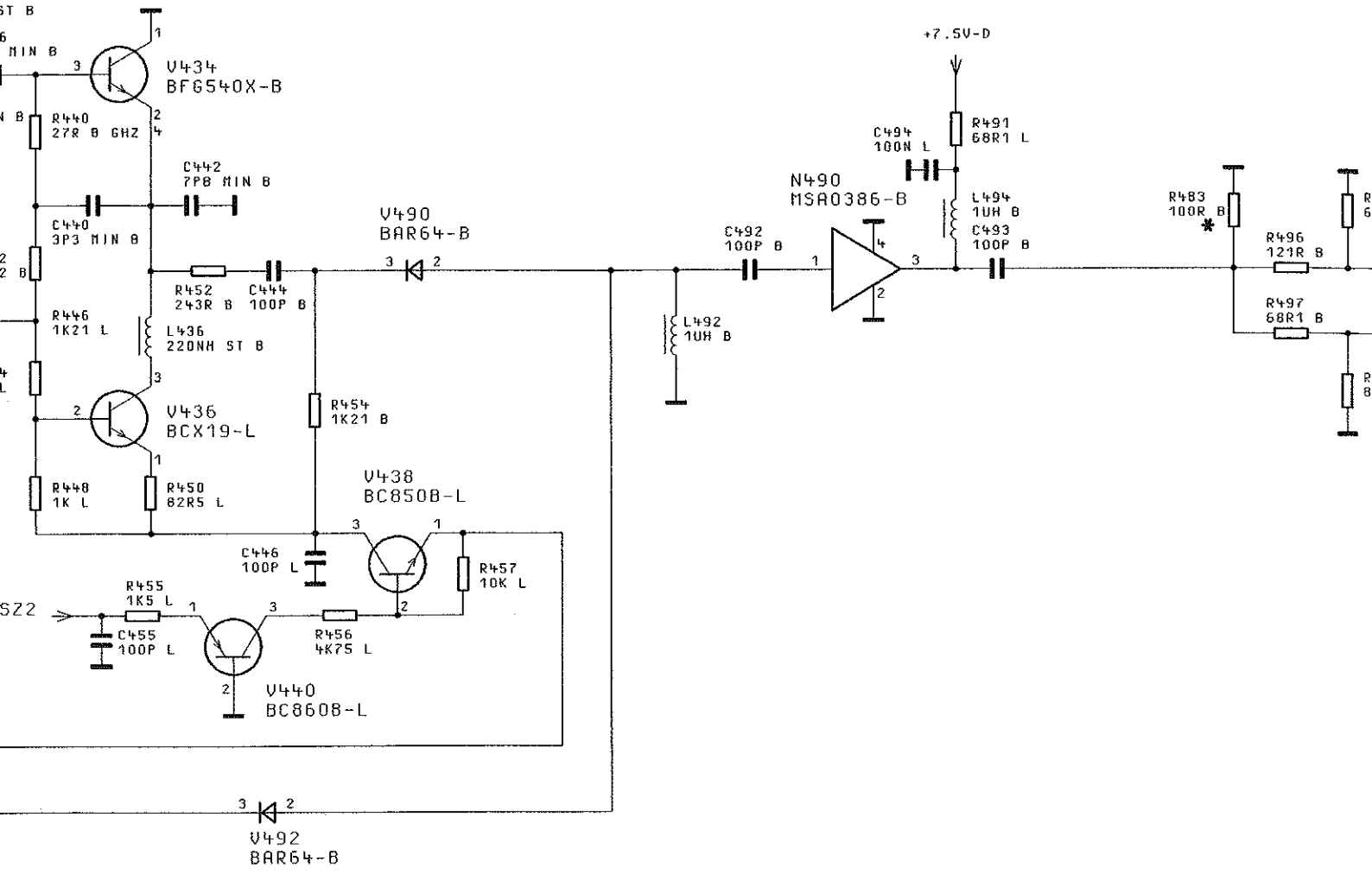

*** NICHT BESTUECKT**

NOT FITTED

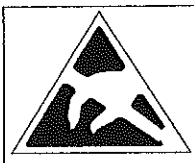

ACHTUNG: EGB!
 ELEKTROSTATISCH GEFÄHRDETE
 BAUELEMENTE ERFORDERN EINE
 BESONDERE HANDHABUNG.
ATTENTION ESD!
 ELECTROSTATIC SENSITIVE DEVICES
 REQUIRE A SPECIAL HANDLING

04/02		21.02.97	E I	MENP	TAG	NAME	BENENNUNG
				BEARB.		E I	SY
				GEPR.			SYN
				NDRN			
				PLOTT	21.02.97		
04/04		02.12.96	WH				ZEICHN.-
REND. IND.	RENDERUNGS- MITTEILUNG	DATUM	NAME				ZU GERÄT

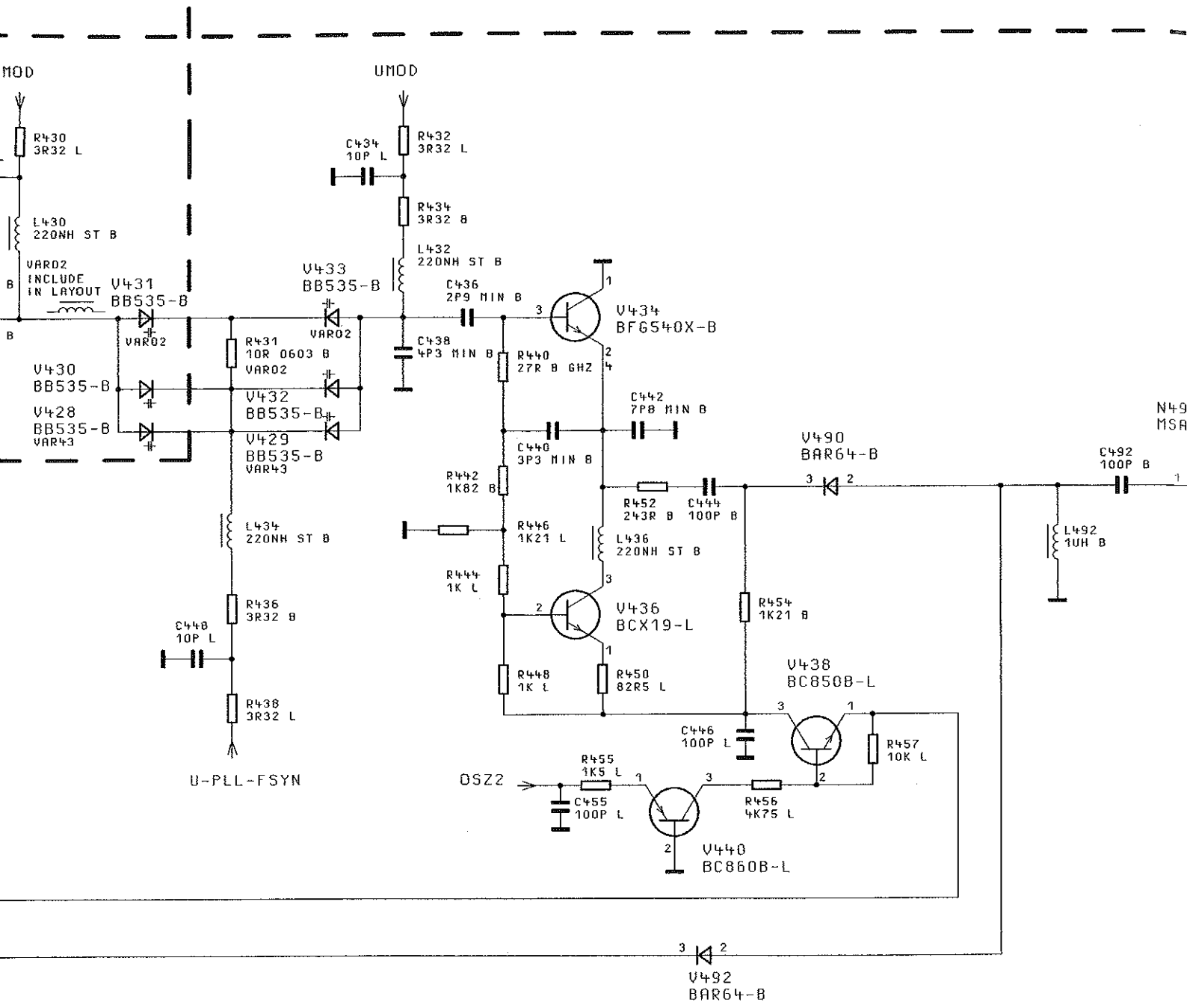

* NICHT BESTUECKT

NOT FITTED

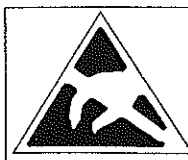

ACHTUNG: EGB!
ELEKTROSTATISCH GEFÄHRDETE
BAUELEMENTE ERFORDERN EINE
BESONDERE HANDHABUNG.
ATTENTION ESD!
ELECTROSTATIC SENSITIVE DEVICES
REQUIRE A SPECIAL HANDLING

BINDENDE ANGABEN UEBER VARIANTEN,
TRIMMWERTE, BAUTEILWERTE UND
NICHT BESTUECKTE BAUTEILE SIEHE SA.
FOR BINDING INFORMATION ON MODELS,
TRIMMING AND COMPONENTS VALUES AND
NONFITTED COMPONENTS SEE PARTS LIST.

04/02	
04/01	
REND. IND.	ÄNDERUNGS MITTEILUNG

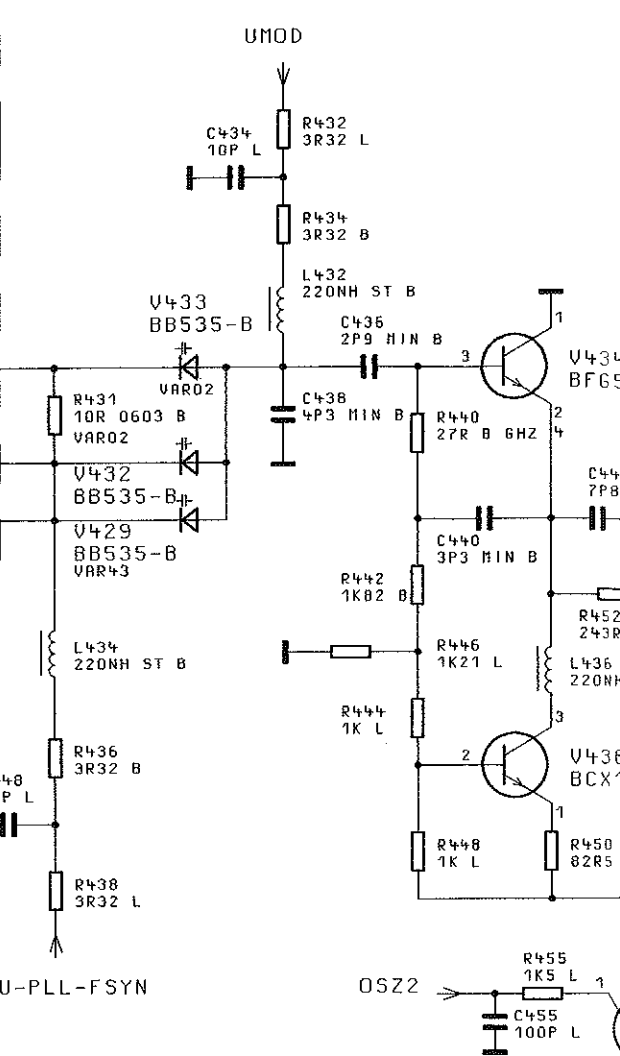
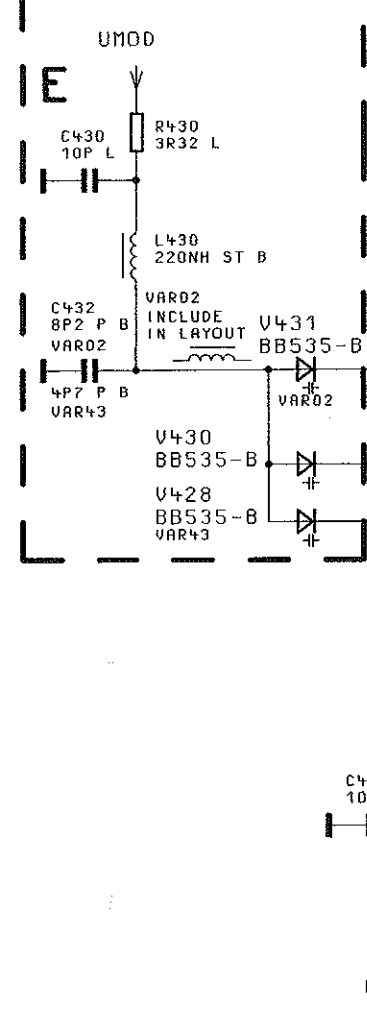
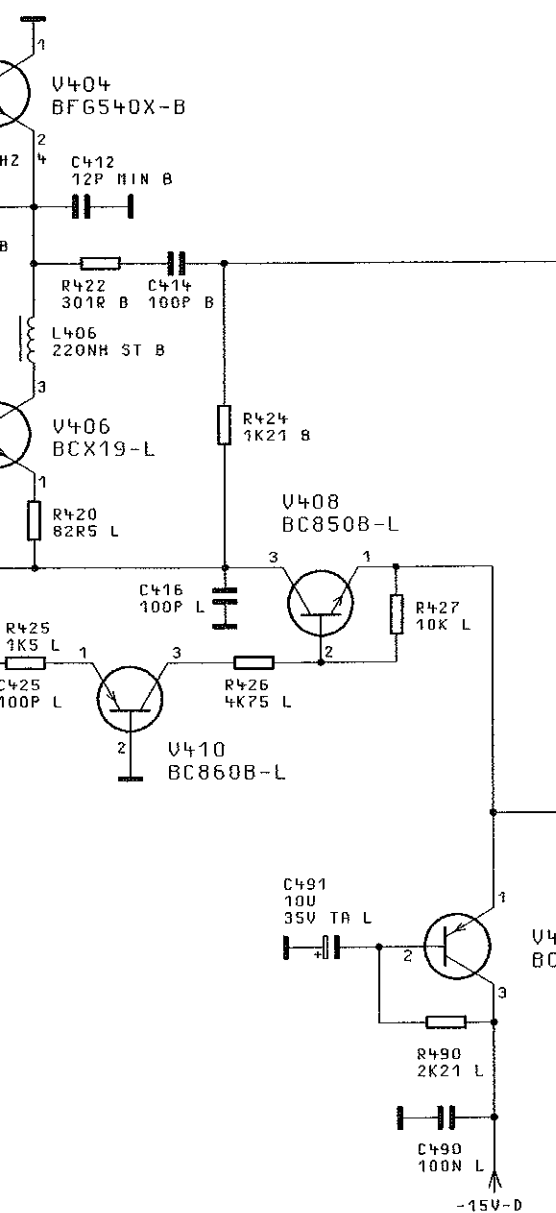

U-PLL-FSYN

OSZ2

* N
NO

BINDENDE ANGABEN UEBER VARIANTEN,
TRIMMWERTE, BAUTEILWERTE UND
NICHT BESTUECKTE BAUTEILE SIEHE SR.
FOR BINDING INFORMATION ON MODELS,
TRIMMING AND COMPONENTS VALUES AND
NONFITTED COMPONENTS SEE PARTS LIST.



00
32 L

00
ONH ST B

CLUDE
LAYOUT

D UMOD

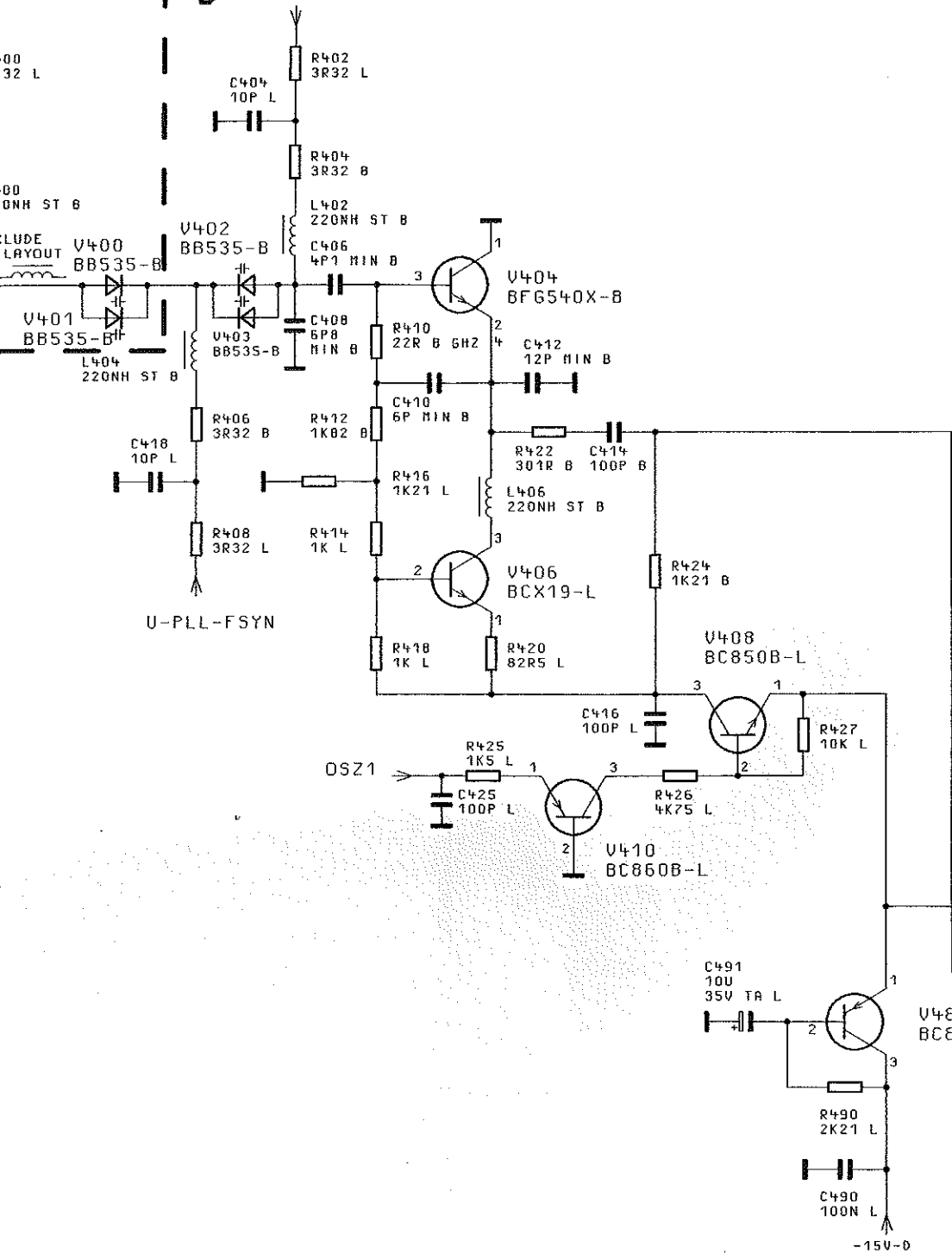

E UMOD

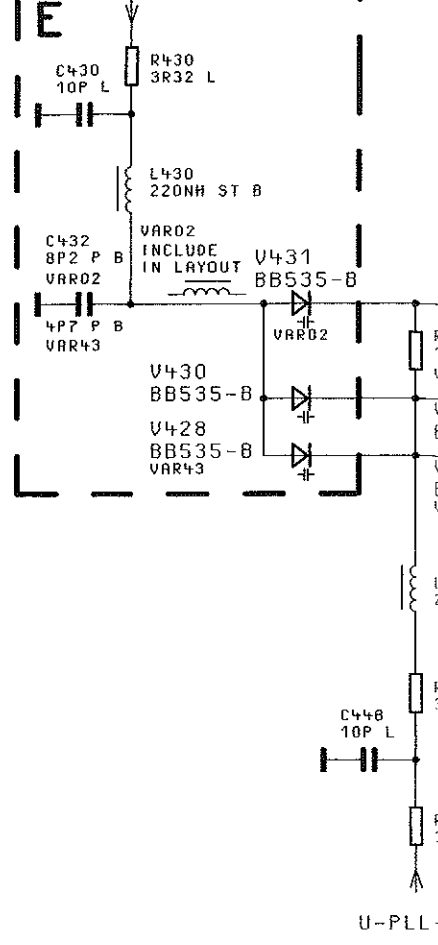

BINDENDE
TRIMMWERTE
NICHT BES
FOR BINDI
TRIMMING
NONFITTED

BEHALTEN WIR UNS ALLE RECHTE VOR

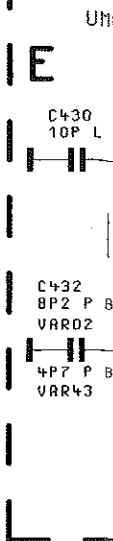
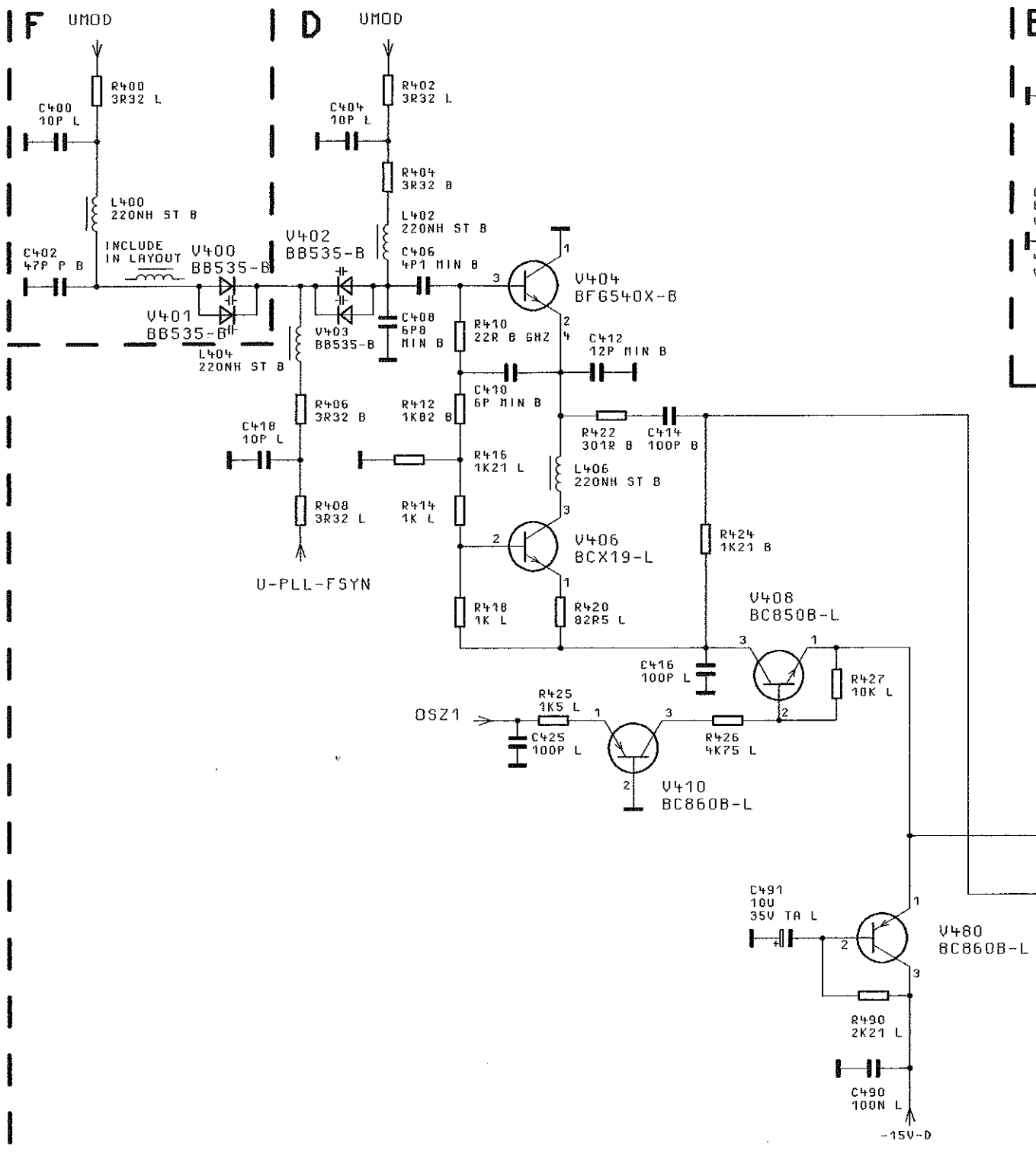

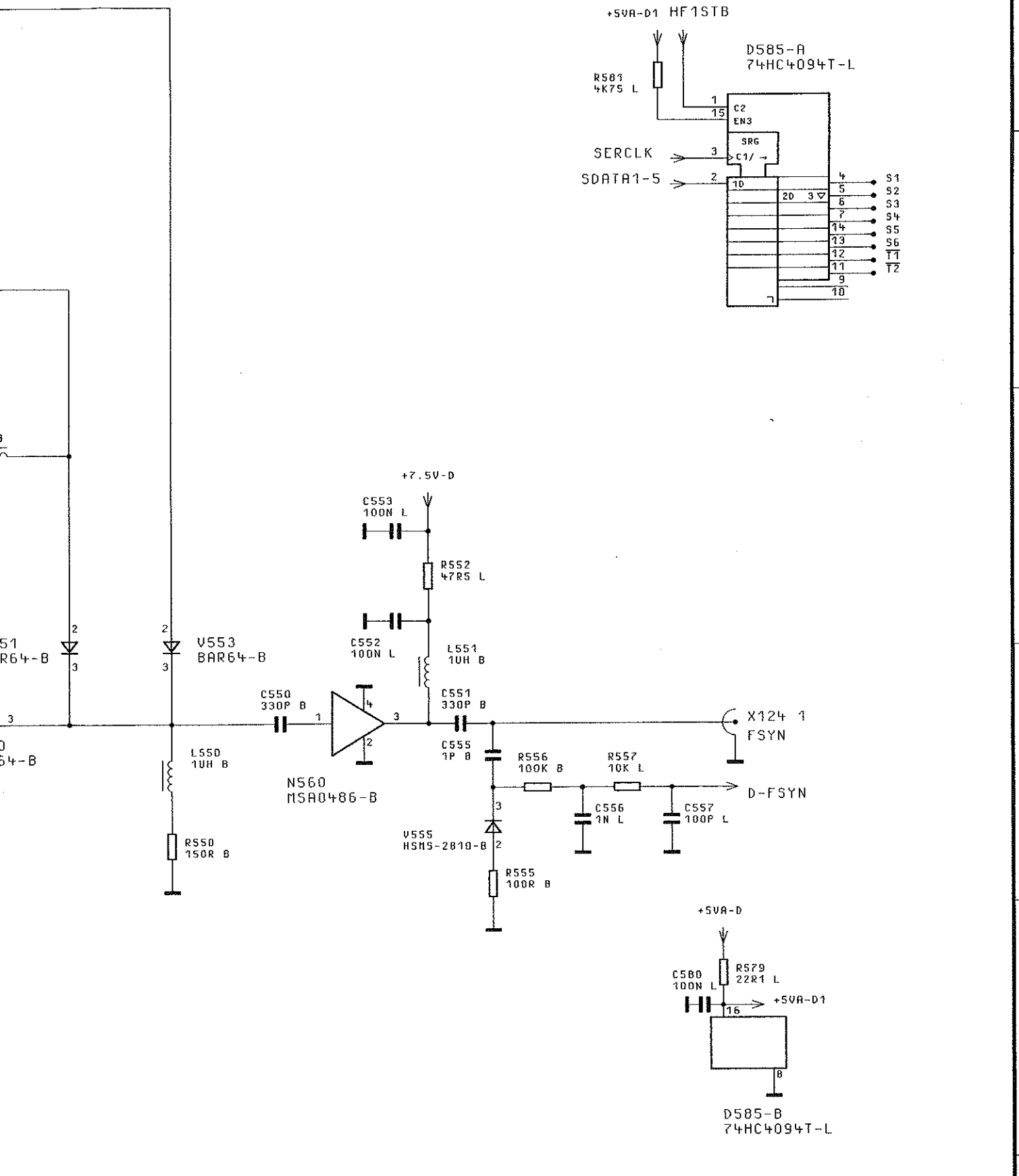

04/02	21.02.97	E I	MENP	TAG	NAME	BENENNUNG	
			BEARB.		E I	SYNTHESIZER SYNTHESIZER	
			GEPR.				
			NORM				
			PLOTT	21.02.97			
04/01	02.12.96	WH	 ROHDE & SCHWARZ			ZEICHN.-NR.	BLATT-NR.
REND. IND.	ÄNDERUNGS- MITTEILUNG	DATUM				NAME	1062.6409.015
ZU GERÄT			SMY	REG. I. V.	1062.5502	ERSTE Z.	1062.5502

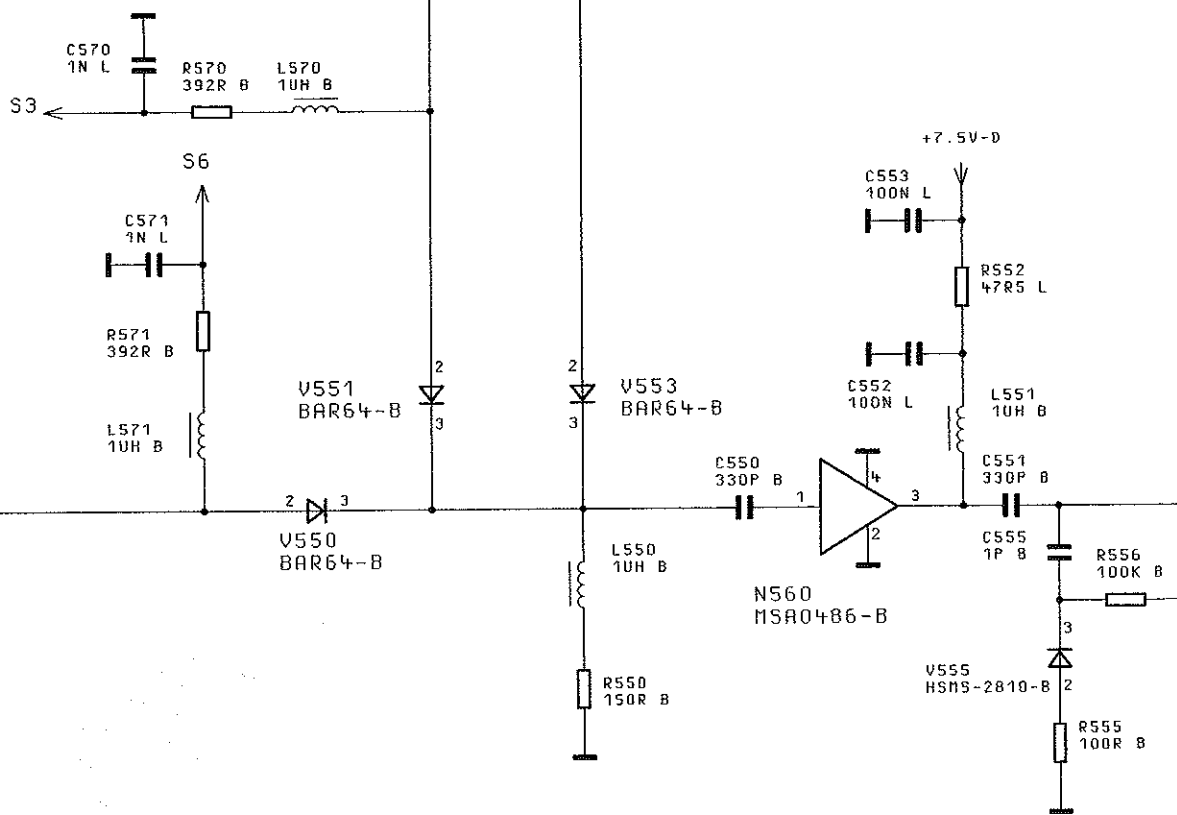

* NICHT BESTUECKT
NOT FITTED

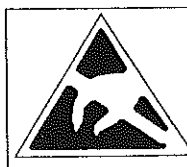

ACHTUNG: EGB!
ELEKTROSTATISCH GEFÄHRDETE
BAUELEMENTE ERFORDERN EINE
BESONDERE HANDHABUNG.
ATTENTION ESD!
ELECTROSTATIC SENSITIVE DEVICES
REQUIRE A SPECIAL HANDLING

DIANTEN,
ND
SIEHE SA.
MODELS,
LUES AND
ARTS LIST.

04/02		21.02.97	E I	MENP	TAG	NAME
				BEARB.		E I
				GEPR.		
				NORM		
				PLOTT	21.02.97	
04/01		02.12.96	WH			
REND. IND.	ÄNDERUNGS- MITTEILUNG	DATUM	NAME			
				ZU GERÄT		SMY

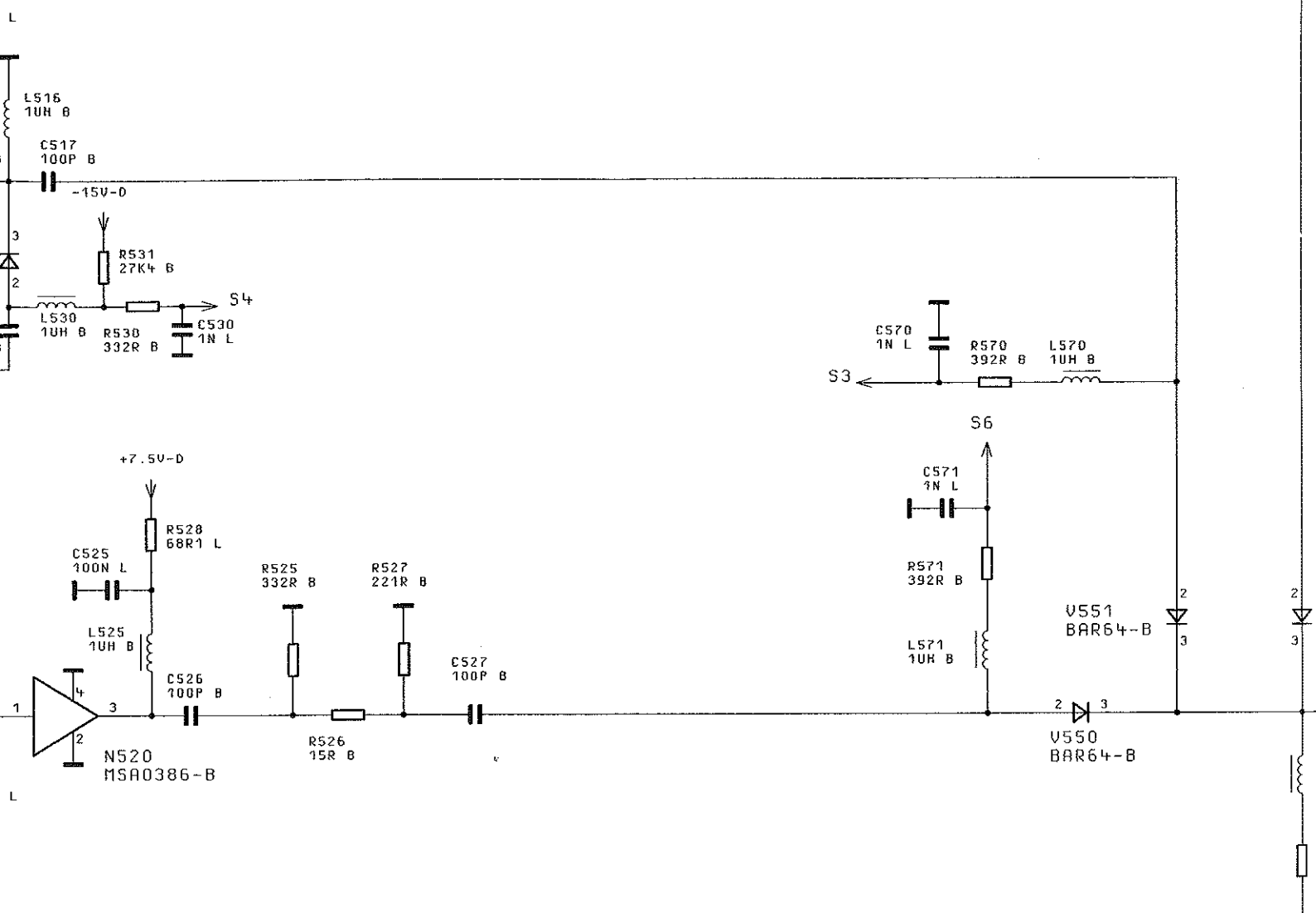

* NICHT BESTUECKT
NOT FITTED

BINDENDE ANGABEN UEBER VARIANTEN,
TRIMMWERTE, BAUTEILWERTE UND
NICHT BESTUECKTE BAUTEILE SIEHE SA.

FOR BINDING INFORMATION ON MODELS,
TRIMMING AND COMPONENTS VALUES AND
NONFITTED COMPONENTS SEE PARTS LIST.

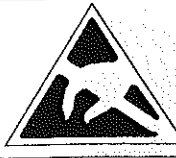

ACHTUNG: EGB!
ELEKTROSTATISCH GEFAHRDETE
BAUELEMENTE ERFORDERN EINE
BESONDERE HANDHABUNG.

ATTENTION ESD!
ELECTROSTATIC SENSITIVE DEVICES
REQUIRE A SPECIAL HANDLING

04/02	
04/01	
REND.	RENDER
IND.	ATTIC

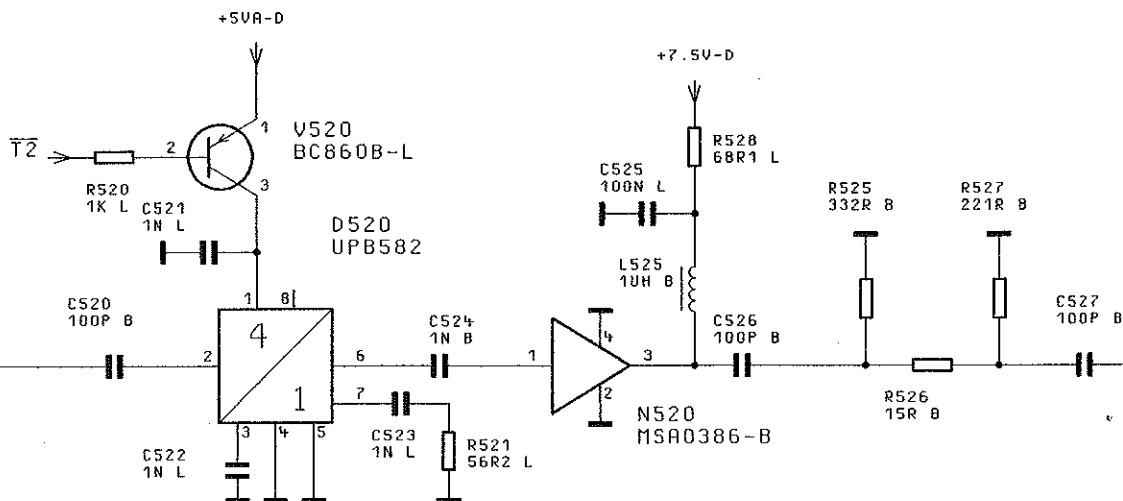
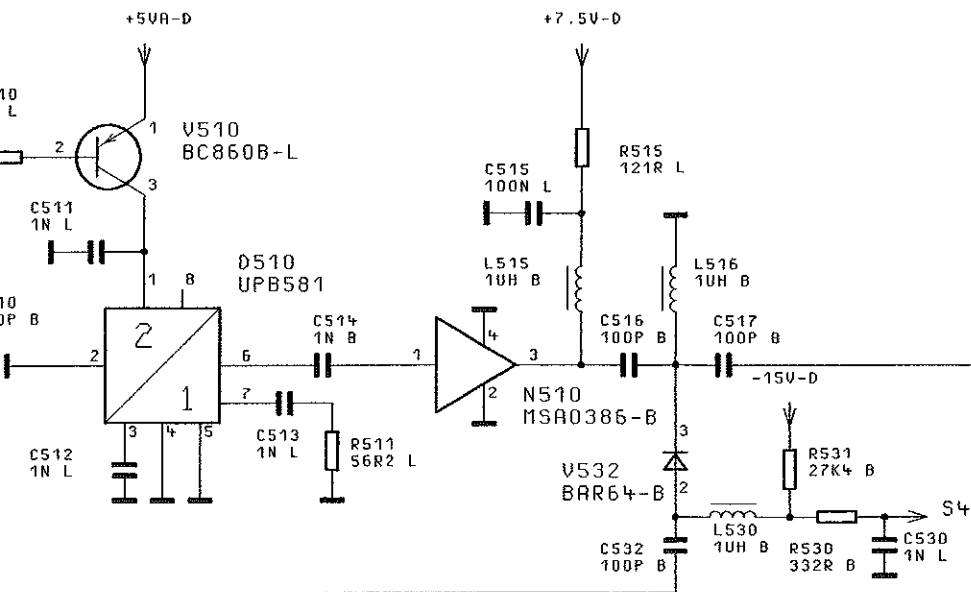

* NICHT BE
NOT FITTED

BINDENDE ANGABEN UEBER VARIANTEN,
TRIMMWERTE, BAUTEILWERTE UND
NICHT BESTUECKTE BAUTEILE SIEHE SA.

FOR BINDING INFORMATION ON MODELS,
TRIMMING AND COMPONENTS VALUES AND
NONFITTED COMPONENTS SEE PARTS LIST.



505
UH B

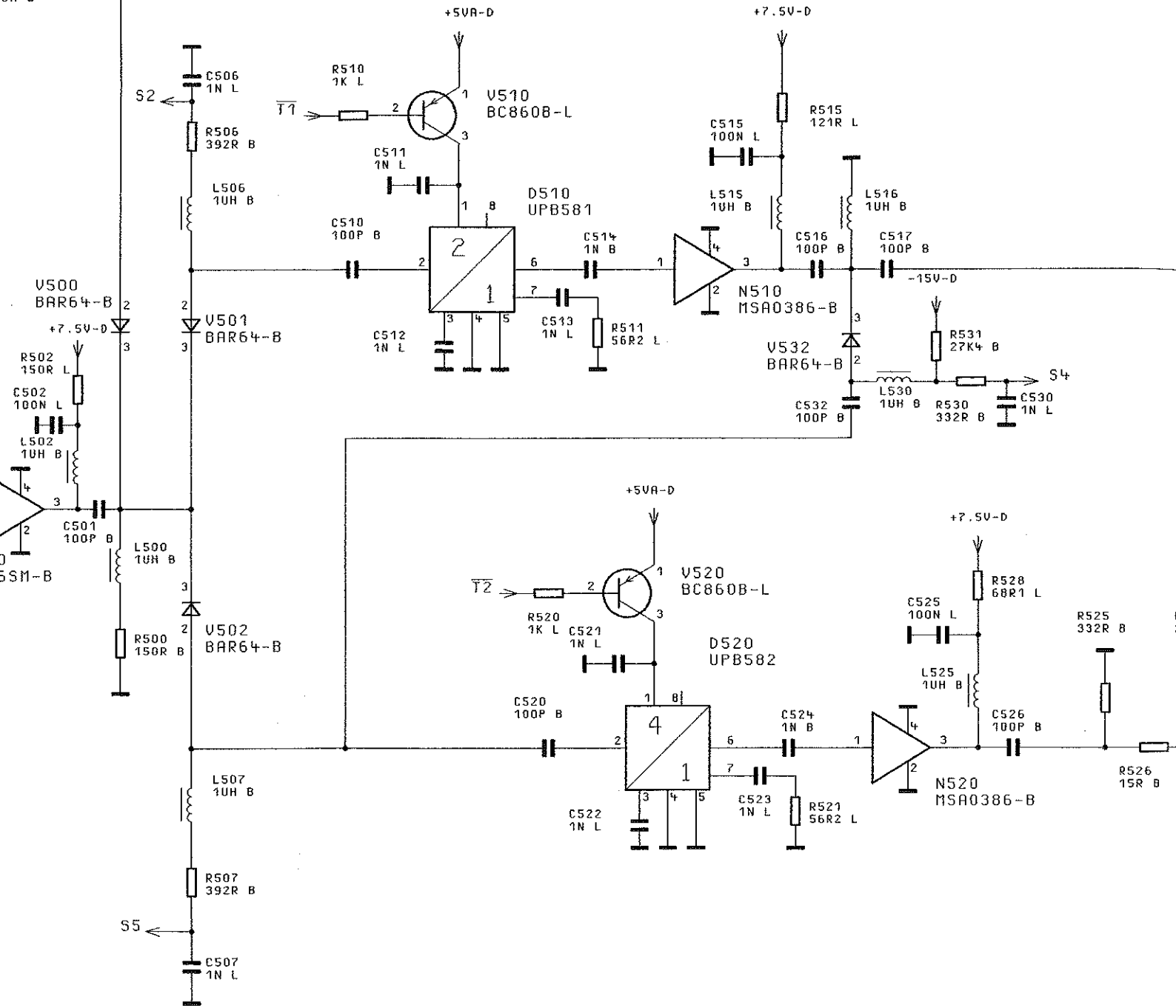

BINDENDE ANGABEN
TRIMMWERTE, BAU
NICHT BESTUECKT

FOR BINDING INFO
TRIMMING AND CO
NONFITTED COMPO

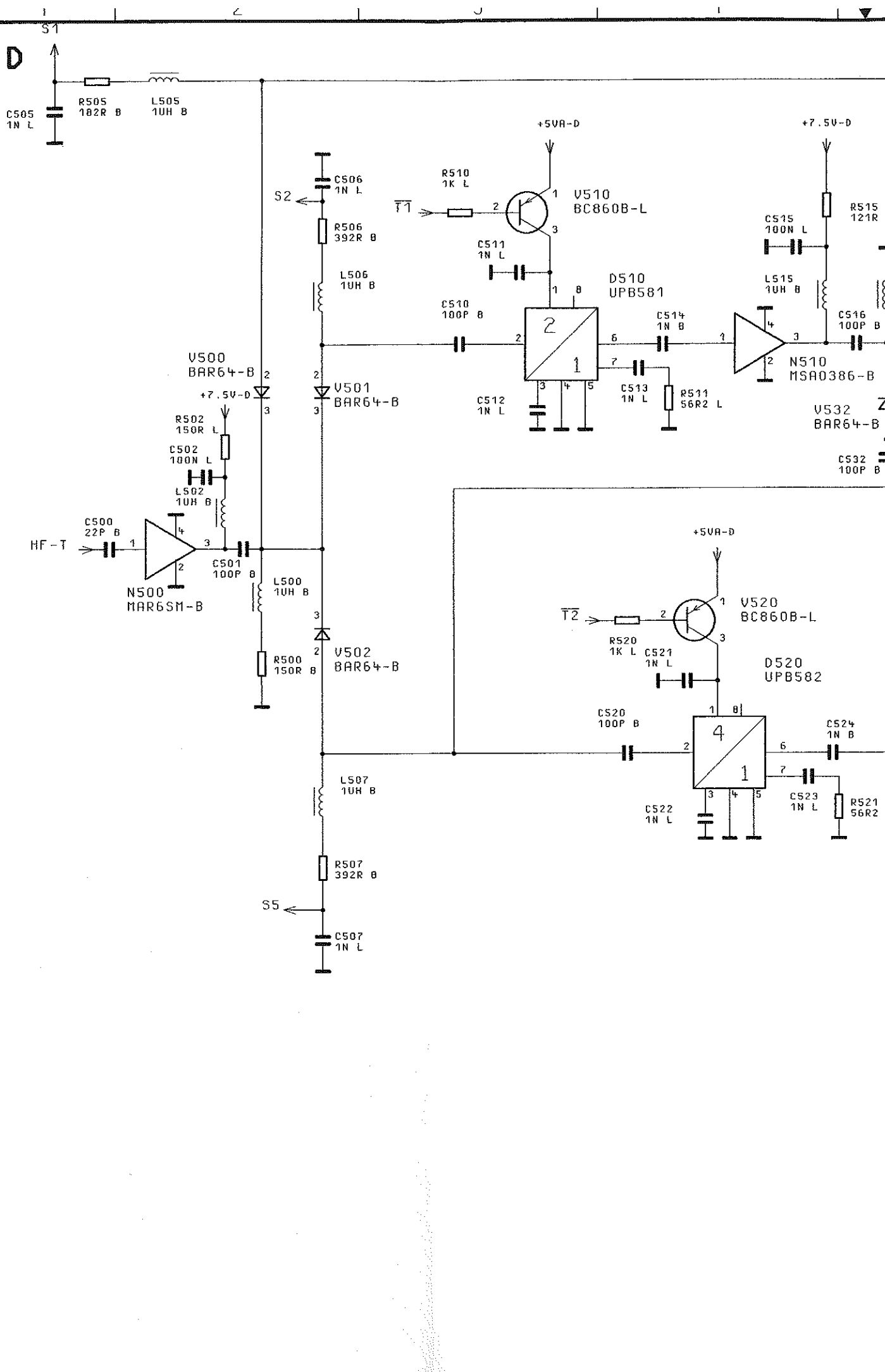

FUER DIESE UNTERLAGE
 BEHALTEN MIR UNS ALLE RECHTE VOR

ZEICHN.-NR. 1062.6409.01 S

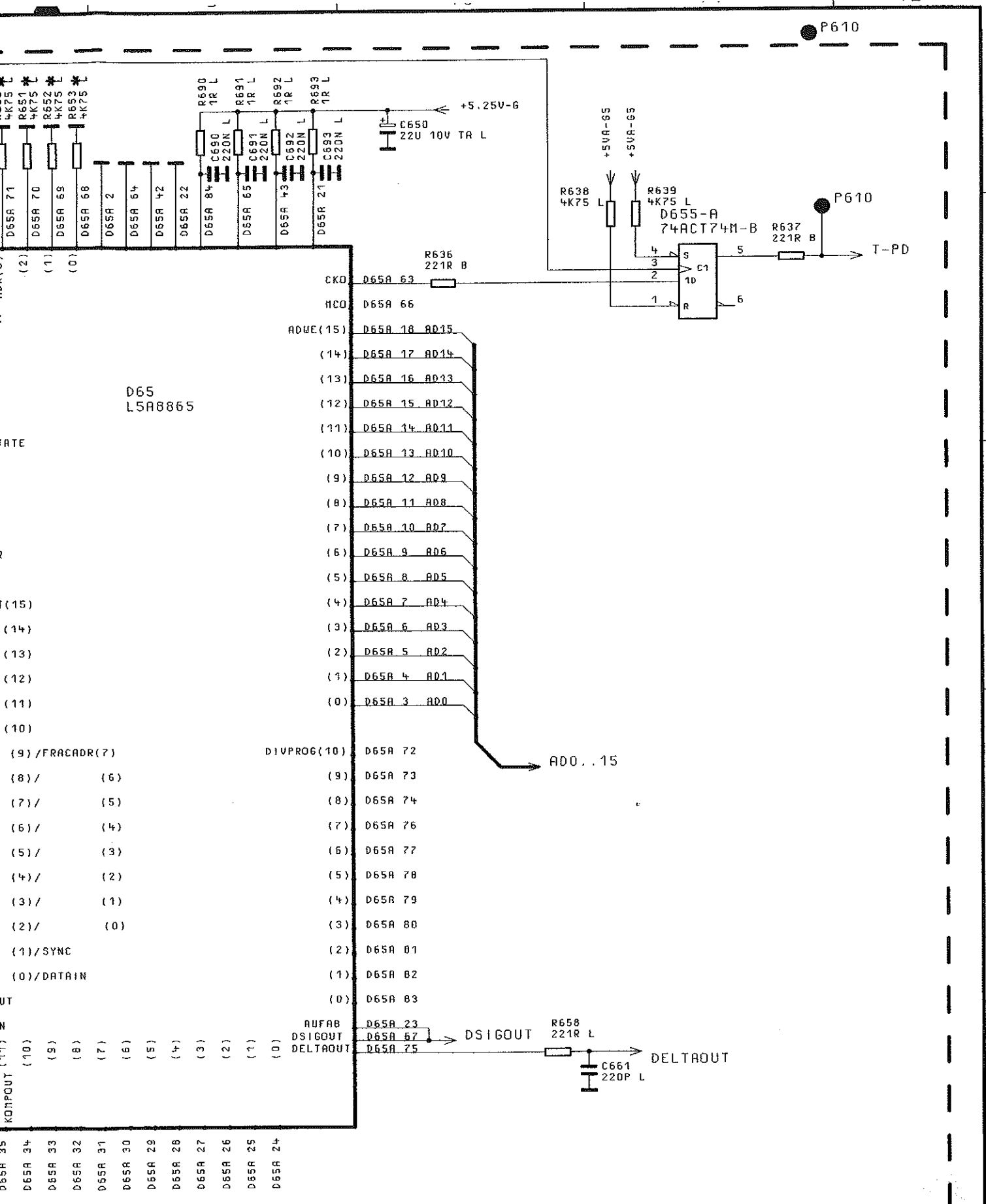

04/02	21.02.97	E I	MENP	TAG	NAME	BENENNUNG
			BEARB.		E I	SYNTHESIZER SYNTHESIZER
			GEPR.			
			NORM			
			PLOTT	21.02.97		
04/01	02.12.96	W H				ZEICHN.-NR.
REND. IND.	ÄNDERUNGS-MITTEILUNG	DATUM				NAME
			ZU GERÄT	SMY	REG. I. V.	1062.5502
					ERST. Z.	1062.5502

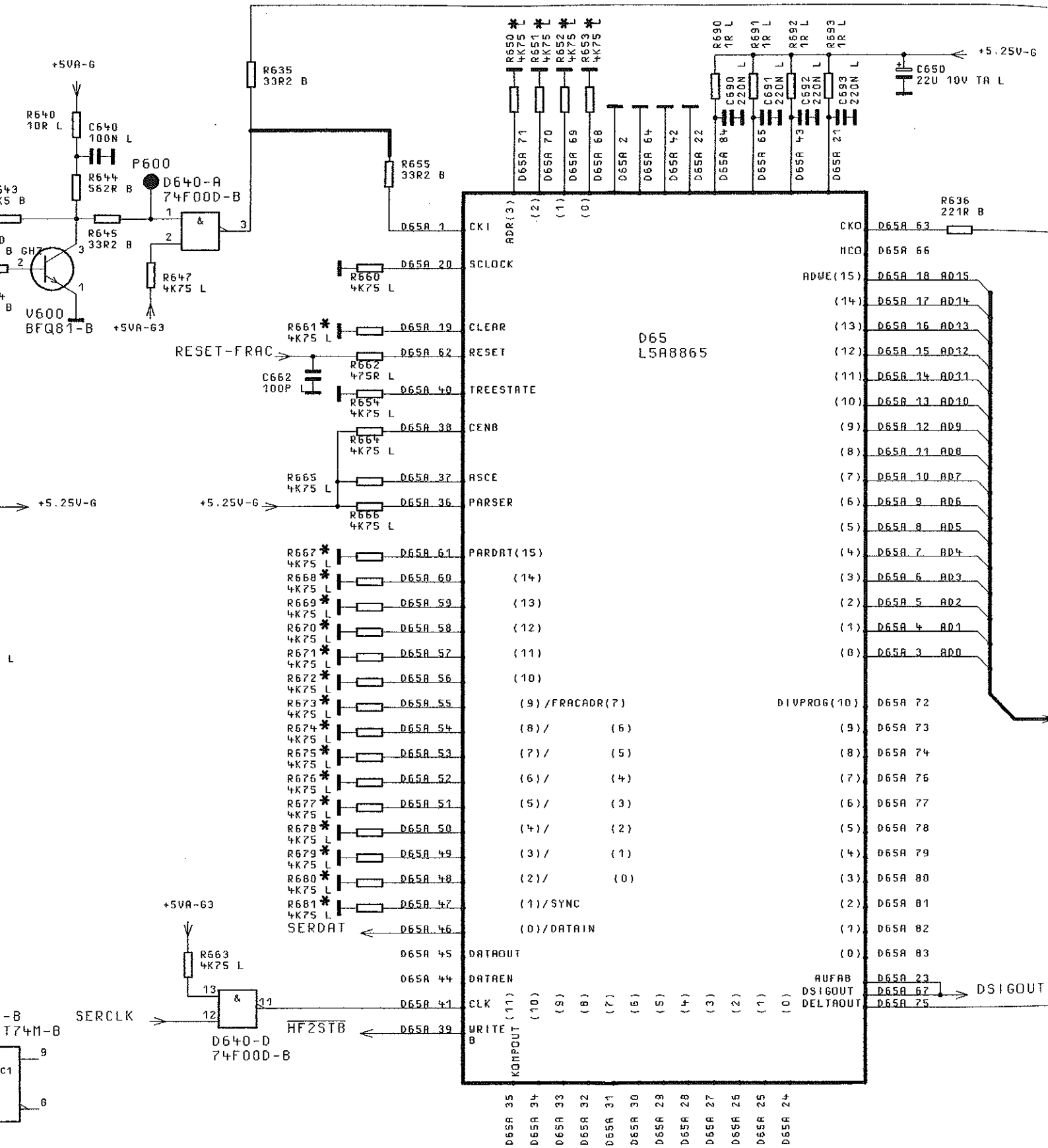

*** NICHT BESTUECKT**

NOT FITTED

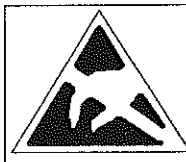

ACHTUNG: EGB!
ELEKTROSTATISCH GEFÄHRDETE
BAUELEMENTE ERFORDERN EINE
BESONDERE HANDHABUNG.
ATTENTION ESD!
ELECTROSTATIC SENSITIVE DEVICES
REQUIRE A SPECIAL HANDLING

UEBER VARIANTEN,
ILWERTE UND
BAUTEILE SIEHE SA.
FORMATION ON MODELS,
ONENTS VALUES AND
ENTS SEE PARTS LIST.

04/02		21.02.97	E I	MENP	TAB	NAME
				BEARB.		E I
				GEPR.		
				NDRH		
				PLOTT	21.02.97	
04/01		02.12.96	WH			
REND. IND.	BEREICHUNG- MITTEILUNG	DATUM	NAME	 ZU GERÄT: SMY		

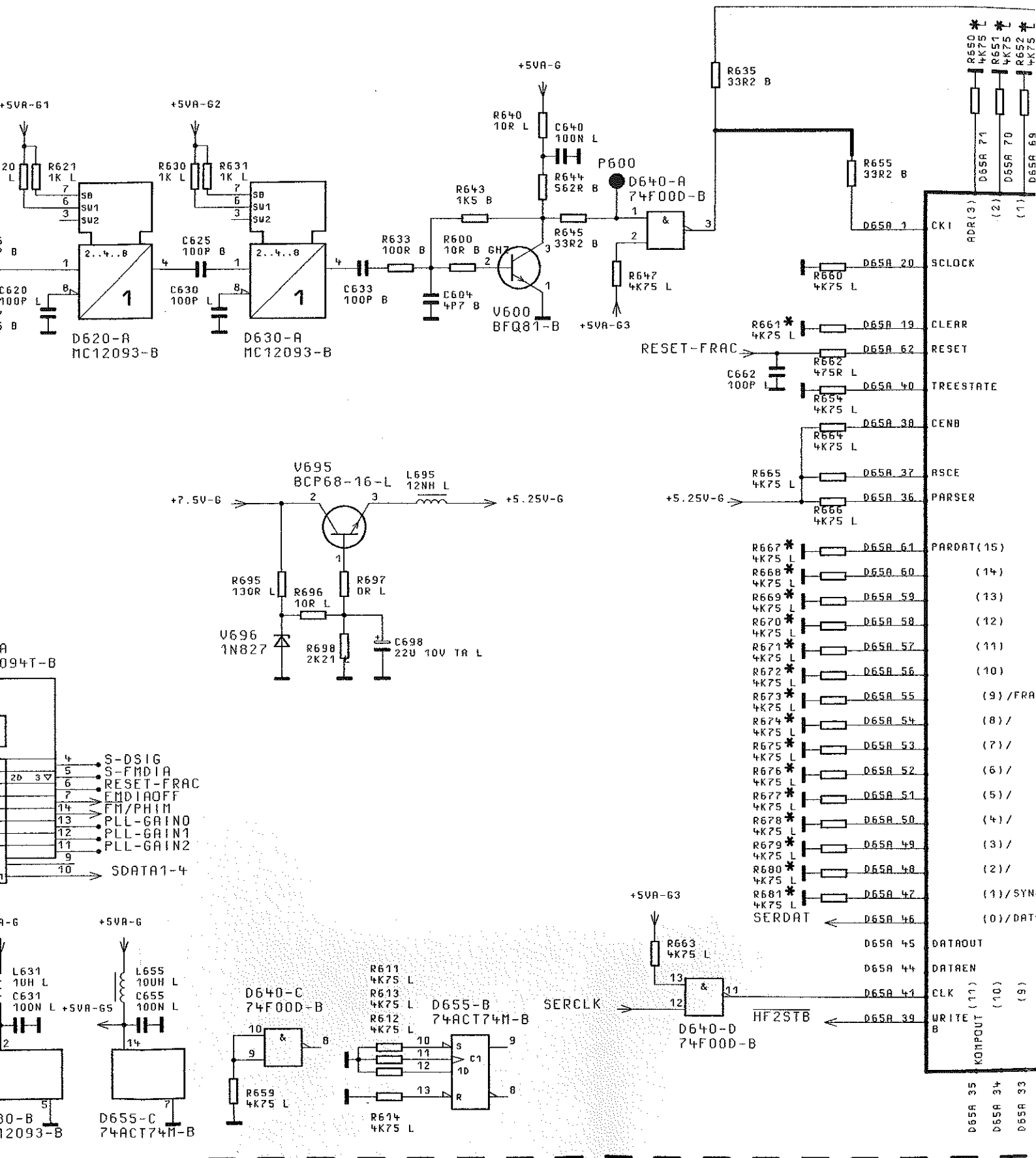

* NICHT BESTUECKT

NOT FITTED

BINDENDE ANGABEN UEBER VARIANTEN, TRIMMWERTE, BAUTEILWERTE UND NICHT BESTUECKTE BAUTEILE SIEHE SA.
 FOR BINDING INFORMATION ON MODELS, TRIMMING AND COMPONENTS VALUES AND NONFITTED COMPONENTS SEE PARTS LIST.

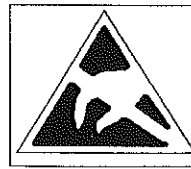

ACHTUNG: EGB!
 ELEKTROSTATISCH GEFAEHRDETE BAUELEMENTE ERFORDERN EINE BESONDERE HANDHABUNG.
 ATTENTION ESD!
 ELECTROSTATIC SENSITIVE DEVICES REQUIRE A SPECIAL HANDLING

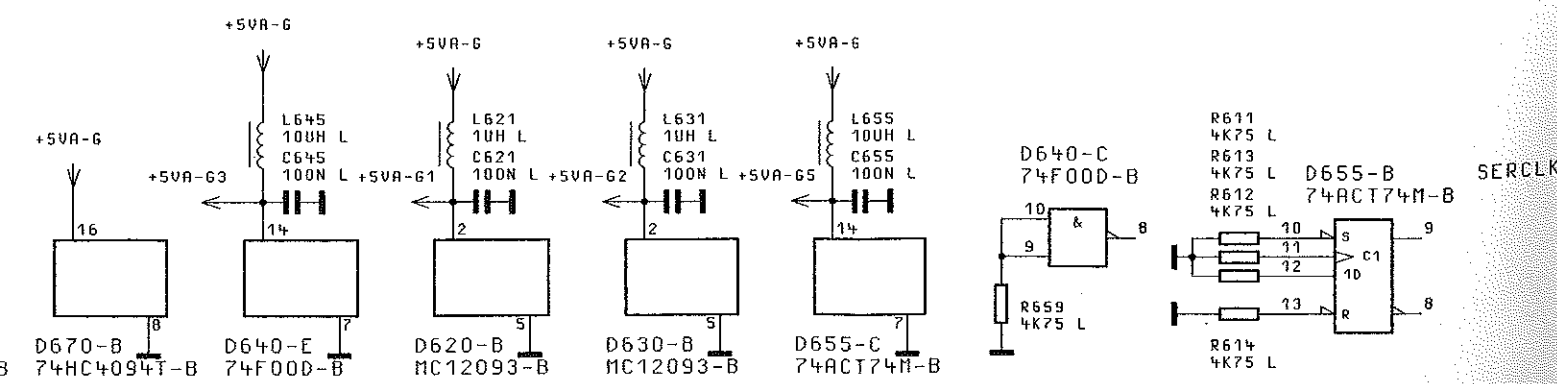
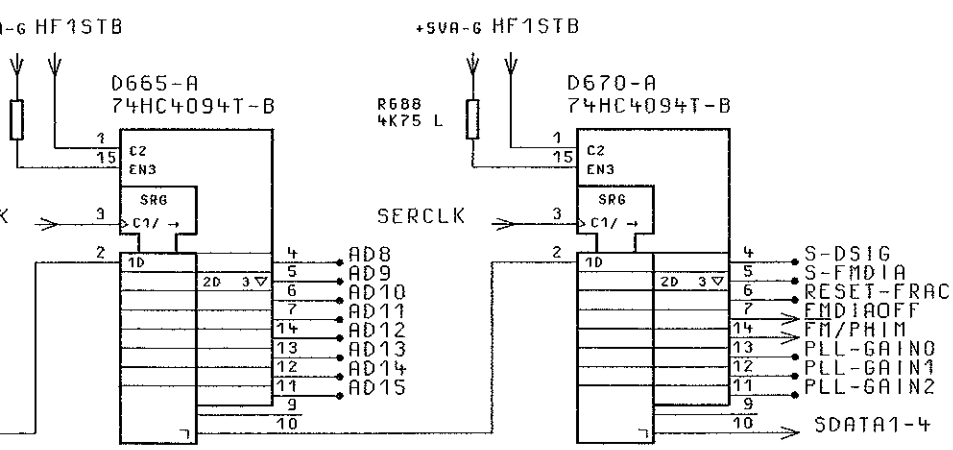
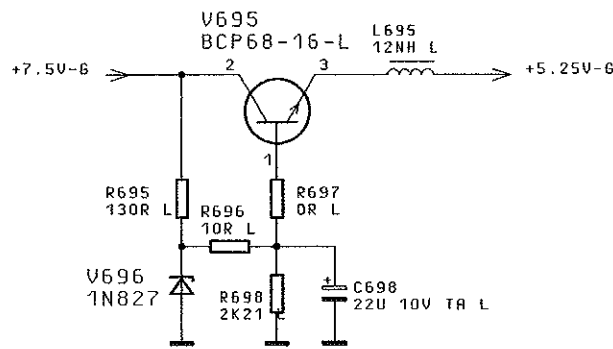
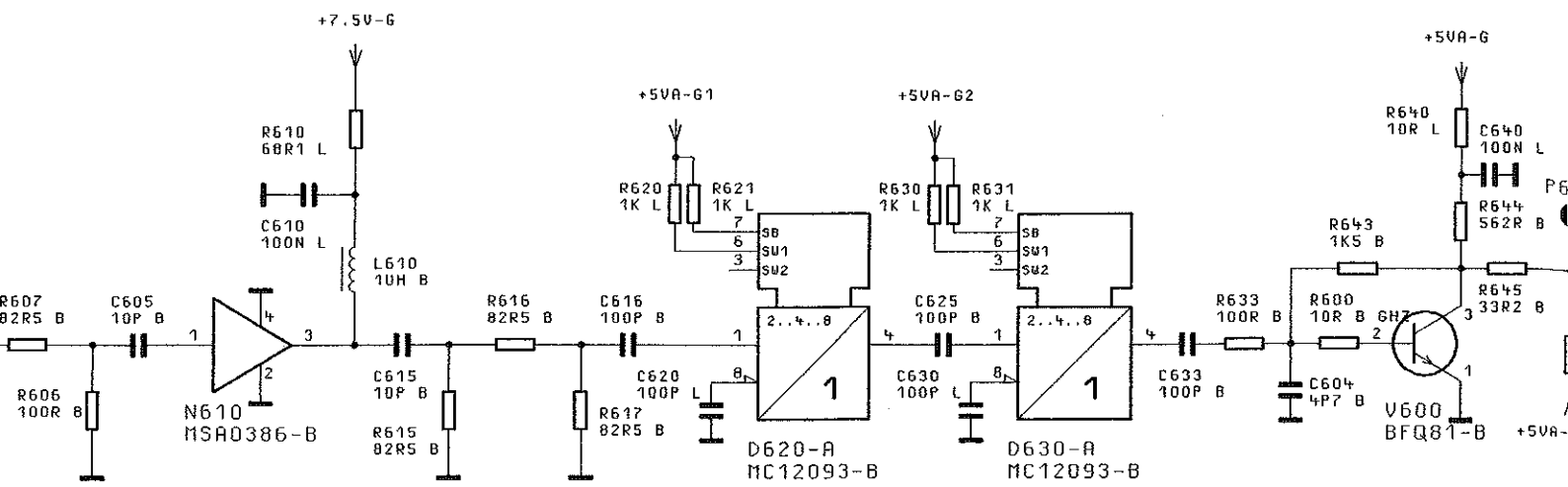

BINDENDE ANGABEN UEBER VARIANTEN,
 TRIMMWERTE, BAUTEILWERTE UND
 NICHT BESTUECKTE BAUTEILE SIEHE SA.
 FOR BINDING INFORMATION ON MODELS,
 TRIMMING AND COMPONENTS VALUES AND
 NONFITTED COMPONENTS SEE PARTS LIST.

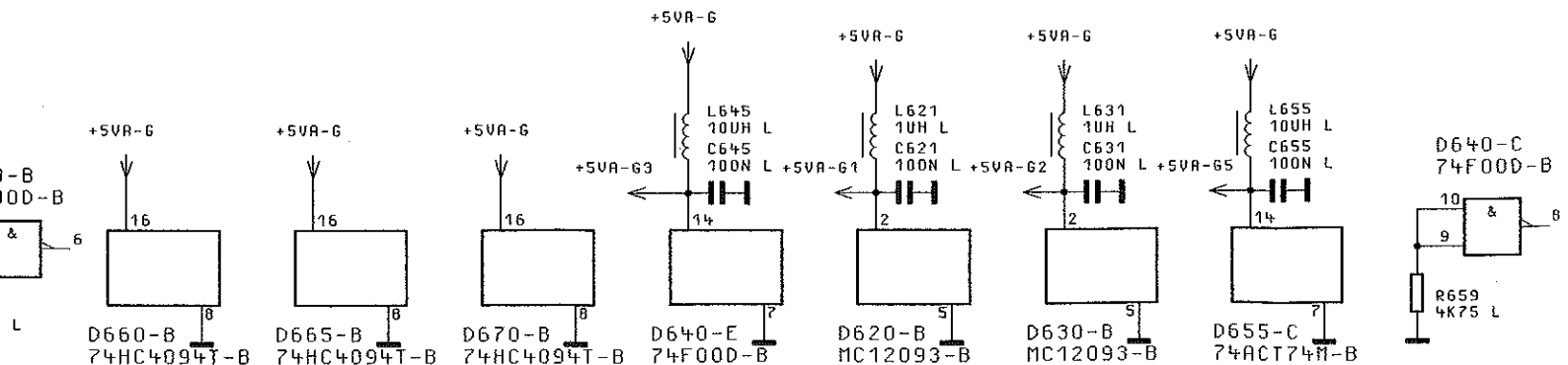
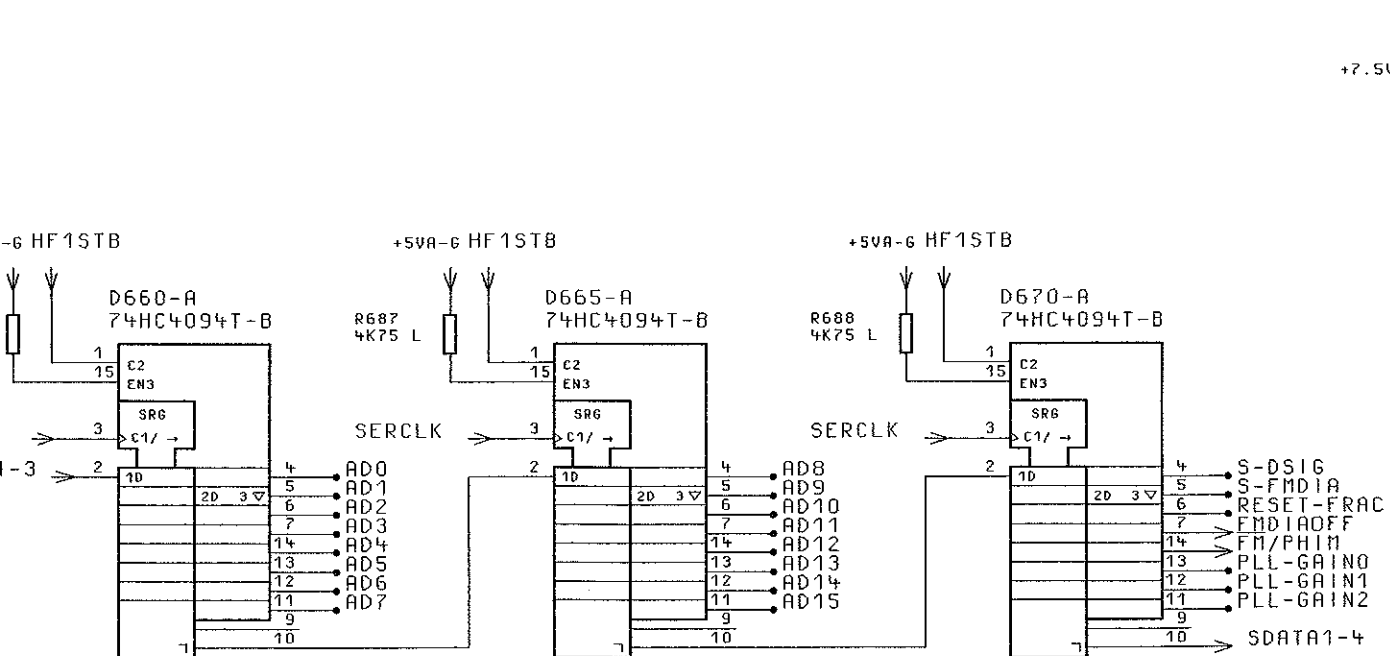
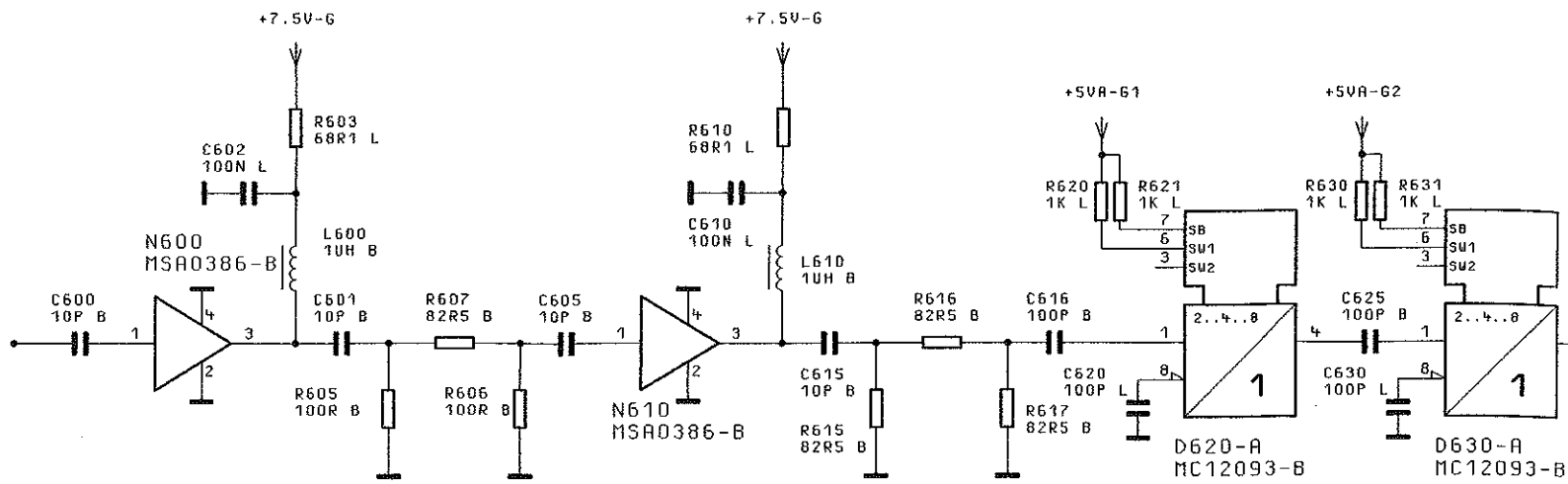

G

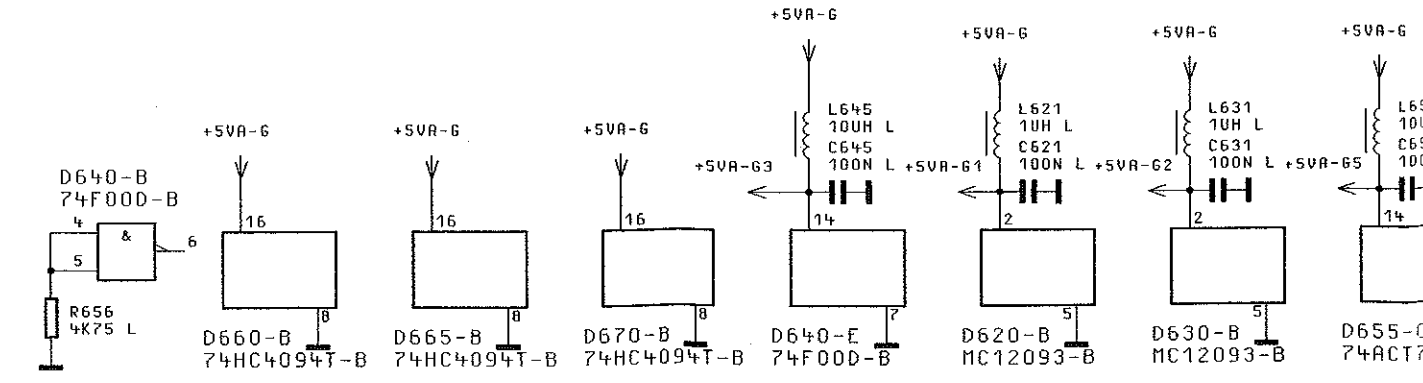
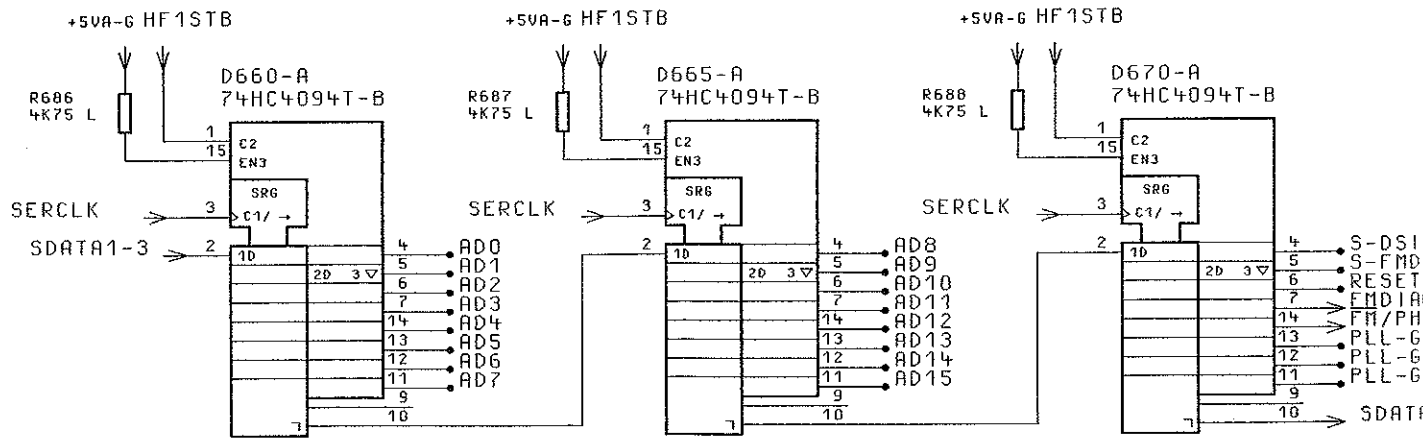
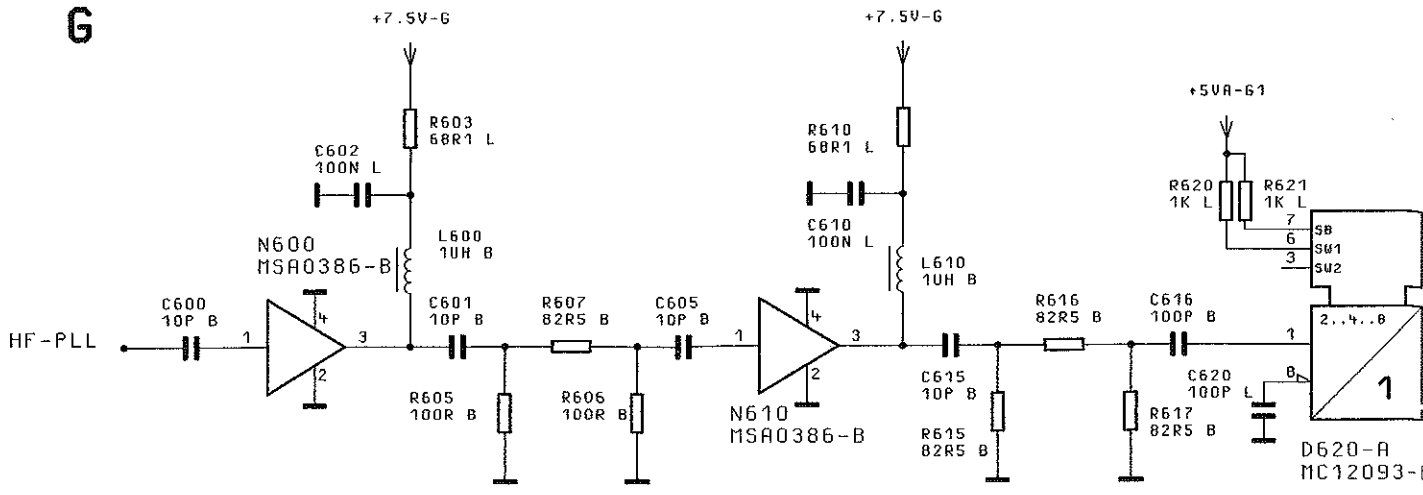

BEHALTEN WIR UNS ALLE RECHTE VOR

1

2

3

4

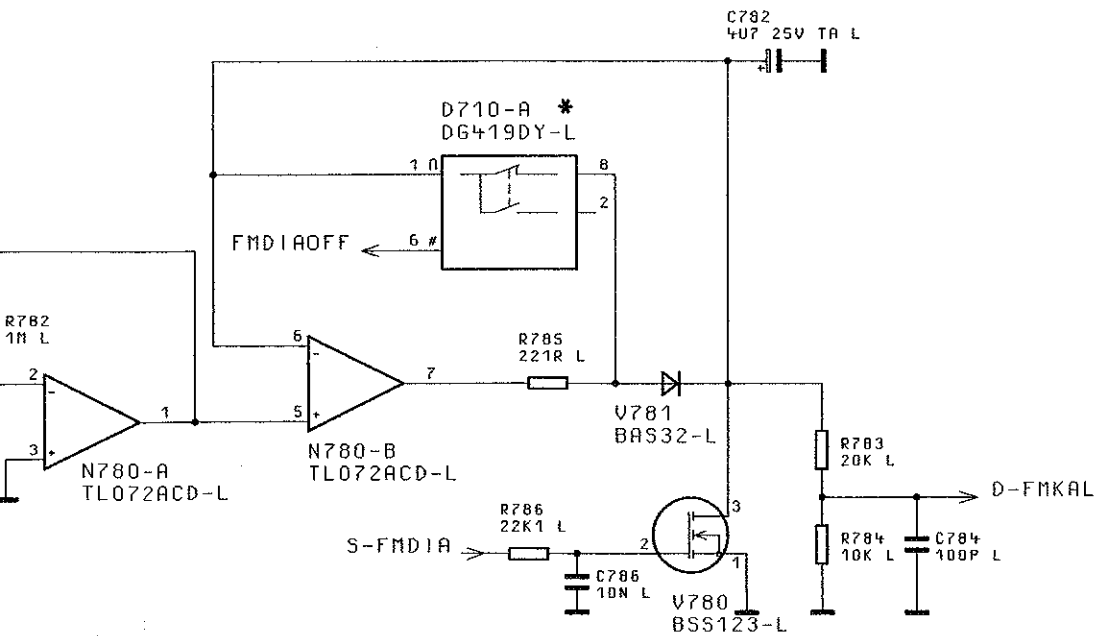
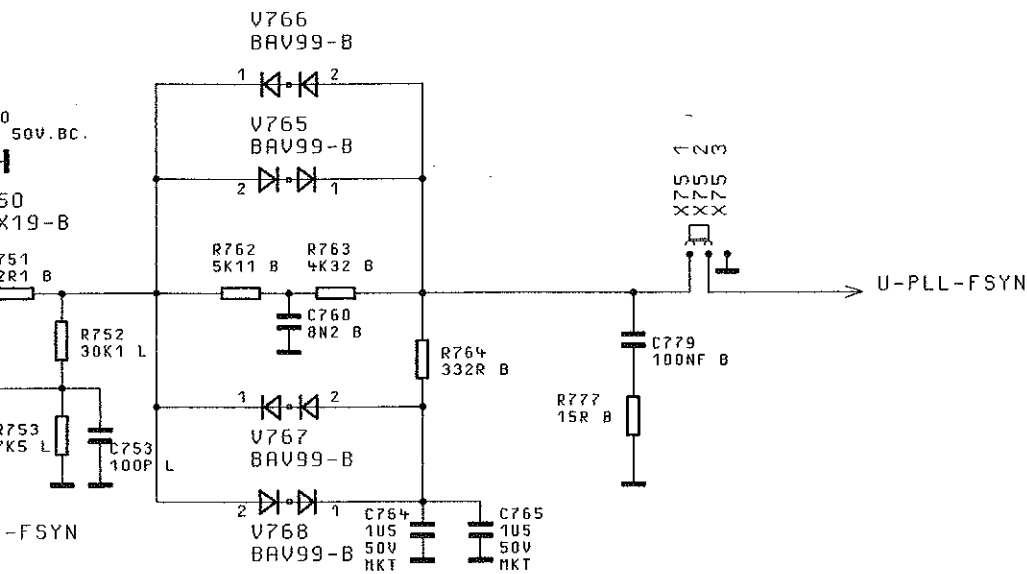

04/02	21.02.97	E I	MENP	TAG	NAME	BENENNUNG	
			BEARB.		E I	SYNTHESIZER SYNTHESIZER	
			GEPR.				
			NORM				
			PLOTT	21.02.97			
04/01	02.12.96	WH		ROHDE & SCHWARZ		ZEICHN.-NR.	BLATT-NR.
ÄNDERUNGS- IND.	ÄNDERUNGS- MITTEILUNG	DATUM		NAME			1062.6409.01S
			ZU GERÄT	SMY	REG. I. V.	1062.5502	ERSTE Z.
						1062.5502	12

- R721 121K B
- R722 27K4 B
- R723 15K B
- R724 9K09 B
- R725 6K19 B
- R726 4K75 B
- R727 3K57 B

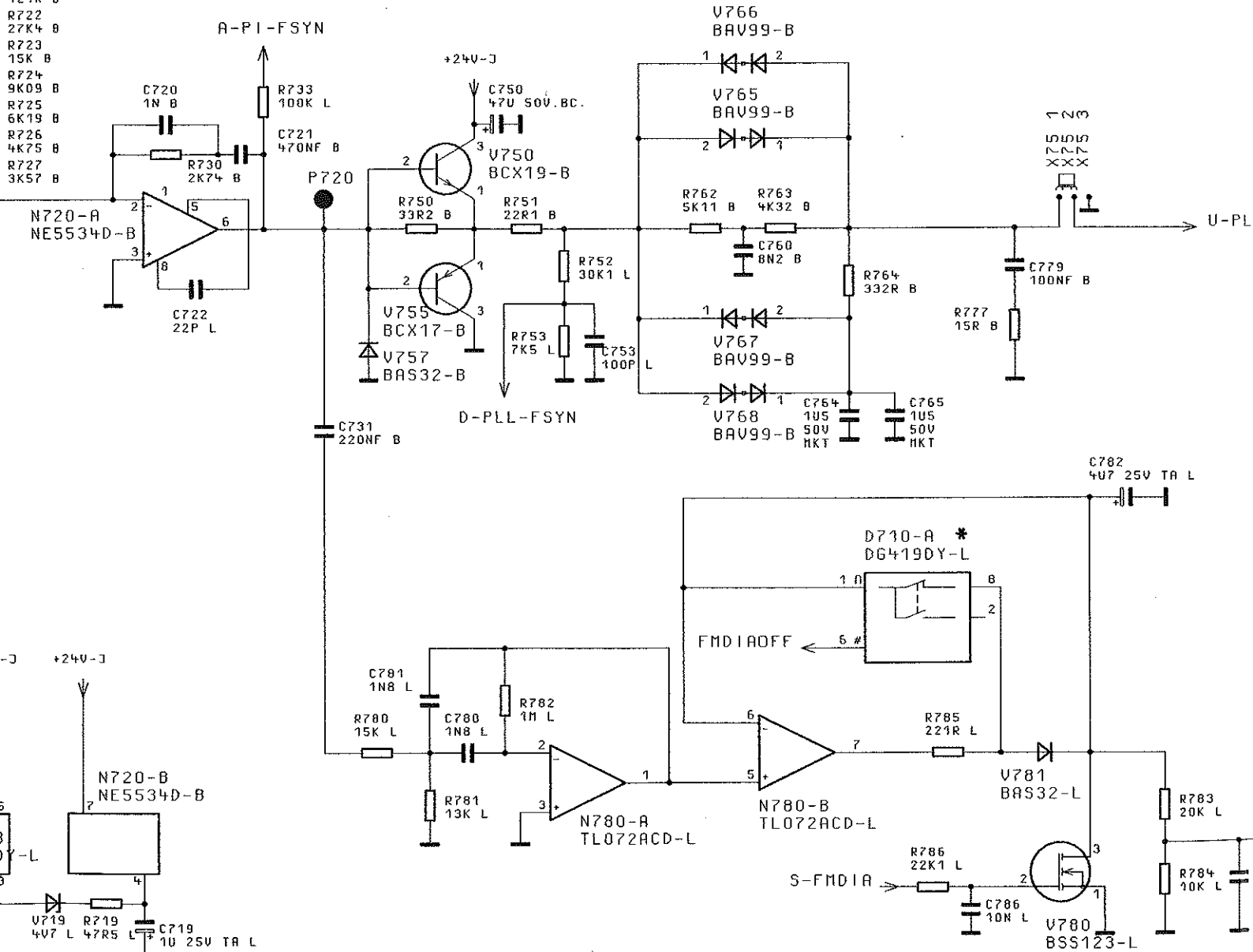

Bindende Angaben über Varianten, Trimmwerte, Bauteilwerte und nicht bestückte Bauteile siehe SA

For binding information on models, trimming and components values and nonfitted components see parts list.

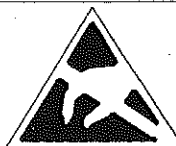

ACHTUNG: EGB!
ELEKTROSTATISCH GEFÄHRDETE
BAUELEMENTE ERFORDERN EINE
BESONDERE HANDHABUNG.

ATTENTION ESD!
ELECTROSTATIC SENSITIVE DEVICES
REQUIRE A SPECIAL HANDLING

04/02		21.02.97	E I	MENP	TAG	NAME	BENENNUNG
				BEARB.		E I	
				GEPR.			
				NORM			
				PLOTT	21.02.97		
04/01		02.12.96	WH				ZEICHN.
ÄND. IND.	ÄNDERUNGS-MITTEILUNG	DATUM	NAME	ROHDE & SCHWARZ			
						20 GERÄT	SMY

UECKT

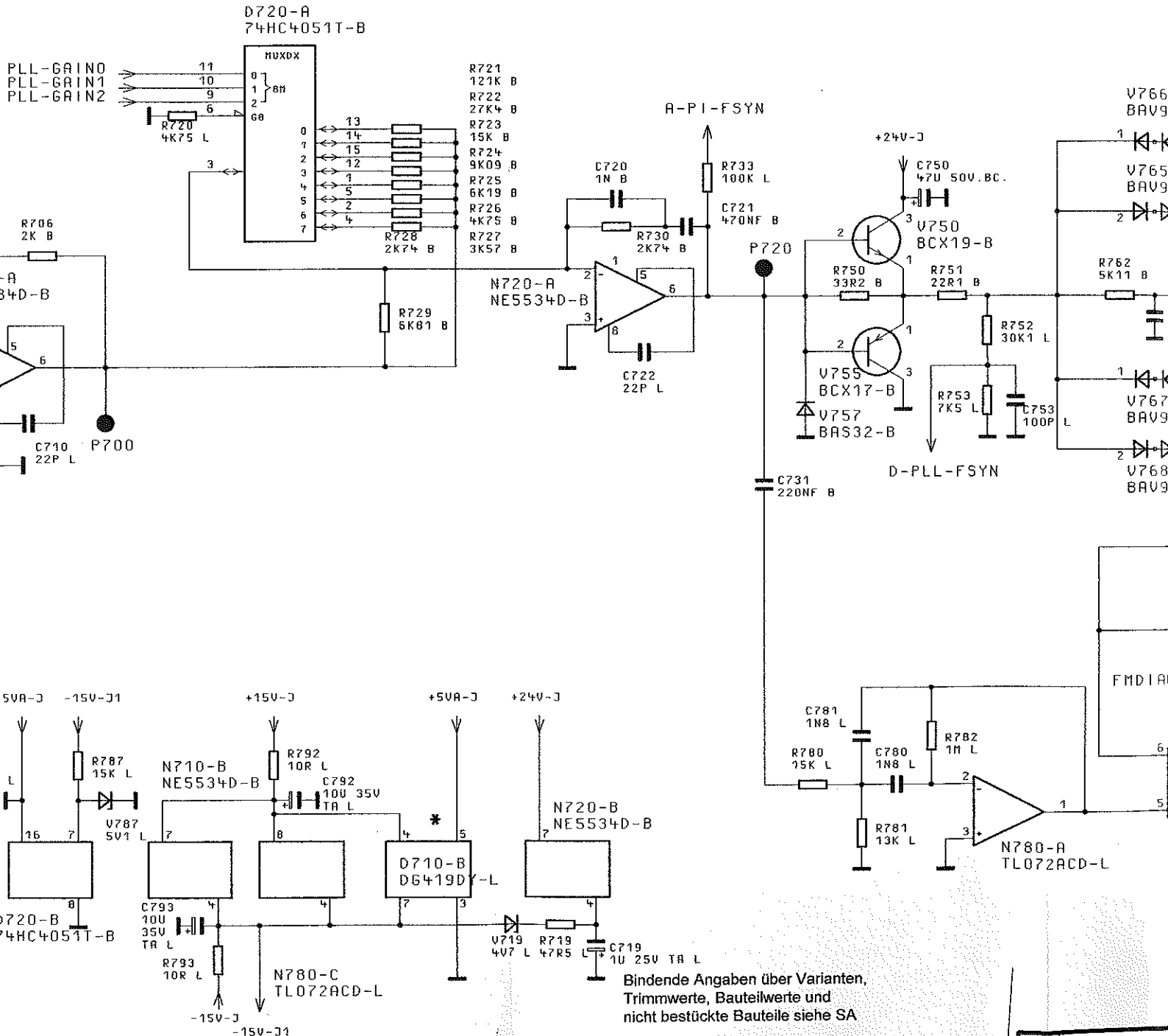

Bindende Angaben über Varianten, Trimmwerte, Bauteilwerte und nicht bestückte Bauteile siehe SA

For binding information on models, trimming and components values and nonfitted components see parts list.

*** NICHT BESTUECKT**
NOT FITTED

ACHTUNG: EGB!
ELEKTROSTATISCH GEFÄHRDETE BAUELEMENTE ERFORDERN EINE BESONDERE HANDhabUNG.

ATTENTION ESD!
ELECTROSTATIC SENSITIVE DEVICES REQUIRE A SPECIAL HANDLING

04/02	
04/01	
REND.	ÄNDERUNGS
IND.	MITTEILUNG

J

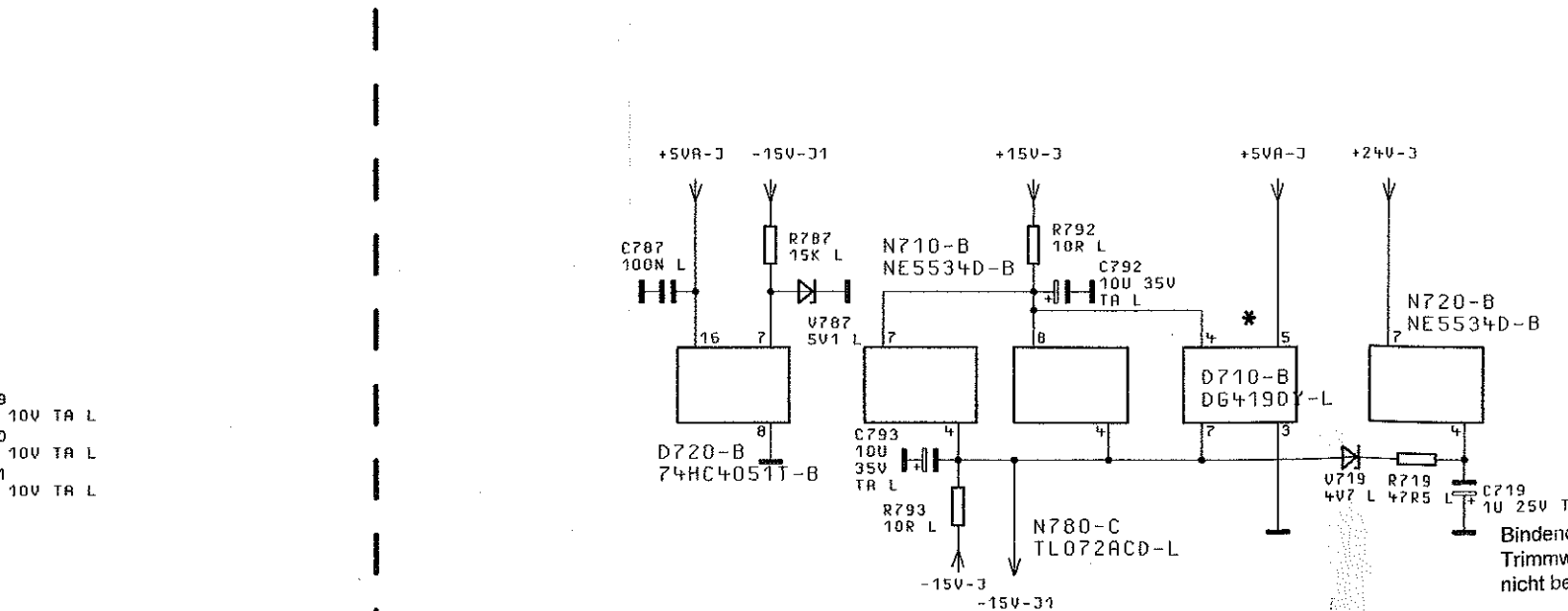
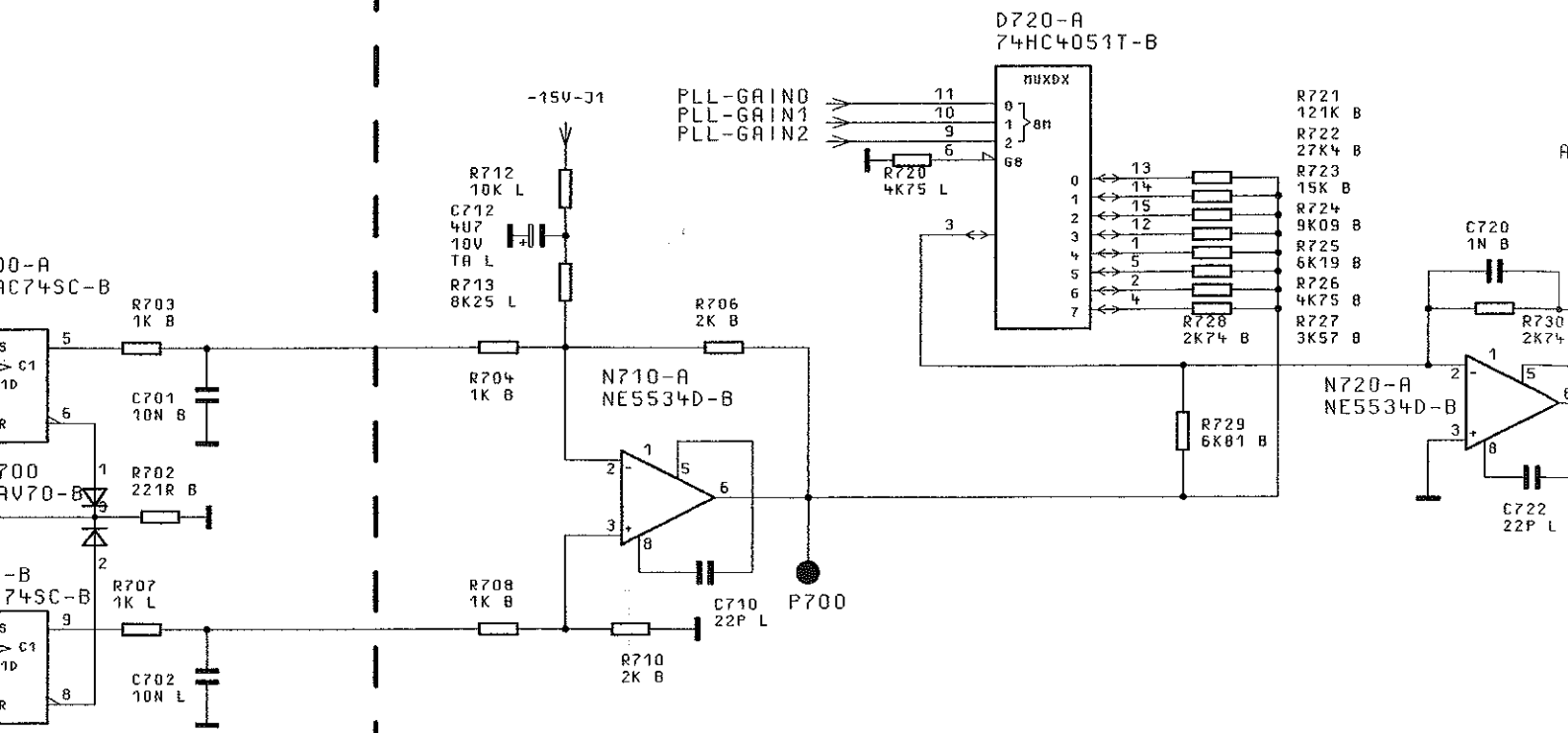

* NICHT BESTUECKT
NOT FITTED

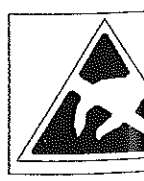

Binden
Trimmw
nicht be

For bin
trimmin
nonfite

J

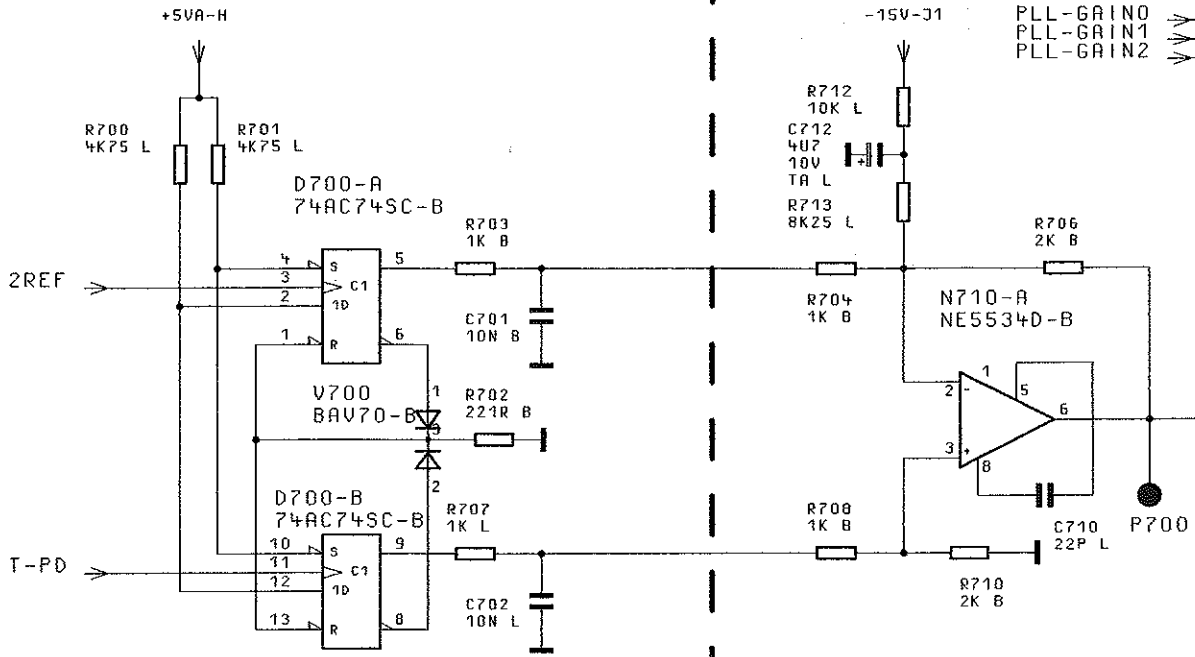

D720-74HC4

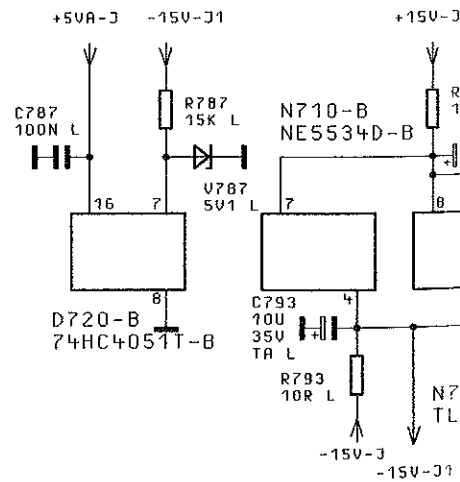
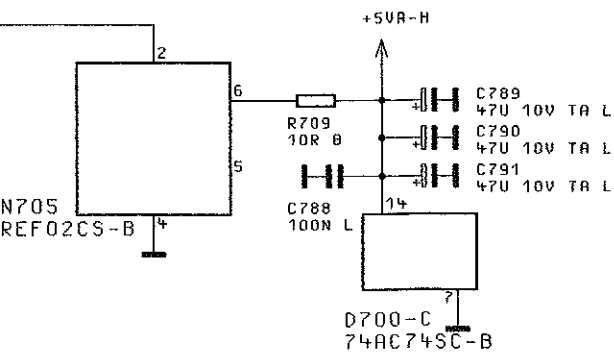
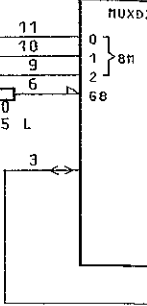

*

H

J

FUER DIESE UNTERLAGE
BEHALTEN MIR UNS ALLE RECHTE VOR

ZEICHN.-NR. 1062.6409.01 S

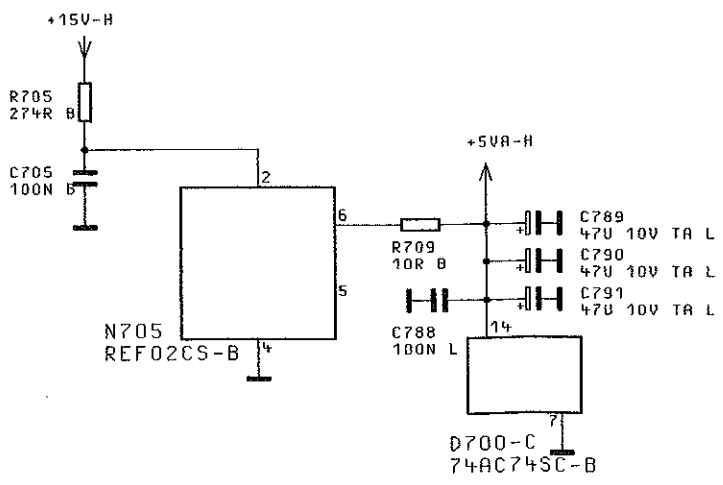
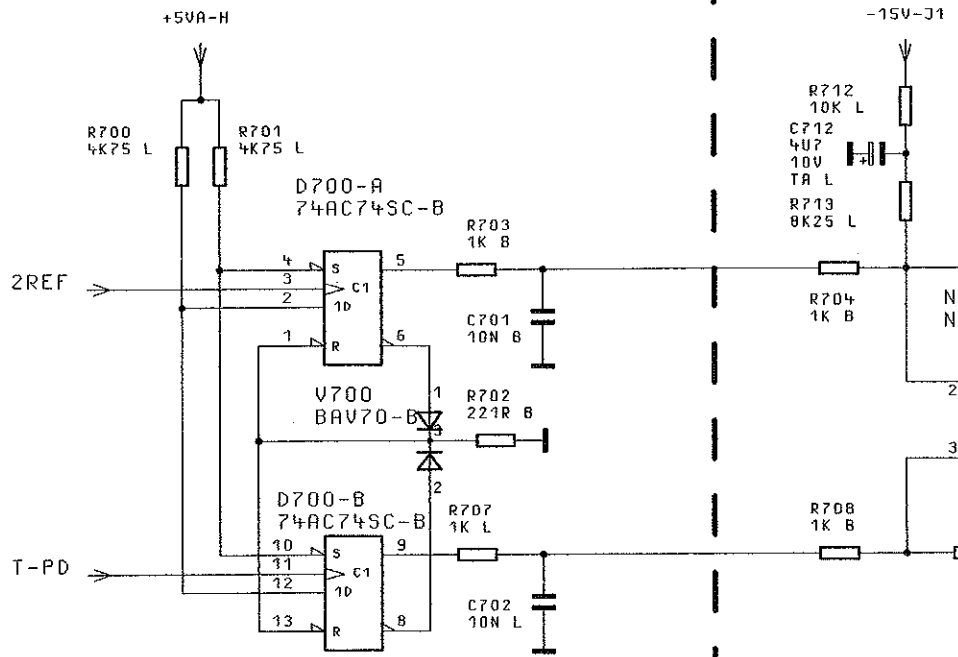

1 2 3 4

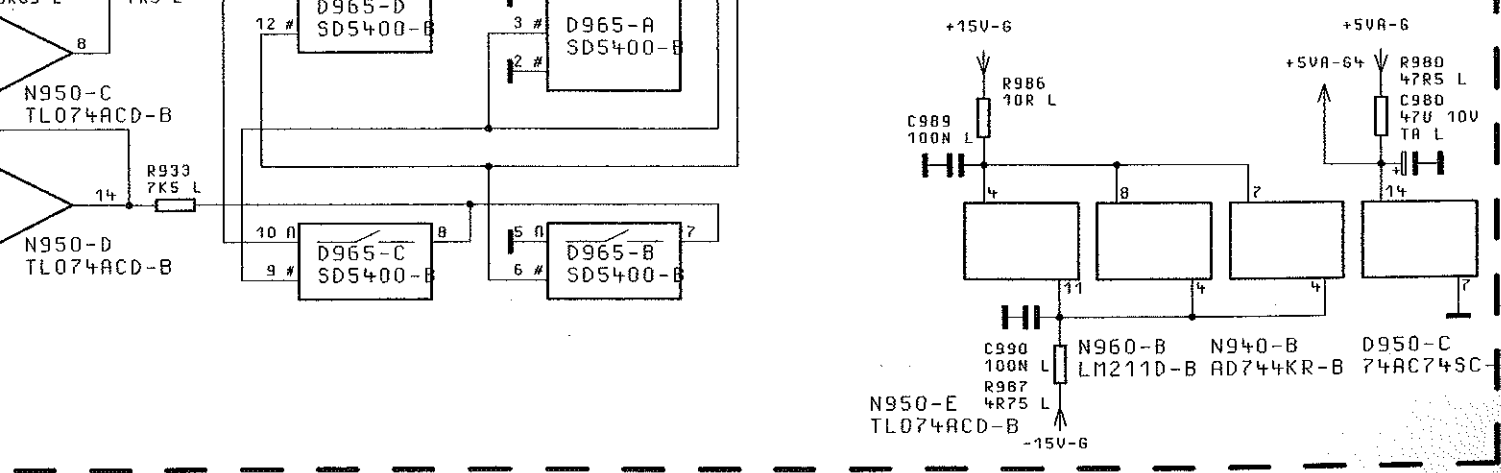
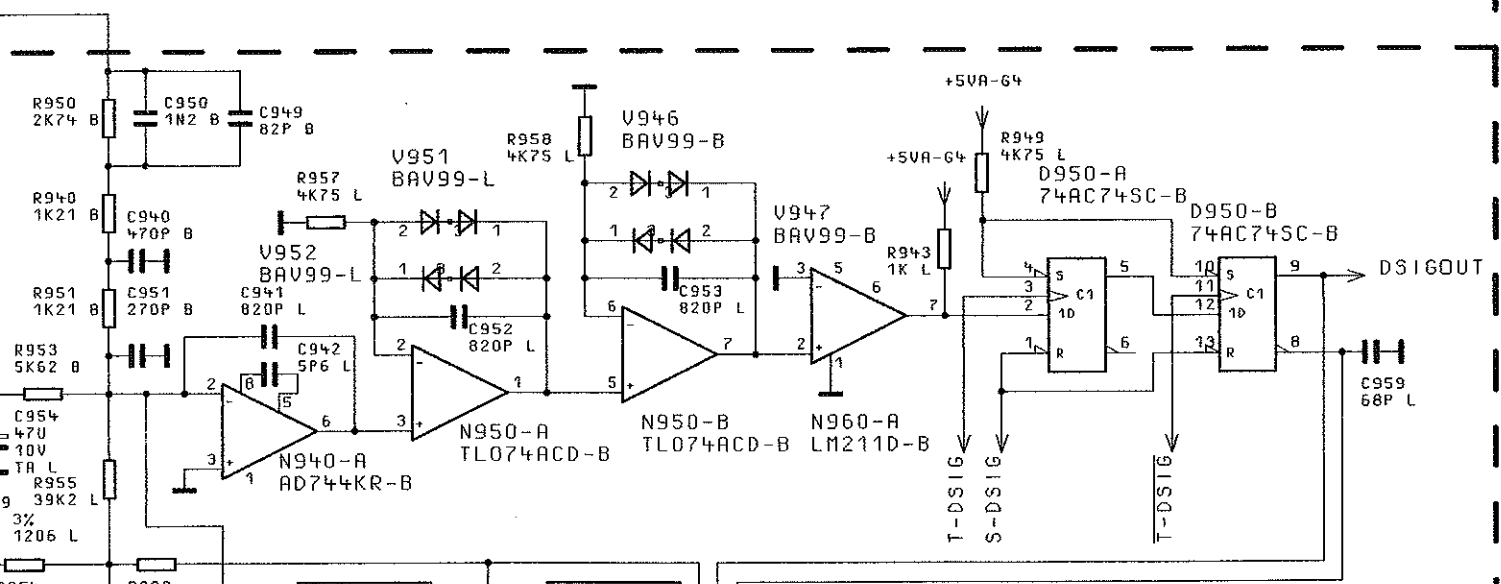
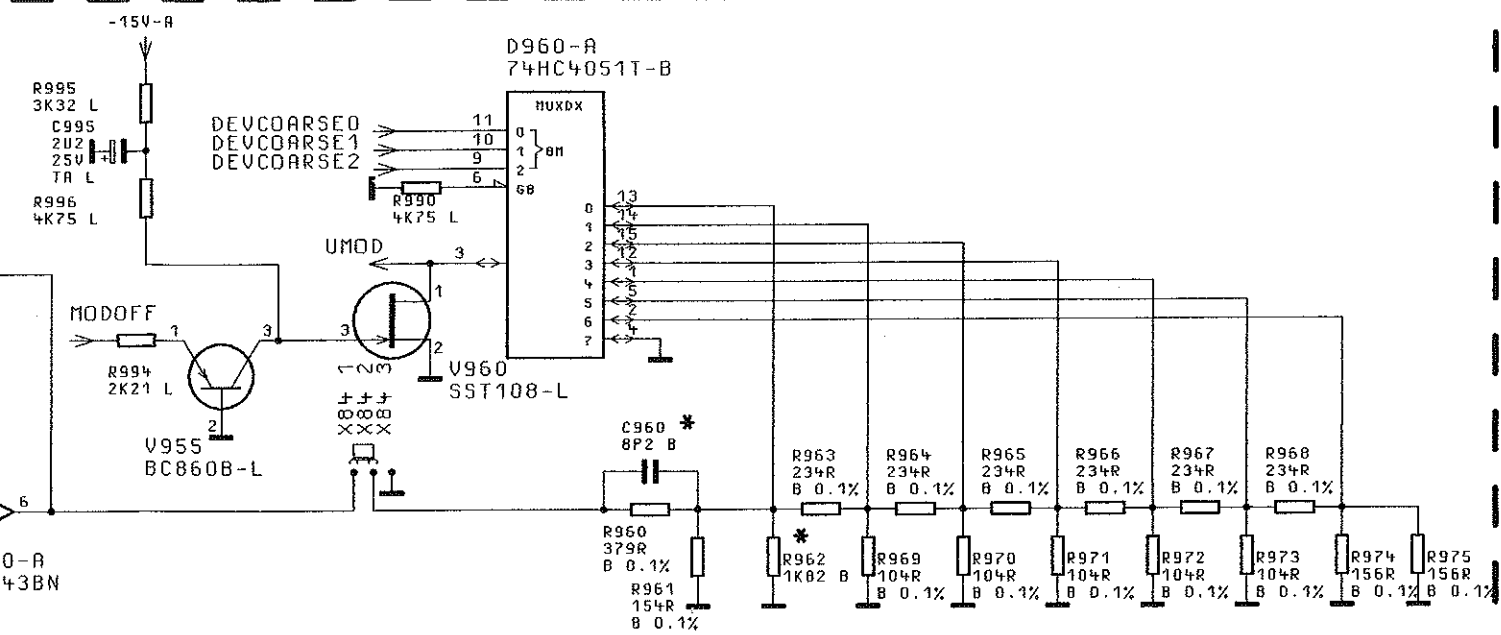

04/02	21.02.97	E I	MENP	TAG	NAME	BENENNUNG		
			BEARB.		E I	SYNTHESIZER SYNTHESIZER		
			GEPR.					
			NORM					
			PLOTT	21.02.97				
04/01	02.12.96	WH			ZEICHN.-NR.	BLATT-NR.		
BEND. IND.	BEREICHUNGSMITTEILUNG	DATUM			NAME	1062.6409.015	8+	
			ZB GERÄT	SMY	REG. I. V.	1062.5502	ERSTE Z.	1062.5502

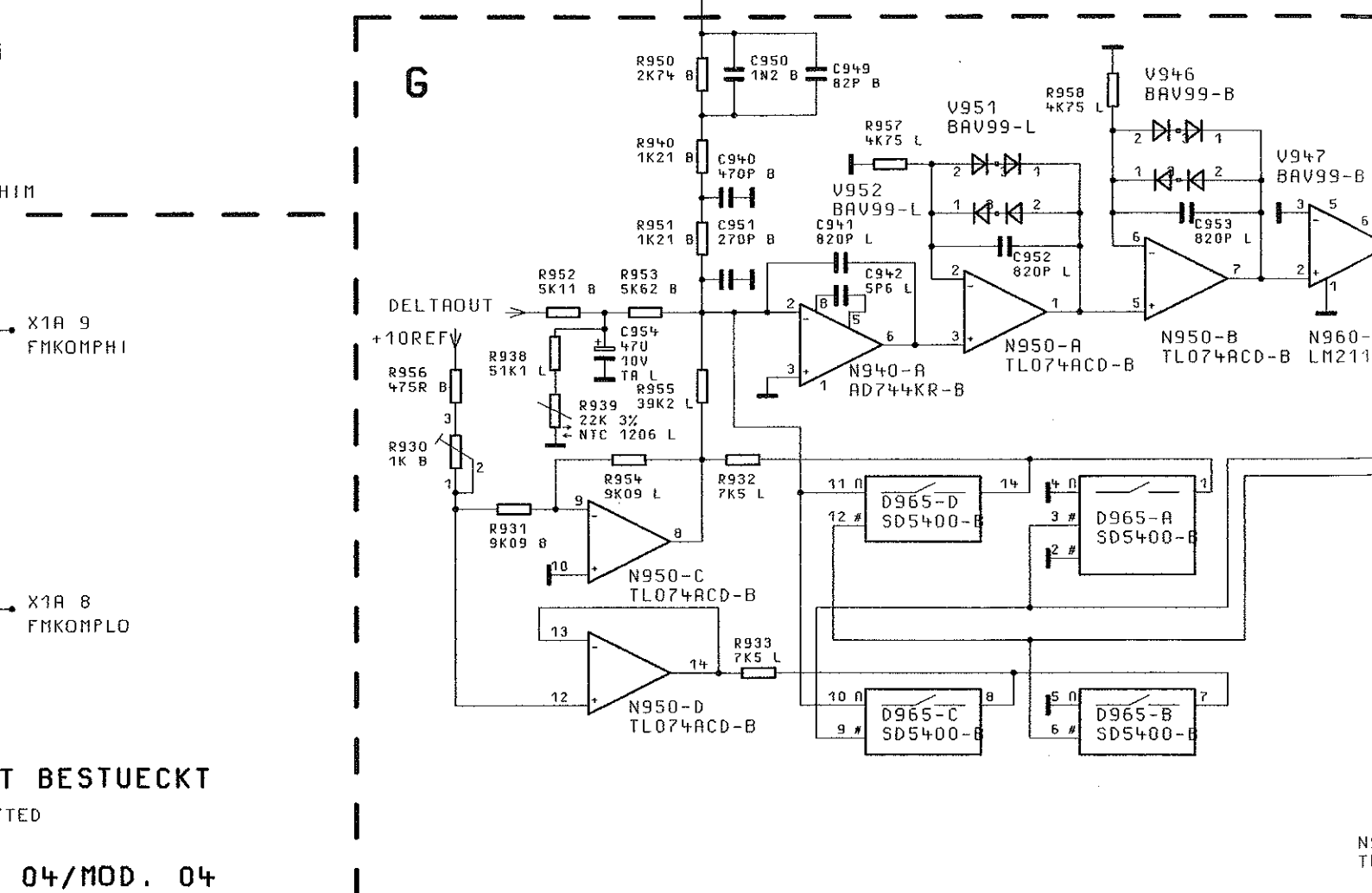
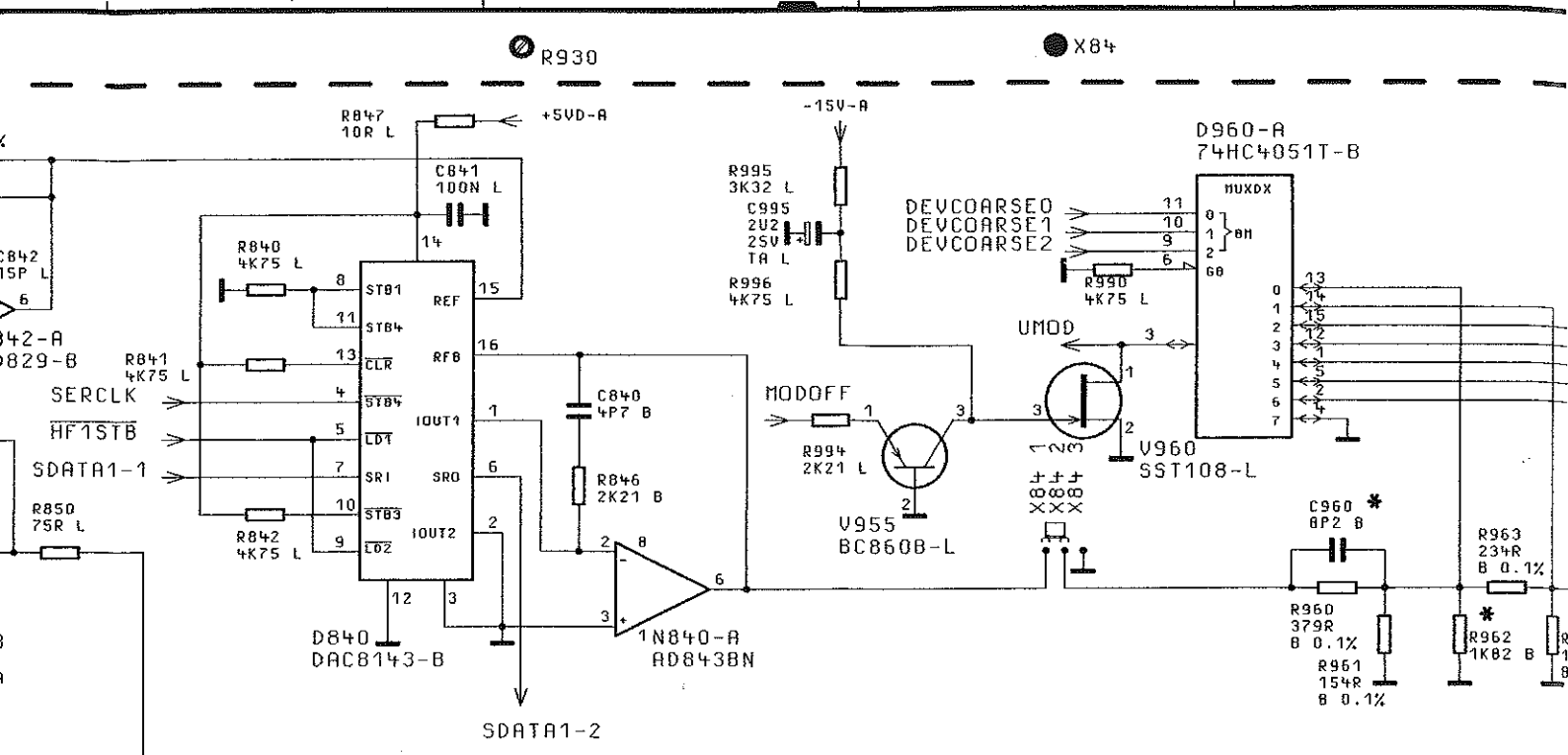

BESTUECKT
 04/MOD. 04

UEBER VARIANTEN,
 WERTE UND
 BAUTEILE SIEHE SA.
 INFORMATION ON MODELS,
 COMPONENTS VALUES AND
 COMPONENTS SEE PARTS LIST.



ACHTUNG: EGB!
 ELEKTROSTATISCH GEFÄHRDETE
 BAUELEMENTE ERFORDERN EINE
 BESONDERE HANDHABUNG.
ATTENTION ESD!
 ELECTROSTATIC SENSITIVE DEVICES
 REQUIRE A SPECIAL HANDLING

04/02	21.02.97	E I	MENP	TAG	NAME
			BEARB.		E I
			GEPR.		
			NGRN		
			PLOTT	21.02.97	
04/01	02.12.96	WH			
ÄNDERUNGS- IND.	DATUM	NAME			
			ROHDE&SCHWARZ		
			ZU GERÄT	SMY	

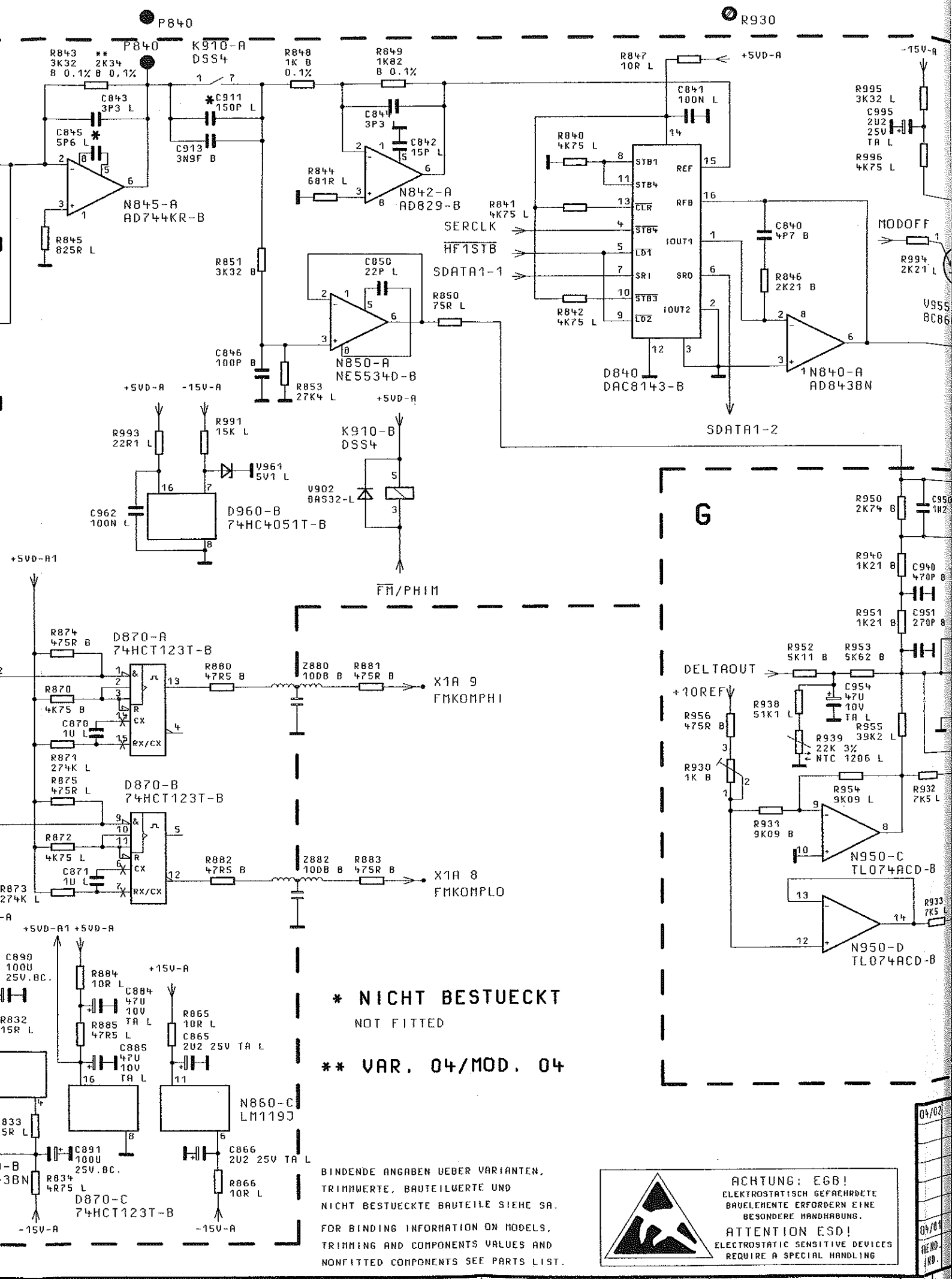

*** NICHT BESTUECKT**
 NOT FITTED
**** VAR. 04/MOD. 04**

BINDENDE ANGABEN UEBER VARIANTEN,
 TRIMMWERTE, BAUTEILWERTE UND
 NICHT BESTUECKTE BAUTEILE SIEHE SA.
 FOR BINDING INFORMATION ON MODELS,
 TRIMMING AND COMPONENTS VALUES AND
 NONFITTED COMPONENTS SEE PARTS LIST.

ACHTUNG: ESB!
 ELEKTROSTATISCH GEFÄHRDETE
 BAUELEMENTE ERFORDERN EINE
 BESONDERE HANDHABUNG.
ATTENTION ESD!
 ELECTROSTATIC SENSITIVE DEVICES
 REQUIRE A SPECIAL HANDLING

04/02
 04/01
 REW.
 INB.

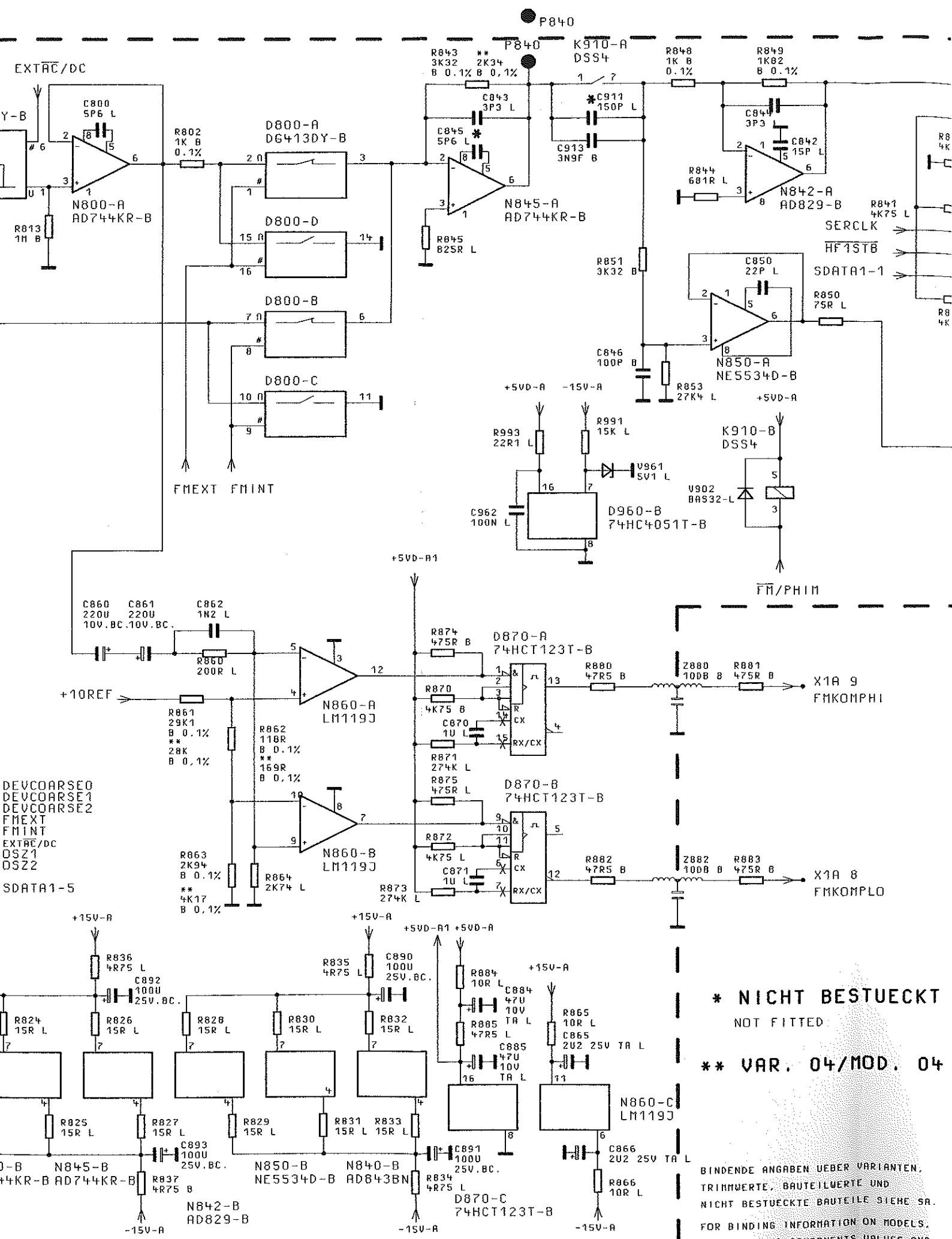

*** NICHT BESTUECKT**
 NOT FITTED
**** VAR. 04/MOD. 04**

BINDENDE ANGABEN UEBER VARIANTEN,
 TRIMMWERTE, BAUTEILWERTE UND
 NICHT BESTUECKTE BAUTEILE SIEHE SA.
 FOR BINDING INFORMATION ON MODELS,
 TRIMMING AND COMPONENTS VALUES AND
 NONFITTED COMPONENTS SEE PARTS LIST.

A

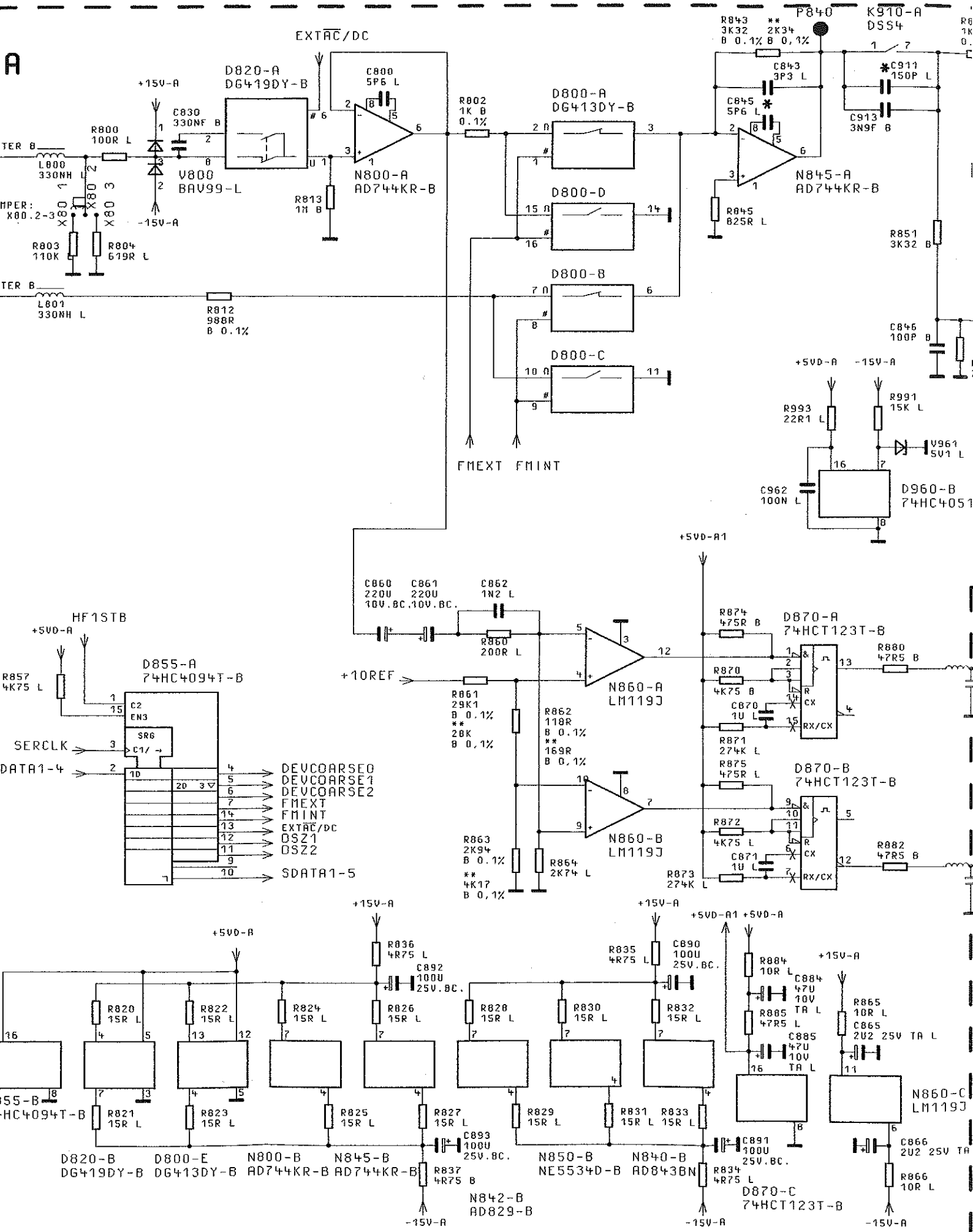

FUER DIESE UNTERLAGE
BEHALTEN WIR UNS ALLE RECHTE VOR

ZEICHN-NR 062.6409.01 S

F
E
D
C
B
A

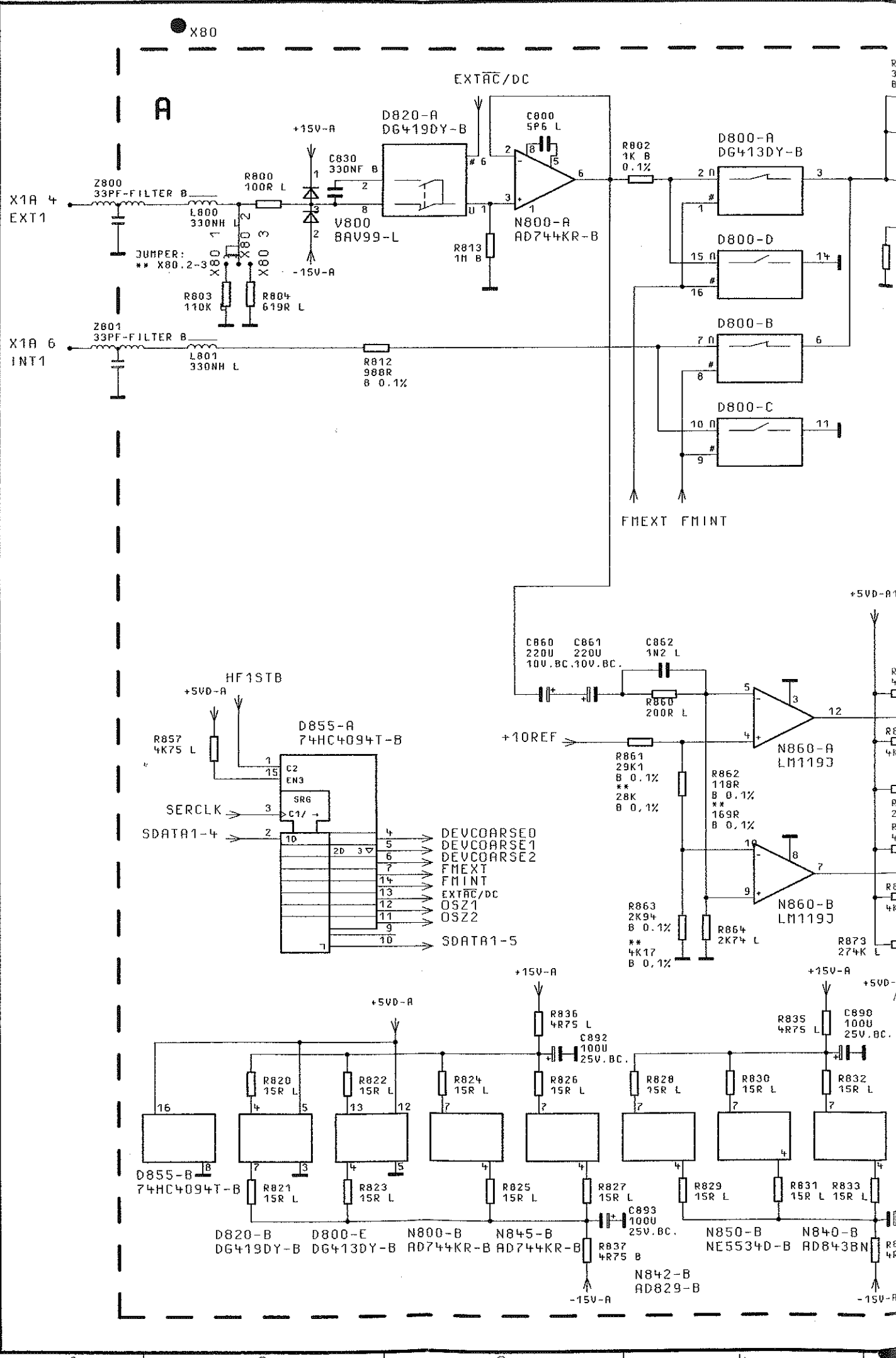

1 2 3 4

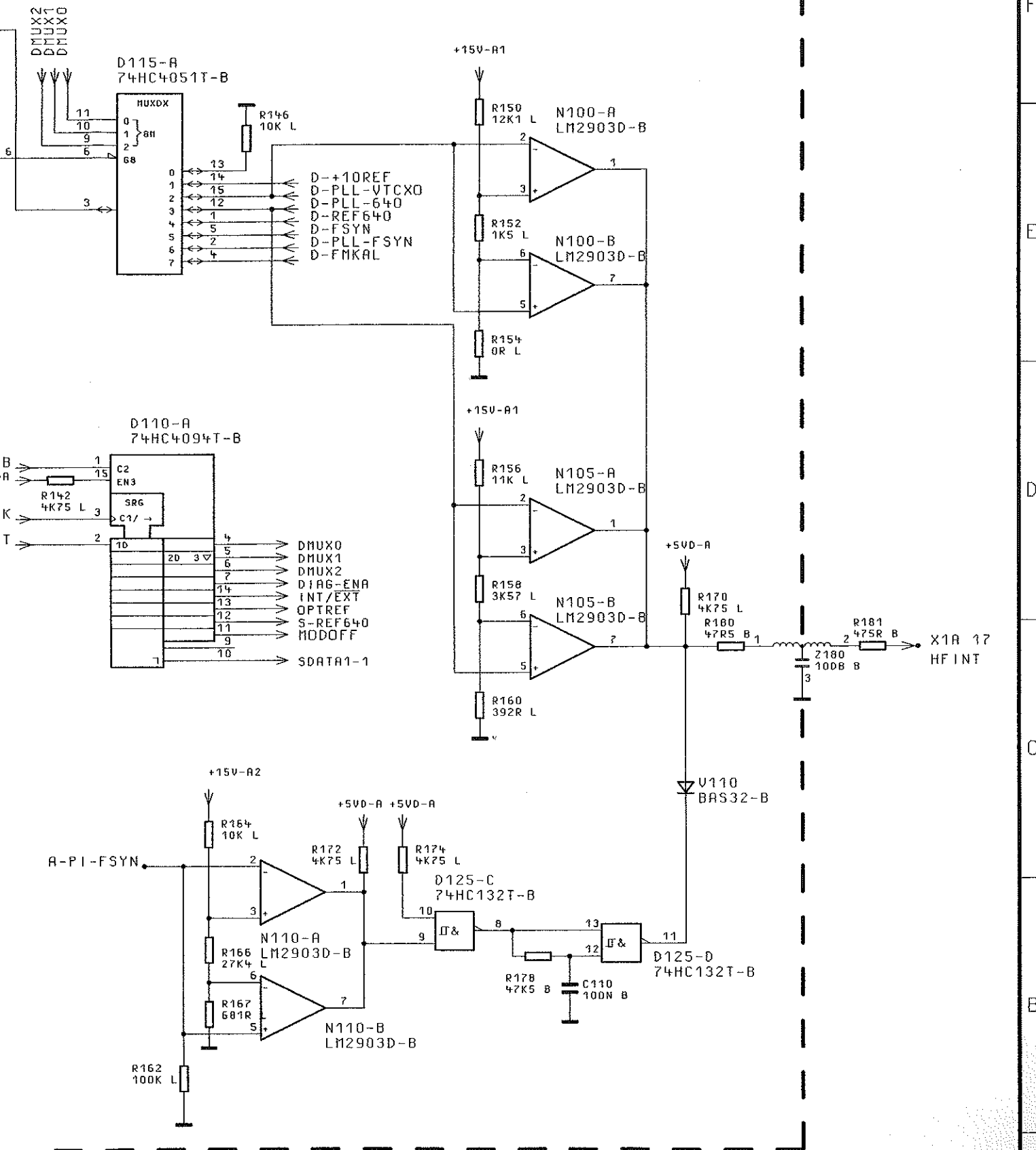

04/02	21.02.97	E I	MENP	TAG	NAME	BEKENNUNG
			BEARB.		E I	SYNTHESIZER SYNTHESIZER
			GEPR.			
			NORM			
			PLOTT	21.02.97		
04/01	02.12.96	WH				ZEICHN.-NR.
REND. IND.	ÄNDERUNGS- MITTEILUNG	DATUM	NAME	ROHDE&SCHWARZ		1062.6409.01S
			ZU GERÄT	SMY	REG. I. V.	1062.5502
					ERSTE Z.	1062.5502

F
E
D
C
B
A

CS

9

10

11

12

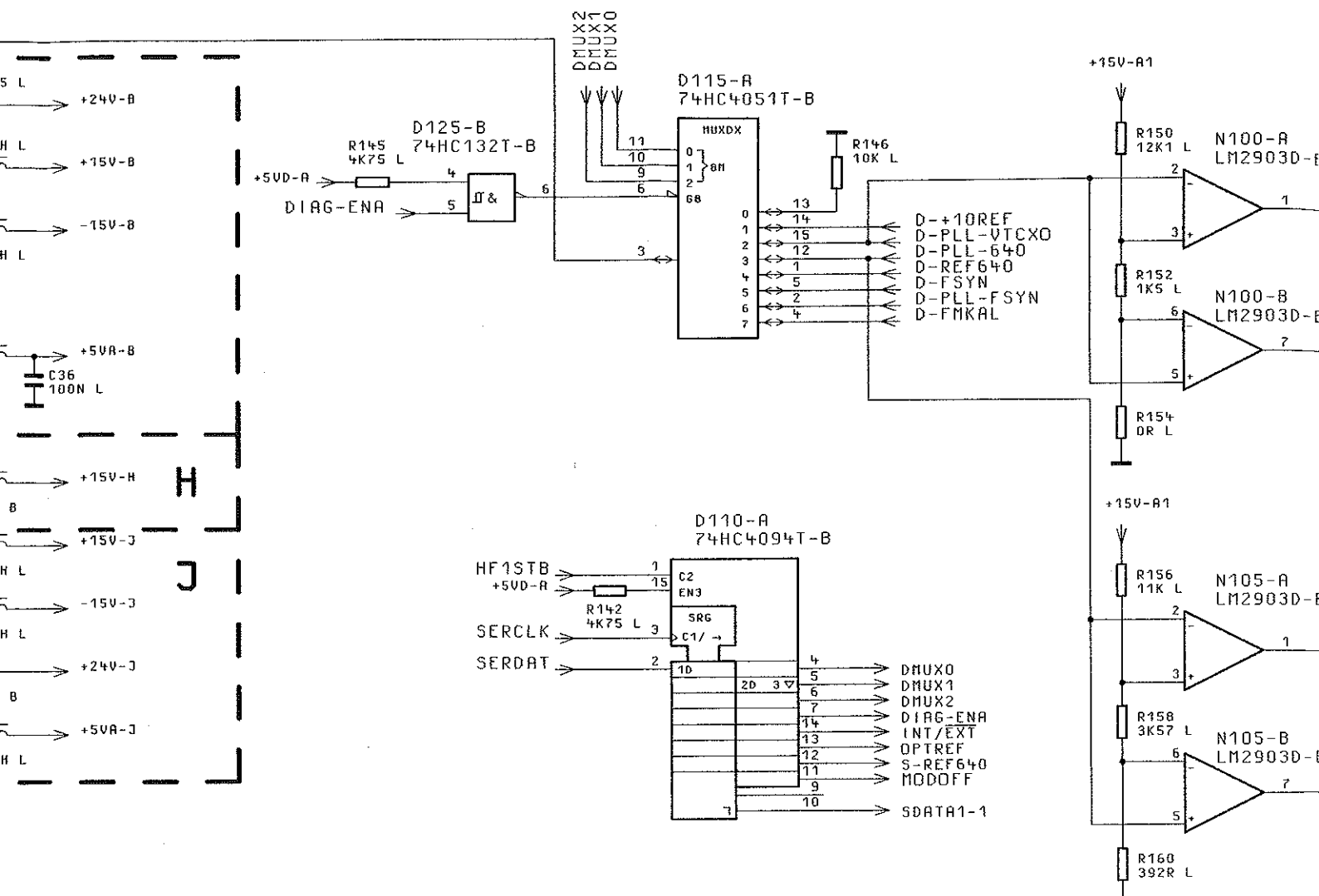

** VAR. 04/MOD. 04

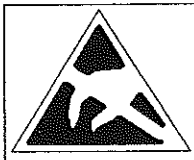

ACHTUNG: EGB!
ELEKTROSTATISCH BEFAHRDETE
BAUELEMENTE ERFORDERN EINE
BESONDERE HANDHABUNG.
ATTENTION ESD!
ELECTROSTATIC SENSITIVE DEVICES
REQUIRE A SPECIAL HANDLING

04/02	21.02.97	E I	MENP	TAG	NAME	BENENNUNG
			BEARB.		E I	SY
			GEPR.			SYN
			NORM			
			PLOTT	21.02.97		
04/01	02.12.96	WH				ZEICHN.-
REND. IND.	BEREICHUNG- MITTEILUNG	DATUM	NAME	 ZU GERÄT SMY		REG. I. V.

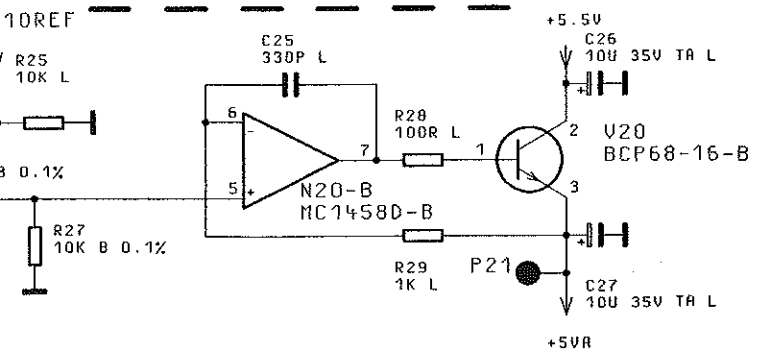
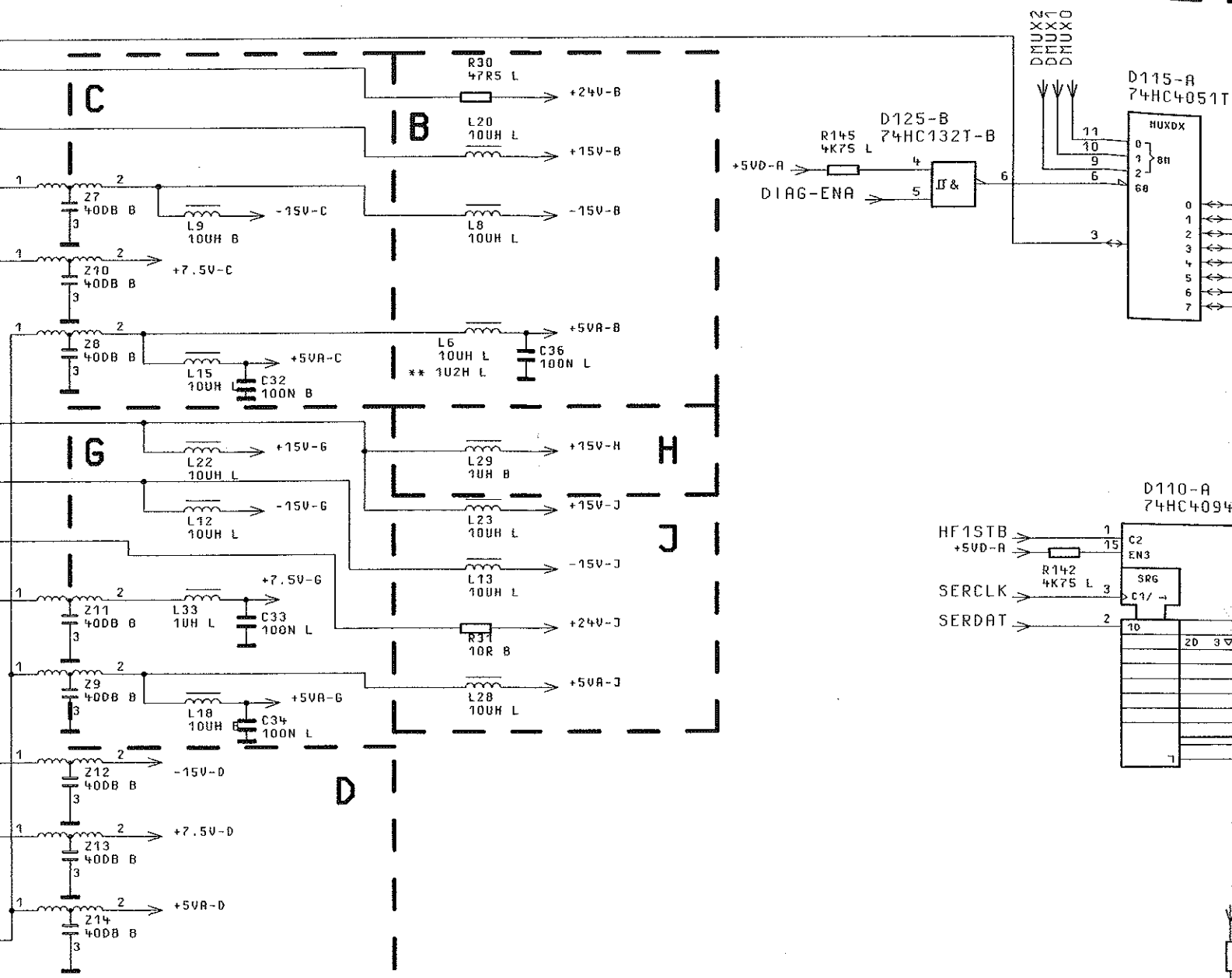

*** NICHT BESTUECKT**
NOT FITTED

**** VAR. 04/MOD. 04**

BINDENDE ANGABEN UEBER VARIANTEN,
TRIMMWERTE, BAUTEILWERTE UND
NICHT BESTUECKTE BAUTEILE SIEHE SA.
FOR BINDING INFORMATION ON MODELS,
TRIMMING AND COMPONENTS VALUES AND
NONFITTED COMPONENTS SEE PARTS LIST.

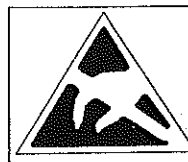

ACHTUNG: EGB!
ELEKTROSTATISCH GEFÄHRDETE
BAUELEMENTE ERFORDERN EINE
BESONDERE HANDHABUNG.
ATTENTION ESD!
ELECTROSTATIC SENSITIVE DEVICES
REQUIRE A SPECIAL HANDLING

04/02	
04/03	
REND. IND.	ÄNDERUNGS MITTEILUNG

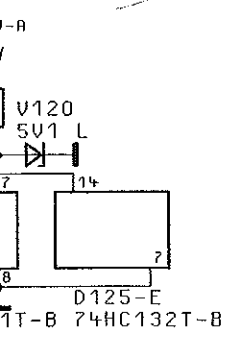

R20

P20

P21

RCLK

RDAT

1STB

2STB

5VD-A

L

+V

5V

5V

5V

5V-A

B

00-C

3

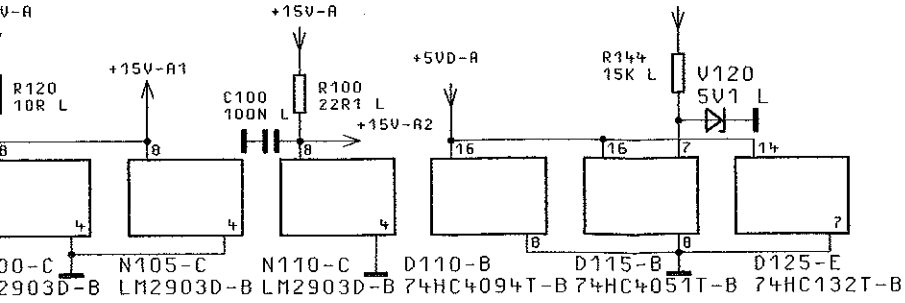
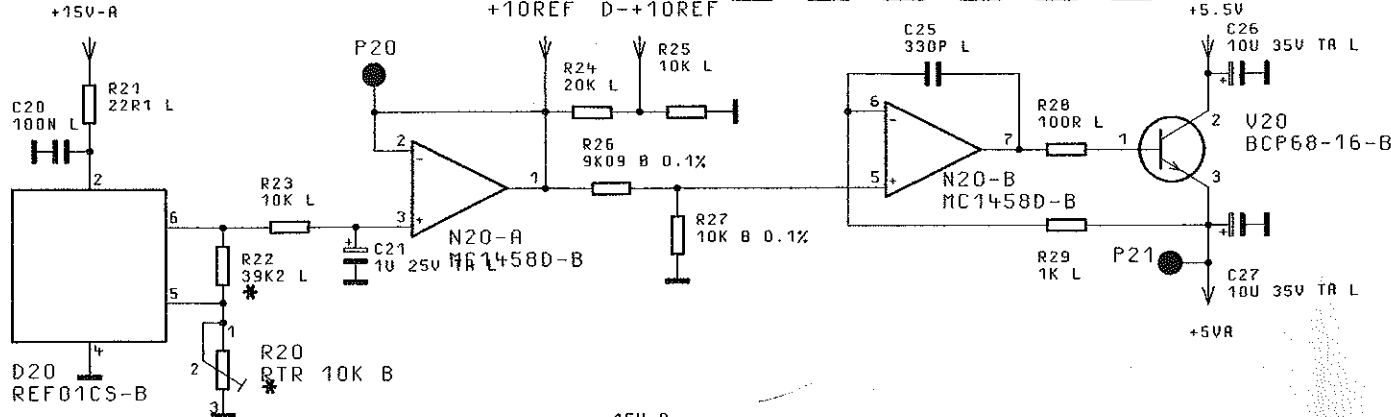
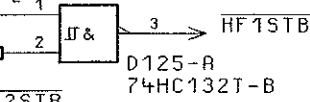
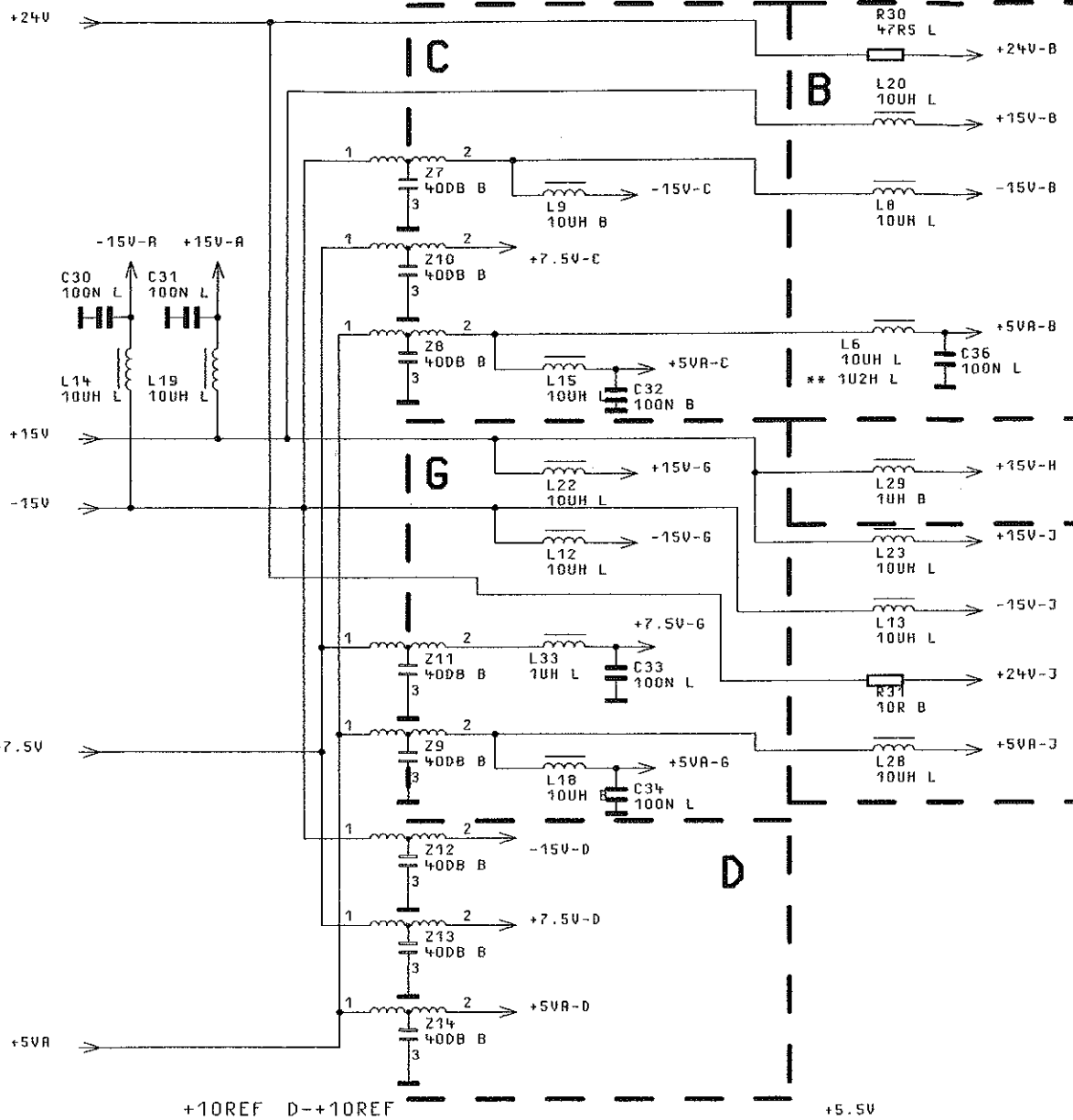

BINDENDE ANGABEN UEBER VARIANTEN, TRIMMWERTE, BAUTEILWERTE UND NICHT BESTUECKTE BAUTEILE SIEHE SA.
 FOR BINDING INFORMATION ON MODELS, TRIMMING AND COMPONENTS VALUES AND NONFITTED COMPONENTS SEE PARTS LIST.

* NIC
 NOT
 ** U



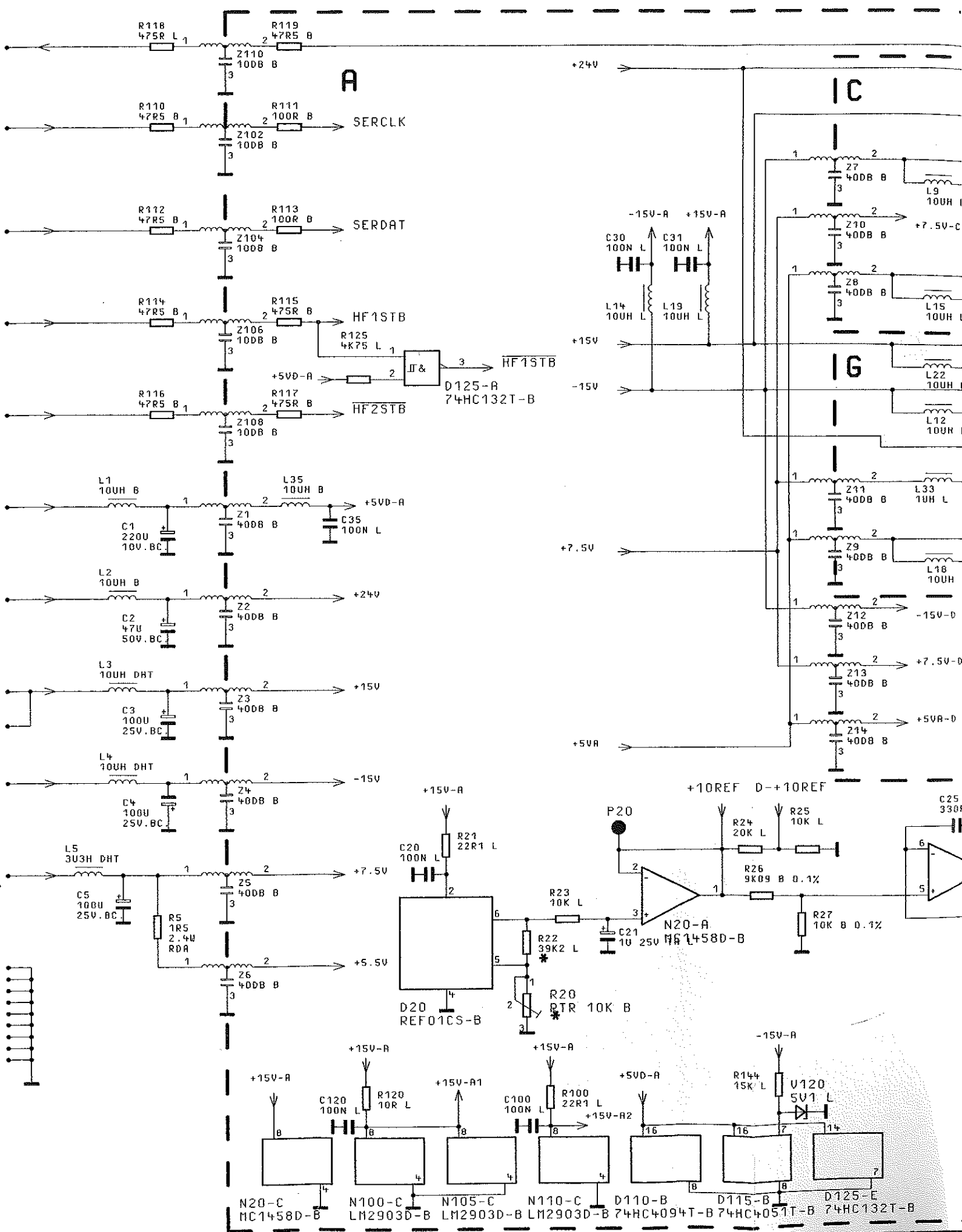

FÜR DIESE UNTERLAGE
BEHALTEN WIR UNS ALLE RECHTE VOR

ZEICHN.-NR. 1062.6409.01 S

R20 P20

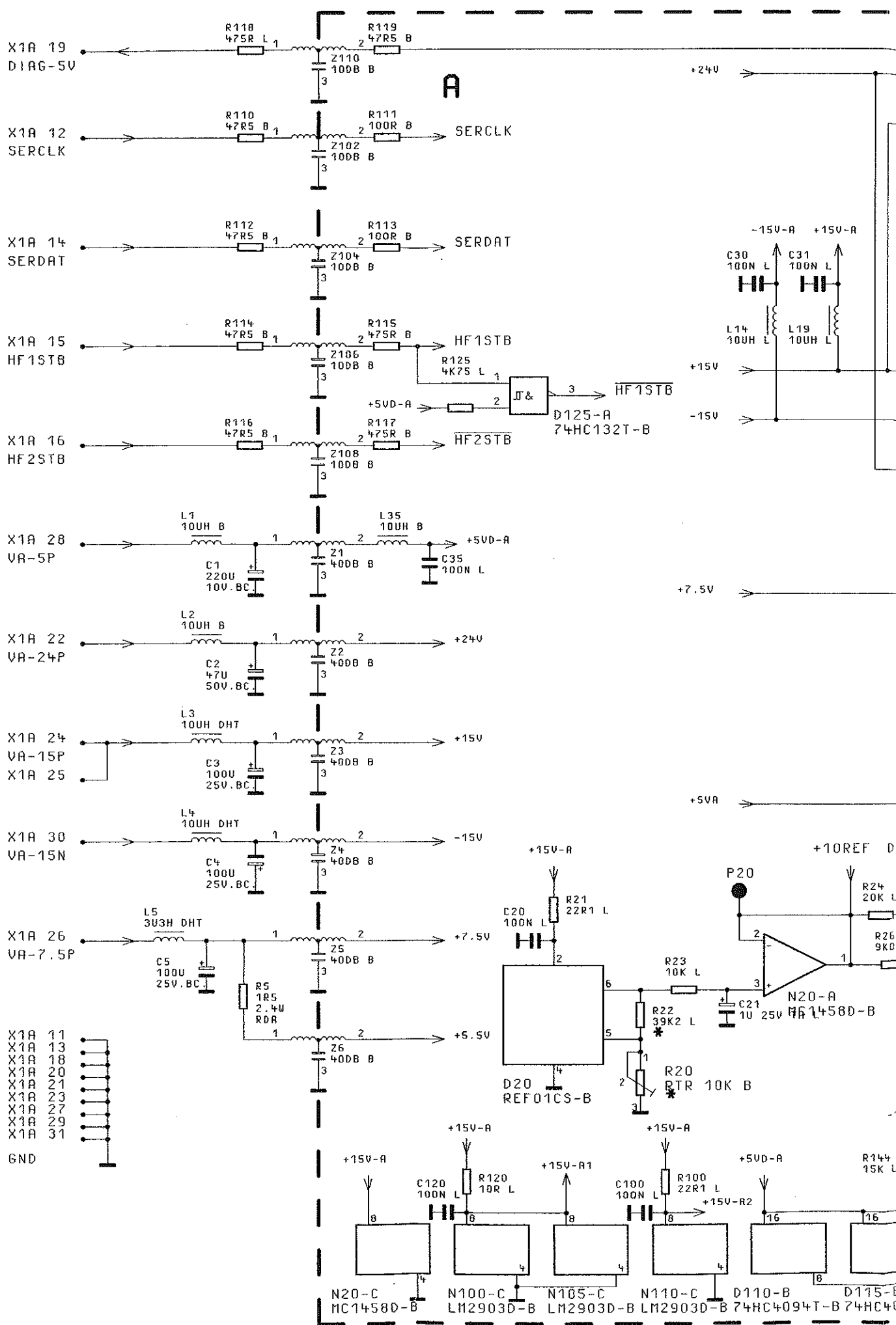

1 2 3 4

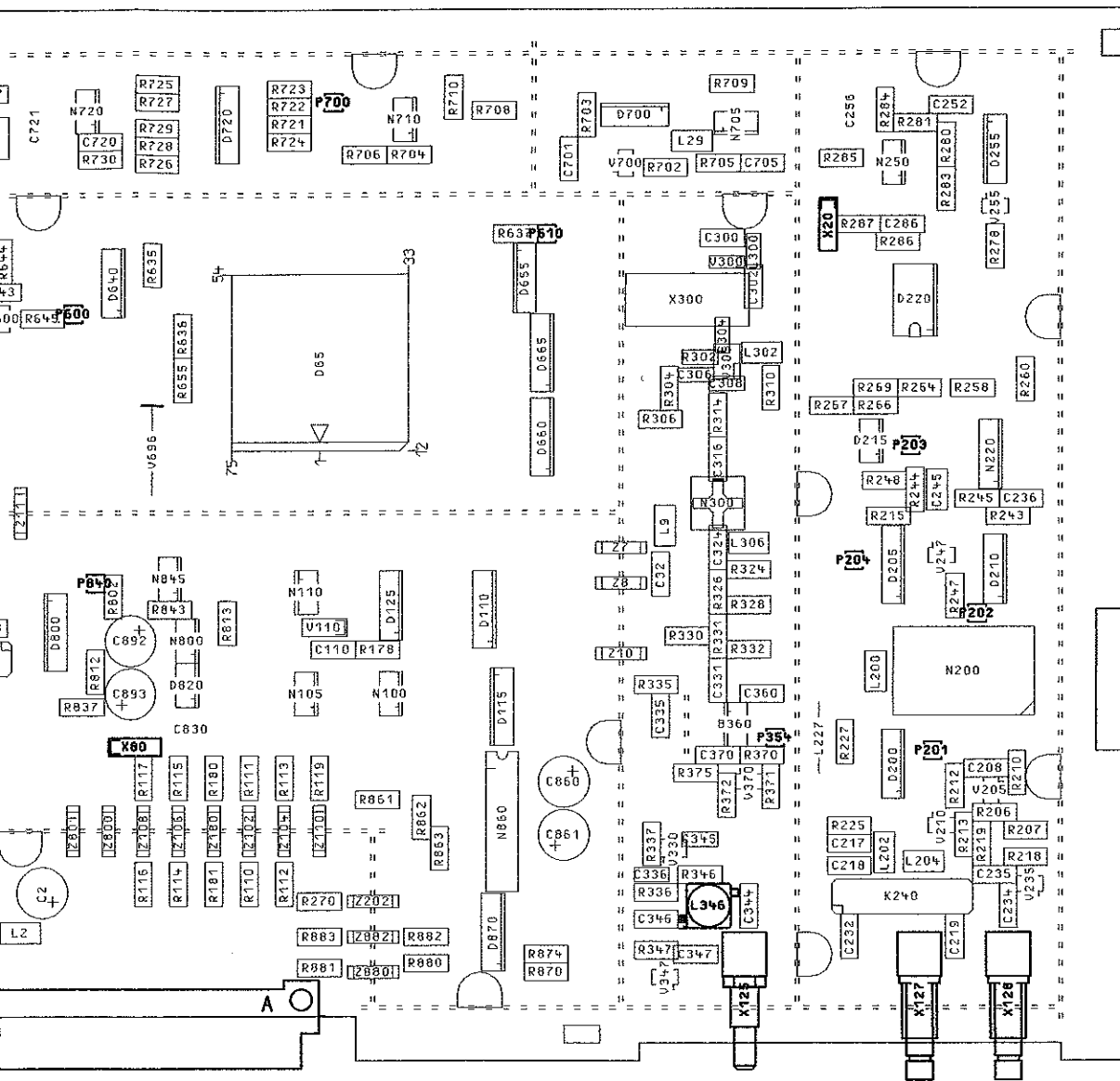

04/02	21.02.97	E I	MENP	TRG	HANE	BENENNUNG	Z
			BERB.		E I	SYNTHESIZER SYNTHESIZER	
			GEPR.				
			NORR				
			PLOTT	21.02.97			
02/02						ZEICHN.-NR.	1+
END. IND.	RENDERUNGS- MITTEILUNG	DATUR	NAME			1062.6409.01	EE
			ZF GERÄT	SHY	RES. I.V.	1062.5502	1062.5502

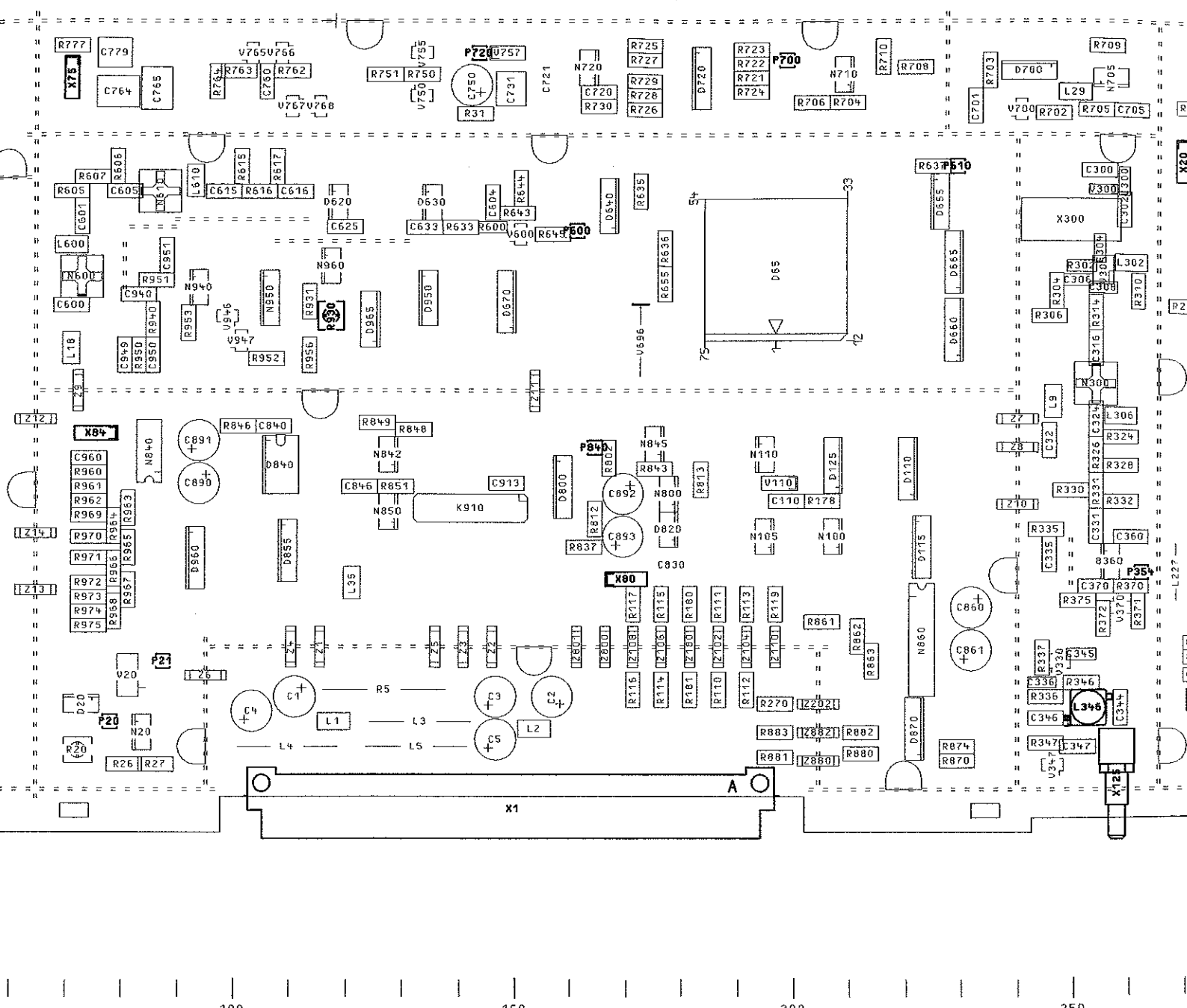

ANGABEN ÜBER VARIANTEN.
 WERTE, BRUTEILWERTE UND
 MIT BESTÜCKTE BRUTEILE SIEHE SA.

BINDING INFORMATION ON MODELS,
 DIMENSIONS AND COMPONENTS VALUES AND
 FITTED COMPONENTS SEE PARTS LIST.

04/02	21.02.97	E. I.	MEMP	TAG
			BEARB.	
			GEPR.	
			NORM	
			PLOT11	21.02.
02/02				
ACHD.	RENDERUNGS-	DATUM	NAME	ROHDE & S
IND.	MITTEILUNG		ZU GEBEN	

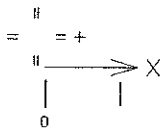
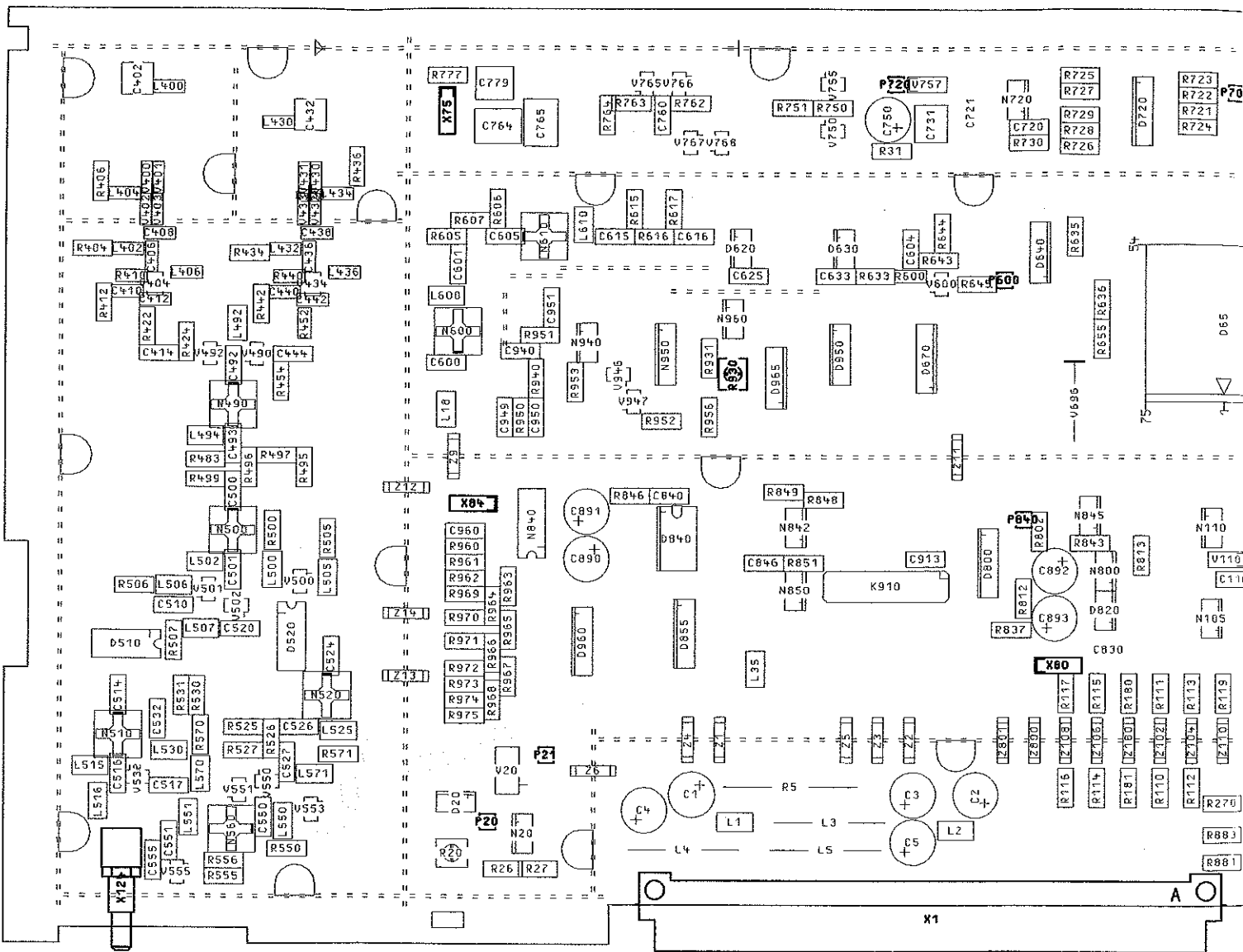

TE B



ACHTUNG: ESD!
ELEKTROSTATISCH GEFÄHRDARTE
BAUELEMENTE ERFORDERN EINE
BESONDERE NÄHRHANDLUNG.
ATTENTION ESD!
ELECTROSTATIC SENSITIVE DEVICES
REQUIRE A SPECIAL HANDLING

BINDENDE ANGABEN ÜBER VARIANTEN,
TRIMMWERTE, BAUTEILWERTE UND
NICHT BESTÜCKTE BAUTEILE SIEHE SA.

FOR BINDING INFORMATION ON MODELS,
TRIMMING AND COMPONENTS VALUES AND
NONFITTED COMPONENTS SEE PARTS LIST.

FÜR DIESE ZEICHNUNG BEHALTEN UNS ALLE RECHTE VOR.
 DIESE ZEICHNUNG IST EIN RECHNERAUSDRUCK, ÄNDERUNGEN KÖNNEN NUR DURCH ÄNDERN DES DATENSATZES ERFOLGEN

H

G

U

F

E

D

C

B

A

150

100

50

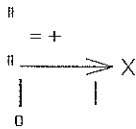
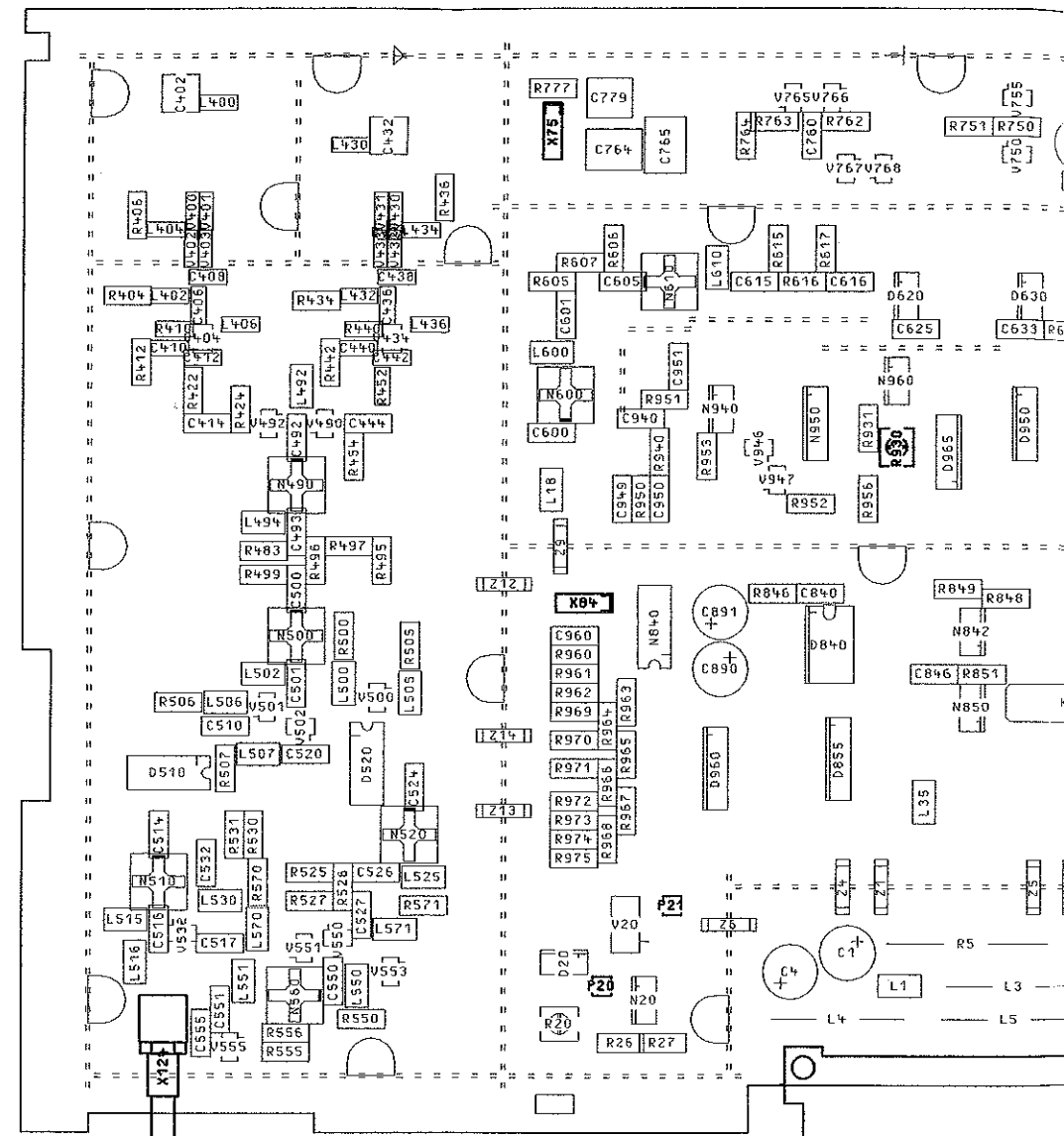

50

100

DARSTELLUNG SEITE B
VIEW ON SIDE B



ACHTUNG: EGB!
 ELEKTROSTATISCH GEFÄHRDENE
 BAUELEMENTE ERFORDERN EINE
 BESONDERE HANDLUNG.
ATTENTION ESD!
 ELECTROSTATIC SENSITIVE DEVICES
 REQUIRE A SPECIAL HANDLING

BINDENDE ANGABEN ÜBER VARIANTEN,
 TRIMMWERTE, BAUTEILWERTE UND
 NICHT BESTÜCKTE BAUTEILE SIEHE SR.

FOR BINDING INFORMATION ON MODELS,
 TRIMMING AND COMPONENTS VALUES AND
 NONFITTED COMPONENTS SEE PARTS LIST.

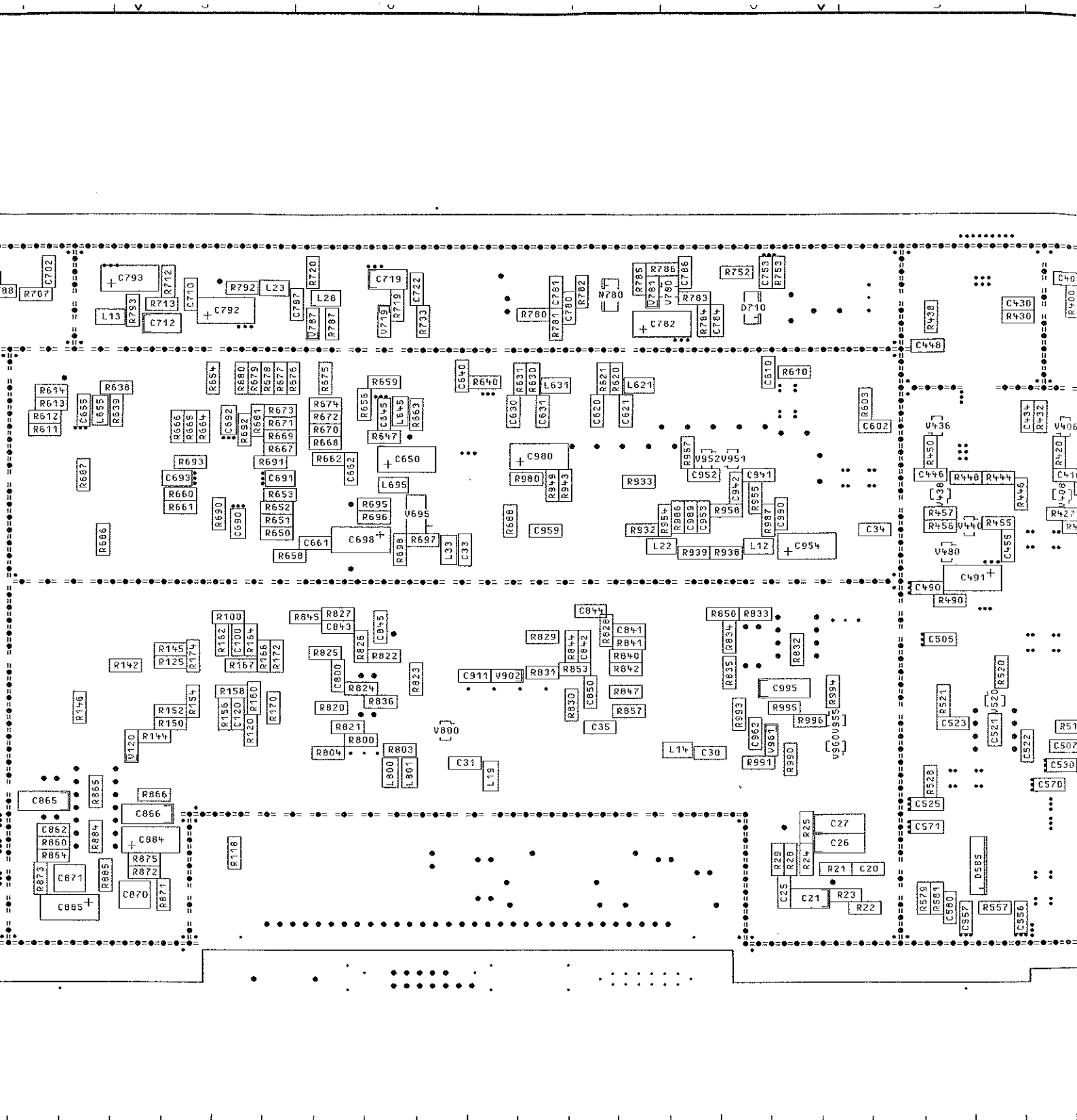

200 150 100 50

BINDERANGABEN ÜBER VARIANTEN,
 TRAHWERTE, BAUTEILWERTE UND
 NICHT BESTÜCKTE BAUTEILE SIEHE SR.

FOR BINDING INFORMATION ON MODELS,
 TRAHING AND COMPONENTS VALUES AND
 NONFITTED COMPONENTS SEE PARTS LIST.

04/02		21.02.97	E I	MEMP
				BEARB.
				GEPR.
				NORN
				PLOTT 21
02/02	REND.	ÄNDERUNGS-	DATUM	NAMEN
	IND.	MITTEILUNG		
 28 SECRETS				

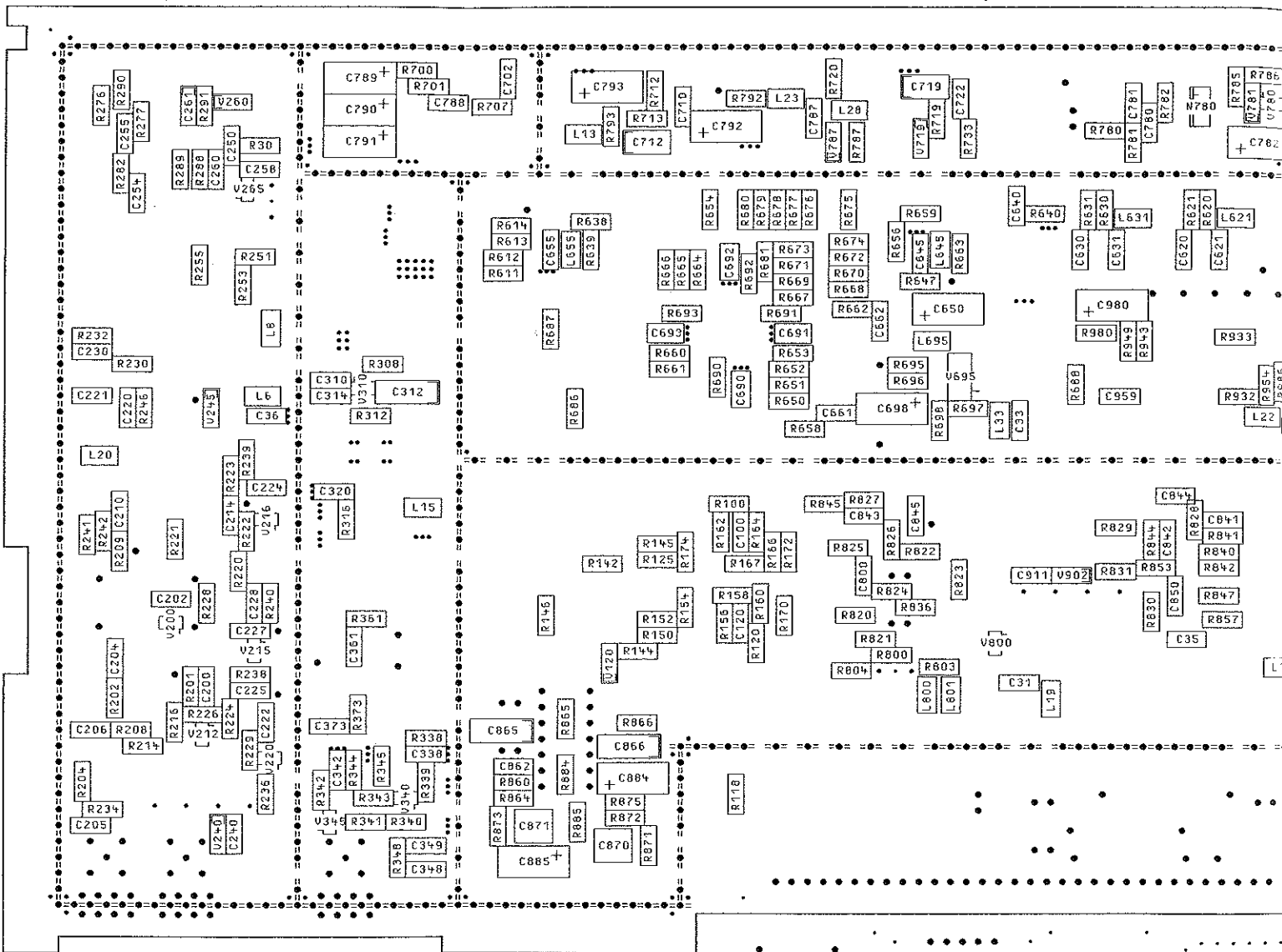

ACHTUNG: EGB!
ELEKTROSTATISCH GEFÄHRDETE
BAUELEMENTE ERFORDERN EINE
BESONDERE HANDLUNG.
ATTENTION ESD!
ELECTROSTATIC SENSITIVE DEVICES
REQUIRE A SPECIAL HANDLING

BINDENDE ANGABEN UEBER VARIANTEN,
TRIMMWERTE, BAUTEILWERTE UND
NICHT BESTUECKTE BAUTEILE SIEHE SR.

FOR BINDING INFORMATION ON MODELS,
TRIMMING AND COMPONENTS VALUES AND
NONFITTED COMPONENTS SEE PARTS LIST.

FÜR DIESE ZEICHNUNG BEHALTEN SICH ALLE RECHTE VOR.
 DIESE ZEICHNUNG IST EIN RECHNERDRUCK. ÄNDERUNGEN KÖNNEN NUR DURCH ERNEUTEN DES DATENSATZES ERFOLGEN

H
 G
 U
 F
 F
 D
 C
 B
 A

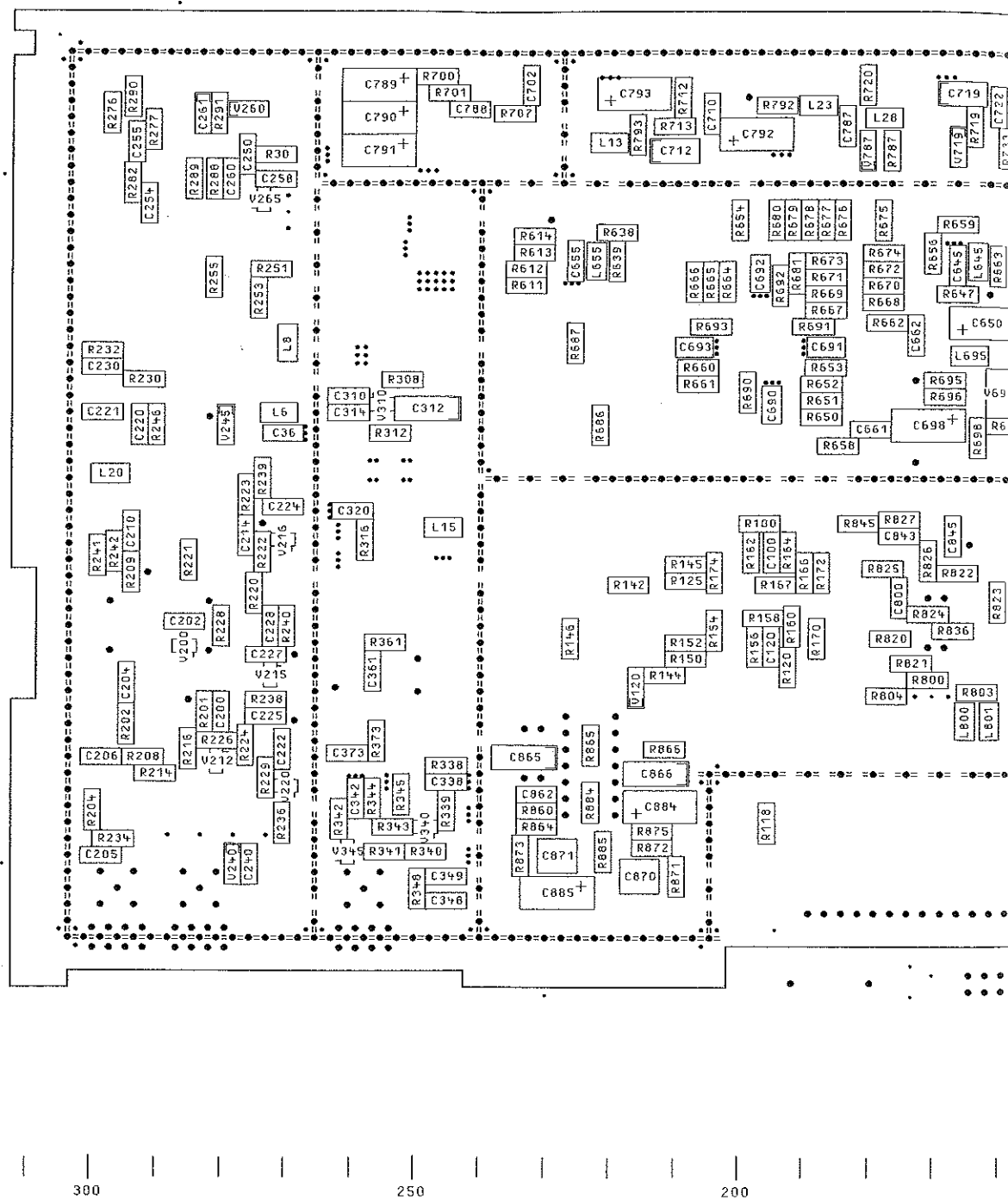

DARSTELLUNG SEITE A
 VIEW ON SIDE A



ACHTUNG: ESD!
 ELEKTROSTATISCH GEFÄHRDETE
 BAUELEMENTE ERFORDERN EINE
 BESONDERE HANDLUNG.
ATTENTION ESD!
 ELECTROSTATIC SENSITIVE DEVICES
 REQUIRE A SPECIAL HANDLING

BINDENDE ANGABEN ÜBER VARIANTEN,
 TRIMMWERTE, BAUTEILWERTE UND
 NICHT BESTÜCKTE BAUTEILE SIEHE SA.
 FOR BINDING INFORMATION ON MODELS,
 TRIMMING AND COMPONENTS VALUES AND
 NONFITTED COMPONENTS SEE PARTS LIST.

FUER DIESE ZEICHNUNG BEHALTEN SICH ALLE RECHTE VOR.
 DIESE ZEICHNUNG IST EIN RECHNERAUSDRUCK, VERÄNDERUNGEN KÖNNEN NUR DURCH ÄNDERN DES DATENSATZES ERFOLGEN

DARSTELLUNG SEITE A
 VIEW ON SIDE A



ACHTUNG: EGB!
 ELEKTROSTATISCH GEFÄHRLICHE
 BAUELEMENTE ERFORDERN EINE
 BESONDERE HANDhabUNG.
ATTENTION ESD!
 ELECTROSTATIC SENSITIVE DEVICES
 REQUIRE A SPECIAL HANDLING

BINDENDE ANGABEN ÜBER VARIANTEN,
 TRIMMWERTE, BAUTEILWERTE UND
 NICHT BESTÜCKTE BAUTEILE SIEHE SA.

FOR BINDING INFORMATION ON MODELS,
 TRIMMING AND COMPONENTS VALUES AND
 NONFITTED COMPONENTS SEE PARTS LIST.

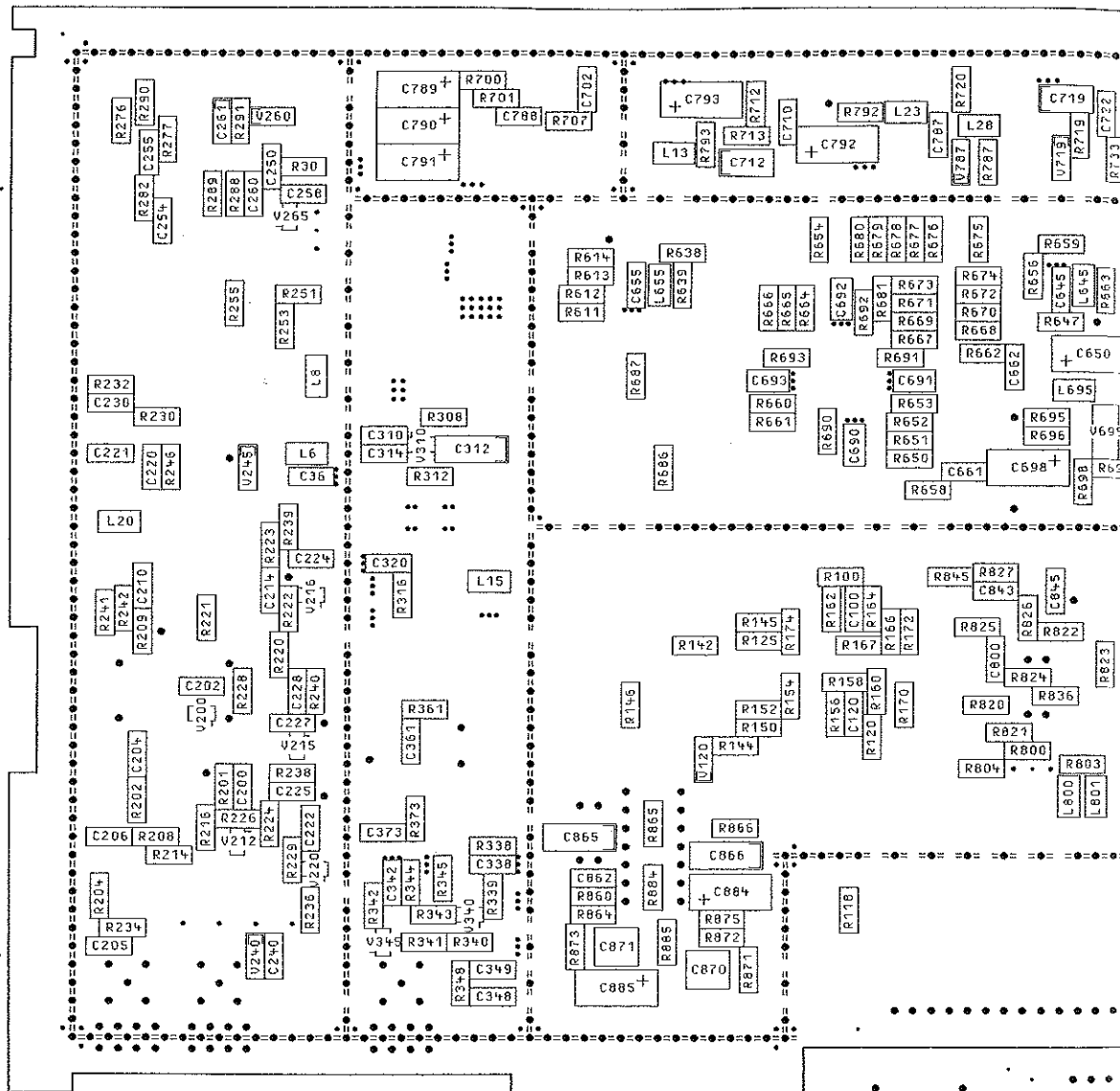

300

250

200



ROHDE & SCHWARZ

SERVICEUNTERLAGEN

Ausgangsteil 1.04 GHz

1062.6209.01

Inhaltsverzeichnis

7 Prüfen und Instandsetzen der Baugruppe.....	5
7.1 Funktionsbeschreibung.....	5
7.1.1 RF-Signalverarbeitung.....	5
7.1.2 Mischer mit LO-, RF- und ZF-Filtern.....	6
7.1.3 Ausgangsverstärker.....	6
7.1.4 AM-Signalzweig und RF-Pegel-Sollwert.....	6
7.1.5 RF-Pegelregelung.....	6
7.1.6 serielle Schnittstelle.....	7
7.1.7 Schaltung zur Diagnoseauswahl.....	7
7.2 Meßgeräte und Hilfsmittel.....	7
7.3 Fehlersuche.....	7
7.3.1 Fehler nur im Bereich $f_{RF} < 10$ MHz.....	7
7.3.2 Fehler nur im Bereich $f_{RF} < 65$ MHz.....	8
7.3.3 Fehler im Bereich $5 \text{ kHz} \leq f_{RF} \leq 1040$ MHz.....	8
7.3.4 Spektrale Reinheit, $\Delta f < 10$ MHz vom Träger.....	9
7.4 Prüfen und Abgleich.....	9
7.4.1 Prüfen der Datenübertragung.....	9
7.4.2 Prüfen der Ausgangsspannung des Regelverstärkers.....	9
7.4.3 Prüfen der LEVEL PRESET-Steuerspannung.....	10
7.4.4 Prüfen der Arbeitspunkte der Verstärkerstufen.....	10
7.4.5 Prüfen der Ansteuerung der Filterbank.....	10
7.4.6 Prüfen des RF-Pegels nach der Filterbank.....	11
7.4.7 Abgleich der ZF-Verstärkung.....	11
7.4.8 Abgleich der ZF-Detektor-Linearität.....	11
7.4.9 Abgleich der Detektor-Linearität am Ausgang FOPU.....	12
7.4.10 Abgleich des AM-Modulationsgrades.....	12
7.5 Zerlegung und Zusammenbau.....	12
7.6 Endprüfung.....	13
7.6.1 Prüfen des maximalen Ausgangspegels.....	13
7.6.2 Prüfen des Oberwellenabstandes.....	13
7.6.3 Prüfen des Nebenwellenabstandes.....	14
7.7 Externe Schnittstellen.....	14

Schaltteilliste
Koordinatenliste
Stromlauf
Bestückungsplan

Bei Geräten ohne Option SMY-B40 hat die Baugruppe die Variante VAR02.

Bei Geräten mit Option SMY-B40 hat die Baugruppe die Variante VAR03.

7.1 Funktionsbeschreibung

Das Ausgangsteil 1.04 GHz erhält über den Eingang FSYN von der Baugruppe Synthese das RF-Signal (6 dBm ... 12 dBm) im Frequenzbereich $65 \text{ MHz} \leq f_{\text{SYN}} \leq 1040 \text{ MHz}$. Dieses RF-Signal wird über einen Amplitudenmodulator und ein Amplitudenstellglied auf schaltbare Tiefpaßfilter gegeben. Im Signalzweig wird durch Umschalter der Ausgangsfrequenzbereich $5 \text{ kHz} \leq f_{\text{RF}} \leq 65 \text{ MHz}$ durch Abmischen mit einem 640 MHz-LO realisiert.

Die Baugruppe enthält folgende Funktionseinheiten:

- Einen AM-Modulator zur Pegelregelung und Amplitudenmodulation,
- einen AM-Modulator zur Pegelvoreinstellung (LEVEL PRESET),
- schaltbare Tiefpässe zur Unterdrückung von Harmonischen,
- einen Mischer mit LO-, RF- und ZF-Filtern,
- einen Pegeldetektor im RF-Zweig vor dem Mischer,
- einen Ausgangsverstärker,
- einen Pegeldetektor am Ausgang FOPU,
- einen Signalzweig zur Einstellung des RF-Pegelsollwertes und des Amplitudenmodulationsgrades,
- die RF-Pegelregelung,
- eine serielle Schnittstelle und
- eine Schaltung zur Diagnoseauswahl.

Im weiteren Text enthaltene Pegelangaben gelten für einen Geräteausgangspegel von +13 dBm (+19 dBm mit Option SMY-B40).

7.1.1 RF-Signalverarbeitung

Dem Eingang X224 FSYN ist ein Dämpfungsglied zur Temperaturkompensation nachgeschaltet. Anschließend folgt der AM MODULATOR.

Er ist das Stellglied der Pegelregelung im Bereich $f_{\text{RF}} \leq 1.04 \text{ GHz}$. Das RF-Signal wird durch RF AMPLIFIER 1 und RF AMPLIFIER 2 verstärkt und auf den PIN-Modulator LEVEL PRESET gegeben. Dieser Modulator wird durch gespeicherte Kalibrierdaten mittels D/A-Wandler so eingestellt, daß das Stellglied der Pegelregelung in einem optimalen Arbeitspunkt betrieben werden kann (vergl. Bedienhandbuch "Kalibrierung LEVEL PRESET").

Das RF-Signal wird durch den RF AMPLIFIER 3 verstärkt und auf schaltbare Tiefpässe HARMONIC FILTERS gegeben. Diese werden abhängig von der Eingangsfrequenz an X224 FSYN durch den Rechner eingeschaltet. Die Tiefpässe TP0 bis TP3 sind wie die Tiefpässe TP4 bis TP8 in Kette geschaltet. Filter in der Kette mit höherer Grenzfrequenz als der Grenzfrequenz des gewählten Tiefpasses bleiben eingeschaltet.

Im "Normalbetrieb" wird das RF-Signal über den PIN-Schalter SWITCHD (OFF) und den GaAs-Umschalter SWITCHB (OFF) auf den Ausgangsverstärker gegeben. Im "Mischerbetrieb" wird das RF-Signal über PIN-Schalter SWITCHD (ON) und den RF AMPLIFIER 4 auf den Detektor vor dem Mischer geschaltet.

7.1.2 Mischer mit LO-, RF- und ZF-Filtern

Das RF-Signal vom Detektor vor dem Mischer wird über den RF-Tiefpaß und ein Dämpfungsglied zur Pegelanpassung auf den RF-Eingang des Mixers geschaltet (Pegel ca. -5 ... -10 dBm). Das Signal von REF640 gelangt über einen Tiefpaß auf den LO-Eingang des Mixers. Über den ZF-Verstärker und den ZF-Tiefpaß wird das ZF-Signal auf den RF-Schalter SWITCHB (ON) vor dem Ausgangsverstärker geschaltet ($5 \text{ kHz} \leq f_{ZF} < 65 \text{ MHz}$, Pegel ca. 0 dBm).

7.1.3 Ausgangsverstärker

Der dreistufige lineare Breitbandverstärker verstärkt das Eingangssignal um ca. 19 dB. Die Kollektorströme der Stufen werden geregelt.

7.1.4 AM-Signalzweig und RF-Pegel-Sollwert

Das Signal der Leitung AMMOD wird auf den D/A-Wandler zur Modulationsgradeinstellung gegeben und gelangt auf den D/A-Wandler RFLEV zur RF-Pegeleinstellung.

7.1.5 RF-Pegelregelung

Bei Geräten ohne Option SMY-B40 wird der Pegeldetektor am Ausgang X226 FOPU bei Gerätefrequenzen $f_{RF} \geq 10 \text{ MHz}$ verwendet. Der RF-Pegel an der Diode beträgt ca. +19 dBm. Die Linearisierungsschaltung ermöglicht einen Dynamikbereich von ca. 30 dB bei guter Linearität (wichtig für geringen AM-Klirrfaktor).

Bei Geräten mit Option SMY-B40 wird für die Pegelregelung bei Gerätefrequenzen $\geq 10 \text{ MHz}$ der Detektor auf der Option SMY-B40 verwendet. Dessen Ausgangsspannung gelangt über das Kabel W125 zum Motherboard und von dort auf den Eingang X2.A5 DETEXT dieser Baugruppe.

Der Pegeldetektor im RF-Zweig vor dem Mischer wird bei Gerätefrequenzen $f_{RF} < 10 \text{ MHz}$ anstelle des Detektors am Ausgang X226 FOPU verwendet. Der RF-Pegel an der Diode beträgt ca. +15 dBm.

Die Pegelregelung erfolgt durch den PI-Regler N235. Der Führungswert wird vom D/A-Wandler RFLEV geliefert und mit dem Istwert von einem der drei Detektoren (VDET, DETEXT oder VDETMIX) je nach Frequenzbereich verglichen. Die Ausgangsspannung des PI-Reglers regelt den AM-Modulator nach.

Die 3dB-Bandbreite der Regelschleife kann durch AMSLOW von ca. 300 kHz auf ca. 50 kHz reduziert werden (siehe Spezialfunktion 13).

Das Aktivieren von KLEMM-N durch den Prozessor steuert den AM-Modulator auf maximale Dämpfung, dies wird z.B. bei Frequenzwechsellern zur Vermeidung von Pegelspikes verwendet.

7.1.6 serielle Schnittstelle

Die ankommenden Daten werden in die Schieberegister und die D/A-Wandler LEVEL PRESET, RFLEV und AM getaktet.

7.1.7 Schaltung zur Diagnoseauswahl

Über den Diagnosemultiplexer kann eine von 8 Gleichspannungen auf die Diagnoseleitung gelegt werden. Der Spannungswert kann im Gerätedisplay angezeigt werden.

Spezialfunktion	Soll-Spannungsbereich	Hinweis
101	0.00 V \pm 10 mV	Referenz 10 kOhm nach Masse
102	0.00 V ... 6 V	Detektorspannung Ausgang FOPU
103	0.00 V ... 6 V	Detektorspannung Mischer
104	0.01 V ... 3 V	RF-Pegel nach Filterbank
105	-6.00 V ... 0 V	Führungswert der Pegelregelung
106	-1.00 V ... 10 V	Ausgangsspannung des Regelverstärkers
107	-1.00 V ... 10 V	Steuerspannung des AM-Modulators
108	0.50 V ... 13 V	Steuerspannung des Stellgliedes LEVEL PRESET

7.2 Meßgeräte und Hilfsmittel

- Spektrumanalysator (z.B. FSBS)
- Oszilloskop (z.B. BOL)
- Gleichspannungsmeßgerät (Multimeter, z.B. UDL33)
- Netzwerkanalysator (z.B. ZVR)
- RF-Pegelmesser (z.B. NRVD mit Meßkopf NRV-Z51)
- 10dB-N-Dämpfungsglied (z.B. DNF)

7.3 Fehlersuche

Vor dem Öffnen des Gerätes ist es zweckmäßig, zuerst einmal die Kalibrieroutine LEVEL PRESET zu starten und an Hand der Diagnosespannungen mögliche Fehlerquellen zu lokalisieren.

7.3.1 Fehler nur im Bereich $f_{RF} < 10$ MHz

falscher RF-Pegel an X226

Der Detektor im Mischbereich liefert eine falsche Spannung oder der PI-Regler wird nicht richtig angesteuert.
Spannung VDETMIX mit Spezialfunktion 103 prüfen.

schlechter AM-Klirrfaktor

Linearisierungsschaltung des Detektors prüfen.

7.3.2 Fehler nur im Bereich $f_{RF} < 65$ MHz

- falscher RF-Pegel an X226** Eingang REF640, ZF-Verstärker, RF-Verstärker 4 und die Ansteuerung SBDON-P und SBDON-N der Umschalter prüfen.
- Oberwellen zu groß** Prüfe ZF-Verstärker, ZF-Tiefpaß und RF-Schalter SWITCHB.
- Nebenwellen zu groß** Der Mischer ist defekt oder er wird mit zu hohem RF-Pegel angesteuert (Sollpegel am Mischer-RF-Eingang < -5 dBm). Prüfe ZF-Verstärker, ZF-Tiefpaß, RF-Schalter SWITCHB und den RF-Tiefpaß.

7.3.3 Fehler im Bereich $5 \text{ kHz} \leq f_{RF} \leq 1040$ MHz

- kein RF-Pegel an X226** Die Steuerspannung des AM-Modulators muß jetzt > 12 V sein, sonst arbeitet die Pegelregelung nicht richtig oder der Führungswert vom RFLEV-D/A-Wandler ist falsch. Pegel nach Filterbank prüfen (Spezialfunktion 104). Mit Spektrumanalysator mit RF-Tastkopf mit DC-Trennung die RF-Kette kontrollieren (die Sollverstärkung einzelner Verstärkerstufen beträgt ca. 7 dB)
- Oberwellen zu groß** Prüfe Filterbank und folgende RF-Verstärker-Kette, prüfe Arbeitspunkte des Endverstärkers.
- Stör-Phasenmodulation bei AM zu groß** Prüfe die Ansteuerspannung des AM-Modulators. Kalibrierung LEVEL PRESET am Gerät durchführen.
- AM-Klirrfaktor zu groß** Prüfen und Abgleich von Detektor und Linearisierungsschaltung, Kontrolle der AMSLOW-Ansteuerung.

7.3.4 Spektrale Reinheit, $\Delta f < 10$ MHz vom Träger

Seitenlinien in ca. 1 MHz
Abstand vom Träger

Pegel-Regelschleife schwingt;
Prüfe Detektor und
Linearisierungsschaltung.
Kalibrierung LEVEL PRESET
durchführen.

7.4 Prüfen und Abgleich

Vorbemerkung: Neben den Koppelkondensatoren bzw. -widerständen der RF-Kette befinden sich Massedurchkontaktierungen. An einer solchen Stelle kann ein Koaxialkabel eingelötet und über einen Koppelkondensator oder eine externe DC-Trennung ein Meßgerät (z.B. Netzwerk- oder Spektrumanalysator) angeschlossen werden. Hierzu wird das Koaxialkabel durch das Loch gesteckt, der Außenleiter des Koaxialkabels an der Durchkontaktierung und der Innenleiter am gewünschten Anschlußfleck des Kondensators angelötet.

7.4.1 Prüfen der Datenübertragung

Die Prüfung wird bei den in der Tabelle angegebenen Einstellungen am Gerät durchgeführt.

— Prüfen der Spannungen an D120:

"1" = +5 V, "0" = 0 V

RF-Frequenz	D120/14	D120/6 Hinweis
RF 1MHz	0 1	DETMIXON
RF 10MHz	1 0	DETON

7.4.2 Prüfen der Ausgangsspannung des Regelverstärkers

Um den Amplitudenmodulator optimal betreiben zu können ist die LEVEL PRESET-Kalibrierung erforderlich. Dieser optimale Arbeitspunkt ist unabhängig von der RF-Frequenz. Die Ausgangsspannung des Regelverstärkers soll bei einem Ausgangspegel von 13dBm (+19 dBm mit Option SMY-B40) 6.3V betragen. Bei elektronischer Pegelabsenkung auf 7dBm (+13 dBm mit Option SMY-B40) soll diese Spannung auf 3.9V absinken und bei weiterer elektronischer Pegelabsenkung bis zu -6dBm (0 dBm mit Option SMY-B40) konstant auf 3.9V bleiben.

- Den Geräteausgang RF 50 Ω mit 50 Ω abschließen.
 - LEVEL 13 dBm (+19 dBm mit Option SMY-B40) einstellen und
 - Spezialfunktion 1 (unterbrechungsfreie PegelEinstellung) einschalten.
- Über die Spezialfunktion 106 kann die Ausgangsspannung des Regelverstärkers gemessen werden.

7.4.3 Prüfen der LEVEL PRESET-Steuerspannung

- Den Geräteausgang RF 50Ω mit 50Ω abschließen.
 - LEVEL 13 dBm (+19 dBm mit Option SMY-B40) einstellen
 - Spezialfunktion 1 (unterbrechungsfreie PegelEinstellung) einschalten.
- Über die Spezialfunktion 108 kann die LEVEL PRESET-Spannung gemessen werden.
Die Spannung ist abhängig von der RF-Frequenz und vom RF-Pegel.
Der Rechner sendet die berechneten Werte in den LEVEL PRESET-D/A-Wandler.

Typische Spannungswerte sind in folgender Tabelle dargestellt:

RF-Frequenz	SMY01 ohne Option SMY-B40				SMY01 mit Option SMY-B40			
	13dBm	7dBm	0dBm	-6dBm	19dBm	13dBm	6dBm	0dBm
25MHz	1.2V	1.2V	0.8V	0.6V	1.2V	1.2V	0.8V	0.6V
100MHz	1.7V	1.7V	1.2V	0.8V	1.7V	1.7V	1.2V	0.8V
300MHz	1.2V	1.2V	0.9V	0.6V	1.2V	1.2V	0.9V	0.6V
500MHz	1.3V	1.3V	0.9V	0.6V	1.3V	1.3V	0.9V	0.6V
750MHz	2.0V	2.0V	1.4V	1.0V	2.0V	2.0V	1.4V	1.0V
800MHz	1.5V	1.5V	1.0V	0.8V	1.5V	1.5V	1.0V	0.8V
1040MHz	2.0V	2.0V	1.4V	1.0V	2.0V	2.0V	1.4V	1.0V

7.4.4 Prüfen der Arbeitspunkte der Verstärkerstufen

Prüfpunkt	Sollspannung	Bemerkung
N360/3	5.50 ± 1.1V	RF AMPLIFIER 2
N410/3	5.50 ± 1.1V	RF AMPLIFIER 3
V602 Kollektor	8.90 ± 0.3V	RF AMPLIFIER 4
V612 Kollektor	5.90 ± 0.3V	IF AMPLIFIER
V802 Kollektor	9.60 ± 0.3V	OUTPUT AMPLIFIER 1
V817 Kollektor	8.70 ± 0.3V	OUTPUT AMPLIFIER 2
V822 Kollektor	8.80 ± 0.3V	OUTPUT AMPLIFIER 3

7.4.5 Prüfen der Ansteuerung der Filterbank

– Prüfen von LPSELECT-0 ... LPSELECT-3 und der Schaltleitungen TP0 ... TP8.

RF-Frequenz	LPSELECT-				Hinweis
	2	1	0	0	
D111/8	D111/11	D111/6	D111/3		
780.00 MHz	0	0	0	1	Tiefpaß 1
520.00 MHz	0	0	1	0	Tiefpaß 2
390.00 MHz	0	0	1	1	Tiefpaß 3
260.00 MHz	0	1	0	0	Tiefpaß 4
195.00 MHz	0	1	0	1	Tiefpaß 5
130.00 MHz	0	1	1	0	Tiefpaß 6
97.50 MHz	0	1	1	1	Tiefpaß 7
65.00 MHz	1	0	0	0	Tiefpaß 8
64.00 MHz	0	0	1	0	Tiefpaß 2, Mischerbereich

7.4.6 Prüfen des RF-Pegels nach der Filterbank

- Den Geräteausgang RF 50Ω mit 50Ω abschließen.
- Einstellung: RF LEVEL 13 dBm (+19 dBm mit Option SMY-B40)
- _ Über die Spezialfunktion 104 kann die gleichgerichtete RF-Spannung gemessen werden.

Typische Spannungswerte sind in folgender Tabelle dargestellt:

RF-Frequenz	Diagnosespannung	
10 MHz	0.2V	
100 MHz	0.7V	
200 MHz	1.1V	
300 MHz	1.0V	
400 MHz	1.3V	
500 MHz	1.4V	
600 MHz	1.4V	
700 MHz	1.0V	
800 MHz	1.4V	
900 MHz	0.6V	
1000 MHz	1.5V	
1040 MHz	2.5V	

7.4.7 Abgleich der ZF-Verstärkung

- Spektrumanalysator an Geräteausgang RF 50Ω anschließen
- Einstellung: RF 10 MHz
LEVEL 13 dBm (+19 dBm mit Option SMY-B40)
- _ RF-Signal messen, RF-Pegel merken
- _ RF-Frequenz um 1 Hz erniedrigen
- _ Mit Pot R645 den RF-Pegel auf den gleichen Wert einstellen
- _ Nach dem Abgleich sollte die Kalibrierroutine LEVEL PRESET aufgerufen werden.

7.4.8 Abgleich der ZF-Detektor-Linearität

- Einstellung: RF 9.9 MHz
LEVEL 0.1 dBm (6.1 dBm mit Option SMY-B40)
- _ Ausgangspegel am RF-Ausgang des Gerätes messen und merken (= Referenzpegel)
- Einstellung: Spezialfunktion 1 einschalten
(unterbrechungsfreie PegelEinstellung)
LEVEL -19.9 dBm (-13.9 dBm mit Option SMY-B40)
- _ Mit POT R619 so abgleichen, daß der gemessene Pegel 20 dB unter dem zuvor gemessenen Referenzpegel liegt. Abgleich einmal wiederholen, da sich der Referenzwert mit R619 geringfügig ändert; die Genauigkeit der 20dB-Absenkung soll nach dem Abgleich ± 0.1 dB erreichen.

7.4.9 Abgleich der Detektor-Linearität am Ausgang FOPU

- Dieser Abgleich darf nur dann durchgeführt werden, wenn **keine** Option SMY-B40 eingebaut ist!

- Einstellung: RF 100 MHz
 LEVEL 13 dBm

_ Ausgangspegel am RF-Ausgang des Gerätes messen und merken (= Referenzpegel)

- Einstellung: Spezialfunktion 1 einschalten
 (unterbrechungsfreie Pegeleinstellung)
 LEVEL -7 dBm

_ Mit POT R851 so abgleichen, daß der gemessene Pegel 20 dB unter dem zuvor gemessenen Referenzpegel liegt. Abgleich einmal wiederholen, da sich der Referenzwert mit R851 ändert; die Genauigkeit der 20dB-Absenkung soll nach dem Abgleich ± 0.1 dB erreichen.

7.4.10 Abgleich des AM-Modulationsgrades

- Einstellung: PRESET
 LEVEL 7 dBm (+13 dBm mit Option SMY-B40)
 AM EXT DC 100%
 Spezialfunktion 105 einschalten
 (Führungswert der Pegelregelung)

- Eine Gleichspannung $U = -1.000$ V an AM EXT anlegen.

_ Mit POT R280 auf 0 V abgleichen.

7.5 Zerlegung und Zusammenbau

Oberen Gerätedeckel entfernen. Die Baugruppe ist links und rechts an der Auflage festgeschraubt. Nach dem Entfernen dieser Schrauben und dem Lösen der Koax-Verbindungen an X224, X225 und X226 kann die Baugruppe aus ihrem Steckplatz entnommen werden.

7.6 Endprüfung

7.6.1 Prüfen des maximalen Ausgangspegels

- Einstellung: LEVEL 19 dBm (25 dBm mit Option SMY-B40)
- _ An X226 FOPU einen Leistungsmesser anschließen, dabei muß ggf. ein geeignetes RF-Dämpfungsglied vorgeschaltet werden, um den Meßkopf nicht zu überlasten.
- _ RF-Frequenz von 5kHz bis 1040 MHz variieren.
Der RF-Pegel muß > 15dBm (20 dBm mit Option SMY-B40) bleiben.

Typische Pegelwerte sind in folgender Tabelle dargestellt:

	SMY01 ohne Option SMY-B40	SMY01 mit Option SMY-B40
RF-Frequenz	Ausgangspegel	Ausgangspegel
10 MHz	16 dBm	21 dBm
100 MHz	19 dBm	24 dBm
200 MHz	19 dBm	26 dBm
250 MHz	19 dBm	25 dBm
400 MHz	20 dBm	24 dBm
500 MHz	18 dBm	25 dBm
600 MHz	18 dBm	26 dBm
750 MHz	17 dBm	26 dBm
800 MHz	19 dBm	26 dBm
1000 MHz	18 dBm	26 dBm

7.6.2 Prüfen des Oberwellenabstandes

- Gerät ohne Option SMY-B40:
- Einstellung: LEVEL 10 dBm
- _ An X226 FOPU einen Spektrumanalysator anschließen.
- _ Der Pegel der Harmonischen muß < -30 dBc sein.

- Gerät mit Option SMY-B40:
- Einstellung: LEVEL 16 dBm
 Spezial 21 (ALC aus)

Da für die Messung die Verbindung von FOPU zum Powermodul aufgetrennt wird, muß die Pegelregelung auf den Sample-and-Hold-Betrieb geschaltet werden. Vor jeder Änderung der Geräteeinstellung muß diese Verbindung wieder geschlossen werden!

- _ Meßfrequenz einstellen.
- _ An X226 FOPU einen Spektrumanalysator anschließen.
- _ Der Pegel der Harmonischen muß <-25 dBc sein.

Typische Meßwerte sind in folgender Tabelle dargestellt:

RF-Frequenz	SMY01 ohne Option SMY-B40		SMY01 mit Option SMY-B40	
	2*f _{RF}	3*f _{RF}	2*f _{RF}	3*f _{RF}
1 MHz	-50 dBc	-40 dBc	-45 dBc	-50 dBc
10 MHz	-50 dBc	-45 dBc	-50 dBc	-50 dBc
100 MHz	-50 dBc	-40 dBc	-50 dBc	-50 dBc
200 MHz	-45 dBc	-45 dBc	-50 dBc	-50 dBc
350 MHz	-50 dBc	-40 dBc	-50 dBc	-50 dBc
650 MHz	-50 dBc	-40 dBc	-45 dBc	-50 dBc
900 MHz	-35 dBc	-45 dBc	-40 dBc	-50 dBc
1040 MHz	-45 dBc	-45 dBc	-40 dBc	-50 dBc

7.6.3 Prüfen des Nebenwellenabstandes

- Einstellung: RF 63 MHz
LEVEL 13 dBm (+19 dBm mit Option SMY-B40)

- _ An X226 FOPU einen Spektrumanalysator anschließen.
- _ Nebenwellen bei folgenden Frequenzen prüfen:
703 MHz, 640 MHz, 136 MHz, 73 MHz, 10 MHz
Der Pegel der Nebenwellen muß < -70 dBc sein (typ. < -100 dBc).

7.7 Externe Schnittstellen

Pin	Name	Ein/Ausgang	Herkunft/Ziel	Wertebereich	Signalbeschreibung
X2A.01	BLANK	Eingang	Rückwanne	HCMOS-Pegel	RF-Pegelaustastung
X2A.05	DETEXT	Eingang	Pmod	0 ... 10 V	Detektorspg. Option SMY-B40
X2A.07	AMMOD	Eingang	CPU X3.3	4-1 V bis 1 V	AM-Signal
X2A.12	SERCLK	Eingang	CPU X3.2	HCMOS-Pegel	Clock
X2A.14	SERDAT	Eingang	CPU X3.4	HCMOS-Pegel	serielle Daten
X2A.15	AT1STB	Eingang	CPU X3.16	HCMOS-Pegel	Strobe 1
X2A.17	HFINT	Ausgang	CPU X3.20	HCMOS-Pegel	Interrupt Pegelregelung
X2A.19	DIAG-5V	Ausgang	CPU X3.6	-5 V..5 V	Diagnose
X2A.22	VA24-P	Eingang	Netzteil X21.22	23.4 V..24.6 V	Versorgungsspannung analog
X2A.24	VA15-P	Eingang	Netzteil X21.13	14.80 V..15.75 V	Versorgungsspannung analog
X2A.25					
X2A.28	VA-5P	Eingang	Netzteil X21.5	5.10 V..5.25 V	Versorgungsspannung analog
X2A.30	VA15-N	Eingang	Netzteil X21.20	-15.75 V..-14.85 V	Versorgungsspannung analog
X224	FSYN	Eingang	YSYN X124	6 - 12 dBm	65 - 1040 MHz
X225	REF640	Eingang	YSYN X125	9 - 12 dBm	640 MHz
X226	FOPU	Ausgang	Eichleitung X1	-6...20 dBm	5 kHz - 1.04 GHz



ROHDE & SCHWARZ

SERVICE INSTRUCTIONS

Output Module 1.04 GHz

1062.6209.01

Contents

7 Testing and Repair of the Module.....	5
7.1 Function Description.....	5
7.1.1 RF Signal Processing.....	5
7.1.2 Mixer with LO, RF and IF Filters.....	6
7.1.3 Output Amplifier.....	6
7.1.4 AM Signal Path and Nominal Value of RF Level.....	6
7.1.5 RF Level Control.....	6
7.1.6 Serial Interface.....	7
7.1.7 Circuit for Diagnostics Selection.....	7
7.2 Test Instruments and Utilities.....	7
7.3 Troubleshooting.....	7
7.3.1 Errors Occurring Only in the Range $f_{RF} < 10$ MHz.....	7
7.3.2 Errors Occurring Only in the Range $f_{RF} < 65$ MHz.....	8
7.3.3 Errors Occurring in Range $5 \text{ kHz} \leq f_{RF} \leq 1040$ MHz.....	8
7.3.4 Spectral Purity, $\Delta f < 10$ MHz from the Carrier... ..	8
7.4 Testing and Adjustment.....	9
7.4.1 Testing Data Transmission.....	9
7.4.2 Testing the Output Voltage of the Control Amplifier..	9
7.4.3 Testing the LEVEL PRESET Control Voltage.....	9
7.4.4 Testing the Operating Points of Amplifier Stages....	10
7.4.5 Testing the Harmonic Filters Control.....	10
7.4.6 Testing the RF Level at the Harmonic Filters Output..	10
7.4.7 IF Gain Adjustment.....	11
7.4.8 IF Detector Linearity Adjustment.....	11
7.4.9 Detector Linearity Adjustment at the Output FOPU....	12
7.4.10 AM Depth Adjustment.....	12
7.5 Disassembly and Assembly.....	12
7.6 Final Test.....	13
7.6.1 Maximum Output Level Check.....	13
7.6.2 Harmonics Suppression Check.....	13
7.6.3 Nonharmonics Suppression Check.....	14
7.7 External Interfaces.....	14

Parts list
List of coordinates
Circuit diagram
Component layout diagram

In instruments without fitted option SMY-B40, this module has the variant VAR 02.

In instruments with fitted option SMY-B40, this module has the variant VAR 03.

7.1 Function Description

The Output Module 1.04 GHz is provided with the RF signal (6 dBm to 12 dBm) in the frequency range $65 \text{ MHz} \leq f_{\text{SYN}} \leq 1040 \text{ MHz}$ by the synthesis module via the input FSYN. This RF signal is passed via an amplitude modulator and an amplitude control element to switchable harmonic filters. The output frequency range of $5 \text{ kHz} \leq f_{\text{RF}} \leq 65 \text{ MHz}$ is realized in the signal path via changeover switches by means of downconversion with a 640 MHz LO.

The module consists of the subsequent function units:

- an AM modulator for level control and amplitude modulation,
- an AM modulator for level presetting (LEVEL PRESET),
- switchable harmonic filters,
- a mixer with LO, RF and IF filters,
- a level detector in the RF path preceding the mixer,
- an output amplifier,
- a level detector at the output FOPU,
- a signal path for processing the nominal value of the RF level and the amplitude-modulation depth,
- the RF level control,
- a serial interface and
- a circuit for diagnostics selection.

Further information on levels apply for an instrument output level of +13 dBm (+ 19 dBm with option SMY-B40).

7.1.1 RF Signal Processing

The input X224 FSYN is followed by an attenuator for temperature compensation. The attenuator is followed by the AM MODULATOR.

It is used as control element for level control in the range $f_{\text{RF}} \leq 1.04 \text{ GHz}$.

The RF signal is amplified by RF AMPLIFIER 1 and RF AMPLIFIER 2 and passed to the PIN modulator LEVEL PRESET. This modulator is set by means of stored calibration data via the D/A converter such that the control element for level control can be operated in an optimum operating point. (cf. operating manual "Calibrating LEVEL PRESET").

The RF signal is amplified by the RF AMPLIFIER 3 and routed to switchable HARMONIC FILTERS. These filters are switched on by the controller depending on the input frequency at X224 FSYN. Similar to the lowpass filters TP4 to TP8, the lowpass filters TP0 to TP3 are cascaded. Filters in the signal path which have a higher cutoff frequency than the cutoff frequency of the lowpass selected remain switched on.

In "normal operation", the RF signal passes via the PIN switch SWITCHD (OFF) and the GaAs changeover switch SWITCHB (OFF) to the output amplifier. In "mixer operation" the RF signal is passed via the PIN switch SWITCHD (ON) and the RF AMPLIFIER 4 to the detector preceding the mixer.

7.1.2 Mixer with LO, RF and IF Filters

The RF signal supplied by the detector preceding the mixer is switched via the RF lowpass and an attenuator to the RF input of the mixer for level adjustment (level approx. -5 to -10 dBm). The signal of REF 640 passes via a lowpass to the LO input of the mixer. The IF signal reaches the RF switch SWITCHB (ON) preceding the output amplifier via the IF amplifier and the IF lowpass ($5 \text{ kHz} \leq f_{ZF} < 65 \text{ MHz}$, level approx. 0 dBm).

7.1.3 Output Amplifier

The three-stage linear broadband amplifier amplifies the input signal by approx. 19 dB. The collector currents of the stages are controlled.

7.1.4 AM Signal Path and Nominal Value of RF Level

The signal of the AMMOD line is passed to the D/A converter for setting of the modulation depth and then passes to the D/A converter RFLEV for RF-level adjustment.

7.1.5 RF Level Control

For instruments without option SMY-B40, the level detector at the output X226 FOPU is used at instrument frequencies $f_{RF} \geq 10 \text{ MHz}$. The RF level at the diode is approx. +19 dBm. The linearization circuit allows for a dynamic range of approx. 30 dB with good linearity (important for low AM distortion).

For instruments with option SMY-B40, the detector of the option SMY-B40 is used for level control at instrument frequencies $\geq 10 \text{ MHz}$. Its output voltage is applied to the motherboard via cable W125 and then fed into the input X2.A5 DETEXT of this module.

The level detector in the RF path preceding the mixer is used with instrument frequencies $f_{RF} < 10 \text{ MHz}$ instead of the detector at the output X226 FOPU. The RF level at the diode is approx. +15 dBm.

The level is controlled via the PI regulator N235. The reference value is supplied by D/A converter RFLEV and compared to the actual value of one of the three detectors (VDET, DETEXT or VDETMIX) depending on the frequency range. The output voltage of the PI regulator adjusts the AM modulator.

The 3-dB bandwidth of the control loop can be reduced by AMSLOW from approx. 300 kHz to approx. 50 kHz. (see special function 13).

The processor activates KLEMM-N to set the AM modulator to maximum attenuation, which is used, e.g., for frequency changes in order to avoid level spikes.

7.1.6 Serial Interface

The incoming data are clocked into the shift registers and the D/A converters LEVEL PRESET, RFLEV and AM.

7.1.7 Circuit for Diagnostics Selection

One of eight dc voltages can be applied to the diagnostic line via the diagnostic multiplexer. The voltage can be displayed on the instrument display.

Special function	Nominal voltage range	Remark
101	0.00 V ±10 mV	10-kOhm reference to ground
102	0.00 V ... 6 V	Detector voltage output FOPU
103	0.00 V ... 6 V	Detector voltage mixer
104	0.01 V ... 3 V	RF level at harmonic filter output
105	-6.00 V ... 0 V	Reference value of level control
106	-1.00 V ... 10 V	Output voltage of the control amplifier
107	-1.00 V ... 10 V	Control voltage of the AM modulator
108	0.50 V ... 13 V	Control voltage of the control element LEVEL PRESET

7.2 Test Instruments and Utilities

- Spectrum analyzer (e.g., FSBS)
- Oscilloscope (e.g., BOL)
- DC power meter (multimeter, e.g., UDL33)
- Network analyzer (e.g., ZVR)
- RF power meter (e.g., NRVD with sensor NRV-Z51)
- 10-dB-N-attenuator pad (e. g. DNF)

7.3 Troubleshooting

Before opening the instrument, it is useful to first start the calibration routine LEVEL PRESET and localize possible error sources using the diagnostic voltages.

7.3.1 Errors Occurring Only in the Range $f_{RF} < 10$ MHz

Incorrect RF level at X226 Either the detector in the mixed range supplies an incorrect voltage or the PI regulator is not controlled correctly.
Check voltage VDETMIX using special function 103.

Bad AM distortion Check the linearization circuit of the detector.

7.3.2 Errors Occurring Only in the Range $f_{RF} < 65$ MHz

- Incorrect RF level at X226** Check input REF640, IF amplifier, RF amplifier 4 and control of SBDON-P and SBDON-N of the changeover switches.
- Harmonics too high** Check IF amplifier, RF lowpass and RF switch SWITCHB.
- Spurious signals too high** The mixer is either faulty or its input RF level is too high (nominal level at the mixer RF input < -5 dBm). Check IF amplifier, IF lowpass, RF switch SWITCHB and the RF lowpass.

7.3.3 Errors Occurring in Range $5 \text{ kHz} \leq f_{RF} \leq 1040$ MHz

- No RF level at X226** The control voltage of the AM modulator must be > 12 V, otherwise, the level control does not work correctly or the reference value of RFLEV D/A converter is incorrect. Check level at harmonic filter output (special function 104). Check the RF signal path using a spectrum analyzer with RF probe providing dc isolation (the gain of the amplifier stages is approx. 7 dB)
- Harmonics too high** Check harmonic filters and subsequent RF amplifiers, check operating points of the output amplifier.
- Incidental phase modulation with AM too high** Check the control voltage of the AM modulator. Perform LEVEL PRESET calibration .
- AM distortion too high** Adjust and check detector and linearization circuit, check AMSLOW control.

7.3.4 Spectral Purity, $\Delta f < 10$ MHz from the Carrier

- Spurious signals at approx. 1 MHz from carrier** ALC control loop oscillates; check detector and linearization circuit. Perform LEVEL PRESET calibration.

7.4 Testing and Adjustment

Hints: *Ground via-holes have been fitted next to the coupling capacitors and resistors of the RF signal path. A coaxial cable can be soldered in at such a location and a test instrument can be connected via a coupling capacitor or an external dc isolation (e.g., a network or spectrum analyzer). Therefore, the coaxial cable is routed through the hole, the external conductor is soldered at the via-hole and the inner conductor at the desired location.*

7.4.1 Testing Data Transmission

The test is performed with the instrument settings listed in the table.

- Check the voltages at D120:
"1" = +5 V, "0" = 0 V

RF frequency	D120/14	D120/6	Remark
RF 1MHz	0	1	DETMIXON
RF 10MHz	1	0	DETON

7.4.2 Testing the Output Voltage of the Control Amplifier

The LEVEL PRESET calibration is required for optimum operation of the amplitude modulator. This optimum operating point is independent of the RF frequency. The nominal output voltage of the control amplifier is 6.3 V for an output level of 13 dBm (+19 dBm with option SMY-B40). When the level is decreased electronically to 7dBm (+13 dBm with option SMY-B40), this voltage should drop to 3.9V and should remain constant even with further electronic reduction of the level down to -6 dBm (0 dBm with option SMY-B40).

- Terminate the instrument output RF 50Ω with 50Ω.
 - Set LEVEL to 13 dBm (+19 dBm with option SMY-B40) and
 - switch on special function 1 (non-interrupting level setting)
- The output voltage of the control amplifier can be measured using special function 106.

7.4.3 Testing the LEVEL PRESET Control Voltage

- Terminate the instrument output RF 50Ω with 50Ω.
 - Set LEVEL to 13 dBm. (+19 dBm with option SMY-B40)
 - Switch on special function 1 (non-interrupting level setting)
- The LEVEL PRESET voltage can be measured using special function 108.
- The voltage depends on the RF frequency and the RF level. The controller transmits the calculated values to the LEVEL PRESET D/A converter.

Typical voltages are given in the table below:

RF- frequency	SMY01 without option SMY-B40				SMY01 with option SMY-B40			
	13 dBm	7 dBm	0 dBm	-6 dBm	19 dBm	13 dBm	6 dBm	0 dBm
25 MHz	1.2 V	1.2 V	0.8 V	0.6 V	1.2 V	1.2 V	0.8 V	0.6 V
100 MHz	1.7 V	1.7 V	1.2 V	0.8 V	1.7 V	1.7 V	1.2 V	0.8 V
300 MHz	1.2 V	1.2 V	0.9 V	0.6 V	1.2 V	1.2 V	0.9 V	0.6 V
500 MHz	1.3 V	1.3 V	0.9 V	0.6 V	1.3 V	1.3 V	0.9 V	0.6 V
750 MHz	2.0 V	2.0 V	1.4 V	1.0 V	2.0 V	2.0 V	1.4 V	1.0 V
800 MHz	1.5 V	1.5 V	1.0 V	0.8 V	1.5 V	1.5 V	1.0 V	0.8 V
1040 MHz	2.0 V	2.0 V	1.4 V	1.0 V	2.0 V	2.0 V	1.4 V	1.0 V

7.4.4 Testing the Operating Points of Amplifier Stages

Test point	Nominal voltage	Remark
N360/3	5.50 ± 1.1V	RF AMPLIFIER 2
N410/3	5.50 ± 1.1V	RF AMPLIFIER 3
V602 Collector	8.90 ± 0.3V	RF AMPLIFIER 4
V612 Collector	5.90 ± 0.3V	IF AMPLIFIER
V802 Collector	9.60 ± 0.3V	OUTPUT AMPLIFIER 1
V817 Collector	8.70 ± 0.3V	OUTPUT AMPLIFIER 2
V822 Collector	8.80 ± 0.3V	OUTPUT AMPLIFIER 3

7.4.5 Testing the Harmonic Filters Control

_ Testing LPSELECT-0 ... LPSELECT-3 and the lines TP0 to TP8.

RF frequency	LPSELECT-				Remark
	2	1	0	0	
D111/8	D111/11	D111/6	D111/3		
780.00 MHz	0	0	0	1	Lowpass 1
520.00 MHz	0	0	1	0	Lowpass 2
390.00 MHz	0	0	1	1	Lowpass 3
260.00 MHz	0	1	0	0	Lowpass 4
195.00 MHz	0	1	0	1	Lowpass 5
130.00 MHz	0	1	1	0	Lowpass 6
97.50 MHz	0	1	1	1	Lowpass 7
65.00 MHz	1	0	0	0	Lowpass 8
64.00 MHz	0	0	1	0	Lowpass 2, Mixer range

7.4.6 Testing the RF Level at the Harmonic Filters Output

- Terminate the instrument output RF 50Ω with 50Ω.
 - Setting: RF LEVEL 13 dBm (+19 dBm with option SMY-B40)
- _ The rectified RF voltage can be measured using special function 104.

Typical voltages are given in the table below:

RF frequency	Diagnostic voltage
10 MHz	0.2V
100 MHz	0.7V
200 MHz	1.1V
300 MHz	1.0V
400 MHz	1.3V
500 MHz	1.4V
600 MHz	1.4V
700 MHz	1.0V
800 MHz	1.4V
900 MHz	0.6V
1000 MHz	1.5V
1040 MHz	2.5V

7.4.7 IF Gain Adjustment

- Connect a spectrum analyzer to the instrument output RF 50Ω.
- Setting: RF 10 MHz
LEVEL 13 dBm (+19 dBm with option SMY-B40)
- Measure RF signal, note RF level
- Decrease RF frequency by 1 Hz
- Adjust the RF level to the same value using the potentiometer R645
- Subsequent to adjustment, call the calibration routine LEVEL PRESET.

7.4.8 IF Detector Linearity Adjustment

- Setting: RF 9.9 MHz
LEVEL 0.1 dBm (6.1 dBm with option SMY-B40)
- Measure and note the output level at the RF output (= reference level)
- Setting: Switch on special function 1
(non-interrupting level setting)
LEVEL -19.9 dBm (-13.9 dBm with option SMY-B40)
- Adjust R619 that the measured level is 20 dB below the previously measured reference level. Repeat adjustment once, since the reference value slightly changes with use of R619; after the adjustment, the accuracy of the 20 dB reduction shall reach ± 0.1 dB.

7.4.9 Detector Linearity Adjustment at the Output FOPU

This adjustment must be carried out only if option SMY-B40 is **not** fitted!

- Setting: RF 100 MHz
 LEVEL 13 dBm

- Measure and note the output level at the RF output of the instrument (= reference level)

- Setting: Switch on special function 1
 (non-interrupting level setting)
 LEVEL -7 dBm

- Adjust R851 that the measured level is 20 dB below the previously measured reference level. Repeat adjustment once, since the reference value changes with use of R851; the accuracy of the 20 dB reduction shall reach ± 0.1 dB.

7.4.10 AM Depth Adjustment

- Setting: PRESET
 LEVEL 7 dBm (+13 dBm with option SMY-B40)
 AM EXT DC 100%
 Switch on special function 105
 (reference value of level control)

- Apply a dc voltage $V = -1.000$ V to AM EXT.

- Adjust to 0 V using R280.

7.5 Disassembly and Assembly

- Remove upper instrument cover.
The module is fixed to the support at the left and right sides. It can be taken out of its slot subsequent to undoing these screws and disconnecting the coaxial connections at X224, X225 and X226.

7.6 Final Test

7.6.1 Maximum Output Level Check

- Setting: LEVEL 19 dBm (25 dBm with option SMY-B40)
- Connect a power meter to X226 FOPU. This may require an adequate RF attenuator pad to be installed so that the power sensor is not overdriven.
- Vary the RF frequency from 5kHz to 1040 MHz. The RF level must remain > 15 dBm (> 20 dBm with option SMY-B40).

Typical levels are given in the table below:

	SMY01 without option SMY-B40	SMY01 with option SMY-B40
RF-frequency	output level	output level
10 MHz	16 dBm	21 dBm
100 MHz	19 dBm	24 dBm
200 MHz	19 dBm	26 dBm
250 MHz	19 dBm	25 dBm
400 MHz	20 dBm	24 dBm
500 MHz	18 dBm	25 dBm
600 MHz	18 dBm	26 dBm
750 MHz	17 dBm	26 dBm
800 MHz	19 dBm	26 dBm
1000 MHz	18 dBm	26 dBm

7.6.2 Harmonics Suppression Check

Instrument without option SMY-B40

- Setting: LEVEL 10 dBm
- Connect a spectrum analyzer to X226 FOPU.
- The level of the harmonics must be < -30 dBc.

Instrument with option SMY-B40

- Setting: LEVEL 16 dBm
Special 21 (ALC off)

As the connection from FOPU to the power module is undone for the measurement, the level control must be switched to sample-and-hold operation. This connection must be reestablished before any of the instrument settings are changed!

- Set measurement frequency:
- Connect spectrum analyzer at X226 FOPU. The level of the harmonic must be < -25 dBc.

Typical values are given in the table below:

RF-frequency	SMY01 without option SMY-B40		SMY01 with option SMY-B40	
	2*f _{RF}	3*f _{RF}	2*f _{RF}	3*f _{RF}
1 MHz	-50 dBc	-40 dBc	-45 dBc	-50 dBc
10 MHz	-50 dBc	-45 dBc	-50 dBc	-50 dBc
100 MHz	-50 dBc	-40 dBc	-50 dBc	-50 dBc
200 MHz	-45 dBc	-45 dBc	-50 dBc	-50 dBc
350 MHz	-50 dBc	-40 dBc	-50 dBc	-50 dBc
650 MHz	-50 dBc	-40 dBc	-45 dBc	-50 dBc
900 MHz	-35 dBc	-45 dBc	-40 dBc	-50 dBc
1040 MHz	-45 dBc	-45 dBc	-40 dBc	-50 dBc

7.6.3 Nonharmonics Suppression Check

- Setting: RF 63 MHz
LEVEL 13 dBm (+19 dBm with option SMY-B40)
- Connect a spectrum analyzer to X226 FOPU.
- Check spurious responses with the subsequent frequencies 703 MHz, 640 MHz, 136 MHz, 73 MHz, 10 MHz
The level of the spurious signals must be < -70 dBc (typ. < -100 dBc).

7.7 External Interfaces

Pin	Name	Input/Output	Origin/Dest.	Specified range	Signal description
X2A.01	BLANK	Input	Rear panel	HCMOS level	RF level blanking
X2A.05	DETEXT	Input	Pmod	0 to 10 V	detector voltage, option SME-B40
X2A.07	AMMOD	Input	CPU X3.34	-1V to 1V	AM signal
X2A.12	SERCLK	Input	CPU X3.2	HCMOS level	Clock
X2A.14	SERDAT	Input	CPU X3.4	HCMOS level	Serial data
X2A.15	AT1STB	Input	CPU X3.16	HCMOS level	Strobe 1
X2A.17	HFINT	Output	CPU X3.20	HCMOS level	Interrupt level control
X2A.19	DIAG-5V	Output	CPU X3.6	-5 to 5V	Diagnostics
X2A.22	VA24-P	Input	Power X21.22	23.4 to 24.6V	Analog supply voltage
X2A.24	VA15-P	Input	Power X21.13	14.80 to 15.75V	Analog supply voltage
X2A.25					
X2A.28	VA-5P	Input	Power X21.5	5.10 to 5.25V	Analog supply voltage
X2A.30	VA15-N	Input	Power X21.20	-15.75to-14.85V	Analog supply voltage
X224	FSYN	Input	YSYN X124	6 - 12 dBm	65 - 1040 MHz
X225	REF640	Input	YSYN X125	9 - 12 dBm	640 MHz
X226	FOPU	Output	Attenuator X1	-6 to 20 dBm	5 kHz - 1.04 GHz



ROHDE & SCHWARZ

**Schaltteillisten
numerisch geordnet
Part lists
in numerical order
Listes des pièces détachées
par numéros de référence**

Für diese Unterlage behalten wir uns alle Rechte vor.

Kennz. Comp. No.	Benennung Designation	Sachnummer Stock No.	Hersteller Manufacturer	Bezeichnung Designation	enthalten in contained in
.	XX VARIANTENERKLAERUNG IDENTIFICATION OF MODELS VAR 02 = GRUNDAUSFUEHRUNG MOD 02 = BASIC_MODEL VAR 03 = SMY11+SMY-B40 UMGERUESTET AUS VAR02 MOD 03 = SMY11+SMY-B40 CONVERTED O.MODO2 VAR 04 = SMY41 MOD 04 = SMY41 VAR 06 = MIT OPT. SMY-B40 UMGERUESTET AUS VAR 04 MOD 06 = WITH OPT. SMY-B40 CONVERTED O.MODO4				
C12	CC 47NF+-10%50V X7R 1206 CERAMIC CHIP CAPACITOR	CC 0007.5195.00	PHILIPS_CO	2238 581 15645	
C13	CC 1NF+-1% 50V NPO 1206 SMD CERAMIC CAPACITOR NICHT BESTUECKT NOT FITTED	CC 0007.7398.00	PHILIPS_CO	2222 863 *8102	
C14	CC 100NF+-10%50V X7R 1206 CERAMIC CHIP CAPACITOR	CC 0007.5237.00	PHILIPS_CO	2238 581 15649	
..17 C20	CE 220UF+-20%10V RM2,5 ELECTROLYTIC CAPACITOR	CE 0008.7927.00	PANASONIC	ECA-1AFG2211	
C21	CE 10UF+-20%35V RD5,5XH6 ELECTROLYTIC CAPACITOR	0803.0667.00	NAT_PANASO	ECE-A1VKS-100	
C22	CE 10UF+-20%35V RD5,5XH6 ELECTROLYTIC CAPACITOR	0803.0667.00	NAT_PANASO	ECE-A1VKS-100	
C132	CC 100NF+-10%50V X7R 1206 CERAMIC CHIP CAPACITOR	CC 0007.5237.00	PHILIPS_CO	2238 581 15649	
C133	CC 100NF+-10%50V X7R 1206 CERAMIC CHIP CAPACITOR	CC 0007.5237.00	PHILIPS_CO	2238 581 15649	
C149	CC 100NF+-10%50V X7R 1206 CERAMIC CHIP CAPACITOR	CC 0007.5237.00	PHILIPS_CO	2238 581 15649	
..154 C156	CC 100NF+-10%50V X7R 1206 CERAMIC CHIP CAPACITOR	CC 0007.5237.00	PHILIPS_CO	2238 581 15649	
C157	CC 100NF+-10%50V X7R 1206 CERAMIC CHIP CAPACITOR	CC 0007.5237.00	PHILIPS_CO	2238 581 15649	
C160	CC 100NF+-10%50V X7R 1206 CERAMIC CHIP CAPACITOR	CC 0007.5237.00	PHILIPS_CO	2238 581 15649	
..162 C170	CC 100NF+-10%50V X7R 1206 CERAMIC CHIP CAPACITOR	CC 0007.5237.00	PHILIPS_CO	2238 581 15649	
C209	CC 22PF+-1%50V NPO 1206 CERAMIC CHIP CAPACITOR	CC 0099.8396.00	MURATA	GRM42-6COG 220F 50PT	
C219	CC 15PF+-1% 50V NPO 1206 CERAMIC CHIP CAPACITOR NUR VAR/ONLY MOD: 02	CC 0099.8750.00	MURATA	GRM42-6COG 150F 50PT	
C219	CC 15PF+-1% 50V NPO 1206 CERAMIC CHIP CAPACITOR NUR VAR/ONLY MOD: 04	CC 0099.8750.00	MURATA	GRM42-6COG 150F 50PT	
C219	CC 33PF+-1%50V NPO 1206 CERAMIC CHIP CAPACITOR NUR VAR/ONLY MOD: 03 06	CC 0099.8780.00	MURATA	GRM42-6COG 330F 50PT	
C220	CC 68PF+-1%50V NPO 1206 CERAMIC CHIP CAPACITOR	CC 0099.8815.00	MURATA	GRM42-6COG 680F 50PT	
C221	CC 8,2PF+-0,25 50VNPO1206 CERAMIC CHIP CAPACITOR NICHT BESTUECKT NOT FITTED	CC 0007.8242.00	MURATA	GRM42-6COG 8R2 C50PT	
C223	CC 2,7PF+-0,25 50VNPO1206 CERAMIC CHIP CAPACITOR NUR VAR/ONLY MOD: 02	CC 0007.8188.00	MURATA	GRM42-6COG 2R7 C50PT	
C223	CC 2,7PF+-0,25 50VNPO1206 CERAMIC CHIP CAPACITOR NUR VAR/ONLY MOD: 04	CC 0007.8188.00	MURATA	GRM42-6COG 2R7 C50PT	
C223	CC 2,7PF+-0,25 50VNPO1206 CERAMIC CHIP CAPACITOR NUR VAR/ONLY MOD: 03 06 NICHT BESTUECKT/NOT FITTED	CC 0007.8188.00	MURATA	GRM42-6COG 2R7 C50PT	
C240	CC 22PF+-1%50V NPO 1206 CERAMIC CHIP CAPACITOR	CC 0099.8396.00	MURATA	GRM42-6COG 220F 50PT	
C242	CC 100PF+-1%50V NPO 1206 CERAMIC CHIP CAPACITOR	CC 0099.8415.00	MURATA	GRM42-6COG 101F 50PT	
C244	CC 100NF+-10%50V X7R 1206 CERAMIC CHIP CAPACITOR	CC 0007.5237.00	PHILIPS_CO	2238 581 15649	

MENP5	413 3PUA	Äl	Datum Date	Schaltteilliste für Parts list for	Sachnummer Stock No.	Blatt-Nr. Page
	14	16.09.97	EE AUSGANGSTEIL 1.04 GHZ	1062.6209.01 SA	1+	

095.0026-0693

Kennz. Comp. No.	Benennung Designation	Sechnummer Stock No.	Hersteller Manufacturer	Bezeichnung Designation	enthalten in contained in
C245	CC 100NF+-10%50V X7R 1206 CERAMIC CHIP CAPACITOR	CC 0007.5237.00	PHILIPS_CD	2238 581 15649	
C250 ..264	CC 100NF+-10%50V X7R 1206 CERAMIC CHIP CAPACITOR	CC 0007.5237.00	PHILIPS_CD	2238 581 15649	
C275	CC 8,2PF+-0,25 50VNP01206 CERAMIC CHIP CAPACITOR	CC 0007.8242.00	MURATA	GRM42-6COG 8R2 C50PT	
C280	CC 22PF+-1%50V NPO 1206 CERAMIC CHIP CAPACITOR	CC 0099.8396.00	MURATA	GRM42-6COG 220F 50PT	
C300	CC 10PF+-0,25 50VNP0 1206 CERAMIC CHIP CAPACITOR	CC 0099.8480.00	MURATA	GRM42-6COG 100 C50PT	
C302	CC 82PF+-1%50V NPO 1206 CERAMIC CHIP CAPACITOR	CC 0099.8821.00	MURATA	GRM42-6COG 820F 50PT	
C303	CC 82PF+-1%50V NPO 1206 CERAMIC CHIP CAPACITOR	CC 0099.8821.00	MURATA	GRM42-6COG 820F 50PT	
C313	CC 100NF+-10%50V X7R 1206 CERAMIC CHIP CAPACITOR	CC 0007.5237.00	PHILIPS_CD	2238 581 15649	
C315	CC 1NF+-1% 50V NPO 1206 SMD CERAMIC CAPACITOR	CC 0007.7398.00	PHILIPS_CD	2222 863 *8102	
C316	CC 1NF+-1% 50V NPO 1206 SMD CERAMIC CAPACITOR	CC 0007.7398.00	PHILIPS_CD	2222 863 *8102	
C318	CC 100NF+-10%50V X7R 1206 CERAMIC CHIP CAPACITOR	CC 0007.5237.00	PHILIPS_CD	2238 581 15649	
C319	CC 100NF+-10%50V X7R 1206 CERAMIC CHIP CAPACITOR	CC 0007.5237.00	PHILIPS_CD	2238 581 15649	
C325	CC 100PF+-1%50V NPO 1206 CERAMIC CHIP CAPACITOR	CC 0099.8415.00	MURATA	GRM42-6COG 101F 50PT	
C327	CC 1NF+-1% 50V NPO 1206 SMD CERAMIC CAPACITOR	CC 0007.7398.00	PHILIPS_CD	2222 863 *8102	
C328	CC 1NF+-1% 50V NPO 1206 SMD CERAMIC CAPACITOR	CC 0007.7398.00	PHILIPS_CD	2222 863 *8102	
C329	CC 100NF+-10%50V X7R 1206 CERAMIC CHIP CAPACITOR	CC 0007.5237.00	PHILIPS_CD	2238 581 15649	
C330	CC 100NF+-10%50V X7R 1206 CERAMIC CHIP CAPACITOR	CC 0007.5237.00	PHILIPS_CD	2238 581 15649	
C340	CC 100NF+-10%50V X7R 1206 CERAMIC CHIP CAPACITOR	CC 0007.5237.00	PHILIPS_CD	2238 581 15649	
C356	CC 82PF+-1%50V NPO 1206 CERAMIC CHIP CAPACITOR	CC 0099.8821.00	MURATA	GRM42-6COG 820F 50PT	
C357	CC 82PF+-1%50V NPO 1206 CERAMIC CHIP CAPACITOR	CC 0099.8821.00	MURATA	GRM42-6COG 820F 50PT	
C359	CC 100NF+-10%50V X7R 1206 CERAMIC CHIP CAPACITOR	CC 0007.5237.00	PHILIPS_CD	2238 581 15649	
C360	CC 220PF+-1%50V NPO 1206 CERAMIC CHIP CAPACITOR	CC 0099.8850.00	PHILIPS_CD	2238 863 18221	
C361	CC 220PF+-1%50V NPO 1206 CERAMIC CHIP CAPACITOR	CC 0099.8850.00	PHILIPS_CD	2238 863 18221	
C362	CC 100NF+-10%50V X7R 1206 CERAMIC CHIP CAPACITOR	CC 0007.5237.00	PHILIPS_CD	2238 581 15649	
C400	CC 100NF+-10%50V X7R 1206 CERAMIC CHIP CAPACITOR	CC 0007.5237.00	PHILIPS_CD	2238 581 15649	
C401	CC 1NF+-1% 50V NPO 1206 SMD CERAMIC CAPACITOR	CC 0007.7398.00	PHILIPS_CD	2222 863 *8102	
C402	CC 1NF+-1% 50V NPO 1206 SMD CERAMIC CAPACITOR	CC 0007.7398.00	PHILIPS_CD	2222 863 *8102	
C404	CC 100NF+-10%50V X7R 1206 CERAMIC CHIP CAPACITOR	CC 0007.5237.00	PHILIPS_CD	2238 581 15649	
C405	CC 100NF+-10%50V X7R 1206 CERAMIC CHIP CAPACITOR	CC 0007.5237.00	PHILIPS_CD	2238 581 15649	
C410	CC 1NF+-1% 50V NPO 1206 SMD CERAMIC CAPACITOR	CC 0007.7398.00	PHILIPS_CD	2222 863 *8102	
C412	CC 220PF+-1%50V NPO 1206 CERAMIC CHIP CAPACITOR	CC 0099.8850.00	PHILIPS_CD	2238 863 18221	
C417	CC 100NF+-10%50V X7R 1206 CERAMIC CHIP CAPACITOR	CC 0007.5237.00	PHILIPS_CD	2238 581 15649	
C440 ..442	CC 100NF+-10%50V X7R 1206 CERAMIC CHIP CAPACITOR	CC 0007.5237.00	PHILIPS_CD	2238 581 15649	
C500	CC 1NF+-1% 50V NPO 1206 SMD CERAMIC CAPACITOR	CC 0007.7398.00	PHILIPS_CD	2222 863 *8102	
C501	CC 100NF+-10%50V X7R 1206 CERAMIC CHIP CAPACITOR	CC 0007.5237.00	PHILIPS_CD	2238 581 15649	
C504	CC 1NF+-1% 50V NPO 1206 SMD CERAMIC CAPACITOR	CC 0007.7398.00	PHILIPS_CD	2222 863 *8102	
C505	CC 2,7PF+-0,25 50VNP01206 CERAMIC CHIP CAPACITOR	CC 0007.8188.00	MURATA	GRM42-6COG 2R7 C50PT	
C506	CC 2,2PF+-0,25 50VNP01206 CERAMIC CHIP CAPACITOR	CC 0007.8171.00	MURATA	GRM42-6COG 2R2 C50PT	
C507	CC 2,2PF+-0,25 50VNP01206 CERAMIC CHIP CAPACITOR	CC 0007.8171.00	MURATA	GRM42-6COG 2R2 C50PT	

Für diese Unterlage behalten wir uns alle Rechte vor.

095.0026-0693

MENP5	413 3PUA	ÄI	Datum Date	Schaltteilliste für Parts list for	Sachnummer Stock No.	Blatt-Nr. Page
	14	16.09.97	EE AUSGANGSTEIL 1.04 GHZ	1002.6209.01 SA	2+	

Für diese Unterlage behalten wir uns alle Rechte vor.

Kennz. Comp. No.	Benennung Designation	Sachnummer Stock No.	Hersteller Manufacturer	Bezeichnung Designation	enthalten in contained in
C509	CC 1NF+-1% 50V NPO 1206 SMD CERAMIC CAPACITOR	CC 0007.7398.00	PHILIPS_CO	2222 863 *8102	
C510	CC 3,3PF+-0,25 50V NPO1206 CERAMIC CHIP CAPACITOR	CC 0007.8194.00	MURATA	GRM42-6COG 3R3 C5OPT	
C511	CC 2,7PF+-0,25 50V NPO1206 CERAMIC CHIP CAPACITOR	CC 0007.8188.00	MURATA	GRM42-6COG 2R7 C5OPT	
C512	CC 2,7PF+-0,25 50V NPO1206 CERAMIC CHIP CAPACITOR	CC 0007.8188.00	MURATA	GRM42-6COG 2R7 C5OPT	
C514	CC 1NF+-1% 50V NPO 1206 SMD CERAMIC CAPACITOR	CC 0007.7398.00	PHILIPS_CO	2222 863 *8102	
C515	CC 4,7PF+-0,25 50V NPO1206 CERAMIC CHIP CAPACITOR	CC 0007.8213.00	MURATA	GRM42-6COG 4R7C 5OPT	
C516	CC 3,9PF+-0,25 50V NPO1206 CERAMIC CHIP CAPACITOR	CC 0007.8207.00	MURATA	GRM42-6COG 3R9 C5OPT	
C517	CC 3,9PF+-0,25 50V NPO1206 CERAMIC CHIP CAPACITOR	CC 0007.8207.00	MURATA	GRM42-6COG 3R9 C5OPT	
C518	CC 1NF+-1% 50V NPO 1206 SMD CERAMIC CAPACITOR	CC 0007.7398.00	PHILIPS_CO	2222 863 *8102	
C519	CC 1,5PF+-0,25 50V NPO1206 CERAMIC CHIP CAPACITOR	CC 0007.8159.00	MURATA	GRM42-6COG 1R5 C5OPT	
C520	CC 1,2PF+-0,25 50V NPO1206 CERAMIC CHIP CAPACITOR	CC 0007.8142.00	MURATA	GRM42-6COG 1R2 C5OPT	
C521	CC 1,2PF+-0,25 50V NPO1206 CERAMIC CHIP CAPACITOR	CC 0007.8142.00	MURATA	GRM42-6COG 1R2 C5OPT	
C526	CC 100NF+-10%50V X7R 1206 CERAMIC CHIP CAPACITOR	CC 0007.5237.00	PHILIPS_CO	2238 581 15649	
C527	CC 1NF+-1% 50V NPO 1206 SMD CERAMIC CAPACITOR	CC 0007.7398.00	PHILIPS_CO	2222 863 *8102	
C530	CC 1NF+-1% 50V NPO 1206 SMD CERAMIC CAPACITOR	CC 0007.7398.00	PHILIPS_CO	2222 863 *8102	
C531	CC 1NF+-1% 50V NPO 1206 SMD CERAMIC CAPACITOR	CC 0007.7398.00	PHILIPS_CO	2222 863 *8102	
C532	CC 10PF+-0,25 50V NPO 1206 CERAMIC CHIP CAPACITOR	CC 0099.8480.00	MURATA	GRM42-6COG 100 C5OPT	
C533	CC 8,2PF+-0,25 50V NPO1206 CERAMIC CHIP CAPACITOR	CC 0007.8242.00	MURATA	GRM42-6COG 8R2 C5OPT	
C534	CC 8,2PF+-0,25 50V NPO1206 CERAMIC CHIP CAPACITOR	CC 0007.8242.00	MURATA	GRM42-6COG 8R2 C5OPT	
C536	CC 1NF+-1% 50V NPO 1206 SMD CERAMIC CAPACITOR	CC 0007.7398.00	PHILIPS_CO	2222 863 *8102	
C537	CC 18PF+-1% 50V NPO 1206 CERAMIC CHIP CAPACITOR	CC 0099.8767.00	MURATA	GRM42-6COG 18OF 5OPT	
C538	CC 12PF+-1% 50V NPO 1206 CERAMIC CHIP CAPACITOR	CC 0099.8744.00	MURATA	GRM42-6COG 120 F5OPT	
C539	CC 12PF+-1% 50V NPO 1206 CERAMIC CHIP CAPACITOR	CC 0099.8744.00	MURATA	GRM42-6COG 120 F5OPT	
C540	CC 1NF+-1% 50V NPO 1206 SMD CERAMIC CAPACITOR	CC 0007.7398.00	PHILIPS_CO	2222 863 *8102	
C545	CC 27PF+-1%50V NPO 1206 CERAMIC CHIP CAPACITOR	CC 0099.8409.00	MURATA	GRM42-6COG 27OF 5OPT	
C546	CC 18PF+-1% 50V NPO 1206 CERAMIC CHIP CAPACITOR	CC 0099.8767.00	MURATA	GRM42-6COG 18OF 5OPT	
C547	CC 18PF+-1% 50V NPO 1206 CERAMIC CHIP CAPACITOR	CC 0099.8767.00	MURATA	GRM42-6COG 18OF 5OPT	
C553	CC 1NF+-1% 50V NPO 1206 SMD CERAMIC CAPACITOR	CC 0007.7398.00	PHILIPS_CO	2222 863 *8102	
C560	CC 33PF+-1%50V NPO 1206 CERAMIC CHIP CAPACITOR	CC 0099.8780.00	MURATA	GRM42-6COG 33OF 5OPT	
C562	CC 27PF+-1%50V NPO 1206 CERAMIC CHIP CAPACITOR	CC 0099.8409.00	MURATA	GRM42-6COG 27OF 5OPT	
C564	CC 22PF+-1%50V NPO 1206 CERAMIC CHIP CAPACITOR	CC 0099.8396.00	MURATA	GRM42-6COG 22OF 5OPT	
C568	CC 5,6PF+-0,25 50V NPO1206 CERAMIC CHIP CAPACITOR	CC 0007.8220.00	MURATA	GRM42-6COG 5R6 C5OPT	
C569	CC 1NF+-1% 50V NPO 1206 SMD CERAMIC CAPACITOR	CC 0007.7398.00	PHILIPS_CO	2222 863 *8102	
C570	CC 10PF+-0,25 50V NPO 1206 CERAMIC CHIP CAPACITOR	CC 0099.8480.00	MURATA	GRM42-6COG 100 C5OPT	
C573	CC 12PF+-1% 50V NPO 1206 CERAMIC CHIP CAPACITOR	CC 0099.8744.00	MURATA	GRM42-6COG 120 F5OPT	
C575	CC 12PF+-1% 50V NPO 1206 CERAMIC CHIP CAPACITOR	CC 0099.8744.00	MURATA	GRM42-6COG 120 F5OPT	
C580	CC 12PF+-1% 50V NPO 1206 CERAMIC CHIP CAPACITOR	CC 0099.8744.00	MURATA	GRM42-6COG 120 F5OPT	
C582	CC 10PF+-0,25 50V NPO 1206 CERAMIC CHIP CAPACITOR	CC 0099.8480.00	MURATA	GRM42-6COG 100 C5OPT	
C584	CC 5,6PF+-0,25 50V NPO1206 CERAMIC CHIP CAPACITOR	CC 0007.8220.00	MURATA	GRM42-6COG 5R6 C5OPT	

MENP5

413 3PUA

AI

Datum Date

Schaltteilliste für Parts list for

Sachnummer Stock No.

Blatt-Nr. Page



ROHDE & SCHWARZ

14 16.09.97

EE AUSGANGSTEIL 1.04 GHZ

1062.6209.01 SA

3+

Kennz. Comp. No.	Benennung Designation	Sachnummer Stock No.	Hersteller Manufacturer	Bezeichnung Designation	enthalten in contained in
C585	CC 100NF+-10%50V X7R 1206 CERAMIC CHIP CAPACITOR	CC 0007.5237.00	PHILIPS_CO	2238 581 15649	
C600	CC 18PF+-1% 50V NPO 1206 CERAMIC CHIP CAPACITOR	CC 0099.8767.00	MURATA	GRM42-6COG 180F 50PT	
C601	CC 27NF+-10%50VX7R 1206 CERAMIC CHIP CAPACITOR	CC 0099.8473.00	PHILIPS_CO	2238 581 16633	
C602	CC 100PF+-1%50V NPO 1206 CERAMIC CHIP CAPACITOR	CC 0099.8415.00	MURATA	GRM42-6COG 101F 50PT	
C603	CC 18PF+-1% 50V NPO 1206 CERAMIC CHIP CAPACITOR	CC 0099.8767.00	MURATA	GRM42-6COG 180F 50PT	
C604	CC 10PF+-0,25 50VNPO 1206 CERAMIC CHIP CAPACITOR	CC 0099.8480.00	MURATA	GRM42-6COG 100 C50PT	
C605	CC 4,7PF+-0,25 50VNPO1206 CERAMIC CHIP CAPACITOR	CC 0007.8213.00	MURATA	GRM42-6COG 4R7C 50PT	
C606	CC 3,9PF+-0,25 50VNPO1206 CERAMIC CHIP CAPACITOR	CC 0007.8207.00	MURATA	GRM42-6COG 3R9 C50PT	
C607	CC 3,3PF+-0,25 50VNPO1206 CERAMIC CHIP CAPACITOR	CC 0007.8194.00	MURATA	GRM42-6COG 3R3 C50PT	
C608	CC 220PF+-1%50V NPO 1206 CERAMIC CHIP CAPACITOR	CC 0099.8850.00	PHILIPS_CO	2238 863 18221	
C609	CC 100NF+-10%50V X7R 1206 CERAMIC CHIP CAPACITOR	CC 0007.5237.00	PHILIPS_CO	2238 581 15649	
C610	CC 100NF+-10%50V X7R 1206 CERAMIC CHIP CAPACITOR	CC 0007.5237.00	PHILIPS_CO	2238 581 15649	
C611	CC 10PF+-0,25 50VNPO 1206 CERAMIC CHIP CAPACITOR	CC 0099.8480.00	MURATA	GRM42-6COG 100 C50PT	
C617	CC 3,9PF+-0,25 50VNPO1206 CERAMIC CHIP CAPACITOR	CC 0007.8207.00	MURATA	GRM42-6COG 3R9 C50PT	
C618	CC 6,8PF+-0,25 50VNPO1206 CERAMIC CHIP CAPACITOR	CC 0007.8236.00	MURATA	GRM42-6COG 6R8 C50PT	
C619	CC 6,8PF+-0,25 50VNPO1206 CERAMIC CHIP CAPACITOR	CC 0007.8236.00	MURATA	GRM42-6COG 6R8 C50PT	
C620	CC 3,9PF+-0,25 50VNPO1206 CERAMIC CHIP CAPACITOR	CC 0007.8207.00	MURATA	GRM42-6COG 3R9 C50PT	
C625	CC 10PF+-0,25 50VNPO 1206 CERAMIC CHIP CAPACITOR	CC 0099.8480.00	MURATA	GRM42-6COG 100 C50PT	
C627	CC 18PF+-1% 50V NPO 1206 CERAMIC CHIP CAPACITOR	CC 0099.8767.00	MURATA	GRM42-6COG 180F 50PT	
C628	CC 100NF+-10%50V X7R 1206 CERAMIC CHIP CAPACITOR	CC 0007.5237.00	PHILIPS_CO	2238 581 15649	
C629	CE 47UF +-10% 10V 7343 TANTALUM SMD-CAPACITOR	CE 0007.7300.00	SPRAGUE	293D X9 010 D2T	
C631	CC 100NF+-10%50V X7R 1206 CERAMIC CHIP CAPACITOR NICHT BESTUECKT NOT FITTED	CC 0007.5237.00	PHILIPS_CO	2238 581 15649	
C632	CC 47PF+-1%50V COG 1206 CERAMIC CHIP CAPACITOR	CC 0099.8496.00	MURATA	GRM42-6COG 470F 50PT	
C633	CC 100NF+-10%50V X7R 1206 CERAMIC CHIP CAPACITOR	CC 0007.5237.00	PHILIPS_CO	2238 581 15649	
C634	CE 10UF +-10% 25V 7343 TANTALUM SMD-CAPACITOR	CE 0007.7246.00	SPRAGUE	293D 106 X9 025 D2T	
C635	CC 100NF+-10%50V X7R 1206 CERAMIC CHIP CAPACITOR	CC 0007.5237.00	PHILIPS_CO	2238 581 15649	
C636	CE 10UF +-10% 25V 7343 TANTALUM SMD-CAPACITOR	CE 0007.7246.00	SPRAGUE	293D 106 X9 025 D2T	
C637	CE 10UF +-10% 25V 7343 TANTALUM SMD-CAPACITOR	CE 0007.7246.00	SPRAGUE	293D 106 X9 025 D2T	
C638	CC 100NF+-10%50V X7R 1206 CERAMIC CHIP CAPACITOR	CC 0007.5237.00	PHILIPS_CO	2238 581 15649	
C639	CC 100NF+-10%50V X7R 1206 CERAMIC CHIP CAPACITOR	CC 0007.5237.00	PHILIPS_CO	2238 581 15649	
C640	CC 4,7PF+-0,25 50VNPO1206 CERAMIC CHIP CAPACITOR NICHT BESTUECKT NOT FITTED	CC 0007.8213.00	MURATA	GRM42-6COG 4R7C 50PT	
C641	CC 47PF+-1%50V COG 1206 CERAMIC CHIP CAPACITOR	CC 0099.8496.00	MURATA	GRM42-6COG 470F 50PT	
C642	CC 68PF+-1%50V NPO 1206 CERAMIC CHIP CAPACITOR	CC 0099.8815.00	MURATA	GRM42-6COG 680F 50PT	
C643	CC 68PF+-1%50V NPO 1206 CERAMIC CHIP CAPACITOR	CC 0099.8815.00	MURATA	GRM42-6COG 680F 50PT	
C644	CC 4,7PF+-0,25 50VNPO1206 CERAMIC CHIP CAPACITOR NICHT BESTUECKT NOT FITTED	CC 0007.8213.00	MURATA	GRM42-6COG 4R7C 50PT	
C645	CC 47PF+-1%50V COG 1206 CERAMIC CHIP CAPACITOR	CC 0099.8496.00	MURATA	GRM42-6COG 470F 50PT	

Für diese Unterlage behalten wir uns alle Rechte vor.

MENP5	413 3PUA	ÄI	Datum Date	Schaltteilleiste für Parts list for	Sachnummer Stock No.	Blatt-Nr. Page
		14	16.09.97	EE AUSGANGSTEIL 1.04 GHZ	1062.6209.01 SA	4+

095.0028-0893

Für diese Unterlage behalten
wir uns alle Rechte vor.

Kennz. Comp. No.	Benennung Designation	Sachnummer Stock No.	Hersteller Manufacturer	Bezeichnung Designation	enthalten in contained in
C646	CC 8,2PF+-0,25 50VNPO1206 CERAMIC CHIP CAPACITOR	CC 0007.8242.00	MURATA	GRM42-6COG 8R2 C50PT	
C647	CC 12PF+-1% 50V NPO 1206 CERAMIC CHIP CAPACITOR	CC 0099.8744.00	MURATA	GRM42-6COG 120 F50PT	
C650 ..653	CC 100NF+-10%50V X7R 1206 CERAMIC CHIP CAPACITOR	CC 0007.5237.00	PHILIPS_CO	2238 581 15649	
C654	CC 10NF+-10%50V X7R 1206 CERAMIC CHIP CAPACITOR	CC 0099.8521.00	MURATA	GRM42-6X7R103K 50PT	
C656	CC 1NF+-1% 50V NPO 1206 SMD CERAMIC CAPACITOR	CC 0007.7398.00	PHILIPS_CO	2222 863 *8102	
C660 ..663	CC 100NF+-10%50V X7R 1206 CERAMIC CHIP CAPACITOR	CC 0007.5237.00	PHILIPS_CO	2238 581 15649	
C664	CC 12PF+-1% 50V NPO 1206 CERAMIC CHIP CAPACITOR	CC 0099.8744.00	MURATA	GRM42-6COG 120 F50PT	
C668	CC 10PF+-0,25 50VNPO 1206 CERAMIC CHIP CAPACITOR	CC 0099.8480.00	MURATA	GRM42-6COG 100 C50PT	
C670	CC 100NF+-10%50V X7R 1206 CERAMIC CHIP CAPACITOR	CC 0007.5237.00	PHILIPS_CO	2238 581 15649	
C671	CC 100NF+-10%50V X7R 1206 CERAMIC CHIP CAPACITOR	CC 0007.5237.00	PHILIPS_CO	2238 581 15649	
C700	CC 1PF+-0,25 50V NPO 1206 CERAMIC CHIP CAPACITOR	CC 0099.8667.00	PHILIPS_CO	2238 863 15108	
C701	CC 1NF+-1% 50V NPO 1206 SMD CERAMIC CAPACITOR	CC 0007.7398.00	PHILIPS_CO	2222 863 *8102	
C702	CC 1NF+-1% 50V NPO 1206 SMD CERAMIC CAPACITOR	CC 0007.7398.00	PHILIPS_CO	2222 863 *8102	
C705	CC 56PF+-1%50V NPO 1206 CERAMIC CHIP CAPACITOR	CC 0099.8809.00	MURATA	GRM42-6COG 560F 50PT	
C707	CC 220PF+-1%50V NPO 1206 CERAMIC CHIP CAPACITOR	CC 0099.8850.00	PHILIPS_CO	2238 863 18221	
C708	CC 82PF+-1%50V NPO 1206 CERAMIC CHIP CAPACITOR	CC 0099.8821.00	MURATA	GRM42-6COG 820F 50PT	
C709	CC 82PF+-1%50V NPO 1206 CERAMIC CHIP CAPACITOR	CC 0099.8821.00	MURATA	GRM42-6COG 820F 50PT	
C710	CC 1NF+-1% 50V NPO 1206 SMD CERAMIC CAPACITOR	CC 0007.7398.00	PHILIPS_CO	2222 863 *8102	
C714	CC 2,7PF+-0,25 50VNPO1206 CERAMIC CHIP CAPACITOR	CC 0007.8188.00	MURATA	GRM42-6COG 2R7 C50PT	
C715	CC 220PF+-1%50V NPO 1206 CERAMIC CHIP CAPACITOR	CC 0099.8850.00	PHILIPS_CO	2238 863 18221	
C720	CC 1NF+-1% 50V NPO 1206 SMD CERAMIC CAPACITOR	CC 0007.7398.00	PHILIPS_CO	2222 863 *8102	
C721	CC 82PF+-1%50V NPO 1206 CERAMIC CHIP CAPACITOR	CC 0099.8821.00	MURATA	GRM42-6COG 820F 50PT	
C723	CC 82PF+-1%50V NPO 1206 CERAMIC CHIP CAPACITOR	CC 0099.8821.00	MURATA	GRM42-6COG 820F 50PT	
C724	CC 220PF+-1%50V NPO 1206 CERAMIC CHIP CAPACITOR	CC 0099.8850.00	PHILIPS_CO	2238 863 18221	
C727	CC 1NF+-1% 50V NPO 1206 SMD CERAMIC CAPACITOR	CC 0007.7398.00	PHILIPS_CO	2222 863 *8102	
C732	CC 220PF+-1%50V NPO 1206 CERAMIC CHIP CAPACITOR	CC 0099.8850.00	PHILIPS_CO	2238 863 18221	
C734	CC 82PF+-1%50V NPO 1206 CERAMIC CHIP CAPACITOR	CC 0099.8821.00	MURATA	GRM42-6COG 820F 50PT	
C735	CC 1NF+-1% 50V NPO 1206 SMD CERAMIC CAPACITOR	CC 0007.7398.00	PHILIPS_CO	2222 863 *8102	
C736	CC 82PF+-1%50V NPO 1206 CERAMIC CHIP CAPACITOR	CC 0099.8821.00	MURATA	GRM42-6COG 820F 50PT	
C738	CC 47PF+-1%50V COG 1206 CERAMIC CHIP CAPACITOR	CC 0099.8496.00	MURATA	GRM42-6COG 470F 50PT	
C740	CC 220PF+-1%50V NPO 1206 CERAMIC CHIP CAPACITOR	CC 0099.8850.00	PHILIPS_CO	2238 863 18221	
C743	CC 220PF+-1%50V NPO 1206 CERAMIC CHIP CAPACITOR	CC 0099.8850.00	PHILIPS_CO	2238 863 18221	
C747	CC 100PF+-1%50V NPO 1206 CERAMIC CHIP CAPACITOR	CC 0099.8415.00	MURATA	GRM42-6COG 101F 50PT	
C748	CC 100PF+-1%50V NPO 1206 CERAMIC CHIP CAPACITOR	CC 0099.8415.00	MURATA	GRM42-6COG 101F 50PT	
C750	CC 1NF+-1% 50V NPO 1206 SMD CERAMIC CAPACITOR	CC 0007.7398.00	PHILIPS_CO	2222 863 *8102	
C751	CC 1NF+-1% 50V NPO 1206 SMD CERAMIC CAPACITOR	CC 0007.7398.00	PHILIPS_CO	2222 863 *8102	
C762	CC 1NF+-1% 50V NPO 1206 SMD CERAMIC CAPACITOR	CC 0007.7398.00	PHILIPS_CO	2222 863 *8102	
C800	CC 100NF+-10%50V X7R 1206 CERAMIC CHIP CAPACITOR	CC 0007.5237.00	PHILIPS_CO	2238 581 15649	
C801	CE 1UF +-10% 25V EIA3528 TANTALUM SMD-CAPACITOR	CE 0007.7217.00	SPRAGUE	293D 105 X9 025 B2T	

MENP5

413 3PUA

ÄI

Datum
Date

Schaltteilliste für
Parts list for

Sachnummer
Stock No.

Blatt-Nr.
Page



ROHDE & SCHWARZ

14

16.09.97

EE AUSGANGSTEIL 1.04 GHZ

1062.6209.01 SA

5+

Für diese Unterlage behalten wir uns alle Rechte vor.

Kennz. Comp. No.	Benennung Designation	Sachnummer Stock No.	Hersteller Manufacturer	Bezeichnung Designation	enthalten in contained in
C802	CC 1PF+-0,25 50V NPO 1206 CERAMIC CHIP CAPACITOR NICHT BESTUECKT NOT FITTED	CC 0099.8667.00	PHILIPS_CO	2238 863 15108	
C805	CC 2,7PF+-0,25 50V NPO1206 CERAMIC CHIP CAPACITOR NICHT BESTUECKT NOT FITTED	CC 0007.8188.00	MURATA	GRM42-6COG 2R7 C5OPT	
C806	CC 100NF+-10%50V X7R 1206 CERAMIC CHIP CAPACITOR	CC 0007.5237.00	PHILIPS_CO	2238 581 15649	
C807	CC 3,9PF+-0,25 50V NPO1206 CERAMIC CHIP CAPACITOR	CC 0007.8207.00	MURATA	GRM42-6COG 3R9 C5OPT	
C809	CE 10UF +-10% 25V 7343 TANTALUM SMD-CAPACITOR	CE 0007.7246.00	SPRAGUE	293D 106 X9 025 D2T	
C811	CE 100UF+-20%25V RDX9,5 ELECTROLYTIC CAPACITOR	0803.0580.00	MATSUSHITA	ECE-A1ESS-101	
C812	CC 1PF+-0,25 50V NPO 1206 CERAMIC CHIP CAPACITOR NICHT BESTUECKT NOT FITTED	CC 0099.8667.00	PHILIPS_CO	2238 863 15108	
C814	CC 15PF+-1% 50V NPO 1206 CERAMIC CHIP CAPACITOR	CC 0099.8750.00	MURATA	GRM42-6COG 150F 50PT	
C816	CC 1PF+-0,25 50V NPO 1206 CERAMIC CHIP CAPACITOR NICHT BESTUECKT NOT FITTED	CC 0099.8667.00	PHILIPS_CO	2238 863 15108	
C817	CC 6,8PF+-0,25 50V NPO1206 CERAMIC CHIP CAPACITOR NICHT BESTUECKT NOT FITTED	CC 0007.8236.00	MURATA	GRM42-6COG 6R8 C5OPT	
C818	CC 3,9PF+-0,25 50V NPO1206 CERAMIC CHIP CAPACITOR	CC 0007.8207.00	MURATA	GRM42-6COG 3R9 C5OPT	
C819	CC 100NF+-10%50V X7R 1206 CERAMIC CHIP CAPACITOR	CC 0007.5237.00	PHILIPS_CO	2238 581 15649	
C820	CE 10UF +-10% 25V 7343 TANTALUM SMD-CAPACITOR	CE 0007.7246.00	SPRAGUE	293D 106 X9 025 D2T	
C821	CE 100UF+-20%25V RDX9,5 ELECTROLYTIC CAPACITOR	0803.0580.00	MATSUSHITA	ECE-A1ESS-101	
C822	CE 1UF +-10% 25V EIA3528 TANTALUM SMD-CAPACITOR	CE 0007.7217.00	SPRAGUE	293D 105 X9 025 B2T	
C824	CC 100NF+-10%50V X7R 1206 CERAMIC CHIP CAPACITOR	CC 0007.5237.00	PHILIPS_CO	2238 581 15649	
C828	CE 1UF +-10% 25V EIA3528 TANTALUM SMD-CAPACITOR	CE 0007.7217.00	SPRAGUE	293D 105 X9 025 B2T	
C829	CC 1PF+-0,25 50V NPO 1206 CERAMIC CHIP CAPACITOR NICHT BESTUECKT NOT FITTED	CC 0099.8667.00	PHILIPS_CO	2238 863 15108	
C830	CC 3,9PF+-0,25 50V NPO1206 CERAMIC CHIP CAPACITOR NICHT BESTUECKT NOT FITTED	CC 0007.8207.00	MURATA	GRM42-6COG 3R9 C5OPT	
C831	CC 3,9PF+-0,25 50V NPO1206 CERAMIC CHIP CAPACITOR	CC 0007.8207.00	MURATA	GRM42-6COG 3R9 C5OPT	
C832	CC 100NF+-10%50V X7R 1206 CERAMIC CHIP CAPACITOR	CC 0007.5237.00	PHILIPS_CO	2238 581 15649	
C833	CE 10UF +-10% 25V 7343 TANTALUM SMD-CAPACITOR	CE 0007.7246.00	SPRAGUE	293D 106 X9 025 D2T	
C834	CE 100UF+-20%25V RDX9,5 ELECTROLYTIC CAPACITOR	0803.0580.00	MATSUSHITA	ECE-A1ESS-101	
C836	CE 1UF +-10% 25V EIA3528 TANTALUM SMD-CAPACITOR	CE 0007.7217.00	SPRAGUE	293D 105 X9 025 B2T	
C839	CE 1UF +-10% 25V EIA3528 TANTALUM SMD-CAPACITOR	CE 0007.7217.00	SPRAGUE	293D 105 X9 025 B2T	
C840	CC 100NF+-10%50V X7R 1206 CERAMIC CHIP CAPACITOR	CC 0007.5237.00	PHILIPS_CO	2238 581 15649	
C844	CC 100PF+-1%50V NPO 1206 CERAMIC CHIP CAPACITOR	CC 0099.8415.00	MURATA	GRM42-6COG 101F 50PT	
C846	CC 100NF+-10%50V X7R 1206 CERAMIC CHIP CAPACITOR NICHT BESTUECKT NOT FITTED	CC 0007.5237.00	PHILIPS_CO	2238 581 15649	
C847	CC 47PF+-1%50V COG 1206 CERAMIC CHIP CAPACITOR	CC 0099.8496.00	MURATA	GRM42-6COG 470F 50PT	
C848	CC 10PF 0,25PF NPO 0805 CERAMIC CHIP CAPACITOR	CC 0099.8321.00	MURATA	GRM40 COG100C 50 PT	
C849	CC 1PF+-0,25 50V NPO 1206 CERAMIC CHIP CAPACITOR	CC 0099.8667.00	PHILIPS_CO	2238 863 15108	

MENP5	413 3PUA	ÄI	Datum Date	Schaltteilliste für Parts list for	Sachnummer Stock No.	Blatt-Nr. Page
	14	16.09.97	EE AUSGANGSTEIL 1.04 GHZ	1062.6209.01 SA	6+	

095.0026-0893

Für diese Unterlage behalten wir uns alle Rechte vor.

Kennz. Comp. No.	Benennung Designation	Sachnummer Stock No.	Hersteller Manufacturer	Bezeichnung Designation	enthalten in contained in
C850 .852	CC 100NF+-10%50V X7R 1206 CERAMIC CHIP CAPACITOR	CC 0007.5237.00	PHILIPS_CO	2238 581 15649	
C853	CC 1NF+-1% 50V NPO 1206 SMD CERAMIC CAPACITOR	CC 0007.7398.00	PHILIPS_CO	2222 863 *8102	
C854	CC 100NF+-10%50V X7R 1206 CERAMIC CHIP CAPACITOR	CC 0007.5237.00	PHILIPS_CO	2238 581 15649	
C855	CC 100NF+-10%50V X7R 1206 CERAMIC CHIP CAPACITOR	CC 0007.5237.00	PHILIPS_CO	2238 581 15649	
C860	CC 100NF+-10%50V X7R 1206 CERAMIC CHIP CAPACITOR	CC 0007.5237.00	PHILIPS_CO	2238 581 15649	
C870	CC 100NF+-10%50V X7R 1206 CERAMIC CHIP CAPACITOR	CC 0007.5237.00	PHILIPS_CO	2238 581 15649	
C871	CC 100NF+-10%50V X7R 1206 CERAMIC CHIP CAPACITOR	CC 0007.5237.00	PHILIPS_CO	2238 581 15649	
C880	CC 100NF+-10%50V X7R 1206 CERAMIC CHIP CAPACITOR	CC 0007.5237.00	PHILIPS_CO	2238 581 15649	
C881	CE 1UF +-10% 25V EIA3528 TANTALUM SMD-CAPACITOR	CE 0007.7217.00	SPRAGUE	293D 105 X9 025 B2T	
C883	CE 1UF +-10% 25V EIA3528 TANTALUM SMD-CAPACITOR	CE 0007.7217.00	SPRAGUE	293D 105 X9 025 B2T	
C885	CC 100NF+-10%50V X7R 1206 CERAMIC CHIP CAPACITOR	CC 0007.5237.00	PHILIPS_CO	2238 581 15649	
C886	CC 100NF+-10%50V X7R 1206 CERAMIC CHIP CAPACITOR	CC 0007.5237.00	PHILIPS_CO	2238 581 15649	
C887	CC 22PF+-1%50V NPO 1206 CERAMIC CHIP CAPACITOR	CC 0099.8396.00	MURATA	GRM42-6COG 220F 50PT	
C889	CC 100NF+-10%50V X7R 1206 CERAMIC CHIP CAPACITOR	CC 0007.5237.00	PHILIPS_CO	2238 581 15649	
D10	BL PC74HCT4051T 8CH.A.MUX ANALOG MULTIPLEXER	BL 0007.6827.00	PHILIPS	(PC)74HCT4051(T)	
D100	BL PC74HCT132T 4X2IN SCHM NAND SCHMITT TRIGGER	BL 0007.6340.00	PHILIPS	(PC)74HCT132(D/T)	
D102	BL PC74HC4094T 8ST.BUSREG BUS REGISTER	BL 0804.0977.00	PHILIPS_SE	(PC)74HC4094(D/T)	
D105	BL PC74HC08T 4X2IN.ANDG QUAD 2INPUT AND GATE	BL 0007.3486.00	PHILIPS_SE	(PC)74HC08(D/T)	
D110	BL PC74HC4094T 8ST.BUSREG BUS REGISTER	BL 0804.0977.00	PHILIPS_SE	(PC)74HC4094(D/T)	
D111	BL PC74HC08T 4X2IN.ANDG QUAD 2INPUT AND GATE	BL 0007.3486.00	PHILIPS_SE	(PC)74HC08(D/T)	
D115	BL PC74HC86T 4X2IN EXOR QUAD 2INPUT EXOR GATE	BL 0007.3511.00	PHILIPS_SE	(PC)74HC86(D/T)	
D120	BL PC74HC4094T 8ST.BUSREG BUS REGISTER	BL 0804.0977.00	PHILIPS_SE	(PC)74HC4094(D/T)	
D140	BJ DAC8143 1X12B-DAC 12B SERIAL D/A-CONVERTER	1012.9510.00	PMI	DAC8143FS	
D141	BS DG413DY 2A2R ANALOGSCH QUAD ANALOG CMOS.SWITCH	1004.7058.00	SILICONIX	DG413DY	
D145	BJ DAC8143 1X12B-DAC 12B SERIAL D/A-CONVERTER	1012.9510.00	PMI	DAC8143FS	
D150	BJ DAC8143 1X12B-DAC 12B SERIAL D/A-CONVERTER	1012.9510.00	PMI	DAC8143FS	
D200	BS DG413DY 2A2R ANALOGSCH QUAD ANALOG CMOS.SWITCH	1004.7058.00	SILICONIX	DG413DY	
D210	BS DG413DY 2A2R ANALOGSCH QUAD ANALOG CMOS.SWITCH	1004.7058.00	SILICONIX	DG413DY	
D220	BS DG413DY 2A2R ANALOGSCH QUAD ANALOG CMOS.SWITCH	1004.7058.00	SILICONIX	DG413DY	
D430	BL PC74HCT42T BCD/D. DEC DECODER	BL 0007.6240.00	PHILIPS	(PC)74HCT42(T)	
D431	BL PC74HCT04T 6XINVERT HEXINVERTER	BL 0007.5372.00	PHILIPS_SE	(PC)74HCT04(D/T)	
D432	BL PC74HCT04T 6XINVERT HEXINVERTER	BL 0007.5372.00	PHILIPS_SE	(PC)74HCT04(D/T)	
D760	BM SW-239 GAAS SPDTSWITCH GAAS RF-SWITCH	0853.5579.00	ANZAC	SW239	
L20	LD 10 UH 10% 3R3 144 MA CHOKER	LD 0026.4184.00	DALE	IM2	
L21	LD 470NH 10% 0,15A 1210 SMD-INDUCTOR	LD 0007.9926.00	SIEMENS	B82422-A3471-K100	
L22	LD 470NH 10% 0,15A 1210 SMD-INDUCTOR	LD 0007.9926.00	SIEMENS	B82422-A3471-K100	
L300	LD 220NH 10% 0,28A 1210 SMD-INDUCTOR	LD 0520.7911.00	SIEMENS	B82422-A3221-K100	
L301	LD 22NH 10% 0,60A 1210 SMD-INDUCTOR	1002.4897.00	SIEMENS	B82422-A3220-K100	

MENP5

413 3PUA

Ät

Datum

Date

Schaltteillista für

Parts list for

Sachnummer

Stock No.

Blatt-Nr.

Page



ROHDE & SCHWARZ

14

16.09.97

EE AUSGANGSTEIL 1.04 GHZ

1062.6209.01 SA

7+

Kennz. Comp. No.	Benennung Designation	Sachnummer Stock No.	Hersteller Manufacturer	Bezeichnung Designation	enthalten in contained in
L305	LD 1,00UH10%1,000HMO,390A CHOKE	LD 0067.2863.00	DALE	IM2	
L325	LD 1,00UH10%1,000HMO,390A CHOKE	LD 0067.2863.00	DALE	IM2	
L340	LD 1,00UH10%1,000HMO,390A CHOKE	LD 0067.2863.00	DALE	IM2	
L351	LD 1,00UH10%1,000HMO,390A CHOKE	LD 0067.2863.00	DALE	IM2	
L353	NICHT BESTUECKT NOT FITTED LD 1,00UH10%1,000HMO,390A CHOKE	LD 0067.2863.00	DALE	IM2	
L355	NICHT BESTUECKT NOT FITTED LD 22NH 10% 0,28A 1210 SMD-INDUCTOR	LD 0520.7911.00	SIEMENS	B82422-A3221-K100	
L360	LD 1,00UH10%1,000HMO,390A CHOKE	LD 0067.2863.00	DALE	IM2	
L361	LD 1,00UH10%1,000HMO,390A CHOKE	LD 0067.2863.00	DALE	IM2	
L400	LD 0,82UH10%0,850HMO,420A CHOKE	LD 0067.2857.00	DALE	IM2	
L410	LD 0,68UH10%0,600HMO,500A CHOKE	LD 0067.2840.00	DALE	IM2	
L416	LD 1,00UH10%1,000HMO,390A CHOKE	LD 0067.2863.00	DALE	IM2	
L417	LD 1,00UH10%1,000HMO,390A CHOKE	LD 0067.2863.00	DALE	IM2	
L431	LD 1UH 10% 0,38A 1210 SMD-INDUCTOR	LD 6006.0130.00	SIEMENS	B82422-A1102-K100	
L432	LD 1UH 10% 0,38A 1210 SMD-INDUCTOR	LD 6006.0130.00	SIEMENS	B82422-A1102-K100	
L500	LD 1,20UH10%0,180HMO,620A CHOKE	LD 0067.2870.00	DALE	IM2	
L505	LD 100NH 10% 0,080HM 1,4A CHOKE	LD 0067.2740.00	DALE	IM2	
L510	LD 0,33UH10%0,220HMO,830A CHOKE	LD 0067.2805.00	DALE	IM2	
L517	LD 0,15UH10%0,100HM1,230A CHOKE	LD 0067.2763.00	DALE	IM2	
L520	LD 0,82UH10%0,850HMO,420A CHOKE	LD 0067.2857.00	DALE	IM2	
L530	LD 3,30UH10%0,850HMO,285A CHOKE	LD 0067.2928.00	DALE	IM2	
L532	LD 22NH 10% 0,60A 1210 SMD-INDUCTOR	1002.4897.00	SIEMENS	B82422-A3220-K100	
..534					
L536	LD 3,30UH10%0,850HMO,285A CHOKE	LD 0067.2928.00	DALE	IM2	
L537	LD 22NH 10% 0,60A 1210 SMD-INDUCTOR	1002.4897.00	SIEMENS	B82422-A3220-K100	
L538	LD 47NH 10% 0,51A 1210 SMD-INDUCTOR	0008.5976.00	SIEMENS	B82422-A3470-K100	
L539	LD 47NH 10% 0,51A 1210 SMD-INDUCTOR	0008.5976.00	SIEMENS	B82422-A3470-K100	
L540	LD 22NH 10% 0,60A 1210 SMD-INDUCTOR	1002.4897.00	SIEMENS	B82422-A3220-K100	
..542					
L543	LD 3,30UH10%0,850HMO,285A CHOKE	LD 0067.2928.00	DALE	IM2	
L544	LD 22NH 10% 0,60A 1210 SMD-INDUCTOR	1002.4897.00	SIEMENS	B82422-A3220-K100	
L545	LD 47NH 10% 0,51A 1210 SMD-INDUCTOR	0008.5976.00	SIEMENS	B82422-A3470-K100	
..547					
L548	LD 22NH 10% 0,60A 1210 SMD-INDUCTOR	1002.4897.00	SIEMENS	B82422-A3220-K100	
..551					
L553	LD 3,30UH10%0,850HMO,285A CHOKE	LD 0067.2928.00	DALE	IM2	
L559	LD 22NH 10% 0,60A 1210 SMD-INDUCTOR	1002.4897.00	SIEMENS	B82422-A3220-K100	
L560	LD 47NH 10% 0,51A 1210 SMD-INDUCTOR	0008.5976.00	SIEMENS	B82422-A3470-K100	
L561	LD 22NH 10% 0,60A 1210 SMD-INDUCTOR	1002.4897.00	SIEMENS	B82422-A3220-K100	
L562	LD 100NH 10% 0,44A 1210 SMD-INDUCTOR	LD 0007.9249.00	SIEMENS	B82422-A3101-K100	
L563	LD 47NH 10% 0,51A 1210 SMD-INDUCTOR	0008.5976.00	SIEMENS	B82422-A3470-K100	
L564	LD 100NH 10% 0,44A 1210 SMD-INDUCTOR	LD 0007.9249.00	SIEMENS	B82422-A3101-K100	

Für diese Unteriage behalten
wir uns alle Rechte vor.

MENP5	413 3PUA	Äi	Datum Date	Schaltteilliste für Parts list for	Sachnummer Stock No.	Blatt-Nr. Page
	14	16.09.97	EE AUSGANGSTEIL 1.04 GHZ	1062.6209.01 SA	8+	

Für diese Unterlage behalten
wir uns alle Rechte vor.

Kennz. Comp. No.	Benennung Designation	Sachnummer Stock No.	Hersteller Manufacturer	Bezeichnung Designation	enthalten in contained in
L565	LD 47NH 10% 0,51A 1210 SMD-INDUCTOR	0008.5976.00	SIEMENS	B82422-A3470-K100	
L566	LD 47NH 10% 0,51A 1210 SMD-INDUCTOR	0008.5976.00	SIEMENS	B82422-A3470-K100	
L568	LD 3,30UH10%,850HMO,285A CHOKE	LD 0067.2928.00	DALE	IM2	
L570 .572	LD 22NH 10% 0,60A 1210 SMD-INDUCTOR	1002.4897.00	SIEMENS	B82422-A3220-K100	
L580	LD 22NH 10% 0,60A 1210 SMD-INDUCTOR	1002.4897.00	SIEMENS	B82422-A3220-K100	
L583	LD 22NH 10% 0,60A 1210 SMD-INDUCTOR	1002.4897.00	SIEMENS	B82422-A3220-K100	
L584	LD 22NH 10% 0,60A 1210 SMD-INDUCTOR	1002.4897.00	SIEMENS	B82422-A3220-K100	
L585	LD 1UH 10% 0,38A 1210 SMD-INDUCTOR	LD 6006.0130.00	SIEMENS	B82422-A1102-K100	
L600 .602	LD 1,00UH10%,000HMO,390A CHOKE	LD 0067.2863.00	DALE	IM2	
L604	LD 1UH 10% 0,38A 1210 SMD-INDUCTOR	LD 6006.0130.00	SIEMENS	B82422-A1102-K100	
L608	LD 12NH 10% 0,70A 1210 SMD-INDUCTOR	1002.4900.00	SIEMENS	B82422-A3120-K100	
L610	LD 12NH 10% 0,70A 1210 SMD-INDUCTOR	1002.4900.00	SIEMENS	B82422-A3120-K100	
L630	LD 47NH 10% 0,51A 1210 SMD-INDUCTOR	0008.5976.00	SIEMENS	B82422-A3470-K100	
L632	LD 22NH 10% 0,60A 1210 SMD-INDUCTOR	1002.4897.00	SIEMENS	B82422-A3220-K100	
L633	LD 22NH 10% 0,60A 1210 SMD-INDUCTOR	1002.4897.00	SIEMENS	B82422-A3220-K100	
L642	LD 1,00UH10%,000HMO,390A CHOKE	LD 0067.2863.00	DALE	IM2	
L643	LD 0,27UH10%,160HMO,975A CHOKE	LD 0067.2792.00	DALE	IM2	
L645	LD 0,15UH10%,100HM1,230A CHOKE	LD 0067.2763.00	DALE	IM2	
L647	LD 0,18UH10%,120HM1,120A CHOKE	LD 0067.2770.00	DALE	IM2	
L649	LD 0,15UH10%,100HM1,230A CHOKE	LD 0067.2763.00	DALE	IM2	
L650	LD 22NH 10% 0,60A 1210 SMD-INDUCTOR	1002.4897.00	SIEMENS	B82422-A3220-K100	
L651	LD 22NH 10% 0,60A 1210 SMD-INDUCTOR	1002.4897.00	SIEMENS	B82422-A3220-K100	
L660 .663	LD 1UH 10% 0,38A 1210 SMD-INDUCTOR	LD 6006.0130.00	SIEMENS	B82422-A1102-K100	
L668	LD 1UH 10% 0,38A 1210 SMD-INDUCTOR	LD 6006.0130.00	SIEMENS	B82422-A1102-K100	
L670	LD 1UH 10% 0,38A 1210 SMD-INDUCTOR	LD 6006.0130.00	SIEMENS	B82422-A1102-K100	
L671	LD 1UH 10% 0,38A 1210 SMD-INDUCTOR	LD 6006.0130.00	SIEMENS	B82422-A1102-K100	
L705	LD 220NH 10% 0,28A 1210 SMD-INDUCTOR	LD 0520.7911.00	SIEMENS	B82422-A3221-K100	
L706	LD 220NH 10% 0,28A 1210 SMD-INDUCTOR	LD 0520.7911.00	SIEMENS	B82422-A3221-K100	
L709	LD 4,7UH 10% 0,15A 1210 SMD-INDUCTOR	LD 0008.1687.00	SIEMENS	B82422-A1472-K100	
L714	LD 100NH 10% 0,44A 1210 SMD-INDUCTOR	LD 0007.9249.00	SIEMENS	B82422-A3101-K100	
L720	LD 4,7UH 10% 0,15A 1210 SMD-INDUCTOR	LD 0008.1687.00	SIEMENS	B82422-A1472-K100	
L727	LD 1UH 10% 0,38A 1210 SMD-INDUCTOR	LD 6006.0130.00	SIEMENS	B82422-A1102-K100	
L730	LD 100NH 10% 0,44A 1210 SMD-INDUCTOR	LD 0007.9249.00	SIEMENS	B82422-A3101-K100	
L732	LD 4,7UH 10% 0,15A 1210 SMD-INDUCTOR	LD 0008.1687.00	SIEMENS	B82422-A1472-K100	
L738	LD 100NH 10% 0,44A 1210 SMD-INDUCTOR	LD 0007.9249.00	SIEMENS	B82422-A3101-K100	
L739	LD 100NH 10% 0,44A 1210 SMD-INDUCTOR	LD 0007.9249.00	SIEMENS	B82422-A3101-K100	
L800	LD 12NH 10% 0,70A 1210 SMD-INDUCTOR	1002.4900.00	SIEMENS	B82422-A3120-K100	
L801	NICHT BESTUECKT NOT FITTED LD 1,20UH10%,180HMO,620A CHOKE	LD 0067.2870.00	DALE	IM2	

MENP5

413 3PUA

ÄI

Datum
Date

Schaltteilliste für
Parts list for

Sachnummer
Stock No.

Blatt-Nr.
Page



ROHDE & SCHWARZ

14

16.09.97

EE AUSGANGSTEIL 1.04 GHZ

1062.6209.01 SA

9+

wir uns alle Rechte vor.

Kennz. Comp. No.	Benennung Designation	Sachnummer Stock No.	Hersteller Manufacturer	Bezeichnung Designation	enthalten in contained in
L816	LD 12NH 10% 0,70A 1210 SMD-INDUCTOR	1002.4900.00	SIEMENS	B82422-A3120-K100	
L819	LD 220NH 10% 0,28A 1210 SMD-INDUCTOR	LD 0520.7911.00	SIEMENS	B82422-A3221-K100	
L828	LD 12NH 10% 0,70A 1210 SMD-INDUCTOR NICHT BESTUECKT NOT FITTED	1002.4900.00	SIEMENS	B82422-A3120-K100	
L830	LD 220NH 10% 0,28A 1210 SMD-INDUCTOR	LD 0520.7911.00	SIEMENS	B82422-A3221-K100	
L840	LD 1UH 10% 0,38A 1210 SMD-INDUCTOR	LD 6006.0130.00	SIEMENS	B82422-A1102-K100	
L841	LD 1UH 10% 0,38A 1210 SMD-INDUCTOR	LD 6006.0130.00	SIEMENS	B82422-A1102-K100	
L843	LD 47NH 10% 0,51A 1210 SMD-INDUCTOR NICHT BESTUECKT NOT FITTED	0008.5976.00	SIEMENS	B82422-A3470-K100	
L845	LD 100UH 10% 0,06A 1210 SMD-INDUCTOR	LD 0007.9261.00	SIEMENS	B82422-A1104-K100	
L880	LD 1,20UH10%, 180HMO, 620A CHOKE	LD 0067.2870.00	DALE	IM2	
L885	LD 1UH 10% 0,38A 1210 SMD-INDUCTOR	LD 6006.0130.00	SIEMENS	B82422-A1102-K100	
N20	BO TLO74ACD 4XFET OPAMP OPERATIONAL AMPLIFIER	0007.7823.00	TEXAS	TLO74A(CD)	
N130	BO NE5532D 2XLN OPAMP OPERATIONAL AMPLIFIER	0007.7798.00	SIGNETICS	NE5532D	
N223	BO TLO72ACD 2XFET OPAMP OPERATIONAL AMPLIFIER	0803.1057.00	TEXAS	TL 072 ACDR	
N228	BO TLO72ACD 2XFET OPAMP OPERATIONAL AMPLIFIER	0803.1057.00	TEXAS	TL 072 ACDR	
N235	BO NE5534D OPAMP OPERATIONAL AMPLIFIER	0815.7555.00	SIGNETICS	NE5534(D)	
N275	BO TLO72ACD 2XFET OPAMP OPERATIONAL AMPLIFIER	0803.1057.00	TEXAS	TL 072 ACDR	
N276	BO TLO72ACD 2XFET OPAMP OPERATIONAL AMPLIFIER	0803.1057.00	TEXAS	TL 072 ACDR	
N300	BM MSA0486 DC-3.2G MMIC BROADBAND AMPLIFIER NICHT BESTUECKT NOT FITTED	0846.4293.00	AVANTEK	MSA-0486	
N360	BM MSA1105 05-1.3G MMIC IC MICROWAVE MONOLITH AMP	1051.4051.00	AVANTEK	MSA-1105-TR1	
N410	BM MSA1105 05-1.3G MMIC IC MICROWAVE MONOLITH AMP	1051.4051.00	AVANTEK	MSA-1105-TR1	
N600	BO TLO74ACD 4XFET OPAMP OPERATIONAL AMPLIFIER	0007.7823.00	TEXAS	TLO74A(CD)	
N610	BO AD744KR FET OPAMP BIFET OPAMP	0854.1754.00	ANALOG_DEV	(AD)744KR	
N840	BO TLO74ACD 4XFET OPAMP OPERATIONAL AMPLIFIER	0007.7823.00	TEXAS	TLO74A(CD)	
N845	BO AD744KR FET OPAMP BIFET OPAMP	0854.1754.00	ANALOG_DEV	(AD)744KR	
P300	VL EINPRESSSTIFT L=6,8 PIN	VL 0010.7250.00	AMP	1-928776-5	
P305	VL EINPRESSSTIFT L=6,8 PIN	VL 0010.7250.00	AMP	1-928776-5	
P306	VL EINPRESSSTIFT L=6,8 PIN	VL 0010.7250.00	AMP	1-928776-5	
P352	VL EINPRESSSTIFT L=6,8 PIN	VL 0010.7250.00	AMP	1-928776-5	
P353	VL EINPRESSSTIFT L=6,8 PIN	VL 0010.7250.00	AMP	1-928776-5	
P375	VL EINPRESSSTIFT L=6,8 PIN	VL 0010.7250.00	AMP	1-928776-5	
P380	VL EINPRESSSTIFT L=6,8 PIN	VL 0010.7250.00	AMP	1-928776-5	
P385	VL EINPRESSSTIFT L=6,8 PIN	VL 0010.7250.00	AMP	1-928776-5	
P600	VL EINPRESSSTIFT L=6,8 PIN	VL 0010.7250.00	AMP	1-928776-5	
P601	VL EINPRESSSTIFT L=6,8 PIN	VL 0010.7250.00	AMP	1-928776-5	
P620	VL EINPRESSSTIFT L=6,8 PIN	VL 0010.7250.00	AMP	1-928776-5	

MENP5	413 3PUA	AI	Datum Date	Schaltteilliste für Parts list for	Sachnummer Stock No.	Blatt-Nr. Page
	14	16.09.97	EE AUSGANGSTEIL 1.04 GHZ	1062.6209.01 SA	10+	

095.0026-0893

Für diese Unterlage behalten wir uns alle Rechte vor.

Kannz. Comp. No.	Benennung Designation	Sachnummer Stock No.	Hersteller Manufacturer	Bezeichnung Designation	enthalten in contained in
P621	VL EINPRESSTIFT L=6,8 PIN	VL 0010.7250.00	AMP	1-928776-5	
P628	VL EINPRESSTIFT L=6,8 PIN	VL 0010.7250.00	AMP	1-928776-5	
P866	VL EINPRESSTIFT L=6,8 PIN	VL 0010.7250.00	AMP	1-928776-5	
R9	RG 10,0KOHM+-1%TK100 1206 RG CHIP RESISTOR	RG 0007.0793.00	ROEDERSTEI	DC2 10,0KOHM 1%TK100	
R10	RG 10,0KOHM+-1%TK100 1206 RG CHIP RESISTOR	RG 0007.0793.00	ROEDERSTEI	DC2 10,0KOHM 1%TK100	
R11	RG 182 KOHM+-1%TK100 1206 RESISTOR CHIP	RG 0007.5989.00	ROEDERSTEI	DC2 182KOHM 1%TK100	
R12	RG 121,0KOH+-1%TK100 1206 CHIP RESISTOR	RG 0007.1960.00	RESISTA	DC2 121KOHM 1% TK100	
R13	RG 121,0KOH+-1%TK100 1206 CHIP RESISTOR	RG 0007.1960.00	RESISTA	DC2 121KOHM 1% TK100	
R14	RG 56,2KOHM+-1%TK100 1206 CHIP RESISTOR	RG 0007.1883.00	ROEDERSTEI	DC2 56,2KOHM 1%TK100	
R15	RG 27,4KOHM+-1%TK100 1206 RESISTOR CHIP	RG 0007.5895.00	ROEDERSTEI	DC2 27,4KOHM 1%TK100	
R16	RG 1,0MOHM+-1%TK100 1206 CHIP RESISTOR	RG 0815.7532.00	DRALORIC	CRC 1206	
R17	RG 100 OHM+-1%TK100 1206 CHIP RESISTOR	RG 0006.8884.00	ROEDERSTEI	DC2 100OHM 1%TK100	
R18	RG 100 OHM+-1%TK100 1206 CHIP RESISTOR	RG 0006.8884.00	ROEDERSTEI	DC2 100OHM 1%TK100	
R20	RG 47,5 OHM+-1%TK100 1206 RESISTOR CHIP	RG 0007.5566.00	ROEDERSTEI	DC2 47,5OHM 1%TK100	
R21	RG 100 OHM+-1%TK100 1206 CHIP RESISTOR	RG 0006.8884.00	ROEDERSTEI	DC2 100OHM 1%TK100	
R22	RG 47,5 OHM+-1%TK100 1206 RESISTOR CHIP	RG 0007.5566.00	ROEDERSTEI	DC2 47,5OHM 1%TK100	
..25 R26	RG 10,0KOHM+-1%TK100 1206 RG CHIP RESISTOR	RG 0007.0793.00	ROEDERSTEI	DC2 10,0KOHM 1%TK100	
R27	RG 47,5 OHM+-1%TK100 1206 RESISTOR CHIP	RG 0007.5566.00	ROEDERSTEI	DC2 47,5OHM 1%TK100	
..32 R33	RG 100 OHM+-1%TK100 1206 CHIP RESISTOR	RG 0006.8884.00	ROEDERSTEI	DC2 100OHM 1%TK100	
R34	RG 100 OHM+-1%TK100 1206 CHIP RESISTOR	RG 0006.8884.00	ROEDERSTEI	DC2 100OHM 1%TK100	
R35	RG 2,0 KOHM+-1%TK100 1206 RESISTOR CHIP	RG 0007.5737.00	ROEDERSTEI	DC2 2,0KOHM 1%TK100	
R36	RG 100,0KOH+-1%TK100 1206 CHIP RESISTOR	RG 0007.1948.00	ROEDERSTEI	DC2 100KOHM 1%TK100	
R38	RG 10,0KOHM+-1%TK100 1206 RG CHIP RESISTOR	RG 0007.0793.00	ROEDERSTEI	DC2 10,0KOHM 1%TK100	
R41	RG 10,0KOHM+-1%TK100 1206 RG CHIP RESISTOR	RG 0007.0793.00	ROEDERSTEI	DC2 10,0KOHM 1%TK100	
..48 R50	RG 20,0KOHM+-1%TK100 1206 RESISTOR CHIP	RG 0007.5866.00	ROEDERSTEI	DC2 20,0KOHM 1%TK100	
..56 R116	RG 10,0KOHM+-1%TK100 1206 RG CHIP RESISTOR	RG 0007.0793.00	ROEDERSTEI	DC2 10,0KOHM 1%TK100	
R119	RG 825 OHM+-1%TK100 1206 CHIP RESISTOR	RG 0006.7259.00	ROEDERSTEI	DC2 825OHM 1%TK100	
R120	RG 100,0KOH+-1%TK100 1206 CHIP RESISTOR	RG 0007.1948.00	ROEDERSTEI	DC2 100KOHM 1%TK100	
..122 R123	RG 10,0KOHM+-1%TK100 1206 RG CHIP RESISTOR	RG 0007.0793.00	ROEDERSTEI	DC2 10,0KOHM 1%TK100	
R124	RG 10,0KOHM+-1%TK100 1206 RG CHIP RESISTOR	RG 0007.0793.00	ROEDERSTEI	DC2 10,0KOHM 1%TK100	
R130	RG 10,0KOHM+-1%TK100 1206 RG CHIP RESISTOR	RG 0007.0793.00	ROEDERSTEI	DC2 10,0KOHM 1%TK100	
..132 R133	RG 0-OHM WIDERSTAND-CHIP RESISTOR CHIP 0-OHM	RG 0007.5108.00	DRALORIC	CR 1206	
R149	RG 10,0KOHM+-1%TK100 1206 RG CHIP RESISTOR	RG 0007.0793.00	ROEDERSTEI	DC2 10,0KOHM 1%TK100	
R160	RG 100,0KOH+-1%TK100 1206 CHIP RESISTOR	RG 0007.1948.00	ROEDERSTEI	DC2 100KOHM 1%TK100	
R161	RG 100,0KOH+-1%TK100 1206 CHIP RESISTOR	RG 0007.1948.00	ROEDERSTEI	DC2 100KOHM 1%TK100	
R162	RG 1,0 KO +-1%TK100 1206 CHIP RESISTOR	RG 0006.7271.00	ROEDERSTEI	DC2 1,0KOHM 1%TK100	
R163	RG 1,0 KO +-1%TK100 1206 CHIP RESISTOR	RG 0006.7271.00	ROEDERSTEI	DC2 1,0KOHM 1%TK100	
R165	RG 100,0KOH+-1%TK100 1206 CHIP RESISTOR	RG 0007.1948.00	ROEDERSTEI	DC2 100KOHM 1%TK100	

MENP5	413 3PUA	Ät	Datum Date	Schaltteilliste für Parts list for	Sachnummer Stock No.	Blatt-Nr. Page
	ROHDE & SCHWARZ	14	16.09.97	EE AUSGANGSTEIL 1.04 GHZ	1062.6209.01 SA	11+

095.0026-0893

Für diese Unterlage behalten wir uns alle Rechte vor.

Kennz. Comp. No.	Benennung Designation	Sachnummer Stock No.	Hersteller Manufacturer	Bezeichnung Designation	enthaltene in contained in
R166	RG 100,0KOHM+-1%TK100 1206 CHIP RESISTOR	RG 0007.1948.00	ROEDERSTEI	DC2 100KOHM 1%TK100	
R167	RG 1,0 KO +-1%TK100 1206 CHIP RESISTOR	RG 0006.7271.00	ROEDERSTEI	DC2 1,0KOHM 1%TK100	
R168	RG 1,0 KO +-1%TK100 1206 CHIP RESISTOR	RG 0006.7271.00	ROEDERSTEI	DC2 1,0KOHM 1%TK100	
R170	RG 100,0KOHM+-1%TK100 1206 CHIP RESISTOR	RG 0007.1948.00	ROEDERSTEI	DC2 100KOHM 1%TK100	
R171	RG 100,0KOHM+-1%TK100 1206 CHIP RESISTOR	RG 0007.1948.00	ROEDERSTEI	DC2 100KOHM 1%TK100	
R172	RG 1,0 KO +-1%TK100 1206 CHIP RESISTOR	RG 0006.7271.00	ROEDERSTEI	DC2 1,0KOHM 1%TK100	
R173	RG 1,0 KO +-1%TK100 1206 CHIP RESISTOR	RG 0006.7271.00	ROEDERSTEI	DC2 1,0KOHM 1%TK100	
R208	RG 9,09KOHM+-1%TK100 1206 CHIP RESISTOR	RG 0007.0787.00	ROEDERSTEI	DC2 9,09KOHM 1%TK100	
R209	RG 10,0KOHM+-1%TK100 1206 RG CHIP RESISTOR NICHT BESTUECKT NOT FITTED	RG 0007.0793.00	ROEDERSTEI	DC2 10,0KOHM 1%TK100	
R211	RG 3,01KOHM+-1%TK100 1206 RESISTOR CHIP NUR VAR/ONLY MOD: 02	RG 0007.5772.00	ROEDERSTEI	DC2 3,01KOHM 1%TK100	
R211	RG 3,01KOHM+-1%TK100 1206 RESISTOR CHIP NUR VAR/ONLY MOD: 04	RG 0007.5772.00	ROEDERSTEI	DC2 3,01KOHM 1%TK100	
R211	RG 2,21KOHM+-1%TK100 1206 RESISTOR CHIP NUR VAR/ONLY MOD: 03 06	RG 0007.5743.00	ROEDERSTEI	DC2 2,21KOHM 1%TK100	
R212	RG 10,0KOHM+-1%TK100 1206 RG CHIP RESISTOR	RG 0007.0793.00	ROEDERSTEI	DC2 10,0KOHM 1%TK100	
R213	RG 10,0KOHM+-1%TK100 1206 RG CHIP RESISTOR	RG 0007.0793.00	ROEDERSTEI	DC2 10,0KOHM 1%TK100	
R214	RG 3,32KOHM+-1%TK100 1206 RESISTOR CHIP	RG 0007.5789.00	ROEDERSTEI	DC2 3,32KOHM 1%TK100	
R215	RG 20,0KOHM+-1%TK100 1206 RESISTOR CHIP	RG 0007.5866.00	ROEDERSTEI	DC2 20,0KOHM 1%TK100	
R216	RG 20,0KOHM+-1%TK100 1206 RESISTOR CHIP NICHT BESTUECKT NOT FITTED	RG 0007.5866.00	ROEDERSTEI	DC2 20,0KOHM 1%TK100	
R218	RG 4,32KOHM+-1%TK100 1206 RESISTOR CHIP	RG 0007.5814.00	RESISTA	DC2 4,32KOHM 1%TK100	
R219	RG 10,0KOHM+-1%TK100 1206 RG CHIP RESISTOR NICHT BESTUECKT NOT FITTED	RG 0007.0793.00	ROEDERSTEI	DC2 10,0KOHM 1%TK100	
R221	RG 182 KOHM+-1%TK100 1206 RESISTOR CHIP NICHT BESTUECKT NOT FITTED	RG 0007.5989.00	ROEDERSTEI	DC2 182KOHM 1%TK100	
R222	RG 0-OHM WIDERSTAND-CHIP RESISTOR CHIP 0-OHM	RG 0007.5108.00	DRALORIC	CR 1206	
R223	RG 10,0KOHM+-1%TK100 1206 RG CHIP RESISTOR	RG 0007.0793.00	ROEDERSTEI	DC2 10,0KOHM 1%TK100	
R240	RG 10,0KOHM+-1%TK100 1206 RG CHIP RESISTOR	RG 0007.0793.00	ROEDERSTEI	DC2 10,0KOHM 1%TK100	
R241	RG 20,0KOHM+-1%TK100 1206 RESISTOR CHIP	RG 0007.5866.00	ROEDERSTEI	DC2 20,0KOHM 1%TK100	
R259	RG 221 KOHM+-1%TK100 1206 RESISTOR CHIP NUR VAR/ONLY MOD: 02	RG 0007.6004.00	ROEDERSTEI	DC2 221KOHM 1%TK100	
R259	RG 221 KOHM+-1%TK100 1206 RESISTOR CHIP NUR VAR/ONLY MOD: 04	RG 0007.6004.00	ROEDERSTEI	DC2 221KOHM 1%TK100	
R259	RG 56,2KOHM+-1%TK100 1206 CHIP RESISTOR NUR VAR/ONLY MOD: 03 06	RG 0007.1883.00	ROEDERSTEI	DC2 56,2KOHM 1%TK100	
R271	RG 10,0KOHM+-1%TK100 1206 RG CHIP RESISTOR	RG 0007.0793.00	ROEDERSTEI	DC2 10,0KOHM 1%TK100	
R272	RG 10,0KOHM+-1%TK100 1206 RG CHIP RESISTOR	RG 0007.0793.00	ROEDERSTEI	DC2 10,0KOHM 1%TK100	
R275	RG 1,0 KO +-1%TK100 1206 CHIP RESISTOR	RG 0006.7271.00	ROEDERSTEI	DC2 1,0KOHM 1%TK100	
R276	RG 10,0KOHM+-1%TK100 1206 RG CHIP RESISTOR	RG 0007.0793.00	ROEDERSTEI	DC2 10,0KOHM 1%TK100	
R278	RG 47,5KOHM+-1%TK100 1206 RESISTOR CHIP NUR VAR/ONLY MOD: 02	RG 0007.5950.00	ROEDERSTEI	DC2 47,5KOHM 1%TK100	

MENP5	413 3PUA	AI	Datum Date	Schaltteilliste für Parts list for	Sachnummer Stock No.	Blatt-Nr. Page
	14	16.09.97	EE AUSGANGSTEIL 1.04 GHZ	1062.6209.01 SA	12+	

095.0028-0693

Für diese Unterlage behalten wir uns alle Rechte vor.

Kennz. Comp. No.	Benennung Designation	Sachnummer Stock No.	Hersteller Manufacturer	Bezeichnung Designation	enthalten in contained in
R278	RG 30,1KOHM+-1%TK100 1206 RESISTOR CHIP NUR VAR/ONLY MOD: 04	RG 0007.5908.00	ROEDERSTEI	DC2 30,1KOHM 1%TK100	
R278	RG 30,1KOHM+-1%TK100 1206 RESISTOR CHIP NUR VAR/ONLY MOD: 03 06	RG 0007.5908.00	ROEDERSTEI	DC2 30,1KOHM 1%TK100	
R280	RS 0,25W 5KOHM +-20% SMD POTENTIOMETER	RS 0007.9632.00	SIEMENS	S4G-5KOHM	
R283 .285	RG 20,0KOHM+-1%TK100 1206 RESISTOR CHIP	RG 0007.5866.00	ROEDERSTEI	DC2 20,0KOHM 1%TK100	
R286	RG 10,0KOHM+-1%TK100 1206 RG CHIP RESISTOR	RG 0007.0793.00	ROEDERSTEI	DC2 10,0KOHM 1%TK100	
R299	RG 33,2KOHM+-1%TK100 1206 RESISTOR CHIP NUR VAR/ONLY MOD: 02	RG 0007.5914.00	ROEDERSTEI	DC2 33,2KOHM 1%TK100	
R299	RG 33,2KOHM+-1%TK100 1206 RESISTOR CHIP NUR VAR/ONLY MOD: 04	RG 0007.5914.00	ROEDERSTEI	DC2 33,2KOHM 1%TK100	
R299	RG 15,0KOHM+-1%TK100 1206 RESISTOR CHIP NUR VAR/ONLY MOD: 03 06	RG 0007.5843.00	ROEDERSTEI	DC2 15,0KOHM 1%TK100	
R300	RG 0,05W 27R +-1% 0805 RESISTOR	RG 0007.8936.00	HONEST JAP	MR 08 M 27R 1% 0805	
R301 .308	RK SMD-HEISSEL.220R 0805 SMD-NTC-RESISTOR	1039.1310.00	SIEMENS	B57620-C221-K62	
R310	RG 68,1 OHM+-1%TK100 1206 CHIP RESISTOR	RG 0006.8849.00	ROEDERSTEI	DC2 68,1OHM 1%TK100	
R312	RG 12,1 OHM+-1%TK100 1206 CHIP RESISTOR	RG 0006.8661.00	ROEDERSTEI	DC2 12,1OHM 1%TK100	
R313	RG 56,2 OHM+-1%TK100 1206 CHIP RESISTOR	RG 0006.8826.00	ROEDERSTEI	DC2 56,2OHM 1%TK100	
R314	RG 511 OHM+-1%TK100 1206 CHIP RESISTOR	RG 0006.9051.00	ROEDERSTEI	DC2 511OHM 1%TK100	
R315	RL 0,60W 1,33KOHM+-1%TK50 RESISTOR	RL 0083.0684.00	RESISTA	MK2	
R316	RG 39,2 OHM+-1%TK100 1206 RESISTOR CHIP	RG 0007.5543.00	ROEDERSTEI	DC2 39,2OHM 1%TK100	
R317	RL 0,60W 1,33KOHM+-1%TK50 RESISTOR	RL 0083.0684.00	RESISTA	MK2	
R318	RL 0,60W 1,33KOHM+-1%TK50 RESISTOR	RL 0083.0684.00	RESISTA	MK2	
R319	RG 562 OHM+-1%TK100 1206 CHIP RESISTOR	RG 0006.9068.00	ROEDERSTEI	DC2 562OHM 1%TK100	
R320	RG 15,0 OHM+-1%TK100 1206 RESISTOR CHIP	RG 0007.5450.00	ROEDERSTEI	DC2 15,0OHM 1%TK100	
R321	RG 15,0 OHM+-1%TK100 1206 RESISTOR CHIP	RG 0007.5450.00	ROEDERSTEI	DC2 15,0OHM 1%TK100	
R325	RG 2,0 KOHM+-1%TK100 1206 RESISTOR CHIP	RG 0007.5737.00	ROEDERSTEI	DC2 2,0KOHM 1%TK100	
R327	RG 562 OHM+-1%TK100 1206 CHIP RESISTOR	RG 0006.9068.00	ROEDERSTEI	DC2 562OHM 1%TK100	
R328	RG 56,2 OHM+-1%TK100 1206 CHIP RESISTOR	RG 0006.8826.00	ROEDERSTEI	DC2 56,2OHM 1%TK100	
R329	RL 0,60W 1,33KOHM+-1%TK50 RESISTOR	RL 0083.0684.00	RESISTA	MK2	
R330	RG 15,0 OHM+-1%TK100 1206 RESISTOR CHIP	RG 0007.5450.00	ROEDERSTEI	DC2 15,0OHM 1%TK100	
R332	RL 0,60W 1,33KOHM+-1%TK50 RESISTOR	RL 0083.0684.00	RESISTA	MK2	
R333	RG 15,0 OHM+-1%TK100 1206 RESISTOR CHIP	RG 0007.5450.00	ROEDERSTEI	DC2 15,0OHM 1%TK100	
R340	RG 511 OHM+-1%TK100 1206 CHIP RESISTOR	RG 0006.9051.00	ROEDERSTEI	DC2 511OHM 1%TK100	
R341	RL 0,60W 1,33KOHM+-1%TK50 RESISTOR	RL 0083.0684.00	RESISTA	MK2	
R342	RG 39,2 OHM+-1%TK100 1206 RESISTOR CHIP	RG 0007.5543.00	ROEDERSTEI	DC2 39,2OHM 1%TK100	
R355	RG 0-OHM WIDERSTAND-CHIP RESISTOR CHIP 0-OHM	RG 0007.5108.00	DRALORIC	CR 1206	
R356	RL 0,60W 100 OHM+-1%TK50 RESISTOR	RL 0082.6543.00	RESISTA	MK2	
R357	RL 0,60W 100 OHM+-1%TK50 RESISTOR	RL 0082.6543.00	RESISTA	MK2	
R358	RG 0-OHM WIDERSTAND-CHIP RESISTOR CHIP 0-OHM NICHT BESTUECKT NOT FITTED	RG 0007.5108.00	DRALORIC	CR 1206	

MENP5

413 3PUA

Äi

Datum
Date

Schaltteilliste für
Parts list for

Sachnummer
Stock No.

Blatt-Nr.
Page



ROHDE & SCHWARZ

14

16.09.97

EE AUSGANGSTEIL 1.04 GHZ

1062.6209.01 SA

13+

095.0026-0893

Kennz. Comp. No.	Benennung Designation	Sachnummer Stock No.	Hersteller Manufacturer	Bezeichnung Designation	enthalten in contained in
R360	RL 0,60W 100 OHM+-1%TK50 RESISTOR	RL 0082.6543.00	RESISTA	MK2	
R361	RL 0,60W 100 OHM+-1%TK50 RESISTOR	RL 0082.6543.00	RESISTA	MK2	
R400	RG 511 OHM+-1%TK100 1206 CHIP RESISTOR	RG 0006.9051.00	ROEDERSTEI	DC2 511OHM 1%TK100	
R401	RL 0,60W 1,33KOHM+-1%TK50 RESISTOR	RL 0083.0684.00	RESISTA	MK2	
R402	RG 39,2 OHM+-1%TK100 1206 RESISTOR CHIP	RG 0007.5543.00	ROEDERSTEI	DC2 39,2OHM 1%TK100	
R404	RG 56,2 OHM+-1%TK100 1206 CHIP RESISTOR	RG 0006.8826.00	ROEDERSTEI	DC2 56,2OHM 1%TK100	
R405	RG 562 OHM+-1%TK100 1206 CHIP RESISTOR	RG 0006.9068.00	ROEDERSTEI	DC2 562OHM 1%TK100	
R406	RG 15,0 OHM+-1%TK100 1206 RESISTOR CHIP	RG 0007.5450.00	ROEDERSTEI	DC2 15,0OHM 1%TK100	
R407	RG 15,0 OHM+-1%TK100 1206 RESISTOR CHIP	RG 0007.5450.00	ROEDERSTEI	DC2 15,0OHM 1%TK100	
R408	RL 0,60W 1,33KOHM+-1%TK50 RESISTOR	RL 0083.0684.00	RESISTA	MK2	
R409	RL 0,60W 1,33KOHM+-1%TK50 RESISTOR	RL 0083.0684.00	RESISTA	MK2	
R410	RG 39,2KOHM+-1%TK100 1206 RESISTOR CHIP	RG 0007.5937.00	ROEDERSTEI	DC2 39,2KOHM 1%TK100	
R411	RG 1,5 KOHM+-1%TK100 1206 RESISTOR CHIP	RG 0007.5714.00	ROEDERSTEI	DC2 1,5KOHM 1%TK100	
R412	RG 1,0 KO +-1%TK100 1206 CHIP RESISTOR	RG 0006.7271.00	ROEDERSTEI	DC2 1,0KOHM 1%TK100	
R416	RL 0,60W 100 OHM+-1%TK50 RESISTOR	RL 0082.6543.00	RESISTA	MK2	
R417	RL 0,60W 100 OHM+-1%TK50 RESISTOR	RL 0082.6543.00	RESISTA	MK2	
R431	RG 10,0KOHM+-1%TK100 1206 RG CHIP RESISTOR	RG 0007.0793.00	ROEDERSTEI	DC2 10,0KOHM 1%TK100	
..438	RG 10,0KOHM+-1%TK100 1206 RG CHIP RESISTOR	RG 0007.0793.00	ROEDERSTEI	DC2 10,0KOHM 1%TK100	
R440	RG 10,0KOHM+-1%TK100 1206 RG CHIP RESISTOR	RG 0007.0793.00	ROEDERSTEI	DC2 10,0KOHM 1%TK100	
R442	RG 10,0KOHM+-1%TK100 1206 RG CHIP RESISTOR	RG 0007.0793.00	ROEDERSTEI	DC2 10,0KOHM 1%TK100	
R443	RG 10,0KOHM+-1%TK100 1206 RG CHIP RESISTOR	RG 0007.0793.00	ROEDERSTEI	DC2 10,0KOHM 1%TK100	
R450	RG 100 OHM+-1%TK100 1206 CHIP RESISTOR	RG 0006.8884.00	ROEDERSTEI	DC2 100OHM 1%TK100	
R451	RG 150 OHM+-1%TK100 1206 RESISTOR CHIP	RG 0007.5589.00	ROEDERSTEI	DC2 150OHM 1%TK100	
R452	RG 182 OHM+-1%TK100 1206 RESISTOR CHIP	RG 0007.5595.00	ROEDERSTEI	DC2 182OHM 1%TK100	
R453	RG 150 OHM+-1%TK100 1206 RESISTOR CHIP	RG 0007.5589.00	ROEDERSTEI	DC2 150OHM 1%TK100	
R454	RG 100 OHM+-1%TK100 1206 CHIP RESISTOR	RG 0006.8884.00	ROEDERSTEI	DC2 100OHM 1%TK100	
R455	RG 56,2 OHM+-1%TK100 1206 CHIP RESISTOR	RG 0006.8826.00	ROEDERSTEI	DC2 56,2OHM 1%TK100	
R500	RG 2,0 KOHM+-1%TK100 1206 RESISTOR CHIP	RG 0007.5737.00	ROEDERSTEI	DC2 2,0KOHM 1%TK100	
..502	RG 392 OHM+-1%TK100 1206 RESISTOR CHIP	RG 0007.5672.00	ROEDERSTEI	DC2 392OHM 1%TK100	
R503	RG 392 OHM+-1%TK100 1206 RESISTOR CHIP	RG 0007.5672.00	ROEDERSTEI	DC2 392OHM 1%TK100	
R520	RG 1,21KOHM+-1%TK100 1206 CHIP RESISTOR	RG 0006.9968.00	ROEDERSTEI	DC2 1,21KOHM 1%TK100	
..522	RG 392 OHM+-1%TK100 1206 RESISTOR CHIP	RG 0007.5672.00	ROEDERSTEI	DC2 392OHM 1%TK100	
R530	RG 392 OHM+-1%TK100 1206 RESISTOR CHIP	RG 0007.5672.00	ROEDERSTEI	DC2 392OHM 1%TK100	
R600	RG 221 OHM+-1%TK100 1206 RESISTOR CHIP	RG 0007.5614.00	ROEDERSTEI	DC2 221OHM 1%TK100	
R601	RL 0,60W 274 OHM+-1%TK50 RESISTOR	RL 0083.0178.00	RESISTA	MK2	
R602	RG 27,4 OHM+-1%TK100 1206 RESISTOR CHIP	RG 0007.5508.00	ROEDERSTEI	DC2 27,4OHM 1%TK100	
R603	RG 33,2 OHM+-1%TK100 1206 RESISTOR CHIP	RG 0007.5520.00	ROEDERSTEI	DC2 33,2OHM 1%TK100	
R604	RG 68,1 OHM+-1%TK100 1206 CHIP RESISTOR	RG 0006.8849.00	ROEDERSTEI	DC2 68,1OHM 1%TK100	
R605	RG 15,0 OHM+-1%TK100 1206 RESISTOR CHIP	RG 0007.5450.00	ROEDERSTEI	DC2 15,0OHM 1%TK100	
R606	RG 2,74KOHM+-1%TK100 1206 RESISTOR CHIP	RG 0007.5766.00	ROEDERSTEI	DC2 2,74KOHM 1%TK100	
R607	RG 825 KOHM+-1%TK100 1206 RESISTOR CHIP	RG 0007.6133.00	ROEDERSTEI	DC2 825KOHM 1%TK100	
R608	RG 100 OHM+-1%TK100 1206 CHIP RESISTOR	RG 0006.8884.00	ROEDERSTEI	DC2 100OHM 1%TK100	

Für diese Unterlage behalten wir uns alle Rechte vor.

095.0026-0893

MENP5	413 3PUA	ÄI	Datum Date	Schaltteilliste für Parts list for	Sachnummer Stock No.	Blatt-Nr. Page
	14	16.09.97	EE AUSGANGSTEIL 1.04 GHZ	1062.6209.01 SA	14+	

Für diese Unterlage behalten
wir uns alle Rechte vor.

Kennz. Comp. No.	Benennung Designation	Sachnummer Stock No.	Hersteller Manufacturer	Bezeichnung Designation	enthalten in contained in
R609	RG 1,5 KOHM+-1%TK100 1206 RESISTOR CHIP	RG 0007.5714.00	ROEDERSTEI	DC2 1,5KOHM 1%TK100	
R611	RG 392 OHM+-1%TK100 1206 RESISTOR CHIP	RG 0007.5672.00	ROEDERSTEI	DC2 392OHM 1%TK100	
R612	RG 475 OHM+-1%TK100 1206 RESISTOR CHIP	RG 0007.5695.00	ROEDERSTEI	DC2 475OHM 1%TK100	
R613	RG 3,01KOHM+-1%TK100 1206 RESISTOR CHIP	RG 0007.5772.00	ROEDERSTEI	DC2 3,01KOHM 1%TK100	
R614	RG 2,74KOHM+-1%TK100 1206 RESISTOR CHIP	RG 0007.5766.00	ROEDERSTEI	DC2 2,74KOHM 1%TK100	
R615	RG 1,2MOHM+-5%TK200 1206 CHIP RESISTOR NICHT BESTUECKT NOT FITTED	0007.9949.00	ROEDERSTEI	D 25	
R616	RG 3,01KOHM+-1%TK100 1206 RESISTOR CHIP	RG 0007.5772.00	ROEDERSTEI	DC2 3,01KOHM 1%TK100	
R617	RG 1,2MOHM+-5%TK200 1206 CHIP RESISTOR NICHT BESTUECKT NOT FITTED	0007.9949.00	ROEDERSTEI	D 25	
R618	RG 100,0KOH+-1%TK100 1206 CHIP RESISTOR	RG 0007.1948.00	ROEDERSTEI	DC2 100KOHM 1%TK100	
R619	RS 0,25W 5KOHM +-20% SMD POTENTIOMETER	RS 0007.9632.00	SIEMENS	S4G-5KOHM	
R620	RG 100,0KOH+-1%TK100 1206 CHIP RESISTOR	RG 0007.1948.00	ROEDERSTEI	DC2 100KOHM 1%TK100	
R621	RG 475 OHM+-1%TK100 1206 RESISTOR CHIP	RG 0007.5695.00	ROEDERSTEI	DC2 475OHM 1%TK100	
R622	RG 100 OHM+-1%TK100 1206 CHIP RESISTOR	RG 0006.8884.00	ROEDERSTEI	DC2 100OHM 1%TK100	
R623	RK SMD-HEISSL.22OR 0805 SMD-NTC-RESISTOR NICHT BESTUECKT NOT FITTED	1039.1310.00	SIEMENS	B57620-C221-K62	
R624	RK SMD-HEISSL.22OR 0805 SMD-NTC-RESISTOR	1039.1310.00	SIEMENS	B57620-C221-K62	
R625	RG 18,2 OHM+-1%TK100 1206 RESISTOR CHIP	RG 0007.5466.00	ROEDERSTEI	DC2 18,2OHM 1%TK100	
R626	RG 100 OHM+-1%TK100 1206 CHIP RESISTOR	RG 0006.8884.00	ROEDERSTEI	DC2 100OHM 1%TK100	
R627	RG 56,2 OHM+-1%TK100 1206 CHIP RESISTOR	RG 0006.8826.00	ROEDERSTEI	DC2 56,2OHM 1%TK100	
R628	RG 100 OHM+-1%TK100 1206 CHIP RESISTOR	RG 0006.8884.00	ROEDERSTEI	DC2 100OHM 1%TK100	
R629	RG 100 OHM+-1%TK100 1206 CHIP RESISTOR	RG 0006.8884.00	ROEDERSTEI	DC2 100OHM 1%TK100	
R630	RG 825 OHM+-1%TK100 1206 CHIP RESISTOR	RG 0006.7259.00	ROEDERSTEI	DC2 825OHM 1%TK100	
R631	RG 825 OHM+-1%TK100 1206 CHIP RESISTOR	RG 0006.7259.00	ROEDERSTEI	DC2 825OHM 1%TK100	
R632	RG 0-OHM WIDERSTAND-CHIP RESISTOR CHIP 0-OHM	RG 0007.5108.00	DRALORIC	CR 1206	
R634	RG 5,62OHM+-1%TK100 1206 CHIP-RESISTOR	RG 0007.8442.00	PHILIPS	RC 02	
R635	RG 22,1KOHM+-1%TK100 1206 RESISTOR CHIP	RG 0007.5872.00	ROEDERSTEI	DC2 22,1KOHM 1%TK100	
R636	RG 10,0KOHM+-1%TK100 1206 RG CHIP RESISTOR	RG 0007.0793.00	ROEDERSTEI	DC2 10,0KOHM 1%TK100	
R637	RG 1,5 KOHM+-1%TK100 1206 RESISTOR CHIP	RG 0007.5714.00	ROEDERSTEI	DC2 1,5KOHM 1%TK100	
R638	RG 392 OHM+-1%TK100 1206 RESISTOR CHIP	RG 0007.5672.00	ROEDERSTEI	DC2 392OHM 1%TK100	
R639	RG 10,0KOHM+-1%TK100 1206 RG CHIP RESISTOR	RG 0007.0793.00	ROEDERSTEI	DC2 10,0KOHM 1%TK100	
R640	RG 0-OHM WIDERSTAND-CHIP RESISTOR CHIP 0-OHM	RG 0007.5108.00	DRALORIC	CR 1206	
R641	RG 15,0 OHM+-1%TK100 1206 RESISTOR CHIP	RG 0007.5450.00	ROEDERSTEI	DC2 15,0OHM 1%TK100	
R642	RG 51,1 OHM+-1%TK100 1206 CHIP RESISTOR	RG 0006.8810.00	RESISTA	DC2 51,1OHM 1%TK100	
R644	RG 475 OHM+-1%TK100 1206 RESISTOR CHIP	RG 0007.5695.00	ROEDERSTEI	DC2 475OHM 1%TK100	
R645	RS 0,25W200 OHM+-20% SMD POTENTIOMETER	RS 0007.9590.00	SIEMENS	S4G-200 OHM	
R646	RL 0,60W 182 OHM+-1%TK50 RESISTOR	RL 0083.0010.00	RESISTA	MK2	
R647	RL 0,60W 121 OHM+-1%TK50 RESISTOR	RL 0082.9859.00	RESISTA	MK2	

MENP5

413 3PUA

Ät

Datum
Date

Schaltteilliste für
Parts list for

Sachnummer
Stock No.

Blatt-Nr.
Page



ROHDE & SCHWARZ

14

16.09.97

EE AUSGANGSTEIL 1.04 GHZ

1062.6209.01 SA

15+

Für diese Unterlage behalten wir uns alle Rechte vor.

Kannz. Comp. No.	Benennung Designation	Sachnummer Stock No.	Hersteller Manufacturer	Bezeichnung Designation	enthalten in contained in
R648	RG 100 OHM+-1%TK100 CHIP RESISTOR	1206 RG 0006.8884.00	ROEDERSTEI	DC2 100OHM 1%TK100	
R649	RG 2,740HM+-1%TK100 CHIP-RESISTOR	1206 RG 0007.8365.00	PHILIPS	RC 02	
R650	RG 1,0MOHM+-1%TK100 CHIP RESISTOR	1206 RG 0815.7532.00	DRALORIC	CRC 1206	
R651	RG 681 KOHM+-1%TK100 RESISTOR CHIP	1206 RG 0007.6110.00	ROEDERSTEI	DC2 681KOHM 1%TK100	
R652	RG 68,1 OHM+-1%TK100 CHIP RESISTOR	1206 RG 0006.8849.00	ROEDERSTEI	DC2 68,1OHM 1%TK100	
R653	RG 56,2 OHM+-1%TK100 CHIP RESISTOR	1206 RG 0006.8826.00	ROEDERSTEI	DC2 56,2OHM 1%TK100	
R654	RG 56,2 OHM+-1%TK100 CHIP RESISTOR	1206 RG 0006.8826.00	ROEDERSTEI	DC2 56,2OHM 1%TK100	
R655	RG 2,210HM+-1%TK100 CHIP-RESISTOR	1206 RG 0007.8342.00	PHILIPS	RC 02	
R657	RG 10,0KOHM+-1%TK100 RG CHIP RESISTOR	1206 RG 0007.0793.00	ROEDERSTEI	DC2 10,0KOHM 1%TK100	
R658	RG 10,0KOHM+-1%TK100 RG CHIP RESISTOR	1206 RG 0007.0793.00	ROEDERSTEI	DC2 10,0KOHM 1%TK100	
R700	RG 82,5 OHM+-1%TK100 CHIP RESISTOR	1206 RG 0006.8861.00	ROEDERSTEI	DC2 82,5OHM 1%TK100	
R701	RG 1,0 KO +-1%TK100 CHIP RESISTOR	1206 RG 0006.7271.00	ROEDERSTEI	DC2 1,0KOHM 1%TK100	
R702	RG 475 KOHM+-1%TK100 RESISTOR CHIP	1206 RG 0007.6079.00	ROEDERSTEI	DC2 475KOHM 1%TK100	
R704	RG 1,0 KO +-1%TK100 CHIP RESISTOR	1206 RG 0006.7271.00	ROEDERSTEI	DC2 1,0KOHM 1%TK100	
R705	RG 1,0MOHM+-1%TK100 CHIP RESISTOR	1206 RG 0815.7532.00	DRALORIC	CRC 1206	
R706	RG 1,21KOHM+-1%TK100 CHIP RESISTOR	1206 RG 0006.9968.00	ROEDERSTEI	DC2 1,21KOHM 1%TK100	
R707	RG 1,21KOHM+-1%TK100 CHIP RESISTOR	1206 RG 0006.9968.00	ROEDERSTEI	DC2 1,21KOHM 1%TK100	
R709	RG 100 OHM+-1%TK100 CHIP RESISTOR	1206 RG 0006.8884.00	ROEDERSTEI	DC2 100OHM 1%TK100	
R710	RG 121 OHM+-1%TK100 CHIP RESISTOR	1206 RG 0006.8903.00	ROEDERSTEI	DC2 121OHM 1%TK100	
R720	RG 100 OHM+-1%TK100 CHIP RESISTOR	1206 RG 0006.8884.00	ROEDERSTEI	DC2 100OHM 1%TK100	
R721	RG 121 OHM+-1%TK100 CHIP RESISTOR	1206 RG 0006.8903.00	ROEDERSTEI	DC2 121OHM 1%TK100	
R723	RG 1,21KOHM+-1%TK100 CHIP RESISTOR	1206 RG 0006.9968.00	ROEDERSTEI	DC2 1,21KOHM 1%TK100	
R724	RG 1,21KOHM+-1%TK100 CHIP RESISTOR	1206 RG 0006.9968.00	ROEDERSTEI	DC2 1,21KOHM 1%TK100	
R730	RG 332 OHM+-1%TK100 RESISTOR CHIP	1206 RG 0007.5650.00	ROEDERSTEI	DC2 332OHM 1%TK100	
R731	RG 1,21KOHM+-1%TK100 CHIP RESISTOR	1206 RG 0006.9968.00	ROEDERSTEI	DC2 1,21KOHM 1%TK100	
R732	RG 1,21KOHM+-1%TK100 CHIP RESISTOR	1206 RG 0006.9968.00	ROEDERSTEI	DC2 1,21KOHM 1%TK100	
R734	RG 121 OHM+-1%TK100 CHIP RESISTOR	1206 RG 0006.8903.00	ROEDERSTEI	DC2 121OHM 1%TK100	
R735	RG 100 OHM+-1%TK100 CHIP RESISTOR	1206 RG 0006.8884.00	ROEDERSTEI	DC2 100OHM 1%TK100	
R745	RG 10,0KOHM+-1%TK100 RG CHIP RESISTOR	1206 RG 0007.0793.00	ROEDERSTEI	DC2 10,0KOHM 1%TK100	
R747	RG 8,25KOHM+-1%TK100 CHIP RESISTOR	1206 RG 0007.0770.00	ROEDERSTEI	DC2 8,25KOHM 1%TK100	
R748	RG 8,25KOHM+-1%TK100 CHIP RESISTOR	1206 RG 0007.0770.00	ROEDERSTEI	DC2 8,25KOHM 1%TK100	
R750	RG 332 OHM+-1%TK100 RESISTOR CHIP	1206 RG 0007.5650.00	ROEDERSTEI	DC2 332OHM 1%TK100	
R751	RG 332 OHM+-1%TK100 RESISTOR CHIP	1206 RG 0007.5650.00	ROEDERSTEI	DC2 332OHM 1%TK100	
R753	RG 475 OHM+-1%TK100 RESISTOR CHIP	1206 RG 0007.5695.00	ROEDERSTEI	DC2 475OHM 1%TK100	
R754	RG 475 OHM+-1%TK100 RESISTOR CHIP	1206 RG 0007.5695.00	ROEDERSTEI	DC2 475OHM 1%TK100	
R760	RG 10,0KOHM+-1%TK100 RG CHIP RESISTOR	1206 RG 0007.0793.00	ROEDERSTEI	DC2 10,0KOHM 1%TK100	
R761	RG 0-OHM WIDERSTAND-CHIP RESISTOR CHIP 0-OHM	1206 RG 0007.5108.00	DRALORIC	CR 1206	
R762	RG 47,5 OHM+-1%TK100 RESISTOR CHIP	1206 RG 0007.5566.00	ROEDERSTEI	DC2 47,5OHM 1%TK100	
R801	RG 0-OHM WIDERSTAND-CHIP RESISTOR CHIP 0-OHM	1206 RG 0007.5108.00	DRALORIC	CR 1206	

MENP5	413 3PUA	Ät	Datum Date	Schaltteilleiste für Parts list for	Sachnummer Stock No.	Blatt-Nr. Page
	14	16.09.97	EE AUSGANGSTEIL 1.04 GHZ	1062.6209.01 SA	16+	

095.0026-0893

Für diese Unterlage behalten wir uns alle Rechte vor.

Kennz. Comp. No.	Benennung Designation	Sachnummer Stock No.	Hersteller Manufacturer	Bezeichnung Designation	enthalten in contained in
R802	RG 47,5 OHM+-1%TK100 1206 RESISTOR CHIP NICHT BESTUECKT NOT FITTED	RG 0007.5566.00	ROEDERSTEI	DC2 47,5OHM 1%TK100	
R803	RG 3,32KOHM+-1%TK100 1206 RESISTOR CHIP	RG 0007.5789.00	ROEDERSTEI	DC2 3,32KOHM 1%TK100	
R804	RG 22,1 OHM+-1%TK100 1206 RESISTOR CHIP	RG 0007.5489.00	ROEDERSTEI	DC2 22,1OHM 1%TK100	
R806	RG 1,0 KO +-1%TK100 1206 CHIP RESISTOR	RG 0006.7271.00	ROEDERSTEI	DC2 1,0KOHM 1%TK100	
R807	RG 1,0 KO +-1%TK100 1206 CHIP RESISTOR	RG 0006.7271.00	ROEDERSTEI	DC2 1,0KOHM 1%TK100	
R808	RG 10,0KOHM+-1%TK100 1206 RG CHIP RESISTOR	RG 0007.0793.00	ROEDERSTEI	DC2 10,0KOHM 1%TK100	
R809	RG 562 OHM+-1%TK100 1206 CHIP RESISTOR	RG 0006.9068.00	ROEDERSTEI	DC2 562OHM 1%TK100	
R811	RG 8,25OHM+-1%TK100 1206 CHIP-RESISTOR	RG 0007.8488.00	PHILIPS	RC 02	
R812	RG 12,1 OHM+-1%TK100 1206 CHIP RESISTOR	RG 0006.8661.00	ROEDERSTEI	DC2 12,1OHM 1%TK100	
. . 815					
R816	RG 27,4 OHM+-1%TK100 1206 RESISTOR CHIP	RG 0007.5508.00	ROEDERSTEI	DC2 27,4OHM 1%TK100	
R817	RG 47,5 OHM+-1%TK100 1206 RESISTOR CHIP	RG 0007.5566.00	ROEDERSTEI	DC2 47,5OHM 1%TK100	
R819	RG 1,0 KO +-1%TK100 1206 CHIP RESISTOR	RG 0006.7271.00	ROEDERSTEI	DC2 1,0KOHM 1%TK100	
R820	RG 1,0 KO +-1%TK100 1206 CHIP RESISTOR	RG 0006.7271.00	ROEDERSTEI	DC2 1,0KOHM 1%TK100	
R821	RG 10,0KOHM+-1%TK100 1206 RG CHIP RESISTOR	RG 0007.0793.00	ROEDERSTEI	DC2 10,0KOHM 1%TK100	
R822	RG 562 OHM+-1%TK100 1206 CHIP RESISTOR	RG 0006.9068.00	ROEDERSTEI	DC2 562OHM 1%TK100	
R823	RG 6,81OHM+-1%TK100 1206 CHIP-RESISTOR	RG 0007.8465.00	PHILIPS	RC 02	
R824	RG 8,25OHM+-1%TK100 1206 CHIP-RESISTOR	RG 0007.8488.00	PHILIPS	RC 02	
. . 827					
R828	RG 150 OHM+-1%TK100 1206 RESISTOR CHIP NICHT BESTUECKT NOT FITTED	RG 0007.5589.00	ROEDERSTEI	DC2 150OHM 1%TK100	
R829	RG 182 OHM+-1%TK100 1206 RESISTOR CHIP	RG 0007.5595.00	ROEDERSTEI	DC2 182OHM 1%TK100	
R830	RG 1,0 KO +-1%TK100 1206 CHIP RESISTOR	RG 0006.7271.00	ROEDERSTEI	DC2 1,0KOHM 1%TK100	
R831	RG 1,0 KO +-1%TK100 1206 CHIP RESISTOR	RG 0006.7271.00	ROEDERSTEI	DC2 1,0KOHM 1%TK100	
R832	RG 10,0KOHM+-1%TK100 1206 RG CHIP RESISTOR	RG 0007.0793.00	ROEDERSTEI	DC2 10,0KOHM 1%TK100	
R833	RG 681 OHM+-1%TK100 1206 CHIP RESISTOR	RG 0006.9080.00	ROEDERSTEI	DC2 681OHM 1%TK100	
R834	RG 6,81OHM+-1%TK100 1206 CHIP-RESISTOR	RG 0007.8465.00	PHILIPS	RC 02	
. . 838					
R839	RL 0,40W 270 OHM2% UNGEW. RESISTOR	RL 0092.6000.00	RESISTA	MK1 270OHM 2% UNGEW.	
R841	RG 100 OHM+-1%TK100 1206 CHIP RESISTOR NUR VAR/ONLY MOD: 02	RG 0006.8884.00	ROEDERSTEI	DC2 100OHM 1%TK100	
R841	RG 100 OHM+-1%TK100 1206 CHIP RESISTOR NUR VAR/ONLY MOD: 04	RG 0006.8884.00	ROEDERSTEI	DC2 100OHM 1%TK100	
R841	RG 100 OHM+-1%TK100 1206 CHIP RESISTOR NUR VAR/ONLY MOD: 03 06 NICHT BESTUECKT/NOT FITTED	RG 0006.8884.00	ROEDERSTEI	DC2 100OHM 1%TK100	
R842	RG 100 OHM+-1%TK100 1206 CHIP RESISTOR NUR VAR/ONLY MOD: 02	RG 0006.8884.00	ROEDERSTEI	DC2 100OHM 1%TK100	
R842	RG 100 OHM+-1%TK100 1206 CHIP RESISTOR NUR VAR/ONLY MOD: 04	RG 0006.8884.00	ROEDERSTEI	DC2 100OHM 1%TK100	
R842	RG 0-OHM WIDERSTAND-CHIP RESISTOR CHIP 0-OHM NUR VAR/ONLY MOD: 03 06	RG 0007.5108.00	DRALORIC	CR 1206	
R843	RG 182 OHM+-1%TK100 1206 RESISTOR CHIP NICHT BESTUECKT NOT FITTED	RG 0007.5595.00	ROEDERSTEI	DC2 182OHM 1%TK100	

MENP5

413 3PUA

AI

Datum
Date

14 16.09.97

Schalttailliste für
Parts list for

EE AUSGANGSTEIL 1.04 GHZ

Sachnummer
Stock No.

1062.6209.01 SA

Blatt-Nr.
Page

17+



ROHDE & SCHWARZ

095.0026-0693

Kennz. Comp. No.	Benennung Designation	Sachnummer Stock No.	Hersteller Manufacturer	Bezeichnung Designation	enthalten in contained in
R844	RG 3,92KOHM+-1%TK100 1206 RESISTOR CHIP	RG 0007.5808.00	RESISTA	DC2 3,92KOHM 1%TK100	
R845	RG 3,92KOHM+-1%TK100 1206 RESISTOR CHIP	RG 0007.5808.00	RESISTA	DC2 3,92KOHM 1%TK100	
R846	RG 100 OHM+-1%TK100 1206 CHIP RESISTOR	RG 0006.8884.00	ROEDERSTEI	DC2 100OHM 1%TK100	
R847	RG 2,210HM+-1%TK100 1206 CHIP-RESISTOR	RG 0007.8342.00	PHILIPS	RC 02	
R848	RG 681 OHM+-1%TK100 1206 CHIP RESISTOR	RG 0006.9080.00	ROEDERSTEI	DC2 681OHM 1%TK100	
R849	RG 0-OHM WIDERSTAND-CHIP RESISTOR CHIP 0-OHM	RG 0007.5108.00	DRALORIC	CR 1206	
R850	RG 100,0KOH+-1%TK100 1206 CHIP RESISTOR	RG 0007.1948.00	ROEDERSTEI	DC2 100KOHM 1%TK100	
R851	RS 0,25W 2KOHM +-20% SMD POTENTIOMETER	RS 0007.9626.00	SIEMENS	S4G-2KOHM	
R852	RG 100,0KOH+-1%TK100 1206 CHIP RESISTOR	RG 0007.1948.00	ROEDERSTEI	DC2 100KOHM 1%TK100	
R853	RG 10,0KOHM+-1%TK100 1206 RG CHIP RESISTOR	RG 0007.0793.00	ROEDERSTEI	DC2 10,0KOHM 1%TK100	
R854	RG 1,0MOHM+-1%TK100 1206 CHIP RESISTOR NICHT BESTUECKT NOT FITTED	RG 0815.7532.00	DRALORIC	CRC 1206	
R855	RG 3,92KOHM+-1%TK100 1206 RESISTOR CHIP	RG 0007.5808.00	RESISTA	DC2 3,92KOHM 1%TK100	
R856	RG 3,32KOHM+-1%TK100 1206 RESISTOR CHIP	RG 0007.5789.00	ROEDERSTEI	DC2 3,32KOHM 1%TK100	
R857	RG 3,92KOHM+-1%TK100 1206 RESISTOR CHIP	RG 0007.5808.00	RESISTA	DC2 3,92KOHM 1%TK100	
R858	RG 56,2 OHM+-1%TK100 1206 CHIP RESISTOR	RG 0006.8826.00	ROEDERSTEI	DC2 56,2OHM 1%TK100	
R859	RG 56,2 OHM+-1%TK100 1206 CHIP RESISTOR	RG 0006.8826.00	ROEDERSTEI	DC2 56,2OHM 1%TK100	
R860	RG 1,0MOHM+-1%TK100 1206 CHIP RESISTOR	RG 0815.7532.00	DRALORIC	CRC 1206	
R861	RG 475 OHM+-1%TK100 1206 RESISTOR CHIP	RG 0007.5695.00	ROEDERSTEI	DC2 475OHM 1%TK100	
R862	RG 8,25OHM+-1%TK100 1206 CHIP-RESISTOR	RG 0007.8488.00	PHILIPS	RC 02	
R863	RG 392 OHM+-1%TK100 1206 RESISTOR CHIP	RG 0007.5672.00	ROEDERSTEI	DC2 392OHM 1%TK100	
R864	RG 6,81OHM+-1%TK100 1206 CHIP-RESISTOR	RG 0007.8465.00	PHILIPS	RC 02	
R865	RG 6,81OHM+-1%TK100 1206 CHIP-RESISTOR	RG 0007.8465.00	PHILIPS	RC 02	
R866	RG 681 KOHM+-1%TK100 1206 RESISTOR CHIP	RG 0007.6110.00	ROEDERSTEI	DC2 681KOHM 1%TK100	
R867	RG 3,92KOHM+-1%TK100 1206 RESISTOR CHIP	RG 0007.5808.00	RESISTA	DC2 3,92KOHM 1%TK100	
R868	RG 121 OHM+-1%TK100 1206 CHIP RESISTOR	RG 0006.8903.00	ROEDERSTEI	DC2 121OHM 1%TK100	
R869	RG 825 KOHM+-1%TK100 1206 RESISTOR CHIP	RG 0007.6133.00	ROEDERSTEI	DC2 825KOHM 1%TK100	
R870	RG 22,1KOHM+-1%TK100 1206 RESISTOR CHIP	RG 0007.5872.00	ROEDERSTEI	DC2 22,1KOHM 1%TK100	
R871	RG 10,0KOHM+-1%TK100 1206 RG CHIP RESISTOR	RG 0007.0793.00	ROEDERSTEI	DC2 10,0KOHM 1%TK100	
R874	RG 1,5 KOHM+-1%TK100 1206 RESISTOR CHIP	RG 0007.5714.00	ROEDERSTEI	DC2 1,5KOHM 1%TK100	
R875	RG 392 OHM+-1%TK100 1206 RESISTOR CHIP	RG 0007.5672.00	ROEDERSTEI	DC2 392OHM 1%TK100	
R876	RG 82,5 OHM+-1%TK100 1206 CHIP RESISTOR	RG 0006.8861.00	ROEDERSTEI	DC2 82,5OHM 1%TK100	
R882	RG 82,5 OHM+-1%TK100 1206 CHIP RESISTOR	RG 0006.8861.00	ROEDERSTEI	DC2 82,5OHM 1%TK100	
R883	RG 68,1 OHM+-1%TK100 1206 CHIP RESISTOR	RG 0006.8849.00	ROEDERSTEI	DC2 68,1OHM 1%TK100	
R884	RL 0,40W 180 OHM2% UNGEW. RESISTOR	RL 0092.5985.00	RESISTA	MK1 180OHM 2% UNGEW.	
R889	RG 47,5 OHM+-1%TK100 1206 RESISTOR CHIP NICHT BESTUECKT NOT FITTED	RG 0007.5566.00	ROEDERSTEI	DC2 47,5OHM 1%TK100	
R899	RG 1,0MOHM+-1%TK100 1206 CHIP RESISTOR NICHT BESTUECKT NOT FITTED	RG 0815.7532.00	DRALORIC	CRC 1206	

Für diese Unterlage behalten
wir uns alle Rechte vor.

095.0026-0693

MENP5	413 3PUA	ÄI	Datum Date	Schaltteilliste für Parts list for	Sachnummer Stock No.	Blatt-Nr. Page
	14	16.09.97	EE AUSGANGSTEIL 1.04 GHZ	1062.6209.01 SA	18+	

Für diese Unterlage behalten wir uns alle Rechte vor.

Kennz. Comp. No.	Benennung Designation	Sachnummer Stock No.	Hersteller Manufacturer	Bezeichnung Designation	enthalten in contained in
U600	BM LRMS-2 MIXER 1GHZ HYBRID MIXER	1062.6273.00	MINI-CIRCU	LRMS-2	
V11	AD BAS32 75V UDI DIODE	AD 0006.7288.00	PHILIPS	BAS32 (L)	
V12	AD BAS32 75V UDI DIODE	AD 0006.7288.00	PHILIPS	BAS32 (L)	
V13	AK BCX70H N 45V 200MA TRANSISTOR	AK 0007.3105.00	VALVO	BCX 70 H	
V14	AD BAS32 75V UDI DIODE NICHT BESTUECKT NOT FITTED	AD 0006.7288.00	PHILIPS	BAS32 (L)	
V15	AD BAS32 75V UDI DIODE NICHT BESTUECKT NOT FITTED	AD 0006.7288.00	PHILIPS	BAS32 (L)	
V25	AD BAS32 75V UDI DIODE	AD 0006.7288.00	PHILIPS	BAS32 (L)	
V26	AD BAS32 75V UDI DIODE	AD 0006.7288.00	PHILIPS	BAS32 (L)	
V35	AE BZV55/C5V1 0.5W ZDI ZENER DIODE	AE 0006.9839.00	PHILIPS_SE	BZV55B5V1 (GEG)	
V110	AE 1N827 6,2V REF DI REFERENCE DIODE	AE 0418.0029.00	COMPENSATE	1N827(A)	
V130	AD BAV99 70V DUO UDI DIODE	AD 0911.0092.00	VALVO	BAV99	
V310	AE BAR61 3X(PI) 100V PIN PIN DIODE ARRAY (ATTENU.)	4001.5082.00	SIEMENS	BAR61(Q62702A120)	
V315	AE BAR61 3X(PI) 100V PIN PIN DIODE ARRAY (ATTENU.)	4001.5082.00	SIEMENS	BAR61(Q62702A120)	
V318	AD BAV99 70V DUO UDI DIODE	AD 0911.0092.00	VALVO	BAV99	
V319	AD BAV99 70V DUO UDI DIODE	AD 0911.0092.00	VALVO	BAV99	
V330	AD BAV99 70V DUO UDI DIODE	AD 0911.0092.00	VALVO	BAV99	
V333	AD BAV99 70V DUO UDI DIODE	AD 0911.0092.00	VALVO	BAV99	
V335 ..337	AD BAV99 70V DUO UDI DIODE	AD 0911.0092.00	VALVO	BAV99	
V400	AE BAR61 3X(PI) 100V PIN PIN DIODE ARRAY (ATTENU.)	4001.5082.00	SIEMENS	BAR61(Q62702A120)	
V404	AD BAV99 70V DUO UDI DIODE	AD 0911.0092.00	VALVO	BAV99	
V405	AD BAV99 70V DUO UDI DIODE	AD 0911.0092.00	VALVO	BAV99	
V411	AD BAS32 75V UDI DIODE	AD 0006.7288.00	PHILIPS	BAS32 (L)	
V431 ..438	AK BCX70H N 45V 200MA TRANSISTOR	AK 0007.3105.00	VALVO	BCX 70 H	
V500	AE BAR64-04 CA DOPPEL PIN DUAL PIN DIODE	1039.1327.00	SIEMENS	BAR6404 (Q62702-A101)	
V511	AE BAR64-04 CA DOPPEL PIN DUAL PIN DIODE	1039.1327.00	SIEMENS	BAR6404 (Q62702-A101)	
V512	AE BAR64-04 CA DOPPEL PIN DUAL PIN DIODE	1039.1327.00	SIEMENS	BAR6404 (Q62702-A101)	
V514 ..516	AE BAR64-04 CA DOPPEL PIN DUAL PIN DIODE	1039.1327.00	SIEMENS	BAR6404 (Q62702-A101)	
V520	AE BAR64-04 CA DOPPEL PIN DUAL PIN DIODE	1039.1327.00	SIEMENS	BAR6404 (Q62702-A101)	
V523	AE BAR64-04 CA DOPPEL PIN DUAL PIN DIODE	1039.1327.00	SIEMENS	BAR6404 (Q62702-A101)	
V530	AE BAR64-04 CA DOPPEL PIN DUAL PIN DIODE	1039.1327.00	SIEMENS	BAR6404 (Q62702-A101)	
V532	AE BAR64-04 CA DOPPEL PIN DUAL PIN DIODE	1039.1327.00	SIEMENS	BAR6404 (Q62702-A101)	
V535	AE BAR64-04 CA DOPPEL PIN DUAL PIN DIODE	1039.1327.00	SIEMENS	BAR6404 (Q62702-A101)	
V536	AE BAR64-04 CA DOPPEL PIN DUAL PIN DIODE	1039.1327.00	SIEMENS	BAR6404 (Q62702-A101)	
V539	AE BAR64-04 CA DOPPEL PIN DUAL PIN DIODE	1039.1327.00	SIEMENS	BAR6404 (Q62702-A101)	
V540	AE BAR64-04 CA DOPPEL PIN DUAL PIN DIODE	1039.1327.00	SIEMENS	BAR6404 (Q62702-A101)	
V543	AE BAR64-04 CA DOPPEL PIN DUAL PIN DIODE	1039.1327.00	SIEMENS	BAR6404 (Q62702-A101)	

MENP5	413 3PUA	ÄI	Datum Date	Schaltteilliste für Parts list for	Sachnummer Stock No.	Blatt-Nr. Page
		14	16.09.97	EE AUSGANGSTEIL 1.04 GHZ	1062.6209.01 SA	19+

095.0028-0693

Für diese Unterlage behalten wir uns alle Rechte vor.

Kennz. Comp. No.	Benennung Designation	Sachnummer Stock No.	Hersteller Manufacturer	Bezeichnung Designation	enthalten in contained in
V544	AE BAR64-04 CA DOPPEL PIN DUAL PIN DIODE	1039.1327.00	SIEMENS	BAR6404 (Q62702-A101)	
V548	AE BAR64-04 CA DOPPEL PIN DUAL PIN DIODE	1039.1327.00	SIEMENS	BAR6404 (Q62702-A101)	
V600	AE BZX55/B6V2 0,5W ZDI ZENER DIODE	AE 0012.2161.00	PHILIPS	BZX79B6V2	
V602	AK BFQ34T N 18V 150MA TRANSISTOR	0801.8283.00	PHILIPS	BFQ34T	
V604	AE HSMS2825 1+1 SCHOTTKY SCHOTTKY DIODE PAIR	1010.6214.00	HEWLETT_PA	HSMS2825 L31	
V606	AE HSMS2825 1+1 SCHOTTKY SCHOTTKY DIODE PAIR	1010.6214.00	HEWLETT_PA	HSMS2825 L31	
V608	AD BAS32 75V UDI DIODE	AD 0006.7288.00	PHILIPS	BAS32 (L)	
V610	AE BZV55/C5V1 0.5W ZDI ZENER DIODE	AE 0006.9839.00	PHILIPS_SE	BZV55B5V1 (GEG)	
V612	AK BFQ34T N 18V 150MA TRANSISTOR	0801.8283.00	PHILIPS	BFQ34T	
V635	AD BAS32 75V UDI DIODE	AD 0006.7288.00	PHILIPS	BAS32 (L)	
V636	AE 1N827 6,2V REF DI REFERENCE DIODE	AE 0418.0029.00	COMPENSATE	1N827(A)	
V650	AD BAS32 75V UDI DIODE	AD 0006.7288.00	PHILIPS	BAS32 (L)	
V700	AE HSMS2825 1+1 SCHOTTKY SCHOTTKY DIODE PAIR	1010.6214.00	HEWLETT_PA	HSMS2825 L31	
V705	AE BAR64-04 CA DOPPEL PIN DUAL PIN DIODE	1039.1327.00	SIEMENS	BAR6404 (Q62702-A101)	
V707	AE BAR64-04 CA DOPPEL PIN DUAL PIN DIODE	1039.1327.00	SIEMENS	BAR6404 (Q62702-A101)	
V720	AE BAR64-04 CA DOPPEL PIN DUAL PIN DIODE	1039.1327.00	SIEMENS	BAR6404 (Q62702-A101)	
V725	AE BAR64-04 CA DOPPEL PIN DUAL PIN DIODE	1039.1327.00	SIEMENS	BAR6404 (Q62702-A101)	
V730	AE BAR64-04 CA DOPPEL PIN DUAL PIN DIODE	1039.1327.00	SIEMENS	BAR6404 (Q62702-A101)	
V735	AE BAR64-04 CA DOPPEL PIN DUAL PIN DIODE	1039.1327.00	SIEMENS	BAR6404 (Q62702-A101)	
V745	AE BZV55/C6V2 0,5W ZDI ZENER DIODE	AE 0006.9851.00	PHILIPS	BZV55B6V2	
V746	AE BZV55/C6V2 0,5W ZDI ZENER DIODE	AE 0006.9851.00	PHILIPS	BZV55B6V2	
V747	AD BAS32 75V UDI DIODE	AD 0006.7288.00	PHILIPS	BAS32 (L)	
V748	AD BAS32 75V UDI DIODE	AD 0006.7288.00	PHILIPS	BAS32 (L)	
V800	AD BAS32 75V UDI DIODE	AD 0006.7288.00	PHILIPS	BAS32 (L)	
V801	AK BCX71J P 45V 200MA TRANSISTOR	AK 0007.2096.00	VALVO	BCX71J GEGURTET	
V802	AK BFQ34T N 18V 150MA TRANSISTOR	0801.8283.00	PHILIPS	BFQ34T	
V815	AD BAS32 75V UDI DIODE	AD 0006.7288.00	PHILIPS	BAS32 (L)	
V816	AK BCX71J P 45V 200MA TRANSISTOR	AK 0007.2096.00	VALVO	BCX71J GEGURTET	
V817	AK BFQ34T N 18V 150MA TRANSISTOR	0801.8283.00	PHILIPS	BFQ34T	
V830	AD BAS32 75V UDI DIODE	AD 0006.7288.00	PHILIPS	BAS32 (L)	
V831	AK BCX71J P 45V 200MA TRANSISTOR	AK 0007.2096.00	VALVO	BCX71J GEGURTET	
V832	AK BFQ34T N 18V 150MA TRANSISTOR	0801.8283.00	PHILIPS	BFQ34T	
V844	AE HSMS2825 1+1 SCHOTTKY SCHOTTKY DIODE PAIR	1010.6214.00	HEWLETT_PA	HSMS2825 L31	
V850	AE HSMS2825 1+1 SCHOTTKY SCHOTTKY DIODE PAIR	1010.6214.00	HEWLETT_PA	HSMS2825 L31	
V851	AD BAS32 75V UDI DIODE	AD 0006.7288.00	PHILIPS	BAS32 (L)	
V857	AD BAS32 75V UDI DIODE	AD 0006.7288.00	PHILIPS	BAS32 (L)	
V870	AD BAS32 75V UDI DIODE	AD 0006.7288.00	PHILIPS	BAS32 (L)	
V871	AE 1N827 6,2V REF DI REFERENCE DIODE	AE 0418.0029.00	COMPENSATE	1N827(A)	

MENP5	413 3PUA	Äi	Datum Date	Schaltteilliste für Parts list for	Sachnummer Stock No.	Blatt-Nr. Page
	14	16.09.97	EE AUSGANGSTEIL 1.04 GHZ	1062.6209.01 SA	20+	

095.0028-0693

Für diese Unterlage behalten wir uns alle Rechte vor.

Kennz. Comp. No.	Benennung Designation	Sachnummer Stock No.	Hersteller Manufacturer	Bezeichnung Designation	enthalten in contained in
X2	FP STECKERLEISTE 32POL. CONNECTOR 32P.	FP 0008.5718.00	SIEMENS	V42254-B1200-B611	
X205	FP STIFTLISTE 4P.R2,54 PIN CONNECTOR	FP 0009.6147.00			
X224 . .226	FJ EINBAUWINKELST. SMC ANGLE CONNECTOR	FJ 0249.9684.00	ROSENBERGE	39S-205-400-D3	
Z1	LD SMD-T-FILTER 3,3NF SMD-FILTER	1039.1362.00	MURATA	NFM61R20T332T1	
Z2	LD SMD PI-FILTER 10GHZ SURFACE-MOUNT-FILTER NICHT BESTUECKT NOT FITTED	LD 0008.5901.00	OXLEY	SLT/P/22000/SM3	
Z3	LD SMD-T-FILTER 3,3NF SMD-FILTER	1039.1362.00	MURATA	NFM61R20T332T1	
Z4	LD SMD-T-FILTER 3,3NF SMD-FILTER	1039.1362.00	MURATA	NFM61R20T332T1	
Z5 . .9	LD SMD-T-FILTER 100PF SMD-FILTER	1039.1356.00	MURATA	NFM61ROOT101T1	
Z10	LD SMD-T-FILTER 3,3NF SMD-FILTER	1039.1362.00	MURATA	NFM61R20T332T1	
Z11	LD SMD-T-FILTER 100PF SMD-FILTER	1039.1356.00	MURATA	NFM61ROOT101T1	
Z20	LD SMD PI-FILTER 10GHZ SURFACE-MOUNT-FILTER	LD 0008.5901.00	OXLEY	SLT/P/22000/SM3	

095.0028-0693

MENP5	413 3PUA	Äi	Datum Date	Schaltteilliste für Parts list for	Sachnummer Stock No.	Blatt-Nr. Page
	ROHDE & SCHWARZ	14	16.09.97	EE AUSGANGSTEIL 1.04 GHZ	1062.6209.01 SA	21-

XY-Liste

XY List

Erklärung der Spaltenbezeichnungen:

- Part:** Bauelement-Kennzeichen.
- Side:** Leiterplatten-Seite, auf der sich das Bauelement befindet.
- X/Y:** Koordinaten (Millimeter) des Bauelementes auf der Leiterplatte bezogen auf den Nullpunkt.
- SQR, PG:** Planquadrat und Seite des Schaltbildes für das jeweilige Bauelement.

Explanation of column designations:

- Part:** Identification of instrument part.
- Side:** Side of the PC board on which instrument part is positioned.
- X/Y:** Coordinates (millimeter) of the component on the PC board in reference to zero point.
- SQR, PG:** Square and page of the diagram for the respective instrument part.

Service-Relevante Bauteile / Service-Relevant Components																	
Part	Side	X	Y	Sqr	Pg	Part	Side	X	Y	Sqr	Pg	Part	Side	X	Y	Sqr	Pg
P300	B	88	36	6C	3	P600	B	186	62	3C	7	R645	B	252	80	9D	7
P305	B	67	39	10C	3	P601	B	199	76	3C	7	X2A	B	189	11	2C	2
P306	B	57	21	10D	3	P620	B	222	72	4B	7	X2B	B	189	11		
P352	B	59	21	11D	3	P621	B	223	70	4A	7	X205	B	69	40	10B	3
P353	B	53	20	12E	3	P628	B	177	64	4C	7	X224	B	17	15	1D	4
P375	B	153	37	2D	3	P866	B	293	16	8B	9	X225	B	258	15	5B	7
P380	B	114	41	4C	3	R280	B	123	42	3C	3	X226	B	283	15	11D	9
P385	B	104	53	5C	3	R619	B	198	79	2C	7						

Nicht-Service-Relevante Bauteile / Non-Service-Relevant Components																	
Part	Side	X	Y	Sqr	Pg	Part	Side	X	Y	Sqr	Pg	Part	Side	X	Y	Sqr	Pg
303	B	18	53	9D	4	C22	B	116	32	3E	2	C275	B	173	42	1D	3
309	B	30	71	10D	4	C132	B	229	36	9B	10	C280	B	105	46	3C	3
310	B	22	71	11D	4	C133	B	235	38	8B	10	C300	B	39	20	3D	4
413	B	50	69	5D	5	C149	A	215	43	3A	10	C302	B	24	27	4D	4
414	B	40	70	5D	5	C150	A	179	43	1A	10	C303	B	34	23	4D	4
506	B	81	83	3E	6	C151	A	164	51	2A	10	C313	B	45	29	5C	4
507	B	92	102	3D	6	C152	A	83	58	3A	10	C315	B	18	24	5D	4
509	B	92	83	4D	6	C153	B	123	60	6A	10	C316	B	22	34	6D	4
514	B	96	95	5D	6	C154	A	130	56	6A	10	C318	A	12	37	5C	4
515	B	111	95	5D	6	C156	A	203	43	4A	10	C319	A	15	41	6C	4
516	B	112	88	5D	6	C157	A	152	50	5A	10	C325	B	30	38	6D	4
518	B	123	89	6D	6	C160	A	130	42	6E	10	C327	B	17	48	6D	4
519	B	125	87	6D	6	C161	A	97	46	9E	10	C328	B	19	41	7D	4
520	B	135	95	7D	6	C162	A	76	22	10E	10	C329	A	39	41	7C	4
522	B	137	75	7E	6	C170	A	192	43	4A	10	C330	A	43	38	7C	4
528	B	148	82	8D	6	C209	A	86	43	6C	3	C340	B	45	50	8C	4
529	B	148	91	8D	6	C219	B	85	43	8C	3	C356	B	31	46	8D	4
542	B	46	98	2B	6	C220	A	54	39	9E	3	C357	B	31	53	9D	4
543	B	20	111	2B	6	C221	B	57	34	9D	3	C359	A	41	60	10E	4
544	B	23	116	3B	6	C223	B	79	46	8C	3	C360	B	31	67	10D	4
545	B	37	111	4B	6	C240	B	57	12	10E	3	C361	B	23	83	12D	4
548	B	76	132	6B	6	C242	B	66	16	11F	3	C362	A	48	86	12E	4
550	B	144	137	8B	6	C244	A	77	39	4A	3	C400	A	48	84	2C	5
600	B	178	70	2E	7	C245	A	72	49	4A	3	C401	B	42	81	3D	5
607	B	215	83	4D	7	C250	A	58	62	2A	3	C402	B	30	78	4D	5
608	B	208	86	5D	7	C251	A	64	62	2A	3	C404	A	34	88	3C	5
612	B	218	62	3D	7	C252	A	55	57	2A	3	C405	A	35	91	4C	5
660	B	218	62	3D	7	C253	A	59	51	2A	3	C410	A	42	76	5E	5
661	B	218	62	4D	7	C254	A	63	51	3A	3	C412	B	37	72	5D	5
705	B	150	122	2C	8	C255	A	55	47	3A	3	C417	A	70	70	7E	5
851	B	283	20	11D	9	C256	A	163	43	5A	3	C440	A	126	123	9B	5
C12	B	210	51	8C	2	C257	A	57	18	6A	3	C441	A	133	138	9B	5
C13	B	197	30	3E	2	C258	A	53	15	5A	3	C442	A	114	109	10B	5
C14	A	230	43	5A	2	C259	A	161	33	5A	3	C445	B	63	86	1C	6
C15	A	237	45	5A	2	C260	A	109	51	6A	3	C500	B	64	77	2E	6
C16	A	234	22	6A	2	C261	A	59	28	3A	3	C501	A	83	83	2F	6
C17	A	239	14	6A	2	C262	A	64	31	3A	3	C502	B	70	88	2D	6
C20	B	109	16	2D	2	C263	A	55	25	4A	3	C504	B	78	86	3D	6
C21	B	122	32	3E	2	C264	A	107	44	6A	3	C505	B	79	94	3E	6



ROHDE & SCHWARZ	-I	Datum Date	XY-Liste für XY-list for	Sach-Nummer Stock-Nr	Blatt Page
	04	11.07.96	EE AUSGANGSTEIL_1.046GHZ OUTPUT_UNIT_1.046GHZ	1062.6209.01 XY	1+

Part	Side	X	Y	Sqr	Pg	Part	Side	X	Y	Sqr	Pg	Part	Side	X	Y	Sqr	Pg
C851	A	296	74	7A	9	D200-A	B	57	55	5F	3	L510	B	114	86	6F	6
C852	A	280	75	6B	9	D200-B				5E	3	L517	B	137	91	7F	6
C853	A	291	68	6C	9	D200-C				5E	3	L520	B	147	119	9E	6
C854	A	292	34	8A	9	D200-D				5E	3	L530	B	56	93	2C	6
C855	A	280	38	8A	9	D200-E				1A	3	L532	B	55	98	2B	6
C858	B	253	133	2D	9	D210-A	B	57	42	7E	3	L533	B	20	101	2B	6
C860	A	297	47	9E	9	D210-B				7E	3	L534	B	40	103	3B	6
C870	A	296	79	11B	9	D210-C				7D	3	L536	B	81	109	3C	6
C871	A	300	66	11C	9	D210-D				7E	3	L537	B	57	115	4B	6
C880	A	279	140	8F	9	D210-E				2A	3	L538	B	45	116	4B	6
C881	B	289	95	6D	9	D220-A	B	57	23	10C	3	L539	B	52	122	5B	6
C883	B	289	125	3D	9	D220-B				7D	3	L540	B	35	118	4B	6
C885	A	152	131	2B	9	D220-C				7D	3	L541	B	61	119	5B	6
C886	A	155	138	3B	9	D220-D				10C	3	L542	B	64	123	5B	6
C887	B	289	113	4D	9	D220-E				3A	3	L543	B	89	119	5C	6
C889	A	294	114	4E	9	D430-A	A	120	111	9D	5	L544	B	44	134	7B	6
D10-A	B	230	18	7E	2	D430-B				8B	5	L545	B	72	129	6B	6
D10-B				6A	2	D431-A	A	109	111	10B	5	L546	B	45	129	6B	6
D100-A	B	213	41	8C	2	D431-B				10E	5	L547	B	55	134	7B	6
D100-B				9C	2	D431-C				10E	5	L548	B	52	129	6B	6
D100-C				10C	2	D431-D				10D	5	L549	B	82	130	7B	6
D100-D				6D	10	D431-E				10D	5	L550	B	26	129	6B	6
D100-E				3A	10	D431-F				10D	5	L551	B	33	137	7B	6
D102-A	B	177	41	2E	10	D431-G				10B	5	L553	B	89	135	7C	6
D102-B				1A	10	D432-A	A	130	128	10C	5	L559	B	97	135	8B	6
D105-A	B	190	41	3C	10	D432-B				10C	5	L560	B	105	138	8B	6
D105-B				3C	10	D432-C				10C	5	L561	B	118	137	9B	6
D105-C				8C	10	D432-D				11B	5	L562	B	124	137	9B	6
D105-D				7A	10	D432-E				11B	5	L563	B	141	133	9B	6
D105-E				3A	10	D432-F				10B	5	L564	B	121	130	9B	6
D110-A	B	161	54	4E	10	D432-G				9B	5	L565	B	102	128	9B	6
D110-B				2A	10	D760	B	236	132	10D	8	L566	B	141	128	9B	6
D111-A	A	146	52	6C	10	L20	B	124	15	2D	2	L568	B	87	114	10C	6
D111-B				6C	10	L21	A	105	16	2D	2	L570	B	99	110	10B	6
D111-C				6C	10	L22	B	96	28	3D	2	L571	B	108	117	11B	6
D111-D				6B	10	L300	B	27	23	4D	4	L572	B	117	119	11B	6
D111-E				4A	10	L301	B	45	23	3D	4	L580	B	124	119	11C	6
D115-A	B	201	41	4C	10	L305	B	39	32	5D	4	L583	B	133	117	11C	6
D115-B				7C	10	L325	B	17	39	6D	4	L584	B	141	110	11D	6
D115-C				3E	10	L340	B	39	44	8D	4	L585	A	99	74	2A	6
D115-D				7A	10	L350	B	23	67	10D	4	L600	B	175	86	2F	7
D115-E				4A	10	L351	B	23	67	10D	4	L601	B	180	82	2E	7
D120-A	B	79	55	7E	10	L353	B	41	53	10E	4	L602	B	171	67	2D	7
D120-B				2A	10	L355	B	34	50	9D	4	L604	A	171	64	4C	7
D140-A	B	137	39	6E	10	L360	B	19	89	11D	4	L608	B	218	73	4E	7
D140-B				2B	3	L361	B	55	86	11E	4	L610	B	220	82	5E	7
D141-A	B	144	44	5E	3	L380	B	20	89	12D	4	L630	B	257	69	7D	7
D141-B				1C	3	L400	B	30	83	2D	5	L632	B	266	69	8D	7
D141-C				1B	3	L410	B	46	76	4D	5	L633	B	243	70	7D	7
D141-D				5D	3	L416	B	72	73	6D	5	L642	B	268	100	9E	7
D141-E				4A	3	L417	B	62	70	6E	5	L643	B	239	77	9E	7
D145-A	B	94	39	8E	10	L431	A	97	89	11E	5	L645	B	213	98	10D	7
D145-B				5B	3	L432	A	118	90	11E	5	L647	B	204	107	11D	7
D150-A	B	74	15	10E	10	L500	B	81	77	2E	6	L649	B	218	107	11D	7
D150-B				9E	3	L505	B	94	89	4F	6	L650	B	224	110	11D	7

ROHDE & SCHWARZ	-I	Datum Date	XY-Liste für XY-list for	Sach-Nummer Stock-Nr	Blatt Page
	04	11.07.96	EE AUSGANGSTEIL_1.046GHZ OUTPUT_UNIT_1.046GHZ	1062.6209.01 XY	3+

Part	Side	X	Y	Sqr	Pg	Part	Side	X	Y	Sqr	Pg	Part	Side	X	Y	Sqr	Pg
L651	B	233	108	12D	7	N600-A	A	210	70	2C	7	R55	B	222	17	9E	2
L660	A	157	88	3F	7	N600-B				2A	7	R56	B	222	19	9E	2
L661	A	171	83	4F	7	N600-C				3B	7	R116	B	202	50	3F	10
L662	A	157	83	3E	7	N600-D				3A	7	R119	B	242	47	8B	10
L663	A	175	75	4E	7	N600-E				6A	7	R120	B	177	50	2F	10
L668	A	157	75	5F	7	N610-A	A	193	70	3C	7	R121	B	170	51	4E	10
L670	A	265	112	7F	7	N610-B				5A	7	R122	B	73	61	7E	10
L671	A	264	93	7F	7	N840-A	A	286	73	6B	9	R123	A	204	54	7A	10
L705	B	166	134	3C	8	N840-B				10B	9	R124	A	197	54	7A	10
L706	B	179	138	3C	8	N840-C				11B	9	R130	B	123	57	10D	10
L709	B	166	121	4C	8	N840-D				11C	9	R131	B	229	38	9B	10
L714	B	169	101	5C	8	N840-E				6A	9	R132	B	235	36	9B	10
L720	B	181	128	4D	8	N845-A	A	283	33	7B	9	R133	B	239	47	8B	10
L727	A	170	107	5E	8	N845-B				7A	9	R149	B	210	38	7C	10
L730	B	183	112	5D	8	R9	A	229	55	7D	2	R160	B	118	45	5E	10
L732	B	181	97	7C	8	R10	B	225	49	7C	2	R161	A	133	47	5E	10
L738	B	192	100	7D	8	R11	A	233	51	7D	2	R162	B	118	48	5E	10
L739	B	192	110	8D	8	R12	B	223	49	7C	2	R163	B	144	48	5E	10
L800	B	286	132	2D	9	R13	B	220	53	8C	2	R165	B	97	57	8E	10
L801	B	251	124	2F	9	R14	B	210	53	8B	2	R166	B	102	57	8E	10
L816	B	280	101	5D	9	R15	B	223	46	7C	2	R167	B	99	57	8E	10
L819	B	287	76	6E	9	R16	A	220	33	10C	2	R168	B	105	34	8E	10
L828	B	280	65	7D	9	R17	B	201	32	3F	2	R170	B	67	20	9E	10
L830	B	294	44	9E	9	R18	A	186	16	2F	2	R171	B	86	23	9E	10
L840	A	158	105	3B	9	R20	B	143	17	2D	2	R172	B	85	30	9E	10
L841	A	157	124	3A	9	R21	B	144	31	3D	2	R173	B	86	19	9E	10
L843	B	294	27	10D	9	R22	B	182	16	2C	2	R208	B	72	53	6E	3
L845	B	277	17	9B	9	R23	B	182	29	3C	2	R209	B	54	30	8D	3
L880	B	282	140	8F	9	R24	B	198	17	2C	2	R211	B	70	53	6E	3
L885	A	156	135	3B	9	R25	B	204	27	3C	2	R212	B	85	41	7C	3
N20-A	B	228	41	9B	10	R26	B	204	30	3C	2	R213	B	68	47	8D	3
N20-B				10B	10	R27	B	164	17	2C	2	R214	B	74	31	8E	3
N20-C				7D	2	R28	B	178	34	3C	2	R215	A	60	37	9E	3
N20-D				7C	2	R29	B	156	17	2B	2	R216	B	60	37	8E	3
N20-E				5A	2	R30	B	176	34	3B	2	R218	B	71	28	9D	3
N130-A	B	137	52	10D	10	R31	B	172	17	2B	2	R219	B	69	28	10C	3
N130-B				10C	10	R32	B	181	34	3B	2	R221	B	63	34	9D	3
N130-C				6A	10	R33	B	150	17	2A	2	R222	B	189	34	1D	3
N223-A	B	88	39	6C	3	R34	B	144	29	3A	2	R223	B	140	40	6D	3
N223-B				7B	3	R35	A	241	21	7A	2	R240	B	55	12	11E	3
N223-C				7A	3	R36	A	179	16	2C	2	R241	B	66	13	11E	3
N228-A	B	60	11	10E	3	R38	A	222	46	10C	2	R259	B	81	46	8C	3
N228-B				11E	3	R41	B	234	29	8E	2	R271	A	164	36	2D	3
N228-C				5A	3	R42	B	231	29	8E	2	R272	B	157	39	3D	3
N235-A	B	76	46	8C	3	R43	B	229	29	8E	2	R275	B	170	39	1C	3
N235-B				4A	3	R44	B	236	29	8E	2	R276	B	173	33	2D	3
N275-A	B	167	36	2D	3	R45	B	229	14	8E	2	R278	B	170	36	2D	3
N275-B				2D	3	R46	B	236	14	8E	2	R283	B	114	43	4B	3
N275-C				5A	3	R47	B	231	14	8E	2	R284	B	118	53	4C	3
N276-A	B	108	42	3C	3	R48	B	234	14	8E	2	R285	B	112	53	4C	3
N276-B				4B	3	R50	B	239	32	9E	2	R286	A	91	49	7B	3
N276-C				6A	3	R51	B	222	27	9E	2	R299	A	60	39	9E	3
N300	B	17	55	9D	4	R52	B	222	24	9E	2	R300	B	42	17	2D	4
N360	B	17	73	11D	4	R53	B	222	14	9E	2	R301	B	39	17	2D	4
N410	B	54	72	6D	5	R54	B	222	22	9E	2	R302	B	37	17	2D	4

ROHDE & SCHWARZ	-I	Datum Date	XY-Liste für XY-list for	Sach-Nummer Stock-Nr	Blatt Page
	04	11.07.96	EE AUSGANGSTEIL_1.046GHZ OUTPUT_UNIT_1.046GHZ	1062.6209.01 XY	4+

Part	Side	X	Y	Sqr	Pg	Part	Side	X	Y	Sqr	Pg	Part	Side	X	Y	Sqr	Pg
R303	B	34	17	2D	4	R440	A	144	130	10B	5	R641	B	269	69	8D	7
R304	B	32	17	2D	4	R442	A	133	108	11D	5	R642	B	243	67	7D	7
R305	B	29	17	2D	4	R443	A	67	113	11C	5	R644	B	264	88	8D	7
R306	B	27	17	3D	4	R450	A	140	95	11D	5	R646	B	249	79	9D	7
R307	B	24	17	3D	4	R451	A	60	102	11D	5	R647	B	241	81	9E	7
R308	B	22	17	3D	4	R452	A	88	109	11D	5	R648	A	241	88	9E	7
R310	B	42	23	3D	4	R453	A	95	119	11D	5	R649	B	247	98	9D	7
R312	B	37	20	3D	4	R454	A	95	135	11C	5	R650	A	190	81	2C	7
R313	A	18	28	5C	4	R455	A	81	114	11C	5	R651	A	187	79	2C	7
R314	B	41	32	5D	4	R500	A	80	83	2F	6	R652	B	184	78	2C	7
R315	B	46	36	4C	4	R501	A	77	83	2F	6	R653	A	206	82	1C	7
R316	B	45	27	5C	4	R502	A	75	83	2F	6	R654	A	202	79	1B	7
R317	B	12	44	5C	4	R503	B	75	83	3E	6	R655	B	245	101	9D	7
R318	B	15	44	6C	4	R520	A	145	113	9F	6	R657	A	221	80	3B	7
R319	A	21	34	6C	4	R521	A	143	113	9F	6	R658	A	223	75	3B	7
R320	A	15	30	5C	4	R522	A	148	113	9F	6	R700	B	154	111	2D	8
R321	A	20	37	6C	4	R530	B	69	93	2C	6	R701	B	154	121	2D	8
R325	B	34	41	6E	4	R600	B	164	79	2D	7	R702	B	153	124	3D	8
R327	A	21	48	7D	4	R601	B	178	82	2E	7	R704	A	150	126	2D	8
R328	A	23	41	7D	4	R602	A	184	79	2E	7	R705	A	141	121	2E	8
R329	B	46	41	6C	4	R603	A	181	75	2E	7	R706	B	169	128	4C	8
R330	A	21	50	7C	4	R604	B	189	72	2D	7	R707	B	169	118	4C	8
R332	B	46	38	7C	4	R605	B	164	73	2D	7	R709	A	166	114	3C	8
R333	A	26	44	7C	4	R606	A	213	67	2B	7	R710	A	168	120	4C	8
R340	B	41	44	8C	4	R607	A	193	83	3D	7	R720	A	179	139	3D	8
R341	B	43	53	8C	4	R608	B	192	74	2D	7	R721	A	178	130	4D	8
R342	B	44	47	8C	4	R609	B	187	82	2D	7	R723	B	183	132	4E	8
R355	B	17	56	9D	4	R611	A	180	64	4C	7	R724	B	183	123	4E	8
R356	B	38	59	10E	4	R612	A	178	67	4C	7	R730	B	177	112	5C	8
R357	B	36	57	10E	4	R613	A	197	66	3C	7	R731	B	183	102	6D	8
R358	B	17	74	11D	4	R614	A	194	78	3C	7	R732	B	183	93	7D	8
R360	B	42	89	11E	4	R615	A	197	77	3C	7	R734	A	177	97	6C	8
R361	B	55	89	11E	4	R616	A	203	69	2B	7	R735	A	182	105	6C	8
R400	B	45	81	2D	5	R617	A	213	62	2C	7	R745	B	213	140	9C	8
R401	B	55	84	2C	5	R618	A	194	86	2C	7	R747	A	227	133	10D	8
R402	B	48	79	2C	5	R620	A	196	81	2B	7	R748	A	234	125	10D	8
R404	A	37	84	4D	5	R621	B	231	80	5E	7	R750	A	220	129	10E	8
R405	A	28	82	4D	5	R622	B	186	69	3E	7	R751	A	222	123	10E	8
R406	A	33	81	4C	5	R623	B	231	77	6E	7	R753	A	210	134	10E	8
R407	A	29	91	4C	5	R624	B	231	74	6E	7	R754	A	215	123	10E	8
R408	B	42	86	3C	5	R625	B	231	72	6E	7	R760	B	228	121	10C	8
R409	B	32	91	4C	5	R626	B	228	69	6D	7	R761	B	236	109	10C	8
R410	A	42	74	4E	5	R627	B	230	66	6D	7	R762	A	182	113	7E	8
R411	A	44	69	4E	5	R628	B	230	64	6D	7	R801	B	241	134	2D	9
R412	A	37	68	4E	5	R629	B	186	67	3E	7	R802	B	296	129	2D	9
R416	B	85	73	6E	5	R630	B	264	24	5C	7	R803	A	288	60	5C	9
R417	B	75	70	6E	5	R631	B	264	15	5B	7	R804	B	278	132	3D	9
R431	A	99	101	10E	5	R632	B	241	64	6D	7	R806	B	281	124	3D	9
R432	A	129	113	10E	5	R634	B	264	21	5C	7	R807	A	268	125	3E	9
R433	A	131	102	10D	5	R635	A	206	72	2A	7	R808	A	258	118	3E	9
R434	A	71	105	10D	5	R636	A	206	74	2B	7	R809	A	248	121	3E	9
R435	A	103	112	10D	5	R637	A	213	85	3B	7	R811	A	258	121	4F	9
R436	A	112	122	10C	5	R638	A	213	83	3A	7	R812	B	298	114	4E	9
R437	A	108	135	10C	5	R639	A	217	83	3A	7	R813	B	297	107	4E	9
R438	A	71	119	10C	5	R640	B	258	46	6C	7	R814	B	294	107	4E	9

ROHDE & SCHWARZ	-I	Datum Date	XY-Liste für XY-list for	Sach-Nummer Stock-Nr	Blatt Page
	04	11.07.96	EE AUSGANGSTEIL_1.046GHZ OUTPUT_UNIT_1.046GHZ	1062.6209.01 XY	5+

Part	Side	X	Y	Sqr	Pg	Part	Side	X	Y	Sqr	Pg	Part	Side	X	Y	Sqr	Pg
R815	B	290	109	4E	9	R872	A	300	71	11B	9	V540	B	78	124	5B	6
R816	B	277	110	5D	9	R873	A	296	76	11B	9	V543	B	82	125	7B	6
R817	B	288	101	5D	9	R874	A	296	69	11C	9	V544	B	96	127	7B	6
R819	B	281	94	5D	9	R875	A	300	64	10C	9	V548	B	96	123	10B	6
R820	A	278	100	5E	9	R876	A	276	71	10B	9	V600	B	175	82	2E	7
R821	A	262	136	5E	9	R882	B	289	116	4E	9	V602	B	170	71	2D	7
R822	A	252	138	5E	9	R883	B	288	118	4E	9	V604-A	B	187	72	2D	7
R823	A	262	138	6F	9	R884	B	287	92	6E	9	V604-B				2D	7
R824	B	300	72	7E	9	R889	B	280	83	6D	9	V606-A	A	203	64	3C	7
R825	B	300	66	7E	9	R899	A	280	27	7B	9	V606-B				2B	7
R826	B	298	66	7E	9	U600	B	258	56	6D	7	V608	A	199	62	3C	7
R827	B	296	72	7E	9	V11	B	225	46	7C	2	V610	B	260	85	8D	7
R828	B	276	75	7D	9	V12	B	216	51	8C	2	V612	B	242	95	9D	7
R829	B	288	66	8D	9	V13	A	223	38	10C	2	V635	A	213	80	3A	7
R830	B	281	58	8D	9	V14	B	194	30	3F	2	V636	B	202	85	3A	7
R831	A	278	64	8E	9	V15	B	191	34	3E	2	V650	A	206	65	2B	7
R832	A	290	134	8E	9	V25	B	215	27	3C	2	V700-A	B	157	117	2D	8
R833	A	280	137	8E	9	V26	B	211	30	3C	2	V700-B				2D	8
R834	B	300	38	9E	9	V35	A	241	11	6A	2	V705	B	169	134	4C	8
R835	B	300	31	9E	9	V110	B	228	51	8B	10	V707	B	169	104	5C	8
R836	B	297	29	9E	9	V130	B	117	59	10C	10	V720	B	182	137	4D	8
R837	B	296	31	9E	9	V310	B	21	30	5D	4	V725	B	183	116	5E	8
R838	B	296	38	9E	9	V315	B	21	44	7D	4	V730	B	181	109	6D	8
R839	B	287	50	9E	9	V318	A	17	23	5C	4	V735	B	190	96	7D	8
R841	B	284	23	10D	9	V319	A	26	32	6C	4	V745	A	225	133	10D	8
R842	B	284	21	10D	9	V330	A	17	51	7C	4	V746	A	228	126	10D	8
R843	B	295	23	10D	9	V333	A	20	44	7C	4	V747	A	222	133	10D	8
R844	B	278	26	9C	9	V335	B	81	35	8C	3	V748	A	222	121	10D	8
R845	B	281	23	8B	9	V336	B	77	36	8C	3	V800	A	251	118	3E	9
R846	B	286	42	8C	9	V337	B	73	36	9C	3	V801	A	254	109	3E	9
R847	A	300	41	9E	9	V400	B	33	80	4D	5	V802	B	283	116	3D	9
R848	B	281	39	8C	9	V404	A	23	77	4C	5	V815	A	256	136	5E	9
R849	B	280	47	9D	9	V405	A	22	91	4C	5	V816	A	258	127	5E	9
R850	A	295	103	5B	9	V411	A	40	66	4E	5	V817	B	283	85	6D	9
R851	B	293	85	5B	9	V431	A	102	95	11E	5	V830	A	284	134	8E	9
R852	A	295	81	5B	9	V432	A	124	95	11E	5	V831	A	288	125	8E	9
R853	B	291	23	10D	9	V433	A	132	96	11D	5	V832	B	283	50	8D	9
R854	A	287	65	5B	9	V434	A	65	103	11D	5	V844-A	B	284	31	9C	9
R855	A	287	63	6B	9	V435	A	96	109	11D	5	V844-B				7C	9
R856	A	277	27	7B	9	V436	A	106	118	11C	5	V850-A	A	285	45	7B	9
R857	A	288	41	7B	9	V437	A	101	134	11C	5	V850-B				6B	9
R858	A	297	99	5B	9	V438	A	75	115	11C	5	V851	A	286	70	6C	9
R859	A	292	103	5B	9	V500	B	71	84	2E	6	V857	A	288	30	7B	9
R860	A	279	35	7C	9	V511	B	99	77	4E	6	V870	A	277	83	10B	9
R861	A	295	41	8B	9	V512	B	103	77	5E	6	V871	B	279	72	10B	9
R862	B	290	70	7E	9	V514	B	109	75	6E	6	Z1	B	118	20	2E	2
R863	A	295	44	8B	9	V515	B	123	77	6E	6	Z2	B	131	17	2D	2
R864	B	299	85	6E	9	V516	B	131	75	7E	6	Z3	B	100	20	2D	2
R865	A	290	137	9F	9	V520	B	144	101	9E	6	Z4	B	141	20	2D	2
R866	A	276	42	6C	9	V523	B	143	107	9D	6	Z5	B	184	20	2C	2
R867	B	277	29	7C	9	V530	B	67	87	1C	6	Z6	B	199	20	2C	2
R868	B	286	35	8C	9	V532	B	63	98	1B	6	Z7	B	169	20	2C	2
R869	A	282	45	8C	9	V535	B	63	105	3B	6	Z8	B	164	20	2B	2
R870	A	277	77	9B	9	V536	B	70	113	3B	6	Z9	B	174	20	2B	2
R871	A	278	80	10B	9	V539	B	72	121	5B	6	Z10	B	146	20	2A	2

ROHDE & SCHWARZ	-I	Datum Date	XY-Liste für XY-list for	Sach-Nummer Stock-Nr	Blatt Page
	04	11.07.96	EE AUSGANGSTEIL_1.046GHZ OUTPUT_UNIT_1.046GHZ	1062.6209.01 XY	6+

Part	Side	X	Y	Sqr	Pg	Part	Side	X	Y	Sqr	Pg	Part	Side	X	Y	Sqr	Pg
Z11	B	194	20	2F	2	Z20	B	126	17	2E	2						

ROHDE & SCHWARZ	-I	Datum Date	XY-Liste für XY-list for	Sach-Nummer Stock-Nr	Blatt Page
	04	11.07.96	EE AUSGANGSTEIL_1.046GHZ OUTPUT_UNIT_1.046GHZ	1062.6209.01 XY	7-

Stromläufe
Bestückungspläne
Circuit diagrams
Components plans
Schémas de circuit
Plans des composants

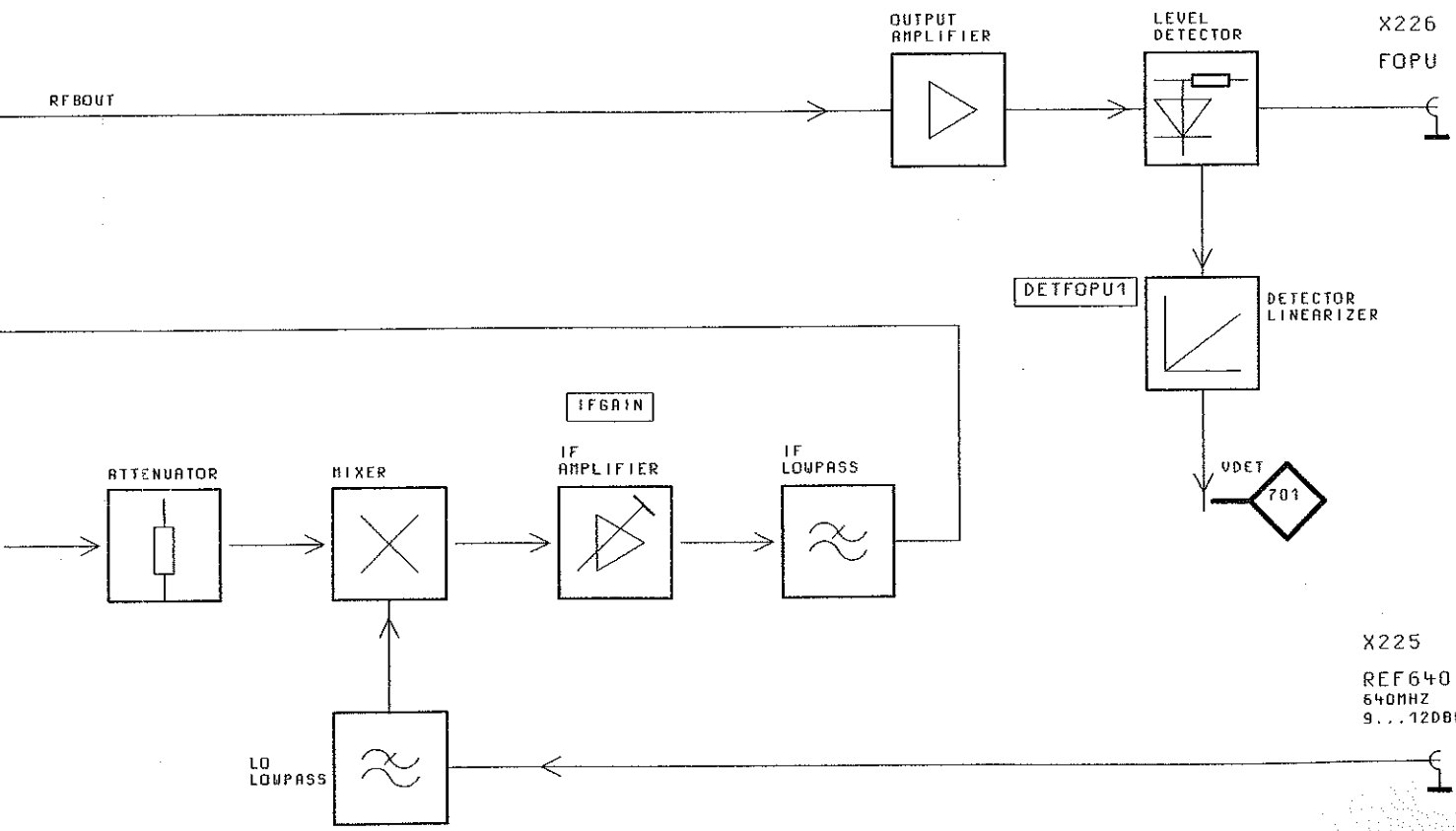

04/01		10.03.97	EI	MENP	TAG	NAME	BENENNUNG
				BEARB.		EI	AUSGANGSTEIL 1.046GHZ OUTPUT UNIT 1.046GHZ
				GEPR.			
				NORM			
				PLOTT	10.03.97		
04/		11.07.96	DR	 ROHDE&SCHWARZ			ZEICHN.-NR.
REND. IND.	RENDERUNGS- MITTEILUNG	DATUM	NAME				1062.6209.01S
				ZU GERÄT	SMY	REG.-I.V.	1062.5502
						ERSTE Z.	1062.5502

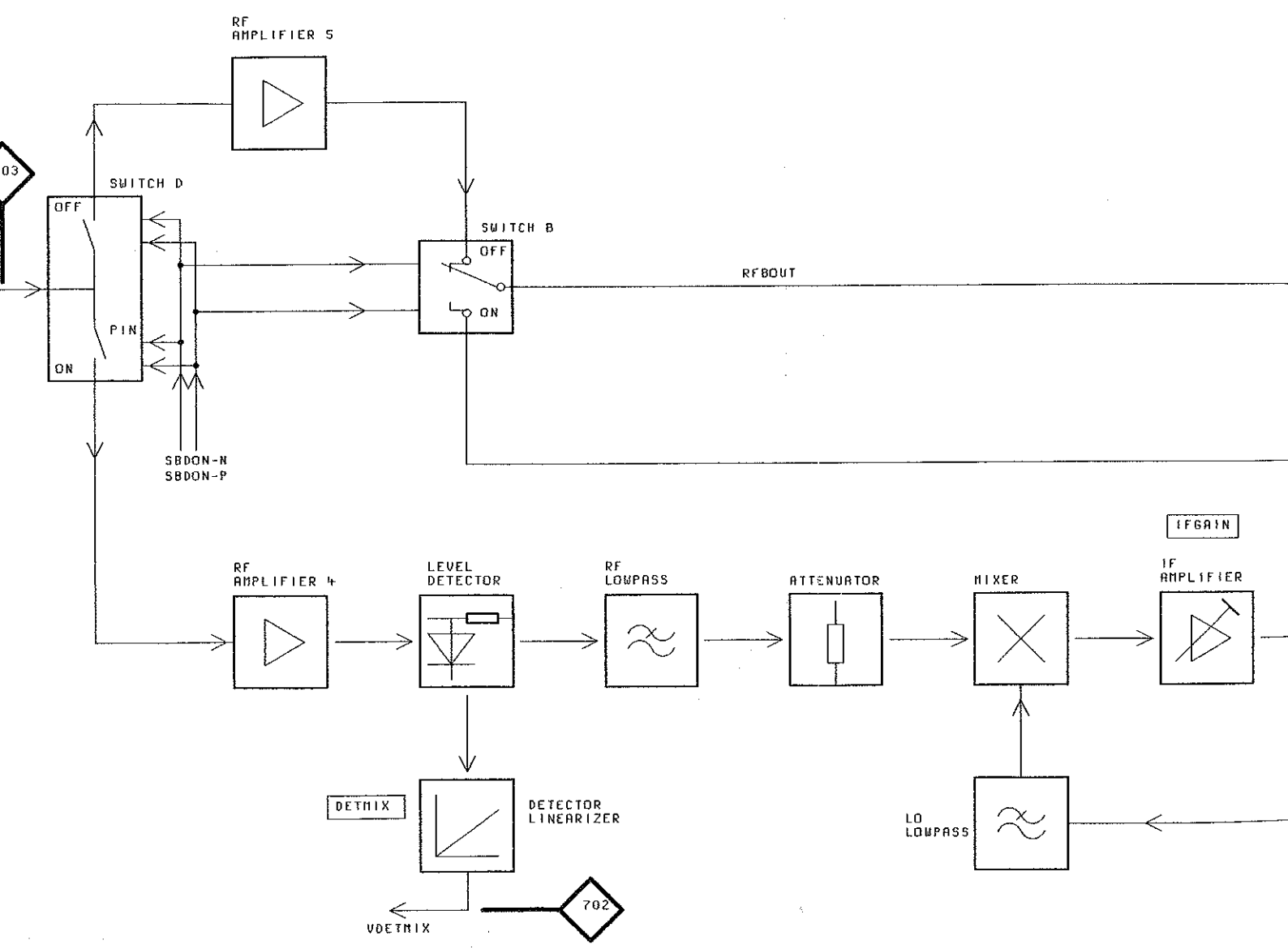

VARIANTEN,
UND
SIEHE SA.
ON MODELS,
VALUES AND
PARTS LIST.



ACHTUNG: EGB!
ELEKTROSTATISCH GEFÄHRDETE
BAUELEMENTE ERFORDERN EINE
BESONDERE HANDHABUNG.
ATTENTION ESD!
ELECTROSTATIC SENSITIVE DEVICES
REQUIRE A SPECIAL HANDLING

04/01		10.03.97	EI	MENP	TAG
				BEARB.	
				GEPR.	
				NORM	
				PLOTT	10.03.97
04/		11.07.96	DR		
REND. IND.	ÄNDERUNGS- MITTEILUNG	DATUM	NAME	 ZU GERÄT... SMY	

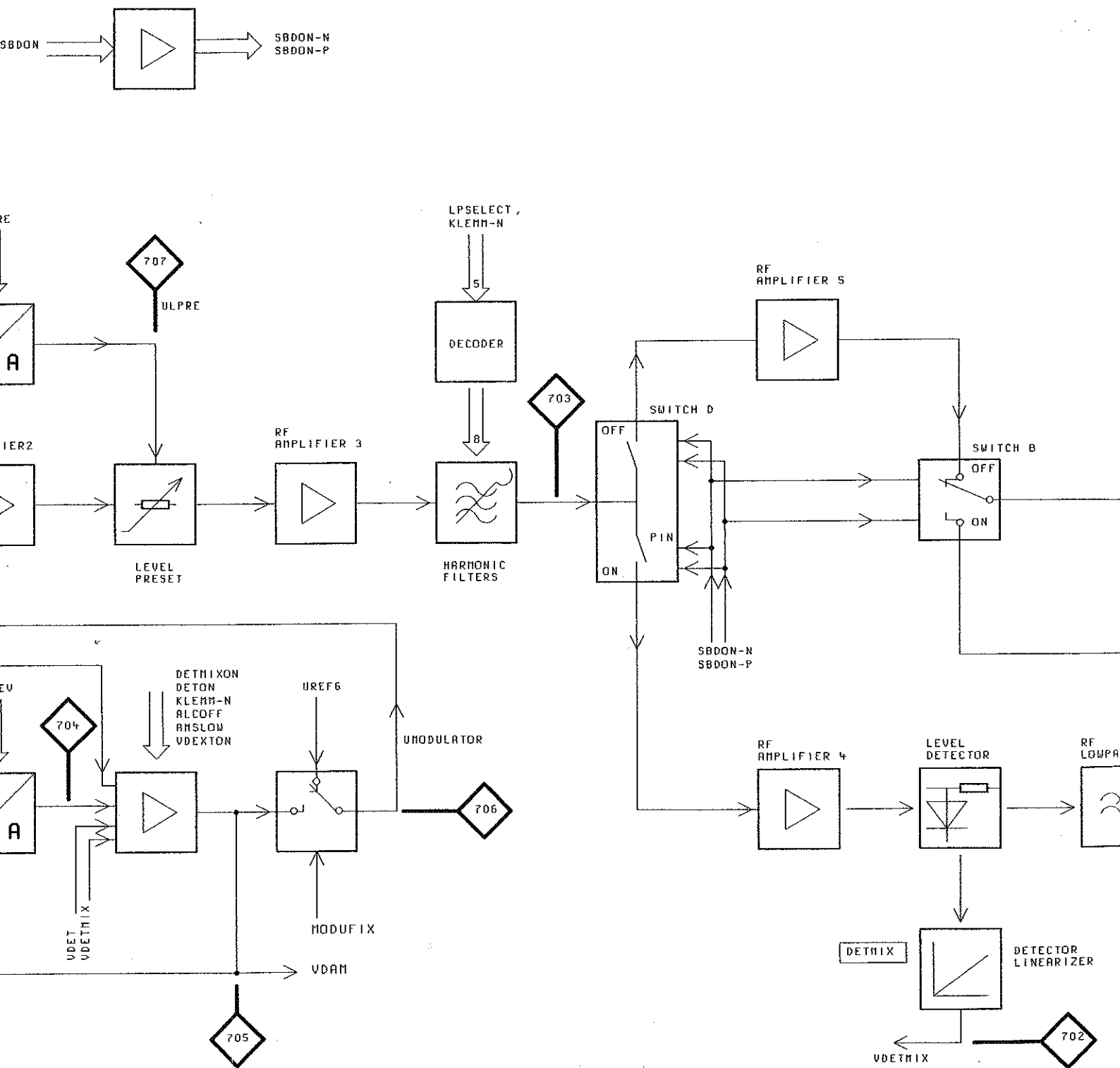

BINDENDE ANGABEN UEBER VARIANTEN,
TRIMMWERTE, BAUTEILWERTE UND
NICHT BESTUECKTE BAUTEILE SIEHE SA.
FOR BINDING INFORMATION ON MODELS,
TRIMMING AND COMPONENTS VALUES AND
NONFITTED COMPONENTS SEE PARTS LIST.

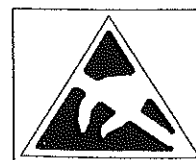

ACHTUNG: EGB!
ELEKTROSTATISCH GEFÄHRDETE
BAUELEMENTE ERFORDERN EINE
BESONDERE HANDHABUNG.
ATTENTION ESD!
ELECTROSTATIC SENSITIVE DEVICES
REQUIRE A SPECIAL HANDLING

- LPRE
- RFLEV
- AMSLOW
- ALCOFF
- RFLEVENABLE
- DETON
- VDEXTON
- DETHIXON
- MODUFIX
- SACON
- AM
- BP30N
- BP20N
- BP10N
- SB00N
- LPSELECT
- BLANKENABLE
- BLANKINVERS
- HFINTENABLE
- AMINVERS
- DIAGON
- DIAG

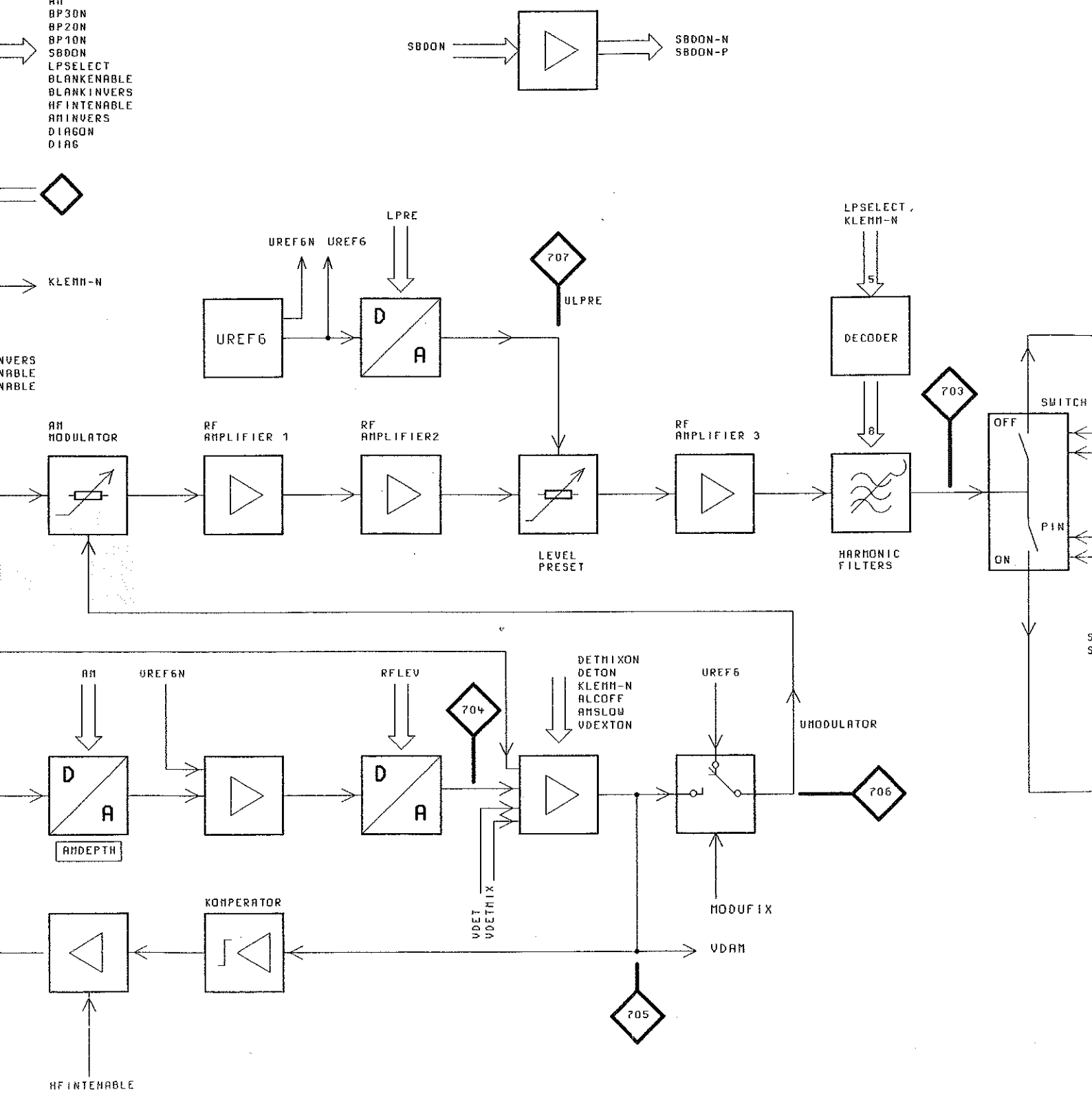

BINDENDE ANGABEN UEBER VARIANTEN,
 TRIMMWERTE, BAUTEILWERTE, UND
 NICHT BESTUECKTE BAUTEILE SIEHE SA.
 FOR BINDING INFORMATION ON MODELS,
 TRIMMING AND COMPONENTS VALUES AND
 NONFITTED COMPONENTS SEE PARTS LIST.

X2
11, 13, 16,
20, 21, 23,
27, 29, 31 — GND

24, 25 — VA15-P — +15V

28 — VDS-P — +5V

30 — VA15-N — -15V

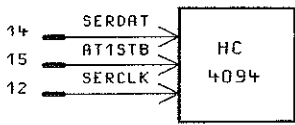

- LPRE
- RFLEV
- ANSLOW
- ALCOFF
- RFLEVENABLE
- DETON
- VDEXTON
- DETHIXON
- MODUFIX
- SACON
- AM
- BP30N
- BP20N
- BP10N
- SBDON
- LPSELECT
- BLANKENABLE
- BLANKINVERS
- HFINTENABLE
- AMINVERS
- DIAGON
- DIAG

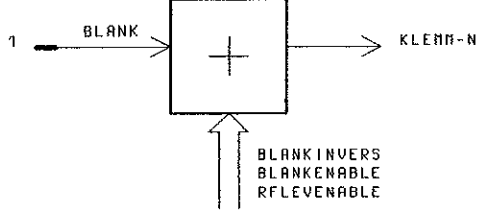

X224
FSYN
65...1040MHZ
6...12DBM

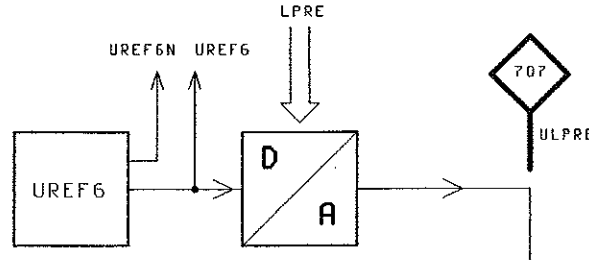
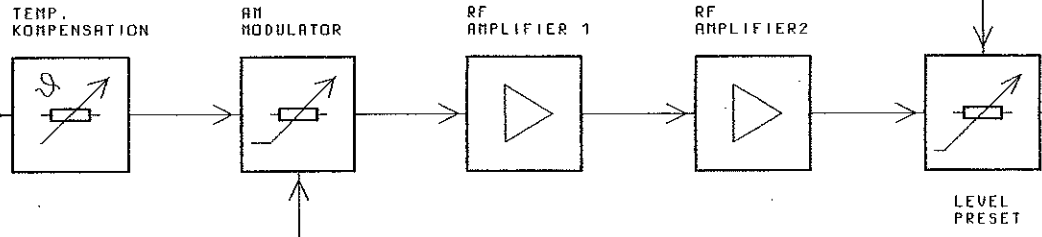

5 — DETEXT

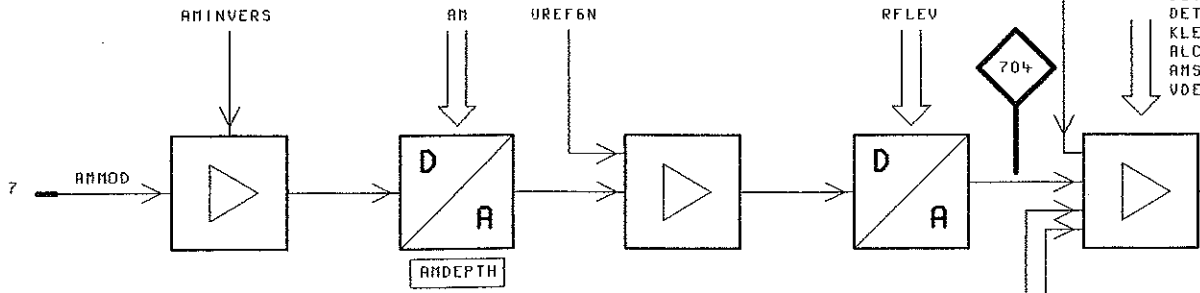

17 — HF INT

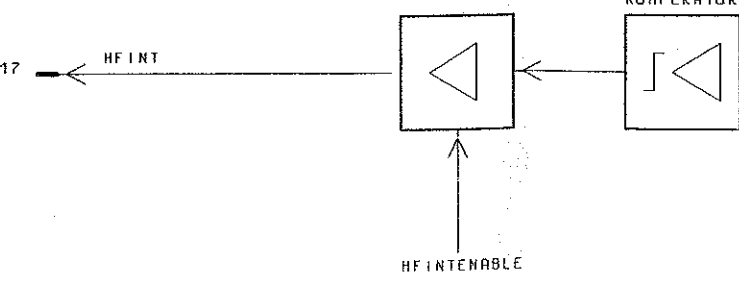

FÜR DIESE UNTERLAGE
BEHALTEN WIR UNS ALLE RECHTE VOR

ZEICHN.-NR.

(SHEET 3)

8*20K B

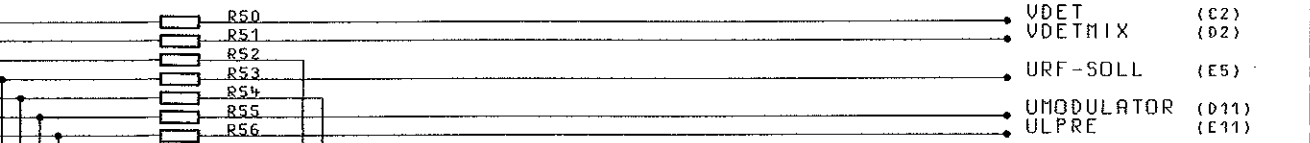

8 X 10K B

8 X 10K B

HF-INT-ENABLE
TO SHEET 10

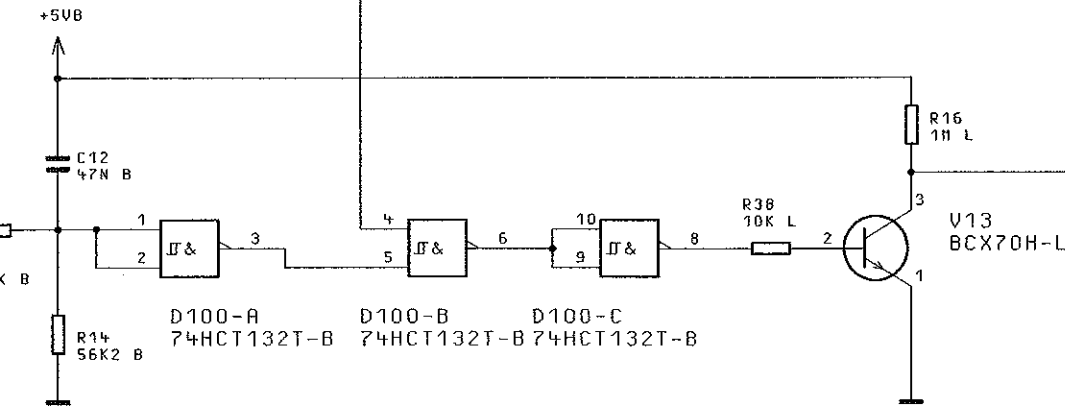

STUECKT

BINDENDE ANGABEN UEBER VARIANTEN,
TRIMMWERTE, BAUTEILWERTE UND
NICHT BESTUECKTE BAUTEILE SIEHE SA.

FOR BINDING INFORMATION ON MODELS,
TRIMMING AND COMPONENTS VALUES AND
NONFITTED COMPONENTS SEE PARTS LIST.

04/01		10.03.97	EI	MENP	TAG	NAME	BENENNUNG		
				BEARB.		EI	AUSGANGSTEIL 1.046GHZ OUTPUT UNIT 1.046GHZ		
				GEPR.					
				NORM					
				PLOTT	10.03.97				
04/		11.07.96	DR				ZEICHN.-NR.	BLATT-NR.	
REND. IND.	ÄNDERUNGS- MITTEILUNG	DATUM	NAME				1062.6209.01S	2+	
				ZU GERÄT	SMY	REG.-F.V.	1062.5502	ERSTE Z.	1062.5502

9

10

11

12

DIAGNOSE

(SHEET 2/E3)

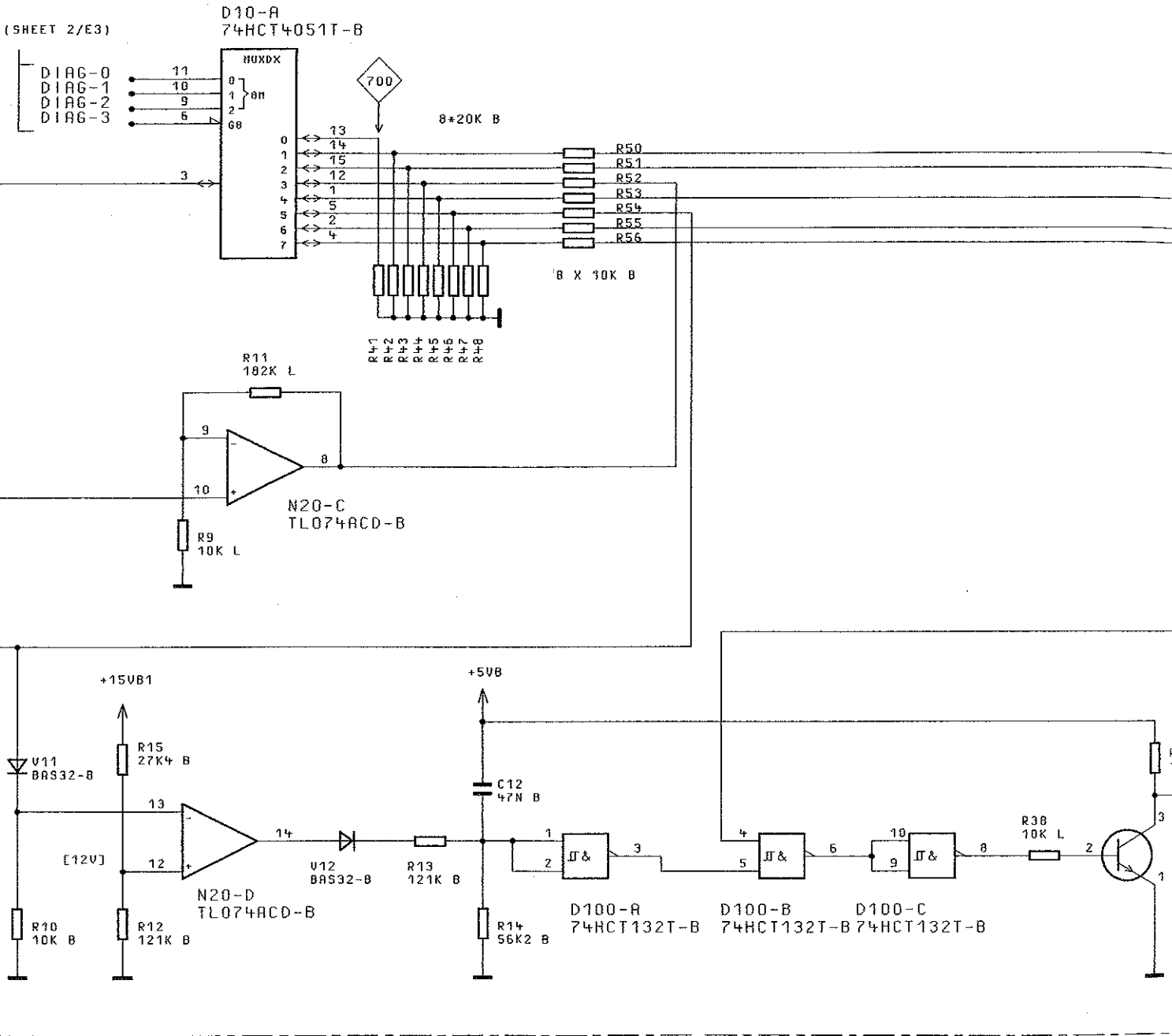

N.F. - NOT FITTED / NICHT BESTUECKT

BINDENDE ANGABEN UEBER VARIANTEN,
TRIMMWERTE, BAUTEILWERTE UND
NICHT BESTUECKTE BAUTEILE SIEHE SA.

FOR BINDING INFORMATION ON
TRIMMING AND COMPONENTS VA
NONFITTED COMPONENTS SEE P

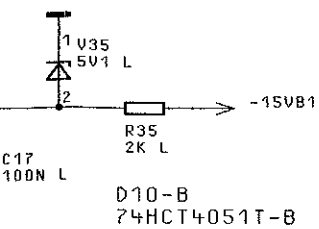

04/01		10.03.97	E I	MENP	TAG	NARE	BENEN
				BEARB.		E I	
				GEPR.			
				NORM			
				PLOTT	10.03.97		
04/		11.07.96	DR				ZEICH
ÄND. IND.	ÄNDERUNGS- MITTEILUNG	DATUM	NAME				ZU GERÄT

ACHTUNG: EGB!
 ELEKTROSTATISCH GEFÄHRDETE
 BAUELEMENTE ERFORDERN EINE
 BESONDERE HANDHABUNG.
ATTENTION ESD!
 ELECTROSTATIC SENSITIVE DEVICES
 REQUIRE A SPECIAL HANDLING

DIAGNOSE

(SHEET 2/E3)

D10-A
74HCT4051T-B

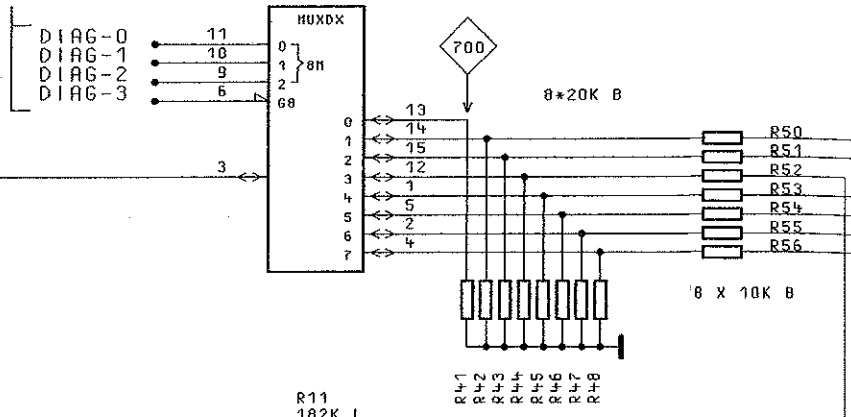

DET FILT

UREGELVERST

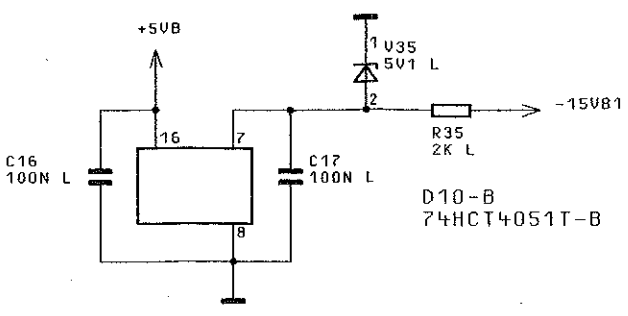
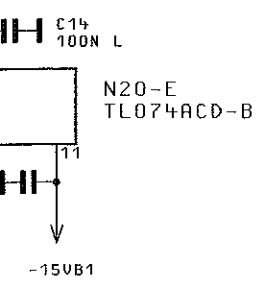
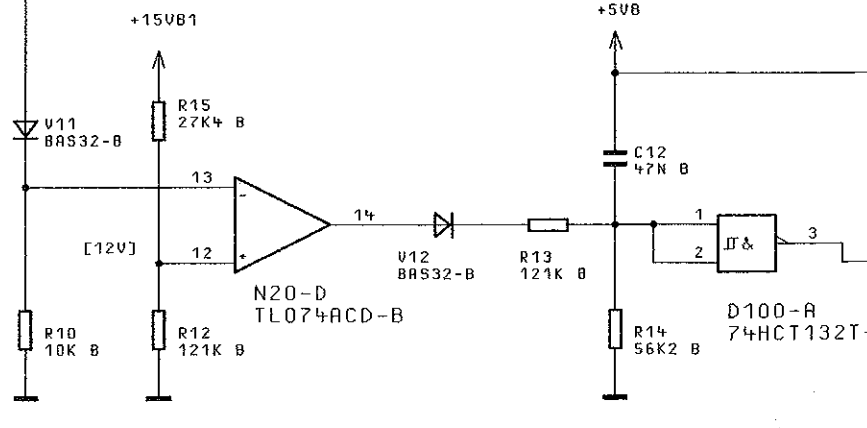
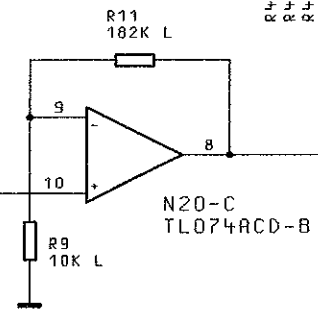

N.F. - NOT FITTED / NICHT BESTUECKT

BINDENDE ANGABEN
TRIMMWERTE, BAUTEILE
NICHT BESTUECKTE

04/01	
04/	
REND.	RENDERUN
IND.	MITTELL

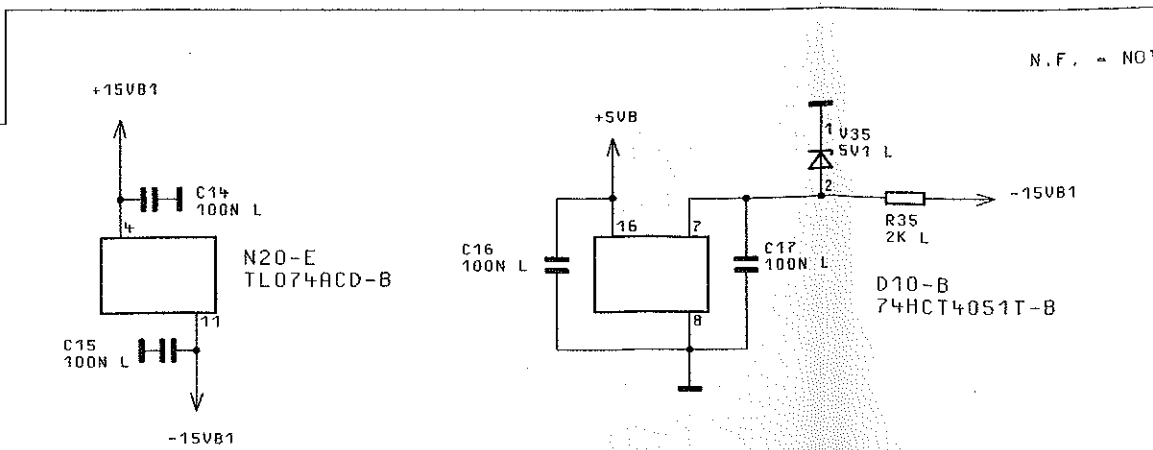
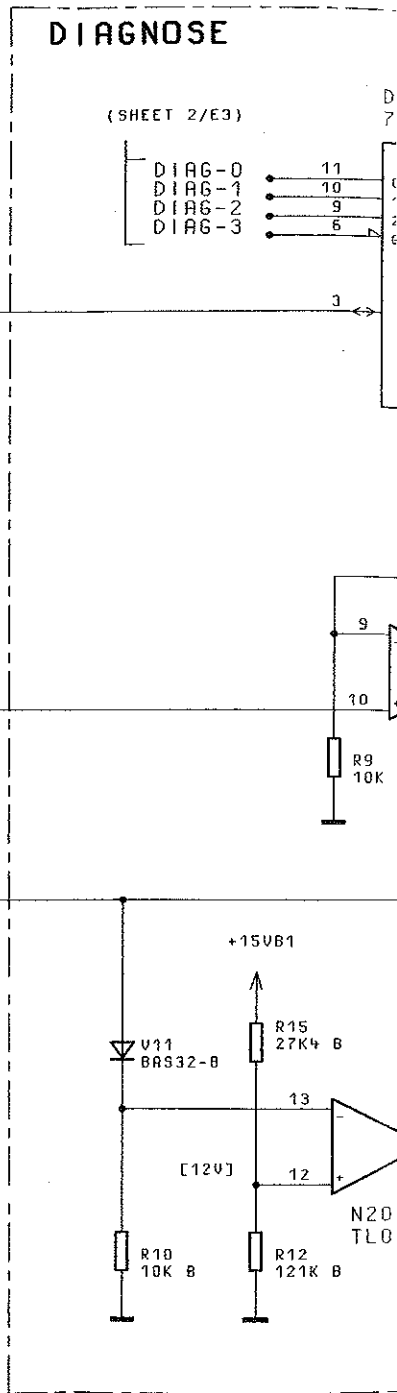
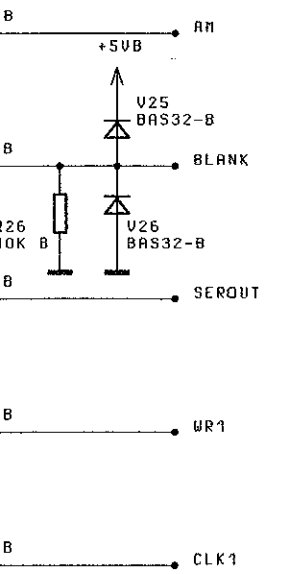
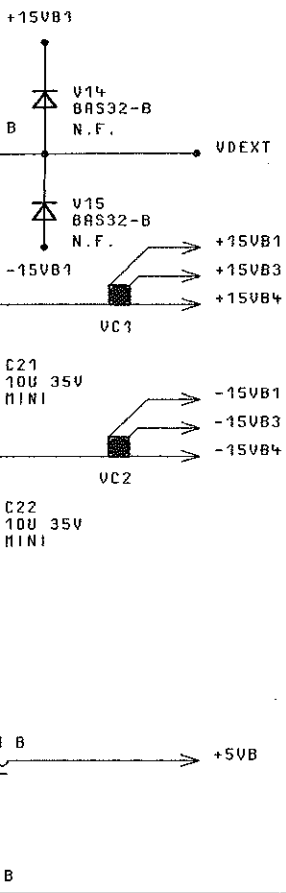

ACHTUNG: EGB!
 ELEKTROSTATISCH GEFÄHRDETE
 BAUELEMENTE ERFORDERN EINE
 BESONDERE HANDHABUNG.
ATTENTION ESD!
 ELECTROSTATIC SENSITIVE DEVICES
 REQUIRE A SPECIAL HANDLING

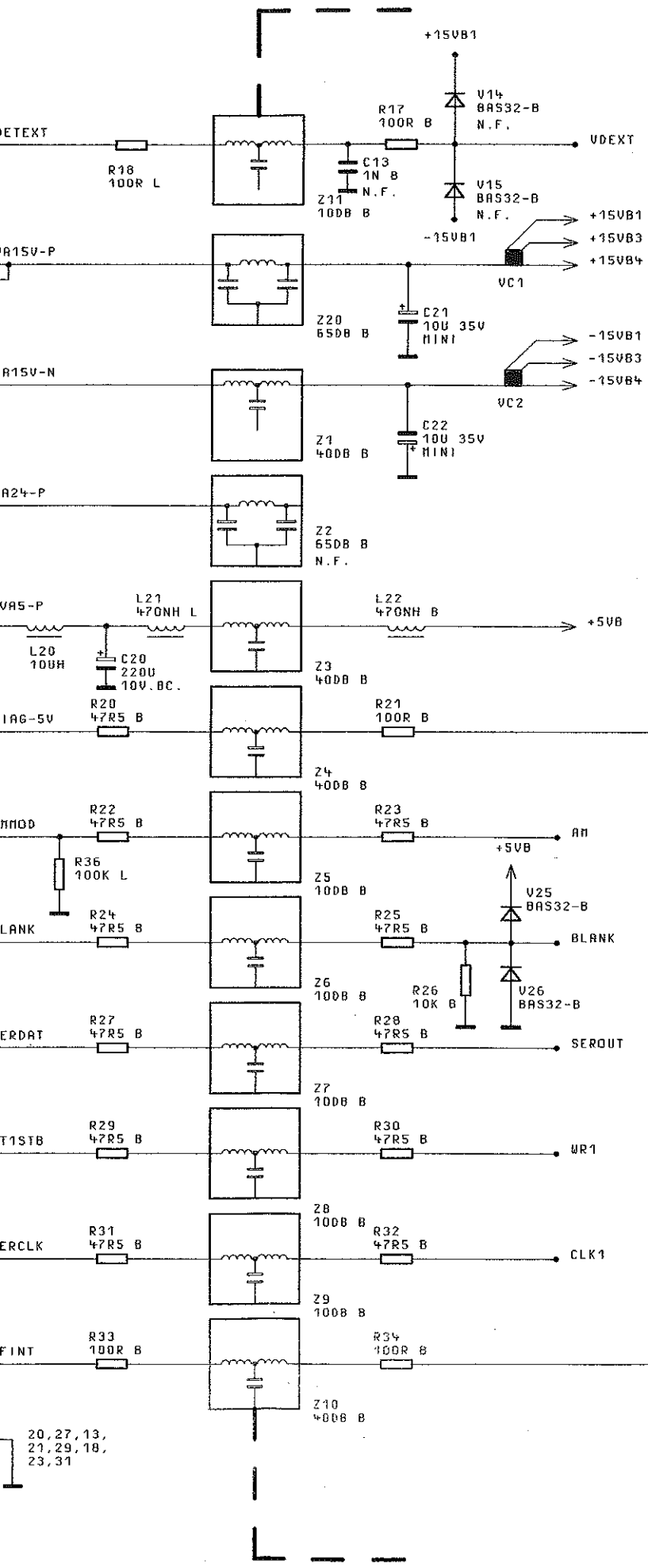

ACHTUNG: EGB!
 ELEKTROSTATISCH GEFÄHRDETE
 BAUELEMENTE ERFORDERN EINE
 BESONDERE HANDHABUNG.
ATTENTION ESD!
 ELECTROSTATIC SENSITIVE DEVICES
 REQUIRE A SPECIAL HANDLING

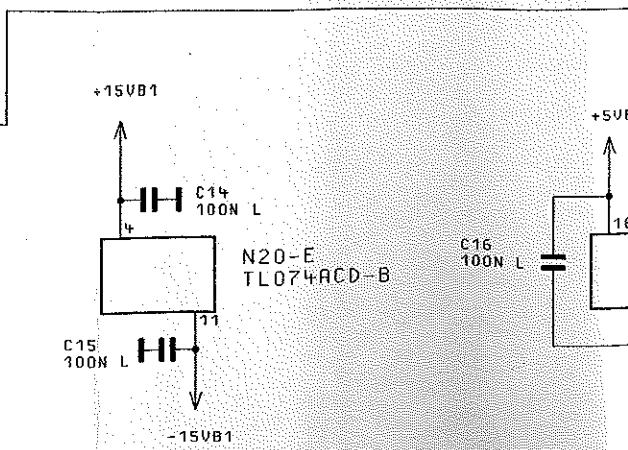

20, 27, 13,
 21, 29, 18,
 23, 31



FÜR DIESE UNTERLAGE
BEHALTEN WIR UNS ALLE RECHTE VOR

ICHN - NR

F
E
D
C
B
A

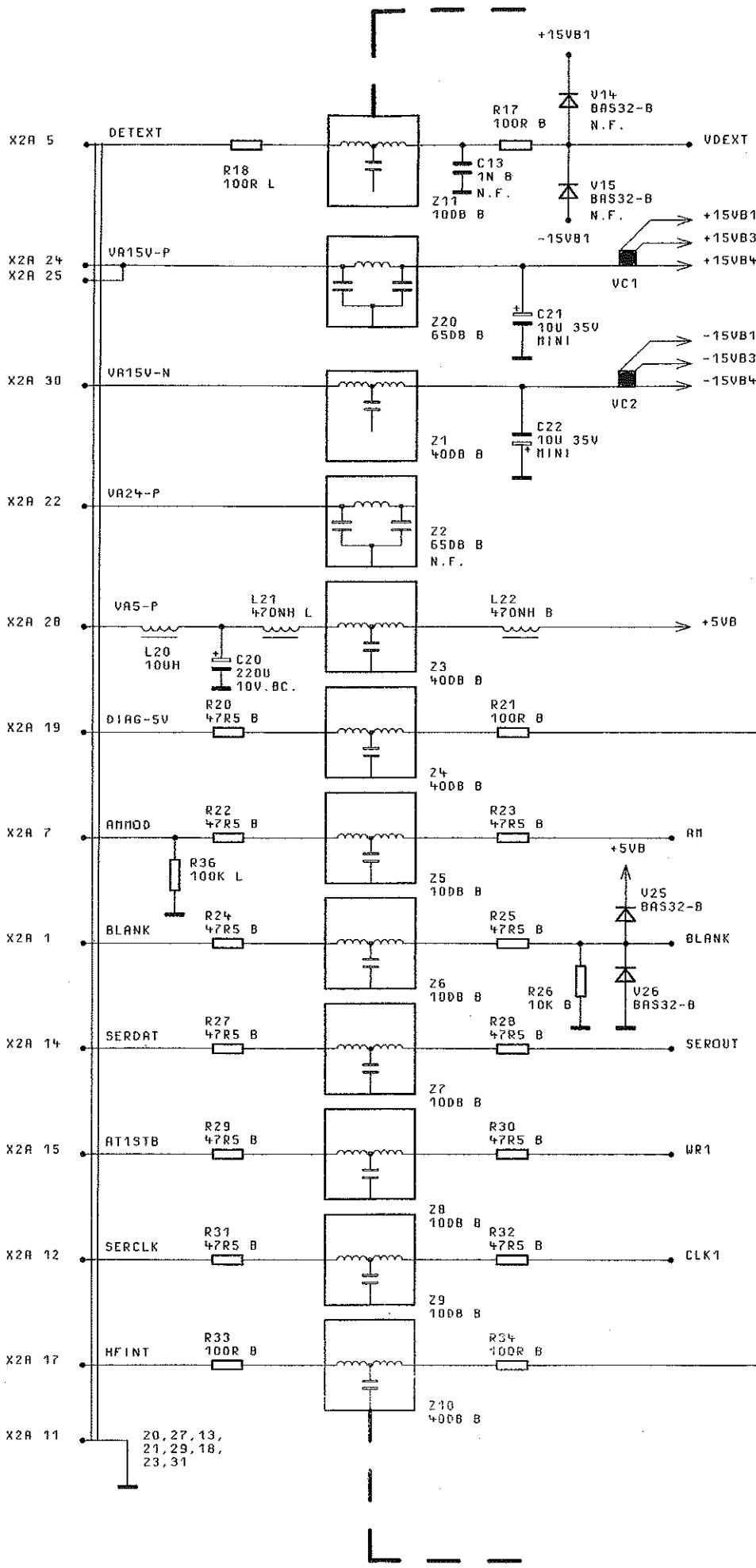

C15
100N L

1 2 3 4

P306
P305

P352

P353

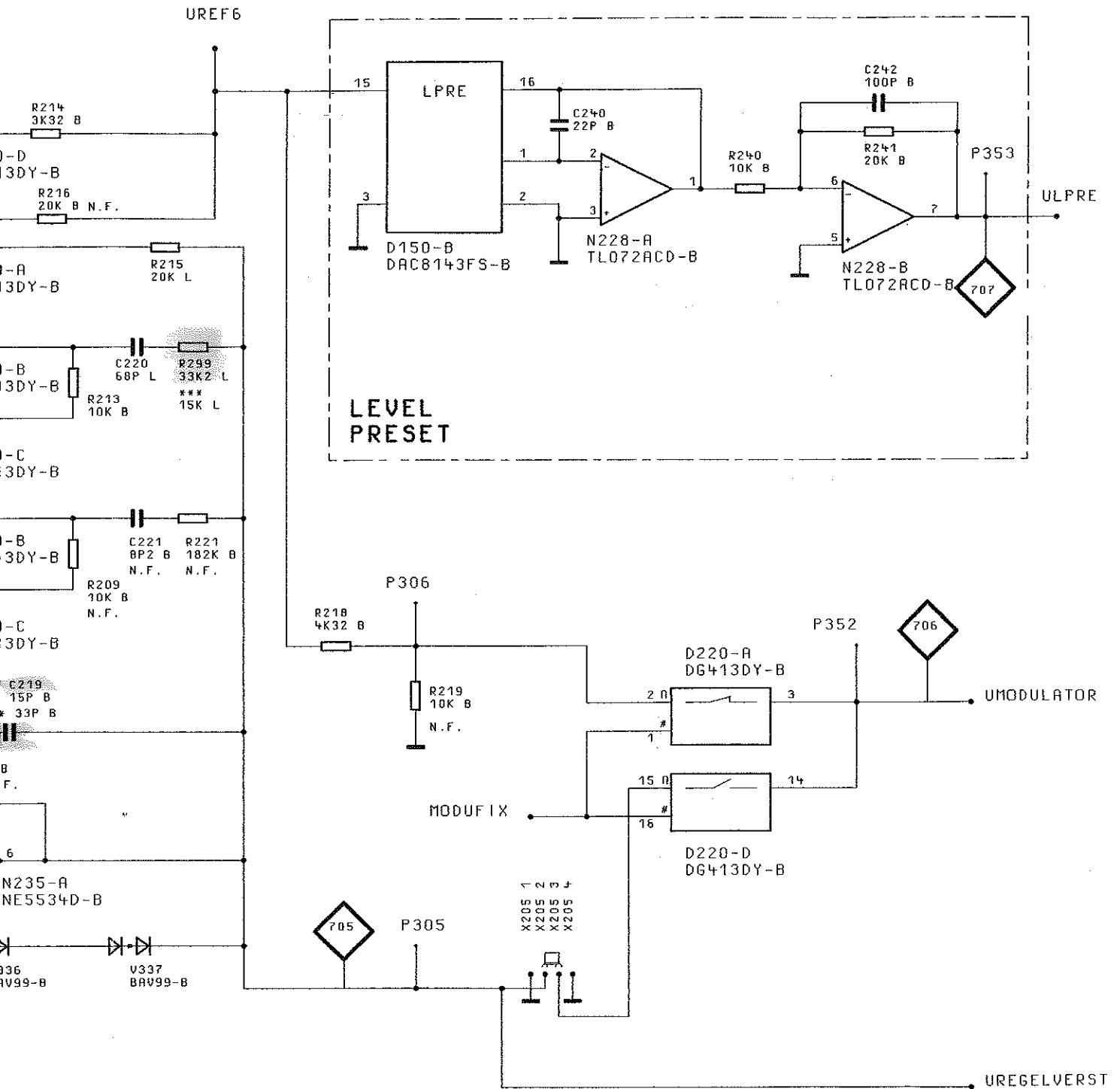

N.F. - NOT FITTED / NICHT BESTUECKT
 ** - VAR. 04 / MOD. 04
 *** - VAR. 06 / MOD. 06
 (MIT/WITH OPTION SMY-B40)

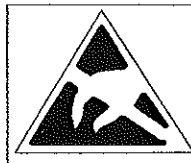

ACHTUNG: EGB!
 ELEKTROSTATISCH GEFÄHRDETE
 BAUELEMENTE ERFORDERN EINE
 BESONDERE HANDhabUNG.
 ATTENTION ESD!
 ELECTROSTATIC SENSITIVE DEVICES
 REQUIRE A SPECIAL HANDLING

04/01	10.03.97	EI	MENP	TAG	NAME	BENENNUNG
			BEARB.		EI	AUSGANGSTEIL 1.046GHZ OUTPUT UNIT 1.046GHZ
			GEPR.			
			NORM			
			PLOTT	10.03.97		
04/	11.07.96	DR				ZEICHN.-NR.
REND. IND.	RENDERUNGS- MITTEILUNG	DATUM	NAME	ZU GERÄT	SMY	1062.6209.015
				REG. I. V.	1062.5502	ERSTE Z.
						1062.5502

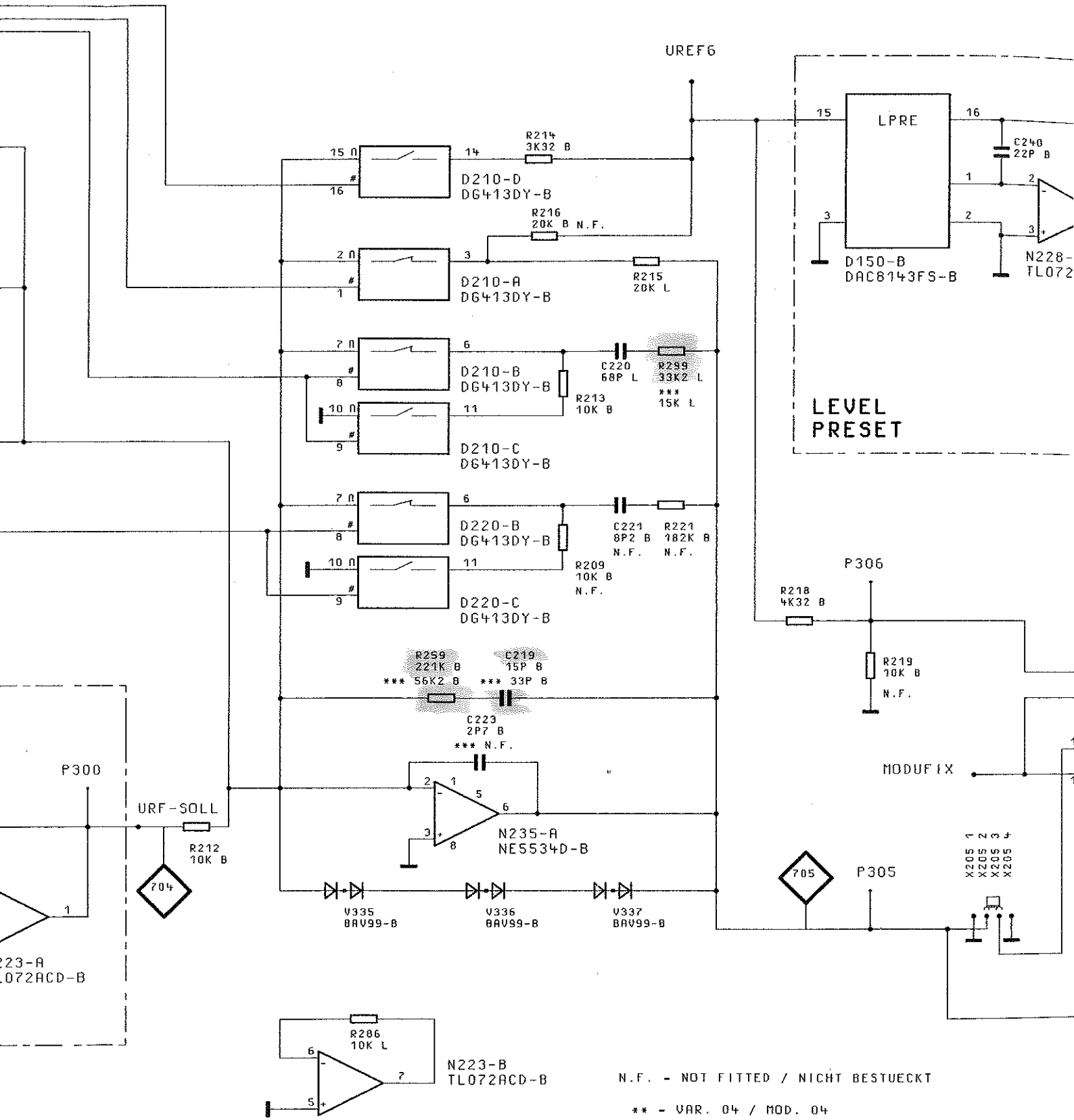

N.F. - NOT FITTED / NICHT BESTUECKT
 ** - VAR. 04 / MOD. 04
 *** - VAR. 06 / MOD. 06
 (MIT/WITH OPTION SMY-B40)

BINDENDE ANGABEN UEBER VARIANTEN,
 TRIMMWERTE, BAUTEILWERTE UND
 NICHT BESTUECKTE BAUTEILE SIEHE SA.
 FOR BINDING INFORMATION ON MODELS,
 TRIMMING AND COMPONENTS VALUES AND
 NONFITTED COMPONENTS SEE PARTS LIST.

04/01	10.03.97	E I	MENP	TAG	NAME
			BEARB.		E I
			GEPR.		
			NORM		
			PLOTT	10.03.97	
04/	11.07.96	DR			
REN. IND.	ÄNDERUNGS- MITTEILUNG	DATUM	NAME	 ROHDE & SCHWARZ ZU GERÄT SMY	

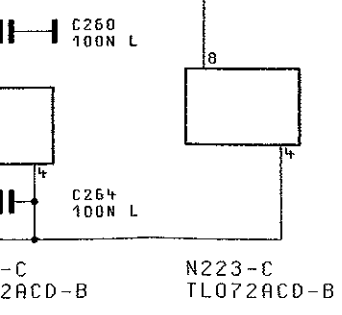

P385

P285

P300

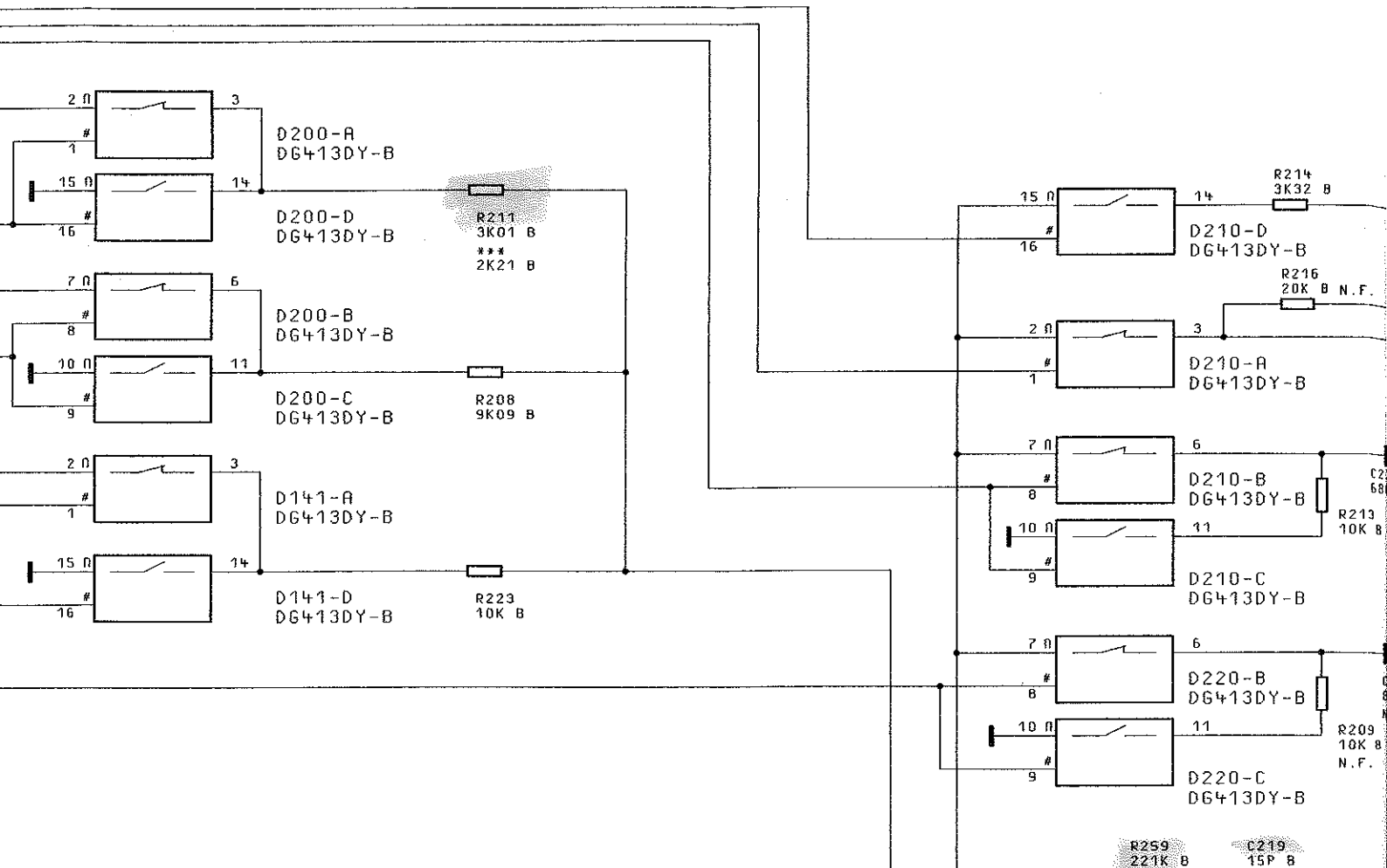

RF LEVEL

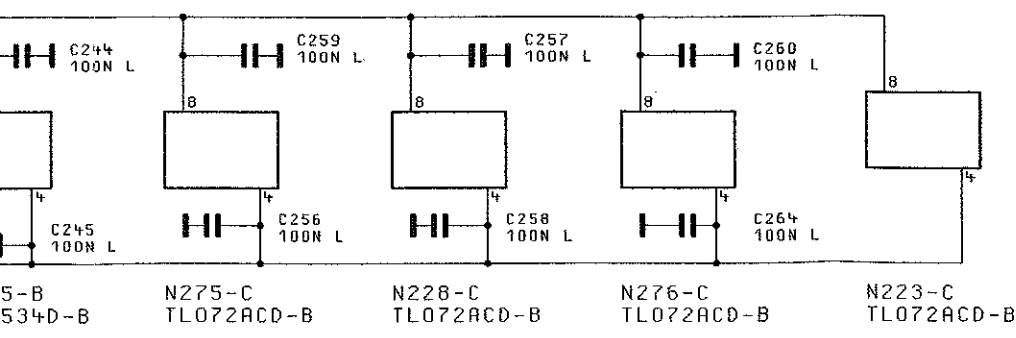
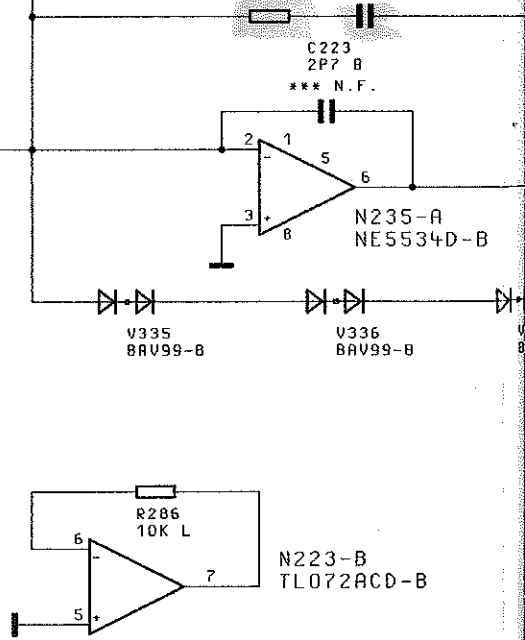
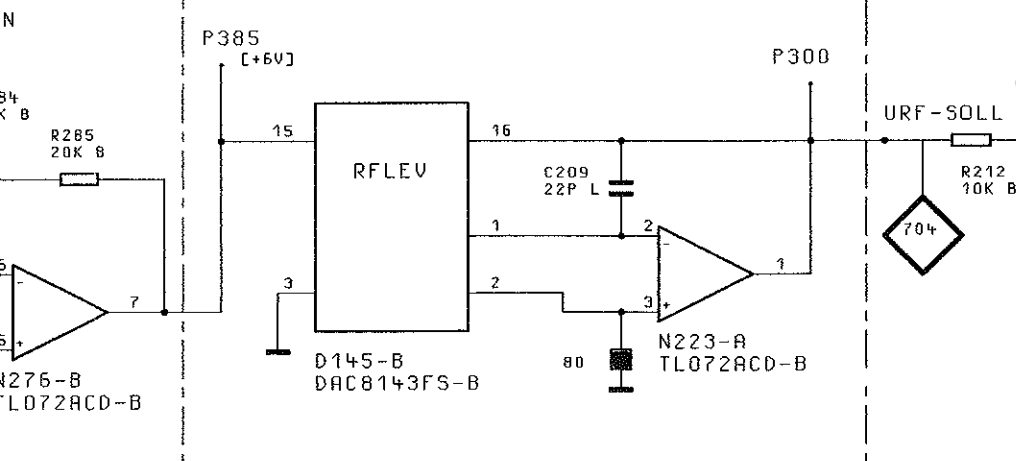

BINDENDE ANGABEN UEBER VARIANTEN,
TRIMMWERTE, BAUTEILWERTE UND
NICHT BESTUECKTE BAUTEILE SIEHE SA.

FOR BINDING INFORMATION ON MODELS,
TRIMMING AND COMPONENTS VALUES AND
NONFITTED COMPONENTS SEE PARTS LIST.

04/04
04/
RE 19
IND

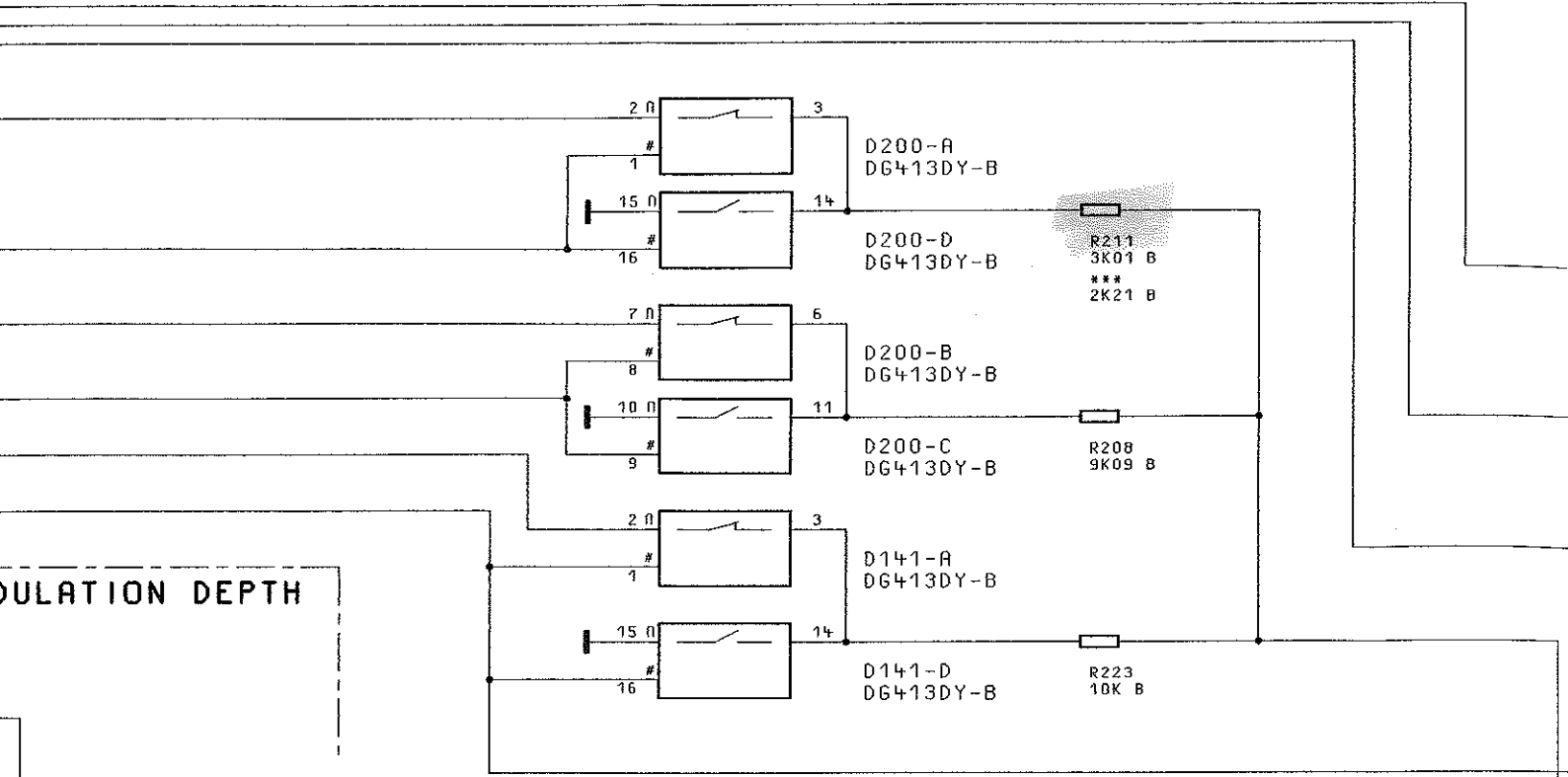

MODULATION DEPTH

AMDEPTH
R280
RTR 5K B

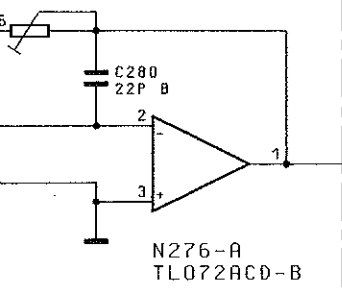

RF LEVEL

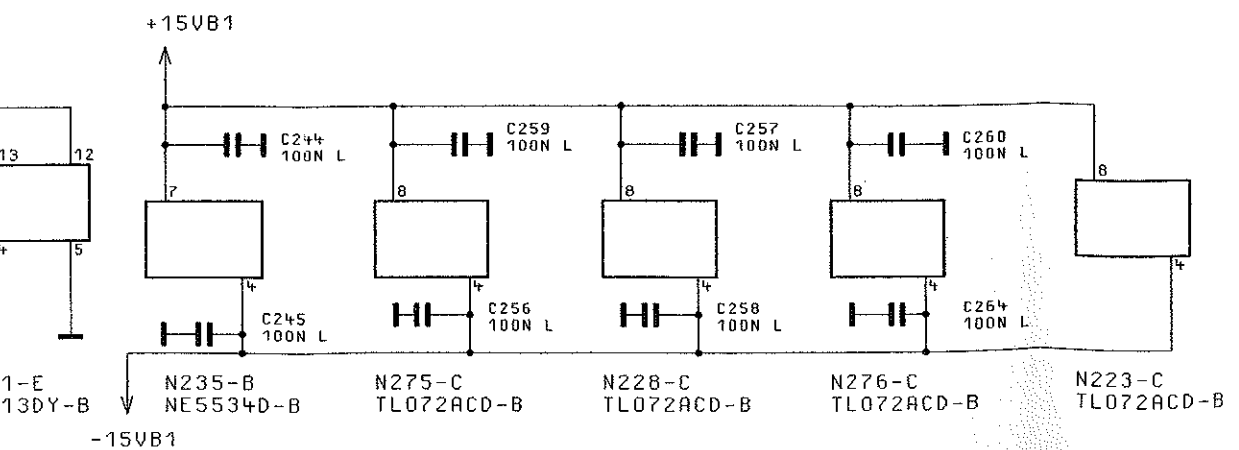
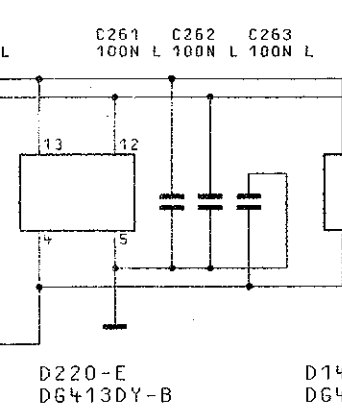
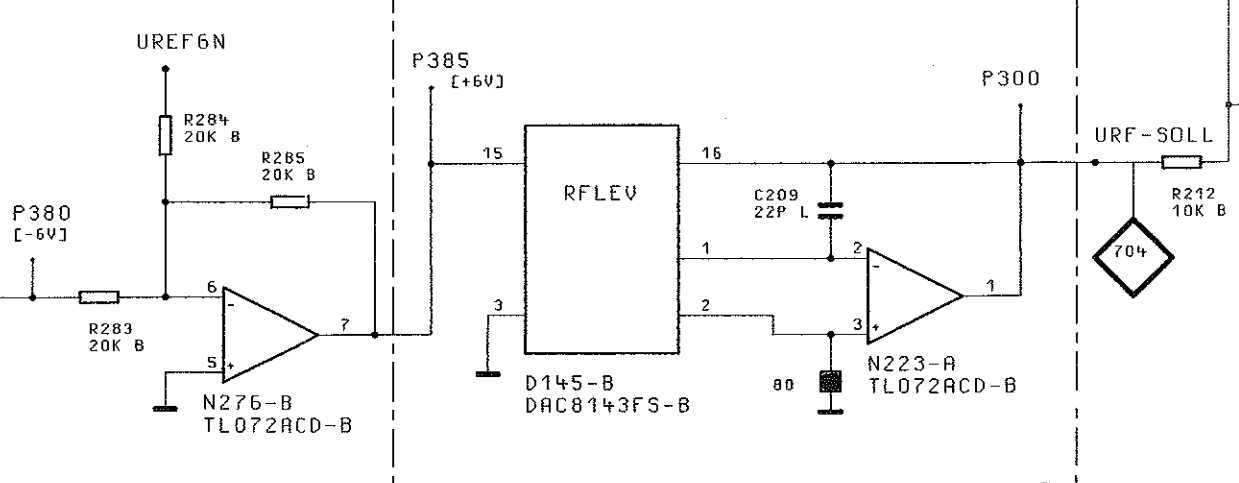

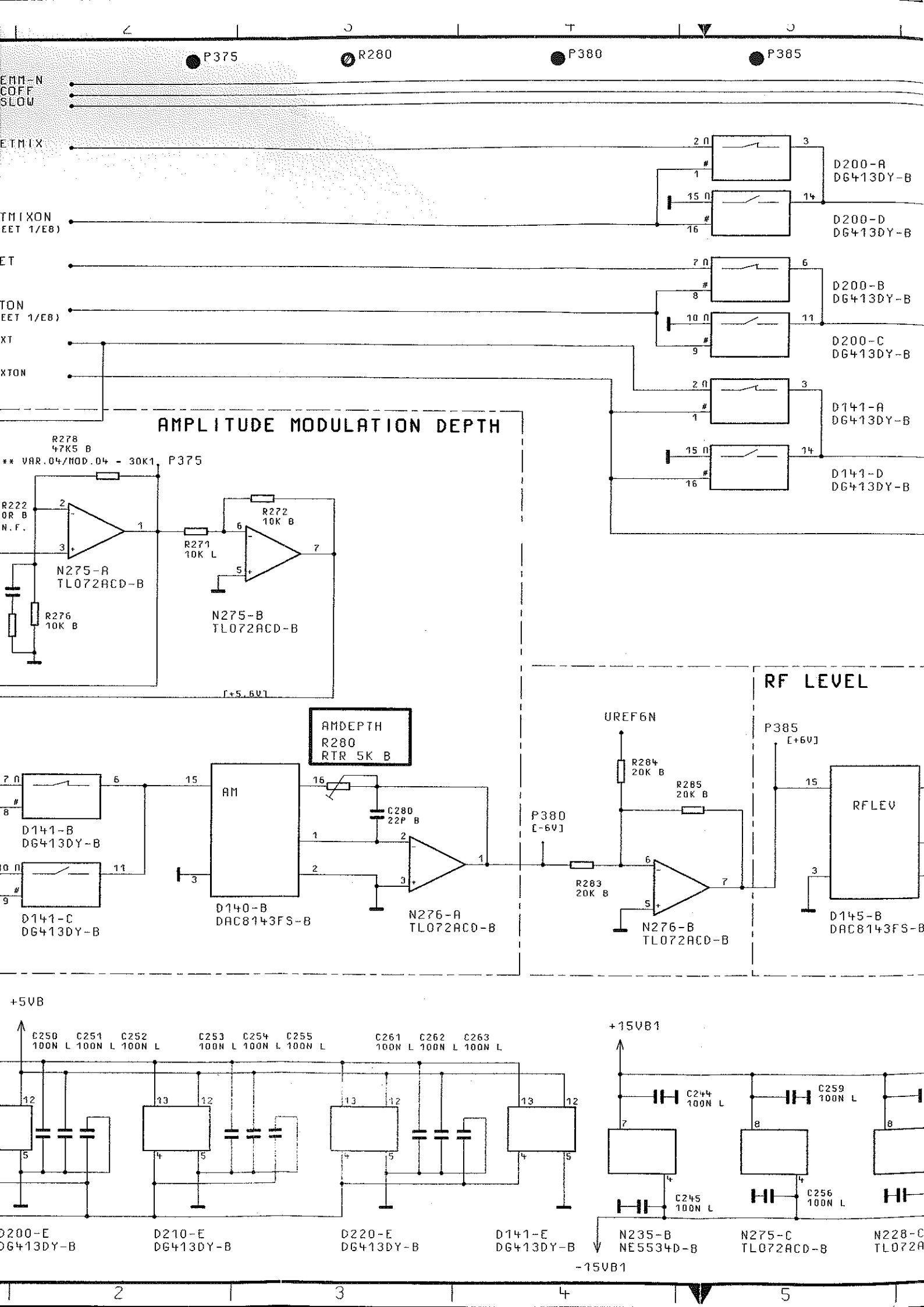

AMPLITUDE MODULATION DEPTH

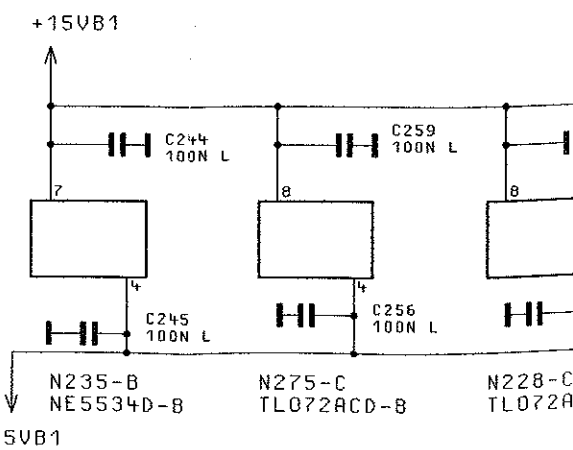
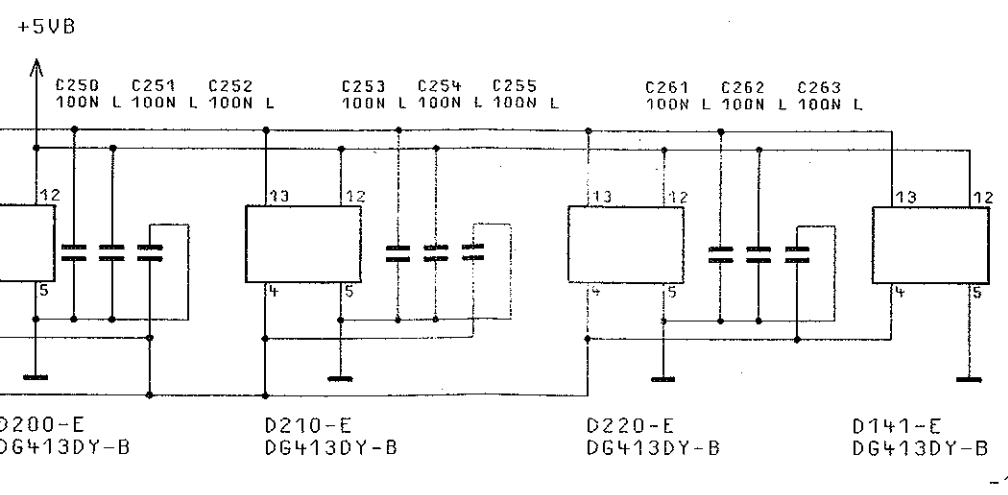
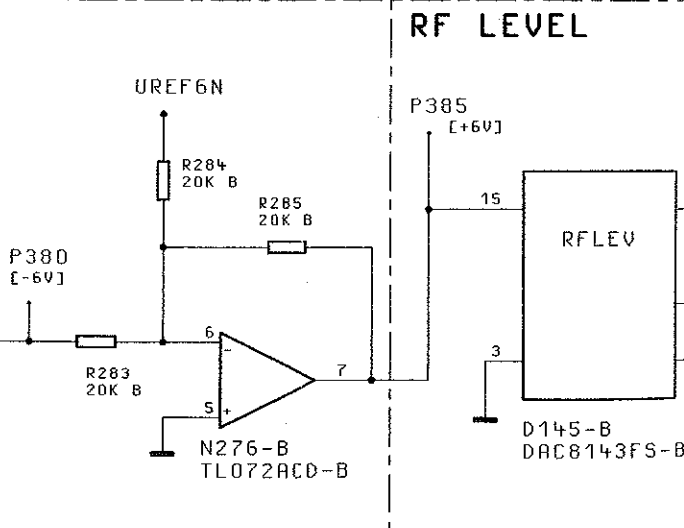
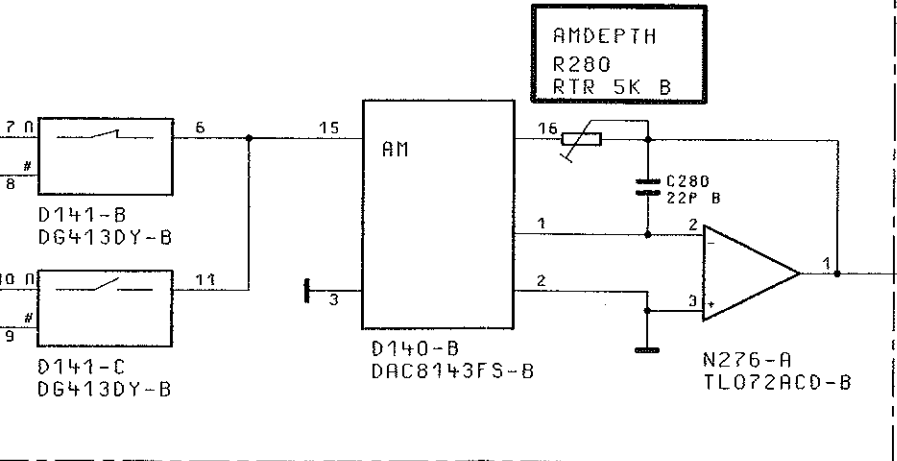
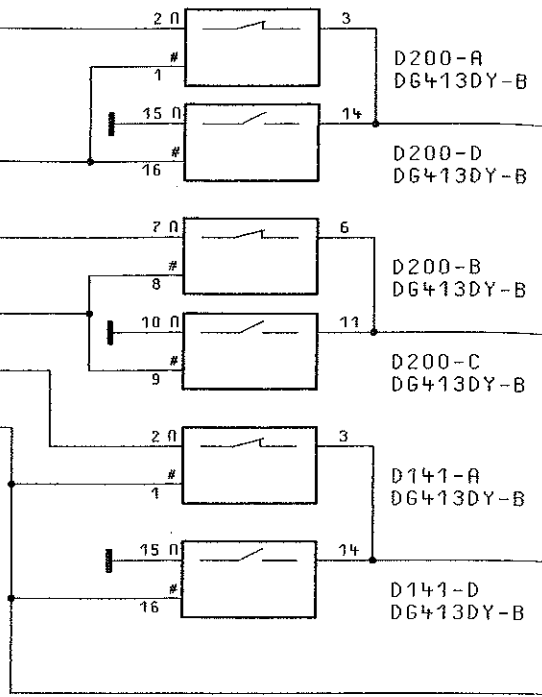
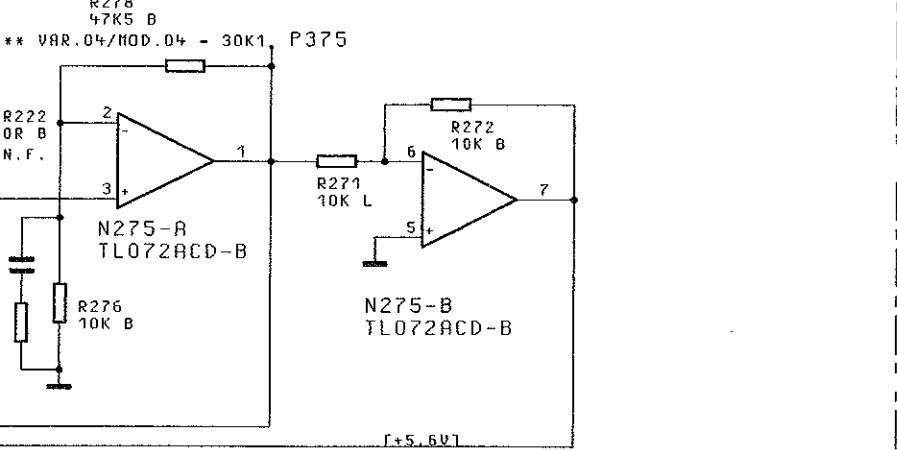

FÜR DIESE UNTERLAGE
BEHALTEN WIR UNS ALLE RECHTE VOR

KLEMM-N
ALCOFF
AMSLow

P375

R280

P380

VDETMIX

DETMIXON
(SHEET 1/E8)

VDET

DETON
(SHEET 1/E8)

VDEXT

VDEXTON

AMPLITUDE MODULATION DEPTH

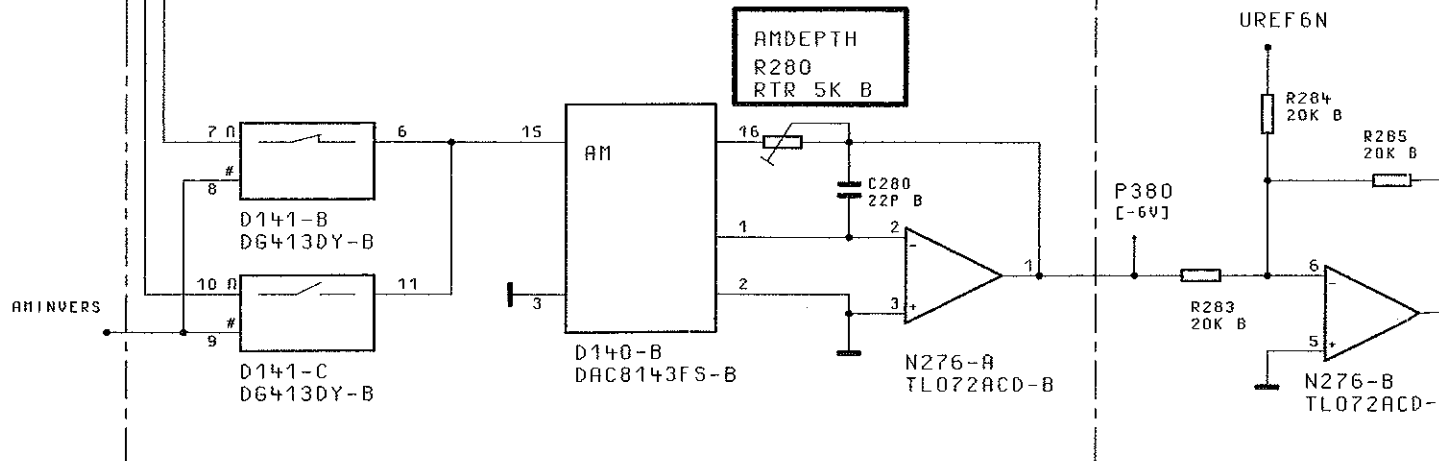
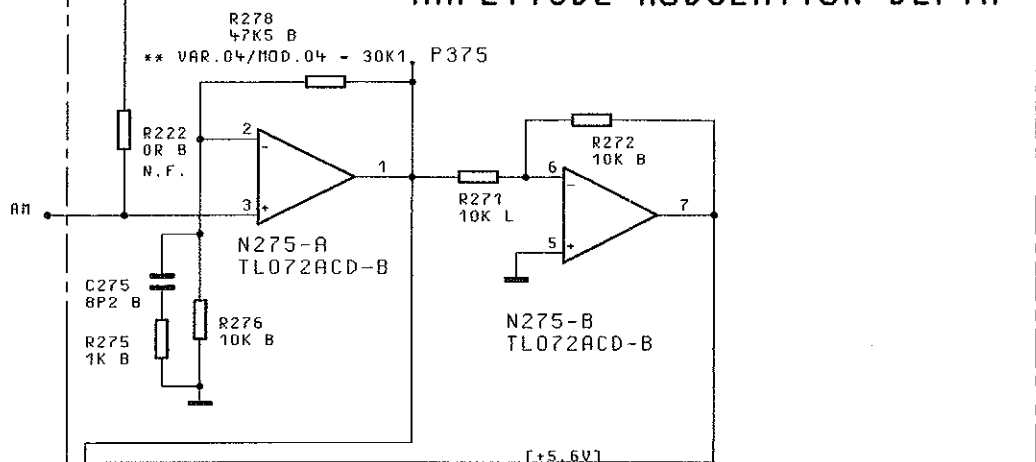

+15VB1 +5VB

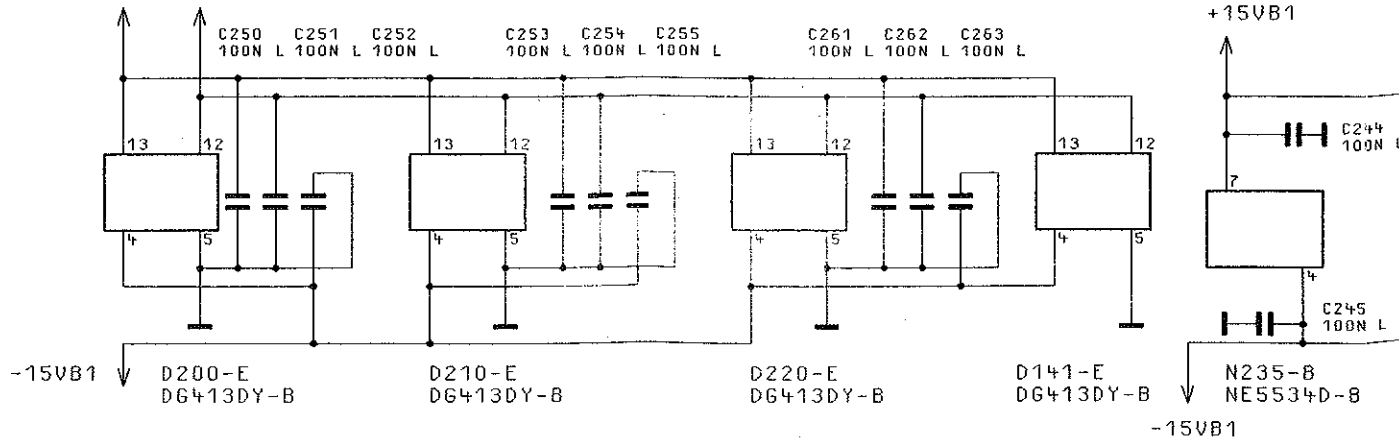

TECHN.-NR

1 2 3 4

RF AMPLIFIER 1

RF AMPLIFIER 2

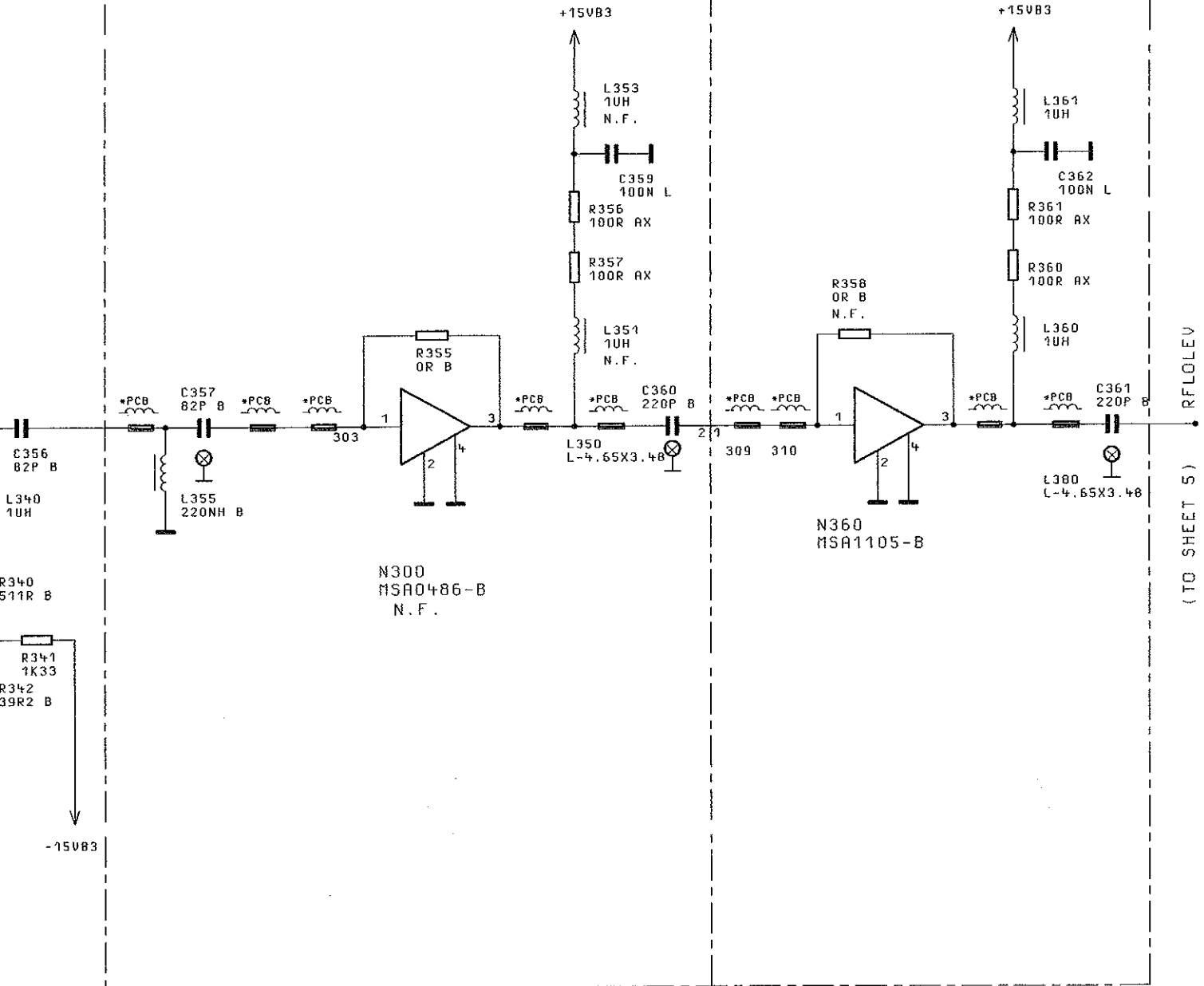

BINDENDE ANGABEN UEBER VARIANTEN,
TRIMMWERTE, BAUTEILWERTE UND
NICHT BESTUECKTE BAUTEILE SIEHE SA.

FOR BINDING INFORMATION ON MODELS,
TRIMMING AND COMPONENTS VALUES AND
NONFITTED COMPONENTS SEE PARTS LIST.

04/01		10.03.97	E1	MENP	TAG	NAME	BENENNUNG		
				BEARB.		E1	AUSGANGSTEIL 1.046GHZ OUTPUT UNIT 1.046GHZ		
				GEPR.					
				NORM					
				PLOTT	10.03.97				
04/		11.07.96	DR	 ROHDE & SCHWARZ			ZEICHN.-NR.		
REND. IND.	RENDERUNGS- MITTEILUNG	DATUM	NAME				1062.6209.015		
				ZU GERÄT	SMY	REG. I. V.	1062.5502	ERSTE Z.	1062.5502

RF AMPLIFIER 1

RF

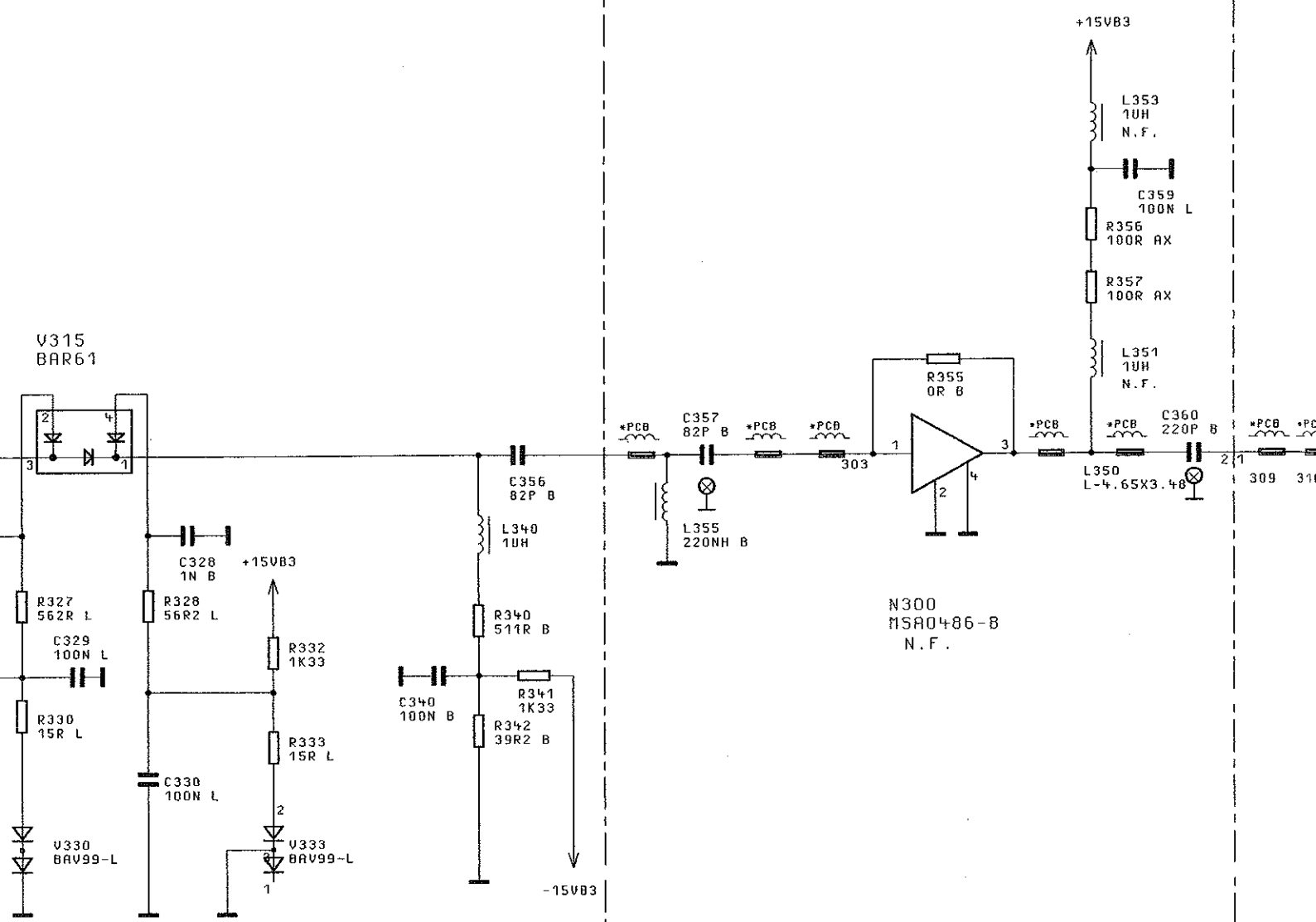

N.F. = NOT FITTED / NICHT BESTUECKT

BINDENDE ANGABEN UEBER VARIANTEN, TRIMMWERTE, BAUTEILWERTE UND NICHT BESTUECKTE BAUTEILE SIEHE SA.

FOR BINDING INFORMATION ON TRIMMING AND COMPONENTS VAL NONFITTED COMPONENTS SEE PA



ACHTUNG: EGB!
ELEKTROSTATISCH GEFAHRDETE BAUELEMENTE ERFORDERN EINE BESONDERE HANDHABUNG.
ATTENTION ESD!
ELECTROSTATIC SENSITIVE DEVICES REQUIRE A SPECIAL HANDLING

04/07		10.03.97	EI	MENP	TAB	NAME	BENENNUNG
				BEARB.		EI	AUSGABE
				GEPR.			
				NORM			
				PLOTT	10.03.97		
04/		11.07.96	DR	 ROHDE & SCHWARZ			ZEICHN.-NR.
REND. IND.	RENDERUNGS-MITTEILUNG	DATUM	NAME			REG. I. V.	
				ZU GERÄT SMY			

ATOR

RF AMPLIF

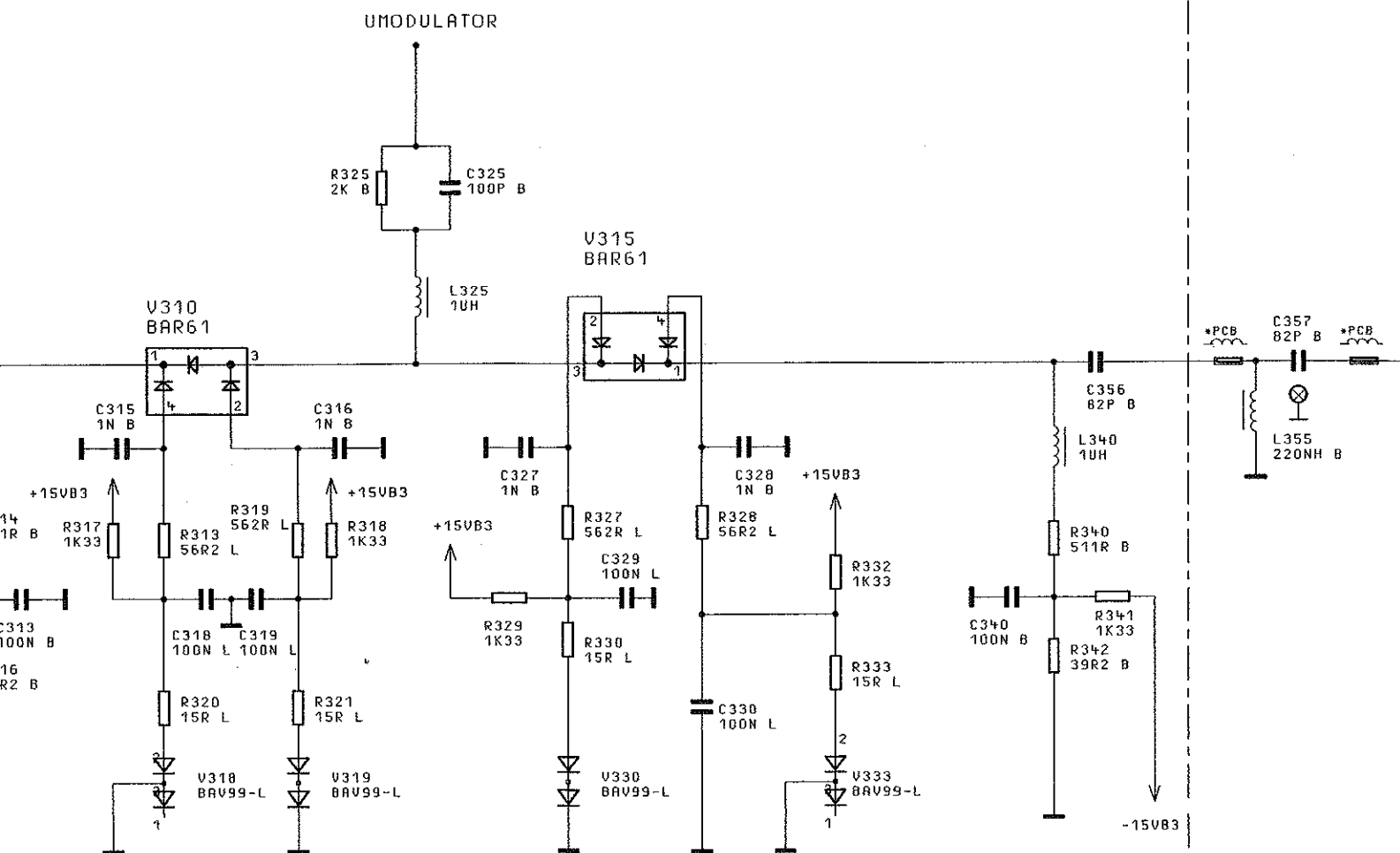

N.F. = NOT FITTED / NICHT BESTUECKT

BINDENDE ANGABEN UEBER TRIMMWERTE, BAUTEILNUMMERN UND NICHT BESTUECKTE BAUTEILE

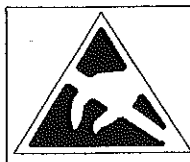

ACHTUNG: EGB!
 ELEKTROSTATISCH GEFAHRDETE
 BAUELEMENTE. ERFORDERN EINE
 BESONDERE HANDHABUNG.
ATTENTION ESD!
 ELECTROSTATIC SENSITIVE DEVICES
 REQUIRE A SPECIAL HANDLING

04/04	
04/	
REND. IND.	RENDERUNGS-MITTEILUNG

AM MODULATOR

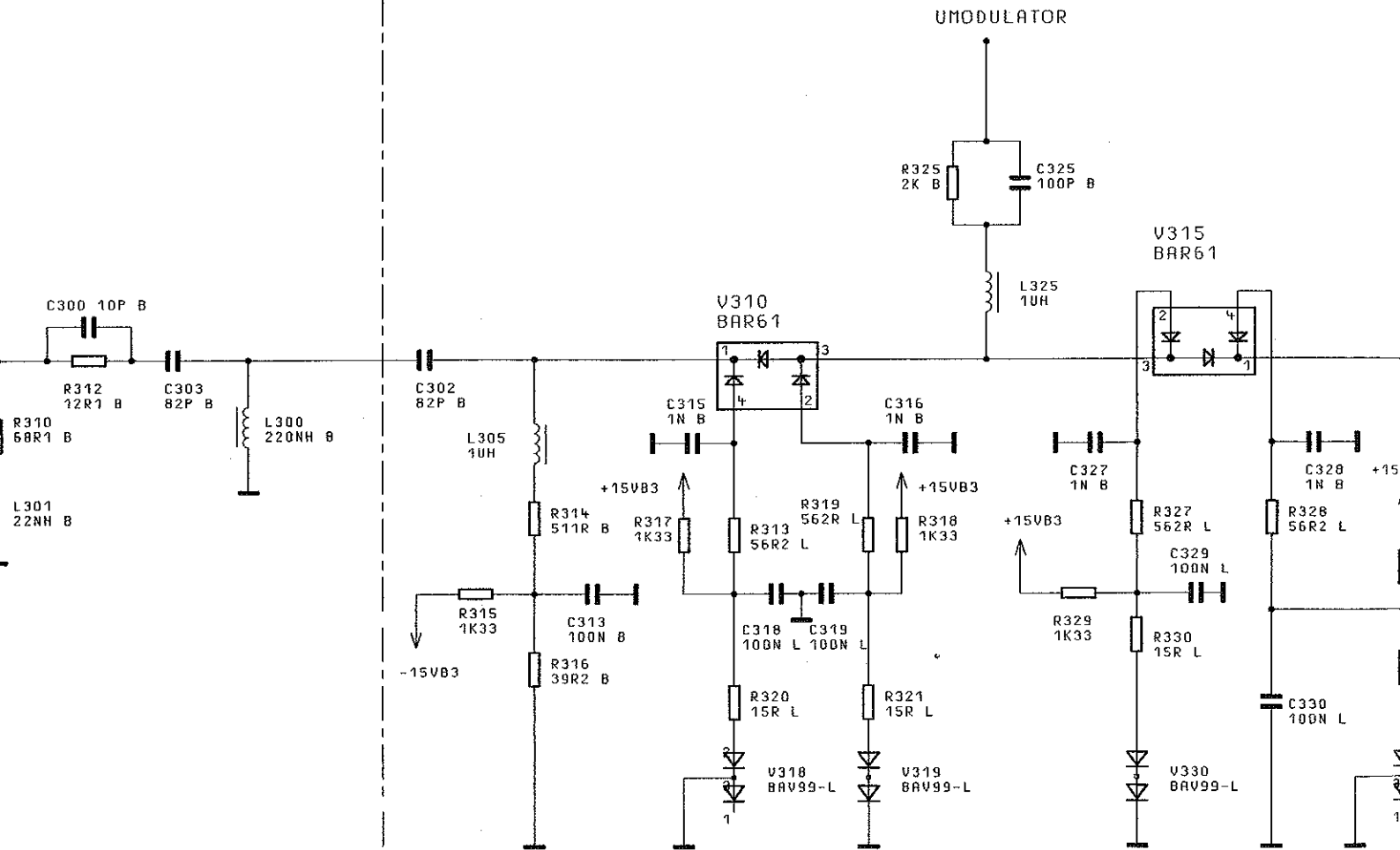

N.F. = NOT FIT

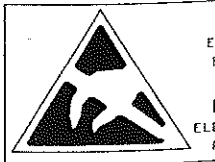

MP.-KOMPENSATION

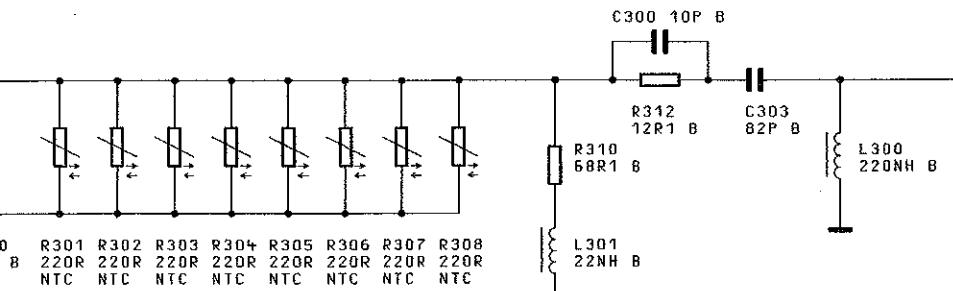

AM MODULATOR

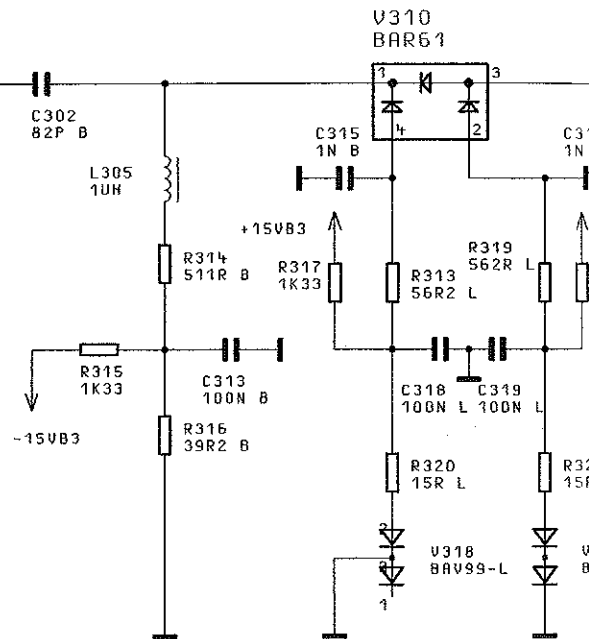

TEMP.-KOMPENSATION

AM M

X224 1

FSYN
6...1208M
65...1040MHZ

R300	R301	R302	R303	R304	R305	R306	R307	R308
27R B	220R	220R	220R	220R	220R	220R	220R	220R
6HZ	NTC	NTC	NTC	NTC	NTC	NTC	NTC	NTC

C300 10P B

R312
12R1 B

C303
82P B

L300
220NH B

C302
82P B

L301
10H

R310
68R1 B

L301
22NH B

R315
1K33

-15VB3

FUER DIESE UNTERLAGE
BEHALTEN WIR UNS ALLE RECHTE VOR

ZEICHN.-NR.



LP SELECT

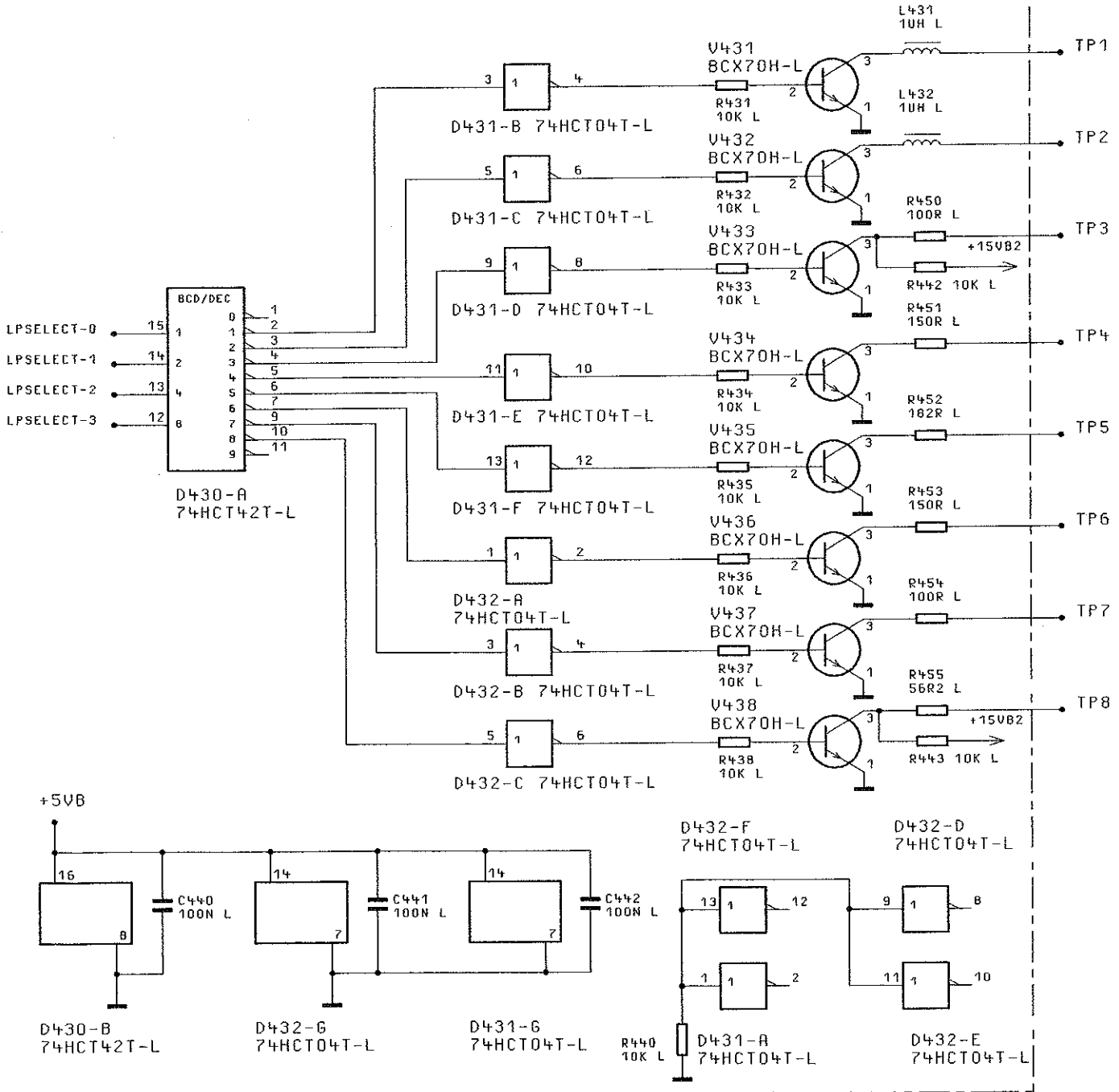

BINDENDE ANGABEN UEBER VARIANTEN,
TRIMMWERTE, BAUTEILWERTE UND
NICHT BESTUECKTE BAUTEILE SIEHE SA.

FOR BINDING INFORMATION ON MODELS,
TRIMMING AND COMPONENTS VALUES AND
NONFITTED COMPONENTS SEE PARTS LIST.

04/01	10.03.97	E I	MENP	TAG	NAME	BENENNUNG
			BEARB.		E I	AUSGANGSTEIL 1.046GHZ OUTPUT UNIT 1.046GHZ
			GEPR.			
			NORM			
			PLOTT	10.03.97		
04/	11.07.96	DR				ZEICHN.-NR.
REND IND.	RENDERUNGS- MITTEILUNG	DATUM	NAME	ROHDE&SCHWARZ		1062.6209.015
			ZU GERÄT	SMY	REG.I.V.	1062.5502
					ERSTE Z.	1062.5502

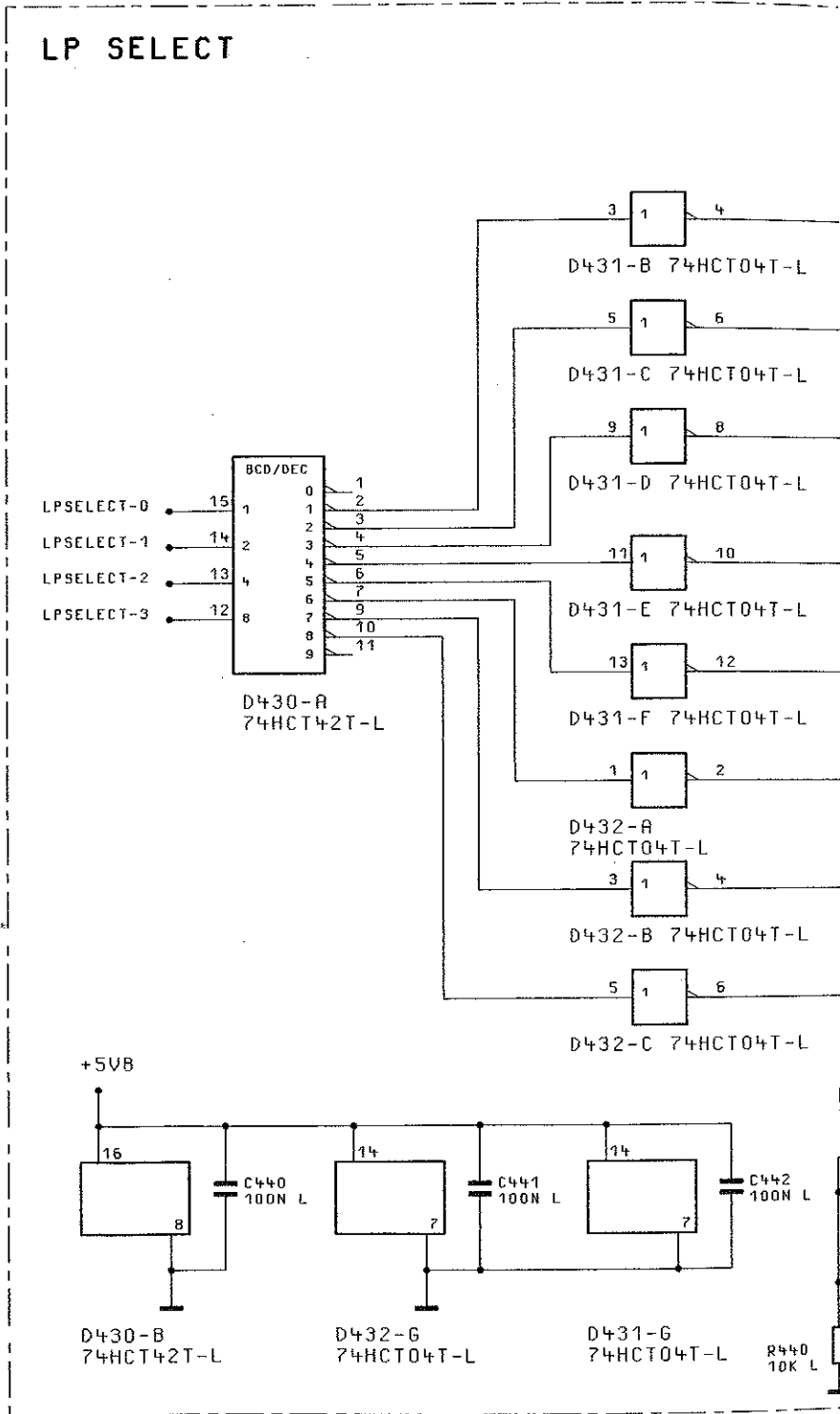
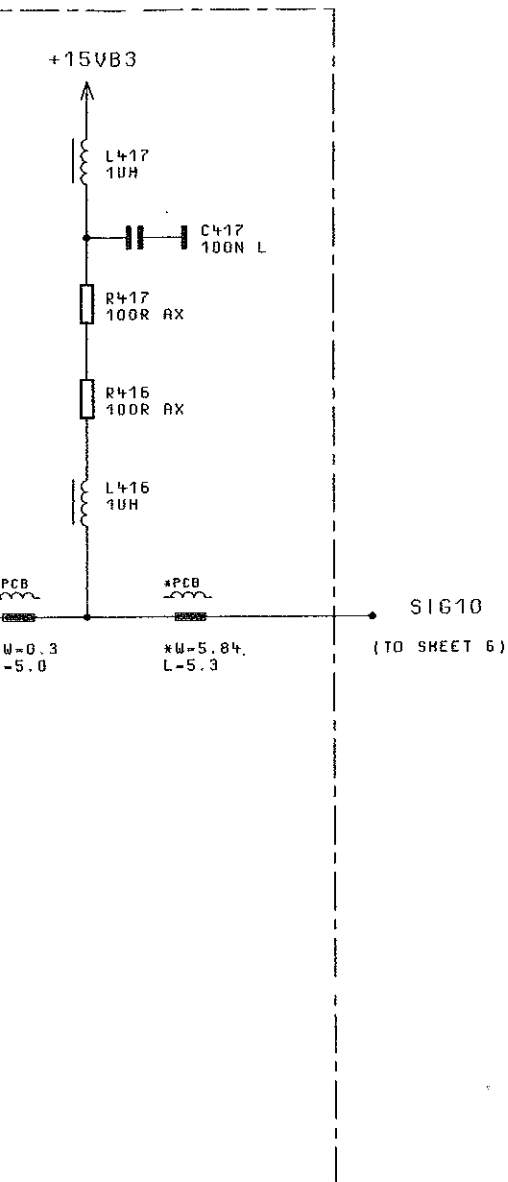

BINDENDE ANGABEN UEBER VARIANTEN,
TRIMMWERTE, BAUTEILWERTE UND
NICHT BESTUECKTE BAUTEILE SIEHE SA.

FOR BINDING INFORMAT
TRIMMING AND COMPONENTS
NONFITTED COMPONENTS

N.F. = NOT FITTED / NICHT BESTUECKT

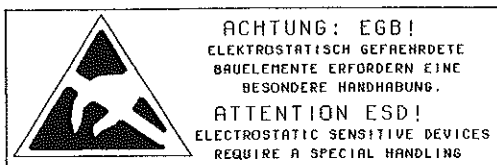

04/01		10.03.97	EI	MENP	TAG	NARE
				BEARB.		EI
				GEPR.		
				NORM		
				PLOTT	10.03.97	
04/		11.07.96	DR	ROHDE & SCHWARZ		
REND. IND.	ÄNDERUNGS- MITTEILUNG	DATUM	NAMEN			
				ZU GERÄT	SMY	

B3 RF AMPLIFIER 3

PRE

R411
1K5 L

C410
1N L

L410
680NH

*PCB C412
220P B

15VB3

414 *PCB *PCB
*W=3.135 *W=0.3
L=12.4 L=4.7

N410
MSA1105-B

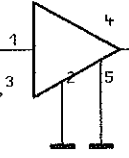

+15VB3

L417
10H

C417
100N L

R417
100R AX

R416
100R AX

L416
10H

*PCB
*W=0.3
L=5.0

*PCB
*W=5.84
L=5.3

SIG10
(TO SHEET 6)

LP SELECT

- LPSELECT-0
- LPSELECT-1
- LPSELECT-2
- LPSELECT-3

+5VB

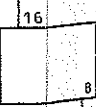

D430-B
74HCT42T

N.F. = NOT FITTED / NICHT BESTUECKT

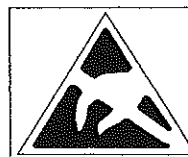

ACHTUNG: EGB!
ELEKTROSTATISCH GEFÄHRDETE
BAUELEMENTE ERFORDERN EINE
BESONDERE HANDHABUNG.
ATTENTION ESD!
ELECTROSTATIC SENSITIVE DEVICES
REQUIRE A SPECIAL HANDLING

BINDEND
TRIMMERT
NICHT BES

04/01	
04/	
BEND.	
IND.	

B3 RF AMPLIFIER 3

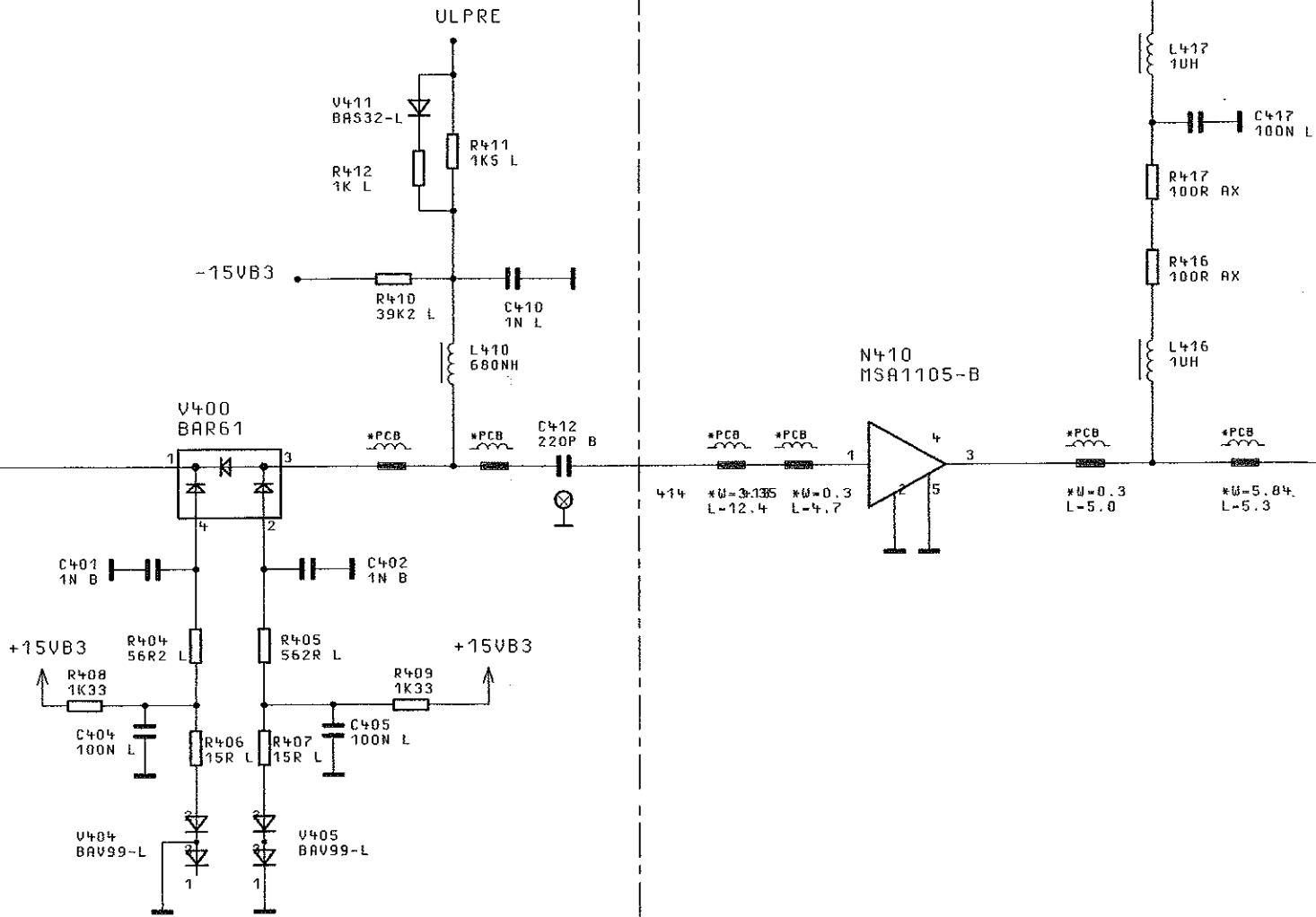

PRESET

B3

RF AMPLIFIER 3

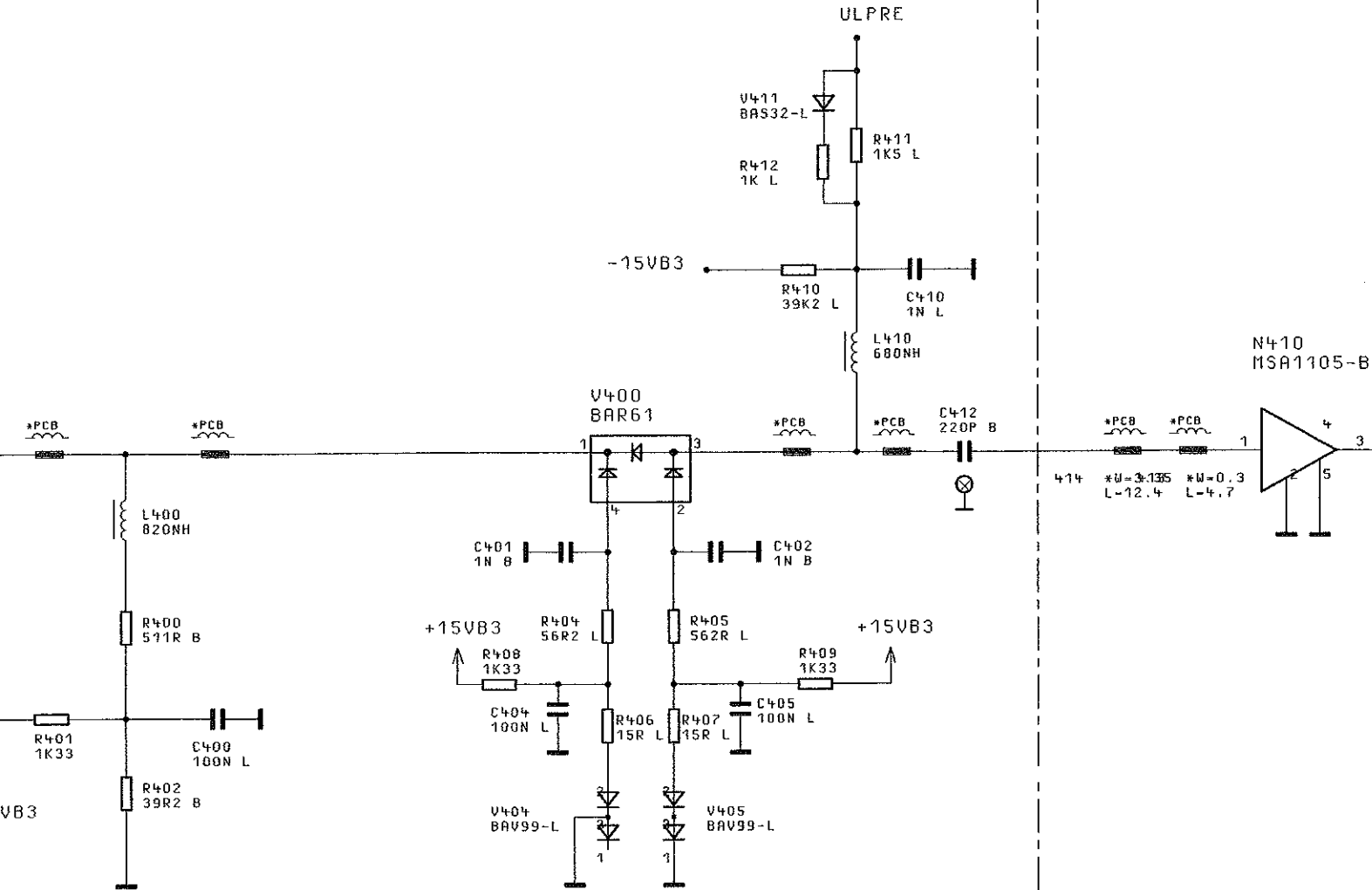

1

2

3

4

F

E

D

C

B

A

LEVEL PRESET

RFLOLEV
(FROM SHEET 4)

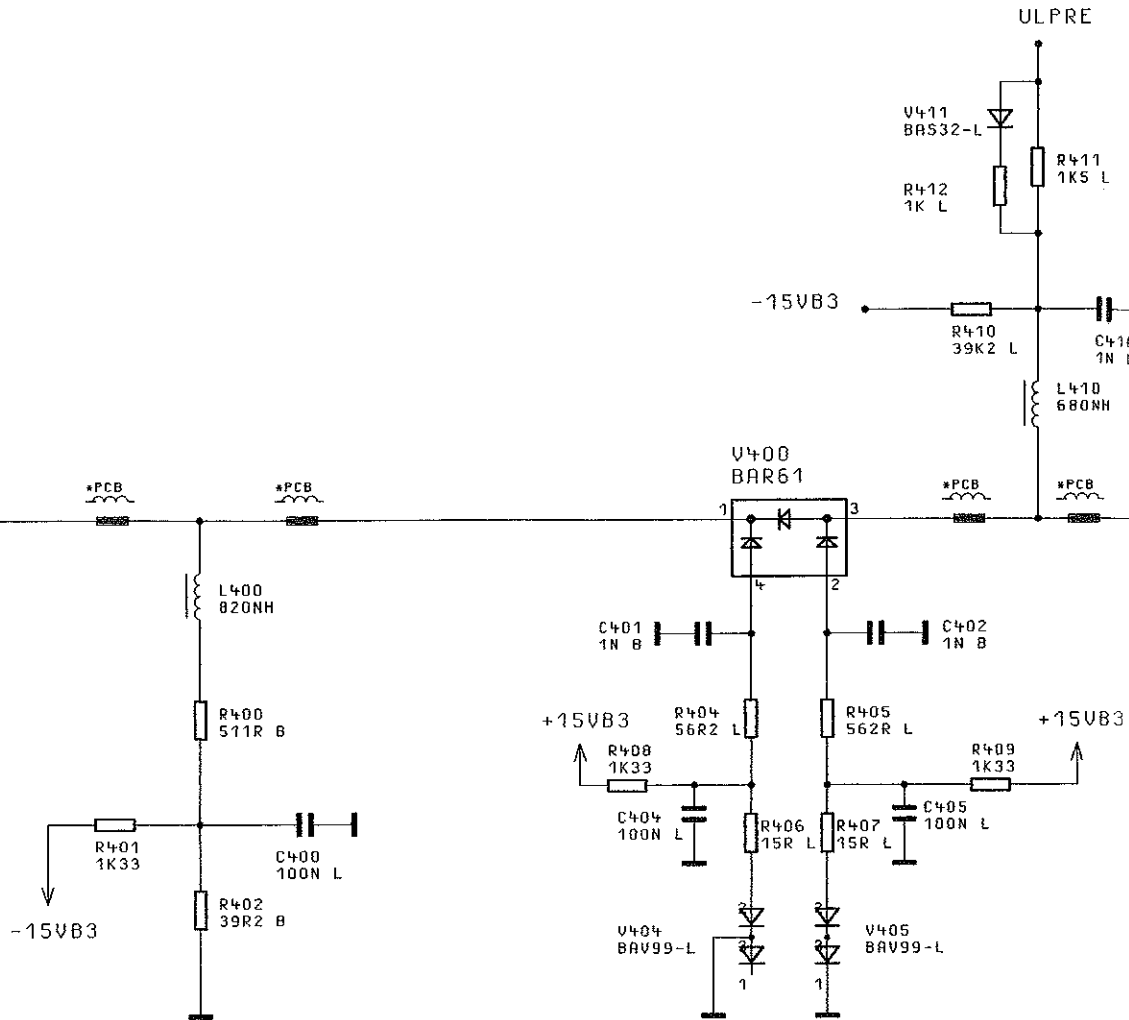

FUER DIESE UNTERLAGE
BEHALTEN MIR UNS ALLE RECHTE VOR

ZEICHN.-NR.



B2

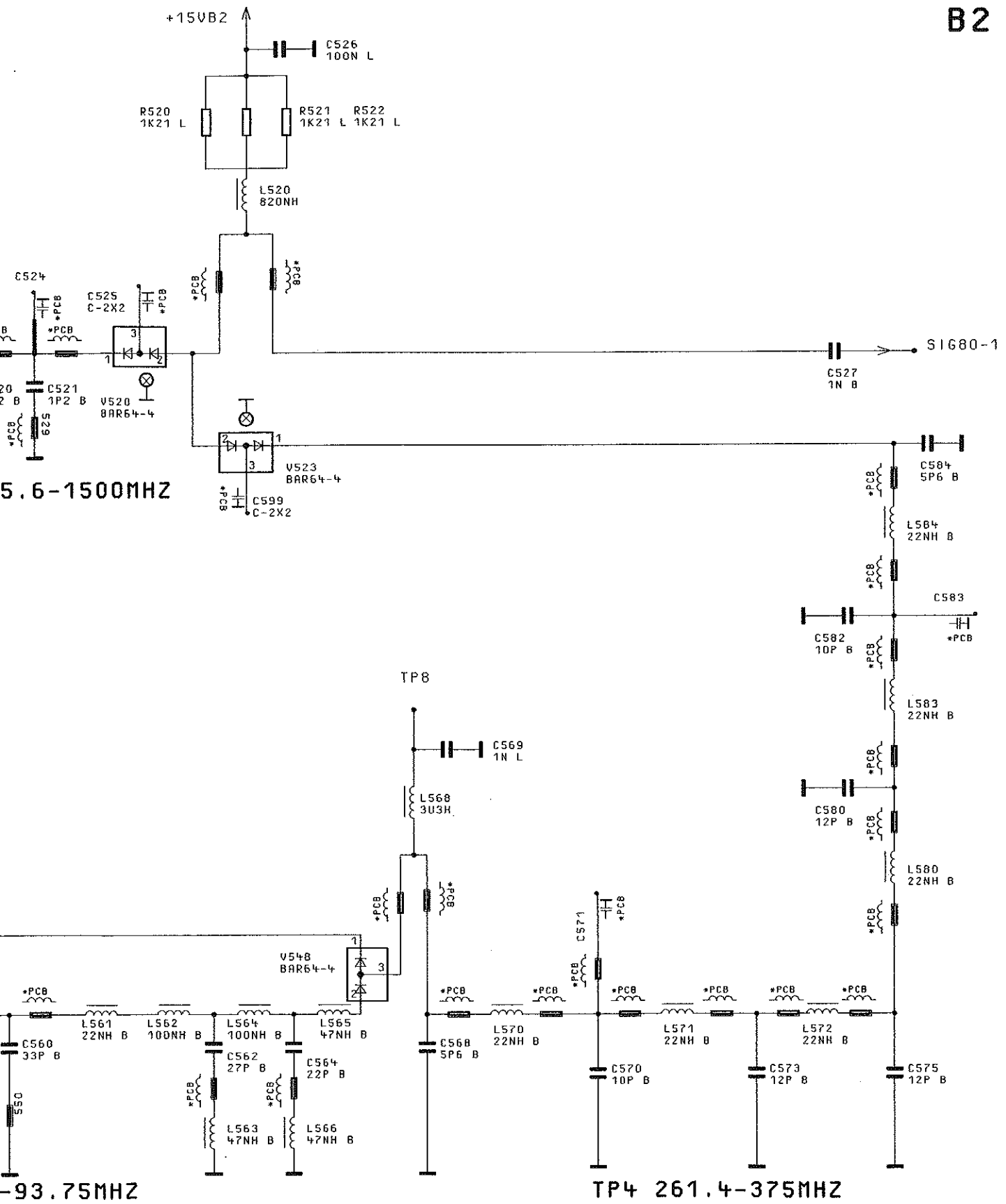

5.6-1500MHZ

-93.75MHZ

TP4 261.4-375MHZ

04/01	10.03.97	E1	MENP	TAG	NAME	BENENNUNG
			BEARB.		E1	AUSGANGSTEIL 1.046GHZ OUTPUT UNIT 1.046GHZ
			GEPR.			
			NORM			
			PLOTT	10.03.97		
04/	11.07.96	DR	 ROHDE & SCHWARZ	ZEICHN.-NR.		BLATT-NR.
REND. IND.	RENDERUNGS-MITTEILUNG	DATUM		NAME	1062.6209.01S	
			ZU GERÄT	SMY	REG. I.V.	1062.5502
					ERSTE Z.	1062.5502

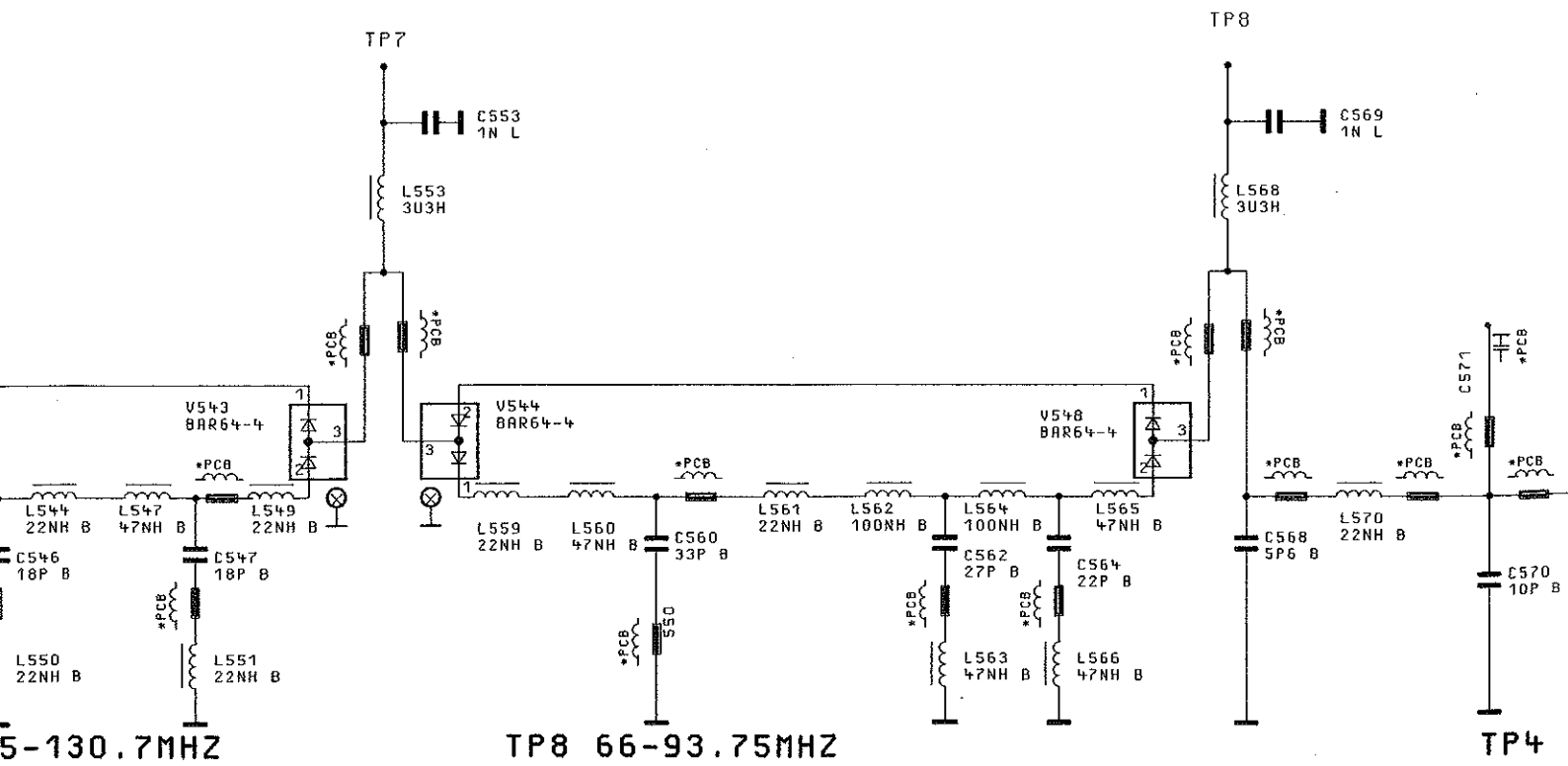
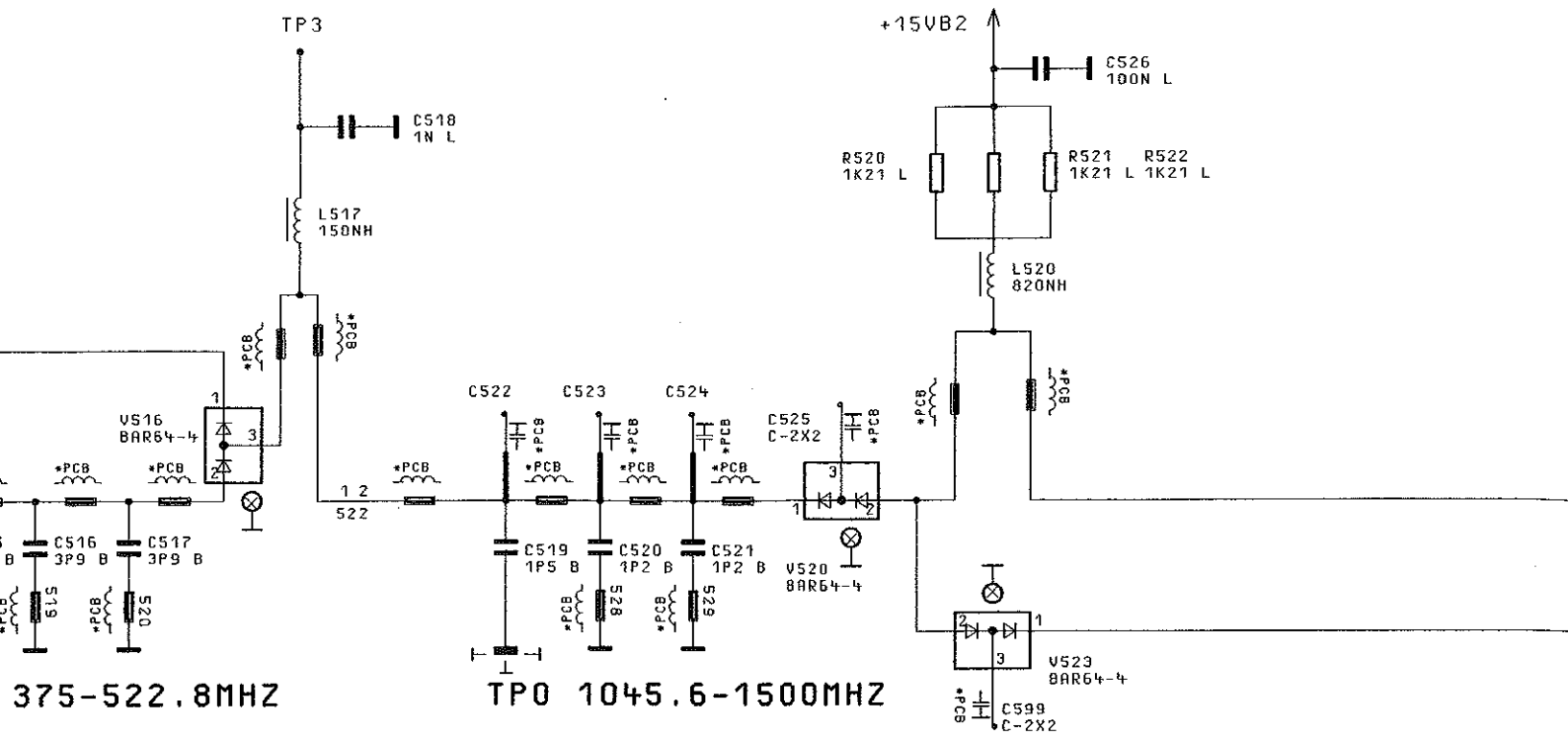

BESTUECKT

BINDENDE ANGABEN UEBER VARIANTEN, TRIMMWERTE, BAUTEILWERTE UND NICHT BESTUECKTE BAUTEILE SIEHE SA.

EGB!
GEFAHREDETE
ERFORDERN EINE
HANDHABUNG.
ESD!
SENSITIVE DEVICES
SPECIAL HANDLING

FOR BINDING INFORMATION ON MODELS, TRIMMING AND COMPONENTS VALUES AND NONFITTED COMPONENTS SEE PARTS LIST.

04/01	10.03.97	E I	MENP	TAG	NAME	BENENNUNG
			BEARB.		E I	
			GEPR.			
			NORM			
			PLOTT	10.03.97		
04/	11.07.96	DR				ZEICHNUNG
REND. IND.	ÄNDERUNGS-MITTEILUNG	DATUM	NAME			REG. I. V.
						ZU GERÄT

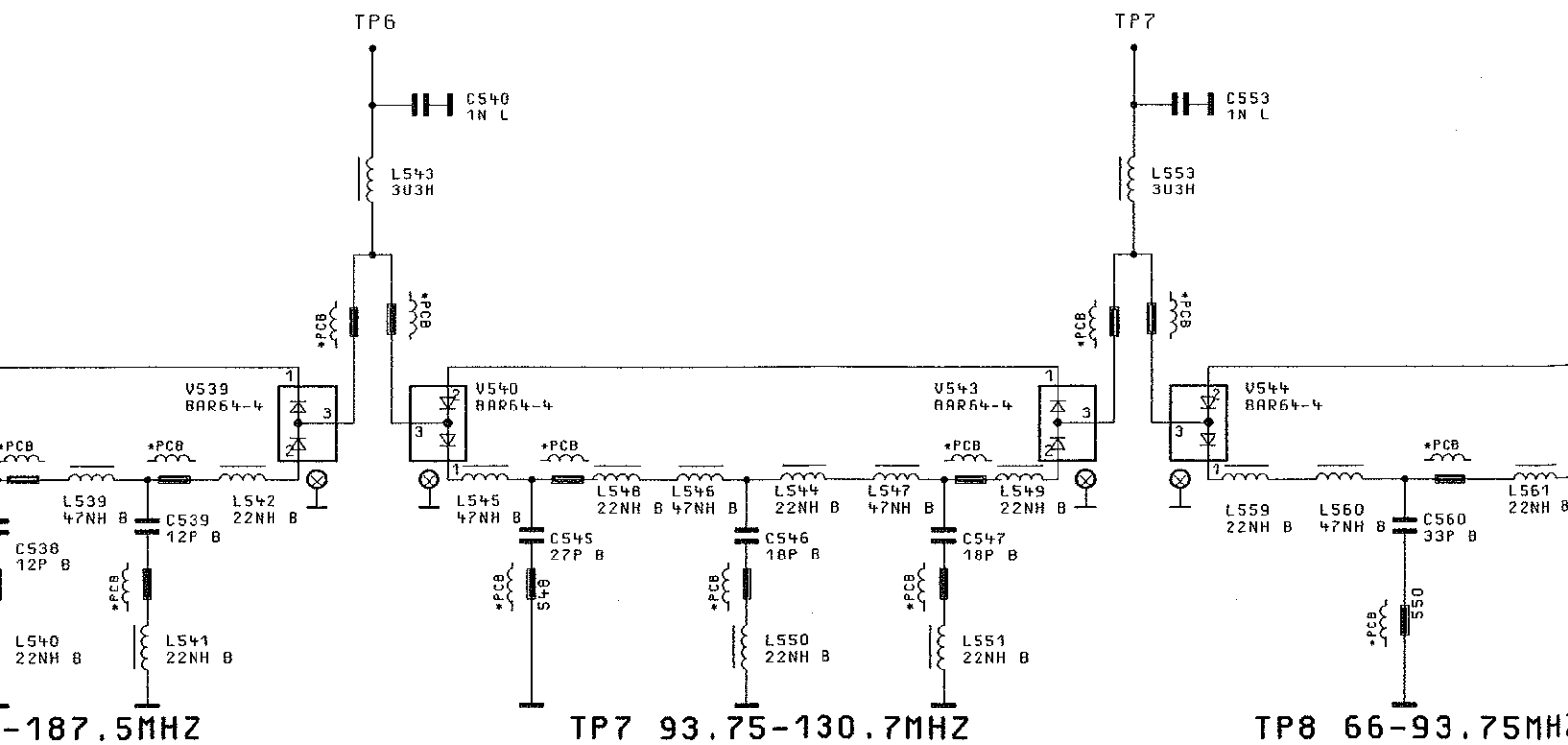
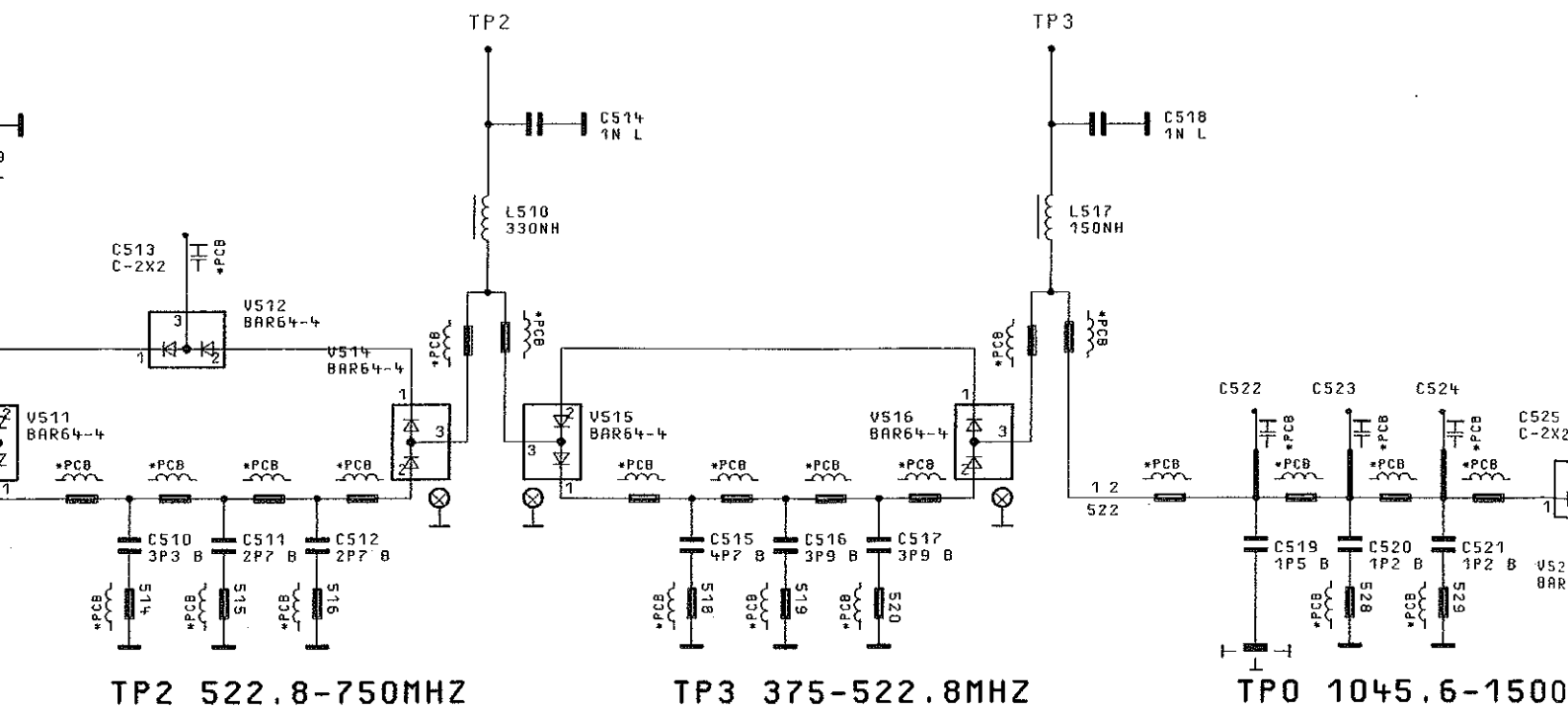

N.F. - NOT FITTED / NICHT BESTUECKT

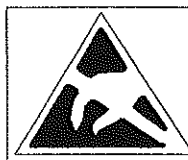

ACHTUNG: EGB!
 ELEKTROSTATISCH GEFÄHRDETE
 BAUELEMENTE ERFORDERN EINE
 BESONDERE HANDHABUNG.
ATTENTION ESD!
 ELECTROSTATIC SENSITIVE DEVICES
 REQUIRE A SPECIAL HANDLING

BINDENDE ANGABEN UEBER VARIANTEN,
 TRIMMWERTE, BAUTEILWERTE UND
 NICHT BESTUECKTE BAUTEILE SIEHE SA.

FOR BINDING INFORMATION ON MODELS,
 TRIMMING AND COMPONENTS VALUES AND
 NONFITTED COMPONENTS SEE PARTS LIST.

04/01
 04/
 AEND
 IND.

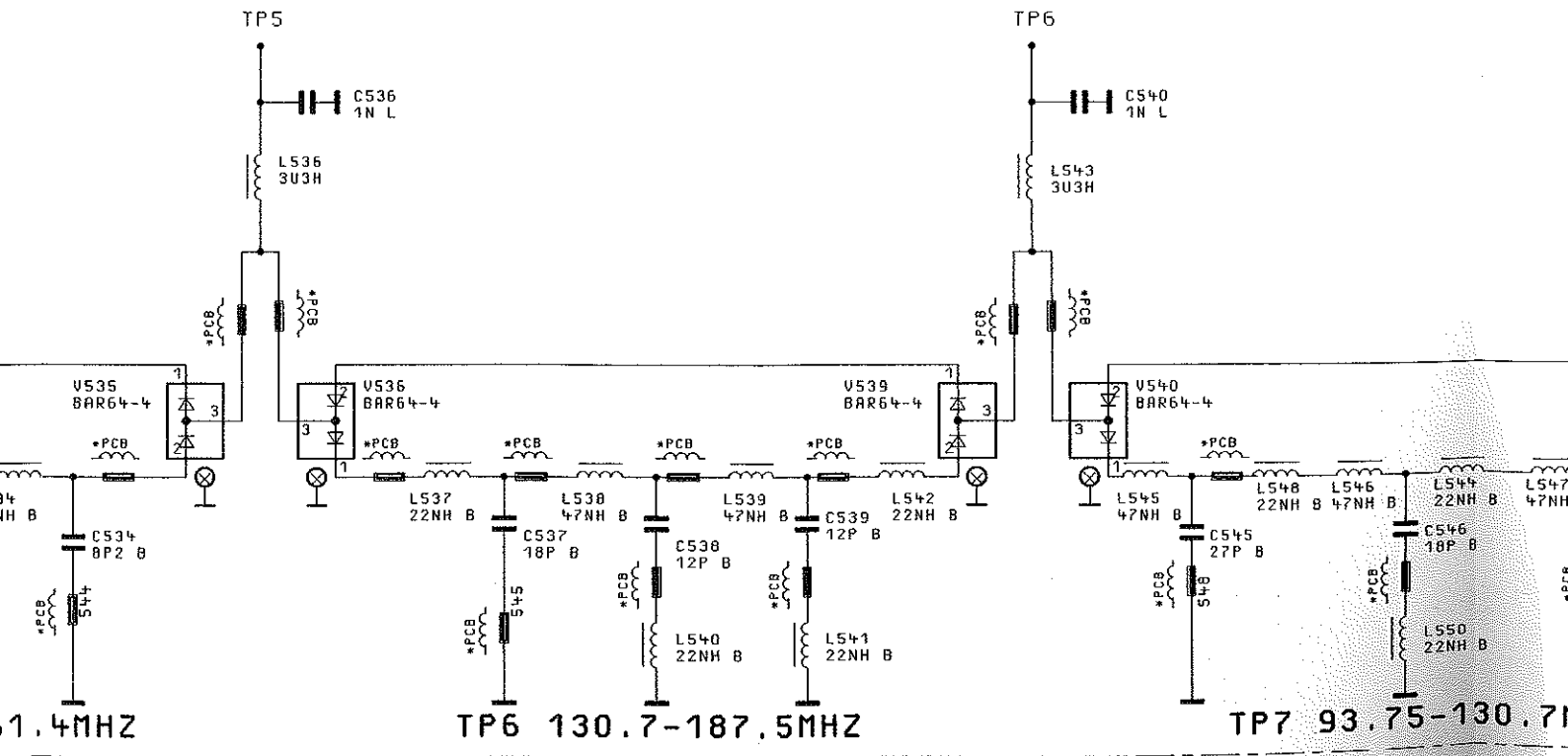
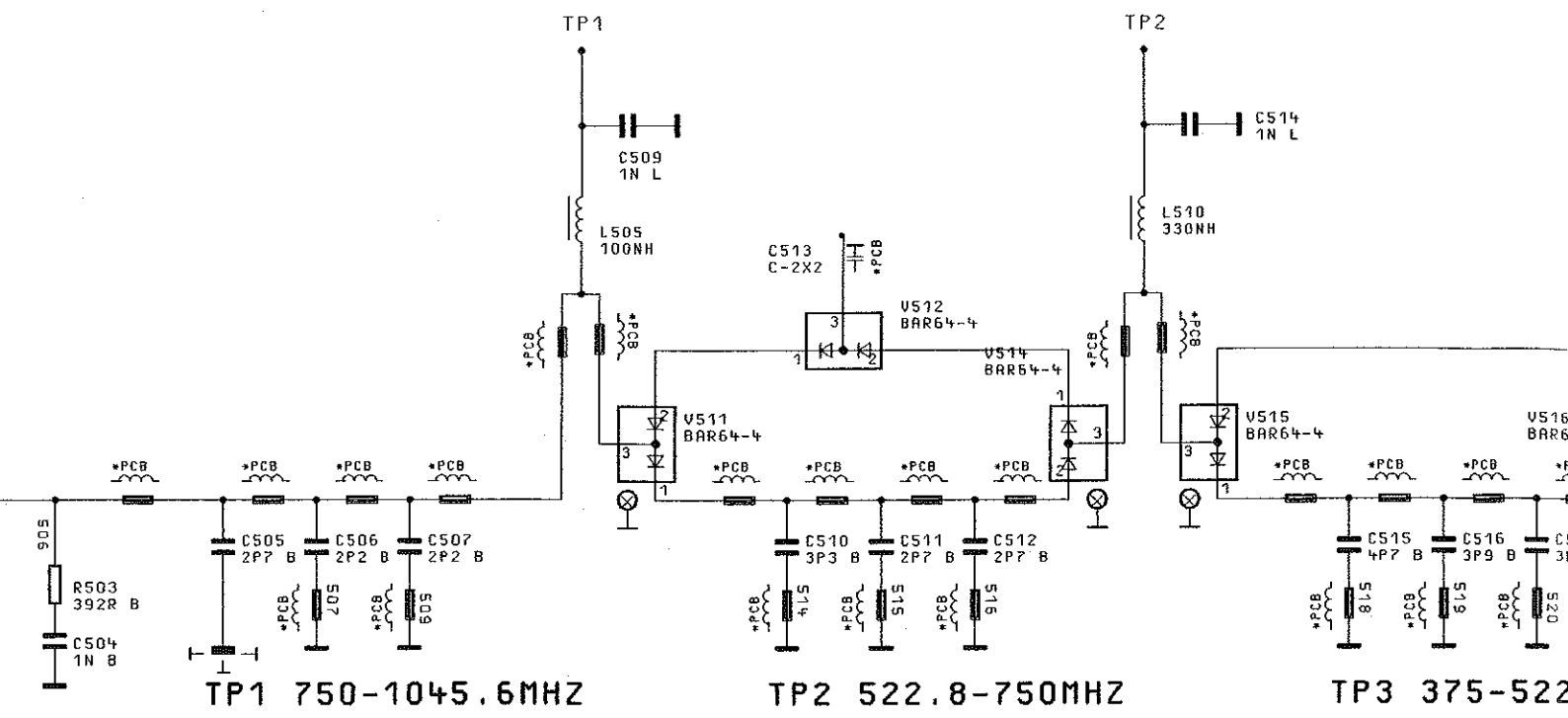

15V82

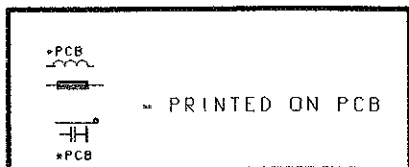

N.F. = NOT FITTED / NICHT BESTUECKT

ACHTUNG: ESD!
ELEKTROSTATISCH GEFÄHRDETE
BAUELEMENTE ERFORDERN EINE
BESONDERE HANDLUNG.
ATTENTION ESD!
ELECTROSTATIC SENSITIVE DEVICES
REQUIRE A SPECIAL HANDLING

HARMONIC FILTERS

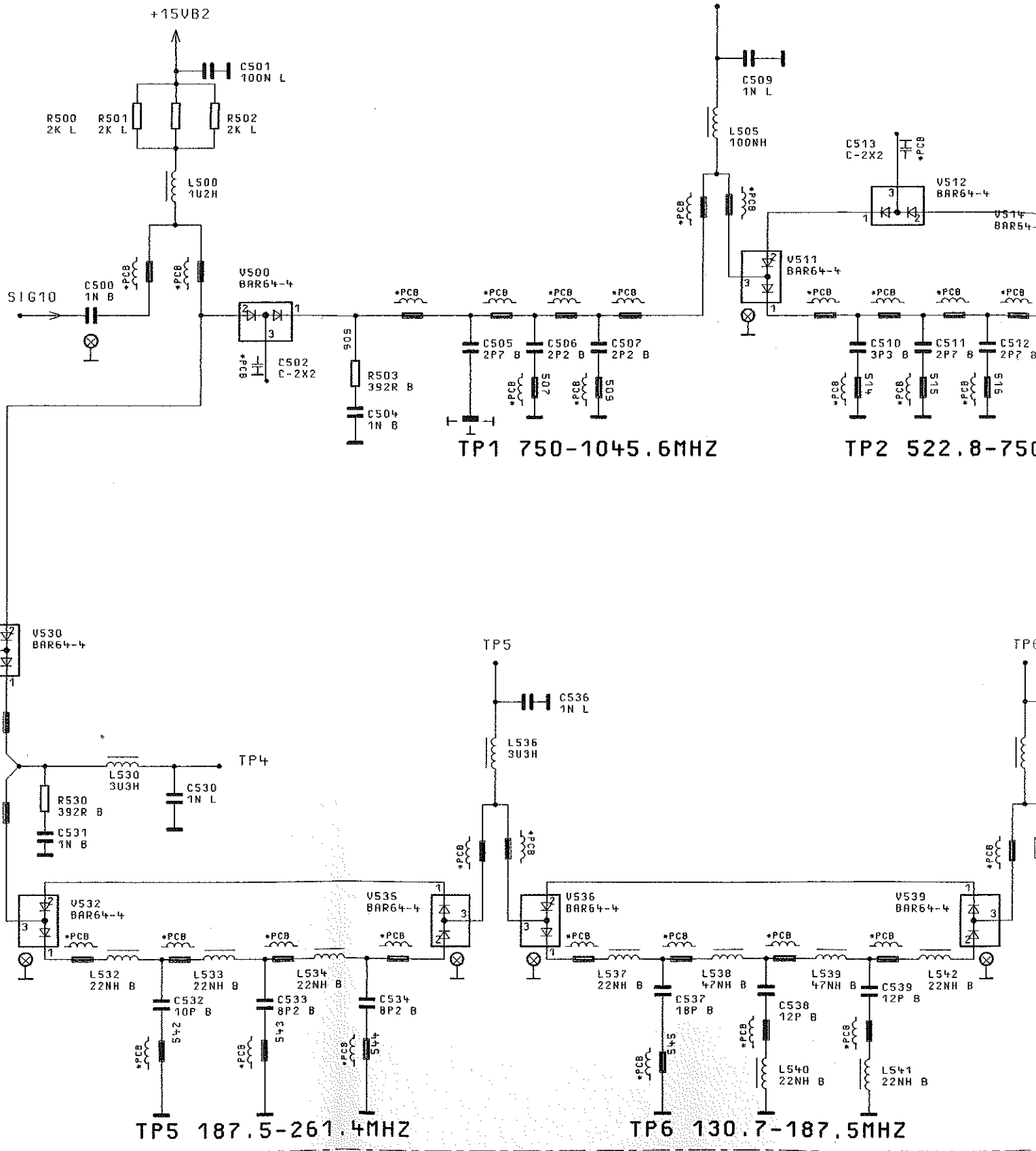

- PRINTED ON PCB

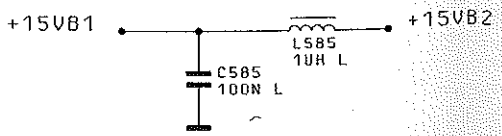

HARMONIC FILTERS

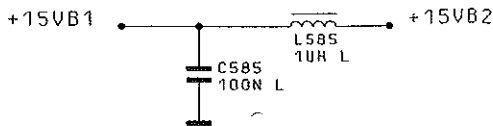
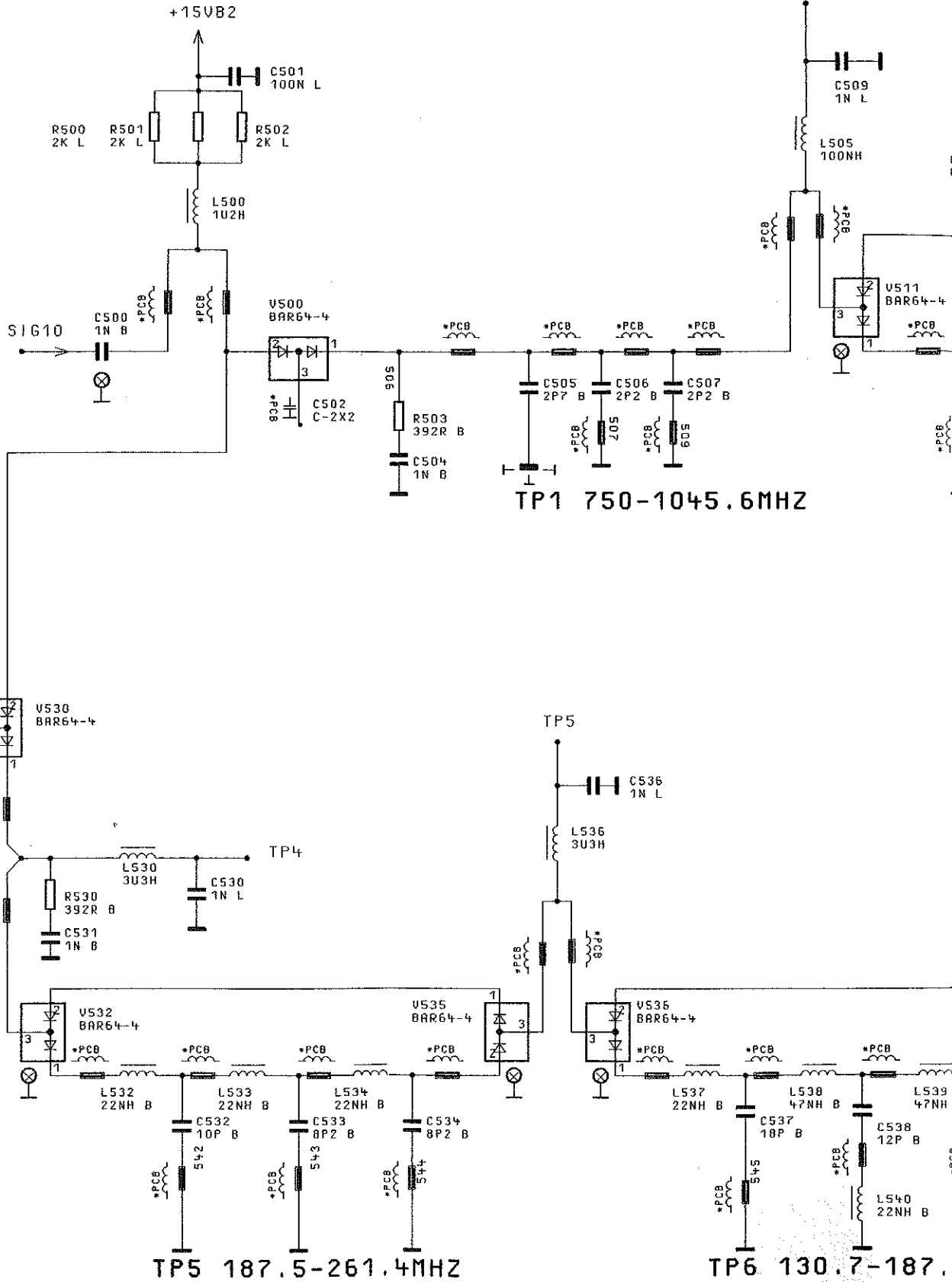

*PCB

— [Symbol] —

— [Symbol] —

*PCB

= PRINTED ON PCB

FÜR DIESE UNTERLAGE
BEHALTEN WIR UNS ALLE RECHTE VOR

ZEICHN.-NR.

R645
IF GAIN

AMPLIFIER

IF-LOWPASS
65MHZ

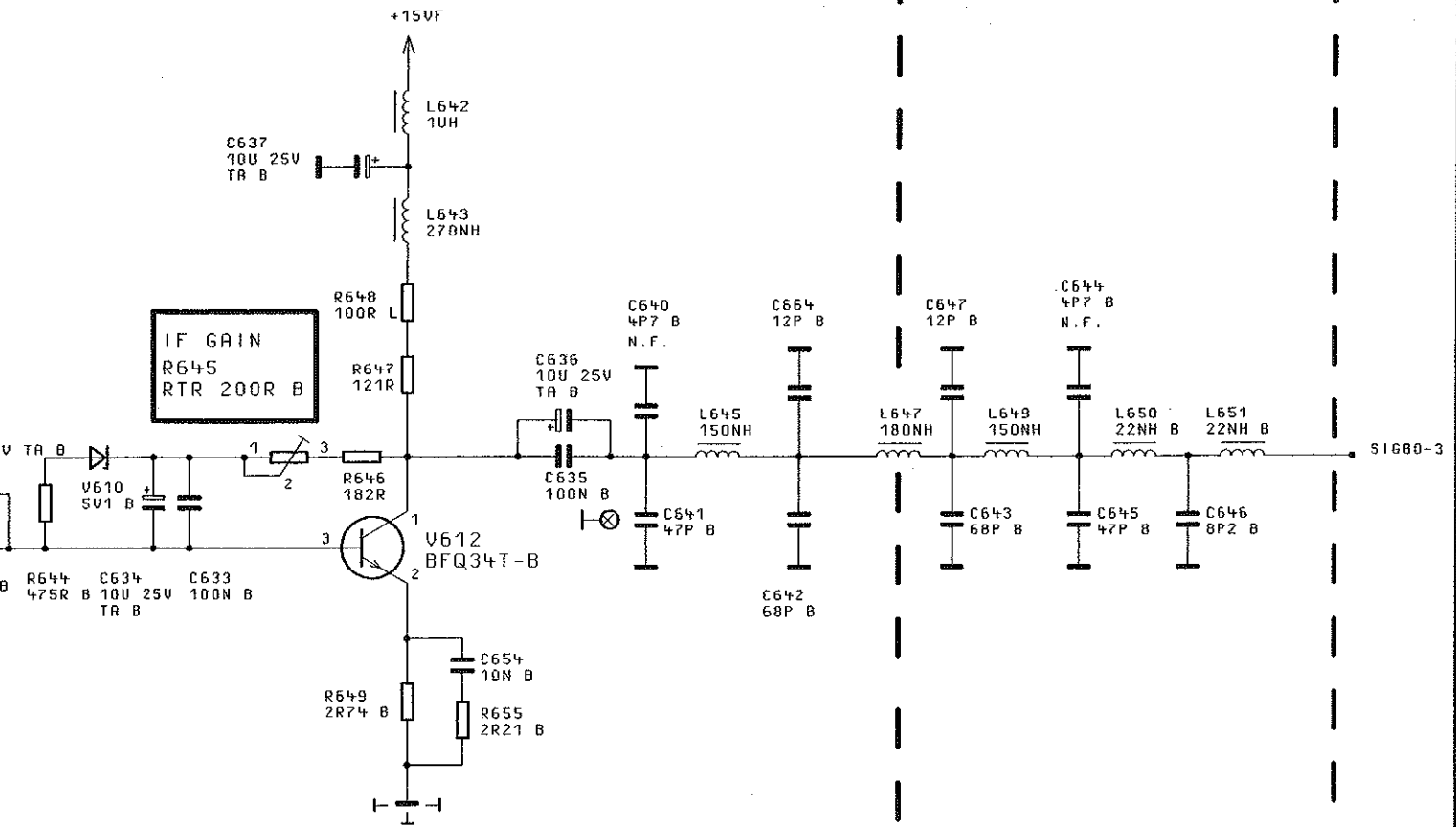

N.F. - NOT FITTED / NICHT BESTUECKT

SINDENDE ANGABEN UEBER VARIANTEN,
TRIMMWERTE, BAUTEILWERTE UND
NICHT BESTUECKTE BAUTEILE SIEHE SA.

FOR BINDING INFORMATION ON MODELS,
TRIMMING AND COMPONENTS VALUES AND
NONFITTED COMPONENTS SEE PARTS LIST.

04/01		10.03.97	EI	MENP	TAG	NAM	BENENNUNG		
				BEARB.		EI	AUSGANGSTEIL 1.046GHZ OUTPUT UNIT 1.046GHZ		
				GEPR.					
				NORM					
				PLOTT	10.03.97				
04/		11.07.96	DR	 ROHDE & SCHWARZ			ZEICHN.-NR.	BLATT-NR.	
REND. IND.	RENDERUNGS- MITTEILUNG	DATUM	NAM				1062.6209.015	7+	
				ZU GERAEZ	SMY	REG.-I.V.	1062.5502	ERSTE Z.	1062.5502

⊙ R645
IF GAIN

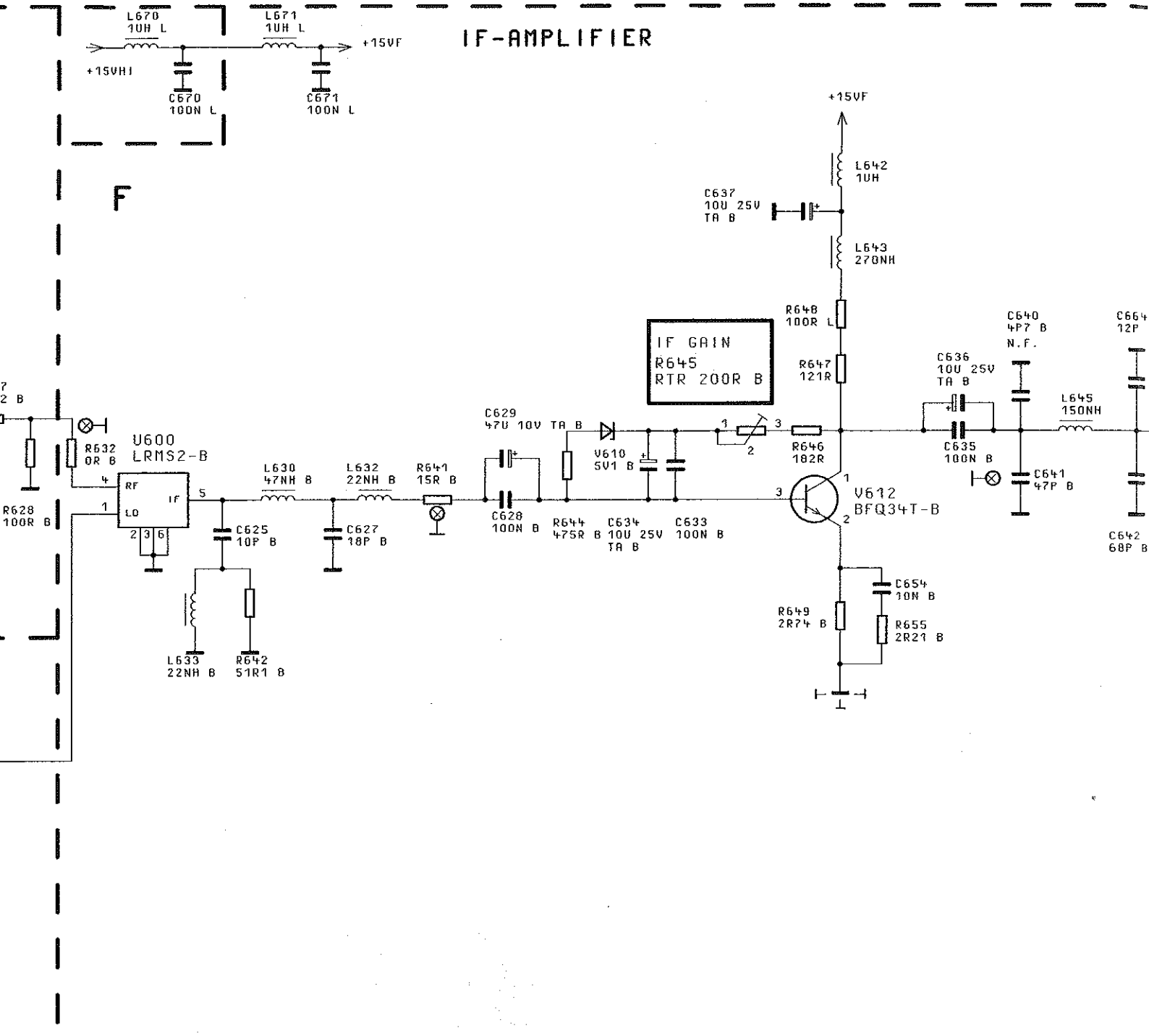

ACHTUNG: EGB!
ELEKTROSTATISCH GEFÄHRDETE
BAUELEMENTE ERFORDERN EINE
BESONDERE HANDHABUNG.
ATTENTION ESD!
ELECTROSTATIC SENSITIVE DEVICES
REQUIRE A SPECIAL HANDLING

N.F. - NOT FITTED / NICHT BESTUECKT

BINDENDE ANGABEN UEBER VARIANTEN,
TRIMMWERTE, BAUTEILWERTE UND
NICHT BESTUECKTE BAUTEILE SIEHE SA.

FOR BINDING IN
TRIMMING AND CO
NONFITTED COMP

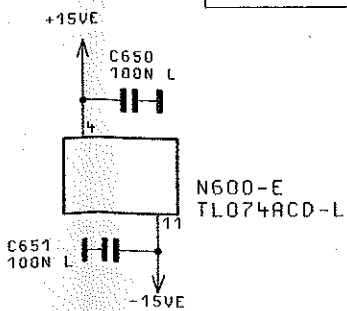

04/01		10.03.97	E I	MENP	TAG	NAME
				BEARB.		E I
				GEPR.		
				NDRR		
				PLOTT	10.03.97	
04/		11.07.96	DR			
REND. IND.	ÄNDERUNGS- MITTEILUNG	DATUM	NAME	ROHDE&SCHWARZ ZU GERRET SMY		

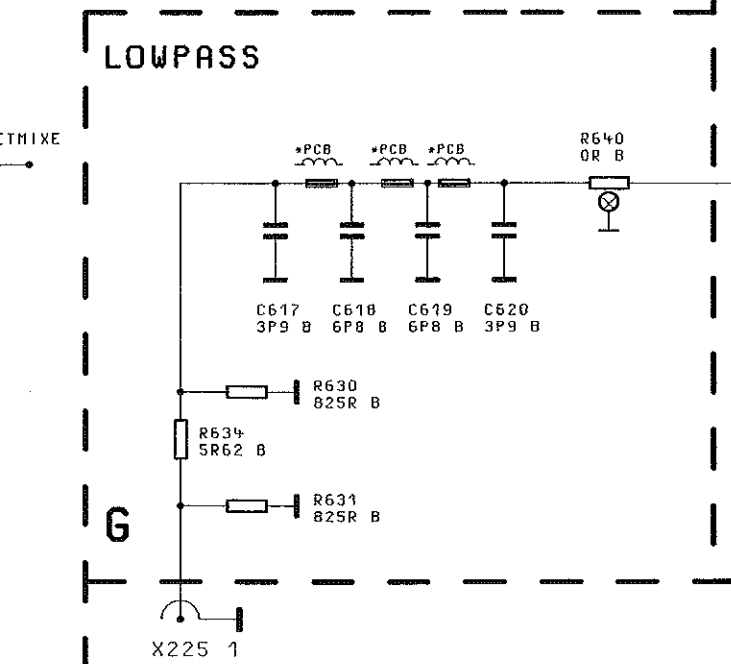
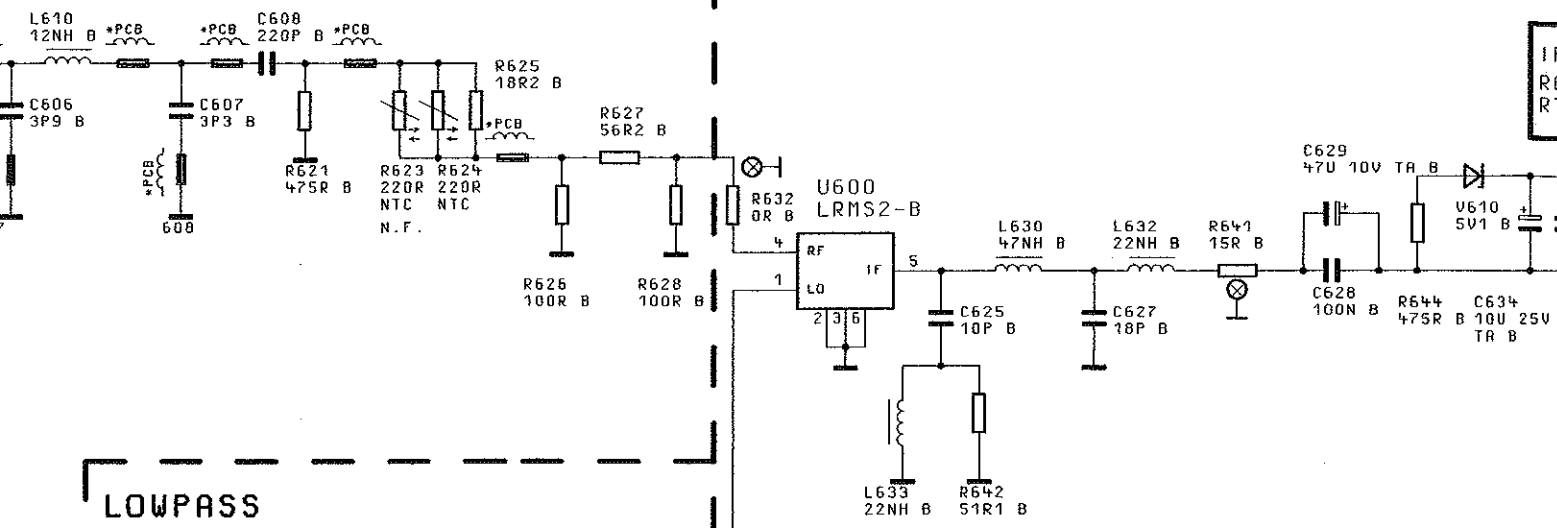
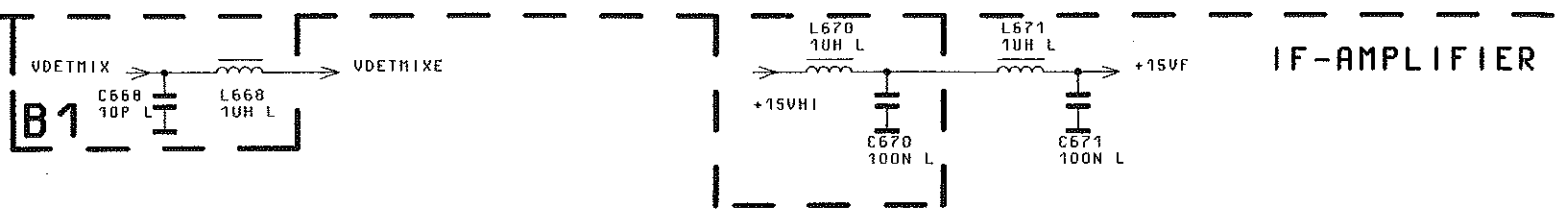

REF640
640MHZ
9...12DBM



ACHTUNG: EGB!
ELEKTROSTATISCH GEFÄHRDETE
BAUELEMENTE ERFORDERN EINE
BESONDERE HANDHABUNG.
ATTENTION ESD!
ELECTROSTATIC SENSITIVE DEVICES
REQUIRE A SPECIAL HANDLING

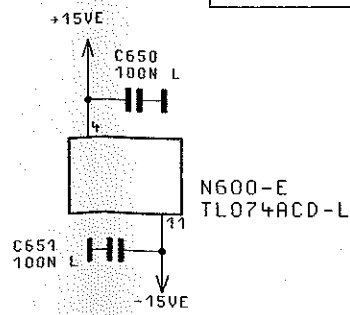
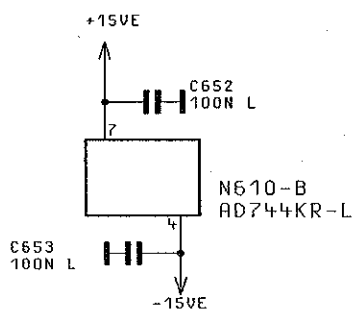

04/01	
04/	
REND.	
IND.	

P601 P628
P620 P621

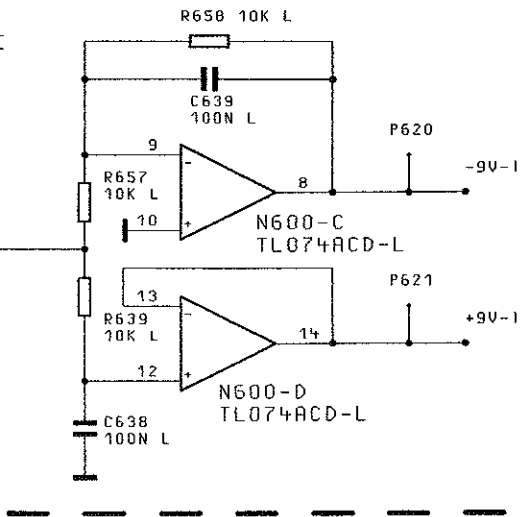
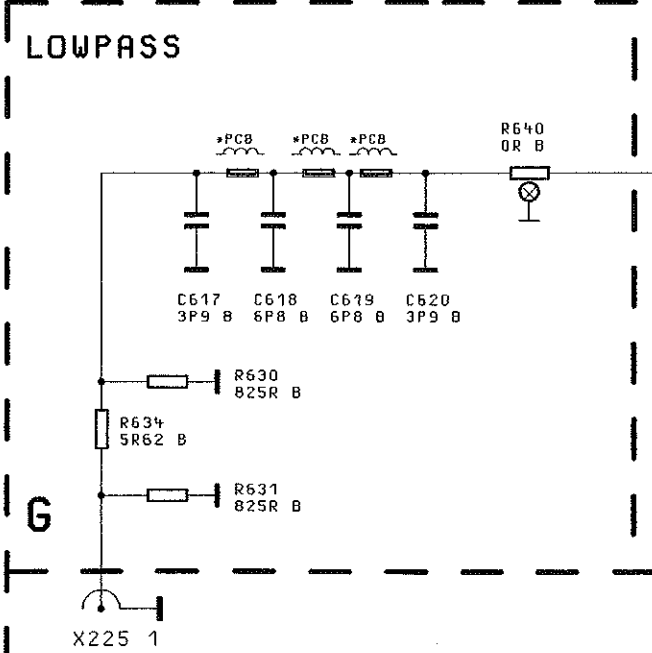
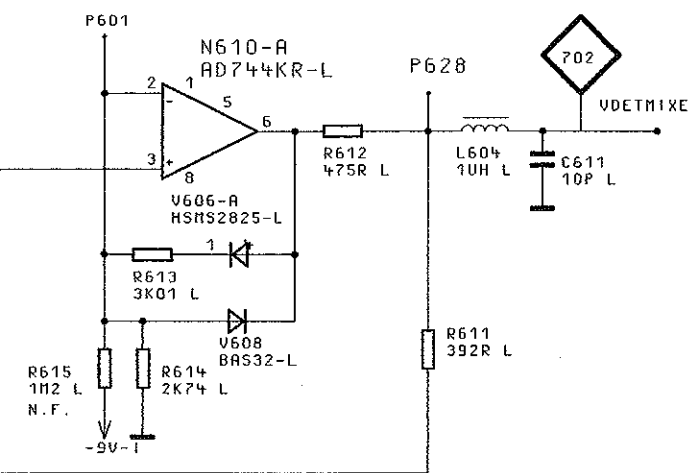
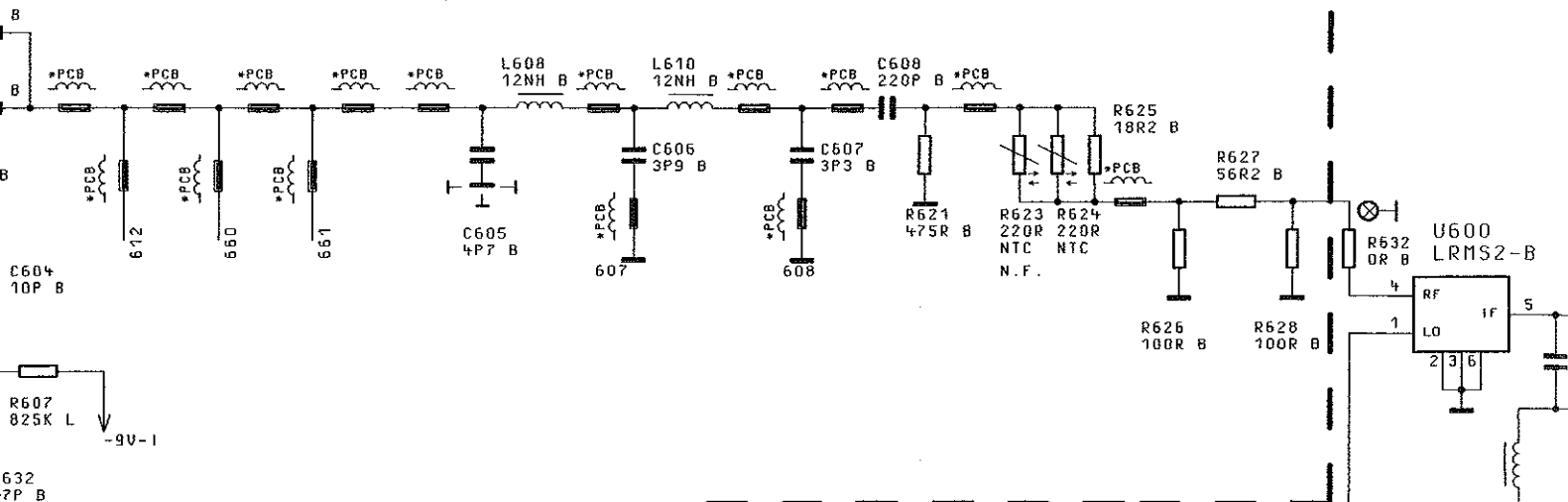
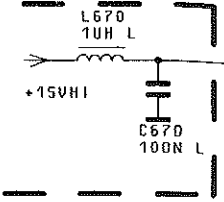
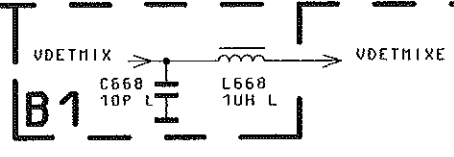
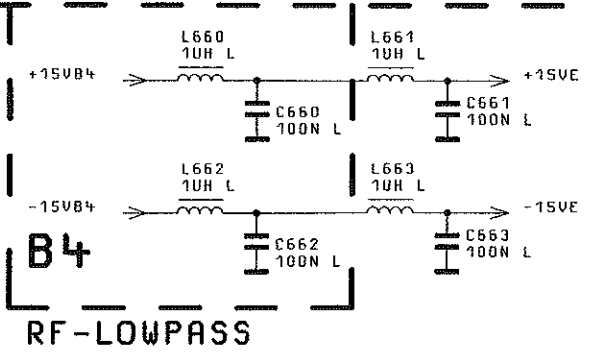

REF640
640MHZ
9...12DBM

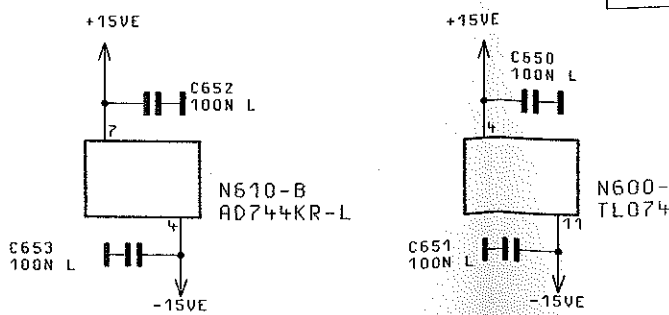

RF-AMPLIFIER 4
E

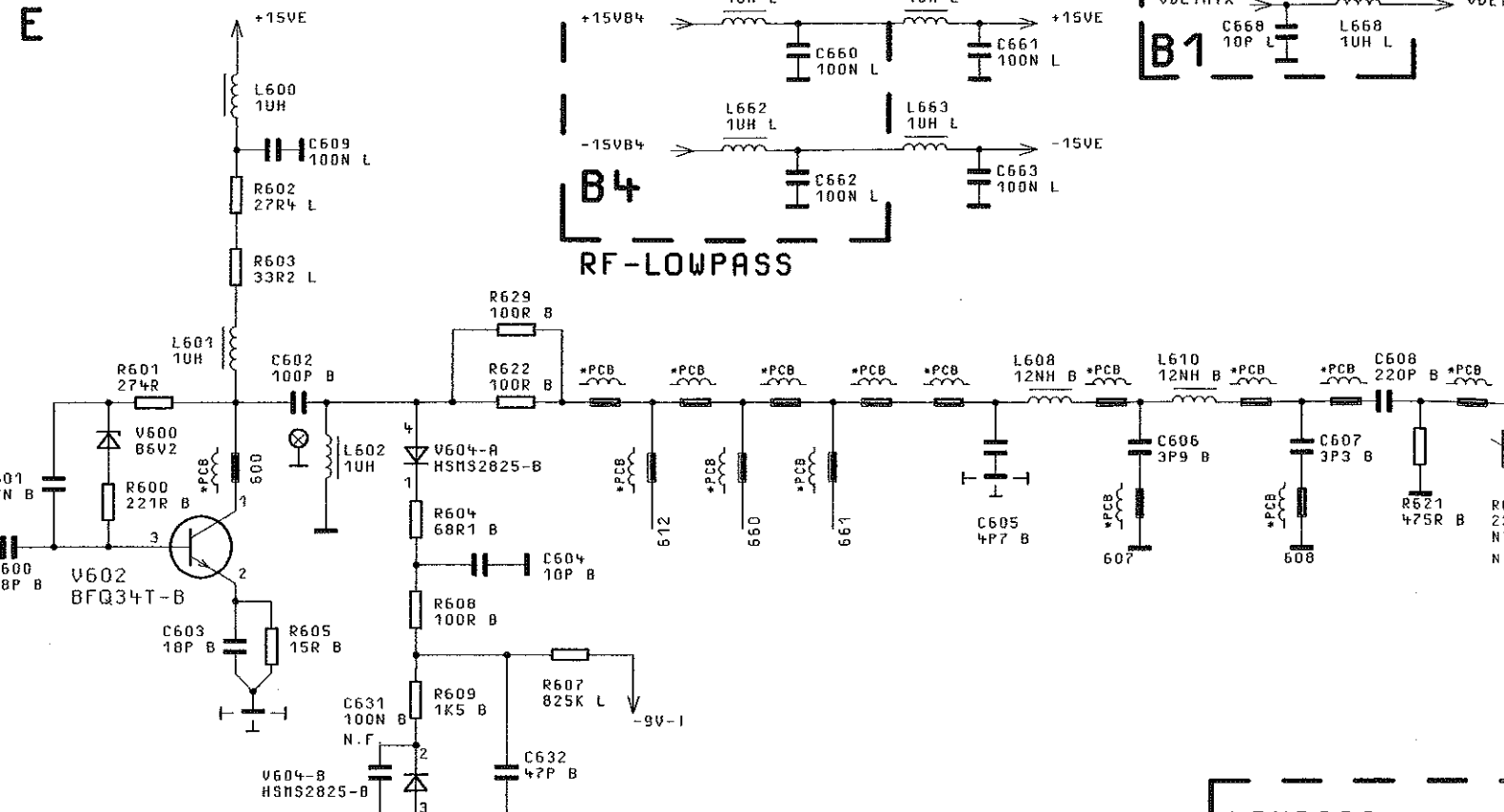

DETECTOR LINEARIZER

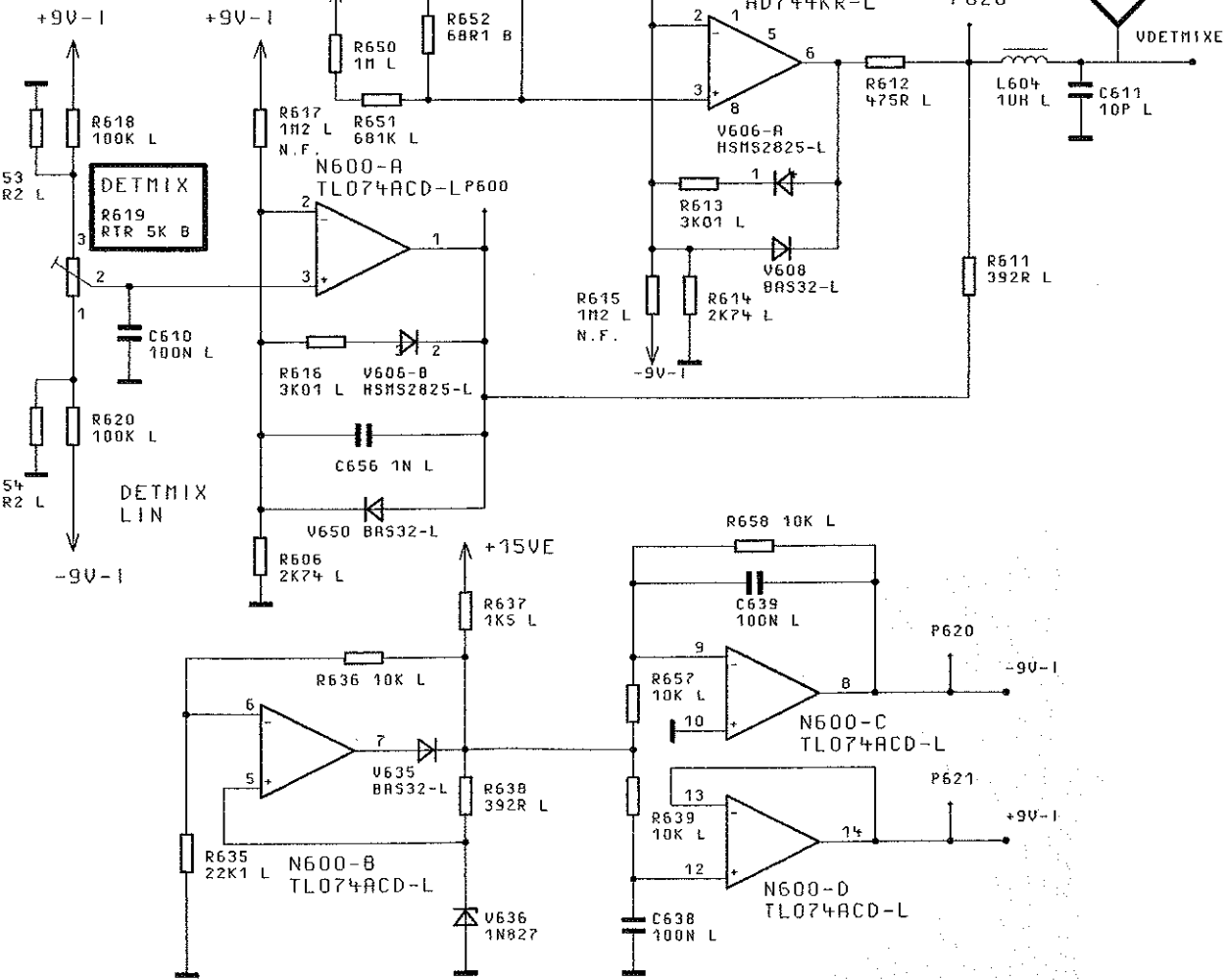

LOWPASS

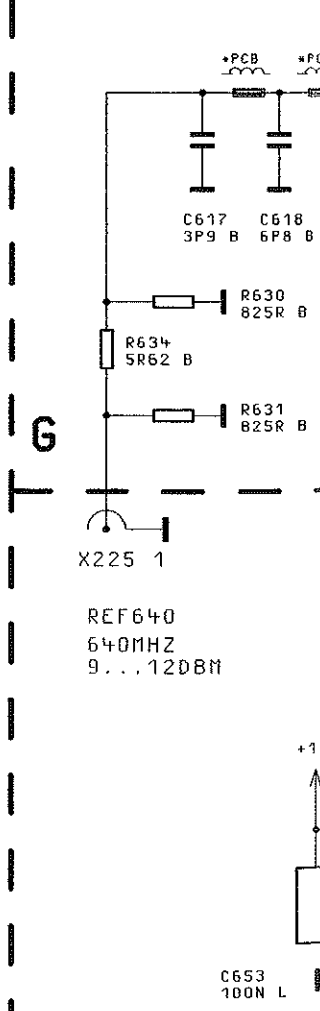

R619
DETMIX

P600

P601

P628

P620 P621

RF-AMPLIFIER 4

E

B4

RF-LOWPASS

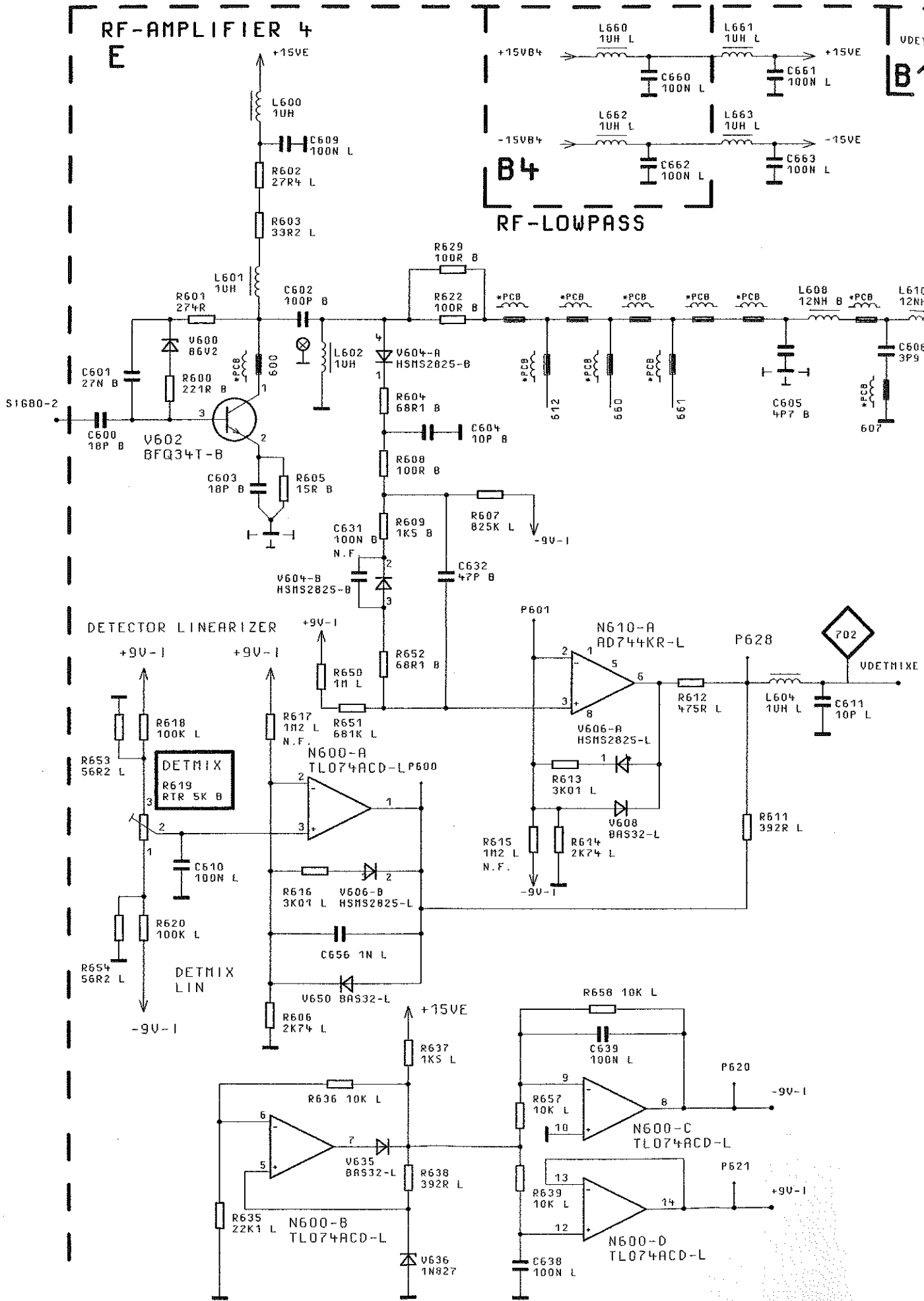

FUER DIESE UNTERLAGE
BEHALTEN WIR UNS ALLE RECHTE VOR

ZEICHN.-NR



SWITCH B

H

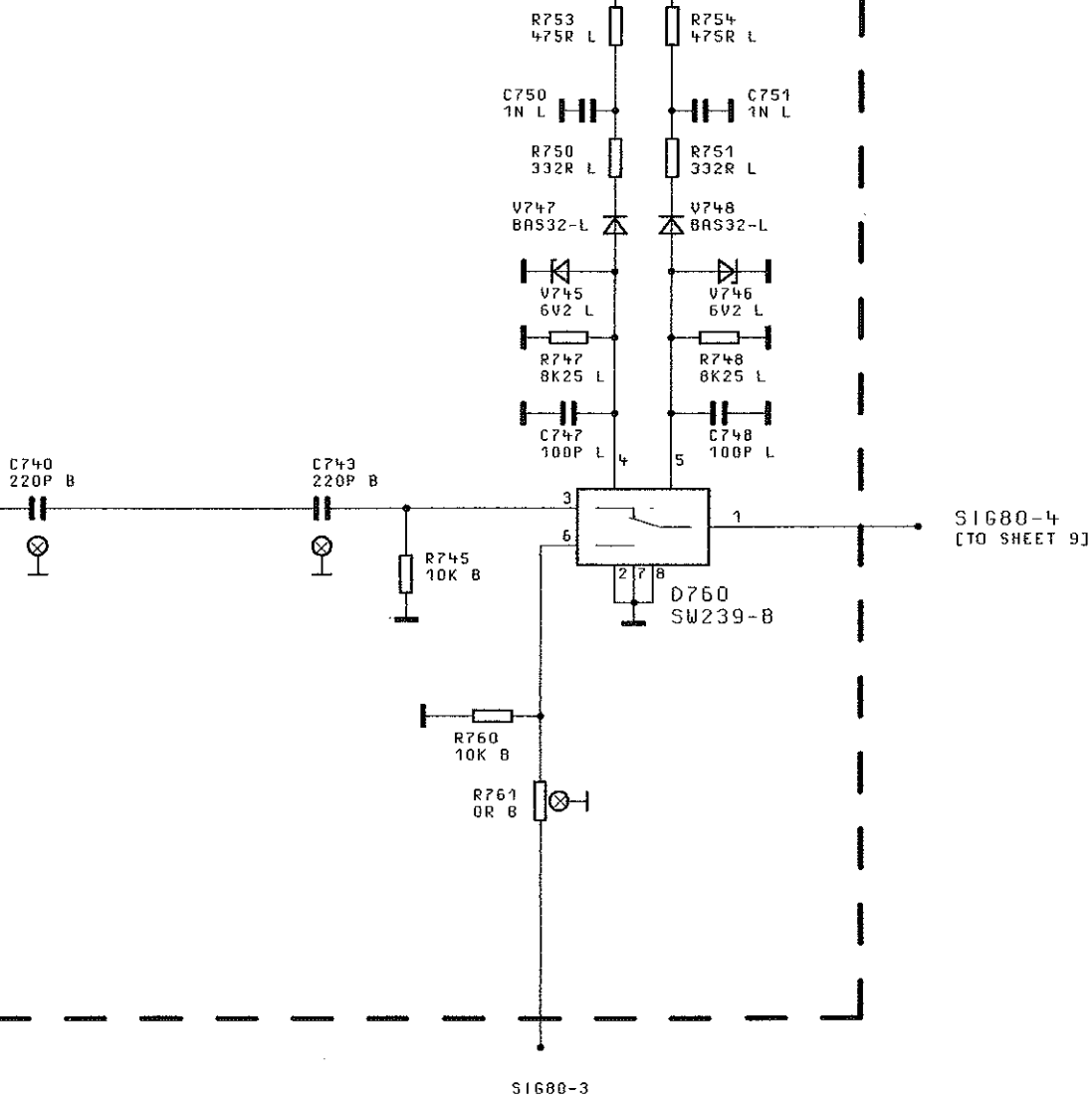

BINDENDE ANGABEN UEBER VARIANTEN,
TRIMMWERTE, BAUTEILWERTE UND
NICHT BESTUECKTE BAUTEILE SIEHE SA.

FOR BINDING INFORMATION ON MODELS,
TRIMMING AND COMPONENTS VALUES AND
NONFITTED COMPONENTS SEE PARTS LIST.

04/01	10.03.97	EI	MENP	TAG	NAME	BENENNUNG AUSGANGSTEIL 1.046GHZ OUTPUT UNIT 1.046GHZ			
			BEARB.		EI				
			GEPR.						
			NORM	14.03.97					
04/	11.07.96	DR	 ROHDE & SCHWARZ			ZEICHN.-NR. 1062.6209.015			
REND. IND.	DATUM	NAME				ZU GERÄT	SMY	REG. I. V.	1062.5502

SWITCH B

H

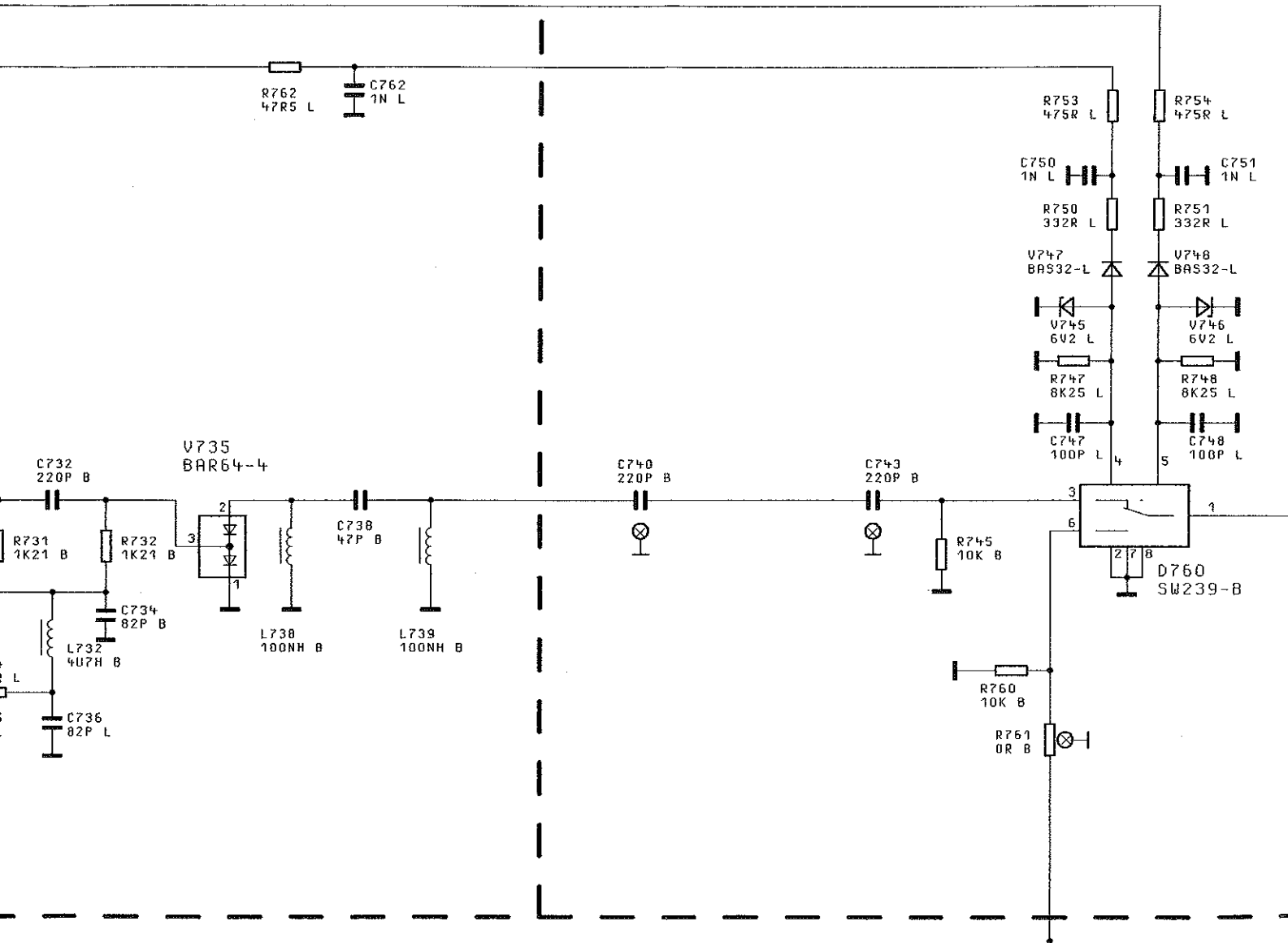

51680-3

N.F. - NOT FITTED / NICHT BESTUECKT

BINDENDE ANGABEN UEBER VARIANTEN,
TRIMMWERTE, BAUTEILWERTE UND
NICHT BESTUECKTE BAUTEILE SIEHE SA.

FOR BINDING INFORMATION
TRIMMING AND COMPONENTS
NONFITTED COMPONENTS SEE



ACHTUNG: EGB!
ELEKTROSTATISCH GEFAHRDETE
BAUELEMENTE ERFORDERN EINE
BESONDERE HANDHABUNG.

ATTENTION ESD!
ELECTROSTATIC SENSITIVE DEVICES
REQUIRE A SPECIAL HANDLING

04/01	10.03.97	E I	MENP	TAG	NAME	BENENNUNG
			BEARB.		E I	
			GEPR.			
			NDRH			
			PLOTT	14.03.97		
04/	11.07.96	DR	 ROHDE & SCHWARZ		ZEICHEN	
REND. IND.	DATUM	NAME			ZU GERÄT	SMY

SWITCH B

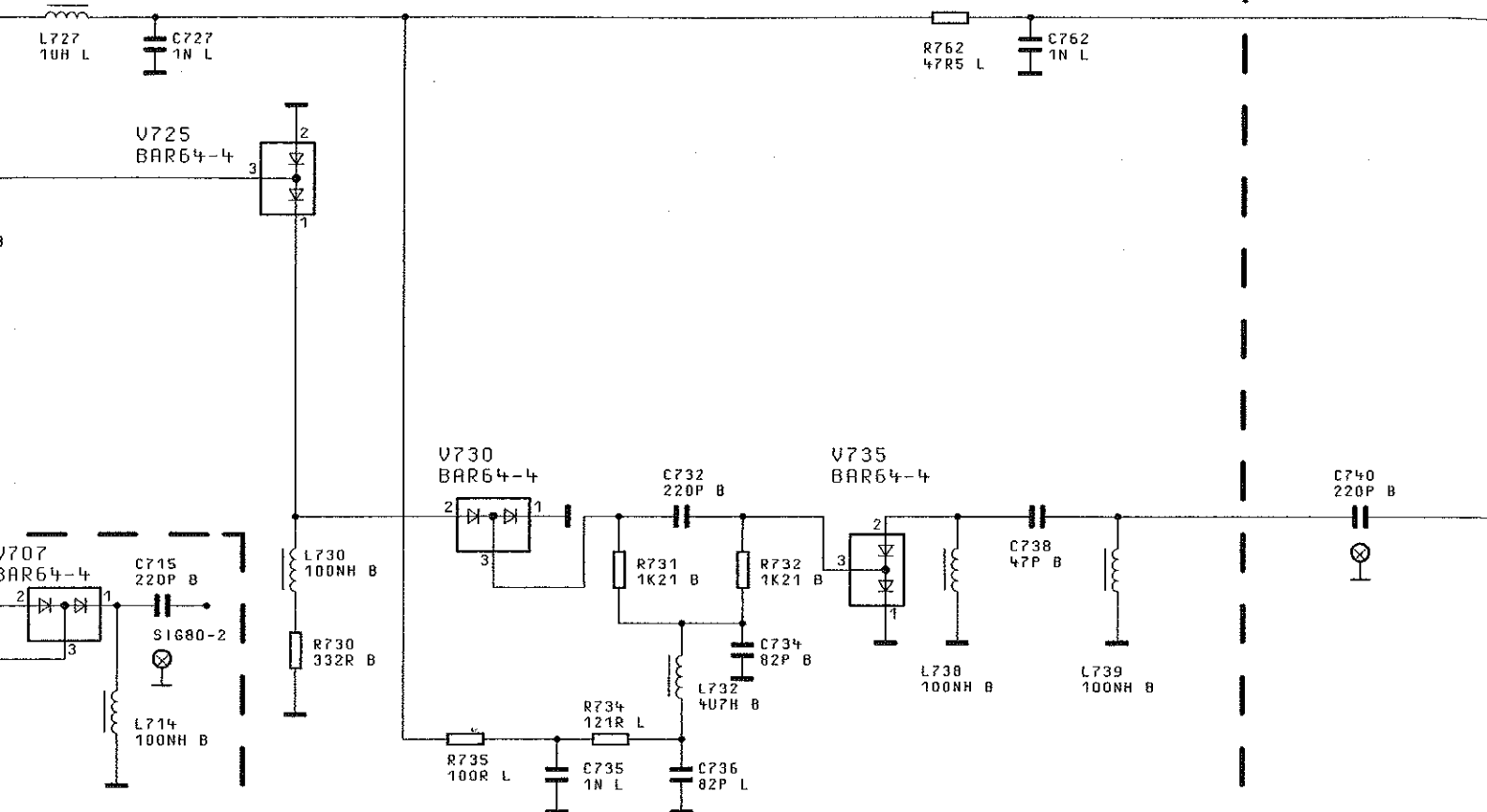

N.F. - NOT FITTED / NICHT BESTUECKT

BINDENDE ANGABEN
TRIMMWERTE,
NICHT BESTUECKT

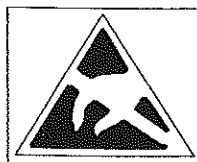

ACHTUNG: EGB!
ELEKTROSTATISCH GEFÄHRDETE
BAUELEMENTE ERFORDERN EINE
BESONDERE HANDHABUNG.
ATTENTION ESD!
ELECTROSTATIC SENSITIVE DEVICES
REQUIRE A SPECIAL HANDLING

04/01	
04/	REND
IND.	REND
	NETTE

SWITCH D

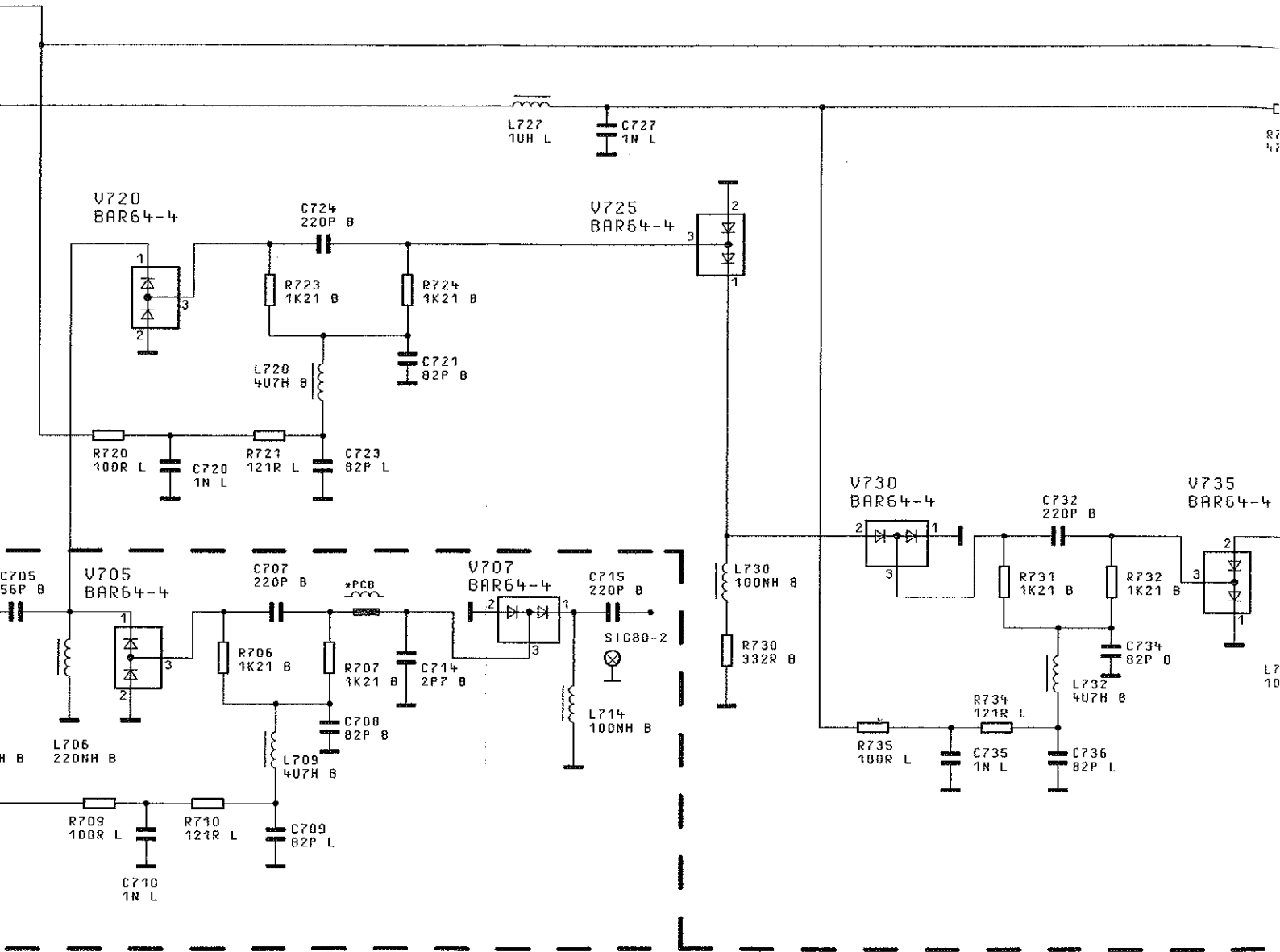

N.F. - NOT

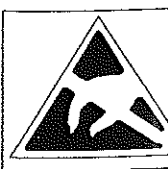

B1 D SWITCH D

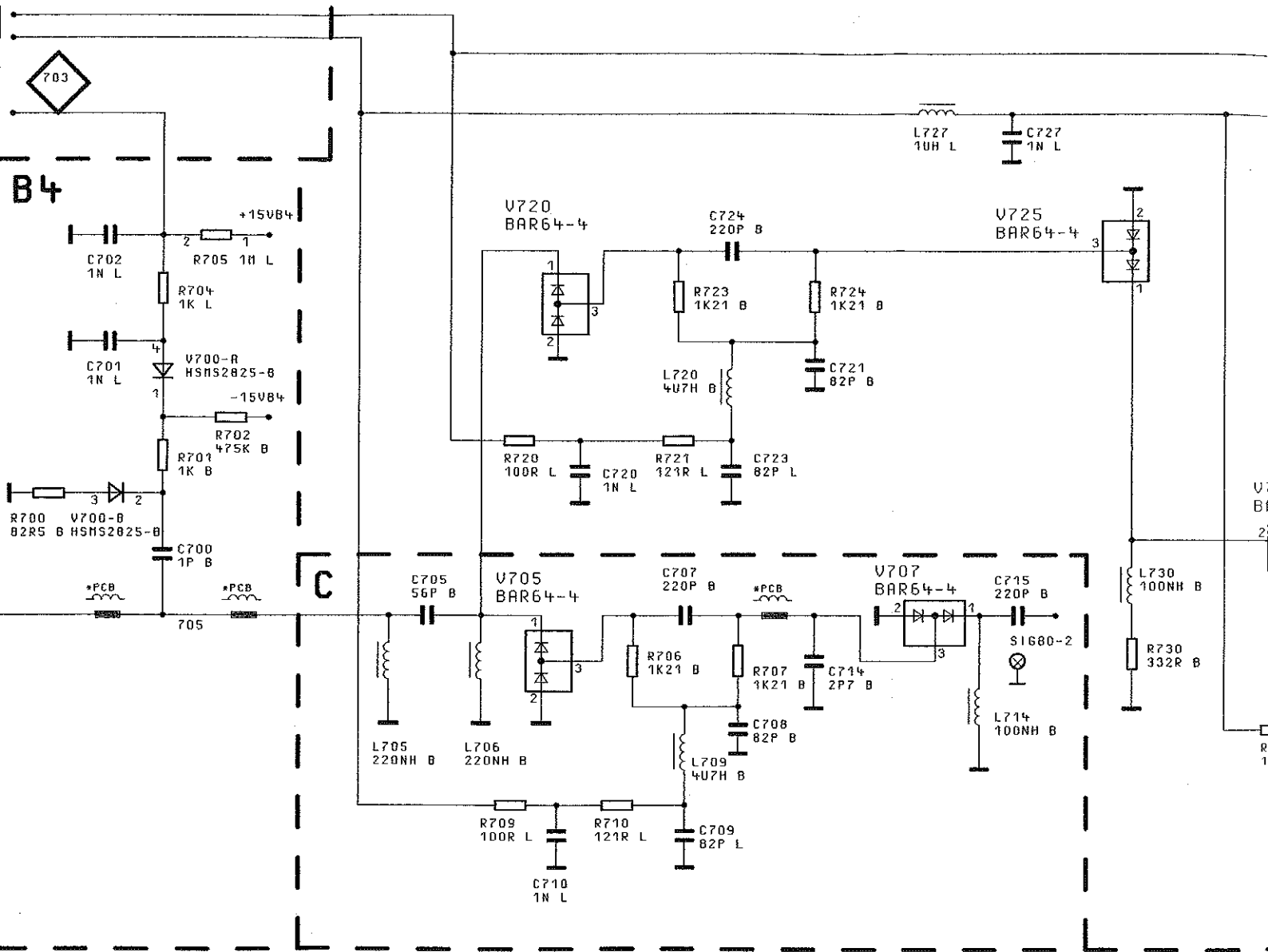

FÜR DIESE UNTERLAGE
BEHALTEN WIR UNS ALLE RECHTE VOR

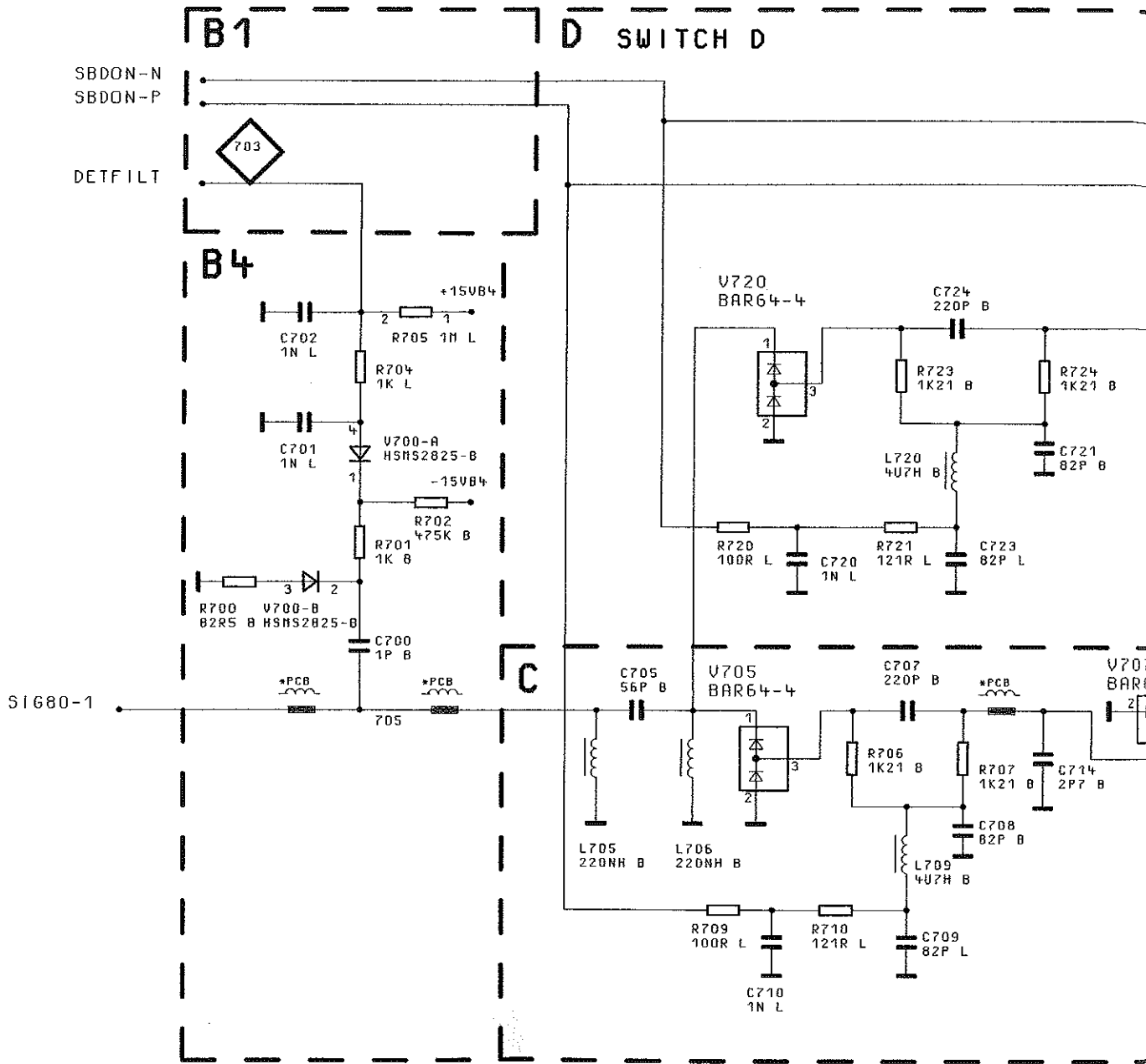

1

2

3

4

FICHEN-NR.



BINDENDE ANGABEN UEBER VARIANTEN,
TRIMMWERTE, BAUTEILWERTE UND
NICHT BESTUECKTE BAUTEILE SIEHE SA.

FOR BINDING INFORMATION ON MODELS,
TRIMMING AND COMPONENTS VALUES AND
NONFITTED COMPONENTS SEE PARTS LIST.

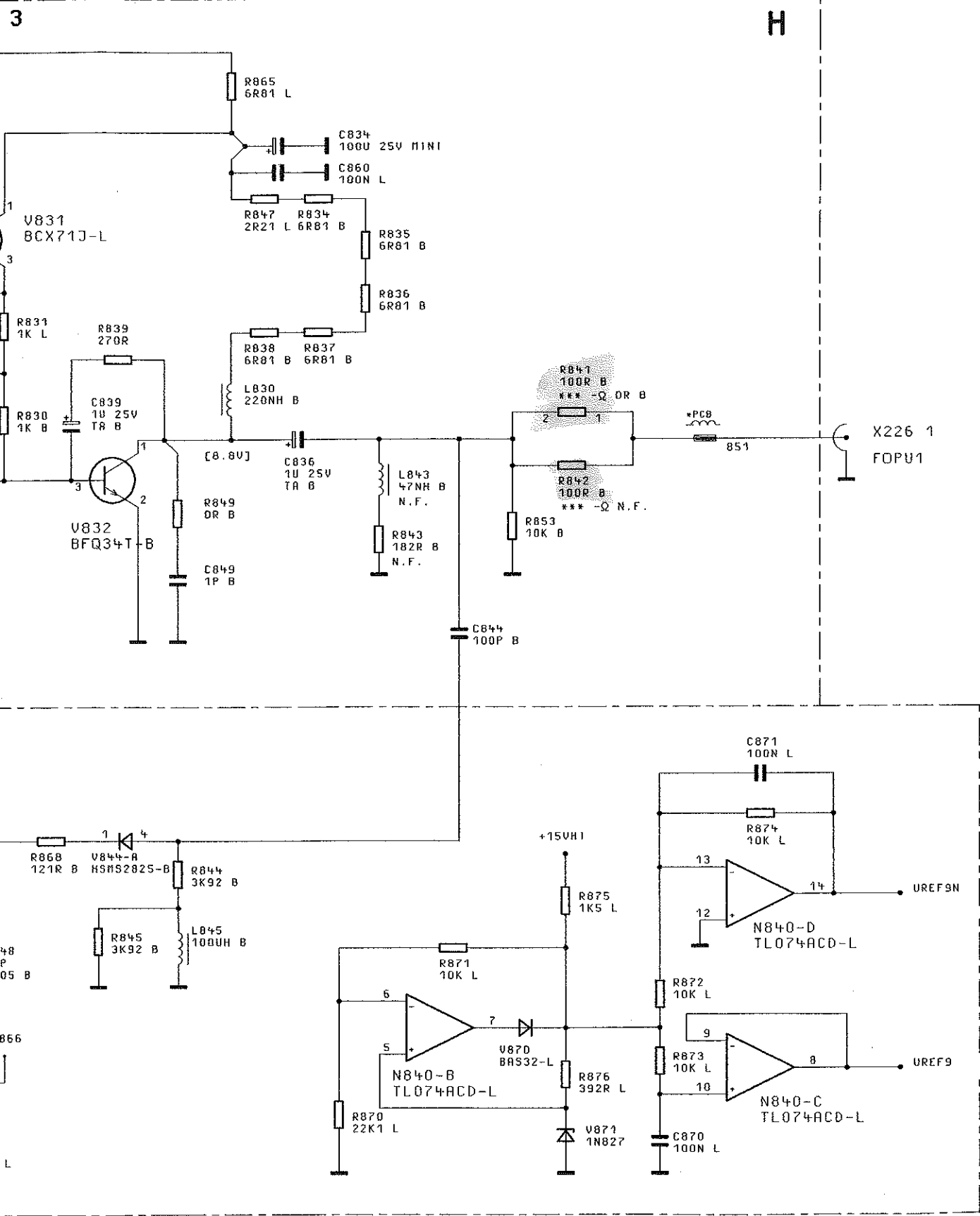

04/01	10.03.97	E I	MENP	TAG	NAME	BENENNUNG	
			BEARB.		E I	AUSGANGSTEIL 1.0466GHZ OUTPUT UNIT 1.0466GHZ	
			GEPR.				
			NORM				
			PLOTT	10.03.97			
04/	11.07.96	DR			ZEICHN.-NR.	1062.6209.015	
REND. IND.	RENDERUNGS- MITTEILUNG	DATUM			NAME		REG. I. V.
			ZU GERÄT	SMY			

BLATT-NR.
9+
v/v BL.

OUTPUT AMPLIFIER 3

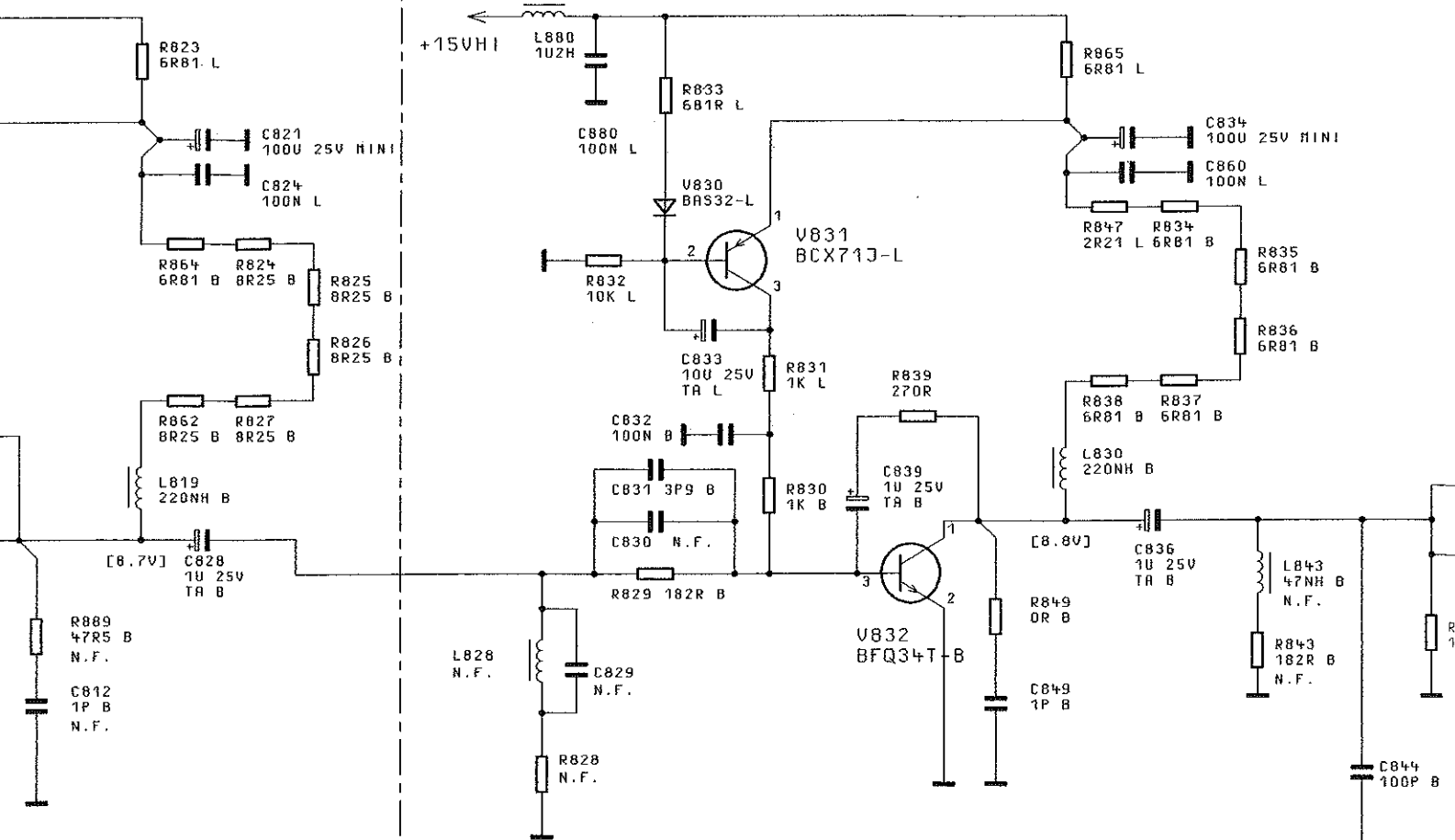

ER

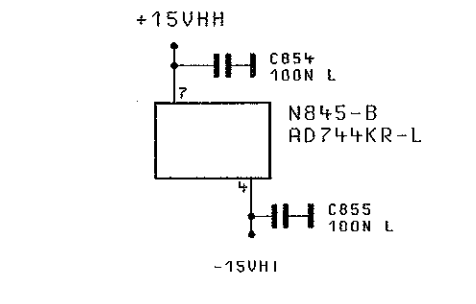
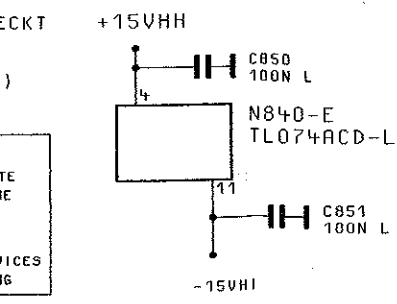
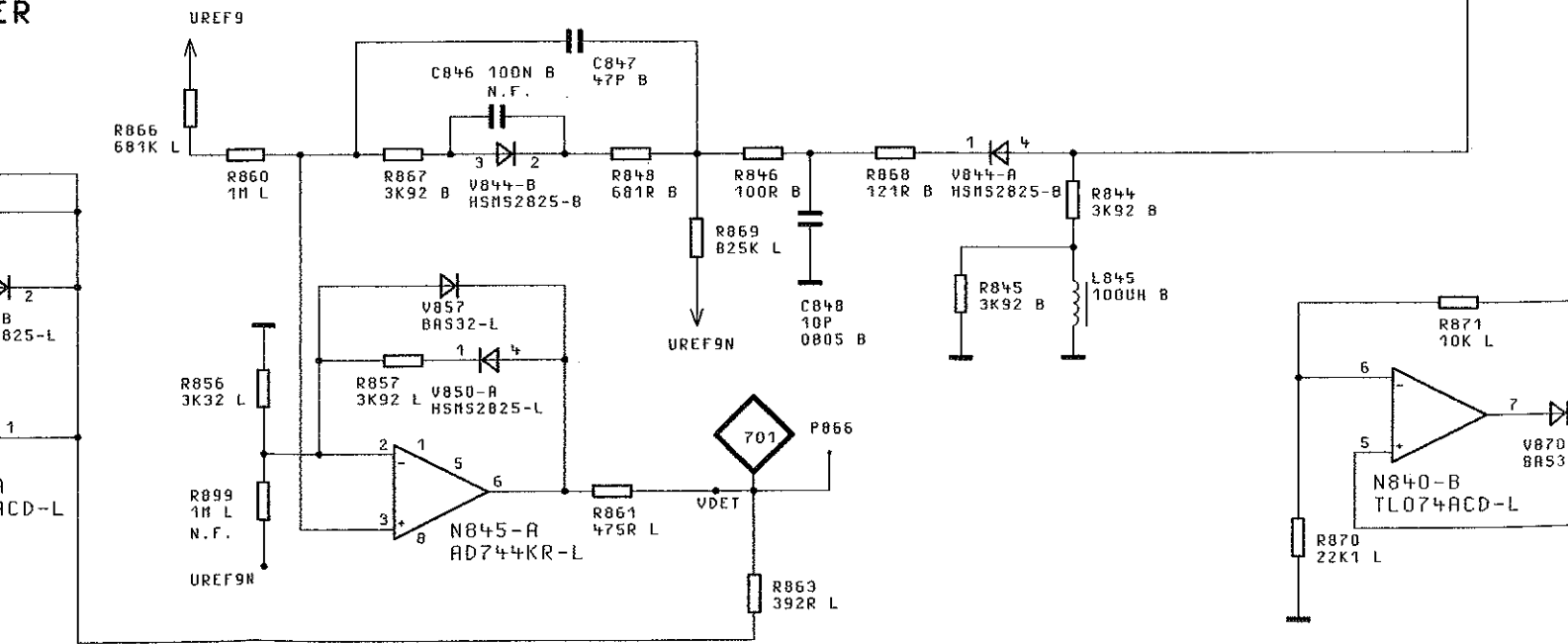

04/01	10.03.97	E1	MENP	TAG	
			BEARB.		
			GEPR.		
			NORM		
			PLOTT	10.03.97	
04/	11.07.96	DR			
REND.	DATUM	NAME			
IND.	RENDERUNGS-NITTEILUNG				
			ZU GERÄT	SNY	

OUTPUT AMPLIFIER 2

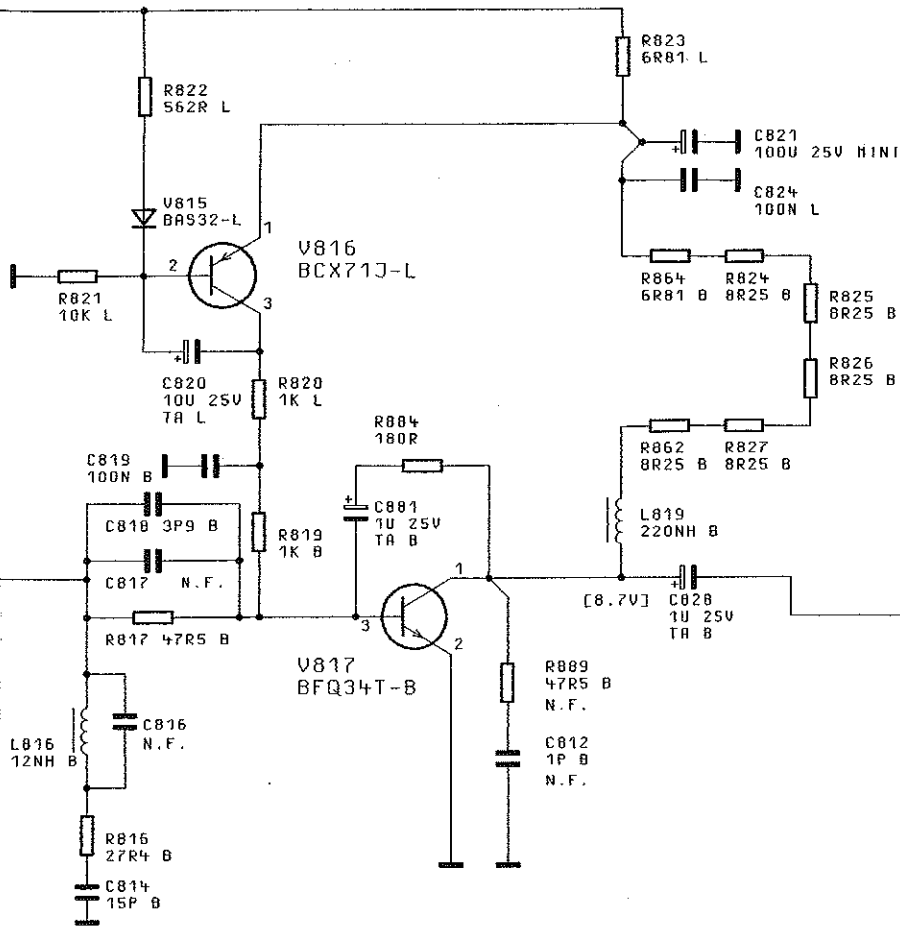

OUTPUT AMPLIFIER 3

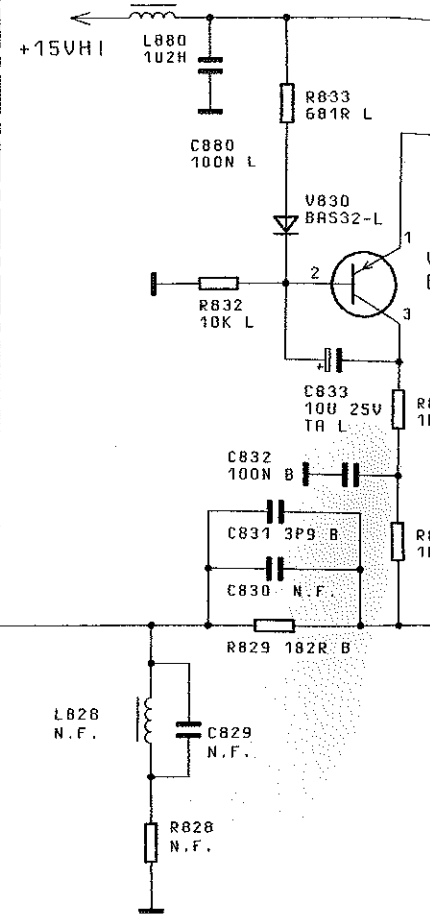

DETECTOR LINEARIZER

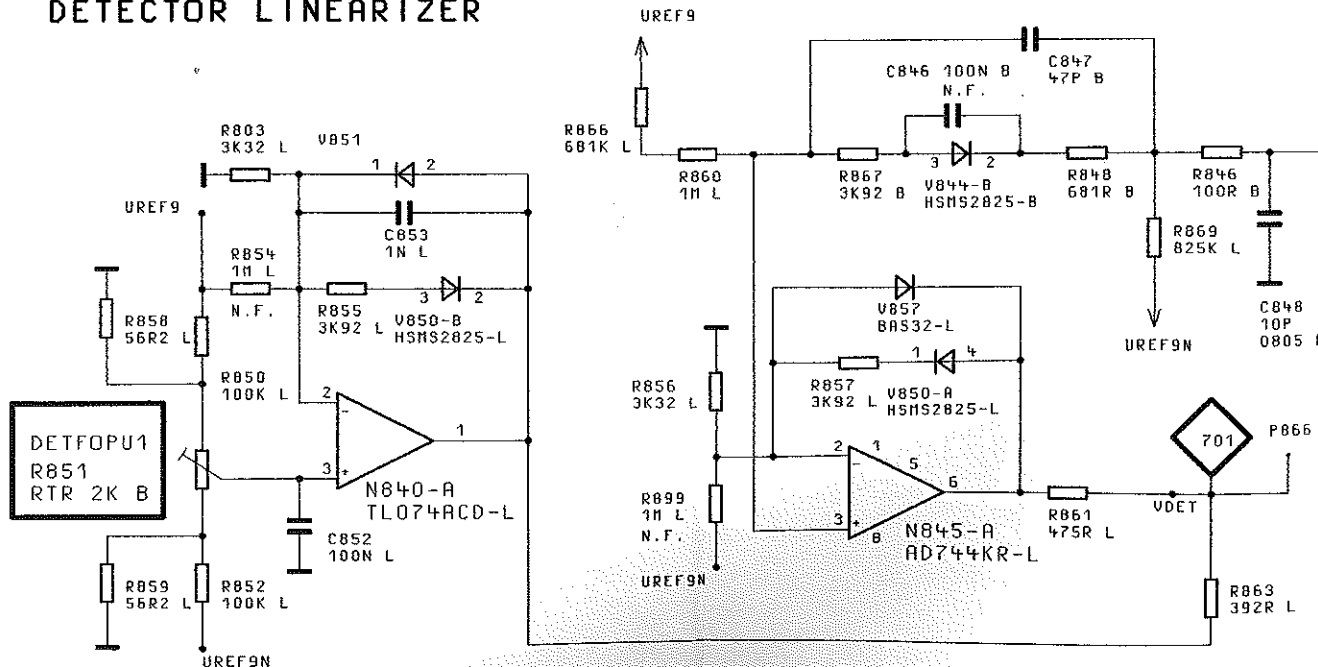

N.F. - NOT FITTED / NICHT BESTUECKT

*** = VAR.06/MOD.06
(MIT/WITH OPTION SMY-B40)

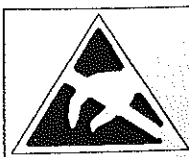

ACHTUNG: ESD!
ELEKTROSTATISCH GEFÄHRDETE
BAUELEMENTE ERFORDERN EINE
BESONDERE HANDHABUNG.
ATTENTION ESD!
ELECTROSTATIC SENSITIVE DEVICES
REQUIRE A SPECIAL HANDLING

+15VHH

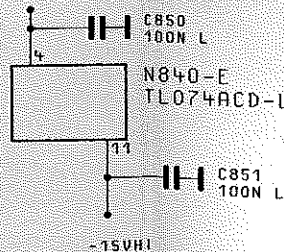

+15VHH

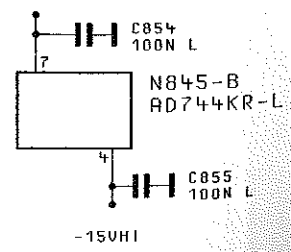

AMPLIFIER 1

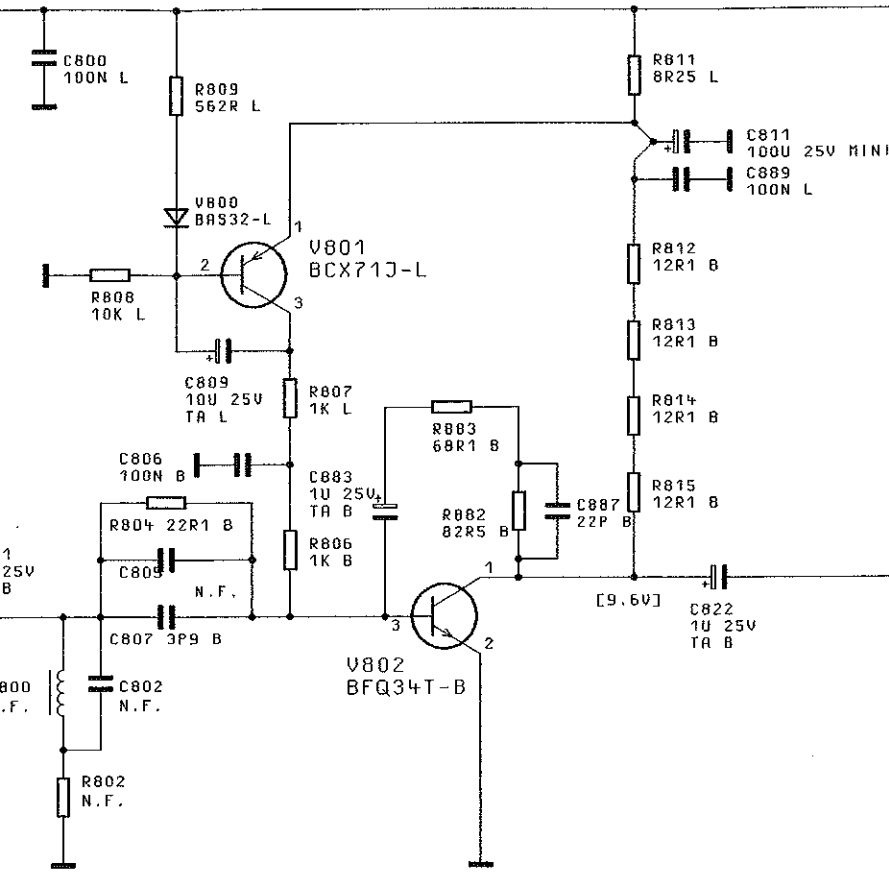

OUTPUT AMPLIFIER 2

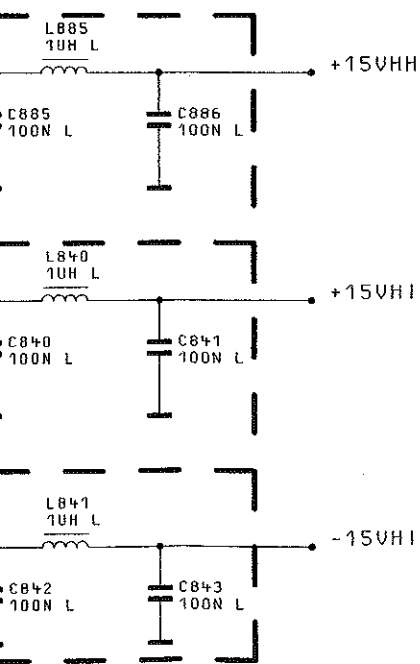
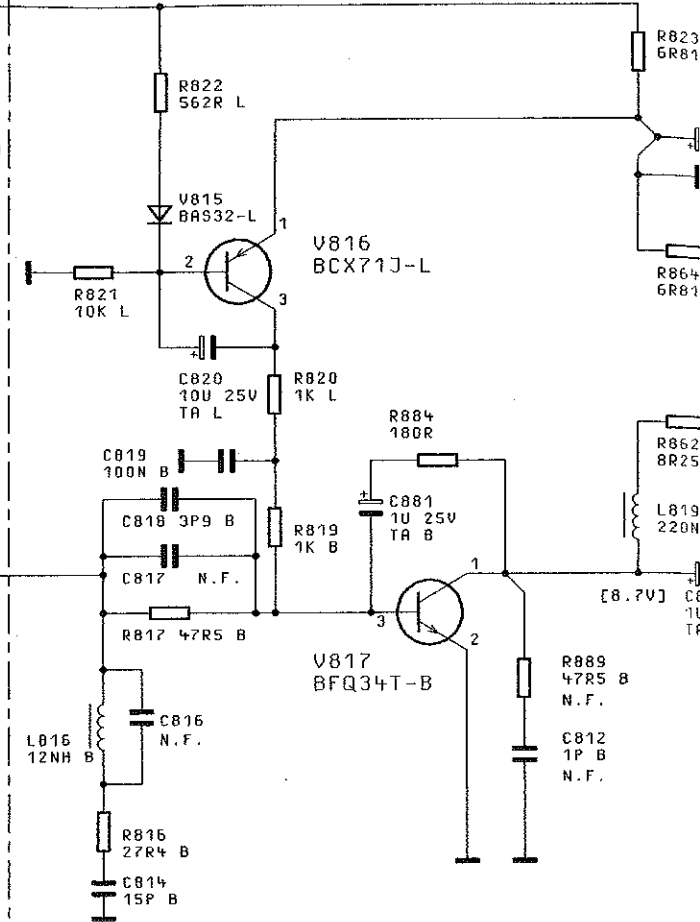

DETECTOR LINEARIZER

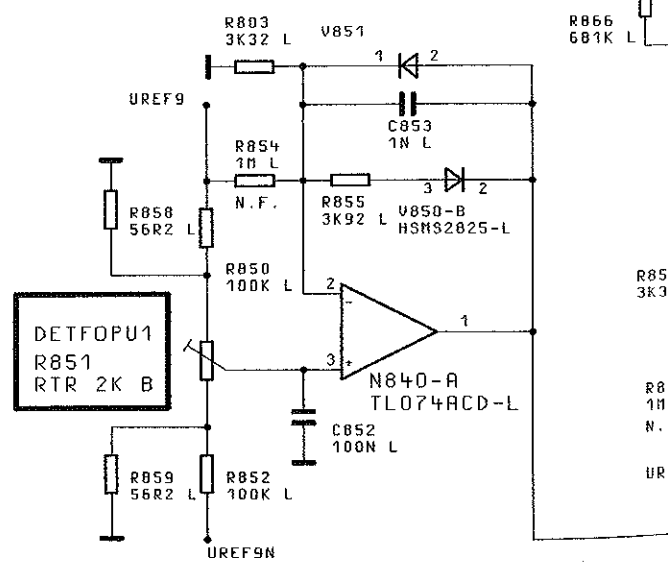

N.F. - NOT FITTED / NICHT BESTUECKT +15VHH
 *** = VAR.06/MOD.06
 (MIT/WITH OPTION SHY-B40)



ACHTUNG: EGB!
 ELEKTROSTATISCH GEFÄHRDETE
 BAUELEMENTE ERFORDERN EINE
 BESONDERE HANDHABUNG.
 ATTENTION ESD!
 ELECTROSTATIC SENSITIVE DEVICES
 REQUIRE A SPECIAL HANDLING

OUTPUT AMPLIFIER 1

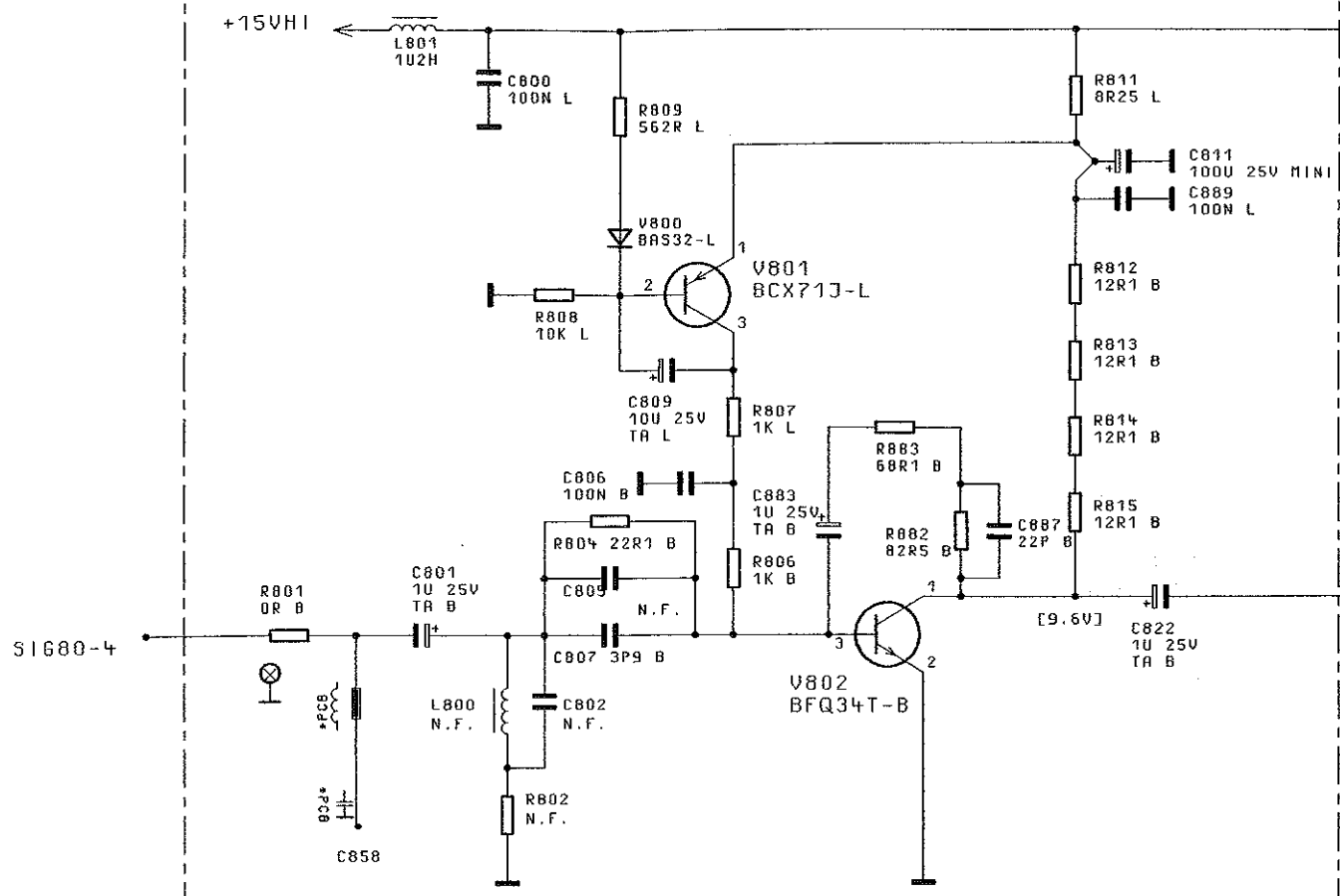

B1

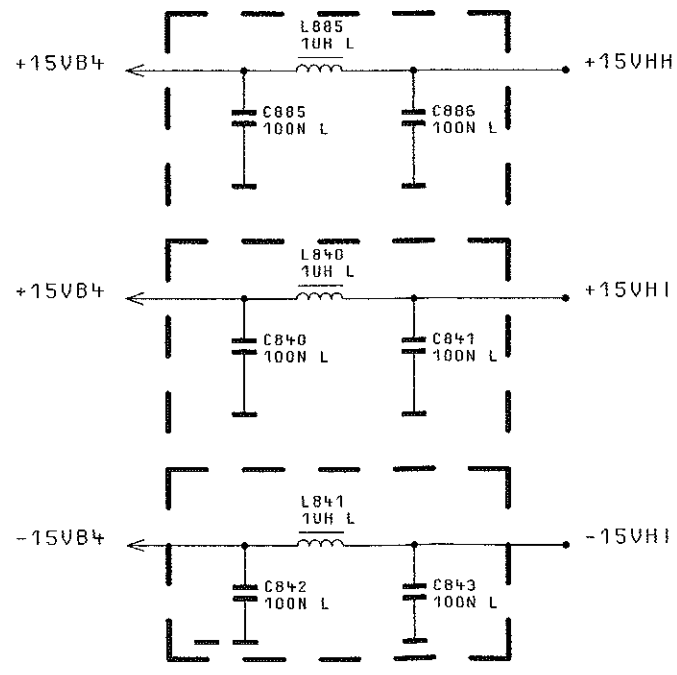

FUER DIESE UNTERLAGE BEHALTEN WIR UNS ALLE RECHTE VOR

ZEICHN.-NR.

BYTE 4+5

BYTE 6+7

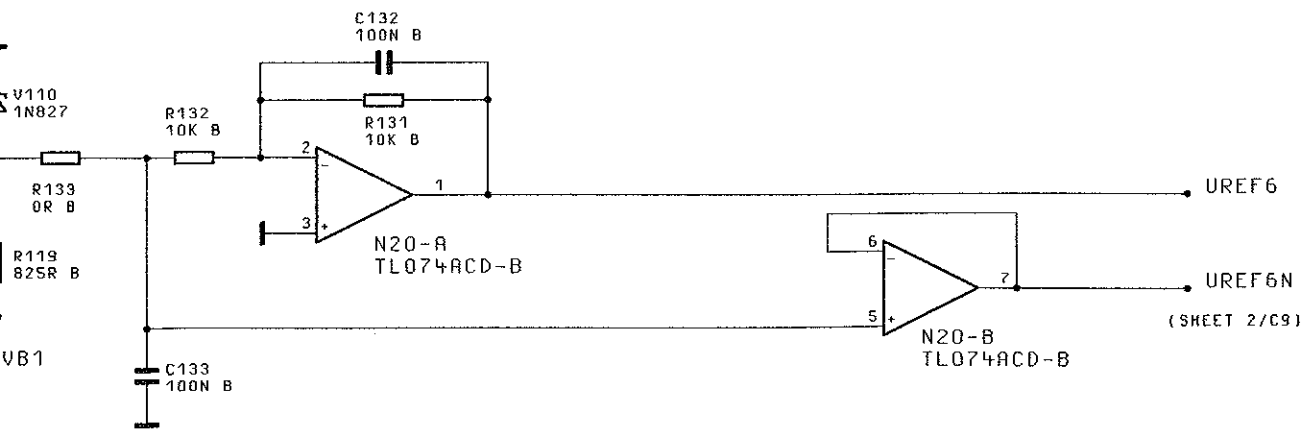
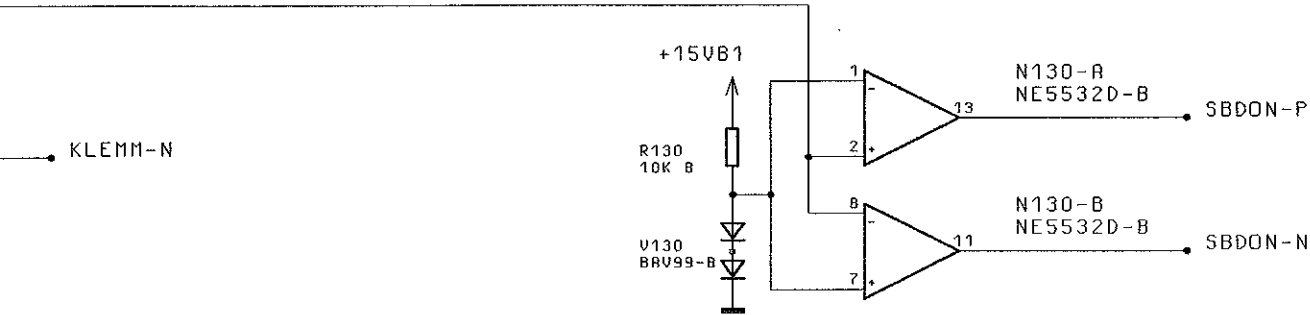
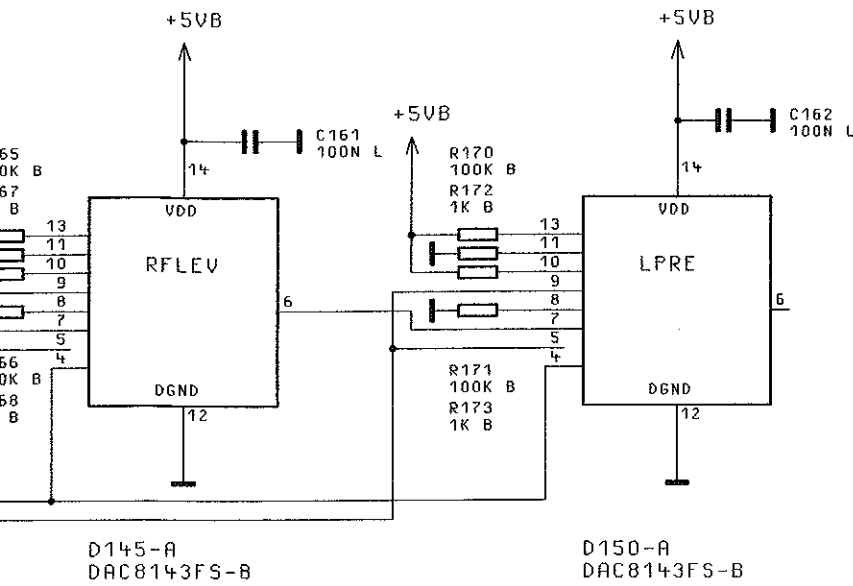

04/01	10.03.97	EI	MENP	TAG	NAME	BENENNUNG	
			BEARB.		EI	AUSGANGSTEIL 1.046GHZ	
			GEPR.			OUTPUT UNIT 1.046GHZ	
			NORM				
			PLOTT	10.03.97			
04/	11.07.96	DR			ZEICHN.-NR.		BLATT-NR.
REND. IND.	ÄNDERUNGS-MITTEILUNG	DATUM			NAMEN	1062.6209.019	
			ROHDE&SCHWARZ		RES. I.V. 1062.5502		ERSTE Z. 1062.5502
			ZU GERÄT	SMY			

BYTE 2+3

BYTE 3+4

BYTE 4+5

BYTE

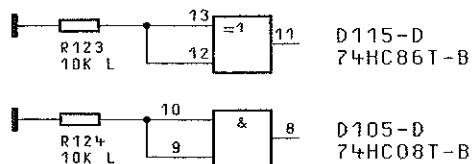
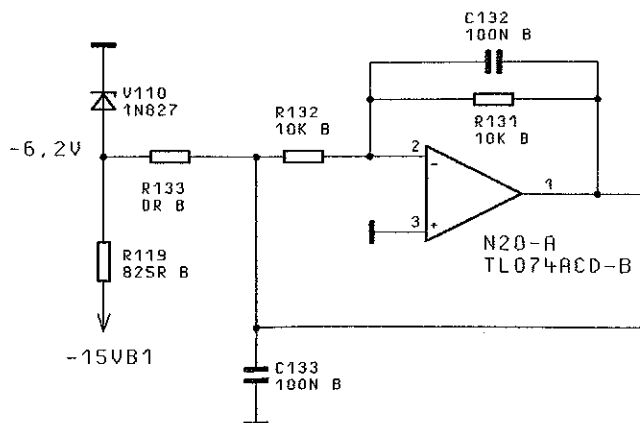
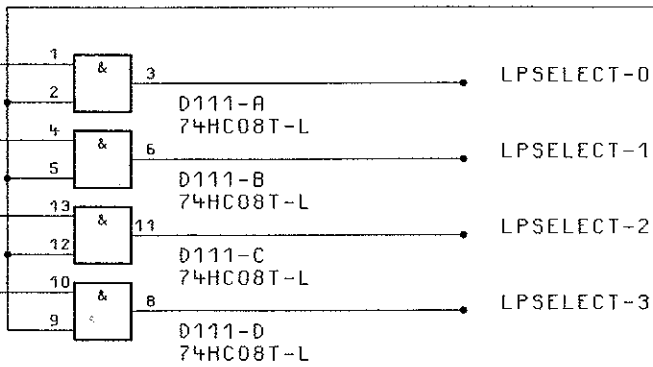
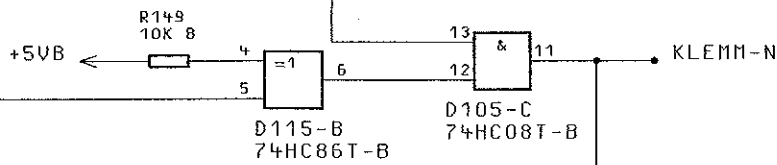
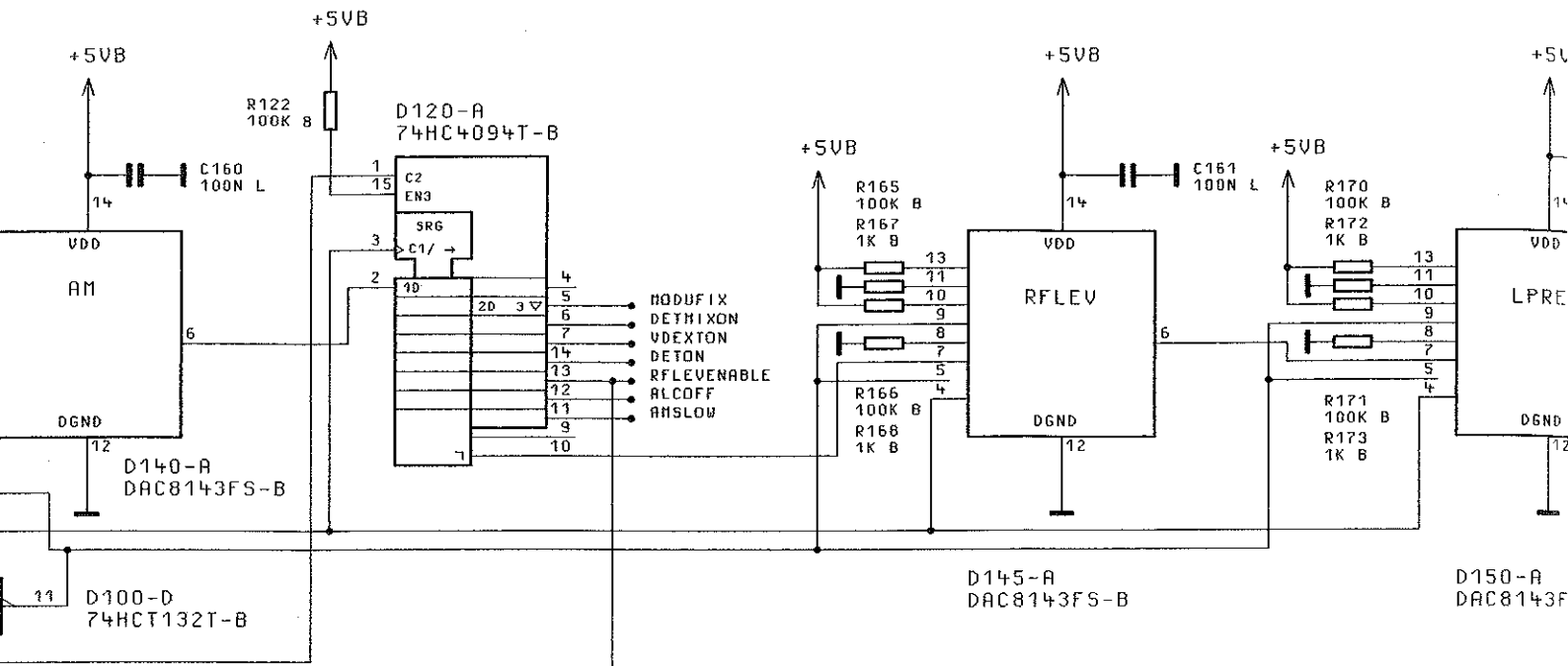

04/01	10.03.97	E I	MENP	TAG
			BEARB.	
			GEPR.	
			NORM	
			PLOTT	10.03.97
04/	11.07.96	DR	 ROHDE & S ZU GERÄT SMY	
REND. IND.	RENDERUNGS- MITTEILUNG	DATUM		

BYTE 1

BYTE 2+3

BYTE 3+4

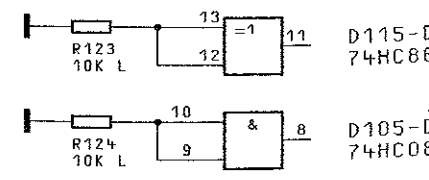
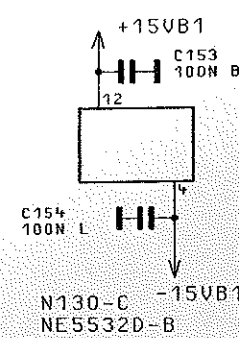
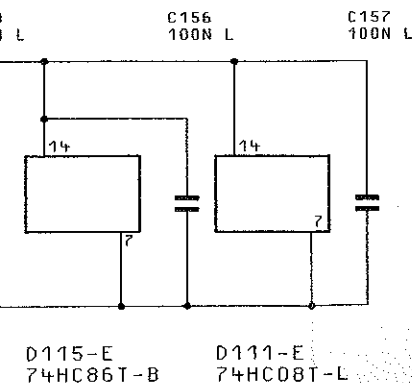
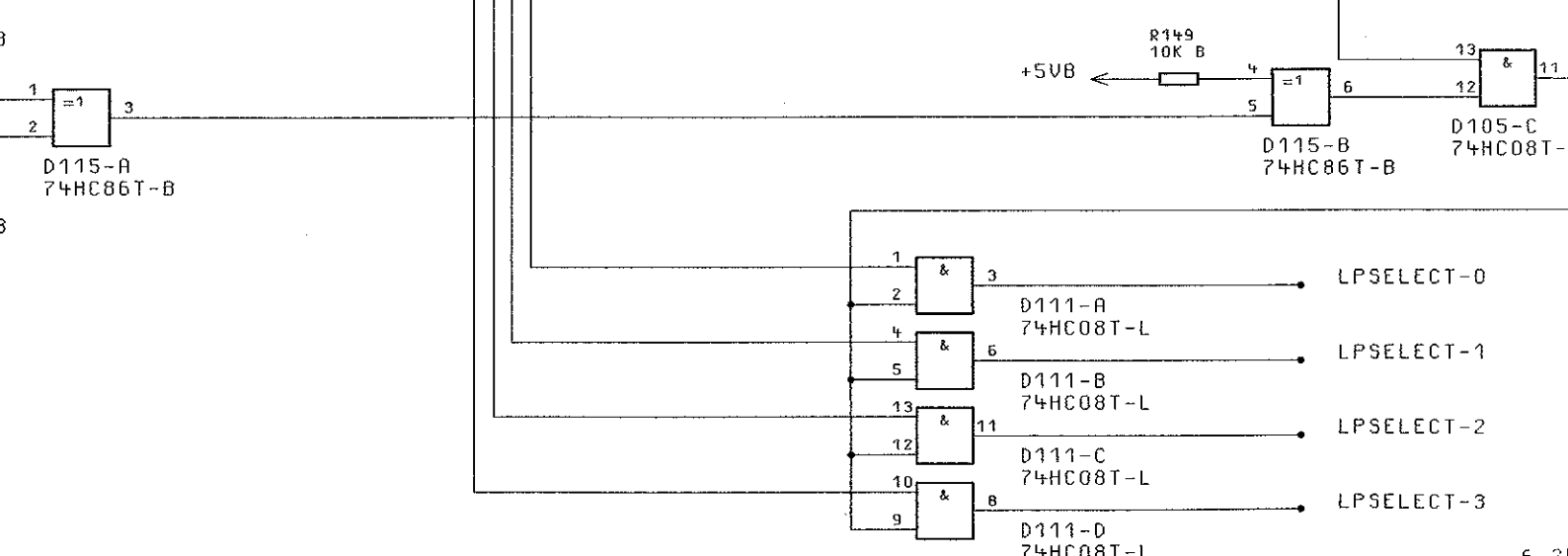
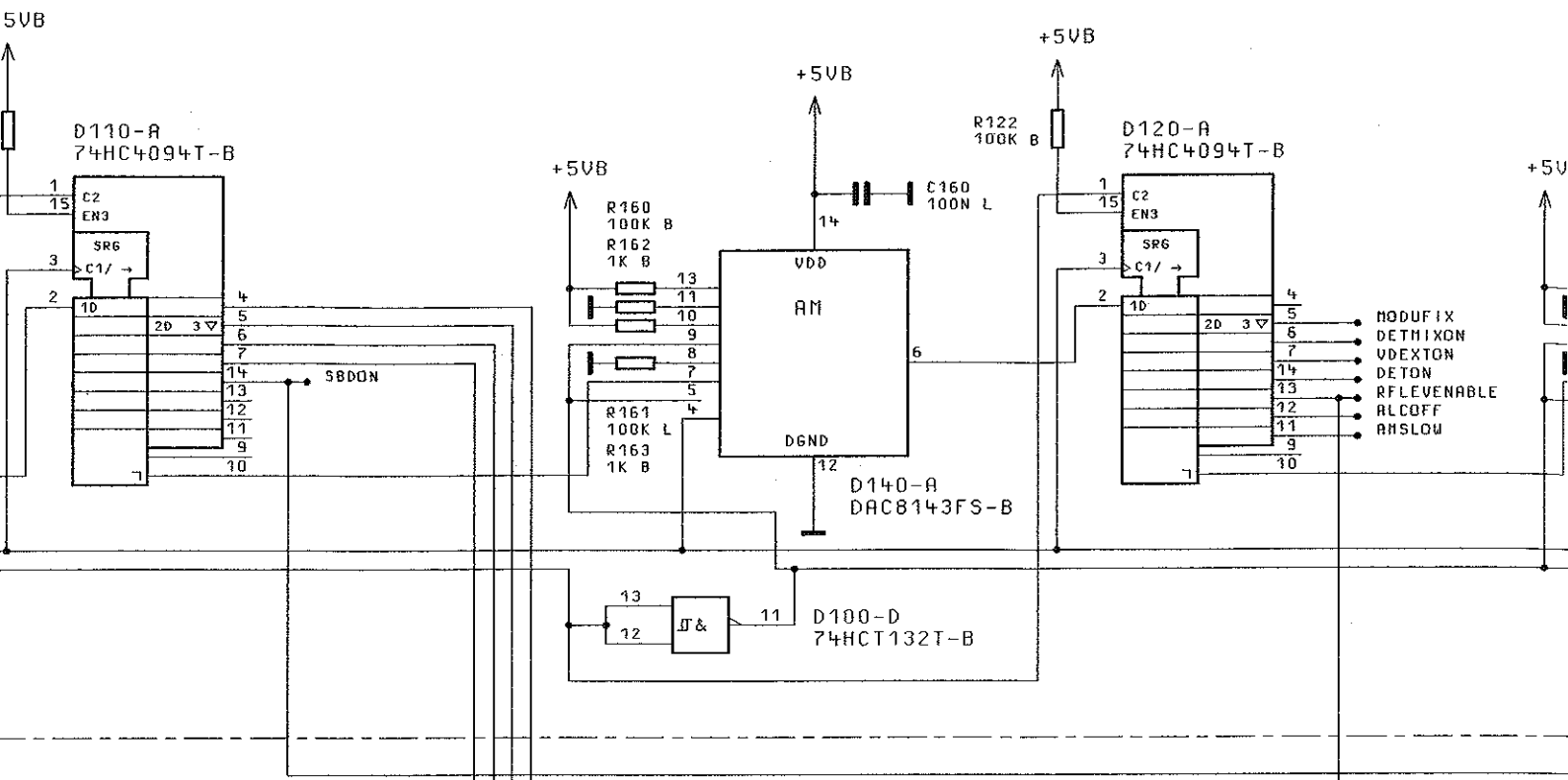

**SUBADDRESS 0
BYTE 0**

BYTE 1

BYTE

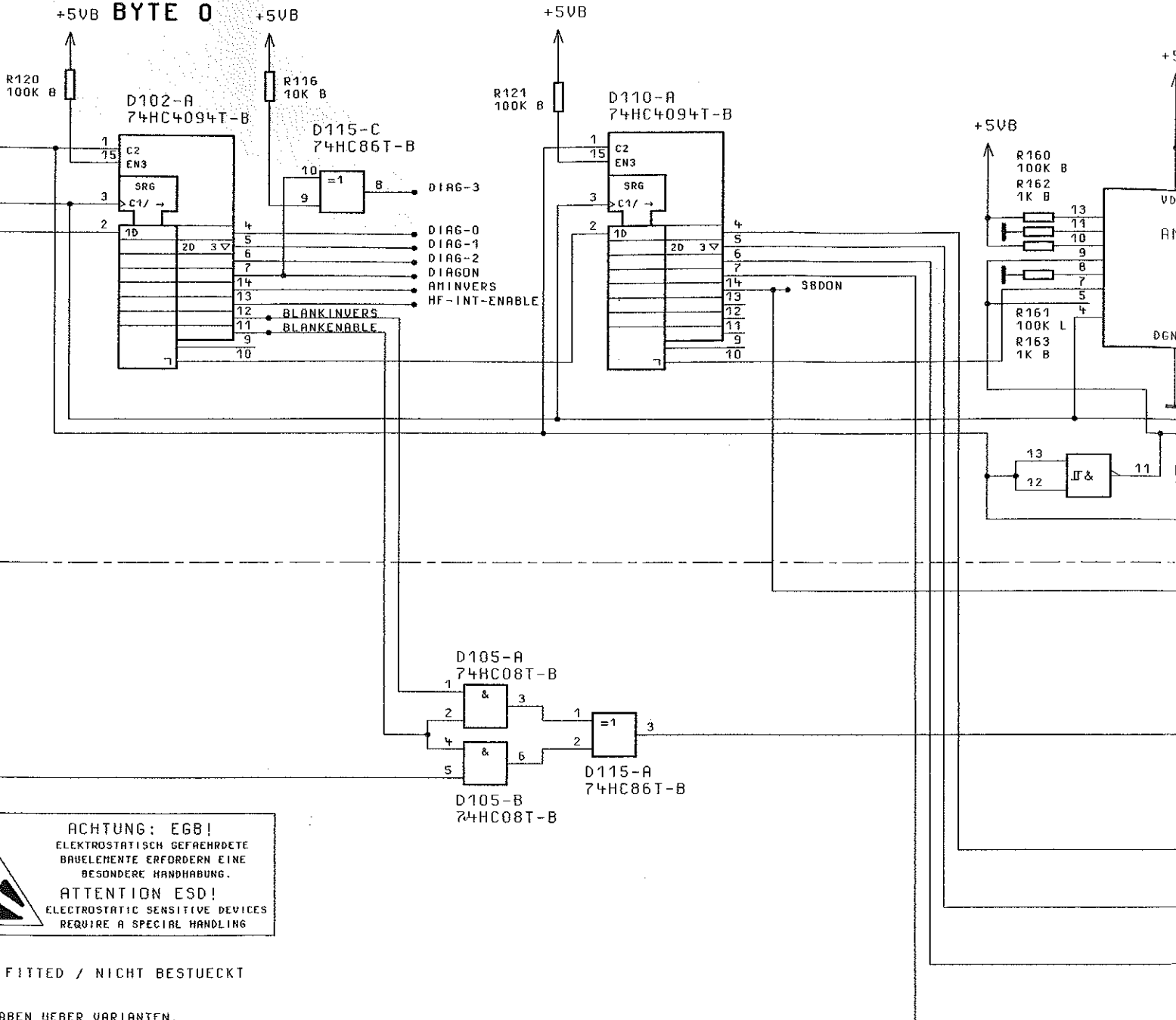

ACHTUNG: EGB!
ELEKTROSTATISCH GEFÄHRDETE
BAUELEMENTE ERFORDERN EINE
BESONDERE HANDHABUNG.
ATTENTION ESD!
ELECTROSTATIC SENSITIVE DEVICES
REQUIRE A SPECIAL HANDLING

NOT FITTED / NICHT BESTUECKT

ANGABEN ÜBER VARIANTEN,
C, BAUTEILWERTE UND
BESTUECKTE BAUTEILE SIEHE SA.

FOR MORE INFORMATION ON MODELS,
PARTS AND COMPONENTS VALUES AND
SPECIFICATIONS SEE PARTS LIST.

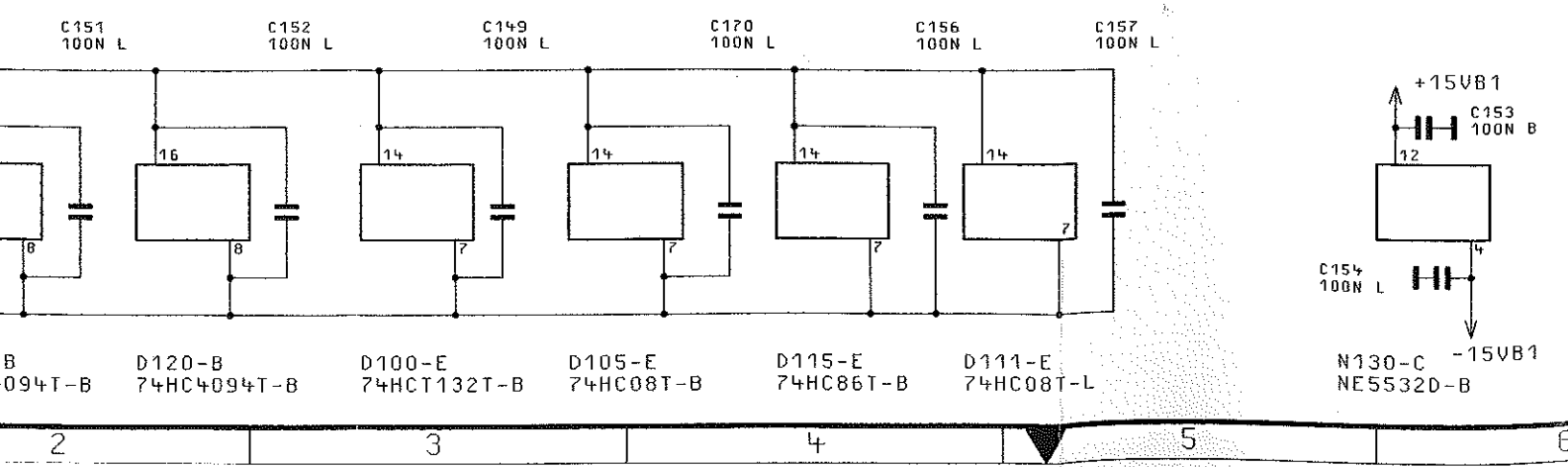

FUER DIESE UNTERLAGE
 BEHALTEN WIR UNS ALLE RECHTE VOR

ZEICHN.-NR.

F

E

D

C

B

A

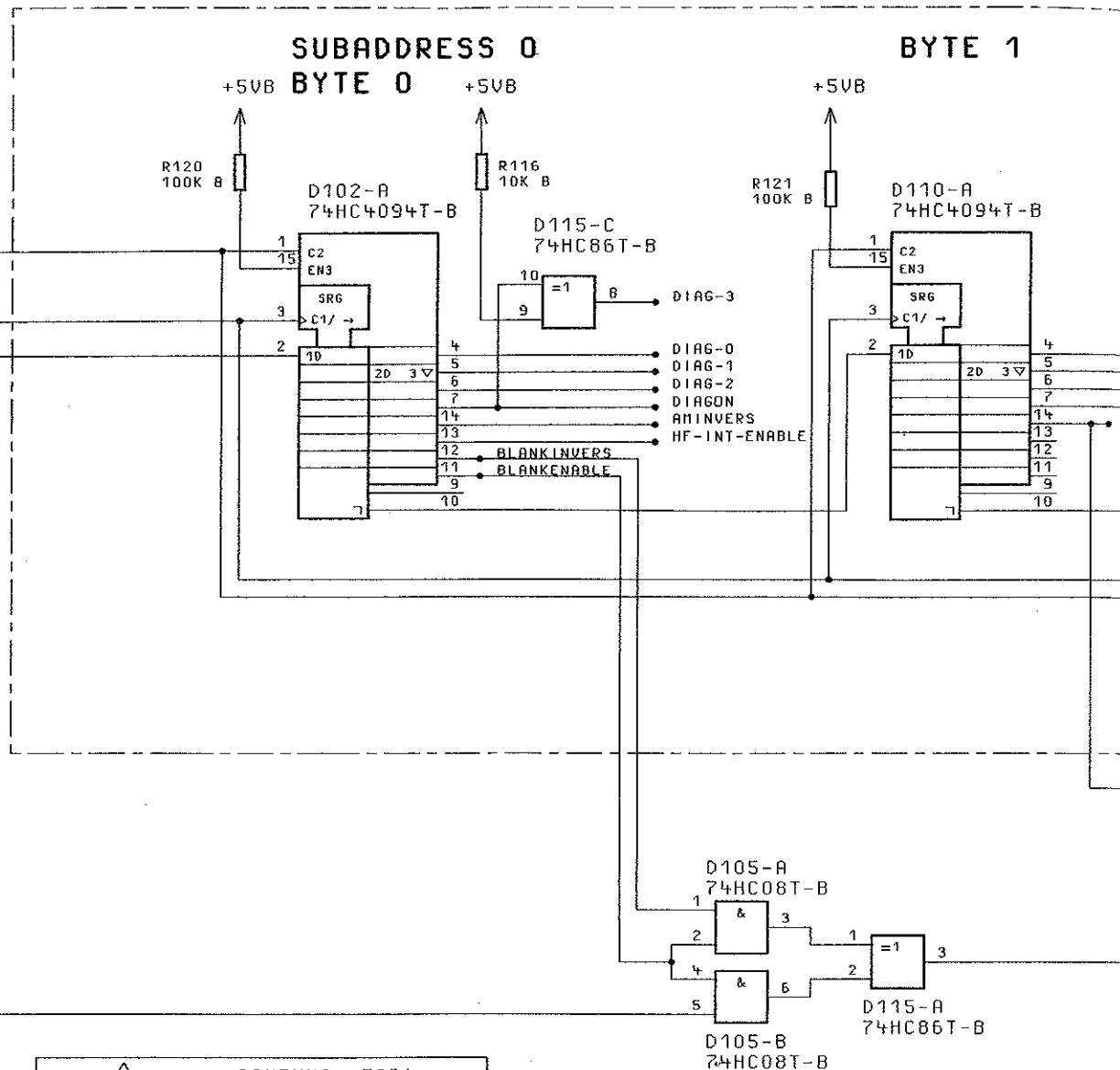



ACHTUNG: EGB!
 ELEKTROSTATISCH GEFÄHRDETE
 BAUELEMENTE ERFORDERN EINE
 BESONDERE HANDHABUNG.
ATTENTION ESD!
 ELECTROSTATIC SENSITIVE DEVICES
 REQUIRE A SPECIAL HANDLING

N.F. = NOT FITTED / NICHT BESTUECKT

BINDENDE ANGABEN UEBER VARIANTEN,
 TRIMMWERTE, BAUTEILWERTE UND
 NICHT BESTUECKTE BAUTEILE SIEHE SA.

FOR BINDING INFORMATION ON MODELS,
 TRIMMING AND COMPONENTS VALUES AND
 NONFITTED COMPONENTS SEE PARTS LIST.

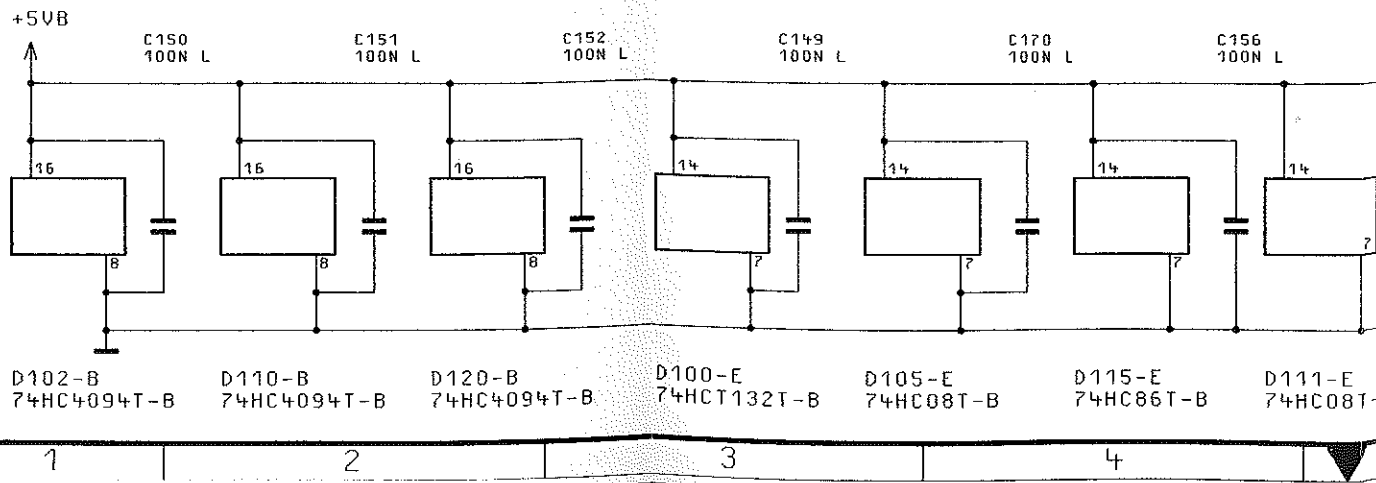

1

2

3

4

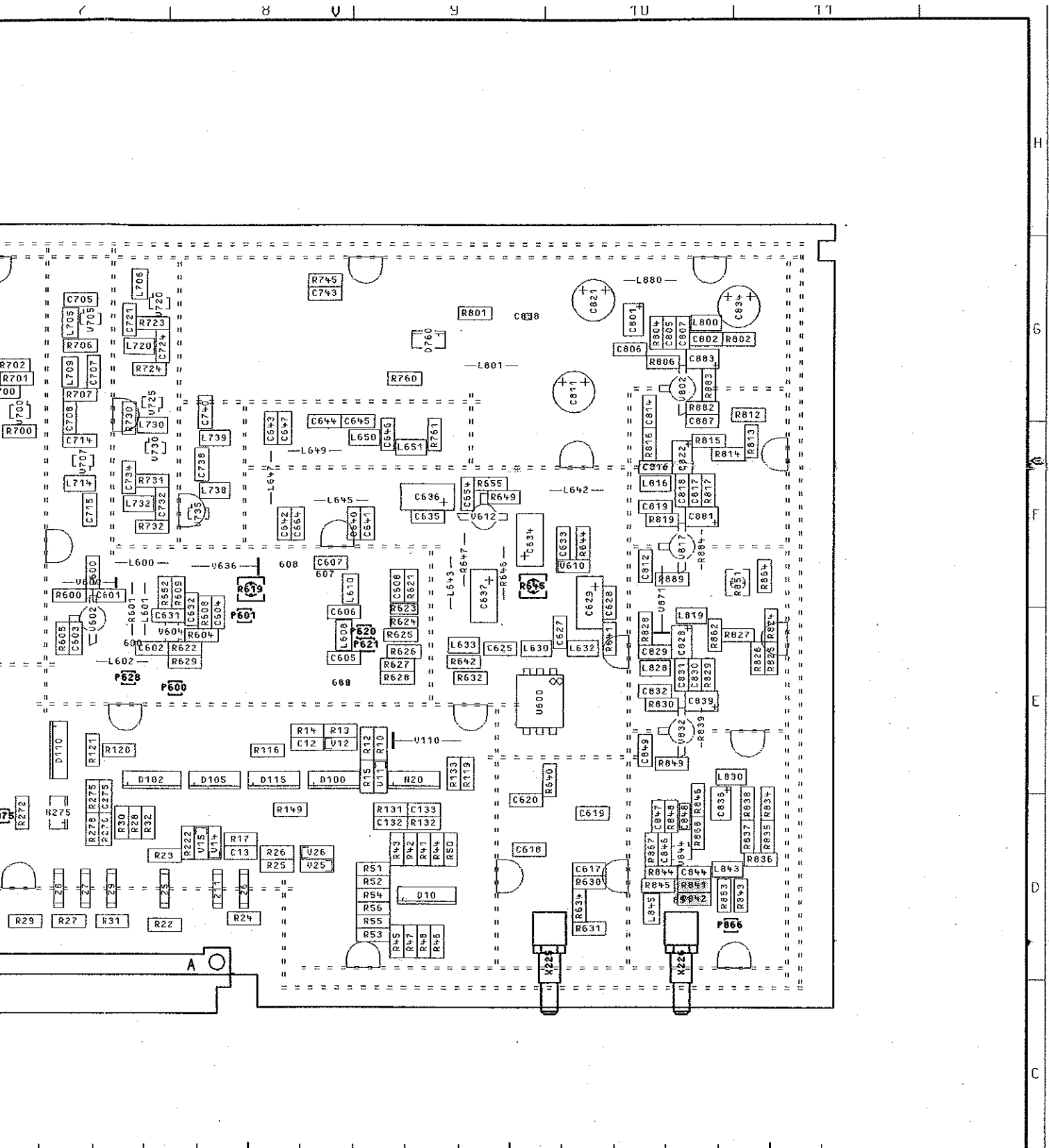

03/		11.07.96	DR	1GPK	TRG	NABE	BENENNUNG		
				BEARB.		DR	AUSGANGSTEIL 1.0466HZ	Z	
				GEPR.			OUTPUT UNIT 1.0466HZ		
				NORM					
				PLOTT	11.07.96				
02/		08.10.93	DR				ZEICHN.-NR.	BAUT.-NR.	
REND. IND.	RENDERUNGS- MITTE FLUNG	DATUM	NABE				1062.6209.01	EE	1+
				ZU GERÄT	STY	PER. I.V.	1062.5502	ERSTE Z.	1062.5502

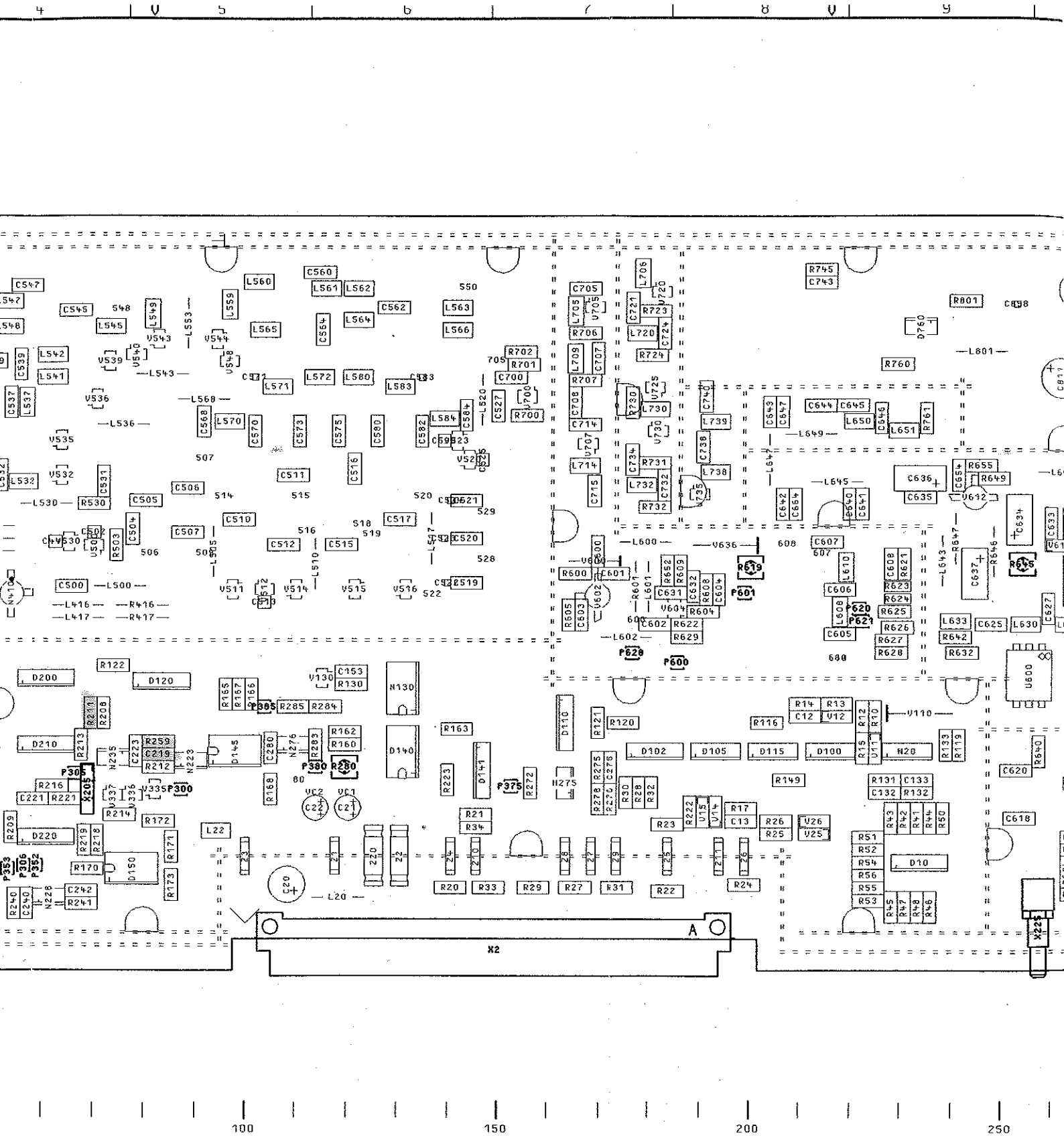

BILDENDE ANGABEN UEBER VARIANTEN,
 TRIMMWERTE, BAUTEILWERTE UND
 NICHT BESTUECKTE BAUTEILE SIEHE SR.

FOR BINDING INFORMATION ON MODELS,
 TRIMMING AND COMPONENTS VALUES AND
 NONFITTED COMPONENTS SEE PARTS LIST.

03/		11.07.96	DR	16PK
				BEARB.
				GEPR.
				NORM
				PLOTT
02/		08.10.93	DR	ROH
REND.	RENDERUNGS-	DATUM	NAM	ZU GEBAU
INH.	MITTEILUNG			

150
100
50
0

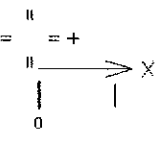
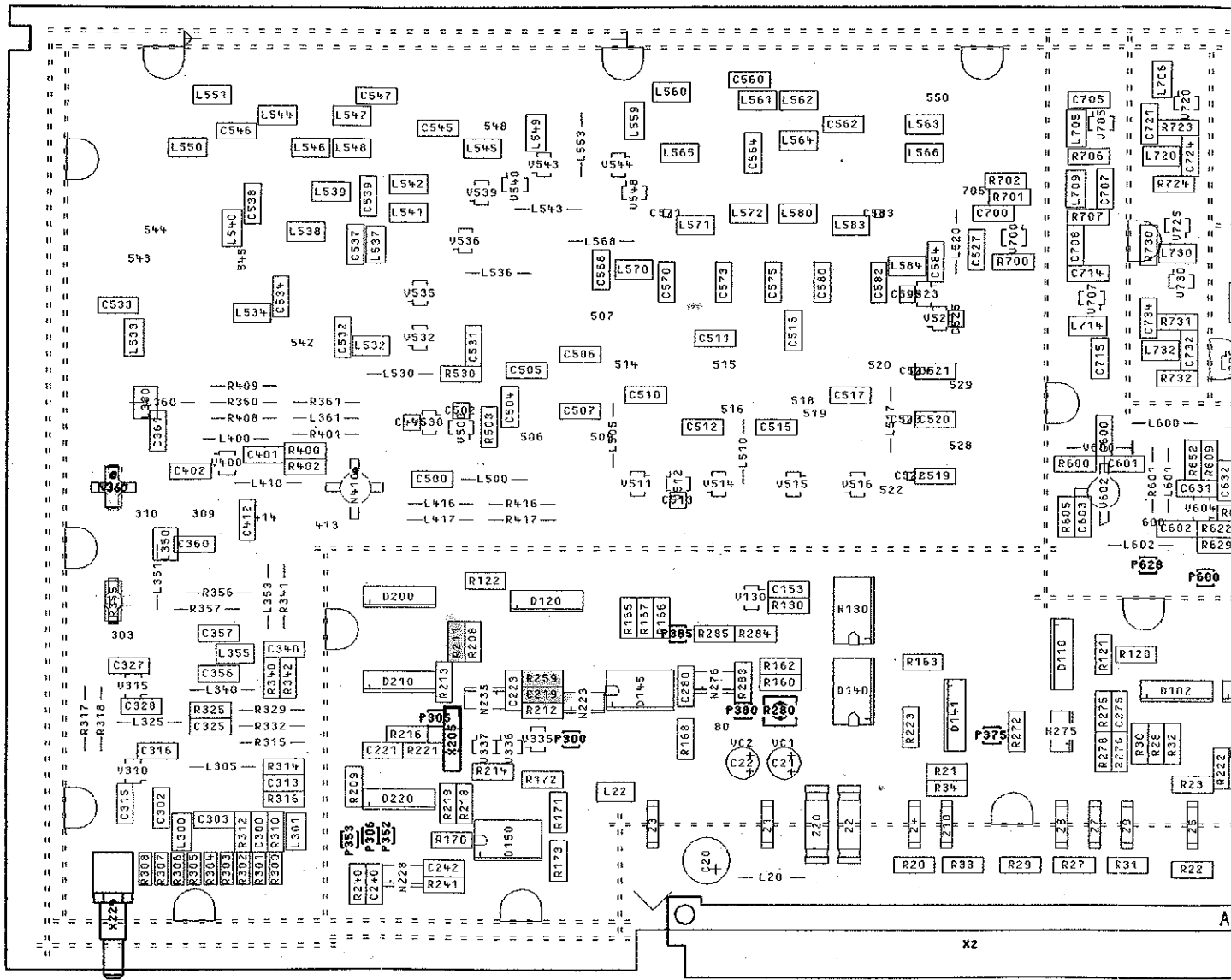

SEITE B
B



ACHTUNG: EGB!
ELEKTROSTATISCH GEFÄHRDUNG
BAUELEMENTE Erfordern eine
Besondere Handhabung.
ATTENTION ESD!
ELECTROSTATIC SENSITIVE DEVICES
REQUIRE A SPECIAL HANDLING

BINDENDE ANGABEN UEBER VARIANTEN,
TRIMMWERTE, BAUTEILWERTE UND
NICHT BESTUECKTE BAUTEILE SIENDE SA.

FOR BINDING INFORMATION ON MODELS,
TRIMMING AND COMPONENTS VALUES AND
NON-FITTED COMPONENTS SEE PARTS LIST.

**DARSTELLUNG SEITE B
VIEW ON SIDE B**



ACHTUNG: ESB!
ELEKTROSTATISCH GEFÄHRDETE
BAUELEMENTE ERFORDERN EINE
BESONDERE HANDHABUNG.
ATTENTION ESD!
ELECTROSTATIC SENSITIVE DEVICES
REQUIRE A SPECIAL HANDLING.

BINDENDE ANGABEN UEBER VARIANTEN,
TRIMMWERTE, BRUETIELWERTE UND
NICHT BESTUECKTE BRUETELLE SIEHE SA.

FOR BINDING INFORMATION ON MODELS,
TRIMMING AND COMPONENTS VALUES AND
NON-FITTED COMPONENTS SEE PARTS LIST.

DIESE ZEICHNUNG BEHALTEN SIE UNTER ALLE RECHTE VOR.
DIESE ZEICHNUNG IST EIN RECHNEPRESSENDRUCK. AENDERUNGEN KOENNEN NUR DURCH ENDEREN DES DATENSATZES ERFOLGEN.

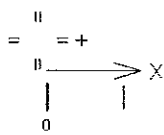
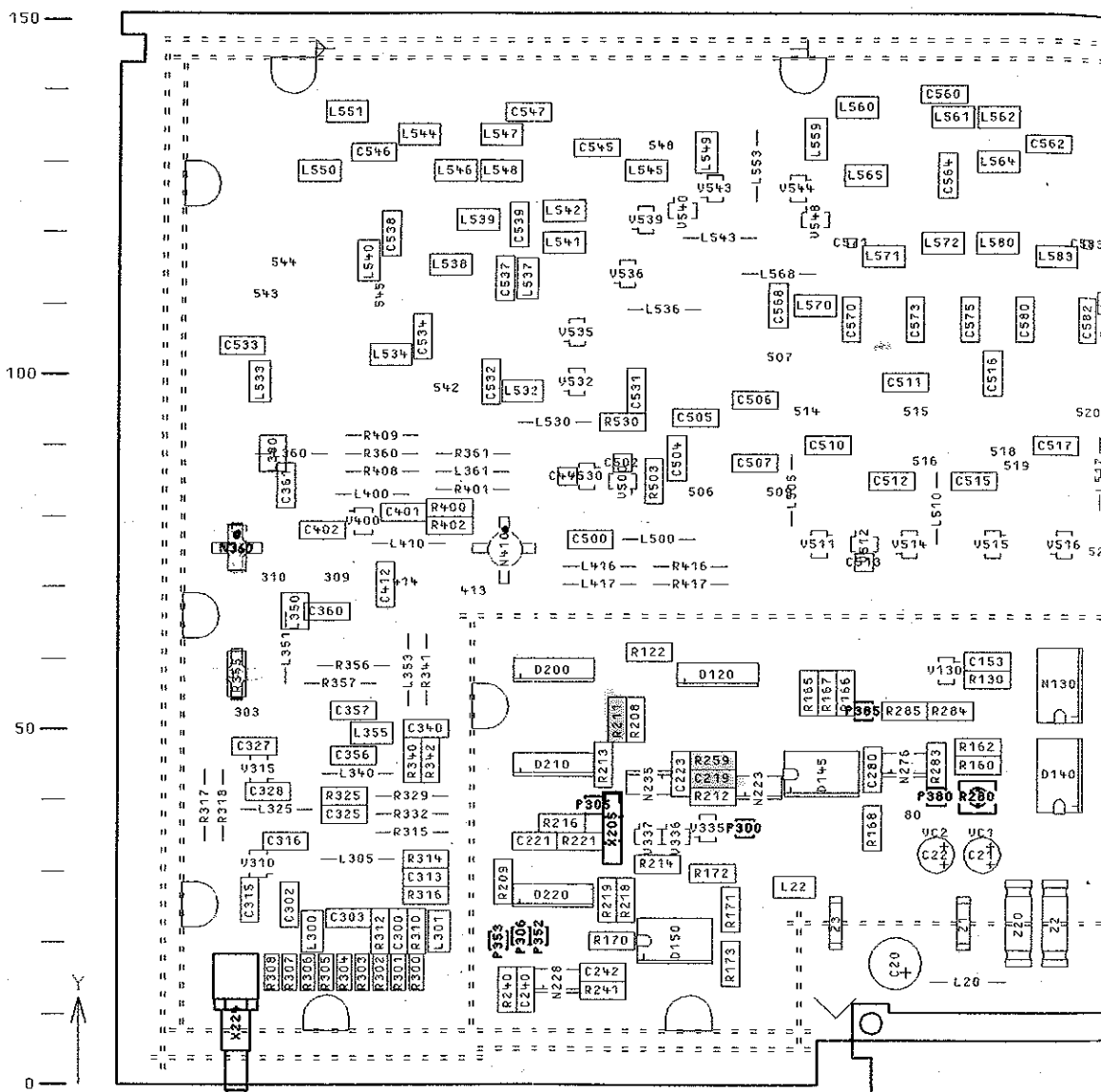

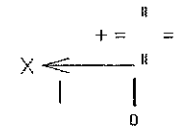
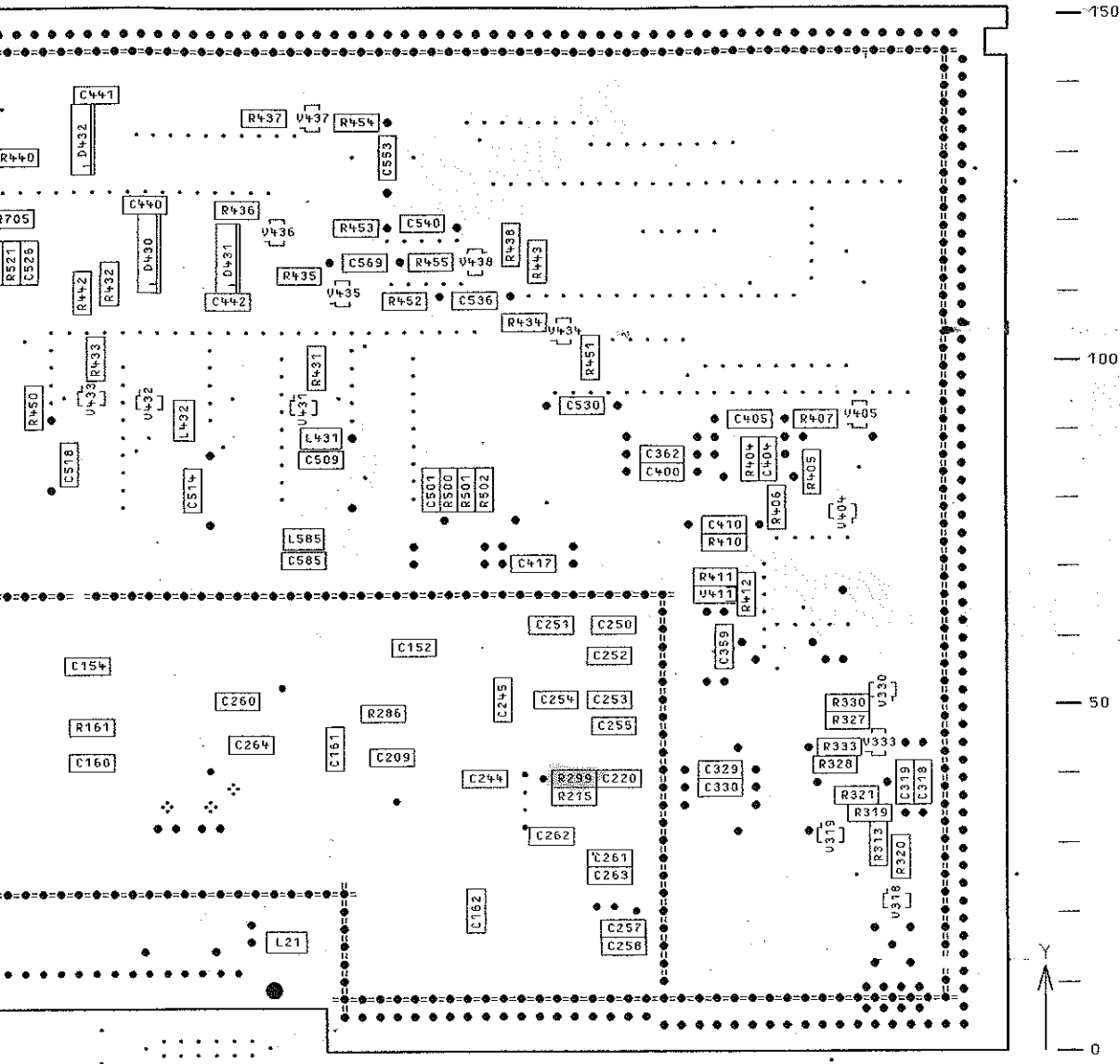

03/		11.07.96	DR	1GPK	TAG	NAME	BENENNUNG	
				BERPB.		DR		
				GEPP.				
				NDPA				
				PLDII	11.07.96			
02/		06.10.93	DR				ZEICHN.-NP.	
REND	RENDPUNGS-	DATUM	NABE		ROHDE & SCHWARZ			1062.6209.01
1RB	MITTEILUNG			ZU BEFR.	SMY			2+
							RES. 1 V	1062.5502
							EPSTE 2	1062.5502

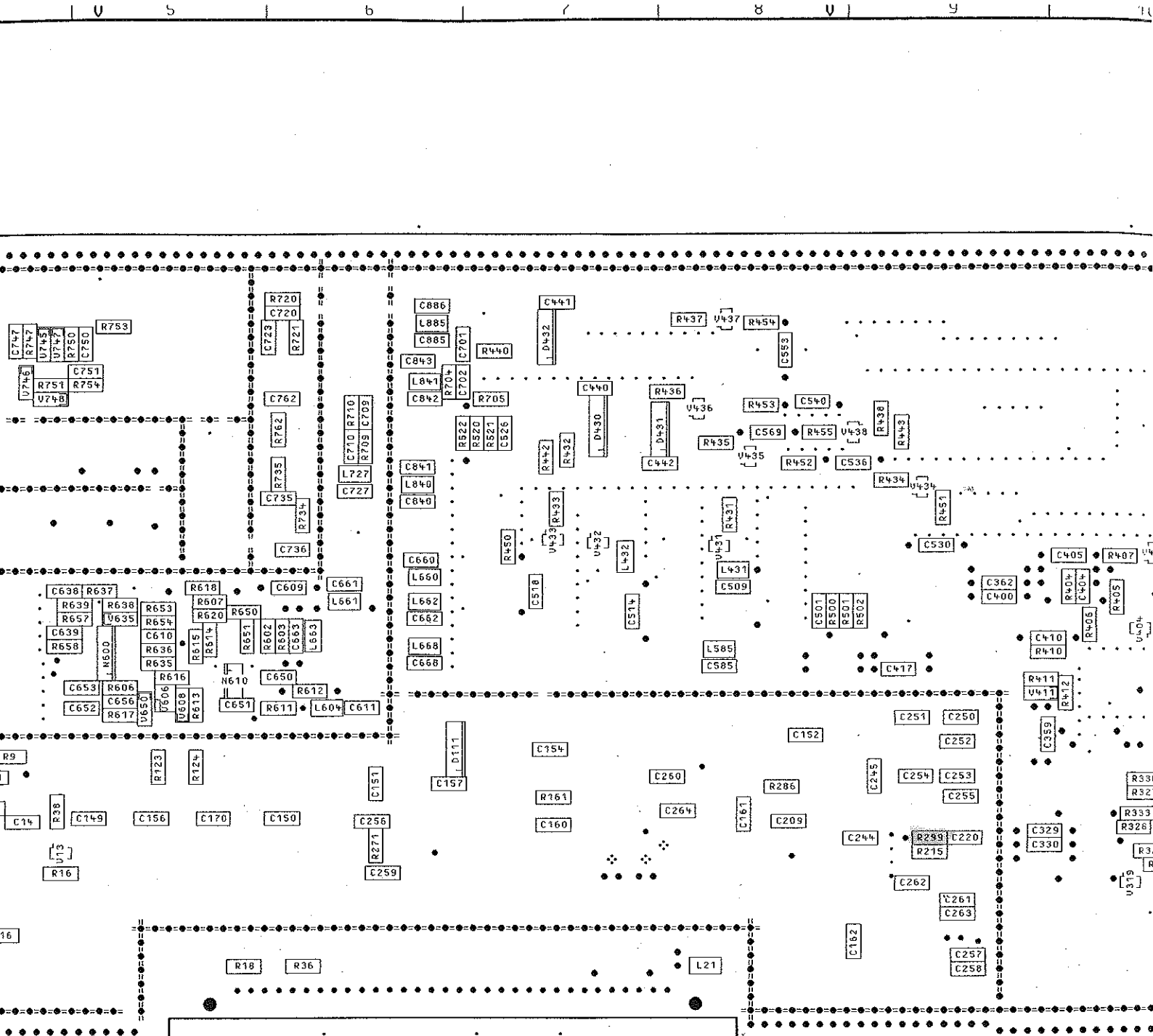

200 150 100 50

ANGABEN ÜBER VARIANTEN,
 TEILE, BRÜTEILWERTE UND
 STÜCKLISTE BRÜTEILE SIEHE SA.

ING INFORMATION ON MODELS,
 AND COMPONENTS VALUES AND
 D COMPONENTS SEE PARTS LIST.

03/		11.07.96	DR	16PK	1AG
				ACAPB:	
				GEPP:	
				NORA:	
				PLOTT:	11.07.96
02/		08.10.93	DR		
REND	RECHENUNGS-	DRIER	NARE		
IND.	MITTEILUNG				



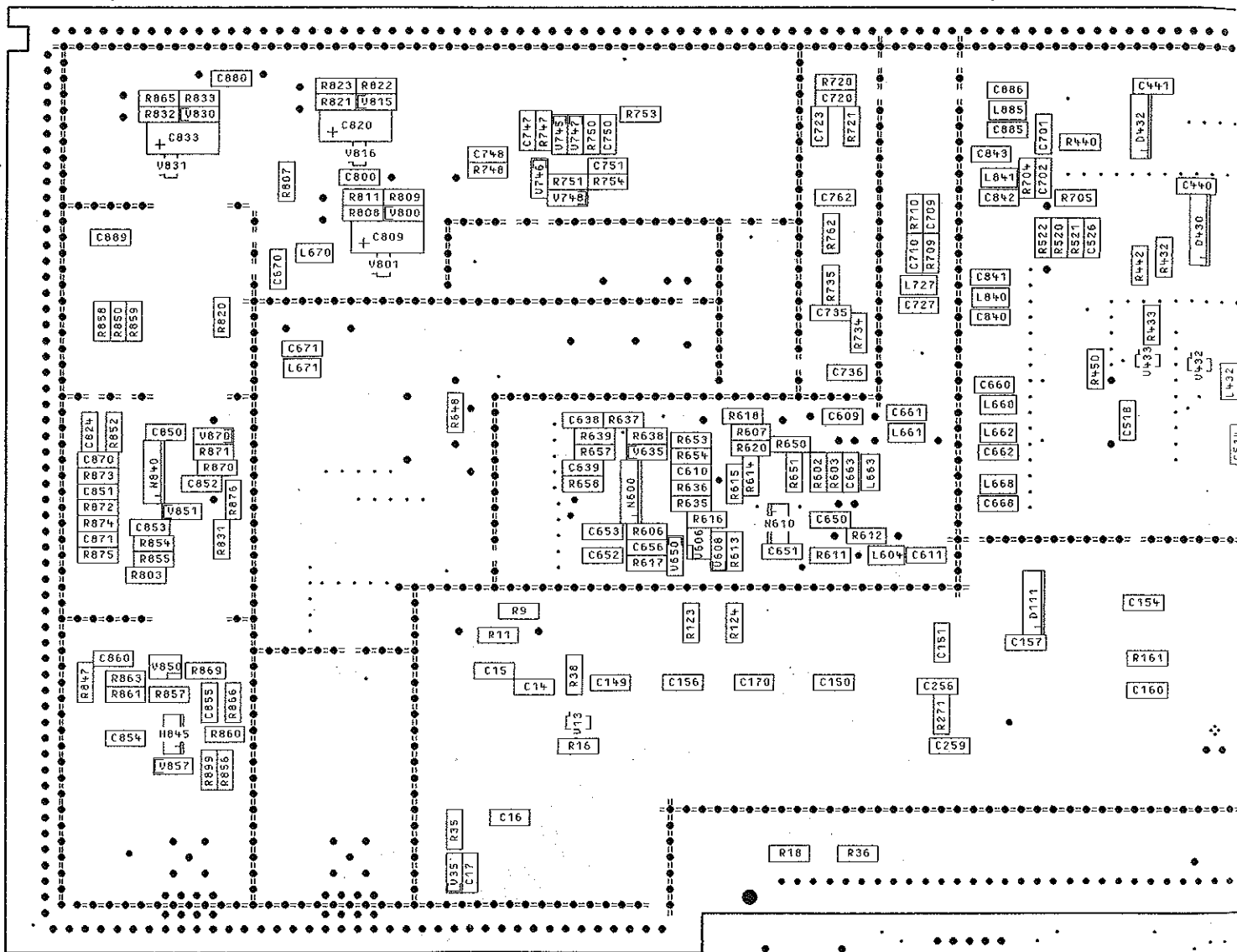

300

250

200

150

ELLUNG SEITE A
ON SIDE A



ACHTUNG: EGB!
ELEKTROSTATISCH GEFÄHRDETE
BAUKLEINTEILE ERFORDERN EINE
BESONDERE HANDHABUNG.
ATTENTION ESD!
ELECTROSTATIC SENSITIVE DEVICES
REQUIRE A SPECIAL HANDLING

BINDENDE ANGABEN ÜBER VARIANTEN,
TRIMMWERTE, BAUTEILWERTE UND
NICHT BESTÜCKTE BAUTEILE SIEHE SA.

FOR BINDING INFORMATION ON MODELS,
TRIMMING AND COMPONENTS VALUES AND
NONFITTED COMPONENTS SEE PARTS LIST.

Signal-Name	Page-No.:	Zones
+15VB1	02:	3F 06: 1A
+15VB2	06:	3A
+15VB4	08:	2E
+15VHH	09:	3B 6A 7A
+15VHI	09:	3B 10C
+5VB	05:	8C
+9V-I	07:	4A
-15VB1	02:	3E
-15VB3	05:	4E
-15VB4	08:	2D
-15VHI	09:	3A 6A 8A
-9V-I	07:	4B
ALCOFF	03:	1F 10: 7E
AM	02:	4C 03: 1D
AMINVERS	03:	1B 10: 3E
AMSLOW	03:	1F 10: 7E
BLANK	02:	4C 10: 1C
BLANKENABLE	10:	3E
BLANKINVERS	10:	3E
CLK1	02:	4B 10: 1E
DEFILT	02:	6D 08: 1E
DETMIXON	03:	1E 10: 7E
DETON	03:	1E
Druck 11.07.96	Abt.1GPK	Name DR Dat.11.07.96 Ae.Mi. Aei. 04
ROHDE & SCHWARZ	Benennung	AUSGANGSTEIL_1.046GHZ OUTPUT_UNIT_1.046GHZ 11+
Typ. SMY	Reg in Verz. 1062.5502	V Sachnummer 1062.6209 S



Signal-Name	Page-No.:	Zones			
DETON	10:	7E			
DIAG-0	02:	7E 10: 3E			
DIAG-1	02:	7E 10: 3E			
DIAG-2	02:	7E 10: 3E			
DIAG-3	02:	7E 10: 3E			
DIAGON	10:	3E			
HF-INT-ENABLE	02:	11C 10: 3E			
KLEMM-N	03:	1F 10: 8C			
LPSELECT-0	05:	8D 10: 7C			
LPSELECT-1	05:	8D 10: 7C			
LPSELECT-2	05:	8D 10: 7B			
LPSELECT-3	05:	8D 10: 7B			
MODUFIX	03:	10C 10: 7E			
RFLEVENABLE	10:	7E			
RFLOLEV	04:	12D 05: 1D			
SBDON	10:	5E			
SBDON-N	08:	1E 10: 11C			
SBDON-P	08:	1E 10: 11D			
SEROUT	02:	4C 10: 1E			
SIG10	05:	7D			
Druck 11.07.96	Abt.1GPK	Name DR	Dat.11.07.96	Ae.Mi.	Aei. 04
ROHDE & SCHWARZ	Benennung	AUSGANGSTEIL_1.046GHZ OUTPUT_UNIT_1.046GHZ		12+	
Typ. SMY	Reg in Verz.	1062.5502	V	Sachnummer	1062.6209 S

Signal-Name	Page-No. : Zones
SIG10	06: 1E
SIG80-1	06: 12E 08: 1C
SIG80-2	07: 1D 08: 5C
SIG80-3	07: 12D 08: 10B
SIG80-4	08: 11D 09: 1D
TP1	05: 12E 06: 4F
TP2	05: 12E 06: 6F
TP3	05: 12D 06: 7F
TP4	05: 12D 06: 2C
TP5	05: 12D 06: 3C
TP6	05: 12D 06: 5C
TP7	05: 12C 06: 7C
TP8	05: 12C 06: 10C
ULPRE	02: 11E 03: 12E 05: 4E
UMODULATOR	02: 11E 03: 12C 04: 6E
UREF6	03: 9F 10: 11B
UREF6N	03: 4C 10: 11B
UREF9	09: 5C 12B
Druck 11.07.96	Abt.1GPK Name DR Dat.11.07.96 Ae.Mi. Aei. 04
ROHDE & SCHWARZ	Benennung AUSGANGSTEIL_1.046GHZ OUTPUT_UNIT_1.046GHZ 13+
Typ. SMY	Reg in Verz. 1062.5502 V Sachnummer 1062.6209 S

Signal-Name	Page-No.: Zones
UREF9N	09: 5A 6B 12C
UREGELVERST	02: 6C 03: 12B
URF-SOLL	02: 11E 03: 7C
VDET	02: 11E 03: 1E 09: 8B
VDETMIX	02: 11E 03: 1F
VDETMIXE	07: 4C
VDEXT	02: 4F 03: 1E
VDEXTON	03: 1E 10: 7E
WR1	02: 4B 10: 1E

Druck 11.07.96	Abt.1GPK	Name DR	Dat.11.07.96	Ae.Mi.	Aei. 04
ROHDE & SCHWARZ	Benennung	AUSGANGSTEIL_1.046GHZ OUTPUT_UNIT_1.046GHZ		14-	
Typ. SMY	Reg in Verz.	1062.5502	V	Sachnummer	1062.6209 S

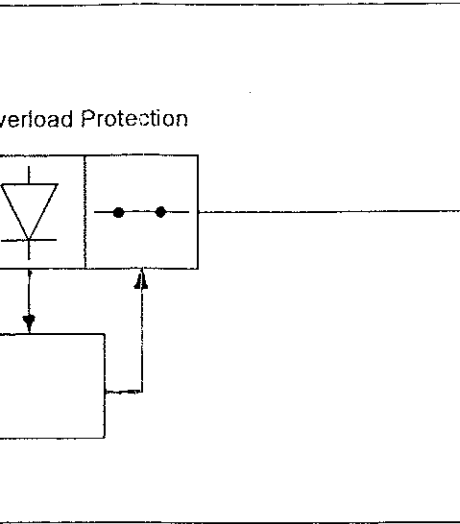

W1

X2

C

1 GPK	TAG	NAME	BENENNUNG	
BEARB.		JN	SIGNALGENERATOR_SMY	
GEPR.		JN	SIGNALGENERATOR_SMY	
NORM			top	
PLOTT	27.09.94		ZEICHN.-NR.	
 ROHDE & SCHWARZ			1062.5502.00 FS.	
			ERSTE Z.	
ZU GERÄT SMY			REG.I.V. 1062.5502	BLATT-NR. 1 V. 1 B.

V26
 kHz to 2080MHz
 3 to 20dBm

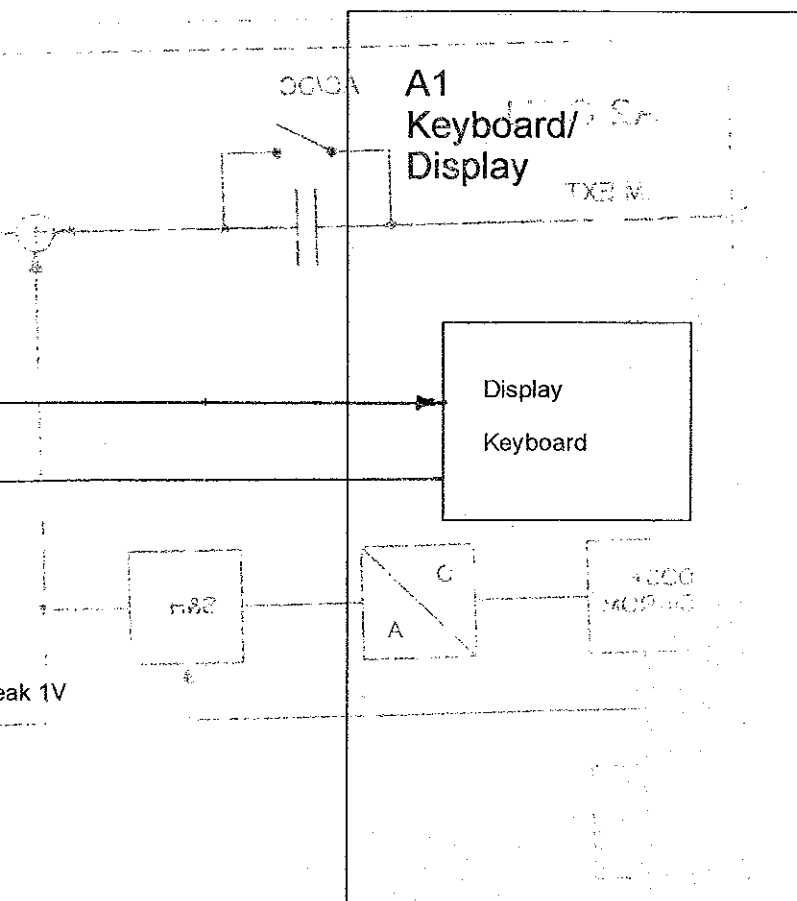
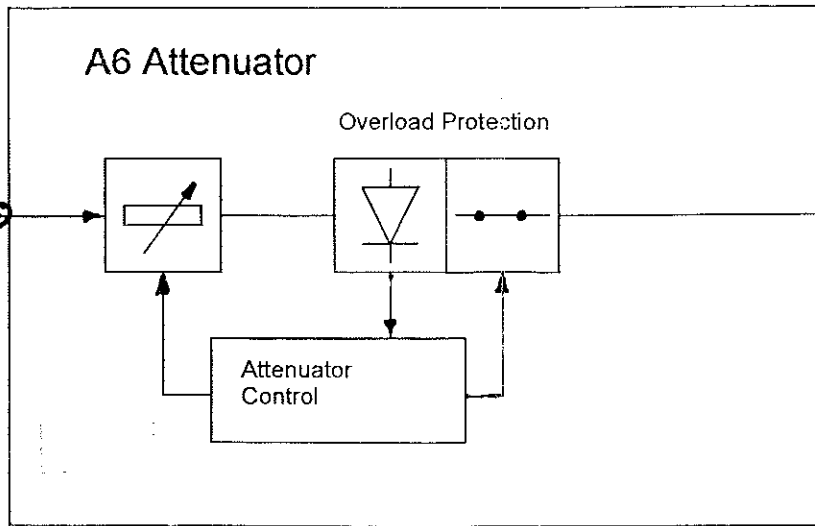

10PK	TAG	NAME	BENE
BEARB.		JN	SIC
GEPR.		JN	SIG
NORM			top
PLOTT	27.09.94		ZEICH
 ROHDE & SCHWARZ			REG.I.
ZU BENNET SMY			

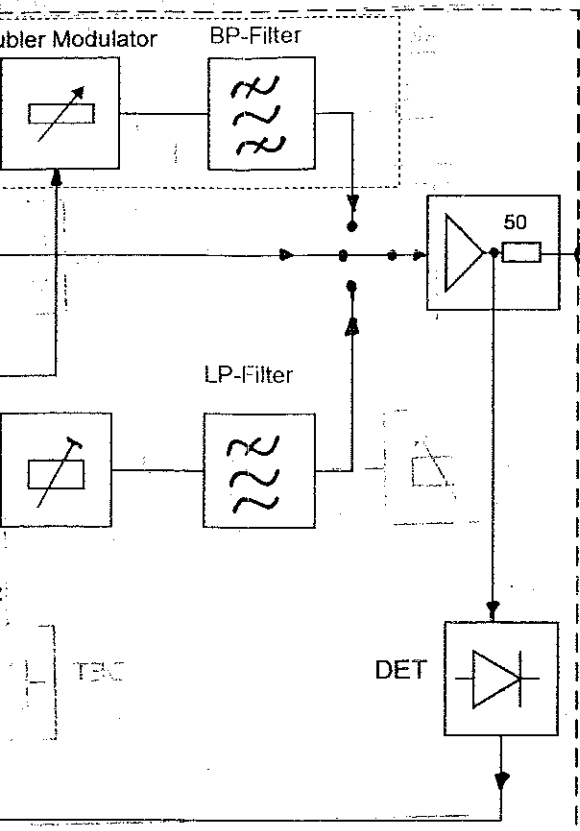

W26
 5kHz to 2080MHz
 -6 to 20dBm
 X1
 X226

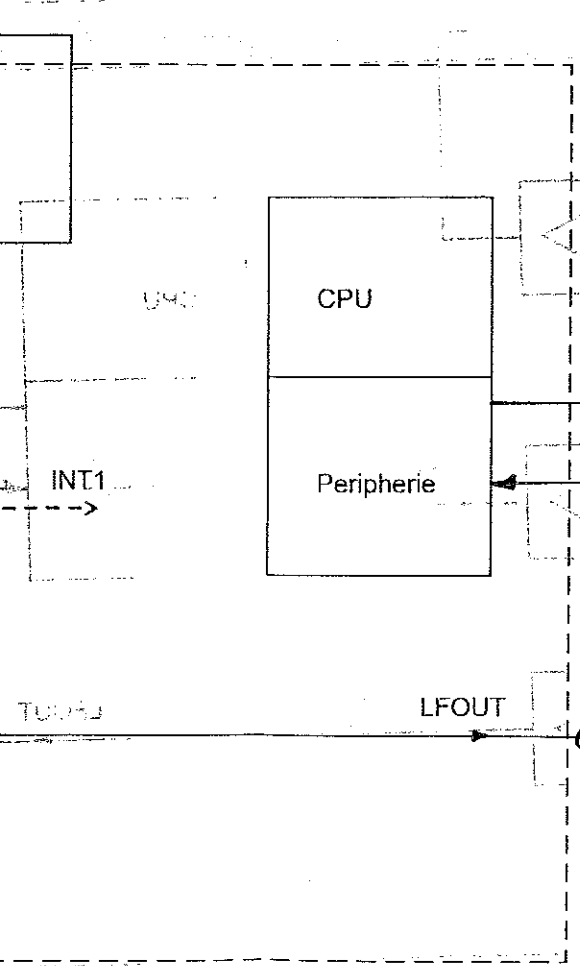
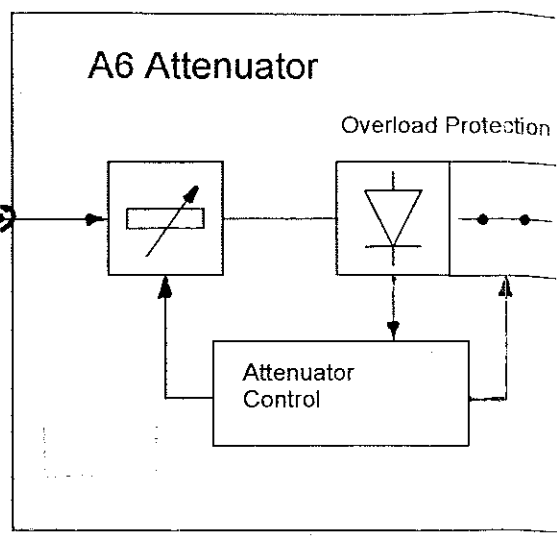

U90
 INT1
 Upeak 1V
 LFOUT
 C

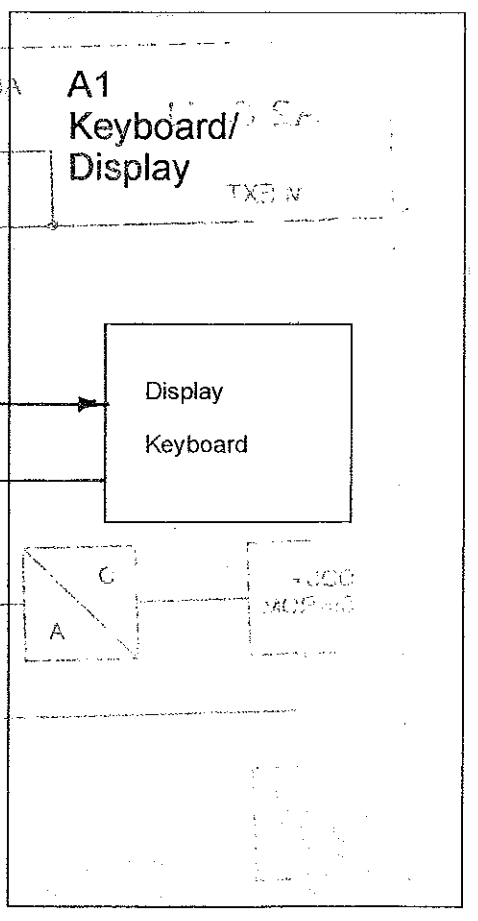

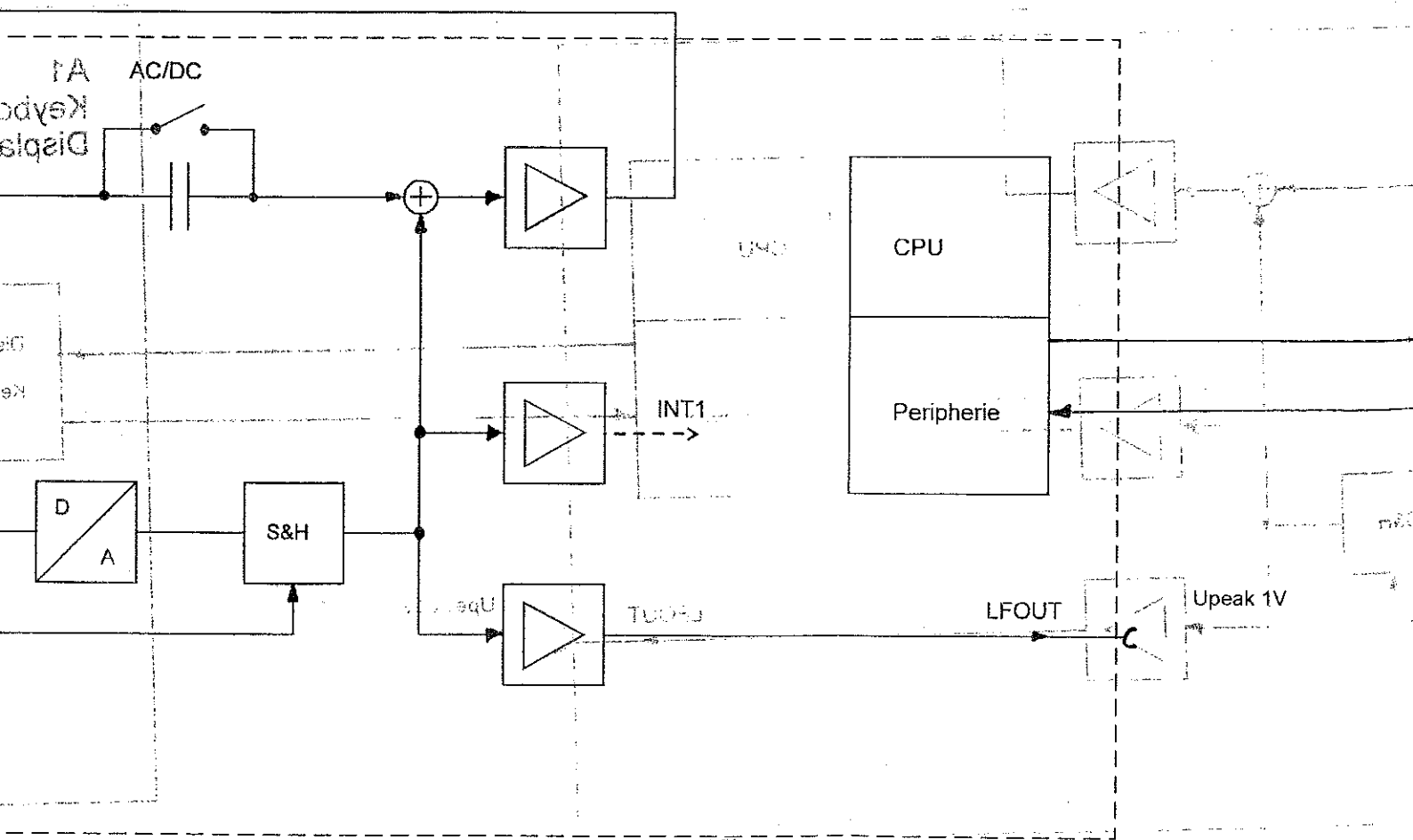
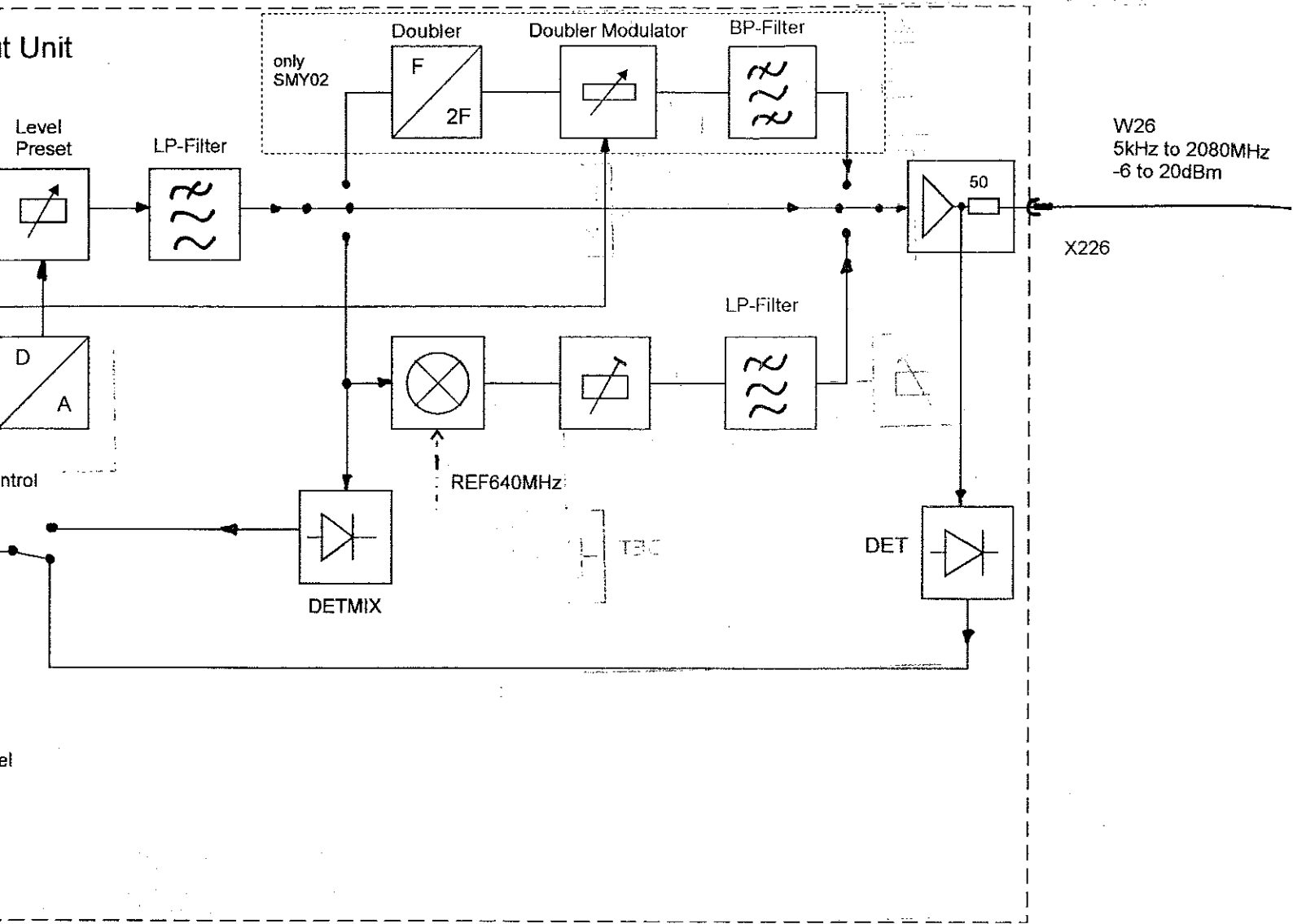

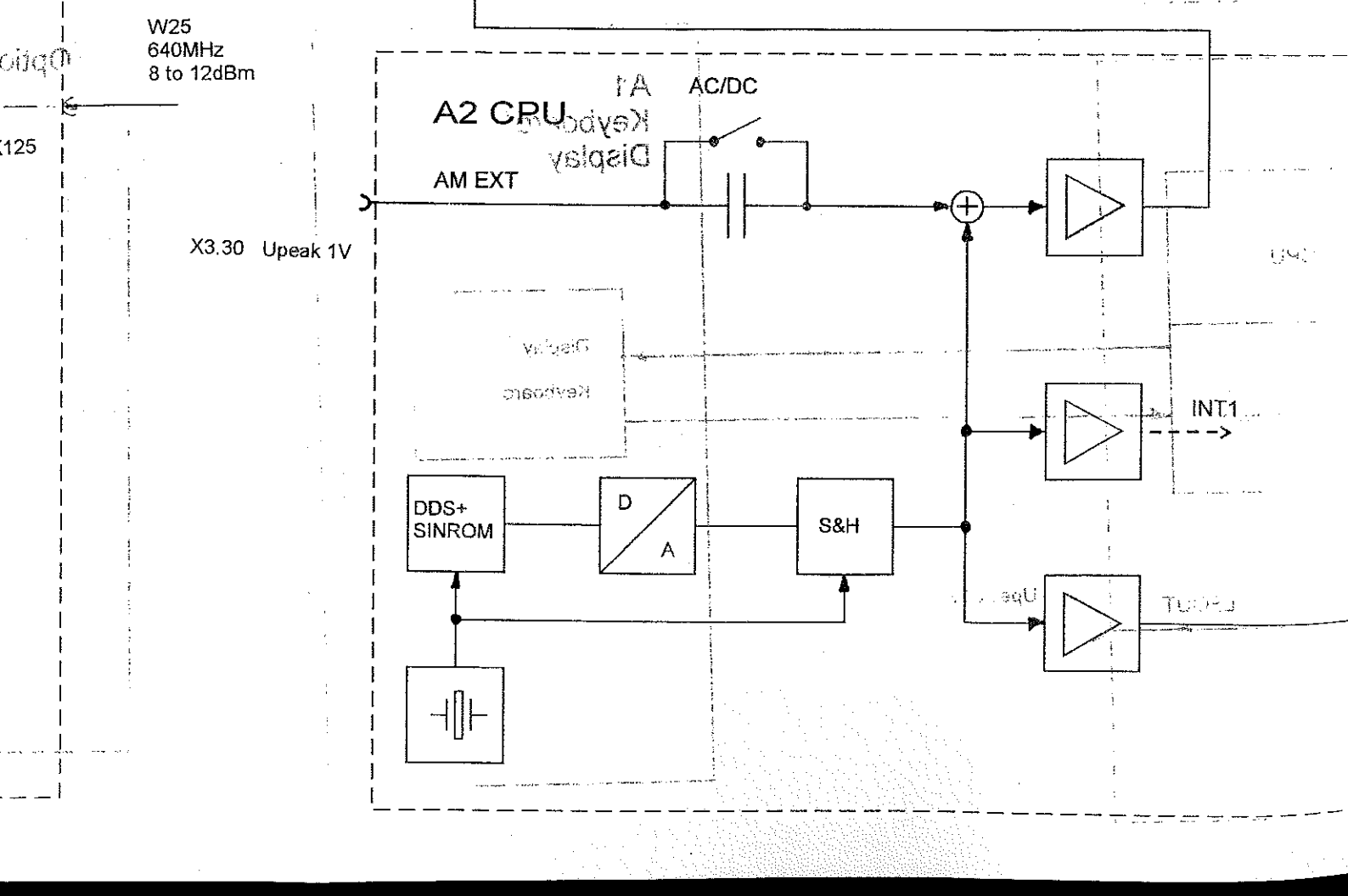
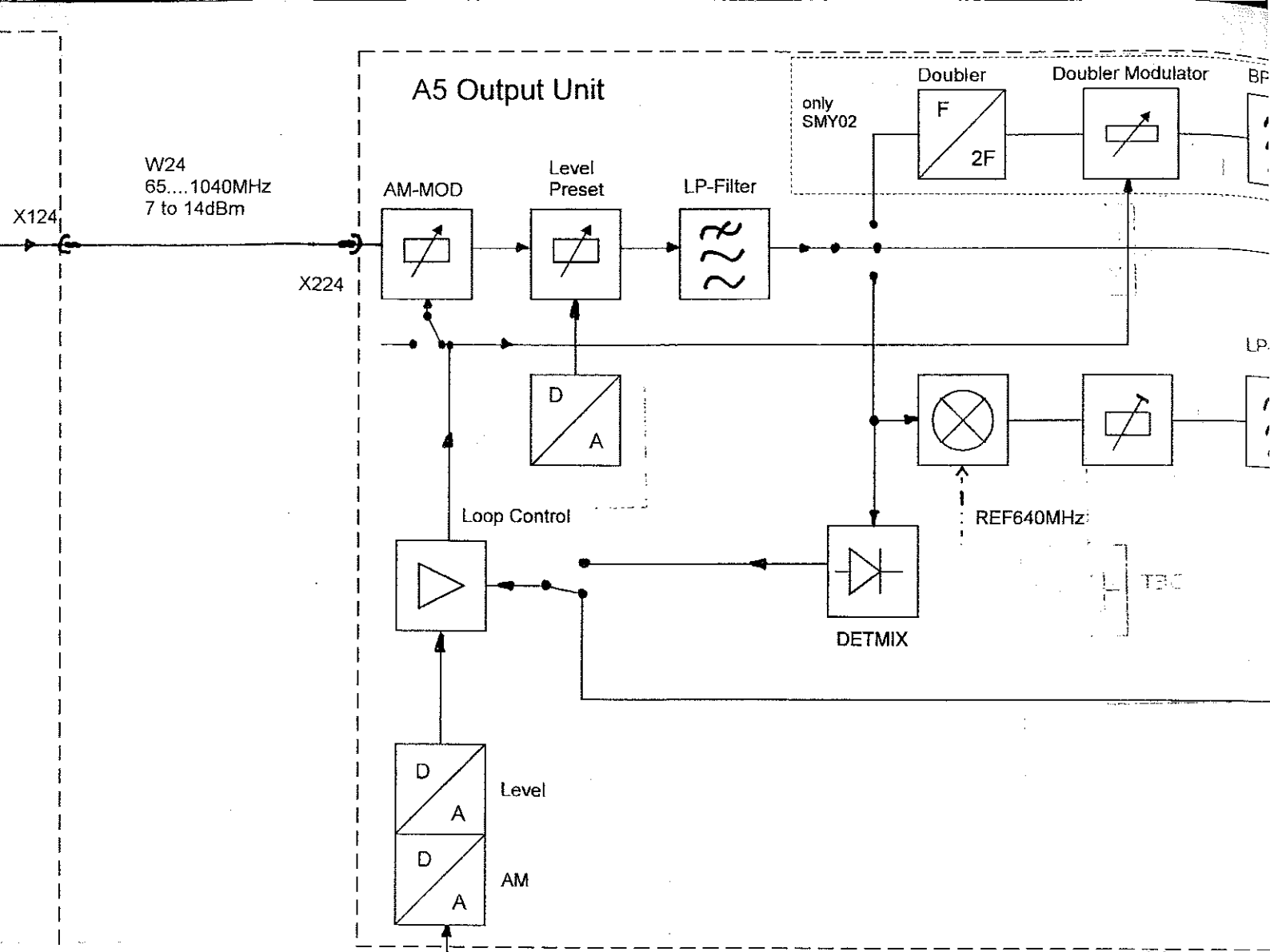

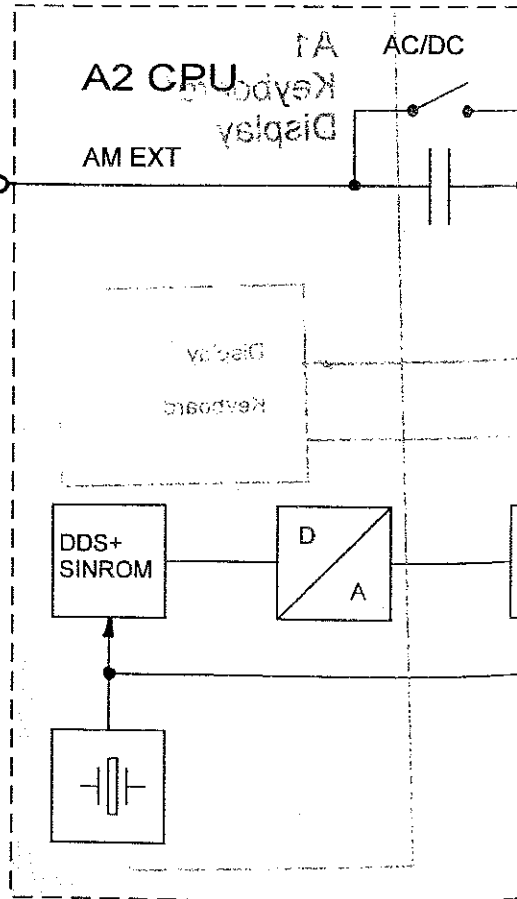
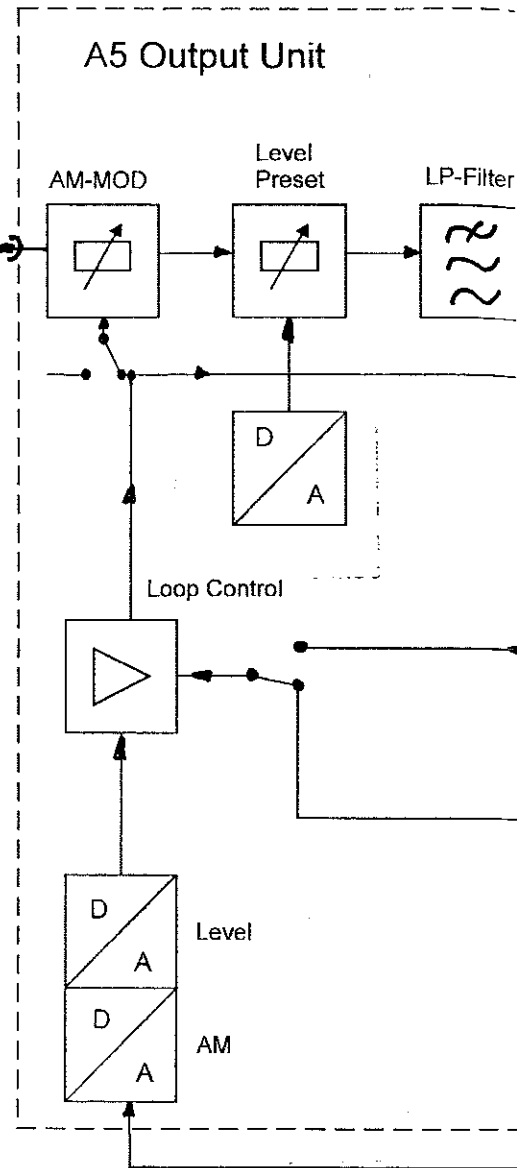
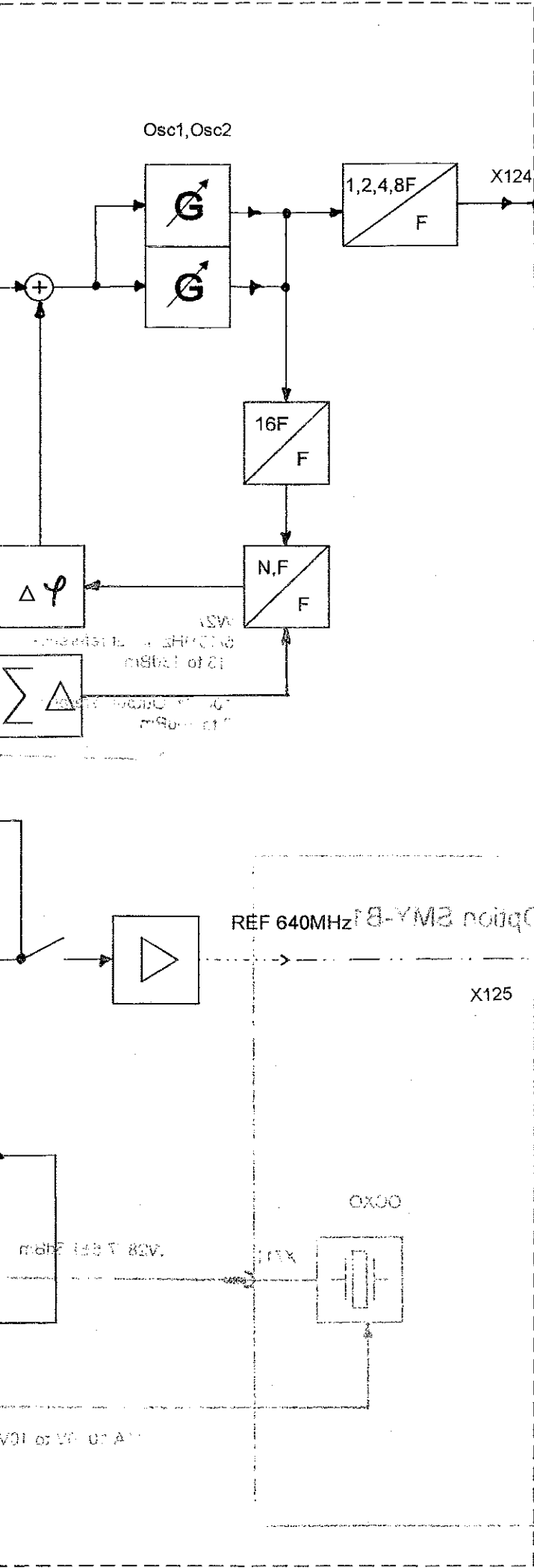

W24
65...1040MHz
7 to 14dBm

W25
640MHz
8 to 12dBm

X3.30 Upeak 1V

sis

100V 1A

T

Osc1, Osc2

W24
65...1040MHz
7 to 14dBm

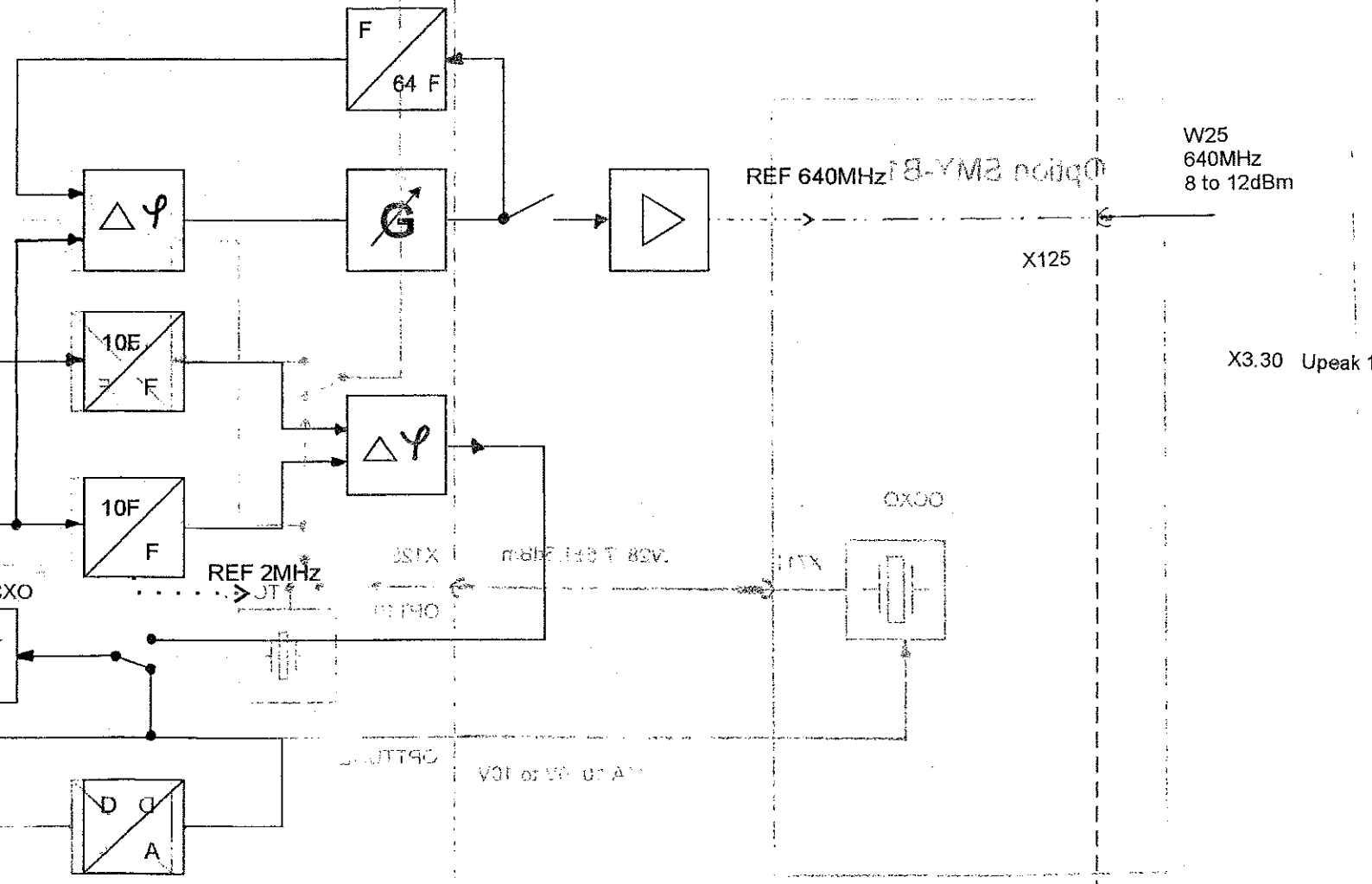
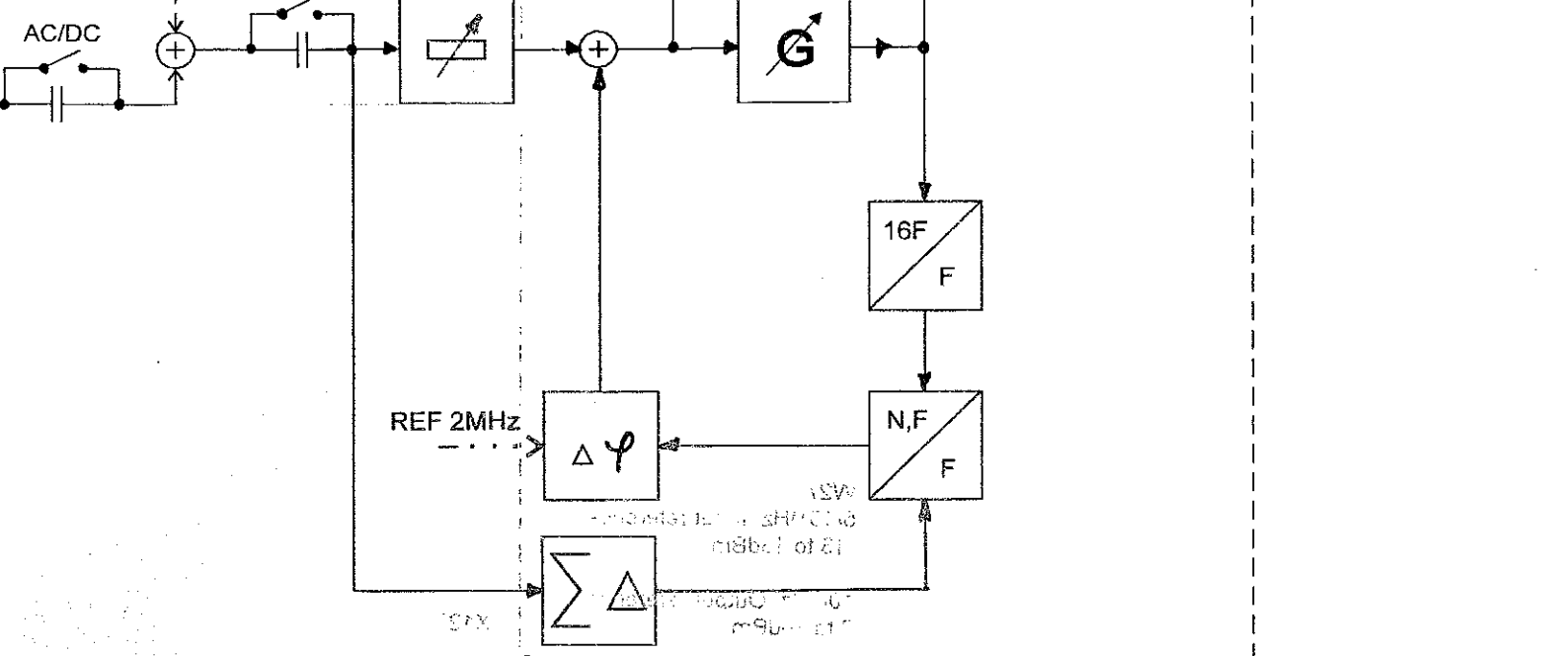

W25
640MHz
8 to 12dBm

X3.30 Upeak 1

A4 Synthesis

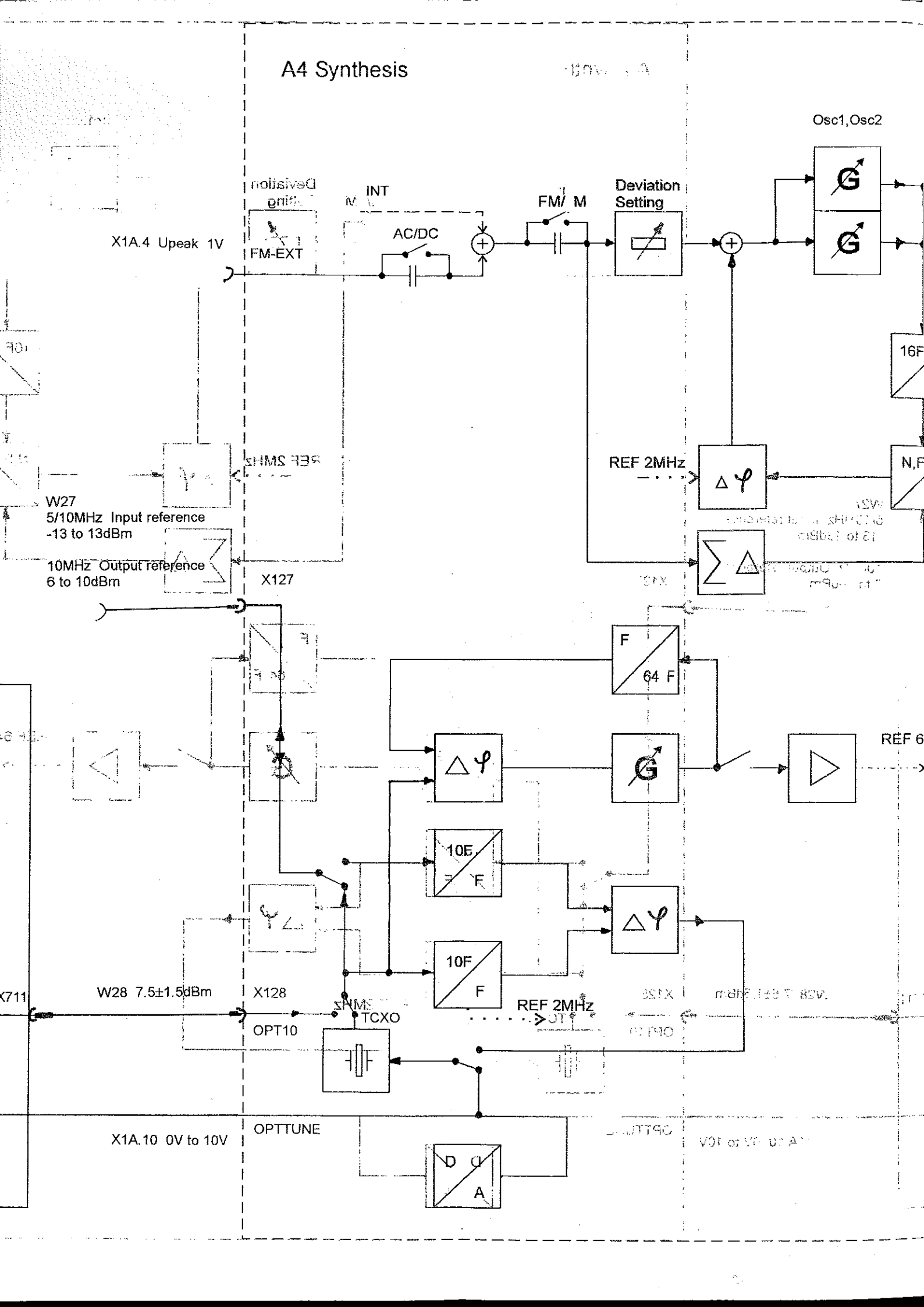

A4 Synthesis

Block Diagram

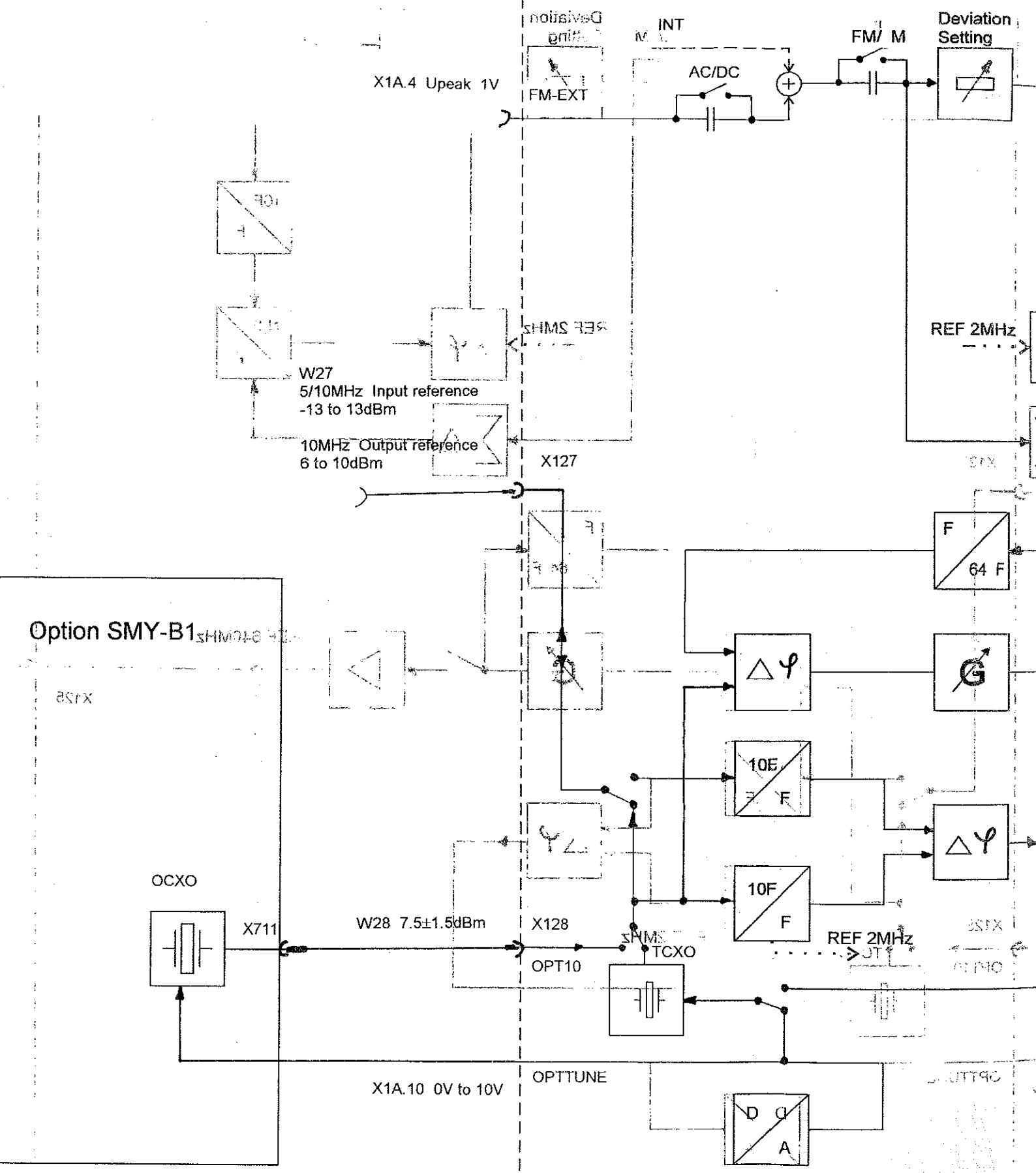

A4 Synthesis

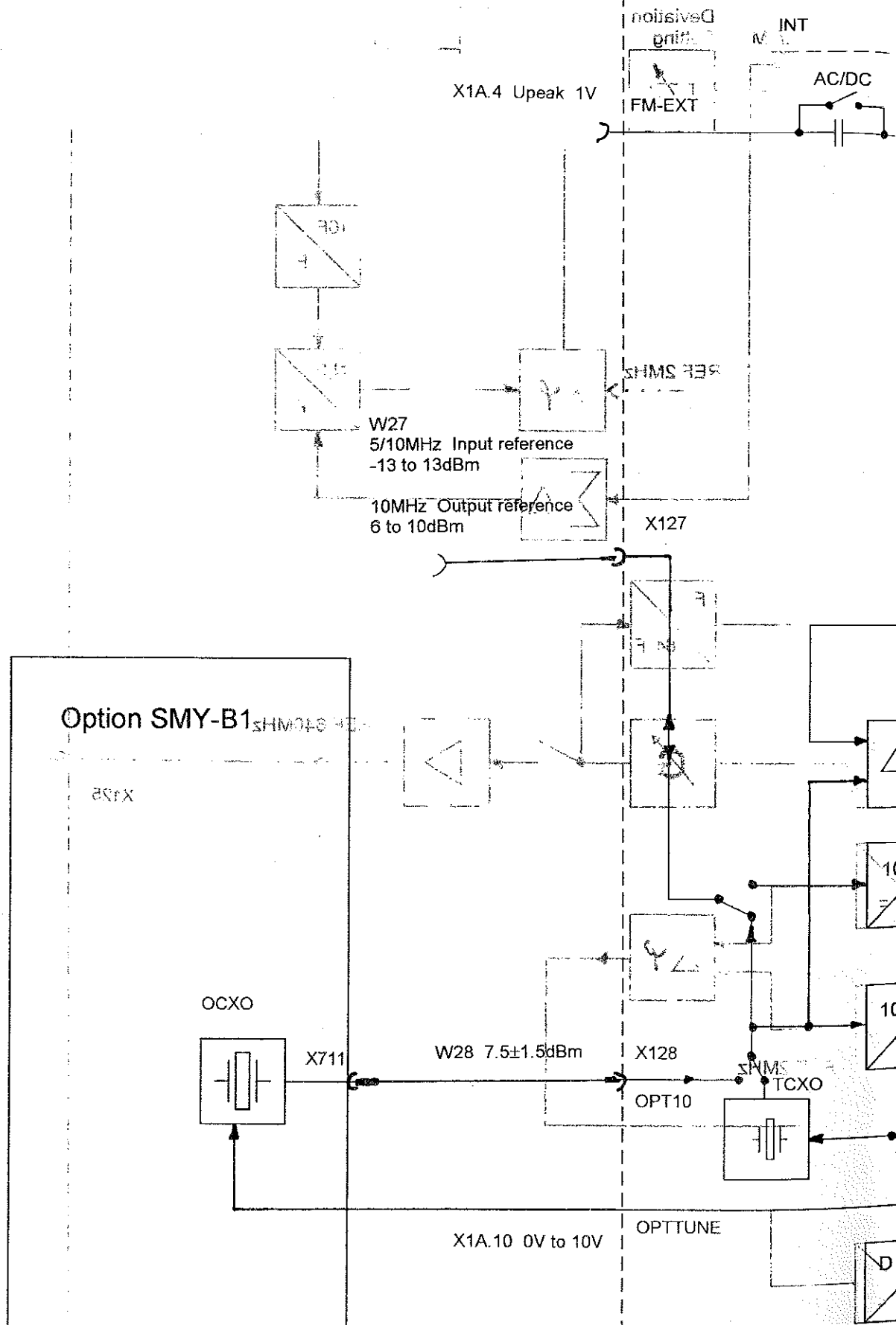



ROHDE & SCHWARZ

Geschäftsbereich
Meßtechnik

Servicehandbuch

Signal Generator AM / FM / PHIM

SMY01

9 kHz - 1040 MHz
1062.5502.11

SMY02

9 kHz - 2080 MHz
1062.5502.12

SMY43

9 kHz - 2080 MHz
1062.5502.43

ENGLISH SERVICE MANUAL FOLLOWS FIRST COLOURED DEVIDER

*Band 2
Servicehandbuch besteht aus 2 Bänden*

Printed in the Federal
Republic of Germany

Inhaltsübersicht

Band 1

Sicherheitshinweise Beiblatt

- 6 Serviceanleitung des Gesamtgerätes
- 7 Serviceanleitung der Baugruppen

Baugruppe	Register
A2 Rechner	1
A1 Anzeige-Tastatur.....	2
A4 Synthesizer	3
A5 Ausgangsteil 1.04 GHz	4

Band 2

Sicherheitshinweise

Baugruppe	Register
A5 Ausgangsteil 2.08 GHz	1
A6 Eichleitung 1 GHz	2
A6 Eichleitung 2 GHz	3
A7 Netzteil.....	4
A8 Referenzoszillator.....	5
A12 Power Modul	6



ROHDE & SCHWARZ

Test and Measurement
Division

Service Manual

SMY01

9 kHz to 1040 MHz
1062.5502.11

SMY02

9 kHz - 2080 MHz
1062.5502.12

SMY43

9 kHz to 2080 MHz
1062.5502.43

*Volume 1
Service manual consists of 2 volumes*

Printed in the Federal
Republic of Germany

Contents

Volume 1

Safety Instructions Supplement

6 Repair of Complete Instrument

7 Testing and Repair of Modules

Module	Tabbed Divider
A2 CPU.....	1
A1 Display- Keyboard	2
A4 Synthesizer	3
A5 Output Unit 1.04 GHz.....	4

Volume 2

Safety Instructions

Module	Tabbed Divider
A5 Output Unit 2.08 GHz.....	1
A6 Attenuator 1 GHz.....	2
A6 Attenuator 2 GHz.....	3
A7 Power Supply.....	4
A8 Reference Oscillator	5
A12 Power Module	6

Safety Instructions

This unit has been designed and tested according to the standards outlined overleaf and has left the manufacturer's premises in a state fully complying with the safety standards.

In order to maintain this state and to ensure safe operation, observe the following instructions, symbols and precautions.

- 1) When the unit is to be permanently cabled, first connect protective ground conductor before making any other connections.
- 2) Built-in units should only be operated when properly fitted into the system.
- 3) For permanently cabled units without built-in fuses, automatic switches or similar protective facilities, the AC supply line shall be fitted with fuses rated to the units.
- 4) Before switching on the unit ensure that the operating voltage set at the unit matches the line voltage.
If a different operating voltage is to be set, use a fuse with appropriate rating.
- 5) Units of protection class I with disconnectible AC supply cable and plug may only be operated from a power socket with protective ground contact.
The protective ground connection should not be made ineffective by an extension cable.
Any breaking of the protective ground conductor within or outside of the unit or loosening of the protective ground connection may cause the unit to become electrically hazardous.
The protective ground conductor shall not be interrupted intentionally.
- 6) Before opening the unit, isolate it from the AC supply.
Adjustment and replacement of parts as well as maintenance and repair should be carried out only by specialists approved by R & S.
Observe safety regulations and rules for the prevention of accidents.
Use only original parts for replacing parts relevant to safety (e.g. power on/off switches, power transformers or fuses).
- 7) Also observe the additional safety instructions specified in this manual.

Explanation of Symbols Used



- Read operating manual, observe the safety symbols used



- Caution, shock hazard



- Protective ground connection



- Unit ground



- Equipotential (floating ground)



- Ground

Patent Information

This product contains technology licensed by Marconi Instruments LTD. under US patents 4609881 and 4870384 and under corresponding patents in Germany and elsewhere.



ROHDE&SCHWARZ

SERVICEUNTERLAGEN

Ausgangsteil 2.08 GHz

1062.7005.01

Inhaltsverzeichnis

7 Prüfen und Instandsetzen der Baugruppe	5
7.1 Funktionsbeschreibung	5
7.1.1 RF-Signalverarbeitung.....	5
7.1.2 Mischer mit LO-, RF- und ZF-Filtern.....	6
7.1.3 Ausgangsverstärker.....	6
7.1.4 AM-Signalzweig und RF-Pegel-Sollwert.....	6
7.1.5 RF-Pegelregelung.....	6
7.1.6 serielle Schnittstelle.....	7
7.1.7 Schaltung zur Diagnoseauswahl.....	7
7.2 Meßgeräte und Hilfsmittel	7
7.3 Fehlersuche	8
7.3.1 Fehler nur im Bereich $f_{RF} < 10$ MHz.....	8
7.3.2 Fehler nur im Bereich $f_{RF} < 65$ MHz.....	8
7.3.3 Fehler im Bereich $5 \text{ kHz} \leq f_{RF} \leq 1040$ MHz.....	8
7.3.4 Fehler im Bereich $1040 \text{ MHz} < f_{RF} \leq 2080$ MHz.....	9
7.3.5 Spektrale Reinheit, $\Delta f < 10$ MHz vom Träger.....	10
7.4 Prüfen und Abgleich	10
7.4.1 Prüfen der Datenübertragung.....	11
7.4.2 Prüfen der Ausgangsspannung des Regelverstärkers.....	11
7.4.3 Prüfen der LEVEL PRESET-Steuerspannung.....	11
7.4.4 Prüfen der Arbeitspunkte der Verstärkerstufen.....	12
7.4.5 Prüfen der Ansteuerung der Filterbank.....	12
7.4.6 Prüfen des RF-Pegels nach der Filterbank.....	13
7.4.7 Prüfen der Ansteuerung der Bandpaßschalter.....	13
7.4.8 Abgleich der ZF-Verstärkung.....	14
7.4.9 Abgleich der ZF-Detektor-Linearität.....	14
7.4.10 Abgleich der Detektor-Linearität am Ausgang FOPU... ..	14
7.4.11 Abgleich des AM-Modulationsgrades.....	15
7.5 Zerlegung und Zusammenbau	15
7.6 Endprüfung	15
7.6.1 Prüfen des maximalen Ausgangspegels.....	15
7.6.2 Prüfen des Oberwellenabstandes.....	16
7.6.3 Prüfen des Nebenwellenabstandes.....	16
7.6.4 Prüfen des Subharmonischenabstandes.....	17
7.7 Externe Schnittstellen	18

Schalteilliste
Koordinatenliste
Stromlauf
Bestückungsplan

Bei Geräten ohne Option SMY-B40 hat die Baugruppe die Variante VAR02.

Bei Geräten mit Option SMY-B40 hat die Baugruppe die Variante VAR03.

7.1 Funktionsbeschreibung

Das Ausgangsteil 2.08 GHz erhält über den Eingang FSYN von der Baugruppe Synthese das RF-Signal (6 dBm ... 12 dBm) im Frequenzbereich $65 \text{ MHz} \leq f_{\text{SYN}} \leq 1040 \text{ MHz}$. Dieses RF-Signal wird über einen Amplitudenmodulator und ein Amplitudenstellglied auf schaltbare Tiefpaßfilter gegeben. Im Signalzweig wird durch die Umschalter SWITCHB und SWITCHD der Ausgangsfrequenzbereich $5 \text{ kHz} \leq f_{\text{RF}} < 65 \text{ MHz}$ durch Abmischen mit einem 640 MHz-LO erzeugt. Über die Umschalter SWITCHA und SWITCHC kann der Verdopplerpfad eingeschaltet werden, um den Ausgangsfrequenzbereich $1040 \text{ MHz} < f_{\text{RF}} \leq 2080 \text{ MHz}$ zu realisieren.

Die Baugruppe enthält folgende Funktionseinheiten:

- Einen AM-Modulator zur Pegelregelung und Amplitudenmodulation im Frequenzbereich $5 \text{ kHz} \leq f_{\text{RF}} \leq 1040 \text{ MHz}$,
- einen AM-Modulator zur Pegelvoreinstellung (LEVEL PRESET),
- schaltbare Tiefpässe zur Unterdrückung von Harmonischen,
- einen Mischer mit LO-, RF- und ZF-Filtern,
- einen Pegeldetektor im RF-Zweig vor dem Mischer,
- einen Frequenzverdoppler,
- Einen AM-Modulator zur Pegelregelung und Amplitudenmodulation im Frequenzbereich $1040 \text{ MHz} < f_{\text{RF}} \leq 2080 \text{ MHz}$,
- schaltbare Bandpässe zur Unterdrückung von Subharmonischen,
- einen Ausgangsverstärker,
- einen Pegeldetektor am Ausgang FOPU,
- einen Signalzweig zur Einstellung des RF-Pegelsollwertes und des Amplitudenmodulationsgrades,
- die RF-Pegelregelung,
- eine serielle Schnittstelle und
- eine Schaltung zur Diagnoseauswahl.

Im weiteren Text enthaltene Pegelangaben gelten für einen Geräteausgangspegel von +13 dBm (+19 dBm mit Option SMY-B40).

7.1.1 RF-Signalverarbeitung

Dem Eingang X224 FSYN ist ein Dämpfungsglied zur Temperaturkompensation nachgeschaltet. Anschließend folgt der AM MODULATOR.

Er ist das Stellglied der Pegelregelung im Bereich $f_{\text{RF}} \leq 1.04 \text{ GHz}$. Das RF-Signal wird durch RF AMPLIFIER 1 und RF AMPLIFIER 2 verstärkt und auf den PIN-Modulator LEVEL PRESET gegeben. Dieser Modulator wird durch gespeicherte Kalibrierdaten mittels D/A-Wandler so eingestellt, daß das Stellglied der Pegelregelung in einem optimalen Arbeitspunkt betrieben werden kann (vergl. Bedienhandbuch "Kalibrierung LEVEL PRESET").

Das RF-Signal wird durch den RF AMPLIFIER 3 verstärkt und auf schaltbare Tiefpässe HARMONIC FILTERS gegeben. Diese werden abhängig von der Eingangsfrequenz an X224 FSYN durch den Rechner eingeschaltet. Die Tiefpässe TP0 bis TP3 sind wie die Tiefpässe TP4 bis TP8 in Kette geschaltet. Filter in der Kette mit höherer Grenzfrequenz als der Grenzfrequenz des gewählten Tiefpasses bleiben eingeschaltet.

Im "Normalbetrieb" wird das RF-Signal über den PIN-Schalter SWITCHD (OFF) und den GaAs-Umschalter SWITCHB (OFF) auf den Ausgangsverstärker gegeben.

Im "Mischerbetrieb" wird das RF-Signal über PIN-Schalter SWITCHD (ON) und den RF AMPLIFIER 4 auf den Detektor vor dem Mischer geschaltet.

Im "Verdopplerbetrieb" wird das RF-Signal über den GaAs-Schalter SWITCHA (ON) auf den Verdoppler geschaltet. Dessen Ausgangssignal gelangt über den DOUBLER MODULATOR auf schaltbare Bandpässe und über den GaAs-Schalter SWITCHC (ON) zum Ausgangsverstärker.

7.1.2 Mischer mit LO-, RF- und ZF-Filtern

Das RF-Signal vom Detektor vor dem Mischer wird über den RF-Tiefpaß und ein Dämpfungsglied zur Pegelanpassung auf den RF-Eingang des Mixers geschaltet (Pegel ca. -5 ... -10 dBm). Das Signal von REF640 gelangt über einen Tiefpaß auf den LO-Eingang des Mixers. Über den ZF-Verstärker und den ZF-Tiefpaß wird das ZF-Signal auf den RF-Schalter SWITCHB (ON) vor dem Ausgangsverstärker geschaltet ($5 \text{ kHz} \leq f_{ZF} < 65 \text{ MHz}$, Pegel ca. 0 dBm).

7.1.3 Ausgangsverstärker

Der dreistufige lineare Breitbandverstärker verstärkt das Eingangssignal um ca. 19 dB. Die Arbeitspunkte der Stufen RF AMPLIFIER 12 und RF AMPLIFIER 13 werden geregelt.

7.1.4 AM-Signalzweig und RF-Pegel-Sollwert

Das Signal der Leitung AMMOD wird auf den D/A-Wandler zur Modulationsgradeinstellung gegeben und gelangt auf den D/A-Wandler RFLEV zur RF-Pegeleinstellung.

7.1.5 RF-Pegelregelung

Bei Geräten ohne Option SMY-B40 wird der Pegeldetektor am Ausgang X226 FOPU bei Gerätefrequenzen $f_{RF} \geq 10 \text{ MHz}$ verwendet. Der RF-Pegel an der Diode beträgt ca. +19 dBm.

Die Linearisierungsschaltung ermöglicht einen Dynamikbereich von ca. 30 dB bei guter Linearität (wichtig für geringen AM-Klirrfaktor).

Bei Geräten mit Option SMY-B40 wird für die Pegelregelung bei Gerätefrequenzen $\geq 10 \text{ MHz}$ der Detektor auf der Option SMY-B40 verwendet. Dessen Ausgangsspannung gelangt über das Kabel W125 zum Motherboard und von dort auf den Eingang X2.A5 DETEXT dieser Baugruppe.

Der Pegeldetektor im RF-Zweig vor dem Mischer wird bei Gerätefrequenzen $f_{RF} < 10$ MHz anstelle des Detektors am Ausgang X226 FOPU verwendet. Der RF-Pegel an der Diode beträgt ca. +15 dBm.

Die Pegelregelung erfolgt durch den PI-Regler N235. Der Führungswert wird vom D/A-Wandler RFLEV geliefert und mit dem Istwert von einem der drei Detektoren (VDET, DETEXT oder VDETMIX) je nach Frequenzbereich verglichen. Die Ausgangsspannung des PI-Reglers regelt das Stellglied nach:

Im Bereich $f_{RF} \leq 1040$ MHz ist der AM MODULATOR in Betrieb. Im Bereich $f_{RF} > 1040$ MHz ist der DOUBLER MODULATOR in Betrieb; zusätzlich wird durch das Steuersignal MODUFIX vom Rechner die Steuerspannung des AM MODULATORS auf einen festen Wert (ca. 14 V) geschaltet, um so minimale Dämpfung zu erreichen.

Die 3dB-Bandbreite der Regelschleife kann durch AMSLOW von ca. 300 kHz auf ca. 50 kHz reduziert werden (siehe Spezialfunktion 13).

Das Aktivieren von KLEMM-N durch den Prozessor steuert den AM-Modulator auf maximale Dämpfung, dies wird z.B. bei Frequenzwechseln zur Vermeidung von Pegelspikes verwendet.

7.1.6 Serielle Schnittstelle

Die ankommenden Daten werden in die Schieberegister und die D/A-Wandler LEVEL PRESET, RFLEV und AM getaktet.

7.1.7 Schaltung zur Diagnoseauswahl

Über den Diagnosemultiplexer kann eine von 8 Gleichspannungen auf die Diagnoseleitung gelegt werden. Der Spannungswert kann im Gerätedisplay angezeigt werden.

Spezialfunktion	Soll-Spannungsbereich	Hinweis
101	0.00 V ... 5 V	RF-Pegel vor Doubler Modulator
102	0.00 V ... 6 V	Detektorspannung Ausgang FOPU
103	0.00 V ... 6 V	Detektorspannung Mischer
104	0.01 V ... 3 V	RF-Pegel nach Filterbank
105	-6.00 V ... 0 V	Führungswert der Pegelregelung
106	-1.00 V ... 10 V	Ausgangsspannung des Regelverstärkers
107	-1.00 V ... 10 V	Steuerspannung des AM-Modulators
108	0.50 V ... 13 V	Steuerspannung des Stellgliedes LEVEL PRESET

7.2 Meßgeräte und Hilfsmittel

- Spektrumanalysator (z.B. FSBS)
- Oszilloskop (z.B. BOL)
- Gleichspannungsmessgerät (Multimeter, z.B. UDL33)
- Netzwerkanalysator (z.B. ZVR)
- RF-Pegelmessgerät (z.B. NRVD mit Meßkopf NRV-Z51)
- 10dB-N-Dämpfungsglied (z.B. DNF)

7.3 Fehlersuche

Vor dem Öffnen des Gerätes ist es zweckmäßig, zuerst einmal die Kalibrieroutine LEVEL PRESET zu starten und an Hand der Diagnosespannungen mögliche Fehlerquellen zu lokalisieren.

7.3.1 Fehler nur im Bereich $f_{RF} < 10$ MHz

- falscher RF-Pegel an X226** Der Detektor im Mischbereich liefert eine falsche Spannung oder der PI-Regler wird nicht richtig angesteuert.
Spannung VDETMIX mit Spezialfunktion 103 prüfen.
- schlechter AM-Klirrfaktor** Prüfe die Linearisierungsschaltung des Detektors.

7.3.2 Fehler nur im Bereich $f_{RF} < 65$ MHz

- falscher RF-Pegel an X226** Eingang REF640, ZF-Verstärker, RF-Verstärker 4 und die Ansteuerung SBDON-P und SBDON-N der Umschalter prüfen.
- Oberwellen zu groß** Prüfe ZF-Verstärker, ZF-Tiefpaß und RF-Schalter SWITCHB.
- Nebenwellen zu groß** Der Mischer ist defekt oder er wird mit zu hohem RF-Pegel angesteuert (Sollpegel am Mischer-RF-Eingang < -5 dBm). Prüfe ZF-Verstärker, ZF-Tiefpaß, RF-Schalter SWITCHB und den RF-Tiefpaß.

7.3.3 Fehler im Bereich $5 \text{ kHz} \leq f_{RF} \leq 1040$ MHz

- kein RF-Pegel an X226** Die Steuerspannung des AM-Modulators muß jetzt > 12 V sein, sonst arbeitet die Pegelregelung nicht richtig oder der Führungswert vom RFLEV-D/A-Wandler ist falsch. Pegel nach Filterbank prüfen (Spezialfunktion 104). Mit Spektrumanalysator mit RF-Tastkopf mit DC-Trennung die RF-Kette kontrollieren (die Sollverstärkung einzelner Verstärkerstufen beträgt ca. 7 dB)

Oberwellen zu groß

Prüfe Filterbank und folgende RF-Verstärker-Kette, prüfe Arbeitspunkte des Endverstärkers.

Stör-Phasenmodulation bei AM zu groß

Prüfe die Ansteuerspannung des AM-Modulators .
Kalibrierung LEVEL PRESET am Gerät durchführen.

AM-Klirrfaktor zu groß

Prüfen und Abgleich von Detektor und Linearisierungsschaltung, Kontrolle der AMSLOW-Ansteuerung.

AM-Klirrfaktor zu groß

Prüfen und Abgleich von Detektor und Linearisierungsschaltung, Kontrolle der

AMSLOW- AMSLOW-Ansteuerung.

7.3.4 Fehler im Bereich $1040 \text{ MHz} < f_{\text{RF}} \leq 2080 \text{ MHz}$

kein RF-Pegel an X226

Die Steuerspannung des AM-Modulators muß jetzt $> 12 \text{ V}$ sein, sonst arbeitet die Pegelregelung nicht richtig oder der Führungswert vom RFLEV-D/A-Wandler ist falsch. Pegel nach Filterbank prüfen (Spezialfunktion 104), Pegel vor Douber Modulator prüfen (Spezialfunktion 101). Umschalter SwitchA und SwitchC vor und nach den Bandpässen prüfen. Mit Spektrumanalysator mit RF-Tastkopf mit DC-Trennung die RF-Kette kontrollieren (die Sollverstärkung einzelner Verstärkerstufen beträgt ca. 7 dB)

Oberwellen zu groß

Prüfe Filterbank und folgende RF-Verstärker-Kette, prüfe schaltbare Bandpässe und die Umschalter SWITCHA und SWITCHC, prüfe Arbeitspunkt des Doubler Modulators, prüfe Arbeitspunkte des Endverstärkers.

Subharmonische zu groß

Prüfe schaltbare Bandpässe und die Umschalter SWITCHA und SWITCHC, prüfe Arbeitspunkt des Doubler Modulators, prüfe LEVEL PRESET-Spannung, Kalibrierung von LEVEL PRESET (Spezialfunktion 45) durchführen.

Stör-Phasenmodulation bei AM zu groß

Prüfe die Ansteuerspannung des AM-Modulators und die Ansteuerspannung des Doubler Modulators. Kalibrierung LEVEL PRESET am Gerät durchführen.

AM-Klirrfaktor zu groß

Prüfen und Abgleich von Detektor und Linearisierungsschaltung, Kontrolle der AMSLOW-Ansteuerung.

7.3.5 Spektrale Reinheit, $\Delta f < 10$ MHz vom Träger

Seitenlinien in ca. 1 MHz Abstand vom Träger

Pegel-Regelschleife schwingt; Prüfe Detektor und Linearisierungsschaltung. Kalibrierung LEVEL PRESET durchführen.

7.4 Prüfen und Abgleich

Vorbemerkung: Neben den Koppelkondensatoren bzw. -widerständen der RF-Kette befinden sich Massedurchkontaktierungen. An einer solchen Stelle kann ein Koaxialkabel eingelötet und über einen Koppelkondensator oder eine externe DC-Trennung ein Meßgerät (z.B. Netzwerk- oder Spektrumanalysator) angeschlossen werden. Hierzu wird das Koaxialkabel durch das Loch gesteckt, der Außenleiter des Koaxialkabels an der Durchkontaktierung und der Innenleiter am gewünschten Anschlußfleck des Kondensators angelötet.

7.4.1 Prüfen der Datenübertragung

Die Prüfung wird bei den in der Tabelle angegebenen Einstellungen am Gerät durchgeführt.

- Prüfen der Spannungen an D120:
"1" = +5 V, "0" = 0 V

RF-Frequenz	D120/14		D120/6 Hinweis
RF 1MHz	0	1	DETMIXON
RF 10MHz	1	0	DETON

7.4.2 Prüfen der Ausgangsspannung des Regelverstärkers

Um die Amplitudenmodulatoren optimal betreiben zu können ist die LEVEL PRESET-Kalibrierung erforderlich. Dieser optimale Arbeitspunkt ist abhängig vom Bereich der RF-Frequenz.

Im Frequenzbereich $f_{RF} \leq 1040$ MHz gilt:

Die Ausgangsspannung des Regelverstärkers soll bei einem Ausgangspegel von 13dBm (19 dBm mit Option SMY-B40) 6.3V betragen. Bei elektronischer Pegelabsenkung auf 7dBm (13 dBm mit Option SMY-B40) soll diese Spannung auf 3.9V absinken und bei weiterer elektronischer Pegelabsenkung bis zu -6dBm (0 dBm mit Option SMY-B40) konstant auf 3.9V bleiben.

Im Frequenzbereich $f_{RF} > 1040$ MHz gilt:

Die Ausgangsspannung des Regelverstärkers soll bei einem Ausgangspegel von 13dBm (19 dBm mit Option SMY-B40) 7.5V betragen. Bei elektronischer Pegelabsenkung auf 7dBm (13 dBm mit Option SMY-B40) soll diese Spannung auf 5.4V absinken und bei weiterer elektronischer Pegelabsenkung bis zu -6dBm (0 dBm mit Option SMY-B40) konstant auf 5.4V bleiben.

- Den Geräteausgang RF 50Ω mit 50Ω abschließen.
 - LEVEL 13 dBm (19 dBm mit Option SMY-B40) einstellen und
 - Spezialfunktion 1 (unterbrechungsfreie Pegeleinstellung) einschalten.
- Über die Spezialfunktion 106 kann die Ausgangsspannung des Regelverstärkers gemessen werden.

7.4.3 Prüfen der LEVEL PRESET-Steuerspannung

- Den Geräteausgang RF 50Ω mit 50Ω abschließen.
 - LEVEL 13 dBm (19 dBm mit Option SMY-B40) einstellen
 - Spezialfunktion 1 (unterbrechungsfreie Pegeleinstellung) einschalten.
- Über die Spezialfunktion 108 kann die LEVEL PRESET-Spannung gemessen werden.
Die Spannung ist abhängig von der RF-Frequenz und vom RF-Pegel. Der Rechner sendet die berechneten Werte in den LEVEL PRESET-D/A-Wandler.

Typische Spannungswerte sind in folgender Tabelle dargestellt:

RF-Frequenz	SMY02 ohne Option SMY-B40				SMY02 mit Option SMY-B40			
	13 dBm	7 dBm	0 dBm	-6 dBm	19 dBm	13 dBm	6 dBm	0 dBm
25 MHz	1.4 V	1.4 V	1.0 V	0.8 V	1.4 V	1.4 V	1.0 V	0.8 V
100 MHz	1.6 V	1.6 V	1.2 V	0.8 V	1.6 V	1.6 V	1.2 V	0.8 V
300 MHz	1.4 V	1.4 V	1.0 V	0.8 V	1.4 V	1.4 V	1.0 V	0.8 V
500 MHz	1.3 V	1.3 V	1.0 V	0.8 V	1.3 V	1.3 V	1.0 V	0.8 V
750 MHz	2.0 V	2.0 V	1.4 V	1.0 V	2.0 V	2.0 V	1.4 V	1.0 V
800 MHz	1.6 V	1.6 V	1.2 V	1.0 V	1.6 V	1.6 V	1.2 V	1.0 V
1040 MHz	2.2 V	2.2 V	1.5 V	1.2 V	2.2 V	2.2 V	1.5 V	1.2 V
1041 MHz	1.0 V	1.0 V	0.9 V	0.8 V	1.0 V	1.0 V	0.9 V	0.8 V
1200 MHz	1.2 V	1.2 V	1.0 V	0.9 V	1.2 V	1.2 V	1.0 V	0.9 V
1400 MHz	1.3 V	1.3 V	1.1 V	1.0 V	1.3 V	1.3 V	1.1 V	1.0 V
1600 MHz	1.4 V	1.4 V	1.1 V	1.0 V	1.4 V	1.4 V	1.1 V	1.0 V
1800 MHz	1.8 V	1.8 V	1.5 V	1.4 V	1.8 V	1.8 V	1.5 V	1.4 V
2000 MHz	2.1 V	2.1 V	1.6 V	1.5 V	2.1 V	2.1 V	1.6 V	1.5 V
2080 MHz	2.4 V	2.4 V	1.8 V	1.6 V	2.4 V	2.4 V	1.8 V	1.6 V

7.4.4 Prüfen der Arbeitspunkte der Verstärkerstufen

Prüfpunkt	Sollspannung	Bemerkung
N360/3	5.50 ± 1.1 V	RF AMPLIFIER 2
N410/3	5.50 ± 1.1 V	RF AMPLIFIER 3
V602 Kollektor	8.90 ± 0.3 V	RF AMPLIFIER 4
V612 Kollektor	5.90 ± 0.3 V	IF AMPLIFIER
V671 Kollektor	5.50 ± 1.1 V	RF AMPLIFIER 7
V874 Kollektor	5.20 ± 1.1 V	RF AMPLIFIER 8
V769 Kollektor	5.20 ± 1.1 V	RF AMPLIFIER 9
V801 Kollektor	5.20 ± 1.1 V	RF AMPLIFIER 11
V817 Kollektor	15.9 ± 0.3 V	RF AMPLIFIER 12
V832 Kollektor	15.9 ± 0.3 V	RF AMPLIFIER 13

7.4.5 Prüfen der Ansteuerung der Filterbank

– Prüfen von LPSELECT-0 ... LPSELECT-3 und der Schaltleitungen TP0 ... TP8.

RF-Frequenz	LPSELECT-				Hinweis
	2	1	0		
3 D111/8	D111/11	D111/6	D111/3		
1560.00 MHz	0	0	0	1	Tiefpaß 1, Verdopplerbereich
1040.01 MHz	0	0	1	0	Tiefpaß 2, Verdopplerbereich
780.00 MHz	0	0	0	1	Tiefpaß 1
520.00 MHz	0	0	1	0	Tiefpaß 2
390.00 MHz	0	0	1	1	Tiefpaß 3
260.00 MHz	0	1	0	0	Tiefpaß 4
195.00 MHz	0	1	0	1	Tiefpaß 5
130.00 MHz	0	1	1	0	Tiefpaß 6
97.50 MHz	0	1	1	1	Tiefpaß 7
65.00 MHz	1	0	0	0	Tiefpaß 8
64.00 MHz	0	0	1	0	Tiefpaß 2, Mischerbereich

Bei Geräteausgangsfrequenzen $65 \text{ MHz} \leq f_{\text{RF}} \leq 1040 \text{ MHz}$ wird von der Baugruppe Synthese die Ausgangsfrequenz geliefert.

Bei Geräteausgangsfrequenzen $f_{\text{RF}} > 1040 \text{ MHz}$ wird von der Baugruppe Synthese die halbe Ausgangsfrequenz geliefert ($520 \text{ MHz} < f_{\text{SYN}} \leq 1040 \text{ MHz}$).

7.4.6 Prüfen des RF-Pegels nach der Filterbank

- Den Geräteausgang RF 50Ω mit 50Ω abschließen.
- Einstellung: RF LEVEL 13 dBm (19 dBm mit Option SMY-B40)
- _ Über die Spezialfunktion 104 kann die gleichgerichtete RF-Spannung gemessen werden.

Typische Spannungswerte sind in folgender Tabelle dargestellt:

RF-Frequenz	Diagnosespannung
10 MHz	0.8 V
100 MHz	0.6 V
200 MHz	0.9 V
400 MHz	1.1 V
600 MHz	1.2 V
800 MHz	0.8 V
1000 MHz	1.1 V
1040 MHz	0.9 V
1041 MHz	1.5 V
1200 MHz	1.1 V
1400 MHz	1.0 V
1600 MHz	1.0 V
1800 MHz	1.0 V
2000 MHz	1.8 V
2080 MHz	1.9 V

7.4.7 Prüfen der Ansteuerung der Bandpaßschalter

_ Prüfen von BP1ON, BP2ON und BP3ON.

RF-Frequenz	BP1ON	BP2ON	BP3ON	Hinweis
D112/3	D112/6	D112/11		
1040.00 MHz	0	0	0	Bandpässe ausgeschaltet
1040.01 MHz	1	0	0	Bandpass 1 ein
1310.40 MHz	0	1	0	Bandpass 2 ein
1651.10 MHz	0	0	1	Bandpass 3 ein

7.4.8 Abgleich der ZF-Verstärkung

- Spektrumanalysator an Geräteausgang RF 50 Ω anschließen
- Einstellung: RF 10 MHz
LEVEL 13 dBm (19 dBm mit Option SMY-B40)
- _ RF-Signal messen, RF-Pegel merken
- _ RF-Frequenz um 1 Hz erniedrigen
- _ Mit Pot R645 den RF-Pegel auf den gleichen Wert einstellen
- _ Nach dem Abgleich sollte die Kalibrierroutine LEVEL PRESET aufgerufen werden.

7.4.9 Abgleich der ZF-Detektor-Linearität

- Einstellung: RF 9.9 MHz
LEVEL 5.1 dBm (11.1 dBm mit Option SMY-B40)
- _ Ausgangspegel am RF-Ausgang des Gerätes messen und merken (= Referenzpegel)
- Einstellung: Spezialfunktion 1 einschalten
(unterbrechungsfreie Pegeleinstellung)
LEVEL -14.9 dBm (-8.9 dBm mit Option SMY-B40)
- _ Mit POT R619 so abgleichen, daß der gemessene Pegel 20 dB unter dem zuvor gemessenen Referenzpegel liegt. Abgleich einmal wiederholen, da sich der Referenzwert mit R619 geringfügig ändert; die Genauigkeit der 20dB-Absenkung soll nach dem Abgleich ± 0.1 dB erreichen.

7.4.10 Abgleich der Detektor-Linearität am Ausgang FOPU

- Dieser Abgleich darf nur dann durchgeführt werden, wenn **keine** Option SMY-B40 eingebaut ist!
- Einstellung: RF 100 MHz
LEVEL 13 dBm
- _ Ausgangspegel am RF-Ausgang des Gerätes messen und merken (= Referenzpegel)
- Einstellung: Spezialfunktion 1 einschalten
(unterbrechungsfreie Pegeleinstellung)
LEVEL -7 dBm
- _ Mit POT R851 so abgleichen, daß der gemessene Pegel 20 dB unter dem zuvor gemessenen Referenzpegel liegt. Abgleich einmal wiederholen, da sich der Referenzwert mit R851 ändert; die Genauigkeit der 20dB-Absenkung soll nach dem Abgleich ± 0.1 dB erreichen.

7.4.11 Abgleich des AM-Modulationsgrades

- Einstellung: PRESET
 LEVEL 7 dBm (+13 dBm mit Option SMY-B40)
 AM EXT DC 100%
 Spezialfunktion 105 einschalten
 (Führungswert der Pegelregelung)
- Eine Gleichspannung $U = -1.000$ V an AM EXT anlegen.
_ Mit POT R280 auf 0 V abgleichen.

7.5 Zerlegung und Zusammenbau

Oberen Gerätedeckel entfernen. Die Baugruppe ist links und rechts an der Auflage festgeschraubt. Nach dem Entfernen dieser Schrauben und dem Lösen der Koax-Verbindungen an X224, X225 und X226 kann die Baugruppe aus ihrem Steckplatz entnommen werden.

7.6 Endprüfung

7.6.1 Prüfen des maximalen Ausgangspegels

- Einstellung: LEVEL 19 dBm (25 dBm mit Option SMY-B40)
- An X226 FOPU einen Leistungsmesser anschließen, dabei muß ggf. ein geeignetes RF-Dämpfungsglied vorgeschaltet werden, um den Meßkopf nicht zu überlasten.
- RF-Frequenz von 5kHz bis 2080 MHz variieren.
Der RF-Pegel muß > 15 dBm (20 dBm mit Option SMY-B40) bleiben.

Typische Pegelwerte sind in folgender Tabelle dargestellt:

	SMY02 ohne Option SMY-B40	SMY02 mit Option SMY-B40
RF-Frequenz	Ausgangspegel	Ausgangspegel
10 MHz	19 dBm	21 dBm
200 MHz	19 dBm	25 dBm
400 MHz	19 dBm	24 dBm
600 MHz	20 dBm	25 dBm
800 MHz	18 dBm	26 dBm
1000 MHz	17 dBm	25 dBm
1200 MHz	19 dBm	24 dBm
1400 MHz	18 dBm	24 dBm
1600 MHz	17 dBm	24 dBm
1800 MHz	16 dBm	23 dBm
2000 MHz	16 dBm	24 dBm
2080 MHz	16 dBm	24 dBm

7.6.2 Prüfen des Oberwellenabstandes

- Gerät ohne Option SMY-B40:
- Einstellung: LEVEL 10 dBm

_ An X226 FOPU einen Spektrumanalysator anschließen.
 _ Der Pegel der Harmonischen muß < -30 dBc sein.

- Gerät mit Option SMY-B40:
- Einstellung: LEVEL 16 dBm
 Spezial 21 (ALC aus)

Da für die Messung die Verbindung von FOPU zum Powermodul aufgetrennt wird, muß die Pegelregelung auf den Sample-and-Hold-Betrieb geschaltet werden. Vor jeder Änderung der Geräteeinstellung muß diese Verbindung wieder geschlossen werden!

_ Meßfrequenz einstellen.
 _ An X226 FOPU einen Spektrumanalysator anschließen.
 _ Der Pegel der Harmonischen muß <-25 dBc sein.

Typische Meßwerte sind in folgender Tabelle dargestellt:

RF-Frequenz	SMY02 ohne Option SMY-B40		SMY02 mit Option SMY-B40	
	2*frf	3*frf	2*frf	3*frf
1 MHz	-45 dBc	-40 dBc	-45 dBc	-48 dBc
10 MHz	-50 dBc	-45 dBc	-48 dBc	-48 dBc
200 MHz	-50 dBc	-45 dBc	-40 dBc	-50 dBc
400 MHz	-45 dBc	-40 dBc	-35 dBc	-45 dBc
600 MHz	-35 dBc	-40 dBc	-35 dBc	-50 dBc
800 MHz	-35 dBc	-40 dBc	-35 dBc	-50 dBc
1000 MHz	-35 dBc	-50 dBc	-32 dBc	-50 dBc
1200 MHz	-35 dBc	-50 dBc	-32 dBc	-50 dBc
1400 MHz	-40 dBc	-45 dBc	-32 dBc	-50 dBc
1600 MHz	-45 dBc	-45 dBc	-32 dBc	-50 dBc
1800 MHz	-45 dBc	-45 dBc	-32 dBc	-50 dBc
2000 MHz	-35 dBc	-50 dBc	-35 dBc	-50 dBc
2080 MHz	-45 dBc	-50 dBc	-45 dBc	-50 dBc

7.6.3 Prüfen des Nebenwellenabstandes

- Gerät ohne Option SMY-B40:
- Einstellung: RF 63 MHz
 LEVEL 13 dBm

_ An X226 FOPU einen Spektrumanalysator anschließen.
 _ Nebenwellen bei folgenden Frequenzen prüfen:
 703 MHz, 640 MHz, 136 MHz, 73 MHz, 10 MHz
 Der Pegel der Nebenwellen muß < -70 dBc sein (typ. < -100 dBc).

- Gerät mit Option SMY-B40:
- Einstellung: LEVEL 19 dBm
 Spezial 21 (ALC aus)

Da für die Messung die Verbindung von FOPU zum Powermodul aufgetrennt wird, muß die Pegelregelung auf den Sample-and-Hold-Betrieb geschaltet werden. Vor jeder Änderung der Geräteeinstellung muß diese Verbindung wieder geschlossen werden!

_ Nebenwellen bei folgenden Frequenzen prüfen:
703 MHz, 640 MHz, 136 MHz, 73 MHz, 10 MHz

_ RF-Frequenz einstellen.
_ An X226 FOPU einen Spektrumanalysator anschließen.
Der Pegel der Nebenwellen muß < -70 dBc sein (typ. < -100 dBc).

7.6.4 Prüfen des Subharmonischenabstandes

- Gerät ohne Option SMY-B40:
- Einstellung: LEVEL 13 dBm
- _ An X226 FOPU einen Spektrumanalysator anschließen.
RF-Frequenz am SMY einstellen und bei f_{SUB1} und f_{SUB2} (siehe Tabelle) den Pegel der Subharmonischen messen. Er muß < -40 dBc sein.

- Gerät mit Option SMY-B40:
- Einstellung: LEVEL 19 dBm
 Spezial 21 (ALC aus)

Da für die Messung die Verbindung von FOPU zum Powermodul aufgetrennt wird, muß die Pegelregelung auf den Sample-and-Hold-Betrieb geschaltet werden. Vor jeder Änderung der Geräteeinstellung muß diese Verbindung wieder geschlossen werden!

_ RF-Frequenz einstellen.
_ An X226 FOPU einen Spektrumanalysator anschließen.
Bei f_{SUB1} und f_{SUB2} (siehe Tabelle) den Pegel der Subharmonischen messen. Er muß < -40 dBc sein.

RF-Frequenz	fsub1	fsub2
1040.01 MHz	520.005 MHz	1560.015 MHz
1310.39 MHz	655.195 MHz	1965.585 MHz
1310.40 MHz	655.200 MHz	1965.600 MHz
1559.99 MHz	779.995 MHz	2339.985 MHz
1560.00 MHz	780.000 MHz	2340.000 MHz
1651.09 MHz	825.545 MHz	2476.635 MHz
1651.10 MHz	825.550 MHz	2476.650 MHz
2080.00 MHz	1040.000 MHz	3120.000 MHz

Pin	Name	Ein/Ausgang	Herkunft/Ziel	Wertebereich	Signalbeschreibung
X2A.01	BLANK	Eingang	Rückwanne	HCMOS-Pegel	RF-Pegelaustastung
X2A.05	DETEXT	Eingang	Pmod	0 ... 10 V	Detektorspg. Option SMY-B40
X2A.07	AMMOD	Eingang	CPU X3.34	-1 V bis 1 V	AM-Signal
X2A.12	SERCLK	Eingang	CPU X3.2	HCMOS-Pegel	Clock
X2A.14	SERDAT	Eingang	CPU X3.4	HCMOS-Pegel	serielle Daten
X2A.15	AT1STB	Eingang	CPU X3.16	HCMOS-Pegel	Strobe 1
X2A.17	HFINT	Ausgang	CPU X3.20	HCMOS-Pegel	Interrupt Pegelregelung
X2A.19	DIAG-5V	Ausgang	CPU X3.6	-5 V...5 V	Diagnose
X2A.22	VA24-P	Eingang	Netzteil X21.22	23.4 V...24.6 V	Versorgungsspannung analog
X2A.24	VA15-P	Eingang	Netzteil X21.13	14.80 V...15.75 V	Versorgungsspannung analog
X2A.25					
X2A.28	VA-5P	Eingang	Netzteil X21.5	5.10V..5.25V	Versorgungsspannung analog
X2A.30	VA15-N	Eingang	Netzteil X21.20	-15.75V..-14.85V	Versorgungsspannung analog
X224	FSYN	Eingang	YSYN X124	6 - 12 dBm	65 - 1040 MHz
X225	REF640	Eingang	YSYN X125	9 - 12 dBm	640 MHz
X226	FOPU	Ausgang	Eichleitung X2	-6...20 dBm	5 kHz - 2.08 GHz

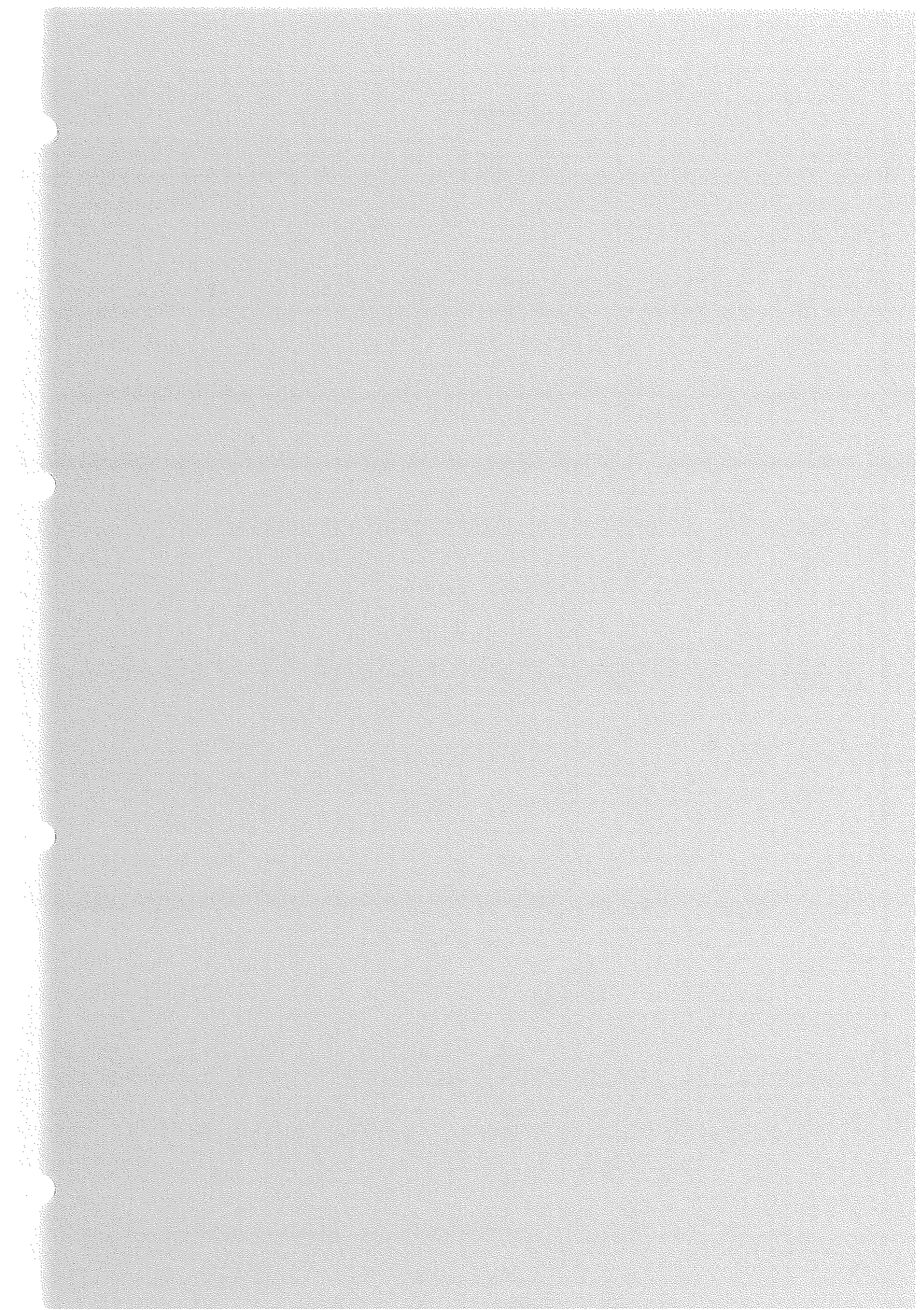

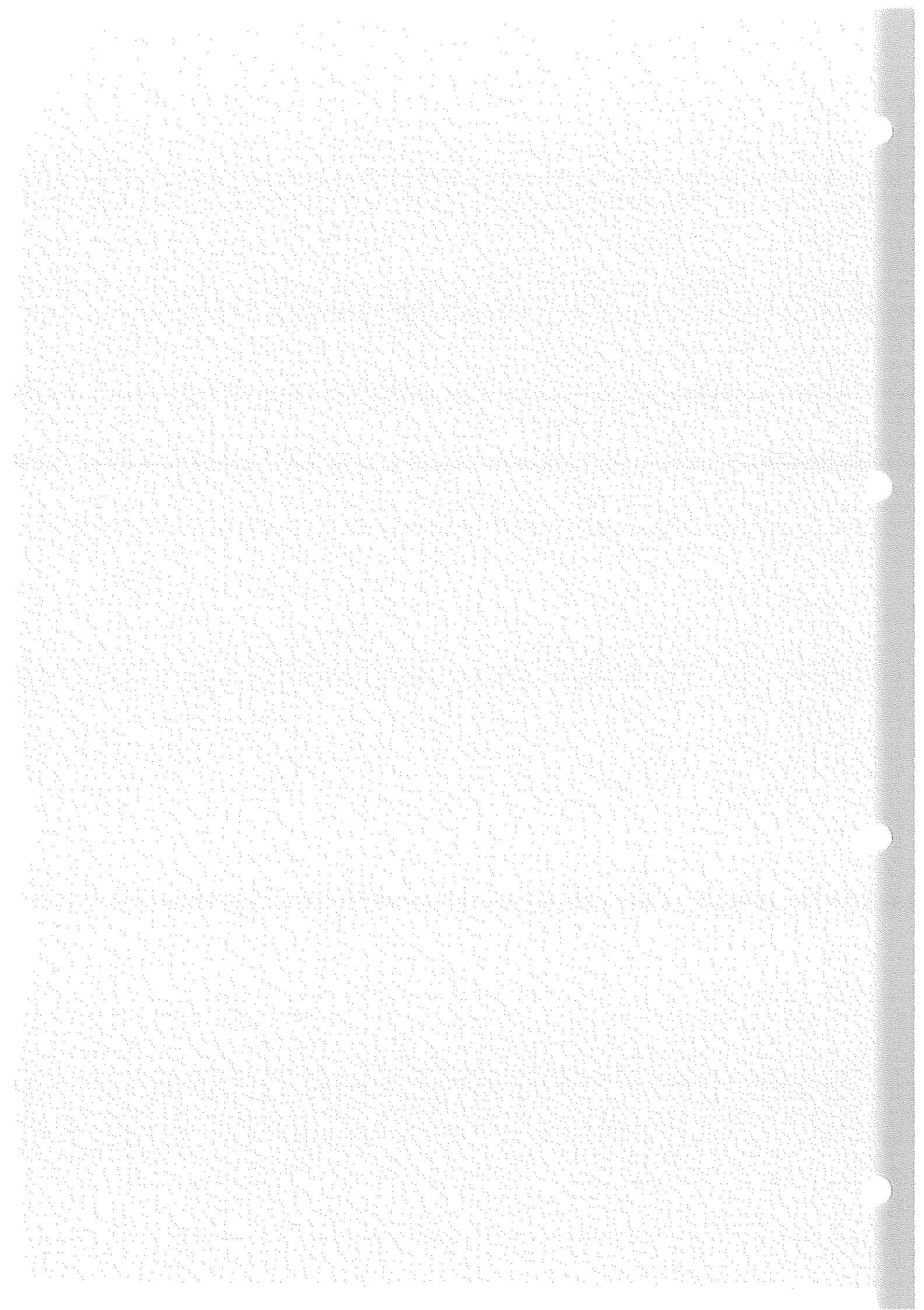



ROHDE & SCHWARZ

SERVICE INSTRUCTIONS

Output Module 2.08 GHz

1062.7005.01

Contents

7 Testing and Repair of the Module.....	5
7.1 Function Description.....	5
7.1.1 RF Signal Processing.....	5
7.1.2 Mixer with LO, RF and IF Filters.....	6
7.1.3 Output Amplifier.....	6
7.1.4 AM Signal Path a. Nominal Value of RF Level.....	6
7.1.5 RF Level Control.....	6
7.1.6 Serial Interface.....	7
7.1.7 Circuit for Diagnostics Selection.....	7
7.2 Test Instrument and Utilities.....	7
7.3 Troubleshooting.....	8
7.3.1 Errors Occurring Only in the Range $f_{RF} < 10$ MHz.....	8
7.3.2 Errors Occurring Only in the Range $f_{RF} < 65$ MHz.....	8
7.3.3 Errors in the Range $5 \text{ kHz} \leq f_{RF} \leq 1040$ MHz.....	8
7.3.4 Errors in the Range $1040 \text{ MHz} \leq f_{RF} \leq 2080$ MHz.....	9
7.3.5 Spectral Purity, $\Delta f < 10$ MHz from the Carrier..	10
7.4 Testing and Adjustment.....	10
7.4.1 Testing Data Transmission.....	10
7.4.2 Testing the Output Voltage of the Control Amplifier..	10
7.4.3 Testing the LEVEL PRESET Control Voltage.....	11
7.4.4 Testing the Operating Points of Amplifier Stages....	11
7.4.5 Testing the Harmonic Filter Control.....	12
7.4.6 Testing the RF Level at the Harmonic Filter Output..	12
7.4.7 Testing Control of the Bandpass Filter Switches.....	13
7.4.8 IF Amplification Adjustment.....	13
7.4.9 IF Detector Linearity Adjustment.....	13
7.4.10 Detector Linearity Adjustment at the Output FOPU...	13
7.4.11 AM Depth Adjustment.....	14
7.5 Disassembly and Assembly.....	14
7.6 Final Test.....	15
7.6.1 Maximum Output Level Check.....	15
7.6.2 Harmonics Suppression Check.....	15
7.6.3 Nonharmonics Suppression Check.....	16
7.6.4 Subharmonics Suppression Check.....	17
7.7 External Interfaces.....	18

Parts list
List of coordinates
Circuit diagram
Component layout diagram

In instruments without fitted option SMY-B40, this module has the variant VAR 02.

In instruments with fitted option SMY-B40, this module has the variant VAR 03.

7.1 Function Description

The Output Module 2.08 GHz is provided with the RF signal (6 dBm to 12 dBm) in the frequency range $65 \text{ MHz} \leq f_{\text{SYN}} \leq 1040 \text{ MHz}$ by the synthesis module via the input FSYN. This RF signal is passed via an amplitude modulator and an amplitude control element to switchable harmonic filters. The output frequency range of $5 \text{ kHz} \leq f_{\text{RF}} < 65 \text{ MHz}$ is realized in the signal path via the changeover switches SWITCHB and SWITCHD by means of downconversion with a 640 MHz LO.

The doubler path can be switched on via the changeover switches SWITCHA and SWITCHC to realize the output frequency range $1040 \text{ MHz} < f_{\text{RF}} \leq 2080 \text{ MHz}$.

The module consists of the following function units:

- an AM modulator for level control and amplitude modulation in the frequency range $5 \text{ kHz} \leq f_{\text{RF}} \leq 1040 \text{ MHz}$,
- an AM modulator for level presetting (LEVEL PRESET),
- switchable harmonic filters,
- a mixer with LO, RF and IF filters,
- a level detector in the RF path preceding the mixer,
- a frequency doubler,
- an AM modulator for level control and amplitude modulation in the frequency range $1040 \text{ MHz} < f_{\text{RF}} \leq 2080 \text{ MHz}$,
- switchable bandpasses for suppression of subharmonics,
- an output amplifier,
- a level detector at the output FOPU,
- a signal path for setting the nominal value of the RF level and the amplitude-modulation depth,
- the RF-level control,
- a serial interface and
- a circuit for diagnostics selection.

Further information on levels apply for an instrument output level of +13 dBm (+19 dBm with option SMY-B40).

7.1.1 RF Signal Processing

The input X224 FSYN is followed by an attenuator for temperature compensation. The attenuator is followed by the AM MODULATOR.

It is used as control element for level control in the range $f_{\text{RF}} \leq 1.04 \text{ GHz}$.

The RF signal is amplified by RF AMPLIFIER 1 and RF AMPLIFIER 2 and passed to the PIN modulator LEVEL PRESET. This modulator is set by means of stored calibration data via the D/A converter such that the control element for level control can be openominal in an optimum operating point (cf. operating manual "Calibrating LEVEL PRESET").

The RF signal is amplified by the RF AMPLIFIER 3 and routed to switchable HARMONIC FILTERS. These filters are switched on by the controller depending on the input frequency at X224 FSYN. Similar to the lowpasses TP4 to TP8, the lowpasses TP0 and TP3 are cascaded. Filters which have a higher cutoff frequency than the cutoff frequency of the lowpass selected remain switched on. In "normal operation", the RF signal passes via the PIN switch SWITCHD (OFF) and the GaAs changeover switch SWITCHB (OFF) to the output amplifier.

In "mixer operation", the RF signal is passed via the PIN switch SWITCHD (ON) and the RF AMPLIFIER 4 to the detector preceding the mixer.

In "doubler operation", the RF signal is switched via the GaAs switch SWITCHA (ON) to the doubler. The output signal of the latter is passed via the DOUBLER MODULATOR to switchable bandpass filters and via the GaAs switch SWITCHC (ON) to the output amplifier.

7.1.2 Mixer with LO, RF and IF Filters

The RF signal supplied by the detector preceding the mixer is switched via the RF lowpass and an attenuator to the RF input of the mixer for level adjustment (level approx. -5 to -10 dBm). The signal of REF640 passes via a lowpass to the LO input of the mixer. The IF signal reaches the RF switch SWITCHB (ON) preceding the output amplifier via the IF amplifier and the IF lowpass ($5 \text{ kHz} \leq f_{ZF} < 65 \text{ MHz}$, level approx. 0 dBm).

7.1.3 Output Amplifier

The three-stage linear broadband amplifier amplifies the input signal by approx. 19 dB. The operating points of the stages RF AMPLIFIER 12 and RF AMPLIFIER 13 are controlled.

7.1.4 AM Signal Path a. Nominal Value of RF Level

The signal of the AMMOD line is passed to the D/A converter for setting of the modulation depth and is then applied to the D/A converter RFLEV for setting of the RF level.

7.1.5 RF Level Control

For instruments without option SMY-B40, the level detector at the output X226 FOPU is used with instrument frequencies $f_{RF} \geq 10 \text{ MHz}$. The RF level at the diode is approx. +19 dBm. The linearization circuit allows for a dynamic range of approx. 30 dB with good linearity (important for low distortion).

For instruments with option SMY-B40, the detector on the option SMY-B40 is used for level control at instrument frequencies $\geq 10 \text{ MHz}$. Its output voltage is applied to the motherboard via the cable W125 and then fed into the input X2.A5 DETEXT of this module.

The level detector in the RF path preceding the mixer is used with instrument frequencies $f_{RF} < 10$ MHz instead of the detector at the output X226 FOPU. The RF level at the diode is approx. +15 dBm.

The level is controlled via the PI regulator N335. The reference value is supplied by the D/A converter RFLEV and compared to the actual value of one of the three detectors (VDET, DETEXT or VDETMIX) according to the frequency range. The output voltage of the PI regulator adjusts the control element:

the AM MODULATOR operates in the range $f_{RF} \leq 1040$ MHz;
the DOUBLER MODULATOR operates in the range $f_{RF} > 1040$ MHz;
additionally, the control voltage of the AM MODULATOR is fixed to approx. 14 V by the control signal MODUFIX, in order to obtain minimum attenuation.

The 3-dB bandwidth of the control loop can be reduced by AMSLOW from approx. 300 kHz to approx. 50 kHz (see special function 13).

Activating of KLEMM-N by the processor sets the AM modulator to maximum attenuation, which is used, e.g., for frequency changes in order to avoid level spikes.

7.1.6 Serial Interface

The incoming data are clocked into the shift registers and the D/A converters LEVEL PRESET, RFLEV and AM.

7.1.7 Circuit for Diagnostics Selection

One of eight dc voltages can be applied to the diagnostic line via the diagnostic multiplexer. The voltage can be displayed on the instrument.

Special function	Nominal voltage range	Remark
101	0.00 V to 5 V	RF level before passing Doubler Modulator
102	0.00 V to 6 V	Detector voltage output FOPU
103	0.00 V to 6 V	Detector voltage mixer
104	0.01 V to 3 V	RF level after passing the filter bank
105	-6.00 V to 0 V	Reference value of level control
106	-1.00 V to 10 V	Output voltage of control amplifier
107	-1.00 V to 10 V	Control voltage of the AM modulator
108	0.50 V to 13 V	Control voltage of the LEVEL PRESET element

7.2 Test Instrument and Utilities

- Spectrum analyzer (e.g., FSBS)
- Oscilloscope (e.g., BOL)
- DC voltmeter (multimeter, e.g., UDL33)
- Network analyzer (e.g., ZVR)
- RF power meter (e.g. NRVD with sensor NRV-Z51)
- 10-dB N-attenuator pad (e.g. DNF)

7.3 Troubleshooting

Prior to opening the instrument, it is useful to first start the calibration routine LEVEL PRESET and localize possible error sources using the diagnostic voltages.

7.3.1 Errors Occurring Only in the Range $f_{RF} < 10$ MHz

- incorrect level at X226** Either the detector in the mixed range supplies an incorrect voltage or the PI regulator is not controlled correctly.
Check voltage VDETMIX using special function 103.
- bad AM distortion** Check the linearization circuit of the detector.

7.3.2 Errors Occurring Only in the Range $f_{RF} < 65$ MHz

- Incorrect RF level at X226** Check input REF640, IF amplifier, RF amplifier 4 and control of SBDON-P and SBDON-N of the changeover switches.
- Harmonics too high** Check IF amplifier, IF lowpass and RF switch SWITCHB.
- Spurious signals too high** The mixer is either faulty or its input level is too high (nominal level at the mixer RF input < -5 dBm). Check IF amplifier, IF lowpass and RF switch SWITCHB and the RF lowpass.

7.3.3 Errors in the Range $5 \text{ kHz} \leq f_{RF} \leq 1040$ MHz

- No RF level at X226** The control voltage of the AM modulator must be > 12 V, otherwise, the level control does not work correctly or the reference value of RFLEV D/A converter is incorrect. Check level at the output of harmonic filters (special function 104). Check the RF signal path using a spectrum analyzer with RF probe providing dc isolation (the gain of the amplifier stages is approx. 7 dB)
- Harmonics too high** Check harmonic filters and subsequent RF amplifiers, check operating points of the output amplifier.

Incidental phase modulation with AM too high Check the control voltage of the AM modulator. Perform LEVEL PRESET calibration.

AM distortion too high Test and adjust detector and linearization circuit, check AMSLOW control.

7.3.4 Errors in the Range $1040 \text{ MHz} \leq f_{\text{RF}} \leq 2080 \text{ MHz}$

No RF level at X226 The control voltage of the AM modulator must be $> 12 \text{ V}$, otherwise, the level control does not work correctly or the reference value of RFLEV D/A converter is incorrect. Check level at the output of harmonic filters (special function 104) and level preceding the Doubler Modulator (special function 101). Check changeover switches SwitchA and SwitchC prior and subsequent to the bandpass filters. Check the RF signal path using a spectrum analyzer with RF probe providing dc isolation (the gain of the amplifier stages is approx. 7 dB)

Harmonics too high Check harmonic filters and subsequent RF amplifiers, check switchable bandpass filters and the changeover switches SWITCHA and SWITCHC, check operating point of the DOUBLER MODULATOR and those of the output amplifier.

Subharmonics too high Check switchable bandpass filters and the changeover switches SWITCHA and SWITCHC, check operating point of the DOUBLER MODULATOR, check LEVEL PRESET voltage, perform LEVEL PRESET calibration (special function 45).

Incidental phase modulation with AM too high Check the control voltage of the AM modulator. Perform LEVEL PRESET calibration.

AM distortion too high Test and adjust detector and linearization circuit, check AMSLOW control.

7.3.5 Spectral Purity, $\Delta f < 10$ MHz from the Carrier

Spurious signals at approx. 1 MHz from carrier ALC loop oscillates; check detector and linearization circuit. Perform LEVEL PRESET calibration.

7.4 Testing and Adjustment

Hints: Ground via-holes have been fitted next to the coupling capacitors or resistors. A coaxial cable can be soldered in at such a location and a test instrument (e.g., a network or spectrum analyzer) can be connected via a coupling capacitor or an external dc isolation. Therefore, the coaxial cable is routed through the hole, the external conductor is soldered at the via-hole and the inner conductor at the desired location.

7.4.1 Testing Data Transmission

The test is performed with the instrument settings listed in the table.

- Test the voltages at D120:
"1" = +5 V, "0" = 0 V

RF frequency	D120/14	D120/6	Remark
RF 1MHz	0	1	DETMIXON
RF 10MHz	1	0	DETON

7.4.2 Testing the Output Voltage of the Control Amplifier

The LEVEL PRESET calibration is required for optimum operation of the amplitude modulator. This optimum operating point depends on the RF-frequency range.

The following applies for the frequency range $f_{RF} \leq 1040$ MHz: the nominal output voltage of the control amplifier is 6.3 V for an output level of 13 dBm (19 dBm with option SMY-B40). When the level is reduced electronically to 7 dBm (13 dBm with option SMY-B40), this voltage shall drop to 3.9 V and remain constant at 3.9 V with further electronic reduction down to -6 dBm (0 dBm with option SMY-B40).

The following applies for the frequency range $f_{RF} > 1040$ MHz: the nominal output voltage of the control amplifier is 7.5 V for an output level of 13 dBm (19 dBm with option SMY-B40). When the level is reduced electronically to 7 dBm (13 dBm with option SMY-B40), this voltage shall drop to 5.4V and remain constant at 5.4 V with further electronic reduction down to -6 dBm (0 dBm with option SMY-B40).

- Terminate the instrument output RF 50Ω with 50Ω .
 - Set LEVEL to 13 dBm (19 dBm with option SMY-B40) and
 - switch on special function 1 (non-interrupting level setting))
- The output voltage of the control amplifier can be measured using special function 106.

7.4.3 Testing the LEVEL PRESET Control Voltage

- Terminate the instrument output RF 50Ω with 50Ω.
 - Set LEVEL to 13 dBm (19 dBm with option SMY-B40).
 - Switch on special function 1 (non-interrupting level setting)
- The LEVEL PRESET voltage can be measured using special function 108. The voltage depends on the RF frequency and the RF level. The controller transmits the calculated values to the LEVEL PRESET D/A converter.

Typical voltages are given in the table below:

RF-Frequenz	SMY02 without option SMY-B40				SMY02 with option SMY-B40			
	13 dBm	7 dBm	0 dBm	-6 dBm	19 dBm	13 dBm	6 dBm	0 dBm
25 MHz	1.4 V	1.4 V	1.0 V	0.8 V	1.4 V	1.4 V	1.0 V	0.8 V
100 MHz	1.6 V	1.6 V	1.2 V	0.8 V	1.6 V	1.6 V	1.2 V	0.8 V
300 MHz	1.4 V	1.4 V	1.0 V	0.8 V	1.4 V	1.4 V	1.0 V	0.8 V
500 MHz	1.3 V	1.3 V	1.0 V	0.8 V	1.3 V	1.3 V	1.0 V	0.8 V
750 MHz	2.0 V	2.0 V	1.4 V	1.0 V	2.0 V	2.0 V	1.4 V	1.0 V
800 MHz	1.6 V	1.6 V	1.2 V	1.0 V	1.6 V	1.6 V	1.2 V	1.0 V
1040 MHz	2.2 V	2.2 V	1.5 V	1.2 V	2.2 V	2.2 V	1.5 V	1.2 V
1041 MHz	1.0 V	1.0 V	0.9 V	0.8 V	1.0 V	1.0 V	0.9 V	0.8 V
1200 MHz	1.2 V	1.2 V	1.0 V	0.9 V	1.2 V	1.2 V	1.0 V	0.9 V
1400 MHz	1.3 V	1.3 V	1.1 V	1.0 V	1.3 V	1.3 V	1.1 V	1.0 V
1600 MHz	1.4 V	1.4 V	1.1 V	1.0 V	1.4 V	1.4 V	1.1 V	1.0 V
1800 MHz	1.8 V	1.8 V	1.5 V	1.4 V	1.8 V	1.8 V	1.5 V	1.4 V
2000 MHz	2.1 V	2.1 V	1.6 V	1.5 V	2.1 V	2.1 V	1.6 V	1.5 V
2080 MHz	2.4 V	2.4 V	1.8 V	1.6 V	2.4 V	2.4 V	1.8 V	1.6 V

7.4.4 Testing the Operating Points of Amplifier Stages

Test point	Nominal voltage	Remark
N360/3	5.50 ± 1.1 V	RF AMPLIFIER 2
N410/3	5.50 ± 1.1 V	RF AMPLIFIER 3
V602 Collector	8.90 ± 0.3 V	RF AMPLIFIER 4
V612 Collector	5.90 ± 0.3 V	IF AMPLIFIER
V671 Collector	5.50 ± 1.1 V	RF AMPLIFIER 7
V874 Collector	5.20 ± 1.1 V	RF AMPLIFIER 8
V769 Collector	5.20 ± 1.1 V	RF AMPLIFIER 9
V801 Collector	5.20 ± 1.1 V	RF AMPLIFIER 11
V817 Collector	15.9 ± 0.3 V	RF AMPLIFIER 12
V832 Collector	15.9 ± 0.3 V	RF AMPLIFIER 13

7.4.5 Testing the Harmonic Filter Control

_ Testing LPSELECT-0 ... LPSELECT-3 and the lines TP0 to TP8.

RF frequency	LPSELECT-				Remark
	3	2	1	0	
D111/8	D111/11	D111/6	D111/3		
1560.00 MHz	0	0	0	1	Lowpass 1, Doubler range
1040.01 MHz	0	0	1	0	Lowpass 2, Doubler range
780.00 MHz	0	0	0	1	Lowpass 1
520.00 MHz	0	0	1	0	Lowpass 2
390.00 MHz	0	0	1	1	Lowpass 3
260.00 MHz	0	1	0	0	Lowpass 4
195.00 MHz	0	1	0	1	Lowpass 5
130.00 MHz	0	1	1	0	Lowpass 6
97.50 MHz	0	1	1	1	Lowpass 7
65.00 MHz	1	0	0	0	Lowpass 8
64.00 MHz	0	0	1	0	Lowpass 2, Mixer range

For output frequencies $65 \text{ MHz} \leq f_{\text{RF}} \leq 1040 \text{ MHz}$ on the instrument, the output frequency is supplied by the synthesis module.

For output frequencies $f_{\text{RF}} > 1040 \text{ MHz}$ on the instrument, the synthesis module provides the half output frequency ($520 \text{ MHz} < f_{\text{SYN}} \leq 1040 \text{ MHz}$).

7.4.6 Testing the RF Level at the Harmonic Filter Output

- Terminate the instrument output RF 50Ω with 50Ω .
 - Setting: RF LEVEL 13 dBm (19 dBm with option SMY-B40).
- _ The rectified RF voltage can be measured using special function 104.

Typical voltages are given in the table below:

RF frequency	Diagnostic voltage	
10 MHz	0.8 V	
100 MHz	0.6 V	
200 MHz	0.9 V	
400 MHz	1.1 V	
600 MHz	1.2 V	
800 MHz	0.8 V	
1000 MHz	1.1 V	
1040 MHz	0.9 V	
1041 MHz	1.5 V	
1200 MHz	1.1 V	
1400 MHz	1.0 V	
1600 MHz	1.0 V	
1800 MHz	1.0 V	
2000 MHz	1.8 V	
2080 MHz	1.9 V	

7.4.7 Testing Control of the Bandpass Filter Switches

_ Testing BP1ON, BP2ON and BP3ON.

RF frequency D112/3	BP1ON D112/6	BP2ON D112/11	BP3ON	Remark
1040.00 MHz	0	0	0	Bandpass filters switched off
1040.01 MHz	1	0	0	Bandpass 1 on
1310.40 MHz	0	1	0	Bandpass 2 on
1651.10 MHz	0	0	1	Bandpass 3 on

7.4.8 IF Amplification Adjustment

- Connect a spectrum analyzer to the instrument output RF 50Ω.
- Setting: RF 10 MHz
LEVEL 13 dBm (19 dBm with option SMY-B40)
- Measure RF signal, note RF level
- Decrease RF frequency by 1 Hz
- Adjust the RF level to the same value using the potentiometer R645
- Subsequent to adjustment, call the calibration routine LEVEL PRESET.

7.4.9 IF Detector Linearity Adjustment

- Setting: RF 9.9 MHz
LEVEL +5.1 dBm (11.1 dBm with option SMY-B40)
- Measure and note the output level at the RF output (= ref level)
- Setting: Switch on special function 1
(non-interrupting level setting)
LEVEL -14.9 dBm (-8.9 dBm with option SMY-B40)
- Adjust R619 that the measured level is 20 dB below the previously measured reference level. Repeat adjustment once, since the reference value slightly changes with use of R619; after the adjustment, the accuracy of the 20-dB reduction shall reach ± 0.1 dB.

7.4.10 Detector Linearity Adjustment at the Output FOPU

Note: This adjustment must be carried out if option SMY-B40 is **not** fitted!

- Setting: RF 100 MHz
LEVEL 13 dBm
- Measure and note the output level at the RF output of the instrument (= reference level)

- Setting: Switch on special function 1 (non-interrupting level setting))
 LEVEL -7 dBm
- Adjust R851 that the measured level is 20 dB below the previously measured reference level. Repeat adjustment once, since the reference value changes with use of R851; the accuracy of the 20-dB reduction shall reach ± 0.1 dB.

7.4.11 AM Depth Adjustment

- Setting: PRESET
 LEVEL 7 dBm (+13 dBm with option SMY-B40)
 AM EXT DC 100%
 Switch on special function 105
 (reference value of level control)
- Apply a dc voltage $V = -1.000$ V to AM EXT.
- Adjust to 0 V using POT R280.

7.5 Disassembly and Assembly

Remove upper instrument cover. The module is fixed to the support at the left and right sides. Subsequent to undoing these screws and disconnecting the coaxial connections at X224, X225 and X226, it can be taken out of its slot.

7.6

Final Test

7.6.1 Maximum Output Level Check

- Setting: LEVEL 19 dBm (25 dBm with option SMY-B40)
- Connect a power meter to X226 FOPU.
To prevent the sensor from being overdriven, it might be necessary to insert before a suitable RF-attenuator pad.
- Vary the RF frequency from 5kHz to 2080 MHz.
The RF level must remain > 15 dBm (20 dBm with option SMY-B40).

Typical levels are given in the table below:

	SMY02 without option SMY-B40	SMY02 with option SMY-B40
RF-frequency	output level	output level
10 MHz	19 dBm	21 dBm
200 MHz	19 dBm	25 dBm
400 MHz	19 dBm	24 dBm
600 MHz	20 dBm	25 dBm
800 MHz	18 dBm	26 dBm
1000 MHz	17 dBm	25 dBm
1200 MHz	19 dBm	24 dBm
1400 MHz	18 dBm	24 dBm
1600 MHz	17 dBm	24 dBm
1800 MHz	16 dBm	23 dBm
2000 MHz	16 dBm	24 dBm
2080 MHz	16 dBm	24 dBm

7.6.2 Harmonics Suppression Check

Instrument without option SMY-B40:

- Setting: LEVEL 10 dBm
- Connect a spectrum analyzer to X226 FOPU.
_ The level of the harmonics must be < -30 dBc.

Instrument with option SMY-B40:

- Setting: LEVEL 16 dBm
Special 21 (ALC off)

As the connection from FOPU to the power module is undone for the measurement, the level control must be switched to sample-and-hold operation. This connection must be reestablished before any of the instrument settings are changed.

- Set measurement frequency
- Connect spectrum analyzer to XD226 FOPU
The level of the harmonics must be <-25 dBc.

Typical values are given in the table below:

RF-frequency	SMY02 without option SMY-B40		SMY02 with option SMY-B40	
	2*FRF	3*FRF	2*FRF	3*FRF
1 MHz	-45 dBc	-40 dBc	-45 dBc	-48 dBc
10 MHz	-50 dBc	-45 dBc	-48 dBc	-48 dBc
200 MHz	-50 dBc	-45 dBc	-40 dBc	-50 dBc
400 MHz	-45 dBc	-40 dBc	-35 dBc	-45 dBc
600 MHz	-35 dBc	-40 dBc	-35 dBc	-50 dBc
800 MHz	-35 dBc	-40 dBc	-35 dBc	-50 dBc
1000 MHz	-35 dBc	-50 dBc	-32 dBc	-50 dBc
1200 MHz	-35 dBc	-50 dBc	-32 dBc	-50 dBc
1400 MHz	-40 dBc	-45 dBc	-32 dBc	-50 dBc
1600 MHz	-45 dBc	-45 dBc	-32 dBc	-50 dBc
1800 MHz	-45 dBc	-45 dBc	-32 dBc	-50 dBc
2000 MHz	-35 dBc	-50 dBc	-35 dBc	-50 dBc
2080 MHz	-45 dBc	-50 dBc	-45 dBc	-50 dBc

7.6.3 Nonharmonics Suppression Check

Instrument without option SMY-B40:

- Setting: RF 63 MHz
 LEVEL 13 dBm
 - Connect a spectrum analyzer to X226 FOPU.
 - Test spurious responses with the subsequent frequencies:
703 MHz, 640 MHz, 136 MHz, 73 MHz, 10 MHz
- The level of the spurious signals must be < -70 dBc (typ. < -100 dBc).

Instrument with option SMY-B40:

- Setting: LEVEL 19 dBm
 Special 21 (ALC off)

As the connection from FOPU to the power module is undone for the measurement, the level control must be switched to sample-and-hold operation. This connection must be reestablished before any of the instrument settings are changed.

- Test spurious signals for the following frequencies:
703 MHz, 640 MHz, 136 MHz, 73 MHz, 10 MHz
- Set RF-frequency
- Connect spectrum analyzer to X226 FOPU
The level of the spurious signals must be < -70 dBc (typ. < -100 dBc).

7.6.4 Subharmonics Suppression Check

Instrument without option SMY-B40:
 Setting: LEVEL 13 dBm

- Connect a spectrum analyzer to X226 FOPU.
- Set RF frequency on the SMY and measure the level of the subharmonics with f_{SUB1} and f_{SUB2} (see table below). The level must be < -40 dBc.

Instrument with option SMY-B40:

- Setting: LEVEL 19 dBm
 Special 21 (ALC off)

As the connection from FOPU to the power module is undone for the measurement, the level control must be switched to sample-and-hold operation. This connection must be reestablished before any of the instrument settings are changed.

- Set RF frequency
- Connect a spectrum analyzer to X226 FOPU.
- Measure the level of the subharmonics with f_{SUB1} and f_{SUB2} (see table below). The level must be < -40 dBc.

RF frequency	fsub1	fsub2	
1040.01 MHz	520.005 MHz	1560.015 MHz	
1310.39 MHz	655.195 MHz	1965.585 MHz	
1310.40 MHz	655.200 MHz	1965.600 MHz	
1559.99 MHz	779.995 MHz	2339.985 MHz	
1560.00 MHz	780.000 MHz	2340.000 MHz	
1651.09 MHz	825.545 MHz	2476.635 MHz	
1651.10 MHz	825.550 MHz	2476.650 MHz	
2080.00 MHz	1040.000 MHz	3120.000 MHz	

7.7

External Interfaces

Pin	Name	Input/Output	Origin/Dest.	Specified range	Signal description
X2A.01	BLANK	Input	Rear panel	HCMOS level	RF-level blanking
X2A.05	DETEXT	Input	PMOD	0 to 10 V	Detector voltage option SMY-B40
X2A.07	AMMOD	Input	CPU X3.34	-1 V to 1 V	AM signal
X2A.12	SERCLK	Input	CPU X3.2	HCMOS level	Clock
X2A.14	SERDAT	Input	CPU X3.4	HCMOS level	Serial data
X2A.15	AT1STB	Input	CPU X3.16	HCMOS level	Strobe 1
X2A.17	HFINT	Output	CPU X3.20	HCMOS level	Interrupt level control
X2A.19	DIAG-5V	Output	CPU X3.6	-5V to 5V	Diagnostics
X2A.22	VA24-P	Input	Power X21.22	23.4V to 24.6V	Analog supply voltage
X2A.24	VA15-P	Input	Power X21.13	14.80V to 15.75V	Analog supply voltage
X2A.25					
X2A.28	VA-5P	Input	Power X21.5	5.10V to 5.25V	Analog supply voltage
X2A.30	VA15-N	Input	Power X21.20	-15.75V to -14.85V	Analog supply voltage
X224	FSYN	Input	YSYN X124	6 - 12dBm	65 - 1040 MHz
X225	REF640	Input	YSYN X125	9 - 12 dBm	640 MHz
X226	FOPU	Output	Attenuator X2	-6 to 20 dBm	5 kHz - 2.08 GHz

**Schalteillisten
numerisch geordnet**

**Part lists
in numerical order**

**Listes des pièces détachées
par numéros de référence**

Kennz. Comp. No.	Benennung Designation	Sachnummer Stock No.	Hersteller Manufacturer	Bezeichnung Designation	enthalten in contained in	
	XX VARIANTENERKLAERUNG IDENTIFICATION OF MODELS VAR 02 = GRUNDAUSFUEHRUNG MOD 02 = BASIC_MODEL VAR 03 = SMY12+SMY-B40 UMGERUESTET AUS VAR 02 MOD 03 = SMY12+SMY-B40 CONVERTED O. MOD 02 VAR 04 = SMY44/45 MOD 04 = SMY44/45 VAR 06 = SMY4X MIT OPT. SMY-B40 UMGERUESTET AUS VAR 04 MOD 06 = SMY4X WITH OPT. SMY-B40 CONVERTED O.MODO4					
C12	CC 47NF+-10%50V X7R 1206 CERAMIC CHIP CAPACITOR	CC 0007.5195.00	PHILIPS_CO	2238 581 15645		
C13	CC 1NF+-1% 50V NPO 1206 SMD CERAMIC CAPACITOR NICHT BESTUECKT/NOT FITTED	CC 0007.7398.00	PHILIPS_CO	2222 863 *8102		
C14	CC 100NF+-10%50V X7R 1206 CERAMIC CHIP CAPACITOR	CC 0007.5237.00	PHILIPS_CO	2238 581 15649		
..17	CERAMIC CHIP CAPACITOR					
C20	CE 220UF+-20%10V RM2,5 ELECTROLYTIC CAPACITOR	CE 0008.7927.00	PANASONIC	ECA-1AFG221I		
C21	CE 10UF+-20%35V RD5,5XH6 ELECTROLYTIC CAPACITOR	0803.0667.00	NAT_PANASO	ECE-A1VKS-100		
C22	CE 10UF+-20%35V RD5,5XH6 ELECTROLYTIC CAPACITOR	0803.0667.00	NAT_PANASO	ECE-A1VKS-100		
C132	CC 100NF+-10%50V X7R 1206 CERAMIC CHIP CAPACITOR	CC 0007.5237.00	PHILIPS_CO	2238 581 15649		
C133	CC 100NF+-10%50V X7R 1206 CERAMIC CHIP CAPACITOR	CC 0007.5237.00	PHILIPS_CO	2238 581 15649		
C149	CC 100NF+-10%50V X7R 1206 CERAMIC CHIP CAPACITOR	CC 0007.5237.00	PHILIPS_CO	2238 581 15649		
..154	CERAMIC CHIP CAPACITOR					
C156	CC 100NF+-10%50V X7R 1206 CERAMIC CHIP CAPACITOR	CC 0007.5237.00	PHILIPS_CO	2238 581 15649		
C157	CC 100NF+-10%50V X7R 1206 CERAMIC CHIP CAPACITOR	CC 0007.5237.00	PHILIPS_CO	2238 581 15649		
C158	CC 100NF+-10%50V X7R 1206 CERAMIC CHIP CAPACITOR	CC 0007.5237.00	PHILIPS_CO	2238 581 15649		
..162	CERAMIC CHIP CAPACITOR					
C170	CC 100NF+-10%50V X7R 1206 CERAMIC CHIP CAPACITOR	CC 0007.5237.00	PHILIPS_CO	2238 581 15649		
C207	CE 10UF +-10% 25V 7343 TANTALUM SMD-CAPACITOR	CE 0007.7246.00	SPRAGUE	293D 106 X9 025 D2T		
C208	CC 2,7PF+-0,25 50VNPO1206 CERAMIC CHIP CAPACITOR NUR VAR/ONLY MOD: 02 04	CC 0007.8188.00	MURATA	GRM42-6COG 2R7 C50PT		
C208	CC 2,7PF+-0,25 50VNPO1206 CERAMIC CHIP CAPACITOR NUR VAR/ONLY MOD: 03 06 NICHT BESTUECKT/NOT FITTED	CC 0007.8188.00	MURATA	GRM42-6COG 2R7 C50PT		
C209	CC 22PF+-1%50V NPO 1206 CERAMIC CHIP CAPACITOR	CC 0099.8396.00	MURATA	GRM42-6COG 220F 50PT		
C219	CC 22PF+-1%50V NPO 1206 CERAMIC CHIP CAPACITOR NUR VAR/ONLY MOD: 02 04	CC 0099.8396.00	MURATA	GRM42-6COG 220F 50PT		
C219	CC 33PF+-1%50V NPO 1206 CERAMIC CHIP CAPACITOR NUR VAR/ONLY MOD: 03 06	CC 0099.8780.00	MURATA	GRM42-6COG 330F 50PT		
C220	CC 270PF+-1%50V NPO 1206 CERAMIC CHIP CAPACITOR	CC 0099.8867.00	PHILIPS_CO	2222 863 18271		
C221	CC 8,2PF+-0,25 50VNPO1206 CERAMIC CHIP CAPACITOR NICHT BESTUECKT NOT FITTED	CC 0007.8242.00	MURATA	GRM42-6COG 8R2 C50PT		
C240	CC 22PF+-1%50V NPO 1206 CERAMIC CHIP CAPACITOR	CC 0099.8396.00	MURATA	GRM42-6COG 220F 50PT		
C242	CC 100PF+-1%50V NPO 1206 CERAMIC CHIP CAPACITOR	CC 0099.8415.00	MURATA	GRM42-6COG 101F 50PT		
C244	CC 100NF+-10%50V X7R 1206 CERAMIC CHIP CAPACITOR	CC 0007.5237.00	PHILIPS_CO	2238 581 15649		
C245	CC 100NF+-10%50V X7R 1206 CERAMIC CHIP CAPACITOR	CC 0007.5237.00	PHILIPS_CO	2238 581 15649		
MENP5	413 3PUA	Är	Datum Date	Schalttailliste für Parts list for	Sachnummer Stock No.	Blatt-Nr. Page
	ROHDE & SCHWARZ	28	16.09.97	EE AUSGANGSTEIL 2.08GHZ OUTPUT UNIT 2.08GHZ	1062.7005.01 SA	1+

Für diese Unterlage behalten
wir uns alle Rechte vor.

Kennz. Comp. No.	Benennung Designation	Sachnummer Stock No.	Hersteller Manufacturer	Bezeichnung Designation	enthalten in contained in
C250 ..264	CC 100NF+-10%50V X7R 1206 CERAMIC CHIP CAPACITOR	CC 0007.5237.00	PHILIPS_CO	2238 581 15649	
C275	CC 8,2PF+-0,25 50VNPO1206 CERAMIC CHIP CAPACITOR	CC 0007.8242.00	MURATA	GRM42-6COG 8R2 C5OPT	
C280	CC 22PF+-1%50V NPO 1206 CERAMIC CHIP CAPACITOR	CC 0099.8396.00	MURATA	GRM42-6COG 22OF 50PT	
C300	CC 10PF+-0,25 50VNPO 1206 CERAMIC CHIP CAPACITOR	CC 0099.8480.00	MURATA	GRM42-6COG 100 C5OPT	
C302	CC 82PF+-1%50V NPO 1206 CERAMIC CHIP CAPACITOR	CC 0099.8821.00	MURATA	GRM42-6COG 82OF 50PT	
C303	CC 82PF+-1%50V NPO 1206 CERAMIC CHIP CAPACITOR	CC 0099.8821.00	MURATA	GRM42-6COG 82OF 50PT	
C313	CC 100NF+-10%50V X7R 1206 CERAMIC CHIP CAPACITOR	CC 0007.5237.00	PHILIPS_CO	2238 581 15649	
C315	CC 1NF+-1% 50V NPO 1206 SMD CERAMIC CAPACITOR	CC 0007.7398.00	PHILIPS_CO	2222 863 *8102	
C316	CC 1NF+-1% 50V NPO 1206 SMD CERAMIC CAPACITOR	CC 0007.7398.00	PHILIPS_CO	2222 863 *8102	
C318	CC 100NF+-10%50V X7R 1206 CERAMIC CHIP CAPACITOR	CC 0007.5237.00	PHILIPS_CO	2238 581 15649	
C319	CC 100NF+-10%50V X7R 1206 CERAMIC CHIP CAPACITOR	CC 0007.5237.00	PHILIPS_CO	2238 581 15649	
C325	CC 100PF+-1%50V NPO 1206 CERAMIC CHIP CAPACITOR	CC 0099.8415.00	MURATA	GRM42-6COG 101F 50PT	
C327	CC 1NF+-1% 50V NPO 1206 SMD CERAMIC CAPACITOR	CC 0007.7398.00	PHILIPS_CO	2222 863 *8102	
C328	CC 1NF+-1% 50V NPO 1206 SMD CERAMIC CAPACITOR	CC 0007.7398.00	PHILIPS_CO	2222 863 *8102	
C329	CC 100NF+-10%50V X7R 1206 CERAMIC CHIP CAPACITOR	CC 0007.5237.00	PHILIPS_CO	2238 581 15649	
C330	CC 100NF+-10%50V X7R 1206 CERAMIC CHIP CAPACITOR	CC 0007.5237.00	PHILIPS_CO	2238 581 15649	
C340	CC 100NF+-10%50V X7R 1206 CERAMIC CHIP CAPACITOR	CC 0007.5237.00	PHILIPS_CO	2238 581 15649	
C356	CC 82PF+-1%50V NPO 1206 CERAMIC CHIP CAPACITOR	CC 0099.8821.00	MURATA	GRM42-6COG 82OF 50PT	
C357	CC 82PF+-1%50V NPO 1206 CERAMIC CHIP CAPACITOR	CC 0099.8821.00	MURATA	GRM42-6COG 82OF 50PT	
C359	CC 100NF+-10%50V X7R 1206 CERAMIC CHIP CAPACITOR NICHT BESTUECKT NOT FITTED	CC 0007.5237.00	PHILIPS_CO	2238 581 15649	
C360	CC 220PF+-1%50V NPO 1206 CERAMIC CHIP CAPACITOR	CC 0099.8850.00	PHILIPS_CO	2238 863 18221	
C361	CC 220PF+-1%50V NPO 1206 CERAMIC CHIP CAPACITOR	CC 0099.8850.00	PHILIPS_CO	2238 863 18221	
C362	CC 100NF+-10%50V X7R 1206 CERAMIC CHIP CAPACITOR	CC 0007.5237.00	PHILIPS_CO	2238 581 15649	
C400	CC 100NF+-10%50V X7R 1206 CERAMIC CHIP CAPACITOR	CC 0007.5237.00	PHILIPS_CO	2238 581 15649	
C401	CC 1NF+-1% 50V NPO 1206 SMD CERAMIC CAPACITOR	CC 0007.7398.00	PHILIPS_CO	2222 863 *8102	
C402	CC 1NF+-1% 50V NPO 1206 SMD CERAMIC CAPACITOR	CC 0007.7398.00	PHILIPS_CO	2222 863 *8102	
C404	CC 100NF+-10%50V X7R 1206 CERAMIC CHIP CAPACITOR	CC 0007.5237.00	PHILIPS_CO	2238 581 15649	
C405	CC 100NF+-10%50V X7R 1206 CERAMIC CHIP CAPACITOR	CC 0007.5237.00	PHILIPS_CO	2238 581 15649	
C410	CC 1NF+-1% 50V NPO 1206 SMD CERAMIC CAPACITOR	CC 0007.7398.00	PHILIPS_CO	2222 863 *8102	
C412	CC 220PF+-1%50V NPO 1206 CERAMIC CHIP CAPACITOR	CC 0099.8850.00	PHILIPS_CO	2238 863 18221	
C417	CC 100NF+-10%50V X7R 1206 CERAMIC CHIP CAPACITOR	CC 0007.5237.00	PHILIPS_CO	2238 581 15649	
C440 ..442	CC 100NF+-10%50V X7R 1206 CERAMIC CHIP CAPACITOR	CC 0007.5237.00	PHILIPS_CO	2238 581 15649	
C445	XX ENTHALTEN IN INCLUDED IN IN LEITERPLATTE				
C500	CC 1NF+-1% 50V NPO 1206 SMD CERAMIC CAPACITOR	CC 0007.7398.00	PHILIPS_CO	2222 863 *8102	
C501	CC 100NF+-10%50V X7R 1206 CERAMIC CHIP CAPACITOR	CC 0007.5237.00	PHILIPS_CO	2238 581 15649	
C502	XX ENTHALTEN IN INCLUDED IN IN LEITERPLATTE				
C504	CC 1NF+-1% 50V NPO 1206 SMD CERAMIC CAPACITOR	CC 0007.7398.00	PHILIPS_CO	2222 863 *8102	

Für diese Unterlage behalten wir uns alle Rechte vor.

MENP5	413 3PUA	Äi	Datum Date	Schaltteilliste für Parts list for	Sachnummer Stock No.	Blatt-Nr. Page
	ROHDE & SCHWARZ	28	16.09.97	EE AUSGANGSTEIL 2.08GHZ OUTPUT UNIT 2.08GHZ	1062.7005.01 SA	2+

095.0028-0693

Für diese Unterlage behalten wir uns alle Rechte vor.

Kannz. Comp. No.	Benennung Designation	Sachnummer Stock No.	Hersteller Manufacturer	Bezeichnung Designation	enthalten in contained in
C505	CC 3,3PF+-0,25 50VNP01206 CERAMIC CHIP CAPACITOR	CC 0007.8194.00	MURATA	GRM42-6COG 3R3 C50PT	
C506	CC 2,7PF+-0,25 50VNP01206 CERAMIC CHIP CAPACITOR	CC 0007.8188.00	MURATA	GRM42-6COG 2R7 C50PT	
C507	CC 2,7PF+-0,25 50VNP01206 CERAMIC CHIP CAPACITOR	CC 0007.8188.00	MURATA	GRM42-6COG 2R7 C50PT	
C509	CC 1NF+-1% 50V NPO 1206 SMD CERAMIC CAPACITOR	CC 0007.7398.00	PHILIPS_CO	2222 863 *8102	
C510	CC 3,9PF+-0,25 50VNP01206 CERAMIC CHIP CAPACITOR	CC 0007.8207.00	MURATA	GRM42-6COG 3R9 C50PT	
C511	CC 3,3PF+-0,25 50VNP01206 CERAMIC CHIP CAPACITOR	CC 0007.8194.00	MURATA	GRM42-6COG 3R3 C50PT	
C512	CC 3,3PF+-0,25 50VNP01206 CERAMIC CHIP CAPACITOR	CC 0007.8194.00	MURATA	GRM42-6COG 3R3 C50PT	
C513	XX ENTHALTEN IN INCLUDED IN				
C514	CC 1NF+-1% 50V NPO 1206 SMD CERAMIC CAPACITOR	CC 0007.7398.00	PHILIPS_CO	2222 863 *8102	
C515	CC 5,6PF+-0,25 50VNP01206 CERAMIC CHIP CAPACITOR	CC 0007.8220.00	MURATA	GRM42-6COG 5R6 C50PT	
C516	CC 4,7PF+-0,25 50VNP01206 CERAMIC CHIP CAPACITOR	CC 0007.8213.00	MURATA	GRM42-6COG 4R7C 50PT	
C517	CC 4,7PF+-0,25 50VNP01206 CERAMIC CHIP CAPACITOR	CC 0007.8213.00	MURATA	GRM42-6COG 4R7C 50PT	
C518	CC 1NF+-1% 50V NPO 1206 SMD CERAMIC CAPACITOR	CC 0007.7398.00	PHILIPS_CO	2222 863 *8102	
C519	CC 1,8PF+-0,25 50VNP01206 CERAMIC CHIP CAPACITOR	CC 0007.8165.00	MURATA	GRM42-6COG 1R8 C50PT	
C520	CC 1,5PF+-0,25 50VNP01206 CERAMIC CHIP CAPACITOR	CC 0007.8159.00	MURATA	GRM42-6COG 1R5 C50PT	
C521	CC 1,5PF+-0,25 50VNP01206 CERAMIC CHIP CAPACITOR	CC 0007.8159.00	MURATA	GRM42-6COG 1R5 C50PT	
C522	XX ENTHALTEN IN INCLUDED IN				
C523	XX ENTHALTEN IN INCLUDED IN				
C524	XX ENTHALTEN IN INCLUDED IN				
C525	XX ENTHALTEN IN INCLUDED IN				
C526	CC 100NF+-10%50V X7R 1206 CERAMIC CHIP CAPACITOR	CC 0007.5237.00	PHILIPS_CO	2238 581 15649	
C527	CC 1NF+-1% 50V NPO 1206 SMD CERAMIC CAPACITOR	CC 0007.7398.00	PHILIPS_CO	2222 863 *8102	
C530	CC 1NF+-1% 50V NPO 1206 SMD CERAMIC CAPACITOR	CC 0007.7398.00	PHILIPS_CO	2222 863 *8102	
C531	CC 1NF+-1% 50V NPO 1206 SMD CERAMIC CAPACITOR	CC 0007.7398.00	PHILIPS_CO	2222 863 *8102	
C532	CC 12PF+-1% 50V NPO 1206 CERAMIC CHIP CAPACITOR	CC 0099.8744.00	MURATA	GRM42-6COG 120 F50PT	
C533	CC 10PF+-0,25 50VNP0 1206 CERAMIC CHIP CAPACITOR	CC 0099.8480.00	MURATA	GRM42-6COG 100 C50PT	
C534	CC 10PF+-0,25 50VNP0 1206 CERAMIC CHIP CAPACITOR	CC 0099.8480.00	MURATA	GRM42-6COG 100 C50PT	
C536	CC 1NF+-1% 50V NPO 1206 SMD CERAMIC CAPACITOR	CC 0007.7398.00	PHILIPS_CO	2222 863 *8102	
C537	CC 18PF+-1% 50V NPO 1206 CERAMIC CHIP CAPACITOR	CC 0099.8767.00	MURATA	GRM42-6COG 180F 50PT	
C538	CC 12PF+-1% 50V NPO 1206 CERAMIC CHIP CAPACITOR	CC 0099.8744.00	MURATA	GRM42-6COG 120 F50PT	
C539	CC 12PF+-1% 50V NPO 1206 CERAMIC CHIP CAPACITOR	CC 0099.8744.00	MURATA	GRM42-6COG 120 F50PT	
C540	CC 1NF+-1% 50V NPO 1206 SMD CERAMIC CAPACITOR	CC 0007.7398.00	PHILIPS_CO	2222 863 *8102	
C545	CC 27PF+-1%50V NPD 1206 CERAMIC CHIP CAPACITOR	CC 0099.8409.00	MURATA	GRM42-6COG 270F 50PT	
C546	CC 18PF+-1% 50V NPO 1206 CERAMIC CHIP CAPACITOR	CC 0099.8767.00	MURATA	GRM42-6COG 180F 50PT	
C547	CC 18PF+-1% 50V NPO 1206 CERAMIC CHIP CAPACITOR	CC 0099.8767.00	MURATA	GRM42-6COG 180F 50PT	
C553	CC 1NF+-1% 50V NPO 1206 SMD CERAMIC CAPACITOR	CC 0007.7398.00	PHILIPS_CO	2222 863 *8102	

095.0026-0693



ROHDE & SCHWARZ

28

16.09.97

EE AUSGANGSTEIL 2.08GHZ
OUTPUT UNIT 2.08GHZ

1062.7005.01 SA

3+

MENP5 413 3PUA Ai Datum Date Schaltteilliste für Parts list for Sachnummer Stock No. Blatt-Nr. Page

Für diese Unterlage behalten wir uns alle Rechte vor.

Kennz. Comp. No.	Benennung Designation	Sachnummer Stock No.	Hersteller Manufacturer	Bezeichnung Designation	enthalten in contained in
C560	CC 33PF+-1%50V NPO 1206 CERAMIC CHIP CAPACITOR	CC 0099.8780.00	MURATA	GRM42-6COG 330F 50PT	
C562	CC 27PF+-1%50V NPO 1206 CERAMIC CHIP CAPACITOR	CC 0099.8409.00	MURATA	GRM42-6COG 270F 50PT	
C564	CC 22PF+-1%50V NPO 1206 CERAMIC CHIP CAPACITOR	CC 0099.8396.00	MURATA	GRM42-6COG 220F 50PT	
C568	CC 5,6PF+-0,25 50V NPO1206 CERAMIC CHIP CAPACITOR	CC 0007.8220.00	MURATA	GRM42-6COG 5R6 C50PT	
C569	CC 1NF+-1% 50V NPO 1206 SMD CERAMIC CAPACITOR	CC 0007.7398.00	PHILIPS_CO	2222 863 *8102	
C570	CC 12PF+-1% 50V NPO 1206 CERAMIC CHIP CAPACITOR	CC 0099.8744.00	MURATA	GRM42-6COG 120 F50PT	
C571	XX ENTHALTEN IN INCLUDED IN				
C573	IN LEITERPLATTE CC 15PF+-1% 50V NPO 1206 CERAMIC CHIP CAPACITOR	CC 0099.8750.00	MURATA	GRM42-6COG 150F 50PT	
C575	CC 15PF+-1% 50V NPO 1206 CERAMIC CHIP CAPACITOR	CC 0099.8750.00	MURATA	GRM42-6COG 150F 50PT	
C580	CC 15PF+-1% 50V NPO 1206 CERAMIC CHIP CAPACITOR	CC 0099.8750.00	MURATA	GRM42-6COG 150F 50PT	
C582	CC 12PF+-1% 50V NPO 1206 CERAMIC CHIP CAPACITOR	CC 0099.8744.00	MURATA	GRM42-6COG 120 F50PT	
C583	XX ENTHALTEN IN INCLUDED IN				
C584	IN LEITERPLATTE CC 5,6PF+-0,25 50V NPO1206 CERAMIC CHIP CAPACITOR	CC 0007.8220.00	MURATA	GRM42-6COG 5R6 C50PT	
C585	CC 100NF+-10%50V X7R 1206 CERAMIC CHIP CAPACITOR	CC 0007.5237.00	PHILIPS_CO	2238 581 15649	
C599	XX ENTHALTEN IN INCLUDED IN				
C600	IN LEITERPLATTE CC 18PF+-1% 50V NPO 1206 CERAMIC CHIP CAPACITOR	CC 0099.8767.00	MURATA	GRM42-6COG 180F 50PT	
C601	CC 27NF+-10%50VX7R 1206 CERAMIC CHIP CAPACITOR	CC 0099.8473.00	PHILIPS_CO	2238 581 16633	
C602	CC 100PF+-1%50V NPO 1206 CERAMIC CHIP CAPACITOR	CC 0099.8415.00	MURATA	GRM42-6COG 101F 50PT	
C603	CC 18PF+-1% 50V NPO 1206 CERAMIC CHIP CAPACITOR	CC 0099.8767.00	MURATA	GRM42-6COG 180F 50PT	
C604	CC 10PF+-0,25 50V NPO 1206 CERAMIC CHIP CAPACITOR	CC 0099.8480.00	MURATA	GRM42-6COG 100 C50PT	
C605	CC 4,7PF+-0,25 50V NPO1206 CERAMIC CHIP CAPACITOR	CC 0007.8213.00	MURATA	GRM42-6COG 4R7C 50PT	
C606	CC 3,9PF+-0,25 50V NPO1206 CERAMIC CHIP CAPACITOR	CC 0007.8207.00	MURATA	GRM42-6COG 3R9 C50PT	
C607	CC 3,9PF+-0,25 50V NPO1206 CERAMIC CHIP CAPACITOR	CC 0007.8207.00	MURATA	GRM42-6COG 3R9 C50PT	
C608	CC 220PF+-1%50V NPO 1206 CERAMIC CHIP CAPACITOR	CC 0099.8850.00	PHILIPS_CO	2238 863 18221	
C609	CC 100NF+-10%50V X7R 1206 CERAMIC CHIP CAPACITOR	CC 0007.5237.00	PHILIPS_CO	2238 581 15649	
C610	CC 100NF+-10%50V X7R 1206 CERAMIC CHIP CAPACITOR	CC 0007.5237.00	PHILIPS_CO	2238 581 15649	
C611	CC 10PF+-0,25 50V NPO 1206 CERAMIC CHIP CAPACITOR	CC 0099.8480.00	MURATA	GRM42-6COG 100 C50PT	
C612	CC 100NF+-10%50V X7R 1206 CERAMIC CHIP CAPACITOR	CC 0007.5237.00	PHILIPS_CO	2238 581 15649	
C613	CC 100NF+-10%50V X7R 1206 CERAMIC CHIP CAPACITOR	CC 0007.5237.00	PHILIPS_CO	2238 581 15649	
C614	CC 100NF+-10%50V X7R 1206 CERAMIC CHIP CAPACITOR	CC 0007.5237.00	PHILIPS_CO	2238 581 15649	
C615	CC 100NF+-10%50V X7R 1206 CERAMIC CHIP CAPACITOR	CC 0007.5237.00	PHILIPS_CO	2238 581 15649	
C616	CC 2,2PF+-0,25 50V NPO1206 CERAMIC CHIP CAPACITOR	CC 0007.8171.00	MURATA	GRM42-6COG 2R2 C50PT	
C617	CC 4,7PF+-0,25 50V NPO1206 CERAMIC CHIP CAPACITOR	CC 0007.8213.00	MURATA	GRM42-6COG 4R7C 50PT	
C618	CC 8,2PF+-0,25 50V NPO1206 CERAMIC CHIP CAPACITOR	CC 0007.8242.00	MURATA	GRM42-6COG 8R2 C50PT	
C619	CC 8,2PF+-0,25 50V NPO1206 CERAMIC CHIP CAPACITOR	CC 0007.8242.00	MURATA	GRM42-6COG 8R2 C50PT	
C620	CC 4,7PF+-0,25 50V NPO1206 CERAMIC CHIP CAPACITOR	CC 0007.8213.00	MURATA	GRM42-6COG 4R7C 50PT	
C621	CC 1,5PF+-0,25 50V NPO1206 CERAMIC CHIP CAPACITOR	CC 0007.8159.00	MURATA	GRM42-6COG 1R5 C50PT	

MENP5	413 3PUA	Äi	Datum Date	Sachteiliste für Parts list for	Sachnummer Stock No.	Blatt-Nr. Page
	28	16.09.97	EE AUSGANGSTEIL 2.08GHZ OUTPUT UNIT 2.08GHZ	1062.7005.01 SA	4+	

095.0026-0893

Für diese Unterlage behalten wir uns alle Rechte vor.

Kennz. Comp. No.	Benennung Designation	Sachnummer Stock No.	Hersteller Manufacturer	Bezeichnung Designation	enthalten in contained in
C623	CC 220PF+-1%50V NPO 1206 CERAMIC CHIP CAPACITOR	CC 0099.8850.00	PHILIPS_CO	2238 863 18221	
C625	CC 10PF+-0,25 50VNPO 1206 CERAMIC CHIP CAPACITOR	CC 0099.8480.00	MURATA	GRM42-6COG 100 C5OPT	
C627	CC 18PF+-1% 50V NPO 1206 CERAMIC CHIP CAPACITOR	CC 0099.8767.00	MURATA	GRM42-6COG 180F 50PT	
C628	CC 100NF+-10%50V X7R 1206 CERAMIC CHIP CAPACITOR	CC 0007.5237.00	PHILIPS_CO	2238 581 15649	
C629	CE 47UF +-10% 10V 7343 TANTALUM SMD-CAPACITOR	CE 0007.7300.00	SPRAGUE	293D X9 010 D2T	
C631	CC 100NF+-10%50V X7R 1206 CERAMIC CHIP CAPACITOR	CC 0007.5237.00	PHILIPS_CO	2238 581 15649	
C632	CC 47PF+-1%50V COG 1206 CERAMIC CHIP CAPACITOR	CC 0099.8496.00	MURATA	GRM42-6COG 470F 50PT	
C633	CC 100NF+-10%50V X7R 1206 CERAMIC CHIP CAPACITOR	CC 0007.5237.00	PHILIPS_CO	2238 581 15649	
C634	CE 10UF +-10% 25V 7343 TANTALUM SMD-CAPACITOR	CE 0007.7246.00	SPRAGUE	293D 106 X9 025 D2T	
C635	CC 100NF+-10%50V X7R 1206 CERAMIC CHIP CAPACITOR	CC 0007.5237.00	PHILIPS_CO	2238 581 15649	
C636	CE 10UF +-10% 25V 7343 TANTALUM SMD-CAPACITOR	CE 0007.7246.00	SPRAGUE	293D 106 X9 025 D2T	
C637	CE 10UF +-10% 25V 7343 TANTALUM SMD-CAPACITOR	CE 0007.7246.00	SPRAGUE	293D 106 X9 025 D2T	
C638	CC 100NF+-10%50V X7R 1206 CERAMIC CHIP CAPACITOR	CC 0007.5237.00	PHILIPS_CO	2238 581 15649	
C639	CC 100NF+-10%50V X7R 1206 CERAMIC CHIP CAPACITOR	CC 0007.5237.00	PHILIPS_CO	2238 581 15649	
C640	CC 4,7PF+-0,25 50VNPO1206 CERAMIC CHIP CAPACITOR NICHT BESTUECKT NOT FITTED	CC 0007.8213.00	MURATA	GRM42-6COG 4R7C 50PT	
C641	CC 47PF+-1%50V COG 1206 CERAMIC CHIP CAPACITOR	CC 0099.8496.00	MURATA	GRM42-6COG 470F 50PT	
C642	CC 68PF+-1%50V NPO 1206 CERAMIC CHIP CAPACITOR	CC 0099.8815.00	MURATA	GRM42-6COG 680F 50PT	
C643	CC 68PF+-1%50V NPO 1206 CERAMIC CHIP CAPACITOR	CC 0099.8815.00	MURATA	GRM42-6COG 680F 50PT	
C644	CC 4,7PF+-0,25 50VNPO1206 CERAMIC CHIP CAPACITOR NICHT BESTUECKT NOT FITTED	CC 0007.8213.00	MURATA	GRM42-6COG 4R7C 50PT	
C645	CC 47PF+-1%50V COG 1206 CERAMIC CHIP CAPACITOR	CC 0099.8496.00	MURATA	GRM42-6COG 470F 50PT	
C646	CC 8,2PF+-0,25 50VNPO1206 CERAMIC CHIP CAPACITOR	CC 0007.8242.00	MURATA	GRM42-6COG 8R2 C5OPT	
C647	CC 12PF+-1% 50V NPO 1206 CERAMIC CHIP CAPACITOR	CC 0099.8744.00	MURATA	GRM42-6COG 120 F50PT	
C650	CC 100NF+-10%50V X7R 1206 CERAMIC CHIP CAPACITOR	CC 0007.5237.00	PHILIPS_CO	2238 581 15649	
C651	CC 100NF+-10%50V X7R 1206 CERAMIC CHIP CAPACITOR	CC 0007.5237.00	PHILIPS_CO	2238 581 15649	
C652	CC 100NF+-10%50V X7R 1206 CERAMIC CHIP CAPACITOR	CC 0007.5237.00	PHILIPS_CO	2238 581 15649	
C653	CC 100NF+-10%50V X7R 1206 CERAMIC CHIP CAPACITOR	CC 0007.5237.00	PHILIPS_CO	2238 581 15649	
C654	CC 10NF+-10%50V X7R 1206 CERAMIC CHIP CAPACITOR	CC 0099.8521.00	MURATA	GRM42-6X7R103K 50PT	
C656	CC 1NF+-1% 50V NPO 1206 SMD CERAMIC CAPACITOR	CC 0007.7398.00	PHILIPS_CO	2222 863 *8102	
C660	CC 100NF+-10%50V X7R 1206 CERAMIC CHIP CAPACITOR	CC 0007.5237.00	PHILIPS_CO	2238 581 15649	
C663	CC 12PF+-1% 50V NPO 1206 CERAMIC CHIP CAPACITOR	CC 0099.8744.00	MURATA	GRM42-6COG 120 F50PT	
C664	CC 12PF+-1% 50V NPO 1206 CERAMIC CHIP CAPACITOR	CC 0099.8744.00	MURATA	GRM42-6COG 120 F50PT	
C668	CC 10PF+-0,25 50VNPO 1206 CERAMIC CHIP CAPACITOR	CC 0099.8480.00	MURATA	GRM42-6COG 100 C5OPT	
C669	CC 100NF+-10%50V X7R 1206 CERAMIC CHIP CAPACITOR NICHT BESTUECKT NOT FITTED	CC 0007.5237.00	PHILIPS_CO	2238 581 15649	
C670	CC 100NF+-10%50V X7R 1206 CERAMIC CHIP CAPACITOR	CC 0007.5237.00	PHILIPS_CO	2238 581 15649	
C671	CC 100NF+-10%50V X7R 1206 CERAMIC CHIP CAPACITOR	CC 0007.5237.00	PHILIPS_CO	2238 581 15649	
C672	CC 220PF+-1%50V NPO 1206 CERAMIC CHIP CAPACITOR	CC 0099.8850.00	PHILIPS_CO	2238 863 18221	
C673	CC 220PF+-1%50V NPO 1206 CERAMIC CHIP CAPACITOR	CC 0099.8850.00	PHILIPS_CO	2238 863 18221	

MENP5

413 3PUA

Äl

Datum Date

Schaltteilliste für Parts list for

Sachnummer Stock No.

Blatt-Nr. Page



ROHDE & SCHWARZ

28

16.09.97

EE AUSGANGSTEIL 2.08GHZ

OUTPUT UNIT 2.08GHZ

1062.7005.01 SA

5+

095.0026-0693

Für diese Unterlage behalten wir uns alle Rechte vor.

Kennz. Comp. No.	Benennung Designation	Sachnummer Stock No.	Hersteller Manufacturer	Bezeichnung Designation	enthalten in contained in
C674	CC 100NF+-10%50V X7R 1206 CERAMIC CHIP CAPACITOR	CC 0007.5237.00	PHILIPS_CO	2238 581 15649	
C675	CC 220PF+-1%50V NPO 1206 CERAMIC CHIP CAPACITOR	CC 0099.8850.00	PHILIPS_CO	2238 863 18221	
C676	CC 220PF+-1%50V NPO 1206 CERAMIC CHIP CAPACITOR	CC 0099.8850.00	PHILIPS_CO	2238 863 18221	
C677	CC 100NF+-10%50V X7R 1206 CERAMIC CHIP CAPACITOR	CC 0007.5237.00	PHILIPS_CO	2238 581 15649	
C678	CC 220PF+-1%50V NPO 1206 CERAMIC CHIP CAPACITOR	CC 0099.8850.00	PHILIPS_CO	2238 863 18221	
C679	CC 1PF+-0,25 50V NPO 1206 CERAMIC CHIP CAPACITOR	CC 0099.8667.00	PHILIPS_CO	2238 863 15108	
C680	CC 1NF+-1% 50V NPO 1206 SMD CERAMIC CAPACITOR	CC 0007.7398.00	PHILIPS_CO	2222 863 *8102	
C681	CC 1NF+-1% 50V NPO 1206 SMD CERAMIC CAPACITOR	CC 0007.7398.00	PHILIPS_CO	2222 863 *8102	
C682	CC 100NF+-10%50V X7R 1206 CERAMIC CHIP CAPACITOR	CC 0007.5237.00	PHILIPS_CO	2238 581 15649	
C700	CC 1PF+-0,25 50V NPO 1206 CERAMIC CHIP CAPACITOR	CC 0099.8667.00	PHILIPS_CO	2238 863 15108	
C701	CC 1NF+-1% 50V NPO 1206 SMD CERAMIC CAPACITOR	CC 0007.7398.00	PHILIPS_CO	2222 863 *8102	
C702	CC 1NF+-1% 50V NPO 1206 SMD CERAMIC CAPACITOR	CC 0007.7398.00	PHILIPS_CO	2222 863 *8102	
C705	CC 56PF+-1%50V NPO 1206 CERAMIC CHIP CAPACITOR	CC 0099.8809.00	MURATA	GRM42-6COG 560F 50PT	
C707	CC 220PF+-1%50V NPO 1206 CERAMIC CHIP CAPACITOR	CC 0099.8850.00	PHILIPS_CO	2238 863 18221	
C708	CC 82PF+-1%50V NPO 1206 CERAMIC CHIP CAPACITOR	CC 0099.8821.00	MURATA	GRM42-6COG 820F 50PT	
C709	CC 82PF+-1%50V NPO 1206 CERAMIC CHIP CAPACITOR	CC 0099.8821.00	MURATA	GRM42-6COG 820F 50PT	
C710	CC 1NF+-1% 50V NPO 1206 SMD CERAMIC CAPACITOR	CC 0007.7398.00	PHILIPS_CO	2222 863 *8102	
C714	CC 3,9PF+-0,25 50VNPO1206 CERAMIC CHIP CAPACITOR	CC 0007.8207.00	MURATA	GRM42-6COG 3R9 C50PT	
C715	CC 220PF+-1%50V NPO 1206 CERAMIC CHIP CAPACITOR	CC 0099.8850.00	PHILIPS_CO	2238 863 18221	
C720	CC 1NF+-1% 50V NPO 1206 SMD CERAMIC CAPACITOR	CC 0007.7398.00	PHILIPS_CO	2222 863 *8102	
C721	CC 82PF+-1%50V NPO 1206 CERAMIC CHIP CAPACITOR	CC 0099.8821.00	MURATA	GRM42-6COG 820F 50PT	
C723	CC 82PF+-1%50V NPO 1206 CERAMIC CHIP CAPACITOR	CC 0099.8821.00	MURATA	GRM42-6COG 820F 50PT	
C724	CC 220PF+-1%50V NPO 1206 CERAMIC CHIP CAPACITOR	CC 0099.8850.00	PHILIPS_CO	2238 863 18221	
C725	CC 1NF+-1% 50V NPO 1206 SMD CERAMIC CAPACITOR	CC 0007.7398.00	PHILIPS_CO	2222 863 *8102	
.727					
C728	CC 100PF+-1%50V NPO 1206 CERAMIC CHIP CAPACITOR	CC 0099.8415.00	MURATA	GRM42-6COG 101F 50PT	
C729	CC 100PF+-1%50V NPO 1206 CERAMIC CHIP CAPACITOR	CC 0099.8415.00	MURATA	GRM42-6COG 101F 50PT	
C732	CC 220PF+-1%50V NPO 1206 CERAMIC CHIP CAPACITOR	CC 0099.8850.00	PHILIPS_CO	2238 863 18221	
C734	CC 82PF+-1%50V NPO 1206 CERAMIC CHIP CAPACITOR	CC 0099.8821.00	MURATA	GRM42-6COG 820F 50PT	
C735	CC 1NF+-1% 50V NPO 1206 SMD CERAMIC CAPACITOR	CC 0007.7398.00	PHILIPS_CO	2222 863 *8102	
C736	CC 82PF+-1%50V NPO 1206 CERAMIC CHIP CAPACITOR	CC 0099.8821.00	MURATA	GRM42-6COG 820F 50PT	
C738	CC 47PF+-1%50V COG 1206 CERAMIC CHIP CAPACITOR	CC 0099.8496.00	MURATA	GRM42-6COG 470F 50PT	
C740	CC 220PF+-1%50V NPO 1206 CERAMIC CHIP CAPACITOR	CC 0099.8850.00	PHILIPS_CO	2238 863 18221	
C741	CC 100NF+-10%50V X7R 1206 CERAMIC CHIP CAPACITOR	CC 0007.5237.00	PHILIPS_CO	2238 581 15649	
C742	CC 100NF+-10%50V X7R 1206 CERAMIC CHIP CAPACITOR NICHT BESTUECKT NOT FITTED	CC 0007.5237.00	PHILIPS_CO	2238 581 15649	
C743	CC 220PF+-1%50V NPO 1206 CERAMIC CHIP CAPACITOR	CC 0099.8850.00	PHILIPS_CO	2238 863 18221	
C744	CC 100NF+-10%50V X7R 1206 CERAMIC CHIP CAPACITOR NICHT BESTUECKT NOT FITTED	CC 0007.5237.00	PHILIPS_CO	2238 581 15649	
C745	CC 100NF+-10%50V X7R 1206 CERAMIC CHIP CAPACITOR	CC 0007.5237.00	PHILIPS_CO	2238 581 15649	

MENP5	413 3PUA	Äi	Datum Date	Schaltteilliste für Parts list for	Sachnummer Stock No.	Blatt-Nr. Page
	28	16.09.97	EE AUSGANGSTEIL 2.08GHZ OUTPUT UNIT 2.08GHZ	1062.7005.01 SA	6+	

095.0026-0693

Für diese Unterlage behalten wir uns alle Rechte vor.

Kennz. Comp. No.	Benennung Designation	Sachnummer Stock No.	Hersteller Manufacturer	Bezeichnung Designation	enthalten in contained in
C747	CC 100PF+-1%50V NPO 1206 CERAMIC CHIP CAPACITOR	CC 0099.8415.00	MURATA	GRM42-6COG 101F 50PT	
C748	CC 100PF+-1%50V NPO 1206 CERAMIC CHIP CAPACITOR	CC 0099.8415.00	MURATA	GRM42-6COG 101F 50PT	
C750	CC 1NF+-1% 50V NPO 1206 SMD CERAMIC CAPACITOR	CC 0007.7398.00	PHILIPS_CO	2222 863 *8102	
C751	CC 1NF+-1% 50V NPO 1206 SMD CERAMIC CAPACITOR	CC 0007.7398.00	PHILIPS_CO	2222 863 *8102	
C753	CC 100NF+-10%50V X7R 1206 CERAMIC CHIP CAPACITOR	CC 0007.5237.00	PHILIPS_CO	2238 581 15649	
..757	CC 1NF+-1% 50V NPO 1206 SMD CERAMIC CAPACITOR	CC 0007.7398.00	PHILIPS_CO	2222 863 *8102	
C762	CC 220PF+-1%50V NPO 1206 CERAMIC CHIP CAPACITOR	CC 0099.8850.00	PHILIPS_CO	2238 863 18221	
C765	CC 220PF+-1%50V NPO 1206 CERAMIC CHIP CAPACITOR	CC 0099.8850.00	PHILIPS_CO	2238 863 18221	
C766	CC 56PF+-1%50V NPO 1206 CERAMIC CHIP CAPACITOR	CC 0099.8809.00	MURATA	GRM42-6COG 560F 50PT	
C767	CC 1NF+-1% 50V NPO 1206 SMD CERAMIC CAPACITOR	CC 0007.7398.00	PHILIPS_CO	2222 863 *8102	
C768	CC 1NF+-1% 50V NPO 1206 SMD CERAMIC CAPACITOR	CC 0007.7398.00	PHILIPS_CO	2222 863 *8102	
C769	CC 220PF+-1%50V NPO 1206 CERAMIC CHIP CAPACITOR	CC 0099.8850.00	PHILIPS_CO	2238 863 18221	
C770	CC 100NF+-10%50V X7R 1206 CERAMIC CHIP CAPACITOR	CC 0007.5237.00	PHILIPS_CO	2238 581 15649	
..772	CC 220PF+-1%50V NPO 1206 CERAMIC CHIP CAPACITOR	CC 0099.8850.00	PHILIPS_CO	2238 863 18221	
C773	CC 220PF+-1%50V NPO 1206 CERAMIC CHIP CAPACITOR	CC 0099.8850.00	PHILIPS_CO	2238 863 18221	
C774	CC 220PF+-1%50V NPO 1206 CERAMIC CHIP CAPACITOR	CC 0099.8850.00	PHILIPS_CO	2238 863 18221	
C775	CC 100NF+-10%50V X7R 1206 CERAMIC CHIP CAPACITOR	CC 0007.5237.00	PHILIPS_CO	2238 581 15649	
C776	CC 33PF+-1%50V NPO 1206 CERAMIC CHIP CAPACITOR	CC 0099.8780.00	MURATA	GRM42-6COG 330F 50PT	
..781	CC 100PF+-1%50V NPO 1206 CERAMIC CHIP CAPACITOR	CC 0099.8415.00	MURATA	GRM42-6COG 101F 50PT	
C783	CC 1,2PF+-0,25 50VNPO1206 CERAMIC CHIP CAPACITOR	CC 0007.8142.00	MURATA	GRM42-6COG 1R2 C5OPT	
..794	CC 1,5PF+-0,25 50VNPO1206 CERAMIC CHIP CAPACITOR	CC 0007.8159.00	MURATA	GRM42-6COG 1R5 C5OPT	
C795	CC 1,2PF+-0,25 50VNPO1206 CERAMIC CHIP CAPACITOR	CC 0007.8142.00	MURATA	GRM42-6COG 1R2 C5OPT	
C796	CC 1,5PF+-0,25 50VNPO1206 CERAMIC CHIP CAPACITOR	CC 0007.8159.00	MURATA	GRM42-6COG 1R5 C5OPT	
C797	CC 1,2PF+-0,25 50VNPO1206 CERAMIC CHIP CAPACITOR	CC 0007.8142.00	MURATA	GRM42-6COG 1R2 C5OPT	
C798	CC 220PF+-1%50V NPO 1206 CERAMIC CHIP CAPACITOR	CC 0099.8850.00	PHILIPS_CO	2238 863 18221	
C799	CC 220PF+-1%50V NPO 1206 CERAMIC CHIP CAPACITOR	CC 0099.8850.00	PHILIPS_CO	2238 863 18221	
C800	CE 1UF +-10% 25V EIA3528 TANTALUM SMD-CAPACITOR	CE 0007.7217.00	SPRAGUE	293D 105 X9 025 B2T	
C801	CC 100PF+-1%50V NPO 1206 CERAMIC CHIP CAPACITOR	CC 0099.8415.00	MURATA	GRM42-6COG 101F 50PT	
C802	CC 100PF+-1%50V NPO 1206 CERAMIC CHIP CAPACITOR	CC 0099.8415.00	MURATA	GRM42-6COG 101F 50PT	
C803	CC 1NF+-1% 50V NPO 1206 SMD CERAMIC CAPACITOR	CC 0007.7398.00	PHILIPS_CO	2222 863 *8102	
C804	CC 1NF+-1% 50V NPO 1206 SMD CERAMIC CAPACITOR	CC 0007.7398.00	PHILIPS_CO	2222 863 *8102	
C805	CE 1UF +-10% 25V EIA3528 TANTALUM SMD-CAPACITOR	CE 0007.7217.00	SPRAGUE	293D 105 X9 025 B2T	
C806	CC 100NF+-10%50V X7R 1206 CERAMIC CHIP CAPACITOR	CC 0007.5237.00	PHILIPS_CO	2238 581 15649	
C808	CE 1UF +-10% 25V EIA3528 TANTALUM SMD-CAPACITOR	CE 0007.7217.00	SPRAGUE	293D 105 X9 025 B2T	
C810	CC 1PF+-0,25 50V NPO 1206 CERAMIC CHIP CAPACITOR NICHT BESTUECKT NOT FITTED	CC 0099.8667.00	PHILIPS_CO	2238 863 15108	
C812	CC 1PF+-0,25 50V NPO 1206 CERAMIC CHIP CAPACITOR NICHT BESTUECKT NOT FITTED	CC 0099.8667.00	PHILIPS_CO	2238 863 15108	
C816	CC 10PF+-0,25 50VNPO 1206 CERAMIC CHIP CAPACITOR	CC 0099.8480.00	MURATA	GRM42-6COG 100 C5OPT	
C817	CC 3,9PF+-0,25 50VNPO1206 CERAMIC CHIP CAPACITOR	CC 0007.8207.00	MURATA	GRM42-6COG 3R9 C5OPT	
C818	CC 3,3PF+-0,25 50VNPO1206 CERAMIC CHIP CAPACITOR	CC 0007.8194.00	MURATA	GRM42-6COG 3R3 C5OPT	
C819	CC 100PF+-1%50V NPO 1206 CERAMIC CHIP CAPACITOR	CC 0099.8415.00	MURATA	GRM42-6COG 101F 50PT	
C820	CE 1UF +-10% 25V EIA3528 TANTALUM SMD-CAPACITOR	CE 0007.7217.00	SPRAGUE	293D 105 X9 025 B2T	

095.0026-0693

MENP5	413 3PUA	Al	Datum Date	Schaltteilliste für Parts list for	Sachnummer Stock No.	Blatt-Nr. Page
	ROHDE & SCHWARZ	28	16.09.97	EE AUSGANGSTEIL 2.08GHZ OUTPUT UNIT 2.08GHZ	1062.7005.01 SA	7+

Für diese Unterlage behalten wir uns alle Rechte vor.

Kannz. Comp. No.	Benennung Designation	Sachnummer Stock No.	Hersteller Manufacturer	Bezeichnung Designation	enthalten in contained in
	NICHT BESTUECKT NOT FITTED				
C821	CE 100UF+-20%25V RDBX9,5 ELECTROLYTIC CAPACITOR	0803.0580.00	MATSUSHITA	ECE-A1ESS-101	
C828	CE 1UF +-10% 25V EIA3528 TANTALUM SMD-CAPACITOR	CE 0007.7217.00	SPRAGUE	293D 105 X9 025 B2T	
C830	CC 1PF+-0,25 50V NPO 1206 CERAMIC CHIP CAPACITOR	CC 0099.8667.00	PHILIPS_CO	2238 863 15108	
	NICHT BESTUECKT NOT FITTED				
C831	CC 3,3PF+-0,25 50VNPO1206 CERAMIC CHIP CAPACITOR	CC 0007.8194.00	MURATA	GRM42-6COG 3R3 C50PT	
C832	CC 100PF+-1%50V NPO 1206 CERAMIC CHIP CAPACITOR	CC 0099.8415.00	MURATA	GRM42-6COG 101F 50PT	
C833	CE 1UF +-10% 25V EIA3528 TANTALUM SMD-CAPACITOR	CE 0007.7217.00	SPRAGUE	293D 105 X9 025 B2T	
	NICHT BESTUECKT NOT FITTED				
C834	CE 100UF+-20%25V RDBX9,5 ELECTROLYTIC CAPACITOR	0803.0580.00	MATSUSHITA	ECE-A1ESS-101	
C835	CC 1,0PF0,1PF50V NPO 0603 SMD-CERAMIC-CAPACITOR	0009.8304.00	AVX	0603 5A *** BAT00J	
	BESTEHT AUS 001.4339 2X3MM				
C836	CE 1UF +-10% 25V EIA3528 TANTALUM SMD-CAPACITOR	CE 0007.7217.00	SPRAGUE	293D 105 X9 025 B2T	
C839	CE 1UF +-10% 25V EIA3528 TANTALUM SMD-CAPACITOR	CE 0007.7217.00	SPRAGUE	293D 105 X9 025 B2T	
C840	CC 100NF+-10%50V X7R 1206 CERAMIC CHIP CAPACITOR	CC 0007.5237.00	PHILIPS_CO	2238 581 15649	
..843	CC 100PF+-1% 50VNPO 0603 SMD-CERAMIC-CAPACITOR	CC 0009.4680.00	MURATA	GRM39COG***F50PT	
C844	CC 100NF+-10%50V X7R 1206 CERAMIC CHIP CAPACITOR	CC 0007.5237.00	PHILIPS_CO	2238 581 15649	
C846	CC 47PF+-1%50V COG 1206 CERAMIC CHIP CAPACITOR	CC 0099.8496.00	MURATA	GRM42-6COG 470F 50PT	
C847	CC 10PF+-0,1 50V NPO 0603 SMD-CERAMIC-CAPACITOR	CC 0009.4567.00	AVX	0603 5A *** BAT00J	
C848	CC 1PF+-0,25 50V NPO 1206 CERAMIC CHIP CAPACITOR	CC 0099.8667.00	PHILIPS_CO	2238 863 15108	
C849	NICHT BESTUECKT NOT FITTED				
C850	CC 100NF+-10%50V X7R 1206 CERAMIC CHIP CAPACITOR	CC 0007.5237.00	PHILIPS_CO	2238 581 15649	
..852	CC 1NF+-1% 50V NPO 1206 SMD CERAMIC CAPACITOR	CC 0007.7398.00	PHILIPS_CO	2222 863 *8102	
C853	CC 100NF+-10%50V X7R 1206 CERAMIC CHIP CAPACITOR	CC 0007.5237.00	PHILIPS_CO	2238 581 15649	
C854	CC 100NF+-10%50V X7R 1206 CERAMIC CHIP CAPACITOR	CC 0007.5237.00	PHILIPS_CO	2238 581 15649	
C855	CC 100NF+-10%50V X7R 1206 CERAMIC CHIP CAPACITOR	CC 0007.5237.00	PHILIPS_CO	2238 581 15649	
C870	CC 100NF+-10%50V X7R 1206 CERAMIC CHIP CAPACITOR	CC 0007.5237.00	PHILIPS_CO	2238 581 15649	
C871	CC 100NF+-10%50V X7R 1206 CERAMIC CHIP CAPACITOR	CC 0007.5237.00	PHILIPS_CO	2238 581 15649	
C880	CC 100NF+-10%50V X7R 1206 CERAMIC CHIP CAPACITOR	CC 0007.5237.00	PHILIPS_CO	2238 581 15649	
C881	CE 1UF +-10% 25V EIA3528 TANTALUM SMD-CAPACITOR	CE 0007.7217.00	SPRAGUE	293D 105 X9 025 B2T	
C882	CC 1NF+-1% 50V NPO 1206 SMD CERAMIC CAPACITOR	CC 0007.7398.00	PHILIPS_CO	2222 863 *8102	
C883	CC 1NF+-1% 50V NPO 1206 SMD CERAMIC CAPACITOR	CC 0007.7398.00	PHILIPS_CO	2222 863 *8102	
C884	CC 1NF+-1% 50V NPO 1206 SMD CERAMIC CAPACITOR	CC 0007.7398.00	PHILIPS_CO	2222 863 *8102	
C885	CC 100NF+-10%50V X7R 1206 CERAMIC CHIP CAPACITOR	CC 0007.5237.00	PHILIPS_CO	2238 581 15649	
..890	CC 100NF+-10%50V X7R 1206 CERAMIC CHIP CAPACITOR	CC 0007.5237.00	PHILIPS_CO	2238 581 15649	
C892	CC 1NF+-1% 50V NPO 1206 SMD CERAMIC CAPACITOR	CC 0007.7398.00	PHILIPS_CO	2222 863 *8102	
C893	CC 100PF+-1%50V NPO 1206 CERAMIC CHIP CAPACITOR	CC 0099.8415.00	MURATA	GRM42-6COG 101F 50PT	
C894	CC 100PF+-1%50V NPO 1206 CERAMIC CHIP CAPACITOR	CC 0099.8415.00	MURATA	GRM42-6COG 101F 50PT	
D10	BL PC74HCT4051T 8CH.A.MUX ANALOG MULTIPLEXER	BL 0007.6827.00	PHILIPS	(PC)74HCT4051(T)	
D100	BL PC74HCT132T 4X2IN SCHM NAND SCHMITT TRIGGER	BL 0007.6340.00	PHILIPS	(PC)74HCT132(D/T)	
D102	BL PC74HC4094T 8ST.BUSREG BUS REGISTER	BL 0804.0977.00	PHILIPS_SE	(PC)74HC4094(D/T)	

095.0028-0693



28

16.09.97

EE AUSGANGSTEIL 2.08GHZ
OUTPUT UNIT 2.08GHZ

1062.7005.01 SA

8+

Für diese Unterlage behalten wir uns alle Rechte vor.

Kennz. Comp. No.	Benennung Designation	Sachnummer Stock No.	Hersteller Manufacturer	Bezeichnung Designation	enthalten in contained in
D105	BL PC74HC08T 4X2IN.ANDG QUAD 2INPUT AND GATE	BL 0007.3486.00	PHILIPS_SE	(PC)74HC08(D/T)	
D110	BL PC74HC4094T 8ST.BUSREG BUS REGISTER	BL 0804.0977.00	PHILIPS_SE	(PC)74HC4094(D/T)	
D111	BL PC74HC08T 4X2IN.ANDG QUAD 2INPUT AND GATE	BL 0007.3486.00	PHILIPS_SE	(PC)74HC08(D/T)	
D112	BL PC74HC08T 4X2IN.ANDG QUAD 2INPUT AND GATE	BL 0007.3486.00	PHILIPS_SE	(PC)74HC08(D/T)	
D115	BL PC74HC86T 4X2IN EXOR QUAD 2INPUT EXOOR GATE	BL 0007.3511.00	PHILIPS_SE	(PC)74HC86(D/T)	
D120	BL PC74HC4094T 8ST.BUSREG BUS REGISTER	BL 0804.0977.00	PHILIPS_SE	(PC)74HC4094(D/T)	
D140	BJ DAC8143 1X12B-DAC 12B SERIAL D/A-CONVERTER	1012.9510.00	PMI	DAC8143FS	
D141	BS DG413DY 2A2R ANALOGSCH QUAD ANALOG CMOS.SWITCH	1004.7058.00	SILICONIX	DG413DY	
D145	BJ DAC8143 1X12B-DAC 12B SERIAL D/A-CONVERTER	1012.9510.00	PMI	DAC8143FS	
D150	BJ DAC8143 1X12B-DAC 12B SERIAL D/A-CONVERTER	1012.9510.00	PMI	DAC8143FS	
D200	BS DG413DY 2A2R ANALOGSCH QUAD ANALOG CMOS.SWITCH	1004.7058.00	SILICONIX	DG413DY	
D210	BS DG413DY 2A2R ANALOGSCH QUAD ANALOG CMOS.SWITCH	1004.7058.00	SILICONIX	DG413DY	
D220	BS DG413DY 2A2R ANALOGSCH QUAD ANALOG CMOS.SWITCH	1004.7058.00	SILICONIX	DG413DY	
D430	BL PC74HCT42T BCD/D. DEC DECODER	BL 0007.6240.00	PHILIPS	(PC)74HCT42(T)	
D431	BL PC74HCT04T 6XINVERT HEXINVERTER	BL 0007.5372.00	PHILIPS_SE	(PC)74HCT04(D/T)	
D432	BL PC74HCT04T 6XINVERT HEXINVERTER	BL 0007.5372.00	PHILIPS_SE	(PC)74HCT04(D/T)	
D759	BM SW-239 GAAS SPDTSWITCH GAAS RF-SWITCH	0853.5579.00	ANZAC	SW239	
D760	BM SW-239 GAAS SPDTSWITCH GAAS RF-SWITCH	0853.5579.00	ANZAC	SW239	
D800	BM SW-239 GAAS SPDTSWITCH GAAS RF-SWITCH	0853.5579.00	ANZAC	SW239	
L20	LD 10 UH 10% 3R3 144 MA CHOKE	LD 0026.4184.00	DALE	IM2	
L21	LD 470NH 10% 0,15A 1210 SMD-INDUCTOR	LD 0007.9926.00	SIEMENS	B82422-A3471-K100	
L22	LD 470NH 10% 0,15A 1210 SMD-INDUCTOR	LD 0007.9926.00	SIEMENS	B82422-A3471-K100	
L300	LD 220NH 10% 0,28A 1210 SMD-INDUCTOR	LD 0520.7911.00	SIEMENS	B82422-A3221-K100	
L301	LD 22NH 10% 0,60A 1210 SMD-INDUCTOR	1002.4897.00	SIEMENS	B82422-A3220-K100	
L305	LD 1,00UH10%1,00DHMO,390A CHOKE	LD 0067.2863.00	DALE	IM2	
L325	LD 1,00UH10%1,00DHMO,390A CHOKE	LD 0067.2863.00	DALE	IM2	
L340	LD 1,00UH10%1,00DHMO,390A CHOKE	LD 0067.2863.00	DALE	IM2	
L350	XX ENTHALTEN IN INCLUDED IN IN LEITERPLATTE				
L351	LD 1,00UH10%1,00DHMO,390A CHOKE NICHT BESTUECKT NOT FITTED	LD 0067.2863.00	DALE	IM2	
L353	LD 1,00UH10%1,00DHMO,390A CHOKE NICHT BESTUECKT NOT FITTED	LD 0067.2863.00	DALE	IM2	
L355	LD 220NH 10% 0,28A 1210 SMD-INDUCTOR	LD 0520.7911.00	SIEMENS	B82422-A3221-K100	
L360	LD 1,00UH10%1,00DHMO,390A CHOKE	LD 0067.2863.00	DALE	IM2	
L361	LD 1,00UH10%1,00DHMO,390A CHOKE	LD 0067.2863.00	DALE	IM2	
L380	XX ENTHALTEN IN INCLUDED IN IN LEITERPLATTE				
L400	LD 0,82UH10%0,85DHMO,420A CHOKE	LD 0067.2857.00	DALE	IM2	

MENP5	413 3PUA	Äl	Datum Date	Schaltteilliste für Parts list for	Sachnummer Stock No.	Blatt-Nr. Page
		28	16.09.97	EE AUSGANGSTEIL 2.08GHZ OUTPUT UNIT 2.08GHZ	1062.7005.01 SA	9+

095.0026-0893

Kennz. Comp. No.	Benennung Designation	Sachnummer Stock No.	Hersteller Manufacturer	Bezeichnung Designation	enthalten in contained in
L410	LD 0,68UH10%0,600HMO,500A CHOKE	LD 0067.2840.00	DALE	IM2	
L416	LD 1,00UH10%1,000HMO,390A CHOKE	LD 0067.2863.00	DALE	IM2	
L417	LD 1,00UH10%1,000HMO,390A CHOKE	LD 0067.2863.00	DALE	IM2	
L431	LD 1UH 10% 0,38A 1210 SMD-INDUCTOR	LD 6006.0130.00	SIEMENS	B82422-A1102-K100	
L432	LD 1UH 10% 0,38A 1210 SMD-INDUCTOR	LD 6006.0130.00	SIEMENS	B82422-A1102-K100	
L500	LD 1,20UH10%0,180HMO,620A CHOKE	LD 0067.2870.00	DALE	IM2	
L505	LD 100NH 10% 0,080HM 1,4A CHOKE	LD 0067.2740.00	DALE	IM2	
L510	LD 0,33UH10%0,220HMO,830A CHOKE	LD 0067.2805.00	DALE	IM2	
L517	LD 0,15UH10%0,100HM1,230A CHOKE	LD 0067.2763.00	DALE	IM2	
L520	LD 0,82UH10%0,850HMO,420A CHOKE	LD 0067.2857.00	DALE	IM2	
L530	LD 3,30UH10%0,850HMO,285A CHOKE	LD 0067.2928.00	DALE	IM2	
L532	LD 22NH 10% 0,60A 1210 SMD-INDUCTOR	1002.4897.00	SIEMENS	B82422-A3220-K100	
..534					
L536	LD 3,30UH10%0,850HMO,285A CHOKE	LD 0067.2928.00	DALE	IM2	
L537	LD 22NH 10% 0,60A 1210 SMD-INDUCTOR	1002.4897.00	SIEMENS	B82422-A3220-K100	
L538	LD 47NH 10% 0,51A 1210 SMD-INDUCTOR	0008.5976.00	SIEMENS	B82422-A3470-K100	
L539	LD 47NH 10% 0,51A 1210 SMD-INDUCTOR	0008.5976.00	SIEMENS	B82422-A3470-K100	
L540	LD 22NH 10% 0,60A 1210 SMD-INDUCTOR	1002.4897.00	SIEMENS	B82422-A3220-K100	
..542					
L543	LD 3,30UH10%0,850HMO,285A CHOKE	LD 0067.2928.00	DALE	IM2	
L544	LD 22NH 10% 0,60A 1210 SMD-INDUCTOR	1002.4897.00	SIEMENS	B82422-A3220-K100	
L545	LD 47NH 10% 0,51A 1210 SMD-INDUCTOR	0008.5976.00	SIEMENS	B82422-A3470-K100	
..547					
L548	LD 22NH 10% 0,60A 1210 SMD-INDUCTOR	1002.4897.00	SIEMENS	B82422-A3220-K100	
L549	LD 22NH 10% 0,60A 1210 SMD-INDUCTOR	1002.4897.00	SIEMENS	B82422-A3220-K100	
..551					
L553	LD 3,30UH10%0,850HMO,285A CHOKE	LD 0067.2928.00	DALE	IM2	
L559	LD 22NH 10% 0,60A 1210 SMD-INDUCTOR	1002.4897.00	SIEMENS	B82422-A3220-K100	
L560	LD 47NH 10% 0,51A 1210 SMD-INDUCTOR	0008.5976.00	SIEMENS	B82422-A3470-K100	
L561	LD 22NH 10% 0,60A 1210 SMD-INDUCTOR	1002.4897.00	SIEMENS	B82422-A3220-K100	
L562	LD 100NH 10% 0,44A 1210 SMD-INDUCTOR	LD 0007.9249.00	SIEMENS	B82422-A3101-K100	
L563	LD 47NH 10% 0,51A 1210 SMD-INDUCTOR	0008.5976.00	SIEMENS	B82422-A3470-K100	
L564	LD 100NH 10% 0,44A 1210 SMD-INDUCTOR	LD 0007.9249.00	SIEMENS	B82422-A3101-K100	
L565	LD 47NH 10% 0,51A 1210 SMD-INDUCTOR	0008.5976.00	SIEMENS	B82422-A3470-K100	
L566	LD 47NH 10% 0,51A 1210 SMD-INDUCTOR	0008.5976.00	SIEMENS	B82422-A3470-K100	
L568	LD 3,30UH10%0,850HMO,285A CHOKE	LD 0067.2928.00	DALE	IM2	
L570	LD 22NH 10% 0,60A 1210 SMD-INDUCTOR	1002.4897.00	SIEMENS	B82422-A3220-K100	
..572					
L580	LD 22NH 10% 0,60A 1210 SMD-INDUCTOR	1002.4897.00	SIEMENS	B82422-A3220-K100	
L583	LD 22NH 10% 0,60A 1210 SMD-INDUCTOR	1002.4897.00	SIEMENS	B82422-A3220-K100	
L584	LD 22NH 10% 0,60A 1210 SMD-INDUCTOR	1002.4897.00	SIEMENS	B82422-A3220-K100	
L585	LD 1UH 10% 0,38A 1210 SMD-INDUCTOR	LD 6006.0130.00	SIEMENS	B82422-A1102-K100	
L600	LD 1,00UH10%1,000HMO,390A CHOKE	LD 0067.2863.00	DALE	IM2	
..602					
L604	LD 1UH 10% 0,38A 1210 SMD-INDUCTOR	LD 6006.0130.00	SIEMENS	B82422-A1102-K100	

Für diese Unterlage behalten wir uns alle Rechte vor.

MENP5	413 3PUA	ÄI	Datum Date	Schaltteilliste für Parts list for	Sachnummer Stock No.	Blatt-Nr. Page
	28	16.09.97	EE AUSGANGSTEIL 2.08GHZ OUTPUT UNIT 2.08GHZ	1062.7005.01 SA	10+	

085.0026-0893

Für diese Unterlage behalten
wir uns alle Rechte vor.

Kannz. Comp. No.	Benennung Designation	Sachnummer Stock No.	Hersteller Manufacturer	Bezeichnung Designation	enthalten in contained in
L608	LD 12NH 10% 0,70A 1210 SMD-INDUCTOR	1002.4900.00	SIEMENS	B82422-A3120-K100	
L610	LD 12NH 10% 0,70A 1210 SMD-INDUCTOR	1002.4900.00	SIEMENS	B82422-A3120-K100	
L612	LD 1UH 10% 0,38A 1210 SMD-INDUCTOR	LD 6006.0130.00	SIEMENS	B82422-A1102-K100	
L613	LD 1UH 10% 0,38A 1210 SMD-INDUCTOR	LD 6006.0130.00	SIEMENS	B82422-A1102-K100	
L630	LD 47NH 10% 0,51A 1210 SMD-INDUCTOR	0008.5976.00	SIEMENS	B82422-A3470-K100	
L632	LD 22NH 10% 0,60A 1210 SMD-INDUCTOR	1002.4897.00	SIEMENS	B82422-A3220-K100	
L633	LD 22NH 10% 0,60A 1210 SMD-INDUCTOR	1002.4897.00	SIEMENS	B82422-A3220-K100	
L642	LD 1,00UH10%1,000HMO,390A CHOKE	LD 0067.2863.00	DALE	IM2	
L643	LD 0,27UH10%0,160HMO,975A CHOKE	LD 0067.2792.00	DALE	IM2	
L645	LD 0,15UH10%0,100HM1,230A CHOKE	LD 0067.2763.00	DALE	IM2	
L647	LD 0,18UH10%0,120HM1,120A CHOKE	LD 0067.2770.00	DALE	IM2	
L649	LD 0,15UH10%0,100HM1,230A CHOKE	LD 0067.2763.00	DALE	IM2	
L650	LD 22NH 10% 0,60A 1210 SMD-INDUCTOR	1002.4897.00	SIEMENS	B82422-A3220-K100	
L651	LD 22NH 10% 0,60A 1210 SMD-INDUCTOR	1002.4897.00	SIEMENS	B82422-A3220-K100	
L660	LD 1UH 10% 0,38A 1210 SMD-INDUCTOR	LD 6006.0130.00	SIEMENS	B82422-A1102-K100	
L668	LD 1UH 10% 0,38A 1210 SMD-INDUCTOR	LD 6006.0130.00	SIEMENS	B82422-A1102-K100	
L669	LD 1,00UH10%1,000HMO,390A CHOKE	LD 0067.2863.00	DALE	IM2	
L670	LD 1UH 10% 0,38A 1210 SMD-INDUCTOR	LD 6006.0130.00	SIEMENS	B82422-A1102-K100	
L671	LD 1UH 10% 0,38A 1210 SMD-INDUCTOR	LD 6006.0130.00	SIEMENS	B82422-A1102-K100	
L672	LD 1,00UH10%1,000HMO,390A CHOKE NICHT BESTUECKT NOT FITTED	LD 0067.2863.00	DALE	IM2	
L673	LD 1,00UH10%1,000HMO,390A CHOKE NICHT BESTUECKT NOT FITTED	LD 0067.2863.00	DALE	IM2	
L674	LD 0,82UH10%0,850HMO,420A CHOKE	LD 0067.2857.00	DALE	IM2	
L675	LD 1,00UH10%1,000HMO,390A CHOKE	LD 0067.2863.00	DALE	IM2	
L705	LD 220NH 10% 0,28A 1210 SMD-INDUCTOR	LD 0520.7911.00	SIEMENS	B82422-A3221-K100	
L706	LD 220NH 10% 0,28A 1210 SMD-INDUCTOR	LD 0520.7911.00	SIEMENS	B82422-A3221-K100	
L709	LD 4,7UH 10% 0,15A 1210 SMD-INDUCTOR	LD 0008.1687.00	SIEMENS	B82422-A1472-K100	
L714	LD 100NH 10% 0,44A 1210 SMD-INDUCTOR	LD 0007.9249.00	SIEMENS	B82422-A3101-K100	
L720	LD 4,7UH 10% 0,15A 1210 SMD-INDUCTOR	LD 0008.1687.00	SIEMENS	B82422-A1472-K100	
L727	LD 1UH 10% 0,38A 1210 SMD-INDUCTOR	LD 6006.0130.00	SIEMENS	B82422-A1102-K100	
L730	LD 100NH 10% 0,44A 1210 SMD-INDUCTOR	LD 0007.9249.00	SIEMENS	B82422-A3101-K100	
L732	LD 4,7UH 10% 0,15A 1210 SMD-INDUCTOR	LD 0008.1687.00	SIEMENS	B82422-A1472-K100	
L738	LD 100NH 10% 0,44A 1210 SMD-INDUCTOR	LD 0007.9249.00	SIEMENS	B82422-A3101-K100	
L739	LD 100NH 10% 0,44A 1210 SMD-INDUCTOR	LD 0007.9249.00	SIEMENS	B82422-A3101-K100	
L740	LD 0,82UH10%0,850HMO,420A CHOKE NICHT BESTUECKT NOT FITTED	LD 0067.2857.00	DALE	IM2	
L742	LD 1,00UH10%1,000HMO,390A CHOKE NICHT BESTUECKT	LD 0067.2863.00	DALE	IM2	

095.0028-0693

MENP5	413 3PUA	ÄI	Datum Date	Schaltteilliste für Parts list for	Sachnummer Stock No.	Blatt-Nr. Page
	ROHDE & SCHWARZ	28	16.09.97	EE AUSGANGSTEIL 2.08GHZ OUTPUT UNIT 2.08GHZ	1062.7005.01 SA	11+

Für diese Unterlage behalten wir uns alle Rechte vor.

Kennz. Comp. No.	Benennung Designation	Sachnummer Stock No.	Hersteller Manufacturer	Bezeichnung Designation	enthalten in contained in
L748	NOT FITTED XX ENTHALTEN IN INCLUDED IN IN LEITERPLATTE				
L754	LD 1UH 10% 0,38A 1210	LD 6006.0130.00	SIEMENS	B82422-A1102-K100	
L756	SMD-INDUCTOR				
L765	LD 1,00UH10%1,000HMO,390A	LD 0067.2863.00	DALE	IM2	
L768	CHOKE				
L770	LD 1,00UH10%1,000HMO,390A	LD 0067.2863.00	DALE	IM2	
	CHOKE				
	NICHT BESTUECKT				
L771	NOT FITTED LD 1,00UH10%1,000HMO,390A	LD 0067.2863.00	DALE	IM2	
	CHOKE				
	NICHT BESTUECKT				
L800	NOT FITTED LD 0,82UH10%0,850HMO,420A	LD 0067.2857.00	DALE	IM2	
	CHOKE				
L801	LD 1,00UH10%1,000HMO,390A	LD 0067.2863.00	DALE	IM2	
	CHOKE				
L816	LD 12NH 10% 0,70A 1210	1002.4900.00	SIEMENS	B82422-A3120-K100	
	SMD-INDUCTOR				
L817	LD 3,9MH 0,2A 200HM	1020.5256.00	SIEMENS	B82500-C-A2	
	INTERFERENCE CHOKE				
	IN LEITERPLATTE				
L818	LD SMD-DR.Z=850 OHM 100MH	1085.1661.00	PHILIPS	WBS2.5-5/4.8/10-4B1	
	CHOKE				
L819	LD 2,2UH 10% 0,27A 1210	LD 0520.7870.00	SIEMENS	B82422-A1222-K100	
	SMD-INDUCTOR				
L829	LD SMD-DR.Z=850 OHM 100MH	1085.1661.00	PHILIPS	WBS2.5-5/4.8/10-4B1	
	CHOKE				
L830	LD 2,2UH 10% 0,27A 1210	LD 0520.7870.00	SIEMENS	B82422-A1222-K100	
	SMD-INDUCTOR				
L831	LD 3,9MH 0,2A 200HM	1020.5256.00	SIEMENS	B82500-C-A2	
	INTERFERENCE CHOKE				
	IN LEITERPLATTE				
L840	LD 1UH 10% 0,38A 1210	LD 6006.0130.00	SIEMENS	B82422-A1102-K100	
	SMD-INDUCTOR				
L841	LD 1UH 10% 0,38A 1210	LD 6006.0130.00	SIEMENS	B82422-A1102-K100	
	SMD-INDUCTOR				
L845	LD 100UH 10% 0,06A 1210	LD 0007.9261.00	SIEMENS	B82422-A1104-K100	
	SMD-INDUCTOR				
L880	LD 1,20UH10%0,180HMO,620A	LD 0067.2870.00	DALE	IM2	
	CHOKE				
L885	LD 1UH 10% 0,38A 1210	LD 6006.0130.00	SIEMENS	B82422-A1102-K100	
	SMD-INDUCTOR				
N20	BO TLO74ACD 4XFET OPAMP	0007.7823.00	TEXAS	TLO74A(CD)	
	OPERATIONAL AMPLIFIER				
N130	BO NE5532D 2XLN OPAMP	0007.7798.00	SIGNETICS	NE5532D	
	OPERATIONAL AMPLIFIER				
N131	BO NE5532D 2XLN OPAMP	0007.7798.00	SIGNETICS	NE5532D	
	OPERATIONAL AMPLIFIER				
N223	BO TLO72ACD 2XFET OPAMP	0803.1057.00	TEXAS	TL 072 ACDR	
	OPERATIONAL AMPLIFIER				
N228	BO TLO72ACD 2XFET OPAMP	0803.1057.00	TEXAS	TL 072 ACDR	
	OPERATIONAL AMPLIFIER				
N235	BO NE5534D OPAMP	0815.7555.00	SIGNETICS	NE5534(D)	
	OPERATIONAL AMPLIFIER				
N275	BO TLO72ACD 2XFET OPAMP	0803.1057.00	TEXAS	TL 072 ACDR	
	OPERATIONAL AMPLIFIER				
N276	BO TLO72ACD 2XFET OPAMP	0803.1057.00	TEXAS	TL 072 ACDR	
	OPERATIONAL AMPLIFIER				
N300	BM MSA0486 DC-3.2G MMIC	0846.4293.00	AVANTEK	MSA-0486	
	BROADBAND AMPLIFIER				
	NICHT BESTUECKT				
	NOT FITTED				
N360	BM MSA1105 05-1.3G MMIC	1051.4051.00	AVANTEK	MSA-1105-TR1	
	IC MICROWAVE MONOLITH AMP				
N600	BO TLO74ACD 4XFET OPAMP	0007.7823.00	TEXAS	TLO74A(CD)	
	OPERATIONAL AMPLIFIER				
N610	BO AD744KR FET OPAMP	0854.1754.00	ANALOG_DEV (AD)744KR		
	BIFET OPAMP				
N740	BM MSA0486 DC-3.2G MMIC	0846.4293.00	AVANTEK	MSA-0486	
	BROADBAND AMPLIFIER				
	NICHT BESTUECKT				
	NOT FITTED				

MENP5

413 3PUA

ÄI

Datum

Date

Schaltteilliste für
Parts list for

Sachnummer
Stock No.

Blatt-Nr.
Page

 **ROHDE & SCHWARZ**

28

16.09.97

EE AUSGANGSTEIL 2.08GHZ

OUTPUT UNIT 2.08GHZ

1062.7005.01 SA

12+

Für diese Unterlage behalten
wir uns alle Rechte vor.

Kennz. Comp. No.	Benennung Designation	Sachnummer Stock No.	Hersteller Manufacturer	Bezeichnung Designation	enthalten in contained in	
N776 ..778	BO NE5532D 2XLN OPAMP OPERATIONAL AMPLIFIER	0007.7798.00	SIGNETICS	NE5532D		
N840	BO TLO74ACD 4XFET OPAMP OPERATIONAL AMPLIFIER	0007.7823.00	TEXAS	TLO74A(CD)		
N845	BO AD744KR FET OPAMP BIFET OPAMP	0854.1754.00	ANALOG_DEV	(AD)744KR		
P300	VL EINPRESSTIFT L=6,8 PIN	VL 0010.7250.00	AMP	1-928776-5		
P305	VL EINPRESSTIFT L=6,8 PIN	VL 0010.7250.00	AMP	1-928776-5		
P352	VL EINPRESSTIFT L=6,8 PIN	VL 0010.7250.00	AMP	1-928776-5		
P353	VL EINPRESSTIFT L=6,8 PIN	VL 0010.7250.00	AMP	1-928776-5		
P375	VL EINPRESSTIFT L=6,8 PIN	VL 0010.7250.00	AMP	1-928776-5		
P380	VL EINPRESSTIFT L=6,8 PIN	VL 0010.7250.00	AMP	1-928776-5		
P385	VL EINPRESSTIFT L=6,8 PIN	VL 0010.7250.00	AMP	1-928776-5		
P600	VL EINPRESSTIFT L=6,8 PIN	VL 0010.7250.00	AMP	1-928776-5		
P601	VL EINPRESSTIFT L=6,8 PIN	VL 0010.7250.00	AMP	1-928776-5		
P620	VL EINPRESSTIFT L=6,8 PIN	VL 0010.7250.00	AMP	1-928776-5		
P621	VL EINPRESSTIFT L=6,8 PIN	VL 0010.7250.00	AMP	1-928776-5		
P628	VL EINPRESSTIFT L=6,8 PIN	VL 0010.7250.00	AMP	1-928776-5		
P848	VL EINPRESSTIFT L=6,8 PIN	VL 0010.7250.00	AMP	1-928776-5		
P866	VL EINPRESSTIFT L=6,8 PIN	VL 0010.7250.00	AMP	1-928776-5		
R1	RG 100 OHM+-1%TK100 1206 CHIP RESISTOR	RG 0006.8884.00	ROEDERSTEI	DC2 100OHM 1%TK100		
R9	RG 10,OKOHM+-1%TK100 1206 RG CHIP RESISTOR	RG 0007.0793.00	ROEDERSTEI	DC2 10,OKOHM 1%TK100		
R10	RG 10,OKOHM+-1%TK100 1206 RG CHIP RESISTOR	RG 0007.0793.00	ROEDERSTEI	DC2 10,OKOHM 1%TK100		
R11	RG 182 KOHM+-1%TK100 1206 RESISTOR CHIP	RG 0007.5989.00	ROEDERSTEI	DC2 182KOHM 1%TK100		
R12	RG 121,OKOH+-1%TK100 1206 CHIP RESISTOR	RG 0007.1960.00	RESISTA	DC2 121KOHM 1% TK100		
R13	RG 121,OKOH+-1%TK100 1206 CHIP RESISTOR	RG 0007.1960.00	RESISTA	DC2 121KOHM 1% TK100		
R14	RG 56,2KOHM+-1%TK100 1206 CHIP RESISTOR	RG 0007.1883.00	ROEDERSTEI	DC2 56,2KOHM 1%TK100		
R15	RG 27,4KOHM+-1%TK100 1206 RESISTOR CHIP	RG 0007.5895.00	ROEDERSTEI	DC2 27,4KOHM 1%TK100		
R16	RG 1,0MOHM+-1%TK100 1206 CHIP RESISTOR	RG 0815.7532.00	DRALORIC	CRC 1206		
R17	RG 100 OHM+-1%TK100 1206 CHIP RESISTOR	RG 0006.8884.00	ROEDERSTEI	DC2 100OHM 1%TK100		
R20	RG 47,5 OHM+-1%TK100 1206 RESISTOR CHIP	RG 0007.5566.00	ROEDERSTEI	DC2 47,5OHM 1%TK100		
R21	RG 100 OHM+-1%TK100 1206 CHIP RESISTOR	RG 0006.8884.00	ROEDERSTEI	DC2 100OHM 1%TK100		
R22	RG 47,5 OHM+-1%TK100 1206 RESISTOR CHIP	RG 0007.5566.00	ROEDERSTEI	DC2 47,5OHM 1%TK100		
..25	RG 10,OKOHM+-1%TK100 1206 RG CHIP RESISTOR	RG 0007.0793.00	ROEDERSTEI	DC2 10,OKOHM 1%TK100		
R26	RG 47,5 OHM+-1%TK100 1206 RESISTOR CHIP	RG 0007.5566.00	ROEDERSTEI	DC2 47,5OHM 1%TK100		
R27	RG 10,OKOHM+-1%TK100 1206 RG CHIP RESISTOR	RG 0007.0793.00	ROEDERSTEI	DC2 10,OKOHM 1%TK100		
..32	RG 47,5 OHM+-1%TK100 1206 RESISTOR CHIP	RG 0007.5566.00	ROEDERSTEI	DC2 47,5OHM 1%TK100		
R33	RG 100 OHM+-1%TK100 1206 CHIP RESISTOR	RG 0006.8884.00	ROEDERSTEI	DC2 100OHM 1%TK100		
R34	RG 100 OHM+-1%TK100 1206 CHIP RESISTOR	RG 0006.8884.00	ROEDERSTEI	DC2 100OHM 1%TK100		
R35	RG 2,0 KOHM+-1%TK100 1206 RESISTOR CHIP	RG 0007.5737.00	ROEDERSTEI	DC2 2,OKOHM 1%TK100		
R36	RG 1,0MOHM+-1%TK100 1206 CHIP RESISTOR	RG 0815.7532.00	DRALORIC	CRC 1206		
R38	RG 10,OKOHM+-1%TK100 1206 RG CHIP RESISTOR	RG 0007.0793.00	ROEDERSTEI	DC2 10,OKOHM 1%TK100		
R41	RG 10,OKOHM+-1%TK100 1206 RG CHIP RESISTOR	RG 0007.0793.00	ROEDERSTEI	DC2 10,OKOHM 1%TK100		
..48						
MENP5	413 3PUA	ÄI	Datum Date	Schaltteilliste für Parts list for	Sachnummer Stock No.	Blatt-Nr. Page
	ROHDE & SCHWARZ	28	16.09.97	EE AUSGANGSTEIL 2.08GHZ OUTPUT UNIT 2.08GHZ	1062.7005.01 SA	13+

095.0026-0693

Für diese Unterlage behalten wir uns alle Rechte vor.

Kennz. Comp. No.	Benennung Designation	Sachnummer Stock No.	Hersteller Manufacturer	Bezeichnung Designation	enthalten in contained in
R49 ..56	RG 20,OKOHM+-1%TK100 1206 RESISTOR CHIP	RG 0007.5866.00	ROEDERSTEI	DC2 20,OKOHM 1%TK100	
R116	RG 10,OKOHM+-1%TK100 1206 RG CHIP RESISTOR	RG 0007.0793.00	ROEDERSTEI	DC2 10,OKOHM 1%TK100	
R117	RG 10,OKOHM+-1%TK100 1206 RG CHIP RESISTOR	RG 0007.0793.00	ROEDERSTEI	DC2 10,OKOHM 1%TK100	
R119	RG 825 OHM+-1%TK100 1206 CHIP RESISTOR	RG 0006.7259.00	ROEDERSTEI	DC2 825OHM 1%TK100	
R120 ..122	RG 100,OKOH+-1%TK100 1206 CHIP RESISTOR	RG 0007.1948.00	ROEDERSTEI	DC2 100KOHM 1%TK100	
R123	RG 10,OKOHM+-1%TK100 1206 RG CHIP RESISTOR	RG 0007.0793.00	ROEDERSTEI	DC2 10,OKOHM 1%TK100	
R124	RG 10,OKOHM+-1%TK100 1206 RG CHIP RESISTOR	RG 0007.0793.00	ROEDERSTEI	DC2 10,OKOHM 1%TK100	
R130 ..132	RG 10,OKOHM+-1%TK100 1206 RG CHIP RESISTOR	RG 0007.0793.00	ROEDERSTEI	DC2 10,OKOHM 1%TK100	
R133	RG 0-OHM WIDERSTAND-CHIP RESISTOR CHIP 0-OHM	RG 0007.5108.00	DRALORIC	CR 1206	
R134	RG 10,OKOHM+-1%TK100 1206 RG CHIP RESISTOR	RG 0007.0793.00	ROEDERSTEI	DC2 10,OKOHM 1%TK100	
R149	RG 10,OKOHM+-1%TK100 1206 RG CHIP RESISTOR	RG 0007.0793.00	ROEDERSTEI	DC2 10,OKOHM 1%TK100	
R160	RG 100,OKOH+-1%TK100 1206 CHIP RESISTOR	RG 0007.1948.00	ROEDERSTEI	DC2 100KOHM 1%TK100	
R161	RG 100,OKOH+-1%TK100 1206 CHIP RESISTOR	RG 0007.1948.00	ROEDERSTEI	DC2 100KOHM 1%TK100	
R162	RG 1,0 KO +-1%TK100 1206 CHIP RESISTOR	RG 0006.7271.00	ROEDERSTEI	DC2 1,OKOHM 1%TK100	
R163	RG 1,0 KO +-1%TK100 1206 CHIP RESISTOR	RG 0006.7271.00	ROEDERSTEI	DC2 1,OKOHM 1%TK100	
R165	RG 100,OKOH+-1%TK100 1206 CHIP RESISTOR	RG 0007.1948.00	ROEDERSTEI	DC2 100KOHM 1%TK100	
R166	RG 100,OKOH+-1%TK100 1206 CHIP RESISTOR	RG 0007.1948.00	ROEDERSTEI	DC2 100KOHM 1%TK100	
R167	RG 1,0 KO +-1%TK100 1206 CHIP RESISTOR	RG 0006.7271.00	ROEDERSTEI	DC2 1,OKOHM 1%TK100	
R168	RG 1,0 KO +-1%TK100 1206 CHIP RESISTOR	RG 0006.7271.00	ROEDERSTEI	DC2 1,OKOHM 1%TK100	
R170	RG 100,OKOH+-1%TK100 1206 CHIP RESISTOR	RG 0007.1948.00	ROEDERSTEI	DC2 100KOHM 1%TK100	
R171	RG 100,OKOH+-1%TK100 1206 CHIP RESISTOR	RG 0007.1948.00	ROEDERSTEI	DC2 100KOHM 1%TK100	
R172	RG 1,0 KO +-1%TK100 1206 CHIP RESISTOR	RG 0006.7271.00	ROEDERSTEI	DC2 1,OKOHM 1%TK100	
R173	RG 1,0 KO +-1%TK100 1206 CHIP RESISTOR	RG 0006.7271.00	ROEDERSTEI	DC2 1,OKOHM 1%TK100	
R206	RG 0-OHM WIDERSTAND-CHIP RESISTOR CHIP 0-OHM NICHT BESTUECKT NOT FITTED	RG 0007.5108.00	DRALORIC	CR 1206	
R207	RG 10,OKOHM+-1%TK100 1206 RG CHIP RESISTOR	RG 0007.0793.00	ROEDERSTEI	DC2 10,OKOHM 1%TK100	
R208	RG 10,OKOHM+-1%TK100 1206 RG CHIP RESISTOR	RG 0007.0793.00	ROEDERSTEI	DC2 10,OKOHM 1%TK100	
R209	RG 10,OKOHM+-1%TK100 1206 RG CHIP RESISTOR NICHT BESTUECKT NOT FITTED	RG 0007.0793.00	ROEDERSTEI	DC2 10,OKOHM 1%TK100	
R211	RG 3,01KOHM+-1%TK100 1206 RESISTOR CHIP	RG 0007.5772.00	ROEDERSTEI	DC2 3,01KOHM 1%TK100	
R211	NUR VAR/ONLY MOD: 02 04 RG 2,21KOHM+-1%TK100 1206 RESISTOR CHIP	RG 0007.5743.00	ROEDERSTEI	DC2 2,21KOHM 1%TK100	
R212	NUR VAR/ONLY MOD: 03 06 RG 10,OKOHM+-1%TK100 1206 RG CHIP RESISTOR	RG 0007.0793.00	ROEDERSTEI	DC2 10,OKOHM 1%TK100	
R213	RG 10,OKOHM+-1%TK100 1206 RG CHIP RESISTOR	RG 0007.0793.00	ROEDERSTEI	DC2 10,OKOHM 1%TK100	
R214	RG 3,32KOHM+-1%TK100 1206 RESISTOR CHIP	RG 0007.5789.00	ROEDERSTEI	DC2 3,32KOHM 1%TK100	
R215	RG 20,OKOHM+-1%TK100 1206 RESISTOR CHIP	RG 0007.5866.00	ROEDERSTEI	DC2 20,OKOHM 1%TK100	
R216	RG 20,OKOHM+-1%TK100 1206 RESISTOR CHIP NICHT BESTUECKT NOT FITTED	RG 0007.5866.00	ROEDERSTEI	DC2 20,OKOHM 1%TK100	
R218	RG 1,0 KO +-1%TK100 1206 CHIP RESISTOR	RG 0006.7271.00	ROEDERSTEI	DC2 1,OKOHM 1%TK100	

MENP5	413 3PUA	Äi	Datum Date	Schaltteilliste für Parts list for	Sachnummer Stock No.	Blatt-Nr. Page
		28	16.09.97	EE AUSGANGSTEIL 2.08GHZ OUTPUT UNIT 2.08GHZ	1062.7005.01 SA	14+

Für diese Unterlage behalten wir uns alle Rechte vor.

Kennz. Comp. No.	Benennung Designation	Sachnummer Stock No.	Hersteller Manufacturer	Bezeichnung Designation	enthalten in contained in
R220	RG 100 OHM+-1%TK100 1206 CHIP RESISTOR	RG 0006.8884.00	ROEDERSTEI	DC2 100OHM 1%TK100	
R221	RG 182 KOHM+-1%TK100 1206 RESISTOR CHIP NICHT BESTUECKT NOT FITTED	RG 0007.5989.00	ROEDERSTEI	DC2 182KOHM 1%TK100	
R240	RG 10,0KOHM+-1%TK100 1206 RG CHIP RESISTOR	RG 0007.0793.00	ROEDERSTEI	DC2 10,0KOHM 1%TK100	
R241	RG 20,0KOHM+-1%TK100 1206 RESISTOR CHIP	RG 0007.5866.00	ROEDERSTEI	DC2 20,0KOHM 1%TK100	
R259	RG 221 KOHM+-1%TK100 1206 RESISTOR CHIP NUR VAR/ONLY MOD: 02 04	RG 0007.6004.00	ROEDERSTEI	DC2 221KOHM 1%TK100	
R259	RG 56,2KOHM+-1%TK100 1206 CHIP RESISTOR NUR VAR/ONLY MOD: 03 06	RG 0007.1883.00	ROEDERSTEI	DC2 56,2KOHM 1%TK100	
R271	RG 10,0KOHM+-1%TK100 1206 RG CHIP RESISTOR	RG 0007.0793.00	ROEDERSTEI	DC2 10,0KOHM 1%TK100	
R272	RG 10,0KOHM+-1%TK100 1206 RG CHIP RESISTOR	RG 0007.0793.00	ROEDERSTEI	DC2 10,0KOHM 1%TK100	
R275	RG 1,0 KO +-1%TK100 1206 CHIP RESISTOR	RG 0006.7271.00	ROEDERSTEI	DC2 1,0KOHM 1%TK100	
R276	RG 10,0KOHM+-1%TK100 1206 RG CHIP RESISTOR	RG 0007.0793.00	ROEDERSTEI	DC2 10,0KOHM 1%TK100	
R278	RG 47,5KOHM+-1%TK100 1206 RESISTOR CHIP NUR VAR/ONLY MOD: 02	RG 0007.5950.00	ROEDERSTEI	DC2 47,5KOHM 1%TK100	
R278	RG 30,1KOHM+-1%TK100 1206 RESISTOR CHIP NUR VAR/ONLY MOD: 03 04 06	RG 0007.5908.00	ROEDERSTEI	DC2 30,1KOHM 1%TK100	
R280	RS 0,25W 5KOHM +-20% SMD POTENTIOMETER	RS 0007.9632.00	SIEMENS	S4G-5KOHM	
R283 ..285	RG 20,0KOHM+-1%TK100 1206 RESISTOR CHIP	RG 0007.5866.00	ROEDERSTEI	DC2 20,0KOHM 1%TK100	
R286	RG 10,0KOHM+-1%TK100 1206 RG CHIP RESISTOR	RG 0007.0793.00	ROEDERSTEI	DC2 10,0KOHM 1%TK100	
R299	RG 33,2KOHM+-1%TK100 1206 RESISTOR CHIP NUR VAR/ONLY MOD: 02 04	RG 0007.5914.00	ROEDERSTEI	DC2 33,2KOHM 1%TK100	
R299	RG 15,0KOHM+-1%TK100 1206 RESISTOR CHIP NUR VAR/ONLY MOD: 03 06	RG 0007.5843.00	ROEDERSTEI	DC2 15,0KOHM 1%TK100	
R300	RG 0,05W 22R +-1% 0805 RESISTOR	RG 0007.8920.00	HONEST JAP	MR 08 M 22R 1% 0805	
R301 ..308	RK SMD-HEISSL.220R 0805 SMD-NTC-RESISTOR	1039.1310.00	SIEMENS	B57620-C221-K62	
R310	RG 68,1 OHM+-1%TK100 1206 CHIP RESISTOR	RG 0006.8849.00	ROEDERSTEI	DC2 68,1OHM 1%TK100	
R312	RG 12,1 OHM+-1%TK100 1206 CHIP RESISTOR	RG 0006.8661.00	ROEDERSTEI	DC2 12,1OHM 1%TK100	
R313	RG 56,2 OHM+-1%TK100 1206 CHIP RESISTOR	RG 0006.8826.00	ROEDERSTEI	DC2 56,2OHM 1%TK100	
R314	RG 511 OHM+-1%TK100 1206 CHIP RESISTOR	RG 0006.9051.00	ROEDERSTEI	DC2 511OHM 1%TK100	
R315	RL 0,60W 1,33KOHM+-1%TK50 RESISTOR	RL 0083.0684.00	RESISTA	MK2	
R316	RG 39,2 OHM+-1%TK100 1206 RESISTOR CHIP	RG 0007.5543.00	ROEDERSTEI	DC2 39,2OHM 1%TK100	
R317	RL 0,60W 1,33KOHM+-1%TK50 RESISTOR	RL 0083.0684.00	RESISTA	MK2	
R318	RL 0,60W 1,33KOHM+-1%TK50 RESISTOR	RL 0083.0684.00	RESISTA	MK2	
R319	RG 562 OHM+-1%TK100 1206 CHIP RESISTOR	RG 0006.9068.00	ROEDERSTEI	DC2 562OHM 1%TK100	
R320	RG 15,0 OHM+-1%TK100 1206 RESISTOR CHIP	RG 0007.5450.00	ROEDERSTEI	DC2 15,0OHM 1%TK100	
R321	RG 15,0 OHM+-1%TK100 1206 RESISTOR CHIP	RG 0007.5450.00	ROEDERSTEI	DC2 15,0OHM 1%TK100	
R325	RG 2,0 KOHM+-1%TK100 1206 RESISTOR CHIP	RG 0007.5737.00	ROEDERSTEI	DC2 2,0KOHM 1%TK100	
R327	RG 562 OHM+-1%TK100 1206 CHIP RESISTOR	RG 0006.9068.00	ROEDERSTEI	DC2 562OHM 1%TK100	
R328	RG 56,2 OHM+-1%TK100 1206 CHIP RESISTOR	RG 0006.8826.00	ROEDERSTEI	DC2 56,2OHM 1%TK100	
R329	RL 0,60W 1,33KOHM+-1%TK50 RESISTOR	RL 0083.0684.00	RESISTA	MK2	
R330	RG 15,0 OHM+-1%TK100 1206 RESISTOR CHIP	RG 0007.5450.00	ROEDERSTEI	DC2 15,0OHM 1%TK100	

095.0028-0693



ROHDE & SCHWARZ

28

16.09.97

EE AUSGANGSTEIL 2.08GHZ
OUTPUT UNIT 2.08GHZ

1062.7005.01 SA

15+

Für diese Untertafel behalten wir uns alle Rechte vor.

Kennz. Comp. No.	Benennung Designation	Sachnummer Stock No.	Hersteller Manufacturer	Bezeichnung Designation	enthalten in contained in
R332	RL 0,60W 1,33KOHM+-1%TK50 RESISTOR	RL 0083.0684.00	RESISTA	MK2	
R333	RG 15,0 OHM+-1%TK100 1206 RESISTOR CHIP	RG 0007.5450.00	ROEDERSTEI	DC2 15,0OHM 1%TK100	
R340	RG 511 OHM+-1%TK100 1206 CHIP RESISTOR	RG 0006.9051.00	ROEDERSTEI	DC2 511OHM 1%TK100	
R341	RL 0,60W 1,33KOHM+-1%TK50 RESISTOR	RL 0083.0684.00	RESISTA	MK2	
R342	RG 39,2 OHM+-1%TK100 1206 RESISTOR CHIP	RG 0007.5543.00	ROEDERSTEI	DC2 39,2OHM 1%TK100	
R355	RG 0-OHM WIDERSTAND-CHIP RESISTOR CHIP 0-OHM	RG 0007.5108.00	DRALORIC	CR 1206	
R356	RL 0,60W 100 OHM+-1%TK50 RESISTOR NICHT BESTUECKT NOT FITTED	RL 0082.6543.00	RESISTA	MK2	
R357	RL 0,60W 100 OHM+-1%TK50 RESISTOR NICHT BESTUECKT NOT FITTED	RL 0082.6543.00	RESISTA	MK2	
R360	RL 0,60W 100 OHM+-1%TK50 RESISTOR	RL 0082.6543.00	RESISTA	MK2	
R361	RL 0,60W 100 OHM+-1%TK50 RESISTOR	RL 0082.6543.00	RESISTA	MK2	
R400	RG 511 OHM+-1%TK100 1206 CHIP RESISTOR	RG 0006.9051.00	ROEDERSTEI	DC2 511OHM 1%TK100	
R401	RL 0,60W 1,33KOHM+-1%TK50 RESISTOR	RL 0083.0684.00	RESISTA	MK2	
R402	RG 39,2 OHM+-1%TK100 1206 RESISTOR CHIP	RG 0007.5543.00	ROEDERSTEI	DC2 39,2OHM 1%TK100	
R404	RG 56,2 OHM+-1%TK100 1206 CHIP RESISTOR	RG 0006.8826.00	ROEDERSTEI	DC2 56,2OHM 1%TK100	
R405	RG 562 OHM+-1%TK100 1206 CHIP RESISTOR	RG 0006.9068.00	ROEDERSTEI	DC2 562OHM 1%TK100	
R406	RG 15,0 OHM+-1%TK100 1206 RESISTOR CHIP	RG 0007.5450.00	ROEDERSTEI	DC2 15,0OHM 1%TK100	
R407	RG 15,0 OHM+-1%TK100 1206 RESISTOR CHIP	RG 0007.5450.00	ROEDERSTEI	DC2 15,0OHM 1%TK100	
R408	RL 0,60W 1,33KOHM+-1%TK50 RESISTOR	RL 0083.0684.00	RESISTA	MK2	
R409	RL 0,60W 1,33KOHM+-1%TK50 RESISTOR	RL 0083.0684.00	RESISTA	MK2	
R410	RG 39,2KOHM+-1%TK100 1206 RESISTOR CHIP	RG 0007.5937.00	ROEDERSTEI	DC2 39,2KOHM 1%TK100	
R411	RG 1,5 KOHM+-1%TK100 1206 RESISTOR CHIP	RG 0007.5714.00	ROEDERSTEI	DC2 1,5KOHM 1%TK100	
R412	RG 1,0 KO +-1%TK100 1206 CHIP RESISTOR	RG 0006.7271.00	ROEDERSTEI	DC2 1,0KOHM 1%TK100	
R416	RL 0,60W 100 OHM+-1%TK50 RESISTOR	RL 0082.6543.00	RESISTA	MK2	
R417	RL 0,60W 100 OHM+-1%TK50 RESISTOR	RL 0082.6543.00	RESISTA	MK2	
R431	RG 10,0KOHM+-1%TK100 1206	RG 0007.0793.00	ROEDERSTEI	DC2 10,0KOHM 1%TK100	
..438	RG CHIP RESISTOR				
R440	RG 10,0KOHM+-1%TK100 1206	RG 0007.0793.00	ROEDERSTEI	DC2 10,0KOHM 1%TK100	
R442	RG 10,0KOHM+-1%TK100 1206	RG 0007.0793.00	ROEDERSTEI	DC2 10,0KOHM 1%TK100	
R443	RG 10,0KOHM+-1%TK100 1206	RG 0007.0793.00	ROEDERSTEI	DC2 10,0KOHM 1%TK100	
R450	RG 100 OHM+-1%TK100 1206	RG 0006.8884.00	ROEDERSTEI	DC2 100OHM 1%TK100	
R451	RG 150 OHM+-1%TK100 1206	RG 0007.5589.00	ROEDERSTEI	DC2 150OHM 1%TK100	
R452	RG 182 OHM+-1%TK100 1206	RG 0007.5595.00	ROEDERSTEI	DC2 182OHM 1%TK100	
R453	RG 150 OHM+-1%TK100 1206	RG 0007.5589.00	ROEDERSTEI	DC2 150OHM 1%TK100	
R454	RG 100 OHM+-1%TK100 1206	RG 0006.8884.00	ROEDERSTEI	DC2 100OHM 1%TK100	
R455	RG 56,2 OHM+-1%TK100 1206	RG 0006.8826.00	ROEDERSTEI	DC2 56,2OHM 1%TK100	
R500	RG 2,0 KOHM+-1%TK100 1206	RG 0007.5737.00	ROEDERSTEI	DC2 2,0KOHM 1%TK100	
..502	RESISTOR CHIP				
R503	RG 392 OHM+-1%TK100 1206	RG 0007.5672.00	ROEDERSTEI	DC2 392OHM 1%TK100	
R520	RG 1,21KOHM+-1%TK100 1206	RG 0006.9968.00	ROEDERSTEI	DC2 1,21KOHM 1%TK100	
..522	CHIP RESISTOR				

MENPS	413 3PUA	Ät	Datum Date	Schaltteilliste für Parts list for	Sachnummer Stock No.	Blatt-Nr. Page
	28	16.09.97	EE AUSGANGSTEIL 2.08GHZ OUTPUT UNIT 2.08GHZ	1062.7005.01 SA	16+	

095.0026-0693

Für diese Unterlage behalten
wir uns alle Rechte vor.

Kennz. Comp. No.	Benennung Designation	Sachnummer Stock No.	Hersteller Manufacturer	Bezeichnung Designation	enthalten in contained in
R530	RG 392 OHM+-1%TK100 1206 RESISTOR CHIP	RG 0007.5672.00	ROEDERSTEI	DC2 392OHM 1%TK100	
R600	RG 221 OHM+-1%TK100 1206 RESISTOR CHIP	RG 0007.5614.00	ROEDERSTEI	DC2 221OHM 1%TK100	
R601	RL 0,60W 274 OHM+-1%TK50 RESISTOR	RL 0083.0178.00	RESISTA	MK2	
R602	RG 27,4 OHM+-1%TK100 1206 RESISTOR CHIP	RG 0007.5508.00	ROEDERSTEI	DC2 27,4OHM 1%TK100	
R603	RG 33,2 OHM+-1%TK100 1206 RESISTOR CHIP	RG 0007.5520.00	ROEDERSTEI	DC2 33,2OHM 1%TK100	
R604	RG 68,1 OHM+-1%TK100 1206 CHIP RESISTOR	RG 0006.8849.00	ROEDERSTEI	DC2 68,1OHM 1%TK100	
R605	RG 15,0 OHM+-1%TK100 1206 RESISTOR CHIP	RG 0007.5450.00	ROEDERSTEI	DC2 15,0OHM 1%TK100	
R607	RG 825 KOHM+-1%TK100 1206 RESISTOR CHIP	RG 0007.6133.00	ROEDERSTEI	DC2 825KOHM 1%TK100	
R608	RG 100 OHM+-1%TK100 1206 CHIP RESISTOR	RG 0006.8884.00	ROEDERSTEI	DC2 100OHM 1%TK100	
R609	RG 1,5 KOHM+-1%TK100 1206 RESISTOR CHIP	RG 0007.5714.00	ROEDERSTEI	DC2 1,5KOHM 1%TK100	
R611	RG 392 OHM+-1%TK100 1206 RESISTOR CHIP	RG 0007.5672.00	ROEDERSTEI	DC2 392OHM 1%TK100	
R612	RG 475 OHM+-1%TK100 1206 RESISTOR CHIP	RG 0007.5695.00	ROEDERSTEI	DC2 475OHM 1%TK100	
R613	RG 3,57KOHM+-1%TK100 1206 RESISTOR CHIP	RG 0007.5795.00	ROEDERSTEI	DC2 3,57KOHM 1%TK100	
R614	RG 2,74KOHM+-1%TK100 1206 RESISTOR CHIP	RG 0007.5766.00	ROEDERSTEI	DC2 2,74KOHM 1%TK100	
R615	RG 1,2MOHM+-5%TK200 1206 CHIP RESISTOR NICHT BESTUECKT NOT FITTED	0007.9949.00	ROEDERSTEI	D 25	
R616	RG 3,57KOHM+-1%TK100 1206 RESISTOR CHIP	RG 0007.5795.00	ROEDERSTEI	DC2 3,57KOHM 1%TK100	
R618	RG 100,0KOH+-1%TK100 1206 CHIP RESISTOR	RG 0007.1948.00	ROEDERSTEI	DC2 100KOHM 1%TK100	
R619	RS 0,25W 5KOHM +-20% SMD POTENTIOMETER	RS 0007.9632.00	SIEMENS	S4G-5KOHM	
R620	RG 100,0KOH+-1%TK100 1206 CHIP RESISTOR	RG 0007.1948.00	ROEDERSTEI	DC2 100KOHM 1%TK100	
R621	RG 475 OHM+-1%TK100 1206 RESISTOR CHIP	RG 0007.5695.00	ROEDERSTEI	DC2 475OHM 1%TK100	
R622	RG 100 OHM+-1%TK100 1206 CHIP RESISTOR	RG 0006.8884.00	ROEDERSTEI	DC2 100OHM 1%TK100	
R623	RK SMD-HEISSEL.220R 0805 SMD-NTC-RESISTOR NICHT BESTUECKT NOT FITTED	1039.1310.00	SIEMENS	B57620-C221-K62	
R624	RK SMD-HEISSEL.220R 0805 SMD-NTC-RESISTOR	1039.1310.00	SIEMENS	B57620-C221-K62	
R625	RG 27,4 OHM+-1%TK100 1206 RESISTOR CHIP	RG 0007.5508.00	ROEDERSTEI	DC2 27,4OHM 1%TK100	
R626	RG 100 OHM+-1%TK100 1206 CHIP RESISTOR	RG 0006.8884.00	ROEDERSTEI	DC2 100OHM 1%TK100	
R627	RG 56,2 OHM+-1%TK100 1206 CHIP RESISTOR	RG 0006.8826.00	ROEDERSTEI	DC2 56,2OHM 1%TK100	
R628	RG 100 OHM+-1%TK100 1206 CHIP RESISTOR	RG 0006.8884.00	ROEDERSTEI	DC2 100OHM 1%TK100	
R629	RG 100 OHM+-1%TK100 1206 CHIP RESISTOR	RG 0006.8884.00	ROEDERSTEI	DC2 100OHM 1%TK100	
R630	RG 825 OHM+-1%TK100 1206 CHIP RESISTOR	RG 0006.7259.00	ROEDERSTEI	DC2 825OHM 1%TK100	
R631	RG 825 OHM+-1%TK100 1206 CHIP RESISTOR	RG 0006.7259.00	ROEDERSTEI	DC2 825OHM 1%TK100	
R632	RG 0-OHM WIDERSTAND-CHIP RESISTOR CHIP 0-OHM	RG 0007.5108.00	DRALORIC	CR 1206	
R633	RG 2,74KOHM+-1%TK100 1206 RESISTOR CHIP	RG 0007.5766.00	ROEDERSTEI	DC2 2,74KOHM 1%TK100	
R634	RG 5,62OHM+-1%TK100 1206 CHIP-RESISTOR	RG 0007.8442.00	PHILIPS	RC 02	
R635	RG 22,1KOHM+-1%TK100 1206 RESISTOR CHIP	RG 0007.5872.00	ROEDERSTEI	DC2 22,1KOHM 1%TK100	
R636	RG 10,0KOHM+-1%TK100 1206 RG CHIP RESISTOR	RG 0007.0793.00	ROEDERSTEI	DC2 10,0KOHM 1%TK100	
R637	RG 1,5 KOHM+-1%TK100 1206 RESISTOR CHIP	RG 0007.5714.00	ROEDERSTEI	DC2 1,5KOHM 1%TK100	
R638	RG 392 OHM+-1%TK100 1206 RESISTOR CHIP	RG 0007.5672.00	ROEDERSTEI	DC2 392OHM 1%TK100	

MENP5

413 3PUA

Äl

Datum
Date

Schalttailliste für
Parts list for

Sachnummer
Stock No.

Blatt-Nr.
Page



ROHDE & SCHWARZ

28

16.09.97

EE AUSGANGSTEIL 2.08GHZ

OUTPUT UNIT 2.08GHZ

1062.7005.01 SA

17+

Kannz. Comp. No.	Benennung Designation	Sachnummer Stock No.	Hersteller Manufacturer	Bezeichnung Designation	enthalten in contained in
R639	RG 10,0KOHM+-1%TK100 1206 RG CHIP RESISTOR	RG 0007.0793.00	ROEDERSTEI	DC2 10,0KOHM 1%TK100	
R640	RG 0-OHM WIDERSTAND-CHIP RESISTOR CHIP 0-OHM	RG 0007.5108.00	DRALORIC	CR 1206	
R641	RG 0-OHM WIDERSTAND-CHIP RESISTOR CHIP 0-OHM	RG 0007.5108.00	DRALORIC	CR 1206	
R642	RG 51,1 OHM+-1%TK100 1206 CHIP RESISTOR	RG 0006.8810.00	RESISTA	DC2 51,10HM 1%TK100	
R644	RG 475 OHM+-1%TK100 1206 RESISTOR CHIP	RG 0007.5695.00	ROEDERSTEI	DC2 475OHM 1%TK100	
R645	RS 0,25W200 OHM+-20% SMD POTENTIOMETER	RS 0007.9590.00	SIEMENS	S4G-200 OHM	
R646	RL 0,60W 182 OHM+-1%TK50 RESISTOR	RL 0083.0010.00	RESISTA	MK2	
R647	RL 0,60W 121 OHM+-1%TK50 RESISTOR	RL 0082.9859.00	RESISTA	MK2	
R648	RG 100 OHM+-1%TK100 1206 CHIP RESISTOR	RG 0006.8884.00	ROEDERSTEI	DC2 100OHM 1%TK100	
R649	RG 2,74OHM+-1%TK100 1206 CHIP-RESISTOR	RG 0007.8365.00	PHILIPS	RC 02	
R650	RL 0,60W 1,33KOHM+-1%TK50 RESISTOR	RL 0083.0684.00	RESISTA	MK2	
R651	RG 1,0MOHM+-1%TK100 1206 CHIP RESISTOR	RG 0815.7532.00	DRALORIC	CRC 1206	
R652	RG 68,1 OHM+-1%TK100 1206 CHIP RESISTOR	RG 0006.8849.00	ROEDERSTEI	DC2 68,10HM 1%TK100	
R653	RG 56,2 OHM+-1%TK100 1206 CHIP RESISTOR	RG 0006.8826.00	ROEDERSTEI	DC2 56,20HM 1%TK100	
R654	RG 56,2 OHM+-1%TK100 1206 CHIP RESISTOR	RG 0006.8826.00	ROEDERSTEI	DC2 56,20HM 1%TK100	
R655	RG 2,21OHM+-1%TK100 1206 CHIP-RESISTOR	RG 0007.8342.00	PHILIPS	RC 02	
R656	RL 0,60W 1,33KOHM+-1%TK50 RESISTOR	RL 0083.0684.00	RESISTA	MK2	
R657	RG 10,0KOHM+-1%TK100 1206 RG CHIP RESISTOR	RG 0007.0793.00	ROEDERSTEI	DC2 10,0KOHM 1%TK100	
R658	RG 10,0KOHM+-1%TK100 1206 RG CHIP RESISTOR	RG 0007.0793.00	ROEDERSTEI	DC2 10,0KOHM 1%TK100	
R659	RG 511 OHM+-1%TK100 1206 CHIP RESISTOR	RG 0006.9051.00	ROEDERSTEI	DC2 511OHM 1%TK100	
R660	RG 681 KOHM+-1%TK100 1206 RESISTOR CHIP	RG 0007.6110.00	ROEDERSTEI	DC2 681KOHM 1%TK100	
R661	RG 0-OHM WIDERSTAND-CHIP RESISTOR CHIP 0-OHM	RG 0007.5108.00	DRALORIC	CR 1206	
R662	RG 0-OHM WIDERSTAND-CHIP RESISTOR CHIP 0-OHM	RG 0007.5108.00	DRALORIC	CR 1206	
R663	RG 0-OHM WIDERSTAND-CHIP RESISTOR CHIP 0-OHM NICHT BESTUECKT NOT FITTED	RG 0007.5108.00	DRALORIC	CR 1206	
R670	RL 0,60W 100 OHM+-1%TK50 RESISTOR NICHT BESTUECKT NOT FITTED	RL 0082.6543.00	RESISTA	MK2	
R671	RL 0,60W 100 OHM+-1%TK50 RESISTOR NICHT BESTUECKT NOT FITTED	RL 0082.6543.00	RESISTA	MK2	
R672	RL 0,60W 100 OHM+-1%TK50 RESISTOR	RL 0082.6543.00	RESISTA	MK2	
R673	RL 0,60W 100 OHM+-1%TK50 RESISTOR	RL 0082.6543.00	RESISTA	MK2	
R674	RG 825 OHM+-1%TK100 1206 CHIP RESISTOR	RG 0006.7259.00	ROEDERSTEI	DC2 825OHM 1%TK100	
R675	RG 825 OHM+-1%TK100 1206 CHIP RESISTOR	RG 0006.7259.00	ROEDERSTEI	DC2 825OHM 1%TK100	
R676	RG 5,62OHM+-1%TK100 1206 CHIP-RESISTOR	RG 0007.8442.00	PHILIPS	RC 02	
R677	RG 825 OHM+-1%TK100 1206 CHIP RESISTOR	RG 0006.7259.00	ROEDERSTEI	DC2 825OHM 1%TK100	
R678	RG 825 OHM+-1%TK100 1206 CHIP RESISTOR	RG 0006.7259.00	ROEDERSTEI	DC2 825OHM 1%TK100	
R679	RG 5,62OHM+-1%TK100 1206 CHIP-RESISTOR	RG 0007.8442.00	PHILIPS	RC 02	
R680	RL 0,60W 100 OHM+-1%TK50 RESISTOR	RL 0082.6543.00	RESISTA	MK2	
R681	RL 0,60W 100 OHM+-1%TK50 RESISTOR	RL 0082.6543.00	RESISTA	MK2	

Für diese Unterlage behalten wir uns alle Rechte vor.

MENP5	413 3PUA	Äl	Datum Date	Schaltteillista für Parts list for	Sachnummer Stock No.	Blatt-Nr. Page
	28	16.09.97	EE AUSGANGSTEIL 2.08GHZ OUTPUT UNIT 2.08GHZ	1062.7005.01 SA	18+	

095.0026-0893

Für diese Unterlage behalten
wir uns alle Rechte vor.

Kennz. Comp. No.	Benennung Designation	Sachnummer Stock No.	Hersteller Manufacturer	Bezeichnung Designation	enthalten in contained in
R682	RG 82,5 OHM+-1%TK100 1206 CHIP RESISTOR	RG 0006.8861.00	ROEDERSTEI	DC2 82,5OHM 1%TK100	
R683	RG 1,0 KO +-1%TK100 1206 CHIP RESISTOR	RG 0006.7271.00	ROEDERSTEI	DC2 1,0KOHM 1%TK100	
R684	RG 475 KOHM+-1%TK100 1206 RESISTOR CHIP	RG 0007.6079.00	ROEDERSTEI	DC2 475KOHM 1%TK100	
R685	RG 1,0 KO +-1%TK100 1206 CHIP RESISTOR	RG 0006.7271.00	ROEDERSTEI	DC2 1,0KOHM 1%TK100	
R686	RG 1,0MOHM+-1%TK100 1206 CHIP RESISTOR	RG 0815.7532.00	DRALORIC	CRC 1206	
R687	RG 511 OHM+-1%TK100 1206 CHIP RESISTOR	RG 0006.9051.00	ROEDERSTEI	DC2 511OHM 1%TK100	
R688	RL 0,60W 1,33KOHM+-1%TK50 RESISTOR	RL 0083.0684.00	RESISTA	MK2	
R689	RG 39,2 OHM+-1%TK100 1206 RESISTOR CHIP	RG 0007.5543.00	ROEDERSTEI	DC2 39,2OHM 1%TK100	
R690	RL 0,60W 1,33KOHM+-1%TK50 RESISTOR	RL 0083.0684.00	RESISTA	MK2	
R691	RL 0,60W 1,33KOHM+-1%TK50 RESISTOR	RL 0083.0684.00	RESISTA	MK2	
R692	RG 56,2 OHM+-1%TK100 1206 CHIP RESISTOR	RG 0006.8826.00	ROEDERSTEI	DC2 56,2OHM 1%TK100	
R693	RG 56,2 OHM+-1%TK100 1206 CHIP RESISTOR	RG 0006.8826.00	ROEDERSTEI	DC2 56,2OHM 1%TK100	
R694	RG 15,0 OHM+-1%TK100 1206 RESISTOR CHIP	RG 0007.5450.00	ROEDERSTEI	DC2 15,0OHM 1%TK100	
.697 R698	RG 562 OHM+-1%TK100 1206 CHIP RESISTOR	RG 0006.9068.00	ROEDERSTEI	DC2 562OHM 1%TK100	
R699	RG 56,2 OHM+-1%TK100 1206 CHIP RESISTOR	RG 0006.8826.00	ROEDERSTEI	DC2 56,2OHM 1%TK100	
R700	RG 82,5 OHM+-1%TK100 1206 CHIP RESISTOR	RG 0006.8861.00	ROEDERSTEI	DC2 82,5OHM 1%TK100	
R701	RG 1,0 KO +-1%TK100 1206 CHIP RESISTOR	RG 0006.7271.00	ROEDERSTEI	DC2 1,0KOHM 1%TK100	
R702	RG 475 KOHM+-1%TK100 1206 RESISTOR CHIP	RG 0007.6079.00	ROEDERSTEI	DC2 475KOHM 1%TK100	
R703	RG 10,0KOHM+-1%TK100 1206 RG CHIP RESISTOR	RG 0007.0793.00	ROEDERSTEI	DC2 10,0KOHM 1%TK100	
R704	RG 1,0 KO +-1%TK100 1206 CHIP RESISTOR	RG 0006.7271.00	ROEDERSTEI	DC2 1,0KOHM 1%TK100	
R705	RG 1,0MOHM+-1%TK100 1206 CHIP RESISTOR	RG 0815.7532.00	DRALORIC	CRC 1206	
R706	RG 1,21KOHM+-1%TK100 1206 CHIP RESISTOR	RG 0006.9968.00	ROEDERSTEI	DC2 1,21KOHM 1%TK100	
R707	RG 1,21KOHM+-1%TK100 1206 CHIP RESISTOR	RG 0006.9968.00	ROEDERSTEI	DC2 1,21KOHM 1%TK100	
R708	RG 0-OHM WIDERSTAND-CHIP RESISTOR CHIP 0-OHM	RG 0007.5108.00	DRALORIC	CR 1206	
R709	RG 100 OHM+-1%TK100 1206 CHIP RESISTOR	RG 0006.8884.00	ROEDERSTEI	DC2 100OHM 1%TK100	
R710	RG 121 OHM+-1%TK100 1206 CHIP RESISTOR	RG 0006.8903.00	ROEDERSTEI	DC2 121OHM 1%TK100	
R720	RG 100 OHM+-1%TK100 1206 CHIP RESISTOR	RG 0006.8884.00	ROEDERSTEI	DC2 100OHM 1%TK100	
R721	RG 121 OHM+-1%TK100 1206 CHIP RESISTOR	RG 0006.8903.00	ROEDERSTEI	DC2 121OHM 1%TK100	
R723	RG 1,21KOHM+-1%TK100 1206 CHIP RESISTOR	RG 0006.9968.00	ROEDERSTEI	DC2 1,21KOHM 1%TK100	
R724	RG 1,21KOHM+-1%TK100 1206 CHIP RESISTOR	RG 0006.9968.00	ROEDERSTEI	DC2 1,21KOHM 1%TK100	
R725	RG 475 OHM+-1%TK100 1206 RESISTOR CHIP	RG 0007.5695.00	ROEDERSTEI	DC2 475OHM 1%TK100	
R726	RG 475 OHM+-1%TK100 1206 RESISTOR CHIP	RG 0007.5695.00	ROEDERSTEI	DC2 475OHM 1%TK100	
R727	RG 332 OHM+-1%TK100 1206 RESISTOR CHIP	RG 0007.5650.00	ROEDERSTEI	DC2 332OHM 1%TK100	
R728	RG 332 OHM+-1%TK100 1206 RESISTOR CHIP	RG 0007.5650.00	ROEDERSTEI	DC2 332OHM 1%TK100	
R730	RG 332 OHM+-1%TK100 1206 RESISTOR CHIP	RG 0007.5650.00	ROEDERSTEI	DC2 332OHM 1%TK100	
R731	RG 1,21KOHM+-1%TK100 1206 CHIP RESISTOR	RG 0006.9968.00	ROEDERSTEI	DC2 1,21KOHM 1%TK100	
R732	RG 1,21KOHM+-1%TK100 1206 CHIP RESISTOR	RG 0006.9968.00	ROEDERSTEI	DC2 1,21KOHM 1%TK100	
R733	RG 39,2 OHM+-1%TK100 1206 RESISTOR CHIP	RG 0007.5543.00	ROEDERSTEI	DC2 39,2OHM 1%TK100	
R734	RG 121 OHM+-1%TK100 1206 CHIP RESISTOR	RG 0006.8903.00	ROEDERSTEI	DC2 121OHM 1%TK100	

095.0026-0693

 **ROHDE & SCHWARZ**

MENP5	413 3PUA	Äi	Datum Date	Schaltteilliste für Parts list for	Sachnummer Stock No.	Blatt-Nr. Page
		28	16.09.97	EE AUSGANGSTEIL 2.08GHZ OUTPUT UNIT 2.08GHZ	1062.7005.01 SA	19+

Für diese Unterteile behalten wir uns alle Rechte vor.

Kennz. Comp. No.	Benennung Designation	Sachnummer Stock No.	Hersteller Manufacturer	Bezeichnung Designation	enthalten in contained in
R735	RG 100 OHM+-1%TK100 1206 CHIP RESISTOR	RG 0006.8884.00	ROEDERSTEI	DC2 100OHM 1%TK100	
R736	RG 8,25KOHM+-1%TK100 1206 CHIP RESISTOR	RG 0007.0770.00	ROEDERSTEI	DC2 8,25KOHM 1%TK100	
R737	RG 8,25KOHM+-1%TK100 1206 CHIP RESISTOR	RG 0007.0770.00	ROEDERSTEI	DC2 8,25KOHM 1%TK100	
R738	RG 2,0 KOHM+-1%TK100 1206 RESISTOR CHIP	RG 0007.5737.00	ROEDERSTEI	DC2 2,0KOHM 1%TK100	
R739	RL 0,60W 1,33KOHM+-1%TK50 RESISTOR	RL 0083.0684.00	RESISTA	MK2	
R740	RG 0-OHM WIDERSTAND-CHIP RESISTOR CHIP 0-OHM	RG 0007.5108.00	DRALORIC	CR 1206	
R741	RG 68,1 OHM+-1%TK100 1206 CHIP RESISTOR NICHT BESTUECKT NOT FITTED	RG 0006.8849.00	ROEDERSTEI	DC2 68,1OHM 1%TK100	
R742	RG 68,1 OHM+-1%TK100 1206 CHIP RESISTOR NICHT BESTUECKT NOT FITTED	RG 0006.8849.00	ROEDERSTEI	DC2 68,1OHM 1%TK100	
R743	RG 68,1 OHM+-1%TK100 1206 CHIP RESISTOR NICHT BESTUECKT NOT FITTED	RG 0006.8849.00	ROEDERSTEI	DC2 68,1OHM 1%TK100	
R745	RG 10,0KOHM+-1%TK100 1206 RG CHIP RESISTOR	RG 0007.0793.00	ROEDERSTEI	DC2 10,0KOHM 1%TK100	
R747	RG 8,25KOHM+-1%TK100 1206 CHIP RESISTOR	RG 0007.0770.00	ROEDERSTEI	DC2 8,25KOHM 1%TK100	
R748	RG 8,25KOHM+-1%TK100 1206 CHIP RESISTOR	RG 0007.0770.00	ROEDERSTEI	DC2 8,25KOHM 1%TK100	
R750	RG 332 OHM+-1%TK100 1206 RESISTOR CHIP	RG 0007.5650.00	ROEDERSTEI	DC2 332OHM 1%TK100	
R751	RG 332 OHM+-1%TK100 1206 RESISTOR CHIP	RG 0007.5650.00	ROEDERSTEI	DC2 332OHM 1%TK100	
R753	RG 475 OHM+-1%TK100 1206 RESISTOR CHIP	RG 0007.5695.00	ROEDERSTEI	DC2 475OHM 1%TK100	
R754	RG 475 OHM+-1%TK100 1206 RESISTOR CHIP	RG 0007.5695.00	ROEDERSTEI	DC2 475OHM 1%TK100	
R755	RG 1,0 KO +-1%TK100 1206 CHIP RESISTOR	RG 0006.7271.00	ROEDERSTEI	DC2 1,0KOHM 1%TK100	
R760	RG 10,0KOHM+-1%TK100 1206 RG CHIP RESISTOR	RG 0007.0793.00	ROEDERSTEI	DC2 10,0KOHM 1%TK100	
R761	RG 0-OHM WIDERSTAND-CHIP RESISTOR CHIP 0-OHM	RG 0007.5108.00	DRALORIC	CR 1206	
R762	RG 47,5 OHM+-1%TK100 1206 RESISTOR CHIP	RG 0007.5566.00	ROEDERSTEI	DC2 47,5OHM 1%TK100	
R765	RG 3,92KOHM+-1%TK100 1206 RESISTOR CHIP	RG 0007.5808.00	RESISTA	DC2 3,92KOHM 1%TK100	
R766	RG 562 OHM+-1%TK100 1206 CHIP RESISTOR	RG 0006.9068.00	ROEDERSTEI	DC2 562OHM 1%TK100	
R767	RG 15,0 OHM+-1%TK100 1206 RESISTOR CHIP	RG 0007.5450.00	ROEDERSTEI	DC2 15,0OHM 1%TK100	
R768	RL 0,60W 1,33KOHM+-1%TK50 RESISTOR	RL 0083.0684.00	RESISTA	MK2	
R769	RG 56,2 OHM+-1%TK100 1206 CHIP RESISTOR	RG 0006.8826.00	ROEDERSTEI	DC2 56,2OHM 1%TK100	
R770	RL 0,60W 1,33KOHM+-1%TK50 RESISTOR	RL 0083.0684.00	RESISTA	MK2	
R771	RG 15,0 OHM+-1%TK100 1206 RESISTOR CHIP	RG 0007.5450.00	ROEDERSTEI	DC2 15,0OHM 1%TK100	
R772	RG 511 OHM+-1%TK100 1206 CHIP RESISTOR	RG 0006.9051.00	ROEDERSTEI	DC2 511OHM 1%TK100	
R773	RG 39,2 OHM+-1%TK100 1206 RESISTOR CHIP	RG 0007.5543.00	ROEDERSTEI	DC2 39,2OHM 1%TK100	
R774	RL 0,60W 1,33KOHM+-1%TK50 RESISTOR	RL 0083.0684.00	RESISTA	MK2	
R776	RL 0,60W 100 OHM+-1%TK50 RESISTOR	RL 0082.6543.00	RESISTA	MK2	
R777	RL 0,60W 100 OHM+-1%TK50 RESISTOR	RL 0082.6543.00	RESISTA	MK2	
R779	RG 332 OHM+-1%TK100 1206 RESISTOR CHIP	RG 0007.5650.00	ROEDERSTEI	DC2 332OHM 1%TK100	
R780	RG 332 OHM+-1%TK100 1206 RESISTOR CHIP	RG 0007.5650.00	ROEDERSTEI	DC2 332OHM 1%TK100	
R781	RG 150 OHM+-1%TK100 1206 RESISTOR CHIP	RG 0007.5589.00	ROEDERSTEI	DC2 150OHM 1%TK100	
R782	RG 150 OHM+-1%TK100 1206 RESISTOR CHIP	RG 0007.5589.00	ROEDERSTEI	DC2 150OHM 1%TK100	

MENP5	413 3PUA	Äl	Datum Date	Schaltteilliste für Parts list for	Sachnummer Stock No.	Blatt-Nr. Page
	28	16.09.97	EE AUSGANGSTEIL 2.08GHZ OUTPUT UNIT 2.08GHZ	1062.7005.01 SA	20+	

095.0028-0693

Für diese Unterlage behalten
wir uns alle Rechte vor.

Kennz. Comp. No.	Benennung Designation	Sachnummer Stock No.	Hersteller Manufacturer	Bezeichnung Designation	enthalten in contained in
R783	RG 47,5 OHM+-1%TK100 1206 RESISTOR CHIP	RG 0007.5566.00	ROEDERSTEI	DC2 47,5OHM 1%TK100	
R784	RG 47,5 OHM+-1%TK100 1206 RESISTOR CHIP	RG 0007.5566.00	ROEDERSTEI	DC2 47,5OHM 1%TK100	
R785 .790	RG 1,0 KO +-1%TK100 1206 CHIP RESISTOR	RG 0006.7271.00	ROEDERSTEI	DC2 1,0KOHM 1%TK100	
R791	RL 0,60W 100 OHM+-1%TK50 RESISTOR NICHT BESTUECKT NOT FITTED	RL 0082.6543.00	RESISTA	MK2	
R792	RL 0,60W 100 OHM+-1%TK50 RESISTOR NICHT BESTUECKT NOT FITTED	RL 0082.6543.00	RESISTA	MK2	
R793	RG 82,5KOHM+-1%TK100 1206 CHIP RESISTOR	RG 0007.1925.00	ROEDERSTEI	DC2 82,5KOHM 1%TK100	
R794	RG 12,1KOHM+-1%TK100 1206 CHIP RESISTOR	RG 0007.0841.00	ROEDERSTEI	DC2 12,1KOHM 1%TK100	
R800	RG 10,0KOHM+-1%TK100 1206 RG CHIP RESISTOR	RG 0007.0793.00	ROEDERSTEI	DC2 10,0KOHM 1%TK100	
R801	RG 10,0KOHM+-1%TK100 1206 RG CHIP RESISTOR	RG 0007.0793.00	ROEDERSTEI	DC2 10,0KOHM 1%TK100	
R802	RG 8,25KOHM+-1%TK100 1206 CHIP RESISTOR	RG 0007.0770.00	ROEDERSTEI	DC2 8,25KOHM 1%TK100	
R803	RG 8,25KOHM+-1%TK100 1206 CHIP RESISTOR	RG 0007.0770.00	ROEDERSTEI	DC2 8,25KOHM 1%TK100	
R804	RG 332 OHM+-1%TK100 1206 RESISTOR CHIP	RG 0007.5650.00	ROEDERSTEI	DC2 332OHM 1%TK100	
R805	RG 332 OHM+-1%TK100 1206 RESISTOR CHIP	RG 0007.5650.00	ROEDERSTEI	DC2 332OHM 1%TK100	
R806	RG 475 OHM+-1%TK100 1206 RESISTOR CHIP	RG 0007.5695.00	ROEDERSTEI	DC2 475OHM 1%TK100	
R807	RG 475 OHM+-1%TK100 1206 RESISTOR CHIP	RG 0007.5695.00	ROEDERSTEI	DC2 475OHM 1%TK100	
R808	RG 121 OHM+-1%TK100 1206 CHIP RESISTOR	RG 0006.8903.00	ROEDERSTEI	DC2 121OHM 1%TK100	
R809	RG 150 OHM+-1%TK100 1206 RESISTOR CHIP NICHT BESTUECKT NOT FITTED	RG 0007.5589.00	ROEDERSTEI	DC2 150OHM 1%TK100	
R810 .812	RG 68,1 OHM+-1%TK100 1206 CHIP RESISTOR	RG 0006.8849.00	ROEDERSTEI	DC2 68,1OHM 1%TK100	
R813	RG 0-OHM WIDERSTAND-CHIP RESISTOR CHIP 0-OHM	RG 0007.5108.00	DRALORIC	CR 1206	
R815	RG 0-OHM WIDERSTAND-CHIP RESISTOR CHIP 0-OHM	RG 0007.5108.00	DRALORIC	CR 1206	
R816	RG 33,2 OHM+-1%TK100 1206 RESISTOR CHIP	RG 0007.5520.00	ROEDERSTEI	DC2 33,2OHM 1%TK100	
R817	RG 150 OHM+-1%TK100 1206 RESISTOR CHIP NICHT BESTUECKT NOT FITTED	RG 0007.5589.00	ROEDERSTEI	DC2 150OHM 1%TK100	
R818	RG 22,1 OHM+-1%TK100 1206 RESISTOR CHIP	RG 0007.5489.00	ROEDERSTEI	DC2 22,1OHM 1%TK100	
R819	RG 1,0 KO +-1%TK100 1206 CHIP RESISTOR	RG 0006.7271.00	ROEDERSTEI	DC2 1,0KOHM 1%TK100	
R820	RG 10,0 OHM+-1%TK100 1206 CHIP -RESISTOR	RG 0006.8649.00	DRALORIC	CR(B) 1206...	
R821	RG 10,0KOHM+-1%TK100 1206 RG CHIP RESISTOR	RG 0007.0793.00	ROEDERSTEI	DC2 10,0KOHM 1%TK100	
R822	RG 3,16KOHM+-1%TK100 1206 CHIP RESISTOR	0007.0670.00	RESISTA	DC 2	
R823	RG 121 OHM+-1%TK100 1206 CHIP RESISTOR	RG 0006.8903.00	ROEDERSTEI	DC2 121OHM 1%TK100	
R824	RG 2,21KOHM+-1%TK100 1206 RESISTOR CHIP	RG 0007.5743.00	ROEDERSTEI	DC2 2,21KOHM 1%TK100	
R825	RG 221 OHM+-1%TK100 1206 RESISTOR CHIP	RG 0007.5614.00	ROEDERSTEI	DC2 221OHM 1%TK100	
R826	RG 18,2 OHM+-1%TK100 1206 RESISTOR CHIP	RG 0007.5466.00	ROEDERSTEI	DC2 18,2OHM 1%TK100	
R827	RG 47,5KOHM+-1%TK100 1206 RESISTOR CHIP	RG 0007.5950.00	ROEDERSTEI	DC2 47,5KOHM 1%TK100	
R828	RG 0-OHM WIDERSTAND-CHIP RESISTOR CHIP 0-OHM	RG 0007.5108.00	DRALORIC	CR 1206	
R829	RG 562 OHM+-1%TK100 1206 CHIP RESISTOR	RG 0006.9068.00	ROEDERSTEI	DC2 562OHM 1%TK100	
R830	RG 1,0 KO +-1%TK100 1206 CHIP RESISTOR	RG 0006.7271.00	ROEDERSTEI	DC2 1,0KOHM 1%TK100	

MENP5

413 3PUA

AI

Datum
Date

Schaltteilliste für
Parts list for

Sachnummer
Stock No.

Blatt-Nr.
Page



ROHDE & SCHWARZ

28 16.09.97

EE AUSGANGSTEIL 2.08GHZ
OUTPUT UNIT 2.08GHZ

1062.7005.01 SA

21+

Für diese Unterlage behalten wir uns alle Rechte vor.

Kennz. Comp. No.	Benennung Designation	Sachnummer Stock No.	Hersteller Manufacturer	Bezeichnung Designation	enthalten in contained in
R831	RG 10,0 OHM+-1%TK100 1206 CHIP -RESISTOR	RG 0006.8649.00	DRALORIC	CR(B) 1206...	
R832	RG 10,0KOHM+-1%TK100 1206 RG CHIP RESISTOR	RG 0007.0793.00	ROEDERSTEI	DC2 10,0KOHM 1%TK100	
R834	RG 3,16KOHM+-1%TK100 1206 CHIP RESISTOR	0007.0670.00	RESISTA	DC 2	
R835	RG 47,5KOHM+-1%TK100 1206 RESISTOR CHIP	RG 0007.5950.00	ROEDERSTEI	DC2 47,5KOHM 1%TK100	
R836	RG 2,21KOHM+-1%TK100 1206 RESISTOR CHIP	RG 0007.5743.00	ROEDERSTEI	DC2 2,21KOHM 1%TK100	
R837	RG 18,2 OHM+-1%TK100 1206 RESISTOR CHIP	RG 0007.5466.00	ROEDERSTEI	DC2 18,2OHM 1%TK100	
R838	RG 18,2 OHM+-1%TK100 1206 RESISTOR CHIP	RG 0007.5466.00	ROEDERSTEI	DC2 18,2OHM 1%TK100	
R839	RL 0,40W 820 OHM2% UNGEW. RESISTOR	RL 0092.6069.00	RESISTA	MK1 820OHM 2% UNG.	
R841	RG 0,05W 100R +-1% 0805 RESISTOR	RG 0007.9003.00	HONEST JAP	MR 08 M 100R 1% 0805	
R841	NUR VAR/ONLY MOD: 02 04 RG 0-OHM WIDERSTAND-CHIP RESISTOR CHIP 0-OHM	RG 0007.5108.00	DRALORIC	CR 1206	
R842	NUR VAR/ONLY MOD: 03 06 RG 0,05W 100R +-1% 0805 RESISTOR	RG 0007.9003.00	HONEST JAP	MR 08 M 100R 1% 0805	
R842	NUR VAR/ONLY MOD: 02 04 RG 0,05W 100R +-1% 0805 RESISTOR	RG 0007.9003.00	HONEST JAP	MR 08 M 100R 1% 0805	
R843	NUR VAR/ONLY MOD: 03 06 RG 10K +-1% TK200 0603 SMD-RESISTOR EIA0603	RG 0009.5357.00	DRALORIC	CR 0603 10K 1% TK200	
R844	RG 3,92KOHM+-1%TK100 1206 RESISTOR CHIP	RG 0007.5808.00	RESISTA	DC2 3,92KOHM 1%TK100	
R845	RG 3,92KOHM+-1%TK100 1206 RESISTOR CHIP	RG 0007.5808.00	RESISTA	DC2 3,92KOHM 1%TK100	
R846	RG 100 OHM+-1%TK100 1206 CHIP RESISTOR	RG 0006.8884.00	ROEDERSTEI	DC2 100OHM 1%TK100	
R847	RG 121 OHM+-1%TK100 1206 CHIP RESISTOR	RG 0006.8903.00	ROEDERSTEI	DC2 121OHM 1%TK100	
R848	RG 1,21KOHM+-1%TK100 1206 CHIP RESISTOR	RG 0006.9968.00	ROEDERSTEI	DC2 1,21KOHM 1%TK100	
R849	RG 47,5 OHM+-1%TK100 1206 RESISTOR CHIP NICHT BESTUECKT NOT FITTED	RG 0007.5566.00	ROEDERSTEI	DC2 47,5OHM 1%TK100	
R850	RG 100,0KOH+-1%TK100 1206 CHIP RESISTOR	RG 0007.1948.00	ROEDERSTEI	DC2 100KOHM 1%TK100	
R851	RS 0,25W 2KOHM +-20% SMD POTENTIOMETER	RS 0007.9626.00	SIEMENS	S4G-2KOHM	
R852	RG 100,0KOH+-1%TK100 1206 CHIP RESISTOR	RG 0007.1948.00	ROEDERSTEI	DC2 100KOHM 1%TK100	
R853	RG 39,2 OHM+-1%TK100 1206 RESISTOR CHIP	RG 0007.5543.00	ROEDERSTEI	DC2 39,2OHM 1%TK100	
R854	RG 1,0MOHM+-1%TK100 1206 CHIP RESISTOR NICHT BESTUECKT NOT FITTED	RG 0815.7532.00	DRALORIC	CRC 1206	
R855	RG 4,32KOHM+-1%TK100 1206 RESISTOR CHIP	RG 0007.5814.00	RESISTA	DC2 4,32KOHM 1%TK100	
R856	RG 3,32KOHM+-1%TK100 1206 RESISTOR CHIP	RG 0007.5789.00	ROEDERSTEI	DC2 3,32KOHM 1%TK100	
R857	RG 4,32KOHM+-1%TK100 1206 RESISTOR CHIP	RG 0007.5814.00	RESISTA	DC2 4,32KOHM 1%TK100	
R858	RG 56,2 OHM+-1%TK100 1206 CHIP RESISTOR	RG 0006.8826.00	ROEDERSTEI	DC2 56,2OHM 1%TK100	
R859	RG 56,2 OHM+-1%TK100 1206 CHIP RESISTOR	RG 0006.8826.00	ROEDERSTEI	DC2 56,2OHM 1%TK100	
R860	RG 0-OHM WIDERSTAND-CHIP RESISTOR CHIP 0-OHM	RG 0007.5108.00	DRALORIC	CR 1206	
R861	RG 475 OHM+-1%TK100 1206 RESISTOR CHIP	RG 0007.5695.00	ROEDERSTEI	DC2 475OHM 1%TK100	
R862	RG 3,32KOHM+-1%TK100 1206 RESISTOR CHIP	RG 0007.5789.00	ROEDERSTEI	DC2 3,32KOHM 1%TK100	
R863	RG 392 OHM+-1%TK100 1206 RESISTOR CHIP	RG 0007.5672.00	ROEDERSTEI	DC2 392OHM 1%TK100	
R866	RG 1,0MOHM+-1%TK100 1206 CHIP RESISTOR	RG 0815.7532.00	DRALORIC	CRC 1206	

MENP5	413 3PUA	Äi	Datum Date	Schaltteilliste für Parts list for	Sachnummer Stock No.	Blatt-Nr. Page
	28	16.09.97	EE AUSGANGSTEIL 2.08GHZ OUTPUT UNIT 2.08GHZ	1062.7005.01 SA	22+	

095.0028-0693

Für diese Unterlage behalten wir uns alle Rechte vor.

Kennz. Comp. No.	Benennung Designation	Sachnummer Stock No.	Hersteller Manufacturer	Bezeichnung Designation	enthalten in contained in
R867	RG 3,92KOHM+-1%TK100 1206 RESISTOR CHIP	RG 0007.5808.00	RESISTA	DC2 3,92KOHM 1%TK100	
R868	RG 681 KOHM+-1%TK100 1206 RESISTOR CHIP	RG 0007.6110.00	ROEDERSTEI	DC2 681KOHM 1%TK100	
R869	RG 825 KOHM+-1%TK100 1206 RESISTOR CHIP	RG 0007.6133.00	ROEDERSTEI	DC2 825KOHM 1%TK100	
R870	RG 22,1KOHM+-1%TK100 1206 RESISTOR CHIP	RG 0007.5872.00	ROEDERSTEI	DC2 22,1KOHM 1%TK100	
R871	RG 10,0KOHM+-1%TK100 1206 RG CHIP RESISTOR	RG 0007.0793.00	ROEDERSTEI	DC2 10,0KOHM 1%TK100	
.874 R875	RG 1,5 KOHM+-1%TK100 1206 RESISTOR CHIP	RG 0007.5714.00	ROEDERSTEI	DC2 1,5KOHM 1%TK100	
R876	RG 392 OHM+-1%TK100 1206 RESISTOR CHIP	RG 0007.5672.00	ROEDERSTEI	DC2 392OHM 1%TK100	
R880	RL 0,40W 470 OHM2% UNGEW. RESISTOR	RL 0092.6030.00	RESISTA	MK1 470OHM 2% UNGEW.	
R882	RG 18,2 OHM+-1%TK100 1206 RESISTOR CHIP	RG 0007.5466.00	ROEDERSTEI	DC2 18,2OHM 1%TK100	
R887	RG 221 OHM+-1%TK100 1206 RESISTOR CHIP	RG 0007.5614.00	ROEDERSTEI	DC2 221OHM 1%TK100	
R889	RG 47,5 OHM+-1%TK100 1206 RESISTOR CHIP NICHT BESTUECKT NOT FITTED	RG 0007.5566.00	ROEDERSTEI	DC2 47,5OHM 1%TK100	
R898	RG 100R +-1% TK200 0603 SMD-RESISTOR EIA0603	RG 0009.5334.00	DRALORIC	CR 0603 100R 1%TK200	
R899	RG 1,0MOHM+-1%TK100 1206 CHIP RESISTOR NICHT BESTUECKT NOT FITTED	RG 0815.7532.00	DRALORIC	CRC 1206	
U600	BM LRMS-2 MIXER 1GHZ HYBRID MIXER	1062.6273.00	MINI-CIRCU	LRMS-2	
U666	BM AK3000-1 DOPPLER FREQUENCY DOPPLER	1039.1256.00	MINI-CIRCU	AK-3000-1	
V11	AD BAS32 75V UDI DIODE	AD 0006.7288.00	PHILIPS	BAS32 (L)	
V12	AD BAS32 75V UDI DIODE	AD 0006.7288.00	PHILIPS	BAS32 (L)	
V13	AK BCX70H N 45V 200MA TRANSISTOR	AK 0007.3105.00	VALVO	BCX 70 H	
V14	AD BAS32 75V UDI DIODE NICHT BESTUECKT/NOT FITTED	AD 0006.7288.00	PHILIPS	BAS32 (L)	
V15	AD BAS32 75V UDI DIODE NICHT BESTUECKT/NOT FITTED	AD 0006.7288.00	PHILIPS	BAS32 (L)	
V25	AD BAS32 75V UDI DIODE	AD 0006.7288.00	PHILIPS	BAS32 (L)	
V26	AD BAS32 75V UDI DIODE	AD 0006.7288.00	PHILIPS	BAS32 (L)	
V35	AE BZV55/C5V1 0.5W ZDI ZENER DIODE	AE 0006.9839.00	PHILIPS_SE	BZV55B5V1 (GEG)	
V110	AE 1N827 6,2V REF DI REFERENCE DIODE	AE 0418.0029.00	COMPENSATE	1N827(A)	
V130	AD BAV99 70V DUO UDI DIODE	AD 0911.0092.00	VALVO	BAV99	
V134	AD BAV99 70V DUO UDI DIODE	AD 0911.0092.00	VALVO	BAV99	
V200	AK BCX70H N 45V 200MA TRANSISTOR	AK 0007.3105.00	VALVO	BCX 70 H	
V310	AE BAR61 3X(PI) 100V PIN PIN DIODE ARRAY (ATTENU.)	4001.5082.00	SIEMENS	BAR61(Q62702A120)	
V315	AE BAR61 3X(PI) 100V PIN PIN DIODE ARRAY (ATTENU.)	4001.5082.00	SIEMENS	BAR61(Q62702A120)	
V318	AD BAV99 70V DUO UDI DIODE	AD 0911.0092.00	VALVO	BAV99	
V319	AD BAV99 70V DUO UDI DIODE	AD 0911.0092.00	VALVO	BAV99	
V330	AD BAV99 70V DUO UDI DIODE	AD 0911.0092.00	VALVO	BAV99	
V333	AD BAV99 70V DUO UDI DIODE	AD 0911.0092.00	VALVO	BAV99	
V335 .337	AD BAV99 70V DUO UDI DIODE	AD 0911.0092.00	VALVO	BAV99	
V400	AE BAR61 3X(PI) 100V PIN PIN DIODE ARRAY (ATTENU.)	4001.5082.00	SIEMENS	BAR61(Q62702A120)	

MENP5

413 3PUA

ÄI

Datum
Date

Schaltteilliste für
Parts list for

Sachnummer
Stock No.

Blatt-Nr.
Page

 **ROHDE & SCHWARZ**

28 16.09.97

EE AUSGANGSTEIL 2.08GHZ
OUTPUT UNIT 2.08GHZ

1062.7005.01 SA

23+

095.0028-0693

Kennz. Comp. No.	Benennung Designation	Sachnummer Stock No.	Hersteller Manufacturer	Bezeichnung Designation	enthalten in contained in
V404	AD BAV99 70V DUO UDI DIODE	AD 0911.0092.00	VALVO	BAV99	
V405	AD BAV99 70V DUO UDI DIODE	AD 0911.0092.00	VALVO	BAV99	
V410	BM MSA1105 05-1.3G MMIC IC MICROWAVE MONOLITH AMP	1051.4051.00	AVANTEK	MSA-1105-TR1	
V411	AD BAS32 75V UDI DIODE	AD 0006.7288.00	PHILIPS	BAS32 (L)	
V431	AK BCX70H N 45V 200MA TRANSISTOR	AK 0007.3105.00	VALVO	BCX 70 H	
..438 V500	AE BAR64-04 CA DOPPEL PIN DUAL PIN DIODE	1039.1327.00	SIEMENS	BAR6404 (Q62702-A101	
V511	AE BAR64-04 CA DOPPEL PIN DUAL PIN DIODE	1039.1327.00	SIEMENS	BAR6404 (Q62702-A101	
V512	AE BAR64-04 CA DOPPEL PIN DUAL PIN DIODE	1039.1327.00	SIEMENS	BAR6404 (Q62702-A101	
V514	AE BAR64-04 CA DOPPEL PIN DUAL PIN DIODE	1039.1327.00	SIEMENS	BAR6404 (Q62702-A101	
..516 V520	AE BAR64-04 CA DOPPEL PIN DUAL PIN DIODE	1039.1327.00	SIEMENS	BAR6404 (Q62702-A101	
V523	AE BAR64-04 CA DOPPEL PIN DUAL PIN DIODE	1039.1327.00	SIEMENS	BAR6404 (Q62702-A101	
V530	AE BAR64-04 CA DOPPEL PIN DUAL PIN DIODE	1039.1327.00	SIEMENS	BAR6404 (Q62702-A101	
V532	AE BAR64-04 CA DOPPEL PIN DUAL PIN DIODE	1039.1327.00	SIEMENS	BAR6404 (Q62702-A101	
V535	AE BAR64-04 CA DOPPEL PIN DUAL PIN DIODE	1039.1327.00	SIEMENS	BAR6404 (Q62702-A101	
V536	AE BAR64-04 CA DOPPEL PIN DUAL PIN DIODE	1039.1327.00	SIEMENS	BAR6404 (Q62702-A101	
V539	AE BAR64-04 CA DOPPEL PIN DUAL PIN DIODE	1039.1327.00	SIEMENS	BAR6404 (Q62702-A101	
V540	AE BAR64-04 CA DOPPEL PIN DUAL PIN DIODE	1039.1327.00	SIEMENS	BAR6404 (Q62702-A101	
V543	AE BAR64-04 CA DOPPEL PIN DUAL PIN DIODE	1039.1327.00	SIEMENS	BAR6404 (Q62702-A101	
V544	AE BAR64-04 CA DOPPEL PIN DUAL PIN DIODE	1039.1327.00	SIEMENS	BAR6404 (Q62702-A101	
V548	AE BAR64-04 CA DOPPEL PIN DUAL PIN DIODE	1039.1327.00	SIEMENS	BAR6404 (Q62702-A101	
V600	AE BZX55/B6V2 0,5W ZDI ZENER DIODE	AE 0012.2161.00	PHILIPS	BZX79B6V2	
V602	AK BFQ34T N 18V 150MA TRANSISTOR	0801.8283.00	PHILIPS	BFQ34T	
V604	AE HSMS2825 1+1 SCHOTTKY SCHOTTKY DIODE PAIR	1010.6214.00	HEWLETT_PA	HSMS2825 L31	
V606	AE HSMS2825 1+1 SCHOTTKY SCHOTTKY DIODE PAIR	1010.6214.00	HEWLETT_PA	HSMS2825 L31	
V608	AD BAS32 75V UDI DIODE	AD 0006.7288.00	PHILIPS	BAS32 (L)	
V610	AE BZV55/C5V1 0.5W ZDI ZENER DIODE	AE 0006.9839.00	PHILIPS_SE	BZV55B5V1 (GEG)	
V612	AK BFQ34T N 18V 150MA TRANSISTOR	0801.8283.00	PHILIPS	BFQ34T	
V635	AD BAS32 75V UDI DIODE	AD 0006.7288.00	PHILIPS	BAS32 (L)	
V636	AE 1N827 6,2V REF DI REFERENCE DIODE	AE 0418.0029.00	COMPENSATE	1N827(A)	
V656	AD BAS32 75V UDI DIODE	AD 0006.7288.00	PHILIPS	BAS32 (L)	
V670	BM MSA0486 DC-3.2G MMIC BROADBAND AMPLIFIER NICHT BESTUECKT NOT FITTED	0846.4293.00	AVANTEK	MSA-0486	
V671	BM MSA1105 05-1.3G MMIC IC MICROWAVE MONOLITH AMP	1051.4051.00	AVANTEK	MSA-1105-TR1	
V680	AD BAV99 70V DUO UDI DIODE	AD 0911.0092.00	VALVO	BAV99	
..683 V700	AE HSMS2825 1+1 SCHOTTKY SCHOTTKY DIODE PAIR	1010.6214.00	HEWLETT_PA	HSMS2825 L31	
V705	AE BAR64-04 CA DOPPEL PIN DUAL PIN DIODE	1039.1327.00	SIEMENS	BAR6404 (Q62702-A101	
V707	AE BAR64-04 CA DOPPEL PIN DUAL PIN DIODE	1039.1327.00	SIEMENS	BAR6404 (Q62702-A101	
V715	AD BAS32 75V UDI DIODE	AD 0006.7288.00	PHILIPS	BAS32 (L)	
V716	AD BAS32 75V UDI DIODE	AD 0006.7288.00	PHILIPS	BAS32 (L)	

Für diese Untereinige behalten wir uns alle Rechte vor.

095.0028-0693

MENP5	413 3PUA	ÄI	Datum Date	Schaltteilliste für Parts list for	Sachnummer Stock No.	Blatt-Nr. Page
	28	16.09.97	EE AUSGANGSTEIL 2.08GHZ OUTPUT UNIT 2.08GHZ	1062.7005.01 SA	24+	

Für diese Unterlage behalten
wir uns alle Rechte vor.

Kennz. Comp. No.	Benennung Designation	Sachnummer Stock No.	Hersteller Manufacturer	Bezeichnung Designation	enthalten in contained in
V717	AE BZV55/C6V2 0,5W ZDI ZENER DIODE	AE 0006.9851.00	PHILIPS	BZV55B6V2	
V718	AE BZV55/C6V2 0,5W ZDI ZENER DIODE	AE 0006.9851.00	PHILIPS	BZV55B6V2	
V720	AE BAR64-04 CA DOPPEL PIN DUAL PIN DIODE	1039.1327.00	SIEMENS	BAR6404 (Q62702-A101)	
V725	AE BAR64-04 CA DOPPEL PIN DUAL PIN DIODE	1039.1327.00	SIEMENS	BAR6404 (Q62702-A101)	
V730	AE BAR64-04 CA DOPPEL PIN DUAL PIN DIODE	1039.1327.00	SIEMENS	BAR6404 (Q62702-A101)	
V735	AE BAR64-04 CA DOPPEL PIN DUAL PIN DIODE	1039.1327.00	SIEMENS	BAR6404 (Q62702-A101)	
V745	AE BZV55/C6V2 0,5W ZDI ZENER DIODE	AE 0006.9851.00	PHILIPS	BZV55B6V2	
V746	AE BZV55/C6V2 0,5W ZDI ZENER DIODE	AE 0006.9851.00	PHILIPS	BZV55B6V2	
V747	AD BAS32 75V UDI DIODE	AD 0006.7288.00	PHILIPS	BAS32 (L)	
V748	AD BAS32 75V UDI DIODE	AD 0006.7288.00	PHILIPS	BAS32 (L)	
V750	AD BAS32 75V UDI DIODE	AD 0006.7288.00	PHILIPS	BAS32 (L)	
..753					
V765	AD BAV99 70V DUO UDI DIODE	AD 0911.0092.00	VALVO	BAV99	
V766	AD BAV99 70V DUO UDI DIODE	AD 0911.0092.00	VALVO	BAV99	
V768	AE BAR61 3X(PI) 100V PIN PIN DIODE ARRAY (ATTENU.)	4001.5082.00	SIEMENS	BAR61(Q62702A120)	
V769	BM MSA0486 DC-3.2G MMIC BROADBAND AMPLIFIER	0846.4293.00	AVANTEK	MSA-0486	
V770	AE BAR64-04 CA DOPPEL PIN DUAL PIN DIODE	1039.1327.00	SIEMENS	BAR6404 (Q62702-A101)	
..775					
V780	BM MSA0486 DC-3.2G MMIC BROADBAND AMPLIFIER NICHT BESTUECKT NOT FITTED	0846.4293.00	AVANTEK	MSA-0486	
V782	AE BAR64-04 CA DOPPEL PIN DUAL PIN DIODE	1039.1327.00	SIEMENS	BAR6404 (Q62702-A101)	
..787					
V801	BM MSA0486 DC-3.2G MMIC BROADBAND AMPLIFIER	0846.4293.00	AVANTEK	MSA-0486	
V802	AE BZV55/C6V2 0,5W ZDI ZENER DIODE	AE 0006.9851.00	PHILIPS	BZV55B6V2	
V803	AE BZV55/C6V2 0,5W ZDI ZENER DIODE	AE 0006.9851.00	PHILIPS	BZV55B6V2	
V804	AD BAS32 75V UDI DIODE	AD 0006.7288.00	PHILIPS	BAS32 (L)	
V805	AD BAS32 75V UDI DIODE	AD 0006.7288.00	PHILIPS	BAS32 (L)	
V814	AD BAS32 75V UDI DIODE	AD 0006.7288.00	PHILIPS	BAS32 (L)	
V815	AD BAS32 75V UDI DIODE	AD 0006.7288.00	PHILIPS	BAS32 (L)	
V816	AK BCX71J P 45V 200MA TRANSISTOR	AK 0007.2096.00	VALVO	BCX71J GEGURTET	
V817	AK AT-64020 TRANSISTOR TRANSISTOR	1039.1404.00	AVANTEK	AT-64020	
V827	AD BAS32 75V UDI DIODE	AD 0006.7288.00	PHILIPS	BAS32 (L)	
V828	AK BCP68-16 N 20V TRANS TRANSISTOR BCP68	0008.2019.00	PHILIPS	BCP68-25	
V829	AK BCX71J P 45V 200MA TRANSISTOR	AK 0007.2096.00	VALVO	BCX71J GEGURTET	
V830	AD BAS32 75V UDI DIODE	AD 0006.7288.00	PHILIPS	BAS32 (L)	
V831	AK BCX71J P 45V 200MA TRANSISTOR	AK 0007.2096.00	VALVO	BCX71J GEGURTET	
V832	AK AT-64020 TRANSISTOR TRANSISTOR	1039.1404.00	AVANTEK	AT-64020	
V833	AK BCX71J P 45V 200MA TRANSISTOR	AK 0007.2096.00	VALVO	BCX71J GEGURTET	
V834	AK BCP68-16 N 20V TRANS TRANSISTOR BCP68	0008.2019.00	PHILIPS	BCP68-25	
V844	AE BAT62 1+1 40V SCHOTTKY DIODE PAIR	1051.4045.00	SIEMENS	BAT62 (62)	
V850	AE HSMS2825 1+1 SCHOTTKY SCHOTTKY DIODE PAIR	1010.6214.00	HEWLETT_PA	HSMS2825 L31	
V853	AD BAS32 75V UDI DIODE	AD 0006.7288.00	PHILIPS	BAS32 (L)	

MENP5

413 3PUA

ÄI

Datum
Date

Schaltteilliste für
Parts list for

Sachnummer
Stock No.

Blatt-Nr.
Page



ROHDE & SCHWARZ

28 16.09.97

EE AUSGANGSTEIL 2.08GHZ
OUTPUT UNIT 2.08GHZ

1062.7005.01 SA

25+

Für diese Unterlage behalten wir uns alle Rechte vor.

Kennz. Comp. No.	Benennung Designation	Sachnummer Stock No.	Hersteller Manufacturer	Bezeichnung Designation	enthalten in contained in
V857	AD BAS32 75V UDI DIODE	AD 0006.7288.00	PHILIPS	BAS32 (L)	
V870	AD BAS32 75V UDI DIODE	AD 0006.7288.00	PHILIPS	BAS32 (L)	
V871	AE 1N827 6,2V REF DI REFERENCE DIODE	AE 0418.0029.00	COMPENSATE	1N827(A)	
V874	BM MSA0486 DC-3.2G MMIC BROADBAND AMPLIFIER	0846.4293.00	AVANTEK	MSA-0486	
V875	AE HSMS2825 1+1 SCHOTTKY SCHOTTKY DIODE PAIR	1010.6214.00	HEWLETT_PA	HSMS2825 L31	
V876	AE BAR61 3X(PI) 100V PIN PIN DIODE ARRAY (ATTENU.)	4001.5082.00	SIEMENS	BAR61(Q62702A120)	
V877	AE BAR61 3X(PI) 100V PIN PIN DIODE ARRAY (ATTENU.)	4001.5082.00	SIEMENS	BAR61(Q62702A120)	
W1	DW KABEL W1	1062.7086.00			
X2	FP STECKERLEISTE 32POL. CONNECTOR 32P.	FP 0008.5718.00	SIEMENS	V42254-B1200-B611	
X205	FP STIFTLISTE 4P.R2,54 PIN CONNECTOR	FP 0009.6147.00			
X224 ..226	FJ EINBAUWINKELST. SMC ANGLE CONNECTOR	FJ 0249.9684.00	ROSENBERGE	39S-205-400-D3	
Z1	LD SMD-T-FILTER 3,3NF SMD-FILTER	1039.1362.00	MURATA	NFM61R20T332T1	
Z2	LD SMD PI-FILTER 10GHZ SURFACE-MOUNT-FILTER	LD 0008.5901.00	OXLEY	SLT/P/22000/SM3	
Z3	LD SMD-T-FILTER 3,3NF SMD-FILTER	1039.1362.00	MURATA	NFM61R20T332T1	
Z4	LD SMD-T-FILTER 3,3NF SMD-FILTER	1039.1362.00	MURATA	NFM61R20T332T1	
Z5 ..9	LD SMD-T-FILTER 100PF SMD-FILTER	1039.1356.00	MURATA	NFM61ROOT101T1	
Z10	LD SMD-T-FILTER 3,3NF SMD-FILTER	1039.1362.00	MURATA	NFM61R20T332T1	
Z11	LD SMD-T-FILTER 100PF SMD-FILTER	1039.1356.00	MURATA	NFM61ROOT101T1	
Z20	LD SMD PI-FILTER 10GHZ SURFACE-MOUNT-FILTER	LD 0008.5901.00	OXLEY	SLT/P/22000/SM3	
Z700	XX ENTHALTEN IN INCLUDED IN				
Z710	IN LEITERPLATTE INCLUDED IN				
Z720	XX ENTHALTEN IN INCLUDED IN				
	IN LEITERPLATTE				

MENP5	413 3PUA	Äi	Datum Date	Schalttailliste für Parts list for	Sachnummer Stock No.	Blatt-Nr. Page
	28	16.09.97	EE AUSGANGSTEIL 2.08GHZ OUTPUT UNIT 2.08GHZ	1062.7005.01 SA	26-	

095.0026-0693

XY-Liste

XY List

Erklärung der Spaltenbezeichnungen:

- Part:** Bauelement-Kennzeichen.
- Side:** Leiterplatten-Seite, auf der sich das Bauelement befindet.
- X/Y:** Koordinaten (Millimeter) des Bauelementes auf der Leiterplatte bezogen auf den Nullpunkt.
- SQR, PG:** Planquadrat und Seite des Schaltbildes für das jeweilige Bauelement.

Explanation of column designations:

- Part:** Identification of instrument part.
- Side:** Side of the PC board on which instrument part is positioned.
- X/Y:** Coordinates (millimeter) of the component on the PC board in reference to zero point.
- SQR, PG:** Square and page of the diagram for the respective instrument part.

Nicht-Service-Relevante Bauteile / Non-Service-Relevant Components

Part	Side	X	Y	Sqr	Pg	Part	Side	X	Y	Sqr	Pg	Part	Side	X	Y	Sqr	Pg
303	B	18	53	9D	4	C22	B	114	32	3E	2	C327	B	17	48	6D	4
309	B	30	71	10D	4	C132	B	225	35	9B	10	C328	B	19	41	7D	4
310	B	22	71	11D	4	C133	B	232	38	8B	10	C329	A	39	41	7C	4
413	B	50	69	5D	5	C149	A	210	43	3A	10	C330	A	43	38	7C	4
414	B	40	70	5D	5	C150	A	177	44	1A	10	C340	B	45	50	8C	4
506	B	81	83	3E	6	C151	A	168	53	2A	10	C356	B	31	46	8D	4
507	B	92	102	3D	6	C152	A	87	57	3A	10	C357	B	31	53	9D	4
509	B	92	83	4D	6	C153	B	128	54	6A	10	C359	A	41	60	10E	4
514	B	96	95	5D	6	C154	A	135	53	6A	10	C360	B	31	67	10D	4
515	B	111	95	5D	6	C156	A	200	43	4A	10	C361	B	23	83	12D	4
516	B	112	88	5D	6	C157	A	158	53	5A	10	C362	A	48	86	11E	4
518	B	123	89	6D	6	C158	A	257	173	6A	10	C400	A	48	84	2C	5
519	B	125	87	6D	6	C159	A	241	177	6A	10	C401	B	42	81	3D	5
520	B	135	95	7D	6	C160	A	135	42	6E	10	C402	B	30	78	4D	5
522	B	137	75	7E	6	C161	A	99	44	9E	10	C404	A	34	88	3C	5
528	B	148	82	8D	6	C162	A	76	22	10E	10	C405	A	35	91	4C	5
529	B	148	91	8D	6	C170	A	188	43	4A	10	C410	A	42	76	5E	5
542	B	46	98	2B	6	C207	B	90	18	10D	3	C412	B	37	72	5D	5
543	B	20	111	2B	6	C208	B	82	46	8C	3	C417	A	70	70	7E	5
544	B	23	116	3B	6	C209	A	95	44	6C	3	C440	A	126	123	9B	5
545	B	37	111	4B	6	C219	B	82	43	8C	3	C441	A	133	138	9B	5
548	B	76	132	6B	6	C220	A	54	39	9E	3	C442	A	114	109	10B	5
550	B	145	137	8B	6	C221	B	64	21	9D	3	C445	B	63	86	1C	6
600	B	178	70	2E	7	C240	B	57	12	10E	3	C500	B	64	77	2E	6
602	B	63	178	8D	11	C242	B	66	16	11F	3	C501	A	83	83	2F	6
607	B	215	83	4D	7	C244	A	78	40	4A	3	C502	B	70	88	2D	6
608	B	208	86	5D	7	C245	A	72	49	4A	3	C504	B	78	86	3D	6
612	B	218	62	3D	7	C250	A	58	62	2A	3	C505	B	79	94	3E	6
650	B	122	151	2D	11	C251	A	64	62	2A	3	C506	B	91	97	3E	6
651	B	91	151	3D	11	C252	A	55	57	2A	3	C507	B	91	88	4E	6
660	B	218	62	3D	7	C253	A	59	51	2A	3	C509	A	97	86	4F	6
661	B	218	62	4D	7	C254	A	63	51	3A	3	C510	B	97	90	5E	6
705	B	150	122	2C	8	C255	A	55	47	3A	3	C511	B	112	99	5E	6
706	B	154	175	5D	12	C256	A	164	39	5A	3	C512	B	110	85	5E	6
707	B	161	145	5D	12	C257	A	57	18	6A	3	C513	B	104	74	5E	6
708	B	232	189	9D	12	C258	A	53	15	5A	3	C514	A	117	83	6F	6
740	B	192	129	8D	8	C259	A	163	34	5A	3	C515	B	121	85	6E	6
766	B	171	147	5D	12	C260	A	111	44	6A	3	C516	B	122	99	6E	6
777	B	226	185	9D	12	C261	A	59	30	3A	3	C517	B	133	90	7E	6
778	B	231	187	9E	12	C262	A	64	31	3A	3	C518	A	135	87	7F	6
840	B	277	53	10D	9	C263	A	55	25	4A	3	C519	B	146	77	8E	6
847	B	280	83	8D	9	C264	A	115	44	6A	3	C520	B	146	86	8E	6
851	B	288	15	11D	9	C275	B	163	41	1D	3	C521	B	146	94	8E	6
853	B	279	79	8D	9	C280	B	135	37	3C	3	C522	B	140	77	8E	6
857	B	279	57	10D	9	C300	B	39	20	3D	4	C523	B	140	86	8E	6
C12	B	208	33	8C	2	C302	B	24	27	4D	4	C524	B	141	94	8E	6
C13	B	113	29	3F	2	C303	B	34	23	4D	4	C525	B	147	102	9E	6
C14	A	227	44	5A	2	C313	B	45	29	5C	4	C526	A	140	113	9F	6
C15	A	235	45	5A	2	C315	B	18	24	5D	4	C527	B	150	111	11E	6
C16	A	227	21	6A	2	C316	B	22	34	6D	4	C530	A	59	93	2C	6
C17	A	239	14	6A	2	C318	A	12	37	5C	4	C531	B	72	96	2C	6
C20	B	107	16	2D	2	C319	A	15	41	6C	4	C532	B	52	97	2B	6
C21	B	126	32	3E	2	C325	B	30	38	6D	4	C533	B	19	104	2B	6

ROHDE & SCHWARZ	-I	Datum Date	XY-Liste für XY-list for	Sach-Nummer Stock-Nr	Blatt Page
	03	17.06.96	EE AUSGANGSTEIL_2.08GHZ OUTPUT_UNIT_2.08GHZ	1062.7005.01 XY	1+

Part	Side	X	Y	Sqr	Pg	Part	Side	X	Y	Sqr	Pg	Part	Side	X	Y	Sqr	Pg
C534	B	43	104	3B	6	C634	B	254	87	8D	7	C726	A	241	135	10E	8
C536	A	78	109	3C	6	C635	B	236	95	10D	7	C727	A	169	104	5E	8
C537	B	54	115	4B	6	C636	B	238	98	10D	7	C728	A	220	120	10D	8
C538	B	38	118	4B	6	C637	B	245	83	9E	7	C729	A	220	135	10D	8
C539	B	56	123	5B	6	C638	A	223	85	3A	7	C732	B	184	99	6D	8
C540	A	86	120	5C	6	C639	A	219	77	3B	7	C734	B	177	100	7C	8
C545	B	65	132	6B	6	C640	B	220	92	10E	7	C735	A	180	102	6C	8
C546	B	37	131	6B	6	C641	B	223	95	10D	7	C736	A	177	93	7C	8
C547	B	59	137	7B	6	C642	B	207	95	10D	7	C738	B	191	103	7D	8
C553	A	89	131	7C	6	C643	B	204	110	11D	7	C740	B	192	113	8D	8
C560	B	113	139	8B	6	C644	B	213	113	11E	7	C741	B	154	186	3A	12
C562	B	128	133	9B	6	C645	B	219	113	11D	7	C742	A	204	121	9E	8
C564	B	116	130	9B	6	C646	B	227	109	11D	7	C743	B	210	128	9D	8
C568	B	92	112	10B	6	C647	B	207	114	11E	7	C744	A	272	187	11E	12
C569	A	90	114	10C	6	C650	A	183	69	7A	7	C745	B	148	188	3A	12
C570	B	102	110	10B	6	C651	A	187	64	7A	7	C747	A	225	131	11D	8
C571	B	102	119	10C	6	C652	A	215	67	6A	7	C748	A	228	127	11D	8
C573	B	111	110	11B	6	C653	A	218	67	6A	7	C750	A	211	133	11E	8
C575	B	119	110	11B	6	C654	B	242	97	9D	7	C751	A	198	124	11E	8
C580	B	126	106	11C	6	C656	A	209	67	2B	7	C753	A	203	135	11D	8
C582	B	135	106	11D	6	C660	A	157	91	4F	7	C754	A	154	147	2B	12
C583	B	135	119	12D	6	C661	A	171	86	4F	7	C755	A	157	153	2B	12
C584	B	144	113	12D	6	C662	A	157	80	4E	7	C756	A	149	147	2B	12
C585	A	103	71	2A	6	C663	A	178	75	4E	7	C757	A	146	154	2B	12
C599	B	140	106	9D	6	C664	B	210	95	10D	7	C762	A	183	121	7E	8
C600	B	170	86	1D	7	C668	A	153	72	5F	7	C765	B	90	175	2D	12
C601	B	175	79	1D	7	C669	A	121	164	3E	11	C766	B	103	185	2E	12
C602	B	180	69	2E	7	C670	A	269	109	7F	7	C767	B	100	177	2D	12
C603	B	167	73	2D	7	C671	A	264	97	7F	7	C768	B	101	171	2D	12
C604	B	194	74	3D	7	C672	B	129	151	2D	11	C769	B	109	175	3D	12
C605	B	217	67	4E	7	C673	B	98	151	3D	11	C770	A	104	180	2D	12
C606	B	220	76	4E	7	C674	A	86	162	4E	11	C771	A	114	171	2C	12
C607	B	218	86	5E	7	C675	B	56	151	4D	11	C772	B	119	185	3D	12
C608	B	229	83	5E	7	C676	B	29	172	6D	11	C773	B	265	183	11E	12
C609	A	181	86	2E	7	C677	A	49	177	7E	11	C774	B	142	175	5D	12
C610	A	202	77	2C	7	C678	B	53	181	7D	11	C775	A	131	183	4E	12
C611	A	168	64	4C	7	C679	B	60	181	8D	11	C776	A	187	146	6C	12
C612	A	128	156	2B	11	C680	A	55	190	8E	11	C777	A	184	154	6C	12
C613	A	133	162	2B	11	C681	A	46	190	8E	11	C778	A	172	166	6C	12
C614	A	105	149	2A	11	C682	B	78	185	9C	11	C779	A	234	166	6B	12
C615	A	105	157	2A	11	C700	B	151	119	2D	8	C780	A	207	182	6B	12
C616	B	91	147	3D	11	C701	A	148	129	2D	8	C781	A	209	184	6A	12
C617	B	264	27	5C	7	C702	A	148	122	2E	8	C783	B	194	149	6E	12
C618	B	256	30	5C	7	C705	B	166	137	3C	8	C784	B	194	154	7D	12
C619	B	264	37	6C	7	C707	B	170	124	4C	8	C785	B	166	170	7C	12
C620	B	255	40	6C	7	C708	B	166	115	4C	8	C786	B	205	189	8C	12
C621	B	58	147	4D	11	C709	A	166	120	4C	8	C787	B	203	179	8D	12
C623	B	116	151	2D	11	C710	A	168	114	4C	8	C788	B	232	166	8E	12
C625	B	250	69	7D	7	C714	B	169	109	4C	8	C789	B	222	146	7E	12
C627	B	260	74	7D	7	C715	B	170	98	5C	8	C790	B	197	160	7D	12
C628	B	269	76	8D	7	C720	A	180	137	4D	8	C791	B	174	174	7D	12
C629	B	265	82	8D	7	C721	B	177	129	4D	8	C792	B	184	186	7D	12
C631	B	183	76	2D	7	C723	A	184	130	4D	8	C793	B	210	172	7D	12
C632	B	189	79	3D	7	C724	B	184	128	4E	8	C794	B	237	157	7E	12
C633	B	260	88	9D	7	C725	A	238	121	10E	8	C795	B	235	185	9D	12

ROHDE & SCHWARZ	-I	Datum Date	XY-Liste für XY-list for	Sach-Nummer Stock-Nr	Blatt Page
	03	17.06.96	EE AUSGANGSTEIL_2.08GHZ OUTPUT_UNIT_2.08GHZ	1062.7005.01 XY	2+

Part	Side	X	Y	Sqr	Pg	Part	Side	X	Y	Sqr	Pg	Part	Side	X	Y	Sqr	Pg
C796	B	243	187	9D	12	C890	A	96	177	11C	11	D210-C				7D	3
C797	B	246	187	10D	12	C892	A	105	187	11C	11	D210-D				7E	3
C798	B	252	185	10D	12	C893	B	86	171	11C	11	D210-E				2A	3
C799	B	265	164	11D	12	C894	A	76	185	10D	11	D220-A	B	57	23	10C	3
C800	B	267	140	2D	9	D10-A	B	230	18	7E	2	D220-B				7D	3
C801	A	272	149	3E	9	D10-B				6A	2	D220-C				7D	3
C802	A	265	148	3E	9	D100-A	B	208	39	8C	2	D220-D				10C	3
C803	A	269	166	2E	9	D100-B				9C	2	D220-E				3A	3
C804	A	262	164	3E	9	D100-C				10C	2	D430-A	A	120	111	9D	5
C805	B	275	159	3D	9	D100-D				6D	10	D430-B				8B	5
C806	A	279	136	5E	9	D100-E				3A	10	D431-A	A	109	111	10B	5
C808	B	284	137	5D	9	D102-A	B	175	39	2E	10	D431-B				10E	5
C810	B	279	92	8D	9	D102-B				1A	10	D431-C				10E	5
C812	B	280	86	8D	9	D105-A	B	187	39	3C	10	D431-D				10D	5
C816	B	274	116	6C	9	D105-B				3C	10	D431-E				10D	5
C817	B	281	117	6D	9	D105-C				8C	10	D431-F				10D	5
C818	B	284	107	7D	9	D105-D				7A	10	D431-G				10B	5
C819	B	277	107	7E	9	D105-E				3A	10	D432-A	A	130	128	10C	5
C820	A	293	175	7E	9	D110-A	B	161	53	4E	10	D432-B				10C	5
C821	B	286	183	8E	9	D110-B				2A	10	D432-C				10C	5
C828	B	284	85	8D	9	D111-A	A	148	44	6C	10	D432-D				11B	5
C830	B	276	51	10D	9	D111-B				6C	10	D432-E				11B	5
C831	B	283	72	9D	9	D111-C				6C	10	D432-F				10B	5
C832	B	280	69	9E	9	D111-D				6B	10	D432-G				9B	5
C833	A	260	116	9E	9	D111-E				4A	10	D759	B	217	128	10D	8
C834	B	252	116	10E	9	D112-A	A	148	55	6B	10	D760	B	235	130	11D	8
C836	B	292	44	10D	9	D112-B				6B	10	D800	B	270	156	2D	9
C839	B	284	57	10E	9	D112-C				6B	10	L20	B	124	15	2D	2
C840	A	154	102	2B	9	D112-D				7A	10	L21	A	103	16	2D	2
C841	A	157	108	3B	9	D112-E				5A	10	L22	B	98	29	3D	2
C842	A	153	121	2A	9	D115-A	B	197	39	4C	10	L300	B	27	23	4D	4
C843	A	154	128	3A	9	D115-B				7C	10	L301	B	45	23	3D	4
C844	B	287	21	11D	9	D115-C				3E	10	L305	B	39	32	5D	4
C846	B	283	30	7C	9	D115-D				7A	10	L325	B	17	39	6D	4
C847	B	282	39	8C	9	D115-E				4A	10	L340	B	39	44	8D	4
C848	B	284	22	8C	9	D120-A	B	86	53	7E	10	L350	B	23	67	10D	4
C849	B	282	50	10D	9	D120-B				2A	10	L351	B	23	67	10D	4
C850	A	286	91	6A	9	D140-A	B	142	39	6E	10	L353	B	41	53	10E	4
C851	A	296	81	7A	9	D140-B				2B	3	L355	B	34	50	9D	4
C852	A	278	82	6B	9	D141-A	B	146	42	4E	3	L360	B	19	89	11D	4
C853	A	291	75	6C	9	D141-B				1C	3	L361	B	55	86	11E	4
C854	A	292	34	8A	9	D141-C				1B	3	L380	B	20	89	11D	4
C855	A	279	38	8A	9	D141-D				4D	3	L400	B	30	83	2D	5
C870	A	296	86	11B	9	D141-E				4A	3	L410	B	46	76	4D	5
C871	A	300	74	11C	9	D145-A	B	95	37	8E	10	L416	B	72	73	6D	5
C880	A	253	109	6F	9	D145-B				5B	3	L417	B	62	70	6E	5
C881	B	286	92	8E	9	D150-A	B	74	15	10E	10	L431	A	97	89	11E	5
C882	B	83	181	10C	11	D150-B				9E	3	L432	A	118	90	11E	5
C883	B	77	181	9C	11	D200-A	B	57	55	4F	3	L500	B	81	77	2E	6
C884	B	72	172	10C	11	D200-B				4E	3	L505	B	94	89	4F	6
C885	A	152	131	2B	9	D200-C				4E	3	L510	B	114	86	6F	6
C886	A	155	138	3B	9	D200-D				4E	3	L517	B	137	91	7F	6
C887	A	72	182	9C	11	D200-E				1A	3	L520	B	147	119	9E	6
C888	A	56	172	10C	11	D210-A	B	57	42	7E	3	L530	B	56	93	2C	6
C889	A	85	181	10C	11	D210-B				7E	3	L532	B	55	98	2B	6

ROHDE & SCHWARZ	-I	Datum Date	XY-Liste f#r XY-list for	Sach-Nummer Stock-Nr	Blatt Page
		03 17.06.96	EE AUSGANGSTEIL_2.08GHZ OUTPUT_UNIT_2.08GHZ	1062.7005.01 XY	3+

Part	Side	X	Y	Sqr	Pg	Part	Side	X	Y	Sqr	Pg	Part	Side	X	Y	Sqr	Pg
L533	B	20	101	2B	6	L662	A	157	83	3F	7	N130-A	B	142	52	10D	10
L534	B	40	103	3B	6	L663	A	175	75	4F	7	N130-B				10C	10
L536	B	81	109	3C	6	L668	A	157	75	5F	7	N130-C				6A	10
L537	B	57	115	4B	6	L669	B	49	171	7D	11	N131-A	A	244	168	10C	10
L538	B	45	116	4B	6	L670	A	267	112	7F	7	N131-B				10C	10
L539	B	52	122	5B	6	L671	A	264	93	7F	7	N131-C				6A	10
L540	B	35	118	4B	6	L672	B	102	161	3D	11	N223-A	B	88	38	6C	3
L541	B	61	119	5B	6	L673	B	134	164	3E	11	N223-B				7B	3
L542	B	64	123	5B	6	L674	B	58	163	4D	11	N223-C				7A	3
L543	B	89	119	5C	6	L675	B	106	164	4E	11	N228-A	B	60	12	10E	3
L544	B	44	134	7B	6	L676	B	62	175	7E	11	N228-B				11E	3
L545	B	72	129	6B	6	L677	B	86	175	11D	11	N228-C				5A	3
L546	B	45	129	6B	6	L678	B	72	175	9C	11	N235-A	B	76	46	8C	3
L547	B	55	134	7B	6	L679	B	80	182	10D	11	N235-B				4A	3
L548	B	52	129	6B	6	L705	B	166	134	3C	8	N275-A	B	167	34	2D	3
L549	B	82	130	7B	6	L706	B	178	135	3C	8	N275-B				2D	3
L550	B	26	129	6B	6	L709	B	166	121	4C	8	N275-C				5A	3
L551	B	33	137	7B	6	L714	B	169	101	5C	8	N276-A	B	111	41	3C	3
L553	B	89	135	7C	6	L720	B	181	126	4D	8	N276-B				4B	3
L559	B	97	135	8B	6	L727	A	170	107	5E	8	N276-C				6A	3
L560	B	105	138	8B	6	L730	B	183	112	5D	8	N300	B	17	55	9D	4
L561	B	118	136	9B	6	L732	B	181	97	7C	8	N360	B	17	72	11D	4
L562	B	124	136	9B	6	L738	B	192	100	7D	8	N600-A	A	210	70	2C	7
L563	B	141	133	9B	6	L739	B	192	110	8D	8	N600-B				2B	7
L564	B	121	130	9B	6	L740	B	205	138	9D	8	N600-C				3B	7
L565	B	102	128	9B	6	L742	B	211	121	9E	8	N600-D				3A	7
L566	B	141	128	9B	6	L748	B	205	128	9D	8	N600-E				6A	7
L568	B	87	114	10C	6	L754	A	234	127	11D	8	N610-A	A	193	70	3C	7
L570	B	99	110	10B	6	L755	A	157	150	2B	12	N610-B				5A	7
L571	B	108	117	11B	6	L756	A	145	150	2B	12	N740	B	194	134	8D	8
L572	B	117	119	11B	6	L765	B	98	185	2E	12	N776-A	A	146	168	6C	12
L580	B	124	119	11C	6	L766	B	107	175	3D	12	N776-B				6B	12
L583	B	133	117	11C	6	L767	B	137	185	4E	12	N776-C				4A	12
L584	B	141	110	11D	6	L768	B	141	188	4E	12	N777-A	A	146	156	6C	12
L585	A	99	74	2A	6	L770	B	259	189	11E	12	N777-B				6B	12
L600	B	174	86	2F	7	L771	B	276	169	11E	12	N777-C				3A	12
L601	B	180	82	2E	7	L800	B	294	142	5E	9	N778-A	A	146	179	6C	12
L602	B	171	67	2D	7	L801	B	276	130	5F	9	N778-B				6B	12
L604	A	171	64	4C	7	L816	B	284	110	6D	9	N778-C				3A	12
L608	B	218	73	4E	7	L817	B	293	187	8E	9	N840-A	A	286	81	6B	9
L610	B	220	82	5E	7	L818	B	295	73	8E	9	N840-B				10B	9
L612	A	129	162	2B	11	L819	B	291	86	8E	9	N840-C				11B	9
L613	A	106	155	2A	11	L829	B	299	34	10E	9	N840-D				11C	9
L630	B	257	69	7D	7	L830	B	297	47	10E	9	N840-E				6A	9
L632	B	266	69	8D	7	L831	B	242	124	10E	9	N845-A	A	283	33	7B	9
L633	B	243	70	7D	7	L840	A	158	105	3B	9	N845-B				7A	9
L642	B	268	99	9E	7	L841	A	157	124	3A	9	P300	B	86	36	6C	3
L643	B	239	77	9E	7	L845	B	277	17	9B	9	P305	B	67	39	10C	3
L645	B	213	98	10D	7	L880	B	257	109	6F	9	P352	B	59	21	11D	3
L647	B	204	107	11D	7	L885	A	156	135	3B	9	P353	B	62	21	12E	3
L649	B	218	107	11D	7	N20-A	B	225	41	9B	10	P375	B	155	34	2D	3
L650	B	224	110	11D	7	N20-B				10B	10	P380	B	119	41	4C	3
L651	B	233	108	12D	7	N20-C				7D	2	P385	B	109	50	5C	3
L660	A	157	88	3F	7	N20-D				7C	2	P600	B	186	62	3C	7
L661	A	171	83	4F	7	N20-E				5A	2	P601	B	187	85	3C	7

ROHDE & SCHWARZ	-I	Datum Date	XY-Liste für XY-list for	Sach-Nummer Stock-Nr	Blatt Page
	03	17.06.96	EE AUSGANGSTEIL_2.08GHZ OUTPUT_UNIT_2.08GHZ	1062.7005.01 XY	4+

Part	Side	X	Y	Sqr	Pg	Part	Side	X	Y	Sqr	Pg	Part	Side	X	Y	Sqr	Pg
P620	B	222	72	4B	7	R123	A	197	45	7A	10	R308	B	22	17	3D	4
P621	B	223	70	4A	7	R124	A	194	45	7A	10	R310	B	42	23	3D	4
P628	B	177	64	4C	7	R130	B	128	57	10D	10	R312	B	37	20	3D	4
P848	B	277	32	7C	9	R131	B	225	37	9B	10	R313	A	18	28	5C	4
P866	B	297	23	8B	9	R132	B	232	36	9B	10	R314	B	41	32	5D	4
R1	A	119	17	2F	2	R133	B	236	47	8B	10	R315	B	46	36	4C	4
R9	A	226	55	7D	2	R134	B	250	173	10C	10	R316	B	45	27	5C	4
R10	B	219	50	7C	2	R149	B	200	36	7C	10	R317	B	12	44	5C	4
R11	A	229	51	7D	2	R160	B	125	44	5E	10	R318	B	15	44	6C	4
R12	B	222	46	7C	2	R161	A	139	47	5E	10	R319	A	21	34	6C	4
R13	B	212	51	8C	2	R162	B	125	47	5E	10	R320	A	15	30	5C	4
R14	B	212	53	8B	2	R163	B	146	53	5E	10	R321	A	20	37	6C	4
R15	B	222	50	7C	2	R165	B	99	56	8E	10	R325	B	34	41	6E	4
R16	A	210	40	11C	2	R166	B	104	56	8E	10	R327	A	21	48	7D	4
R17	B	110	30	3F	2	R167	B	102	56	8E	10	R328	A	23	41	7D	4
R20	B	143	17	2D	2	R168	B	106	41	8E	10	R329	B	46	41	6C	4
R21	B	142	29	3D	2	R170	B	88	23	9E	10	R330	A	21	50	7C	4
R22	B	181	17	2D	2	R171	B	85	23	9E	10	R332	B	46	38	7C	4
R23	B	188	29	3D	2	R172	B	85	30	9E	10	R333	A	26	44	7C	4
R24	B	193	17	2C	2	R173	B	86	19	9E	10	R340	B	41	44	8C	4
R25	B	199	27	3C	2	R206	B	171	41	1D	3	R341	B	43	53	8C	4
R26	B	209	27	3C	2	R207	B	82	53	5D	3	R342	B	44	47	8C	4
R27	B	164	17	2C	2	R208	B	72	53	5E	3	R355	B	17	56	9D	4
R28	B	176	33	3C	2	R209	B	54	30	8D	3	R356	B	38	59	10E	4
R29	B	156	17	2B	2	R211	B	70	53	5E	3	R357	B	36	57	10E	4
R30	B	166	29	3B	2	R212	B	82	51	7C	3	R360	B	42	89	11E	4
R31	B	172	17	2B	2	R213	B	68	47	8D	3	R361	B	55	89	11E	4
R32	B	178	33	3B	2	R214	B	74	31	8E	3	R400	B	45	81	2D	5
R33	B	150	17	2B	2	R215	A	60	37	9E	3	R401	B	55	84	2C	5
R34	B	156	30	3B	2	R216	B	60	37	8E	3	R402	B	48	79	2C	5
R35	A	241	21	7A	2	R218	B	71	21	10D	3	R404	A	37	84	4D	5
R36	A	181	17	2C	2	R220	B	64	34	11B	3	R405	A	28	82	4D	5
R38	A	218	43	10C	2	R221	B	67	33	9D	3	R406	A	33	81	4C	5
R41	B	234	29	8E	2	R240	B	55	12	11E	3	R407	A	29	91	4C	5
R42	B	231	29	8E	2	R241	B	66	13	11E	3	R408	B	42	86	3C	5
R43	B	229	29	8E	2	R259	B	79	48	8C	3	R409	B	32	91	4C	5
R44	B	236	29	8E	2	R271	A	168	37	2D	3	R410	A	42	74	4E	5
R45	B	229	14	8E	2	R272	A	161	36	3D	3	R411	A	44	69	4E	5
R46	B	236	14	8E	2	R275	B	156	41	1C	3	R412	A	37	68	4E	5
R47	B	231	14	8E	2	R276	B	173	33	2D	3	R416	B	85	73	6E	5
R48	B	234	14	8E	2	R278	B	171	36	2D	3	R417	B	75	70	6E	5
R49	B	221	30	9E	2	R280	B	129	42	3C	3	R431	A	99	101	10E	5
R50	B	239	32	9E	2	R283	B	119	43	4B	3	R432	A	129	113	10E	5
R51	B	221	28	9E	2	R284	B	121	50	4C	3	R433	A	131	102	10D	5
R52	B	221	25	9E	2	R285	B	115	50	4C	3	R434	A	71	105	10D	5
R53	B	221	15	9E	2	R286	A	91	44	7B	3	R435	A	103	112	10D	5
R54	B	221	23	9E	2	R299	A	60	39	9E	3	R436	A	112	122	10C	5
R55	B	221	18	9E	2	R300	B	42	17	2D	4	R437	A	108	135	10C	5
R56	B	221	20	9E	2	R301	B	39	17	2D	4	R438	A	71	119	10C	5
R116	B	197	49	3F	10	R302	B	37	17	2D	4	R440	A	144	130	10B	5
R117	A	157	63	7A	10	R303	B	34	17	2D	4	R442	A	133	108	11D	5
R119	B	238	47	8B	10	R304	B	32	17	2D	4	R443	A	67	113	11C	5
R120	B	180	48	2F	10	R305	B	29	17	2D	4	R450	A	140	95	11D	5
R121	A	168	51	4E	10	R306	B	27	17	3D	4	R451	A	60	102	11D	5
R122	B	82	60	7E	10	R307	B	24	17	3D	4	R452	A	88	109	11D	5

ROHDE & SCHWARZ	-I	Datum Date	XY-Liste für XY-list for	Sach-Nummer Stock-Nr	Blatt Page
	03	17.06.96	EE AUSGANGSTEIL_2.08GHZ OUTPUT_UNIT_2.08GHZ	1062.7005.01 XY	5+

Part	Side	X	Y	Sqr	Pg	Part	Side	X	Y	Sqr	Pg	Part	Side	X	Y	Sqr	Pg
R453	A	95	119	11D	5	R648	A	241	88	9E	7	R709	A	166	114	3C	8
R454	A	95	135	11C	5	R649	B	247	98	9D	7	R710	A	168	120	4C	8
R455	A	81	114	11C	5	R650	B	89	190	10C	11	R720	A	183	139	3D	8
R500	A	80	83	2F	6	R651	A	187	81	2C	7	R721	A	178	130	4D	8
R501	A	77	83	2F	6	R652	B	184	78	2C	7	R723	B	183	130	4E	8
R502	A	75	83	2F	6	R653	A	206	82	1C	7	R724	B	181	123	4E	8
R503	B	75	83	3E	6	R654	A	202	79	1B	7	R725	A	248	126	10E	8
R520	A	145	113	9F	6	R655	B	245	101	9D	7	R726	A	243	138	10E	8
R521	A	143	113	9F	6	R656	B	91	190	11C	11	R727	A	237	124	10E	8
R522	A	148	113	9F	6	R657	A	221	80	3B	7	R728	A	238	135	10E	8
R530	B	69	93	2C	6	R658	A	223	75	3B	7	R730	B	177	112	5C	8
R600	B	164	79	2D	7	R659	B	95	184	11C	11	R731	B	183	102	6D	8
R601	B	178	82	2E	7	R660	A	190	77	2C	7	R732	B	183	93	7D	8
R602	A	184	79	2E	7	R661	B	34	161	5D	11	R733	A	101	190	11C	11
R603	A	181	75	2E	7	R662	B	39	157	5D	11	R734	A	177	97	6C	8
R604	B	189	72	2D	7	R663	B	19	152	5D	11	R735	A	182	105	6C	8
R605	B	164	73	2D	7	R670	B	115	161	3D	11	R736	A	222	120	10D	8
R607	A	193	83	3D	7	R671	B	119	164	3E	11	R737	A	223	135	10D	8
R608	B	192	74	2D	7	R672	B	71	164	4D	11	R738	A	76	187	10E	11
R609	B	187	82	2D	7	R673	B	84	164	4E	11	R739	B	98	188	12C	11
R611	A	180	64	4C	7	R674	B	50	150	4D	11	R740	B	194	134	8D	8
R612	A	178	67	3C	7	R675	B	41	147	5C	11	R741	A	194	134	9D	8
R613	A	197	66	3C	7	R676	B	47	151	5D	11	R742	A	191	135	9D	8
R614	A	194	77	3C	7	R677	B	17	155	6C	11	R743	A	191	129	9E	8
R615	A	197	77	3C	7	R678	B	17	164	6C	11	R745	B	210	124	9C	8
R616	A	202	69	2B	7	R679	B	21	158	6D	11	R747	A	217	130	11D	8
R618	A	194	86	2C	7	R680	B	36	171	7D	11	R748	A	216	124	11D	8
R619	B	198	79	2C	7	R681	B	46	174	7E	11	R750	A	208	130	11E	8
R620	A	196	81	2B	7	R682	B	49	185	7D	11	R751	A	201	123	11E	8
R621	B	231	80	5E	7	R683	B	63	187	8D	11	R753	A	201	133	11E	8
R622	B	186	69	3E	7	R684	B	65	187	8D	11	R754	A	196	120	11E	8
R623	B	231	77	6E	7	R685	A	48	190	8E	11	R755	A	203	126	11E	8
R624	B	231	74	6E	7	R686	A	42	187	8E	11	R760	B	228	121	11C	8
R625	B	231	72	6E	7	R687	B	75	182	9C	11	R761	B	236	109	11C	8
R626	B	228	69	6D	7	R688	B	83	190	8C	11	R762	A	182	113	7E	8
R627	B	230	66	6D	7	R689	A	79	190	9C	11	R765	B	100	185	2E	12
R628	B	230	64	6D	7	R690	B	70	189	9C	11	R766	A	100	177	2D	12
R629	B	186	67	3E	7	R691	B	53	172	10C	11	R767	A	113	181	2C	12
R630	B	264	24	5C	7	R692	A	75	177	9C	11	R768	B	119	182	2D	12
R631	B	264	15	5B	7	R693	A	69	172	10C	11	R769	A	104	171	2D	12
R632	B	241	64	6D	7	R694	A	70	182	9C	11	R770	B	119	180	3D	12
R633	A	212	63	2C	7	R695	A	58	175	10C	11	R771	A	111	174	3C	12
R634	B	264	21	5C	7	R696	A	89	183	10C	11	R772	B	109	185	3D	12
R635	A	206	72	2A	7	R697	A	91	183	11C	11	R773	A	118	185	3C	12
R636	A	206	74	2B	7	R698	A	83	178	10C	11	R774	B	121	188	3C	12
R637	A	213	85	3B	7	R699	A	89	173	11C	11	R776	B	124	182	4E	12
R638	A	213	83	3A	7	R700	B	154	111	2D	8	R777	B	135	185	4E	12
R639	A	217	83	3A	7	R701	B	154	121	2D	8	R779	A	187	149	6C	12
R640	B	258	46	6C	7	R702	B	153	124	3D	8	R780	A	232	166	6B	12
R641	B	269	69	8D	7	R703	B	225	138	10C	8	R781	A	191	156	6C	12
R642	B	243	67	7D	7	R704	A	150	126	2D	8	R782	A	207	179	6B	12
R644	B	264	88	8D	7	R705	A	142	122	3E	8	R783	A	172	168	6C	12
R645	B	252	80	9D	7	R706	B	169	128	4C	8	R784	A	205	187	6B	12
R646	B	249	79	9D	7	R707	B	169	118	4C	8	R785	B	197	148	6E	12
R647	B	241	81	9E	7	R708	B	215	138	10C	8	R786	B	197	154	6D	12

ROHDE & SCHWARZ	-I	Datum Date	XY-Liste für XY-list for	Sach-Nummer Stock-Nr	Blatt Page
		03 17.06.96	EE AUSGANGSTEIL_2.08GHZ OUTPUT_UNIT_2.08GHZ	1062.7005.01 XY	6+

Part	Side	X	Y	Sqr	Pg	Part	Side	X	Y	Sqr	Pg	Part	Side	X	Y	Sqr	Pg
R787	B	168	170	7C	12	R850	A	288	110	5B	9	V404	A	23	77	4C	5
R788	B	203	190	8C	12	R851	B	293	93	5B	9	V405	A	22	91	4C	5
R789	B	206	179	8D	12	R852	A	295	89	5B	9	V410	B	54	72	6D	5
R790	B	234	164	8E	12	R853	B	285	75	8D	9	V411	A	40	66	4E	5
R791	B	276	182	11E	12	R854	A	287	72	5B	9	V431	A	102	95	11E	5
R792	B	273	189	11E	12	R855	A	287	70	6B	9	V432	A	124	95	11E	5
R793	A	140	182	5D	12	R856	A	277	26	7B	9	V433	A	132	96	11D	5
R794	A	142	182	5A	12	R857	A	288	41	7B	9	V434	A	65	103	11D	5
R800	B	271	147	2D	9	R858	A	291	112	5B	9	V435	A	96	109	11D	5
R801	B	263	158	3D	9	R859	A	288	107	5B	9	V436	A	106	118	11C	5
R802	A	275	149	2E	9	R860	B	283	75	8D	9	V437	A	101	134	11C	5
R803	A	262	148	3E	9	R861	A	295	43	8B	9	V438	A	75	115	11C	5
R804	A	276	161	3E	9	R862	A	283	79	5C	9	V500	B	71	84	2E	6
R805	A	265	158	3E	9	R863	A	295	46	8B	9	V511	B	99	77	4E	6
R806	A	271	169	3F	9	R866	A	277	47	6C	9	V512	B	103	77	5E	6
R807	A	261	166	3F	9	R867	B	283	32	7C	9	V514	B	109	75	6E	6
R808	B	286	107	7D	9	R868	A	277	35	7C	9	V515	B	123	77	6E	6
R809	B	294	130	5D	9	R869	A	282	41	8C	9	V516	B	131	75	7E	6
R810	A	297	138	5E	9	R870	A	278	87	9B	9	V520	B	144	101	9E	6
R811	A	290	138	5E	9	R871	A	278	90	10B	9	V523	B	143	107	9D	6
R812	A	282	138	5E	9	R872	A	300	79	11B	9	V530	B	67	87	1C	6
R813	B	288	130	5D	9	R873	A	296	84	11B	9	V532	B	63	98	1B	6
R815	B	291	127	5D	9	R874	A	296	76	11C	9	V535	B	63	105	3B	6
R816	B	274	110	6D	9	R875	A	300	71	10C	9	V536	B	70	113	3B	6
R817	B	294	120	6D	9	R876	A	281	84	10B	9	V539	B	72	121	5B	6
R818	B	284	117	6D	9	R880	B	288	92	7E	9	V540	B	78	124	5B	6
R819	B	282	101	7D	9	R882	A	293	160	7F	9	V543	B	82	125	7B	6
R820	A	278	107	7E	9	R887	A	264	136	10E	9	V544	B	96	127	7B	6
R821	A	297	178	6E	9	R889	B	276	83	8D	9	V548	B	96	123	10E	6
R822	A	295	164	7E	9	R898	B	286	24	9C	9	V600	B	175	82	2E	7
R823	A	281	164	7F	9	R899	A	280	27	7B	9	V602	B	170	71	2D	7
R824	A	278	169	7F	9	U600	B	258	56	6D	7	V604-A	B	187	72	2D	7
R825	A	281	167	8E	9	U666	B	34	154	5D	11	V604-B				2D	7
R826	A	290	160	7F	9	V11	B	219	46	7C	2	V606-A	A	203	64	3C	7
R827	A	278	172	7F	9	V12	B	217	53	8C	2	V606-B				2B	7
R828	B	288	120	6D	9	V13	A	215	36	10C	2	V608	A	199	62	3C	7
R829	B	285	72	9D	9	V14	B	107	30	3F	2	V610	B	260	85	8D	7
R830	B	281	66	9D	9	V15	B	105	34	3F	2	V612	B	242	95	9D	7
R831	A	278	72	9E	9	V25	B	209	29	3C	2	V635	A	213	80	3A	7
R832	A	266	120	9E	9	V26	B	203	29	3C	2	V636	B	202	85	3A	7
R834	A	262	123	9E	9	V35	A	241	11	6A	2	V656	A	206	64	2B	7
R835	A	267	135	9F	9	V110	B	225	51	8B	10	V670	B	117	151	2D	11
R836	A	268	132	9F	9	V130	B	120	56	10C	10	V671	B	79	151	3D	11
R837	A	255	129	9F	9	V134	B	248	169	10B	10	V680	A	65	187	9B	11
R838	A	252	126	9F	9	V200	A	68	24	10D	3	V681	A	53	178	10B	11
R839	B	286	65	9D	9	V310	B	21	30	5D	4	V682	A	85	187	10B	11
R841	B	291	16	11D	9	V315	B	21	44	7D	4	V683	A	96	187	11B	11
R842	B	289	16	11D	9	V318	A	17	23	5C	4	V700-A	B	157	117	2D	8
R843	B	295	19	11D	9	V319	A	26	32	6C	4	V700-B				2D	8
R844	B	281	20	9C	9	V330	A	17	51	7C	4	V705	B	169	134	4C	8
R845	B	281	23	8B	9	V333	A	20	44	7C	4	V707	B	169	104	5C	8
R846	B	280	30	8C	9	V335	B	80	39	8C	3	V715	A	231	124	10D	8
R847	A	267	126	9F	9	V336	B	79	35	8C	3	V716	A	232	135	10D	8
R848	B	286	36	8C	9	V337	B	76	37	9C	3	V717	A	225	120	10D	8
R849	B	276	57	10D	9	V400	B	33	80	4D	5	V718	A	225	139	10D	8

ROHDE & SCHWARZ	-I	Datum Date	XY-Liste für XY-list for	Sach-Nummer Stock-Nr	Blatt Page
	03	17.06.96	EE AUSGANGSTEIL_2.08GHZ OUTPUT_UNIT_2.08GHZ	1062.7005.01 XY	7+

Part	Side	X	Y	Sqr	Pg	Part	Side	X	Y	Sqr	Pg	Part	Side	X	Y	Sqr	Pg
V720	B	182	136	4D	8	V787	B	222	186	8D	12	V875-B				8E	11
V725	B	183	116	5E	8	V801	B	284	157	4D	9	V876	B	84	175	11D	11
V730	B	181	109	6D	8	V802	A	277	149	2E	9	V877	B	75	175	9D	11
V735	B	190	96	7D	8	V803	A	262	156	3E	9	VC1	B	126	36	4E	2
V745	A	215	134	11D	8	V804	A	275	159	3E	9	VC2	B	116	35	4E	2
V746	A	213	120	12D	8	V805	A	265	156	3E	9	W1A	B	210	135	10B	8
V747	A	210	128	11E	8	V814	A	284	160	7F	9	W1B	B	210	135	1D	11
V748	A	207	123	11E	8	V815	A	298	169	7E	9	X2A	B	189	11	2C	2
V750	A	193	124	11E	8	V816	A	289	174	7E	9	X2B	B	189	11		
V751	A	196	126	11E	8	V817	B	284	101	7D	9	X205	B	70	40	10B	3
V752	A	200	130	11E	8	V827	A	261	126	9F	9	X224	B	17	15	1D	4
V753	A	191	124	11E	8	V828	A	287	167	8F	9	X225	B	258	15	5B	7
V765	A	113	184	2C	12	V829	A	285	169	7F	9	X226	B	283	15	12D	9
V766	A	119	173	3C	12	V830	A	264	116	9E	9	Z1	B	118	20	2E	2
V768	B	103	173	2D	12	V831	A	256	116	9E	9	Z2	B	131	17	2E	2
V769	B	123	175	4D	12	V832	B	283	65	9D	9	Z3	B	100	20	2D	2
V770	B	183	148	6E	12	V833	A	259	135	9F	9	Z4	B	141	20	2D	2
V771	B	183	157	6D	12	V834	A	257	138	10F	9	Z5	B	187	20	2D	2
V772	B	172	163	6D	12	V844-A	B	286	26	8C	9	Z6	B	194	20	2C	2
V773	B	237	177	8E	12	V844-B				7C	9	Z7	B	169	20	2C	2
V774	B	214	179	8D	12	V850-A	A	285	45	7B	9	Z8	B	164	20	2B	2
V775	B	214	186	8D	12	V850-B				6B	9	Z9	B	174	20	2B	2
V780	B	265	183	11D	12	V853	A	291	77	6C	9	Z10	B	146	20	2B	2
V782	B	174	148	6E	12	V857	A	288	30	7B	9	Z11	B	113	20	2F	2
V783	B	175	150	6D	12	V870	A	277	92	10B	9	Z20	B	126	17	2E	2
V784	B	172	151	6D	12	V871	B	271	112	10B	9	Z700	B	222	149	7E	12
V785	B	224	183	8E	12	V874	B	35	181	6D	11	Z710	B	197	164	7D	12
V786	B	222	184	8D	12	V875-A	B	58	186	8D	11	Z720	B	174	178	7D	12

ROHDE & SCHWARZ	-I	Datum Date	XY-Liste für XY-list for	Sach-Nummer Stock-Nr	Blatt Page
	03	17.06.96	EE AUSGANGSTEIL_2.08GHZ OUTPUT_UNIT_2.08GHZ	1062.7005.01 XY	8-



ROHDE & SCHWARZ

Stromläufe
Bestückungspläne
Circuit diagrams
Components plans
Schémas de circuit
Plans des composants

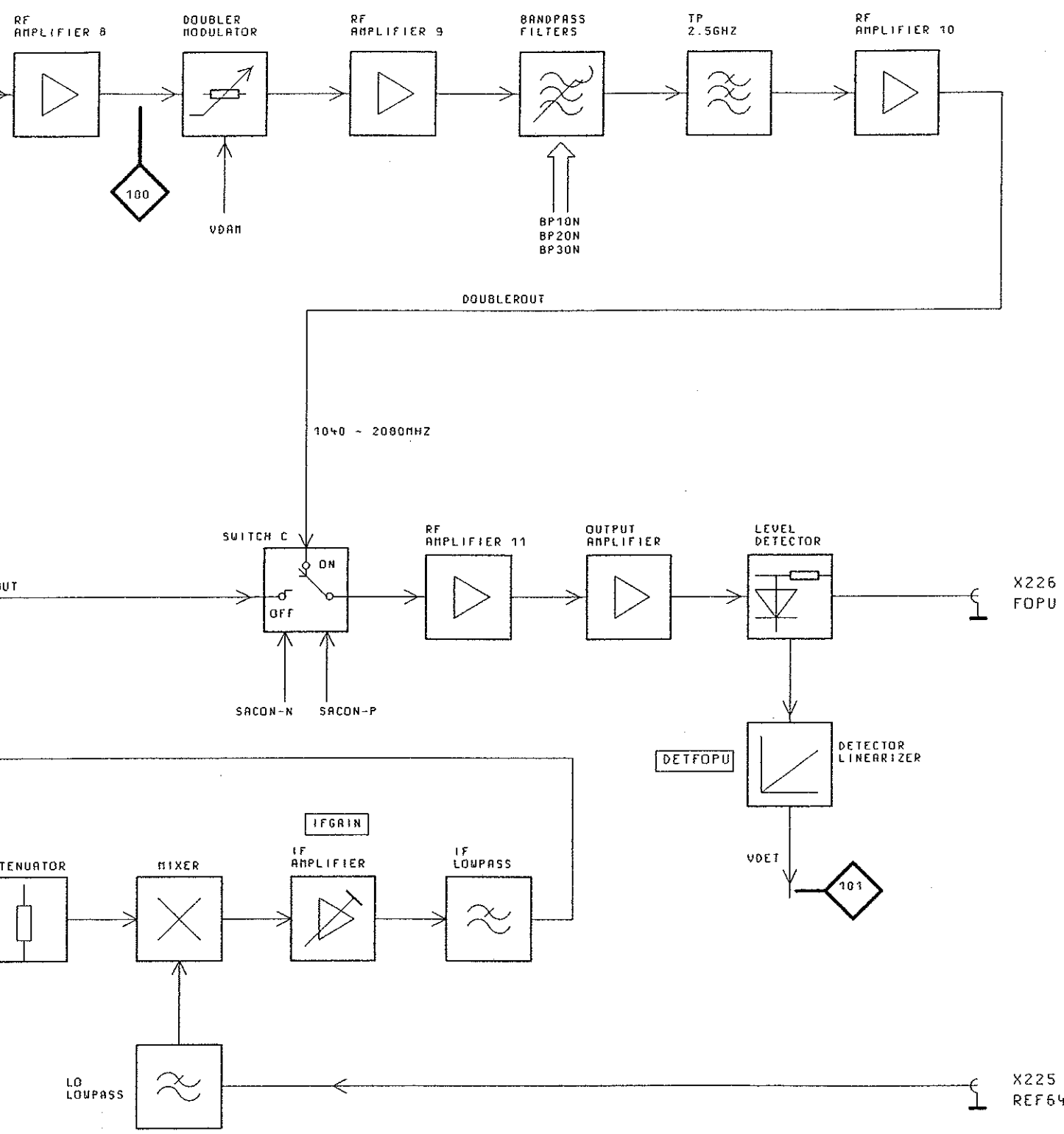

04/02		03.03.97	E I	MENP	TAG	NAME	BENENNUNG			
				BEARB.		E I	AUSGANGSTEIL 2.08GHZ OUTPUT UNIT 2.08GHZ			
				GEPR.						
				NORM						
				PLOTT	03.03.97					
04/01		16.12.96	E I	 ROHDE & SCHWARZ	ZEICHN.-NR.		1062.7005.015	BLATT-NR.		
REND. IND.	ÄNDERUNGS-MITTEILUNG	DATUM	NAME		ZU GERÄT	SMY		REG. I. V.	1062.5502	ERSTE Z.

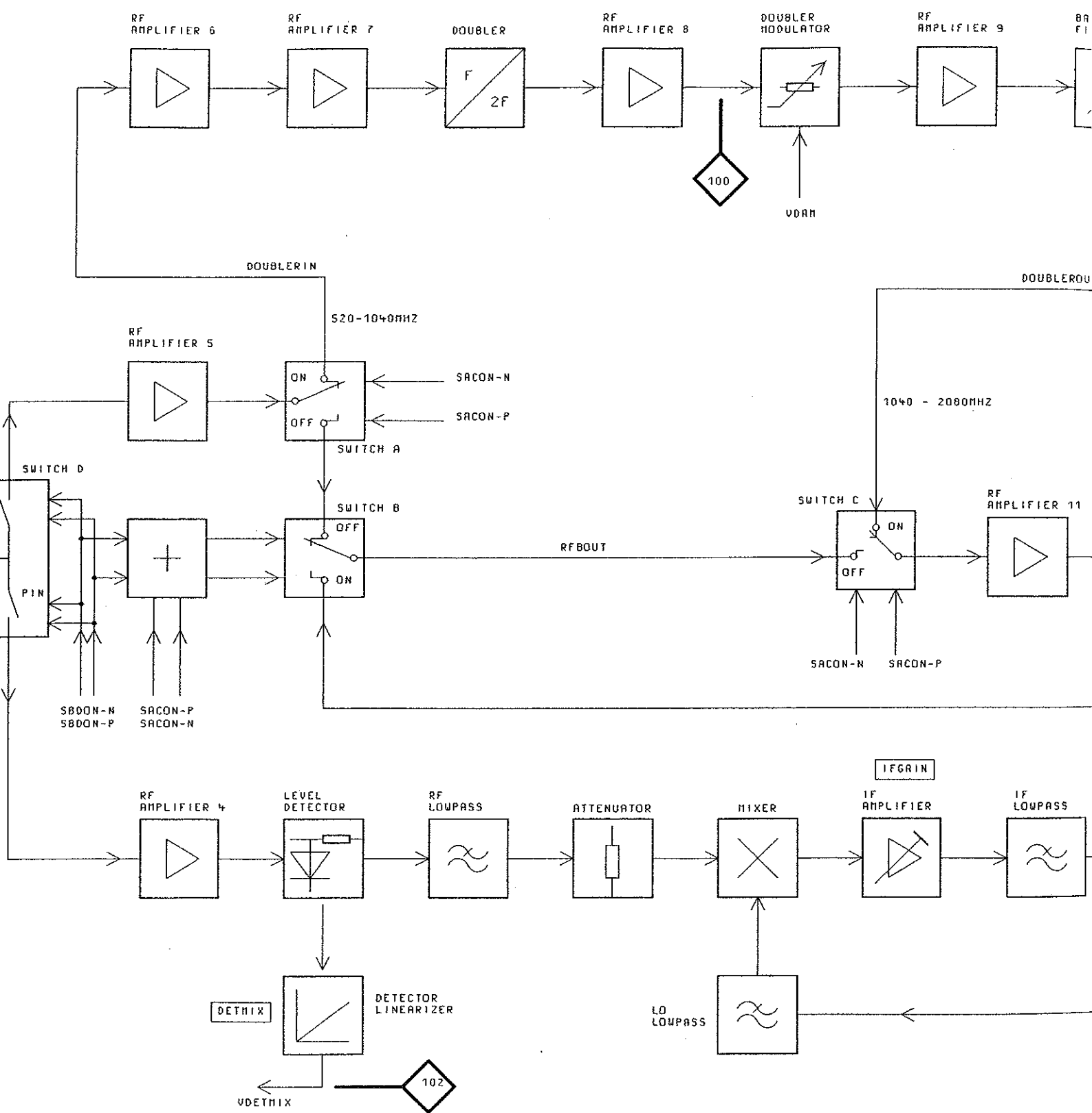

EN UEBER VARIANTEN,
 BEWERTUNG UND
 TE BAUTEILE SIEHE SA.
 INFORMATION ON MODELS,
 COMPONENTS VALUES AND
 PARTS LIST.



ACHTUNG: ESB!
 ELEKTROSTATISCH GEFÄHRDETE
 BAUELEMENTE ERFORDERN EINE
 BESONDERE HANDHABUNG.
ATTENTION ESD!
 ELECTROSTATIC SENSITIVE DEVICES
 REQUIRE A SPECIAL HANDLING

04/02		03.03.97	E I	MENP	TAG
				BEARB.	
				GEPR.	
				NDRH	
				PLOTT	03.03.97
04/01		16.12.96	E I		
REND. IND.	RENDERUNGS-NITTEILUNG	DATUM	NAME	 ROHDE & SCH ZU GERÄT SMY	

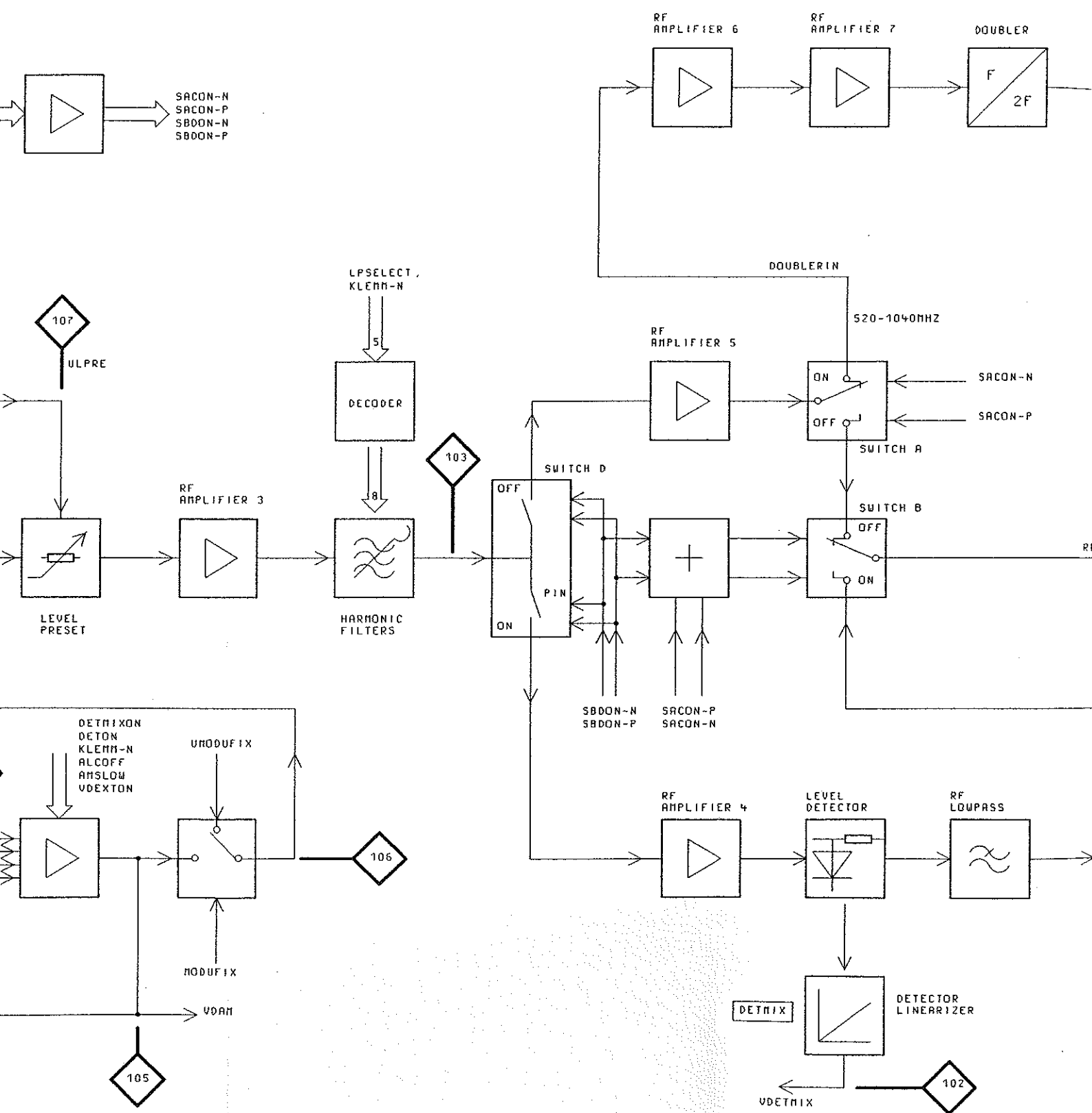

BINDENDE ANGABEN UEBER VARIANTEN,
 TRIMMWERTE, BAUTEILWERTE UND
 NICHT BESTUECKTE BAUTEILE SIEHE SA.
 FOR BINDING INFORMATION ON MODELS,
 TRIMMING AND COMPONENTS VALUES AND
 NONFITTED COMPONENTS SEE PARTS LIST.

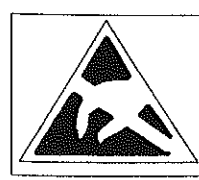

ACHTUNG: ESB!
 ELEKTROSTATISCH GEFAEHRDETE
 BAUELEMENTE ERFORDERN EINE
 BESONDERE HANDHABUNG.
 ATTENTION ESD!
 ELECTROSTATIC SENSITIVE DEVICES
 REQUIRE A SPECIAL HANDLING

AMINVERS
 HFINTENABE
 BLANKINVERS
 BLANKENABE
 AM
 LPRE
 RFLEV
 LPSELECT
 SB00N
 SACON
 BP10N
 BP20N
 BP30N
 MODUFIX
 DETNIXON
 VDEXTON
 DETON
 RFLEVENABE
 ALCOFF
 ANSLOW

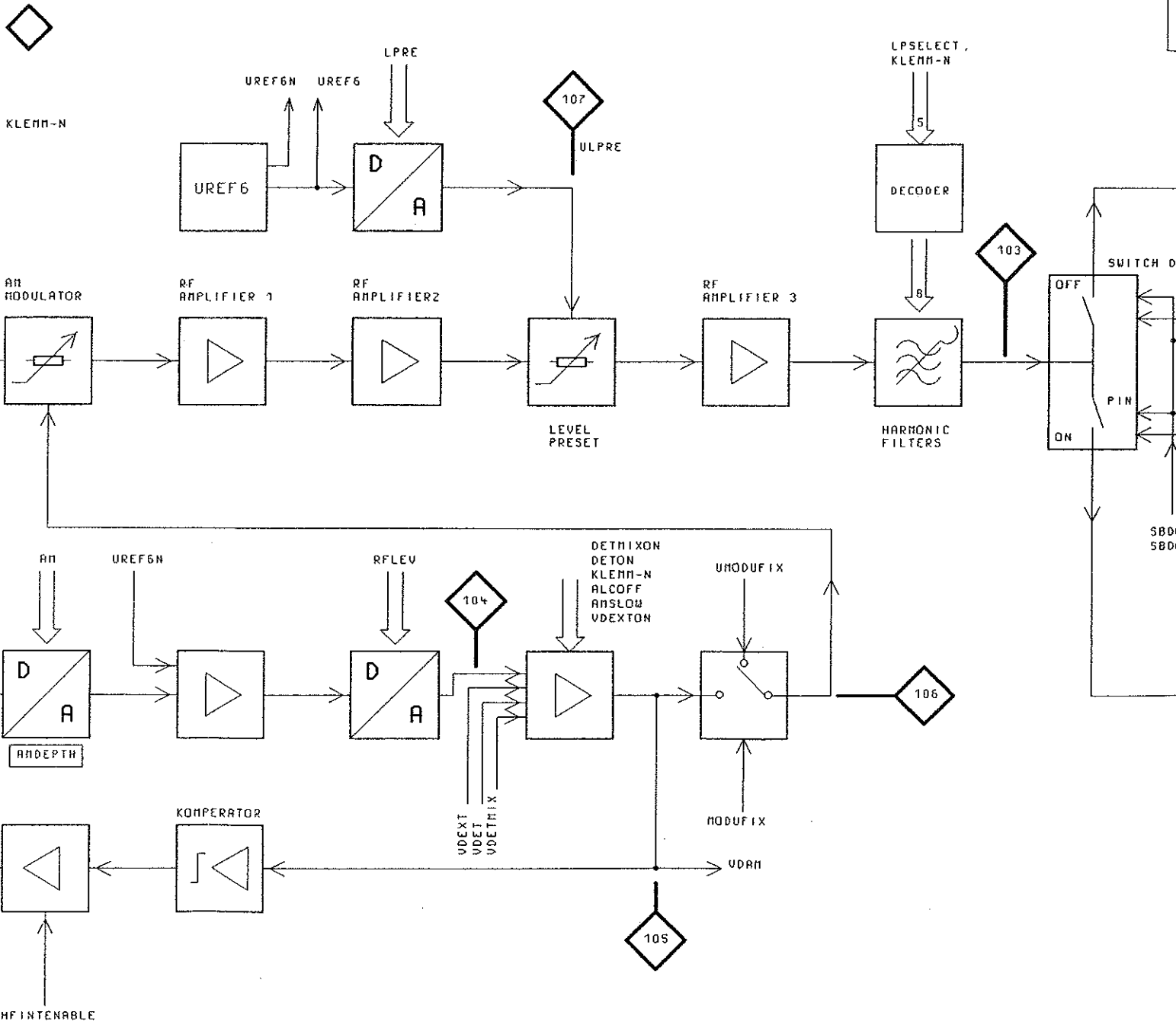
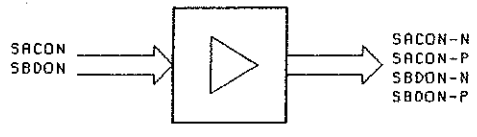

BINDENDE ANGABEN UEBER VARI
 TRIMMWERTE, BAUTEILWERTE UN
 NICHT BESTUECKTE BAUTEILE S
 FOR BINDING INFORMATION ON
 TRIMMING AND COMPONENTS VAL
 NONFITTED COMPONENTS SEE PA

X2

11, 13, 18,
20, 21, 23,
27, 29, 31

GND

22 → UA24-P → +24V
24, 25 → UA15-P → +15V
28 → UA5-P → +5V
30 → UA15-N → -15V

AMINVERS
HFINTENABLE
BLANKINVERS
BLANKENABLE
AM
LPRE
RFLEV
RFLEVEV
LPSELECT
SB00N
SACON
BP10N
BP20N
BP30N
MODU FIX
DETRIXON
VDEXTON
DETON
RFLEVENABLE
ALCOFF
ANSLOW



DIAG
DIAGON

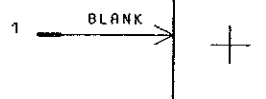
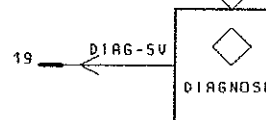

BLANKINVERS
BLANKENABLE
RFLEVENABLE

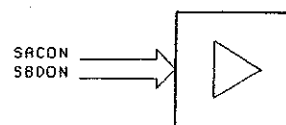

SACON-N
SACON-P
SB00N-N
SB00N-P

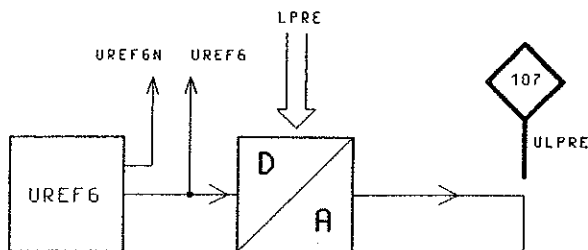

X224
FSYN

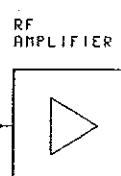
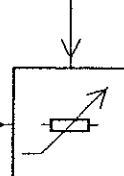
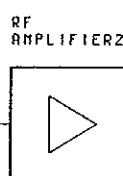
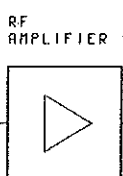
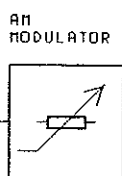
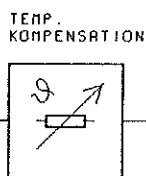

5 → VDEXT

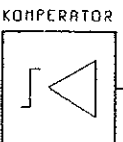
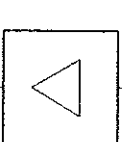
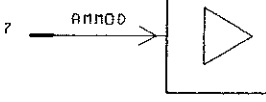
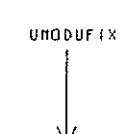
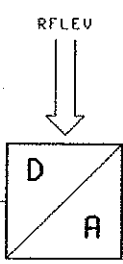
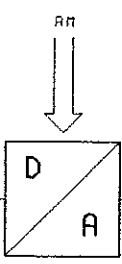

7 → AMMOD

17 → HFINT

HFINTENABLE



BEHALTEN DIR UNS ALLE RECHTE VOR

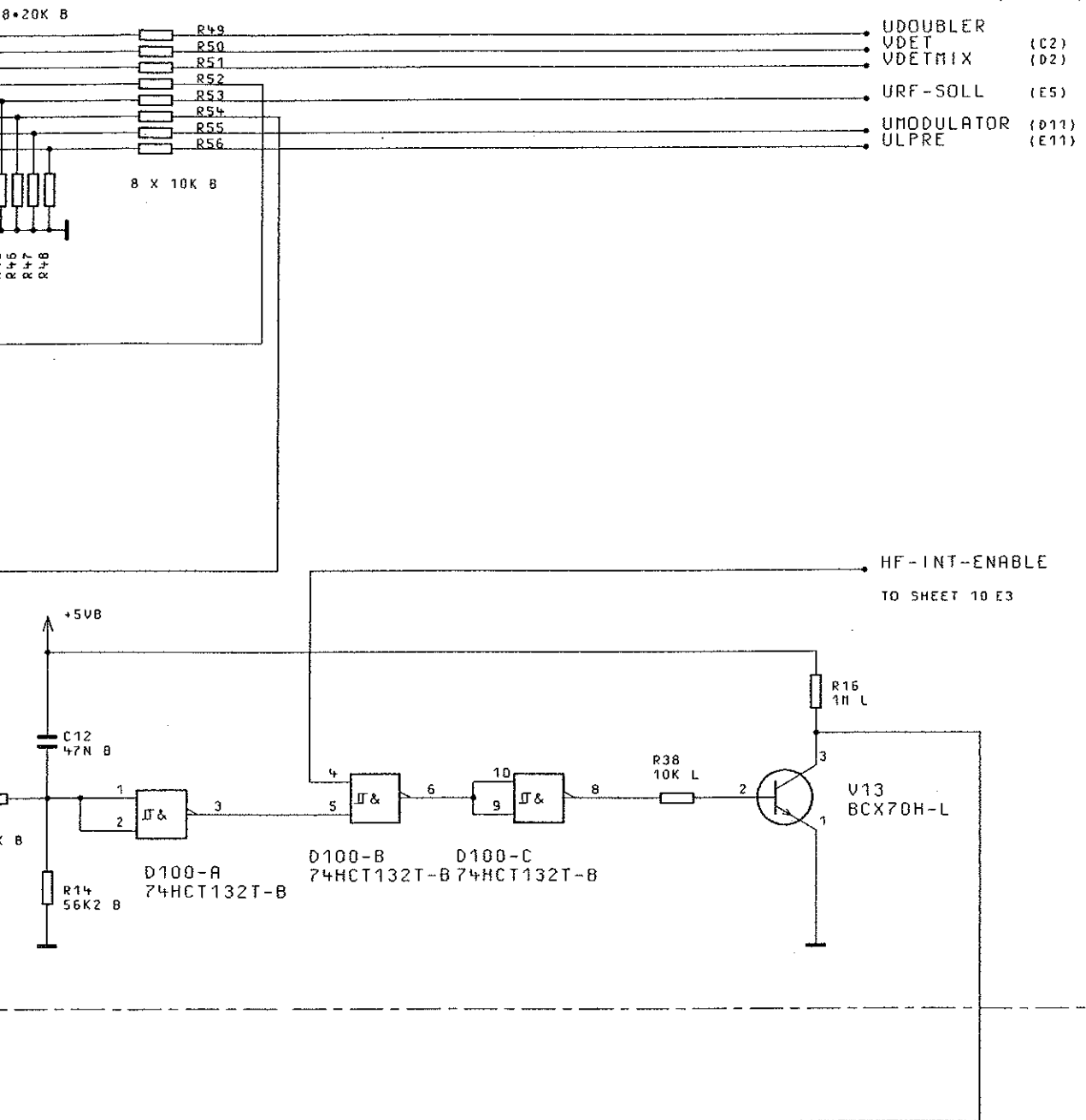

BECKT
BINDENDE ANGABEN UEBER VARIANTEN,
TRIMMWERTE, BAUTEILWERTE UND
NICHT BESTUECKTE BAUTEILE SIEHE SA.

FOR BINDING INFORMATION ON MODELS,
TRIMMING AND COMPONENTS VALUES AND
NONFITTED COMPONENTS SEE PARTS LIST.

04/02		03.03.97	E I	MENP	TAG	NAME	BENENNUNG		
				BEARB.		E I	AUSGANGSTEIL 2.08GHZ		
				GEPR.			OUTPUT UNIT 2.08GHZ		
				NORM					
				PLOTT	03.03.97				
04/01		16.12.96	E I	ROHDE & SCHWARZ			ZEICHN.-NR.	BLATT-NR.	
REND. IND.	RENDERUNGS- MITTEILUNG	DATUM	NAME				1062.7005.01S	2+	
				ZU GERÄT	SMY	REG.-I.V.	1062.5502	ERSTE Z.	1062.5502

9

10

11

12

DIAGNOSE

SHEET 10/E3

D10-A
74HCT4051T-B

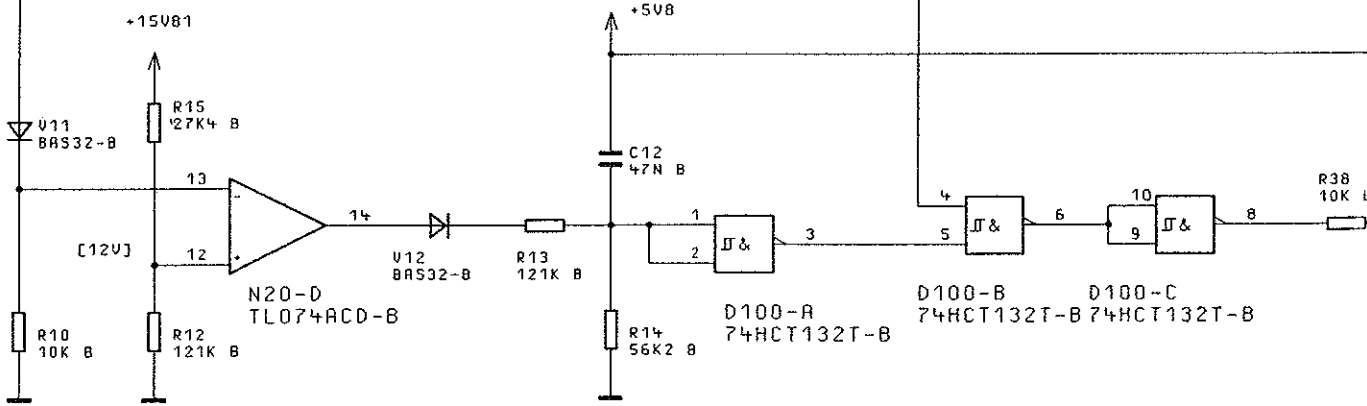
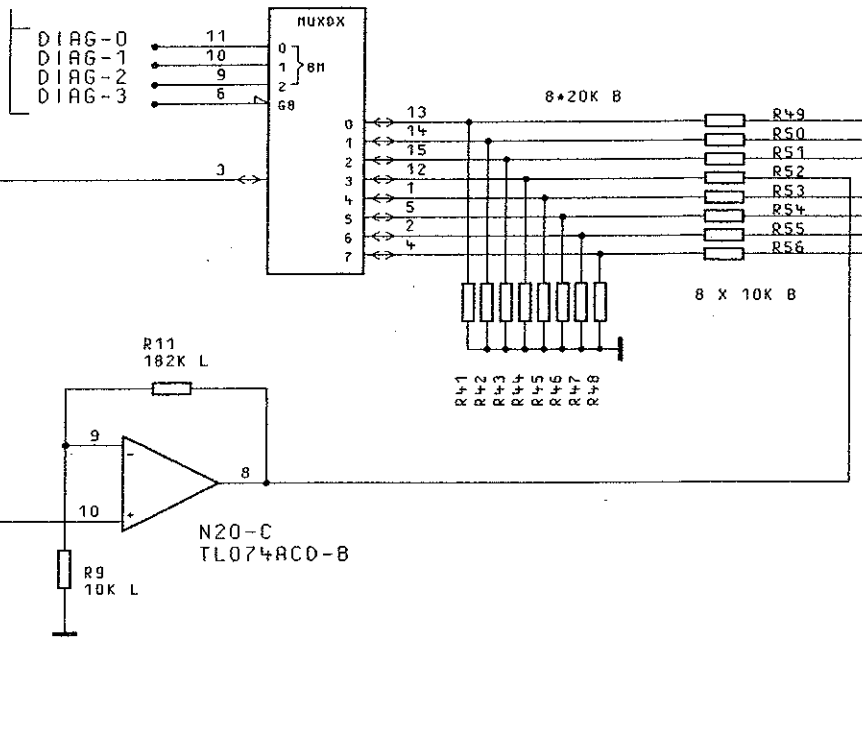

74051T-B

N.F. - NOT FITTED / NICHT BESTUECKT

BINDENDE ANGABEN UEBER VARIANTEN,
TRIMMWERTE, BAUTEILWERTE UND
NICHT BESTUECKTE BAUTEILE SIEHE SA.

FOR BINDING INFO
TRIMMING AND COM
NONFITTED COMPON

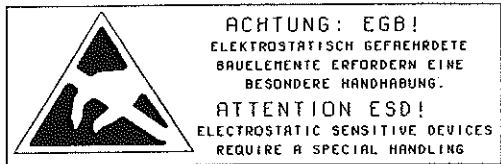
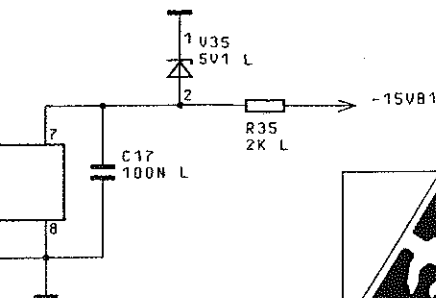

04/02		03.03.97	E I	MENP	TAG	NAM
				BEARB.		E
				GEPR.		
				NDRH		
				PLOTT	03.03.97	
04/01		16.12.96	E I			
REND. IND.	RENDERUNGS- MITTEILUNG	DATUM	NAME	 ROHDE&SCHWA ZU GERBET SMY		

TEXT

5V81
5V83
5V84

5V81
5V83
5V84

+VH

VB

DIAGNOSE

SHEET 10/E3

D10-A
74HCT4051T-B

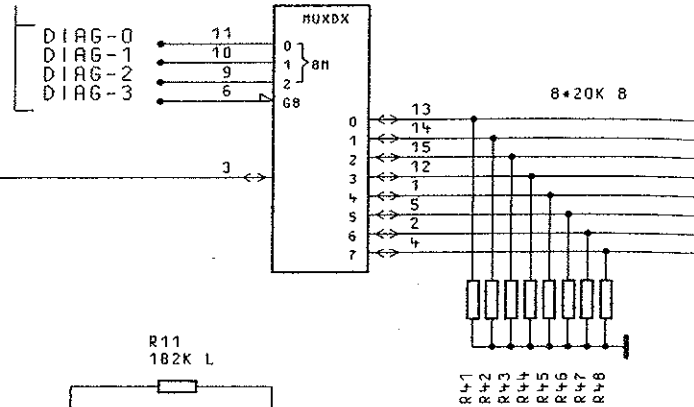

DETFILT

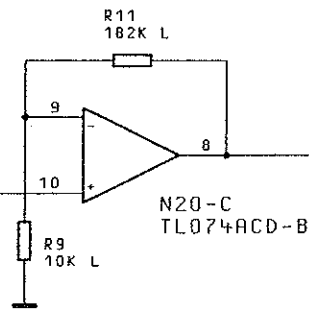

UREGELVERST

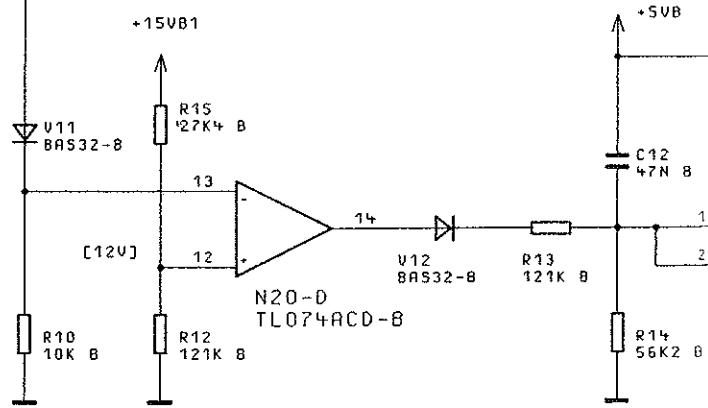

N.F. = NOT FITTED / NICHT BESTUECKT

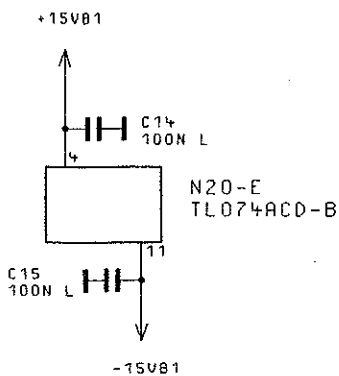

D10-B
74HCT4051T-B

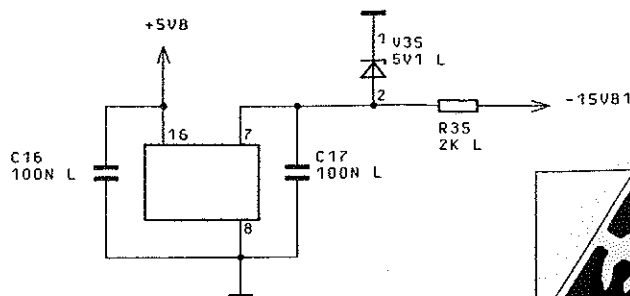

ACHTUNG: EGB!
ELEKTROSTATISCH GEFÄHRDETE
BAUELEMENTE ERFORDERN EINE
BESONDERE HANDHABUNG.
ATTENTION ESD!
ELECTROSTATIC SENSITIVE DEVICES
REQUIRE A SPECIAL HANDLING

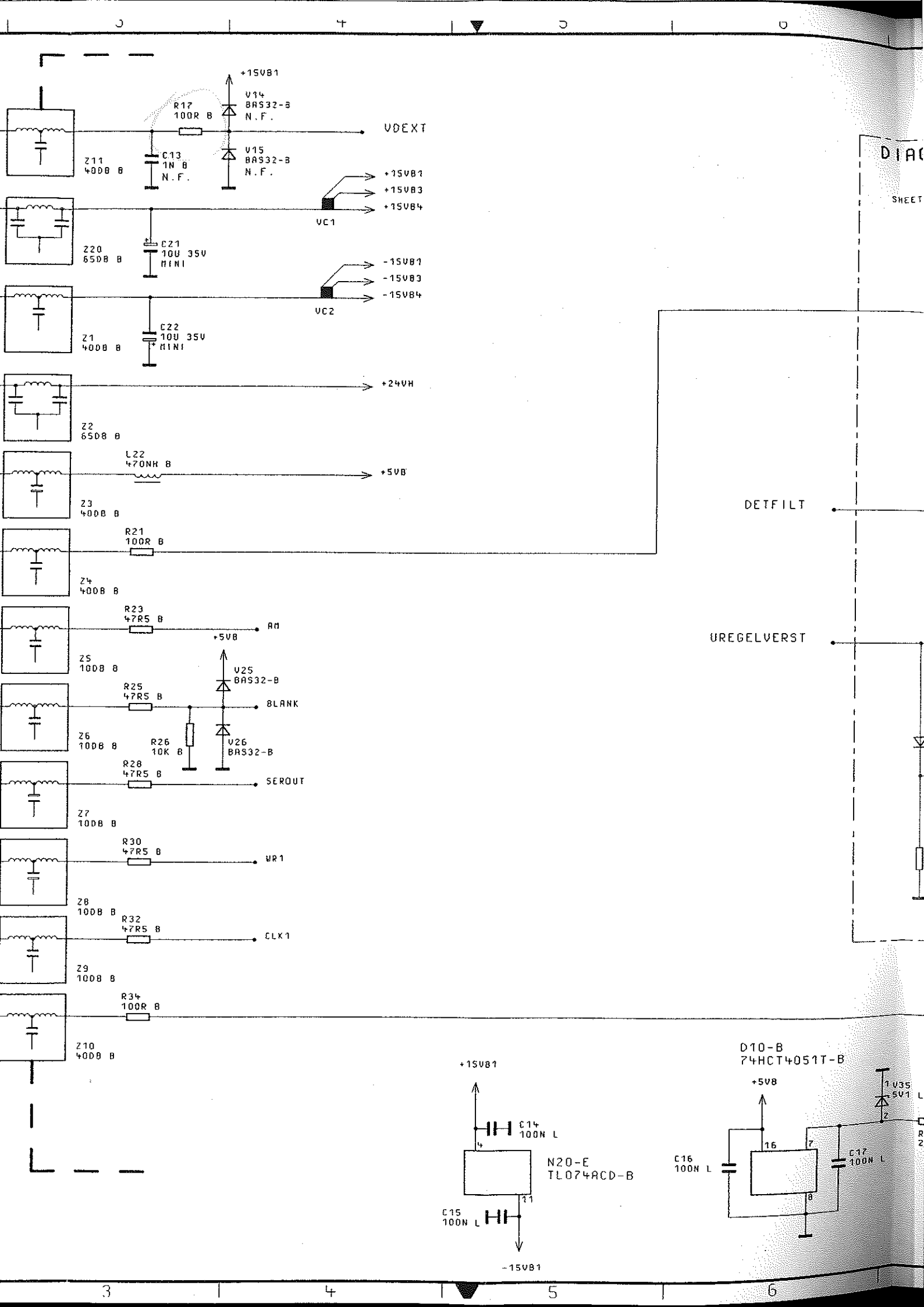

BEHALTEN MIR UNS ALLE RECHTE VOR
FUER DIESE UNTERLAGE

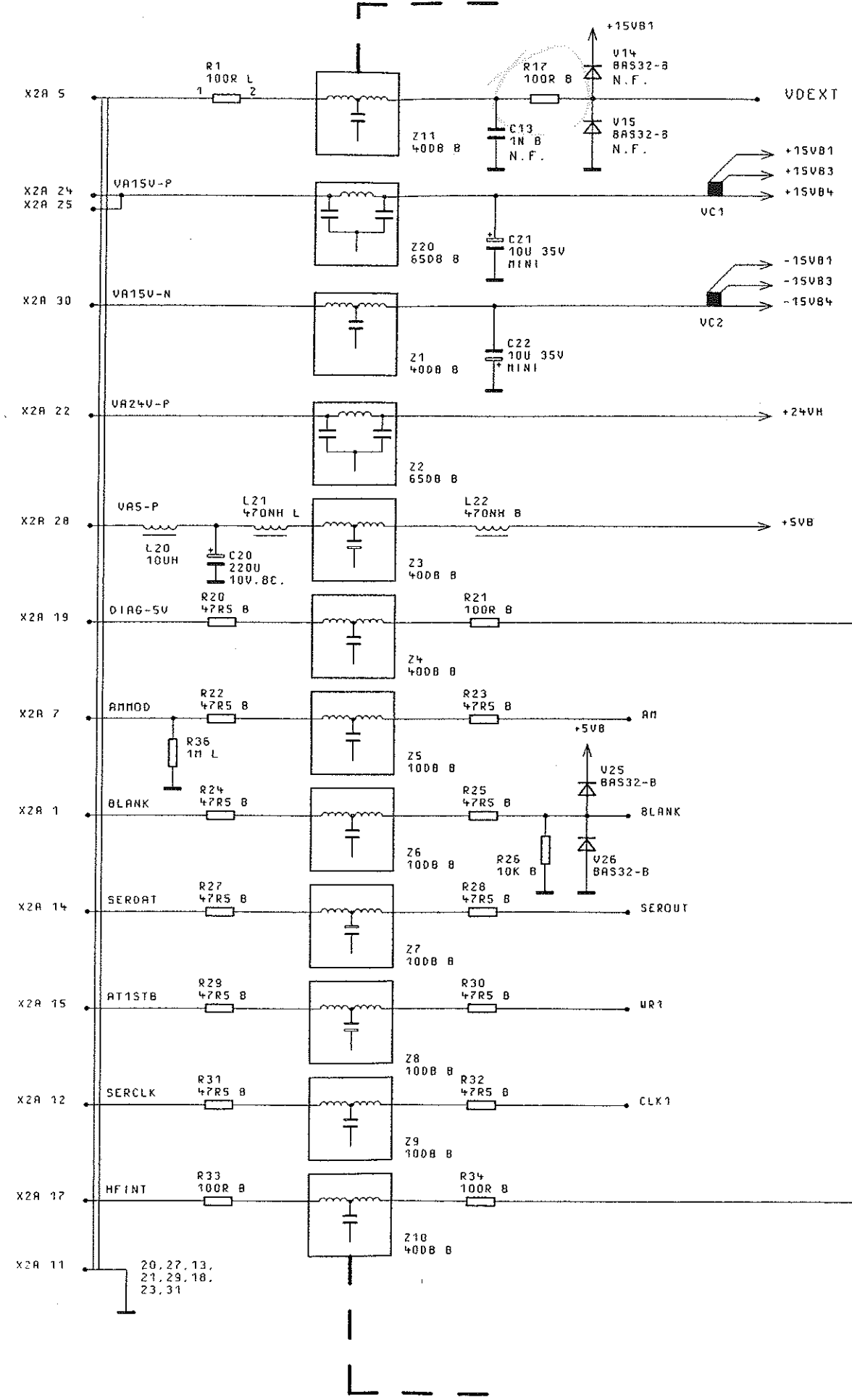

20, 27, 13,
21, 29, 18,
23, 31

C15
100N L

P306
P305

P352

P353

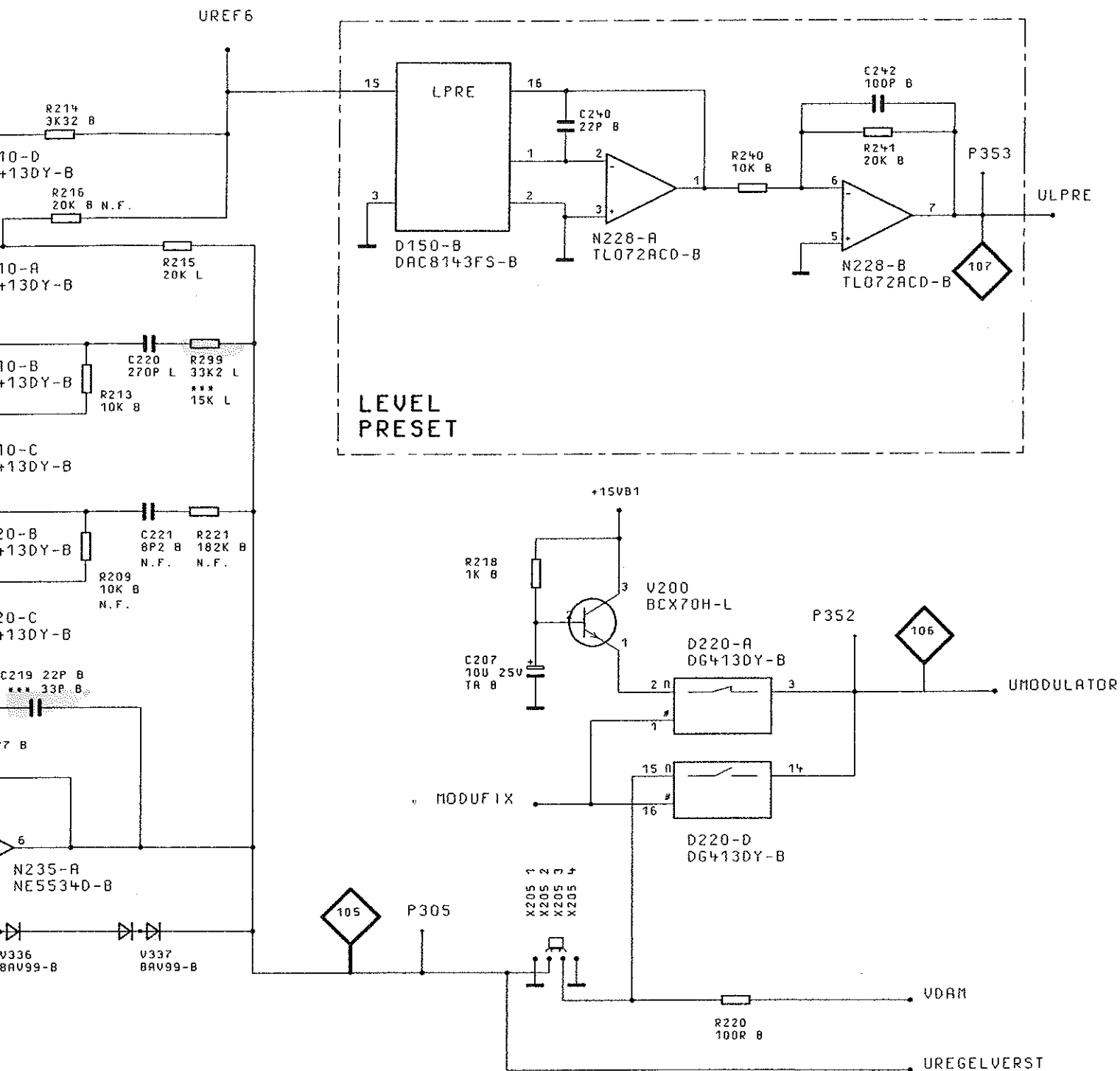

N.F. - NOT FITTED / NICHT BESTUECKT

-B
2ACD-B

** - VAR. 04 / MOD. 04

*** - MIT/WITH OPTION SHY-B40

BINDENDE ANGABEN UEBER VARIANTEN,
TRIMMWERTE, BAUTEILWERTE UND
NICHT BESTUECKTE BAUTEILE SIEHE SA.

FOR BINDING INFORMATION ON MODELS,
TRIMMING AND COMPONENTS VALUES AND
NONFITTED COMPONENTS SEE PARTS LIST.

04/02	03.03.97	E I	MENP	TAG	NAME	BENENNUNG			
			BEARB.		E I	AUSGANGSTEIL 2.08GHZ OUTPUT UNIT 2.08GHZ			
			GEPR.						
			NORM						
			PLOTT	03.03.97					
04/01	16.12.96	E I	 ROHDE&SCHWARZ		ZEICHN.-NR.	BLATT-NR. 3+			
REND. IND.	ÄNDERUNGS- MITTEILUNG	DATUM	NAME	ZU GERÄT	SHY	REG. I. V.	1062.5502	ERSTE Z.	1062.5502

B!
BEHÖRDE
FÜR EINE
ÄNDERUNG.
D!
ÄNDERUNG
VON BAUTEILEN
UND ANDEREN
ÄNDERUNGEN

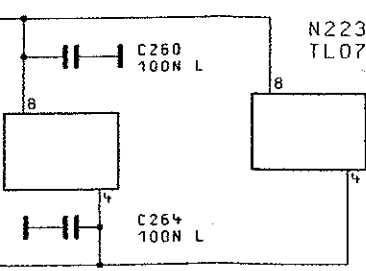
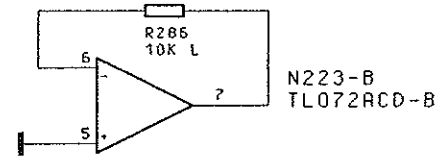
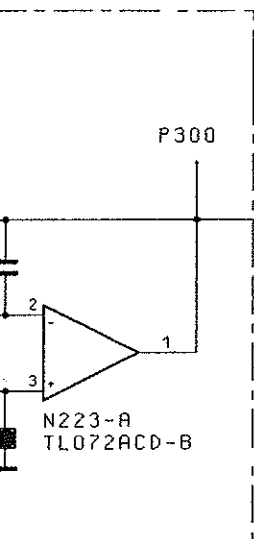
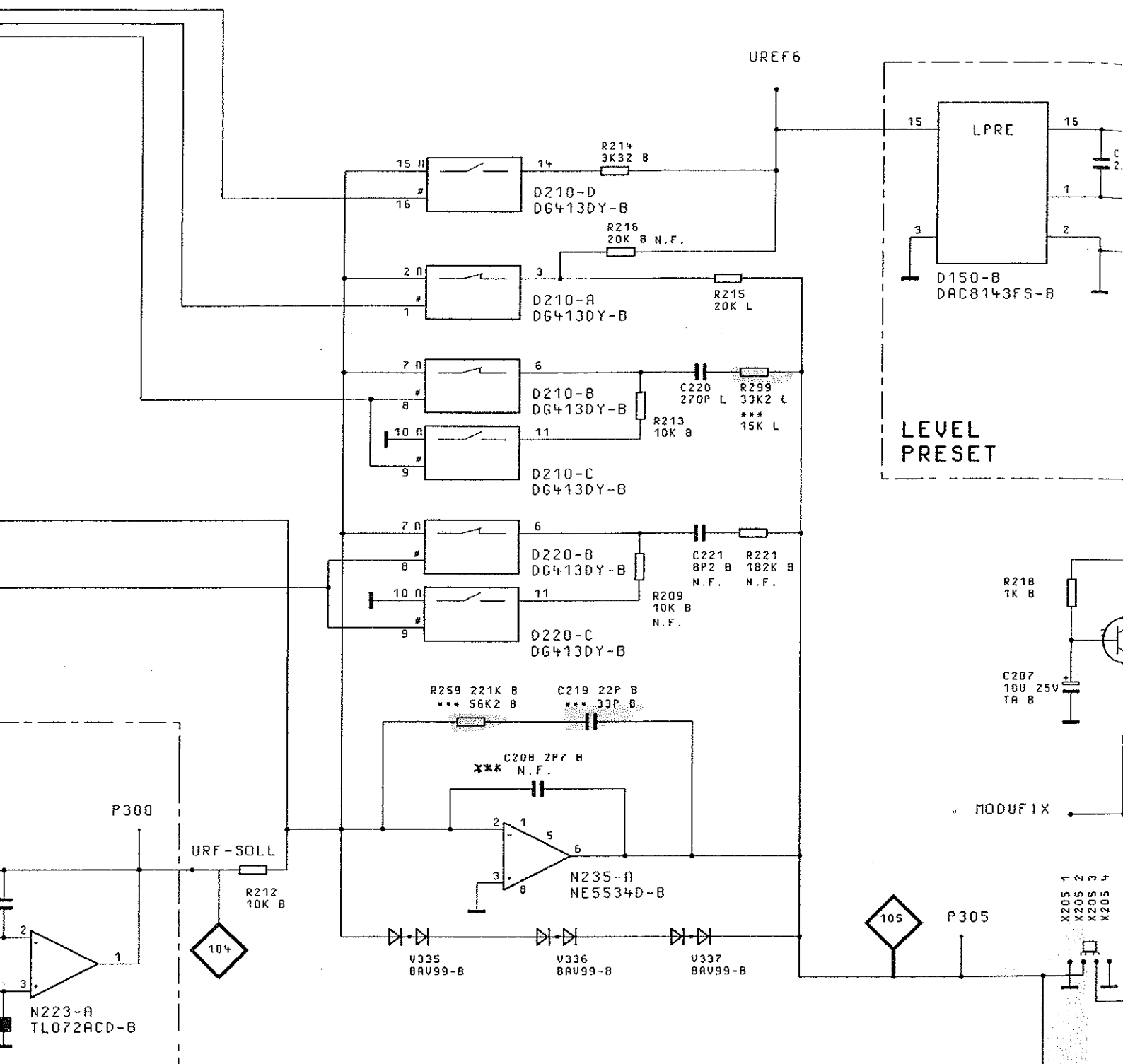

N.F. - NOT FITTED / NICHT BESTUECKT
 ** - VAR. 04 / MOD. 04
 *** - MIT/WITH OPTION SMY-B40

BINDENDE ANGABEN UEBER VARIANTEN,
 TRIMMWERTE, BAUTEILWERTE UND
 NICHT BESTUECKTE BAUTEILE SIEHE SA.

FOR BINDING
 TRIMMING AND
 NONFITTED CO



04/02		03.03.97	E I	MENP	TAG	
				BEARB.		
				GEPR.		
				NORM		
				PLOTT	03.03.97	
04/01		16.12.96	E I			
REND. IND.	ÄNDERUNGS- MITTEILUNG	DATUM	NAME	ROHDE & SCHWAB ZU GERÄT SMY		

P385

P285

P300

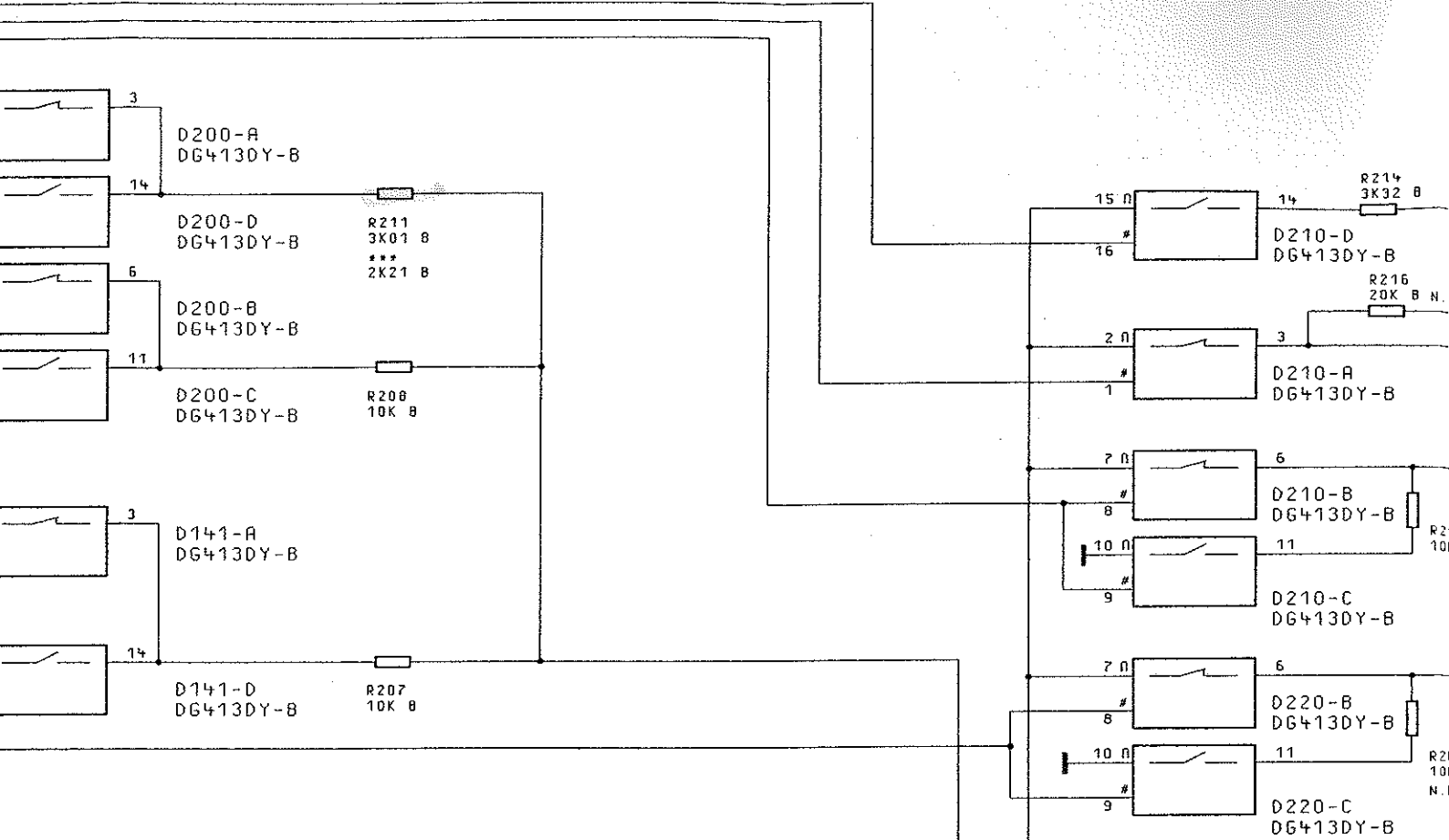

RF LEVEL

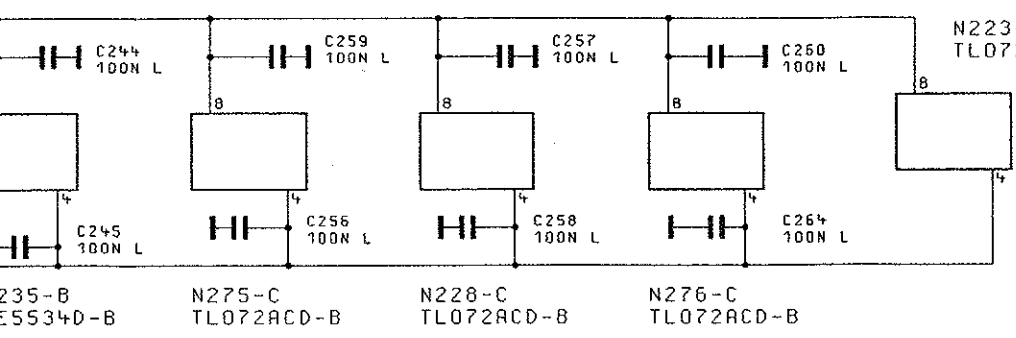
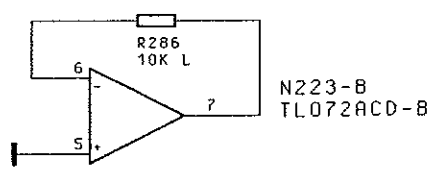
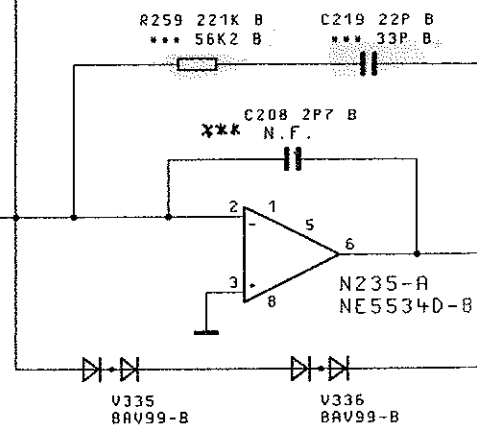
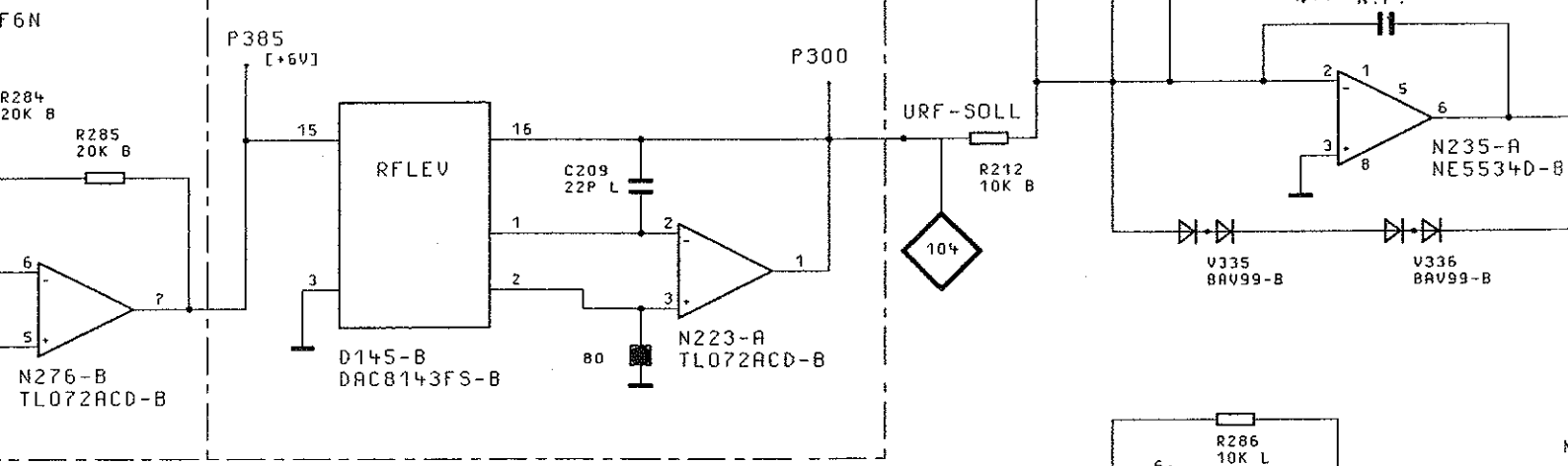



ACHTUNG: EGB!
ELEKTROSTATISCH GEFÄHRDETE
BAUELEMENTE ERFORDERN EINE
BESONDERE HANDhabUNG.
ATTENTION ESD!
ELECTROSTATIC SENSITIVE DEVICES
REQUIRE A SPECIAL HANDLING

5

6

7

8

R280

P380

P385

P285

P300

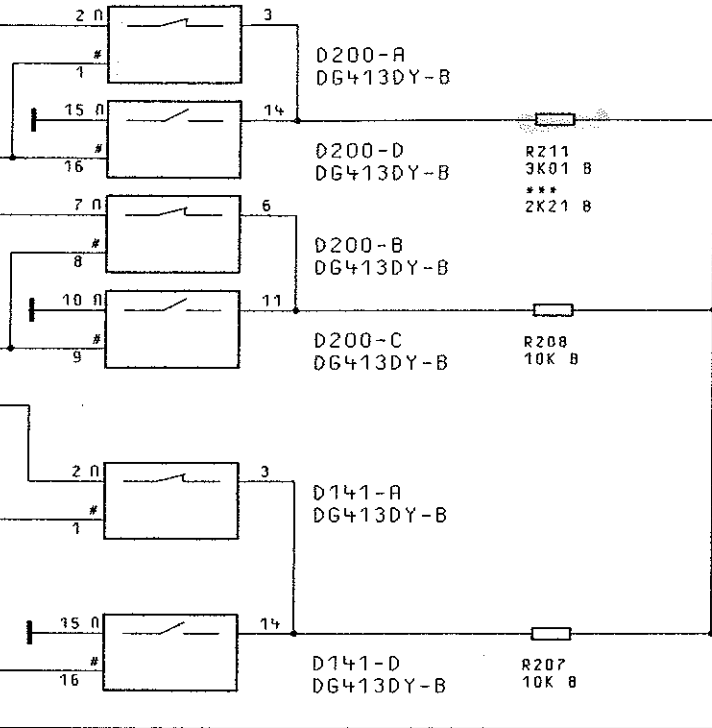

MODULATION DEPTH

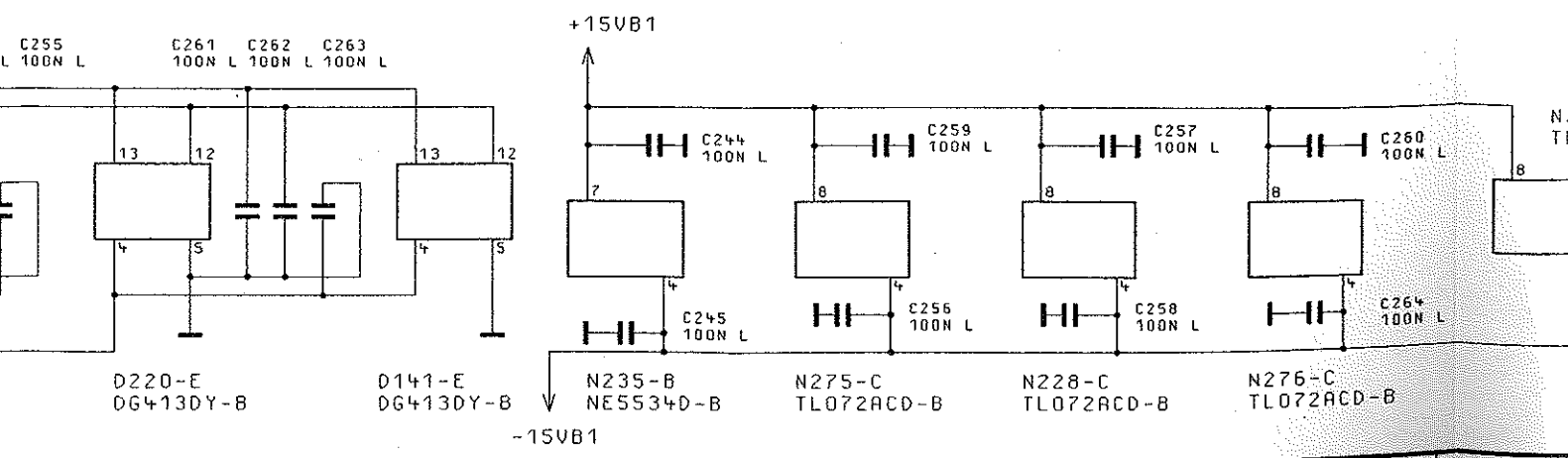
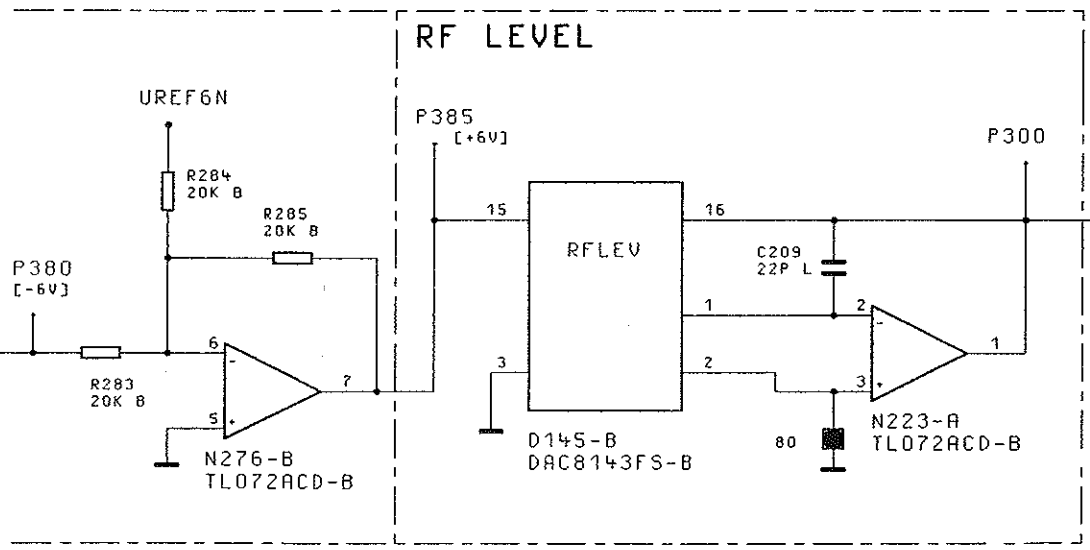
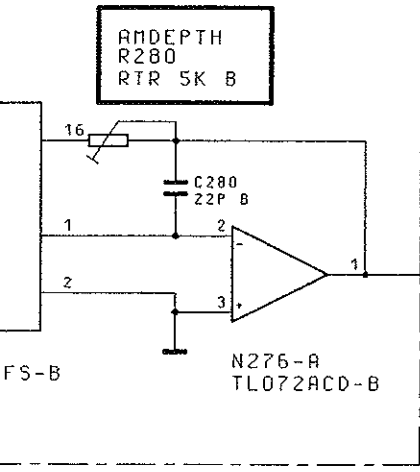
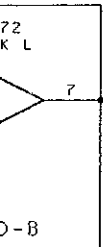

P375

R280

P380

P385

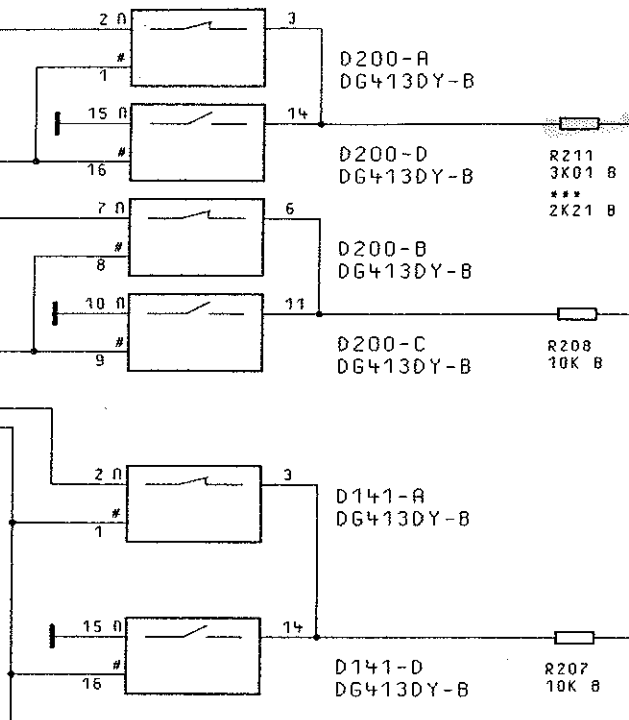

AMPLITUDE MODULATION DEPTH

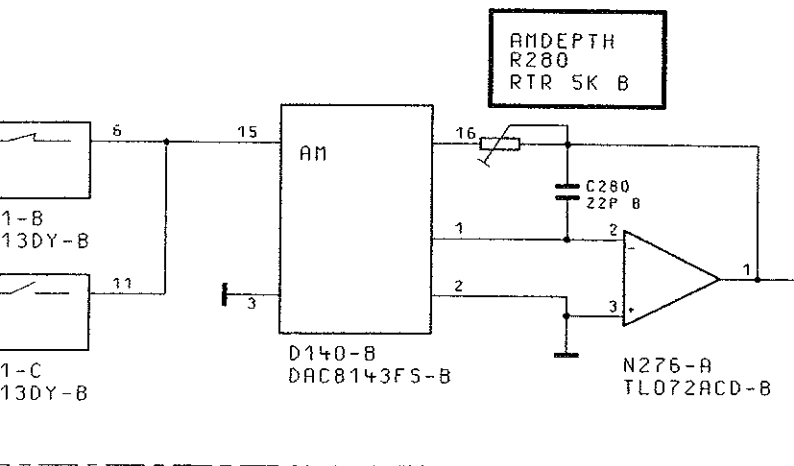
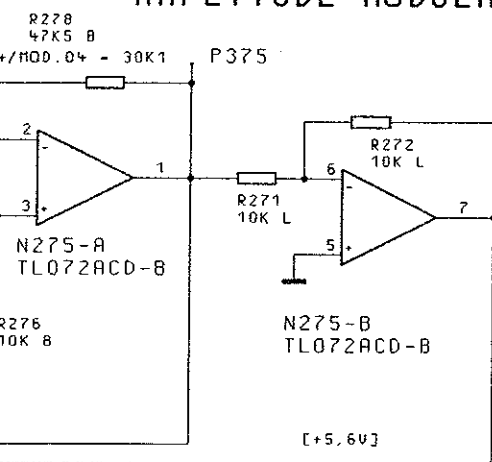

RF LEVEL

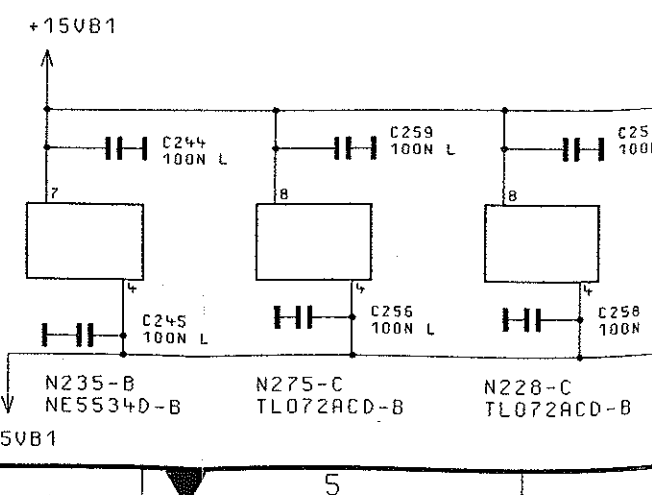
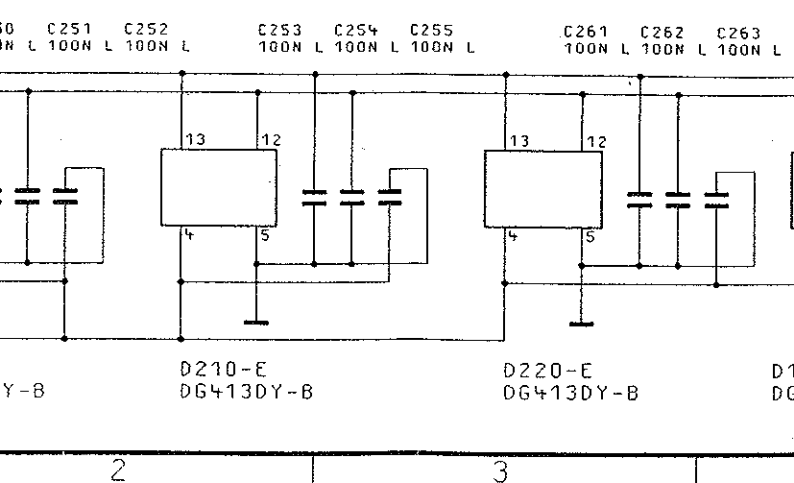
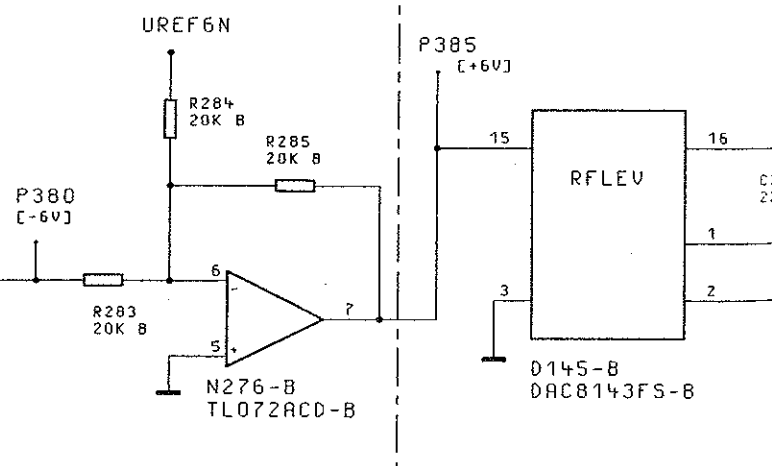

P375

R280

P380

KLEMM-N
ALCOFF
AMSLOW

VDETMIX

DETMIXON
(SHEET 1/E8)

VDET

DETON
(SHEET 1/E8)

VDEXT
VDEXTON

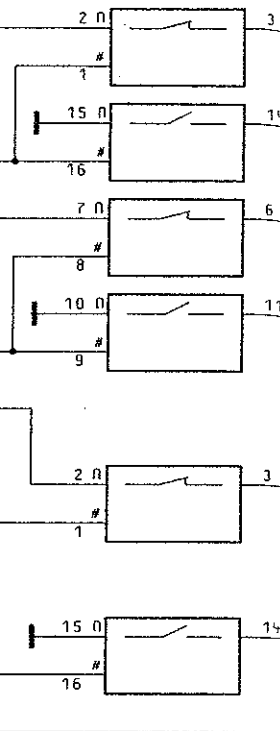

AMPLITUDE MODULATION DEPTH

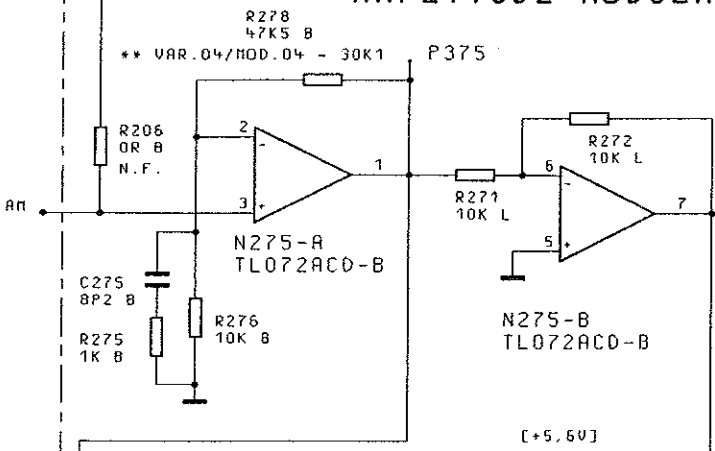

AMDEPTH
R280
RTR 5K B

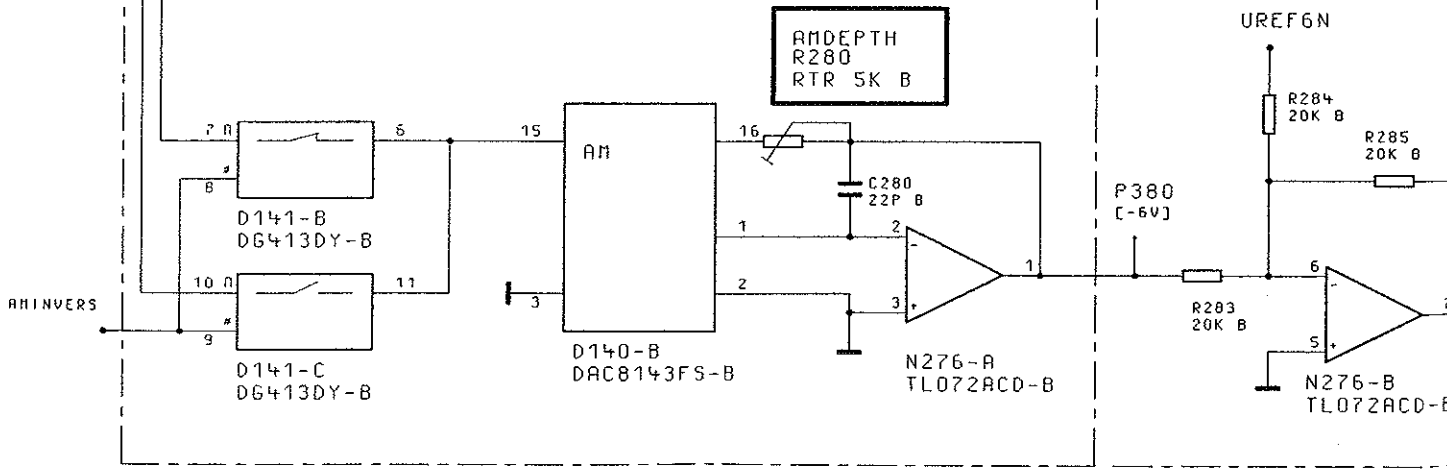

FUER DIESE UNTERLAGE
BEHALTEN WIR UNS ALLE RECHTE VOR

+15VB1 +5VB

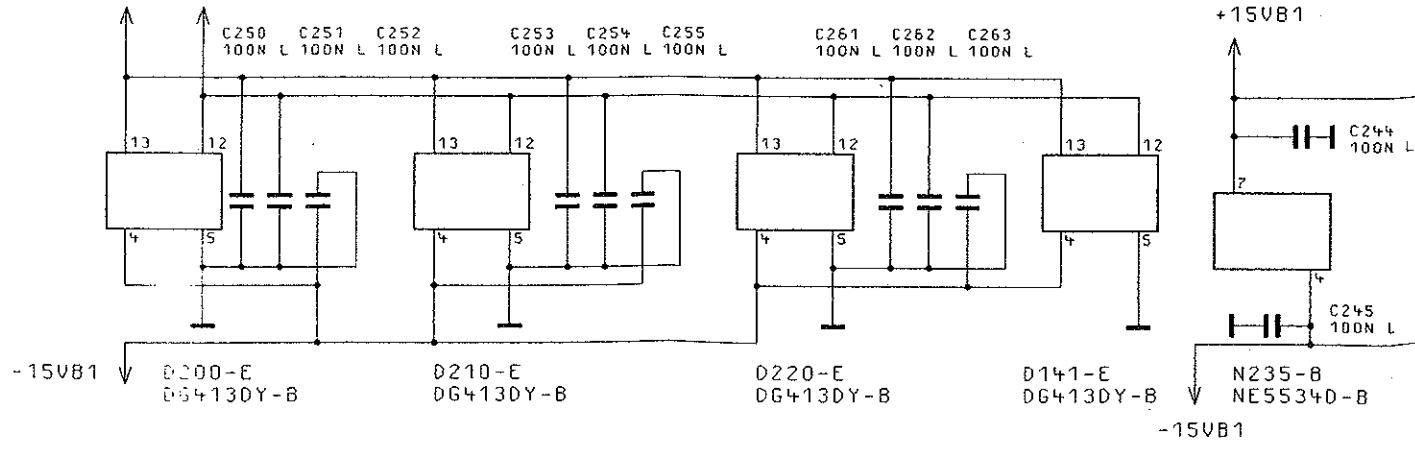

ZEICHN.-NR.

1 2 3 4

RF AMPLIFIER 1

RF AMPLIFIER 2

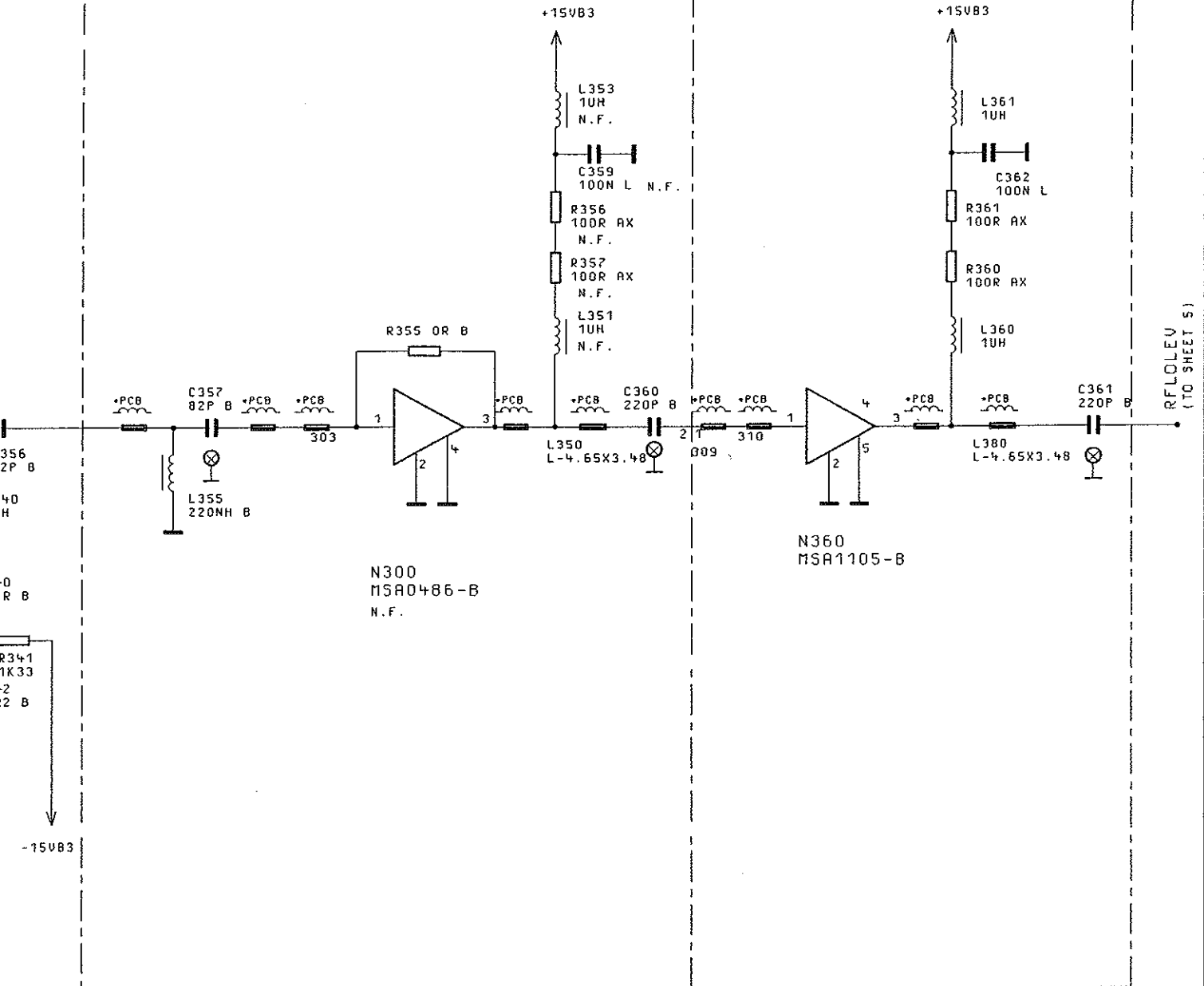

BINDENDE ANGABEN UEBER VARIANTEN,
TRIMMWERTE, BAUTEILWERTE UND
NICHT BESTUECKTE BAUTEILE SIEHE SA.

FOR BINDING INFORMATION ON MODELS,
TRIMMING AND COMPONENTS VALUES AND
NONFITTED COMPONENTS SEE PARTS LIST.

04/02		03.03.97	E I	MENP	TAG	NARE	BENENNUNG		
				BEARB.		E I	AUSGANGSTEIL 2.08GHZ OUTPUT UNIT 2.08GHZ		
				GEPR.					
				NORM					
				PLOTT	03.03.97				
04/01		16.12.96	E I	ROHDE&SCHWARZ			ZEICHN.-NR.	BLATT-NR.	
REND. IND.	RENDERUNGS- MITTEILUNG	DATUM	NARE				1062.7005.015	4+	
				ZU GERAT	SMY	REG.I.V.	1062.5502	ERSTE Z.	1062.5502

RF AMPLIFIER 1

RF 1

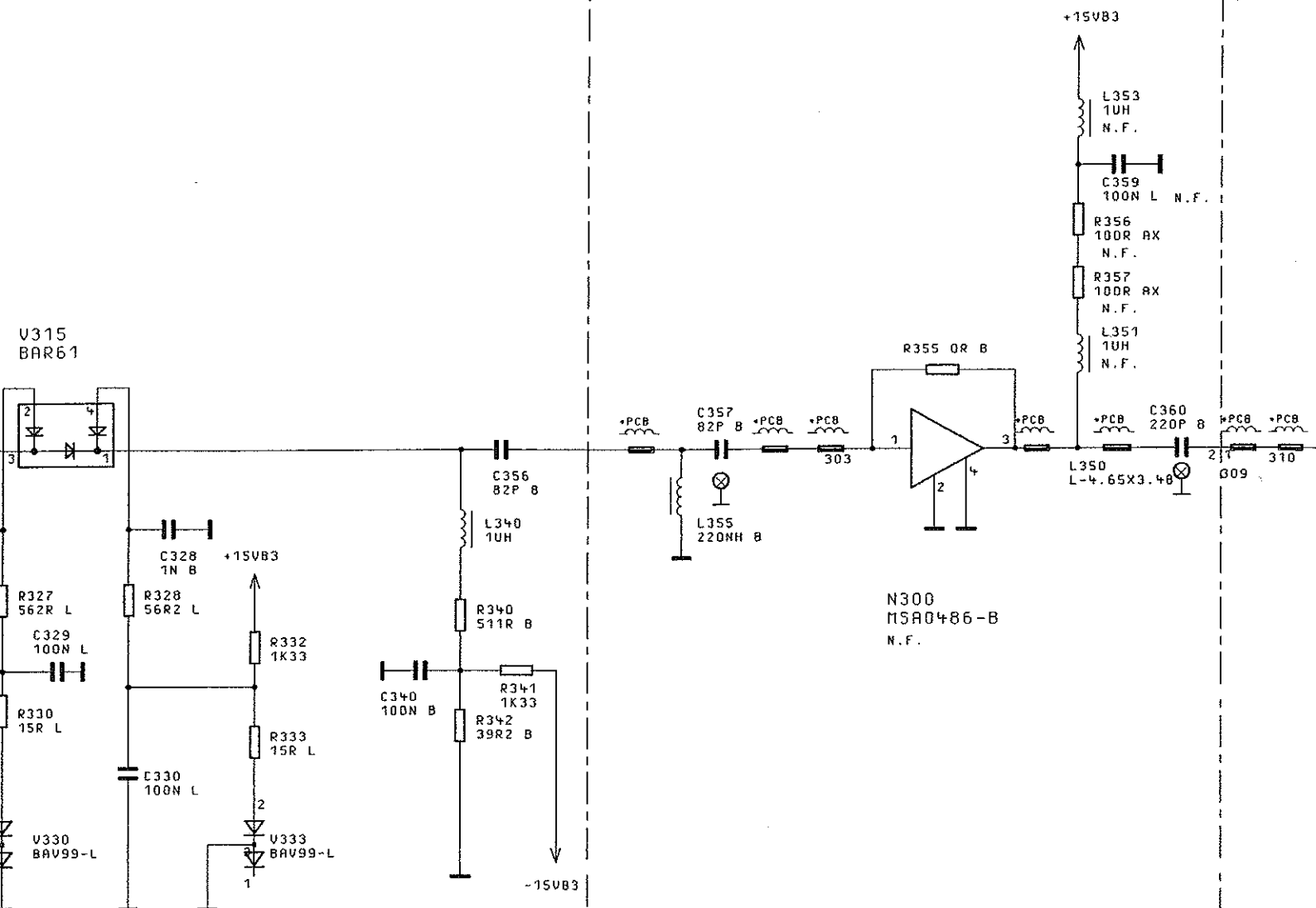

N.F. - NOT FITTED / NICHT BESTUECKT

BINDENDE ANGABEN UEBER VARIANTEN, TRIMMWERTE, BAUTEILWERTE UND NICHT BESTUECKTE BAUTEILE SIEHE SA.

FOR BINDING INFORMATION ON MODELS, TRIMMING AND COMPONENTS VALUES AND NONFITTED COMPONENTS SEE PARTS LIST

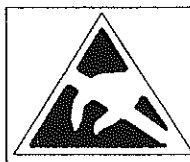

ACHTUNG: EGB!
 ELEKTROSTATISCH GEFAEHRDETE
 BAUELEMENTE ERFORDERN EINE
 BESONDERE HANDHABUNG.
ATTENTION ESD!
 ELECTROSTATIC SENSITIVE DEVICES
 REQUIRE A SPECIAL HANDLING

04/02	03.03.97	EI	MENP	TAG	NAME	BENENNUNG
			BEARB.		EI	AUS OUTPUT
			GEPR.			
			NORM			
			PLOTT	03.03.97		
04/01	16.12.96	EI				ZEICHN.-NR.
REND. IND.	ÄNDERUNGS- MITTEILUNG	DATUM	NAME	ROHDE&SCHWARZ		REG. I. V. 1
				ZU GERÄT	SMY	

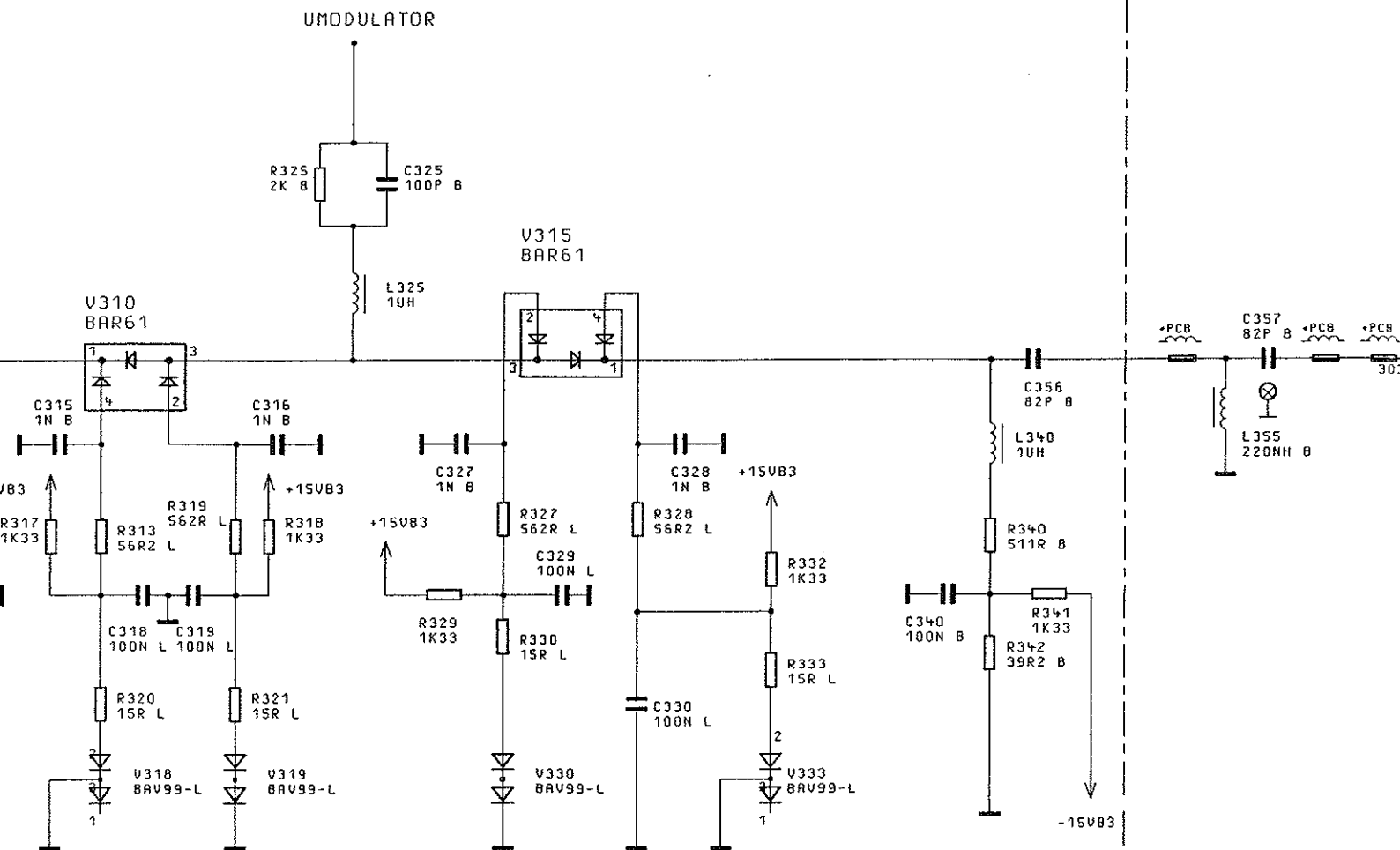

N.F. - NOT FITTED / NICHT BESTUECKT

BINDENDE ANGABEN UEBER VARIABILE TRIMMWERTE, BAUTEILWERTE UND NICHT BESTUECKTE BAUTEILE SIND

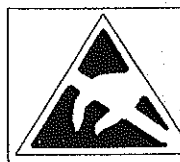

ACHTUNG: ESD!
ELEKTROSTATISCH GEFAHRDETE BAUELEMENTE ERFORDERN EINE BESONDERE HANDHABUNG.
ATTENTION ESD!
ELECTROSTATIC SENSITIVE DEVICES REQUIRE A SPECIAL HANDLING

04/02		03.03
04/01		16.12
REND.	RENDERUNGS- MITTEILUNG	DATU

AM MODULATOR

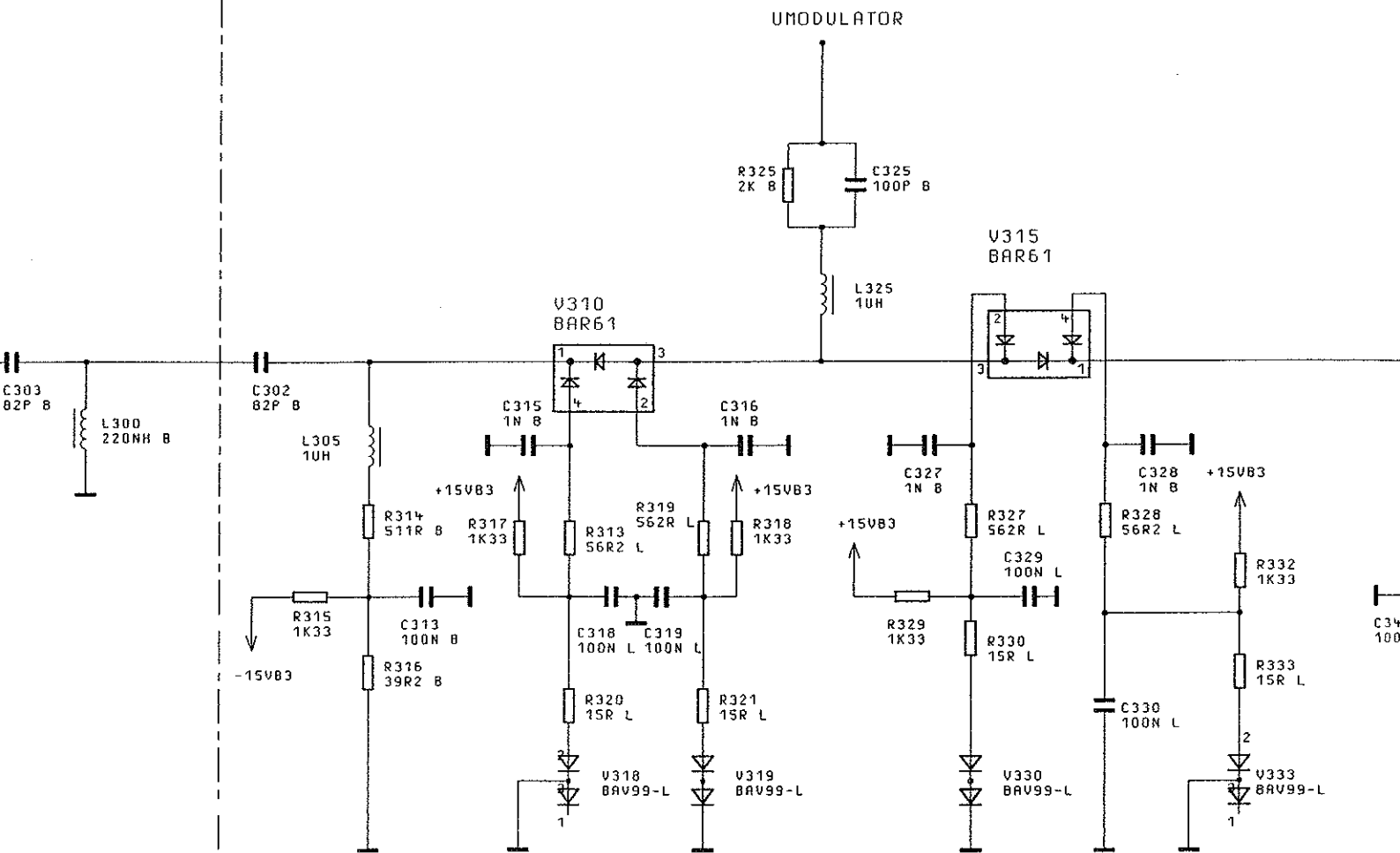

N.F. - NOT FITTED / NICHT BEST

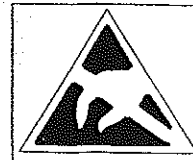

ACHTUNG: EGB
ELEKTROSTATISCH GEFÄHR
BAUELEMENTE ERFORDERN
BESONDERE HANDHABUNG
ATTENTION ESD
ELECTROSTATIC SENSITIVE
REQUIRE A SPECIAL HANDLING

SENSATION

AM MODULATOR

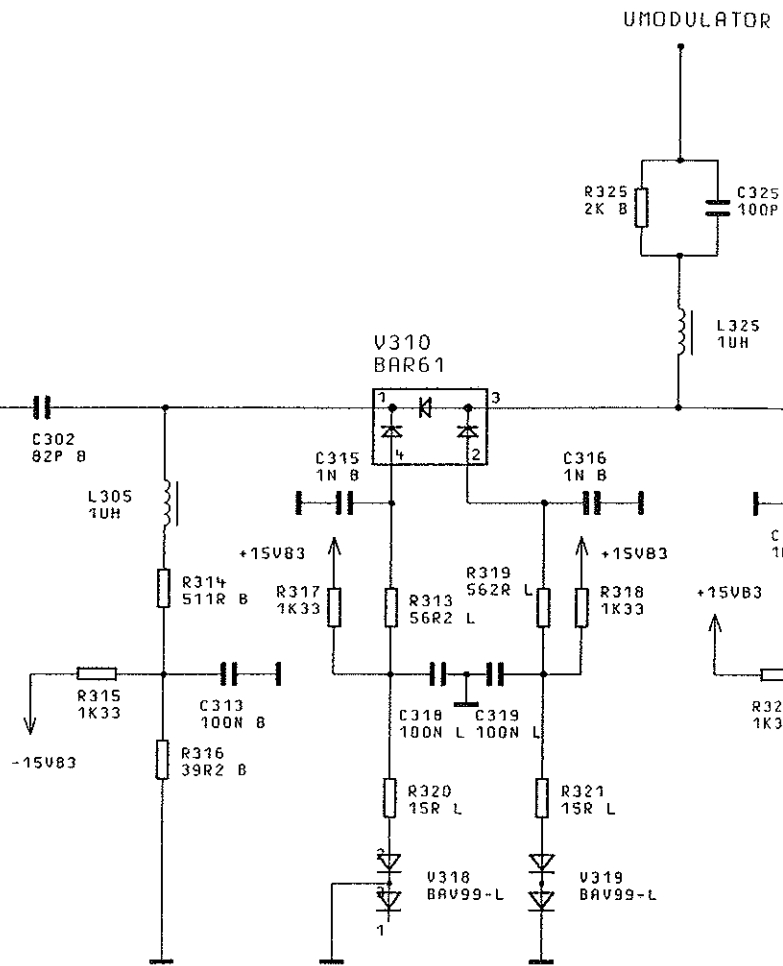
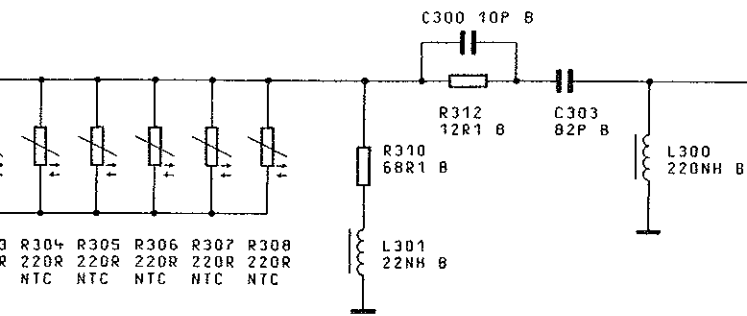

UMODULATOR

TEMP.-KOMPENSATION

AM MODU

X224 1

FSYN
6...1208M
65...1040MHZ

R300	R301	R302	R303	R304	R305	R306	R307	R308
22R B	220R	220R	220R	220R	220R	220R	220R	220R
6HZ	NTC	NTC	NTC	NTC	NTC	NTC	NTC	NTC

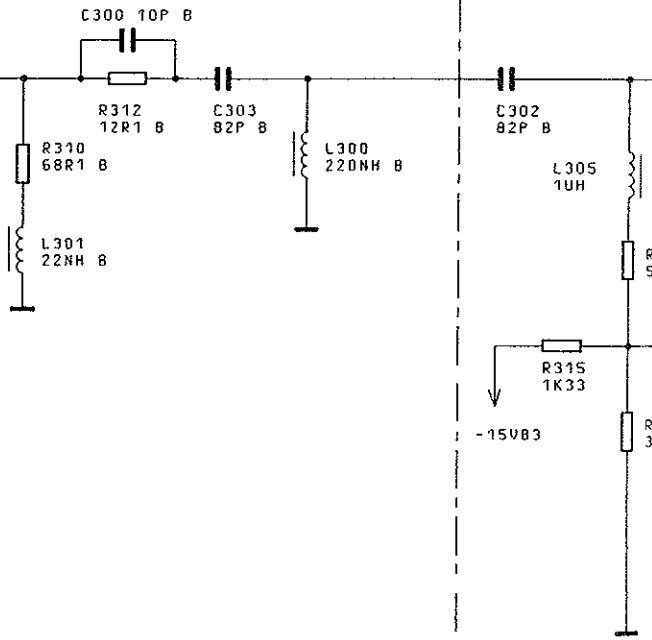

BEHALTEN WIR UNS ALLE RECHTE VOR
FÜR DIESE ÜBERLAGE

LP SELECT

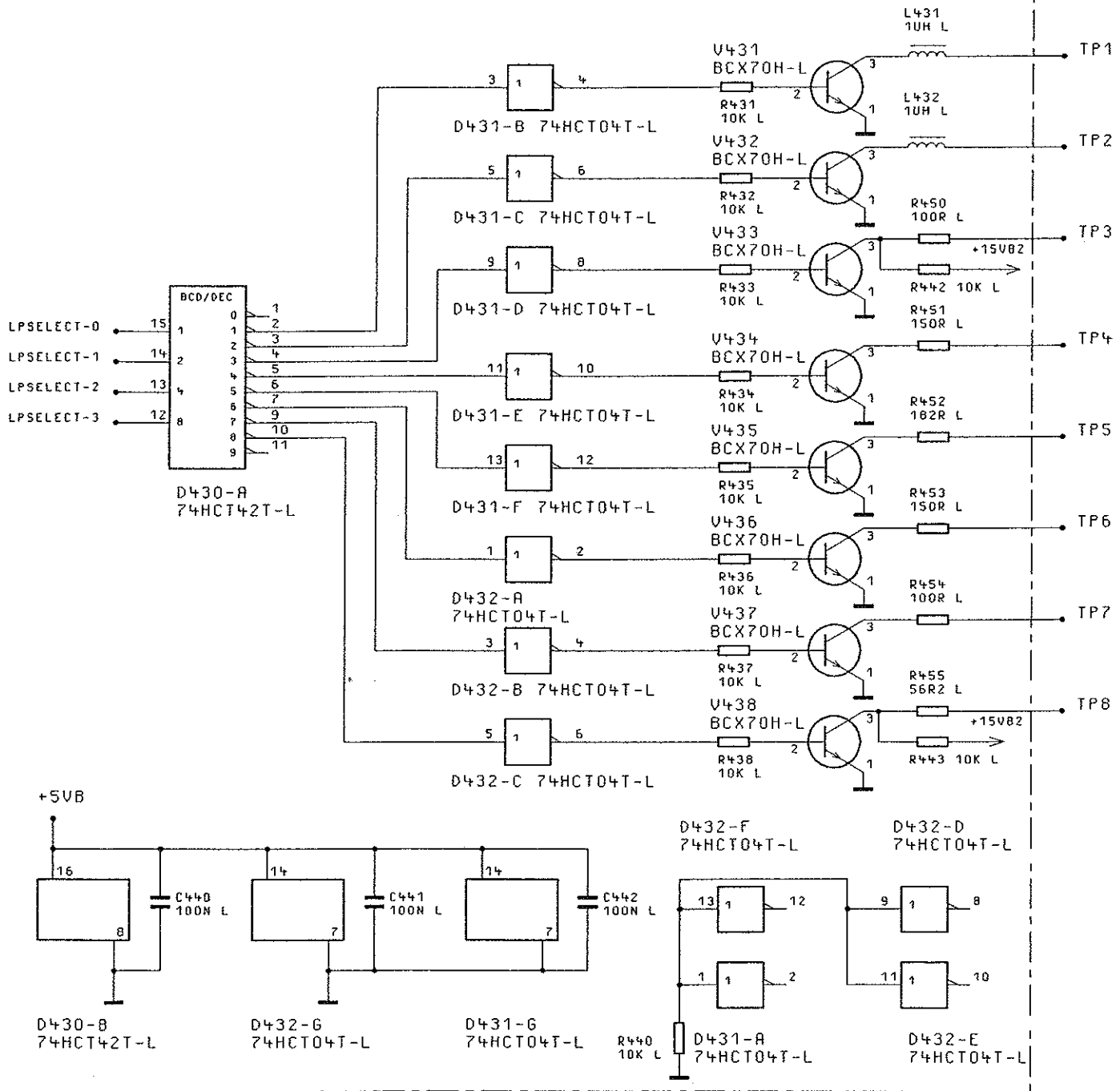

BINDEnde ANgABEN UEBER VARIANTEN,
TRIMMWERTE, BAUTEILWERTE UND
NICHT BESTUECKTE BAUTEILE SIEHE SA.

FOR BINDING INFORMATION ON MODELS,
TRIMMING AND COMPONENTS VALUES AND
NONFITTED COMPONENTS SEE PARTS LIST.

04/02		03.03.97		EI	MENP	TAG	NAME	BENENNUNG		
					BEARB.		EI	AUSGANGSTEIL 2.08GHZ OUTPUT UNIT 2.08GHZ		
					GEPR.					
					NORM					
					PLOTT	03.03.97				
04/01		16.12.96		EI	ROHDE & SCHWARZ			ZEICHN.-NR.		
REND. IND.		ÄNDERUNGS-MITTEILUNG		DATUM				NAME		1062.7005.01S
					ZU GERÄT		SMY		REG.-I.V.	
									1062.5502	
									ERSTE Z.	
									1062.5502	
									BLATT-NR.	
									5+	
									V. BL.	

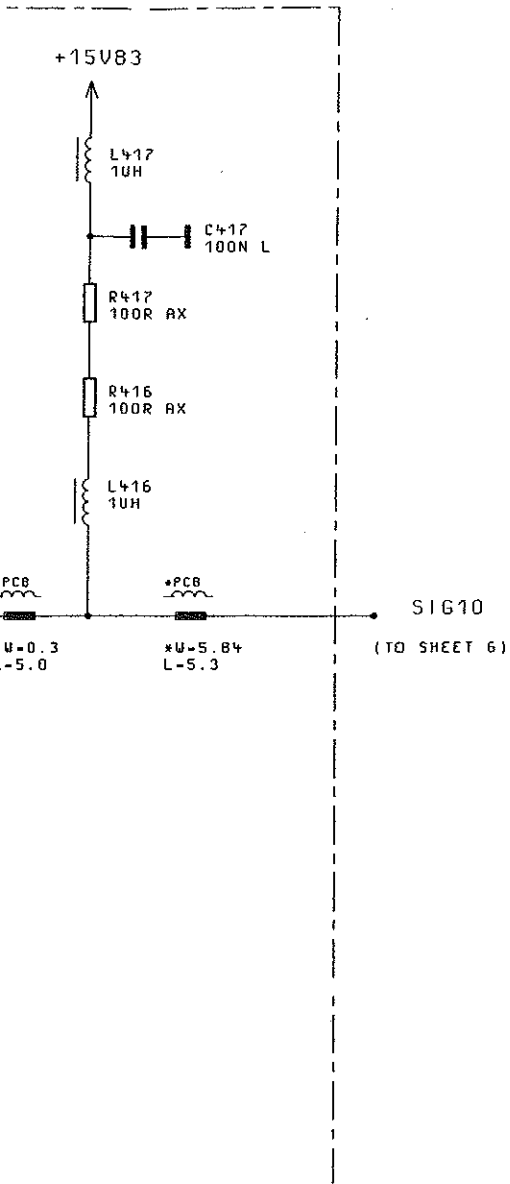

LP SELECT

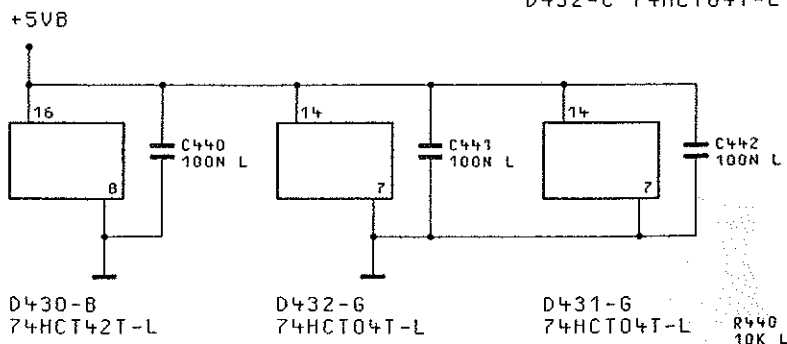
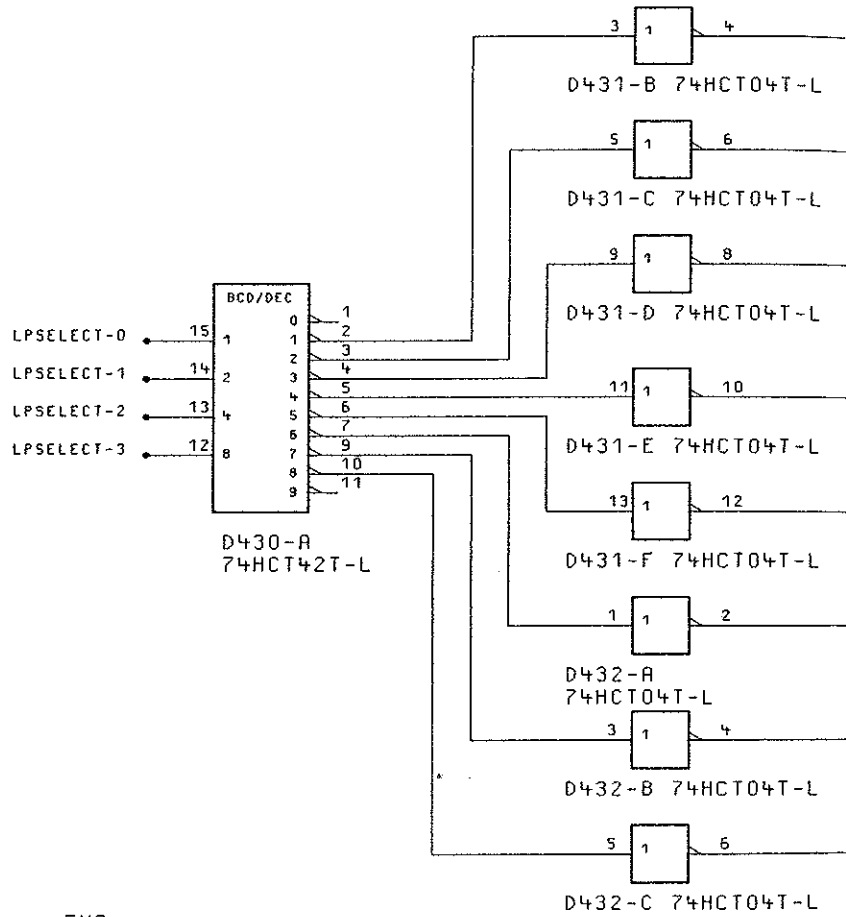

BINDENDE ANGABEN UEBER VARIANTEN,
TRIMMWERTE, BAUTEILWERTE UND
NICHT BESTUECKTE BAUTEILE SIEHE SA.

FOR BINDING INFORMATION
TRIMMING AND COMPONENT
NONFITTED COMPONENTS SEE SA.

N.F. - NOT FITTED / NICHT BESTUECKT

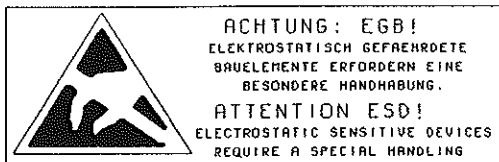

04/02		03.03.97	E I	MENP	TAG	NAME
				BEARB.		E I
				GEPR.		
				NORM		
				PLOTT	03.03.97	
04/01		16.12.96	E I			
ÄND. IND.	ÄNDERUNGS-MITTEILUNG	DATUM	NAME			
				ROHDE & SCHWARZ ZU GERÄT SMY		

B3 RF AMPLIFIER 3

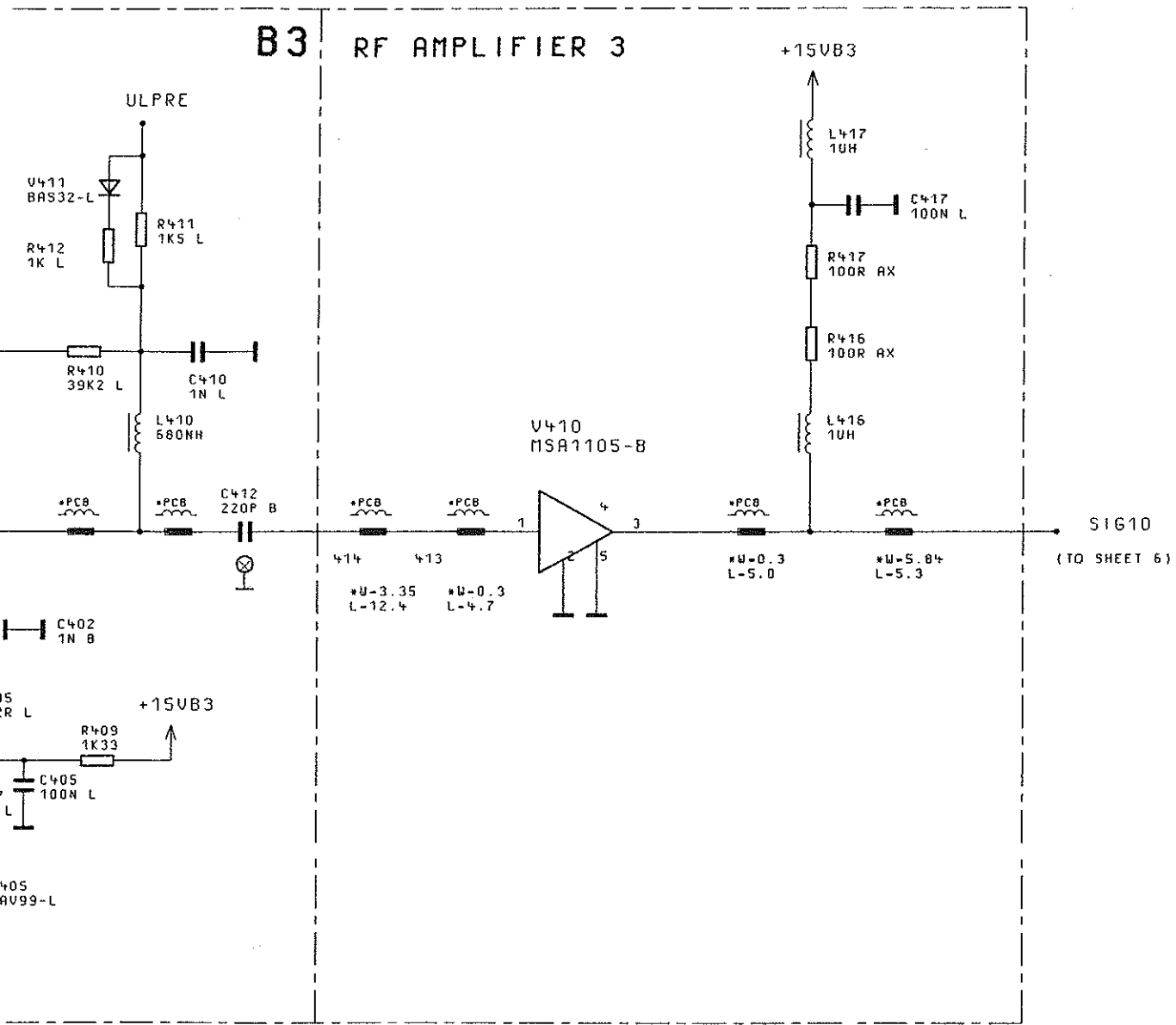

N.F. - NOT FITTED / NICHT BESTUECKT

ACHTUNG: EGB!
 ELEKTROSTATISCH GEFÄHRDETE
 BAUELEMENTE ERFORDBEN EINE
 BESONDERE HANDHABUNG.
ATTENTION ESD!
 ELECTROSTATIC SENSITIVE DEVICES
 REQUIRE A SPECIAL HANDLING

B3 RF AMPLIFIER 3

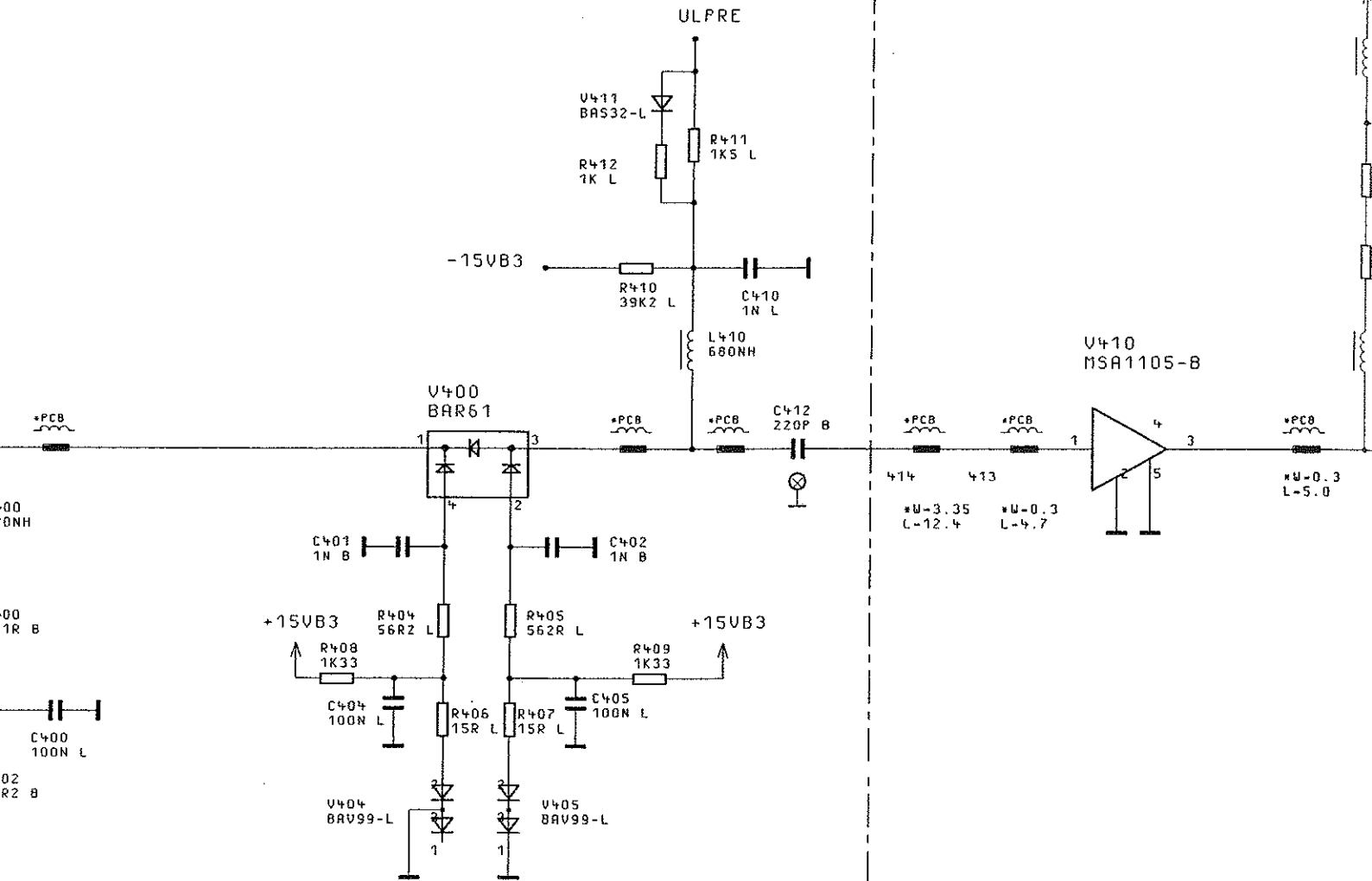

LEVEL PRESET

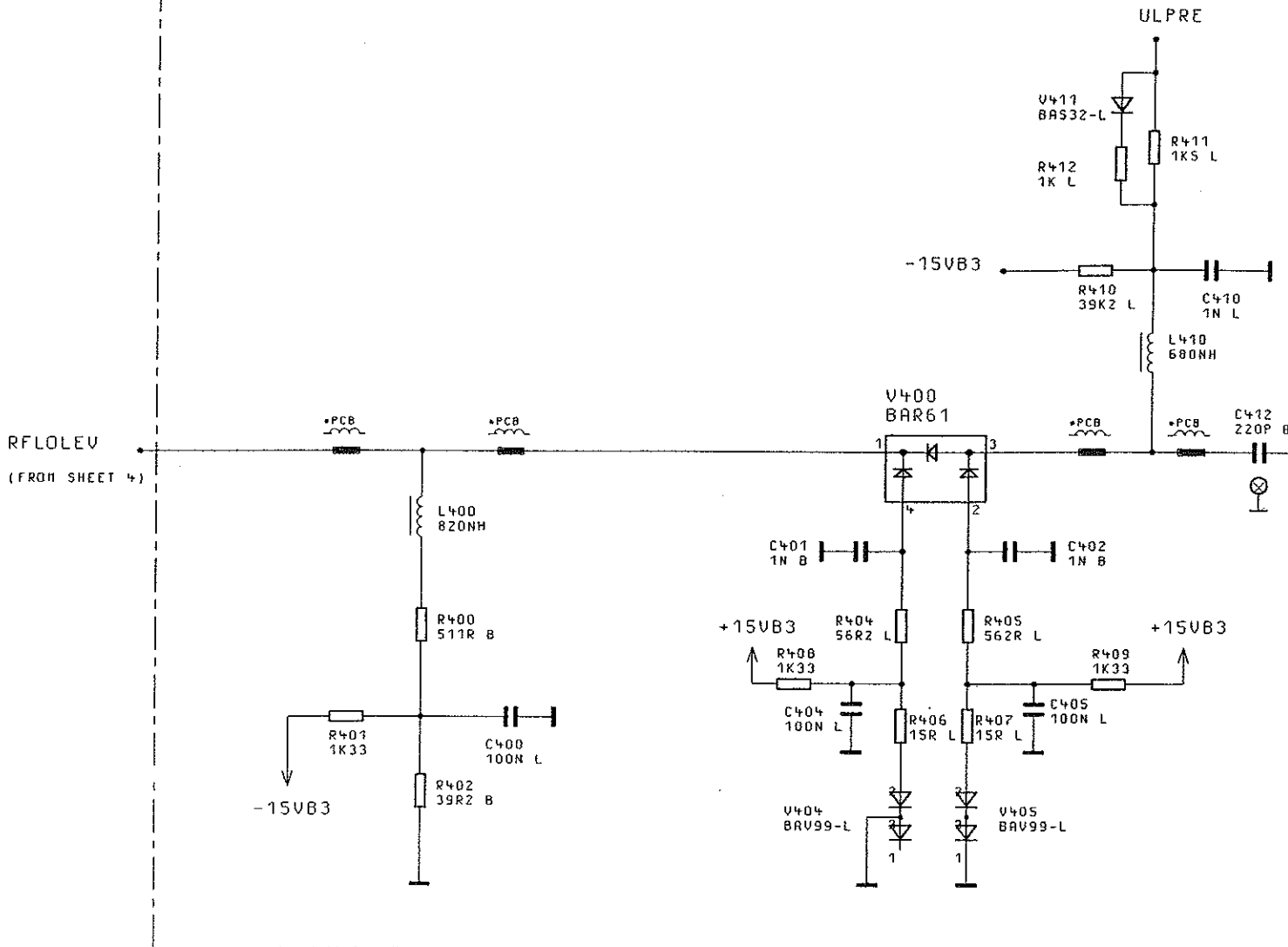

BEHALTEN WIR UNS ALLE RECHTE VOR

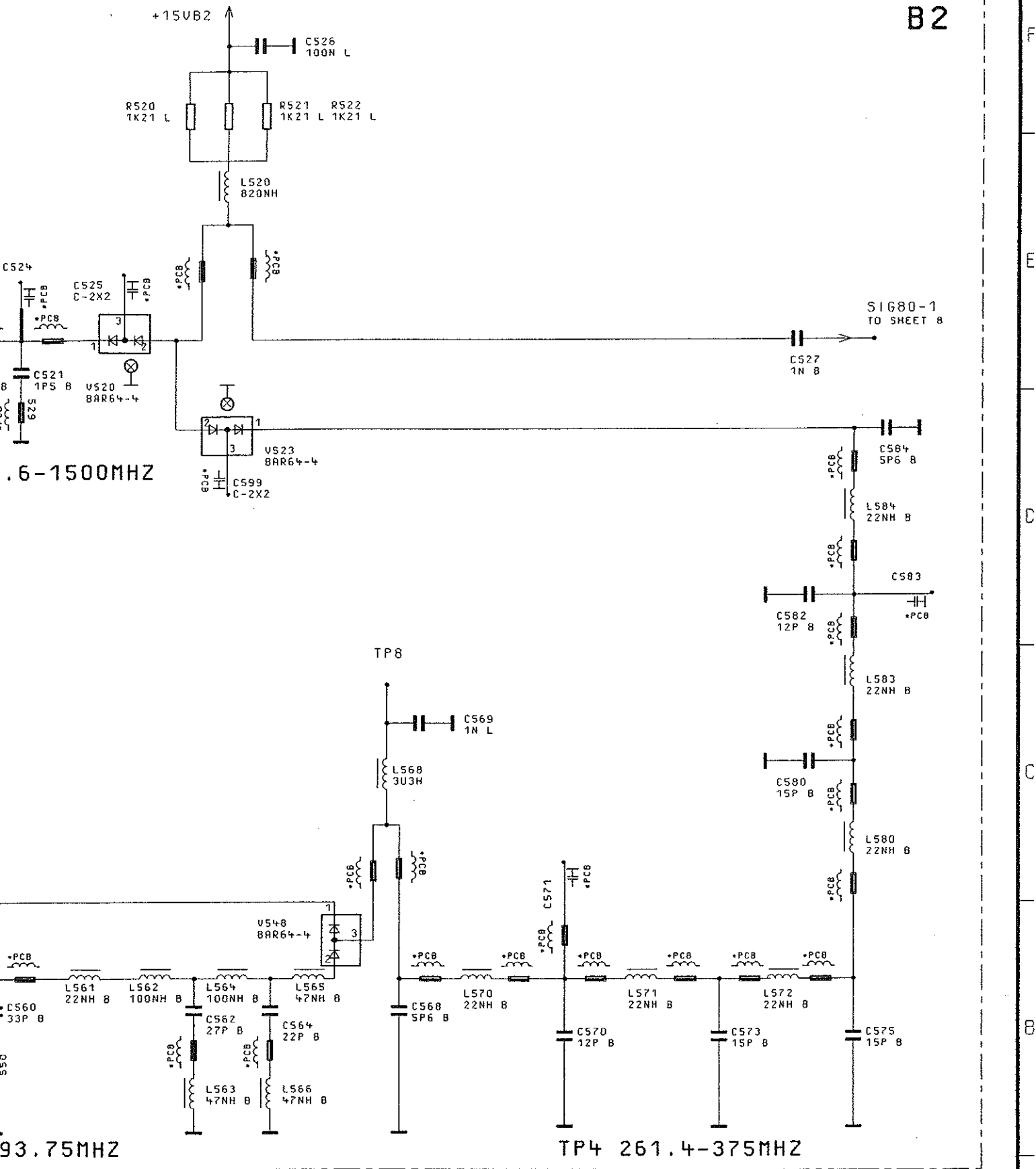

04/02		03.03.97	E I	MENP	TAG	NAME	BENENNUNG
				BEARB.		E I	AUSGANGSTEIL 2.086HZ OUTPUT UNIT 2.086HZ
				GEPR.			
				NORM			
				PLOTT	03.03.97		
04/01		16.12.96	E I	ROHDE & SCHWARZ			ZEICHN.-NR.
REND. IND.	ENDERUNGSMITTEILUNG	DATUM	NAME				1062.7005.019
				ZU GERÄT	SMY	REG. I. V.	1062.5502
						ERSTE Z.	1062.5502

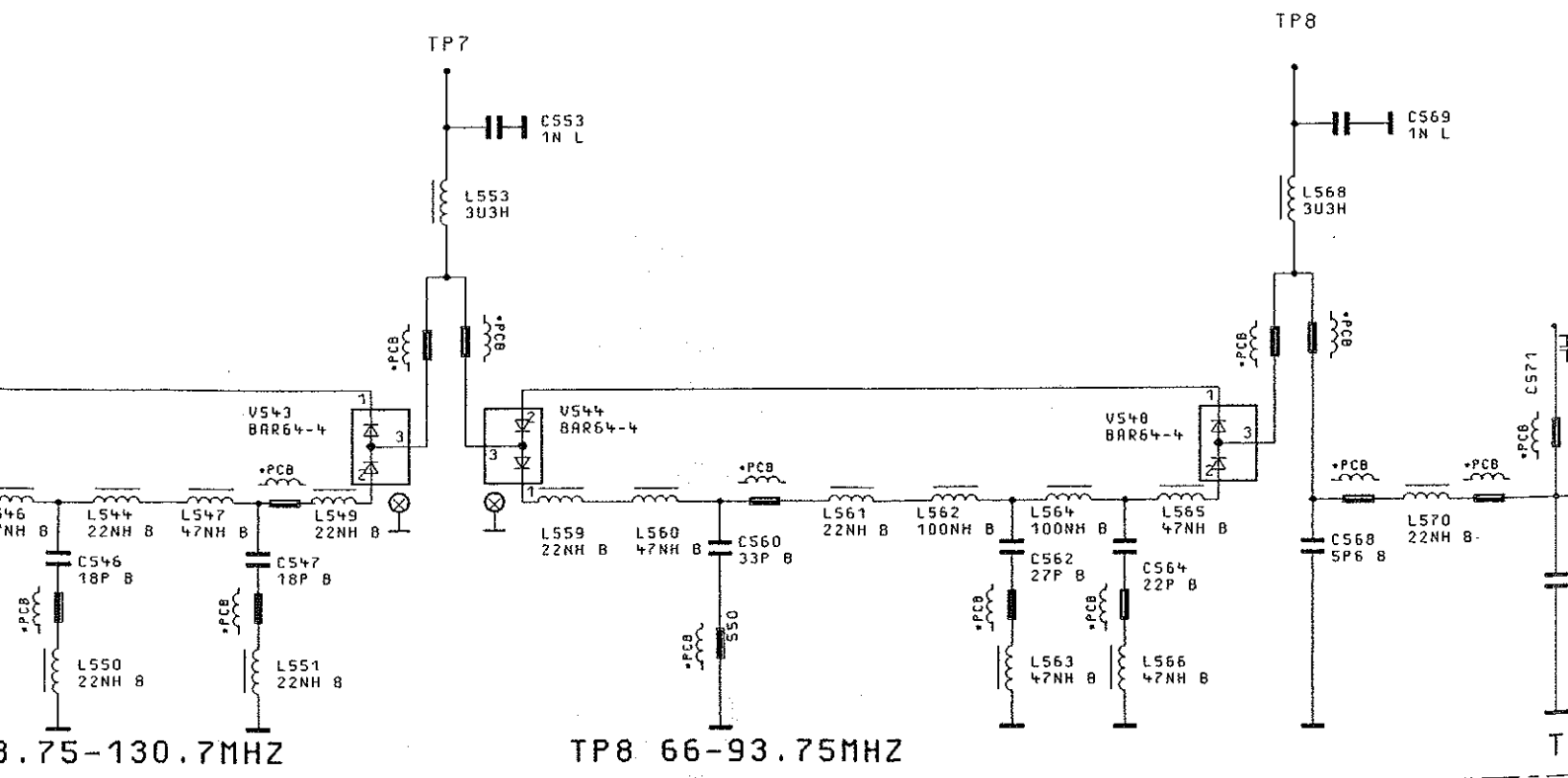
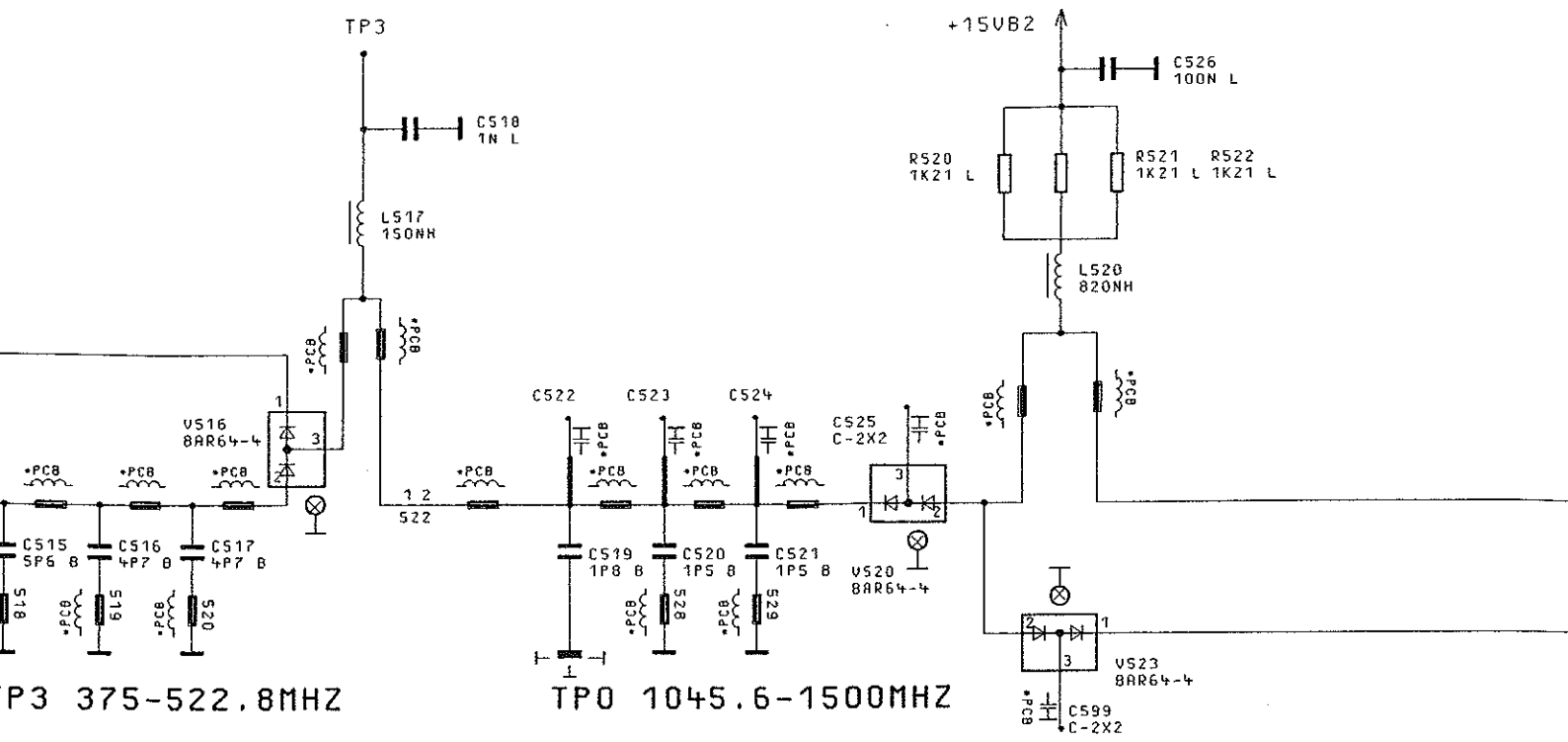

NICHT BESTUECKT

BINDENDE ANGABEN UEBER VARIANTEN,
TP WERTE, BAUTEILWERTE UND
NICHT BESTUECKTE BAUTEILE SIEHE SA.

FOR BINDING INFORMATION ON MODELS,
TRIMMING AND COMPONENTS VALUES AND
NONFITTED COMPONENTS SEE PARTS LIST.

WICHTUNG: EGB!
STATISCH GEFAHRDETE
ELEMENTE ERFORDERN EINE
SONDERE HANDHABUNG.
ATTENTION ESD!
STATIC SENSITIVE DEVICES
REQUIRE A SPECIAL HANDLING

04/02		03.03.97	E I	MENP	TAG	NAME
				BEARB.		E I
				GEPR.		
				NORM		
				PLOTT	03.03.97	
04/01		16.12.96	E I			
REND. IND.	RENDERUNGS- MITTEILUNG	DATUM	NAME			
				ZU SERNET	SMY	

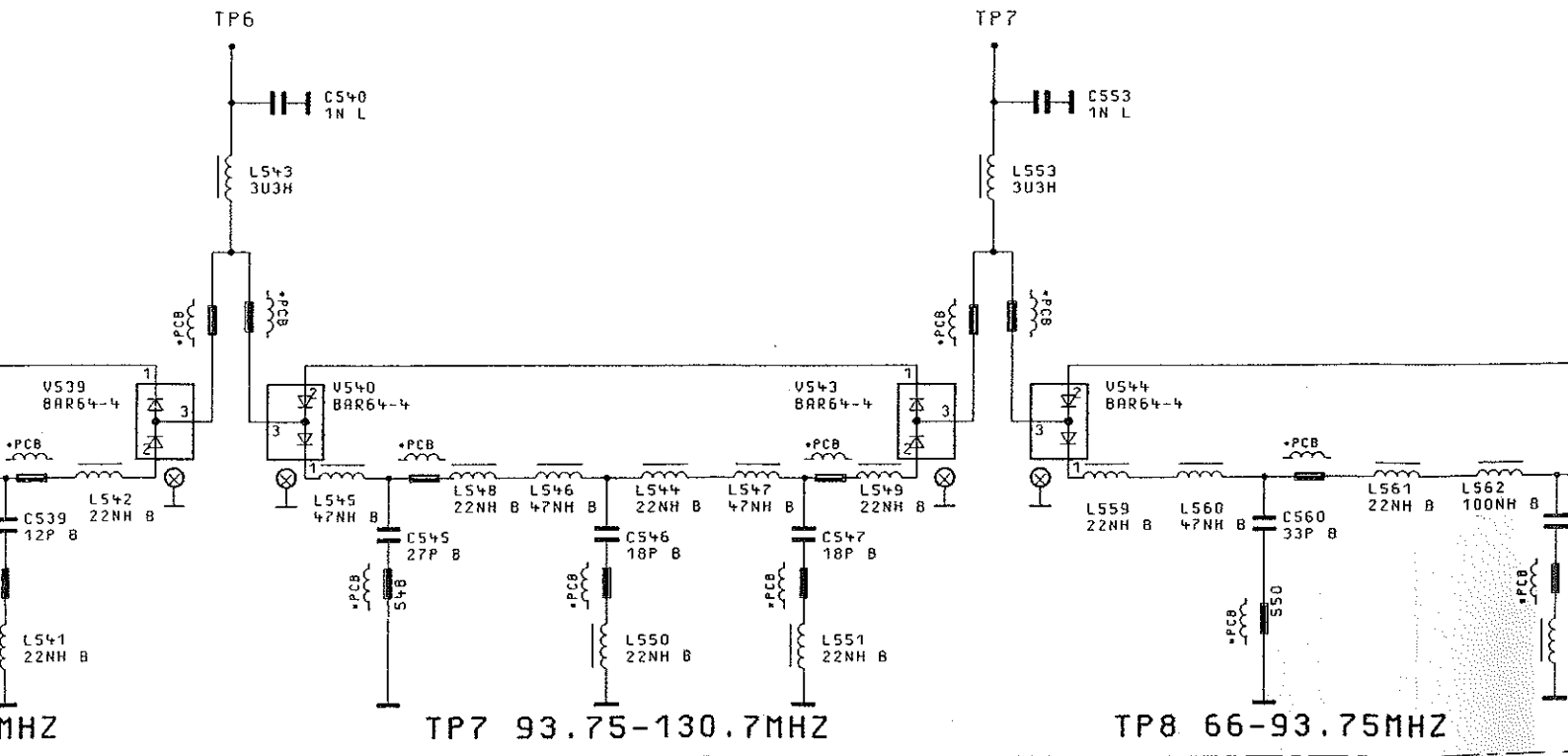
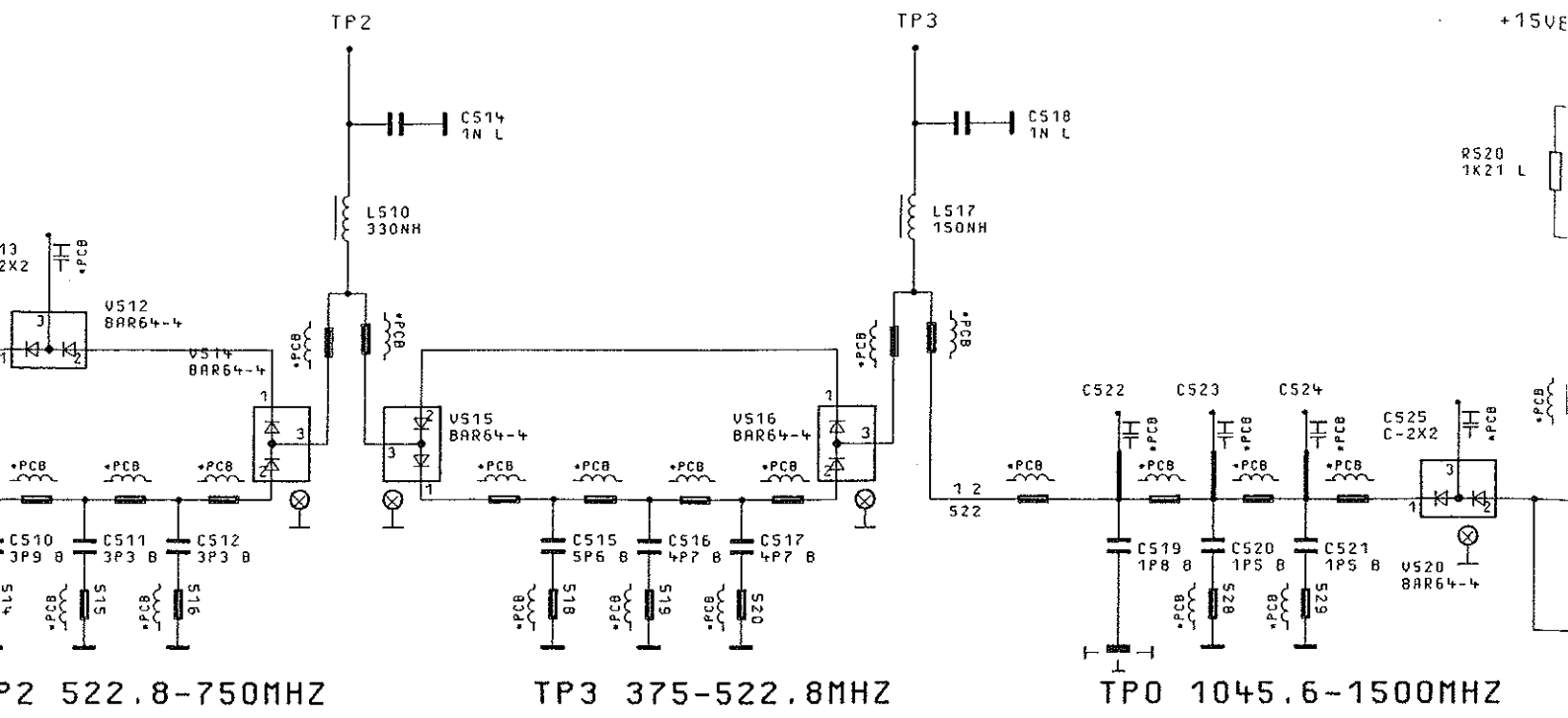

N.F. - NOT FITTED / NICHT BESTUECKT

BINDENDE ANGABEN UEBER VARIANTEN,
TRIMMWERTE, BAUTEILWERTE UND
NICHT BESTUECKTE BAUTEILE SIEHE SA.

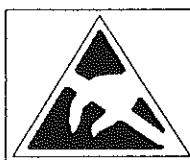

ACHTUNG: EGB!
ELEKTROSTATISCH GEFÄHRDETE
BAUELEMENTE ERFORDERN EINE
BESONDERE HANDHABUNG.
ATTENTION ESD!
ELECTROSTATIC SENSITIVE DEVICES
REQUIRE A SPECIAL HANDLING

FOR BINDING INFORMATION ON MODELS,
TRIMMING AND COMPONENTS VALUES AND
NONFITTED COMPONENTS SEE PARTS LIST.

04/02	
04/01	
REND.	ÄNDERUNG
IND.	NITTEILUNG

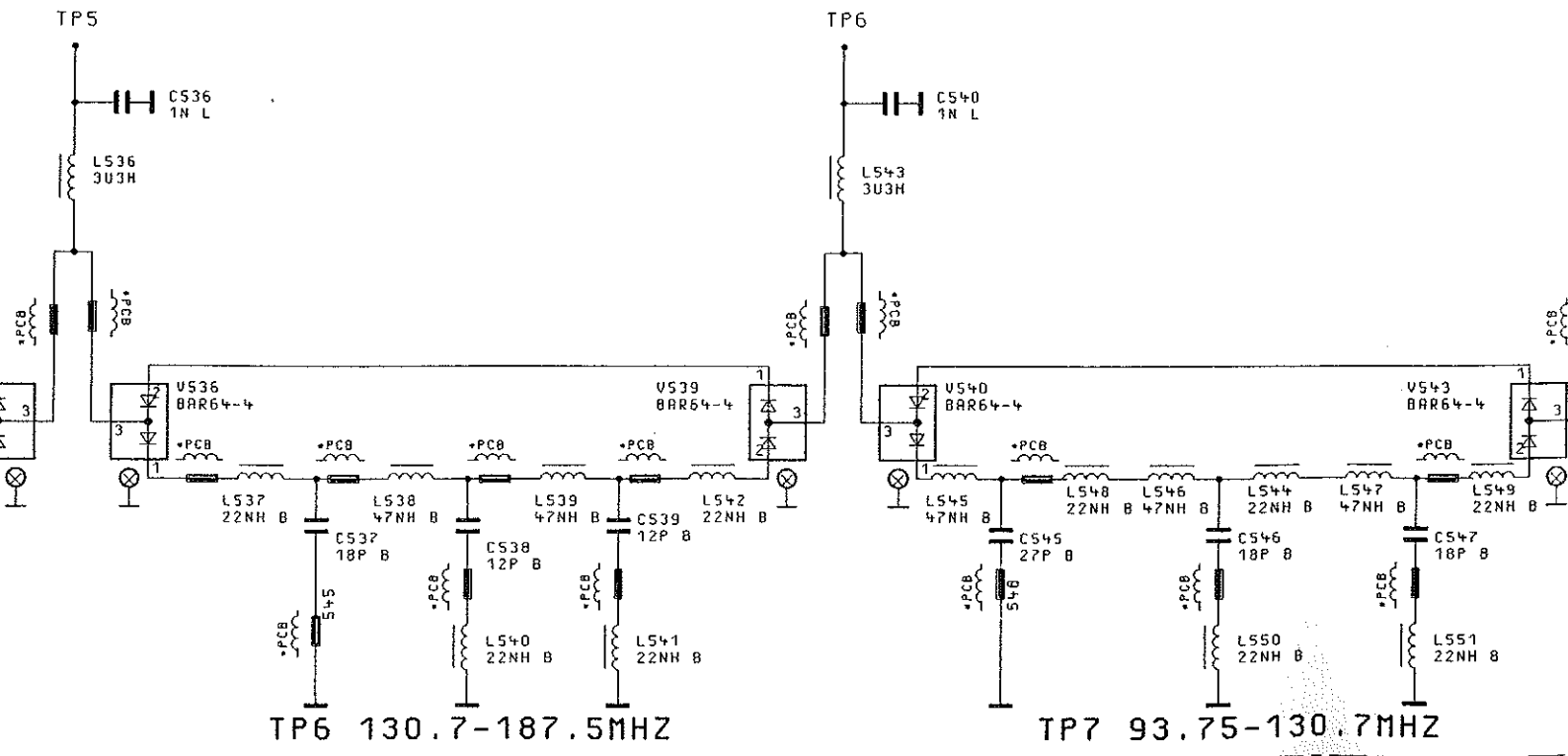
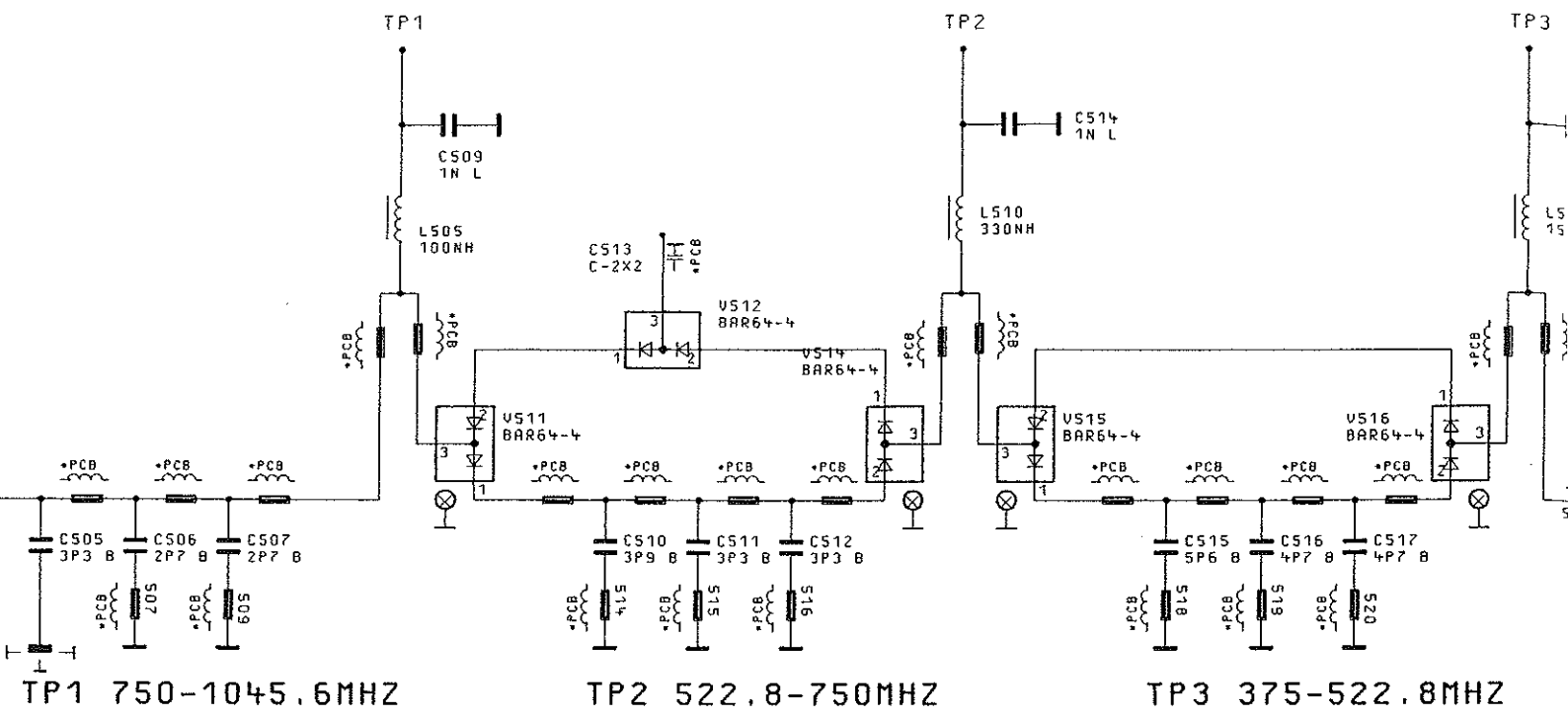

N.F. = NOT FITTED / NICHT BESTUECKT



ACHTUNG: EGB!
ELEKTROSTATISCH GEFÄHRDETE BAUELEMENTE ERFORDERN EINE BESONDERE HANDHABUNG.
ATTENTION ESD!
ELECTROSTATIC SENSITIVE DEVICES REQUIRE A SPECIAL HANDLING

BINDEN
TRIMM
NICHT
FOR BI
TRIMM
NONFIT

C FILTERS

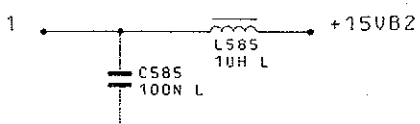
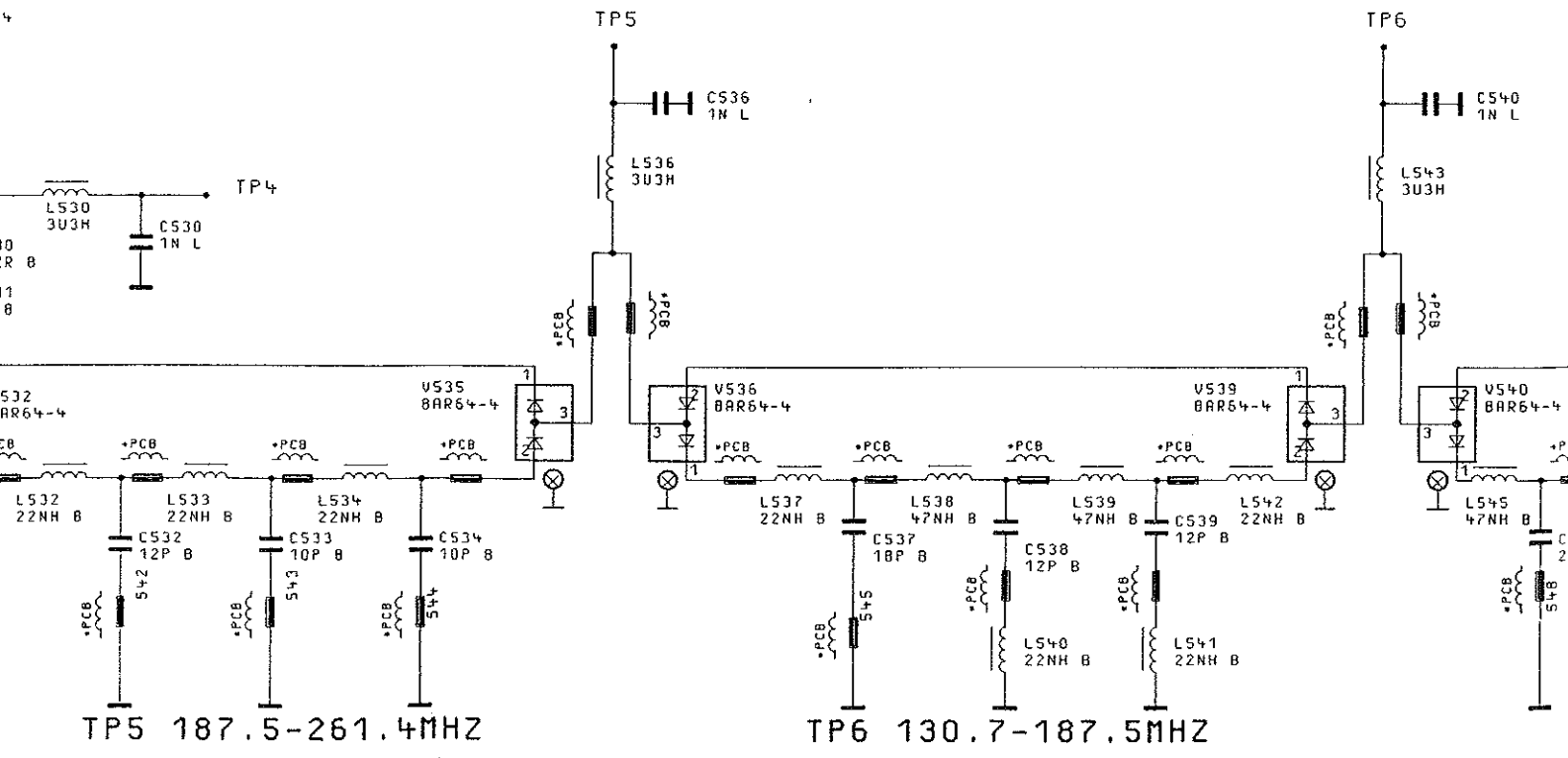
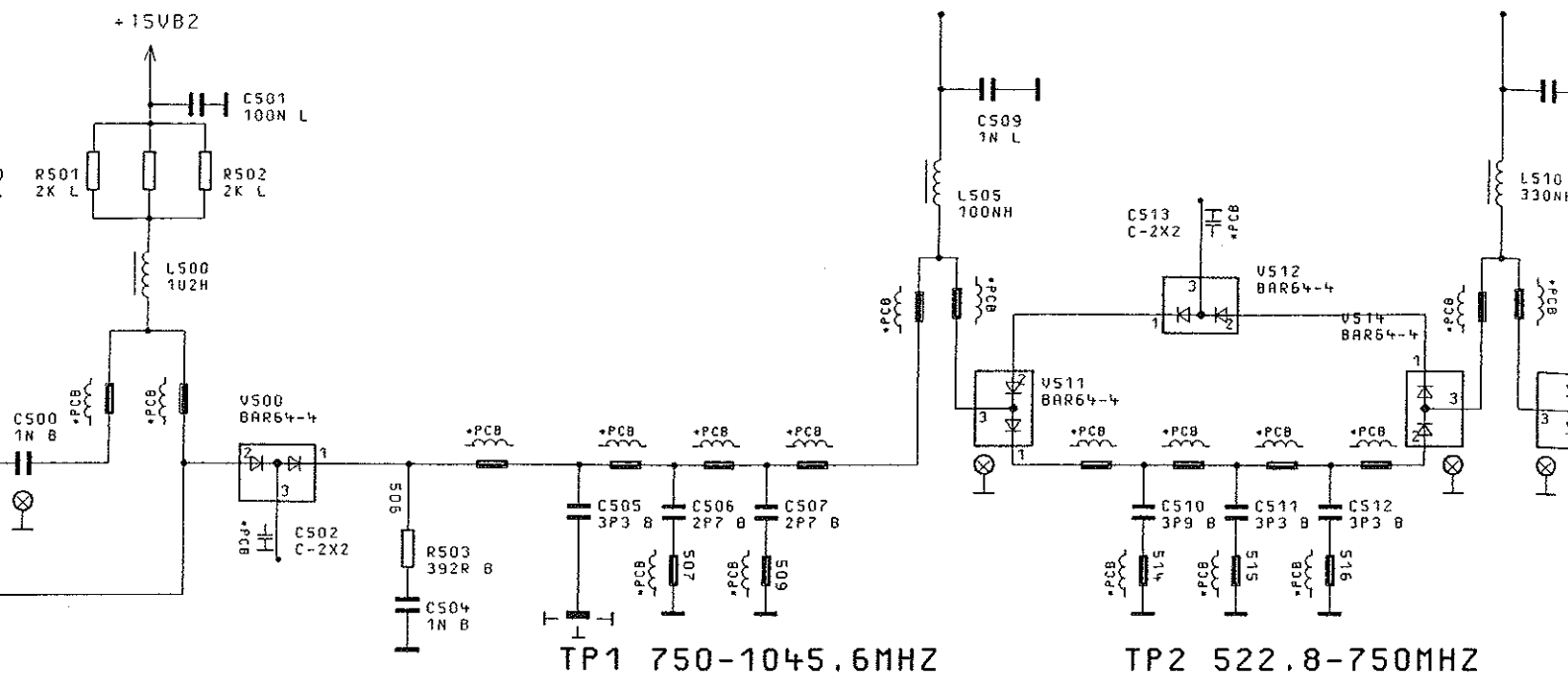

*PCB

- PRINTED ON PCB

*PCB

N.F. - NO



HARMONIC FILTERS

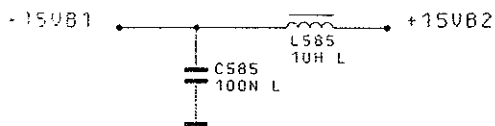
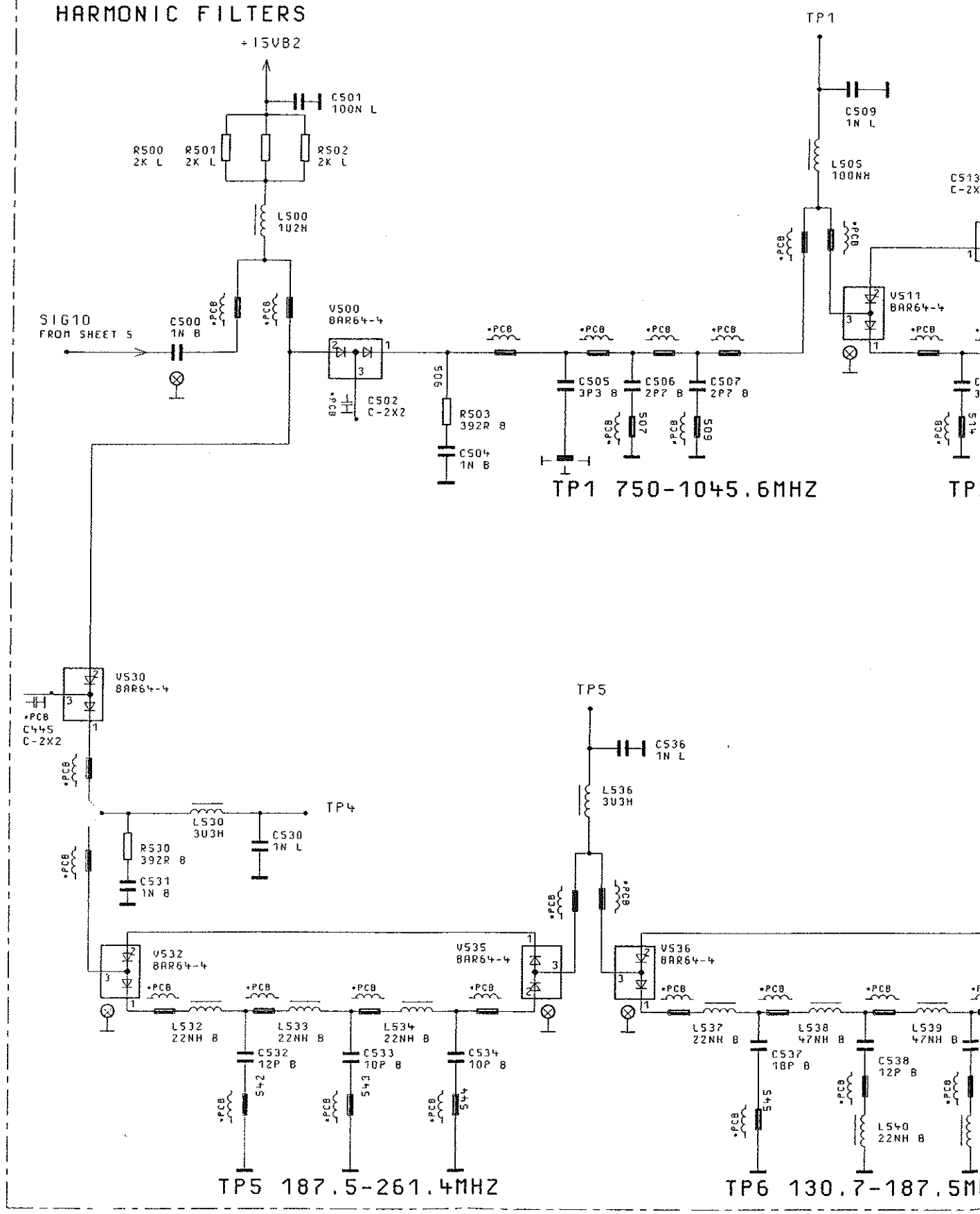

*PCB
 - PRINTED ON PCB
 *PCB

BEHALTEN IIR UNS ALLE RECHTE VOR

R645

PLIFIER

IF-LOWPASS
65MHZ

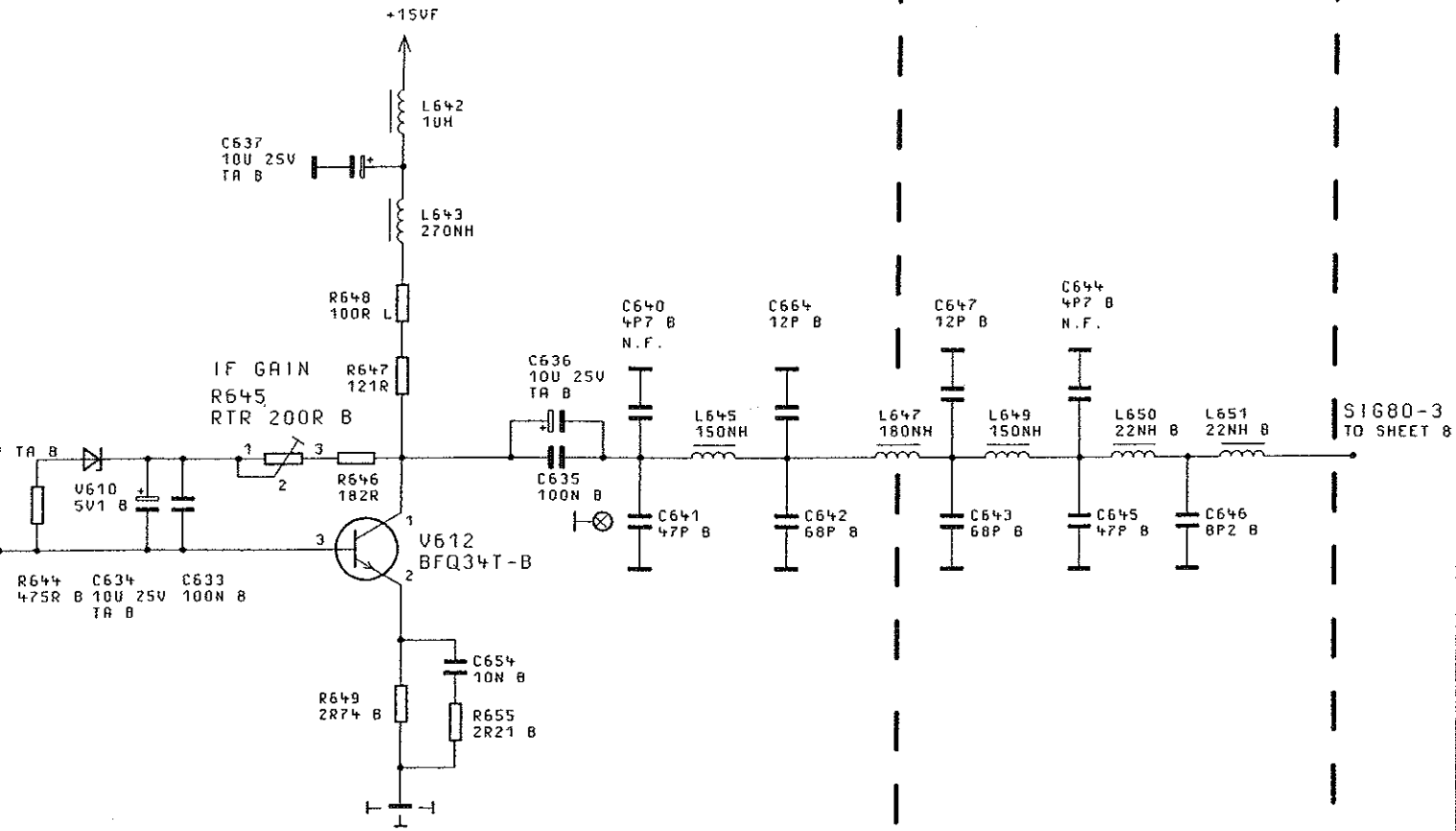

N.F. - NOT FITTED / NICHT BESTUECKT

BINDENDE ANGABEN UEBER VARIANTEN,
TRIMMWERTE, BAUTEILWERTE UND
NICHT BESTUECKTE BAUTEILE SIEHE SA.

FOR BINDING INFORMATION ON MODELS,
TRIMMING AND COMPONENTS VALUES AND
NONFITTED COMPONENTS SEE PARTS LIST.

04/02	03.03.97	E I	MENP	TAG	NAME	BENENNUNG		
			BEARB.		E I	AUSGANGSTEIL 2.08GHZ OUTPUT UNIT 2.08GHZ		
			6EPR.					
			NORM					
			PLOTT	03.03.97				
04/01	16.12.96	E I	 ROHDE & SCHWARZ			ZEICHN.-NR.	BLATT-NR.	
REND. IND.	RENDERUNGS- MITTEILUNG	DATUM				NAME	1062.7005.01S	7+
			ZU GERÄT	SMY	REG.-I.V.	1062.5502	ERSTE Z.	1062.5502

9

10

11

12

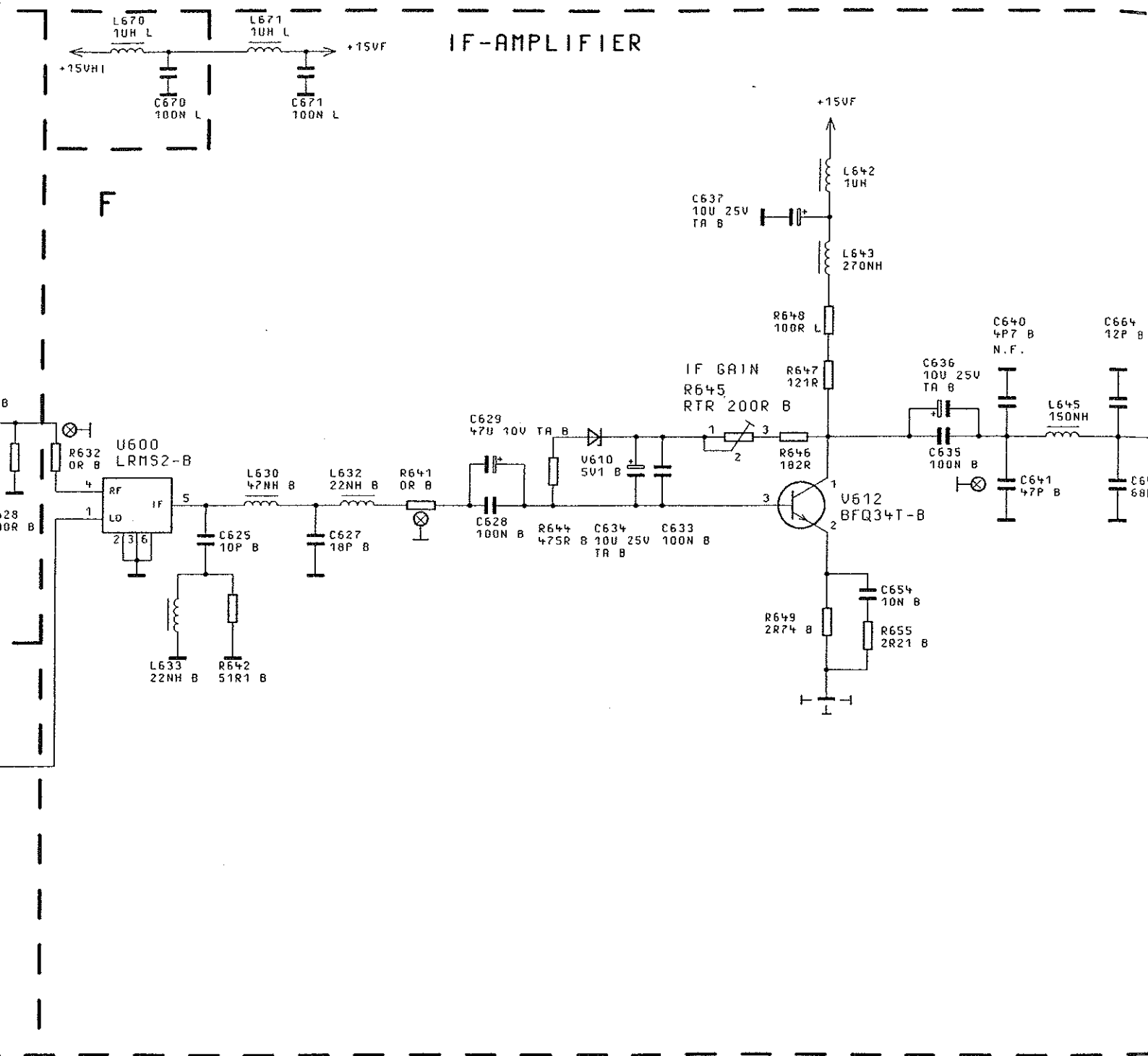



ACHTUNG: EGB!
ELEKTROSTATISCH GEFÄHRDETE
BAUELEMENTE ERFORDERN EINE
BESONDERE HANDHABUNG.

ATTENTION ESD!
ELECTROSTATIC SENSITIVE DEVICES
REQUIRE A SPECIAL HANDLING

N.F. - NOT FITTED / NICHT BESTUECKT

BINDENDE ANGABEN UEBER VARIANTEN,
TRIMMWERTE, BAUTEILWERTE UND
NICHT BESTUECKTE BAUTEILE SIEHE SA.

FOR BINDING INFORMATION
TRIMMING AND COMPONENTS
NONFITTED COMPONENTS SEE

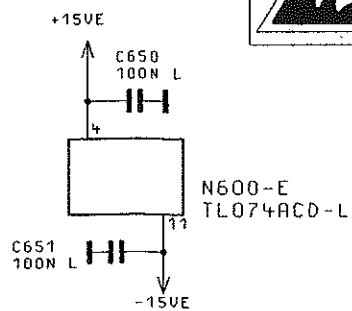

04/02	03.03.97	E I	MENP	TAG	NAME
			BEARB.		E I
			GEPR.		
			NORM		
			PLOTT	03.03.97	
04/01	16.12.96	E I			
REND. IND.	ÄNDERUNGS- MITTEILUNG	DATUM	NARE	 ROHDE & SCHWARZ ZU BERREI SMY	

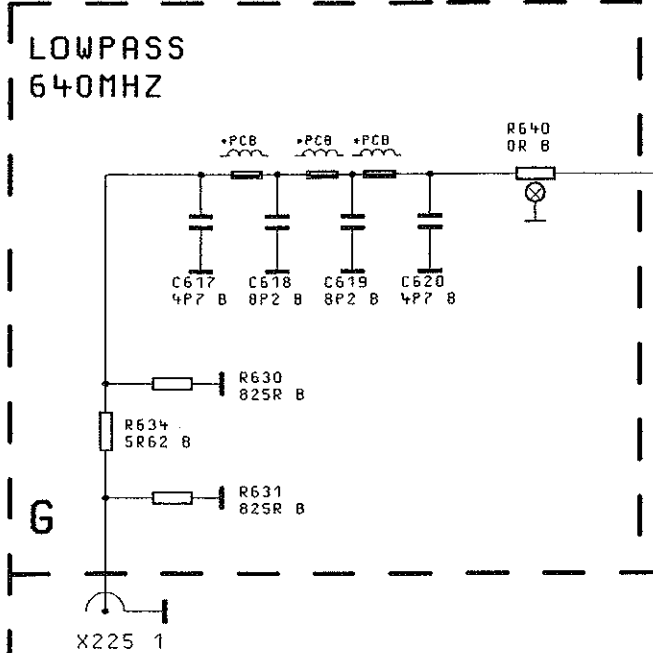
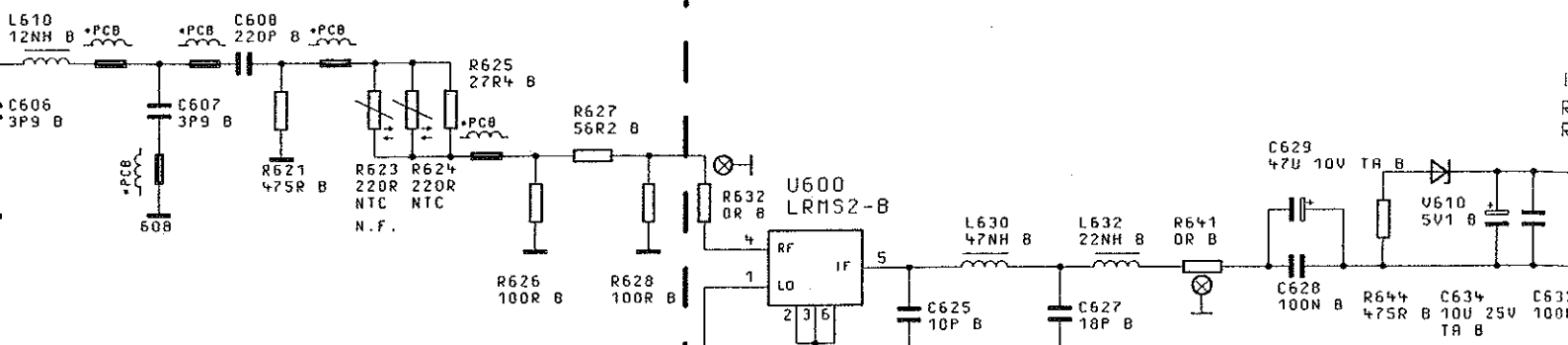
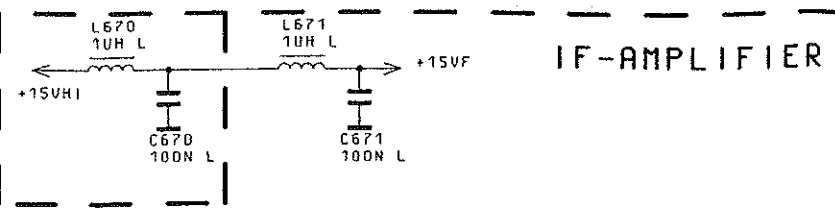
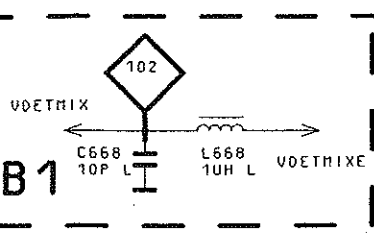

X225 1
REF640
640MHZ
9...12DBM

ACHTUNG: EGB!
ELEKTROSTATISCH GEFÄHRDETE
BAUELEMENTE ERFORDERN EINE
BESONDERE HANDHABUNG.
ATTENTION ESD!
ELECTROSTATIC SENSITIVE DEVICES
REQUIRE A SPECIAL HANDLING

N.F. - NO
BINDENDE A
TRIMMWERTE
NICHT BESTE

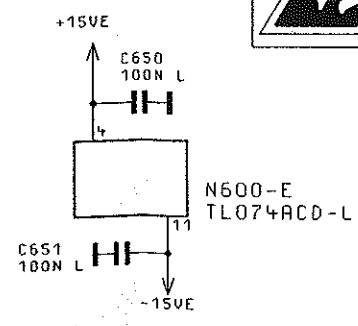
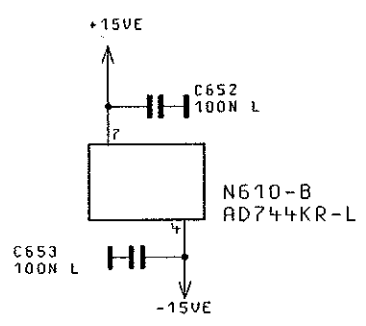

04/02	
04/01	
REND.	
IND.	

P628
P620 P621

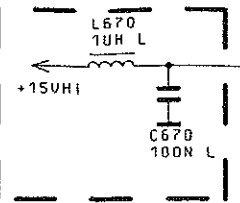
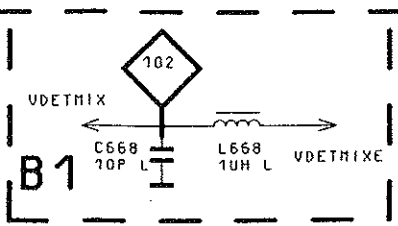
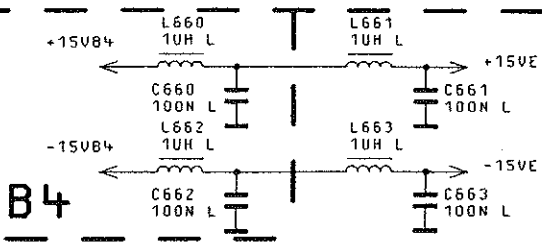

RF-LOWPASS

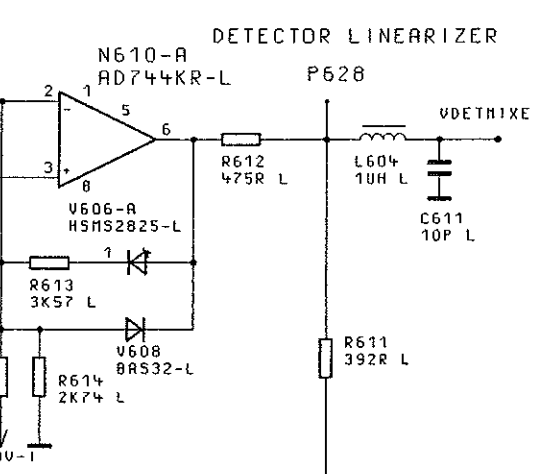
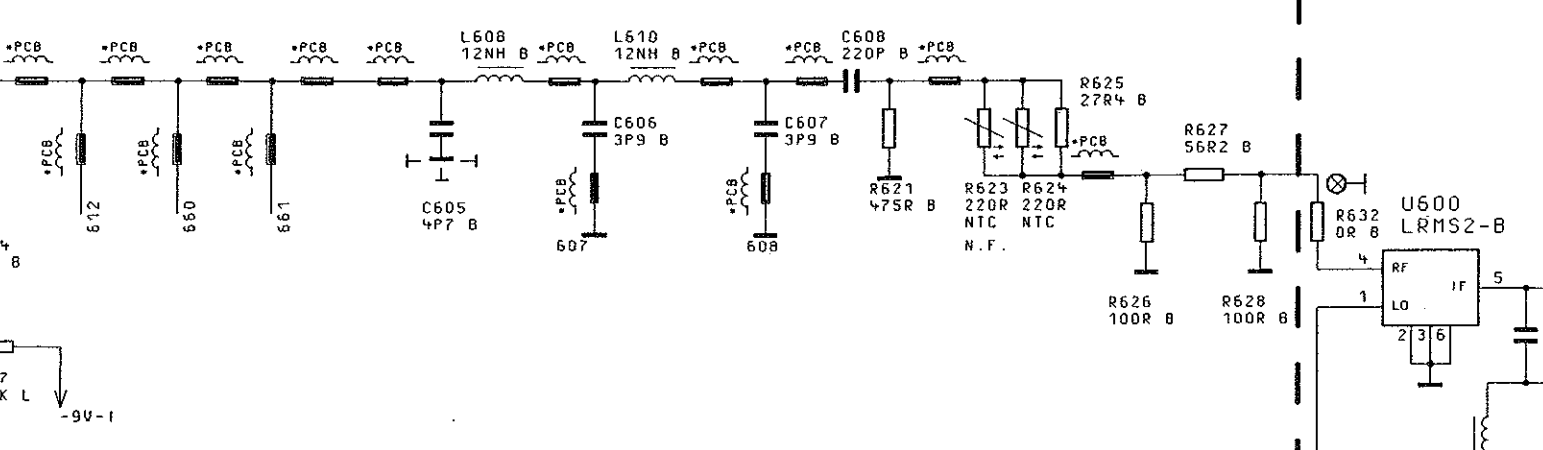

LOWPASS
640MHZ

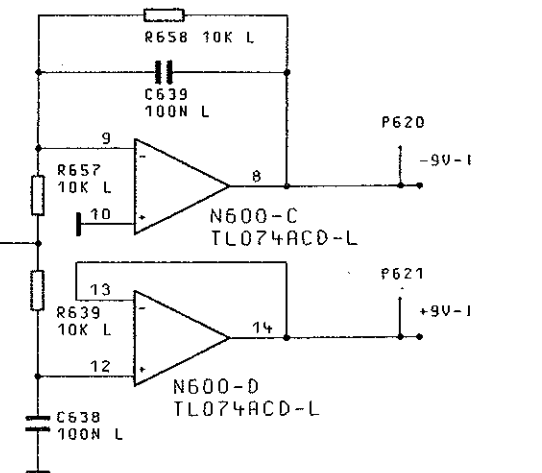
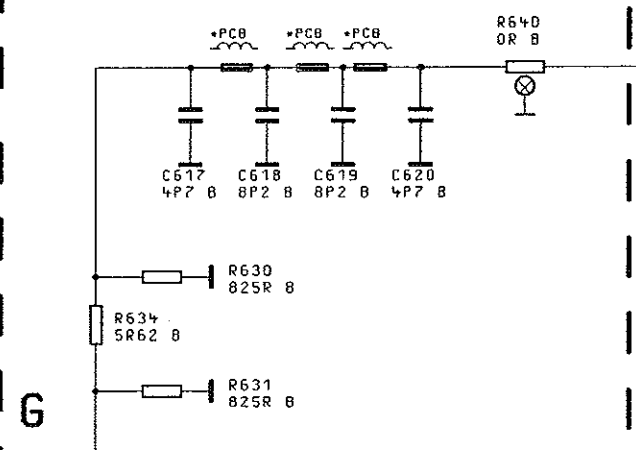

X225 1
REF640
640MHZ
9...12DBM

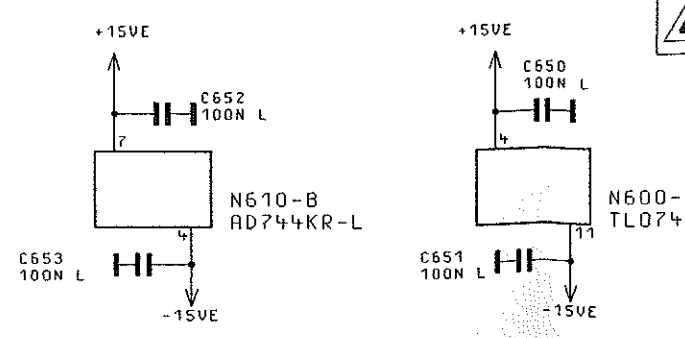

P600
P601

P628
P620 P621

AMPLIFIER 4

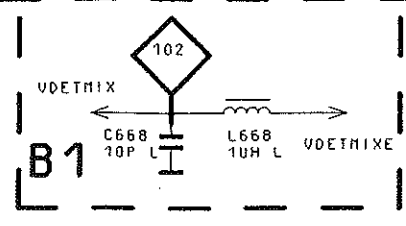
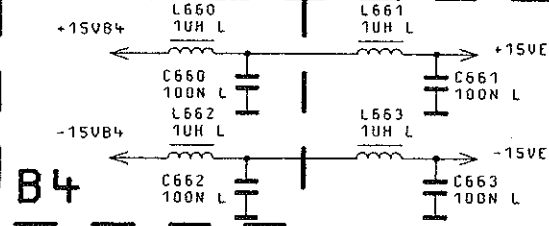
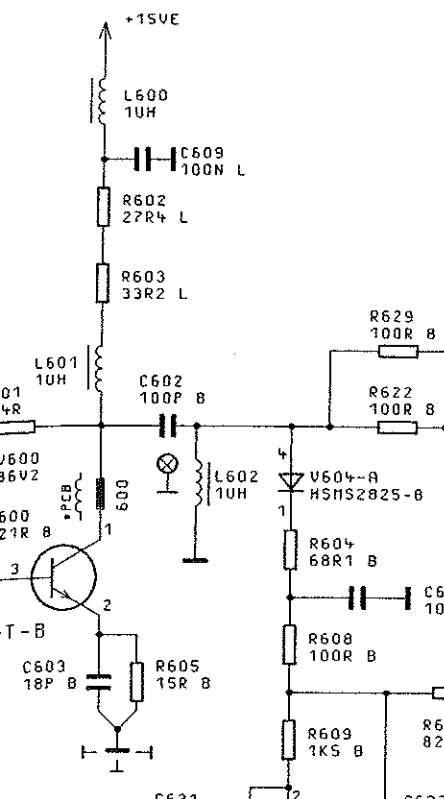

RF-LOWPASS

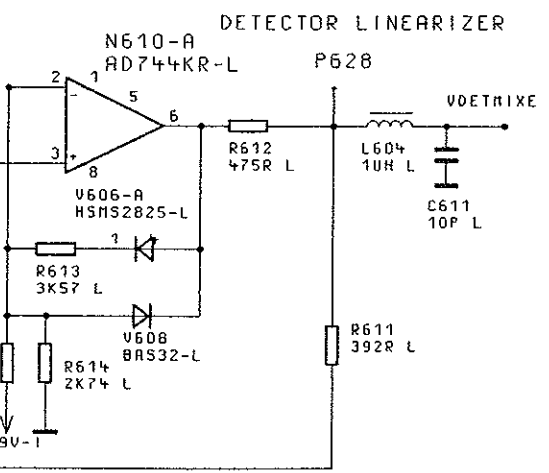
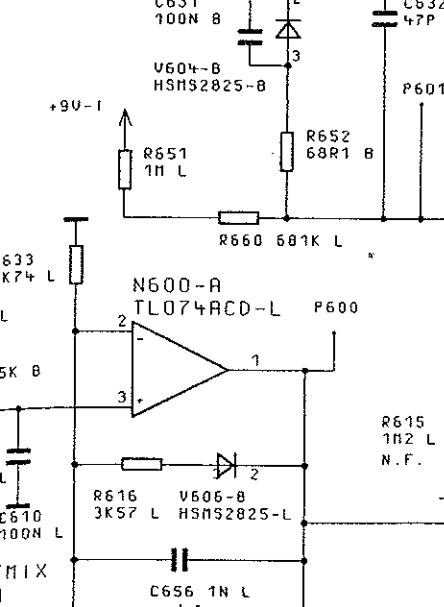
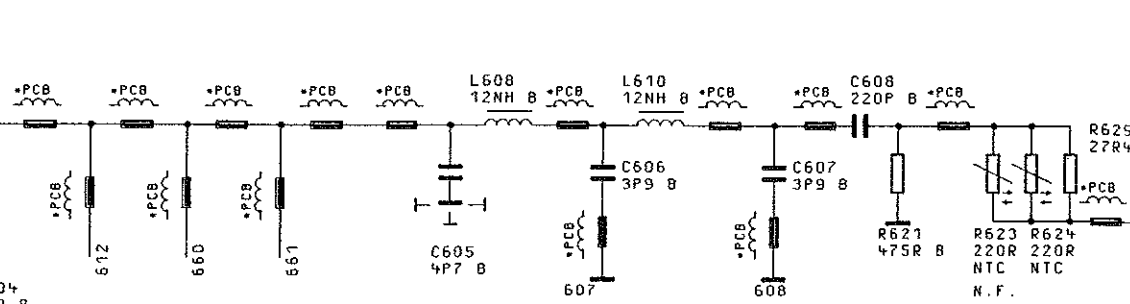

LOWPASS 640MHZ

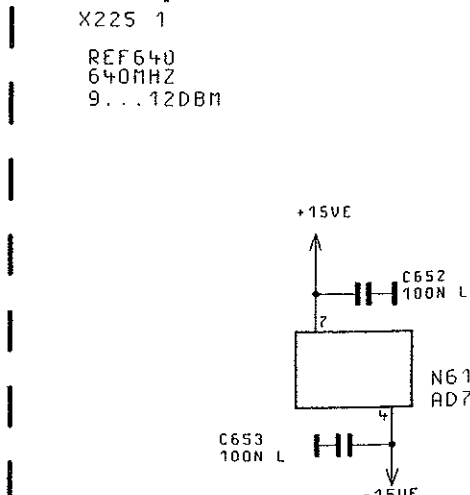
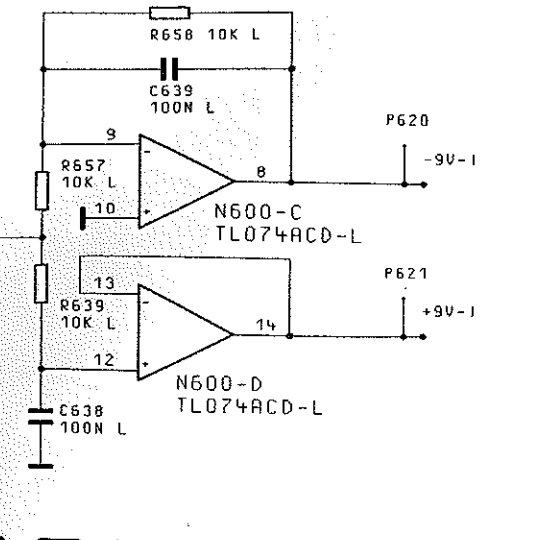
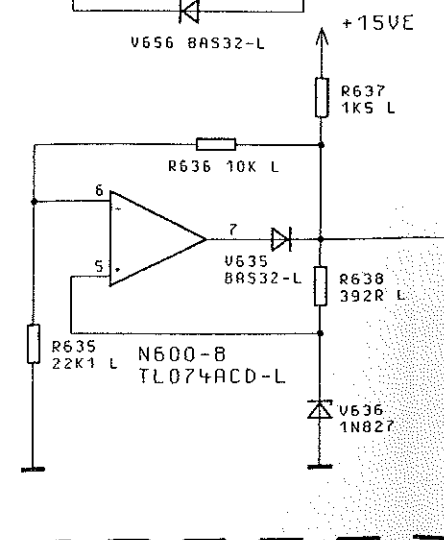
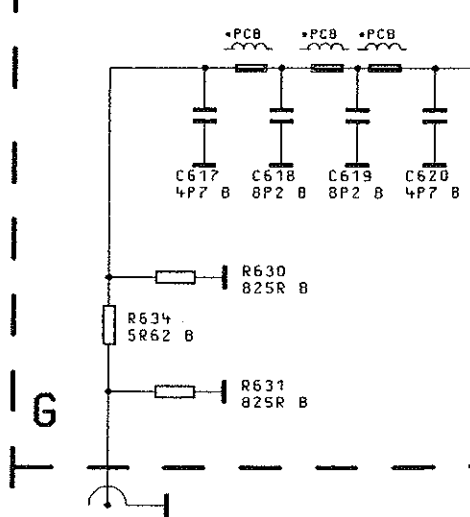

R619

P600
P601

P528
P620 P621

RF-AMPLIFIER 4

E

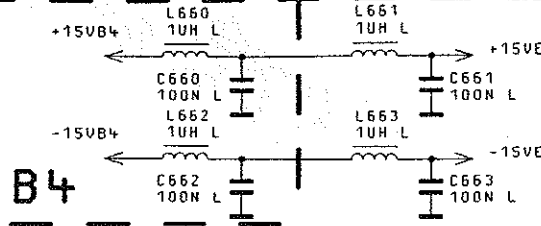

RF-LOWPASS

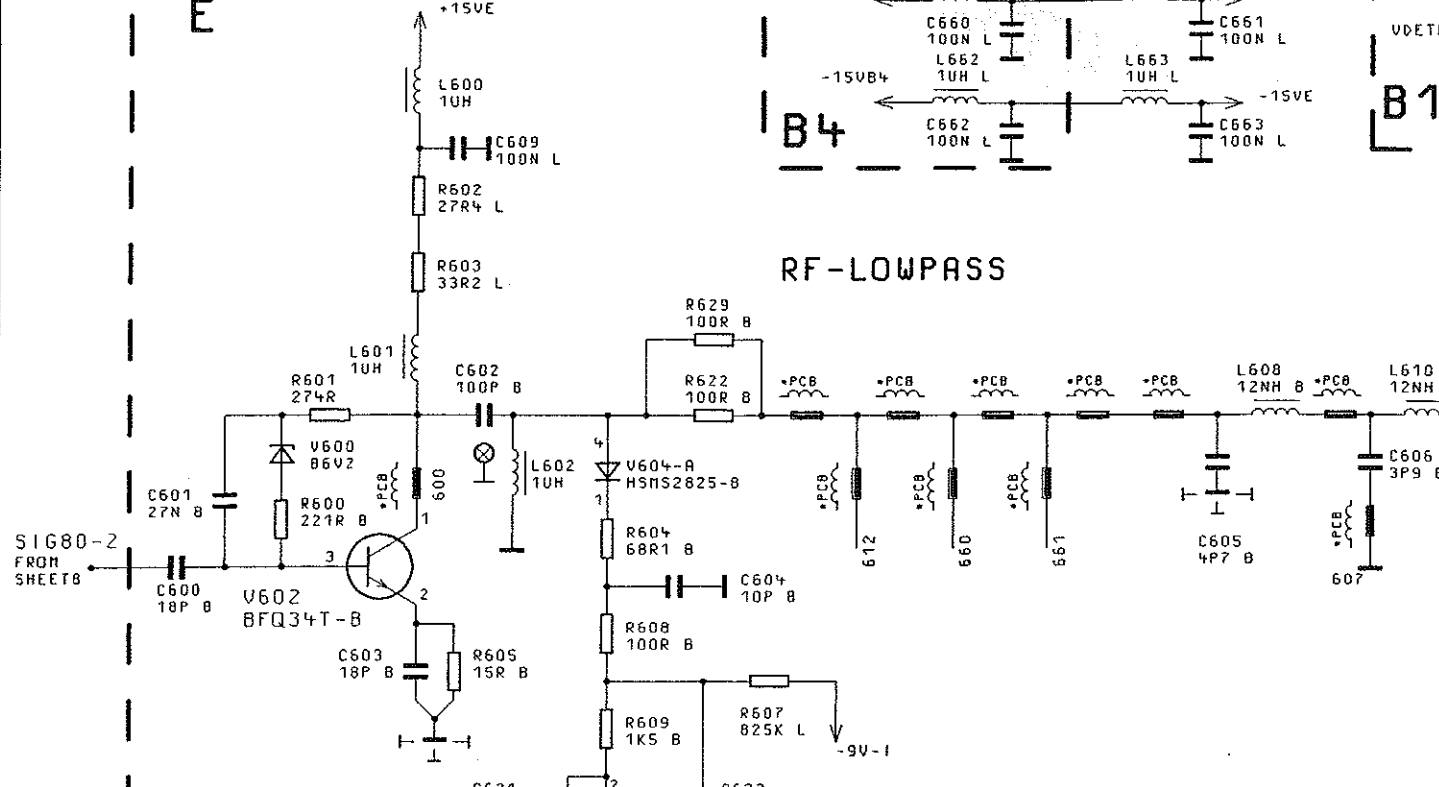

DETECTOR LINEARIZER

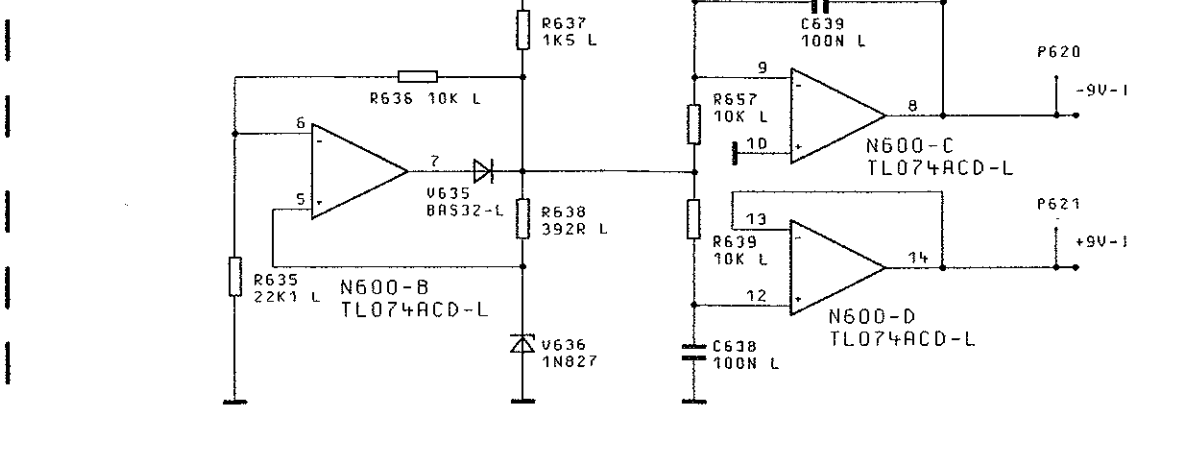
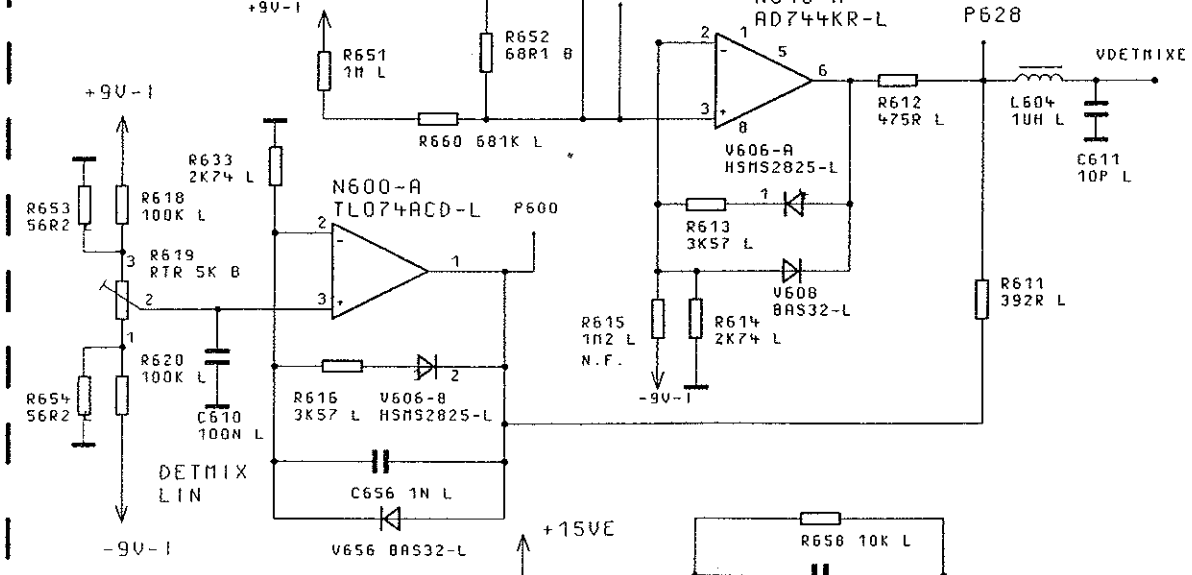

BEHALTEN WIR UNS ALLE RECHTE VOR

ZEICHN.-NR.

PLIFIER 5

SWITCH A

H

SWITCH B

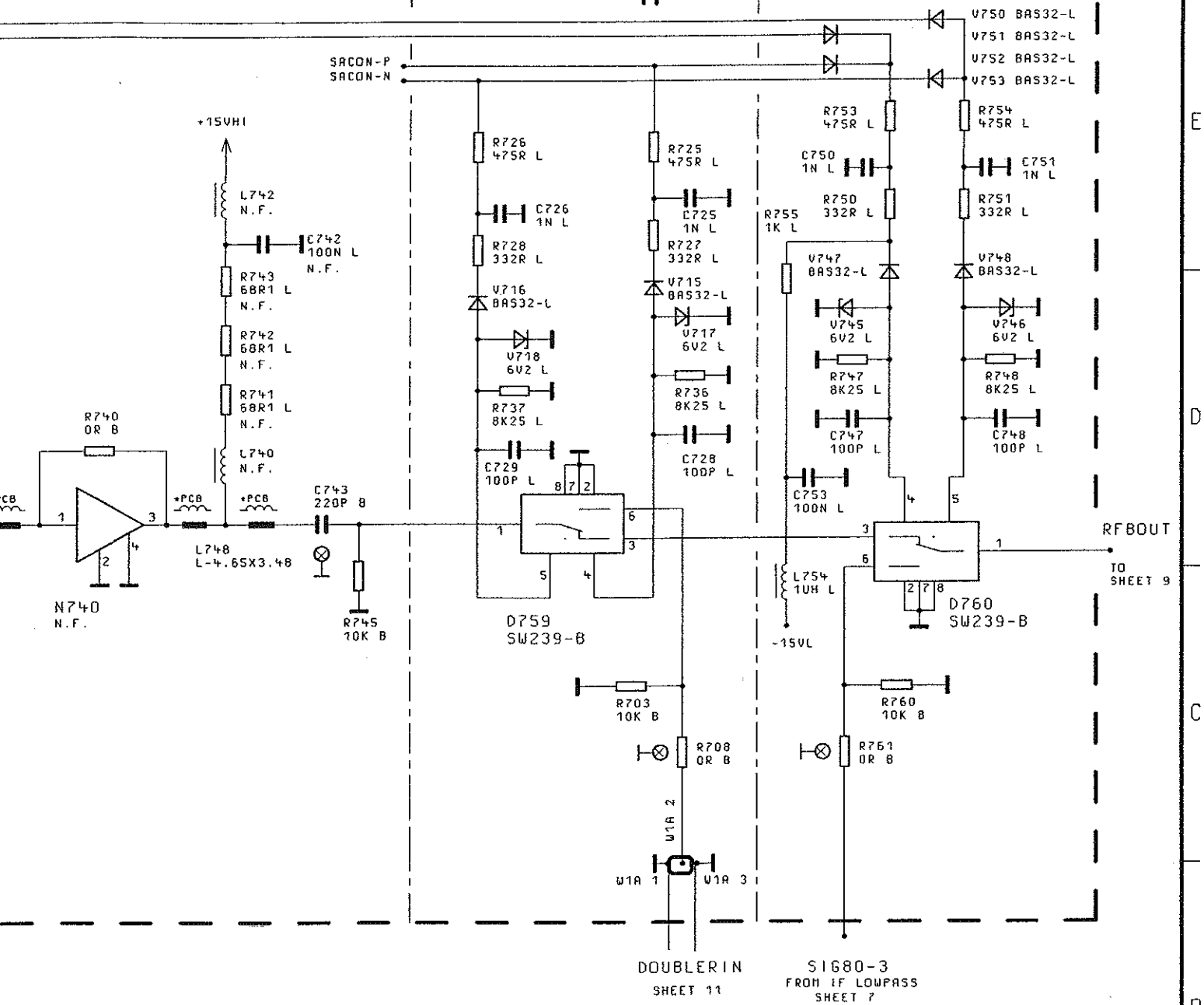

BINDENDE ANGABEN UEBER VARIANTEN,
TRIMMWERTE, BAUTEILWERTE UND
NICHT BESTUECKTE BAUTEILE SIEHE SA.

FOR BINDING INFORMATION ON MODELS,
TRIMMING AND COMPONENTS VALUES AND
NONFITTED COMPONENTS SEE PARTS LIST.

04/02		03.03.97	E I	MENP	TAG	NAME	BENENNUNG		
				BEARB.		E I	AUSGANGSTEIL 2.086GHZ OUTPUT UNIT 2.086GHZ		
				GEPR.					
				NORM					
				PLOTT	03.03.97				
04/01		16.12.96	E I	ROHDE & SCHWARZ			ZEICHN.-NR.	1062.7005.01S	
AEND. IND.	AENDERUNGS-MITTEILUNG	DATUM	NAME				REG. I.V.	1062.5502	ERSTE Z.
							BLATT-NR.	8+	
							V. BL.		
				ZU GERÄT	SMY				
			9				10		
							11		
								12	

RF AMPLIFIER 5

SWITCH A

H

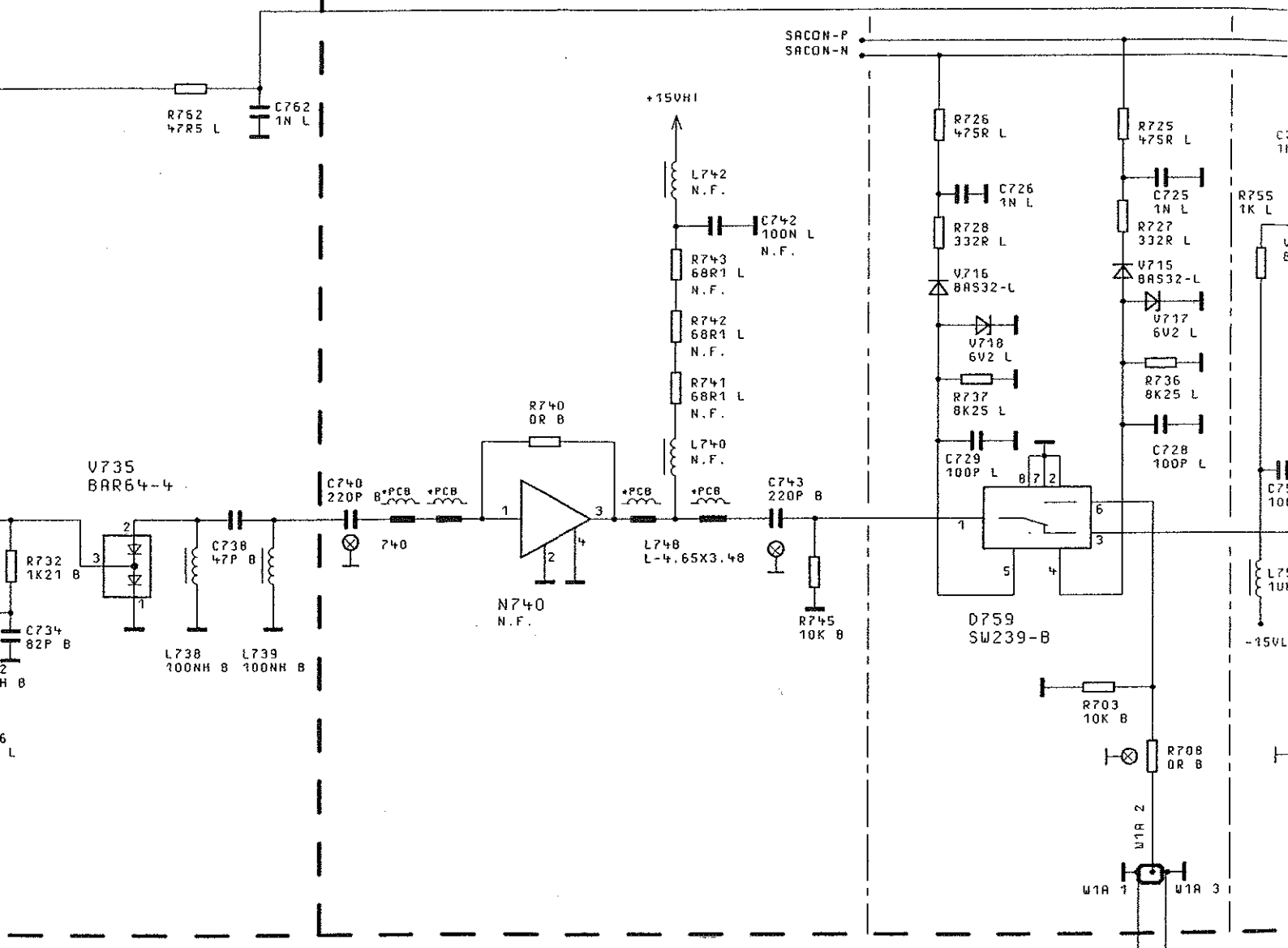

DOUBLERIN
SHEET 11

N.F. - NOT FITTED / NICHT BESTUECKT

BINDENDE ANGABEN UEBER VARIANTEN,
TRIMMWERTE, BAUTEILWERTE UND
NICHT BESTUECKTE BAUTEILE SIEHE SA.

FOR BINDING INFORMATION ON MODELS,
TRIMMING AND COMPONENTS VALUES AND
NONFITTED COMPONENTS SEE PARTS LIST.

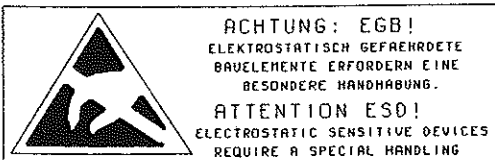

04/02		03.03.97	E I	MENP	TAG	NAME	BEMERKUNG
				BEARB.		E I	AUSGANG OUTPUT U
				GEPR.			
				NORM			
				PLOTT	03.03.97		
04/01		16.12.96	E I				ZEICHN.-NR.
ÄND. IND.	ÄNDERUNGS- MITTEILUNG	DATUM	NAMEN				10
				ZU SERRET		SMY	REG. I. V. 1062

RF AMPLIFIER 5

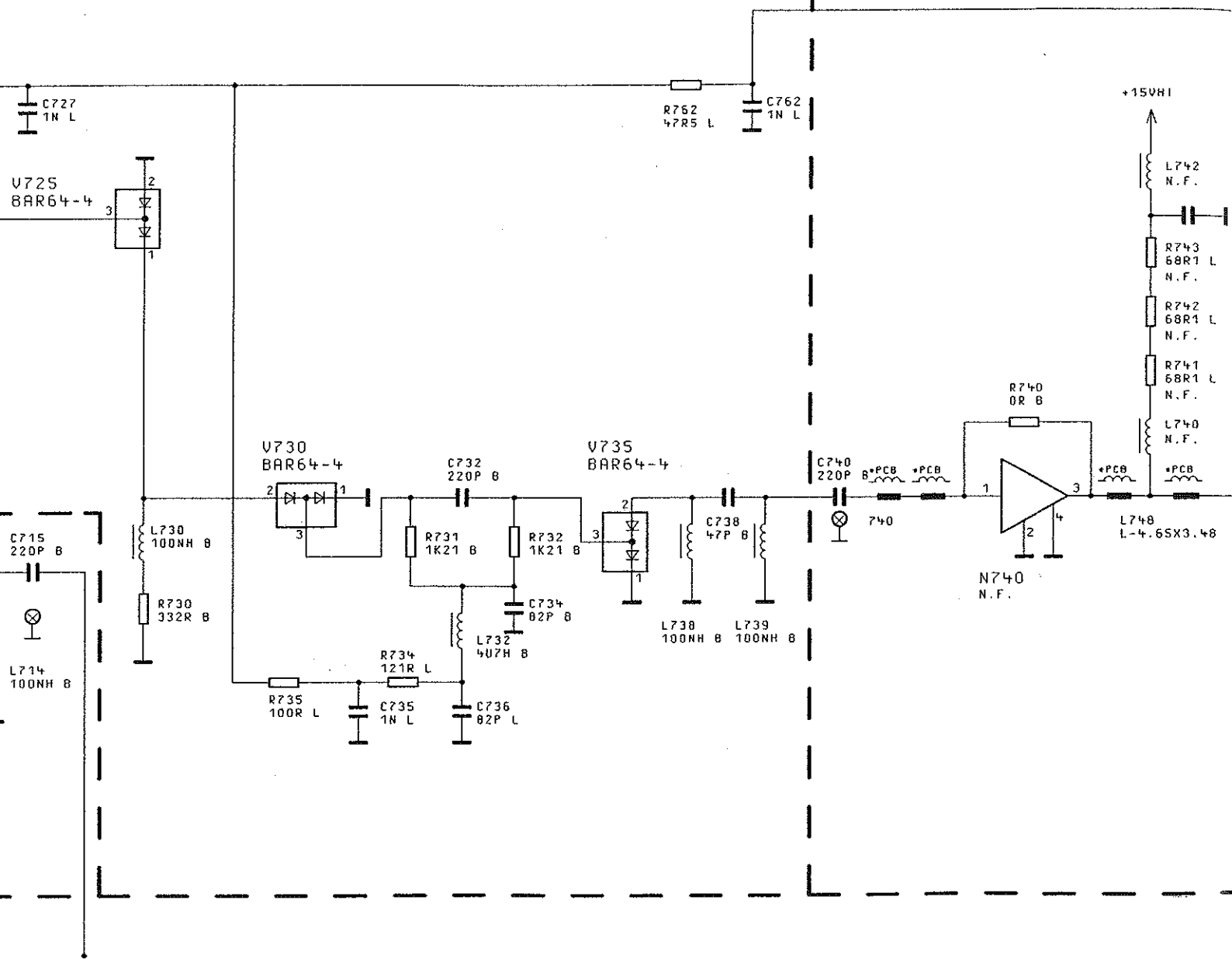

SIG80-2

TO RF/AMPLIFIER 4
SHEET 7

N.F. - NOT FITTED / NICHT BESTUECKT

BINDENDE ANGABEN UEBER VA
TRIMMWERTE, BAUTEILWERTE
NICHT BESTUECKTE BAUTEILE



ACHTUNG: EGB!
ELEKTROSTATISCH GEFÄHRDETE
BAUELEMENTE ERFORDERN EINE
BESONDERE HANDABUNG.
ATTENTION ESD!
ELECTROSTATIC SENSITIVE DEVICES
REQUIRE A SPECIAL HANDLING

04/02		03
04/01		16
REND. IND.	ÄNDERUNGS- MITTEILUNG	

CH D

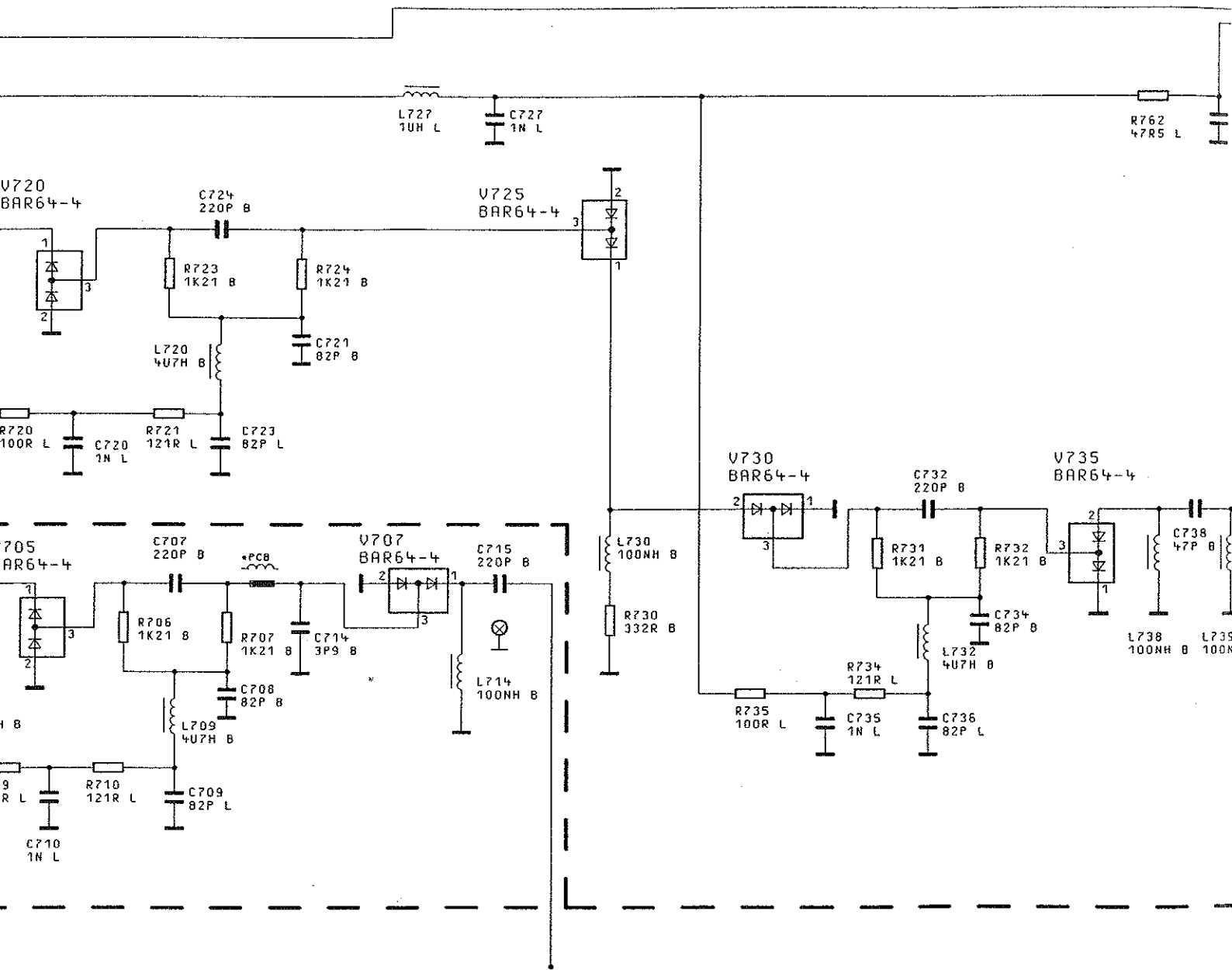

SIG80-2
TO RF/AMPLIFIER 4
SHEET 7

N.F. - NOT FITTED /

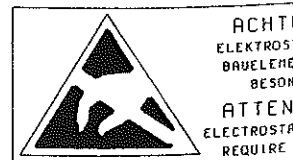

D SWITCH D

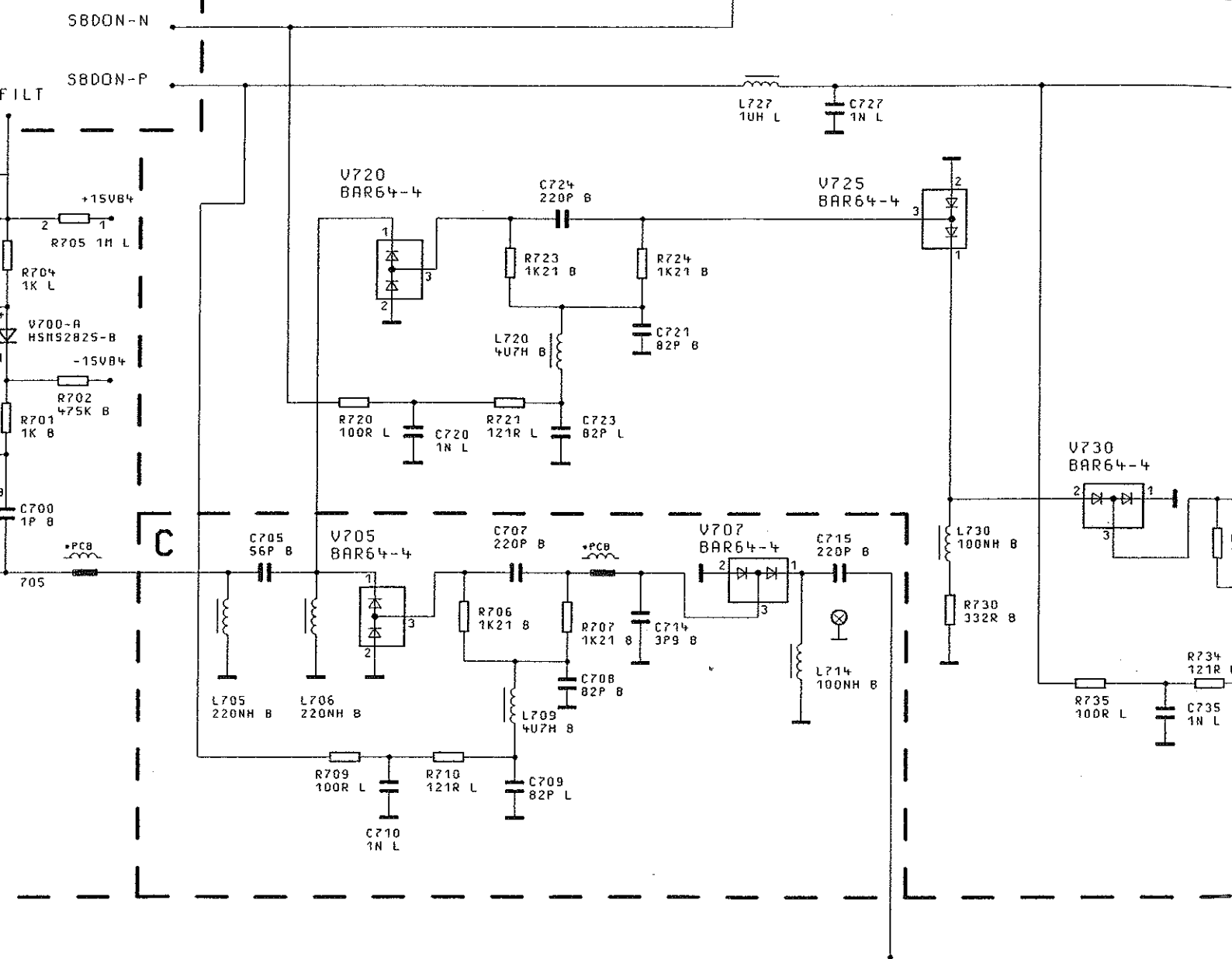

S1680-2
TO RF/AMPLIFIER 4
SHEET 7

BEHALTEN WIR UNS ALLE RECHTE VOR

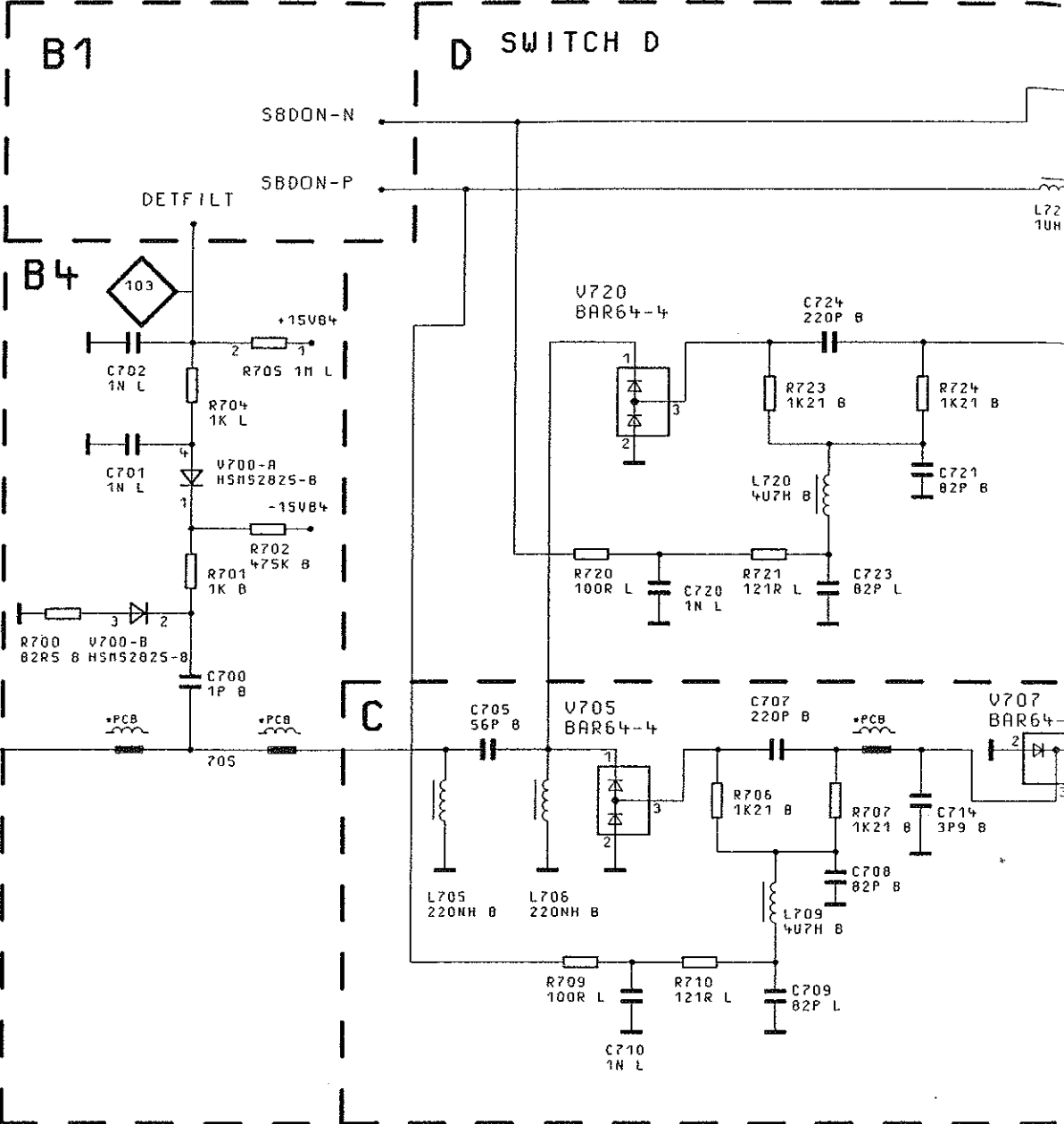

BEHALTEN MIR UNS ALLE RECHTE VOR
FUER DIESE UNTERLAGE

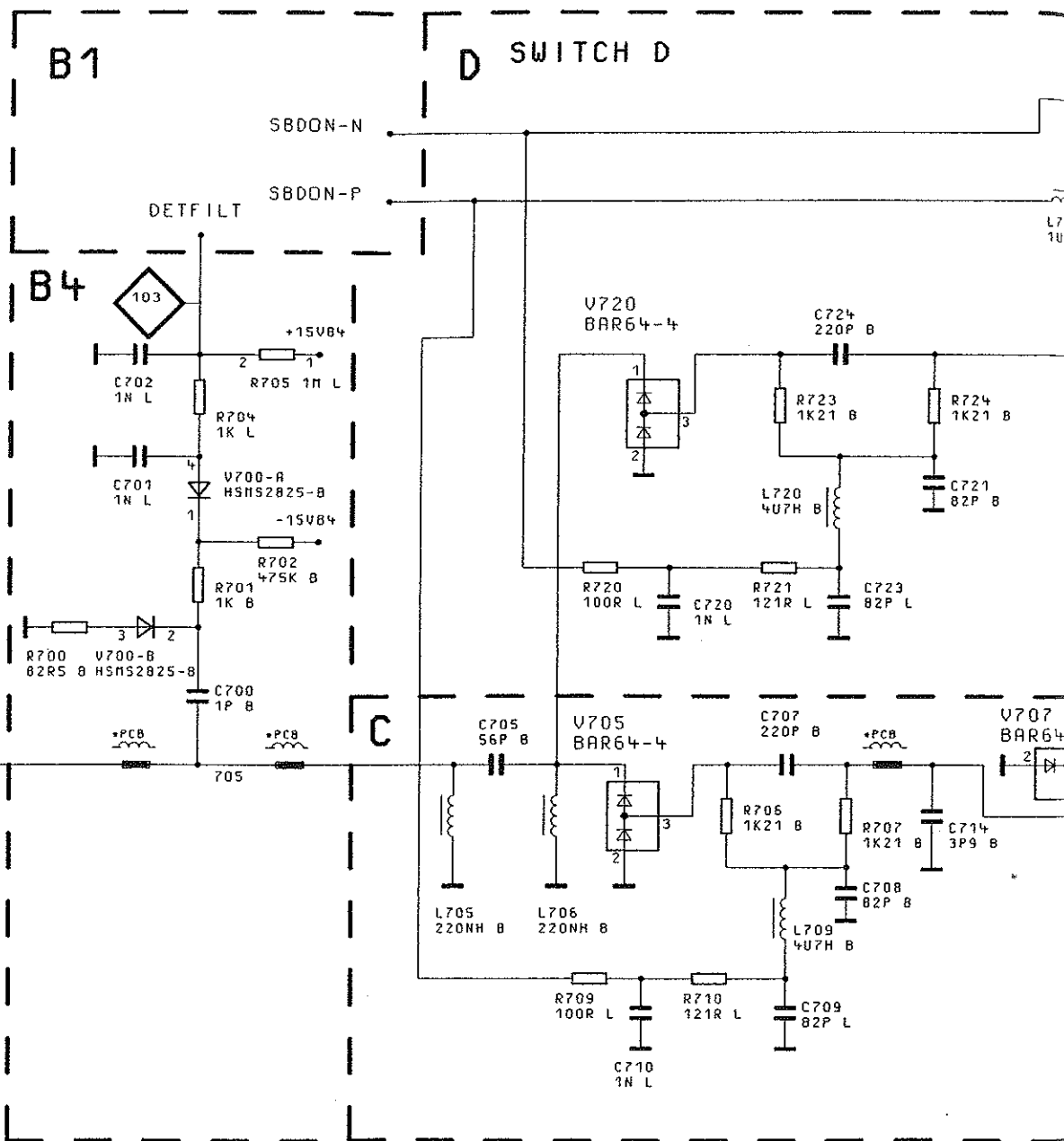



BINDENDE ANGABEN UEBER VARIANTEN,
TRIMMWERTE, BAUTEILWERTE UND
NICHT BESTUECKTE BAUTEILE SIEHE SA.

FOR BINDING INFORMATION ON MODELS,
TRIMMING AND COMPONENTS VALUES AND
NONFITTED COMPONENTS SEE PARTS LIST.

RF AMPLIFIER 13

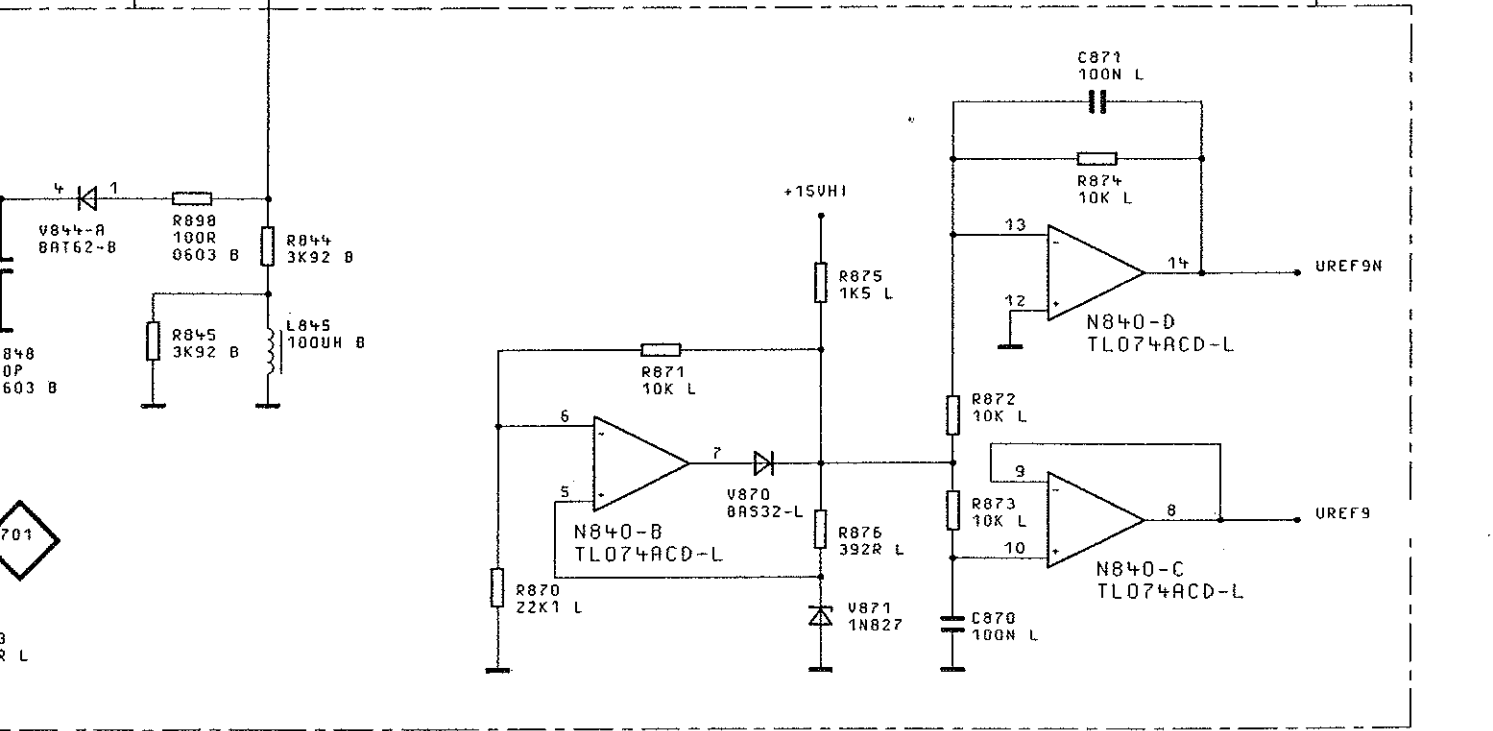
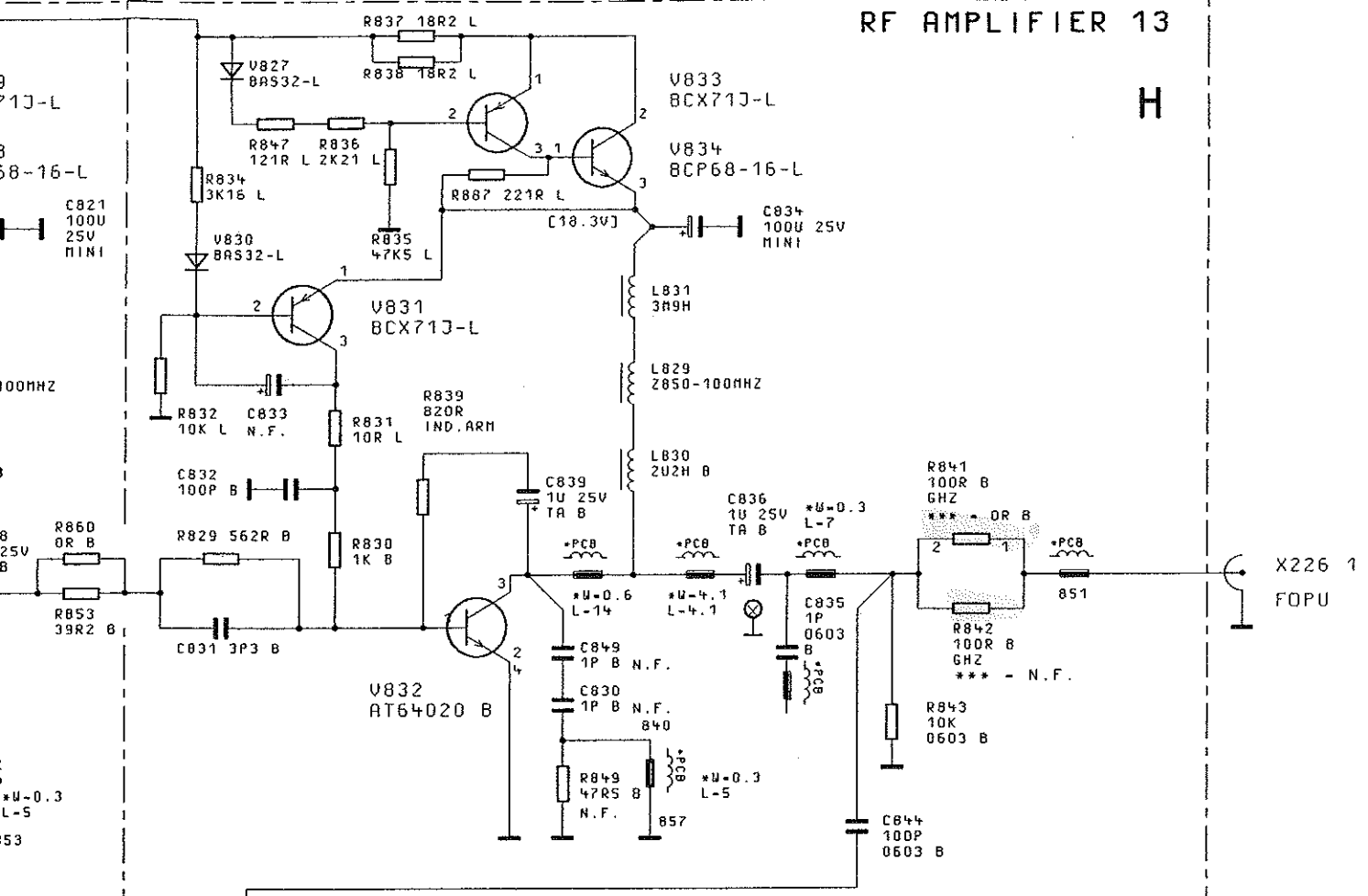
H



04/02	03.03.97	E I	MENP	TAG	NAME	BEKENNUNG
			BEARB.		E I	
			GEPR.			
			NORM			
			PLOTT	03.03.97		
04/01	16.12.96	E I				ZEICHN.-NR.
REND. IND.	ÄNDERUNGS- MITTEILUNG	DATUM				NAME
			ZU SERAET	SMY	REG. I. V.	1062.5502
					ERSTE Z.	1062.5502

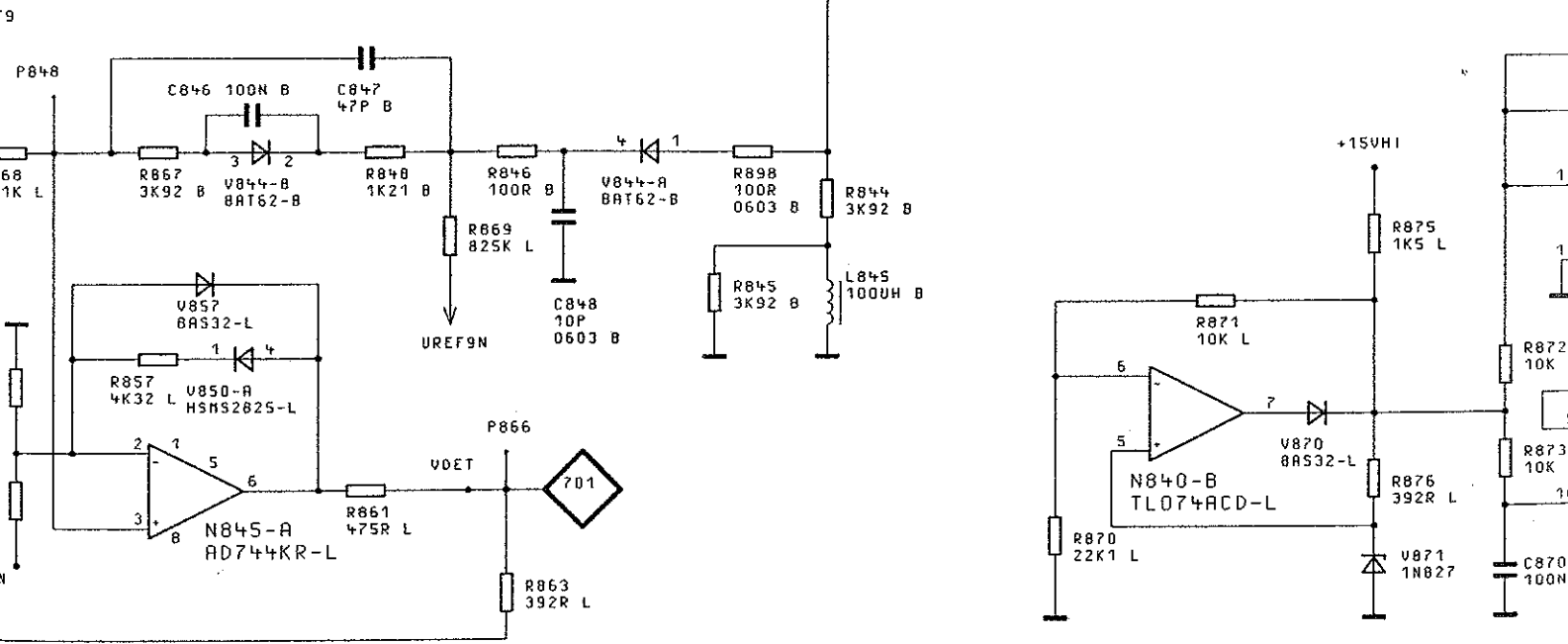
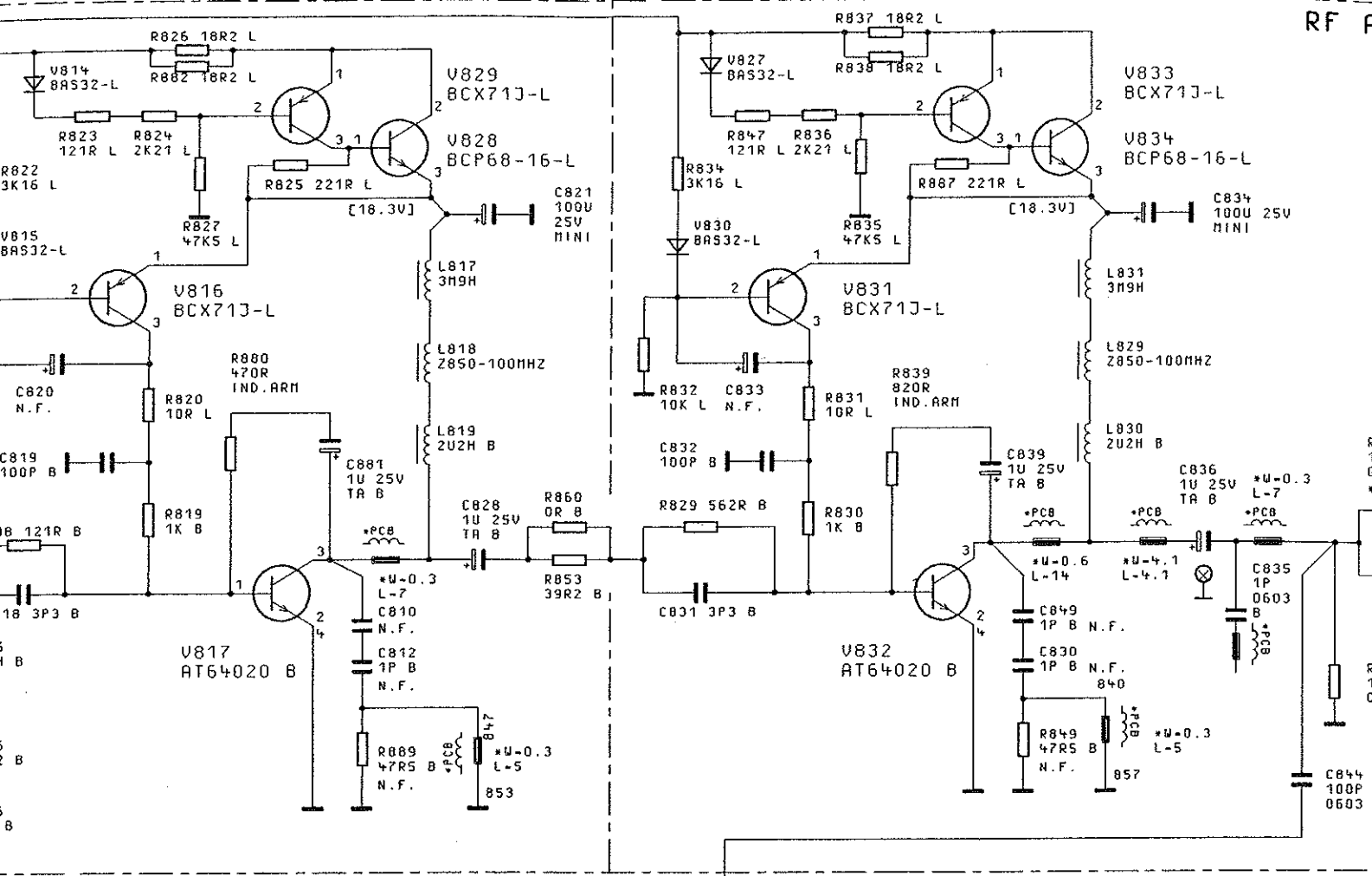

N.F. - NOT FITTED / NICHT BESTUECKT

*** - WITH/MIT OPTION SHY-B40



ACHTUNG: EGB!
ELEKTROSTATISCH GEFÄHRDETE
BAUELEMENTE ERFORDERN EINE
BESONDERE HANDHABUNG.
ATTENTION ESD!
ELECTROSTATIC SENSITIVE DEVICES
REQUIRE A SPECIAL HANDLING

04/02	03.03.97	E I	MENP	TAG	NAME	BENENNUNG
			BEARB.		E I	AUSGABE OUTPUT
			GEPR.			
			NORM			
			PLOTT	03.03.97		
04/01	16.12.96	E I				ZEICHN.-NR.
REND. IND.	RENDERUNGS-MITTEILUNG	DATUM	NAME	ROHDE&SCHWARZ		REG. I. V. 106
			ZU GERÄT	SMY		

AMPLIFIER 12

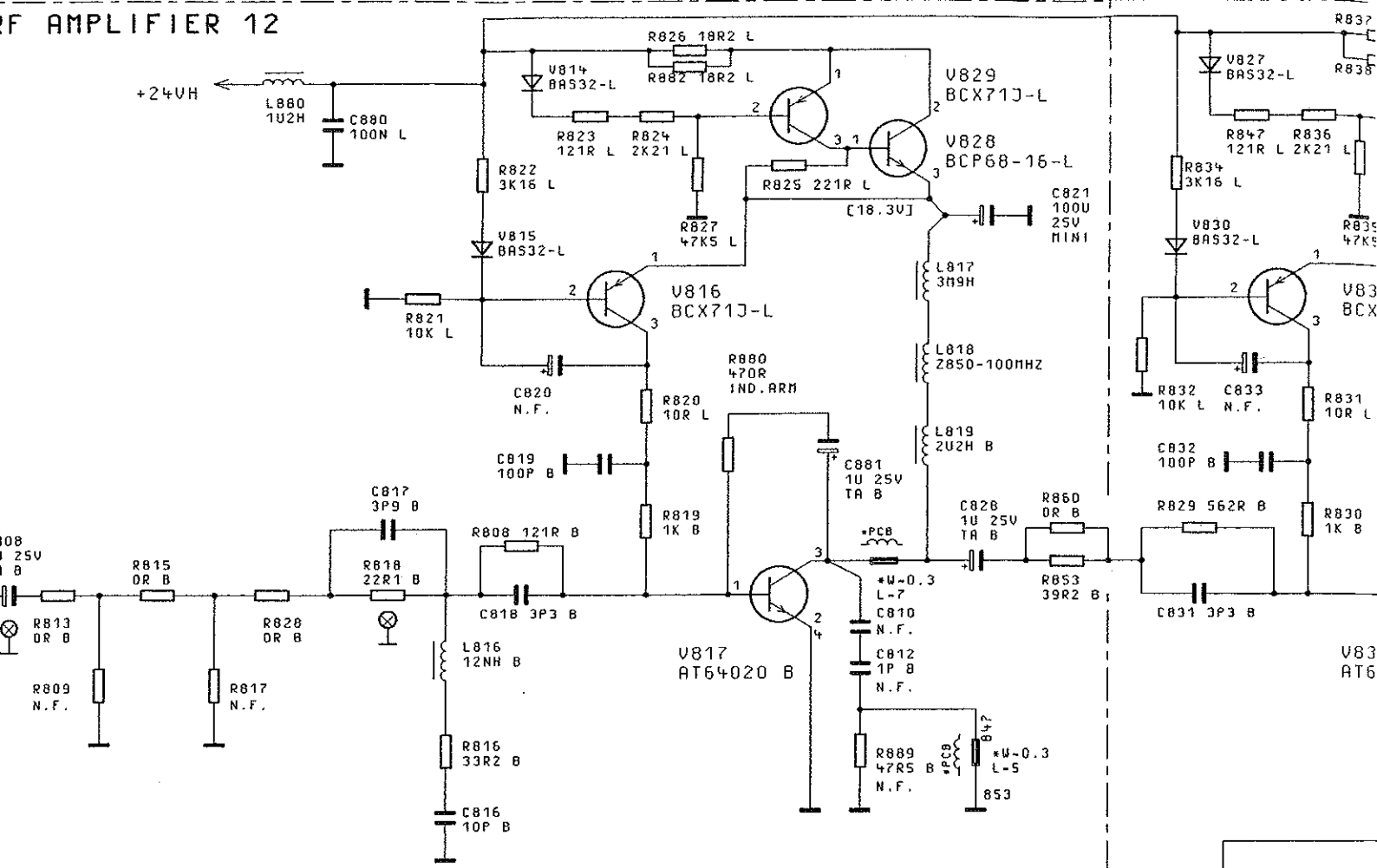

RECTOR LINEARIZER

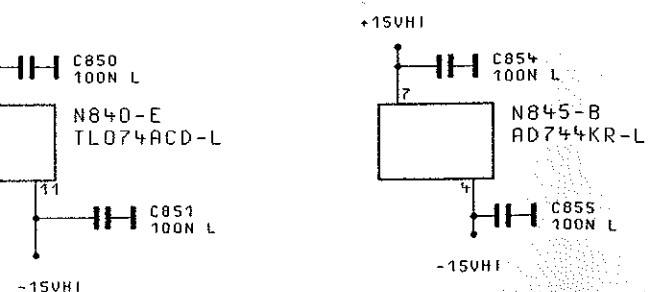
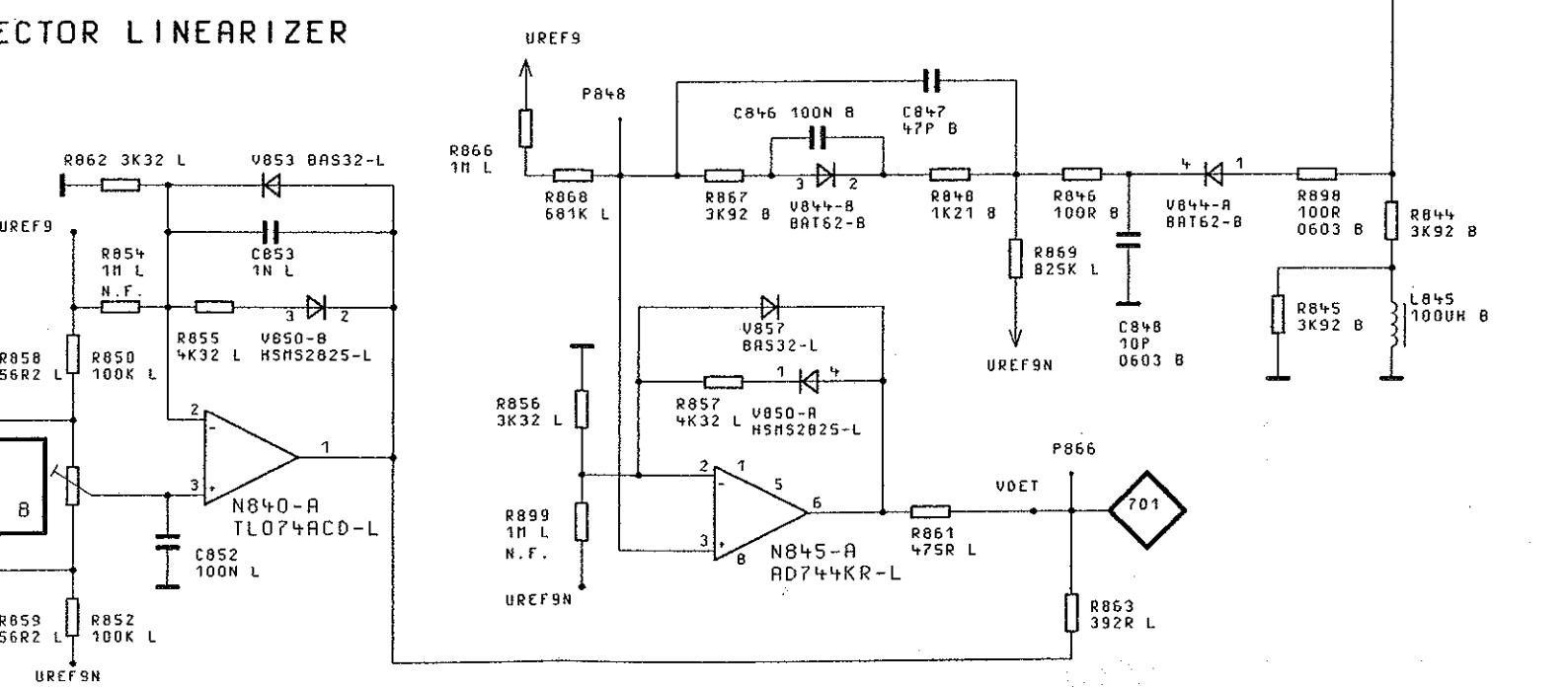

N.F. - NOT FITTED / NICHT BESTUECKT
 *** - WITH/MIT OPTION SMY-B40

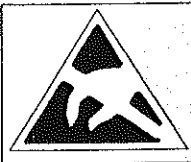

ACHTUNG: EGB!
 ELEKTROSTATISCH GEFÄHRDETE
 BAUELEMENTE ERFORDERN EINE
 BESONDERE HANDhabUNG.
ATTENTION ESD!
 ELECTROSTATIC SENSITIVE DEVICES
 REQUIRE A SPECIAL HANDLING

04/02		03.03.9
04/01		16.12.9
REND. IND.	BEREICHUNG- MITTEILUNG	DATUM

AMPLIFIER 11

RF AMPLIFIER 12

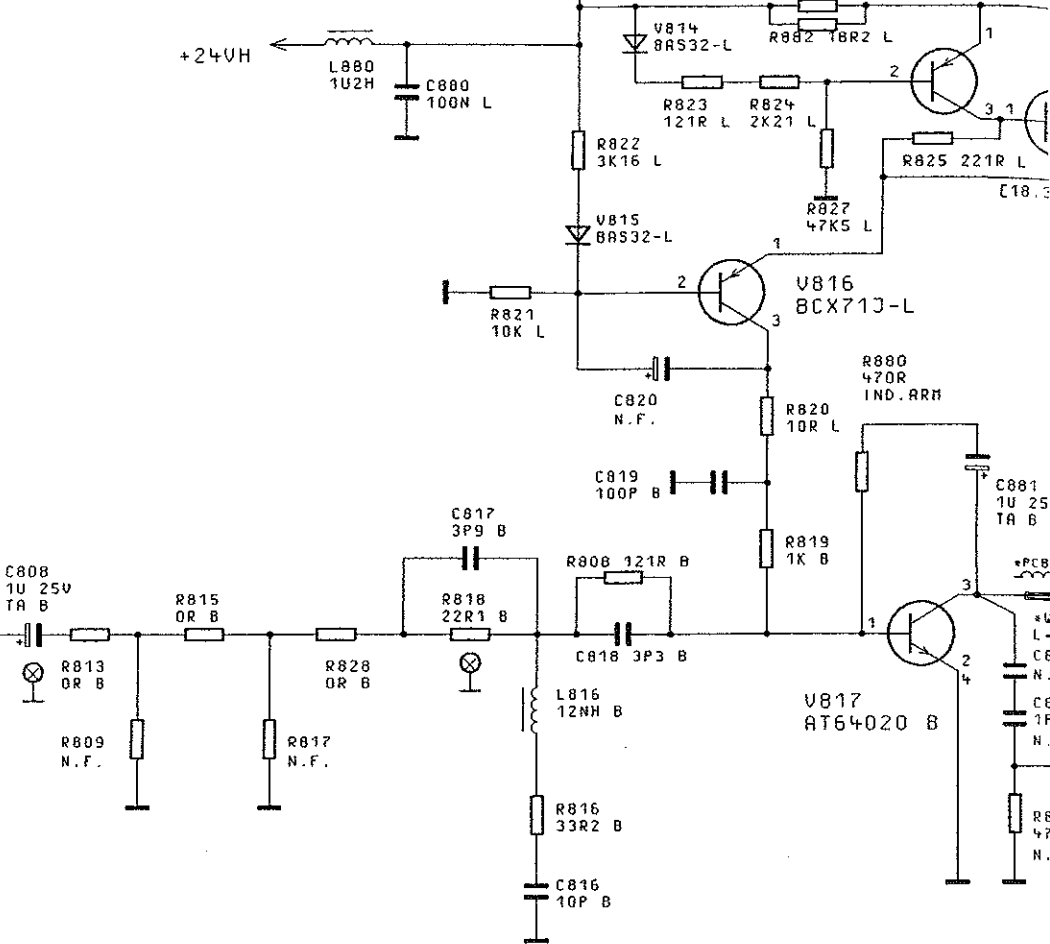
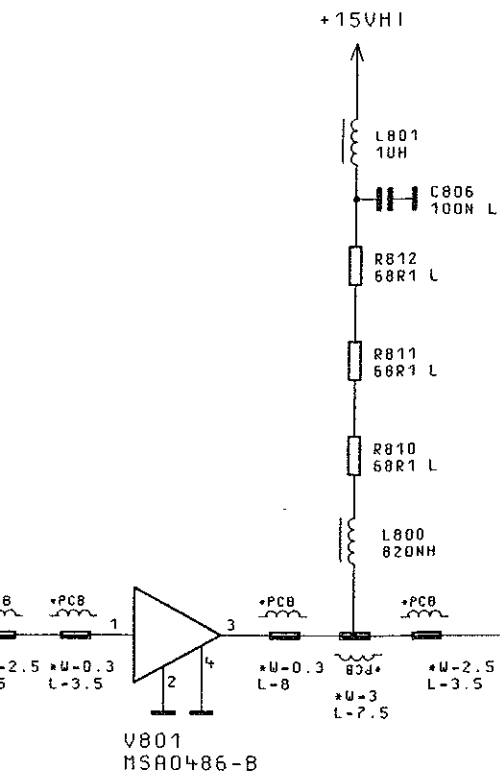

DETECTOR LINEARIZER

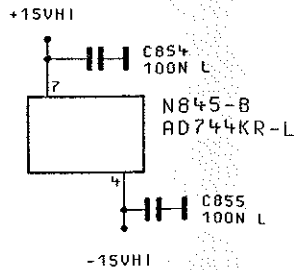
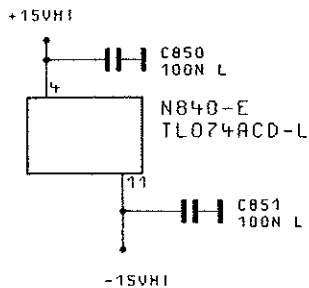
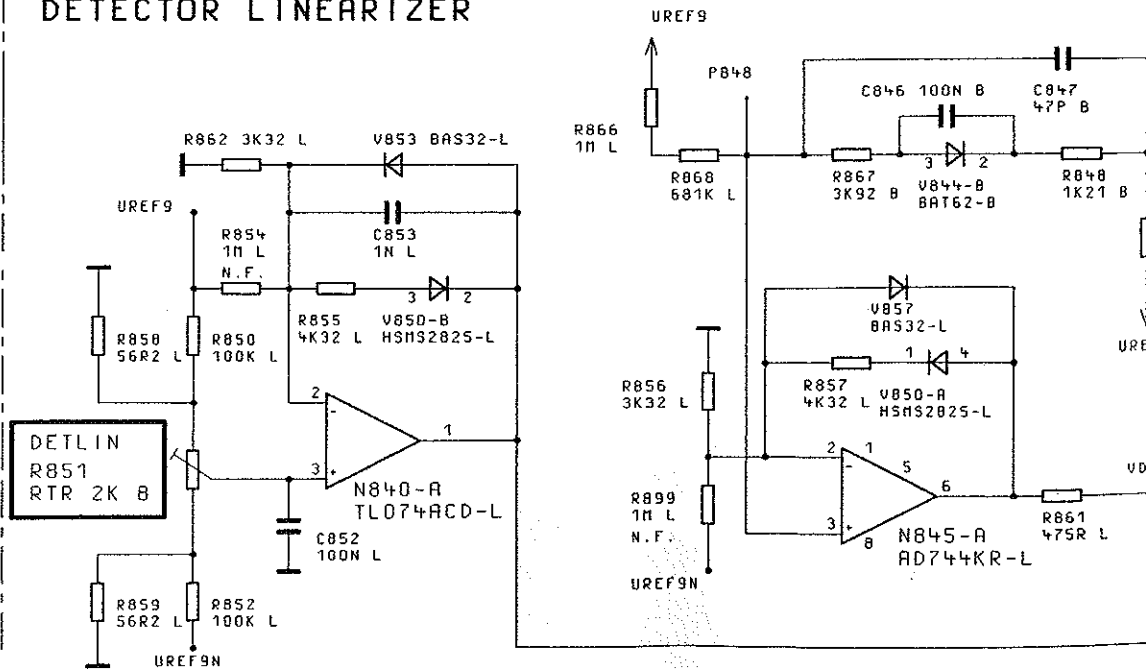

N.F. - NOT FITTED / NICHT
 *** - WITH/ MIT OPTION SBY-

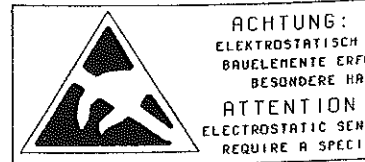

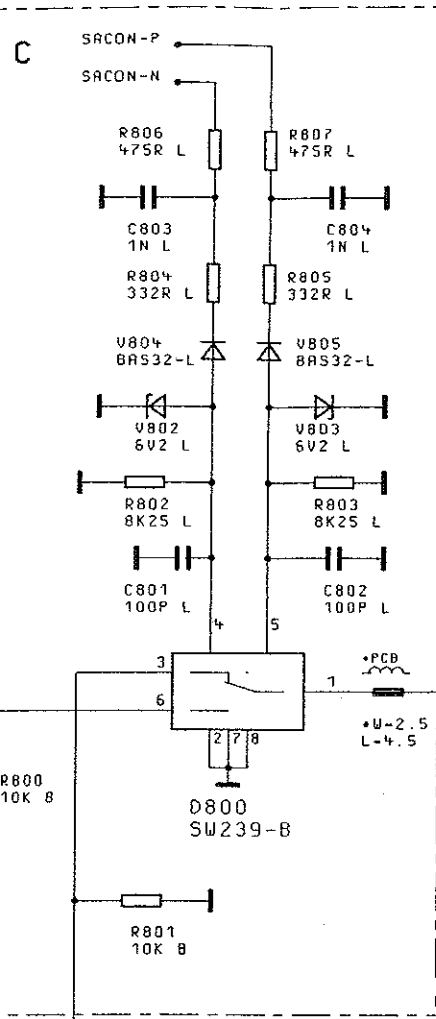

RF AMPLIFIER 11

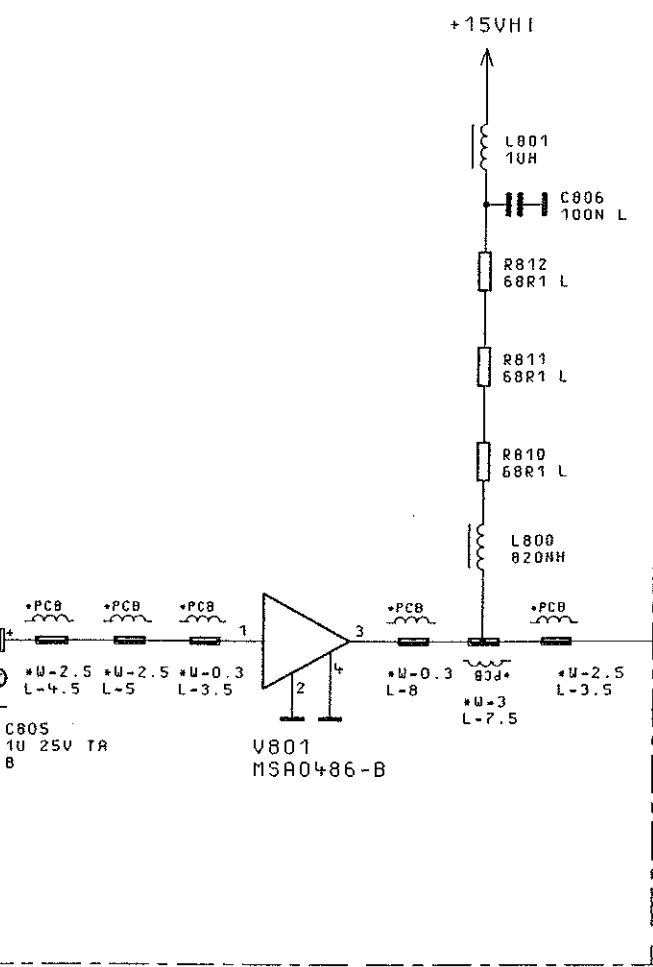

RF AMPLIFIER 12

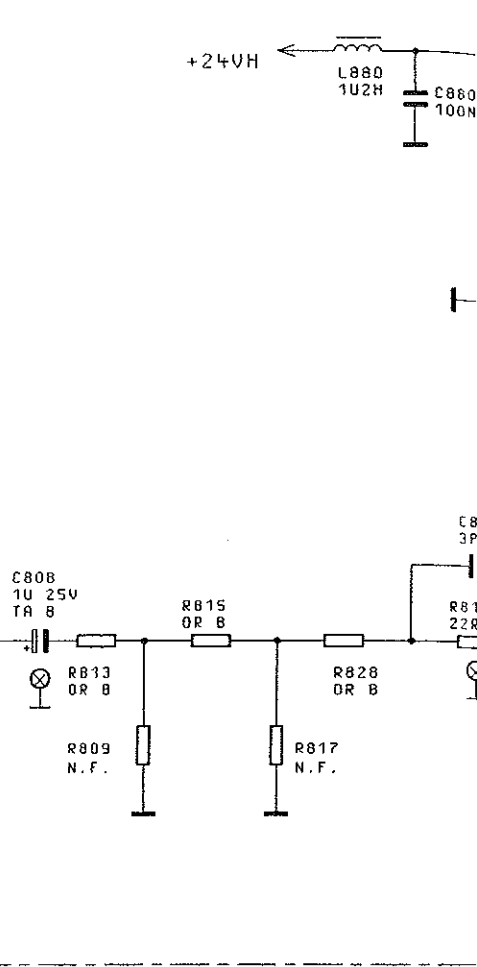

DOUBLEROUT FROM SHEET 12

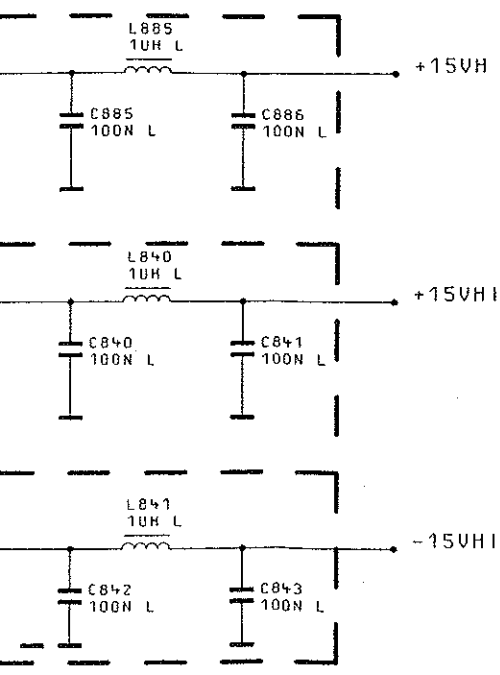

DETECTOR LINEARIZER

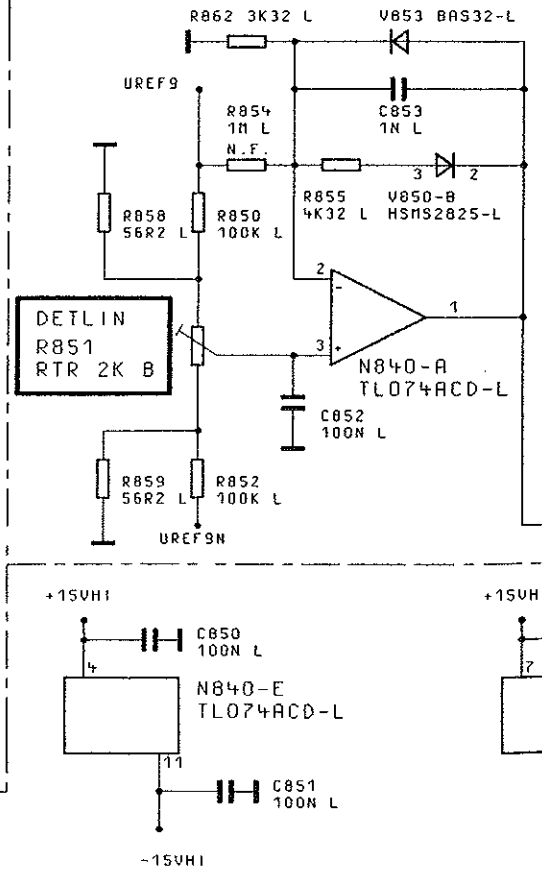

SWITCH C

RF AMPLIFIER 11

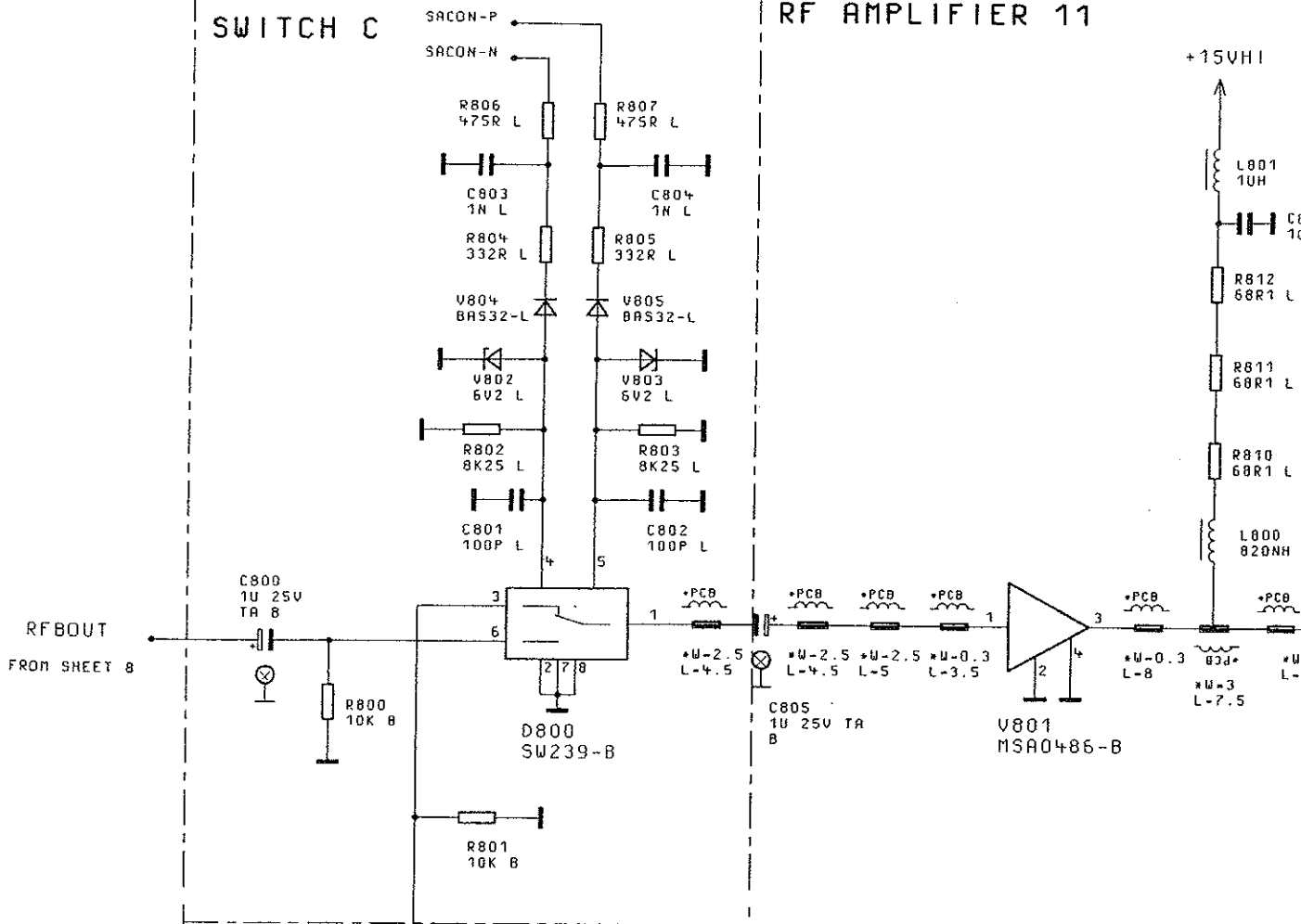

B1

DOUBLEROUT
FROM SHEET 12

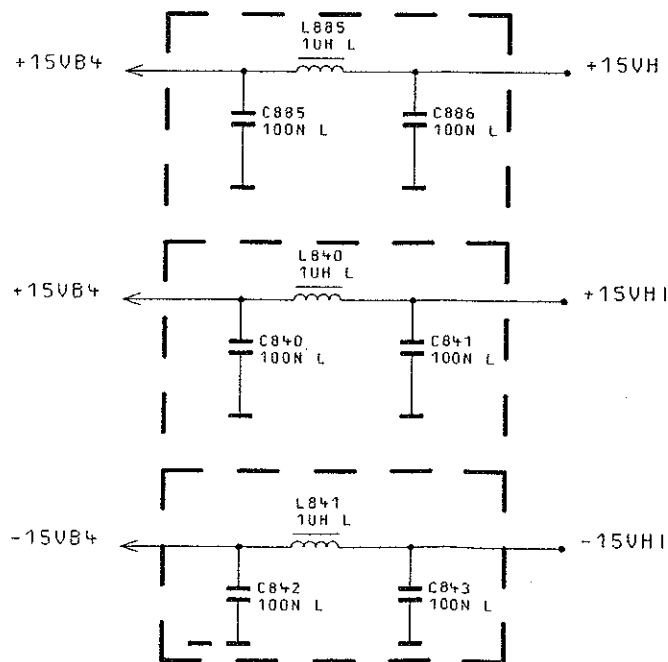

BLAHLIEN VJR UNS ALLE RECHTE VOR

BYTE 4+5

BYTE 6+7

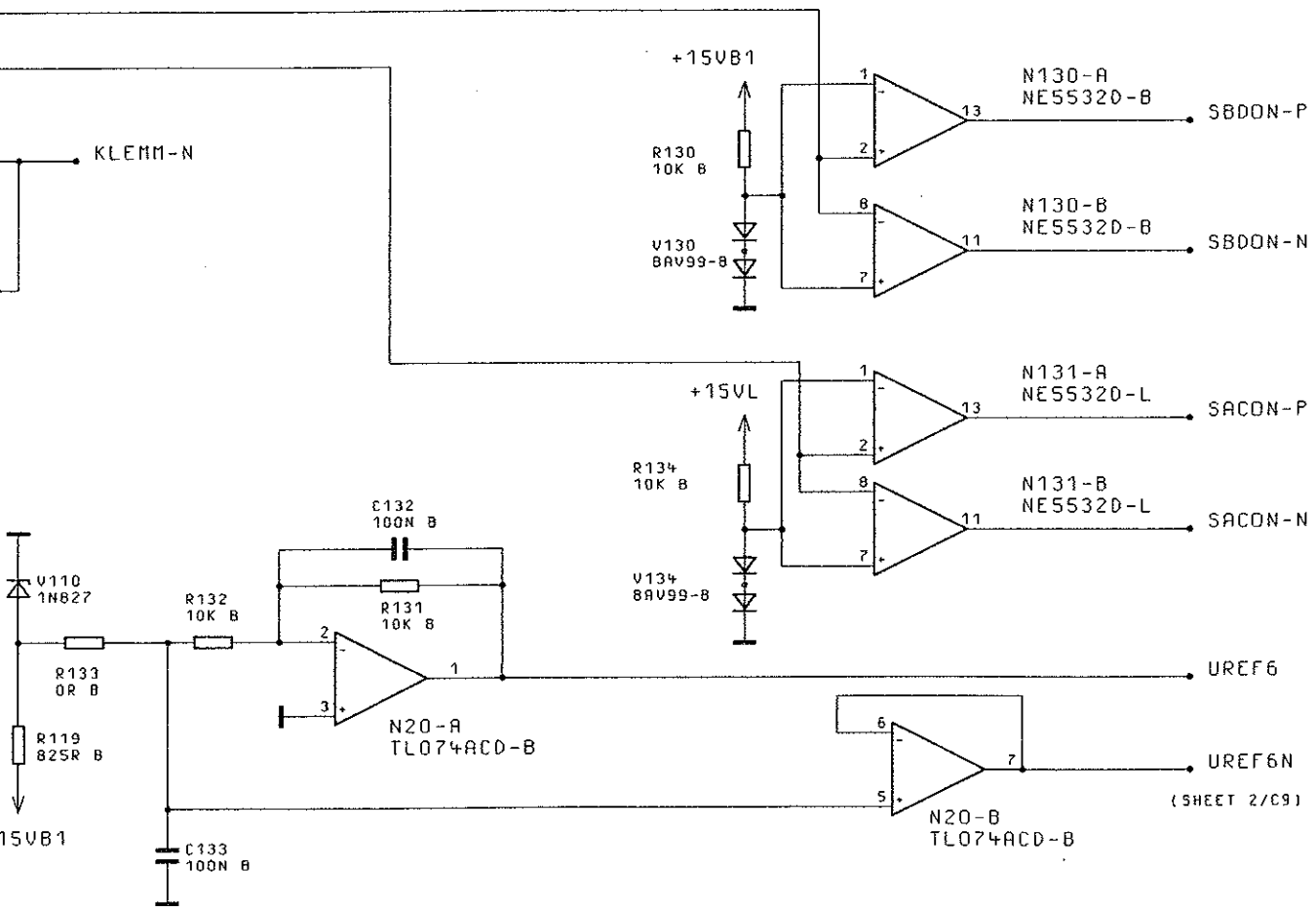
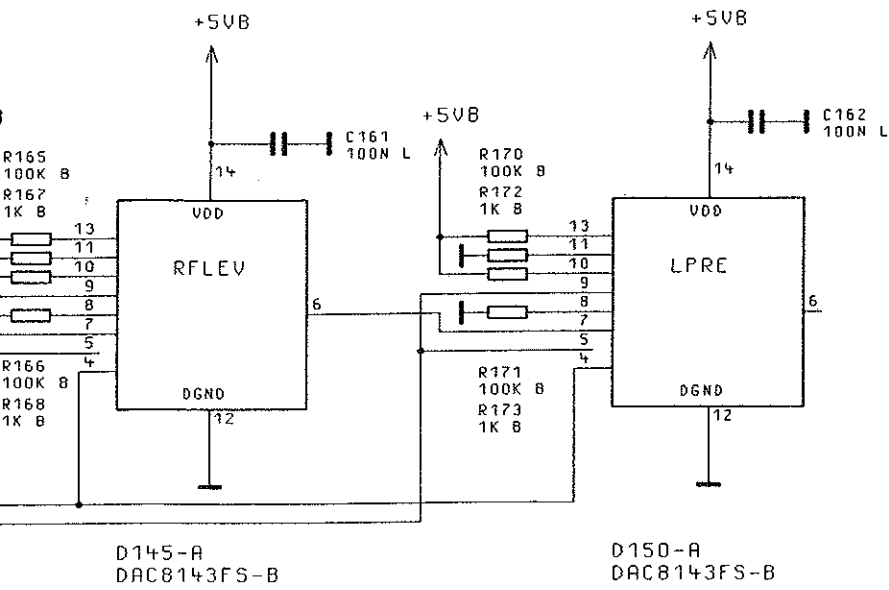



04/02		03.03.97	E I	MENP	TAG	NAME	BENENNUNG
				BEARB.		E I	AUSGANGSTEIL 2.08GHZ OUTPUT UNIT 2.08GHZ
				GEPR.			
				NORM			
				PLOTT	03.03.97		
04/01		16.12.96	E I	 ROHDE&SCHWARZ		ZEICHN.-NR.	BLATT-NR.
REND. IND.	RENDERUNGS-HITTEILUNG	DATUM	NARE			1062.7005.01S	10+
				ZU GERÄT	SMY	REG. I. V.	ERST Z.
						1062.5502	1062.5502

BYTE 3+4

BYTE 4+5

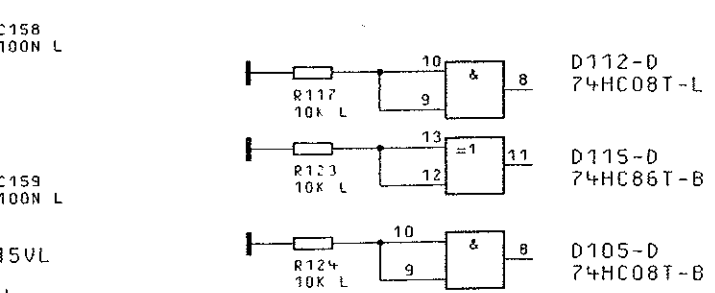
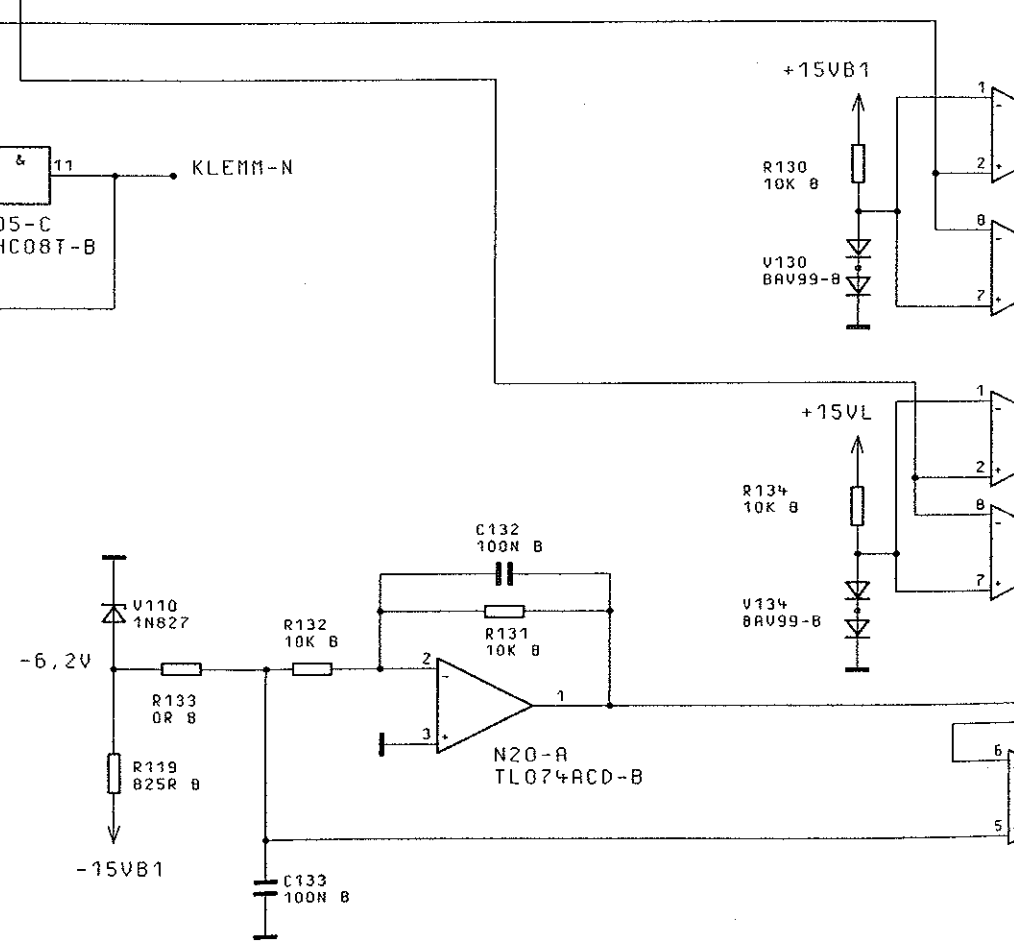
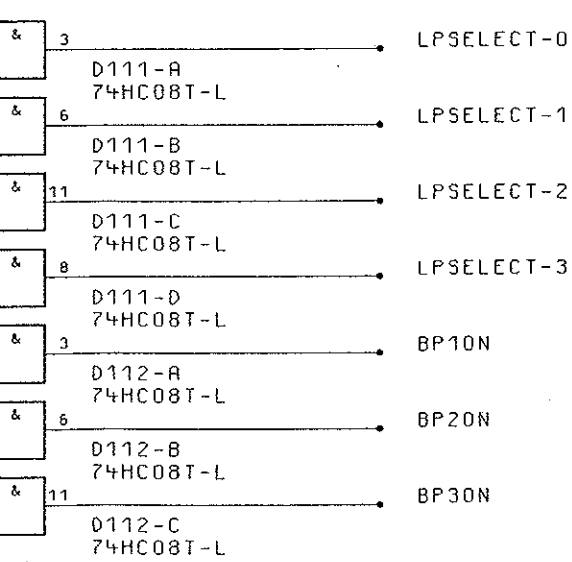
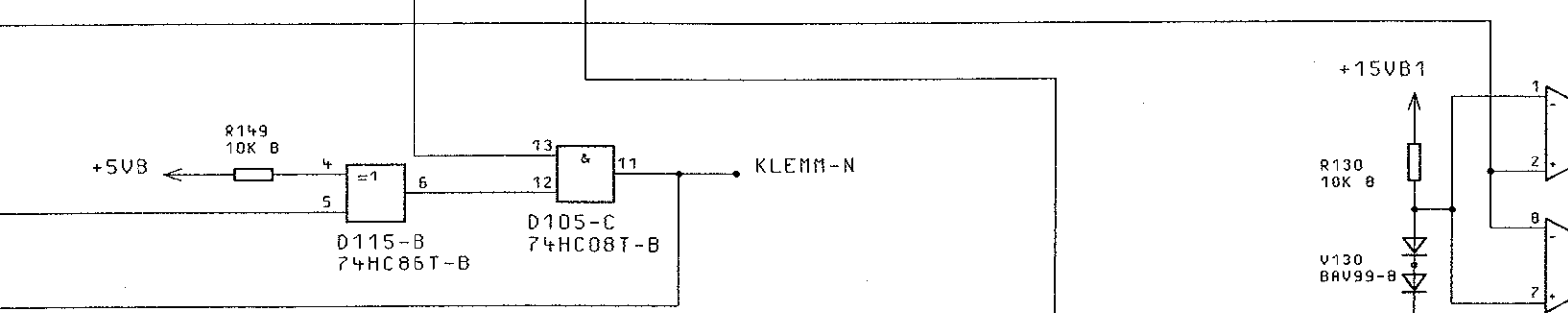
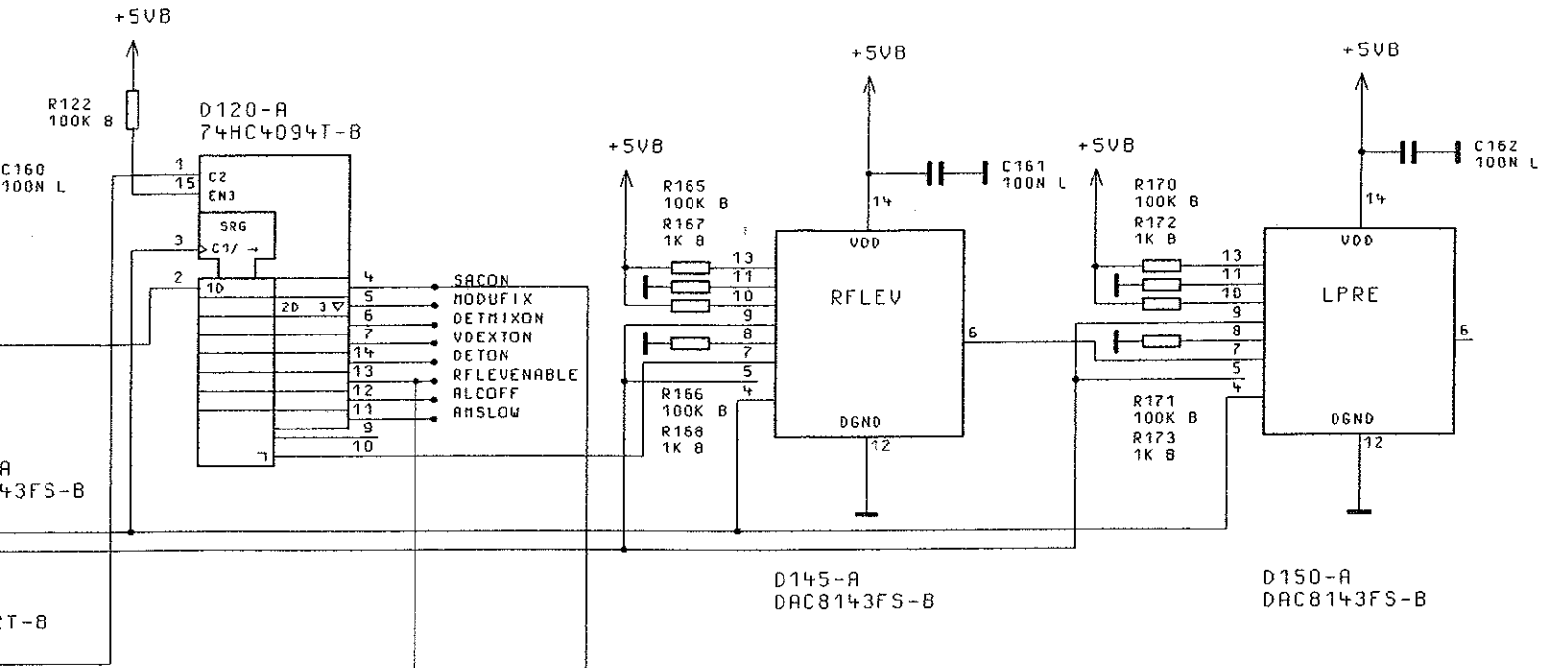
BYTE 6+7



04/02	03.03.97	E I	MENP	TAG	NAME	BEN
			BEARB.		E I	
			GEPR.			
			NORM			
			PLOTT	03.03.97		
04/01	16.12.96	E I				ZEL
REND. IND.	ÄNDERUNGS-MITTEILUNG	DATUM	NAME			REG.
				ZU GERÄT	SMY	

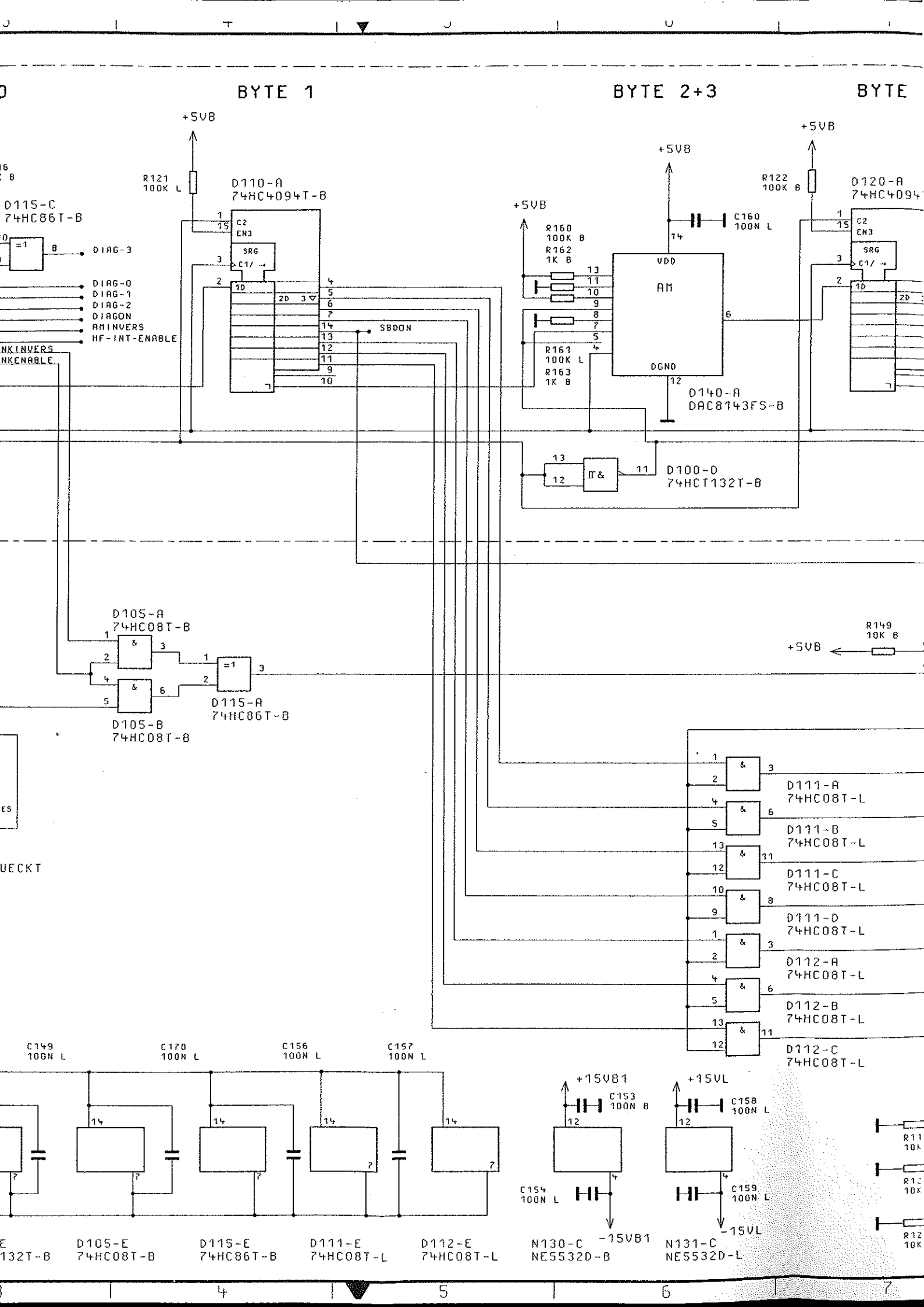

SUBADDRESS 0
BYTE 0

BYTE 1

BY

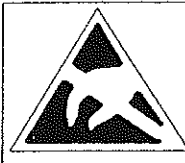
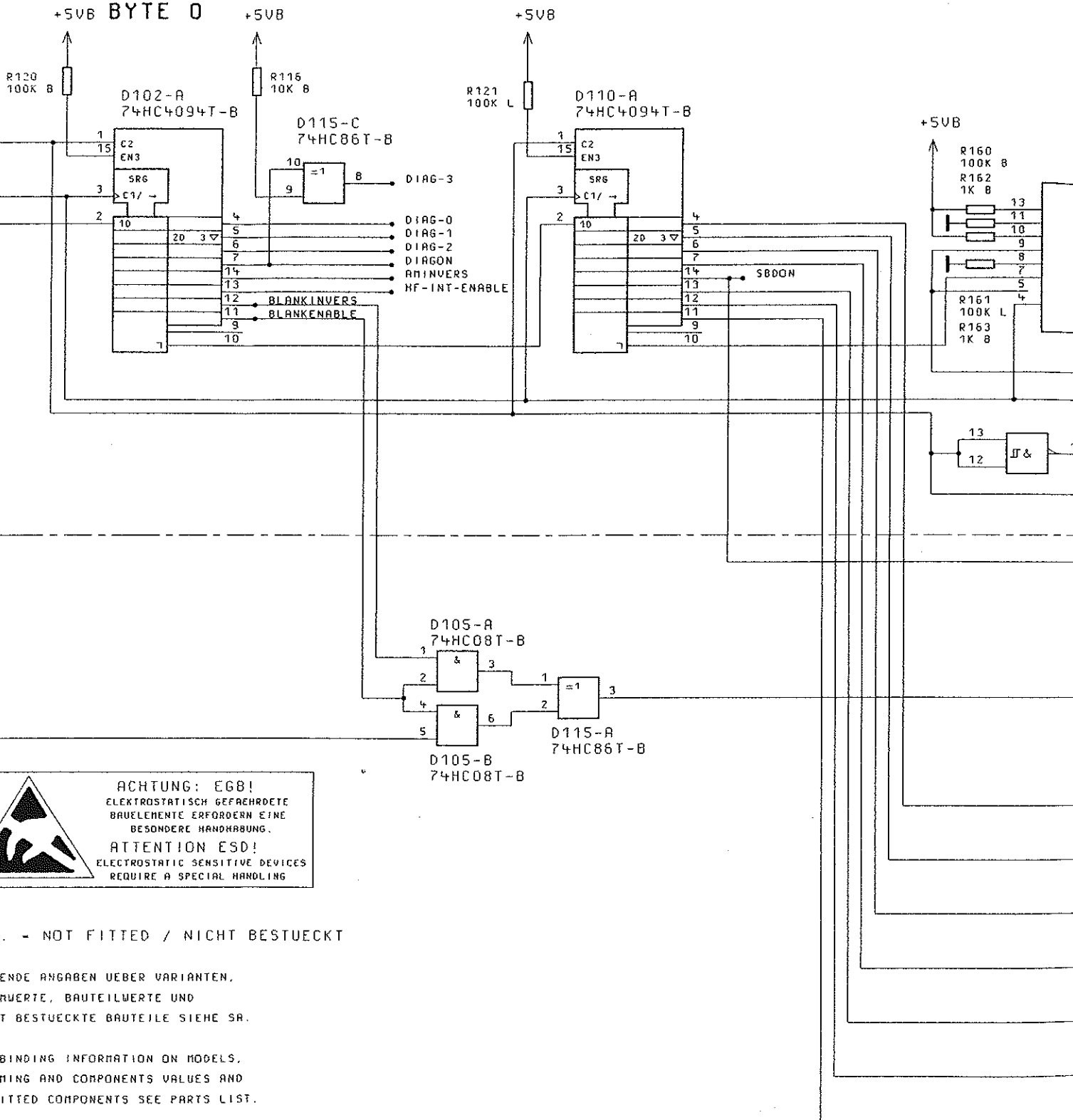

ACHTUNG: EGB!
ELEKTROSTATISCH GEFÄHRDETE
BAUELEMENTE ERFORDERN EINE
BESONDERE HANDHABUNG.
ATTENTION ESD!
ELECTROSTATIC SENSITIVE DEVICES
REQUIRE A SPECIAL HANDLING

N.F. - NOT FITTED / NICHT BESTUECKT

BINDENDE ANGABEN UEBER VARIANTEN,
TRIMMWERTE, BAUTEILWERTE UND
NICHT BESTUECKTE BAUTEILE SIEHE SR.

FOR BINDING INFORMATION ON MODELS,
TRIMMING AND COMPONENTS VALUES AND
NONFITTED COMPONENTS SEE PARTS LIST.

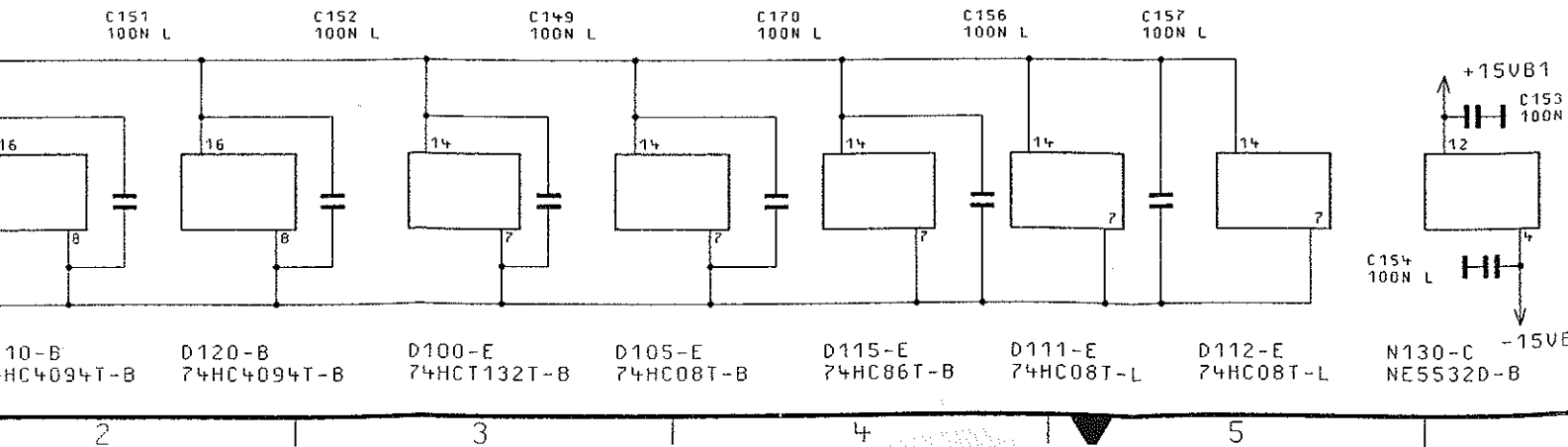

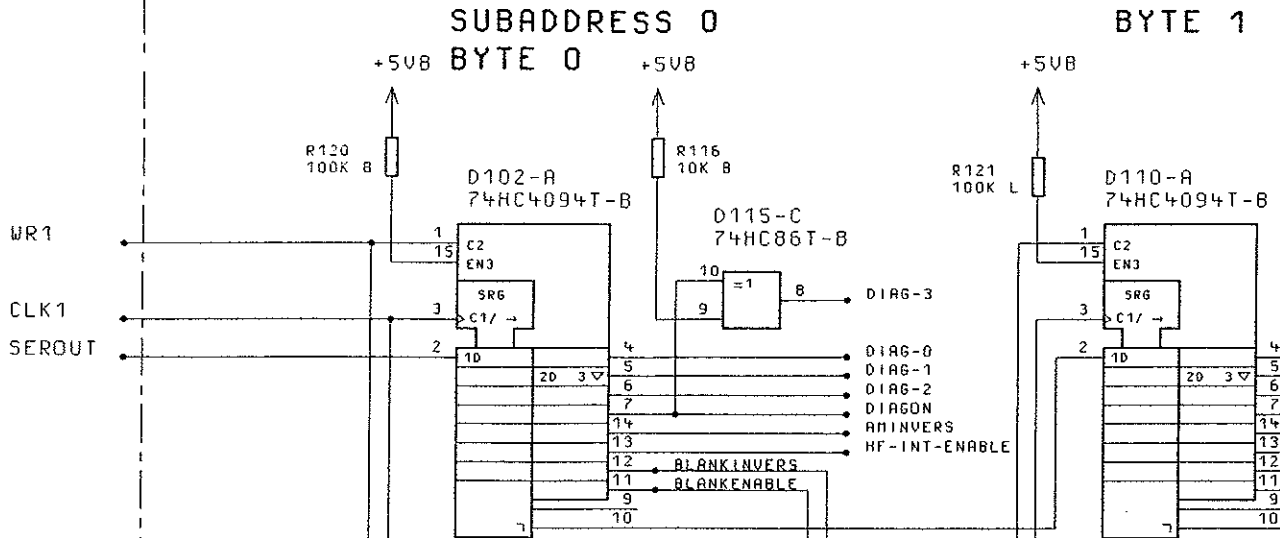

BLANK



N.F. - NOT FITTED / NICHT BESTUECKT

BINDENDE ANGABEN UEBER VARIANTEN,
TRIMMWERTE, BAUTEILWERTE UND
NICHT BESTUECKTE BAUTEILE SIEHE SA.

FOR BINDING INFORMATION ON MODELS,
TRIMMING AND COMPONENTS VALUES AND
NONFITTED COMPONENTS SEE PARTS LIST.

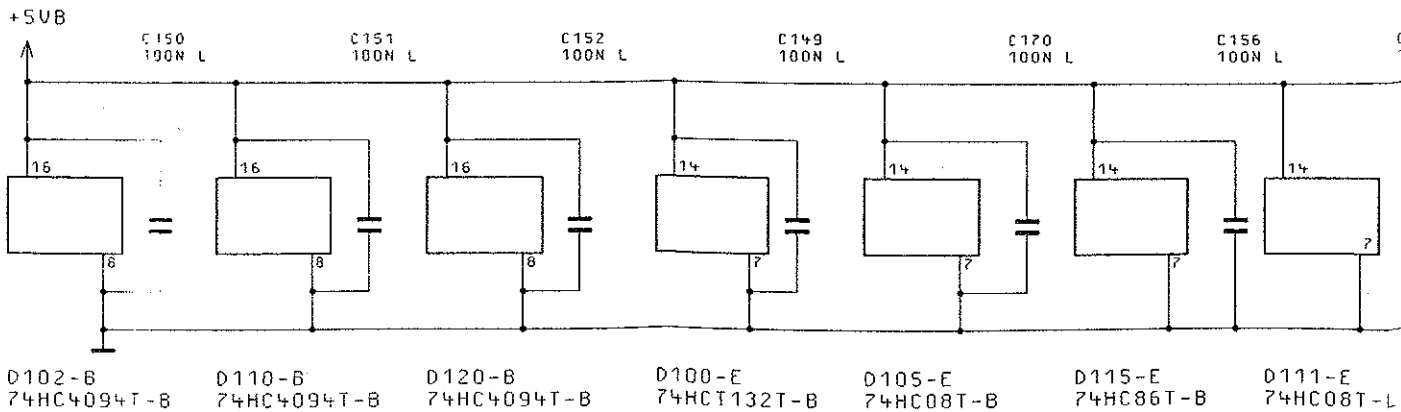

D102-B 74HC4094T-B D110-B 74HC4094T-B D120-B 74HC4094T-B D100-E 74HC132T-B D105-E 74HC08T-B D115-E 74HC86T-B D111-E 74HC08T-L

1

2

3

4

FUER DIESE UNTERLAGE
BEHALTEN WIR UNS ALLE RECHTE VOR

ZEICHN.-NR.

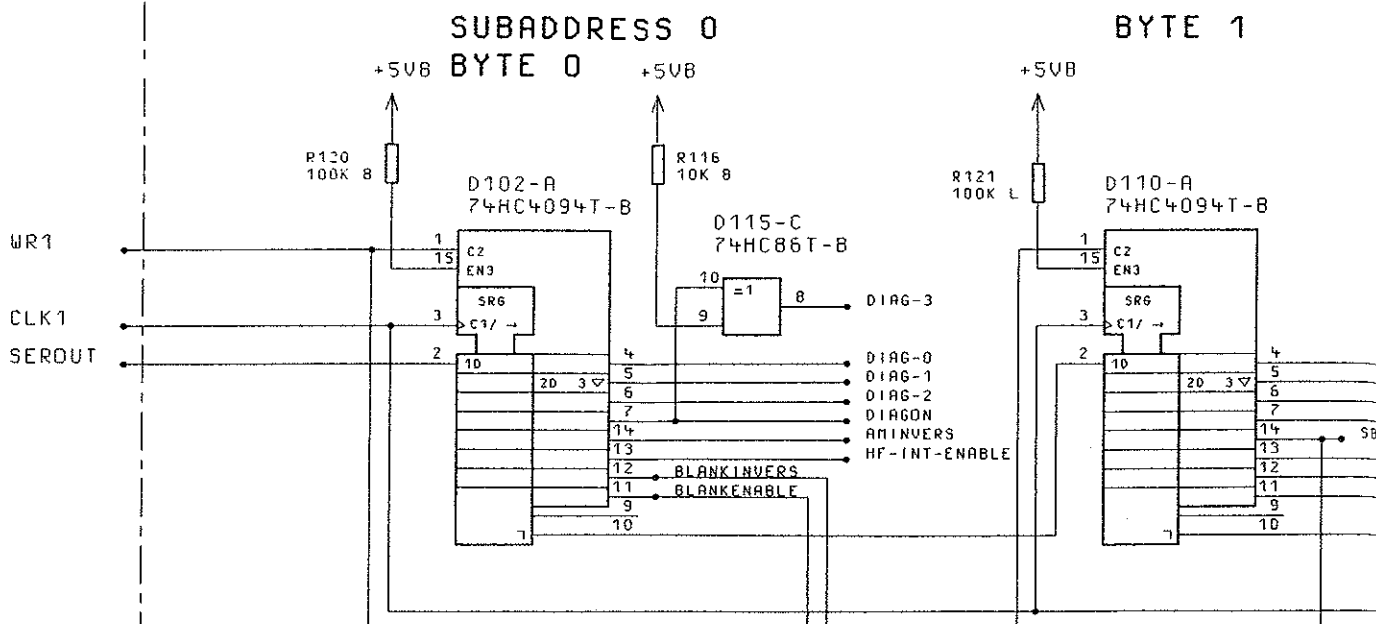



ACHTUNG: EGB!
 ELEKTROSTATISCH GEFÄHRDETE
 BAUELEMENTE ERFORDERN EINE
 BESONDERE HANDHABUNG.
ATTENTION ESD!
 ELECTROSTATIC SENSITIVE DEVICES
 REQUIRE A SPECIAL HANDLING

N.F. - NOT FITTED / NICHT BESTUECKT

BINDENDE ANGABEN UEBER VARIANTEN,
 TRIMMWERTE, BAUTEILWERTE UND
 NICHT BESTUECKTE BAUTEILE SIEHE SA.

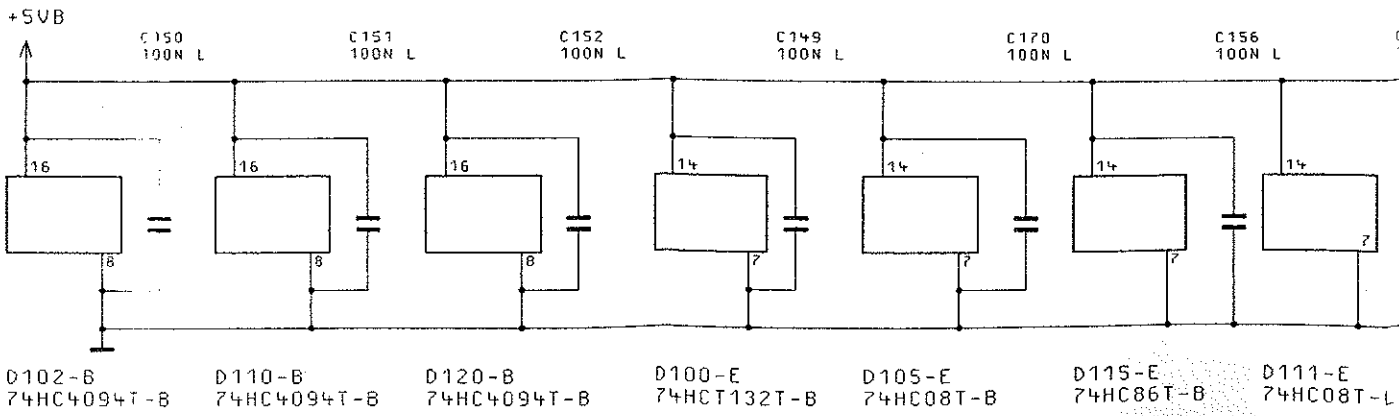
FOR BINDING INFORMATION ON MODELS,
 TRIMMING AND COMPONENTS VALUES AND
 NONFITTED COMPONENTS SEE PARTS LIST.



FUER DIESE UNTERLAGE
 BEHALTEN WIR UNS ALLE RECHTE VOR

ZEICHN.-NR.

AM-MODULATOR

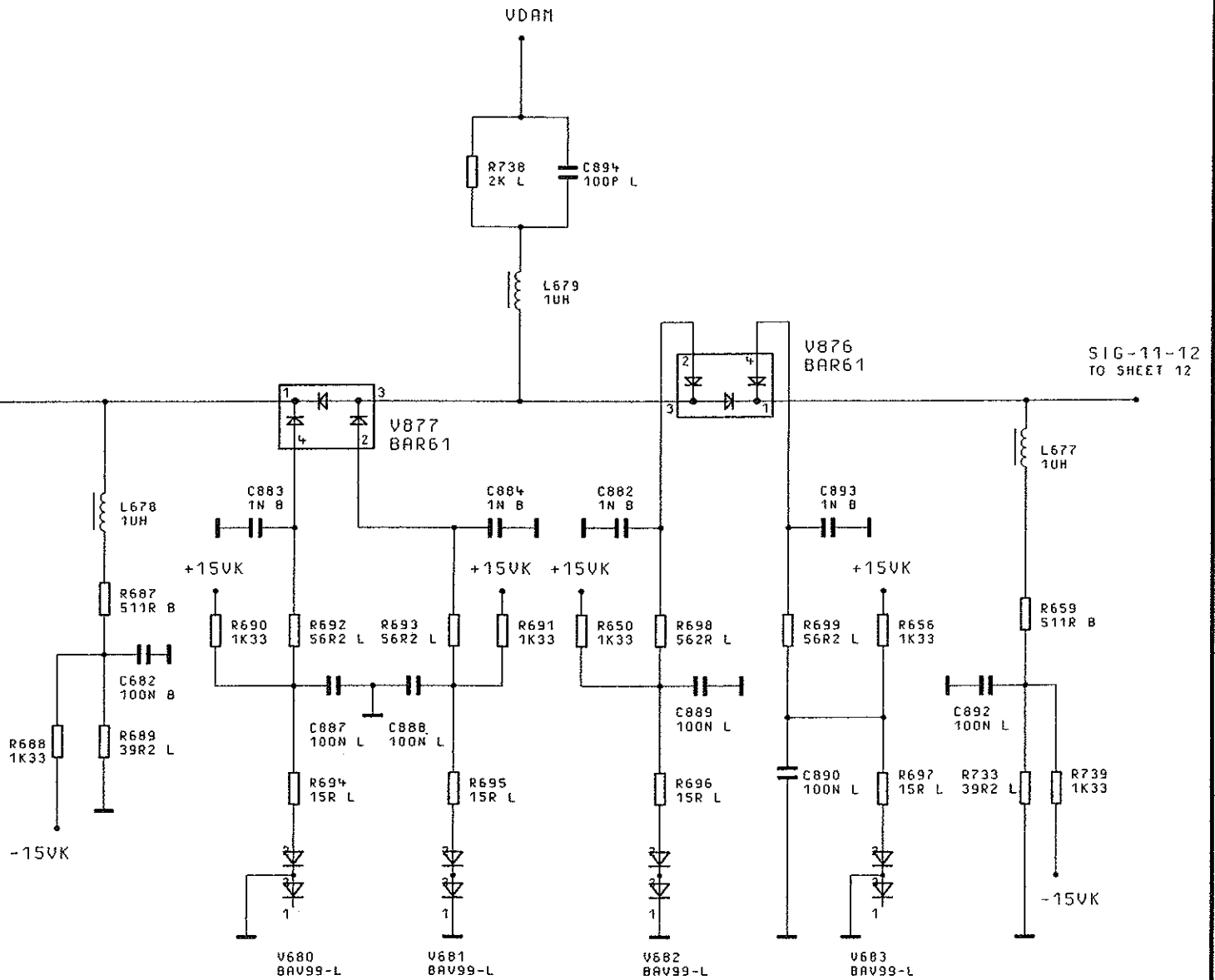

BINDENDE ANGABEN UEBER VARIANTEN,
TRIMMWERTE, BAUTEILWERTE UND
NICHT BESTUECKTE BAUTEILE SIEHE SA.

FOR BINDING INFORMATION ON MODELS,
TRIMMING AND COMPONENTS VALUES AND
NONFITTED COMPONENTS SEE PARTS LIST.

04/02	03.03.97	E I	MENP	TAG	NAME	BENENNUNG
			BEARB.		E I	AUSGANGSTEIL 2.08GHZ OUTPUT UNIT 2.08GHZ
			GEPR.			
			NORM			
			PLOTT	03.03.97		
04/01	16.12.96	E I	 ROHDE&SCHWARZ			ZEICHN.-NR.
AEND. IND.	AENDERUNG- MITTEILUNG	DATUM				NAME
			ZU GERÄT	SMY	REG.-I.V.	1062.5502
					ERSTE Z.	1062.5502

R 8

UDOUBLER

AM-MODULATOR

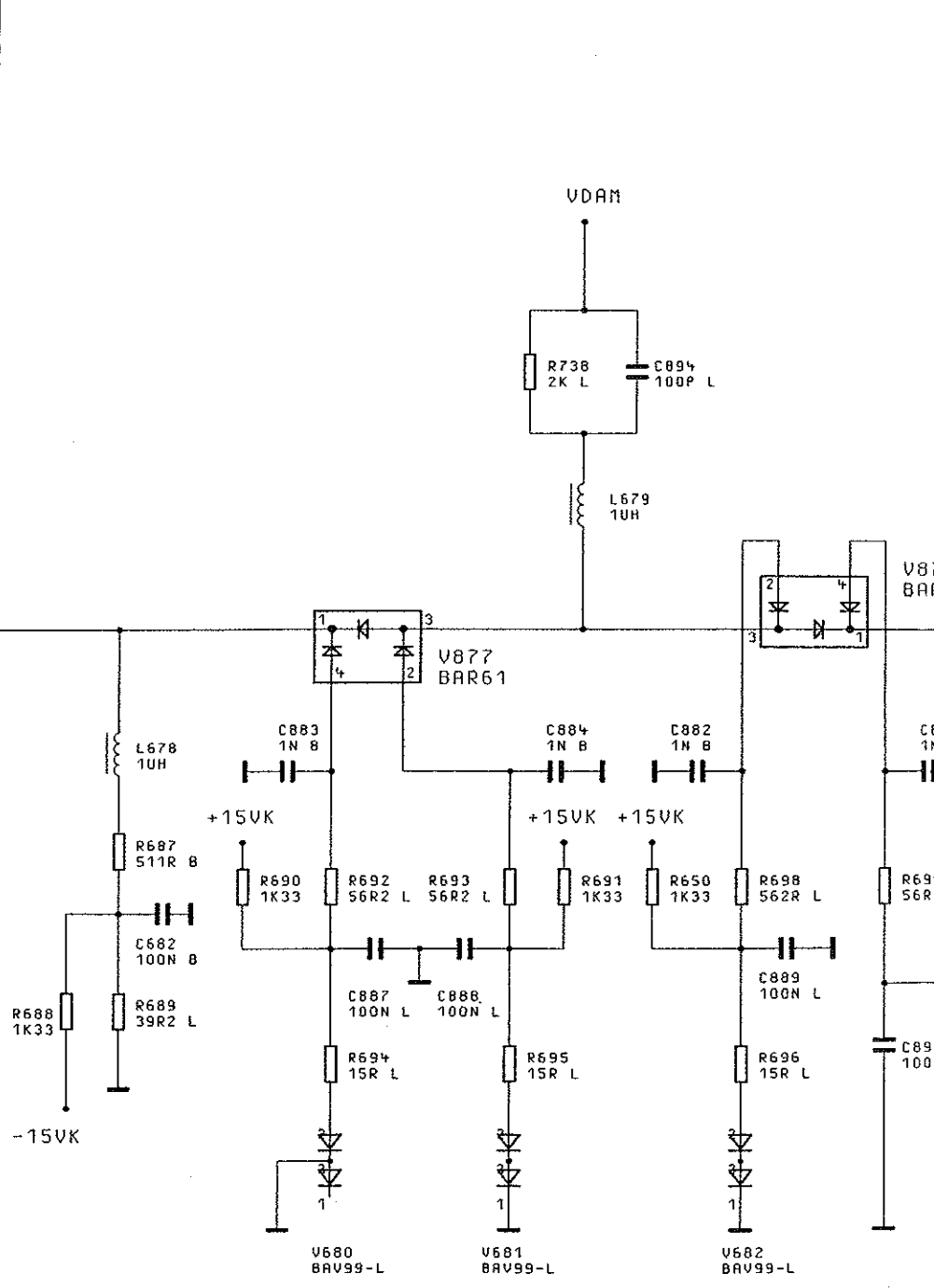
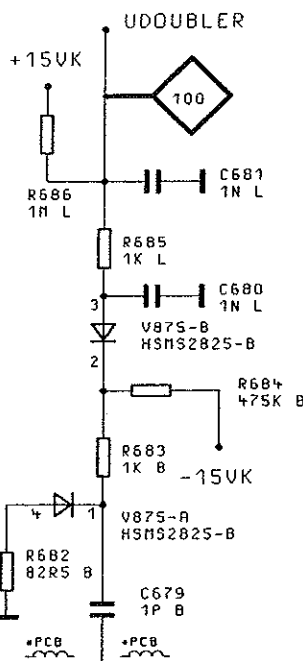
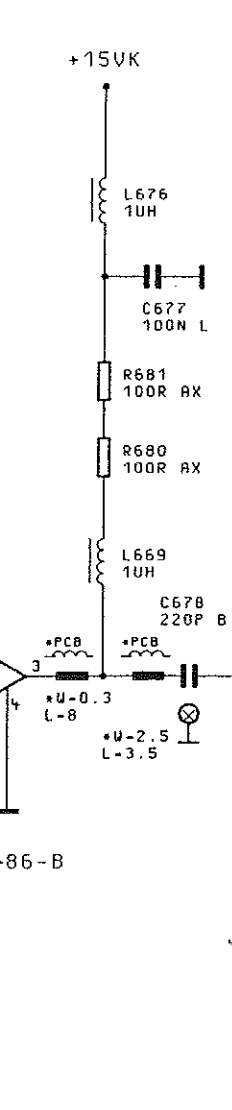

N.F. - NOT FITTED / NICHT BESTUECKT

BINDENDE ANGABEN UEBER VARIANTEN, TRIMMWERTE, BAUTEILWERTE UND NICHT BESTUECKTE BAUTEILE SIEHE SA.

FOR BINDING INFORMATION ON MODELS, TRIMMING AND COMPONENTS VALUES AND NONFITTED COMPONENTS SEE PARTS LIST.

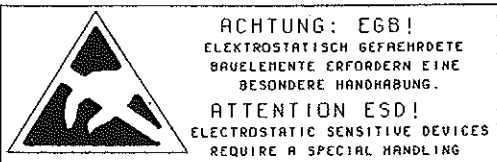

04/02	03.03.97	E I	MENP	TRG	NAME	BENENNUNG
			BEARB.		E I	AUSGANG
			GEPR.			OUTPUT UN
			NORN			
			PLOTT	03.03.97		
04/02	16.12.96	E I				ZEICHN.-NR.
REND.	RENDERUNGS-	DATUM	NAME			10
IND.	MITTEILUNG					REG. I.V.
				ZU GERÄT	SMY	1062.5

RF AMPLIFIER 8

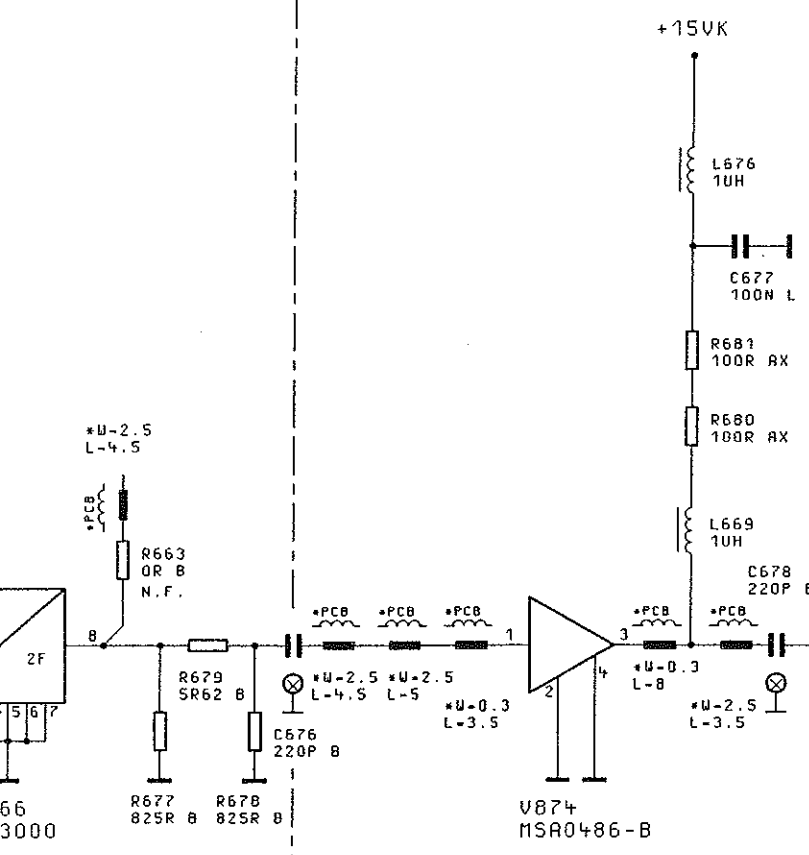

UDOUBLER

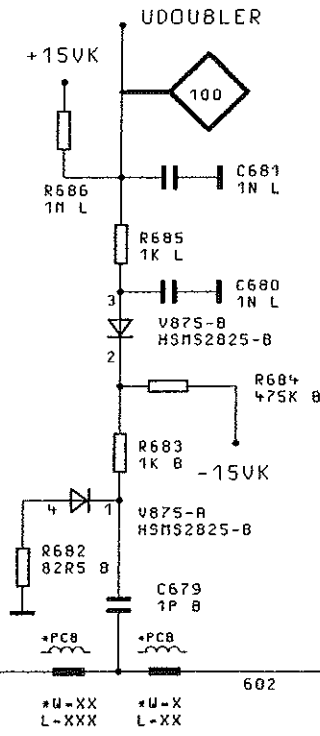

AM-MODULATOR

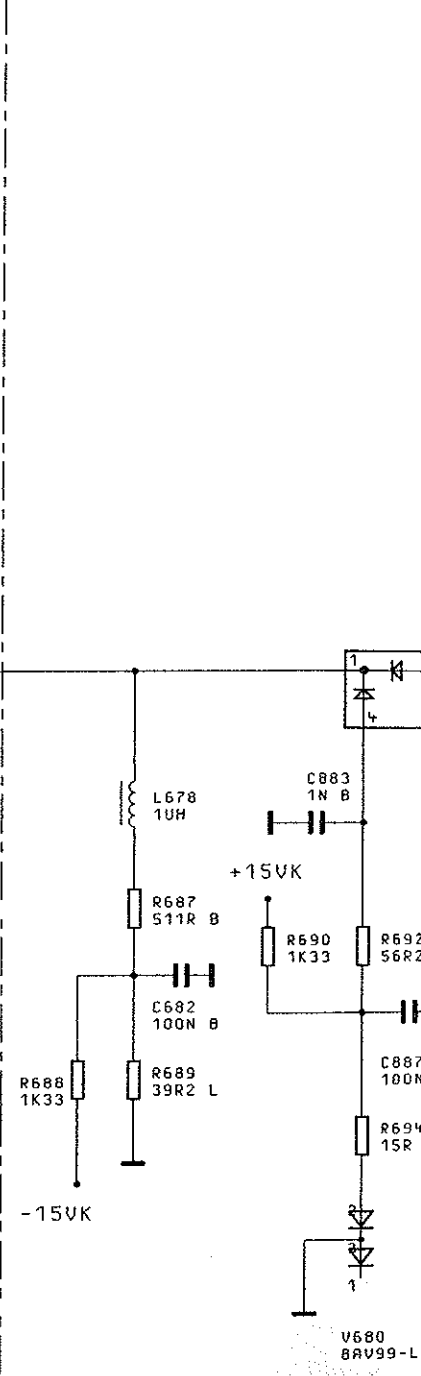

N.F. - NOT FITTED / NICHT BESTUECKT

BINDENDE ANGABEN UEBER VARIANTEN TRIMMWERTE, BAUTEILWERTE UND NICHT BESTUECKTE BAUTEILE SIEHE



ACHTUNG: EGB!
ELEKTROSTATISCH GEFAHRDETE
BAUELEMENTE ERFORDERN EINE
BESONDERE HANDHABUNG.

ATTENTION ESD!
ELECTROSTATIC SENSITIVE DEVICES
REQUIRE A SPECIAL HANDLING

04/02	03.03.97
04/01	16.12.96
REND. IND.	DATUM

ER 7

DOUBLER

RF AMPLIFIER 8

UDOUBLE

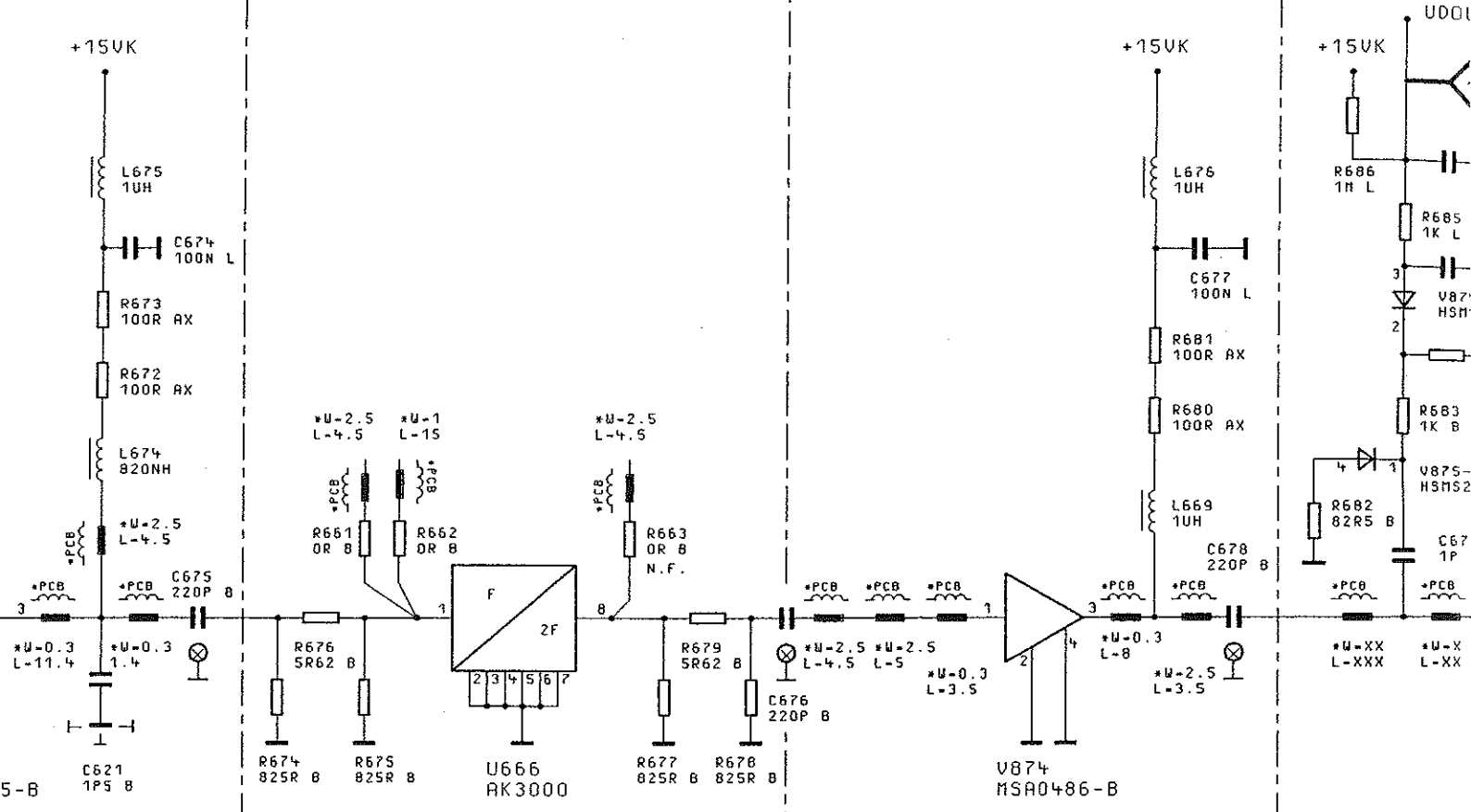

N.F. - NOT FITTED / NICHT BEST

ACHTUNG: EGB!
ELEKTROSTATISCH GEFÄHRD
BAUELEMENTE ERFOEDERN E
BESONDERE HANDHABUNG
ATTENTION ESD!
ELECTROSTATIC SENSITIVE D
REQUIRE A SPECIAL HANDL

AMPLIFIER 6

RF AMPLIFIER 7

DOUBLER

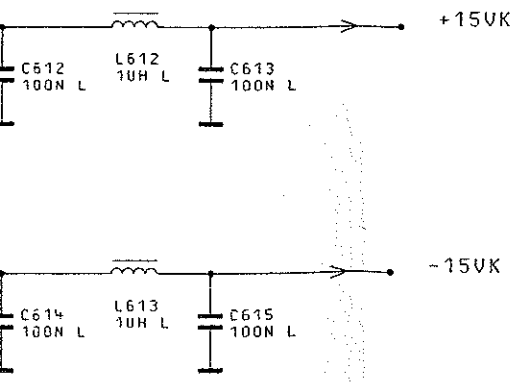
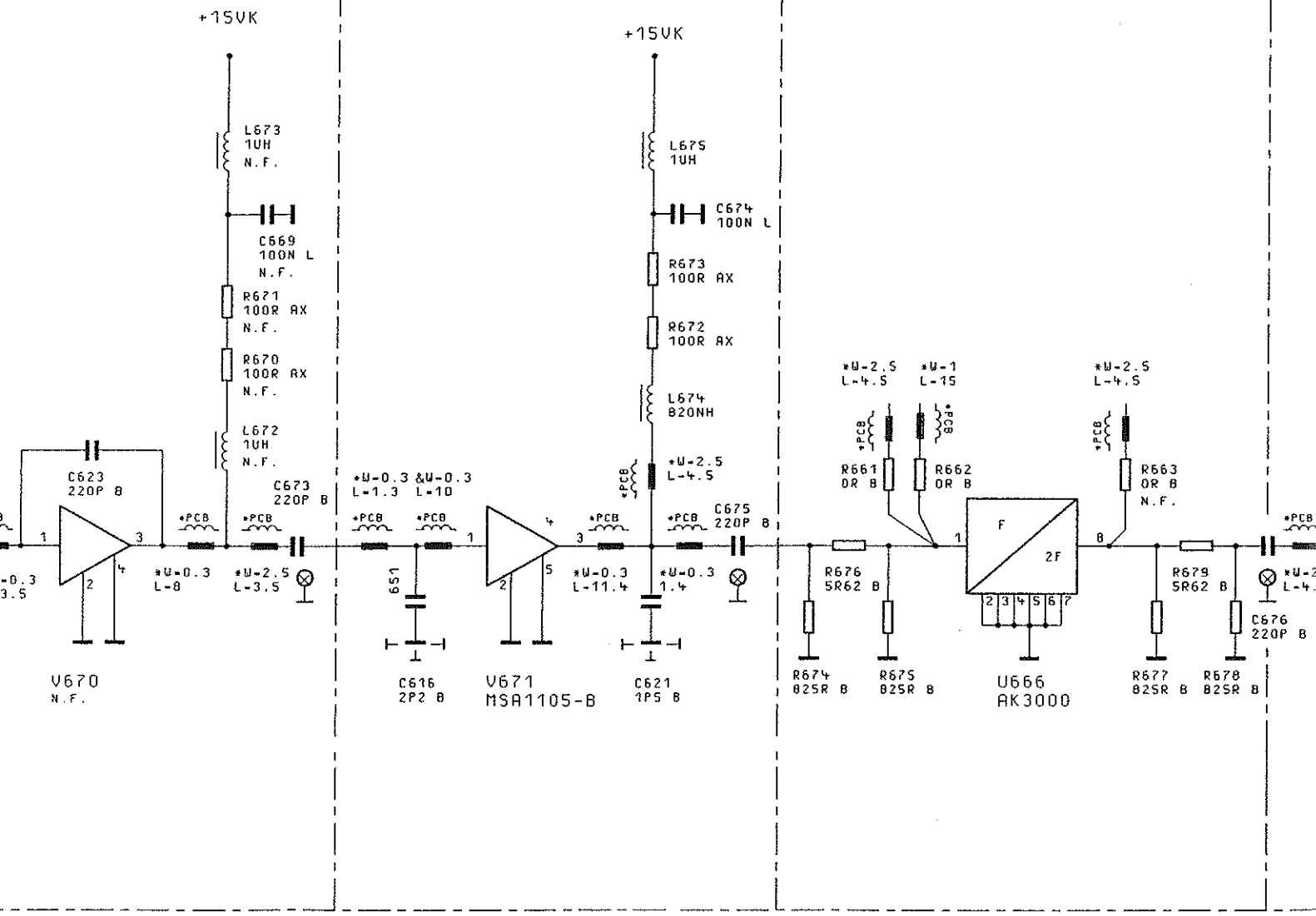

BEHALTEN WIR UNS ALLE RECHTE VOR

RF AMPLIFIER 6

RF AMPLIFIER 7

DOUBLE

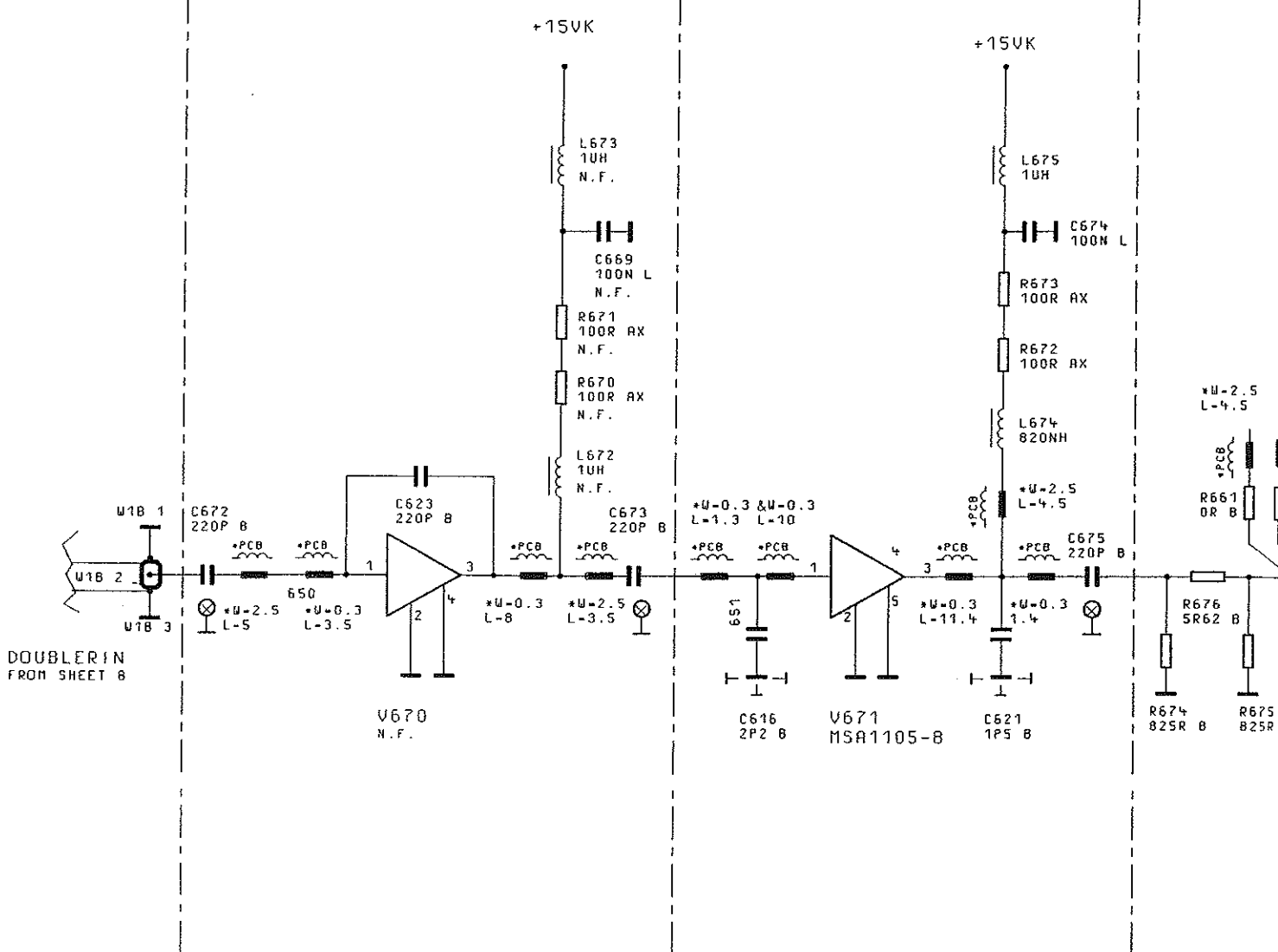

DOUBLERIN FROM SHEET 8

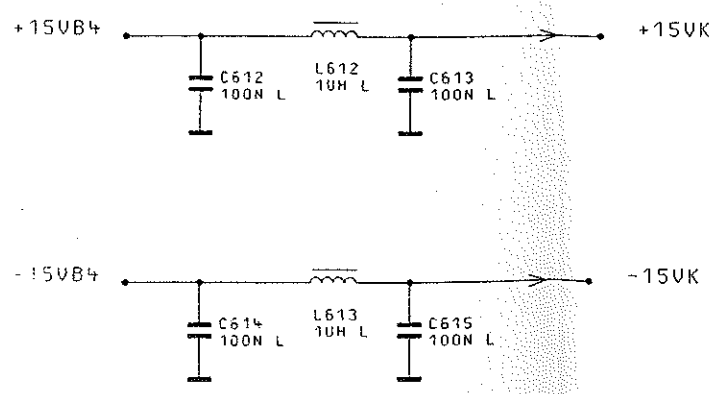

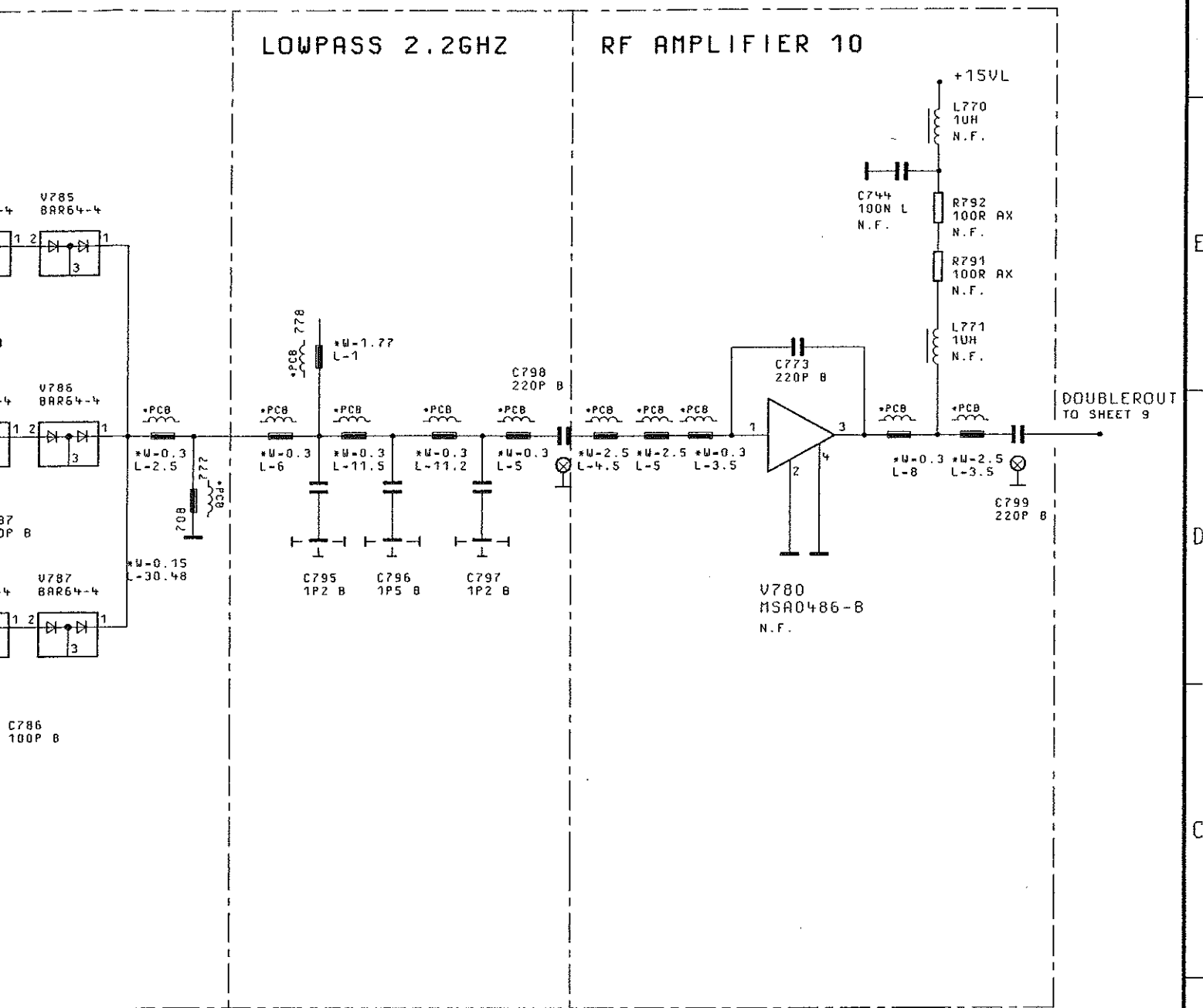

N.F. - NOT FITTED / NICHT BESTUECKT

BINDENDE ANGABEN UEBER VARIANTEN, TRIMMWERTE, BAUTEILWERTE UND NICHT BESTUECKTE BAUTEILE SIEHE SA.

FOR BINDING INFORMATION ON MODELS, TRIMMING AND COMPONENTS VALUES AND NONFITTED COMPONENTS SEE PARTS LIST.

04/02		03.03.97	E I	MENP	TAG	NAME	BEZEICHNUNG
				BEARB.		E I	AUSGANGSTEIL 2.08GHZ OUTPUT UNIT 2.08GHZ
				GEPR.			
				NDRN			
				PLOTT	03.03.97		
04/01		16.12.96	E I			ZEICHN.-NR.	BLATT-NR.
REND. IND.	RENDERUNGS-MITTEILUNG	DATUM	NAME	ROHDE&SCHWARZ		1062.7005.01S	12+
			ZU GERÄT	SMY	REG. I. V.	1062.550Z	ERSTE Z.
						1062.550Z	

LOWPASS 2.2GHZ

RF AMPLIFIER

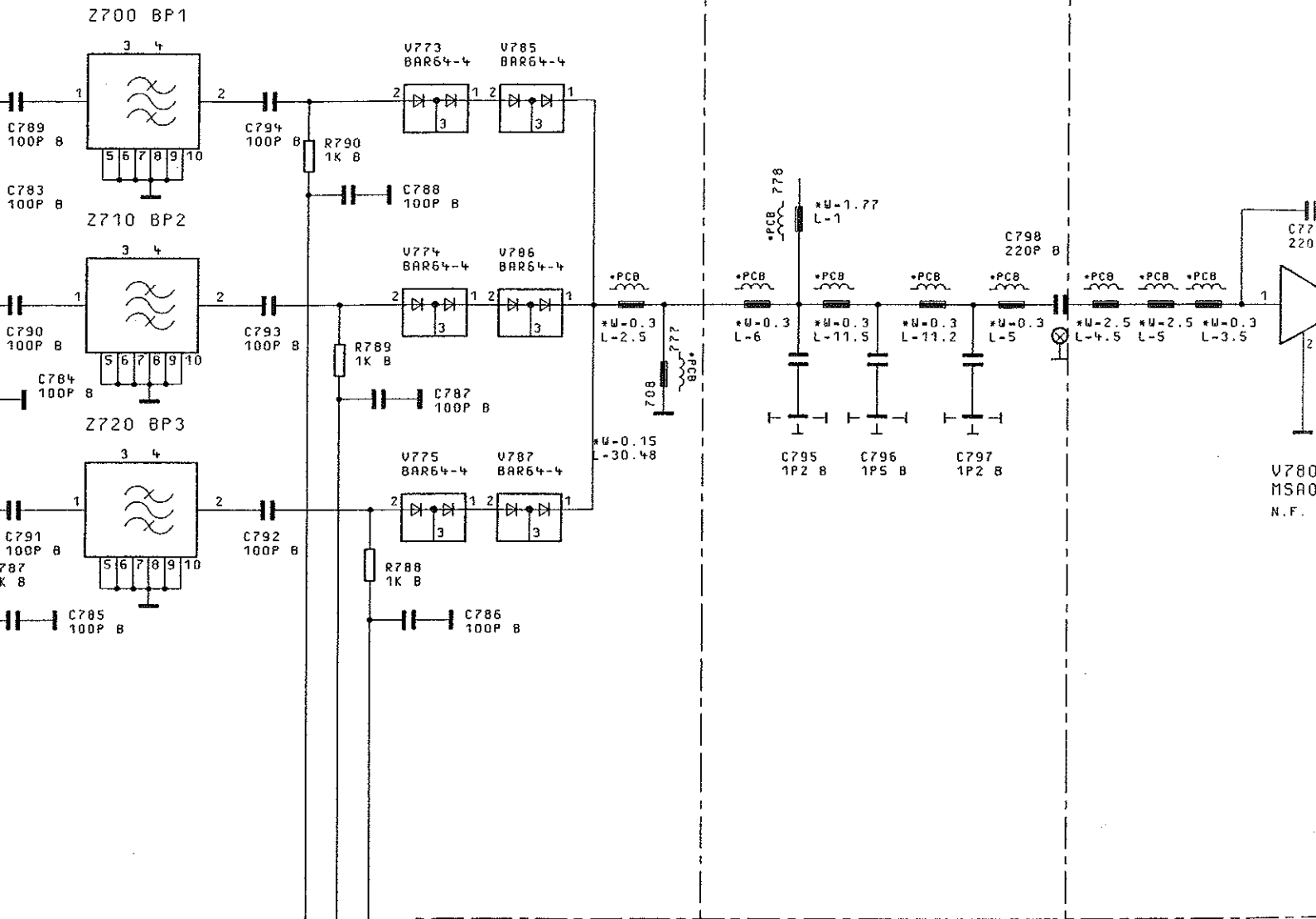

N.F. - NOT FITTED / NICHT BESTUECKT

BINDENDE ANGABEN UEBER VARIANTEN,
TRIMMWERTE, BAUTEILWERTE UND
NICHT BESTUECKTE BAUTEILE SIEHE SA.

FOR BINDING INFORMATION ON MODELS,
TRIMMING AND COMPONENTS VALUES AND
NONFITTED COMPONENTS SEE PARTS LIST

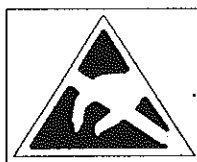

ACHTUNG: ESB!
ELEKTROSTATISCH GEFAHRDETE
BAUELEMENTE ERFORDERN EINE
BESONDERE HANDHABUNG.
ATTENTION ESD!
ELECTROSTATIC SENSITIVE DEVICES
REQUIRE A SPECIAL HANDLING

04/02	03.03.97	E I	MENP	TAG	NAME	BENENNUNG
			BEARB.		E I	AUSGABE OUTPUT
			GEPR.			
			NORM			
			PLOTT	03.03.97		
04/01	16.12.96	E I				ZEICHN.-NR.
ÄND. IND.	ÄNDERUNGS- MITTEILUNG	DATUM	NAME	ROHDE&SCHWARZ		1
			ZU GERÄT	SMY	REG. I. V.	106

TCHED BANDPASS FILTERS

LOWPA

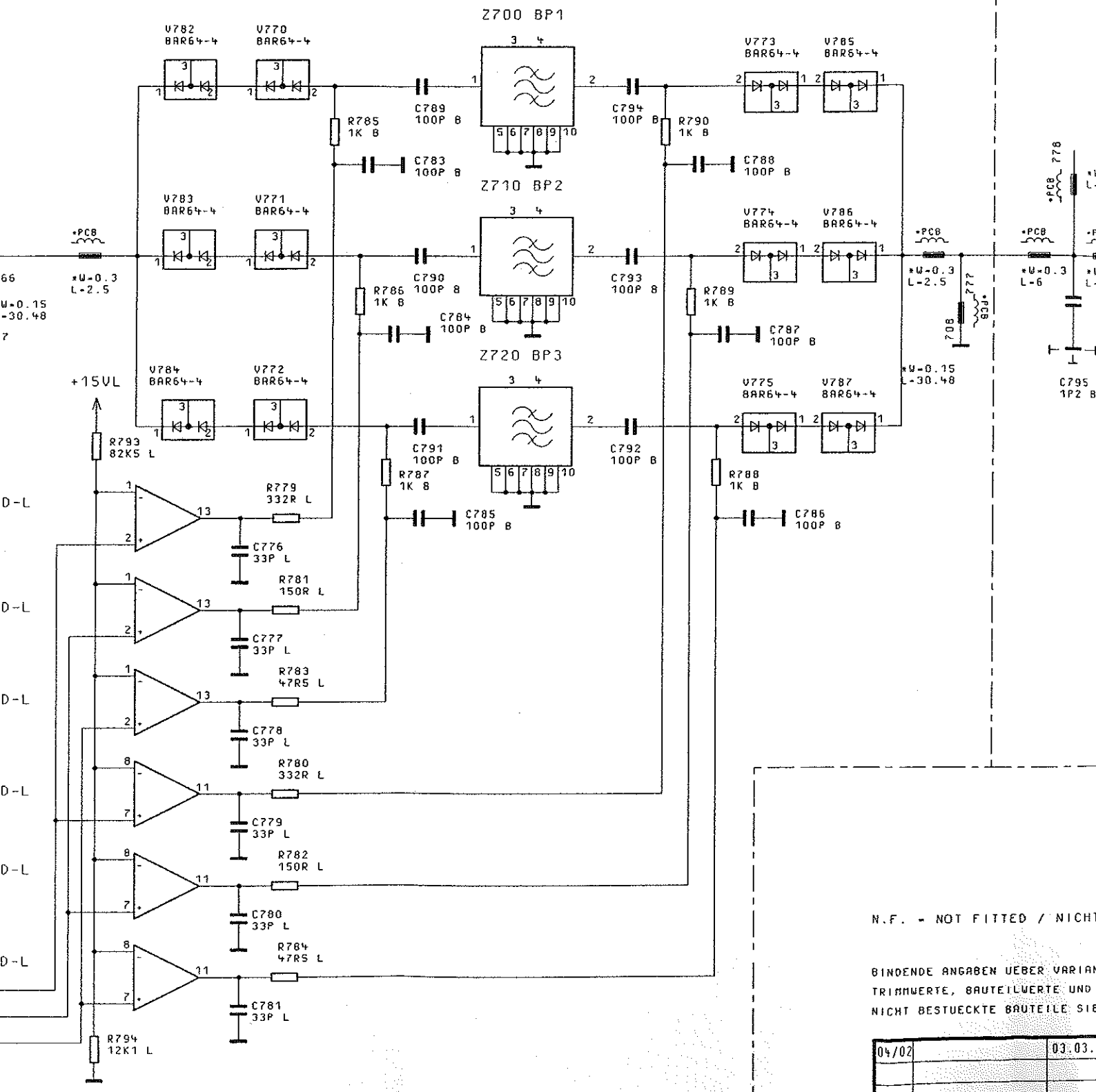

N.F. - NOT FITTED / NICHT

BINDENDE ANGABEN UEBER VARIAN
TRIMMWERTE, BAUTEILWERTE UND
NICHT BESTUECKTE BAUTEILE SIE

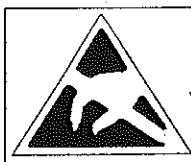

ACHTUNG: EGB!
ELEKTROSTATISCH GEFÄHRDETE
BAUELEMENTE ERFORDERN EINE
BESONDERE HANDHABUNG.
ATTENTION: ESD!
ELECTROSTATIC SENSITIVE DEVICES
REQUIRE A SPECIAL HANDLING

04/02	03.03.
04/01	16.12.
REND. IND.	ÄNDERUNGS- MITTEILUNG DATUM

AMPLIFIER 9

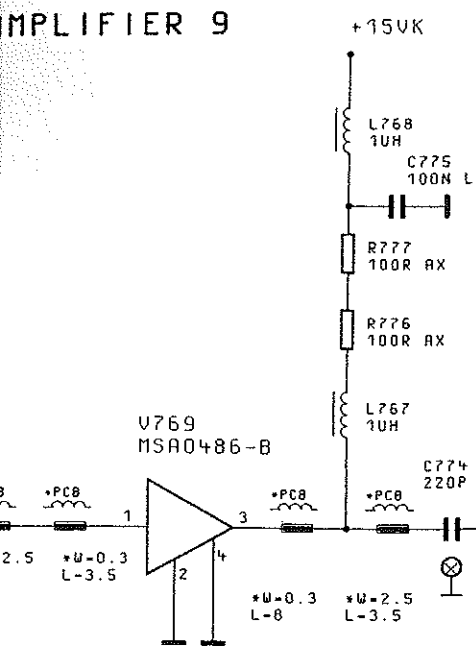

SWITCHED BANDPASS FILTERS

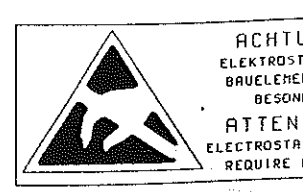
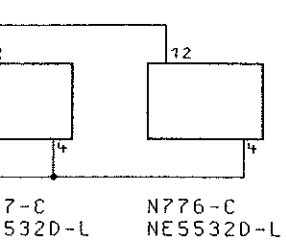
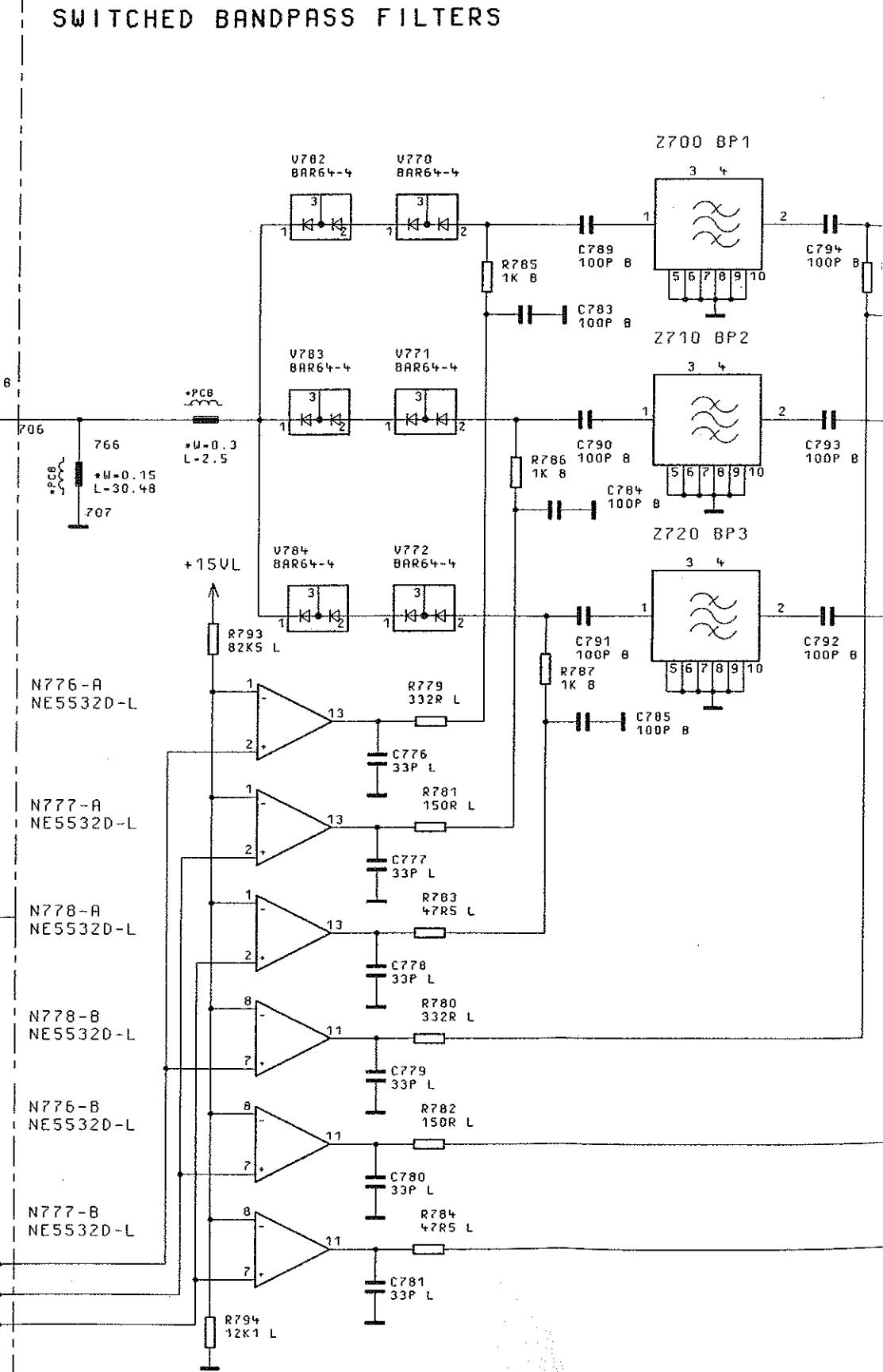

AMPLIFIER 9

SWITCHED BANDPASS FILTERS

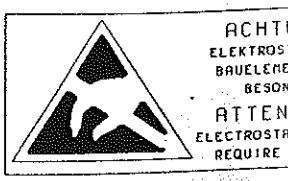
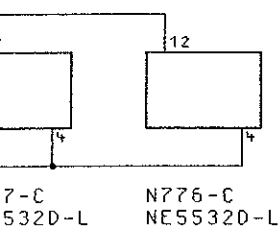
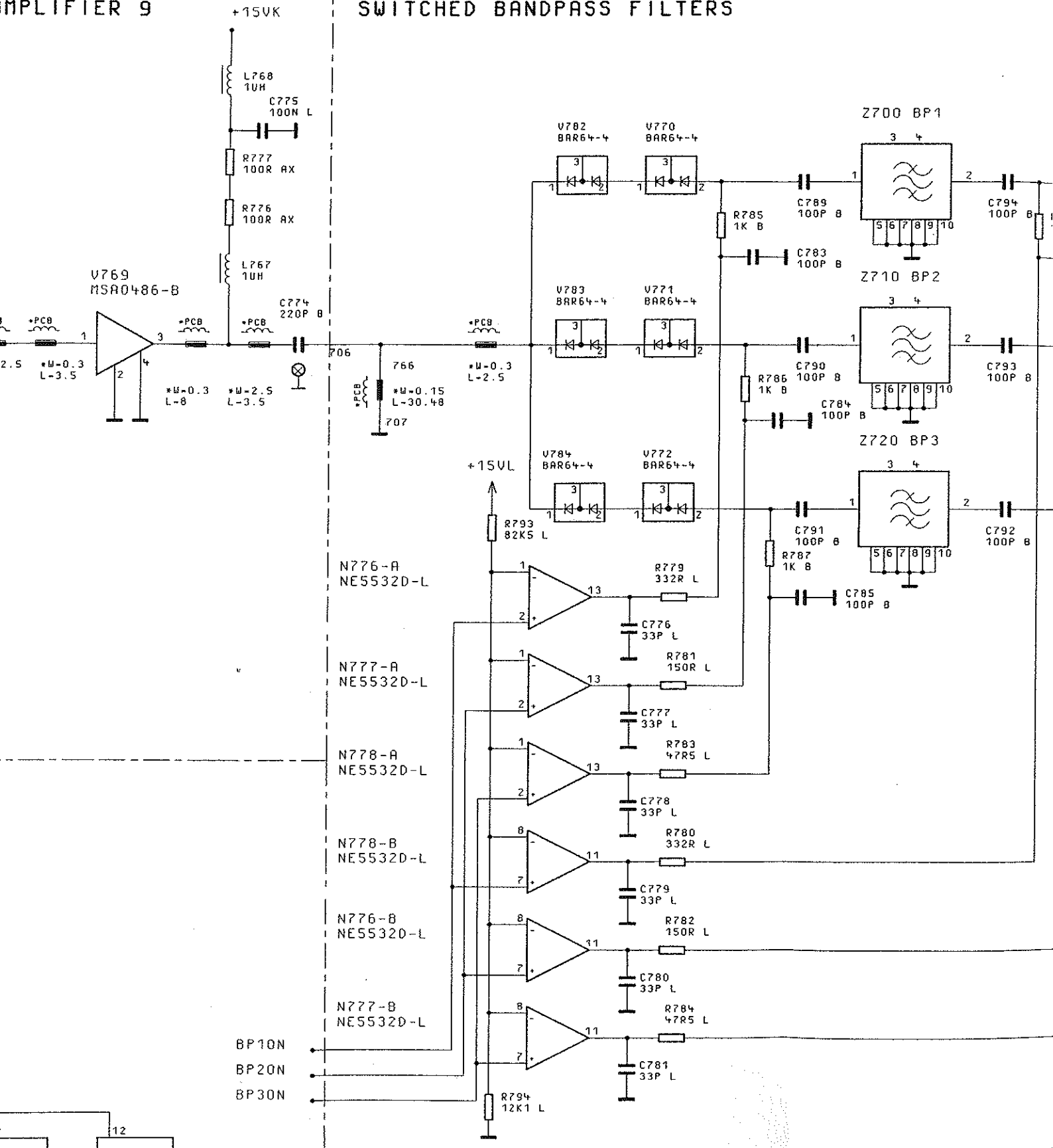

ACHTUNG
ELEKTROSTATISCHES
BAUELEMENT
BESONNEN
ATTENTION
ELECTROSTATIQUE
REQUIRE

RF AMPLIFIER 9

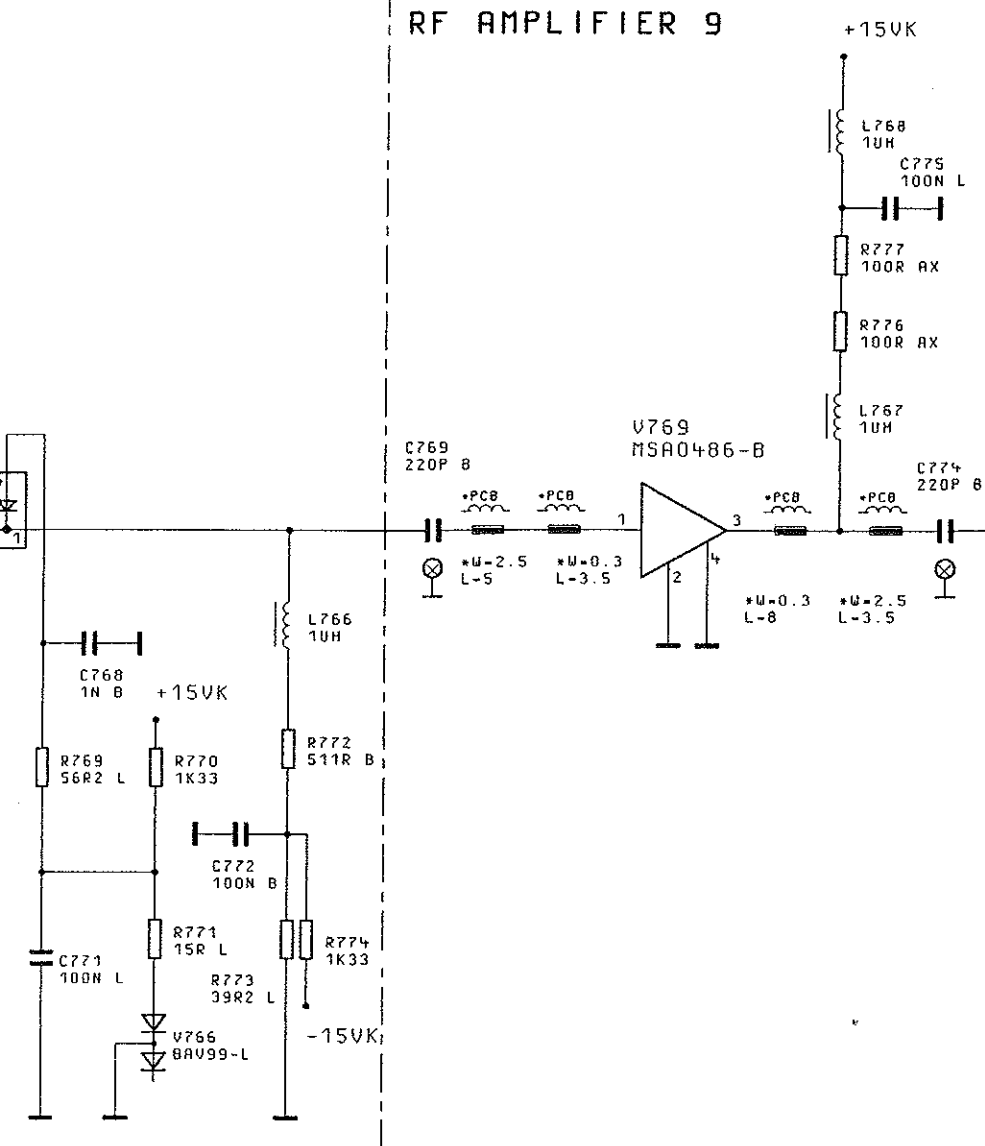

SWITCHED BANDPASS FILTERS

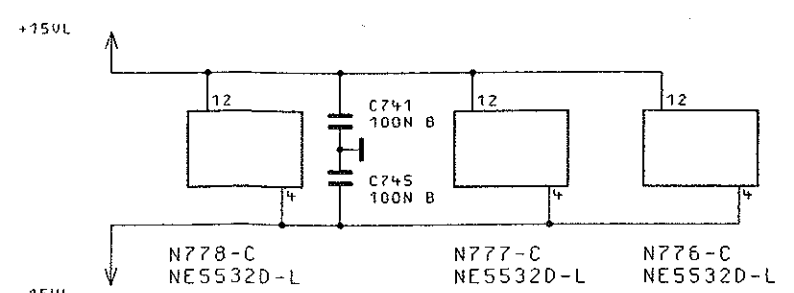
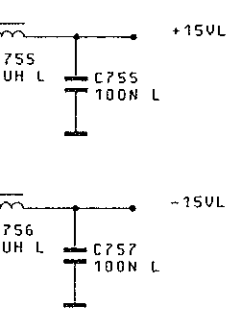
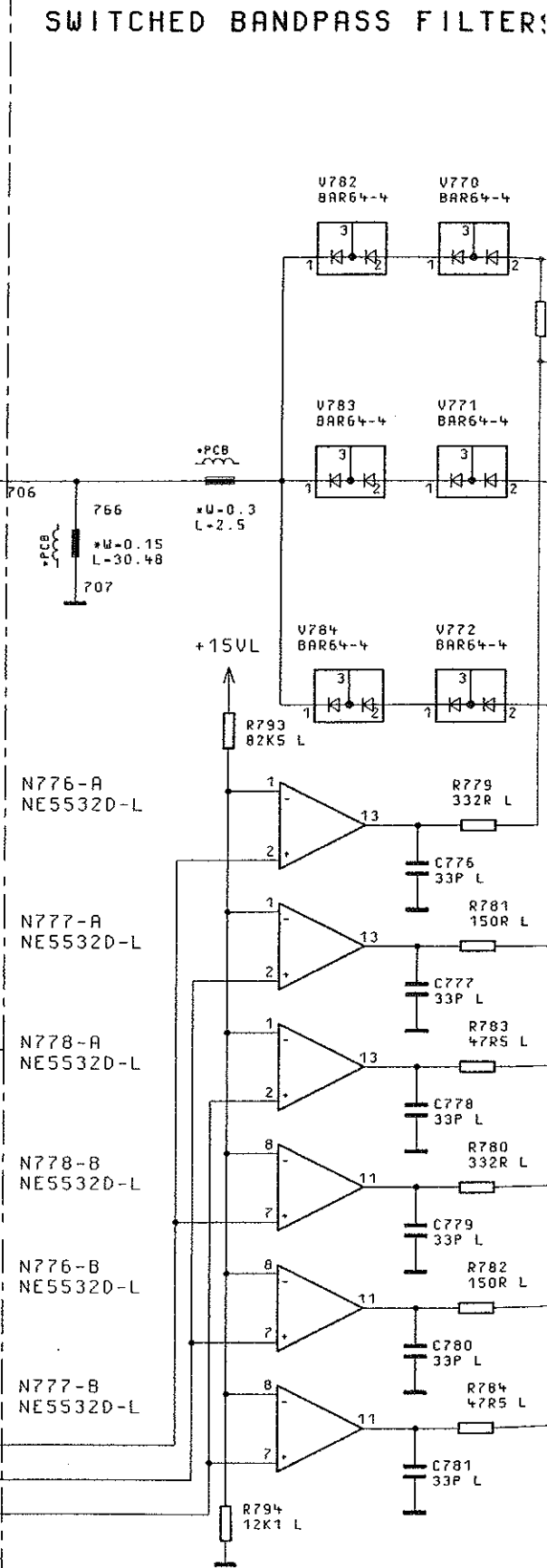

AM MODULATOR

RF AMPLIFIER 9

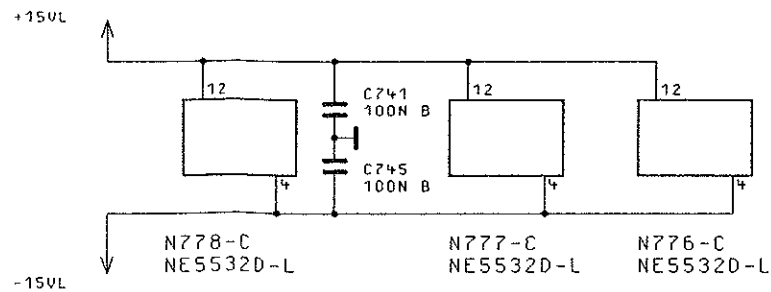
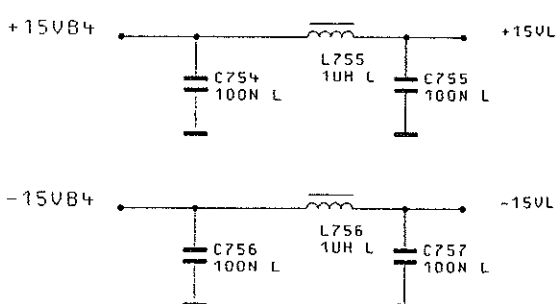
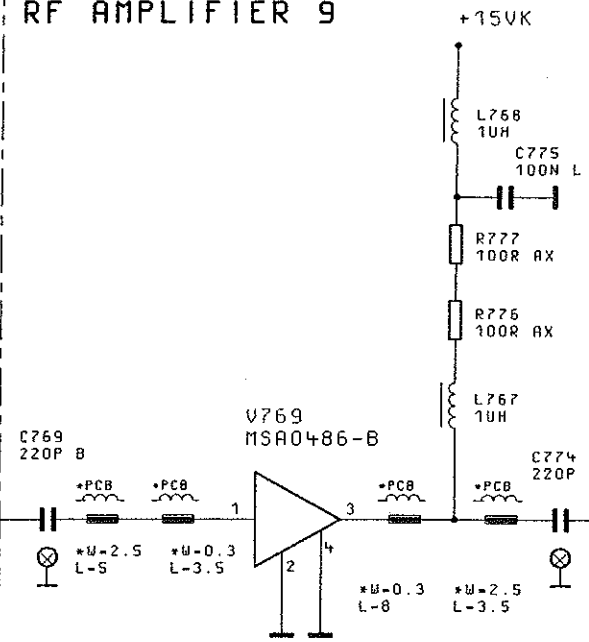
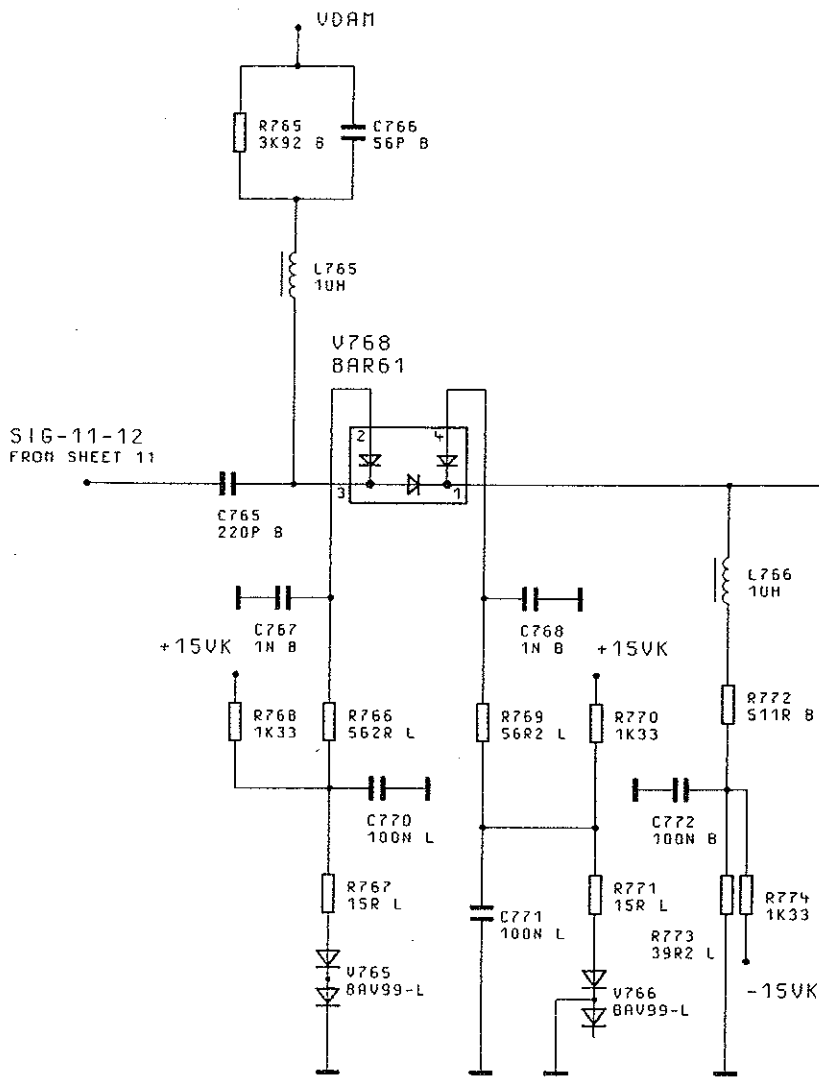

- BP10N
- BP20N
- BP30N

BEHALTEN DIR UNS ALLE RECHTE VOR
FUER DIESE UNTERLAGE

SIG-11-12
FROM SHEET 11

Signal-Name	Page-No.:	Zones			
+15VB1	02:	4F 5B 7C 03: 1B 4B 10D 06: 1A 10: 6A 10D			
+15VB2	05:	11C 11D 06: 2F 3A 9F			
+15VB3	02:	4F 04: 5D 6C 6D 7D 10E 11E 05: 3C 4C 6E			
+15VB4	02:	4E 07: 3F 08: 2E 09: 2B 11: 1B 12: 1B			
+15VE	07:	2F 3B 4F 5A 6A			
+15VF	07:	7F 9F			
+15VH	09:	3B			
+15VHI	07:	6F 08: 9E 09: 3B 4F 6A 7A 10C			
+15VK	11:	3B 3E 4E 7E 9C 10C 11C 12: 1D 3D 4F			
+15VL	10:	6A 10C 12: 2A 3B 5D 11F			
+24VH	02:	4E 09: 5F			
+5VB	02:	3C 4D 6A 8C 03: 1B 05: 8C 10: 1B 2F 3F 4F 5E 6F 7C 7F 8E 9E 9F 10F			
+9V-I	07:	1C 2C 4A			
-15VB1	02:	4E 5A 7A 03: 1A 4A 10: 6A 8B			
-15VB3	02:	4E 04: 4C 8C 05: 2C 4E			
-15VB4	02:	4E			
Druck 18.06.96	Abt. 1GPK	Name DR	Dat. 18.06.96	Ae.Mi.	Aei. 04
ROHDE & SCHWARZ	Benennung	AUSGANGSTEIL_2.08GHZ OUTPUT_UNIT_2.08GHZ		13+	
Typ. SMY	Reg in Verz.	1062.5502	V	Sachnummer	1062.7005 S

Signal-Name	Page-No.:	Zones			
-15VB4	07:	3F 08: 2D 09: 2A 11: 1A 12: 1B			
-15VE	07:	4F 6A 7A			
-15VHI	09:	3A 6A 8A			
-15VK	11:	3A 8B 8D 12B 12: 3C			
-15VL	08:	11C 10: 6A 12: 2A 3B			
-9V-I	07:	1B 3B 3D 4B			
ALCOFF	03:	1F 10: 7E			
AM	02:	4D 03: 1D			
AMINVERS	03:	1B 10: 3E			
AMSLOW	03:	1F 10: 7E			
BLANK	02:	4C 10: 1C			
BLANKENABLE	10:	3E			
BLANKINVERS	10:	3E			
BP10N	10:	7B 12: 4B			
BP20N	10:	7B 12: 4A			
BP30N	10:	7B 12: 4A			
CLK1	02:	4B 10: 1E			
DEFILT	02:	6D 08: 2E			
DETMIXON	03:	1E			
Druck 18.06.96	Abt.1GPK	Name DR	Dat.18.06.96	Ae.Mi.	Aei. 04
ROHDE & SCHWARZ	Benennung	AUSGANGSTEIL_2.08GHZ OUTPUT_UNIT_2.08GHZ		14+	
Typ. SMY	Reg in Verz.	1062.5502	V	Sachnummer	1062.7005 S

Signal-Name	Page-No. : Zones
DETMIXON	10: 7E
DETON	03: 1E 10: 7E
DIAG-0	02: 7E 10: 3E
DIAG-1	02: 7E 10: 3E
DIAG-2	02: 7E 10: 3E
DIAG-3	02: 7E 10: 3E
DIAGON	10: 3E
DOUBLEROUT	09: 2C 12: 12D
HF-INT-ENABLE	02: 11C 10: 3E
KLEMM-N	03: 1F 10: 8C
LPSELECT-0	05: 8D 10: 7C
LPSELECT-1	05: 8D 10: 7C
LPSELECT-2	05: 8D 10: 7B
LPSELECT-3	05: 8D 10: 7B
MODUFIX	03: 10C 10: 7E
RFBOUT	08: 12D 09: 1D
RFLEVENABLE	10: 7E
RFLOLEV	04: 12D 05: 1D
SACON	10: 7E
SACON-N	08: 9E
Druck 18.06.96	Abt.1GPK Name DR Dat.18.06.96 Ae.Mi. Aei. 04
ROHDE & SCHWARZ	Benennung AUSGANGSTEIL_2.08GHZ OUTPUT_UNIT_2.08GHZ 15+
Typ. SMY	Reg in Verz. 1062.5502 V Sachnummer 1062.7005 S

Signal-Name	Page-No.:	Zones			
SACON-N	09: 2F 10: 11B				
SACON-P	08: 9E 09: 2F 10: 11C				
SBDON	10: 5E				
SBDON-N	08: 2E 10: 11C				
SBDON-P	08: 2E 10: 11D				
SEROUT	02: 4C 10: 1E				
SIG-11-12	11: 12D 12: 1D				
SIG10	05: 7D 06: 1E				
SIG80-1	06: 11E 08: 1C				
SIG80-2	07: 1D 08: 5B				
SIG80-3	07: 12D 08: 11B				
TP1	05: 12E 06: 4F				
TP2	05: 12E 06: 6F				
TP3	05: 12D 06: 7F				
TP4	05: 12D 06: 2C				
TP5	05: 12D 06: 3C				
TP6	05: 12D 06: 5C				
TP7	05: 12C 06: 7C				
+-----+-----+-----+-----+-----+-----+					
Druck 18.06.96	Abt.1GPK	Name DR	Dat.18.06.96	Ae.Mi.	Aei. 04
+-----+-----+-----+-----+-----+-----+					
ROHDE & SCHWARZ	Benennung	AUSGANGSTEIL_2.08GHZ OUTPUT_UNIT_2.08GHZ		16+	
+-----+-----+-----+-----+-----+-----+					
Typ. SMY	Reg in Verz.	1062.5502	V	Sachnummer	1062.7005 S
+-----+-----+-----+-----+-----+-----+					

Signal-Name	Page-No. : Zones
TP8	05: 12C 06: 10C
U DOUBLER	02: 11E 11: 8E
ULPRE	02: 11E 03: 12E 05: 4E
UMODULATOR	02: 11E 03: 12C 04: 6E
UREF6	03: 9F 10: 11B
UREF6N	03: 4C 10: 11B
UREF9	09: 5C 6C 12B
UREF9N	09: 5A 6B 8B 12C
UREGELVERST	02: 6C 03: 11B
URF-SOLL	02: 11E 03: 7C
VDAM	03: 11B 11: 10E 12: 2F
VDET	02: 11E 03: 1E 09: 8B
VDETMIX	02: 11E 03: 1F 07: 5F
VDETMIXE	07: 4C 5F
VDEXT	02: 4F 03: 1E
VDEXTON	03: 1E 10: 7E
WR1	02: 4B 10: 1E

Druck 18.06.96	Abt.1GPK	Name DR	Dat.18.06.96	Ae.Mi.	Aei. 04
ROHDE & SCHWARZ	Benennung	AUSGANGSTEIL_2.08GHZ OUTPUT_UNIT_2.08GHZ		17-	
Typ. SMY	Reg in Verz.	1062.5502	V	Sachnummer	1062.7005 S

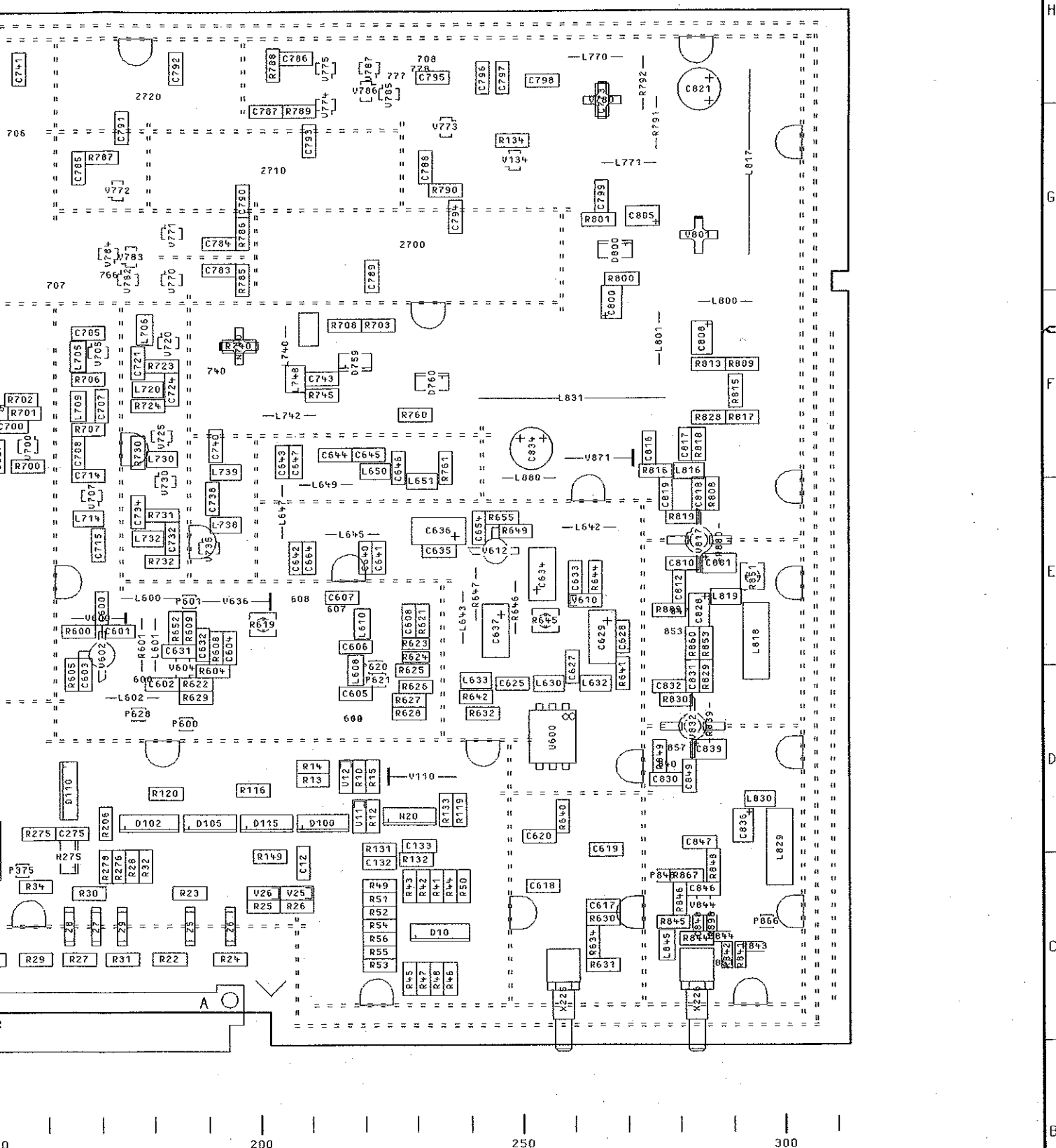

03/	17.06.96	DR	16PK	TAG	NARE	BENENNUNG
			BEAPP.		DR	AUSGANGSTEIL 2.08GHZ
			GEPP.			OUTPUT UNIT 2.08GHZ
			NOPI			
			PLOTT	17.06.96		
REND	RENDPUNGS-	DATUM	NARE	ZEICHN.-NR.		
IND.	MITTEILUNG			ROHDE&SCHWARZ	1062.7005.01	EE
			ZU GEHÖRT SMY	VERF. U. V.	1062.5502	EPSTE 2. 1062.5502

H
G
F
E
D
C
B
A

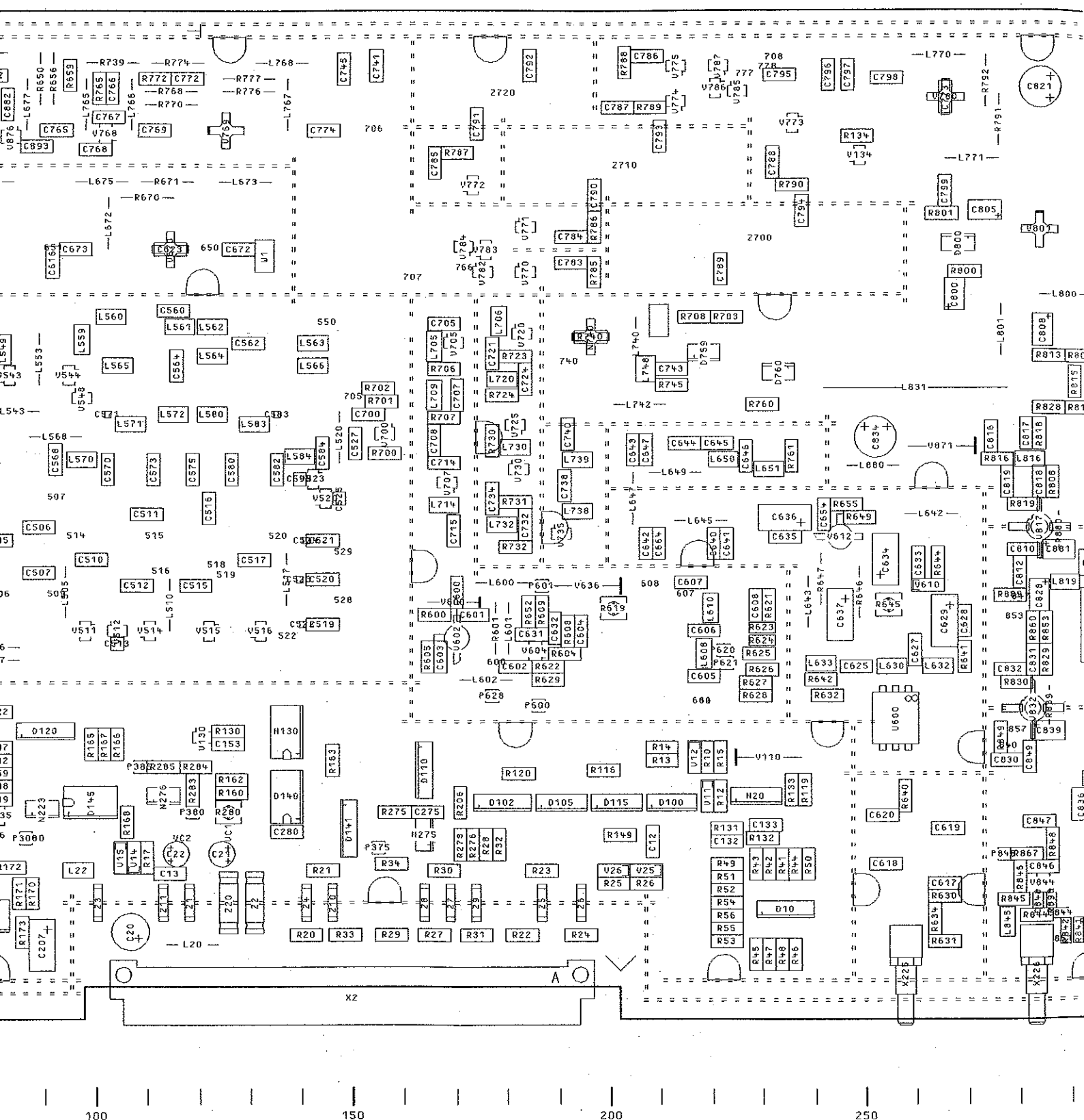

PARTEILISTEN, UND
SIEHE SA.
ON MODELS.
VALUES AND
PARTS LIST.

83/		17.06.96	DR	16PK	TAG	NARE	BE
				BEPP.		DR	
				NOPR			
				PE011	17.06.96		
REND	RENDEPONES- RITTEILUNG	DATUM	NARE	ROHDE & SCHWARZ			
				28 GERRET	SMY		

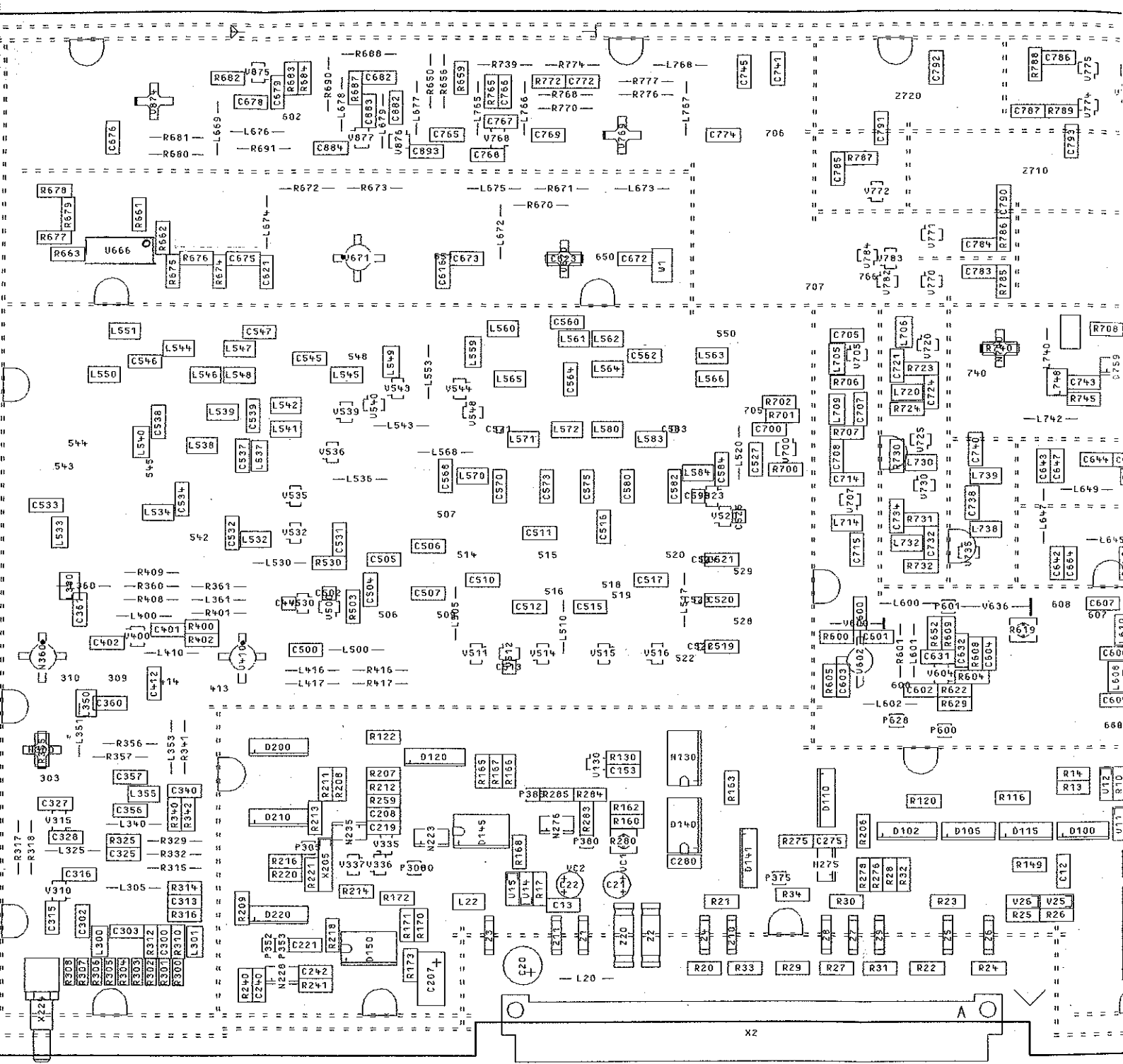

50 100 150 200

ACHTUNG: ESD!
 ELEKTROSTATISCH GEFÄHRDETE
 BAUELEMENTE ERFORDERN EINE
 BESONDERE HANDHABUNG.
ATTENTION ESD!
 ELECTROSTATIC SENSITIVE DEVICES
 REQUIRE A SPECIAL HANDLING

BINDENDE ANGABEN UEBER VARIANTEN,
 TRAHWERTE, BAUTEILWERTE UND
 NICHT BESTUECKTE BAUTEILE SIEME SR.
 FOR BINDING INFORMATION ON MODELS,
 TRAHING AND COMPONENTS VALUES AND
 NONFITTED COMPONENTS SEE PARTS LIST.

200
150
100
50
0

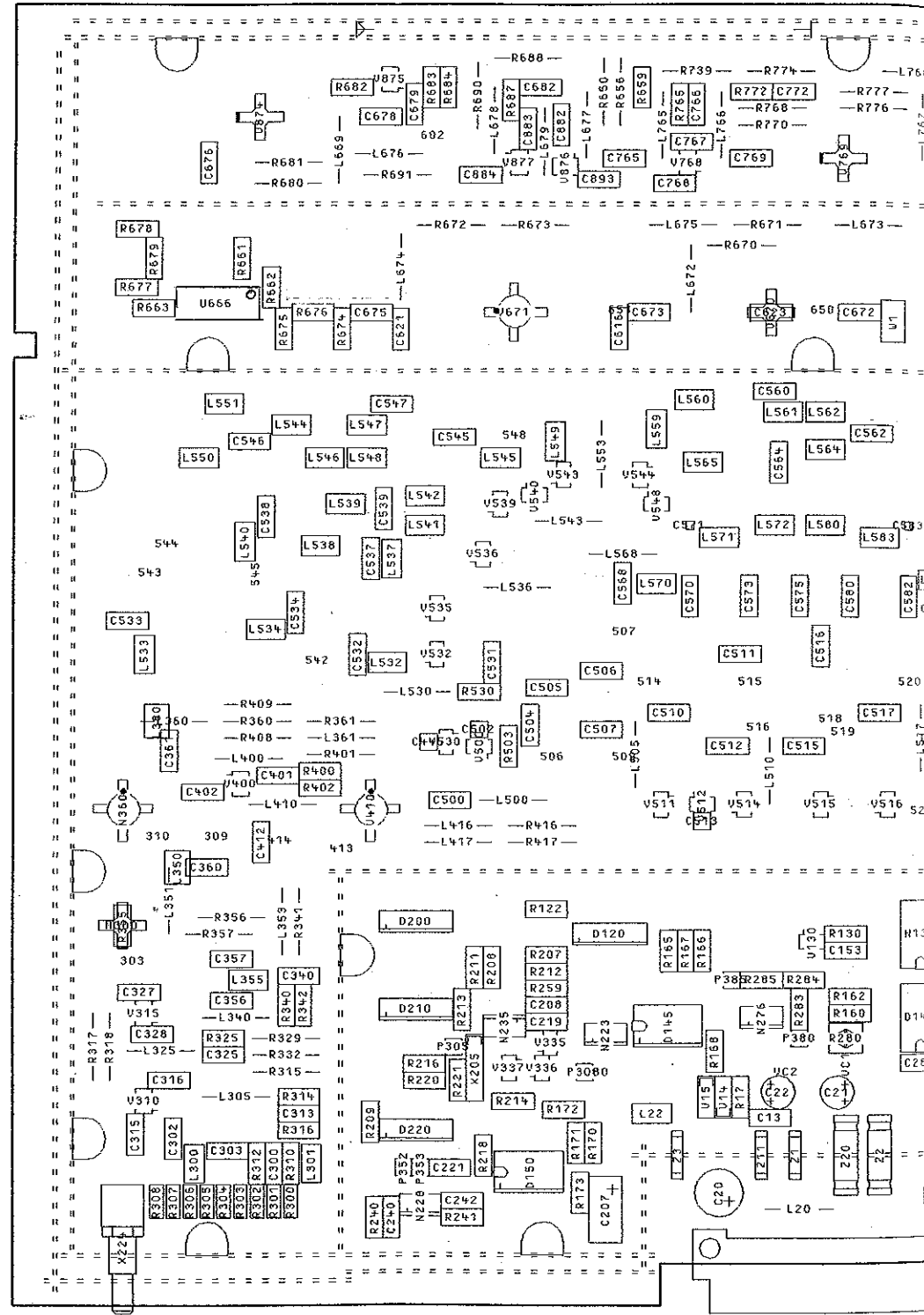

FÜR DIESE ZEICHNUNG BEHALTEN SICH ALLE RECHTE VOR.
DIESE ZEICHNUNG IST EIN RECHNERGEGENSTÄNDLICHES, RECHNERGEGENSTÄNDLICHES DURCH DEN DATENSATZ ERZIELT.

DARSTELLUNG SEITE B
VIEW ON SIDE B



ACHTUNG: ESD!
ELEKTROSTATISCH GEFÄHRDETE
BAUELEMENTE ERFORDERN EINE
BESONDERE HANDHABUNG.
ATTENTION ESD!
ELECTROSTATIC SENSITIVE DEVICES
REQUIRE A SPECIAL HANDLING

BINDENDE ANGABEN ÜBER VARIANTEN,
TRIMWERTE, BAUTEILWERTE UND
NICHT BESTÜCKTE BAUTEILE SIEHE SA.

FOR BINDING INFORMATION ON MODELS,
TRIMMING AND COMPONENTS VALUES AND
NONFITTED COMPONENTS SEE PARTS LIST.

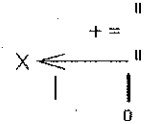
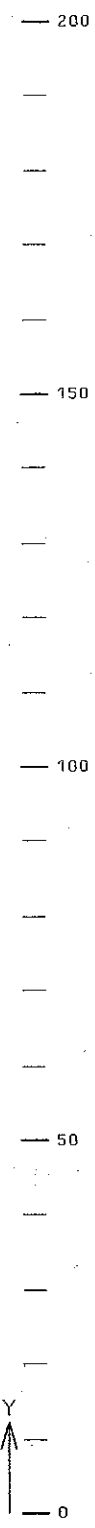
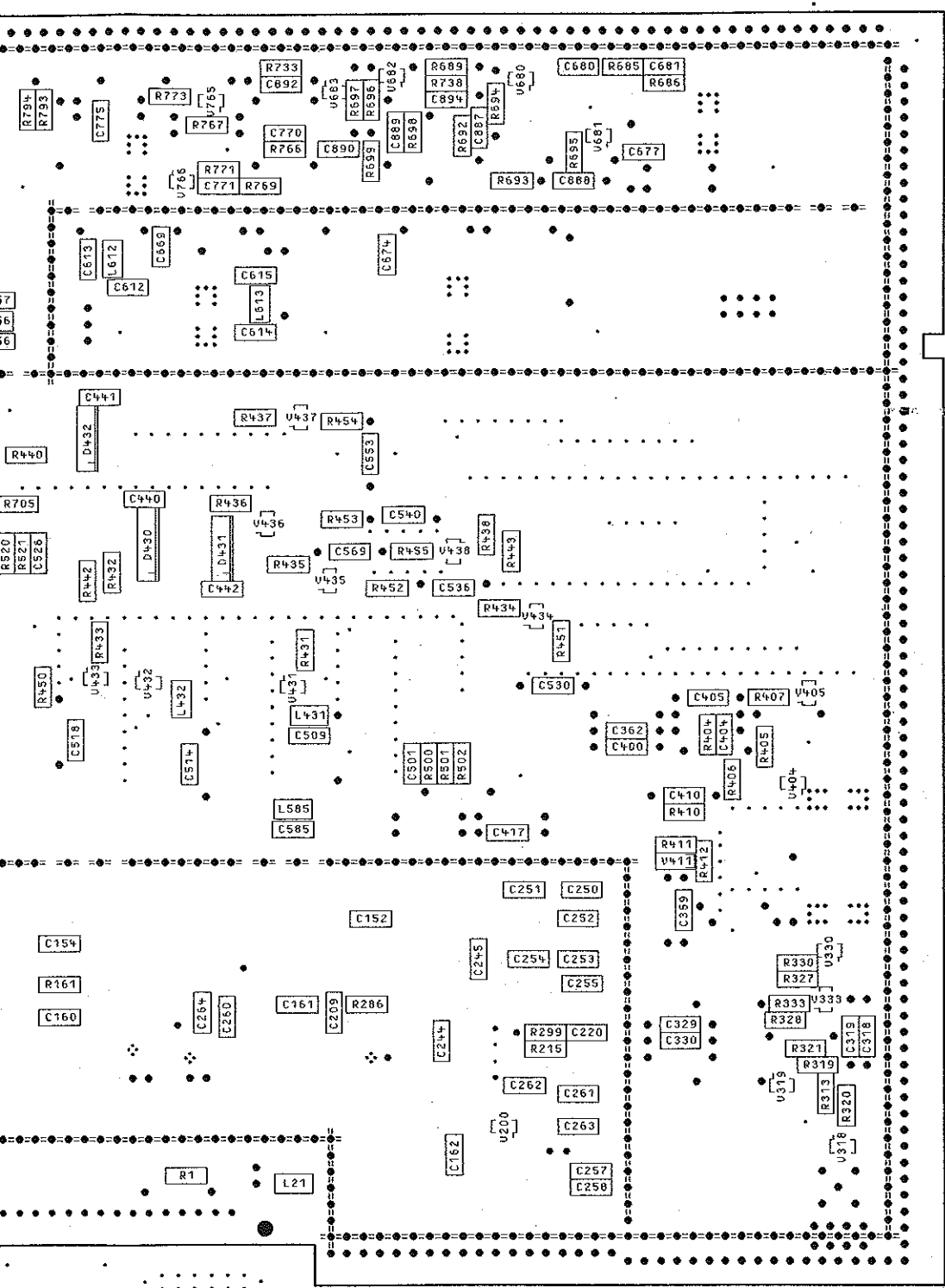

03/		17.06.96	DR	1GPK	TRG	NAME	BENENNUNG	
				BEARB.		DR	AUSGANGSTEIL 2.086GHZ	Z
				GEPR.			OUTPUT UNIT 2.086GHZ	
				NDPR				
				PLOTT	17.06.96			
						ZEICHN.-NR.		BLATT-NR.
						1062.7005.01	EE	24
HERD.	HERDENUNGS-	DATUM	NAMEN	ZU GEHÖRT	SHY	PEC. I. U.	1062.5502	ERSTE Z.
IND.	MITTEILUNG						1062.5502	3 BL.

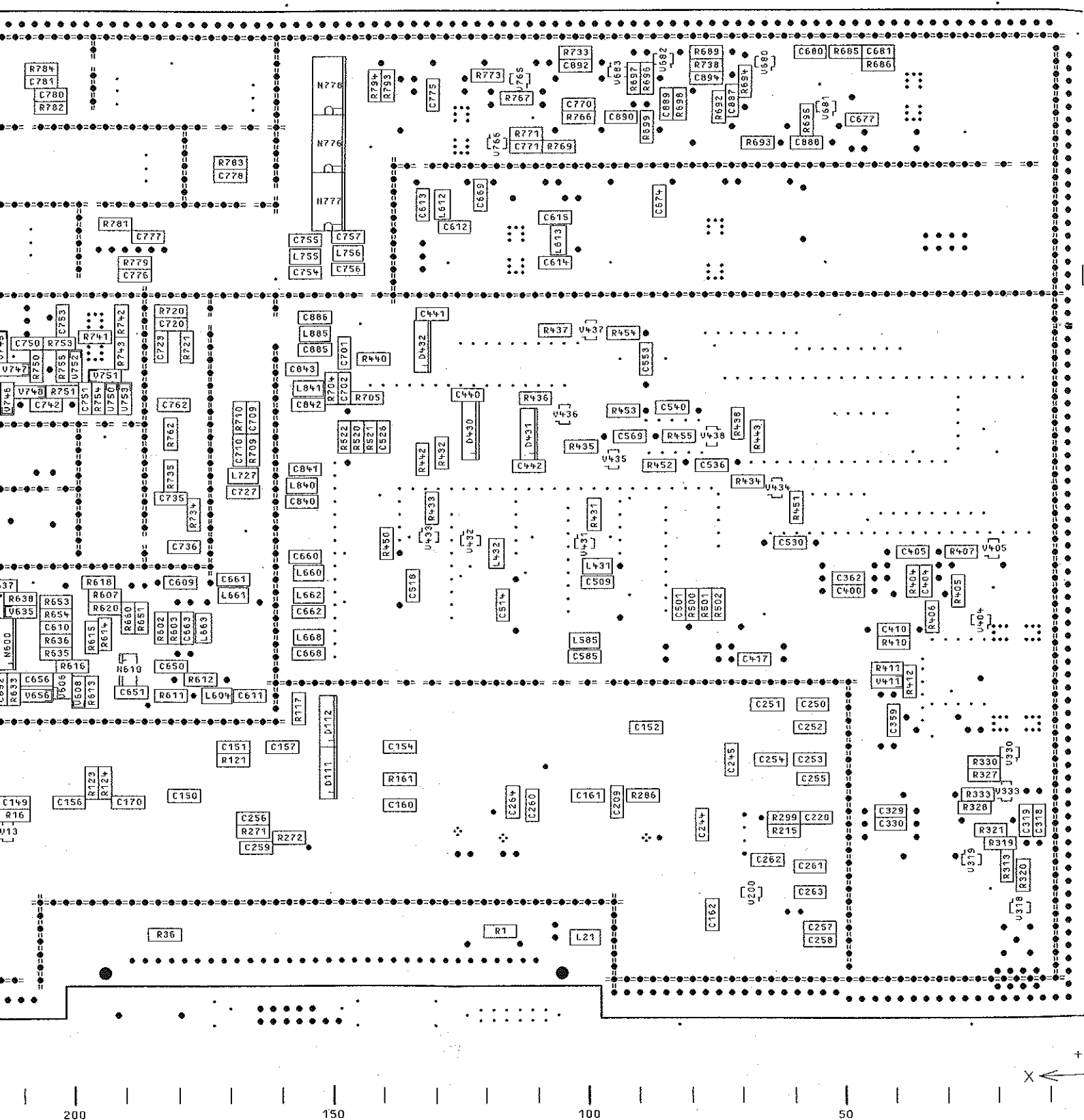

RIANTEN,
 BND
 E SIEME SA.
 ON MODELS,
 VALUES AND
 PARTS LIST.

03/		17.06.96	DR	1GPK	1AG	KARE	BEARH
				GEPR.		DR	
				HOPI			
				PLQTT	17.06.96		ZETCH
REND. TRD.	RENDERINGS- FITTE LUNG	DATUM	NAM	ROHDE & SCHWARZ			
				ZU GEHRET SMY			REG. 1 V

5 6 7 8 9 10

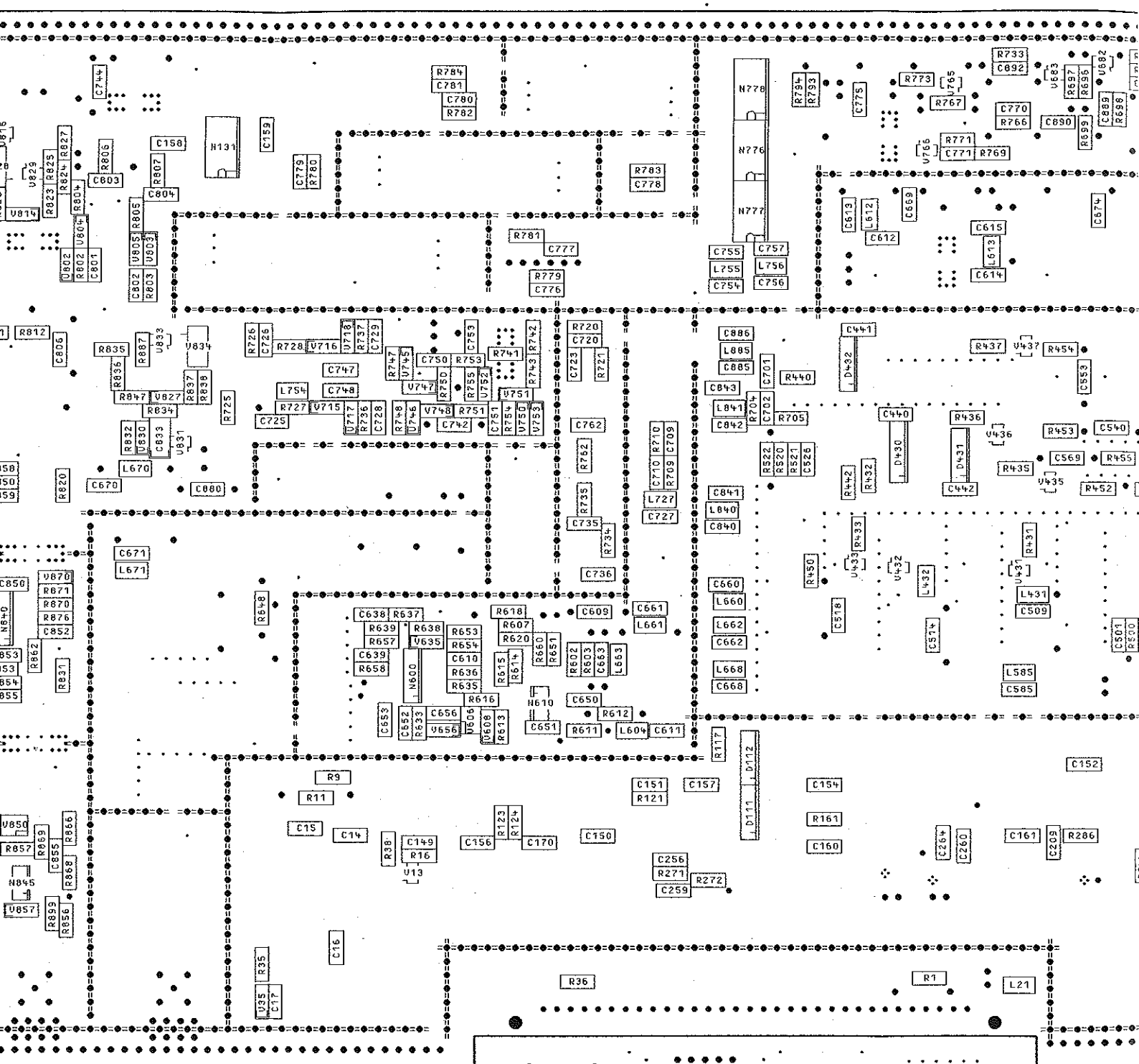

250 200 150 100

ACHTUNG: EGB!
ELEKTROSTATISCH GEFÄHRDETE
BAUELEMENTE ERFORDERN EINE
BESONDERE HANDLUNG.

ATTENTION ESD!
ELECTROSTATIC SENSITIVE DEVICES
REQUIRE A SPECIAL HANDLING

BINDENDE ANGABEN UEBER VARIANTEN,
TRIMMWERTE, BAUTEILWERTE UND
NICHT BESTUECKTE BAUTEILE SIEHE SR.

FOR BINDING INFORMATION ON MODELS,
TRIMMING AND COMPONENTS VALUES AND
NONFITTED COMPONENTS SEE PARTS LIST.

H

G

U

F

E

D

C

B

A

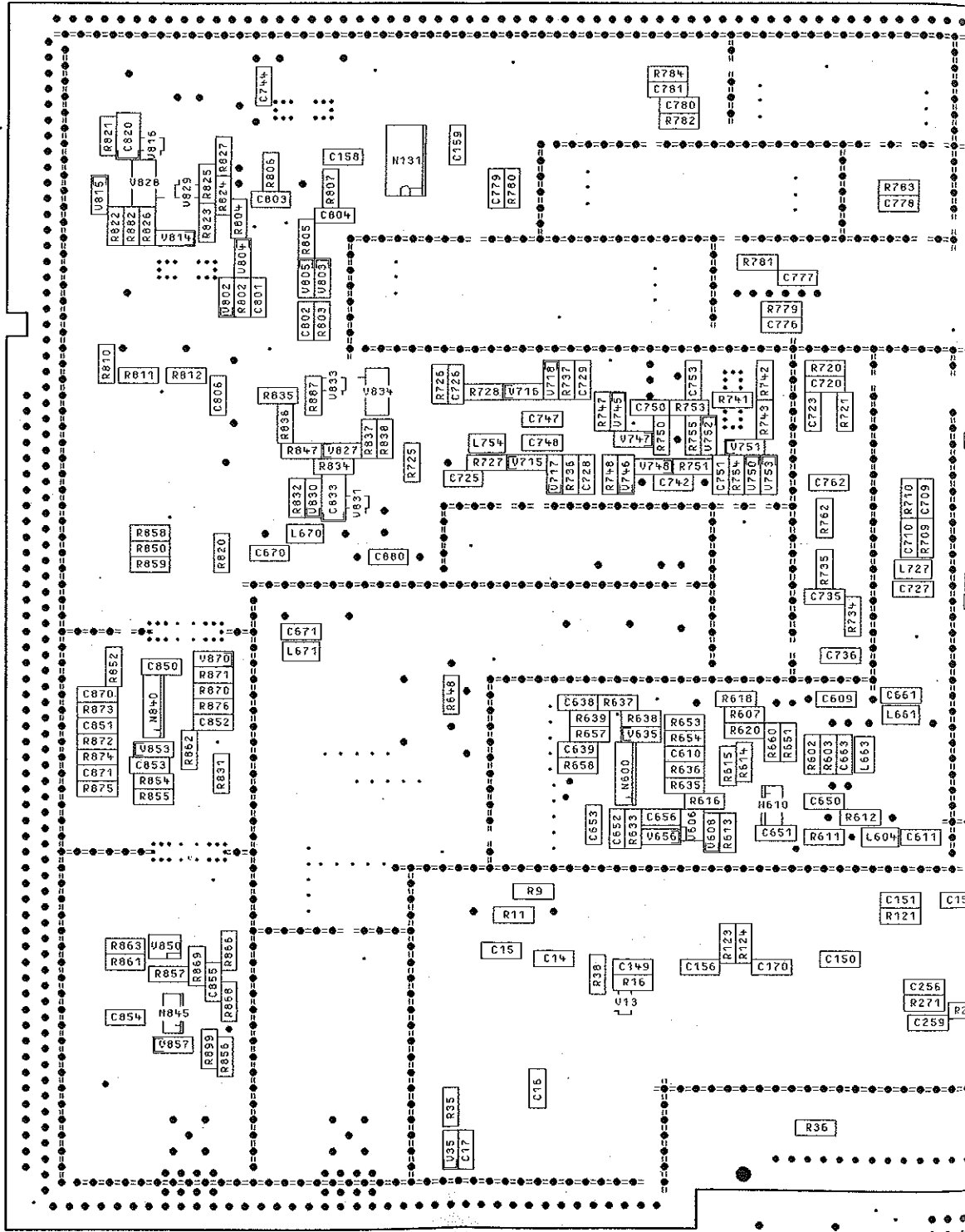

FUER DIESE ZEICHNUNG BEHALTEN SICH ALLE RECHTE VOR.
DIESE ZEICHNUNG IST EIN RECHNERDRUCK. ANFORDERUNGEN KÖNNEN NUR DURCH SENDERN DES DATENSATZES ERFOLGEN

DARSTELLUNG SEITE A
VIEW ON SIDE A



ACHTUNG: ESD!
ELEKTROSTATISCH GEFÄHRDETE BAUELEMENTE ERFORDERN EINE BESONDERE HANDLUNG.
ATTENTION: ESD!
ELECTROSTATIC SENSITIVE DEVICES REQUIRE A SPECIAL HANDLING.

BINDENDE ANGABEN UEBER VARIANTEN,
TRIMMWERTE, BAUTEILWERTE UND
NICHT-BESTUECKTE BAUTEILE SIEHE 'SA'.
FOR BINDING INFORMATION ON MODELS,
TRIMMING AND COMPONENTS VALUES AND
NONFITTED COMPONENTS SEE PARTS LIST.



ROHDE & SCHWARZ

SERVICEUNTERLAGEN

Eichleitung 1 GHz

0826.5065.01

Inhaltsverzeichnis

7 Prüfen und Instandsetzen der Baugruppe.....	5
7.1 Funktionsbeschreibung.....	5
7.1.1 Eichleitung mit integriertem Überspannungsschutz.....	5
7.1.2 Ansteuerung der Eichleitung.....	5
7.2 Meßgeräte und Hilfsmittel.....	6
7.3 Fehlersuche.....	6
7.3.1 Ansteuercode.....	6
7.3.2 Ansteuerpuls der Dämpfungsglieder.....	6
7.4 Prüfen und Abgleich.....	7
7.4.1 Prüfen der Dämpfungsglieder und der Ansteuerdruckschaltung.....	7
7.4.2 Prüfen des Überspannungsschutzes.....	7
7.4.2.1 Statische Prüfung.....	7
7.4.2.2 Prüfung und Abgleich bei Gleichspannung (nur VAR04).....	8
7.4.2.3 Prüfung bei Wechselspannung (nur VAR04).....	8
7.4.2.4 Prüfung und Abgleich bei Wechselspannung (nur VAR02).....	8
7.4.2.5 Prüfung bei Gleichspannung (nur VAR02).....	8
7.4.3 Schnittstellen.....	9

Schaltteilliste
Koordinatenliste
Stromlauf
Bestückungsplan

ACHTUNG!!!

Die Baugruppe darf nicht geöffnet werden, da sonst der Garantieanspruch erlischt und ein Neuabgleich durchgeführt werden muß.

Für SMY ohne Option SMY-B40 ist für diese Baugruppe die Variante 02 erforderlich.

Für SMY mit Option SMY-B40 ist für diese Baugruppe die Variante 04 erforderlich.

7.1 Funktionsbeschreibung

(Siehe hierzu Stromlauf und Blockschaltbild 0826.5065.01S)

7.1.1 Eichleitung mit integriertem Überspannungsschutz

Die Eichleitung ist zwischen das Ausgangsteil (bzw. der Baugruppe Powermodul bei Geräten mit Option SMY-B40) und den Geräteausgang geschaltet. Mit ihr kann das Signal um 130dB in 10dB-Stufen abgesenkt werden. Kleinere Pegelsprünge werden mit Hilfe der elektronischen Pegelregelung eingestellt. Die Eichleitung des SMY01 enthält fünf Dämpfungsglieder mit den Werten 10, 2*20 und 2*40dB, ein Überspannungsschutzsubstrat und ein 50 Ohm Abschlußwiderstand. Die Dämpfungsglieder können durch jeweils eine Kontaktgruppe, die aus drei Einzelkontakten besteht, eingeschaltet oder überbrückt werden. Jede dieser Kontaktgruppen wird von einer Wippe betätigt, die von einer Magnetspule angetrieben und durch einen Permanentmagneten in der Endlage gehalten wird.

Hinter den Dämpfungsgliedern sitzt auf der Eichleitungsgrundplatte in Richtung Geräteausgang das Überspannungsschutzsubstrat und anschließend der RF-OFF-Schalter. Das Überspannungsschutzsubstrat erkennt hohe DC-Spannungen und HF-Pegel, welche an die Ausgangsbuchse X1 angelegt werden und betätigt den RF-OFF-Schalter. Der RF-OFF-Schalter kann aber auch vom Rechner über die Software bedient werden.

7.1.2 Ansteuerung der Eichleitung

Die Dämpfungseinstellung erfolgt durch serielle Datenübertragung (siehe 7.3.1). Die Ansteuerbits werden über die Datenleitungen (X77.B1 SERDAT) mit dem Clock (X77.B2 SERCLK) in das Schieberegister (D5) auf der Eichleitungsansteuerdruckschaltung geschoben. Mit dem Strobe (X77.B3 ELSTB) werden die Ausgänge des Schieberegisters gesetzt und die gewünschte Dämpfung eingestellt. Die Ansteuerung der Magnetspulen der Kontaktgruppen erfolgt über die Leistungsgatter D1 bis D4.

Beim SMY01 wird eine zu hohe HF-Spannung an der Ausgangsbuchse durch eine Spitzenwertgleichrichtdiode erkannt. Eine zu hohe DC-Spannung wird durch einen Widerstand detektiert. Im Überspannungsfall sprechen die Komperatoren N10 a,b an und setzen das Flip-Flop D6, welches über eine Verstärkerstufe V30 und das Gatter D4 direkt den RF-Schalter betätigt.

Dem Rechner wird der Überlastfall über die Interruptleitung (X77.B4) mitgeteilt. Dieser Interrupt wird dann rückgesetzt, wenn der RF-OFF-Schalter zusätzlich vom Rechner über Software betätigt wird. Der RF-OFF-Schalter kann von Hand über die Tastenfolge 'LEVEL ON' wieder geschlossen werden.

7.2 Meßgeräte und Hilfsmittel

1. Ohmmeter (Meßbereich bis 2M Ω)
2. Leistungsmeßsender (z.B. SMGL)
3. Gleichspannungsnetzgerät für $\pm 15V$
4. Speicheroszilloskop

7.3 Fehlersuche

7.3.1 Ansteuercode

Läßt sich am Gerät ein gewünschter Ausgangspegel nicht einstellen, so muß am Schieberegisterausgang D5 der ordnungsgemäße Ansteuercode der einzelnen Dämpfungsglieder überprüft werden (siehe Tabelle 7.3.1).

Tabelle 7.3.1 für ATT01 im SMY01 (CW-Betrieb):

Ansteuercode am Schieberegister D5 (74HC 4094)

Pegeleinstellung		Pin5	6	4	7	14	11,9
mit	ohne	Q2	Q3	Q1	Q4	Q5	Q8, Q9
Option SMY-B40		40dB	20dB	10dB	20dB	40dB	RF-OFF
19 dBm	13 dBm	1	1	1	1	1	0
6 dBm	0 dBm	1	1	0	1	1	0
-4 dBm	-10 dBm	1	1	1	0	1	0
-24 dBm	-30 dBm	1	1	1	1	0	0
-64 dBm	-70 dBm	0	1	1	1	1	0
-84 dBm	-90 dBm	0	1	1	0	0	0
-104 dBm	-110 dBm	0	0	1	0	0	0
-114 dBm	-120 dBm	0	0	0	0	0	0

'1' = 5V, '0' = 0V

7.3.2 Ansteuerpuls der Dämpfungsglieder

Entspricht der Puls an den Magnetspulen D1 bis D4 nicht der in Bild 7.3.2 gezeichneten Form, so liegt ein auftretender Dämpfungsfehler an der Ansteuerdruckschaltung und nicht an den Dämpfungsgliedern mit den zugehörigen Kontaktgruppen vor.



Bild 7.3.2

7.4 Prüfen und Abgleich

7.4.1 Prüfen der Dämpfungsglieder und der Ansteuerdruckschaltung

Hierzu ist zu verfahren wie in Kapitel 5.2.6 der Wartungsunterlage im Betriebshandbuch beschrieben ist.

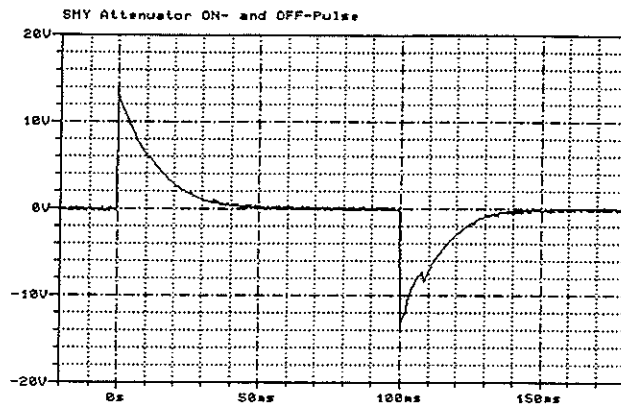
7.4.2 Prüfen des Überspannungsschutzes

7.4.2.1 Statische Prüfung

- Stecker X41 von der Eichleitungsansteuerdruckschaltung abziehen.
- Einen Ausgangspegel von -117dBm einstellen.

Mit einem Ohmmeter kann nun die Diode des Überspannungsschutzes in Sperr- und Durchlaßrichtung gemessen werden.

- Die Messung erfolgt zwischen Masse und dem Durchführungsfilter Z11.

Mit einem Ohmmeter kann auch der DC-Spannungsmeßwiderstand gemessen werden.

- Die Messung erfolgt zwischen dem RF-Ausgang und dem Durchführungsfilter Z12. Der Sollwert beträgt $6 \pm 1\text{k}\Omega$.

7.4.2.2 Prüfung und Abgleich bei Gleichspannung (nur VAR04)

- Mit Pot R14 die Spannung an N10/2 auf $1.4 \text{ V} \pm 10 \text{ mV}$ einstellen.
 - An die RF-Ausgangsbuchse X1 des Geräts eine DC-Spannung aus einer Gleichspannungsquelle anlegen.
- _ Der RF-OFF-Schalter muß bei Spannungen an der RF-Buchse von $\pm(7.5 \text{ V} \dots 8.5 \text{ V})$ ansprechen.

Ein Rücksetzen des RF-OFF-Schalters erfolgt mit der Tastenkombination 'LEVEL ON'.

7.4.2.3 Prüfung bei Wechselspannung (nur VAR04)

- Einen Ausgangspegel von -117 dBm einstellen.
 - Einen Leistungsmeßsender mit dem RF-Ausgang des SMY verbinden und eine RF von 100 MHz einstellen.
- _ Der RF-OFF-Schalter muß bei $30 \dots 33 \text{ dBm}$ ansprechen.

Ein Rücksetzen des RF-OFF-Schalters erfolgt mit der Tastenkombination 'LEVEL ON'.

7.4.2.4 Prüfung und Abgleich bei Wechselspannung (nur VAR02)

- Einen Ausgangspegel von -117 dBm einstellen.
 - Einen Leistungsmeßsender mit dem RF-Ausgang des SMY verbinden und eine RF von 1000 MHz einstellen.
- _ Der RF-OFF-Schalter muß bei $0.3 \dots 0.7 \text{ W}$ ansprechen, ein Abgleich kann mit dem Potentiometer R14 erfolgen.

Ein Rücksetzen des RF-OFF-Schalters erfolgt mit der Tastenkombination 'LEVEL ON'.

7.4.2.5 Prüfung bei Gleichspannung (nur VAR02)

- An die RF-Ausgangsbuchse X1 des Geräts eine DC-Spannung aus einer Gleichspannungsquelle anlegen.
- _ Der RF-OFF-Schalter muß bei Spannungen $\pm(5 \dots 7 \text{ V})$ ansprechen.

Ein Rücksetzen des RF-OFF-Schalters erfolgt mit der Tastenkombination 'LEVEL ON'.

7.4.3 Schnittstellen

Pin	Name	Ein/Ausgang	Herkunft/Ziel	Wertebereich	Signalbeschreibung
X77.A1	GND				
X77.B1	SERDAT	Eingang	Rechner X3.4	TTL-HCT	Serielle Daten
X77.A2	GND				
X77.B2	SERCLK	Eingang	Rechner X3.2	TTL-HCT	Clocksignal
X77.A3	GND				
X77.B3	ELSTB	Eingang	Rechner X3.19	TTL-HCT	Strobesignal
X77.A4	GND				
X77.B4	HFOVERLOAD	Ausgang	Rechner X3.22	TTL-HCT	Overload Interrupt
X77.A5	GND				
X77.B5	frei				
X77.A6	VA5-P	Eingang	Netzteil X21.5	+4.5 .. +5.3V 42 ±8mA	Versorgung +5.1V
X77.B6	"	"	"	"	"
X77.A7	VA15-P	"	" X21.13	+14.9 .. +15.6V 20 ±4mA	Versorgung +15V
X77.B7	"	"	"	"	"
X77.A8	VA15-N	"	" X21.19	-15.5 .. -14.4V 3 ±.5V	Versorgung -15V
X77.B8	"	"	"	"	"
X1		Eingang	Ausgangsteil		
X2		Ausgang	RF-Buchse		



ROHDE & SCHWARZ

SERVICE INSTRUCTIONS

Attenuator 1GHz

0826.5065.01

Contents

7 Testing and Repair of the Module	5
7.1 Function Description	5
7.1.1 Attenuator with Overvoltage Protection.....	5
7.1.2 Control of the Attenuator.....	5
7.2 Test Instruments and Utilities	6
7.3 Troubleshooting	6
7.3.1 Control Code.....	6
7.3.2 Control Pulse of the Attenuator Pads.....	7
7.4 Testing and Adjustment	7
7.4.1 Testing the Attenuator Pads and the Control P.C.B....	7
7.4.2 Testing the Overvoltage Protection.....	7
7.4.2.1 Static Test.....	7
7.4.2.2 Testing with DC Power Supply (VAR04 only)	8
7.4.2.3 Testing with AC Supply (VAR04 only)	8
7.4.2.4 Testing and Adjustment with AC (VAR02 only) ..	8
7.4.2.5 Testing with DC Voltage Supply (VAR02 only) ..	8
7.4.3 Interfaces.....	9

Parts list
List of coordinates
Circuit diagram
Components layout diagram

CAUTION!!!

Do not open the module, since otherwise the warranty expires and re-adjustment is required.

For instruments without option SMY-B40, this module with VAR02 is necessary.

For instruments with option SMY-B40, this module with VAR04 is necessary.

7.1 Function Description

(Cf. circuit diagram and block diagram 0826.5065.01S)

7.1.1 Attenuator with Overvoltage Protection

The attenuator is connected between the output module (the power module for instruments with option SMY-B40, respectively) and the instrument output. It is used to attenuate the signal by 130 dB in steps of 10 dB. Smaller level jumps are set via the electronic level control. The attenuator of the SMY01 consists of five attenuator pads of 10, 2*20 and 2*40 dB, an overvoltage-protection substrate and a 50-Ohm terminator. The attenuator pads can be switched on or bypassed by means of one contact group each, which consists of three individual contacts. Each of these contact groups is actuated by a rocker, which is driven by a magnetic coil and kept in end position by a permanent magnet.

The overvoltage-protection substrate and the RF-OFF switch are accommodated on the attenuator motherboard subsequent to the attenuator pads. The overvoltage-protection substrate detects high dc voltages and RF levels which are applied to the output socket X1 and actuates the RF-OFF switch. The RF-OFF switch may also be software-controlled via the controller.

7.1.2 Control of the Attenuator

The attenuation is set via serial data transmission (cf. 7.3.1). The control bits are clocked into the shift register (D5) on the attenuator control p.c.b. via the data lines (X77.B1 SERDAT) using the clock X77.B2 SERCLK. The strobe (X77.B3 ELSTB) sets the outputs of the shift registers and the desired attenuation. The magnetic coils of the contact groups are controlled via the power gates D1 to D4.

A peak-responding rectifier diode fitted to the SMY01 detects an unpermissibly high RF voltage at the output socket. An unpermissibly high dc voltage is detected by a resistor.

In case of overvoltage, the comparators N10 a,b respond and set the flip-flop D6, which directly actuates the RF switch via an amplifier stage V30 and the gate D4.

The information on overload is passed to the controller via the interrupt line (X77.B4). This interrupt is reset if the RF-OFF switch is additionally software-controlled. The RF-OFF switch can be reset manually via the key sequence 'LEVEL ON'.

7.2 Test Instruments and Utilities

1. Ohmmeter (Measuring range up to 2 MOhms)
2. Power generator (e.g., SMGL)
3. DC power supply for $\pm 15V$
4. Storage oscilloscope

7.3 Troubleshooting

7.3.1 Control Code

If a desired output level can not be set on the instrument, check at the shift register D5 whether the control code of the individual attenuator pads is correct (see table 7.3.1).

Table 7.3.1 for ATT01 in SMY01 (CW mode):

Control code at shift register D5 (74HC 4094)

Level setting		Pin5	6	4	7	14	11,9
with	without	Q2	Q3	Q1	Q4	Q5	Q8,Q9
option SMY-B40		40 dB	20 dB	10 dB	20 dB	40 dB	RF-OFF
19 dBm	13 dBm	1	1	1	1	1	0
6 dBm	0 dBm	1	1	0	1	1	0
-4 dBm	-10 dBm	1	1	1	0	1	0
-24 dBm	-30 dBm	1	1	1	1	0	0
-64 dBm	-70 dBm	0	1	1	1	1	0
-84 dBm	-90 dBm	0	1	1	0	0	0
-104 dBm	-110 dBm	0	0	1	0	0	0
-114 dBm	-120 dBm	0	0	0	0	0	0

'1' = 5V, '0' = 0V

7.3.2 Control Pulse of the Attenuator Pads

If the pulse at the magnetic coils D1 to D4 does not correspond to the form illustrated in fig. 7.3.2, an error occurred on the control p.c.b., the attenuator pads with the associate contact groups are, however, o.k.

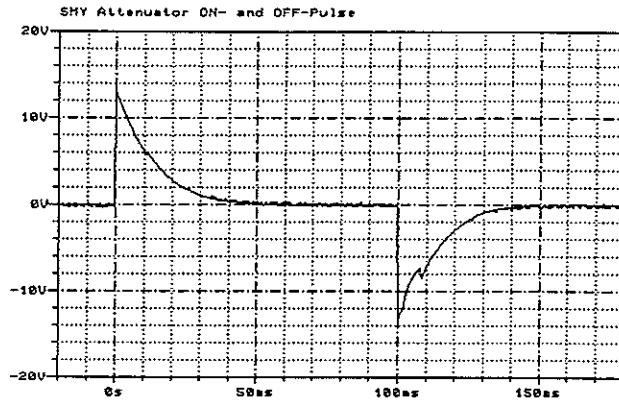

Fig. 7.3.2

7.4 Testing and Adjustment

7.4.1 Testing the Attenuator Pads and the Control P.C.B.

Proceed as described in Section 5.2.6 of the maintenance instructions given in the operating manual.

7.4.2 Testing the Overvoltage Protection

7.4.2.1 Static Test

- Withdraw connector X41 from the attenuator p.c.b.
- Set output level to -117dBm.

The overvoltage-protection diode can be measured in forward and reverse direction using an ohmmeter.

- The measurement can be performed between ground and the lead-through filter Z11.

The shunt of the dc voltage can also be measured using an ohmmeter.

- The measurement is performed between the RF output and the lead-through filter Z12. The rated value is $6 \pm 1\text{k}\Omega$.

7.4.2.2 Testing with DC Power Supply (VAR04 only)

- Use pot R14 to set the voltage at N10/2 to $1.4 \text{ V} \pm 10 \text{ mV}$.
- Apply a dc voltage from a dc power supply to the RF output socket X1 of the instrument.

— The RF-OFF switch must respond for voltages between $\pm (7.5 \text{ V to } 8.5 \text{ V})$ at the RF-socket.

The RF-OFF switch is reset using the key combination 'LEVEL ON'.

7.4.2.3 Testing with AC Supply (VAR04 only)

- Set output level to -117 dBm .
- Connect a signal generator to the RF output of the SMY and set an RF of 100 MHz .

— The RF-OFF switch must respond for $30 \dots 33 \text{ dBm}$.

The RF-OFF switch is reset using the key combination 'LEVEL ON'.

7.4.2.4 Testing and Adjustment with AC (VAR02 only)

- Set output level to -117 dBm .
- Connect a signal generator to the RF output of the SMY and set an RF of 1000 MHz .
- Supplying with $0.3 \dots 0.7 \text{ W}$, the RF-OFF switch must respond. It can be adjusted using the potentiometer R14.

— The RF-OFF switch is reset using the key combination 'LEVEL ON'.

7.4.2.5 Testing with DC Voltage Supply (VAR02 only)

- Apply a dc voltage from a dc power supply to the RF output socket X1 of the instrument.

— The RF-OFF switch must respond with voltages $\pm(5 \dots 7 \text{ V})$.

The RF-OFF switch is reset using the key combination 'LEVEL ON'.

7.4.3 Interfaces

Pin	Name	Input/Output	Origin/Dest.	Specified range	Signal description
X77.A1	GND				
X77.B1	SERDAT	Input	Controller X3.4	TTL-HCT	Serial data
X77.A2	GND				
X77.B2	SERCLK	Input	Controller X3.2	TTL-HCT	Clock signal
X77.A3	GND				
X77.B3	ELSTB	Input	Controller X3.19	TTL-HCT	Strobe signal
X77.A4	GND				
X77.B4	HFOVERLOAD	Output	Controller X3.22	TTL-HCT	Overload interrupt
X77.A5	GND				
X77.B5	not used				
X77.A6	VA5-P	Input	P. supply X21.5	+4.5 to +5.3V 42 ±8mA	+5.1V supply
X77.B6	"	"	"	"	"
X77.A7	VA15-P	"	" X21.13	+14.9 to +15.6V 20 ±4mA	+15V supply
X77.B7	"	"	"	"	"
X77.A8	VA15-N	"	" X21.19	-15.5 to -14.4V 3 ±.5V	-15V supply
X77.B8	"	"	"	"	"
X1		Input	Output module		
X2		Output	RF socket		

Schalteillisten
Stromläufe
Bestückungspläne
Part lists
Circuit diagrams
Components plans
Listes des pièces détachées
Schémas de Circuit
Plans des composants

Für diese Unterlage behalten wir uns alle Rechte vor.

Kennz. Comp. No.	Benennung Designation	Sachnummer Stock No.	Hersteller Manufacturer	Bezeichnung Designation	enthalten in contained in
.	XX VARIANTENERKLAERUNG IDENTIFICATION OF MODELS VAR 02 = GRUNDAUSFUEHRUNG MOD 02 = BASIC MODEL ERSETZT/REPLACE VAR 00/MOD 00 VAR 04 = SMY11/41+B40 MOD 04 = SMY11/41+B40				
A71	ED ANSTEUERUNG.EICHLTG. ATTENAUATOR CONTROL NUR VAR/ONLY MOD: 02 ZUEGH.STROML./CIRC.DIAGR. 826.5065S	0826.5071.02			
A71	ED ANSTEUERUNG EICHLTG. NUR VAR/ONLY MOD: 04 ZUEGH.STROML./CIRC.IAGR. 826.5065S	0826.5071.04			
C3	CE 220UF+-20%35V RM5	CE 0008.7904.00	PANASONIC	ECA-1VFG221BQ	0826.5071.01
..7	ELECTROLYTIC CAPACITOR				
C8	CE 100UF+-20%35V RM5	0008.7510.00	PHILIPS_CO	2222 116 90042	0826.5071.01
	ELECTROLYTIC CAPACITOR				
C10	CK 100NF+-5%63VRD2,5H7MKT CAPACITOR	CK 0099.2930.00	ROEDERSTEI	MKT 1826-410-06-4W	0826.5071.01
C11	CK 100NF+-5%63VRD2,5H7MKT CAPACITOR	CK 0099.2930.00	ROEDERSTEI	MKT 1826-410-06-4W	0826.5071.01
C13	CE 1,5UF+-20%25V 5X 4X 7 ELECTROLYTIC CAPACITOR	CE 0087.9334.00	KEMET	T340 A155M025 AS	0826.5071.01
C14	CC 10NF-20+50%7X8R4000 CAPACITOR	CC 0087.7525.00	VALVO	2222 640 51103	0826.5071.01
C16	CC 10NF-20+50%7X8R4000 CAPACITOR	CC 0087.7525.00	VALVO	2222 640 51103	0826.5071.01
C18	CC 10NF-20+50%7X8R4000 CAPACITOR	CC 0087.7525.00	VALVO	2222 640 51103	0826.5071.01
C30	CE 47UF+-20%63V RM5	0008.7440.00	PHILIPS_CO	2222 116 90112	0826.5071.01
	ELECTROLYTIC CAPACITOR				
C31	CE 47UF+-20%63V RM5	0008.7440.00	PHILIPS_CO	2222 116 90112	0826.5071.01
	ELECTROLYTIC CAPACITOR				
C32	CE 47UF+-20%63V RM5	0008.7440.00	PHILIPS_CO	2222 116 90112	0826.5071.01
	ELECTROLYTIC CAPACITOR				
C100	CC 150NF+-10% 50V8K1200LR CAPACITOR	0092.0919.00	KEMET	C 062 T 154 K5X5CR	
D2	BJ SN75361AP 2XTTL/MOS-LC LEVEL CONVERTER	BJ 0294.8490.00	NSC	DS75361N	0826.5071.01
D3	BJ SN75361AP 2XTTL/MOS-LC LEVEL CONVERTER	BJ 0294.8490.00	NSC	DS75361N	0826.5071.01
D4	BJ SN75361AP 2XTTL/MOS-LC LEVEL CONVERTER	BJ 0294.8490.00	NSC	DS75361N	0826.5071.01
D5	BL PC74HC4094P 8ST.SH.REG 8ST.SHIFT A.STORE REGIST.	0099.9711.00	PHILIPS_SE	(PC)74HC4094N(P)	0826.5071.01
D6	BL CD4013BE 2XD- FLIPFL FLIPFLOP	0086.7021.00	RCA	CD4013BE	0826.5071.01
K1	LD ELEKTROMAGNET (EICHL.) ELECTROMAGNET	0294.8425.00			0294.8877.00
..6					
N10	BO LF412CN 2XFET OPAMP OPERATIONAL AMPLIFIER	0356.0521.00	NSC	LF412CN	0826.5071.01
R6	RL 0,60W 4,75KOHM+-1%TK50 RESISTOR	RL 0083.1097.00	RESISTA	MK2	0826.5071.01
R7	RL 0,60W 121KOHM+-1%TK50 RESISTOR	RL 0083.2070.00	RESISTA	MK2	0826.5071.01
R8	RL 0,60W 1KOHM+-1%TK50 RESISTOR	RL 0082.2160.00	RESISTA	MK2	0826.5071.01
R9	RL 0,60W 1KOHM+-1%TK50 RESISTOR	RL 0082.2160.00	RESISTA	MK2	0826.5071.01
R10	RL 0,60W 1KOHM+-1%TK50 RESISTOR	RL 0082.2160.00	RESISTA	MK2	0826.5071.01
R12	RL 0,60W 8,25KOHM+-1%TK50 RESISTOR	RL 0083.1239.00	RESISTA	MK2	0826.5071.01
R14	RS 0,5W1KOHM+-10%10X10X5 CERMET POTENTIOMETER T	RS 0087.7560.00	BOURNS	3386F-1-102	0826.5071.01
R18	RL 0,60W 10,0KOHM+-1%TK50 RESISTOR	RL 0083.1297.00	RESISTA	MK2	0826.5071.01

095.0028-0893



ROHDE & SCHWARZ

21

16.09.97

ZE EICHLITUNG (SMX)

0826.5065.01 SA

1+

Für diese Unterragge benötigen wir uns alle Rechte vor.

Kennz. Comp. No.	Benennung Designation	Sachnummer Stock No.	Hersteller Manufacturer	Bezeichnung Designation	enthaltene in contained in	
R21	RL 0,60W 10,0KOHM+-1%TK50 RESISTOR	RL 0083.1297.00	RESISTA	MK2	0826.5071.01	
R22	RL 0,60W 4,75KOHM+-1%TK50 RESISTOR	RL 0083.1097.00	RESISTA	MK2	0826.5071.01	
R30	RL 0,60W 12,1KOHM+-1%TK50 RESISTOR	RL 0083.1351.00	RESISTA	MK2	0826.5071.01	
R31	RL 0,60W 4,75KOHM+-1%TK50 RESISTOR	RL 0083.1097.00	RESISTA	MK2	0826.5071.01	
V1	AE BZX55/B10 0,5W ZDI ZENER DIODE	AE 0289.4302.00	VALVO	BZX79B10	0826.5071.01	
V2	AE BZX55/B10 0,5W ZDI ZENER DIODE	AE 0289.4302.00	VALVO	BZX79B10	0826.5071.01	
V3	AE BZX79/B5V6 0,5W ZDI ZENER DIODE	AE 0012.5254.00	VALVO	BZX79B5V6	0826.5071.01	
V3	NUR VAR/ONLY MOD: 02 AE BZX79/B6V8 0,5W ZDI ZENER DIODE	AE 0586.9906.00	PHILIPS	BZX79B6V8	0826.5071.01	
V4	NUR VAR/ONLY MOD: 04 AD 1N4448 75V UDI DIODE	AD 0012.0700.00	PHILIPS_SE	1N4448 "	0826.5071.01	
V5	AE BZX79/B5V6 0,5W ZDI ZENER DIODE	AE 0012.5254.00	VALVO	BZX79B5V6	0826.5071.01	
V5	NUR VAR/ONLY MOD: 02 AE BZX79/B6V8 0,5W ZDI ZENER DIODE	AE 0586.9906.00	PHILIPS	BZX79B6V8	0826.5071.01	
V6	NUR VAR/ONLY MOD: 04 AD 1N4448 75V UDI DIODE	AD 0012.0700.00	PHILIPS_SE	1N4448 "	0826.5071.01	
V8	AD 1N4448 75V UDI DIODE	AD 0012.0700.00	PHILIPS_SE	1N4448 "	0826.5071.01	
V9	AK BCY79IX P 45V 200MA TRANSISTOR	AK 0010.3777.00	VALVO	BCY79IX	0826.5071.01	
V20	AD 1N4448 75V UDI DIODE	AD 0012.0700.00	PHILIPS_SE	1N4448 "	0826.5071.01	
V21	AD 1N4448 75V UDI DIODE	AD 0012.0700.00	PHILIPS_SE	1N4448 "	0826.5071.01	
V30	AK BCY59IX N 45V 200MA TRANSISTOR	AK 0010.5163.00	VALVO	BCY59IX	0826.5071.01	
W41	DX KABEL W41 CABLE W41	0826.8370.00				
X1	FJ EINBAUBUCHSE SYST.SMA SOCKET	FJ 0294.8154.00	SUHNER	22SMA-50-0-26/111NH	0294.8983.00	
X2	FJ EINBAUBUCHSE SYST.SMA SOCKET	FJ 0294.8154.00	SUHNER	22SMA-50-0-26/111NH	0294.8983.00	
X41	FP STIFTL.WIN 36P.R2,54 ANGLE PIN CONNECTOR	FP 0087.9105.00	BINDER	742-5-11-0191-00-36	0826.5071.01	
X100	3-POLIG/3 PINS FP BUCHSE VERTIKAL P.V. 1P SOCKET	FP 0278.5577.00	DUPONT CON	75377-001GEGURTET	0826.5071.01	
X77A	FP STIFTL.EISTE 36P.R2,54 PIN CONNECTOR	FP 0242.3600.00	BINDER	742-11-0179-00-36	0826.5071.01	
X77B	8-POLIG/8 PINS FP STIFTL.EISTE 36P.R2,54 PIN CONNECTOR	FP 0242.3600.00	BINDER	742-11-0179-00-36	0826.5071.01	
Z1	DT DAEMPFUNGSGLIED40DB/50 ATTENUATOR 40DB/50	0912.5269.00			0294.8983.00	
Z2	DT DAEMPFUNGSGLIED20DB/50 ATTENUATOR 20DB/50	0912.5252.00			0294.8983.00	
Z3	DT DAEMPFUNGSGLIED10DB/50 ATTENUATOR 10DB/50	0912.5246.00			0294.8983.00	
Z4	DT DAEMPFUNGSGLIED20DB/50 ATTENUATOR 20DB/50	0912.5252.00			0294.8983.00	
Z5	DT DAEMPFUNGSGLIED40DB/50 ATTENUATOR 40DB/50	0912.5269.00			0294.8983.00	
Z6	DT ANSCHLUSSLEITUNG/50 CONNECTION LINE	0915.0800.00			0294.8983.00	
Z7	BD UEBERSPANNUNGSSCHUTZ-X OVERVOLTAGE-PROTECTION	0915.4205.00			0294.8983.00	
Z11	LD PI-FILTER FILTER	1008.5850.00			0294.8983.00	
Z12	LD PI-FILTER FILTER	1008.5850.00			0294.8983.00	
MENP5	413 3PDA	AI	Datum Date	Schaltteilliste für Parts list for	Sachnummer Stock No.	Blatt-Nr. Page
	21	16.09.97	ZE EICHLITUNG (SMX)	0826.5065.01 SA	2-	

095.0028-0893

Ansicht und Leitungsführung Bauteilseite
View of tracks on component side

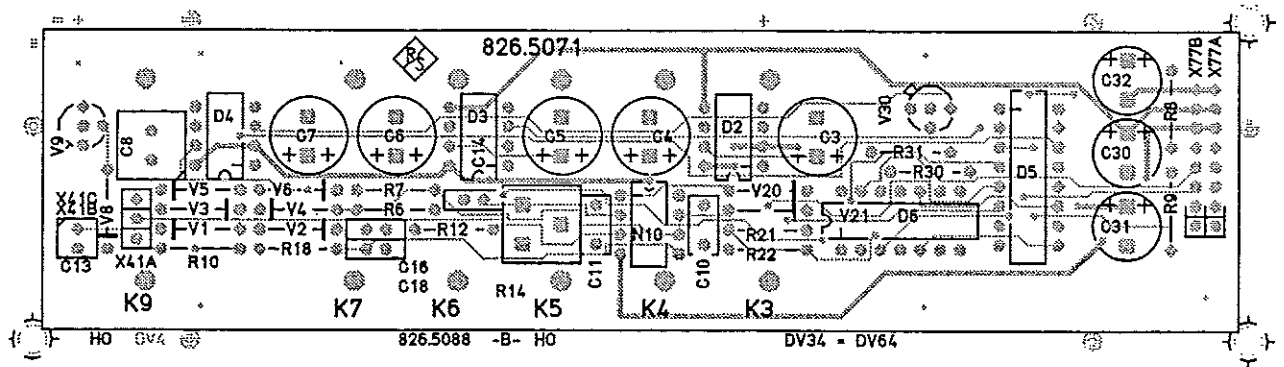

Ansicht und Leitungsführung Lötseite
View of tracks on solder side

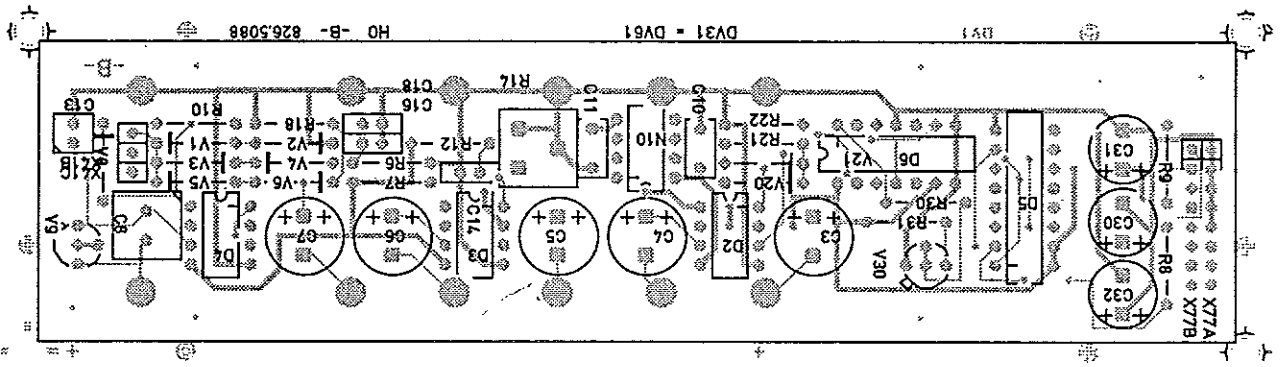

Für diese Unterlage behalten wir uns alle Rechte vor.



ACHTUNG: EGB!
Elektrostatisch gefährdete Bauelemente erfordern eine besondere Handhabung.
ATTENTION ESD!
Electrostatic sensitive devices require a special handling.

B	10.85	HOF	Maße ohne Toleranzangabe			Maßstab 1 : 1		
						Halbzeug, Werkstoff		
			1KSA	Tag	Name	Benennung		
			Bearb.	10.85	HOF	Ansteuerung/Eichleitung		Z
			Gepr					
			Norm					
			 ROHDE & SCHWARZ			Zeichn -Nr	826.5071.01	Blatt-Nr
And. Zust.	Anderungs-Mitteilung	Tag				Name		zu Gerät SM X
								v Bl

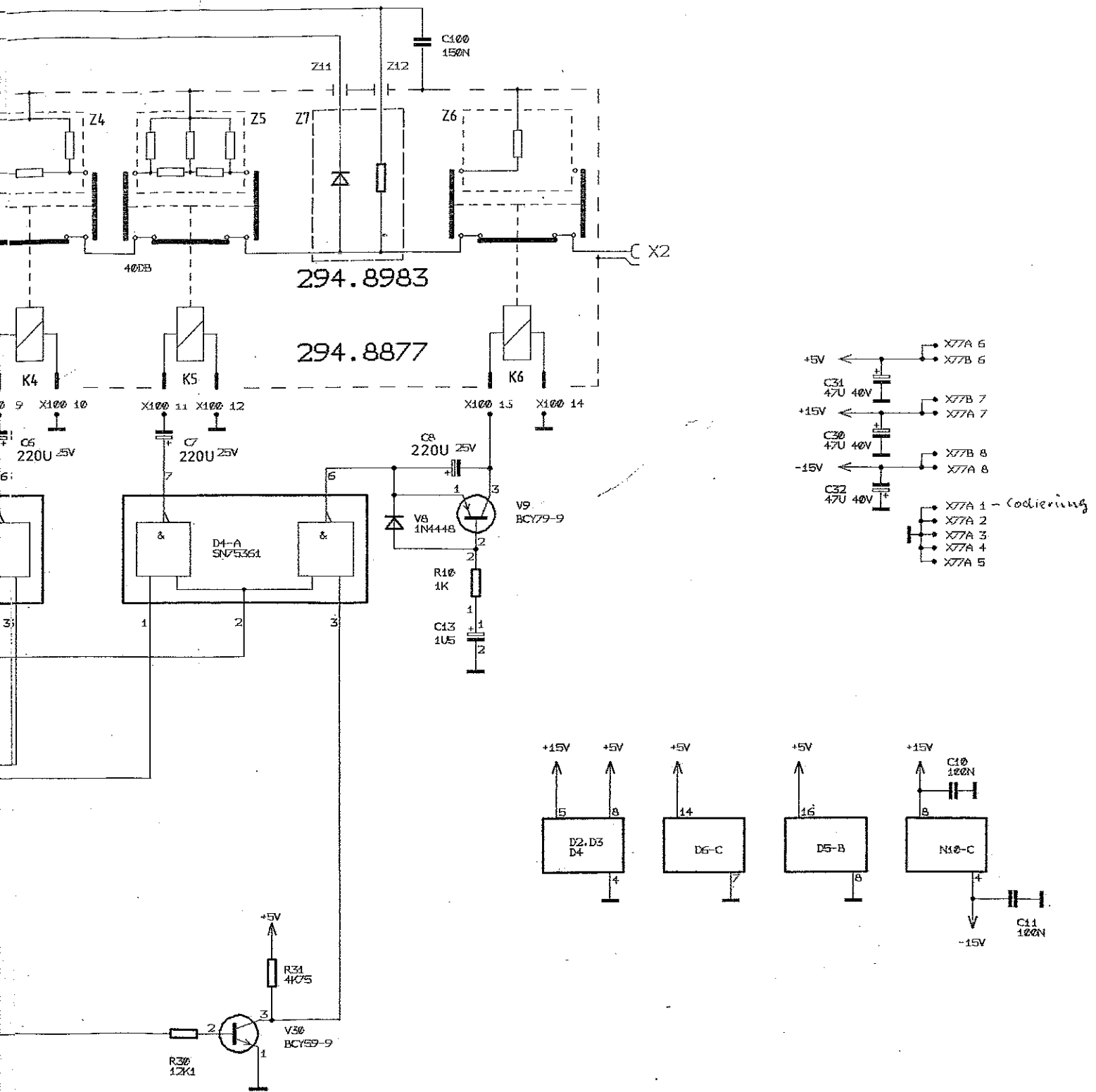

STROMLAUF GILT FUER VAR. 02
 CIRCUITDIAGRAM IS VALID FOR MOD. 02

B			LS	IKSA	Tag	Name	Benennung
C	32955	6.86	LS	Bearb.	29-10-85	LS	EICHLITUNG SMX ATTENUATOR SMX
D	35538	9.86	LS	Gepr.			
				Nam			
				Plott		3CDA	
							Zeichn.-Nr.
					ROHDE&SCHWARZ		826.5065 S
Aend. Zust.	Aenderung	Datum	Name	zu Gerät	SMX	Reg. t. V.	826.4517 V

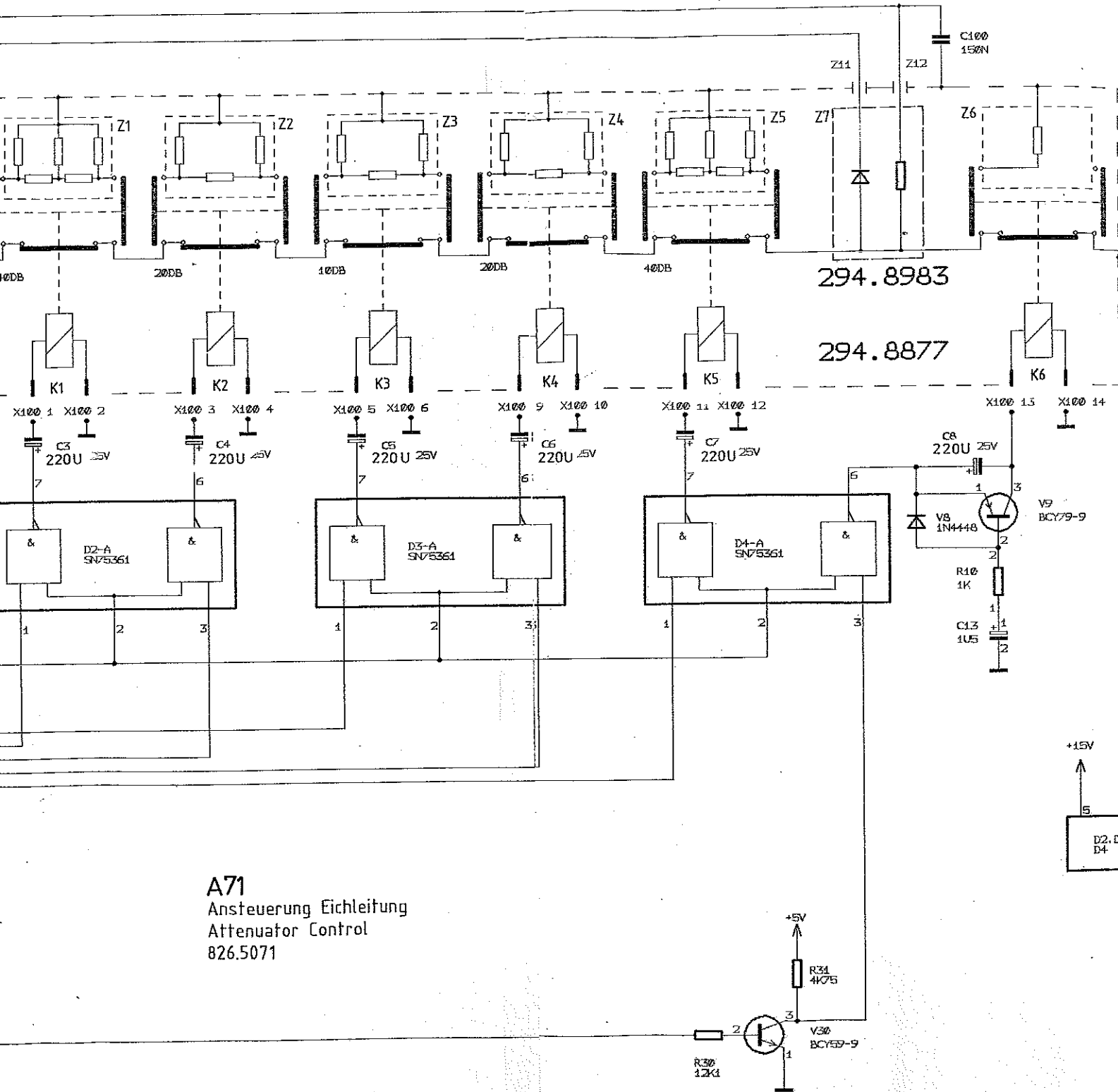

A71
 Ansteuerung Eichleitung
 Attenuator Control
 826.5071

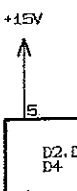

B	C	D	LS	1KSA	Tag	Name
	32955	6.86	LS	Bearb.	29-10-85	LS
	35538	9.86	LS	Gepr.		
				Norm		
				Platt		3CDA
Änd. Zust.	Aenderung	Datum	Name	zu Gepr.	SMX	

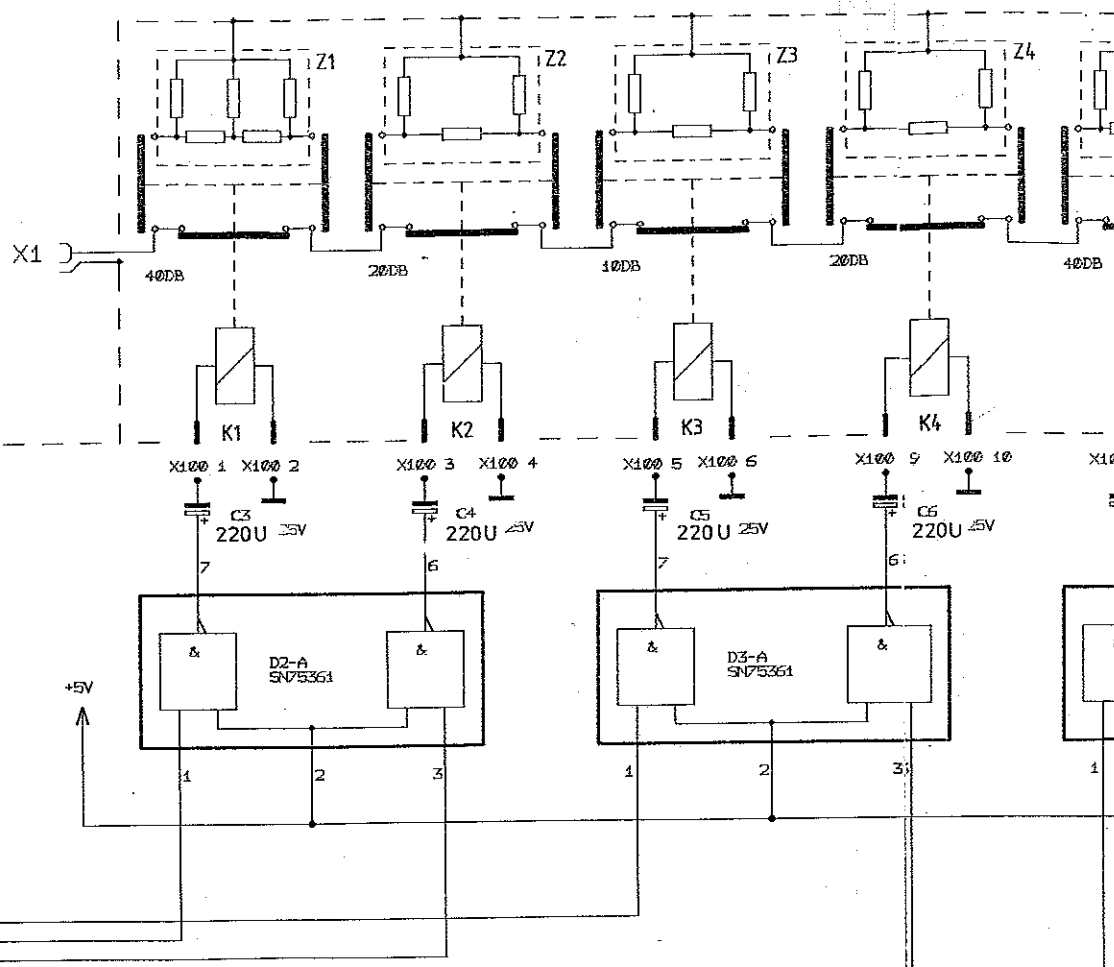

- 10
- 9
- 4
- 5
- 5
- 7
- 14
- 13
- 12
- 11

A71
 Ansteuerung Eicheitung
 Attenuator Control
 826.5071

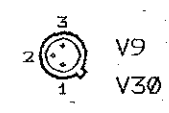
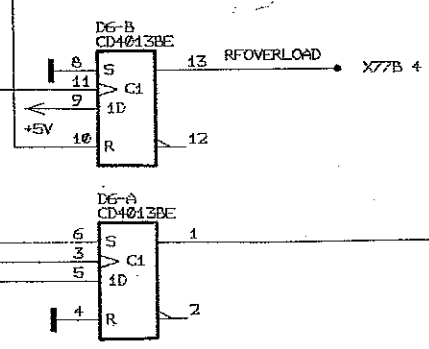

B	
C	32
D	35
Aend.	Aer
Zust.	

W41

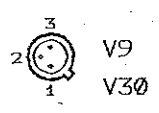
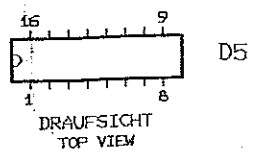
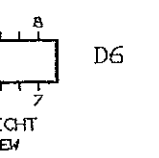
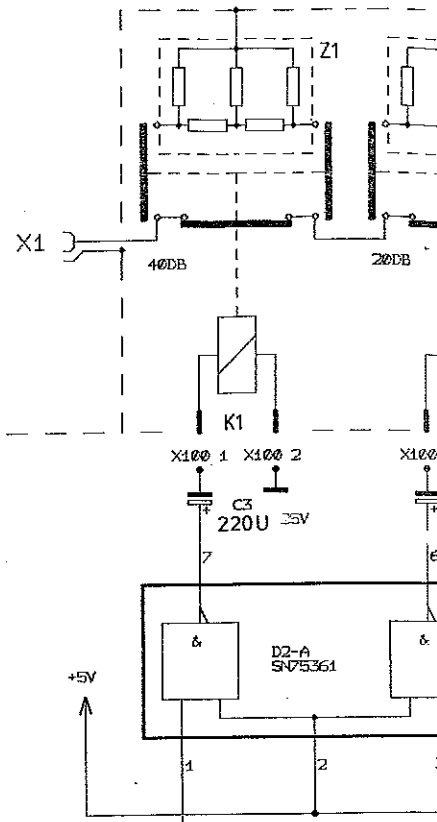
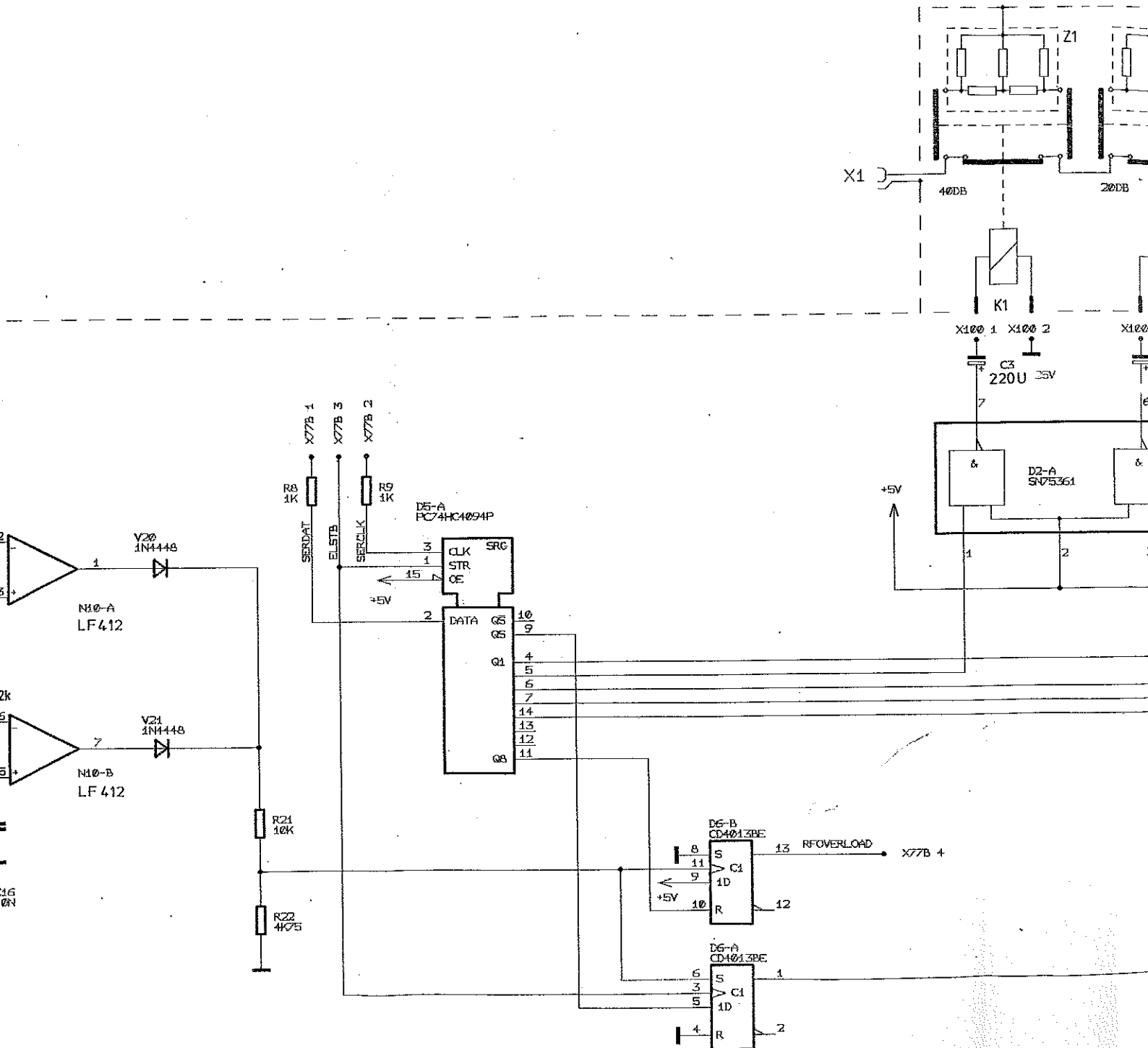

W41

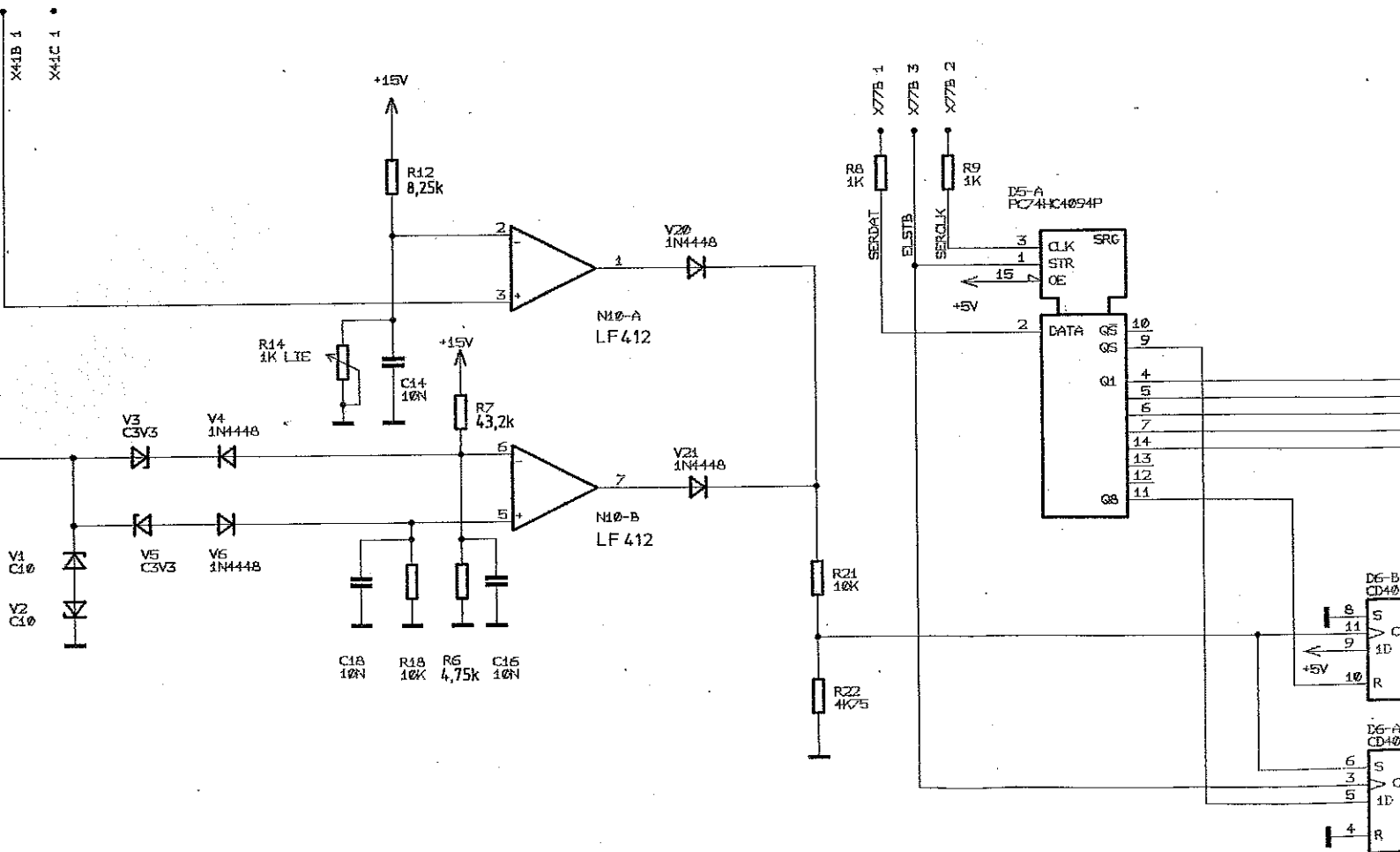

N10 D2
D3
D4

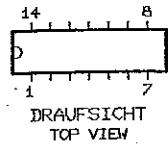

D6

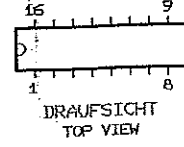

D5

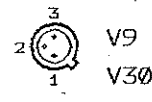

V9
V30

FÜR DIESE ZEICHNUNG BEZUG NEHMEN WIR UNS FÜR ALLE NEUERLE VON
 DIESE ZEICHNUNG IST EINGETRAGEN ABERAUSDRUCK, AENDERUNGEN KOENNEN NUR DURCH AENDERUNG DES DATENSATZES ERFOLGEN

1 2 3 4

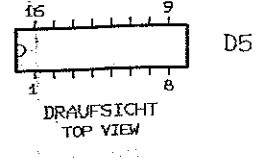
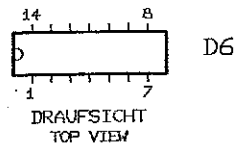
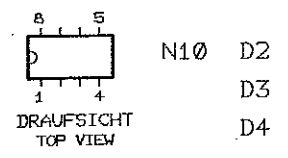
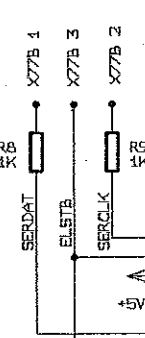
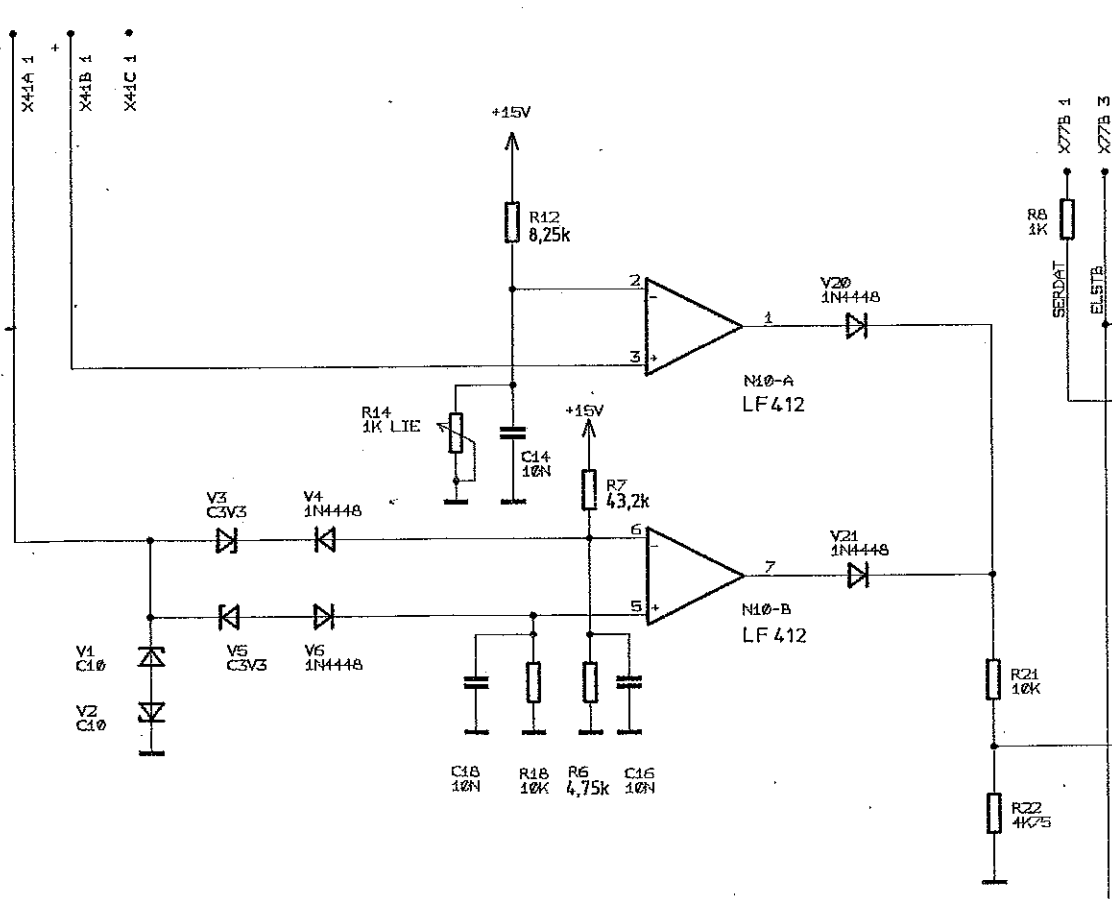
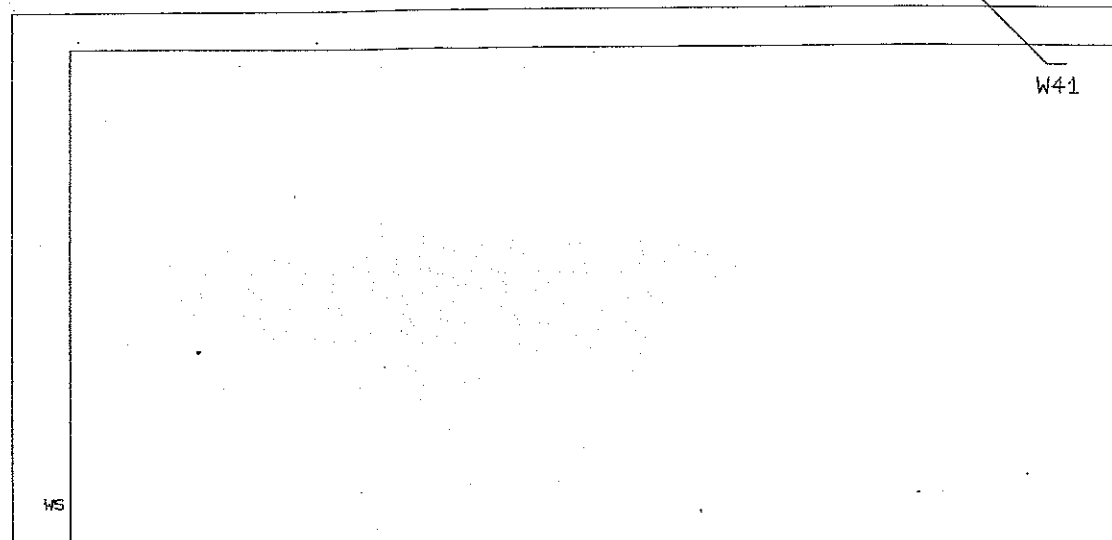

A

B

C

D

E

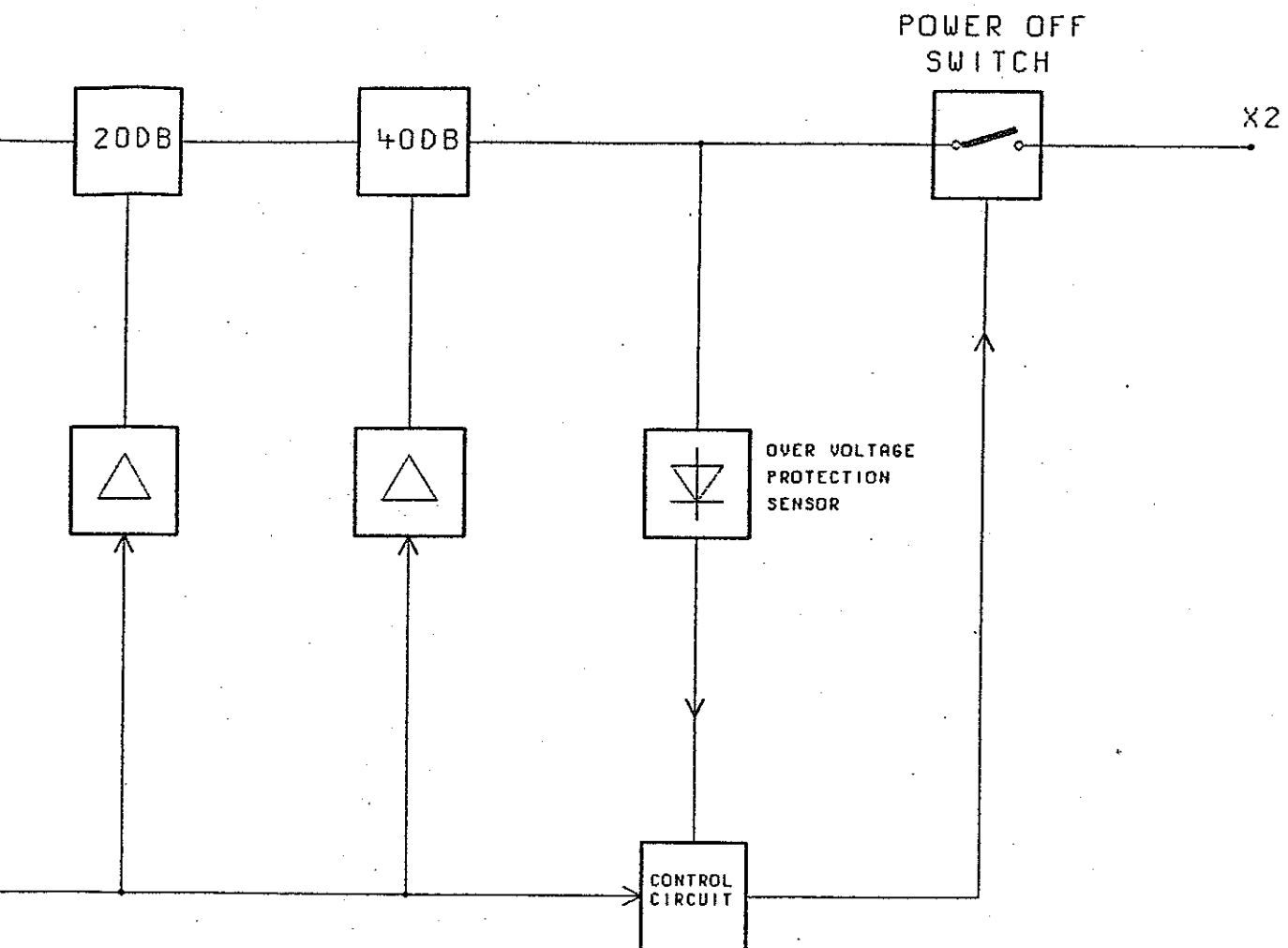

Bindende Angaben über Varianten, Trimmwerte, Bauteilwerte und nicht bestückte Bauteile siehe SA

For binding information on models, trimming and components values and nonfitted components see parts list.

DB/	48746	11.04.95	HM	MENP	TRG	NARE	BENENKUNG	
09		03.97	EI	BEARB.		HM	ZE EICHLITUNG ATTENUATOR	
				GEPR.	03.97	EI		
				NORM				
				PLOTT				
				 ROHDE & SCHWARZ			ZEICHN.-NR.	BLATT-NR.
REND. IND.	BERECKERUNGS- MITTEILUNG	DATUM	NAME			826.5065.015	1+	
				ZU GEHRET	SIX	PEG. I. V.	826.4517	EPSTE Z.

ATTENUATORS

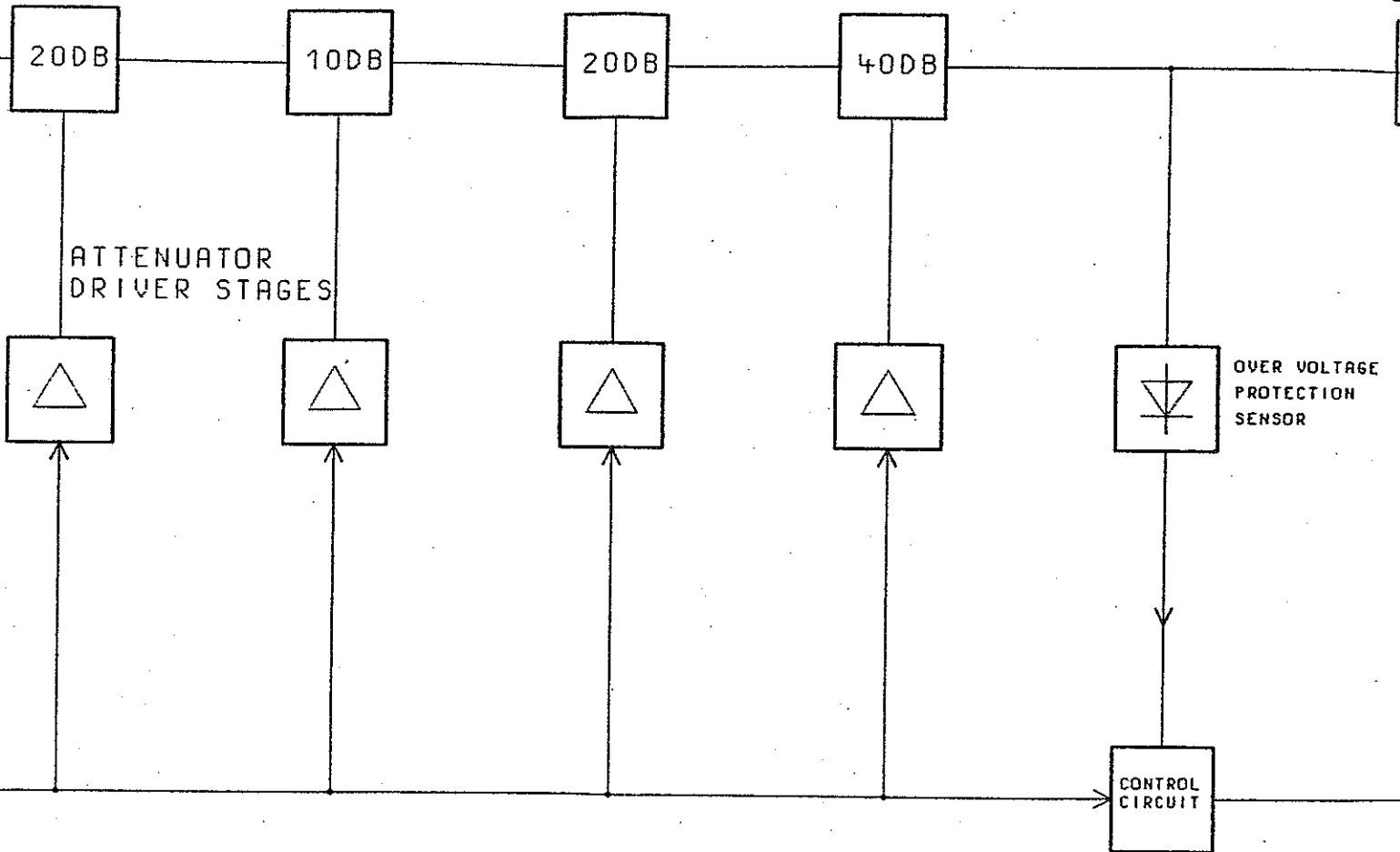

ACHTUNG: EGB!
ELEKTROSTATISCH GEFÄHRDETE
BAUELEMENTE ERFORDERN EINE
BESONDERE HANDHABUNG.
ATTENTION ESD!
ELECTROSTATIC SENSITIVE DEVICES
REQUIRE A SPECIAL HANDLING

DB/	48746	11.04.95	HM	MENP	TAG	NRRE	BENENNUNG
09		03.97	EI	BEARB.		HM	ZEICHN.-NR. ATTENUA
				GEPR.	03.97	EI	
				NORM			
				PLOTT			
REND. IND.	RENDERUNGS- MITTEILUNG	DATUM	NRRE	 ROHDE & SCHWARZ			8

ATTENUATORS

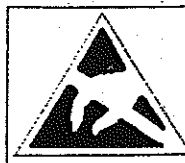
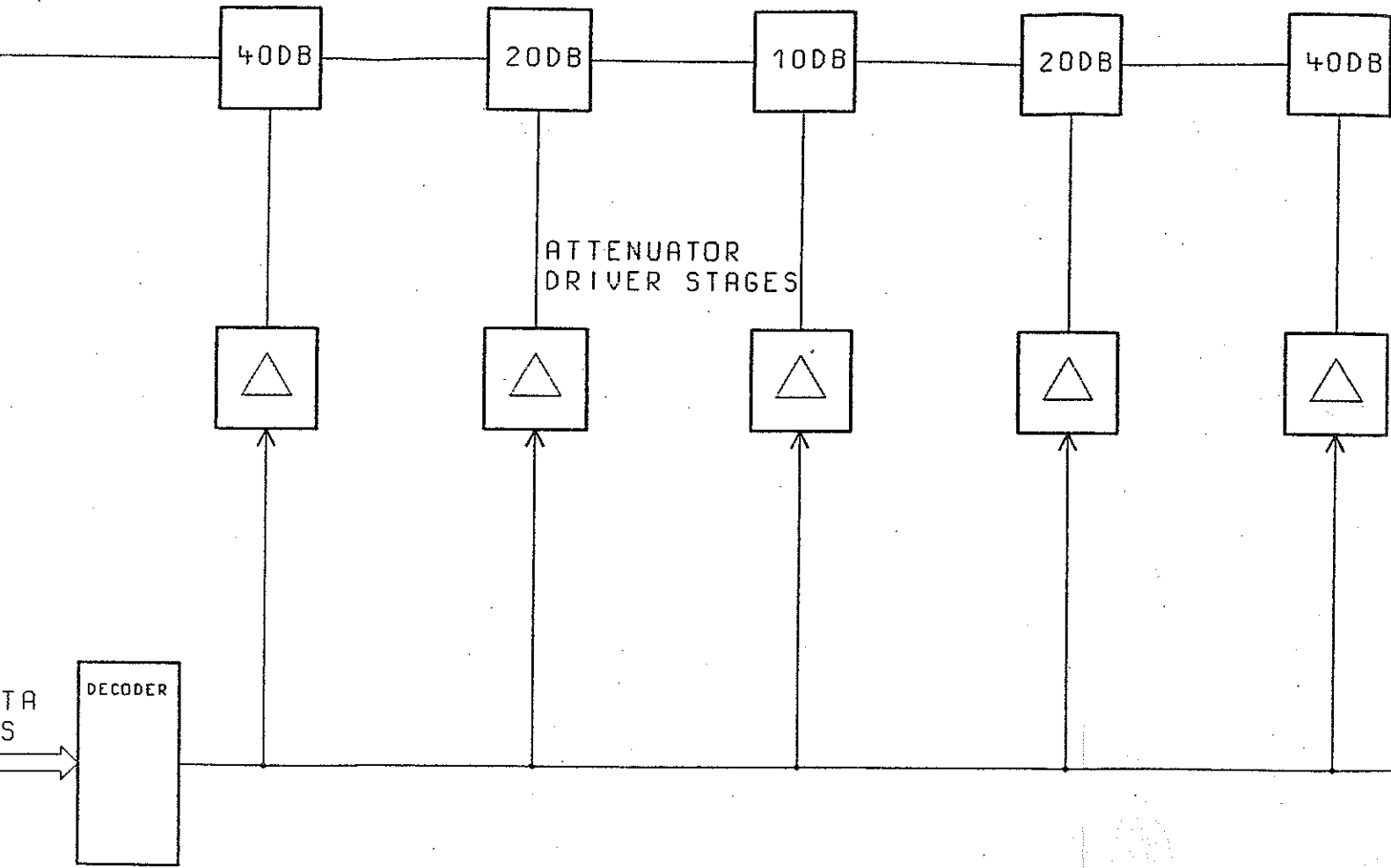

ACHTUNG: EGB!
 ELEKTROSTATISCH GEFÄHRDETE
 BAUELEMENTE ERFORDERN EINE
 BESONDERE HANDHABUNG.
 ATTENTION ESD!
 ELECTROSTATIC SENSITIVE DEVICES
 REQUIRE A SPECIAL HANDLING

08/	48746	11.04.95	HM
09		03.97	EI
RENO. IND.	ÄNDERUNGS- MITTEILUNG	DATUM	NAMEN

FÜR DIESE UNTERLAGE
NUR FÜR UNS ALLE RECHTE VOR

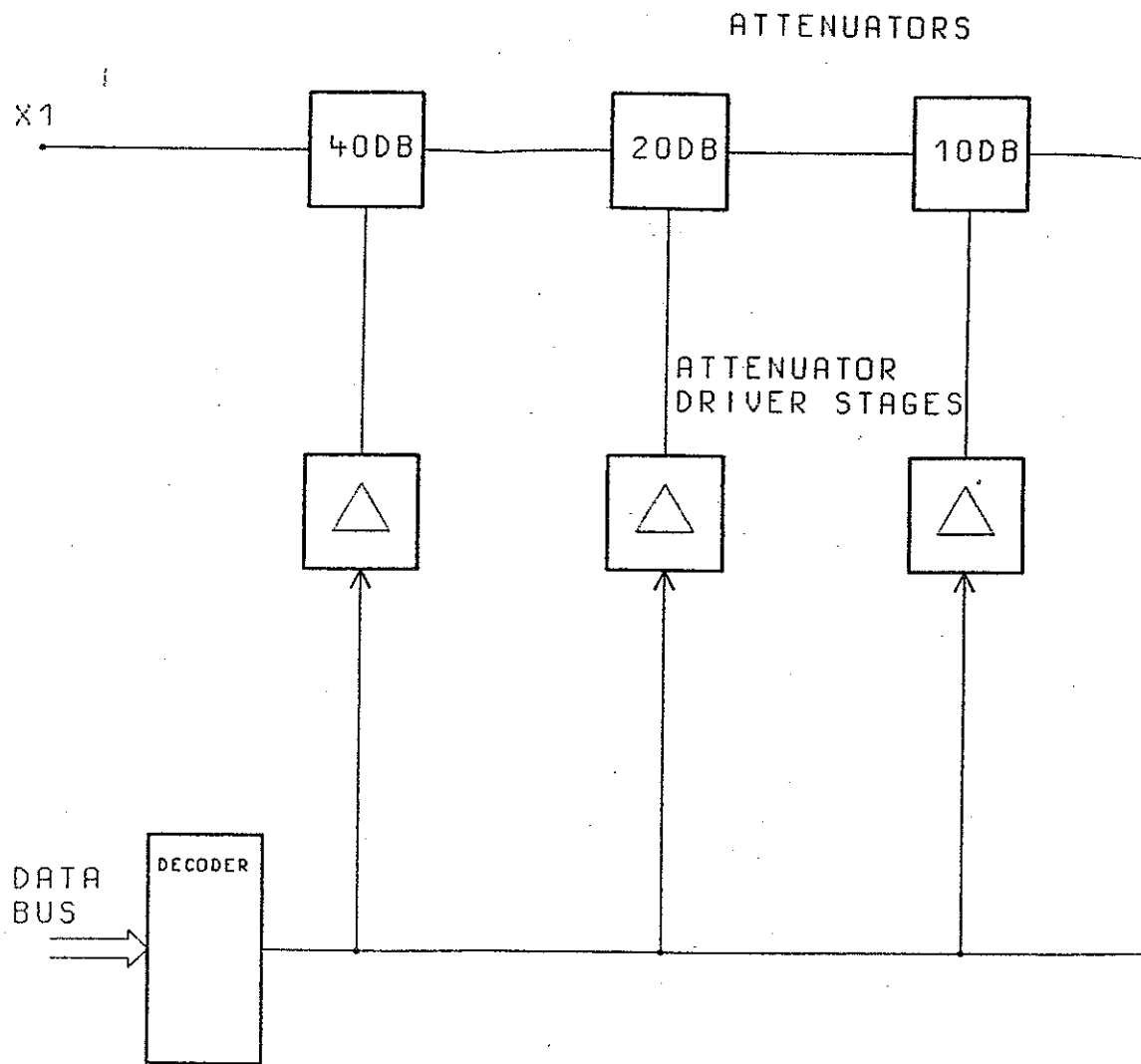

ACHTUNG: EGB!
ELEKTROSTATISCH GEFÄHRDET
BAUELEMENTE ERFORDERN EINE
BESONDERE HANDHABUNG.
ATTENTION ESD!
ELECTROSTATIC SENSITIVE DEVS
REQUIRE A SPECIAL HANDLING





ROHDE & SCHWARZ

SERVICEUNTERLAGEN

Eichleitung 2 GHz

0801.1108.01

Inhaltsverzeichnis

7 Prüfen und Instandsetzen der Baugruppe	5
7.1 Funktionsbeschreibung	5
7.1.1 Eichleitung mit integriertem Überspannungsschutz.....	5
7.1.2 Ansteuerung der Eichleitung.....	5
7.2 Meßgeräte und Hilfsmittel	6
7.3 Fehlersuche	6
7.3.1 Ansteuercode.....	6
7.3.2 Ansteuerpuls der Dämpfungsglieder.....	7
7.4 Prüfen und Abgleich	7
7.4.1 Prüfen der Dämpfungsglieder und der Ansteuerdruckschaltung.....	7
7.4.2 Prüfen des Überspannungsschutzes.....	7
7.4.2.1 Statische Prüfung.....	7
7.4.2.2 Prüfung bei Wechselspannung (nur VAR04).....	8
7.4.2.3 Prüfung bei Gleichspannung (nur VAR04).....	8
7.4.2.4 Prüfung und Abgleich bei Wechselspannung (nur VAR02).....	8
7.4.2.5 Prüfung bei Gleichspannung (nur VAR02).....	8
7.4.3 Schnittstellen.....	9

Schaltteilliste
Koordinatenliste
Stromlauf
Bestückungsplan

ACHTUNG!!!

Die Baugruppe darf nicht geöffnet werden, da sonst der Garantieanspruch erlischt und ein Neuabgleich durchgeführt werden muß.

Für SMY ohne Option SMY-B40 ist für diese Baugruppe die Variante 02 erforderlich.

Für SMY mit Option SMY-B40 ist für diese Baugruppe die Variante 04 erforderlich.

7.1 Funktionsbeschreibung

(Siehe hierzu Stromlauf und Blockschaltbild 0801.1108.01S)

7.1.1 Eichleitung mit integriertem Überspannungsschutz

Die Eichleitung ist zwischen das Ausgangsteil (bzw. der Baugruppe Powermodul bei Geräten mit Option SMY-B40) und den Geräteausgang geschaltet. Mit ihr kann das Signal um 135dB in 5dB-Stufen abgesenkt werden. Kleinere Pegelsprünge werden mit Hilfe der elektronischen Pegelregelung eingestellt. Die Eichleitung enthält sechs Dämpfungsglieder mit den Werten 5, 10, 2*20 und 2*40dB, ein Überspannungsschutzsubstrat und ein 50 Ohm Abschlußwiderstand. Die Dämpfungsglieder können durch jeweils eine Kontaktgruppe, die aus drei Einzelkontakten besteht, eingeschaltet oder überbrückt werden. Jede dieser Kontaktgruppen wird von einer Wippe betätigt, die von einer Magnetspule angetrieben und durch einen Permanentmagneten in der Endlage gehalten wird.

Hinter den Dämpfungsgliedern sitzt auf der Eichleitungsgrundplatte in Richtung Geräteausgang das Überspannungsschutzsubstrat und anschließend der RF-OFF-Schalter. Das Überspannungsschutzsubstrat erkennt hohe DC-Spannungen und HF-Pegel, welche an die Ausgangsbuchse X1 angelegt werden und betätigt den RF-OFF-Schalter. Der RF-OFF-Schalter kann aber auch vom Rechner über die Software bedient werden.

7.1.2 Ansteuerung der Eichleitung

Die Dämpfungseinstellung erfolgt durch serielle Datenübertragung (siehe 7.3.1). Die Ansteuerbits werden über die Datenleitungen (X77.B1 SERDAT) mit dem Clock (X77.B2 SERCLK) in das Schieberegister (D5) auf der Eichleitungsansteuerdruckschaltung geschoben. Mit dem Strobe (X77.B3 ELSTB) werden die Ausgänge des Schieberegisters gesetzt und die gewünschte Dämpfung eingestellt. Die Ansteuerung der Magnetspulen der Kontaktgruppen erfolgt über die Leistungsgatter D1 bis D4.

Hohe HF- und DC-Spannungen an der Ausgangsbuchse werden durch Spitzenwertgleichrichtdioden erkannt. Wird eine Überspannung erkannt, sprechen die Komperatoren N10 a,b an und setzen das Flip-Flop D6, das über V8 und D4 direkt den RF-OFF-Schalter betätigt.

Während der Ansprechzeit des RF-OFF-Schalters schließen die Pindioden auf dem Überspannungsschutzsubstrat die Überspannung kurz. Durch die beiden Monoflops V33 und V34 wird den Pindioden im Überlastfall ein hoher DC-Strom eingeprägt, wodurch diese niederohmig werden. Dem Rechner wird der Überlastfall über die Interruptleitung (X77.B4) mitgeteilt. Dieser Interrupt wird dann rückgesetzt, wenn der RF-OFF-Schalter zusätzlich vom Rechner über Software betätigt wird. Der RF-OFF-Schalter kann von Hand über die Tastenfolge 'LEVEL ON' wieder geschlossen werden.

7.2 Meßgeräte und Hilfsmittel

1. Ohmmeter (Meßbereich bis 2M Ω)
2. Leistungsmeßsender (z.B. SMGL)
3. Gleichspannungsnetzgerät für $\pm 15V$
4. Speicheroszilloskop

7.3 Fehlersuche

7.3.1 Ansteuercode

Läßt sich am Gerät ein gewünschter Ausgangspegel nicht einstellen, so kann am Schieberegisterausgang D5 der ordnungsgemäße Ansteuercode der einzelnen Dämpfungsglieder überprüft werden (siehe Tabelle 7.3.1).

Tabelle 7.3.1 für 02 im CW-Betrieb

Ansteuercode am Schieberegister D5 (74HC 4094)

--	--	--	--	--	--	--	--	--

'1' = 5V, '0' = 0V

Pegeleinstellung		Pin4	5	6	7	14	13	11,9
mit	ohne	Q0	Q1	Q2	Q3	Q4	Q5	Q7, Q8
Option SMY-B40		40 dB	20 dB	5 dB	10 dB	20 dB	40 dB	RF-OFF
19 dBm	13 dBm	1	1	1	1	1	1	0
14 dBm	8 dBm	1	1	0	1	1	1	0
9 dBm	3 dBm	1	1	1	1	0	1	0
-1 dBm	-7 dBm	1	1	1	0	1	1	0
-21 dBm	-27 dBm	1	1	1	1	1	0	0
-61 dBm	-67 dBm	0	1	1	1	1	0	0
-101 dBm	-107 dBm	0	0	1	0	1	0	0
-114 dBm	-122 dBm	0	0	0	0	0	0	0

'1' = 5V, '0' = 0V

7.3.2 Ansteuerpuls der Dämpfungsglieder

Entspricht der Puls an den Magnetspulen D1 bis D4 nicht der in Bild 7.3.2 gezeichneten Form, so liegt ein auftretender Dämpfungsfehler an der Ansteuerdruckschaltung und nicht an den Dämpfungsgliedern mit den zugehörigen Kontaktgruppen vor.



Bild 7.3.2

7.4 Prüfen und Abgleich

7.4.1 Prüfen der Dämpfungsglieder und der Ansteuerdruckschaltung

Hierzu ist zu verfahren wie in Kapitel 5.2.6 der Wartungsunterlage im Betriebshandbuch beschrieben ist.

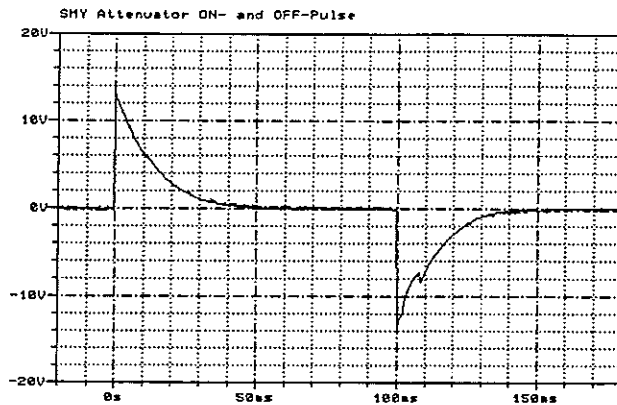
7.4.2 Prüfen des Überspannungsschutzes

7.4.2.1 Statische Prüfung

- Stecker X41 von der Eichleitungsansteuerdruckschaltung abziehen.
- Einen Ausgangspegel von -122 dBm einstellen.

Mit einem Ohmmeter können nun die Dioden des Überspannungsschutzes in Sperr- und Durchlaßrichtung gemessen werden. In Sperrrichtung muß der Widerstand sehr groß sein.

- Die Messung erfolgt zwischen der Ausgangsbuchse X1 und dem Durchführungsfilter Z9 für die erste Diode, am Durchführungsfilter Z10 für die zweite.

7.4.2.2 Prüfung bei Wechselspannung (nur VAR04)

- Einen Ausgangspegel von -122 dBm einstellen.
 - Einen Leistungsmeßsender mit dem RF-Ausgang des SMY verbinden und eine RF von 25 MHz einstellen.
- _ Der RF-OFF-Schalter muß bei 30 ... 33 dBm ansprechen

7.4.2.3 Prüfung bei Gleichspannung (nur VAR04)

- An die RF-Ausgangsbuchse X1 des Geräts eine DC-Spannung aus einer Gleichspannungsquelle anlegen.
- _ Der RF-OFF-Schalter muß bei Spannungen an der N-Buchse von $\pm(7.5 \text{ V} \dots 8.5 \text{ V})$ ansprechen.

Ein Rücksetzen des RF-OFF-Schalters erfolgt mit der Tastenkombination 'LEVEL ON'.

7.4.2.4 Prüfung und Abgleich bei Wechselspannung (nur VAR02)

- Einen Ausgangspegel von -122 dBm einstellen.
 - Einen Leistungsmeßsender mit dem RF-Ausgang des SMY verbinden und eine RF von 25 MHz einstellen.
- _ Der RF-OFF-Schalter muß bei 27.5 dBm ± 1.5 dB ansprechen, ein Abgleich kann mit dem Potentiometer R30 erfolgen.

7.4.2.5 Prüfung bei Gleichspannung (nur VAR02)

- An die RF-Ausgangsbuchse X1 des Geräts eine DC-Spannung aus einer Gleichspannungsquelle anlegen.
- _ Der RF-OFF-Schalter muß bei Spannungen von $\pm(5 \dots 7 \text{ V})$ ansprechen.

Ein Rücksetzen des RF-OFF-Schalters erfolgt mit der Tastenkombination 'LEVEL ON'.



ROHDE & SCHWARZ

SERVICE INSTRUCTIONS

Attenuator 2 GHz

801.1108.01

Contents

7 Testing and Repair of the Module.....	5
7.1 Function Description.....	5
7.1.1 Attenuator with Overvoltage Protection.....	5
7.1.2 Control of the Attenuator.....	5
7.2 Test Instruments and Utilities.....	6
7.3 Troubleshooting.....	6
7.3.1 Control Code.....	6
7.3.2 Control Pulse of the Attenuator Pads.....	6
7.4 Testing and Adjustment.....	7
7.4.1 Testing the Attenuator Pads and the Control P.C.B....	7
7.4.2 Testing the Overvoltage Protection.....	7
7.4.2.1 Static Test.....	7
7.4.2.2 Testing with AC Supply (VAR04 only).....	7
7.4.2.3 Testing with DC Voltage Supply (VAR04 only) ..	8
7.4.2.4 Testing and Adjustment with AC Supply (VAR02 only).....	8
7.4.2.5 Testing with DC Voltage Supply (VAR02 only) ..	8
7.4.3 Interfaces.....	8

Parts list
List of coordinates
Circuit diagram
Components layout diagram

CAUTION!!!

Do not open the module, since otherwise the warranty expires and re-adjustment is required.

For instruments without option SMY-B40, this module with VAR02 is necessary.

For instruments with option SMY-B40, this module with VAR04 is necessary.

7.1 Function Description

(Cf. circuit diagram and block diagram 0801.1108.01S)

7.1.1 Attenuator with Overvoltage Protection

The attenuator is connected between the output module (the power module for instruments with option SMY-B40, respectively) and the instrument output. It is used to attenuate the signal by 135 dB in steps of 5 dB. Smaller level jumps are set via the electronic level control. The attenuator consists of six attenuator pads of 5, 10, 2*20 and 2*40 dB, an overvoltage-protection substrate and a 50-Ohm terminator. The attenuator pads can be switched on or bypassed by means of one contact group each, which consists of three individual contacts. Each of these contact groups is actuated by a rocker, which is driven by a magnetic coil and kept in end position by a permanent magnet.

The overvoltage-protection substrate and the RF-OFF switch are accommodated on the attenuator motherboard subsequent to the attenuator pads. The overvoltage-protection substrate detects high dc voltages and RF levels which are applied to the output socket X1 and actuates the RF-OFF switch. The RF-OFF switch may also be software-controlled via the controller.

7.1.2 Control of the Attenuator

The attenuation is set via serial data transmission (cf. 7.3.1). The control bits are clocked into the shift register (D5) on the attenuator control pcb via the data lines (X77.B1 SERDAT) using the clock X77.B2 SERCLK. The strobe (X77.B3 ELSTB) sets the outputs of the shift registers and the desired attenuation. The magnetic coils of the contact groups are controlled via the power gates D1 to D4.

Peak-responding rectifier diodes detect high RF and dc voltages at the output socket. If an overvoltage has been detected, the comparators N10 a,b respond and set the flip-flop D6, which directly actuates the RF-OFF switch via V8 and D4. During the response time of the RF-OFF switch, the pin diodes on the overvoltage-protection substrate short-circuit the overvoltage. In case of overvoltage, the pin diodes are impressed by a high dc current by means of the two monoflops V33 and V34, the pin diodes thus becoming low-impedance. The information on overload is passed to the controller via the interrupt line (X77.B4). This interrupt is reset if the RF-OFF switch is additionally software-controlled. The RF-OFF switch can be reset manually via the key sequence 'LEVEL ON'.

7.2 Test Instruments and Utilities

1. Ohmmeter (Measuring range up to 2 MOhms)
2. Power generator (e.g., SMGL)
3. DC power supply for ± 15 V
4. Storage oscilloscope

7.3 Troubleshooting

7.3.1 Control Code

If a desired output level can not be set on the instrument, check at the shift register D5 whether the control code of the individual attenuator pads is correct (see table 7.3.1).

Table 7.3.1 for SMY02 (CW mode):

Control code at shift register D5 (74HC 4094)

Level setting		Pin4	5	6	7	14	13	11,9
with	without	Q0	Q1	Q2	Q3	Q4	Q5	Q7, Q8
option	SMY-B40	40 dB	20 dB	5 dB	10 dB	20 dB	40 dB	RF-OFF
19 dBm	13 dBm	1	1	1	1	1	1	0
14 dBm	8 dBm	1	1	0	1	1	1	0
9 dBm	3 dBm	1	1	1	1	0	1	0
-1 dBm	-7 dBm	1	1	1	0	1	1	0
-21 dBm	-27 dBm	1	1	1	1	1	0	0
-61 dBm	-67 dBm	0	1	1	1	1	0	0
-101 dBm	-107 dBm	0	0	1	0	1	0	0
-114 dBm	-122 dBm	0	0	0	0	0	0	0

'1' = 5V, '0' = 0V

7.3.2 Control Pulse of the Attenuator Pads

If the pulse at the magnetic coils D1 to D4 does not correspond to the form illustrated in fig. 7.3.2, an error occurred on the control p.c.b., the attenuator pads with the associate contact groups are, however, o.k.

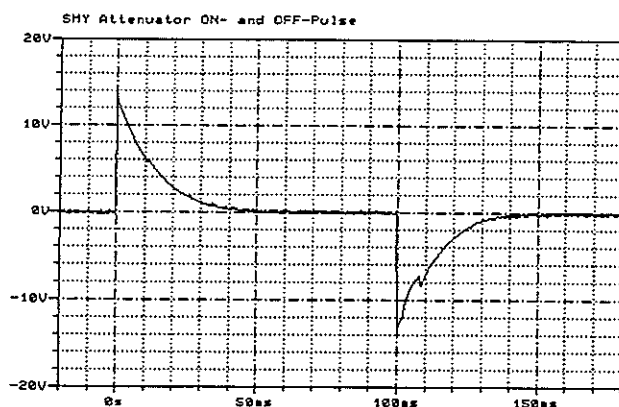

Fig. 7.3.2

7.4 Testing and Adjustment

7.4.1 Testing the Attenuator Pads and the Control P.C.B.

Proceed as described in Section 5.2.6 of the maintenance instructions given in the operating manual.

7.4.2 Testing the Overvoltage Protection

7.4.2.1 Static Test

- Withdraw connector X41 from the attenuator p.c.b.
- Set output level to -122dBm.

The overvoltage-protection diodes can be measured in forward and reverse direction using an ohmmeter. The impedance must be very high when the diodes are reverse-biased.

- The measurement is performed between the output socket X1 and the lead-through filter Z9 for the first diode, lead-through filter Z10 for the second diode.

7.4.2.2 Testing with AC Supply (VAR04 only)

- Set output level to -122 dBm.
- Connect a signal generator to the RF output of the SMY and set an RF of 25 MHz.

— The RF-OFF switch must respond with 30 ... 33 dBm.

7.4.2.3 Testing with DC Voltage Supply (VAR04 only)

- Apply a dc voltage from a dc power supply to the RF output socket X1 of the instrument.

_ The RF-OFF switch must respond for voltages between \pm (7.5 to 8.5 V) at the N socket.

The RF-OFF switch is reset using the key combination 'LEVEL ON'.

7.4.2.4 Testing and Adjustment with AC Supply (VAR02 only)

- Set output level to -122 dBm.
- Connect a signal generator to the RF output of the SMY and set an RF of 25 MHz.

_ The RF-OFF switch must respond with 27.5 dBm \pm 1.5dB, it can be adjusted using the potentiometer R30.

7.4.2.5 Testing with DC Voltage Supply (VAR02 only)

- Apply a dc voltage from a dc power supply to the RF output socket X1 of the instrument.

_ The RF-OFF switch must respond with voltages \pm (5 ... 7 V).

The RF-OFF switch is reset using the key combination 'LEVEL ON'.

7.4.3 Interfaces

Pin	Name	Input/Output	Origin/Dest.	Specified range	Signal description
X77.A1	GND				
X77.B1	SERDAT	Input	Controller X3.4	TTL-HCT	Serial data
X77.A2	GND				
X77.B2	SERCLK	Input	Controller X3.2	TTL-HCT	Clock signal
X77.A3	GND				
X77.B3	ELSTB	Input	Controller X3.19	TTL-HCT	Strobe signal
X77.A4	GND				
X77.B4	HFOVERLOAD	Output	Controller X3.22	TTL-HCT	Overload interrupt
X77.A5	GND				
X77.B5	not used				
X77.A6	VA5-P	Input	Power supply X21	5+4.5 to +5.3 V 42 \pm 8mA	+5.1 V supply
X77.B6	"	"	"	"	"
X77.A7	VA15-P	"	" X21.13	+14.9 to +15.6V 20 \pm 4mA	+15 V supply
X77.B7	"	"	"	"	"
X77.A8	VA15-N	"	" X21.19	-15.5 to -14.4 V 3 \pm .5 V	-15 V supply
X77.B8	"	"	"	"	"
X1		Input	Output module		
X2		Output	RF socket		



ROHDE & SCHWARZ

Schaltteillisten
Stromläufe
Bestückungspläne
Part lists
Circuit diagrams
Components plans
Listes des pièces détachées
Schémas de Circuit
Plans des composants

Für diese Unterlage behalten wir uns alle Rechte vor.

Kennz. Comp. No.	Benennung Designation	Sachnummer Stock No.	Hersteller Manufacturer	Bezeichnung Designation	enthalten in contained in
	XX VARIANTENERKLAERUNG IDENTIFICATION OF MODELS VAR 02 = GRUNDAUSFUEHRUNG MOD 02 = BASIC MODEL ERSETZT/REPLACE VAR 00/MOD 00 VAR 04 = SMY12/44/45+B40 MOD 04 = SMY12/44/45+B40				
A90	ED ANSTEUERUNG EICHLITG. ATTENUATOR CONTROL NUR VAR/ONLY MOD: 02 ZUEGH.STROML./CIRC.DIAGR. 801.1108 S	0801.1120.02			
A90	ED ANSTEUERUNG EICHLITG. NUR VAR/ONLY MOD: 04 ZUEGH.STROML./CIRC.DIAGR. 801.1108S GS UNGEPRUEFT.AK "C"	0801.1120.04			
C1	CE 220UF+-20%35V RM5 ELECTROLYTIC CAPACITOR	CE 0008.7904.00	PANASONIC	ECA-1VFG221BQ	0801.1120.01
C7	CE 100UF+-20%35V RM5 ELECTROLYTIC CAPACITOR	0008.7510.00	PHILIPS_CO	2222 116 90042	0801.1120.01
C8	CE 47UF+-20%63V RM5 ELECTROLYTIC CAPACITOR	0008.7440.00	PHILIPS_CO	2222 116 90112	0801.1120.01
C9	CE 47UF+-20%63V RM5 ELECTROLYTIC CAPACITOR	0008.7440.00	PHILIPS_CO	2222 116 90112	0801.1120.01
C10	CK 100NF+-5%63VRD2,5H7MKT CAPACITOR	CK 0099.2930.00	ROEDERSTEI	MKT 1826-410-06-4W	0801.1120.01
C11	CE 1,5UF+-20%25V 5X 4X 7 ELECTROLYTIC CAPACITOR	CE 0087.9334.00	KEMET	T340 A155M025 AS	0801.1120.01
C15	CC 10NF-20+50%7X8R4000 CAPACITOR	CC 0087.7525.00	VALVO	2222 640 51103	0801.1120.01
C17	CC 10NF-20+50%7X8R4000 CAPACITOR	CC 0087.7525.00	VALVO	2222 640 51103	0801.1120.01
C18	CK 100NF+-5%63VRD2,5H7MKT CAPACITOR	CK 0099.2930.00	ROEDERSTEI	MKT 1826-410-06-4W	0801.1120.01
C19	CC 3,3NF+-10%6X7R2000 CAPACITOR	CC 0087.7083.00	PHILIPS_CO	2222 630 5(1)1332	0801.1120.01
C20	CK 33NF+-5%63V RD2,5H7MKT CAPACITOR	CK 0099.2900.00	ROEDERSTEI	MKT 1826-333/014	0801.1120.01
C20	NUR VAR/ONLY MOD: 02 CK 3,3NF +-1% 63V RM5 KP POLYPROPYLENE CAPACITOR	CK 0007.7623.00	ROEDERSTEI	KP1830-233 06 1 3 W	0801.1120.01
C20	NUR VAR/ONLY MOD: 04				
C30	CE 47UF+-20%63V RM5 ELECTROLYTIC CAPACITOR	0008.7440.00	PHILIPS_CO	2222 116 90112	0801.1120.01
C31	CE 47UF+-20%63V RM5 ELECTROLYTIC CAPACITOR	0008.7440.00	PHILIPS_CO	2222 116 90112	0801.1120.01
C35	CC 680NF+-10% 50V8K1200VI CAPACITOR	0082.7785.00	UNION_CARB	CKR 06 BX 684K	0801.1120.01
C36	CC 680NF+-10% 50V8K1200VI CAPACITOR	0082.7785.00	UNION_CARB	CKR 06 BX 684K	0801.1120.01
D1	BJ SN75361AP 2XTTL/MOS-LC LEVEL CONVERTER	BJ 0294.8490.00	NSC	DS75361N	0801.1120.01
D2	BJ SN75361AP 2XTTL/MOS-LC LEVEL CONVERTER	BJ 0294.8490.00	NSC	DS75361N	0801.1120.01
D4					
D5	BL PC74HC4094P 8ST.SH.REG 8ST.SHIFT A.STDRE REGIST.	0099.9711.00	PHILIPS_SE	(PC)74HC4094N(P)	0801.1120.01
D6	BL CD4013BE 2XD- FLIPFL FLIPFLOP	0086.7021.00	RCA	CD4013BE	0801.1120.01
K1	LD ELEKTROMAGNET (EICHL.) ELECTROMAGNET	0294.8425.00			0294.8925.00
K6					
K9	LD ELEKTROMAGNET (EICHL.) ELECTROMAGNET	0294.8425.00			0294.8925.00
N10	BO LF412CN 2XFET OPAMP OPERATIONAL AMPLIFIER	0356.0521.00	NSC	LF412CN	0801.1120.01
N20	BS TL604CP 2X ANALOGSCH ANALOG SWITCH	BJ 0300.6199.00	TEXAS	TL604CP	0801.1120.01
R5	RL 0,60W 1KOHM+-1%TK50 RESISTOR	RL 0082.2160.00	RESISTA	MK2	0801.1120.01
R6	RL 0,60W 1KOHM+-1%TK50 RESISTOR	RL 0082.2160.00	RESISTA	MK2	0801.1120.01
R7	RL 0,40W 1,00KOHM+-1%TK50 RESISTOR	RL 0092.1444.00	RESISTA	MK1 1K00 1% TK50	0801.1120.01

095.0026-0693

MENP5	413 3PUA	Äl	Datum Date	Schaltteilliste für Parts list for	Sachnummer Stock No.	Blatt-Nr. Page
	13	16.09.97	ZE EICHLITUNG (SMG/SMH)	0801.1108.01 SA	1+	

Für diese Unterlage behalten wir uns alle Rechte vor.

Kennz. Comp. No.	Benennung Designation	Sachnummer Stock No.	Hersteller Manufacturer	Bezeichnung Designation	enthalten in contained in	
R8	RL 0,60W 12,1KOHM+-1%TK50 RESISTOR	RL 0083.1351.00	RESISTA	MK2	0801.1120.01	
R9	RL 0,60W 4,75KOHM+-1%TK50 RESISTOR	RL 0083.1097.00	RESISTA	MK2	0801.1120.01	
R10	RL 0,60W 10,0KOHM+-1%TK50 RESISTOR	RL 0083.1297.00	RESISTA	MK2	0801.1120.01	
R11	RL 0,60W 24,3KOHM+-1%TK50 RESISTOR	RL 0083.1574.00	RESISTA	MK2	0801.1120.01	
R11	NUR VAR/ONLY MOD: 02 RL 0,60W 66,5KOHM+-1%TK50 RESISTOR	RL 0083.1874.00	RESISTA	MK2	0801.1120.01	
R12	NUR VAR/ONLY MOD: 04 RL 0,60W 4,75KOHM+-1%TK50 RESISTOR	RL 0083.1097.00	RESISTA	MK2	0801.1120.01	
R13	RL 0,60W 11,5KOHM+-1%TK50 RESISTOR	RL 0083.1339.00	RESISTA	MK2	0801.1120.01	
R14	RL 0,60W 100KOHM+-1%TK50 RESISTOR	RL 0082.1764.00	RESISTA	MK2	0801.1120.01	
R16	RL 0,60W 6,81KOHM+-1%TK50 RESISTOR	RL 0082.2560.00	RESISTA	MK2	0801.1120.01	
R16	NUR VAR/ONLY MOD: 02 RL 0,60W 20,0KOHM+-1%TK50 RESISTOR	RL 0083.1522.00	RESISTA	MK2	0801.1120.01	
R17	NUR VAR/ONLY MOD: 04 RL 0,60W 24,3KOHM+-1%TK50 RESISTOR	RL 0083.1574.00	RESISTA	MK2	0801.1120.01	
R17	NUR VAR/ONLY MOD: 02 RL 0,60W 66,5KOHM+-1%TK50 RESISTOR	RL 0083.1874.00	RESISTA	MK2	0801.1120.01	
R18	NUR VAR/ONLY MOD: 04 RL 0,60W 11,5KOHM+-1%TK50 RESISTOR	RL 0083.1339.00	RESISTA	MK2	0801.1120.01	
R19	RL 0,60W 100KOHM+-1%TK50 RESISTOR	RL 0082.1764.00	RESISTA	MK2	0801.1120.01	
R20	RL 0,60W 681 KOHM+-1%TK50 RESISTOR	RL 0083.2735.00	RESISTA	MK2	0801.1120.01	
R21	RL 0,60W 332 KOHM+-1%TK50 RESISTOR	RL 0083.2441.00	RESISTA	MK2	0801.1120.01	
R22	RL 0,40W 10,0KOHM+-1%TK50 RESISTOR	RL 0092.1567.00	RESISTA	MK1 10KO 1% TK50	0801.1120.01	
R25	RL 0,40W 10,0KOHM+-1%TK50 RESISTOR	RL 0092.1567.00	RESISTA	MK1 10KO 1% TK50	0801.1120.01	
R26	RL 0,60W 1KOHM+-1%TK50 RESISTOR	RL 0082.2160.00	RESISTA	MK2	0801.1120.01	
R26	NUR VAR/ONLY MOD: 02 RL 0-OHM-WIDERST. 0204 0-OHM RESISTOR	RL 0069.0000.00	DRALORIC	OMA 0204	0801.1120.01	
R30	NUR VAR/ONLY MOD: 04 RS 0,5W10KOHM+-10%10X10X5 CERMET POTENTIOMETER T	RS 0247.7903.00	SPECTROL	63 M ... TO 10	0801.1120.01	
R30	NUR VAR/ONLY MOD: 02 RS 0,5W1KOHM+-10%10X10X5 CERMET POTENTIOMETER T	RS 0087.7560.00	BOURNS	3386F-1-102	0801.1120.01	
R31	NUR VAR/ONLY MOD: 04 RL 0,60W 332 OHM+-1%TK50 RESISTOR	RL 0083.0255.00	RESISTA	MK2	0801.1120.01	
R32	RL 0,60W 332 OHM+-1%TK50 RESISTOR	RL 0083.0255.00	RESISTA	MK2	0801.1120.01	
R33	RL 0,60W 82,5KOHM+-1%TK50 RESISTOR	RL 0082.2302.00	RESISTA	MK2	0801.1120.01	
R34	RL 0,60W 82,5KOHM+-1%TK50 RESISTOR	RL 0082.2302.00	RESISTA	MK2	0801.1120.01	
R35	RL 0,40W 20,0KOHM+-1%TK50 RESISTOR	0092.0402.00	RESISTA	MK1	0801.1120.01	
R36	RL 0,60W 22,1KOHM+-1%TK50 RESISTOR	RL 0083.1545.00	RESISTA	MK2	0801.1120.01	
V6	AD 1N4448 75V UDI DIODE	AD 0012.0700.00	PHILIPS_SE	1N4448 "	0801.1120.01	
V7	AK BCY79IX P 45V 200MA TRANSISTOR	AK 0010.3777.00	VALVO	BCY79IX	0801.1120.01	
V8	AK BC173C N 25V 100MA TRANSISTOR	0010.4444.00	ITT-SEMICO	BC549C	0801.1120.01	
V10	AD 1N4448 75V UDI DIODE	AD 0012.0700.00	PHILIPS_SE	1N4448 "	0801.1120.01	
V12	AD 1N4448 75V UDI DIODE	AD 0012.0700.00	PHILIPS_SE	1N4448 "	0801.1120.01	
MENP5	413 3PUA	Ät Datum Date	Schaltteilliste für Parts list for		Sachnummer Stock No.	Blatt-Nr. Page
		13 16.09.97	ZE EICHLITUNG (SMG/SMH)		0801.1108.01 SA	2+

Für diese Unterlage behalten
wir uns alle Rechte vor.

Kennz. Comp. No.	Benennung Designation	Sachnummer Stock No.	Hersteller Manufacturer	Bezeichnung Designation	enthalten in contained in
V20	AE BZX55/B8V2 0,5W ZDI ZENER DIODE	AE 0012.2178.00	VALVO	BZX79B8V2	0801.1120.01
V21	AD 1N4448 75V UDI DIODE	AD 0012.0700.00	PHILIPS_SE	1N4448 "	0801.1120.01
V22	AD 1N4448 75V UDI DIODE	AD 0012.0700.00	PHILIPS_SE	1N4448 "	0801.1120.01
V23	AE BZX85/C8V2 1,3W ZDI ZENER DIODE	AE 0092.8526.00	THOMSON	BZX85C8V2	0801.1120.01
V24	AE BAV45 35V PICOAMPDI LOW LEAKAGE DIODE	AE 0252.5386.00	VALVO	BAV45	0801.1120.01
V25	AE BZX55/B8V2 0,5W ZDI ZENER DIODE	AE 0012.2178.00	VALVO	BZX79B8V2	0801.1120.01
V26	AE BZX85/C8V2 1,3W ZDI ZENER DIODE	AE 0092.8526.00	THOMSON	BZX85C8V2	0801.1120.01
V27	AD 1N4448 75V UDI DIODE	AD 0012.0700.00	PHILIPS_SE	1N4448 "	0801.1120.01
V28	AD 1N4448 75V UDI DIODE	AD 0012.0700.00	PHILIPS_SE	1N4448 "	0801.1120.01
V30	NUR VAR/ONLY MOD: 02 AD 1N4448 75V UDI DIODE	AD 0012.0700.00	PHILIPS_SE	1N4448 "	0801.1120.01
V31	NUR VAR/ONLY MOD: 04 AD 1N4448 75V UDI DIODE	AD 0012.0700.00	PHILIPS_SE	1N4448 "	0801.1120.01
V32	AD 1N4448 75V UDI DIODE	AD 0012.0700.00	PHILIPS_SE	1N4448 "	0801.1120.01
V33	AK BC337-40 N 45V 800MA TRANSISTOR	0303.9524.00	ITT	BC337-40	0801.1120.01
V34	AK BC327-40 P 45V 800MA TRANSISTOR	0303.9518.00	PHILIPS_SE	BC327-40	0801.1120.01
W12	DX KABEL W12 CABLE W12	0801.7629.00			
X1	FJ EINBAUBUCHSE SYST.SMA SOCKET	FJ 0294.8154.00	SUHNER	22SMA-50-0-26/111NH	0294.8725.00
X2	FJ EINBAUBUCHSE SYST.SMA SOCKET	FJ 0294.8154.00	SUHNER	22SMA-50-0-26/111NH	0294.8725.00
X41	FP STIFTL.WIN 36P.R2,54 ANGLE PIN CONNECTOR 3-POLIG/3 PINS	FP 0243.3578.00	BINDER	742-5-11-0187-00-36	0801.1120.01
X77A	FP STIFTL.EISTE 36P.R2,54 PIN CONNECTOR 8-POLIG/8 PINS	FP 0242.3600.00	BINDER	742-11-0179-00-36	0801.1120.01
X77B	FP STIFTL.EISTE 36P.R2,54 PIN CONNECTOR 8-POLIG/8 PINS	FP 0242.3600.00	BINDER	742-11-0179-00-36	0801.1120.01
Z1	DT DAEMPFUNGSGLIED40DB/50 ATTENUATOR 40DB/50	0912.5269.00			0294.8725.00
Z2	DT DAEMPFUNGSGLIED20DB/50 ATTENUATOR 20DB/50	0912.5252.00			0294.8725.00
Z3	DT DAEMPFUNGSGLIED 5DB/50 ATTENUATION 5DB/50	0912.5281.00			0294.8725.00
Z4	DT DAEMPFUNGSGLIED20DB/50 ATTENUATOR 20DB/50	0912.5252.00			0294.8725.00
Z5	DT DAEMPFUNGSGLIED10DB/50 ATTENUATOR 10DB/50	0912.5246.00			0294.8725.00
Z6	DT DAEMPFUNGSGLIED40DB/50 ATTENUATOR 40DB/50	0912.5269.00			0294.8725.00
Z7	DT ANSCHLUSSLEITUNG/50 CONNECTION LINE	0915.0800.00			0294.8725.00
Z8	BD UEBERSPANNUNGSSCHUTZ. OVERVOLTAGE PROTECTION	0800.9570.00			0294.8725.00
Z9	LD PI-FILTER FILTER	1008.5850.00			0294.8725.00
Z10	LD PI-FILTER FILTER	1008.5850.00			0294.8725.00

MENP5

413 3PUA

Äl

Datum
Date

Schaltteilliste für
Parts list for

Sachnummer
Stock No.

Blatt-Nr.
Page



ROHDE & SCHWARZ

13

16.09.97

ZE EICHLITUNG (SMG/SMH)

0801.1108.01 SA

3-

Ansicht und Leitungsfuehrung Loetseite
View of tracks on solder side

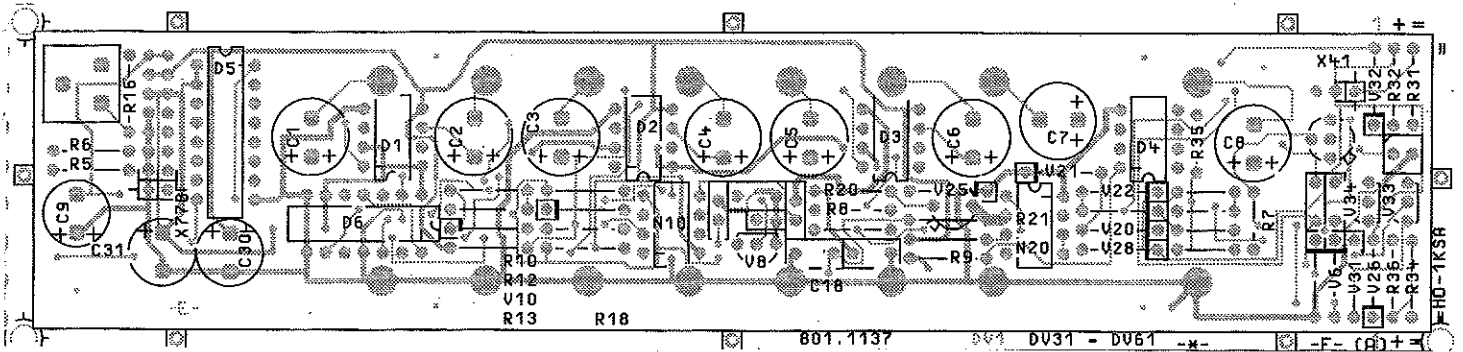

Bindende Angaben über Varianten,
Trimmwerte, Bauteilwerte und
nicht bestückte Bauteile siehe SA

For binding Information on models,
trimming and components values and
nonfitted components see parts list.

K 14	41828	5.89 03.97	HO EI	Maße ohne Toleranzangabe	Maßstab 1 : 1	
					Halbzeug, Werkstoff	
				MENP Bearb. 05.89 Gepr. 03.97 Norm	Tag Name HO EI	Benennung ED Ansteuerung Eichleitung
						Z
				 ROHDE & SCHWARZ	Zeichn.-Nr. 801.1120.01	Blatt-Nr. 2-
Änd. Zust.	Änderungs- Mitteilung	Tag	Name	zu Gerät SMG	reg. i. V. 801.0001 V	erste Z. D
						v. Bl.

Ansicht und Leitungsfuehrung Loetseite
View of tracks on solder side

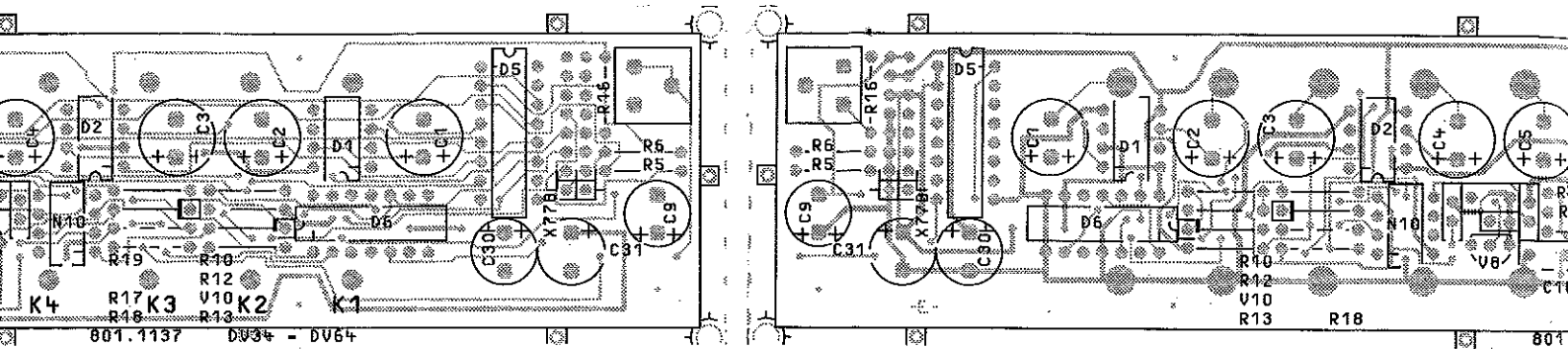

ACHTUNG: EGB!
Elektrostatisch gefaehrdete
Bauelemente erfordern eine
besondere Handhabung.
ATTENTION ESD!
Electrostatic sensitive
devices require a special
handling.

K	41828	5.89	H0	Maße ohne Toleranzangabe		
14	_____	03.97	EI			
				MENP	Tag	Name
				Bearb.	05.89	H0
				Gepr.	03.97	EI
				Norm		
Änd. Zust.	Änderungs-Mitteilung	Tag	Name			

ht und Leitungsfuehrung Bauteilseite
of tracks on component side

Ansicht und
View of tra

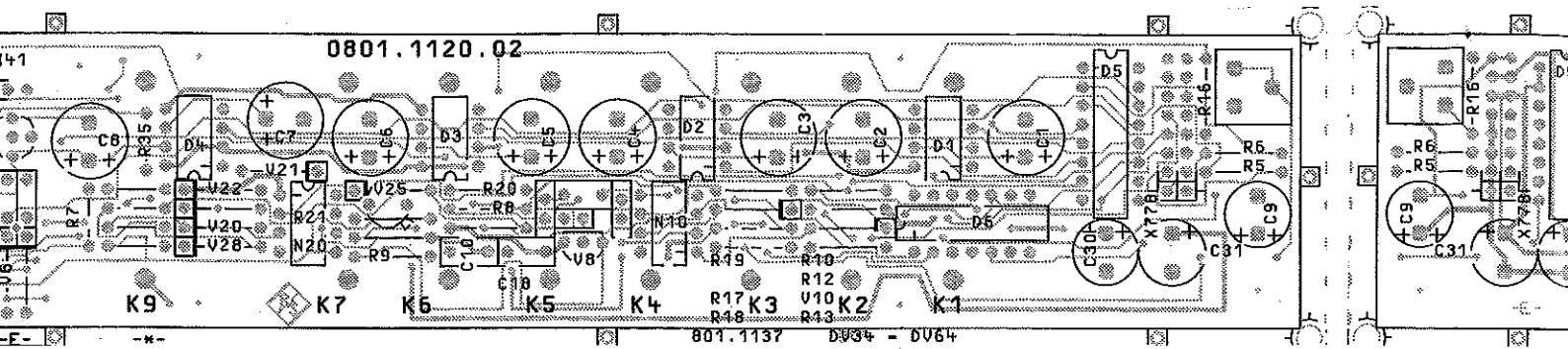

(hierzu HVC 250)



ACHTUNG: EGB!
Elektrostatisch gefährdete
Bauelemente erfordern eine
besondere Handhabung.
ATTENTION ESD!
Electrostatic sensitive
devices require a special
handling.

K	41828
14	
Änd. Zust.	Änder Mittel

A

B

C

D

E

F

Ansicht und Leitungsfuehrung Bauteilseite
View of tracks on component side

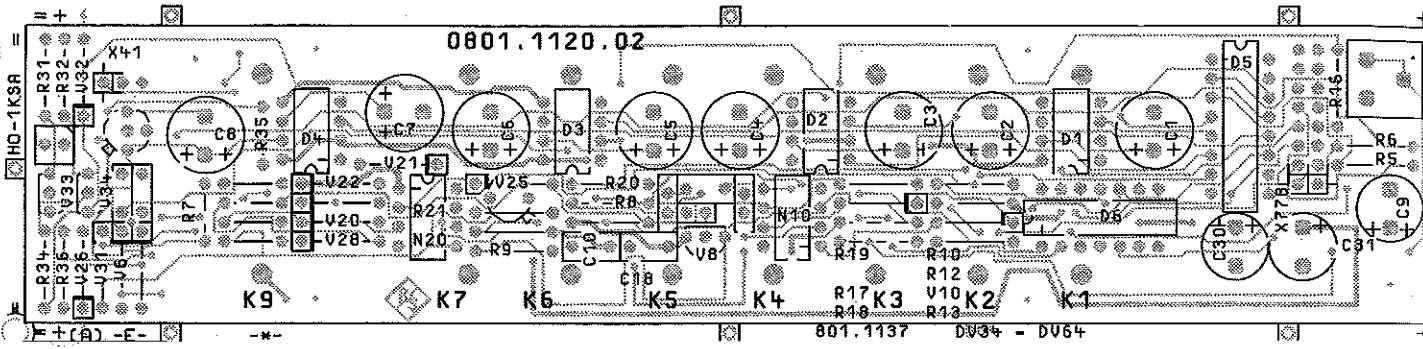

Für diese Unterlage behalten
wir uns alle Rechte vor.

D-Produktion
Methode

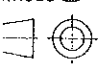

(hierzu HVC 250)



ACHTUNG: EGB!
Elektrostatisch gefährdete
Bauelemente erfordern eine
besondere Handhabung.
ATTENTION ESD!
Electrostatic sensitive
devices require a special
handling.

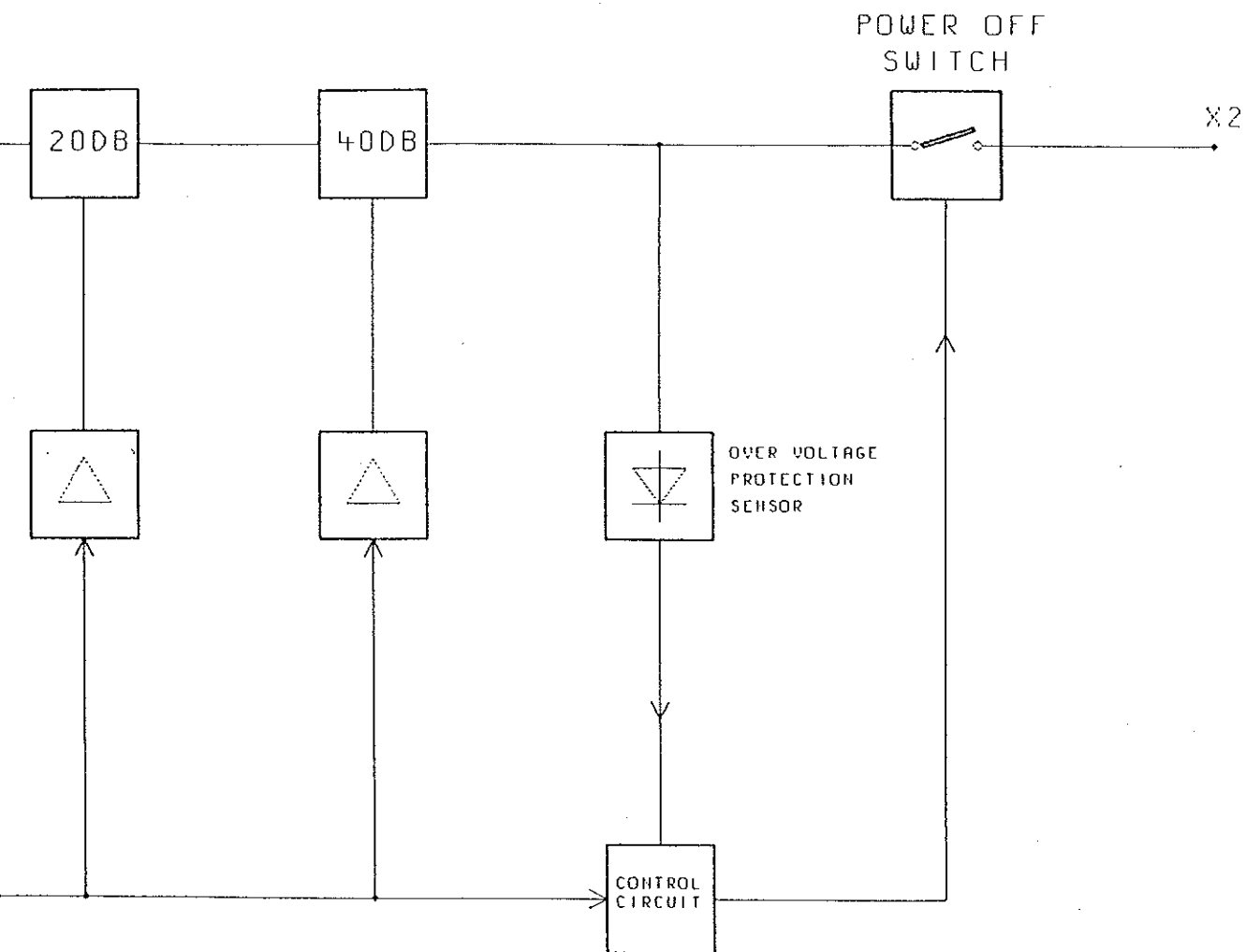

Bindende Angaben über Varianten, Trimmwerte, Bauteilwerte und nicht bestückte Bauteile siehe SA

For binding information on models, trimming and components values and nonfitted components see parts list.

OS/	46470	11.04.95	HM	MENP	TAG	NARE	BENENNUNG	
06		03.97	BI	BERPB.	03.97	EI	ZE EICHLLEITUNG	
				GEPP.			ATTENUATORS	
				NORN				
				PLOTT				
/						ZEICHN.-NR.		BLATT-NR.
REND. IND.	RENDPUNGS-NITTEILUNG	DATA	NARE			ROHDE & SCHWARZ		801.1108.01S
				ZU GERACHT	SMG	RES. I V	801.0001	ERSTE Z

ATTENUATORS

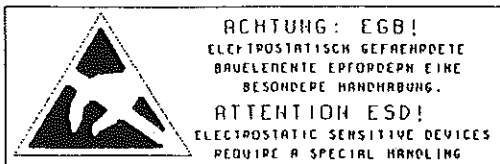
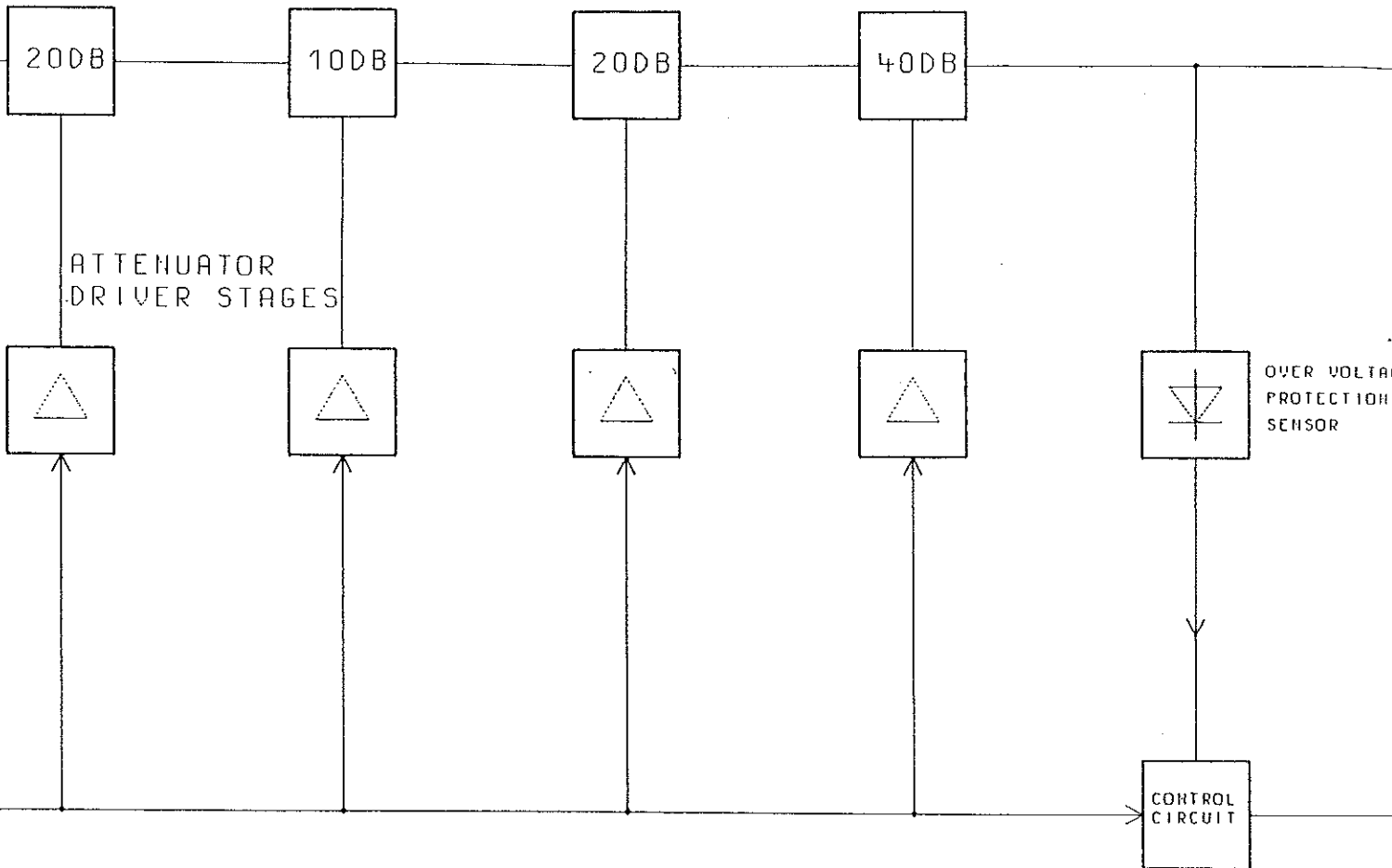

05/	46470	11.04.95	HM	MENP	TAG	NAME	BENENNUNG
06		03.97	BI	BERAB.	03.97	EI	ZE EI ATT
				GEPP.			
				NOPN			
				PLOTT			
/							ZEICHN.-N.
REND. IND.	RECHENUNGS- MITTEILUNG	DATUM	NAME	 ROHDE & SCHWARZ		ZU GERÄT SMG PEG. 1 V	

ATTENUATORS

X1

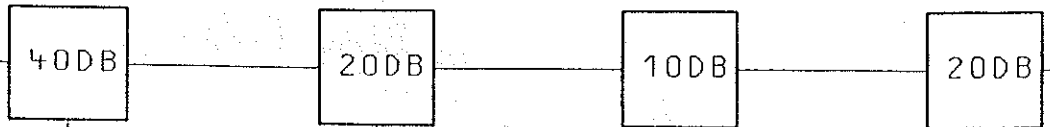

ATTENUATOR
DRIVER STAGES



DATA
BUS

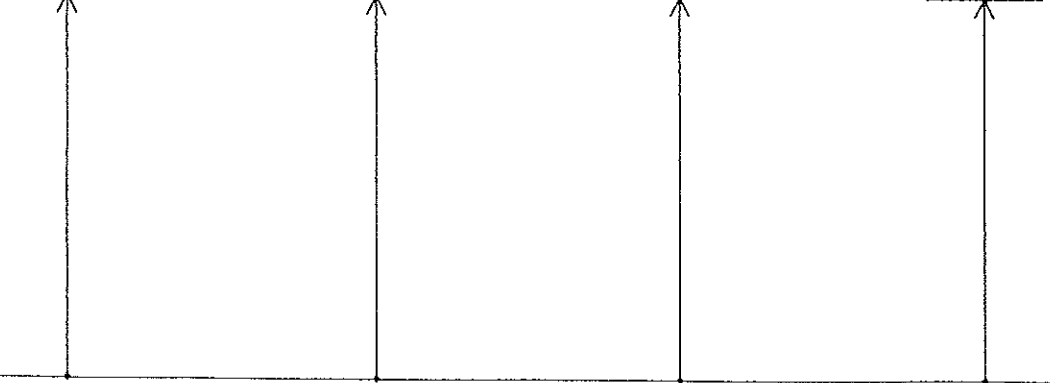



ACHTUNG: EGB!
 ELEKTROSTATISCH GEFÄHRDETE
 BAUELEMENTE ERFORDERN EINE
 BESONDERE HANDHABUNG.
ATTENTION ESD!
 ELECTROSTATIC SENSITIVE DEVICES
 REQUIRE A SPECIAL HANDLING.

DS/	46470
06	
/	
RENO.	RENDERUNGS-
IND.	MITTEILUNG

ATTENUATORS

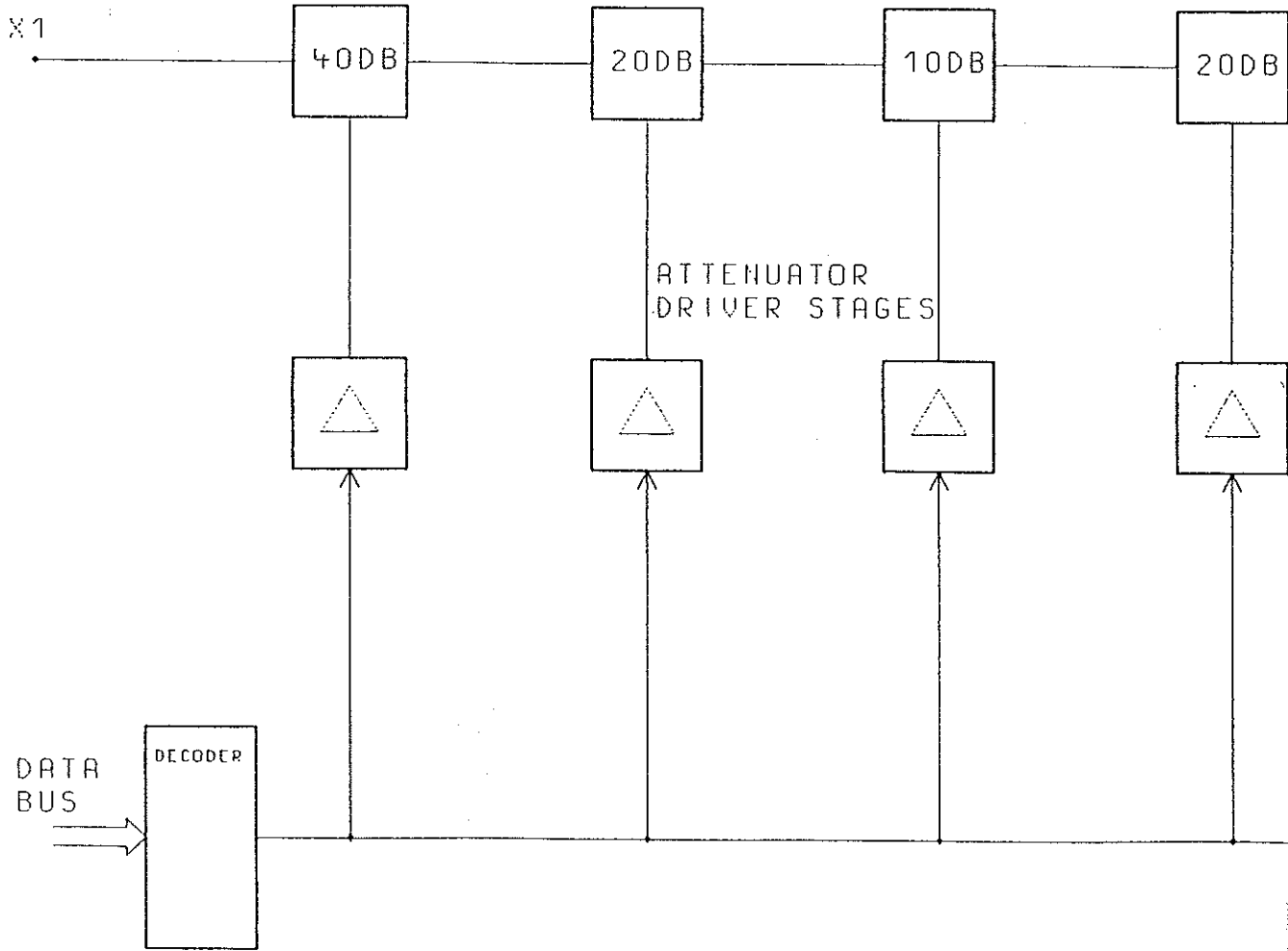

ACHTUNG: EGB!
 ELEKTROSTATISCH GEFÄHRDETE
 BAUELEMENTE ERFORDERN EINE
 BESONDERE HANDHABUNG.
ATTENTION ESD!
 ELECTROSTATIC SENSITIVE DEVICES
 REQUIRE A SPECIAL HANDLING

05/	46470
06	
RENO IND.	RENDPUNGS- MITTEILUNG

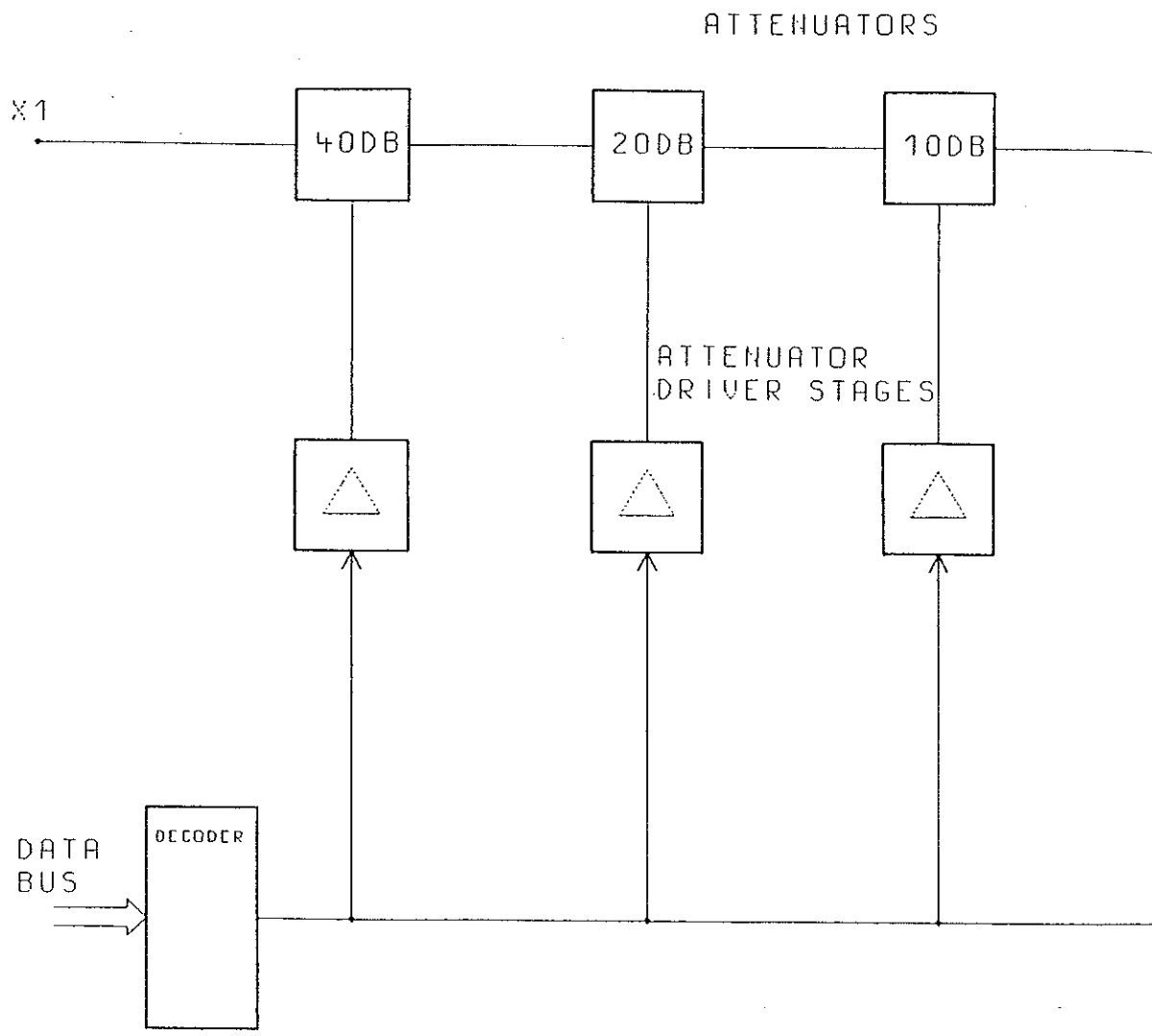

SEHLEN SIE UNS ALLE FEHLENDEN SEITEN MIT.

F
E
D
C
B
1 2 3 4 5

ACHTUNG: EGB!
 ELEKTROSTATISCH GEFÄHRDETE
 BAUELEMENTE ERFORDERN EINE
 BESONDERE HANDHABUNG.
ATTENTION ESD!
 ELECTROSTATIC SENSITIVE DEVICES
 REQUIRE A SPECIAL HANDLING

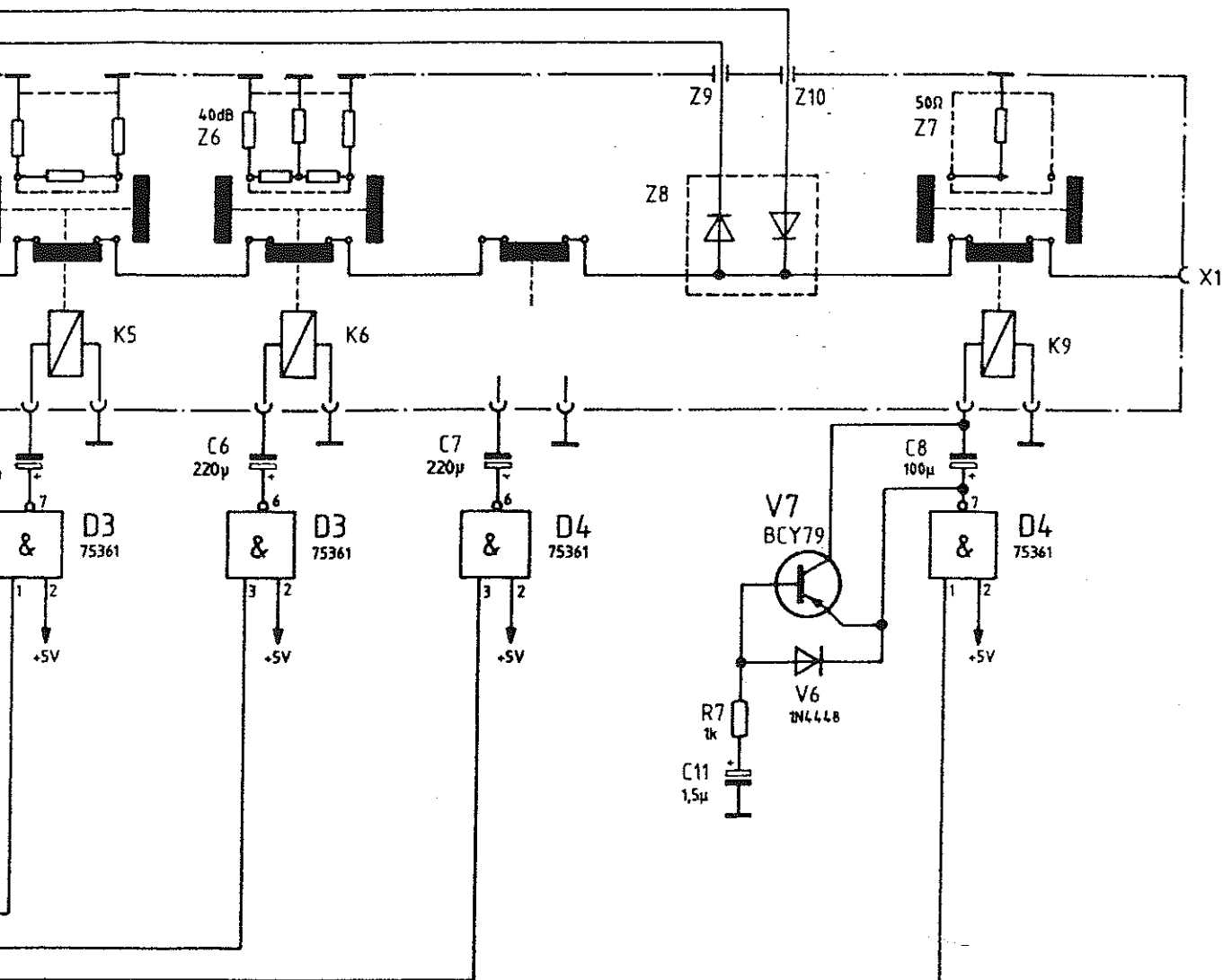

* = VAR./MOD. D4



ACHTUNG EGB!
Elektrostatisch gefährdete Bauelemente erfordern eine besondere Handhabung
ATTENTION ESD!
Electrostatic sensitive devices require a special handling

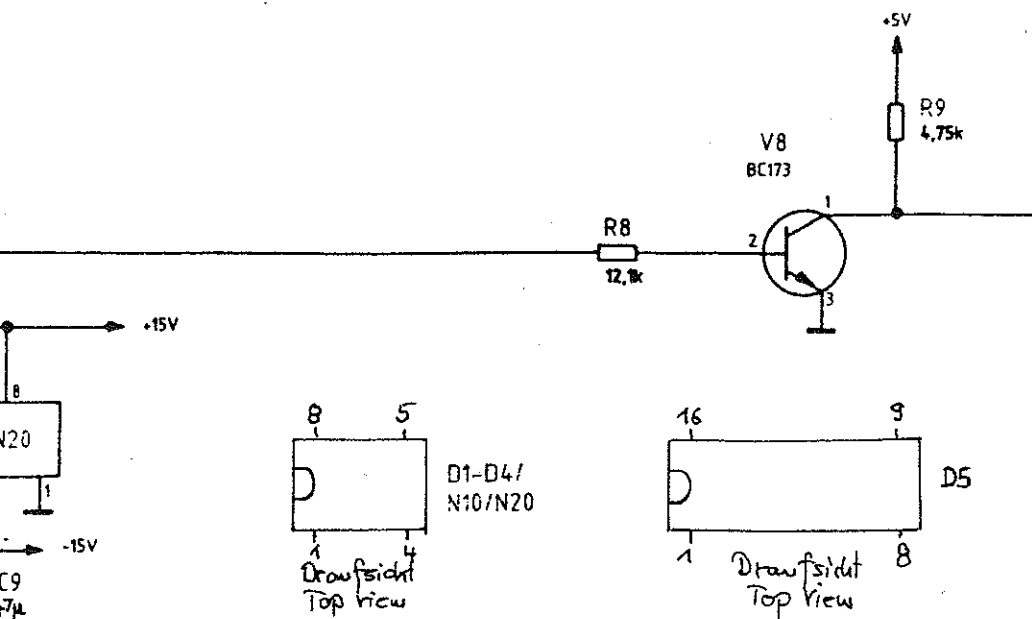

Bottom view



E B C
V8/V33/
V34

NAME CO EI	Bezeichnung: ZE Eichleitung Attenuator	Z	Zeichnung: 801.1108.01 s	Blatt-Nr.: 3-
	zu Best: SMG		801.0901 V	801.0001

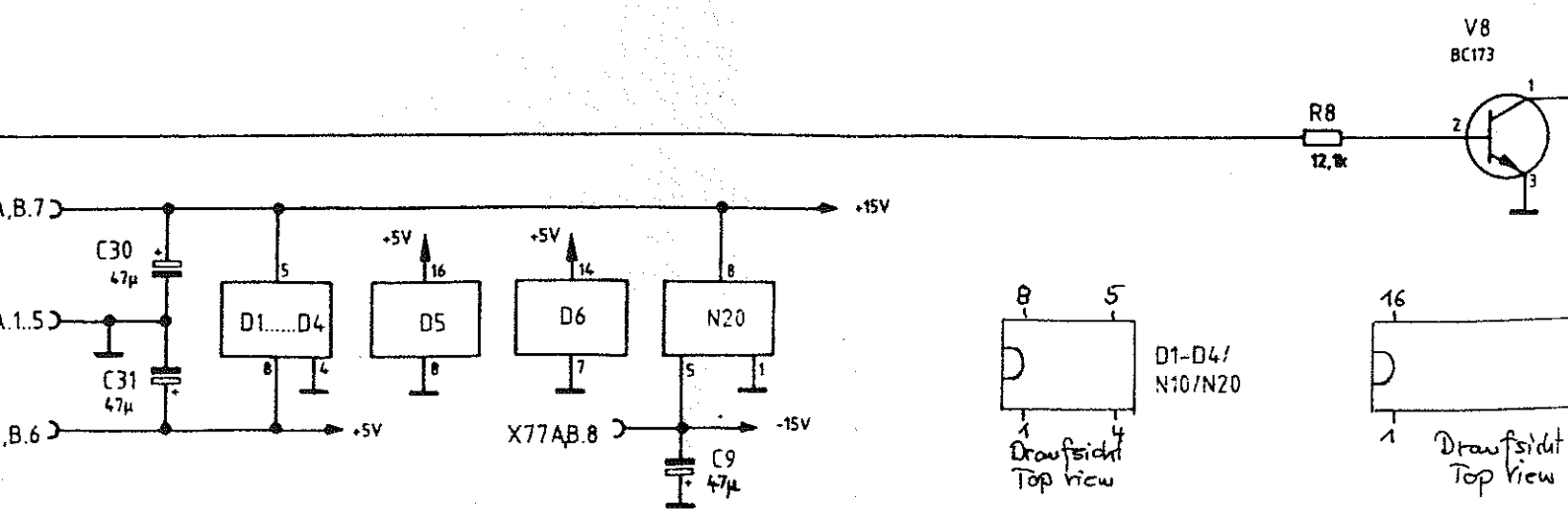
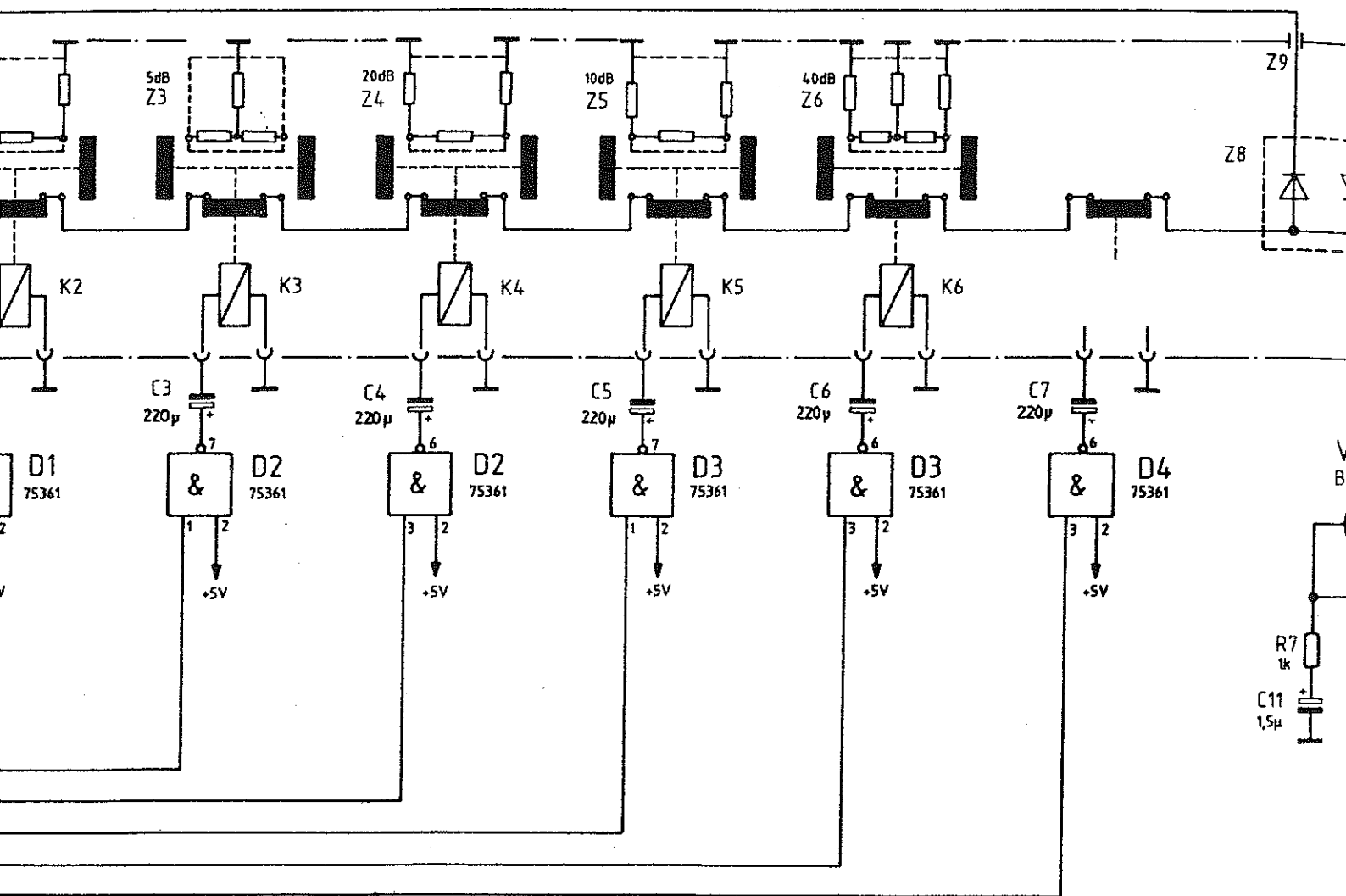

HO	04		03.92	HM	MENP	Top	Name	Generierung	ZE Eicheitung		
HO	05	46470	04.95	HT	Bearb	10.85	CO		Attenuator	Z	
LS	06		03.97	ET	Gepr	03.97	EI				
Name			Datum	Name	Norm				zu Gepr	SMG	

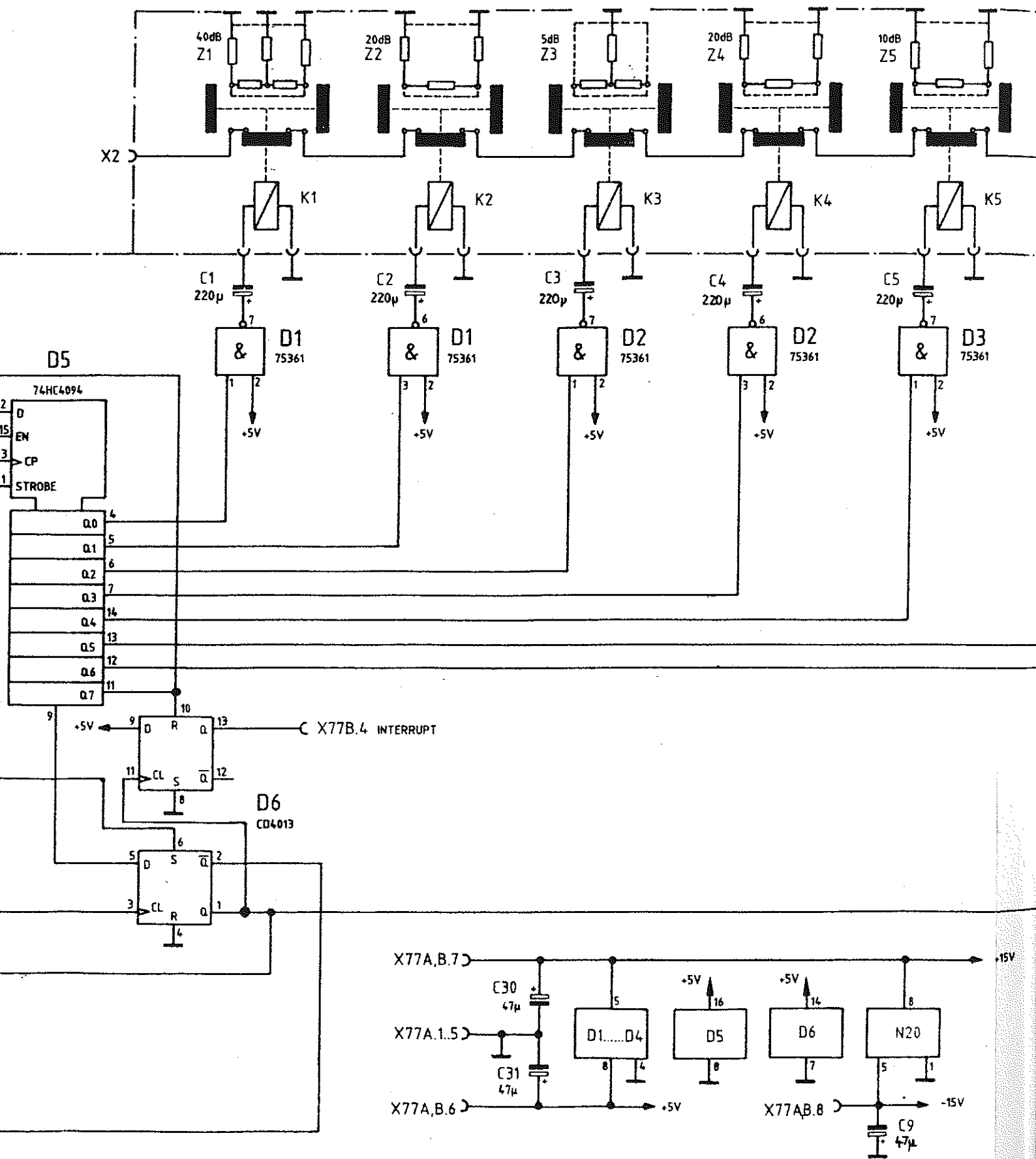

A	41828	06.89	HO	04		03.92	HM	MENP	Tap	Name	Bezeichnung
B	41828	8.89	HO	05	46470	04.95	HM	Beord	10.85	CO	
C	41828	12.89	LS	06		03.97	ET	Gear	03.97	EI	
D		Datum	Name	Art	Art	Datum	Name	Norm			

90 801.1120.02/04 = *
 nsteuerung/Eichleitung
 ttenuator Control

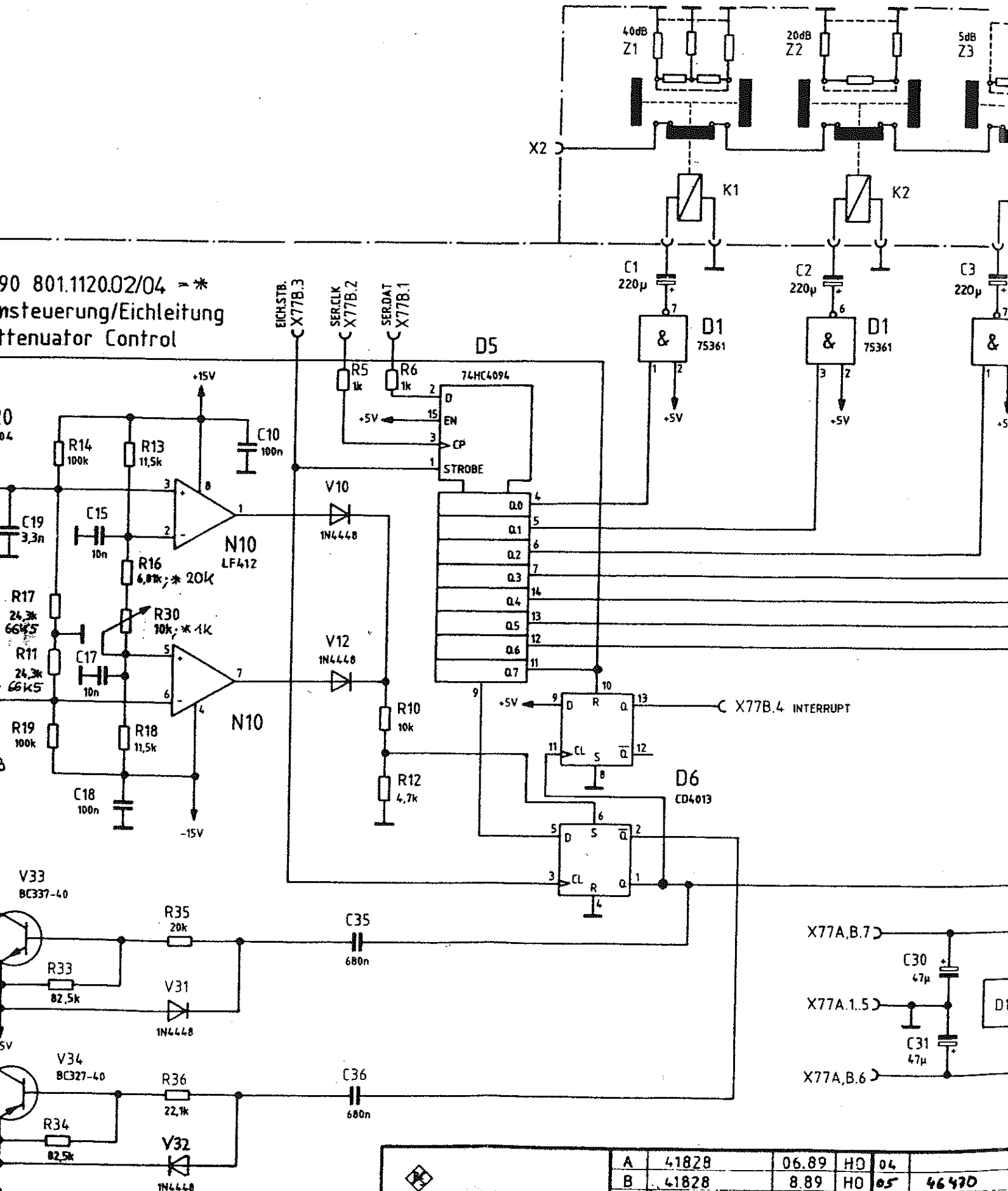

	A	41828	06.89	HO	04	
	B	41828	8.89	HO	05	46470
	03	41828	12.89	LS	06	
	52			Datum	Name	

W12

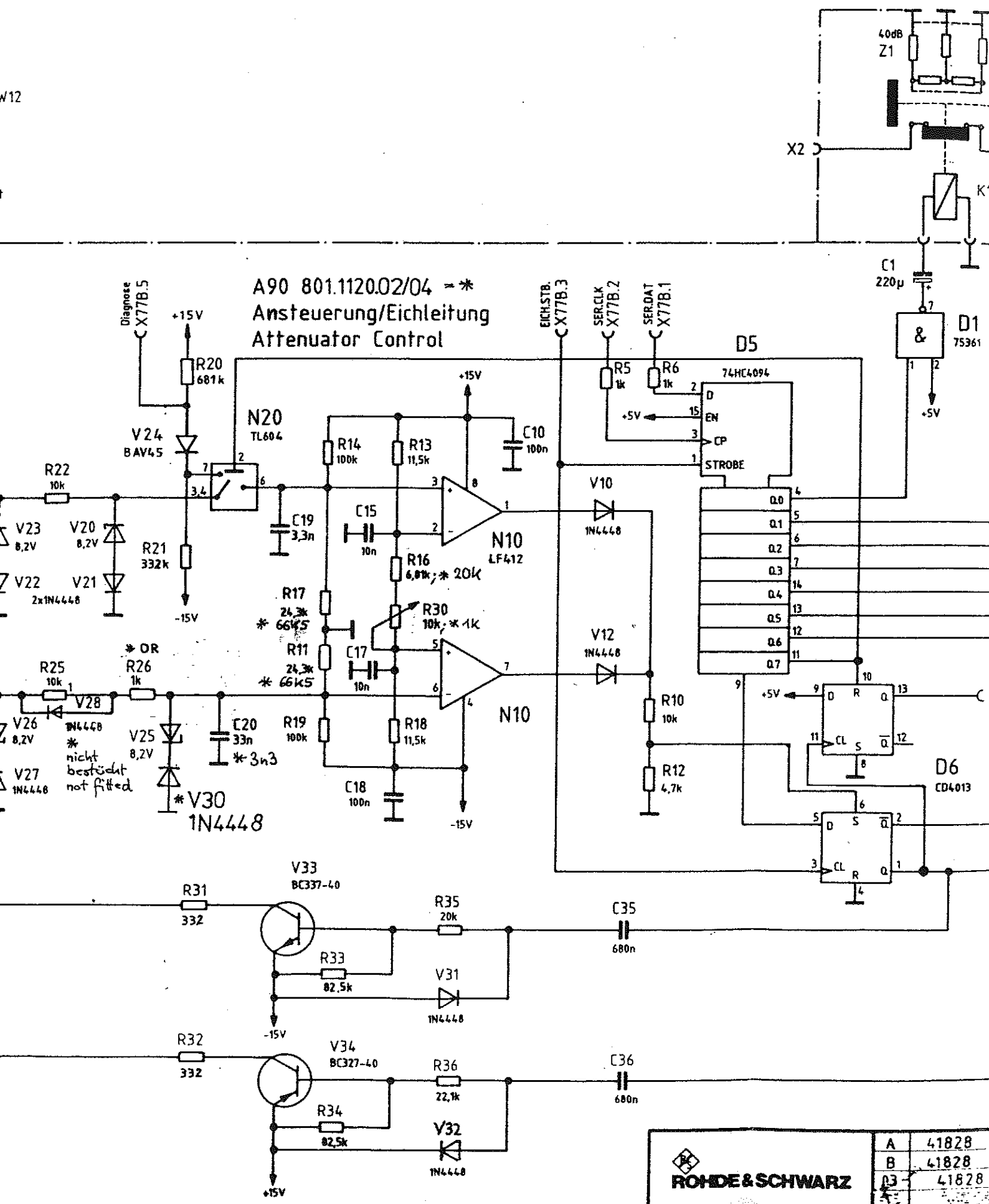

A90 801.1120.02/04 = *
 Ansteuerung/Eichleitung
 Attenuator Control

V23 8,2V
 V20 8,2V
 V22 2x1N4448
 V21
 V26 8,2V
 V27 1N4448
 V28
 V25 8,2V
 V30 1N4448
 * nicht bestückt
 not fitted

R17 24,3k
 * 66k5
 R11 24,3k
 * 66k5

Für diese Unterlage behalten wir uns alle Rechte vor

Zeichn.-Nr. 801.1114 S

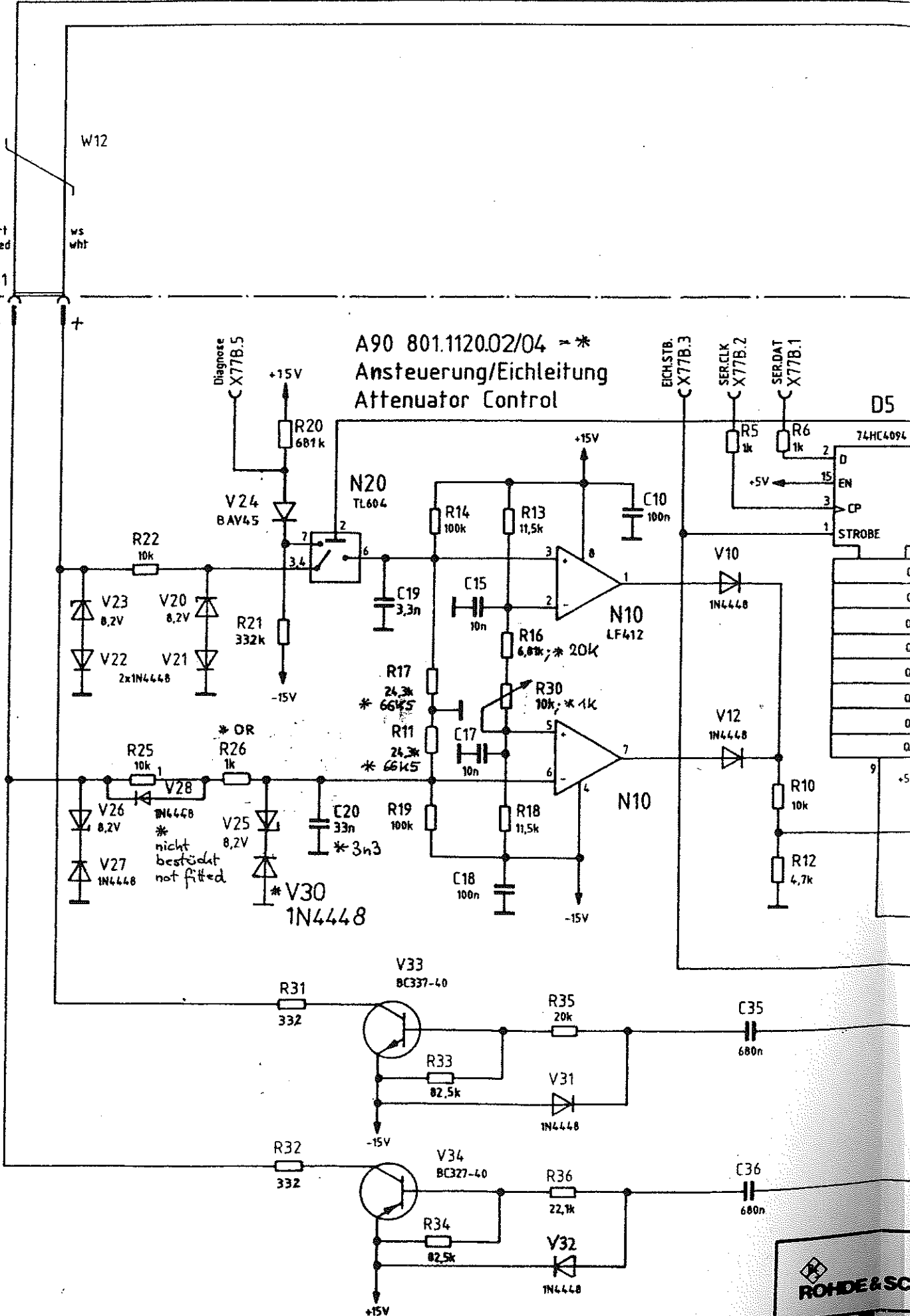



ROHDE&SCHWARZ

SERVICEUNTERLAGEN

NETZTEIL

1062.5690.02

Inhaltsverzeichnis

7 Prüfen und Instandsetzen der Baugruppe.....	5
7.1 Funktionsbeschreibung.....	5
7.2 Meßgeräte und Hilfsmittel.....	5
7.3 Fehlersuche.....	5
7.4 Allgemeine Daten.....	5
7.4.1 Oberspannung unbelastet.....	6
7.4.2 Oberspannung belastet.....	6
7.4.3 Brummspannung.....	6
7.5 Prüfen und Abgleich.....	6
7.5.1 Prüfen des Regelverhaltens und der Störspannung.....	6
7.5.2 Kurzschlußverhalten.....	7
7.6 Zerlegung und Zusammenbau.....	7
7.7 Externe Schnittstelle.....	7

Schaltteilliste
Koordinatenliste
Stromlauf
Bestückungsplan

7.1 Funktionsbeschreibung

Das Netzteil versorgt die Baugruppen des Gerätes mit fünf geregelten Gleichspannungen von -15V, +24V, +15V, +7.5V sowie +5.1V. Zusätzlich wird der Lüfter des Gerätes aus der Oberspannung des +7.5V Regelteils versorgt.

Der Netztrafo wird primärseitig über ein Netzfilter und einen Spannungswähler gespeist.

Es stehen vier Primärspannungen zur Auswahl: 100V, 120V, 220V und 230V.

Der Netztrafo ist primärseitig durch eine Schmelzsicherung gegen Kurzschluß sowie über eine in die Trafоеinheit vergossene Thermosicherung gegen thermische Überlastung geschützt.

Auf der Sekundärseite weist der Netztrafo vier Wicklungen auf, die die Brückengleichrichterschaltungen speisen.

Die an den vier Ladekondensatoren der Gleichrichterschaltungen anstehenden Oberspannungen werden vier integrierten Spannungsreglerschaltungen zugeführt. Der +5.1V Spannungsregler wird von der Ausgangsspannung des +7.5V Reglers gespeist.

Die Ausgangsspannungen der Spannungsregler sind entweder intern oder durch äußere Beschaltung festgelegt.

7.2 Meßgeräte und Hilfsmittel

- Digitalmultimeter (z.B. R&S UDS5)
- Stelltrafo 90V...265V, 50Hz
- Oszilloskop
- Elektronische Last

7.3 Fehlersuche**Ausfall aller Spannungen**

Spannungswähler auf korrekte Einstellung, Netzsicherung und ggf. Thermoschalter überprüfen.

Ausfall einer Spannung

Das Netzteil entlasten und entsprechenden Reglerbaustein überprüfen (ggf. ist auch die Last zu überprüfen).

7.4 Allgemeine Daten

Die angeführten Werte der Oberspannungen und Brummspannungen der Gleichrichterschaltungen sollen als zusätzliche Angaben die Fehlersuche erleichtern. Sie sind nicht Bestandteil der Baugruppenprüfung. Die Werte gelten bei einer Netzspannung von 230V \pm 1V und 50Hz Netzfrequenz.

7.4.1 Oberspannung unbelastet

Spannungen an Ladeelko gemessen				
+5.1V	+7.5V	+15.0V	+24.0V	-15.0V
+7.5 ±0.3V	+13.2V ±1.0V	+24.8V ±1.0V	+38.8V ±1.0V	-24.9V ±1.0V

7.4.2 Oberspannung belastet

Spannungen an Ladeelko gemessen				
+5.1V (1.0A)	+7.5V (0.95A)	+15.0V (1.5A)	+24.0V (0.3A)	-15.0V (0.5A)
+7.5 ±0.3V	+10.9V ±1.0V	+20.7V ±1.0V	+32.2V ±1.0V	-21.3V ±1.0V

7.4.3 Brummspannung

Spannungen an Ladeelko gemessen			
+7.5V	+15.0V	+24.0V	-15.0V
max. 500mVss	max. 400mVss	max. 50mVss	max. 300mVss

7.5 Prüfen und Abgleich

Alle Meßwerte ohne Toleranzangaben sind als Richtwerte zu verstehen. Spannungen ohne weitere Bezeichnungen bedeuten DC-Spannungen.

7.5.1 Prüfen des Regelverhaltens und der Störspannung

- Spannungswähler auf 230V einstellen

– Die Netzspannung von 230V auf 207V ändern und max. Änderung und Störspannung nach der Tabelle überprüfen.

Meßpunkt	Bezugspunkt	Spannung	Toleranz	Max. Änderung	Störsp. Ueff
X22.1	GND	+5.1V	±4%	20mV	<3mV
X22.4	GND	+7.5V	±4%	50mV	<3mV
X22.2	GND	+15.0V	±4%	50mV	<3mV
X22.22	GND	+24.0V	±4%	70mV	<3mV
X22.6	GND	-15.0V	±4%	50mV	<3mV

7.5.2 Kurzschlußverhalten

- Netzteil unbelastet (Kabel zum Motherboard und Option ROSC abziehen)
- Upr. = 230V ±1V
- Frequenz 50Hz

- _ Ausgangsspannungen nacheinander kurzschließen und Kurzschlußstrom bestimmen.
- _ Funktion der Regler durch Messung der Ausgangsspannungen (siehe 7.4.1) prüfen.

Ua (V)	Pin (X3)	Bezug	Kurzschlußstrom
+5.1V	X21.5\6\7	GND	<4.5A
+7.5V	X21.8	GND	<4.5A
+15.0V	X21.13\14\15\16	GND	<4.0A
+24.0V	X21.22	GND	<2.5A
-15.0V	X21.19\20	GND	<2.5A

GND X21.1\2\3
 X21.9\10\11\12
 X21.17\18
 X21.21

7.6 Zerlegung und Zusammenbau

Nach dem Öffnen des Gerätes und der gekennzeichneten Schrauben auf der Rückwanne sowie dem Lösen des Kabels W21, kann die Baugruppe aus dem Rahmen herausgenommen werden. Der Einbau der Baugruppe und Zusammenbau des Gerätes erfolgt entsprechend in umgekehrter Reihenfolge.

7.7 Externe Schnittstelle

Pin	Name	Ein/Ausgang	Herkunft/Ziel	Wertebereich	Signalbeschreibung
X4.1	LÜFTPLU	Ausgang	Lüfter	9V...13V	Plusspannung
X4.2	LÜFTMIN	Ausgang	Lüfter		Masse
X4.3	CODE				
X4.4	TEMPREG	Ausgang	Lüfter	100kΩ NTC	Temperaturregelung
X21.4	U5VC	Ausgang	A3 MBRD X21.4	+7.2V...+7.8V	+5V Überspannung für Reset
X21.5	VA5-P	Ausgang	A3 MBRD 21.5	+4.9V...+5.3V	+5.1V Versorgungsspannung
X21.6	VA5-P	Ausgang	A3 MBRD X21.6	+4.9V...+5.3V	+5.1V Versorgungsspannung
X21.7	VA5-P	Ausgang	A3 MBRD X21.7	+4.9V...+5.3V	+5.1V Versorgungsspannung
X21.8	VA7.5-P	Ausgang	A3 MBRD X21.8	+7.2V...+7.8V	+7.5V Versorgungsspannung
X21.13	VA15-P	Ausgang	A3 MBRD X21.13	+14.4V...+15.6V	+15V Versorgungsspannung
X21.14	VA15-P	Ausgang	A3 MBRD X21.14	+14.4V...+15.6V	+15V Versorgungsspannung
X21.15	VA15-P	Ausgang	A3 MBRD X21.15	+14.4V...+15.6V	+15V Versorgungsspannung
X21.16	VA15-P	Ausgang	A3 MBRD X21.16	+14.4V...+15.6V	+15V Versorgungsspannung
X21.19	VA15-N	Ausgang	A3 MBRD X21.19	-15.6V...-14.4V	-15V Versorgungsspannung
X21.20	VA15-N	Ausgang	A3 MBRD X21.20	-15.6V...-14.4V	-15V Versorgungsspannung
X21.22	VA24-P	Ausgang	A3 MBRD X21.22	+23.0V...+25.0V	+24V Versorgungsspannung
X21.23	OVENCOLD	Ausgang	A3 MBRD X21.23	HCMOS-Pegel	Ofen kalt (Opt Ref. Oszill.)
X21.24	OPTTUNE	Eingang	A3 MBRD X21.24	0V...10V	Abstimmspannung (Opt Ref Osz)
X21.25	REFOFF	Eingang	A3 MBRD X21.25	HCMOS-Pegel	ON/OFF (Option Ref. Oszill.)

Pin	Name	Ein/Ausgang	Herkunft/Ziel	Wertebereich	Signalbeschreibung
X21.26	OPTERKREF	Ausgang	A3 MBRD X21.26	HCMOS-Pegel	Optionerkennung Ref. Oszillator
X22.1	VA5-P	Ausgang	A8 ROSC X22.1	+4.9V...+5.3V	+5V Versorgungsspannung
X22.2	VA15-N	Ausgang	A8 ROSC X22.2	-15.6V...-14.4V	-15V Versorgungsspannung
X22.3	frei				
X22.4	REFOFF	Ausgang	A8 ROSC X22.4	HCMOS-Pegel	Ref. Oszillator ON/OFF (Option)
X22.5	OPTERKREF	Eingang	A7 POWS X21.26	HCMOS-Pegel	Optionerkennung
X22.6	VA15-N	Ausgang	A8 ROSC X22.6	-15.6V...-14.4V	-15V Versorgungsspannung
X22.7	frei				
X22.9	frei				
X22.11	frei				
X22.12	frei				
X22.13	OVENCOLD	Eingang	A7 POWS X21.23	HCMOS-Pegel	Ofen kalt (Option)
X22.16	OPTTUNE	Ausgang	A8 ROSC X22.16	0V...10V	Abstimmspannung (Option)

GND X21.1\2\3\9\10\11\12\17\18\21
X22.8\10\14\15



ROHDE & SCHWARZ

SERVICE INSTRUCTIONS

Power Supply

1062.5690.02

Contents

7	Testing and Repair of the Module.....	5
7.1	Function Description.....	5
7.2	Test Instruments and Utilities.....	5
7.3	Troubleshooting.....	5
7.4	General Data.....	5
7.4.1	High-end Voltage without Load.....	6
7.4.2	High-end Voltage under Load.....	6
7.4.3	Hum Voltage.....	6
7.5	Testing and Adjustment.....	6
7.5.1	Testing Regulating Performance and Noise Voltage.....	6
7.5.2	Short-Circuit Test.....	7
7.6	Disassembly and Assembly.....	7
7.7	External Interface.....	7

Parts list
List of coordinates
Circuit diagram
Component layout diagram

7.1 Function Description

The power supply provides five regulated dc voltages of -15V, +24V, +15V, +7.5V and +5.1V. The voltage for the blower is derived from the high-end voltage of the +7.5 regulator.

The power transformer is primary fed via an ac filter and a voltage selector.

Four primary voltages can be selected: 100V, 120V, 220V and 230V.

The power transformer is provided with a fuse to protect it against short-circuits. A thermal release encapsulated in the transformer section protects it against thermal overload.

On the secondary side, the transformer provides four windings which feed the bridge rectifier circuits.

The high-end voltages available at the four charging capacitors of the rectifier circuits are applied to four integrated voltage-regulating circuits. The voltage for the +5.1V voltage regulator is derived from the output voltage of the +7.5V regulator.

The output voltages of the voltage regulators are either fixed internally or by external circuitry.

7.2 Test Instruments and Utilities

- Digital multimeter (e.g., R&S UDS5)
- Variable-ratio transformer 90V to 265V, 50Hz
- Oscilloscope
- Electronic load

7.3 Troubleshooting

Failure of all voltages	Check, whether voltage selector has been set correctly, check fuse and thermal protection, if necessary.
Failure of a single voltage	Disconnect the power supply from the load and check the regulating component of interest (check load, if required).

7.4 General Data

The data of the high-end and hum voltages of the rectifier circuits are given in addition to make troubleshooting easier. They are not tested with the board test. The values given apply for an ac voltage of 230V \pm 1V and an ac supply frequency of 50Hz.

7.4.1 High-end Voltage without Load

Voltages measured at charging capacitor				
+5.1V	+7.5V	+15.0V	+24.0V	-15.0V
+7.5 ±0.3V	+13.2V ±1.0V	+24.8V ±1.0V	+38.8V ±1.0V	-24.9V ±1.0V

7.4.2 High-end Voltage under Load

Voltages measured at charging capacitor				
+5.1V (1.0A)	+7.5V (0.95A)	+15.0V (1.5A)	+24.0V (0.3A)	-15.0V (0.5A)
+7.5 ±0.3V	+10.9V ±1.0V	+20.7V ±1.0V	+32.2V ±1.0V	-21.3V ±1.0V

7.4.3 Hum Voltage

Voltages measured at charging capacitor			
+7.5V	+15.0V	+24.0V	-15.0V
max. 500mVpp	max. 400mVpp	max. 50mVpp	max. 300mVpp

7.5 Testing and Adjustment

All measured values indicated without tolerances are recommended values. Voltages given without any further detail are dc voltages.

7.5.1 Testing Regulating Performance and Noise Voltage

- Set voltage selector to 230 V.

_ Vary the ac supply voltage from 230 V to 207 V and check max. deviation and noise voltage according to the table below.

Test point	Ref. point	Voltage	Tolerance	Max.deviation	Noise voltage V _{rms}
X22.1	GND	+5.1V	±4%	20mV	<3mV
X22.4	GND	+7.5V	±4%	50mV	<3mV
X22.2	GND	+15.0V	±4%	50mV	<3mV
X22.22	GND	+24.0V	±4%	70mV	<3mV
X22.6	GND	-15.0V	±4%	50mV	<3mV

7.5.2 Short-Circuit Test

- Power supply without load (withdraw cables to motherboard and ROSC option)
 - Vpr. = 230V ±1V
 - Frequency 50Hz
- Successively short-circuit output voltages and determine the short-circuit current.
- Check, if the regulators work correctly by measuring the output voltages (cf. 7.4.1).

Va (V)	Pin (X3)	Reference	Short-circuit current
+5.1V	X21.5\6\7	GND	<4.5A
+7.5V	X21.8	GND	<4.5A
+15.0V	X21.13\14\15\16	GND	<4.0A
+24.0V	X21.22	GND	<2.5A
-15.0V	X21.19\20	GND	<2.5A

GND X21.1\2\3
 X21.9\10\11\12
 X21.17\18
 X21.21

7.6 Disassembly and Assembly

Subsequent to opening the instrument, undoing the screws marked on the backpanel and disconnecting the cable W21, the module can be removed from the frame.

Installation of the module and reassembly of the instrument are carried out in the reverse order.

7.7 External Interface

Pin	Name	Input/Output	Origin/Dest.	Specified range	Signal description
X4.1	LÜFTPLU	Output	Blower	9V to 13V	Positive voltage
X4.2	LÜFTMIN	Output	Blower		Ground
X4.3	CODE				
X4.4	TEMPREG	Output	Blower	100kΩ NTC	Temperature control
X21.4	U5VC	Output	A3 MBRD X21.4	+7.2V to +7.8V	+5V Overvoltage for reset
X21.5	VA5-P	Output	A3 MBRD 21.5	+4.9V to +5.3V	+5.1V jSupply Voltage
X21.6	VA5-P	Output	A3 MBRD X21.6	+4.9V to +5.3V	+5.1V Supply Voltage
X21.7	VA5-P	Output	A3 MBRD X21.7	+4.9V to +5.3V	+5.1V Supply Voltage
X21.8	VA7.5-P	Output	A3 MBRD X21.8	+7.2V to +7.8V	+7.5V Supply Voltage
X21.13	VA15-P	Output	A3 MBRD X21.13	+14.4V to +15.6V	+15V Supply Voltage
X21.14	VA15-P	Output	A3 MBRD X21.14	+14.4V to +15.6V	+15V Supply Voltage
X21.15	VA15-P	Output	A3 MBRD X21.15	+14.4V to +15.6V	+15V Supply Voltage
X21.16	VA15-P	Output	A3 MBRD X21.16	+14.4V to +15.6V	+15V Supply Voltage
X21.19	VA15-N	Output	A3 MBRD X21.19	-15.6V to -14.4V	-15V Supply Voltage
X21.20	VA15-N	Output	A3 MBRD X21.20	-15.6V to -14.4V	-15V Supply Voltage
X21.22	VA24-P	Output	A3 MBRD X21.22	+23.0V to +25.0V	+24V Supply Voltage
X21.23	OVENCOLD	Output	A3 MBRD X21.23	HCMOS level	Oven cold (ref osc option)
X21.24	OPTTUNE	Input	A3 MBRD X21.24	0V to 10V	Tuning volt. (ref osc option)
X21.25	REFOFF	Input	A3 MBRD X21.25	HCMOS level	ON/OFF (ref osc option)

Pin	Name	Input/Output	Origin/Dest.	Specified range	Signal description
X21.26	OPTERKREF	Output	A3 MBRD X21.26	HCMOS level	Identification of ref. oscillator option
X22.1	VA5-P	Output	A8 ROSC X22.1	+4.9V to +5.3V	+5V Supply Voltage
X22.2	VA15-N	Output	A8 ROSC X22.2	-15.6V to -14.4V	-15V Supply Voltage
X22.3	not used				
X22.4	REFOFF	Output	A8 ROSC X22.4	HCMOS level	Ref. osc. option ON/OFF
X22.5	OPTERKREF	Input	A7 POWS X21.26	HCMOS level	Identification of option
X22.6	VA15-N	Output	A8 ROSC X22.6	-15.6V to -14.4V	-15V Supply Voltage
X22.7	not used				
X22.9	not used				
X22.11	not used				
X22.12	not used				
X22.13	OVENCOLD	Input	A7 POWS X21.23	HCMOS level	Oven cold (option)
X22.16	OPTTUNE	Output	A8 ROSC X22.16	0V to 10V	Tuning voltage (option)

GND X21.1\2\3\9\10\11\12\17\18\21
X22.8\10\14\15



ROHDE & SCHWARZ

Schaltteillisten
numerisch geordnet

Part lists
in numerical order

Listes des pièces détachées
par numéros de référence

F3	0020.7600.00	SS SCHMELZS.T4 IEC127-2N	1	ST
F4	0009.0584.00	SS SCHMELT3.15IEC127-2I3	1	ST
F5	0009.5434.00	SS SCHMELZS.T1 IEC127-2N	1	ST
F6	1062.5702.00	SS SCHMELZS. 2.5AT	1	ST

Sicherungen im
SMY Netzteil

Für diese Unterlage behalten
wir uns alle Rechte vor.

Kennz. Comp. No.	Benennung Designation	Sachnummer Stock No.	Hersteller Manufacturer	Bezeichnung Designation	enthalten in contained in	
	XX VARIANTENERKLAERUNG IDENTIFICATION OF MODELS VAR 02 = GRUNDAUSFUEHRUNG MOD 02 = BASIC MODEL					
A71	ED NETZTEIL POWER SUPPLY HIERZU STROML. 1062.5690S SEE CIRC.DIAGR.1062.5690S	1062.5902.02				
C1	CE 22000UF-10+50%16V36X45 ELECTROLYTIC CAPACITOR	0291.6209.00	PHILIPS_CO	2222 051 55223	1062.5902.01	
C2	CE 10UF +-10% 10V 6032 TANTALUM SMD-CAPACITOR	CE 0007.7281.00	KEMET	T491 C 106 K 010 AS	1062.5902.01	
C3	CE 10UF +-10% 10V 6032 TANTALUM SMD-CAPACITOR	CE 0007.7281.00	KEMET	T491 C 106 K 010 AS	1062.5902.01	
C4	CE 220UF+-20%10V RM2,5 ELECTROLYTIC CAPACITOR	CE 0008.7927.00	PANASONIC	ECA-1AFG221I	1062.5902.01	
C5	CE 220UF+-20%10V RM2,5 ELECTROLYTIC CAPACITOR	CE 0008.7927.00	PANASONIC	ECA-1AFG221I	1062.5902.01	
C8	CC 100NF+-10%50V X7R 1206 CERAMIC CHIP CAPACITOR	CC 0007.5237.00	PHILIPS_CO	2238 581 15649	1062.5902.01	
C20	CE 22MF+-20%25V35X55 ELECTROLYTIC CAPACITOR	0814.5642.00	VALVO	2222 051 56223	1062.5902.01	
C21	CE 10UF +-10% 25V 7343 TANTALUM SMD-CAPACITOR	CE 0007.7246.00	SPRAGUE	293D 106 X9 025 D2T	1062.5902.01	
C22	CE 100UF+-20%25V RM2.5 ELECTROLYTIC CAPACITOR	CE 0008.7891.00	PANASONIC	ECA-1EFG101I	1062.5902.01	
C28	CC 100NF+-10%50V X7R 1206 CERAMIC CHIP CAPACITOR	CC 0007.5237.00	PHILIPS_CO	2238 581 15649	1062.5902.01	
C30	CE 2,2MF+-20%50V RD30X25 ELECTROLYTIC CAPACITOR	0815.8197.00	NAT_PANASO	ECES1HU222J	1062.5902.01	
C31	CE 100UF+-20%63V RM5 ELECTROLYTIC CAPACITOR	CE 0008.7879.00	PANASONIC	ECA 1 JFG 101 BQ	1062.5902.01	
C38	CC 100NF+-10%50V X7R 1206 CERAMIC CHIP CAPACITOR	CC 0007.5237.00	PHILIPS_CO	2238 581 15649	1062.5902.01	
C40	CE 15MF+-20%25V RD35X30 ELECTROLYTIC CAPACITOR	0815.8145.00	PANASONIC	ECOS1EA153EA	1062.5902.01	
C42	CE 100UF+-20%25V RM2.5 ELECTROLYTIC CAPACITOR	CE 0008.7891.00	PANASONIC	ECA-1EFG101I	1062.5902.01	
C43	CE 10UF +-10% 25V 7343 TANTALUM SMD-CAPACITOR	CE 0007.7246.00	SPRAGUE	293D 106 X9 025 D2T	1062.5902.01	
C48	CC 100NF+-10%50V X7R 1206 CERAMIC CHIP CAPACITOR	CC 0007.5237.00	PHILIPS_CO	2238 581 15649	1062.5902.01	
E1	DX FAN UNIT FAN UNIT	1062.6715.00				
F1	SS SCHMELZ.T2,5HIEC127-2V FUUSE	SS 0020.7575.00	WICKMANN	T2.5 H NR.19181		
F2	SS SCHMELZ.T2,5HIEC127-2V FUUSE FUER/FOR 100/120V 220/230V	SS 0020.7575.00	WICKMANN	T2.5 H NR.19181		
F3 F.6	SS SCHMELZS.T4 IEC127-2/V FUUSE	SS 0020.7600.00	WICKMANN	T4 H NR.19181	1062.5902.01	
F7	ST TEMP.SICH. 150GRD 2,5A TEMPERATURFUUSE 150GRD	ST 0007.7200.00	WICKMANN	X25	1062.5977.00	
N1	BO LT1085CT +ADJ REGL IC VOLTAGE REGULATOR	2031.7680.00	LINEAR_TEC	LT1085CT	1062.5902.01	
N2	BO LT1085CT +ADJ REGL IC VOLTAGE REGULATOR	2031.7680.00	LINEAR_TEC	LT1085CT	1062.5902.01	
N20	BO LT1085CT +ADJ REGL IC VOLTAGE REGULATOR	2031.7680.00	LINEAR_TEC	LT1085CT	1062.5902.01	
N30	BO UA7824UC+24V1A0 VREGL VOLTAGE REGULATOR	BO 0336.4621.00	NSC	LM7824CT	1062.5902.01	
N40	BO LM317T +ADJ1A5 VREGL VOLTAGE REGULATOR	BO 0339.4080.00	NSC	LM-317T	1062.5902.01	
R1	RL 0,35W100 OHM+-0,1%TK25 RESISTOR	RL 0083.7220.00	DRALORIC	SMA0207	1062.5902.01	
R2	RL 0,35W499 OHM+-0,1%TK25 RESISTOR	RL 0083.8562.00	RESISTA	MK2	1062.5902.01	
R4	RL 0,35W121 OHM+-0,1%TK25 RESISTOR	RL 0083.7389.00			1062.5902.01	
R5	RL 0,35W374 OHM+-0,1%TK25 RESISTOR	RL 0083.8327.00	RESISTA	MK2	1062.5902.01	
MENP5	413 3PUA	Äl	Datum Date	Schaltteilliste für Parts list for	Sachnummer Stock No.	Blatt-Nr. Page
	ROHDE & SCHWARZ	01	16.09.97	ZE NETZTEIL, EINHEIT POWER SUPPLY	1062.5690.01 SA	1+

095.0026-0693

Kennz. Comp. No.	Benennung Designation	Sachnummer Stock No.	Hersteller Manufacturer	Bezeichnung Designation	enthalten in contained in
R8	RG 10,0 OHM+-1%TK100 1206 CHIP -RESISTOR	RG 0006.8649.00	DRALORIC	CR(B) 1206...	1062.5902.01
R20	RL 0,35W100 OHM+-0,1%TK25 RESISTOR	RL 0083.7220.00	DRALORIC	SMA0207	1062.5902.01
R21	RL 0,35W1,10KOHM+-0,1%T25 RESISTOR	RL 0083.9223.00	DRALORIC	SMA0207	1062.5902.01
R28	RG 10,0 OHM+-1%TK100 1206 CHIP -RESISTOR	RG 0006.8649.00	DRALORIC	CR(B) 1206...	1062.5902.01
R38	RG 10,0 OHM+-1%TK100 1206 CHIP -RESISTOR	RG 0006.8649.00	DRALORIC	CR(B) 1206...	1062.5902.01
R40	RL 0,35W100 OHM+-0,1%TK25 RESISTOR	RL 0083.7220.00	DRALORIC	SMA0207	1062.5902.01
R41	RL 0,35W1,10KOHM+-0,1%T25 RESISTOR	RL 0083.9223.00	DRALORIC	SMA0207	1062.5902.01
R48	RG 10,0 OHM+-1%TK100 1206 CHIP -RESISTOR	RG 0006.8649.00	DRALORIC	CR(B) 1206...	1062.5902.01
R90	RK HEISSL.100KOHM10% 0,5W THERMISTOR	0520.5983.00	SIEMENS	B57164-K104-K	1062.5902.01
S1	SB NETZSCHALTER 2XU 0.KN. POWER SWITCH	SB 0007.5143.00	ITT-SEL	NE18 2U E E	
T1	LT RINGKERNTRAFD SMY TRANSFORMER	1062.5977.00			
V1	AG B80C5000/3300 BRGL RECTIFIER	AG 0084.5109.00	TELEFUNKEN	B80C5000/3300SI	1062.5902.01
V20	AG B80C5000/3300 BRGL RECTIFIER	AG 0084.5109.00	TELEFUNKEN	B80C5000/3300SI	1062.5902.01
V30	AG B250C1500 BRGL RECTIFIER	AG 0208.2340.00	GEN_INSTRU	B380C1500	1062.5902.01
V40	AG B80C5000/3300 BRGL RECTIFIER	AG 0084.5109.00	TELEFUNKEN	B80C5000/3300SI	1062.5902.01
V41	AG 1N4007 GL1000V 1A0 RECTIFIER	AG 0013.0310.00	ITT-SEMICO	1N4007	1062.5902.01
X2	FP STECKERLEISTE 5P.GER CONNECTOR 5P	FP 1026.3132.00	J_S_T_DEUT	B5P-VH-B	1062.5902.01
X3	FP STECKERLEISTE 4P.GER CONNECTOR	FP 1026.3055.00	J_S_T_DEUT	B4P-VH-B	1062.5902.01
X4	FP STIFTLAISTE 36P.R2,54 PIN CONNECTOR 4-POLIG	FP 0242.3600.00	BINDER	742-11-0179-00-36	1062.5902.01
X21	FP STECKERLEISTE 26P.GER CONNECTOR 26P.	FP 0820.8610.00	SIEMENS	V23535-A2200-A262	1062.5902.01
X22	FP STECKERLEISTE 16P.GER CONNECTOR	FP 4007.2304.00	SIEMENS	V23535-A2200-A162	1062.5902.01
Z1	FN EURO-ST.M.NETZFILTER4A FILTER W.VOLTAGESLECTION	FN 0006.0919.00	CORCOM	F-7364D	

In dieser Unterlegungszeichnung
 wir uns alle Rechte vor.

095.002B-0693

MENP5	413 3PUA	Äi	Datum Date	Schaltteilliste für Parts list for	Sachnummer Stock No.	Blatt-Nr. Page
		01	16.09.97	ZE NETZTEIL, EINHEIT POWER SUPPLY	1062.5690.01 SA	2-



XY-Liste

XY List

Erklärung der Spaltenbezeichnungen:

- Part:** Bauelement-Kennzeichen.
- Side:** Leiterplatten-Seite, auf der sich das Bauelement befindet.
- XY:** Koordinaten (Millimeter) des Bauelementes auf der Leiterplatte bezogen auf den Nullpunkt.
- SQR, PG:** Planquadrat und Seite des Schaltbildes für das jeweilige Bauelement.

Explanation of column designations:

- Part:** Identification of instrument part.
- Side:** Side of the PC board on which instrument part is positioned.
- XY:** Coordinates (millimeter) of the component on the PC board in reference to zero point.
- SQR, PG:** Square and page of the diagram for the respective instrument part.

Service-Relevante Bauteile / Service-Relevant Components																	
Part	Side	X	Y	Sqr	Pg	Part	Side	X	Y	Sqr	Pg	Part	Side	X	Y	Sqr	Pg
F3	B	22	32	2F	2	F6	B	37	50	2C	2	X4	B	10	67	2B	2
F4	B	22	18	2E	2	X2	B	13	37	2F	2	X21	B	132	5	7E	2
F5	B	22	58	2D	2	X3	B	35	70	2C	2	X22	B	99	5	6B	2
Nicht-Service-Relevante Bauteile / Non-Service-Relevant Components																	
Part	Side	X	Y	Sqr	Pg	Part	Side	X	Y	Sqr	Pg	Part	Side	X	Y	Sqr	Pg
C1	B	95	26	3E	2	C43	A	139	58	4B	2	R8	A	72	4	2F	2
C2	A	161	58	4E	2	C48	A	6	46	2C	2	R20	B	125	60	4E	2
C3	A	150	58	5E	2	GND1	B	132	21	6E	2	R21	B	117	60	4D	2
C4	B	161	86	4F	2	GND2	B	139	39	6D	2	R28	A	27	4	2E	2
C5	B	153	86	5F	2	GND3	B	127	7	6C	2	R38	A	43	65	2D	2
C8	A	65	4	2F	2	GND4	B	152	22	6C	2	R40	B	143	60	4C	2
C20	B	95	70	3D	2	N1	B	162	94	3F	2	R41	B	135	60	4C	2
C21	A	121	58	4D	2	N2	B	150	94	4F	2	R48	A	6	39	2C	2
C22	B	121	86	4D	2	N20	B	116	94	3E	2	R90	B	114	58	2B	2
C28	A	21	4	2D	2	N30	B	128	94	3D	2	V1	B	81	8	2F	2
C30	B	59	85	3C	2	N40	B	139	94	3C	2	V20	B	36	8	2E	2
C31	B	135	79	4C	2	R1	B	164	60	4F	2	V30	B	44	73	2D	2
C38	A	46	67	2C	2	R2	B	158	60	4E	2	V40	B	3	30	2C	2
C40	B	54	33	3C	2	R4	B	154	60	5F	2	V41	B	148	40	5C	2
C42	B	142	86	4C	2	R5	B	147	60	5E	2	VCC1	B	155	26	6B	2

ROHDE & SCHWARZ	ÄI	Datum Date	XY-Liste für XY-list for	Sach-Nummer Stock-Nr	Blatt Page
	03	23.08.94	ED NETZTEILEINHEIT POWER_SUPPLY_UNIT	1062.5902.01 XY	1-





ROHDE & SCHWARZ

Stromläufe
Bestückungspläne
Circuit diagrams
Components plans
Schémas de circuit
Plans des composants

T1
TRAFO

RECTIFIERS
AND
VOLTAGE
REGULATORS

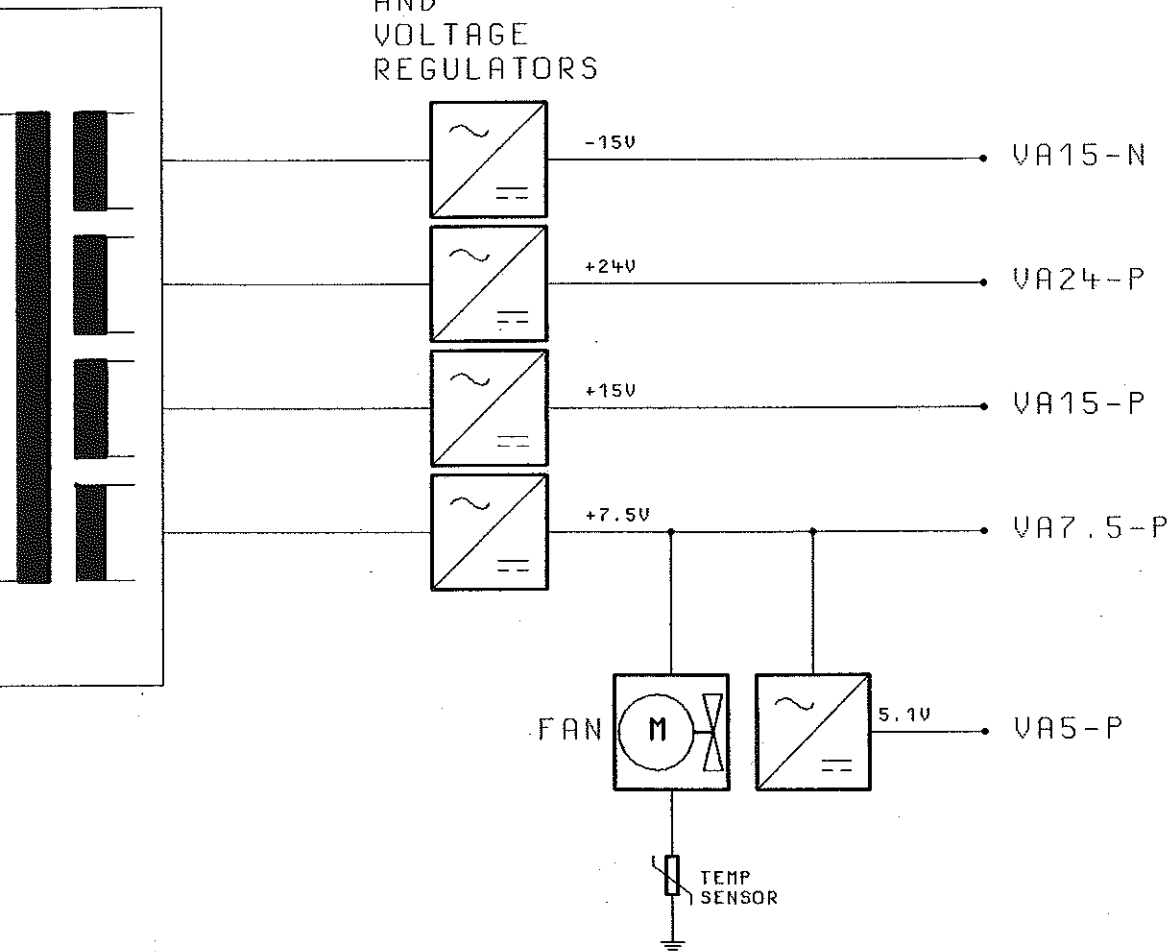

STROMLAUF GILT FUER VAR.02
CIRCUIT DIAGRAM IS VALID FOR MOD.02

03/	49165	11.04.95	HM	1GPK	TAG	NAME	BENENNUNG	
				BEARB.		HM	NETZTEILEINHEIT POWER SUPPLY UNIT	
				GEPR.				
				NORN				
				PLOTT	11.04.95			
				 ROHDE & SCHWARZ			ZEICHN.-NR.	BLATT-NR.
								1062.5690.015
REND. IND.	ÄNDERUNGS- MITTEILUNG	DATUM	NAME	ZU GERÄT	SMY	REG. I. V.	1062.5502	ERSTE Z.

TE
NE
VICES
IG

F
E
D
C
B
A

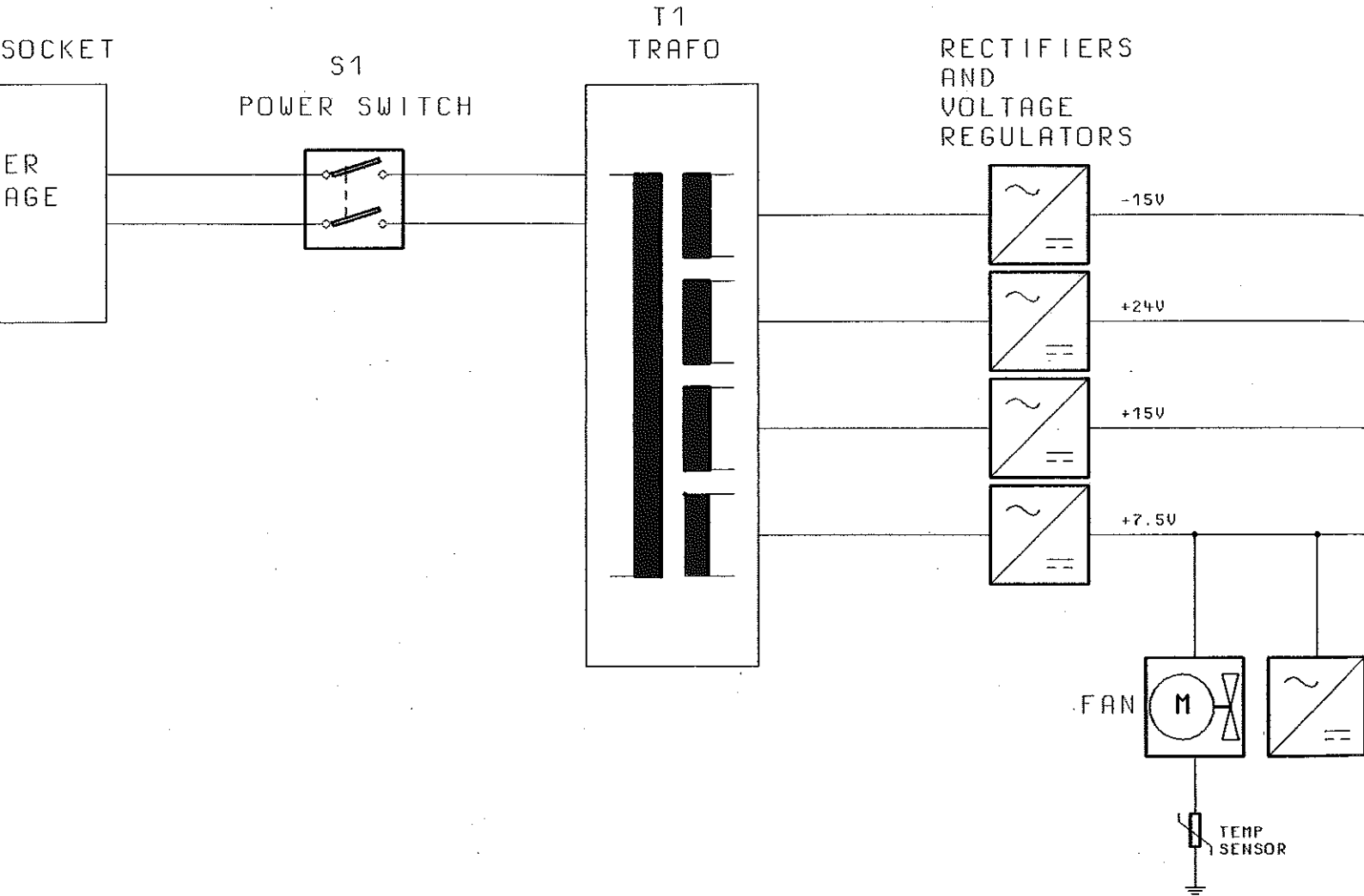

STROMLAUF GILT FUER V
CIRCUIT DIAGRAM IS VALID FOR MOD

 ACHTUNG: EGB!
ELEKTROSTATISCH GEFÄHRDETE
BAUELEMENTE ERFORDERN EINE
BESONDERE HANDHABUNG.
ATTENTION ESD!
ELECTROSTATIC SENSITIVE DEVICES
REQUIRE A SPECIAL HANDLING

03/	49165	11.04.95	HM	1GPK	TAG	NAME	BE
				BEARB.		HM	
				GEPR.			
				NORM			
				PLOTT	11.04.95		
/							ZE
REND. IND.	ÄNDERUNGS- MITTEILUNG	DATUM	NAME	 ROHDE & SCHWARZ			RE
						ZU GERÄT	SMY

3

4

5

6

7

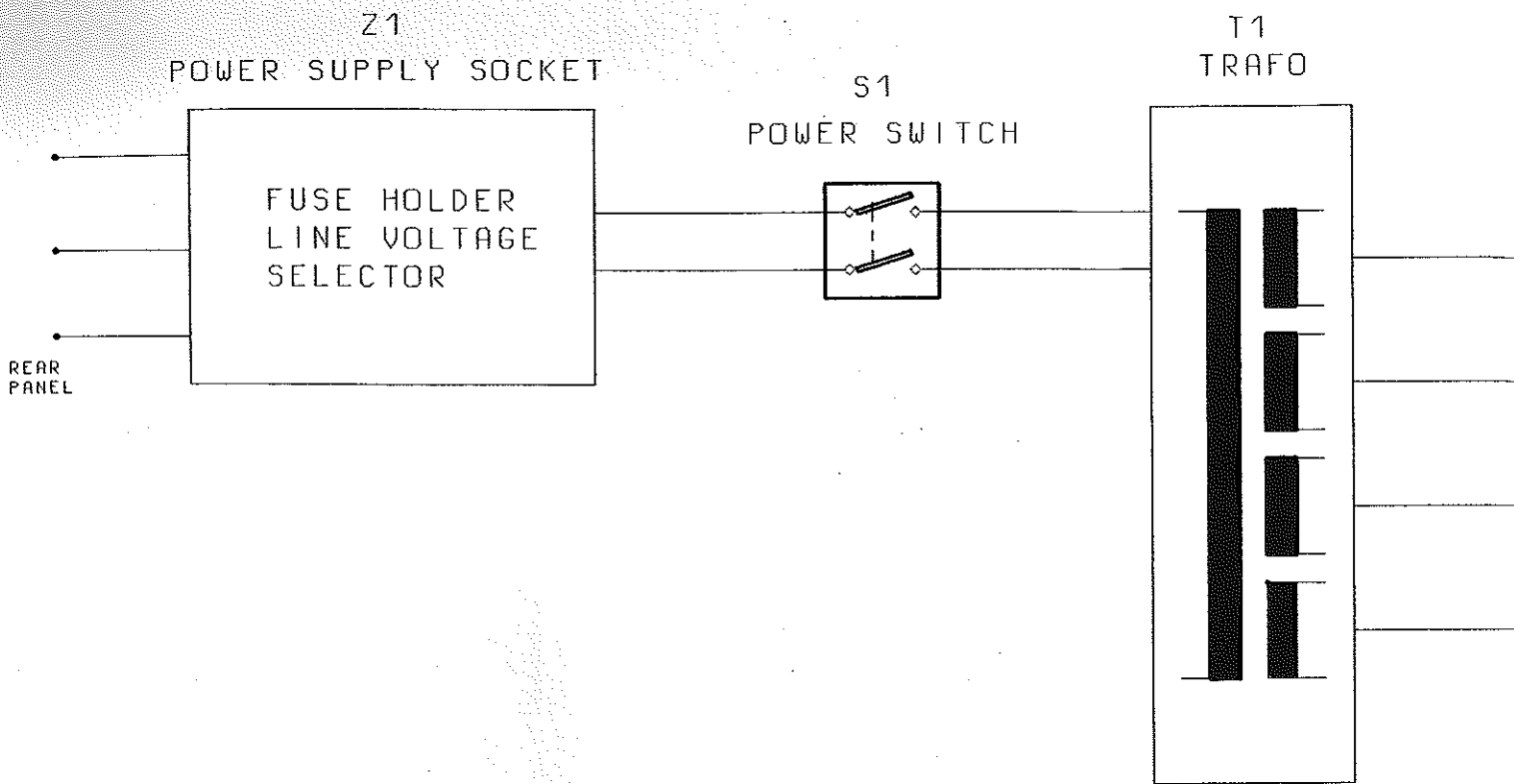

ACHTUNG: EGB!
 ELEKTROSTATISCH GEFÄHRDETE
 BAUELEMENTE ERFORDERN EINE
 BESONDERE HANDHABUNG.
ATTENTION ESD!
 ELECTROSTATIC SENSITIVE DEVICES
 REQUIRE A SPECIAL HANDLING.

03/	49165
REND. IND.	RENDERUNGS- MITTEILUNG

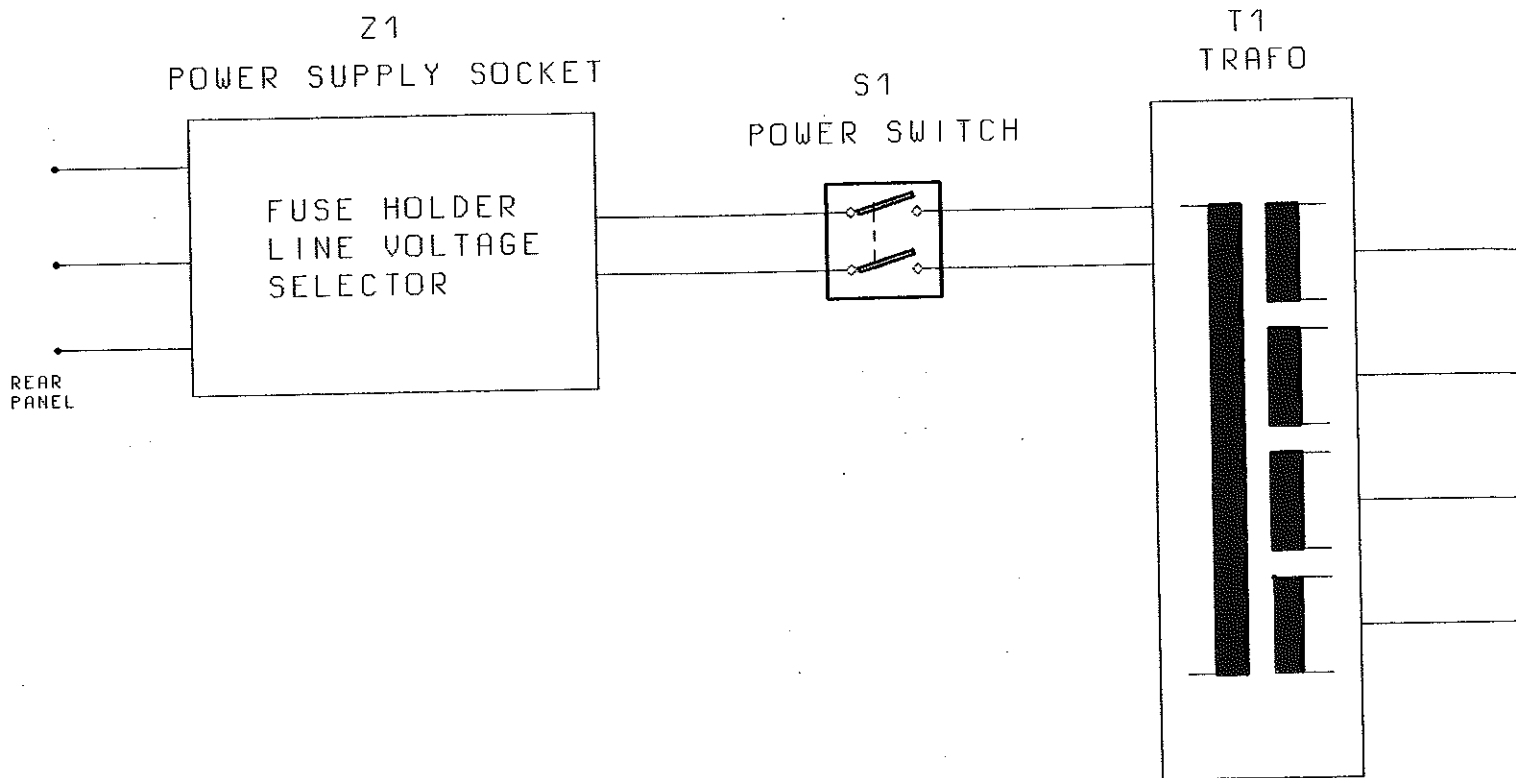

ACHTUNG: EGB!
 ELEKTROSTATISCH GEFÄHRDETE
 BAUELEMENTE ERFORDERN EINE
 BESONDERE HANDHABUNG.
ATTENTION ESD!
 ELECTROSTATIC SENSITIVE DEVICES
 REQUIRE A SPECIAL HANDLING

03/	49165
REND. IND.	RENDERUNGS MITTEILUNG

F
E
D
C
B
A

FÜR DIESE UNTERLAGE
BEHALTEN WIR UNS ALLE RECHTE VOR

ZEICHN.-NR.

Z1
POWER SUPPLY SOCKET

S1
POWER SWITCH

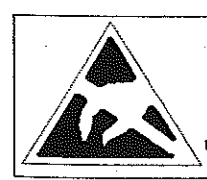
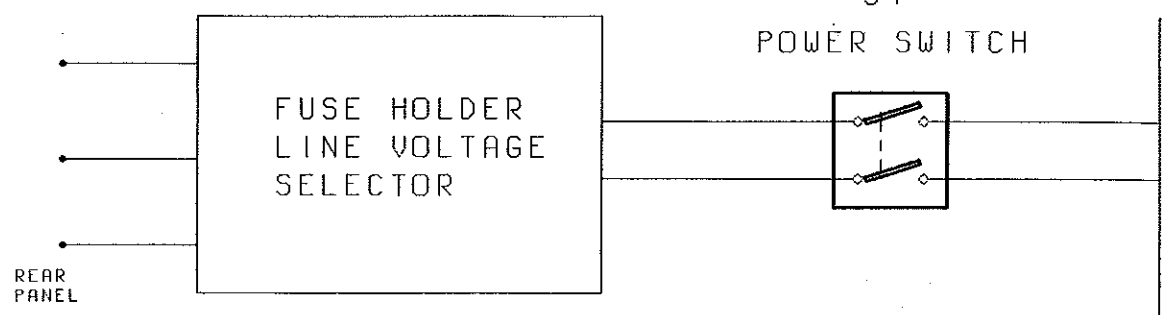

ACHTUNG: EGB!
ELEKTROSTATISCH GEFÄHRLICHE
BAUELEMENTE ERFORDERN EIN
BESONDERE HANDHABUNG.
ATTENTION ESD!
ELECTROSTATIC SENSITIVE DE
REQUIRE A SPECIAL HANDL

1 2 3 4

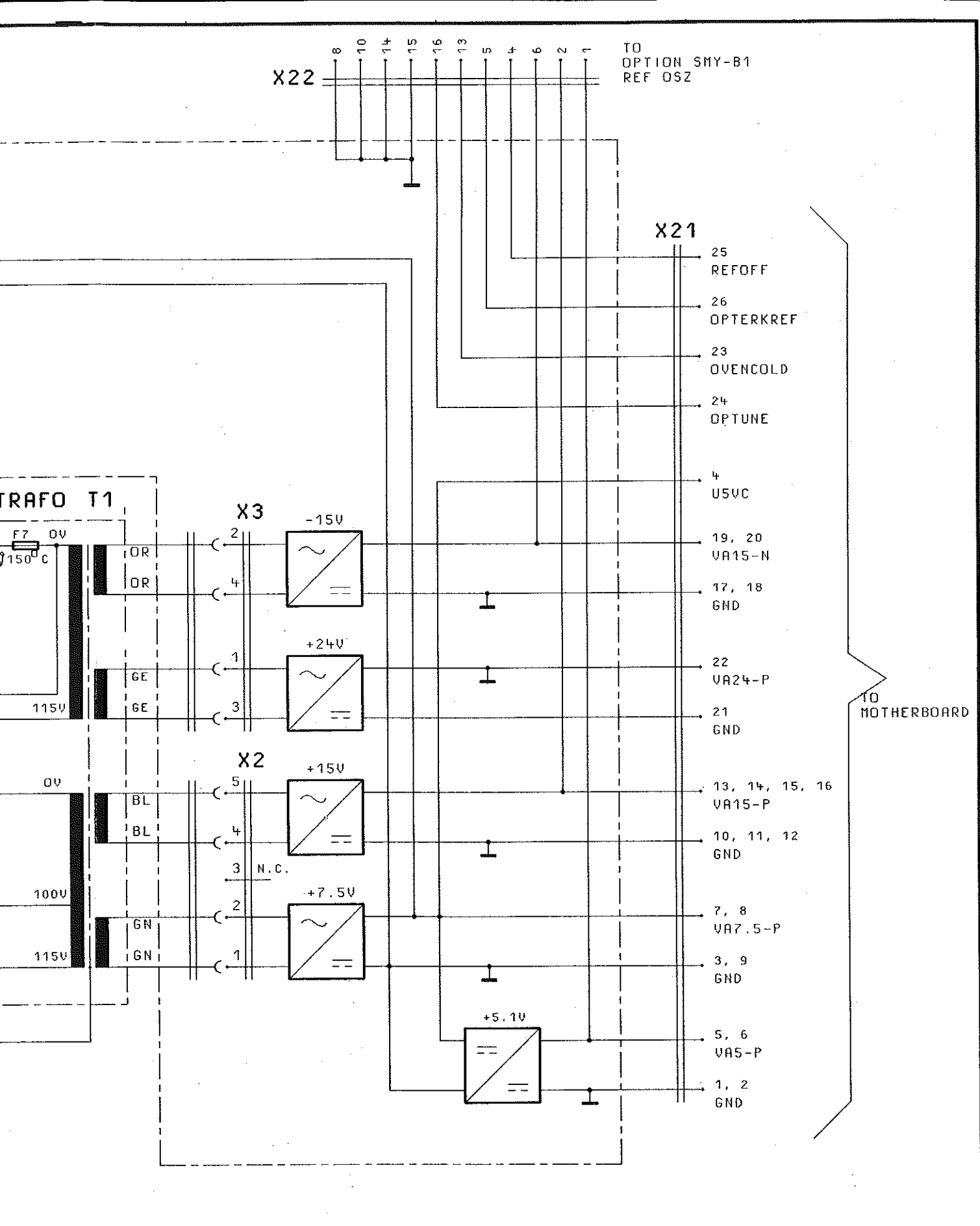

031	49165	04.95	HM	3CD	TAG	NAME	BENENNUNG
				BEARB.		ROD	NETZTEILEINHEIT POWER SUPPLY UNIT
				GEPR.			
				NORM			
				PLOTT	11.04.95		
				 ROHDE & SCHWARZ		ZEICHN.-NR.	BLATT-NR.
						1062.5690.015	2-
REND. IND.	ÄNDERUNGS-MITTEILUNG	DATUM	NAME	ZU GERÄT	SMY	REG. I. V.	ERSTE Z.
						1062.5502	



BOARD
A71
1062.5902

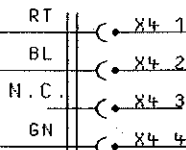

TRAFU T1

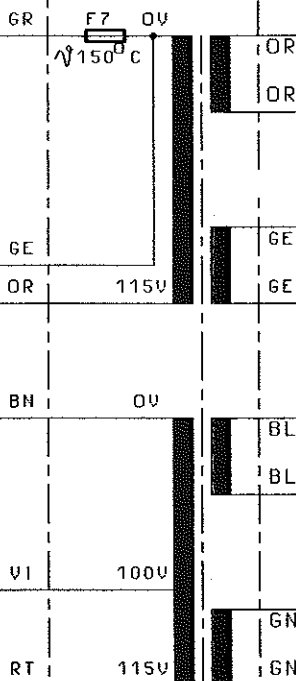

X3

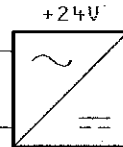
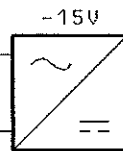

X2

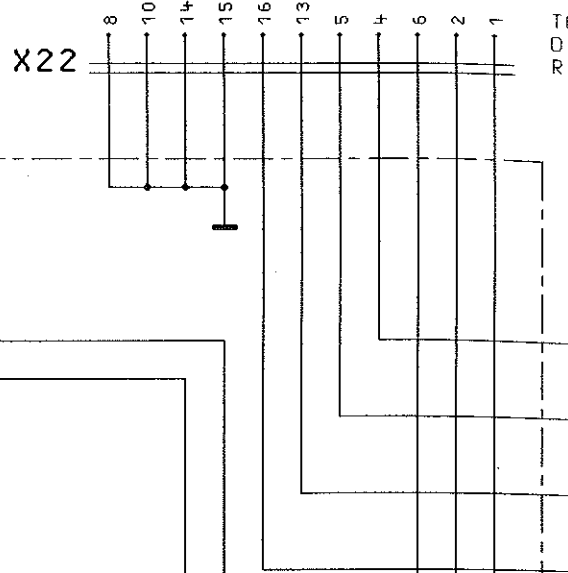
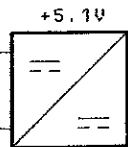
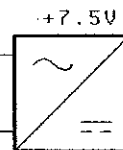
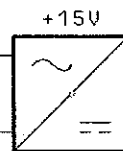

STROMLAUF GILT FUER VAR.02
CIRCUIT DIAGRAM IS VALID FOR MOD.02



ACHTUNG: EGB!
ELEKTROSTATISCH GEFÄHRDETE
BAUELEMENTE ERFORDERN EINE
BESONDERE HANDHABUNG.
ATTENTION ESD!
ELECTROSTATIC SENSITIVE DEVICES
REQUIRE A SPECIAL HANDLING

031	49165	04.95	HM	3CD	TAG	NAME	BENENNUNG
				BEARB.		ROD	NET. POWER
				GEPR.			
				NDRH			
				PLOTT	11.04.95		ZEICHN.-NR.
REND. IND.	ÄNDERUNGS- MITTEILUNG	DATUM.	NAME			ZU GERÄT	SMY

X22

0V	120V	220V	230V
CE	BCE	AB	BD
2.5 H	T 2.5 H		
2.5 H	T 2.5 H		

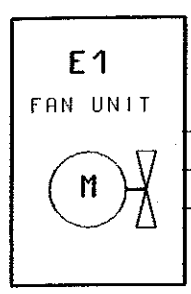

BOARD
A71
1062.5902

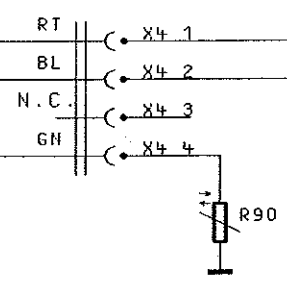

S1

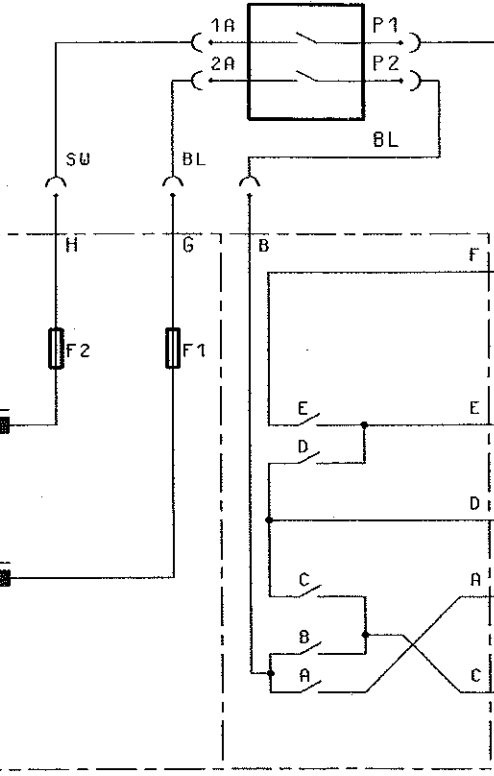

TRAFO T1

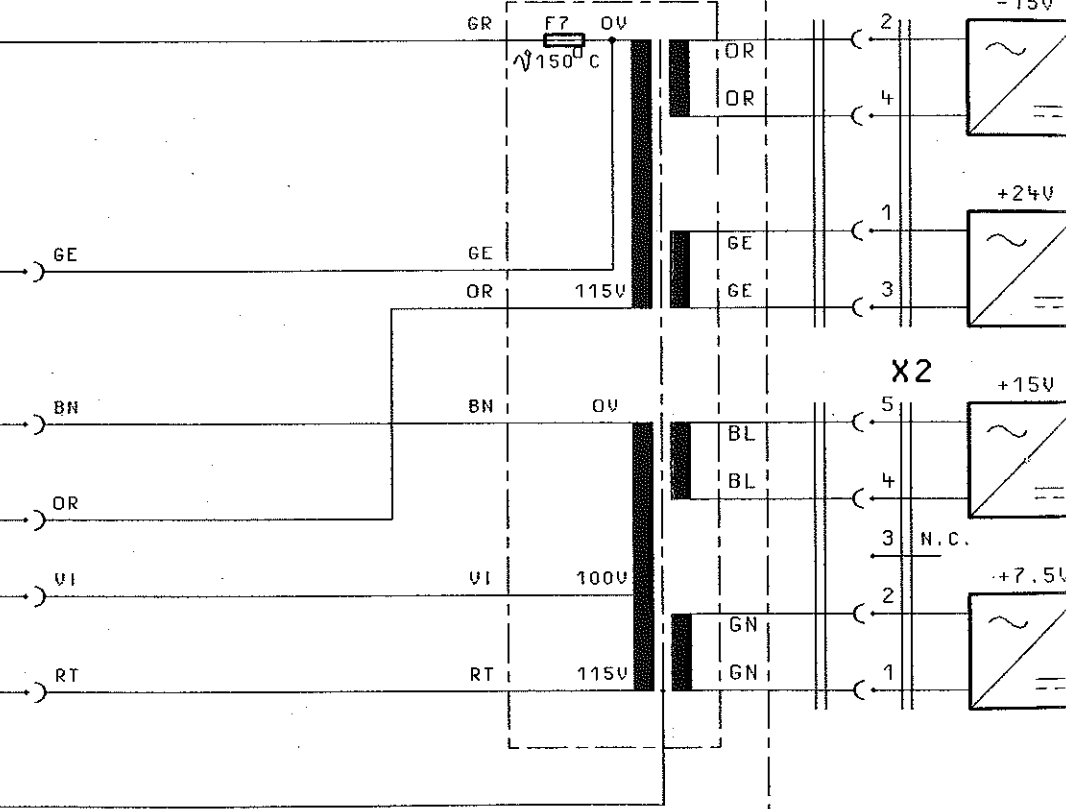

X3

X2

STROMLAUF GILT FUER VAR.02
CIRCUIT DIAGRAM IS VALID FOR MOD.02

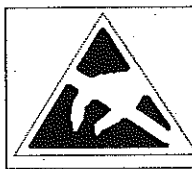

ACHTUNG: EGB!
ELEKTROSTATISCH GEFÄHREDETE
BAUELEMENTE ERFORDERN EINE
BESONDERE HANDHABUNG.
ATTENTION: ESD!
ELECTROSTATIC SENSITIVE DEVICES
REQUIRE A SPECIAL HANDLING

031	49165	04.95	HM	3C
				BER
				GEP
				NOR
				PLD
				R
REND.	RENDERUNGS-	DATUM	NAM	R
IND.	NITTEILUNG.			ZU

SPANNUNG VOLTAGE	100V	120V	220V	230V
SCHALTER GESCHLOSSEN SWITCH CLOSED	ACE	BCE	AB	BD
F1	IEC127	T 2.5 H	T 2.5 H	
F2	IEC127	T 2.5 H	T 2.5 H	

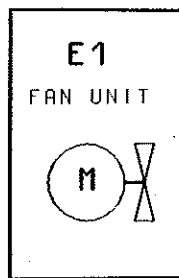

BOARD
A71
1062.5902

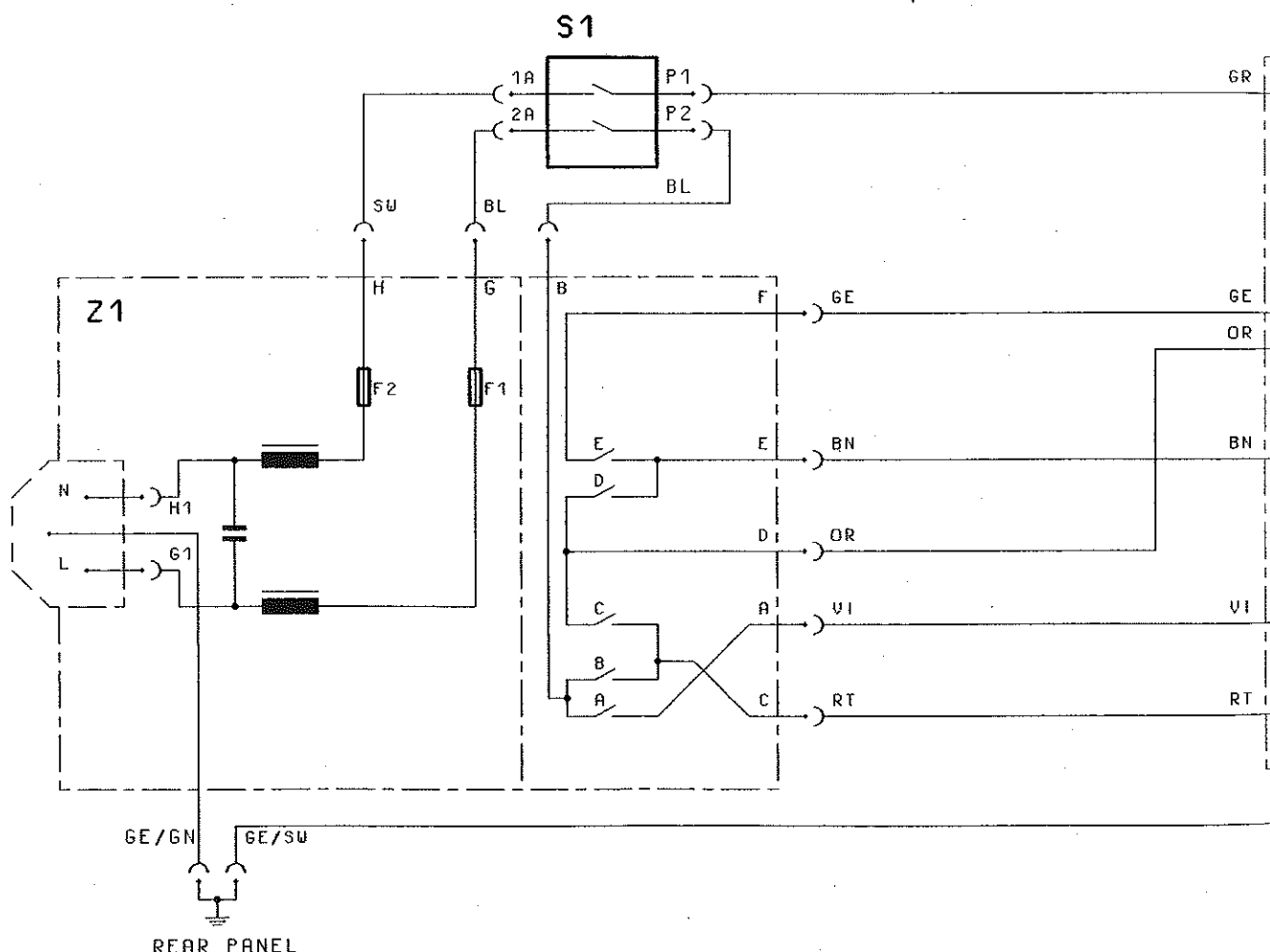
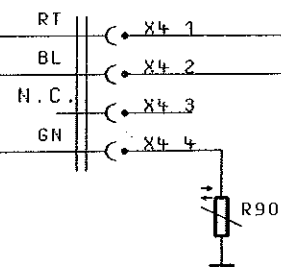

STROMLAUF GILT FUER VA
CIRCUIT DIAGRAM IS VALID FOR MOD.

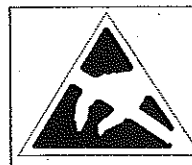

ACHTUNG: EGB!
ELEKTROSTATISCH GEFÄHRD
BAUELEMENTE ERFORDBRN E
BESONDERE HANDABUNG.
ATTENTION ESD!
ELECTROSTATIC SENSITIVE DE
REQUIRE A SPECIAL HANDL

FUER DIESE UNTERLAGE
BEHALTEN WIR UNS ALLE RECHTE VOR

ZEICHN.-NR. 1062.5690.01 S

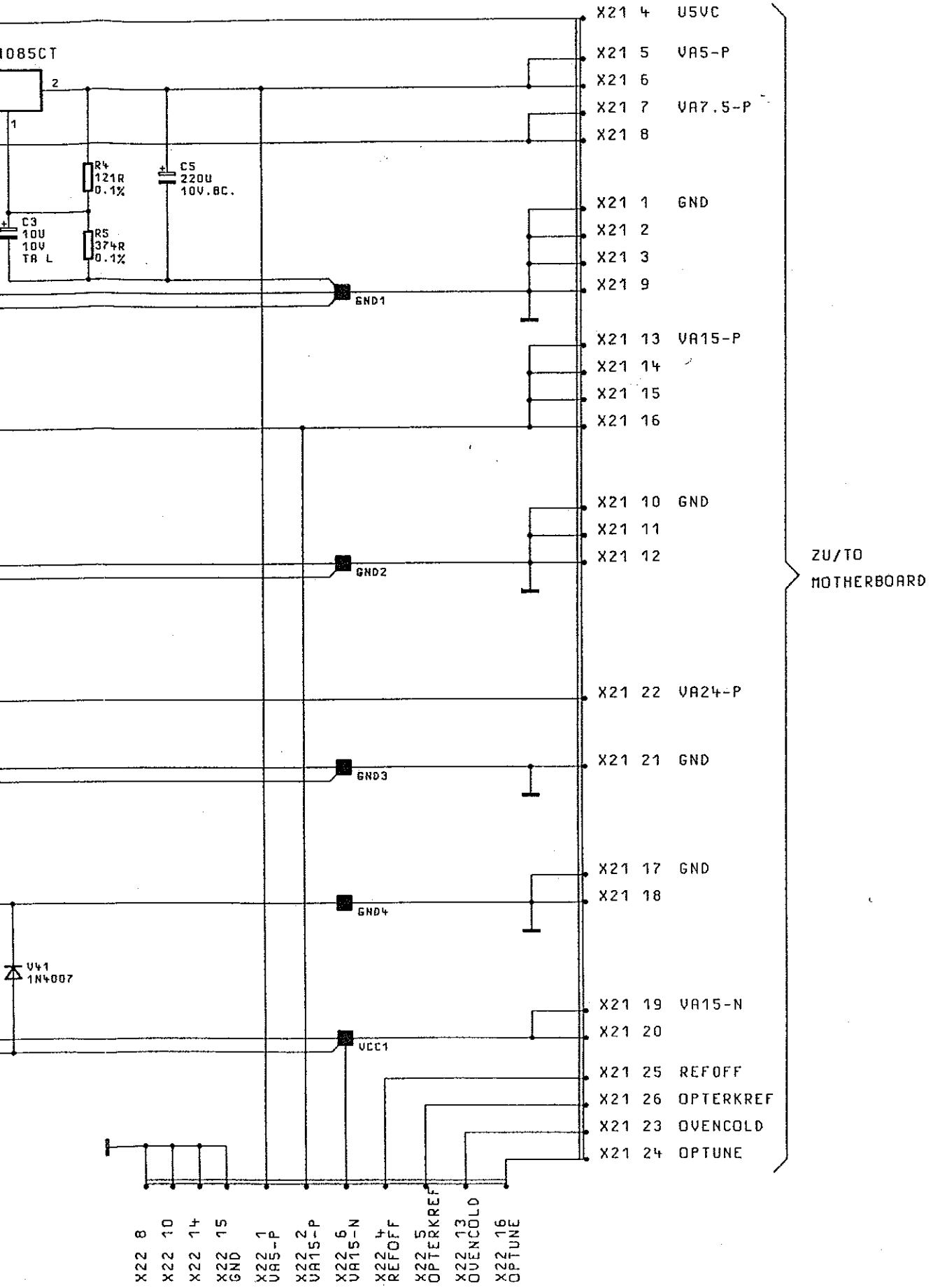

ZU/TO
MOTHERBOARD

- X22 8
- X22 10
- X22 14
- X22 15
- X22 GND
- X22 1 VA5-P
- X22 2 VA15-P
- X22 6 VA15-N
- X22 7 REFOFF
- X22 5 OPTERKREF
- X22 13 OVENCOLD
- X22 16 OPTUNE

01/02	48169 07	14.09.93	BU	1GPK	TAG	NAME	BENENKUNG	
				BEARB.		BU	NETZTEILEINHEIT POWER SUPPLY UNIT	
				GEPR.		BU		
				NORM				
				PLOTT	07.04.94			
01/01			BU	ROHDE & SCHWARZ			ZEICHN.-NR.	BLATT-NR.
REND. IND.	BEREHRUNGS-MITTEILUNG	DATUM	NAME					1062.5690.015
			ZU GERÄT	SMY	REC. 1. V.	1062.5502	ERSTE Z.	BL.

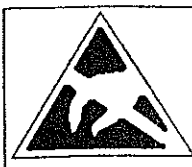
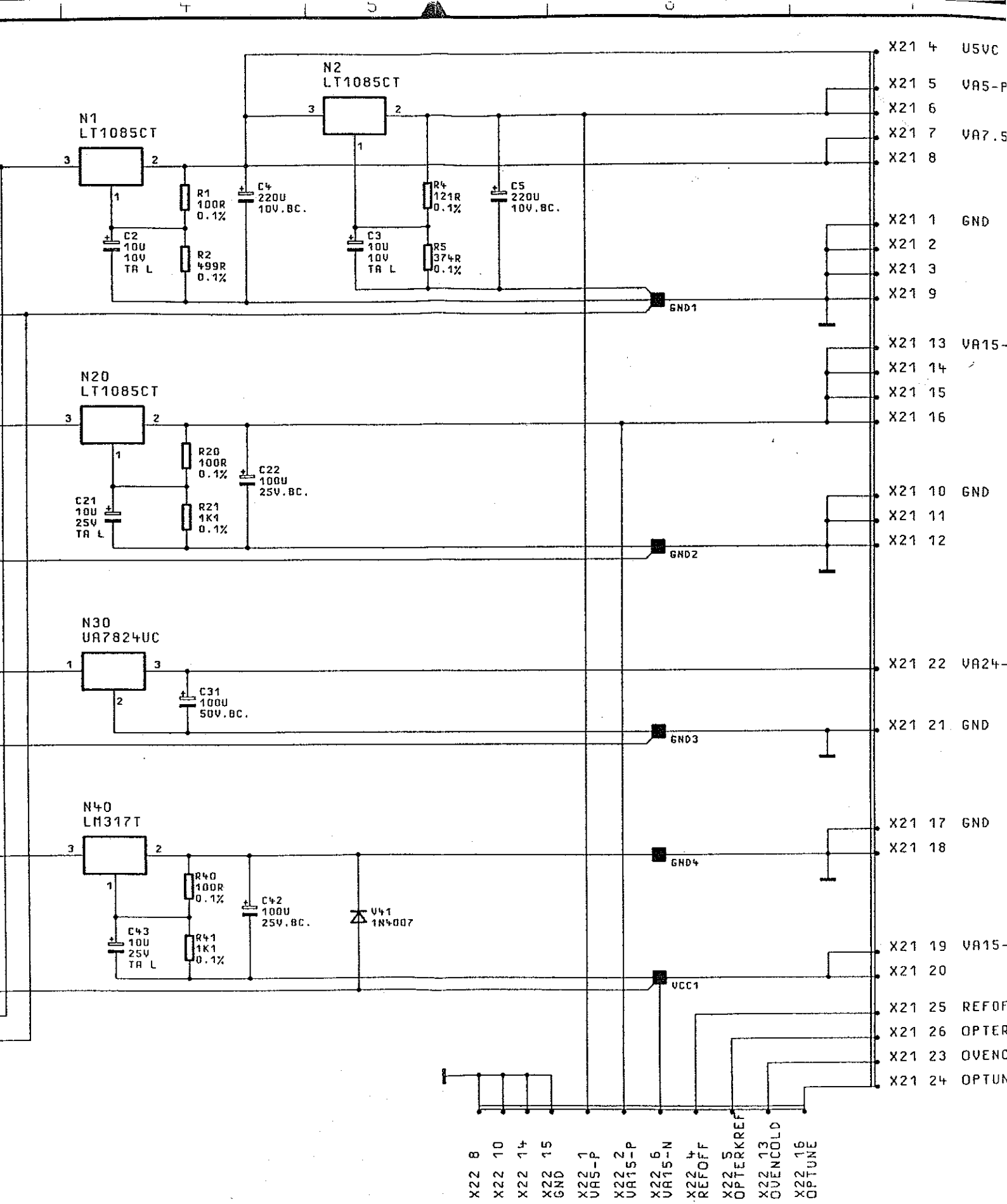

ACHTUNG: EGB!
 ELEKTROSTATISCH GEFÄHRDETE
 BAUELEMENTE ERFORDERN EINE
 BESONDERE HANDHABUNG.
ATTENTION ESD!
 ELECTROSTATIC SENSITIVE DEVICES
 REQUIRE A SPECIAL HANDLING

01/02	48169 07	14.09.93	BU	1GPK	TAG	NAME	BENENNUNG
				BEARB.		BU	NETZT POWER S
				GEPR.		BU	
				NORM			
				PLOTT	07.04.94		
01/01			BU	ROHDE & SCHWARZ			ZEICHN.-NR.
REND. IND.	RENDERUNGS- MITTEILUNG	DATUM	NAME				ZU GERÄT

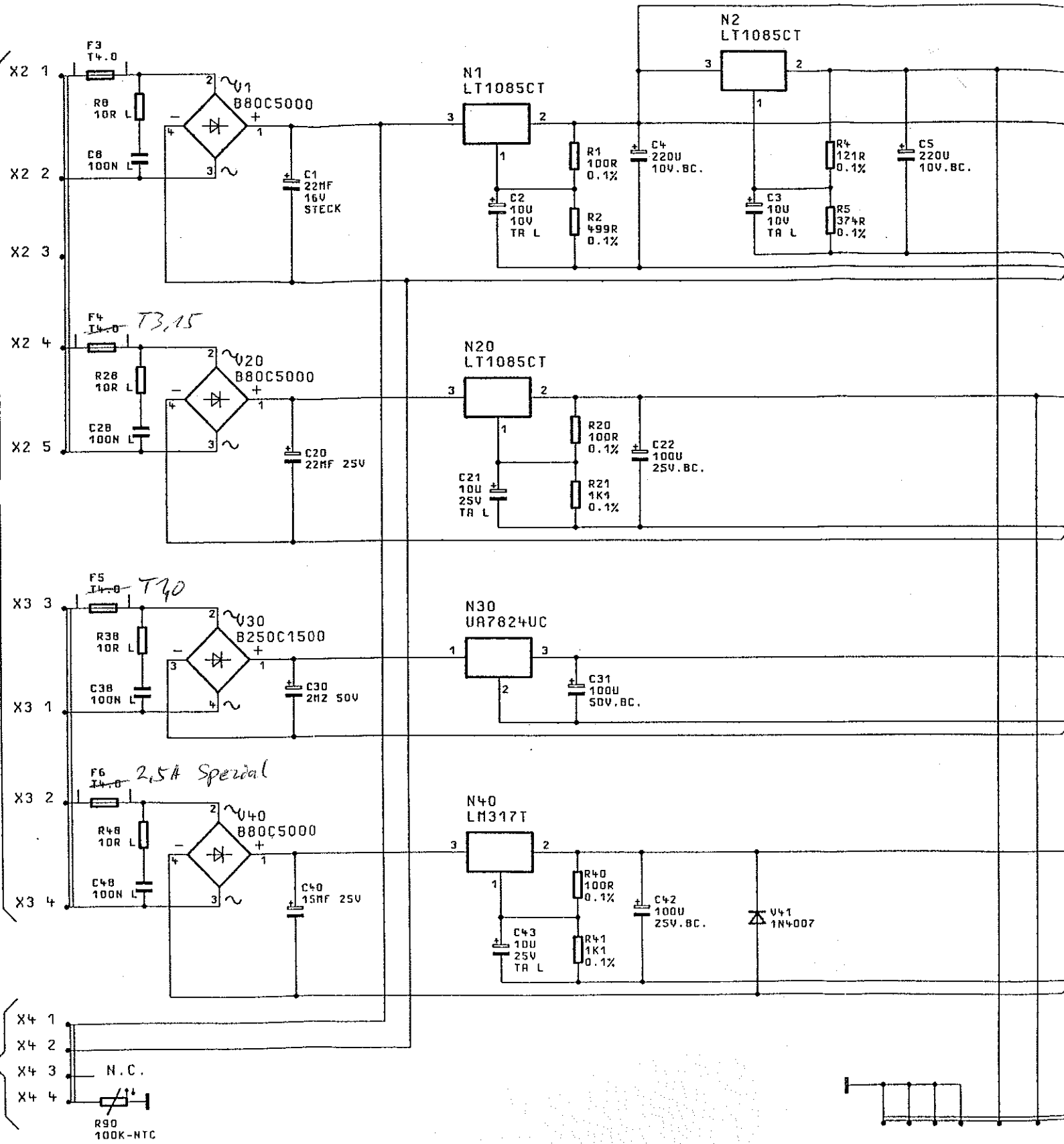

X22 8
X22 10
X22 14
X22 15
GND
X22 1
X22 2-P
X22 2-P

ROMLAUF GILT FUER VAR.02
 CUIT DIAGRAM IS VALID FOR MOD.02



ACHTUNG: EGB!
 ELEKTROSTATISCH GEFÄHRDETE
 BAUELEMENTE ERFORDERN EINE
 BESONDERE HANDHABUNG.
ATTENTION ESD!
 ELECTROSTATIC SENSITIVE DEVICES
 REQUIRE A SPECIAL HANDLING

01/02	48169 07	14.09.93
01/01		
REND. IND.	RENDERUNGS- MITTEILUNG	DATUM

FUER DIESE UNTERLAGE
BEHALTEN WIR UNS ALLE RECHTE VOR

ZEICHN.-NR. 2.5902.01 S

ZU/TO
T1

ZU/TO
FAN

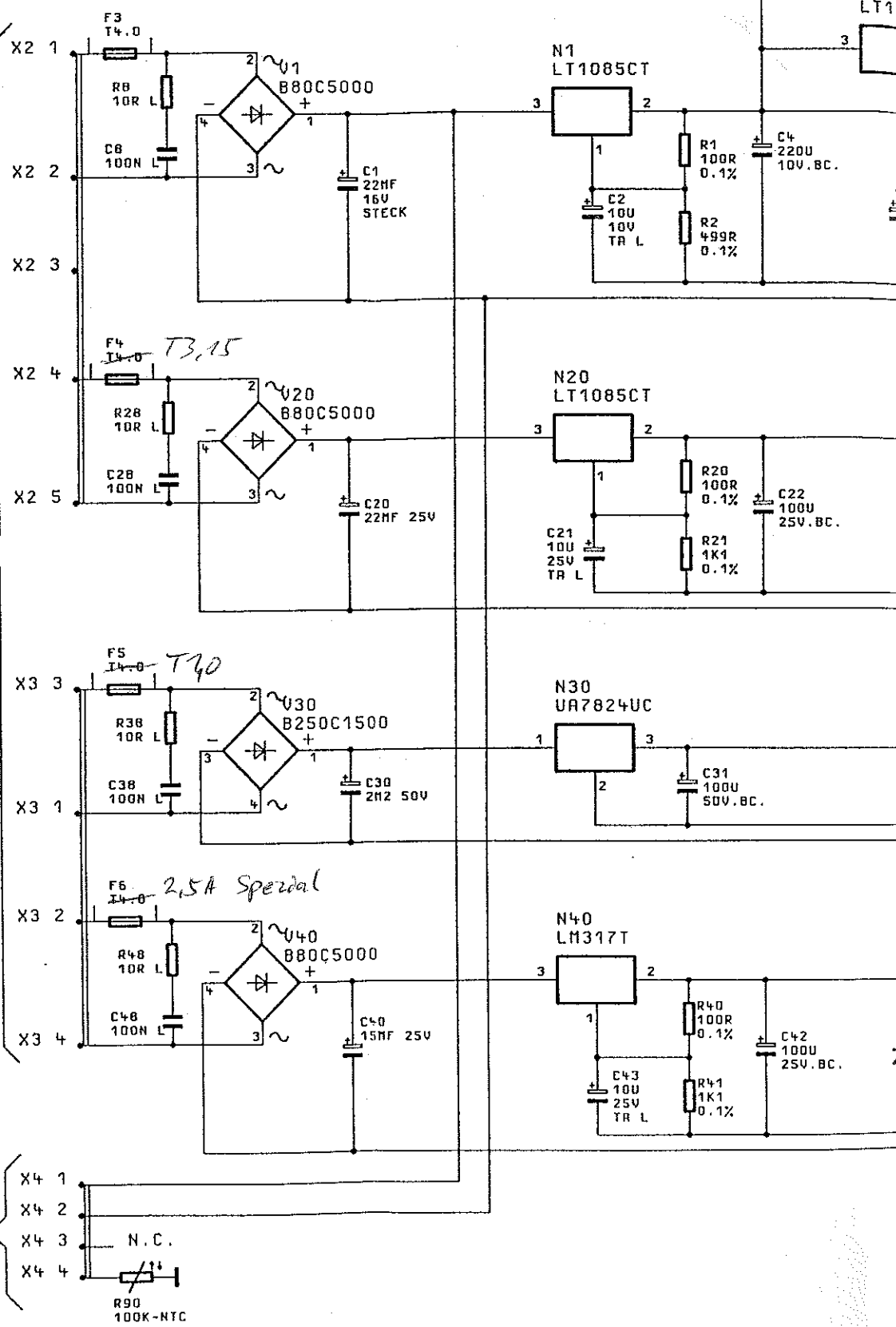

STROMLAUF GILT FUER VAR.02
CIRCUIT DIAGRAM IS VALID FOR MOD.02

ACHTUNG: EGB!
ELEKTROSTATISCH GEFAHRDETE
BAUELEMENTE ERFOROERN EINE
BESONDERE HANDHABUNG.
ATTENTION ESD!
ELECTROSTATIC SENSITIVE DEVICES
REQUIRE A SPECIAL HANDLING

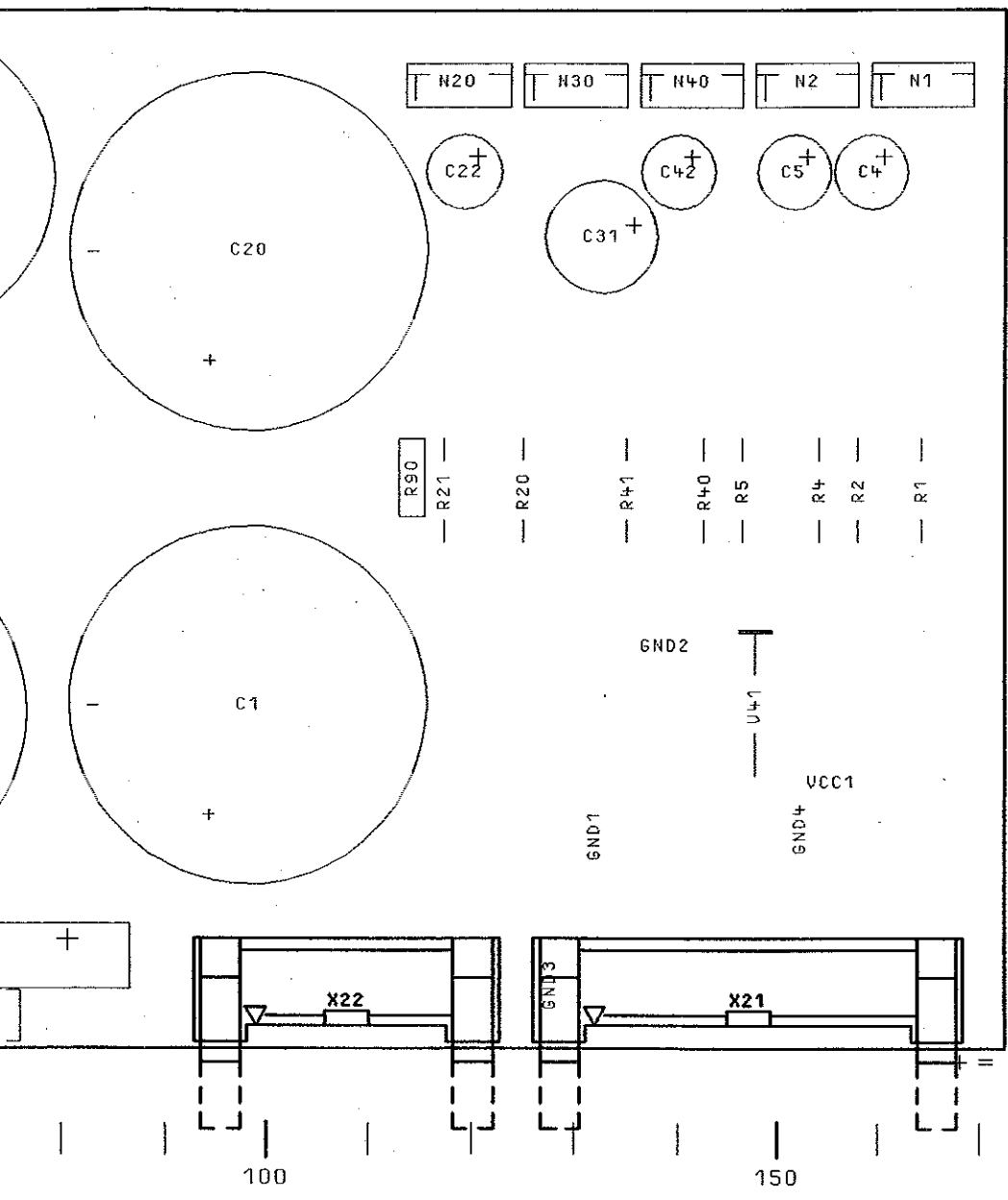

03/	48169	23.08.94	BU	1GPK	TAG	NARE	BENENNUNG		Z
				BEARB.		BU	NETZTEILEINHEIT		
				GEPR.			POWER SUPPLY UNIT		
				NORR					
				PLOTT	24.08.94				
				 ROHDE & SCHWARZ		ZEICHN.-NR.		BLATT-NR.	
REND. IND.	RENDERUNGS-NITTEILUNG	DATUM	NARE			1062.5902.01		ED	1+
				ZU GERÄT	SMY	PEG. I. V.	1062.5502	ERSTE Z.	U. BL.

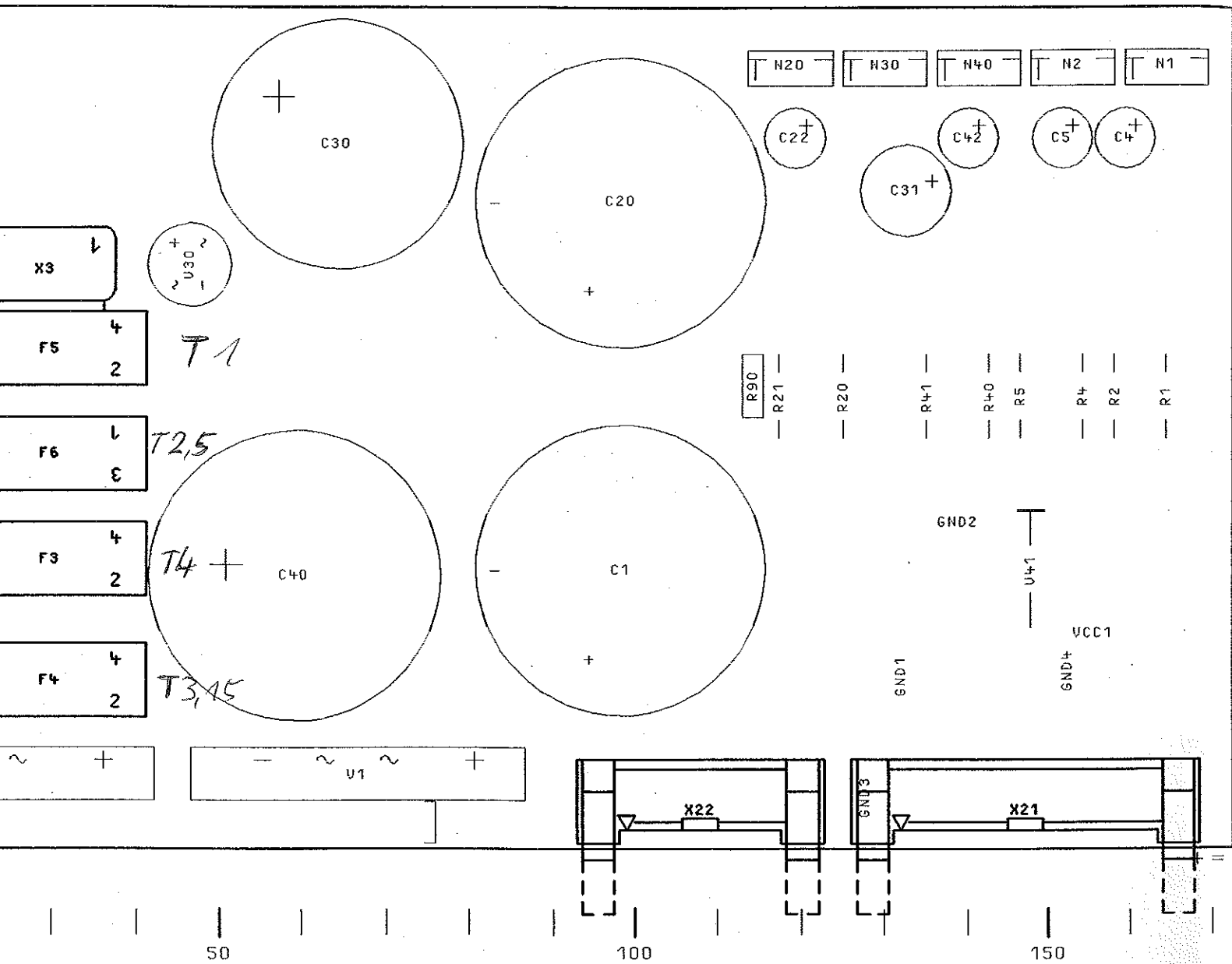

GB!
 FREIHANDLUNG
 DER EINE
 HANDBLATT
 SD!
 TIVE DEVICES
 HANDLING

BINDENDE ANGABEN UEBER VARIANTEN,
 TRIMMWERTE, BAUTEILWERTE UND
 NICHT BESTUECKTE BAUTEILE SIEHE SA.
 FOR BINDING INFORMATION ON MODELS,
 TRIMMING AND COMPONENTS VALUES AND
 NONFITTED COMPONENTS SEE PARTS LIST.

03/	48169	23.08.94	BU	1GPK	TAG	NAME	BENENNUNG
				BEARB.		BU	NETZTEIL POWER SUPPLY
				GEPR.			
				NDRN			
				PLOTT	24.08.94		
REND. IND.	RENDERUNGS- MITTEILUNG	DATUM	NAME	 ROHDE & SCHWARZ		ZEICHN.-NR.	
						11	
				ZU GERÄT	SMY	PEG. I. V.	1062

50

100

150

4

5

6

7

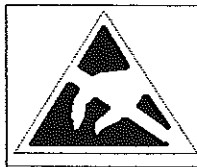
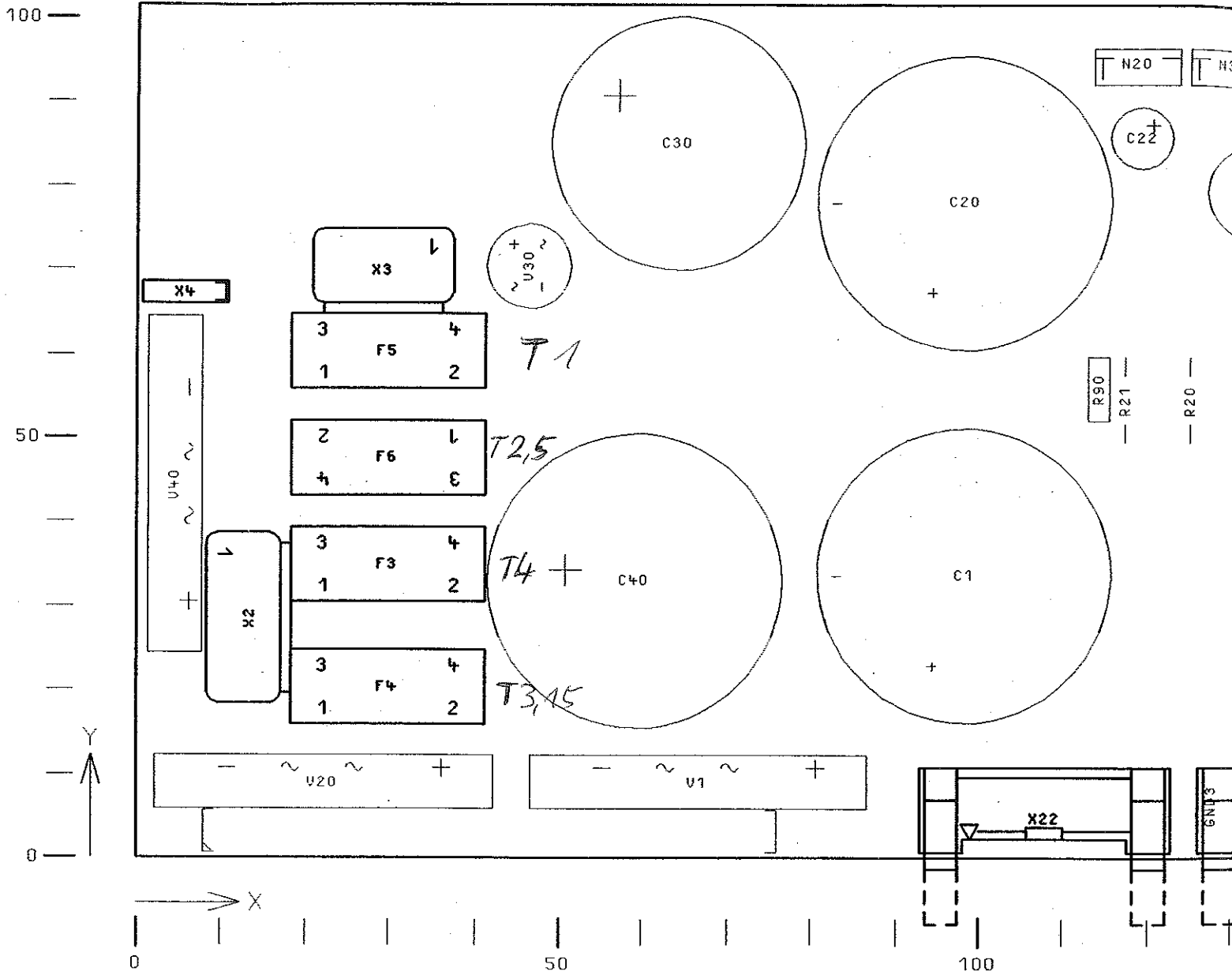

ACHTUNG: EGB!
 ELEKTROSTATISCH GEFÄHRDETE
 BAUELEMENTE ERFORDERN EINE
 BESONDERE HANDHABUNG.
ATTENTION ESD!
 ELECTROSTATIC SENSITIVE DEVICES
 REQUIRE A SPECIAL HANDLING

BINDENDE ANGABEN UEBER VARIANTEN,
 TRIMMWERTE, BAUTEILWERTE UND
 NICHT BESTUECKTE BAUTEILE SIEHE SA.

FOR BINDING INFORMATION ON MODELS,
 TRIMMING AND COMPONENTS VALUES AND
 NONFITTED COMPONENTS SEE PARTS LIST.

03/	48169	23.08.94	BU	16PP
				BERPB
				GEPR.
				NORM
				PLOTT
				R/S
				RO
REND. IND.	RENDERUNGS- MITTEILUNG	DATUM	NAMEN	ZU GERÄT

FUER DIESE ZEICHNUNG BEHALTEN WIR UNS ALLE RECHTE VOR
DIESE ZEICHNUNG IST KEIN RECHNERAUSDRUCK, AENDERUNGEN KOENNEN NUR DURCH AEND
DES DATENSATZES ERFOLGEN

F
E
D
C
B
A

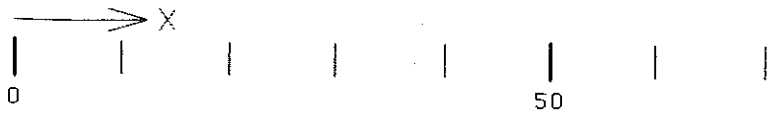
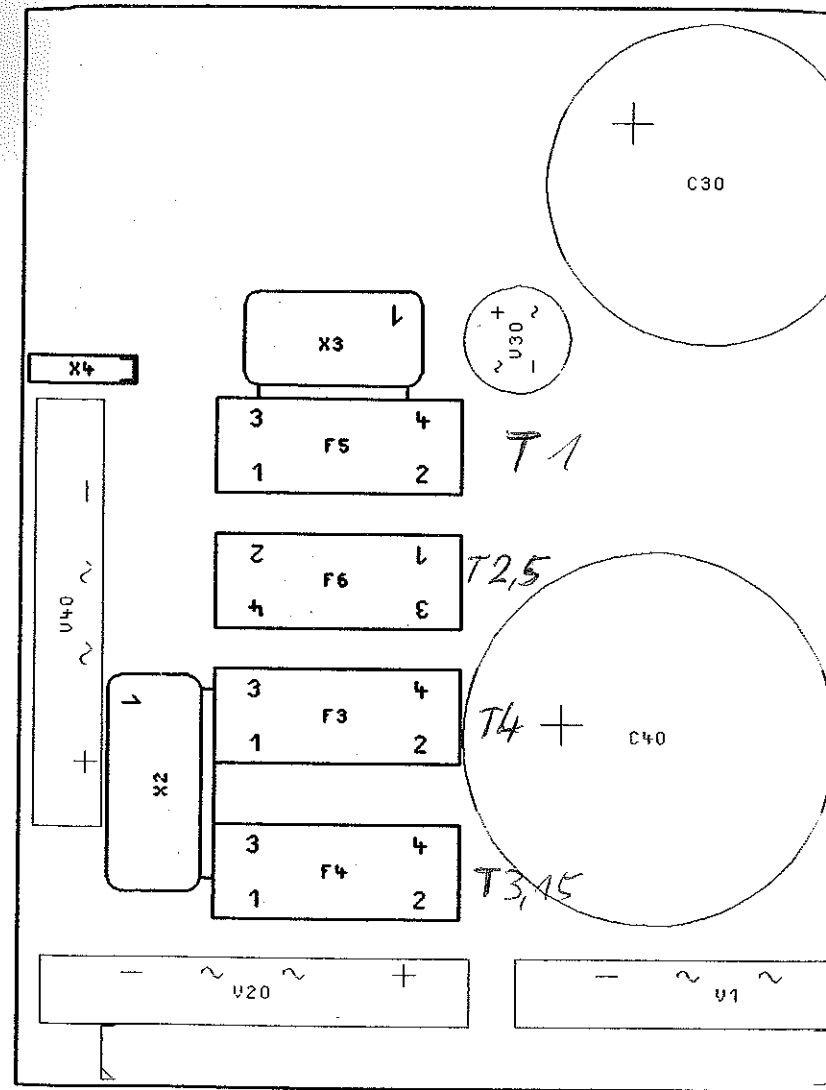
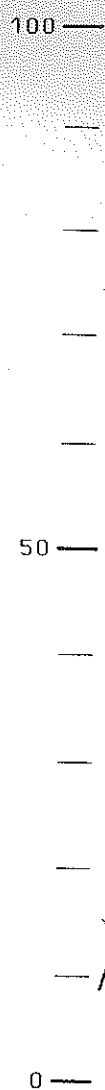

DARSTELLUNG SEITE B
VIEW ON SIDE B



ACHTUNG: EGB!
ELEKTROSTATISCH GEFAHRDETE
BAUELEMENTE EFFORDERN EINE
BESONDERE HANDHABUNG.
ATTENTION ESD!
ELECTROSTATIC SENSITIVE DEVICES
REQUIRE A SPECIAL HANDLING

BINDENDE ANGABEN UEBER VARIANTEN,
TRIMMWERTE, BAUTEILWERTE UND
NICHT BESTUECKTE BAUTEILE SIEHE SA
FOR BINDING INFORMATION ON MODELS,
TRIMMING AND COMPONENTS VALUES AND
NONFITTED COMPONENTS SEE PARTS LIS

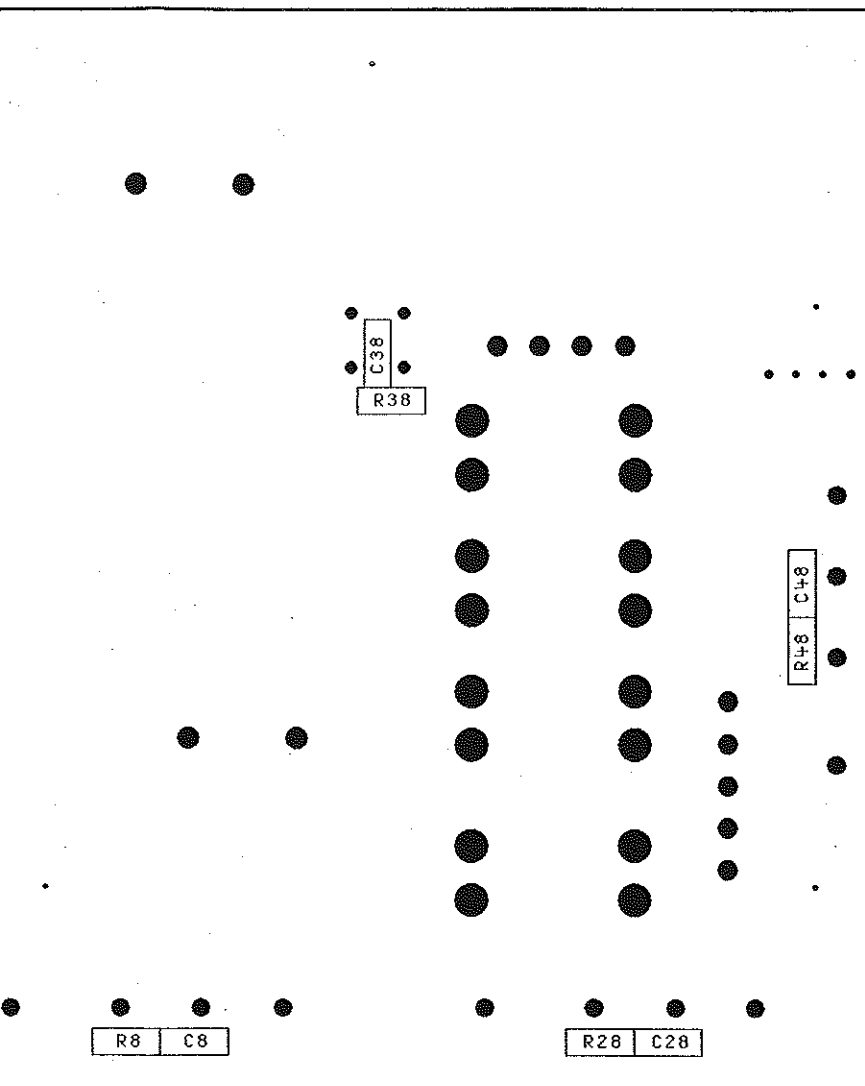

100

50

Y

0

X

50

0

03/	48169	23.08.94	BU	1GPK	TAG	NAME	BENENNUNG		Z
				BEARB.		BU	NETZTEILEINHEIT		
				GEPR.			POWER SUPPLY UNIT		
				NORN					
				PLOTT	24.08.94				
/				 ROHDE & SCHWARZ			ZEICHN.-NR.		BLATT-NR.
REND. IND.	ENDERUNGS-NITTEILUNG	DATUM	NAME				1062.5902.01		ED
				ZU GERÄT	SMY	REG. I. V.	1062.5502	ERSTE Z.	V. BL.

5 A

6

7

8

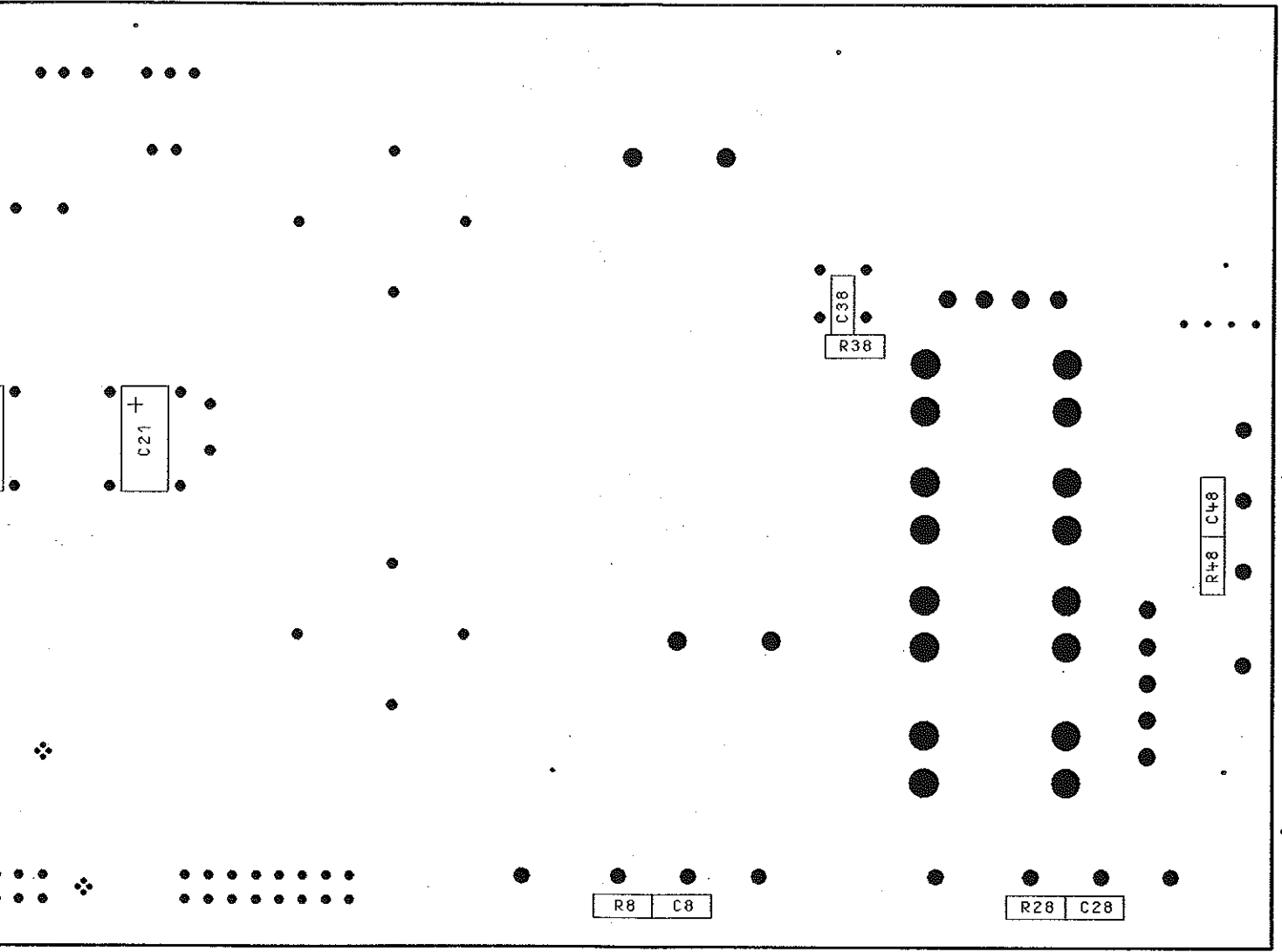

100

50

0

ESD!
SENSITIVE DEVICES
SPECIAL HANDLING

BINDENDE ANGABEN UEBER VARIANTEN,
TRIMMWERTE, BAUTEILWERTE UND
NICHT BESTUECKTE BAUTEILE SIEHE SA.
FOR BINDING INFORMATION ON MODELS,
TRIMMING AND COMPONENTS VALUES AND
NONFITTED COMPONENTS SEE PARTS LIST.

03/	48169	23.08.94	BU	1GPK	TAG	NAME	BENENNUNG
				BEARB.		BU	NETZ POWER
				GEPR.			
				NORN			
				PLOTT	24.08.94		
				 ROHDE & SCHWARZ			ZEICHN.-NR.
REND. IND.	RENDERUNGS- MITTEILUNG	DATUM	NAME				ZU GERNET
							10

4

5

6

7

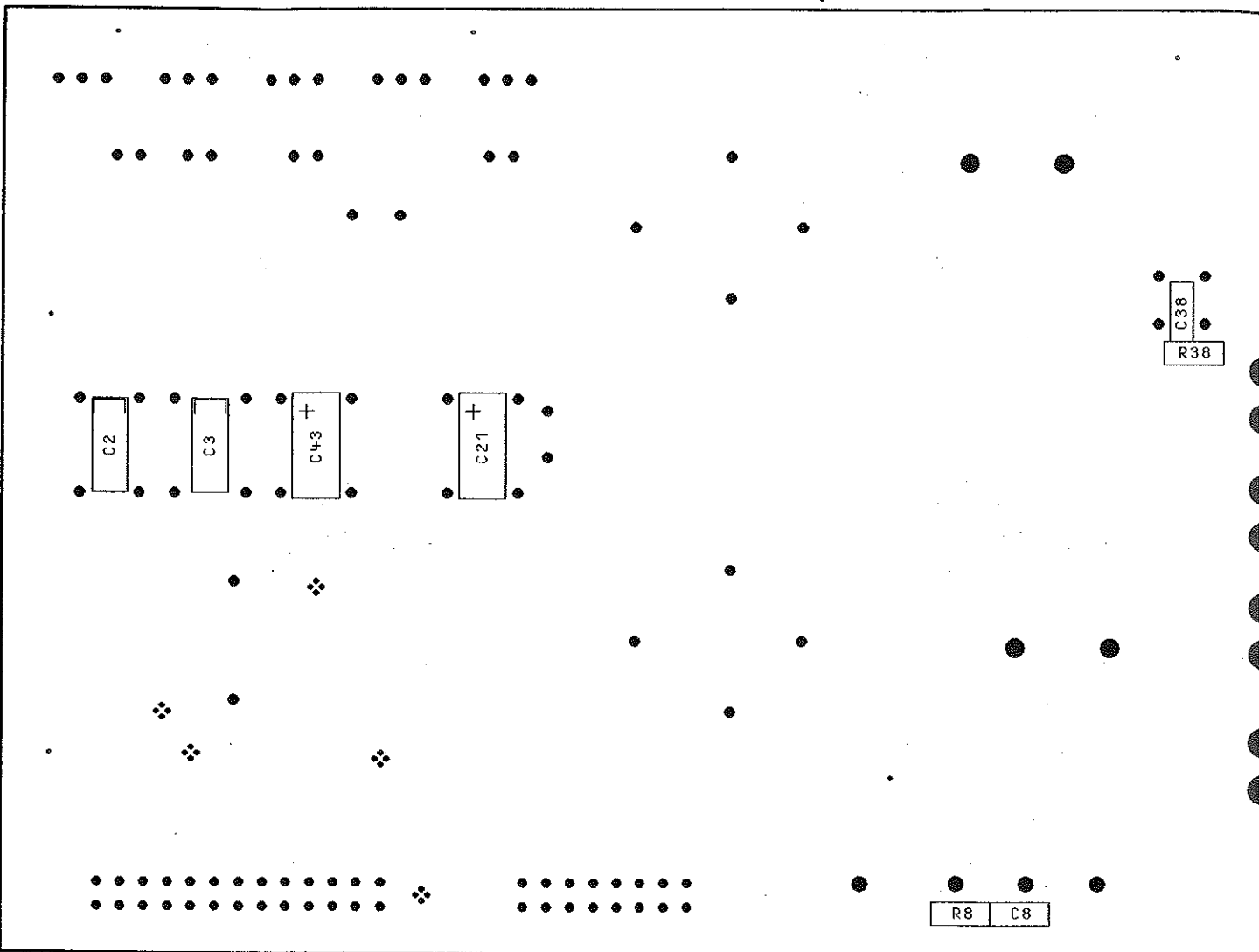

150

100

50

SEITE A
A



ACHTUNG: EGB!
ELEKTROSTATISCH GEFÄHRDETE
BAUELEMENTE ERFORDERN EINE
BESONDERE HANDHABUNG.
ATTENTION ESD!
ELECTROSTATIC SENSITIVE DEVICES
REQUIRE A SPECIAL HANDLING

BINDENDE ANGABEN UEBER VARIANTEN,
TRIMMWERTE, BAUTEILWERTE UND
NICHT BESTUECKTE BAUTEILE SIEHE SA.

FOR BINDING INFORMATION ON MODELS,
TRIMMING AND COMPONENTS VALUES AND
NONFITTED COMPONENTS SEE PARTS LIST.

03/	48169	23.08.94
REND. IND.	ÄNDERUNGS- MITTEILUNG	DATUM

2

3

4

5

DIESE ZEICHNUNG IST EINE RECHNERRUSSDRAUCK, RENDRERUNGEN KOENNEN NUR DURCH RENDRERUNGEN DES DATENSATZES ERFOLGEN

F
E
D
C
B
A

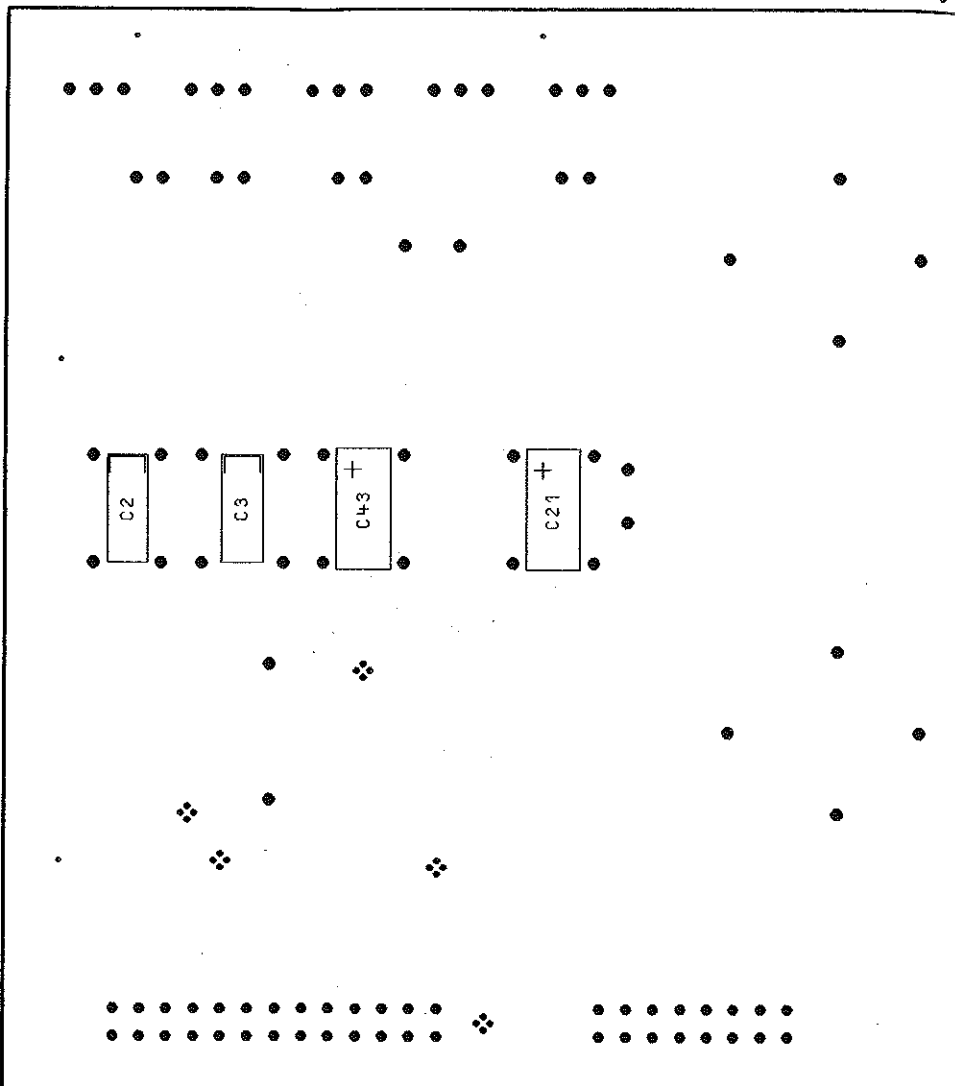

150

100

DARSTELLUNG SEITE A
VIEW ON SIDE A

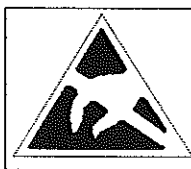

ACHTUNG: EGB!
ELEKTROSTATISCH GEFÄHRDETE
BAUELEMENTE ERFORDERN EINE
BESONDERE HANDHABUNG.
ATTENTION ESD!
ELECTROSTATIC SENSITIVE DEVICES
REQUIRE A SPECIAL HANDLING

BINDENDE ANGABEN UEBER VARIANTEN,
TRIMMWERTE, BAUTEILWERTE UND
NICHT BESTUECKTE BAUTEILE SIEHE S...

FOR BINDING INFORMATION ON MODELS
TRIMMING AND COMPONENTS VALUES AND
NONFITTED COMPONENTS SEE PARTS L...



ROHDE&SCHWARZ

SERVICEUNTERLAGEN

Referenzoszillator (Option)

1039.1027.02

Inhaltsverzeichnis

7.	Prüfen und Instandsetzung.....	5
7.1	Funktionsbeschreibung.....	5
7.2	Meßgeräte und Hilfsmittel.....	5
7.3	Fehlersuche.....	5
7.4	Prüfen und Abgleich.....	6
7.4.1	Stromaufnahme.....	6
7.4.2	Prüfen des Oszillators und des 10MHz- Verstärkers.....	6
7.4.3	Prüfen der Interrupterzeugung (OVEN COLD).....	6
7.4.3.1	Variante 02.....	6
7.4.3.2	Variante 04.....	6
7.4.4	Abgleich des Oszillators.....	7
7.4.4.1	Variante 02.....	7
7.4.4.2	Variante 04.....	7
7.5	Zerlegung und Zusammenbau.....	7
7.6	Externe Schnittstellen.....	8

Schaltteilliste
Koordinatenliste
Stromlauf
Bestückungsplan

7. Prüfen und Instandsetzung

7.1 Funktionsbeschreibung

Die Option Referenzoszillator OCXO ersetzt die interne 10MHz-Zeitbasis durch einen thermostatgeregelten hochwertigen Quarzoszillator, wodurch sich die Gerätedaten bezüglich Genauigkeit der Referenzfrequenz und Alterung wesentlich verbessern.

Die Baugruppe enthält neben dem eigentlichen Oszillator noch Bausteine zur Erzeugung der Versorgungsspannung von 12V aus der 15V Netzteilspannung, einen abschaltbaren Auskoppelverstärker und bei der Variante 04 noch eine Schaltung zur Erzeugung des 'OVEN-COLD'- Interrupts.

Der Rechner erkennt nach dem Einschalten selbstständig, ob die Option ROSC bestückt ist. Die Zeitbasis auf der Synthese wird daraufhin abgeschaltet.

Es existieren zwei verschiedene Varianten Optionsquarze. Die Variantenummer ist auf der Druckschaltung der Baugruppe ersichtlich. Die Variante 02 läßt eine elektrische Abstimmung der Sollfrequenz zu, während die Variante 04 einen mechanischen Abgleich mit einem Trimmer erfordert.

7.2 Meßgeräte und Hilfsmittel

1. DC-Voltmeter zB. UDS5, URE
2. HF-Spektrumanalysator bis 100MHz zB. FSA
3. Kalibrierter Frequenzzähler 10MHz (wie in FSA enthalten)
4. Oszilloskop mit ca. 100MHz Bandbreite

7.3 Fehlersuche

Frequenzfehler	Abstimmspannung bis zum Oszillator verfolgen. Abweichungen durch Alterung neu kalibrieren
Pegelfehler	Steuersignal REFOFF verfolgen Auskoppelstufe prüfen Ausgangspegel des Oszillators prüfen

7.4 Prüfen und Abgleich

7.4.1 Stromaufnahme

- Gerät kalt mit Netzschalter einschalten.
- ▶ Die Stromaufnahme auf +15V soll während der Aufheizphase ca. 270mA nicht überschreiten und nach ca. vier Minuten auf maximal 135mA sinken.
Die Stromaufnahme auf +5V beträgt maximal 2mA, auf -15V 7mA.

7.4.2 Prüfen des Oszillators und des 10MHz-Verstärkers

- SMY einschalten.
- ▶ Das Steuerbit REFOFF muß auf 'low' liegen. Der DC-Arbeitspunkt der Auskoppelstufe soll bei $5 \pm 2V$ liegen.
- Mit hochohmigem Tastkopf und Oszilloskop am Ausgang des Oszillators messen.
- ▶ Der Oszillator muß TTL-Pegel liefern.
- Spektrumanalysator an der Ausgangsbuchse X711 der Option anschließen.
- ▶ Das 10MHz-Signal muß eine Amplitude von $7.5dBm \pm 1.5dB$ aufweisen.
- Am Display auf externe Referenz schalten (RF EXT/AC).
- ▶ Das Steuerbit REFOFF muß auf 'high' gehen, der Ausgangspegel des Referenzsignals an X711 auf unter $-50dBm$ sinken.

7.4.3 Prüfen der Interrupterzeugung (OVEN COLD)

Solange der Thermostat des Quarzoszillators die Solltemperatur nicht erreicht hat, liegt der Ausgang OVENCOLD (X22.13) auf 'high'. Dies wird vom Rechner erkannt und führt zu der Meldung 'OVEN COLD' am Display.

7.4.3.1 Variante 02

- Brücke 40 auf X40.1/2 und Brücke 50 auf X50.1/2 stecken.
- ▶ Ein warmgelaufener Oszillator (ca. 5min) darf keinen OVEN COLD Interrupt liefern (= 'high') und damit auch keine Meldung am Display.
Ein warmgelaufener Oszillator muß nach 30 Sekunden abschalten wieder einen Interrupt anzeigen (= 'low').

7.4.3.2 Variante 04

- Steckbrücke X40 ziehen und an X40.2 eine Gleichspannung von 0 bis 12V einspeisen.
- ▶ Bei einer Gleichspannung von unter $5.6 \pm 1V$ und über $6.4 \pm 1V$ muß eine OVEN-COLD-Meldung erfolgen, dazwischen darf kein Interrupt gemeldet werden.

- Spannungsmesser an X40.3 anschließen.
- ▶ Nach etwa 5min Betriebsdauer muß die Spannung an X40.3 mit $6.0 \pm 0.2V$ gemessen werden.

7.4.4 Abgleich des Oszillators

- Kalibrierten Frequenzzähler an X711 anschließen und die Ausgangsfrequenz messen.

7.4.4.1 Variante 02

- Am Gerät mit Spezialfunktion ⁵¹~~48~~ die Kalibrierung des Referenzoszillators aufrufen, den Wert 2048 eingeben und mit 'Enter' abschließen.
- ▶ Nach zwei Stunden Betrieb mit dem Drehrad die Frequenz auf 10MHz einstellen.
Die Spannung an X22.16 muß dabei zwischen 2 und 4V liegen. Das entspricht einem Eingabewert von etwa 820 bis 1640.

7.4.4.2 Variante 04

- Den Oszillator mindestens zwei Stunden einlaufen lassen
- Ist die Frequenzabweichung nach dieser Zeit größer $5 \cdot 10^{-8}$, so muß die Sollfrequenz neu abgeglichen werden.
- ▶ Der Abgleich auf 10MHz erfolgt mit einem Trimmer seitlich am Oszillatorgehäuse.

7.5 Zerlegung und Zusammenbau

- Beplankung des Geräts abnehmen (siehe Serviceanleitung Gesamtgerät 6.5).
- Flachbandkabel von der Buchse am Netzteil lösen.
- HF-Kabel von der Buchse X711 auf der Baugruppe abziehen.

Die Baugruppe ist mit vier Schrauben seitlich am Rahmen des Geräts fixiert. Diese sind von der Außenseite zugänglich.

- Halterungsschrauben lösen und die Baugruppe nach oben herausnehmen.

Der Einbau erfolgt sinngemäß in umgekehrter Reihenfolge.

7.6

Externe Schnittstellen

Pin	Name	Ein/Ausgang	Herkunft/Ziel	Wertbereich	Signalbeschreibung
X22.1	VA5-P	Eingang	Netzteil X22.1	+4.9 .. +5.3V	Imax=2mA, Versorgung
X22.2	VA15-P	"	" X22.2	+14.4 . +15.6V	Imax=250mA, Versorgung
X22.3	frei				
X22.4	REFOFF	Eingang	Rechner X3.21	TTL-HCT	Referenz ausschalten
X22.5	OPTERKREF	Ausgang	Rechner X3.25	TTL-HCT	Erkennung RO5C
X22.6	VA15-H	Eingang	Netzteil X22.6	-15.6 . -14.4V	Imax=7mA, Versorgung
X22.7	frei				
X22.8	GND				
X22.9	frei				
X22.10	GND				
X22.11	frei				
X22.12	frei				
X22.13	OVENCOLD	Ausgang	Rechner X3.26	TTL-HCT	Interrupt OVEN COLD
X22.14	GND				
X22.15	GND				
X22.16	OPTUNE	Eingang	Synthese X1A.10	0 ... 10V	Abstimmspannung
X711	REF	Ausgang	Synthese X128	7.5dBm	Referenzsignal



ROHDE & SCHWARZ

SERVICE INSTRUCTIONS

Reference Oscillator (Option)

1039.1027.02

Contentss

7.	Testing and Repair.....	5
7.1	Function Description.....	5
7.2	Test Instruments and Utilities.....	5
7.3	Troubleshooting.....	5
7.4	Testing and Adjustment.....	6
7.4.1	Power Consumption.....	6
7.4.2	Testing the Oscillator and the 10-MHz Amplifier.....	6
7.4.3	Testing the Generation of Interrupts (OVEN COLD).....	6
7.4.3.1	Model 02.....	6
7.4.3.2	Model 04.....	6
7.4.4	Adjusting the Oscillator.....	7
7.4.4.1	Model 02.....	7
7.4.4.2	Model 04.....	7
7.5	Disassembly and Assembly.....	7
7.6	External Interfaces.....	8

Parts list
List of coordinates
Circuit diagram
Component layout diagram

7. Testing and Repair

7.1 Function Description

The reference-oscillator option OCXO replaces the internal 10-MHz time base by a thermostat-controlled top-quality crystal oscillator thus considerably improving the instrument data on the accuracy of the reference frequency and ageing.

Apart from the oscillator, the module contains components for generation of the 12-V supply voltage from the 15 V of the power supply, a decoupling amplifier which can be switched off, and the model 04 additionally provides a circuit for generation of the 'OVEN COLD' interrupt.

Upon switch-on, the controller checks whether the ROSC option is fitted. If it is, the time base on the synthesis is switched off.

Two different models of crystal are provided. The number of the model can be looked up on the PCB. Model 02 allows for electrical tuning of the rated frequency, whereas model 04 requires mechanical trimming.

7.2 Test Instruments and Utilities

1. DC voltmeter, e.g., UDS5, URE
2. RF spectrum analyzer up to 100 MHz, e.g., FSA
3. Calibrated 10-MHz frequency counter (contained in FSA)
4. Oscilloscope with approx. 100-MHz bandwidth

7.3 Troubleshooting

Frequency error	Trace tuning voltage to the oscillator Re-calibrate deviations due to ageing
Level error	Trace control signal REFOFF Check decoupling stage Check output level of the oscillator

7.4 Testing and Adjustment

7.4.1 Power Consumption

- Cold-start the instrument using the power switch.
- ▶ The power consumption to +15V during the warm-up phase should not exceed approx. 270mA and should drop to max. 135 mA after approx. four minutes.
The power consumption up to +5V is max. 2 mA, to -15V it is 7mA.

7.4.2 Testing the Oscillator and the 10-MHz Amplifier

- Switch on SMY.
- ▶ The control bit REFOFF must assume 'low' state. The dc operating point of the decoupling stage should be at $5 \pm 2V$.
- Measure at the oscillator output using a high-impedance probe and an oscilloscope.
- ▶ The oscillator must supply TTL level.
- Connect spectrum analyzer to the output socket X711 of the option.
- ▶ The 10-MHz signal must have an amplitude of $7.5dBm \pm 1.5dB$.
- Switch to external reference (RF EXT/AC) on the display.
- ▶ The control bit REFOFF must assume 'high' state, the output level of the reference signal at X711 must drop below -50dBm.

7.4.3 Testing the Generation of Interrupts (OVEN COLD)

As long as the thermostat of the crystal oscillator has not yet reached the rated temperature, the OVENCOLD output (X22.13) assumes 'high' state. The processor initiates output of the message 'OVEN COLD' on the display.

7.4.3.1 Model 02

- Plug on jumper 40 to X40.1/2 and jumper 50 to X50.1/2.
- ▶ After warming up (approx. 5 min.), an oscillator must not initiate an OVEN COLD interrupt (= 'high') and any message on the display.
30 seconds after switch off, it must indicate an interrupt again (= 'low').

7.4.3.2 Model 04

- Unplug jumper X40 and apply a dc voltage between 0 and 12 V to X40.2.
- ▶ An OVEN-COLD message is output, if the dc voltage is below $5.6 \pm .1V$ or above $6.4 \pm .1V$, it must not be output, if the voltage is in between.

- Connect voltmeter to X40.3.
- ▶ After 5 min. of operation, the voltage measured at X40.3 must be $6.0 \pm 0.2V$.

7.4.4 Adjustment of the Oscillator

- Connect calibrated frequency counter to X711 and measure the output frequency.

7.4.4.1 Model 02

- Call calibration of the reference oscillator on the instrument via special function ⁴⁸₅₇, enter the value 2048 and terminate with 'Enter'.
- ▶ After two hours of operation, set the frequency to 10 MHz using the spinwheel.
The voltage at X22.16 must be between 2 and 4V, which corresponds to an input value of approx. 820 to 1640.

7.4.4.2 Model 04

- The oscillator requires a warm-up period of at least two hours.

If the frequency deviation exceeds $5 \cdot 10^{-8}$ after this period, the rated frequency must be re-adjusted.

- ▶ The oscillator is adjusted to 10 MHz using a trimmer at the side of the oscillator housing.

7.5 Disassembly and Assembly

- Remove instrument panelling (see service instructions for the overall instrument, Section 6.5).
- Disconnect ribbon cable from the socket on the power supply.
- Disconnect RF cable from the socket X711 on the module.

The module is fixed to the lateral frame of the instrument using four screws which are accessible from outside.

- Unscrew support screws and remove the module to the top.

The module is installed correspondingly in the reverse order.

7.6

External Interfaces

Pin	Name	Input/Output	Origin/Destination	Specified range	Signal description
X22.1	VA5-P	Input	Power supply X22.1	+4.9 to +5.3V	I _{max} =2mA, supply
X22.2	VA15-P	"	" X22.2	+14.4 to +15.6V	I _{max} =250mA, supply
X22.3	not used				
X22.4	REFOFF	Input	Controller X3.21	TTL-HCT	Switch off reference
X22.5	OPTERKREF	Output	Controller X3.25	TTL-HCT	Identification of ROSC
X22.6	VA15-N	Input	Power supply X22.6	-15.6 to -14.4V	I _{max} =7mA, supply
X22.7	not used				
X22.8	GND				
X22.9	not used				
X22.10	GND				
X22.11	not used				
X22.12	not used				
X22.13	OVENCOLD	Output	Controller X3.26	TTL-HCT	Interrupt OVEN COLD
X22.14	GND				
X22.15	GND				
X22.16	OPTUNE	Input	Synthesis X1A.10	0 to 10V	Tuning voltage
X711	REF	Output	Synthesis X12B	7.5dBm	Reference signal



ROHDE & SCHWARZ

Schaltteillisten
numerisch geordnet

Part lists
in numerical order

Listes des pièces détachées
par numéros de référence

Für diese Unterlage behalten wir uns alle Rechte vor.

Kennz. Comp. No.	Benennung Designation	Sachnummer Stock No.	Hersteller Manufacturer	Bezeichnung Designation	enthalten in contained in
B40	ED 10MHZ-QU.OSZ.OCXO 12V 10MHZ CRYSTAL OSCILLATOR NUR VAR/ONLY MOD: 04	0803.8980.00	QUARZKERAM	2100T-S151 (H)	
B50	ED 10MHZ-QU.OSZ.OCXO CRYSTAL OSCILLATOR NUR VAR/ONLY MOD: 02	1039.1410.00	KVG	OCXO-S15	
C1	CE 100UF+-20%25V RM2.5 ELECTROLYTIC CAPACITOR	CE 0008.7891.00	PANASONIC	ECA-1EFG101I	
C2	CE 220UF+-20%10V RM2,5 ELECTROLYTIC CAPACITOR	CE 0008.7927.00	PANASONIC	ECA-1AFG221I	
C3	CE 1UF +-10% 25V EIA3528 TANTALUM SMD-CAPACITOR	CE 0007.7217.00	SPRAGUE	293D 105 X9 025 B2T	
C4	CE 100UF+-20%25V RM2.5 ELECTROLYTIC CAPACITOR	CE 0008.7891.00	PANASONIC	ECA-1EFG101I	
C11	CC 100NF+-10%50V X7R 1206 CERAMIC CHIP CAPACITOR	CC 0007.5237.00	PHILIPS_CO	2238 581 15649	
C40	CE 100UF+-20%25V RM2.5 ELECTROLYTIC CAPACITOR	CE 0008.7891.00	PANASONIC	ECA-1EFG101I	
C50	CC 100NF+-10%50V X7R 1206 CERAMIC CHIP CAPACITOR NUR VAR/ONLY MOD: 04	CC 0007.5237.00	PHILIPS_CO	2238 581 15649	
C66	CC 100NF+-10%50V X7R 1206 CERAMIC CHIP CAPACITOR	CC 0007.5237.00	PHILIPS_CO	2238 581 15649	
C70	CC 220PF+-1%50V NPO 1206 CERAMIC CHIP CAPACITOR	CC 0099.8850.00	PHILIPS_CO	2238 863 18221	
C71	CC 1NF+-1% 50V NPO 1206 SMD CERAMIC CAPACITOR	CC 0007.7398.00	PHILIPS_CO	2222 863 *8102	
C72	CC 100NF+-10%50V X7R 1206 CERAMIC CHIP CAPACITOR	CC 0007.5237.00	PHILIPS_CO	2238 581 15649	
C73	CC 39PF+-1%50V NPO 1206 CERAMIC CHIP CAPACITOR	CC 0099.8796.00	MURATA	GRM42-6COG 390F 50PT	
C76	CC 180PF+-1%50V NPO 1206 CHIP CAPACITOR	CC 0099.8844.00	PHILIPS_CO	2238 863 18181	
C79	CC 100NF+-10%50V X7R 1206 CERAMIC CHIP CAPACITOR	CC 0007.5237.00	PHILIPS_CO	2238 581 15649	
L1	LD 15UH 10% 1R2 0,46A CHOKE	LD 0026.4149.00	DALE	IM 6	
L2	LD 22UH 10% 0,14A 1210 SMD-INDUCTOR	LD 0520.7886.00	SIEMENS	B82422-A1223-K100	
L40	LD 3,30UH10%,850HMO,285A CHOKE	LD 0067.2928.00	DALE	IM2	
L70	LD 100UH 10% 0,06A 1210 SMD-INDUCTOR	LD 0007.9261.00	SIEMENS	B82422-A1104-K100	
L71	LD 4,7UH 10% 0,15A 1210 SMD-INDUCTOR	LD 0008.1687.00	SIEMENS	B82422-A1472-K100	
L72	LD 2,2UH 10% 0,27A 1210 SMD-INDUCTOR	LD 0520.7870.00	SIEMENS	B82422-A1222-K100	
N1	BO LM7812CT+12V1AO VREGL VOLTAGE REGULATOR	BO 0344.9641.00	NSC	LM340T12	
N50	BO TLO72ACD 2XFET OPAMP OPERATIONAL AMPLIFIER NUR VAR/ONLY MOD: 04	0803.1057.00	TEXAS	TL 072 ACDR	
N60	BO LM2903D 2XLP COMPAR DUAL NUR VAR/ONLY MOD: 04	0520.7734.00	SIGNETICS	LM2903(D)	
R1	RG 1,0 KO +-1%TK100 1206 CHIP RESISTOR	RG 0006.7271.00	ROEDERSTEI	DC2 1,0KOHM 1%TK100	
R19	RG 475 KOHM+-1%TK100 1206 RESISTOR CHIP NUR VAR/ONLY MOD: 04	RG 0007.6079.00	ROEDERSTEI	DC2 475KOHM 1%TK100	
R21	RG 4,75KOHM+-1%TK100 1206 RESISTOR CHIP	RG 0007.5820.00	ROEDERSTEI	DC2 4,75KOHM 1%TK100	
R29	RG 475 OHM+-1%TK100 1206 RESISTOR CHIP	RG 0007.5695.00	ROEDERSTEI	DC2 475OHM 1%TK100	
R40	RG 0-OHM WIDERSTAND-CHIP RESISTOR CHIP 0-OHM NUR VAR/ONLY MOD: 02	RG 0007.5108.00	DRALORIC	CR 1206	
R45	RG 0-OHM WIDERSTAND-CHIP RESISTOR CHIP 0-OHM NUR VAR/ONLY MOD: 04	RG 0007.5108.00	DRALORIC	CR 1206	
R50	RG 4,75KOHM+-1%TK100 1206 RESISTOR CHIP NUR VAR/ONLY MOD: 04	RG 0007.5820.00	ROEDERSTEI	DC2 4,75KOHM 1%TK100	

1GPK

413 3PUA

Äi

Datum
Date

Schaltteilliste für
Parts list for

Sachnummer
Stock No.

Blatt-Nr.
Page



ROHDE & SCHWARZ

08

16.09.97

ED REFERENZOSZ.-OCXO

REFERENCE.-OSC.-OCXO

1039.1027.01 SA

1+

095.0028-0693

Kennz. Comp. No.	Benennung Designation	Sachnummer Stock No.	Hersteller Manufacturer	Bezeichnung Designation	enthalten in contained in
R51	RG 4,75KOHM+-1%TK100 1206 RESISTOR CHIP NUR VAR/ONLY MOD: 04	RG 0007.5820.00	ROEDERSTEI	DC2 4,75KOHM 1%TK100	
R53	RG 0-OHM WIDERSTAND-CHIP RESISTOR CHIP 0-OHM NUR VAR/ONLY MOD: 02	RG 0007.5108.00	DRALORIC	CR 1206	
R54	RG 0-OHM WIDERSTAND-CHIP RESISTOR CHIP 0-OHM NUR VAR/ONLY MOD: 04	RG 0007.5108.00	DRALORIC	CR 1206	
R56	RG 15,0KOHM+-1%TK100 1206 RESISTOR CHIP NUR VAR/ONLY MOD: 04	RG 0007.5843.00	ROEDERSTEI	DC2 15,0KOHM 1%TK100	
R57	RG 2,21KOHM+-1%TK100 1206 RESISTOR CHIP NUR VAR/ONLY MOD: 04	RG 0007.5743.00	ROEDERSTEI	DC2 2,21KOHM 1%TK100	
R58	RG 15,0KOHM+-1%TK100 1206 RESISTOR CHIP NUR VAR/ONLY MOD: 04	RG 0007.5843.00	ROEDERSTEI	DC2 15,0KOHM 1%TK100	
R59	RG 4,75KOHM+-1%TK100 1206 RESISTOR CHIP NUR VAR/ONLY MOD: 04	RG 0007.5820.00	ROEDERSTEI	DC2 4,75KOHM 1%TK100	
R70	RG 1,0 KO +-1%TK100 1206 CHIP RESISTOR	RG 0006.7271.00	ROEDERSTEI	DC2 1,0KOHM 1%TK100	
R71	RG 4,75KOHM+-1%TK100 1206 RESISTOR CHIP	RG 0007.5820.00	ROEDERSTEI	DC2 4,75KOHM 1%TK100	
R72	RG 15,0KOHM+-1%TK100 1206 RESISTOR CHIP	RG 0007.5843.00	ROEDERSTEI	DC2 15,0KOHM 1%TK100	
R73	RG 150 OHM+-1%TK100 1206 RESISTOR CHIP	RG 0007.5589.00	ROEDERSTEI	DC2 150OHM 1%TK100	
R75	RG 562 OHM+-1%TK100 1206 CHIP RESISTOR	RG 0006.9068.00	ROEDERSTEI	DC2 562OHM 1%TK100	
R79	RG 1,0 KO +-1%TK100 1206 CHIP RESISTOR	RG 0006.7271.00	ROEDERSTEI	DC2 1,0KOHM 1%TK100	
V70	AK BFS17 N 30V 50MA TRANSISTOR	AK 0010.6460.00	VALVO	BFS17	
V71	AK BFS17 N 30V 50MA TRANSISTOR	AK 0010.6460.00	VALVO	BFS17	
W710	DY KABEL A7/X22	1062.7557.00			
X711	FJ EINBAUSTECKER F.GS SMB PLUG	FJ 0063.5168.00	ROSENBERGE	59S106-400-D3	

Für diese Unterlage behalten wir uns alle Rechte vor.

1GPK	413 3PUA	Äl	Datum Date	Schalttaelliste für Parts list for	Sachnummer Stock No.	Blatt-Nr. Page
	08	16.09.97	ED REFERENZOSZ. -DCXO REFERENCE. -OSC. -DCXO	1039.1027.01 SA	2-	

095.0028-0693

XY-Liste

XY List

Erklärung der Spaltenbezeichnungen:

- Part:** Bauelement-Kennzeichen.
- Side:** Leiterplatten-Seite, auf der sich das Bauelement befindet.
- XY:** Koordinaten (Millimeter) des Bauelementes auf der Leiterplatte bezogen auf den Nullpunkt.
- SQR, PG:** Planquadrat und Seite des Schaltbildes für das jeweilige Bauelement.

Explanation of column designations:

- Part:** Identification of instrument part.
- Side:** Side of the PC board on which instrument part is positioned.
- XY:** Coordinates (millimeter) of the component on the PC board in reference to zero point.
- SQR, PG:** Square and page of the diagram for the respective instrument part.

Service-Relevante Bauteile / Service-Relevant Components																	
Part	Side	X	Y	Sqr	Pg	Part	Side	X	Y	Sqr	Pg	Part	Side	X	Y	Sqr	Pg
B40	B	56	47	7F	1	N1	B	20	43	4E	1	N60-C				4B	1
B50	B	84	50	7E	1	N50-A	A	25	27	5B	1	V70	A	78	26	9D	1
C1	B	21	22	3E	1	N50-B				8C	1	V71	A	73	31	9E	1
C2	B	18	30	3E	1	N50-C				4B	1	W710	B	7	25	2E	1
C3	A	23	34	3F	1	N60-A	A	19	46	9B	1	X711	B	65	58	11E	1
C4	B	25	37	4E	1	N60-B				9B	1						

Nicht-Service-Relevante Bauteile / Non-Service-Relevant Components																	
Part	Side	X	Y	Sqr	Pg	Part	Side	X	Y	Sqr	Pg	Part	Side	X	Y	Sqr	Pg
C11	A	40	37	6F	1	L40	B	42	56	5E	1	R53	A	18	12	11C	1
C40	B	55	58	6E	1	L70	A	53	41	9F	1	R54	A	11	48	11C	1
C50	A	33	41	9C	1	L71	A	78	43	10E	1	R56	A	29	46	9C	1
C66	A	25	21	7C	1	L72	A	74	55	10E	1	R57	A	33	49	9B	1
C70	A	70	27	9E	1	R1	A	11	30	2E	1	R58	A	29	52	9B	1
C71	A	69	39	10E	1	R19	A	77	17	7E	1	R59	A	11	46	10C	1
C72	A	60	42	9E	1	R21	A	29	39	5F	1	R70	A	62	22	8E	1
C73	A	72	39	10E	1	R29	A	11	34	2F	1	R71	A	73	15	8D	1
C76	A	74	58	10E	1	R40	A	63	8	7D	1	R72	A	77	36	9E	1
C79	A	41	17	6D	1	R45	A	63	17	7D	1	R73	A	73	27	9D	1
L1	B	22	16	2E	1	R50	A	31	34	8C	1	R75	A	63	41	9E	1
L2	A	15	24	2E	1	R51	A	28	23	8B	1	R79	A	11	20	5D	1

ROHDE & SCHWARZ	-I	Datum Date	XY-Liste für XY-list for	Sach-Nummer Stock-Nr	Blatt Page
	03	21.11.94	ED REFERENZOSZ.-OCXO REFERENCE.-OSC.-OCXO	1039.1027.01 XY	1-

Stromläufe
Bestückungspläne
Circuit diagrams
Components plans
Schémas de circuit
Plans des composants

1 | 2 | 3 | 4

F | F

E | REF OFF

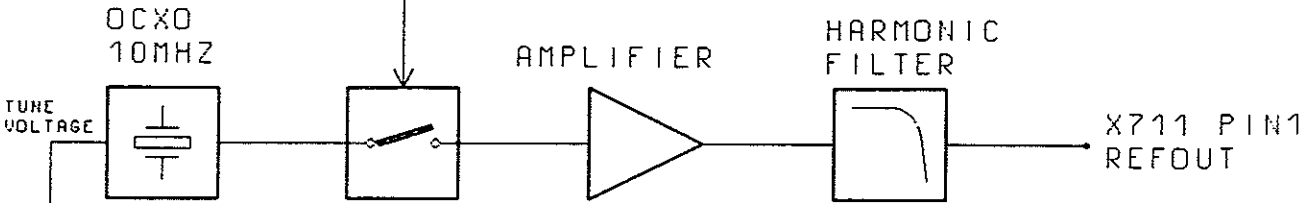

D | D

FUER DIESE UNTERLAGE
BEHALTEN WIR UNS ALLE RECHTE VOR

C | OVENCOLD

COMPERATOR

B | B



ACHTUNG: EGB!
 ELEKTROSTATISCH GEFÄHRDETE
 BAUELEMENTE ERFORDERN EINE
 BESONDERE HANDHABUNG.
ATTENTION ESD!
 ELECTROSTATIC SENSITIVE DEVICES
 REQUIRE A SPECIAL HANDLING

STROMLAUF GILT FUER VAR.02
 CIRCUIT DIAGRAM IS VALID FOR MOD.02

02/	49167 02	11.04.95	HM	1GPK	TAG	NAME	BENENNUNG
				BEARB.		HM	REFERENZOSZ. -OCXO REFERENCE -OSC. -OCXO
				GEPR.			
				MDRN			
				PLOTT	11.04.95		
/						ZEICHN.-NR.	BLATT-NR.
REND. IND.	RENDERUNGS- MITTEILUNG	DATUM	NAME	ROHDE&SCHWARZ		1039.1027.015	14
				ZU GERÄT	SMY-B1	PEG. I.V.	V. BL.
						1039.0995	EPSTE 2.

1 | 2 | 3 | 4

ZEICHN.-NR.

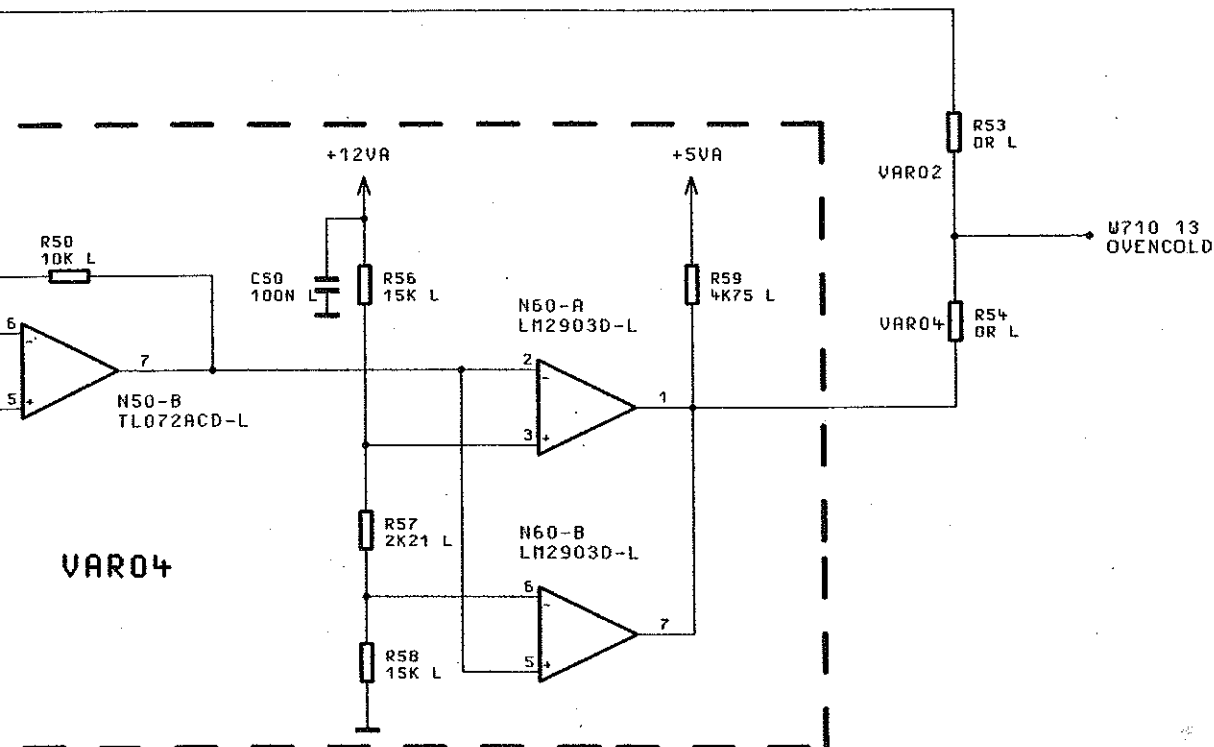
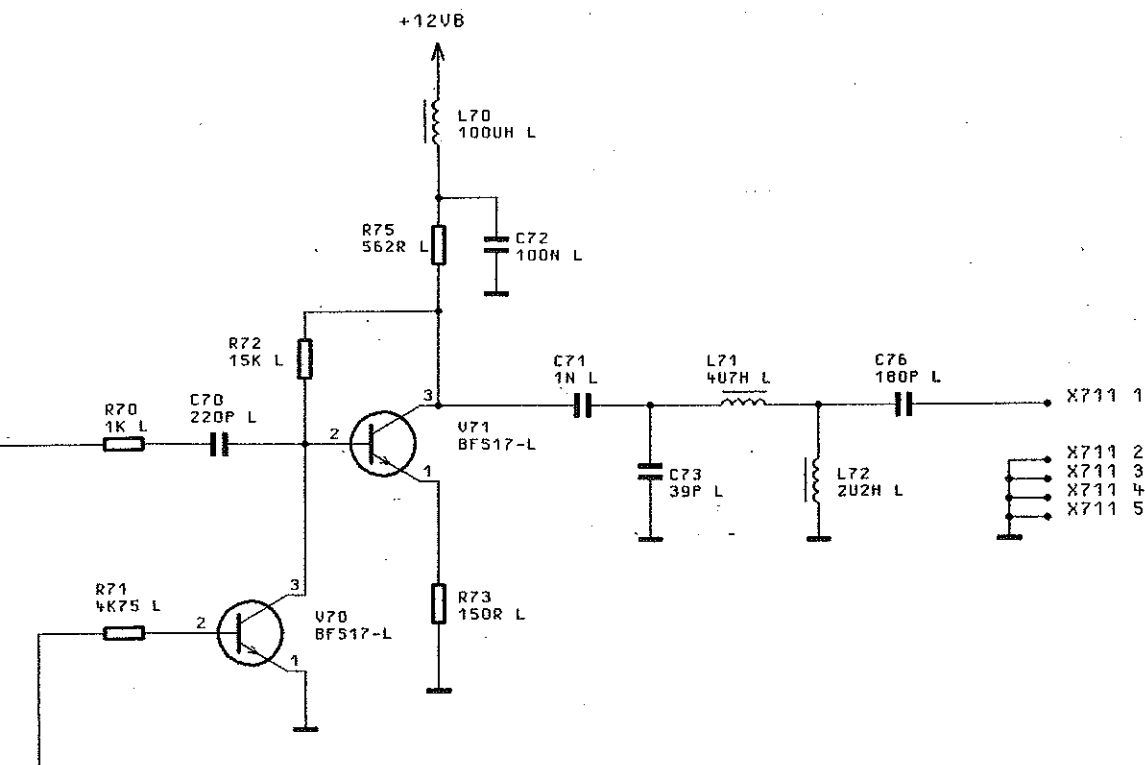

02/	49167 02	11.04.95	HM	16PK	TAG	NAME	BENENNUNG
				BEARB.		HM	REFERENZOSZ. -OCXO REFERENCE. -OSC. -OCXO
				GEPR.			
				NORM.			
				PLOTT	11.04.95		
				 ROHDE & SCHWARZ		ZEICHN.-NR.	1039.1027.015
REND. IND.	RENDERUNGS-NITTEILUNG	DATUM	NAME			ZU GERÄT	
						ERSTE Z.	
							BLATT-NR. 2+
							V. BL.

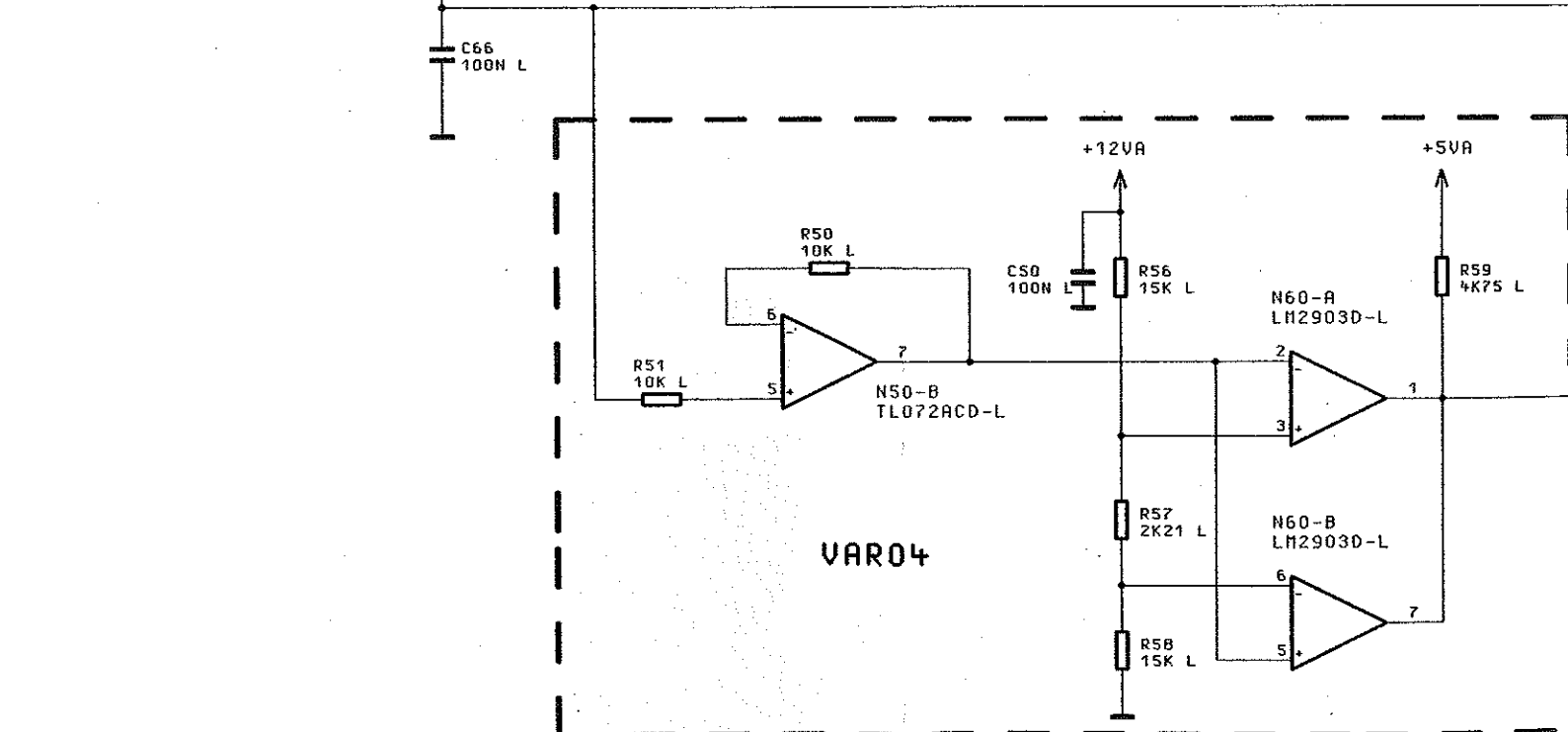
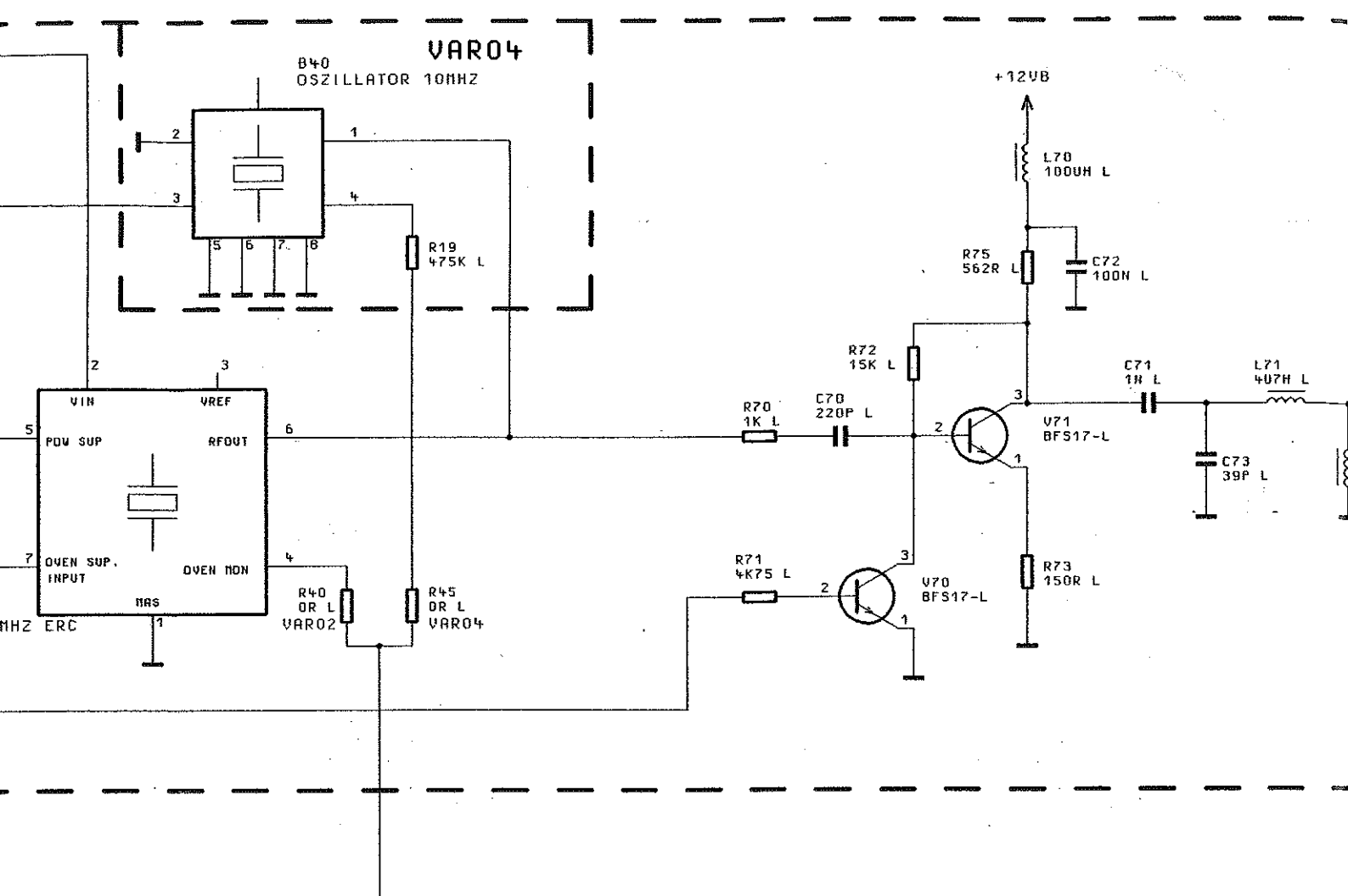

ACHTUNG: EGB!
 ELEKTROSTATISCH GEFÄHRDETE
 BAUELEMENTE ERFORDBN EINE
 BESONDERE HANDHABUNG.
ATTENTION ESD!
 ELECTROSTATIC SENSITIVE DEVICES
 REQUIRE A SPECIAL HANDLING

BZ/	49167 02	11.04.95	HM	1GPK	TAG	NAME
				BEARB.		HM
				GEPR.		
				NORN.		
				PLOTT	11.04.95	
REND. IND.	RENDERUNGS- MITTEILUNG	DATUM	NAME	 ROHDE & SCHWARZ ZU GERÄT SMY-B1		

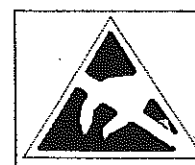
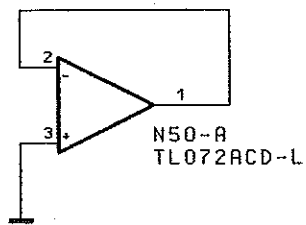
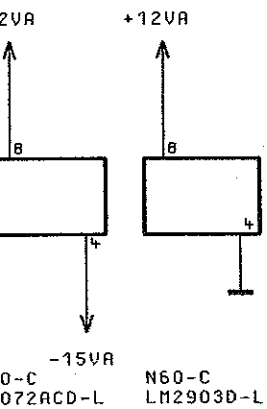
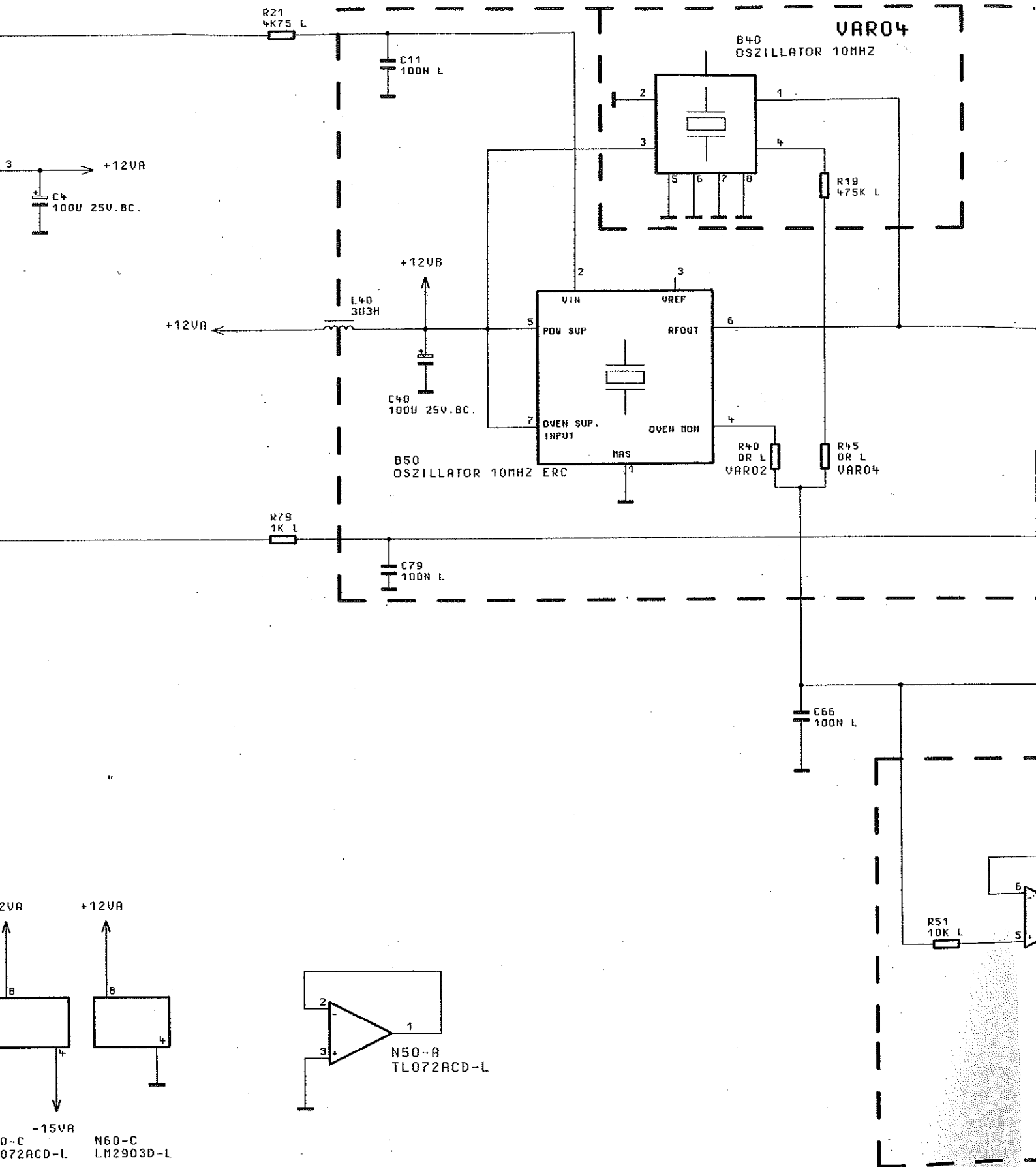

ACHTUNG: EGB!
 ELEKTROSTATISCH GEFÄHREDETE
 BAUELEMENTE ERFORDERN EINE
 BESONDERE HANDHABUNG.
ATTENTION ESD!
 ELECTROSTATIC SENSITIVE DEVICES
 REQUIRE A SPECIAL HANDLING

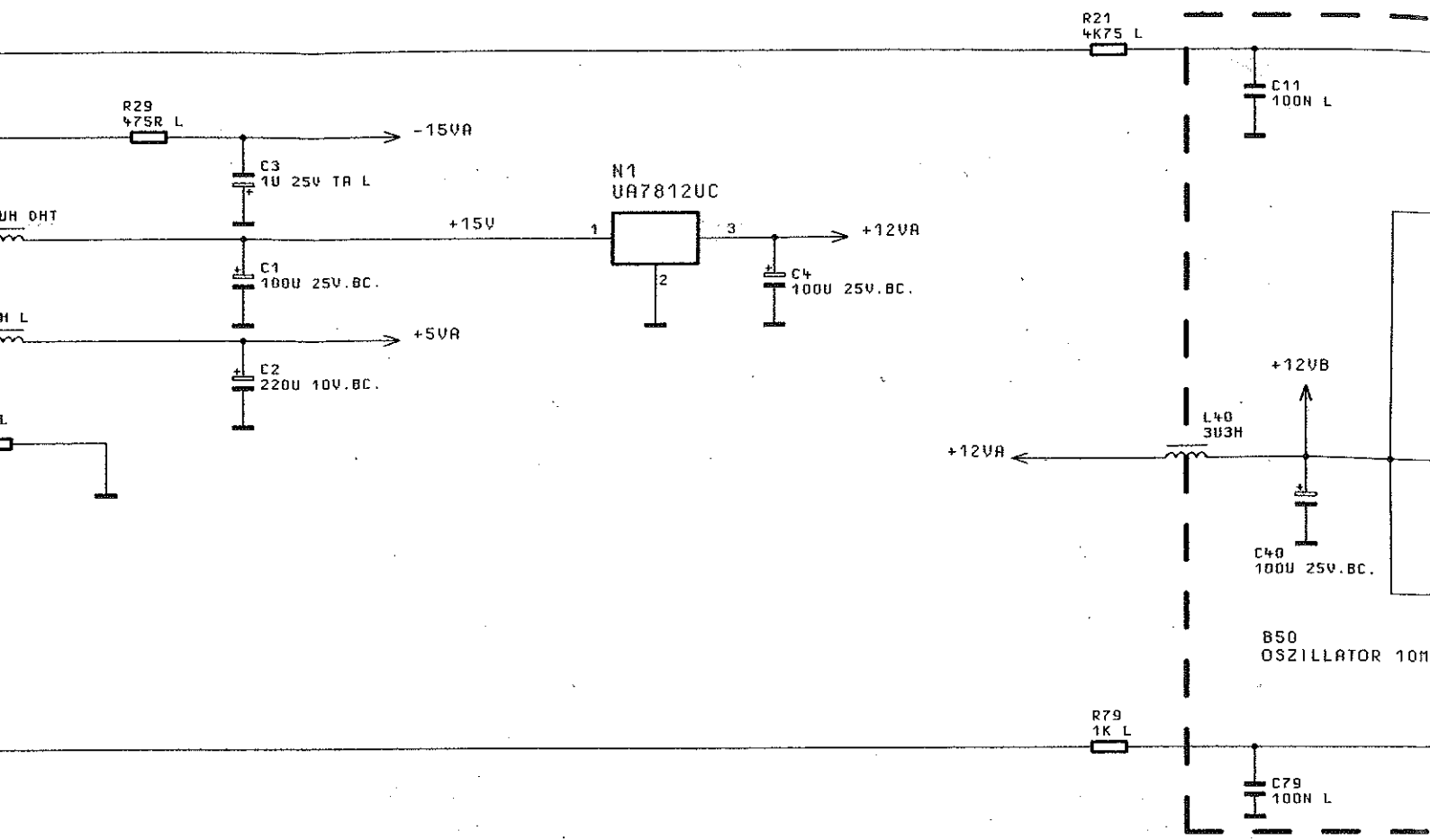

UF GILT FUER VAR.02,04

GRAM IS VALID FOR MOD.02,04

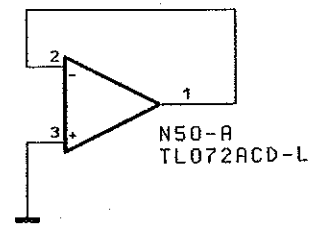
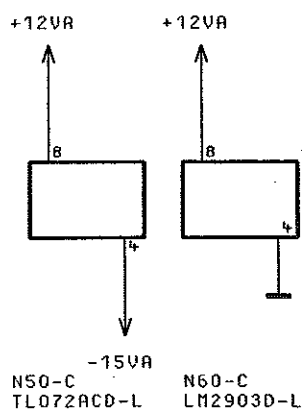

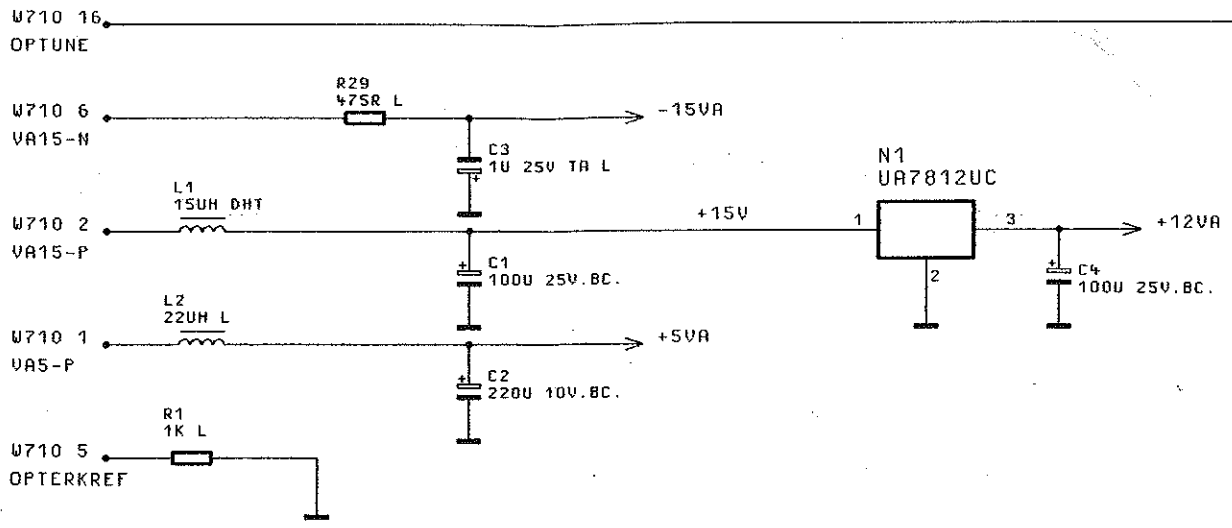

W710 4
REFOFF

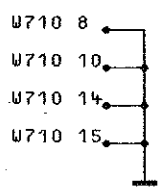

STROMLAUF GILT FUER VAR.02,04

CIRCUIT DIAGRAM IS VALID FOR MOD.02,04

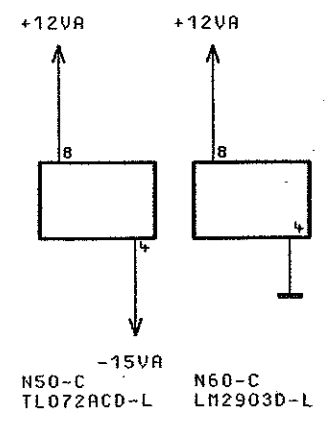

BEHALTEN MIR UNS ALLE RECHTE VOR

E

D

C

B

1

2

3

4

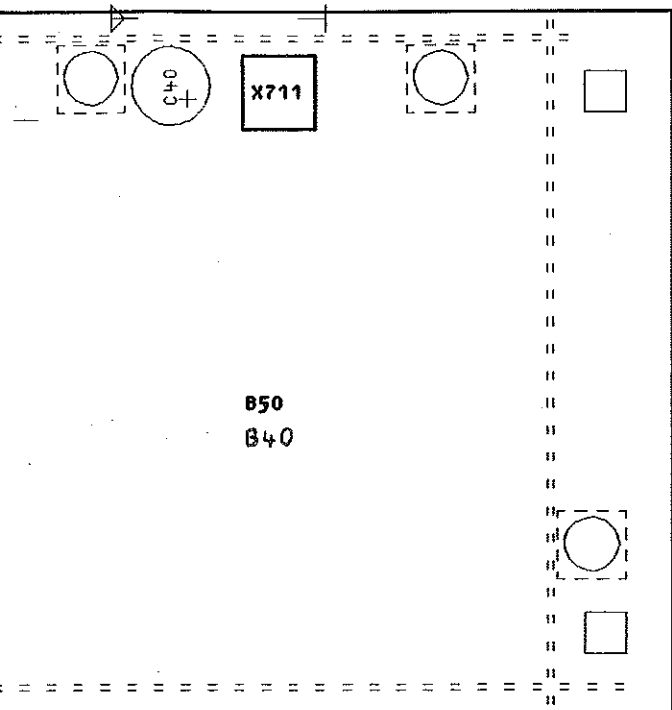

50

100

02/	49169 01	21.11.94	HO	16PK	TAG	NAME	BENENNUNG		Z
				BEARB.		HO	REFERENZOSZ. -OCXO		
				GEPR.			REFERENCE. -OSC. -OCXO		
				NORM					
				PLOTT	21.11.94				
						ZEICHN.-NR.		BLATT-NR.	
						ROHDE & SCHWARZ		1039.1027.01	ED
REND. IND.	RENDERUNGS- MITTEILUNG	DATUM	NAME	ZU GERÄT	SMY-B1	REG.I.V.	1039.0995	ERSTE Z.	V. BL.

5 A

6

7

8

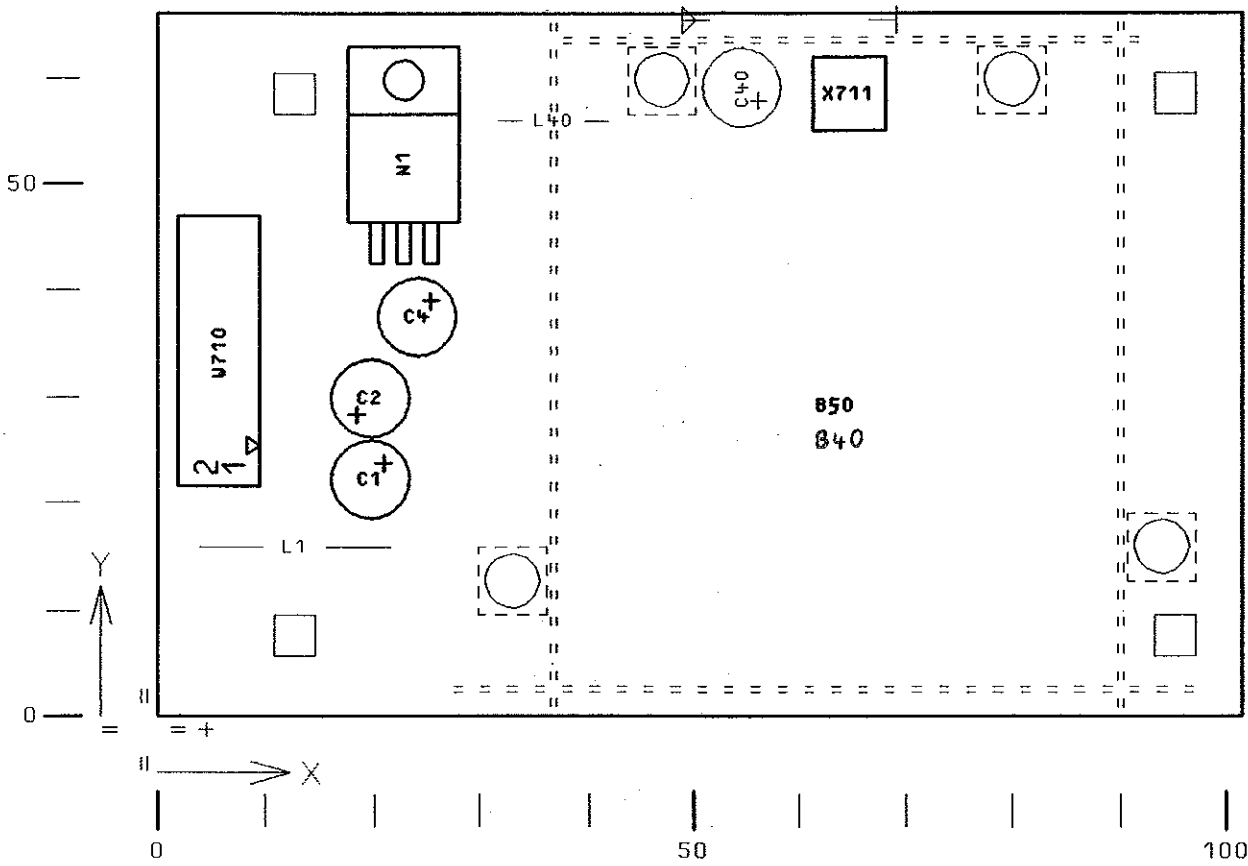

: EGB!
 CH GEFÄHRDETE
 ERFORDERN EINE
 HANDHABUNG.
 ON ESD!
 SENSITIVE DEVICES
 ECIAL HANDLING

BINDENDE ANGABEN UEBER VARIANTEN,
 TRIMMWERTE, BAUTEILWERTE UND
 NICHT BESTUECKTE BAUTEILE SIEHE SA.
 FOR BINDING INFORMATION ON MODELS,
 TRIMMING AND COMPONENTS VALUES AND
 NONFITTED COMPONENTS SEE PARTS LIST.

02/	49169 01	21.11.94	HO	1GPK	TAG	NAME	BENENNUNG
				BEARB.		HO	REF.
				GEPR.			REFER
				NORN			
				PLOTT	21.11.94		
/				 ROHDE & SCHWARZ			ZEICHN.-NR.
REND.	RENDERUNGS-	DATUM	NAME				ZU GERÄT
IND.	NITTEILUNG						1

FUER DIESE ZEICHNUNG BEHALTEN WIR UNS ALLE RECHTE VOR
 DIESE ZEICHNUNG IST EIN RECHNERAUSDRUCK, AENDERUNGEN KOENNEN NUR DURCH AENDERUNG DES DATENSATZES ERFOLGEN

F
E
D
C
B
A

DARSTELLUNG SEITE B
VIEW ON SIDE B



ACHTUNG: ESB!
 ELEKTROSTATISCH GEFAHRDETE
 BAUELEMENTE ERFORDERN EINE
 BESONDERE HANDHABUNG.
ATTENTION ESD!
 ELECTROSTATIC SENSITIVE DEVICES
 REQUIRE A SPECIAL HANDLING

BINDENDE ANGABEN UEBER VARIANTEN,
 TRIMMWERTE, BAUTEILWERTE UND
 NICHT BESTUECKTE BAUTEILE SIEHE
 FOR BINDING INFORMATION ON MODEL
 TRIMMING AND COMPONENTS VALUES
 NONFITTED COMPONENTS SEE PARTS L

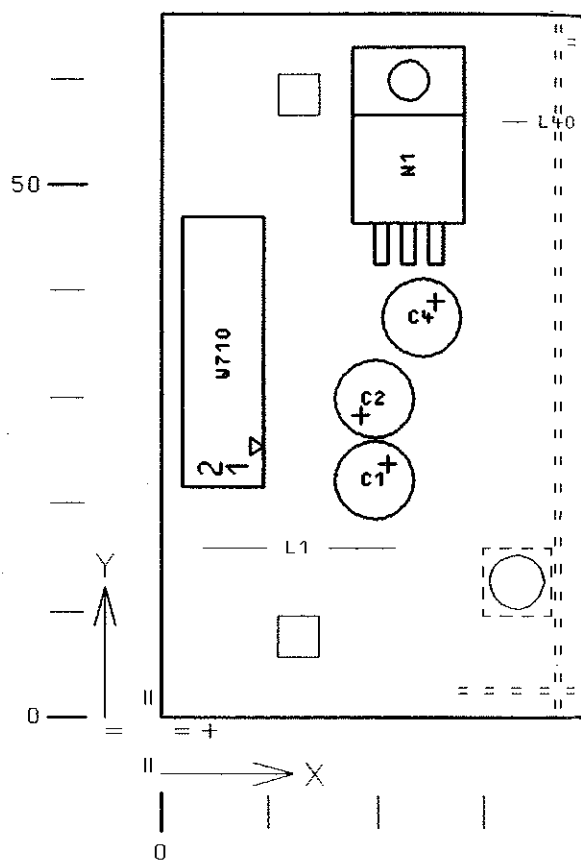

1 2 3 4

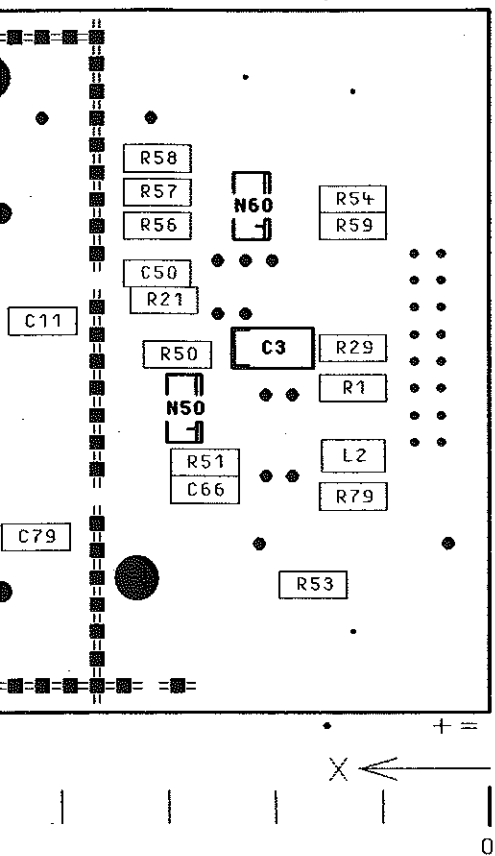

02/	49169 01	21.11.94	HO	1 GPK	TRG	NAME	BENENNUNG		Z
				BEARB.		HO	REFERENZOSZ. -OCXO		
				GEPR.			REFERENCE. -OSC. -OCXO		
				NORM					
				PLOTT	21.11.94				
/				 ROHDE & SCHWARZ			ZEICHN.-NR.		BLATT-NR.
REND. IND.	RENDERUNGS-NITTEILUNG	DATUM	NAME				1039.1027.01		ED
				ZU GERÄT	SMY-B1	REG. I. V.	1039.0995	ERSTE Z.	

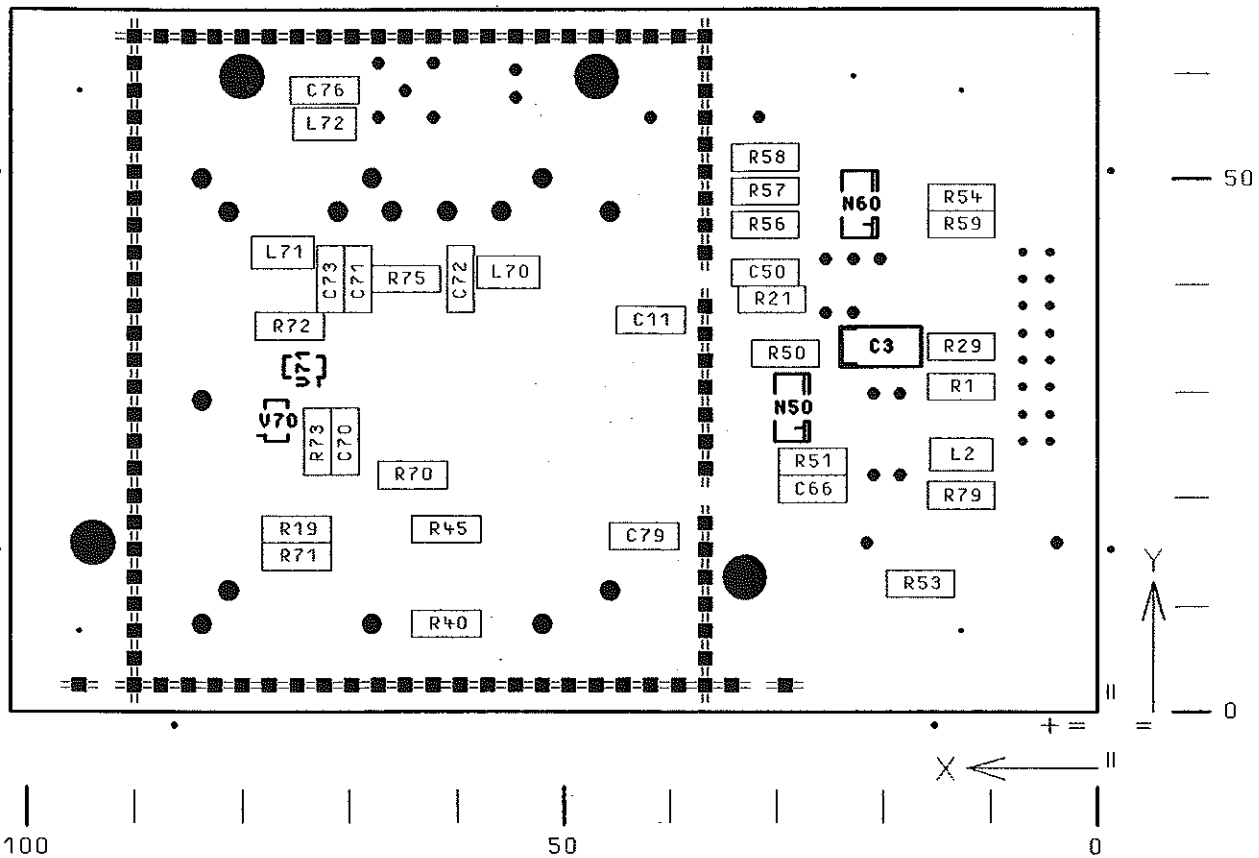

ACHTUNG: ESB!
 ELEKTROSTÄTISCH GEFAHRDETE
 BAUELEMENTE ERFORDERN EINE
 BESONDERE HANDHABUNG.
ATTENTION ESD!
 ELECTROSTATIC SENSITIVE DEVICES
 REQUIRE A SPECIAL HANDLING

BINDENDE ANGABEN UEBER VARIANTEN,
 TRIMMWERTE, BAUTEILWERTE UND
 NICHT BESTUECKTE BAUTEILE SIEHE SA.

FOR BINDING INFORMATION ON MODELS,
 TRIMMING AND COMPONENTS VALUES AND
 NONFITTED COMPONENTS SEE PARTS LIST.

02/	+9169 01	21.11.94	HO	16PK	TAG	NAME	BE	
				BEARB.		HO		
				GEPR.				
				NORM				
				PLOTT	21.11.94			
/							ZE	
REND. IND.	RENDERUNGS- MITTEILUNG	DATUM	NAME	 ZU GERÄT SMY-B1				RE

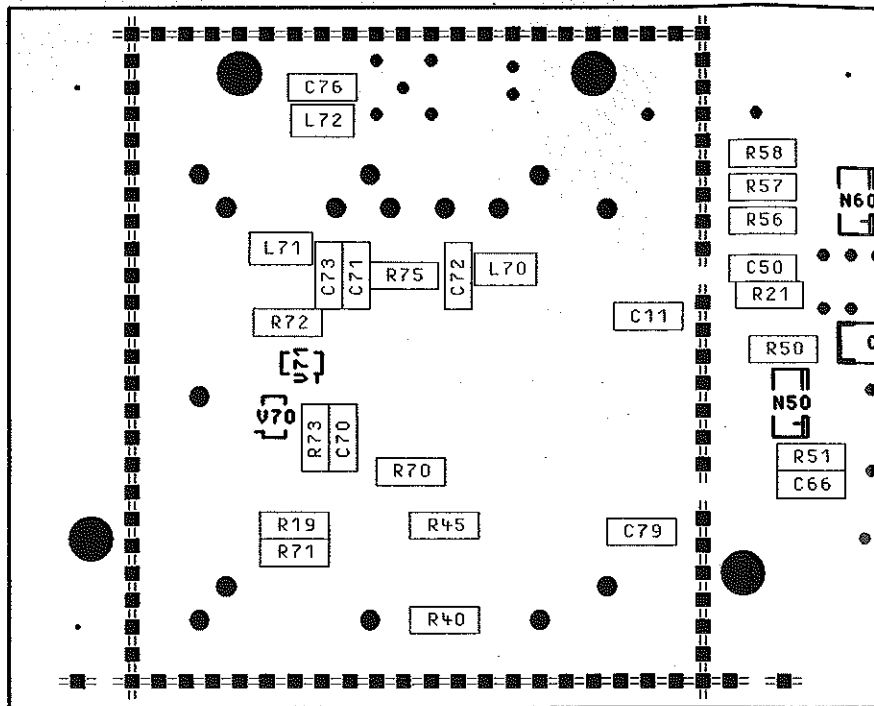

100

50

STELLUNG SEITE A
W ON SIDE A

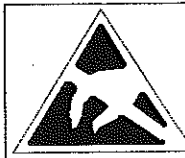

ACHTUNG: EGB!
ELEKTROSTATISCH GEFÄHRDETE
BAUELEMENTE ERFORDERN EINE
BESONDERE HANDHABUNG.
ATTENTION ESD!
ELECTROSTATIC SENSITIVE DEVICES
REQUIRE A SPECIAL HANDLING

BINDENDE ANGABEN UEBER VARIANTEN,
TRIMMWERTE, BAUTEILWERTE UND
NICHT BESTUECKTE BAUTEILE SIEHE SA.

FOR BINDING INFORMATION ON MODELS,
TRIMMING AND COMPONENTS VALUES AND
NONFITTED COMPONENTS SEE PARTS LIST.

02/	49169
REND.	RENDER
IND.	MITTE

F
E
D
C
B
A

FUER DIESE ZEICHNUNG BEHALTEN WIR UNS ALLE RECHTE VOR
DIESE ZEICHNUNG IST EIN SCHNITTZEICHNUNG. VERÄNDERUNGEN KÖNNEN NUR DURCH ÄNDERUNG DES DATENSATZES ERFOLGEN

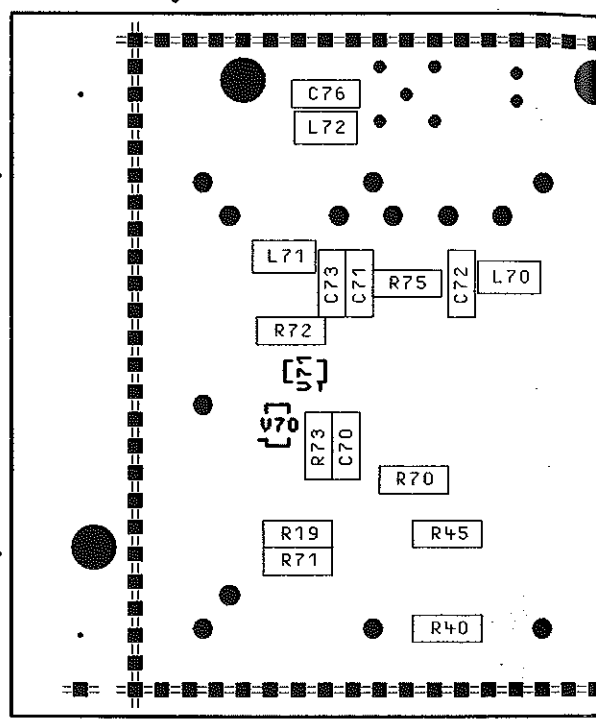

100 50

DARSTELLUNG SEITE A
VIEW ON SIDE A



ACHTUNG: ESD!
ELEKTROSTÄTISCH GEFÄHRDETE
BAUELEMENTE ERFORDERN EINE
BESONDERE HANDHABUNG.
ATTENTION ESD!
ELECTROSTATIC SENSITIVE DEVICES
REQUIRE A SPECIAL HANDLING

BINDENDE ANGABEN ÜBER VARIANTEN,
TRIMMWERTE, BAUTEILWERTE UND
NICHT BESTÜCKTE BAUTEILE SIEHE S
FOR BINDING INFORMATION ON MODEL
TRIMMING AND COMPONENTS VALUES AND
NONFITTED COMPONENTS SEE PARTS L

1 2 3 4



ROHDE & SCHWARZ

SERVICEUNTERLAGEN

Powermodul

1062.7240.01

Inhaltsverzeichnis

7 Prüfen und Instandsetzen der Baugruppe.....	5
7.1 Funktionsbeschreibung.....	5
7.2 Meßgeräte und Hilfsmittel.....	5
7.3 Fehlersuche.....	5
7.3.1 Fehler nur im Bereich $f_{RF} < 10$ MHz.....	6
7.3.2 Fehler nur im Bereich $f_{RF} > 10$ MHz.....	6
7.3.3 Fehler im Bereich $9 \text{ kHz} < f_{RF} \leq 2080$ MHz.....	6
7.4 Prüfen und Abgleich.....	6
7.4.1 Prüfen der Stromaufnahme.....	7
7.4.2 Prüfen der Arbeitspunkte der Verstärkerstufen.....	7
7.4.3 Prüfen der Ansteuerung des Pulsmodulators.....	7
7.4.4 Prüfen der Detektorspannung am Ausgang VDETPOW.....	8
7.4.5 Abgleich der Detektor-Linearität am Ausgang FPOW.....	8
7.5 Zerlegung und Zusammenbau.....	8
7.6 Endprüfung.....	9
7.6.1 Prüfen des maximalen Ausgangspegels.....	9
7.6.2 Prüfen des Oberwellenabstandes.....	9
7.6.3 Prüfen der Pegel-Dynamik der Pulsmodulation.....	9
7.6.4 Prüfen der Schaltzeiten der Pulsmodulation.....	10
7.6.5 Prüfen der Pegelgenauigkeit.....	10
7.7 Externe Schnittstellen.....	10

Schaltteilliste
Koordinatenliste
Stromlauf
Bestückungsplan

7.1 Funktionsbeschreibung

Das RF-Signal vom Ausgangsteil OPUY1 bzw. OPUY2 am Eingang FOPU wird mit einem Signalteiler (R91, R92) geteilt und in identischen Zweigen verstärkt. Jeder Zweig beinhaltet einen Pulsmodulator gefolgt von einem RF-Verstärker. Ein Verstärkerausgang geht über den Ausgang FPOW zur Eichleitung, der andere zum Detektor (V13). Die RF-Spannung wird dort gleichgerichtet. Die Richtspannung wird linearisiert (N6) und geht über den Ausgang VDETPOW zum Motherboard und von dort zum Ausgangsteil OPUY1 bzw. OPUY2 als Istwert für die Amplitudenregelung im Frequenzbereich $f > 10$ MHz.

Nur der Pulsmodulator zum RF-Verstärker 1 wird angesteuert, der andere bleibt immer im ON-Zustand. Die Ansteuerung erfolgt über den Eingang PULSE. Leerlauf oder High-Pegel am Eingang ergeben RF ON, Low ergibt RF OFF. Diese Polarität kann durch Stecken der Brücke P1-P2 invertiert werden. Die Verstärker N1 und N2 setzen das TTL-Signal auf die Steuerpegel 0 V/-8 V für die GaAs-Schalter D2 und D3 um.

Die RF-Verstärker werden aus Konstantstromquellen V4 und V5 gespeist, die Drainspannungen werden über die Verstärker N3 und N4 geregelt. Die Verstärkerstufen V11 und V12 haben eine Verstärkung von ca. 10 dB. Die Pulsmodulatoren vor den Verstärkerstufen haben eine Dämpfung von ca. 2 dB bei 2 GHz. Der Signalteiler (R91, R92) hat eine Durchgangsdämpfung von 6 dB.

7.2 Meßgeräte und Hilfsmittel

- Spektrumanalysator (z.B. FSBS)
- Oszilloskop (z.B. BOL)
- Gleichspannungsmessgerät (Multimeter, z.B. UDL33)
- RF-Pegelmesser (z.B. NRVD mit Meßkopf Z51)
- 10 dB-Dämpfungsglied mit N-Anschlüssen (z.B. DNF)
- Durchführungsabschluß 50 Ohm (z.B. RAD)

7.3 Fehlersuche

Vor dem Öffnen des Gerätes ist es zweckmäßig, zuerst einmal die LEVEL PRESET-Kalibrierung durchzuführen und an Hand der Diagnosespannungen mögliche Fehlerquellen zu lokalisieren. Mit der Spezialfunktion 102 (Detektorspannung Ausgang FOPU) kann die RF-Quelle für das Powermodul kontrolliert werden: bei einem RF-Pegel von -30 dBm und RF-Frequenzen > 10 MHz liegen typische Spannungswerte im Bereich 0.7 ... 1.3 V.

7.3.1 Fehler nur im Bereich $f_{RF} < 10 \text{ MHz}$

falscher RF-Pegel an X4 FPOW	Prüfe Signalteiler R91/R92, Pulsmodulator D2/D3 und RF-Amplifier 1 bei $f = 100 \text{ kHz}$ mit Oszilloscope.
schlechter AM-Klirrfaktor	Prüfe die Stromquelle V4 und die Drainspannungsregelung N3.

7.3.2 Fehler nur im Bereich $f_{RF} > 10 \text{ MHz}$

falscher RF-Pegel an X4 FPOW	Die Pulsmodulatoren D2/D3 und D4/D5 oder die RF-Verstärker 1 und 2 haben unterschiedliche Verstärkung, oder die RF-Spannung am Ausgang von RF Amplifier 2 wird nicht richtig gleichgerichtet. Prüfe Detektor und Linearisierungsschaltung.
AM-Klirrfaktor zu groß	Prüfen und Abgleich von Detektor und Linearisierungsschaltung.

7.3.3 Fehler im Bereich $9 \text{ kHz} < f_{RF} \leq 2080 \text{ MHz}$

kein RF-Pegel an X4 FPOW	Die Steuerspannung des AM-Modulators (Spezialfunktion 107) muß jetzt $> 12 \text{ V}$ sein, sonst arbeitet die Pegelregelung nicht richtig oder der Führungswert vom RFLEV-D/A-Wandler ist falsch (der Fehler läge dann im Ausgangsteil OPUY1 oder OPUY2). Prüfe Signalteiler R91/R92, Pulsmodulator D2/D3 und RF-Amplifier 1 bei $f = 100 \text{ kHz}$ mit Oszilloscope.
Oberwellen zu groß	Prüfe die Stromquelle V4 und die Drainspannungsregelung N3.
AM-Klirrfaktor zu groß	Prüfen und Abgleich von Detektor und Linearisierungsschaltung.
Pulsmodulation mit falscher Polarität	Brücke auf P1-P2 darf nicht gesteckt sein, EXOR-Funktion von D1 prüfen
Pulsmodulation nicht möglich oder falsche Anstiegs- bzw. Abfallzeiten	Steuersignale in der Signalkette D1, N1 und N2 bis D2 und D3 prüfen
zu geringes Ein/Aus-Verhältnis bei Pulsmodulation	D2 und D3 prüfen, RC-Tiefpässe der Ansteuerleitungen kontrollieren

7.4 Prüfen und Abgleich

7.4.1 Prüfen der Stromaufnahme

- Einstellung: PRESET

Die Ströme können entweder am Stecker X1 oder durch den Spannungsabfall an Meßwiderständen nachgemessen werden. Bei mehreren Meßwiderständen sind die Teilströme zu addieren.

Anschluss	Spannung	Stromaufnahme	Widerstand (2 Ohm)
X1.11 und X1.12	+5 V	35 .. 45 mA	R66
X1.13 und X1.14	+15 V	340 .. 360 mA	R67 und R68
X1.15 und X1.16	-15 V	45 .. 55 mA	R69, R70 und R72

7.4.2 Prüfen der Arbeitspunkte der Verstärkerstufen

Prüfpunkt	Sollspannung	Bemerkung
V11 Drain	6.60 ± 0.5V	RF AMPLIFIER 1
V11 Gate	-1.0 ± 0.5V	RF AMPLIFIER 1
V4 Kollektor	7.25 ± 0.2V	Stromquelle
U15VA1 - V4 Emitter	1.21 ± 0.02V	I = 150 mA
V12 Drain	6.60 ± 0.5V	RF AMPLIFIER 1
V12 Gate	-1.0 ± 0.5V	RF AMPLIFIER 1
V5 Kollektor	7.25 ± 0.2V	Stromquelle
U15VA2 - V5 Emitter	1.21 ± 0.02V	I = 150 mA

7.4.3 Prüfen der Ansteuerung des Pulsmodulators

Die Spannungswerte nach folgender Tabelle kontrollieren: High = 5 V, Low = 0 V.

P1-P2	PULSE	D1/10	D1/8	D1/3	D1/6	N1/6	N2/6	D2/5	D3/5	D2/4	D3/4
nicht gesteckt	High	High	Low	Low	High	0 V	-7.9 V	0 V	0 V	-7.9 V	-7.9 V
gesteckt	Low	High	Low	Low	High	0 V	-7.9 V	0 V	0 V	-7.9 V	-7.9 V
nicht gesteckt	Low	Low	High	High	Low	-7.9 V	0 V	-7.9 V	-7.9 V	0 V	0 V
gesteckt	High	Low	High	High	Low	-7.9 V	0 V	-7.9 V	-7.9 V	0 V	0 V

Brücke P1-P2 entfernen.

7.4.4 Prüfen der Detektorspannung am Ausgang VDETPOW

- Einstellung: RF 100 MHz
Spezialfunktion 49 einschalten (Pegelkorrektur aus)

_ Gleichspannung an VDETPOW nach folgender Tabelle kontrollieren:

RF-Pegel in dBm	-30	11.1	13	16	19
Spannung in V	2.0	1.27	1.58	2.23	3.14

Spezialfunktion 50 einschalten (Pegelkorrektur ein)

7.4.5 Abgleich der Detektor-Linearität am Ausgang FPOW

- Einstellung: RF 100 MHz
LEVEL 11.1 dBm

_ Ausgangspegel am RF-Ausgang des Gerätes messen und merken (= Referenzpegel)

- Einstellung: Spezialfunktion 1 einschalten
(unterbrechungsfreie Pegeleinstellung)
LEVEL -8.9 dBm

_ Mit POT R36 so abgleichen, daß der gemessene Pegel 20 dB unter dem zuvor gemessenen Referenzpegel liegt. Abgleich einmal wiederholen, da sich der Referenzwert mit R36 ändert; die Genauigkeit der 20dB-Absenkung soll nach dem Abgleich ± 0.1 dB erreichen.

7.5 Zerlegung und Zusammenbau

Oberer Gerätedeckel entfernen. Die Baugruppe ist mit einer Schraube am Rahmen befestigt und an der Querwand gesteckt. Nach dem Entfernen der Schraube und dem Lösen der Koax-Verbindungen an X2, X3, X4 und X5 sowie des Steckers X1 kann die Baugruppe entnommen werden.

7.6 Endprüfung

7.6.1 Prüfen des maximalen Ausgangspegels

- Einstellung: LEVEL 25 dBm
- _ An X226 FOPU einen Leistungsmesser anschließen, dabei auf die max. zulässige RF-Leistung achten! Ggf. muß ein geeignetes Dämpfungsglied vorgeschaltet werden..
- _ RF-Frequenz von 9 kHz bis 2080 MHz variieren.
- Der RF-Pegel muß > 20 dBm bleiben.

7.6.2 Prüfen des Oberwellenabstandes

- Einstellung: LEVEL 16 dBm
- _ An die Geräte-RF-Buchse einen Spektrumanalysator anschließen.
- _ Der Pegel der Harmonischen muß < -25 dBc sein.

7.6.3 Prüfen der Pegel-Dynamik der Pulsmodulation

- Einstellung: LEVEL 19 dBm
- _ An die Geräte-RF-Buchse einen Spektrumanalysator anschließen.
- _ An die PULSE-Buchse 0 V anlegen.
- _ Der RF-Pegel muß bei 70 MHz < -51 dBm sein.
- _ Der RF-Pegel darf im Frequenzbereich 70 MHz < f < 520 MHz linear bis auf < -46 dBm ansteigen.
- _ Der RF-Pegel muß im Frequenzbereich 520 MHz < f < 800 MHz < -46 dBm bleiben.
- _ Der RF-Pegel darf im Frequenzbereich 800 MHz < f < 2080 MHz linear bis auf < -16 dBm ansteigen.

Der typische RF OFF-Pegel liegt 10 dB unter den angegebenen Werten.

7.6.4 Prüfen der Schaltzeiten der Pulsmodulation

- Einstellung: LEVEL 19 dBm
 RF 50 MHz

An die Geräte-RF-Buchse ein Oszilloskop mit 50 Ohm Eingangswiderstand anschließen.

- _ An die PULSE-Buchse ein TTL-Signal mit $f = 1$ MHz anlegen.
- _ Die Anstiegs- und Abfallzeit (10/90%) der Einhüllenden des RF-Signals muß < 20 ns sein.
- _ Die Verzögerungszeit der Einhüllenden gegenüber dem Steuersignal am PULSE Eingang (50%) muß < 200 ns sein.

7.6.5 Prüfen der Pegelgenauigkeit

- Einstellung: LEVEL 0 dBm
 RF 9 kHz ... 2080 MHz

- _ An die Geräte-RF-Buchse einen Leistungsmesser anschließen.
- _ Der RF-Pegel muß $0 \text{ dBm} \pm 1 \text{ dB}$ betragen. Typisch sind Abweichungen $< \pm 0.1 \text{ dB}$ nach der Kalibrierung des Ausgangspegels (siehe dazu Band 1 Kapitel 6.4).

7.7 Externe Schnittstellen

Pin	Name	Ein/Ausgang	Herkunft/Ziel	Wertebereich	Signalbeschreibung
X1.01	GND				
X1.02	SERDAT	Eingang	CPU	HCMOS-Pegel	wird nicht verwendet
X1.03	GND				
X1.04	SERCLK	Eingang	CPU	HCMOS-Pegel	wird nicht verwendet
X1.05	GND				
X1.06	ELSTB	Eingang	CPU	HCMOS-Pegel	wird nicht verwendet
X1.07	GND				
X1.08	OVERLOAD	Ausgang	CPU	HCMOS-Pegel	wird nicht verwendet
X1.09	GND				
X1.10	PULSE-INV	Eingang			wird nicht verwendet
X1.11	VA-5P	Eingang	Netzteil X21.5	5.10V..5.25V	Versorgungsspannung analog
X1.12	VA-5P	Eingang	Netzteil X21.5	5.10V..5.25V	Versorgungsspannung analog
X1.13	VA15-P	Eingang	Netzteil X21.13	14.80 V...15.75 V	Versorgungsspannung analog
X1.14	VA15-P	Eingang	Netzteil X21.13	14.80 V...15.75 V	Versorgungsspannung analog
X1.15	VA15-N	Eingang	Netzteil X21.19	-15.75V...-14.85V	Versorgungsspannung analog
X1.16	VA15-N	Eingang	Netzteil X21.19	-15.75V...-14.85V	Versorgungsspannung analog
X2	FOPU	Eingang	OPUY1/2	11 ... 19 dBm	9 kHz ... 2080 MHz
X3	PULSE	Eingang	Rückwand	HCMOS-Pegel	DC ... 1 MHz
X4	FPOW	Ausgang	Eichleitung X2	11 ... 19 dBm	9 kHz ... 2080 MHz
X5	VDETPOW	Ausgang	OPUY1/2	0 ... 5 V	DC ... 100 kHz



ROHDE & SCHWARZ

SERVICE INSTRUCTIONS

Power Module

1062.7240.01

Contents

7 Testing and Repair of the Module.....	5
7.1 Function Description.....	5
7.2 Test Instruments and Utilities.....	5
7.3 Troubleshooting.....	5
7.3.1 Errors Occurring Only in the Range $f_{RF} < 10$ MHz.....	6
7.3.2 Errors Occurring Only in the Range $f_{RF} > 10$ MHz.....	6
7.3.3 Errors in the Range $9 \text{ kHz} < f_{RF} \leq 2080$ MHz.....	6
7.4 Testing and Adjustment.....	6
7.4.1 Testing the Power Consumption.....	7
7.4.2 Testing the Operating Points of the Amplifier Stages.	7
7.4.3 Testing the Pulse-modulator Control.....	7
7.4.4 Testing the Detector Voltage at the Output VDETPOW...	8
7.4.5 Adjusting the Detector Linearity at the Output FPOW..	8
7.5 Disassembly and Assembly.....	8
7.6.1 Maximum Output Level Check.....	9
7.6.2 Harmonics Suppression Check.....	9
7.6.3 Checking the Dynamic Range of Pulse Modulation.....	9
7.6.4 Checking Switching Times of Pulse Modulation.....	10
7.6.5 Level Accuracy Check.....	10
7.7 External Interfaces.....	10

Parts list
List of coordinates
Circuit diagram
Component layout diagram

7.1 Function Description

The RF signal from the output module OPUY1 or OPUY2 is provided at the input FOPU, divided by means of a signal divider (R91, R92) and amplified in identical paths. Each path contains a pulse modulator which is followed by an RF amplifier. One amplifier output passes via the FPOW output to the attenuator, the other one to the detector (V13). The RF voltage is rectified, there. The directional voltage is linearized (N6) and routed via the VDETPOW output to the motherboard and then to the output unit OPUY1 or OPUY2 as actual value for amplitude control in the frequency range $f > 10$ MHz.

Only the pulse modulator followed by the RF amplifier 1 is controlled, the other one assumes always the On state. Control is effected via the PULSE input. Level (EMF) or HIGH level at the input lead to RF ON, Low means RF OFF. This polarity may be inverted by plugging on the jumper P1-P2. The amplifiers N1 and N2 convert the TTL signal to the control level 0 V/-8 V for the GaAs switches D2 and D3.

The RF amplifiers are fed from constant-current sources V4 and V5, the drain voltages are regulated via the amplifiers N3 and N4. The amplifier stages V11 and V12 provide a gain of approx. 10 dB. The pulse modulators preceding the amplifier stages have an attenuation of approx. 2 dB with 2 GHz. The signal divider (R91, R92) has a transmission loss of 6 dB.

7.2 Test Instruments and Utilities

- Spectrum analyzer (e.g., FSBS)
- Oscilloscope (e.g., BOL)
- DC voltmeter (multimeter, e.g., UDL33)
- RF level meter (e.g., NRVD with sensor Z51)
- 10-dB attenuator with N connectors (e.g., DNF)
- 50- Ω termination (e.g., RAD)

7.3 Troubleshooting

Before opening the instrument, it is useful to first perform the LEVEL PRESET calibration and localize possible error sources using the diagnostic voltages. The special function 102 (detector voltage FOPU output) allows for checking the RF source for the Power Module: with a RF level of -30 dBm and RF frequencies > 10 MHz the typical voltage values are in the range from 0.7 to 1.3 V.

7.3.1 Errors Occurring Only in the Range $f_{RF} < 10$ MHz

incorrect RF level at X4 FPOW Check signal divider R91/R92, pulse modulator D2/D3 and RF amplifier 1 with $f = 100$ kHz using an oscilloscope.

bad AM distortion Check current source V4 and the drain-voltage control N3.

7.3.2 Errors Occurring Only in the Range $f_{RF} > 10$ MHz

incorrect RF level at X4 FPOW The gain of pulse modulators D2/D3 and D4/D5 or of the RF amplifiers 1 and 2 is not equal or the RF voltage at the output of RF amplifier 2 is not rectified correctly. Check detector and linearization circuit.

AM distortion too high Test and adjust detector and linearization circuit.

7.3.3 Errors in the Range 9 kHz $< f_{RF} \leq 2080$ MHz

no level at X4 FPOW The control voltage of the AM modulator (special function 107) must be > 12 V, otherwise, the level control does not work correctly or the reference value of RFLEV D/A converter is incorrect (the error is then located in the output units OPUY1 or OPUY2).
Check signal divider R91/R92, pulse modulator D2/D3 and RF amplifier 1 with $f = 100$ kHz using an oscilloscope.

harmonics too high Check the current source V4 and the drain-voltage control N3.

AM distortion too high Test and adjust detector and linearization circuit.

pulse modulation with incorrect polarity Jumper P1-P2 must not be plugged, check EXOR function of D1

pulse modulation not possible or incorrect rise and/or fall times Check control signals in the signal chain D1, N1 and N2 to D2 and D3

on/off-ratio with pulse modulation too low Check D2 and D3 and RC lowpasses of the control lines

7.4 Testing and Adjustment

7.4.1 Testing the Power Consumption

- Setting: PRESET

The currents can either be measured at the connector X1 or by means of the voltage drop at measurement resistors. If several measurement resistors are provided, the individual currents have to be added.

Connector	Voltage	Power consumption	Resistor (2 Ω)
X1.11 and X1.12	+5 V	35 to 45 mA	R66
X1.13 and X1.14	+15 V	340 to 360 mA	R67 and R68
X1.15 and X1.16	-15 V	45 to 55 mA	R69, R70 and R72

7.4.2 Testing the Operating Points of the Amplifier Stages

Test point	Rated voltage	Remark
V11 Drain	6.60 ± 0.5V	RF AMPLIFIER 1
V11 Gate	-1.0 ± 0.5V	RF AMPLIFIER 1
V4 Collector	7.25 ± 0.2V	current source
U15VA1 - V4 Emitter	1.21 ± 0.02V	I = 150 mA
V12 Drain	6.60 ± 0.5V	RF AMPLIFIER 1
V12 Gate	-1.0 ± 0.5V	RF AMPLIFIER 1
V5 Collector	7.25 ± 0.2V	current source
U15VA2 - V5 Emitter	1.21 ± 0.02V	I = 150 mA

7.4.3 Testing the Pulse-modulator Control

Check the voltages according to the table below: High = 5 V, Low = 0 V.

P1-P2	PULSE	D1/10	D1/8	D1/3	D1/6	N1/6	N2/6	D2/5	D3/5	D2/4	D3/4
not connected	High	High	Low	Low	High	0 V	-7.9 V	0 V	0 V	-7.9 V	-7.9 V
connected	Low	High	Low	Low	High	0 V	-7.9 V	0 V	0 V	-7.9 V	-7.9 V
not connected	Low	Low	High	High	Low	-7.9 V	0 V	-7.9 V	-7.9 V	0 V	0 V
connected	High	Low	High	High	Low	-7.9 V	0 V	-7.9 V	-7.9 V	0 V	0 V

Remove jumper P1-P2.

7.4.4 Testing the Detector Voltage at the Output VDETPOW

- Setting: RF 100 MHz
Switch on special function 49 (level correction inactive)

_ Check dc voltage at VDETPOW according to the following table:

RF level in dBm	-30	11.1	13	16	19
Voltage in V	2.0	1.27	1.58	2.23	3.14

Switch on special function 50 (level correction active)

7.4.5 Adjusting the Detector Linearity at the Output FPOW

- Setting: RF 100 MHz
LEVEL 11.1 dBm

_ Measure and note output level at the RF output of the instrument (= reference level)

- Setting: Switch on special function 1 (non-interrupting level setting)
LEVEL -8.9 dBm

_ Use POT R36 such that the measured level is 20 dB below the previously measured reference level. Repeat adjustment once, since the reference value changes by using R36; the accuracy of the 20-dB attenuation must be ± 0.1 dB.

7.5 Disassembly and Assembly

Remove top cover. The module is screwed to the frame and plugged in the transverse panel. The module can be removed after removing the screw and disconnecting the coaxial connections at X2, X3, X4, X5 and the connector X1.

7.6 Final Test

7.6.1 Maximum Output Level Check

- Setting: LEVEL 25 dBm
- _ Connect a power meter to X226 FOPU, make sure not to exceed the maximum RF power permitted! If necessary, an appropriate attenuator pad must be series-connected.
- _ Vary the RF frequency from 9 kHz to 2080 MHz.
The RF level must remain > 20 dBm.

7.6.2 Harmonics Suppression Check

- Setting: LEVEL 16 dBm
- _ Connect a spectrum analyzer to the RF connector of the instrument.
- _ The level of the harmonics must be < -25 dBc.

7.6.3 Checking the Dynamic Range of Pulse Modulation

- Setting: LEVEL 19 dBm
- _ Connect a spectrum analyzer to the RF connector of the instrument.
- _ Apply 0 V to the PULSE connector.
- _ The RF level must be < -51 dBm with 70 MHz.
- _ The RF level may increase linearly up to < -46 dBm in the frequency range $70 \text{ MHz} < f < 520 \text{ MHz}$.
- _ The RF level must remain < -46 dBm in the frequency range $520 \text{ MHz} < f < 800 \text{ MHz}$.
- _ The RF level may increase linearly up to < -16 dBm in the frequency range $800 \text{ MHz} < f < 2080 \text{ MHz}$.

The typical RF-OFF level is 10 dB below the given values.

7.6.4 Checking Switching Times of Pulse Modulation

- Setting: LEVEL 19 dBm
 RF 50 MHz

Connect an oscilloscope with an input impedance of 50 Ω to the RF connector of the instrument.

- _ Apply a TTL signal with $f = 1$ MHz to PULSE.
- _ The rise and fall time (10/90%) of the RF-signal envelope must be < 20 ns.
- _ The delay of the envelope compared to the control signal at the PULSE input (50%) must be < 200 ns.

7.6.5 Level Accuracy Check

- Setting: LEVEL 0 dBm
 RF 9 kHz to 2080 MHz

- _ Connect a power meter to the RF connector of the instrument.
- _ The RF level must be $0 \text{ dBm} \pm 1 \text{ dB}$. Typical deviations after calibration of the output level are $< \pm 0.1 \text{ dB}$ (cf. To Vol. 1, Section 6.4).

7.7 External Interfaces

Pin	Name	Input/Output	Origin/Destination	Range	Signal description
X1.01	GND				
X1.02	SERDAT	Input	CPU	HCMOS level	not used
X1.03	GND				
X1.04	SERCLK	Input	CPU	HCMOS level	not used
X1.05	GND				
X1.06	ELSTB	Input	CPU	HCMOS level	not used
X1.07	GND				
X1.08	OVERLOAD	Output	CPU	HCMOS level	not used
X1.09	GND				
X1.10	PULSE-INV	Input			
X1.11	VA-5P	Input	Power supply X21.5	5.10 V to 5.25 V	not used
X1.12	VA-5P	Input	Power supply X21.5	5.10 V to 5.25 V	Analog supply voltage
X1.13	VA15-P	Input	Power supply X21.13	14.80 V to 15.75 V	Analog supply voltage
X1.14	VA15-P	Input	Power supply X21.13	14.80 V to 15.75 V	Analog supply voltage
X1.15	VA15-N	Input	Power supply X21.19	-15.75 V to -14.85 V	Analog supply voltage
X1.16	VA15-N	Input	Power supply X21.19	-15.75 V to -14.85 V	Analog supply voltage
X2	FOPU	Input	OPUY1/2	11 to 19 dBm	9 kHz to 2080 MHz
X3	PULSE	Input	Rear panel	HCMOS level	DC to 1 MHz
X4	FPOW	Output	Attenuator X2	11 to 19 dBm	9 kHz to 2080 MHz
X5	VDETPOW	Output	OPUY1/2	0 to 5 V	DC to 100 kHz

**Schaltteillisten
numerisch geordnet
Part lists
in numerical order
Listes des pièces détachées
par numéros de référence**

Für diese Unterlage behalten
wir uns alle Rechte vor.

Kanz. Comp. No.	Benennung Designation	Sachnummer Stock No.	Hersteller Manufacturer	Bezeichnung Designation	enthalten in contained in	
.	XX VARIANTENERKLAERUNG IDENTIFICATION OF MODELS VAR02=GRUNDAUSFUEHRUNG MOD02=BASIC_MODEL					
C1	CC 33NF+-10% 25V HDK 0603 ERAMIC CHIP CAPACITOR	1051.4697.00	AVX	CM105X7R333K25AT		
..9						
C10	CC 39PF+-1% 50VNPO 0603 SMD-CERAMIC-CAPACITOR	0009.9730.00	VITRAMON	VJ0603A *** FXAT		
..13						
C14	CC 33NF+-10% 25V HDK 0603 ERAMIC CHIP CAPACITOR	1051.4697.00	AVX	CM105X7R333K25AT		
..29						
C30	CE 10UF+-20%35V RUND SMD SMD-ELECTROLYTIC CAPACIT.	CE 0009.5605.00	PANASONIC	EEV HB 1V 100P		
C31	CE 10UF+-20%35V RUND SMD SMD-ELECTROLYTIC CAPACIT.	CE 0009.5605.00	PANASONIC	EEV HB 1V 100P		
C32	CE 10UF +-10% 25V 7343 TANTALUM SMD-CAPACITOR NICHT BESTUECKT	CE 0007.7246.00	SPRAGUE	293D 106 X9 025 D2T		
C33	CE 10UF +-10% 25V 7343 TANTALUM SMD-CAPACITOR NICHT BESTUECKT	CE 0007.7246.00	SPRAGUE	293D 106 X9 025 D2T		
C34	CC 10PF+-0,1 50V NPO 0603 SMD-CERAMIC-CAPACITOR	CC 0009.4567.00	AVX	0603 5A *** BAT00J		
C35	CE 10UF +-10% 10V 6032 TANTALUM SMD-CAPACITOR NICHT BESTUECKT	CE 0007.7281.00	KEMET	T491 C 106 K 010 AS		
C36	CE 10UF+-20%35V RUND SMD SMD-ELECTROLYTIC CAPACIT.	CE 0009.5605.00	PANASONIC	EEV HB 1V 100P		
C37	CC 15PF+-1% 50VNPO 0603 SMD-CERAMIC-CAPACITOR	0009.8227.00	VITRAMON	VJ0603A *** BXAT		
C38	CC 15PF+-1% 50VNPO 0603 SMD-CERAMIC-CAPACITOR	0009.8227.00	VITRAMON	VJ0603A *** BXAT		
C39	CC 33NF+-10% 25V HDK 0603 ERAMIC CHIP CAPACITOR	1051.4697.00	AVX	CM105X7R333K25AT		
C40	CC 47PF+-1% 50VNPO 0603 SMD-CERAMIC-CAPACITOR	CC 0009.4644.00	VITRAMON	VJ0603A *** FXAT		
C41	CE 1UF +-10% 10V 1206 TANTALUM-SMD-CAPACITOR	CE 0007.7252.00	SPRAGUE	293D 105 X9 010 D2T		
C42	CE 1UF +-10% 25V EIA3528 TANTALUM SMD-CAPACITOR	CE 0007.7217.00	SPRAGUE	293D 105 X9 025 B2T		
..44						
C45	CE 1UF +-10% 10V 1206 TANTALUM-SMD-CAPACITOR	CE 0007.7252.00	SPRAGUE	293D 105 X9 010 D2T		
C46	CE 1UF +-10% 25V EIA3528 TANTALUM SMD-CAPACITOR	CE 0007.7217.00	SPRAGUE	293D 105 X9 025 B2T		
C47	CC 0,7PF+-0,05PF 0603 SMD-CERAMIC CAPACITOR	0010.7150.00	AWX	0603 5J OR7 AAW TR		
C48	CC 0,7PF+-0,05PF 0603 SMD-CERAMIC CAPACITOR	0010.7150.00	AWX	0603 5J OR7 AAW TR		
C49	CC 1,0NF+-10%50V HDK 0603 SMD-CERAMIC-CAPACITOR	CC 0009.4938.00	MURATA	GRM39X7R***K50C500PT		
C50	CC 15PF+-1% 50VNPO 0603 SMD-CERAMIC-CAPACITOR	0009.8227.00	VITRAMON	VJ0603A *** BXAT		
C51	CC 100PF+-1% 50VNPO 0603 SMD-CERAMIC-CAPACITOR	CC 0009.4680.00	MURATA	GRM39COG***F50PT		
C52	CC 33NF+-10% 25V HDK 0603 ERAMIC CHIP CAPACITOR	1051.4697.00	AVX	CM105X7R333K25AT		
C53	CC 15PF+-1% 50VNPO 0603 SMD-CERAMIC-CAPACITOR	0009.8227.00	VITRAMON	VJ0603A *** BXAT		
C54	CC 33NF+-10% 25V HDK 0603 ERAMIC CHIP CAPACITOR	1051.4697.00	AVX	CM105X7R333K25AT		
C55	CC 100PF+-1% 50VNPO 0603 SMD-CERAMIC-CAPACITOR	CC 0009.4680.00	MURATA	GRM39COG***F50PT		
C56	CC 100PF+-1% 50VNPO 0603 SMD-CERAMIC-CAPACITOR	CC 0009.4680.00	MURATA	GRM39COG***F50PT		
C57	CC 33NF+-10% 25V HDK 0603 ERAMIC CHIP CAPACITOR	1051.4697.00	AVX	CM105X7R333K25AT		
C58	CC 100PF+-1% 50VNPO 0603 SMD-CERAMIC-CAPACITOR	CC 0009.4680.00	MURATA	GRM39COG***F50PT		
C59	CC 100PF+-1% 50VNPO 0603 SMD-CERAMIC-CAPACITOR	CC 0009.4680.00	MURATA	GRM39COG***F50PT		
C60	CE 10UF+-20%35V RUND SMD SMD-ELECTROLYTIC CAPACIT.	CE 0009.5605.00	PANASONIC	EEV HB 1V 100P		
C61	CE 10UF+-20%35V RUND SMD SMD-ELECTROLYTIC CAPACIT.	CE 0009.5605.00	PANASONIC	EEV HB 1V 100P		
C62	CC 0,7PF+-0,05PF 0603 SMD-CERAMIC CAPACITOR NICHT BESTUECKT	0010.7150.00	AWX	0603 5J OR7 AAW TR		
MENP5	413 3PUA	Äl	Datum Date	Schaltteilliste für Parts list for	Sachnummer Stock No.	Blatt-Nr. Page
	ROHDE & SCHWARZ	05	16.09.97	ED POWERMODUL	1062.7240.01 SA	1+

095.0028-0893

Kennz. Comp. No.	Benennung Designation	Sachnummer Stock No.	Hersteller Manufacturer	Bezeichnung Designation	enthalten in contained in	
C63	CC 0,7PF+-0,05PF 0603 SMD-CERAMIC CAPACITOR NICHT BESTUECKT	0010.7150.00	AWX	0603 5J OR7 AAW TR		
C64	CC 0,7PF+-0,05PF 0603 SMD-CERAMIC CAPACITOR NICHT BESTUECKT	0010.7150.00	AWX	0603 5J OR7 AAW TR		
C65	CC 0,7PF+-0,05PF 0603 SMD-CERAMIC CAPACITOR NICHT BESTUECKT	0010.7150.00	AWX	0603 5J OR7 AAW TR		
C66	CC 220PF+-1% 50VNPO 0603 SMD-CERAMIC-CAPACITOR	CC 0009.4721.00	MURATA	GRM39COG***F50PT		
D1	BL 74ACT86SC 4X 2IN-EXOR QUAD 2-INPUT EXOR GATE	BL 2005.4307.00	HARRIS	(CD74)ACT86(M)		
D2 ..5	BM SW-239 GAAS SPDTSWITCH GAAS RF-SWITCH	0853.5579.00	ANZAC	SW239		
L1	LD 2,2UH 10% 0,27A 1210 SMD-INDUCTOR	LD 0520.7870.00	SIEMENS	B82422-A1222-K100		
L2	LD 2,2UH 10% 0,27A 1210 SMD-INDUCTOR	LD 0520.7870.00	SIEMENS	B82422-A1222-K100		
L3	LD 47 NH+-10% 0,3A 0805 SMD-MULTILAYER INDUCTOR	LD 0009.6824.00	TOKO	LL2012-F47NK		
L4	LD 47 NH+-10% 0,3A 0805 SMD-MULTILAYER INDUCTOR	LD 0009.6824.00	TOKO	LL2012-F47NK		
L5	LD 1UH 10% 0,38A 1210 SMD-INDUCTOR	LD 6006.0130.00	SIEMENS	B82422-A1102-K100		
L6	LD 1UH 10% 0,38A 1210 SMD-INDUCTOR	LD 6006.0130.00	SIEMENS	B82422-A1102-K100		
L7	LD 100UH 10% 0,06A 1210 SMD-INDUCTOR	LD 0007.9261.00	SIEMENS	B82422-A1104-K100		
L8	LD 22 NH+-10% 0,3A 0603 SMD-MULTILAYER INDUCTOR	LD 0009.6730.00	TOKO	LL1608-F...K		
L9	LD 22 NH+-10% 0,3A 0603 SMD-MULTILAYER INDUCTOR	LD 0009.6730.00	TOKO	LL1608-F...K		
L10 ..21	XX ENTHALTEN IN INCLUDED IN					
L26	LD 1000UH*-20%0,3A SMD INDUCTOR	0048.4041.00	COILCRAFT	D03316P-105		
L28	LD 1000UH*-20%0,3A SMD INDUCTOR	0048.4041.00	COILCRAFT	D03316P-105		
L29 ..31	LD SP-DROSSEL 68UH 0,68A CHOKE	1081.1821.00	SUMIDA	CDR74-680		
N1	BO CLC430AJE CF OPAMP IC CURRENT FEEDBACK OPAMP	2032.2524.00	COMLINEAR	CL(C)430AJE		
N2	BO CLC430AJE CF OPAMP IC CURRENT FEEDBACK OPAMP	2032.2524.00	COMLINEAR	CL(C)430AJE		
N3	BO TLO72ACD 2XFET OPAMP OPERATIONAL AMPLIFIER	0803.1057.00	TEXAS	TL 072 ACDR		
N4	BO TLO72ACD 2XFET OPAMP OPERATIONAL AMPLIFIER	0803.1057.00	TEXAS	TL 072 ACDR		
N5	BO TLO74ACD 4XFET OPAMP OPERATIONAL AMPLIFIER	0007.7823.00	TEXAS	TLO74A(CD)		
N6	BO AD744KR FET OPAMP BIFET OPAMP	0854.1754.00	ANALOG_DEV	(AD)744KR		
P1 ..7	VL EINPRESSSTIFT L=6,8 PIN	VL 0010.7250.00	AMP	1-928776-5		
P9	VL EINPRESSSTIFT L=6,8 PIN	VL 0010.7250.00	AMP	1-928776-5		
P10	VL EINPRESSSTIFT L=6,8 PIN	VL 0010.7250.00	AMP	1-928776-5		
R1	RG 27,4 OHM+-1%TK100 1206 RESISTOR CHIP	RG 0007.5508.00	ROEDERSTEI	DC2 27,4OHM 1%TK100		
R2 ..4	RG 100R +-1% TK200 0603 SMD-RESISTOR EIA0603	RG 0009.5334.00	DRALORIC	CR 0603 100R 1%TK200		
R5	RG 82,5 OHM+-1%TK200 0603 SMD-RESISTOR EIA0603	0009.9052.00	ROEDERSTEI	D11 0603OH		
R6	RG 7K5 +-1% TK200 0603 SMD-RESISTOR EIA0603	0010.8440.00				
R7	RG 7K5 +-1% TK200 0603 SMD-RESISTOR EIA0603	0010.8440.00				
R8	RG 18R2 +-1% TK200 0603 SMD-RESISTOR EIA0603	0010.8385.00				
R9	RG 18R2 +-1% TK200 0603 SMD-RESISTOR EIA0603	0010.8385.00				
MENP5	413 3PUA	Är	Datum Date	Schaltteilliste für Parts list for	Sachnummer Stock No.	Blatt-Nr. Page
	05	16.09.97	ED POWERMODUL	1062.7240.01 SA	2+	

Für diese Unterlage behalten wir uns alle Rechte vor.

095.0026-0693

Für diese Unterlage behalten
wir uns alle Rechte vor.

Kennz. Comp. No.	Benennung Designation	Sachnummer Stock No.	Hersteller Manufacturer	Bezeichnung Designation	enthalten in contained in
R10 ..19	RG 10K +-1% TK200 0603 SMD-RESISTOR EIA0603	RG 0009.5357.00	DRALORIC	CR 0603 10K 1% TK200	
R20	RG 15K +-1% TK200 0603 SMD-RESISTOR EIA0603	0009.7043.00	DRALORIC	CR 0603 15K 1% TK200	
R21	RG 392R+-1% TK200 0603 SMD-RESISTOR EIA0603	0010.9300.00			
R22	RG 392R+-1% TK200 0603 SMD-RESISTOR EIA0603	0010.9300.00			
R23 ..28	RG 10K +-1% TK200 0603 SMD-RESISTOR EIA0603	RG 0009.5357.00	DRALORIC	CR 0603 10K 1% TK200	
R29	RG 15K +-1% TK200 0603 SMD-RESISTOR EIA0603	0009.7043.00	DRALORIC	CR 0603 15K 1% TK200	
R30	RG 68,1 OHM+-1%TK100 1206 CHIP RESISTOR	RG 0006.8849.00	ROEDERSTEI	DC2 68,10HM 1%TK100	
R31	RG 68,1 OHM+-1%TK100 1206 CHIP RESISTOR	RG 0006.8849.00	ROEDERSTEI	DC2 68,10HM 1%TK100	
R32 ..35	RG 10K +-1% TK200 0603 SMD-RESISTOR EIA0603	RG 0009.5357.00	DRALORIC	CR 0603 10K 1% TK200	
R36	RS 0,25W 2KOHM +-20% SMD POTENTIOMETER	RS 0007.9626.00	SIEMENS	S4G-2KOHM	
R37	RG 3K3 +-1% TK200 0603 SMD-RESISTOR EIA0603	0009.7014.00	ROEDERSTEI	D11 0603OH	
R38	RG 3K3 +-1% TK200 0603 SMD-RESISTOR EIA0603	0009.7014.00	ROEDERSTEI	D11 0603OH	
R39	RG 56,2 OHM+-1%TK100 1206 CHIP RESISTOR	RG 0006.8826.00	ROEDERSTEI	DC2 56,20HM 1%TK100	
R40	RG 56,2 OHM+-1%TK100 1206 CHIP RESISTOR	RG 0006.8826.00	ROEDERSTEI	DC2 56,20HM 1%TK100	
R41	RG 27,4 OHM+-1%TK100 1206 RESISTOR CHIP	RG 0007.5508.00	ROEDERSTEI	DC2 27,40HM 1%TK100	
R42	RG 39K2 +-1% TK200 0603 SMD-REGISTER	0010.9823.00			
R43	RG 1K0 +-1% TK200 0603 SMD-RESISTOR EIA0603	RG 0009.5340.00	DRALORIC	CR 0603 1K 1% TK200	
R44	RG 1K0 +-1% TK200 0603 SMD-RESISTOR EIA0603	RG 0009.5340.00	DRALORIC	CR 0603 1K 1% TK200	
R45	RG 470R +-1% TK200 0603 SMD-RESISTOR EIA0603	0009.6976.00	ROEDERSTEI	D11 0603OH	
R46	RG 1K5 +-1% TK200 0603 SMD-RESISTOR EIA0603	0009.6999.00	ROEDERSTEI	D11 0603OH	
R47	RG 330R +-1% TK200 0603 SMD-RESISTOR EIA0603	0009.6960.00	DRALORIC	CR 06030	
R48	RG 270R +-1% TK200 0603 SMD-RESISTOR EIA0603	0010.9581.00			
R49	RG 330R +-1% TK200 0603 SMD-RESISTOR EIA0603	0009.6960.00	DRALORIC	CR 06030	
R50	RG 270R +-1% TK200 0603 SMD-RESISTOR EIA0603	0010.9581.00			
R51	RG 110 OHM+-1%TK200 0603 SMD-RESISTOR EIA0603	0009.9481.00	ROEDERSTEI	D11 0603OH	
R52	RG 110 OHM+-1%TK200 0603 SMD-RESISTOR EIA0603	0009.9481.00	ROEDERSTEI	D11 0603OH	
R53	RG 392R+-1% TK200 0603 SMD-RESISTOR EIA0603	0010.9300.00			
R54	RG 470R +-1% TK200 0603 SMD-RESISTOR EIA0603	0009.6976.00	ROEDERSTEI	D11 0603OH	
R55	RG 1K21 +-1% TK200 0603 SMD-REGISTER	0010.9817.00			
R56	RG 10R +-1% TK200 0603 SMD-RESISTOR EIA0603	RG 0009.5328.00	DRALORIC	CR 0603	
R57	RG 10R +-1% TK200 0603 SMD-RESISTOR EIA0603	RG 0009.5328.00	DRALORIC	CR 0603	
R58 ..63	RG 24,3 OHM+-1%TK100 1206 RESISTOR CHIP	RG 0007.5495.00	ROEDERSTEI	DC2 24,30HM 1%TK100	
R64	RG 0-OHM WIDERSTAND-CHIP RESISTOR CHIP 0-OHM NICHT BESTUECKT	RG 0007.5108.00	DRALORIC	CR 1206	
R65	RG 0-OHM WIDERSTAND-CHIP RESISTOR CHIP 0-OHM NICHT BESTUECKT	RG 0007.5108.00	DRALORIC	CR 1206	
R66	RG 0-OHM WIDERSTAND-CHIP RESISTOR CHIP 0-OHM	RG 0007.5108.00	DRALORIC	CR 1206	
R67	RG 2,0 OHM+-1%TK100 1206 CHIP-RESISTOR	RG 0007.8336.00	PHILIPS	RC 02	
R68	RG 2,0 OHM+-1%TK100 1206 CHIP-RESISTOR	RG 0007.8336.00	PHILIPS	RC 02	
R69	RG 0-OHM WIDERSTAND-CHIP RESISTOR CHIP 0-OHM	RG 0007.5108.00	DRALORIC	CR 1206	

MENP5

413 3PUA

Äi

Datum

16.09.97

Schaltteilleiste für
Parts list for

ED POWERMODUL

Sachnummer
Stock No.

1062.7240.01 SA

Blatt-Nr.
Page

3+



ROHDE & SCHWARZ

095.0026-0693

Kennz. Comp. No.	Benennung Designation	Sachnummer Stock No.	Hersteller Manufacturer	Bezeichnung Designation	enthalten in contained in
R70	RG 0-OHM WIDERSTAND-CHIP RESISTOR CHIP 0-OHM	RG 0007.5108.00	DRALORIC	CR 1206	
R71	RG 1K0 +-1% TK200 0603 SMD-RESISTOR EIA0603	RG 0009.5340.00	DRALORIC	CR 0603 1K 1% TK200	
R72	RG 0-OHM WIDERSTAND-CHIP RESISTOR CHIP 0-OHM	RG 0007.5108.00	DRALORIC	CR 1206	
R73	RG 10K +-1% TK200 0603 SMD-RESISTOR EIA0603 NICHT BESTUECKT	RG 0009.5357.00	DRALORIC	CR 0603 10K 1% TK200	
R74	RG 1M0 +-1% TK200 0603 SMD-RESISTOR EIA0603	RG 0009.5370.00	DRALORIC	CR 0603 1M 1% TK200	
R76	RG 560R +-1% TK200 0603 SMD-RESISTOR EIA0603	0009.9630.00	DRALORIC	CR 06030
R77	RG 560R +-1% TK200 0603 SMD-RESISTOR EIA0603	0009.9630.00	DRALORIC	CR 06030
R78	RG 680K +-1% TK200 0603 SMD-RESISTOR EIA0603	0009.7137.00	ROEDERSTEI	D11 06030H
R79	RG 680K +-1% TK200 0603 SMD-RESISTOR EIA0603	0009.7137.00	ROEDERSTEI	D11 06030H
R80	RG 39R2 +-1% TK200 0603 SMD-RESISTOR EIA0603	0010.9400.00			
R81	RG 39R2 +-1% TK200 0603 SMD-RESISTOR EIA0603	0010.9400.00			
R82	RG 560R +-1% TK200 0603 SMD-RESISTOR EIA0603	0009.9630.00	DRALORIC	CR 06030
R83	RG 560R +-1% TK200 0603 SMD-RESISTOR EIA0603	0009.9630.00	DRALORIC	CR 06030
R84	RG 4R75 +-1% TK200 0603 SMD-RESISTOR EIA0603	0010.8379.00			
R85	RG 1K0 +-1% TK200 0603 SMD-RESISTOR EIA0603	RG 0009.5340.00	DRALORIC	CR 0603 1K 1% TK200	
R86	RG 4R75 +-1% TK200 0603 SMD-RESISTOR EIA0603	0010.8379.00			
R87	RG 1K0 +-1% TK200 0603 SMD-RESISTOR EIA0603	RG 0009.5340.00	DRALORIC	CR 0603 1K 1% TK200	
R88	RG 22K +-1% TK200 0603 SMD-RESISTOR EIA0603	0009.7050.00	ROEDERSTEI	D11 06030H
R89	RG 2K0 +-1% TK200 0603 SMD RESISTOR	1097.6328.00			
R90	RG 2K0 +-1% TK200 0603 SMD RESISTOR	1097.6328.00			
R91	RG 51,0 OHM+-1%TK200 0603 SMD-RESISTOR EIA0603	0009.9030.00	ROEDERSTEI	D11 06030H
R94	RG 150R +-1% TK200 0603 SMD-RESISTOR EIA0603	0009.6947.00	ROEDERSTEI	D11 06030H
R95	RG 150R +-1% TK200 0603 SMD-RESISTOR EIA0603	0009.6947.00	ROEDERSTEI	D11 06030H
R98	RG 51,0 OHM+-1%TK200 0603 SMD-RESISTOR EIA0603	0009.9030.00	ROEDERSTEI	D11 06030H
R99	RG 51,0 OHM+-1%TK200 0603 SMD-RESISTOR EIA0603	0009.9030.00	ROEDERSTEI	D11 06030H
R104	RG 47R +-1% TK200 0603 SMD-RESISTOR EIA0603	0009.6924.00	ROEDERSTEI	D11 06030H
R105	RG 47R +-1% TK200 0603 SMD-RESISTOR EIA0603	0009.6924.00	ROEDERSTEI	D11 06030H
R106	RG 3K92 +-1% TK200 0603 SMD-RESISTOR EIA0603	0010.8427.00			
R108	RG 3K92 +-1% TK200 0603 SMD-RESISTOR EIA0603	0010.8427.00			
R109	RG 100K +-1% TK200 0603 SMD RESISTOR	RG 0009.5363.00	DRALORIC	CR 0603 100K 1%TK200	
R112	RG 357R +-1% TK200 0603 SMD RESISTOR	1097.6405.00			
R113	RG 357R +-1% TK200 0603 SMD RESISTOR	1097.6405.00			
R114	RG 357R +-1% TK200 0603 SMD RESISTOR	1097.6405.00			
R115	RG 3K92 +-1% TK200 0603 SMD-RESISTOR EIA0603	0010.8427.00			
R116	RG 3K92 +-1% TK200 0603 SMD-RESISTOR EIA0603	0010.8427.00			
R117	RG 56R +-1% TK200 0603 SMD-RESISTOR EIA0603	0009.9646.00	ROEDERSTEI	D11 06030H
R118	RG 56R +-1% TK200 0603 SMD-RESISTOR EIA0603	0009.9646.00	ROEDERSTEI	D11 06030H
R119	RG 562 OHM+-1%TK100 1206 CHIP RESISTOR	RG 0006.9068.00	ROEDERSTEI	DC2 562OHM 1%TK100	
R120	RG 562 OHM+-1%TK100 1206 CHIP RESISTOR NICHT BESTUECKT"	RG 0006.9068.00	ROEDERSTEI	DC2 562OHM 1%TK100	
R121	RG 121 OHM+-1%TK100 1206 CHIP RESISTOR	RG 0006.8903.00	ROEDERSTEI	DC2 121OHM 1%TK100	
R122	RG 121 OHM+-1%TK100 1206 CHIP RESISTOR NICHT BESTUECKT"	RG 0006.8903.00	ROEDERSTEI	DC2 121OHM 1%TK100	
R123	RG 39R2 +-1% TK200 0603 SMD-RESISTOR EIA0603	0010.9400.00			

Für diese Unterlage behalten wir uns alle Rechte vor.

MENP5	413 3PUA	Ät	Datum Date	Schaltteilliste für Parts list for	Sachnummer Stock No.	Blatt-Nr. Page
	ROHDE & SCHWARZ	05	16.09.97	ED POWERMODUL	1062.7240.01 SA	4+

095.0026-0693

Für diese Unterlage behalten wir uns alle Rechte vor.

Kennz. Comp. No.	Benennung Designation	Sachnummer Stock No.	Hersteller Manufacturer	Bezeichnung Designation	enthalten in contained in
R124	RG 0-OHM WIDERSTAND 0603 O-OHM RESISTOR EIA0603	0009.9369.00	PHILIPS_CO	RC21 0 OHM	
R125	RG 0-OHM WIDERSTAND 0603 O-OHM RESISTOR EIA0603 NICHT BESTUECKT	0009.9369.00	PHILIPS_CO	RC21 0 OHM	
R126	RG 150K +-1% TK200 0603 SMD-RESISTOR EIA0603	0009.7095.00	ROEDERSTEI	D11 0603OH	
R127	RG 39K2 +-1% TK200 0603 SMD-REGISTER	0010.9823.00			
R128 ..133	RG 39,2 OHM+-1%TK100 1206 RESISTOR CHIP	RG 0007.5543.00	ROEDERSTEI	DC2 39,2OHM 1%TK100	
R134 ..143	RG 1MO +-1% TK200 0603 SMD-RESISTOR EIA0603	RG 0009.5370.00	DRALORIC	CR 0603 1M 1% TK200	
R144	RG 39R2 +-1% TK200 0603 SMD-RESISTOR EIA0603	0010.9400.00			
R150	RL 0,60W 8,25KOHM+-1%TK50 RESISTOR	RL 0083.1239.00	RESISTA	MK2	
V1	AE BZV55/C4V7 0.5W ZDI ZENER DIODE	AE 0006.9822.00	PHILIPS	BZV55B4V7	
V2	AE BZV55/C4V7 0.5W ZDI ZENER DIODE	AE 0006.9822.00	PHILIPS	BZV55B4V7	
V3	AE 1N827 6,2V REF DI REFERENCE DIODE	AE 0418.0029.00	COMPENSATE	1N827(A)	
V4	AK BSP31 P 60V 1A TRAN TRANSISTOR	1085.1755.00	PHILIPS_SE	BSP31	
V5	AK BSP31 P 60V 1A TRAN TRANSISTOR	1085.1755.00	PHILIPS_SE	BSP31	
V6 ..8	AD BAS32 75V UDI DIODE	AD 0006.7288.00	PHILIPS	BAS32 (L)	
V9	AD BAV99 70V DUO UDI DIODE	AD 0911.0092.00	VALVO	BAV99	
V10	AD BAV99 70V DUO UDI DIODE	AD 0911.0092.00	VALVO	BAV99	
V11	AM SHF0186 SELEC.9V GAASF TRANSISTOR GAASFET	1062.9308.00			
V12	AM SHF0186 SELEC.9V GAASF TRANSISTOR GAASFET	1062.9308.00			
V13	AE BAT62 1+1 40V SCHOTTKY DIODE PAIR	1051.4045.00	SIEMENS	BAT62 (62)	
V14	AD BAV99 70V DUO UDI DIODE	AD 0911.0092.00	VALVO	BAV99	
V15	AE HSMS2810 SCHOTTKY DIODE	0520.7340.00	HEWLETT_PA	HSMS2810	
V16	AE HSMS2810 SCHOTTKY DIODE	0520.7340.00	HEWLETT_PA	HSMS2810	
V17	NICHT BESTUECKT AE HSMS2810 SCHOTTKY DIODE	0520.7340.00	HEWLETT_PA	HSMS2810	
V18	AE HSMS2810 SCHOTTKY DIODE	0520.7340.00	HEWLETT_PA	HSMS2810	
V19	NICHT BESTUECKT AE HSMS2810 SCHOTTKY DIODE	0520.7340.00	HEWLETT_PA	HSMS2810	
V20	AE HSMS2810 SCHOTTKY DIODE	0520.7340.00	HEWLETT_PA	HSMS2810	
V21	AE BZV55/C8V2 0,5W ZDI ZENER DIODE	AE 0006.9874.00	PHILIPS	BZV55B8V2	
V22	AE BZV55/C8V2 0,5W ZDI ZENER DIODE	AE 0006.9874.00	PHILIPS	BZV55B8V2	
V23	AE HSMS2825 1+1 SCHOTTKY SCHOTTKY DIODE PAIR	1010.6214.00	HEWLETT_PA	HSMS2825 L31	
V24	AE HSMS2825 1+1 SCHOTTKY SCHOTTKY DIODE PAIR	1010.6214.00	HEWLETT_PA	HSMS2825 L31	
V25	AD BAV99 70V DUO UDI DIODE	AD 0911.0092.00	VALVO	BAV99	
V26	AE BZV55/C5V6 0.5W ZDI ZENER DIODE NICHT BESTUECKT" NOT FITTED"	AE 0006.9845.00	PHILIPS	BZV55B5V6	
V27	AD BAS32 75V UDI DIODE NICHT BESTUECKT" NOT FITTED"	AD 0006.7288.00	PHILIPS	BAS32 (L)	
X1	FP STECKERLEISTE 16P.WIN CONNECTOR	FP 0738.5341.00	SIEMENS	V23535-A2210-162	

095.0028-0893

MENP5	413 3PUA	ÄI	Datum Date	Schaltteilliste für Parts list for	Sachnummer Stock No.	Blatt-Nr. Page
		05	16.09.97	ED POWERMODUL	1062.7240.01 SA	5+

Kanz. Comp. No.	Benennung Designation	Sachnummer Stock No.	Hersteller Manufacturer	Bezeichnung Designation	enthalten in contained in
X2	FJ EINLOETBUCHSE SMA CONNECTOR	1085.1726.00	SUHNER	82SMA-S-50-0-45/111	
X3	FJ EINLOETBUCHSE MMCX CONNECTOR	1085.1532.00	SUHNER	82MMCXS50-0-2/111KE	
X4	FJ EINLOETBUCHSE SMA CONNECTOR	1085.1726.00	SUHNER	82SMA-S-50-0-45/111	
X5	FJ EINLOETBUCHSE MMCX CONNECTOR	1085.1532.00	SUHNER	82MMCXS50-0-2/111KE	
X6	FJ EINLOETBUCHSE MMCX SMD CONNECTOR NICHT BESTUECKT	1085.2045.00	IMS	1863.09.2620.001(003	
Z1 ..6	LD SMD-T-FILTER 3,3NF SMD-FILTER	1039.1362.00	MURATA	NFM61R20T332T1	

MENP5	413 3PUA	Äi	Datum Date	Schaltteilliste für Parts list for	Sachnummer Stock No.	Blatt-Nr. Page
	ROHDE & SCHWARZ	05	16.09.97	ED POWERMODUL	1062.7240.01 SA	6-

XY-Liste

XY List

Erklärung der Spaltenbezeichnungen:

- Part:** Bauelement-Kennzeichen.
- Side: ...-** Leiterplatten-Seite, auf der sich das Bauelement befindet.
- X/Y:** Koordinaten (Millimeter) des Bauelementes auf der Leiterplatte bezogen auf den Nullpunkt.
- SQR, PG:** Planquadrat und Seite des Schaltbildes für das jeweilige Bauelement.

Explanation of column designations:

- Part:** Identification of instrument part.
- Side:** Side of the PC board on which instrument part is positioned.
- X/Y:** Coordinates (millimeter) of the component on the PC board in reference to zero point.
- SQR, PG:** Square and page of the diagram for the respective instrument part.

Service-Relevante Bauteile / Service-Relevant Components																	
Part	Side	X	Y	Sqr	Pg	Part	Side	X	Y	Sqr	Pg	Part	Side	X	Y	Sqr	Pg
R36	B	104	61	2D	4												

Nicht-Service-Relevante Bauteile / Non-Service-Relevant Components																	
Part	Side	X	Y	Sqr	Pg	Part	Side	X	Y	Sqr	Pg	Part	Side	X	Y	Sqr	Pg
C1	B	61	12	4D	2	C47	B	64	15	4E	2	L30	B	14	61	1C	1
C2	B	61	32	4D	3	C48	B	64	29	4E	3	L31	B	14	50	1D	1
C3	A	11	10	6D	1	C49	B	108	51	3D	4	N1	A	23	20	6B	1
C4	A	23	11	6D	1	C50	B	80	15	6D	2	N1	A	23	20	7D	1
C5	A	18	22	6D	1	C51	A	85	47	8A	2	N2	A	14	20	6C	1
C6	A	22	22	7D	1	C52	A	79	59	7A	2	N2	A	14	20	6D	1
C7	A	81	57	7B	2	C53	B	80	30	6D	3	N3	A	83	58	4E	2
C8	A	87	61	4F	2	C54	A	53	59	7B	3	N3	A	83	58	7B	2
C9	A	90	54	4E	2	C55	A	59	48	8B	3	N3	A	83	58	8B	2
C10	A	47	11	4D	2	C56	B	94	34	5B	4	N4	A	58	58	4E	3
C11	A	47	13	3D	2	C57	B	100	41	3B	4	N4	A	58	58	7B	3
C12	A	38	11	2D	2	C58	B	71	14	5E	2	N4	A	58	58	8B	3
C13	A	38	17	2D	2	C59	B	71	29	5E	3	N5	B	102	50	2D	4
C14	A	55	57	7C	3	C60	B	65	45	4A	2	N5	B	102	50	3E	4
C15	A	62	61	4F	3	C61	B	65	51	4A	3	N5	B	102	50	5D	4
C16	A	65	54	4E	3	D1	A	31	26	4C	1	N5	B	102	50	7C	4
C17	A	38	34	2D	3	D1	A	31	26	5D	1	N5	B	102	50	7D	4
C18	A	38	28	2D	3	D1	A	31	26	6B	1	N6	B	104	43	2C	4
C19	A	47	30	3D	3	D1	A	31	26	6C	1	N6	B	104	43	4E	4
C20	A	47	28	4D	3	D1	A	31	26	8D	1	P1	B	31	53	2D	1
C21	B	95	55	6D	4	D2	B	35	11	1D	2	P2	B	29	53	2D	1
C22	B	95	53	7C	4	D3	B	52	15	4D	2	P3	B	97	60	7D	4
C23	B	71	64	2E	4	D4	B	52	32	4E	3	P4	B	91	51	7C	4
C24	B	71	55	2F	4	D5	B	35	28	2E	3	P5	B	111	58	3C	4
C25	A	103	54	3E	4	L1	B	87	8	6C	2	P6	B	100	45	2C	4
C26	A	97	54	3F	4	L2	B	87	36	6C	3	P7	B	100	48	2C	4
C27	A	109	43	4E	4	L3	B	81	11	6C	2	P9	B	91	48	7C	4
C28	A	104	41	4F	4	L4	B	81	33	6D	3	P10	B	97	63	7D	4
C29	B	105	52	2E	4	L5	B	66	61	2E	4	R1	B	103	34	5A	4
C30	B	30	56	2D	1	L6	B	66	58	2F	4	R2	A	79	51	5B	2
C31	B	30	49	2D	1	L7	B	93	41	5B	4	R3	A	53	51	5B	3
C32	A	68	51	5A	2	L8	B	81	8	6C	2	R4	B	97	46	3B	4
C33	A	43	51	5A	3	L9	B	81	37	6C	3	R5	B	96	38	4B	4
C34	B	96	44	4B	4	L10	B	64	15	4D	2	R6	A	49	36	3C	3
C35	A	16	32	3B	1	L11	B	78	12	5D	2	R7	A	47	35	3D	3
C36	B	23	47	2C	1	L12	B	89	14	6D	2	R8	B	80	16	6D	2
C37	A	29	24	6B	1	L13	B	79	15	6D	2	R9	B	80	28	6D	3
C38	A	26	24	5C	1	L14	B	93	9	6B	2	R10	B	20	30	4B	1
C39	A	35	22	5D	1	L15	B	63	29	4E	3	R11	A	21	30	4C	1
C40	B	101	41	3B	4	L16	B	81	29	6D	3	R12	A	31	22	6B	1
C41	B	74	11	5D	2	L17	B	92	35	6C	3	R13	A	24	24	6C	1
C42	B	89	15	7D	2	L19	B	78	32	5D	3	R14	A	26	35	8D	1
C43	B	56	15	4D	2	L20	B	89	29	6D	3	R15	A	33	24	7D	1
C44	B	56	29	4E	3	L26	B	81	58	6B	2	R16	A	81	63	7B	2
C45	B	74	33	5D	3	L28	B	55	57	6B	3	R17	A	81	65	7B	2
C46	B	89	29	7D	3	L29	B	24	68	1C	1	R18	A	85	50	8B	2

ROHDE & SCHWARZ	ãI	Datum Date	XY-Liste für XY-list for	Sach-Nummer Stock-Nr	Blatt Page
	02	21.04.97	ED POWERMODUL	1062.7240.01 XY	1+



Part	Side	X	Y	Sqr	Pg	Part	Side	X	Y	Sqr	Pg	Part	Side	X	Y	Sqr	Pg
R19	A	88	50	8B	2	R68	B	43	55	3D	1	R118	B	101	65	2D	4
R20	A	77	57	7B	2	R69	B	43	49	3D	1	R119	B	18	31	3B	1
R21	B	111	45	3C	4	R70	B	43	46	3D	1	R120	B	15	31	3B	1
R22	B	108	49	3D	4	R71	B	41	53	3D	1	R121	A	9	29	3B	1
R23	B	62	14	4D	2	R72	B	43	44	3D	1	R122	A	9	32	3B	1
R24	B	62	31	4D	3	R73	B	33	53	1D	1	R123	A	30	14	3B	1
R25	A	58	64	7B	3	R74	A	81	59	7B	2	R124	B	107	37	6A	4
R26	A	58	62	7B	3	R75	A	55	59	7B	3	R125	B	105	36	6A	4
R27	A	59	50	8B	3	R76	B	102	47	2B	4	V1	A	57	10	4D	2
R28	A	63	50	8B	3	R77	B	21	31	4C	1	V2	A	57	35	4D	3
R29	A	51	57	7B	3	R78	B	102	45	2B	4	V3	B	98	66	6D	4
R30	A	11	23	6E	1	R79	B	96	48	3B	4	V4	A	73	58	5B	2
R31	A	13	23	6E	1	R80	A	80	63	6B	2	V5	A	48	58	5B	3
R32	B	106	59	5D	4	R81	A	54	64	6B	3	V6	B	103	60	5D	4
R33	B	95	58	6D	4	R82	A	21	17	7B	1	V7	B	105	55	3D	4
R34	B	94	57	6D	4	R83	A	11	17	7C	1	V8	B	108	47	2B	4
R35	B	95	51	7C	4	R85	A	81	51	5B	2	V9	A	78	49	5B	2
R37	B	106	51	2D	4	R87	A	55	51	5B	3	V10	A	53	49	5B	3
R38	B	106	45	2C	4	R88	B	105	57	5D	4	V11	B	74	15	5D	2
R39	B	95	30	5A	4	R89	A	38	37	5B	1	V12	B	74	29	5E	3
R40	B	95	32	5A	4	R90	A	28	36	5C	1	V13	B	96	40	3B	4
R41	B	101	33	5A	4	R91	B	26	15	3A	1	V13	B	96	40	4B	4
R42	A	79	57	6A	4	R92	B	26	18	3A	1	V15	A	40	24	5B	1
R43	A	81	67	6B	2	R93	B	37	18	2E	2	V16	A	38	22	5B	1
R44	A	54	62	6B	3	R94	B	49	8	3E	2	V17	A	32	10	7B	1
R45	B	112	53	3C	4	R95	A	45	9	3C	2	V18	A	15	37	5C	1
R46	B	95	60	6C	4	R96	A	45	15	3C	2	V19	A	23	35	5C	1
R47	B	78	12	5D	2	R97	A	34	11	2C	2	V20	A	18	10	7C	1
R48	B	86	11	5C	2	R98	A	34	17	2C	2	V21	A	27	7	7B	1
R49	B	78	32	5D	3	R99	A	34	34	2D	3	V22	A	14	7	7C	1
R50	B	86	34	5C	3	R100	A	34	28	2D	3	V23	B	25	29	4B	1
R51	A	79	43	5A	2	R101	A	45	32	3D	3	V23	B	25	29	4C	1
R52	A	53	43	5A	3	R102	A	45	26	3D	3	V24	B	113	48	3C	4
R53	B	108	58	6D	4	R103	B	49	25	3E	3	V24	B	113	48	3D	4
R54	B	110	56	3D	4	R104	B	37	35	2E	3	X1	B	9	48	1E	1
R55	B	100	38	3B	4	R105	B	110	37	6A	4	X2	B	9	22	3A	1
R56	B	71	15	5D	2	R106	B	101	42	2B	4	X3	B	6	35	3C	1
R57	B	71	31	5E	3	R107	B	94	38	5B	4	X4	B	112	15	7D	2
R58	A	68	43	6A	2	R108	B	90	42	4B	4	X5	B	115	55	4D	4
R59	A	70	43	6A	2	R109	A	63	9	4D	2	X6	B	107	31	7A	4
R60	A	73	43	6A	2	R110	A	64	36	4D	3	Z1	B	20	43	2C	1
R61	A	42	43	6A	3	R111	B	102	62	2E	4	Z2	B	34	55	2C	1
R62	A	45	43	6A	3	R112	B	100	67	2D	4	Z3	B	34	45	2D	1
R63	A	47	43	6A	3	R113	A	20	24	6B	1	Z4	B	34	50	2D	1
R64	A	19	45	1E	1	R114	A	15	24	6C	1	Z5	B	25	43	2E	1
R65	A	31	57	1E	1	R115	B	105	49	2D	4	Z6	B	34	60	2E	1
R66	B	17	36	3C	1	R116	B	107	45	2C	4						
R67	B	43	58	3C	1	R117	B	101	64	2E	4						

ROHDE & SCHWARZ	áI	Datum Date	XY-Liste f#r XY-list for	Sach-Nummer Stock-Nr	Blatt Page
		02 21.04.97	ED POWERMODUL	1062.7240.01 XY	2-





ROHDE & SCHWARZ

Stromläufe
Bestückungspläne
Circuit diagrams
Components plans
Schémas de circuit
Plans des composants

A
B
C
D
E
F

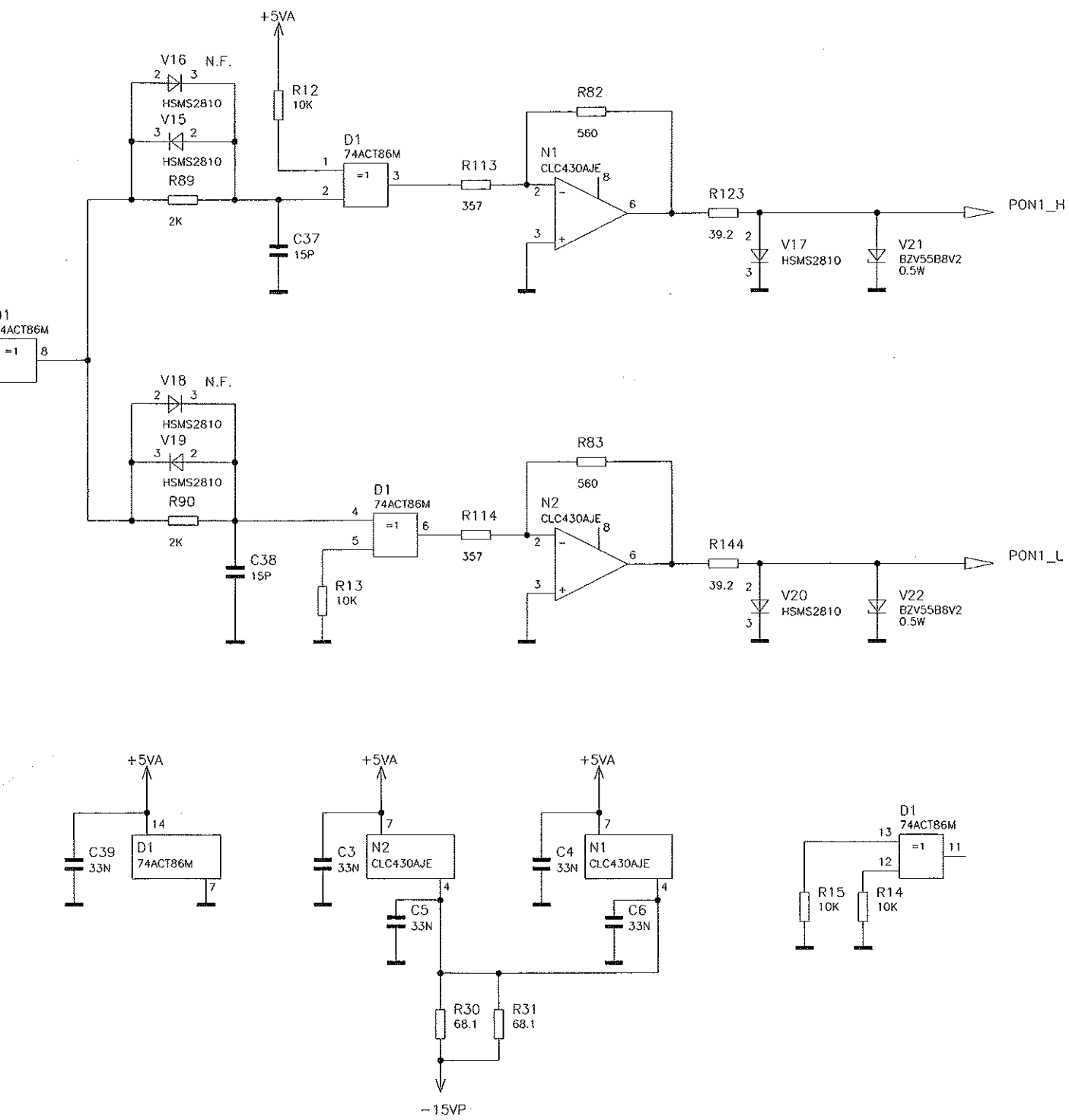

02.03			EI	MENP	DATUM	NAME	BENENNUNG		
				BEARB.		EI	POWERMODUL		
				GEPR.		EI			
				NORM					
				PLOTT	23.9.97	IMMERZ	TOP/TOP.1		
ROHDE&SCHWARZ							ZEICHN.-NR.	BLATT-NR.	
							1062.7240.01 S	1 +	
AEND. IND.	AENDERUNGS-MITTEILUNG	DATUM	NAME	ZU GERAET	SMY44	REG.I.V.	1062.5502	ERSTE Z.	0000.0000.00

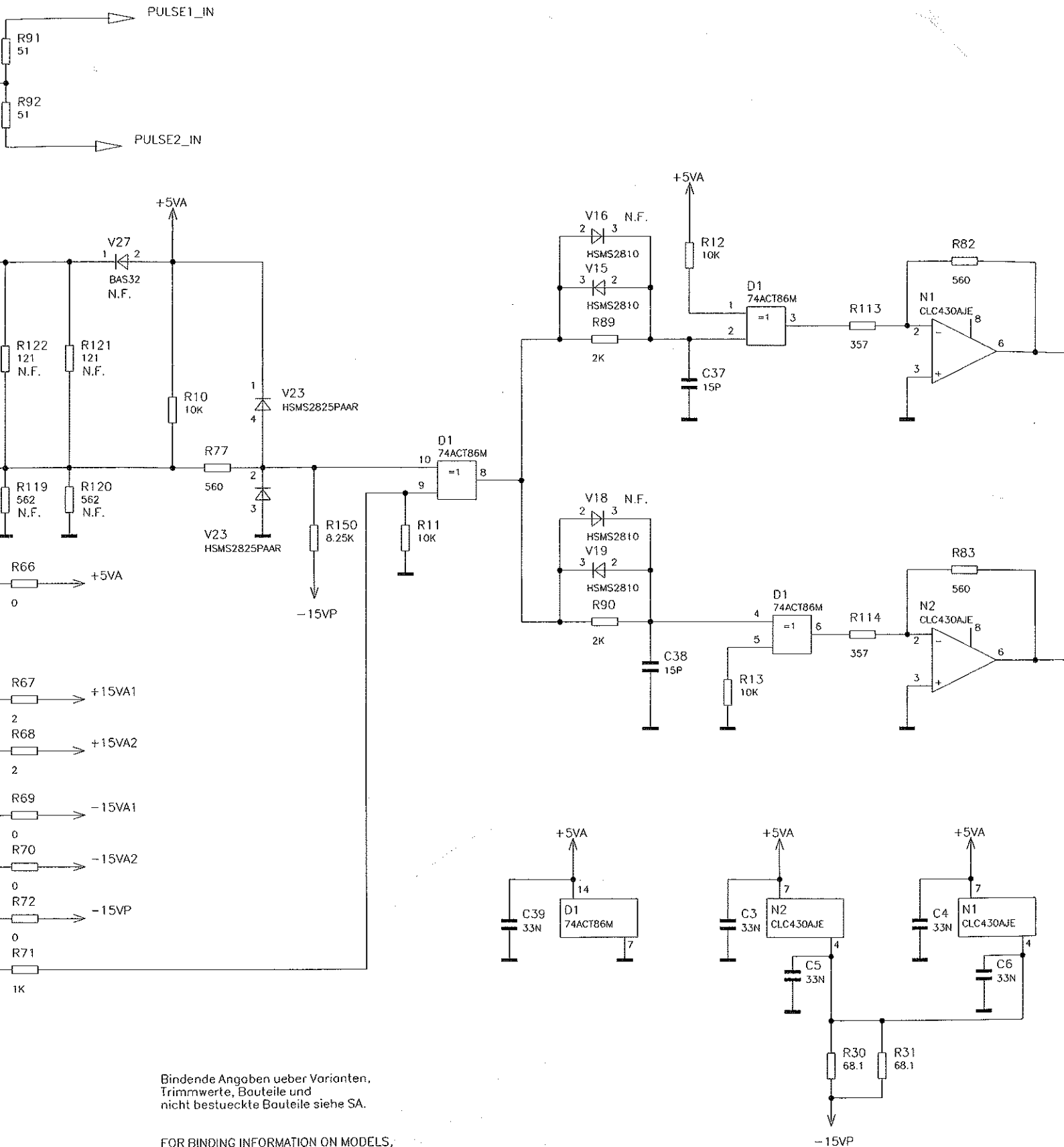

Bindende Angaben ueber Varianten,
Trimmwerte, Bauteile und
nicht bestueckte Bauteile siehe SA.

FOR BINDING INFORMATION ON MODELS,
TRIMMING AND COMPONENTS VALUES AND
NONFITTED COMPONENTS SEE PARTS LIST

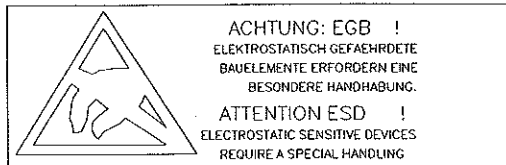

02.03			EI	MENP	DATUM	NAME	BENENNUNG
				BEARB.		EI	POWER
				GEPR.		EI	
				NORM			TOP/TOP.
				PLOTT	23.9.97	IMMERZ	ZEICHNUNG
ROHDE & SCHWARZ							
AEND. IND.	AENDERUNGS-MITTEILUNG	DATUM	NAME	ZU GERAET	SMY44		REG.I.V.

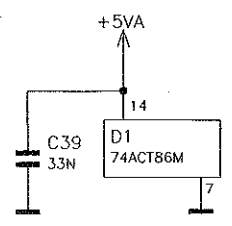
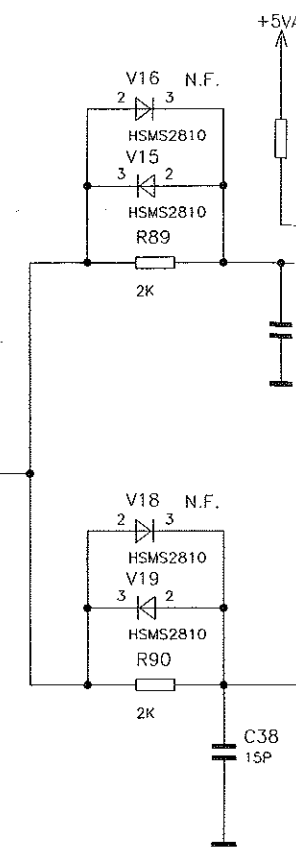
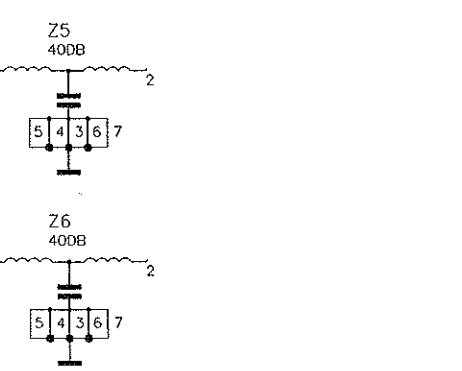
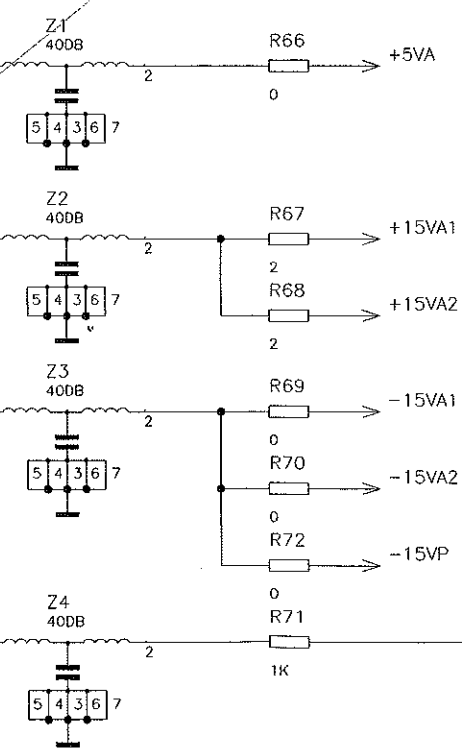
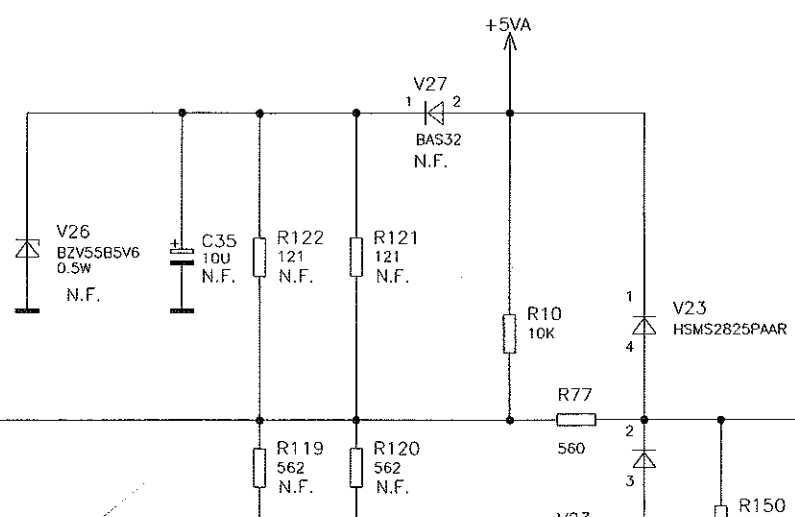
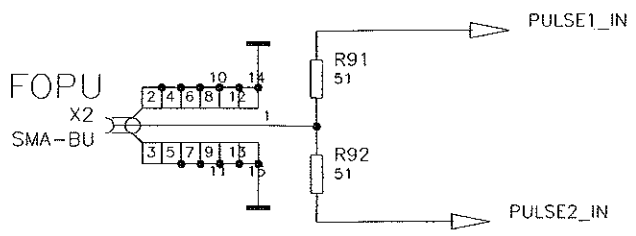

Bindende Angaben ueber Varianten, Trimmwerte, Bauteile und nicht bestueckte Bauteile siehe SA.

FOR BINDING INFORMATION ON MODELS, TRIMMING AND COMPONENTS VALUES AND NONFITTED COMPONENTS SEE PARTS LIST

ACHTUNG: EGB !
ELEKTROSTATISCH GEFAEHRDETE BAUELEMENTE ERFORDERN EINE BESONDERE HANDHABUNG.
ATTENTION ESD !
ELECTROSTATIC SENSITIVE DEVICES REQUIRE A SPECIAL HANDLING

02.03		
AEND. IND.	AENDERUNGS-MITTEILUNG	D

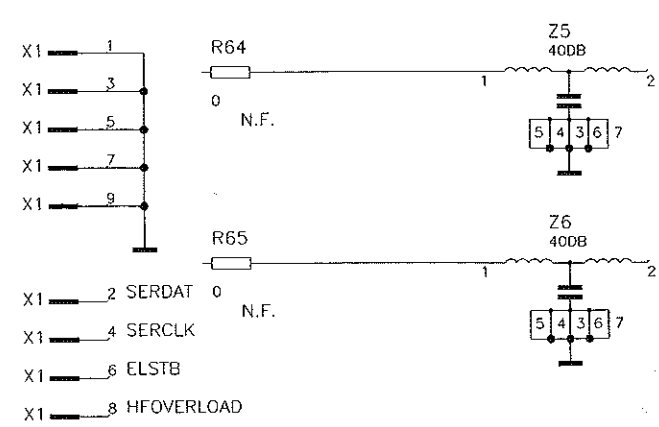
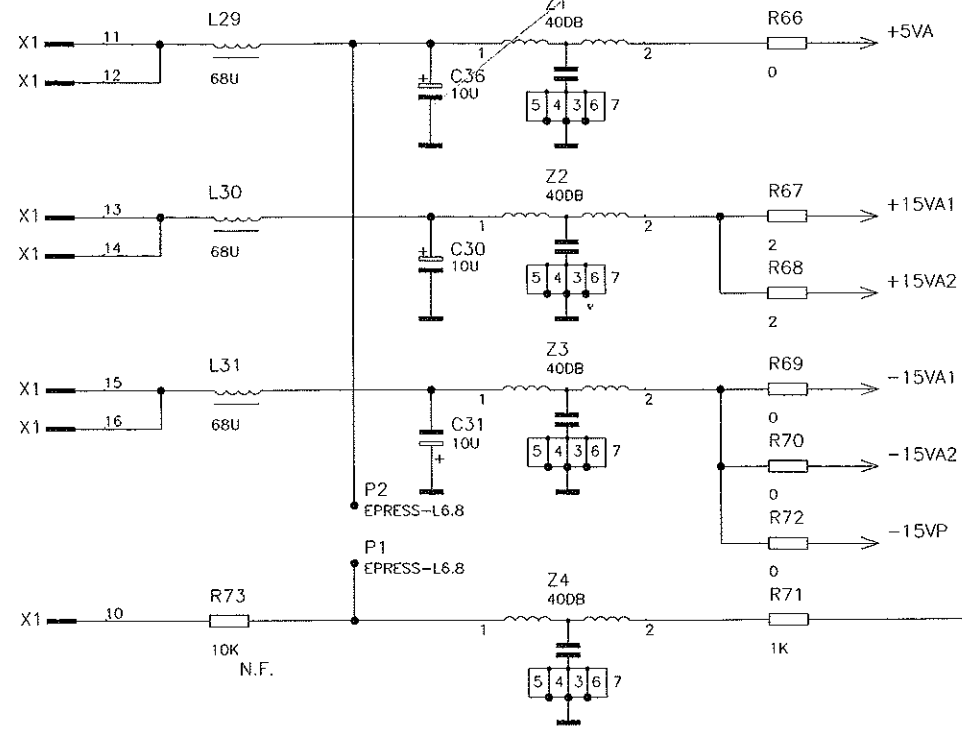
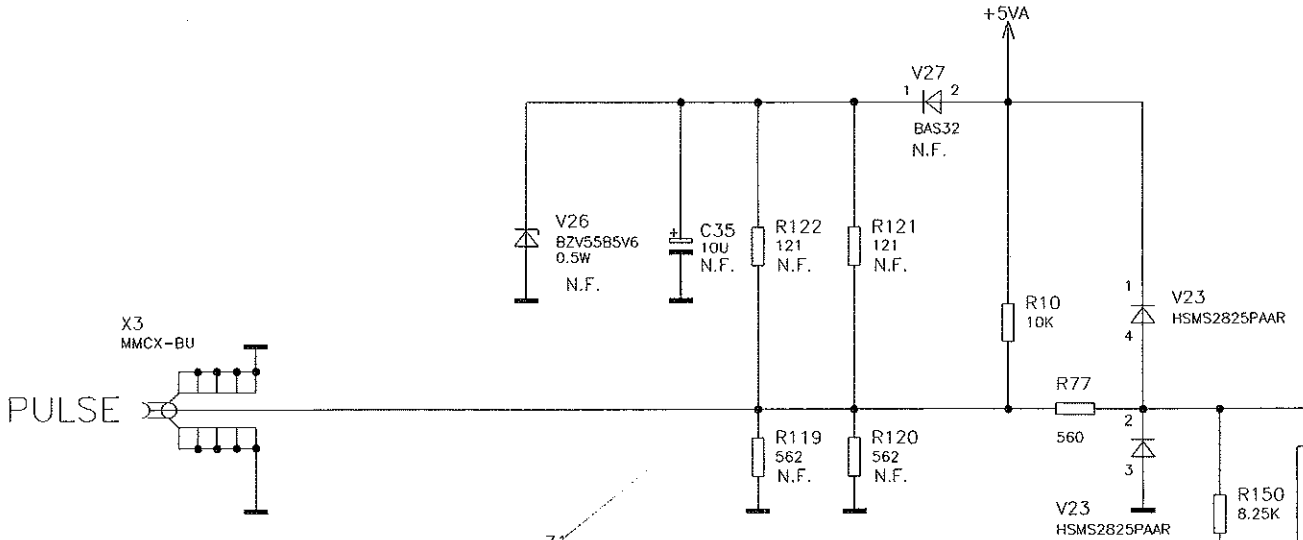
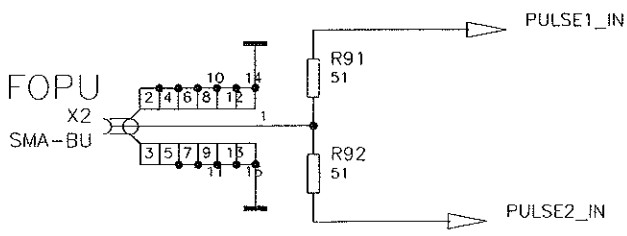

Bindende Angaben ueber Varianten, Trimmwerte, Bauteile und nicht bestueckte Bauteile siehe SA.

FOR BINDING INFORMATION ON MODELS, TRIMMING AND COMPONENTS VALUES AND NONFITTED COMPONENTS SEE PARTS LIST

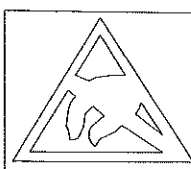

ACHTUNG: EGB !
ELEKTROSTATISCH GEFAEHRDETE
BAUELEMENTE ERFORDERN EINE
BESONDERE HANDHABUNG.
ATTENTION ESD !
ELECTROSTATIC SENSITIVE DEVICES
REQUIRE A SPECIAL HANDLING

BEHALTEN WIR UNS ALLE RECHTE VOR
FUER DIESE UNTERLAGE

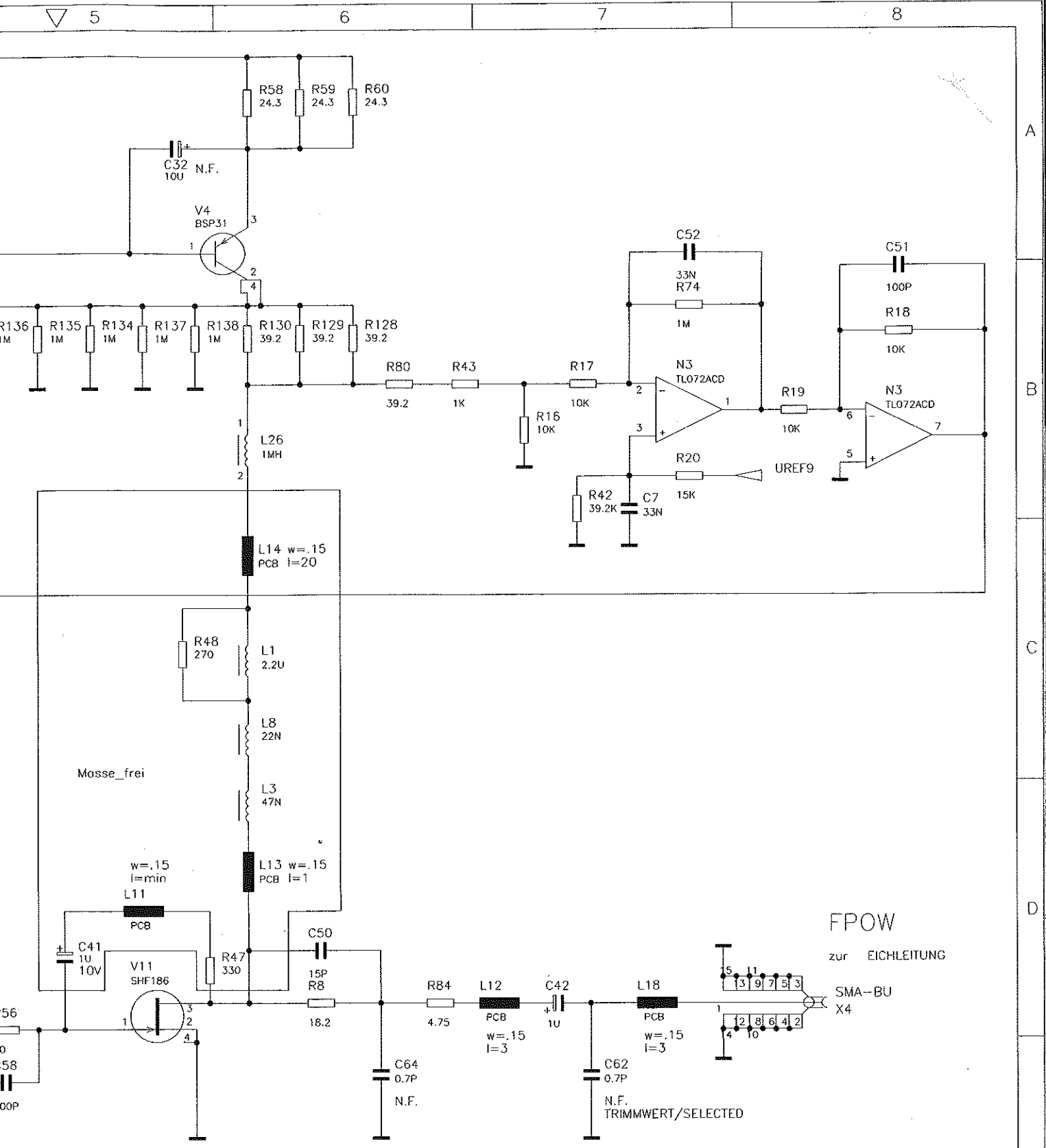

RF-AMPLIFIER1

02.03			EI	MENP	DATUM	NAME	BENENNUNG	
				BEARB.		EI	POWERMODUL	
				GEPR.		EI		
				NORM				
				PLOTT	23.9.97	IMMERZ	TOP/TOP.2	
ROHDE&SCHWARZ							ZEICHN.-NR.	
							1062.7240.01 S	
							BLATT-NR.	
							2 +	
AEND. IND.	AENDERUNGS-MITTEILUNG	DATUM	NAME	ZU GERÄT	SMY44	REG.I.V.	1062.5502	ERSTE Z.
							0000.0000.00	

+15VA1

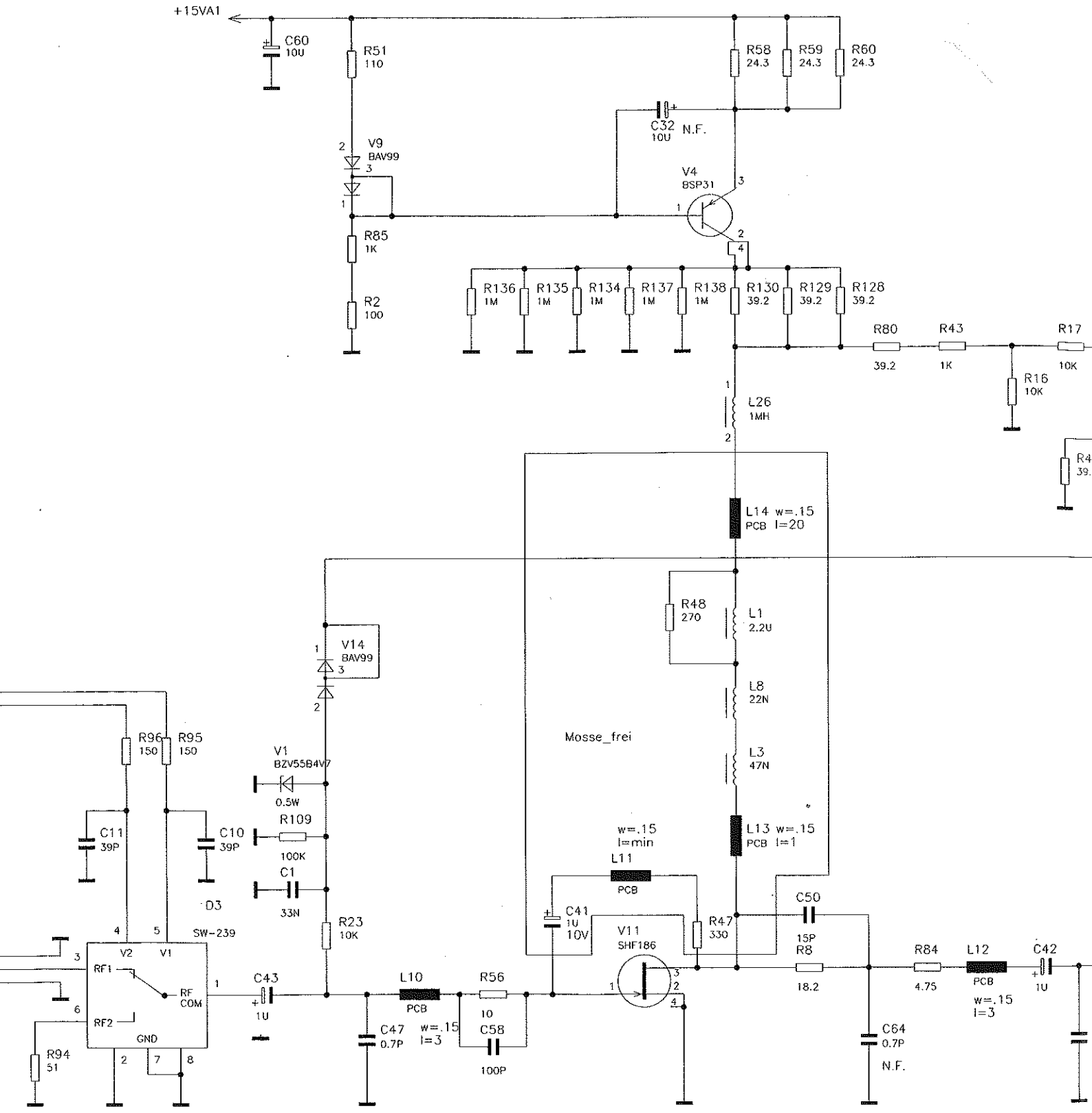

ator

RF-AMPLIFIER 1

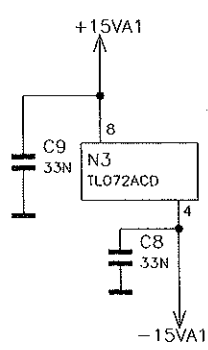

ACHTUNG: EGB !
 ELEKTROSTATISCH GEFÄHRDETE
 BAUELEMENTE ERFORDERN EINE
 BESONDERE HANDHABUNG.
ATTENTION ESD !
 ELECTROSTATIC SENSITIVE DEVICES
 REQUIRE A SPECIAL HANDLING

02.03			EI	MENP	DATUM	NAME	BEF.
				BEARB.		EI	PA
				GEPR.		EI	
				NORM			
				PLOTT	23.9.97	IMMERZ	TOP
				ROHDE&SCHWARZ			ZEI
AEND. IND.	AENDERUNGS-MITTEILUNG	DATUM	NAME	ZU GERÄT	SMY44		REG

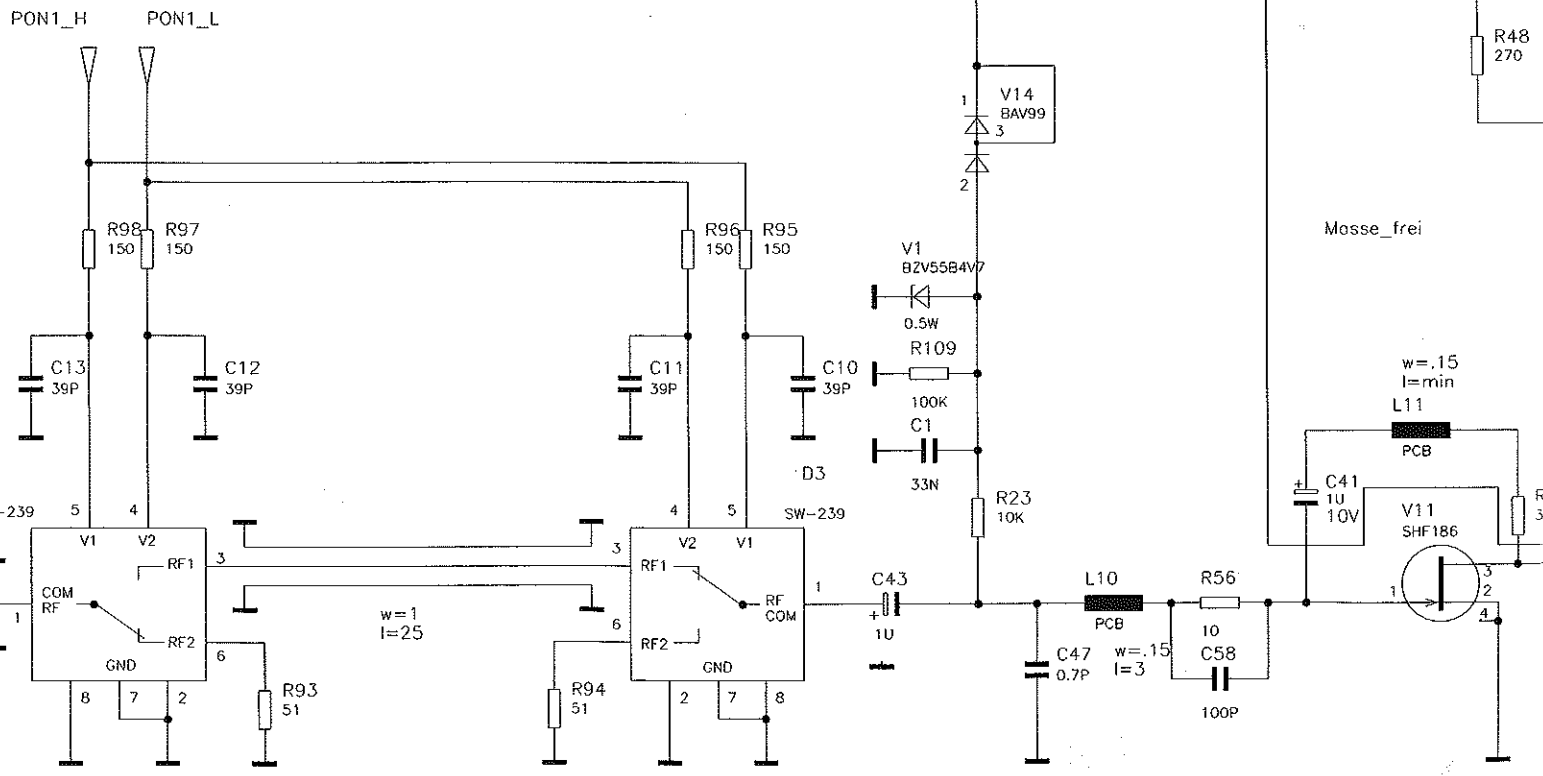
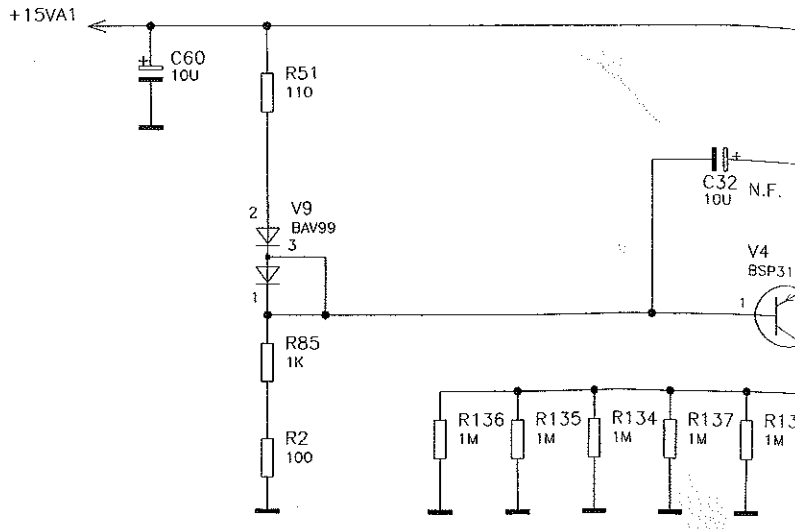

Pulsmodulator

RF-AMPLIF

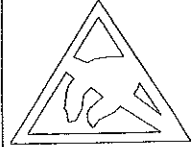
ACHTUNG: EGB !
 ELEKTROSTATISCH GEFÄHRDETE
 BAUELEMENTE ERFORDERN EINE
 BESONDERE HANDHABUNG.
ATTENTION ESD !
 ELECTROSTATIC SENSITIVE DEVICES
 REQUIRE A SPECIAL HANDLING

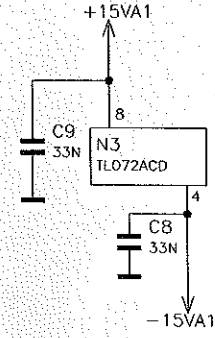

02.03
AEND. IND.
AENDERUNGS-MITTEILUNG

1

2

3

4

+15VA1

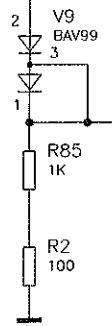

BEHALTEN WIR UNS ALLE RECHTE VOR
FÜR DIESE ÜBERTRAGUNG

PON1_H
PON1_L

PULSE1_IN

D2
SW-239

V1
B2V55B4V7

R109
100K

C1
33N

R23
10K

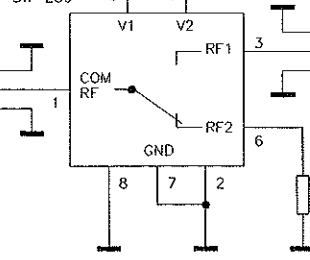
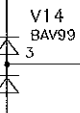

w=1
l=25

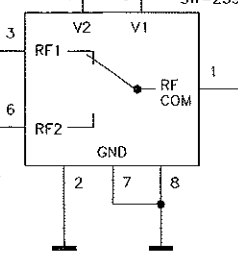

C43
1U

L10
PCB

C47
0.7P

w=15
l=3

R56
10

C58
100P

Pulsmodulator

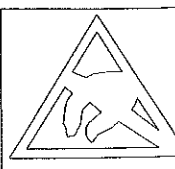

ACHTUNG: EGB !
 ELEKTROSTATISCH GEFÄHRDETE
 BAUELEMENTE ERFORDERN EINE
 BESONDERE HANDHABUNG.
ATTENTION ESD !
 ELECTROSTATIC SENSITIVE DEVICES
 REQUIRE A SPECIAL HANDLING

+15VA1

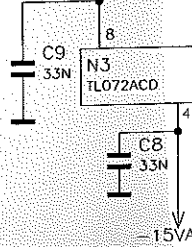

-15VA1

1

2

3

4

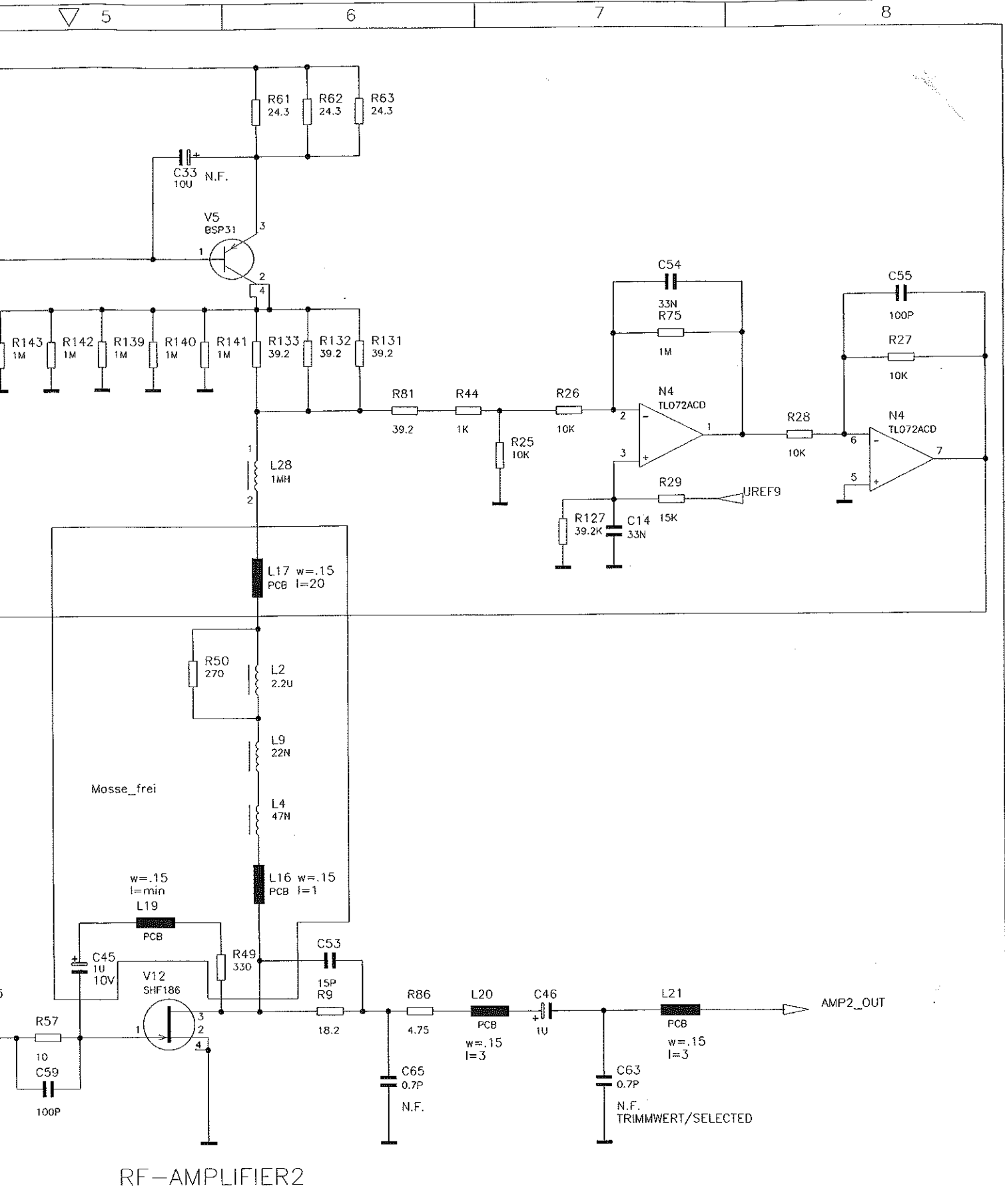

RF-AMPLIFIER2

02.03			EI	MENP	DATUM	NAME	BENENNUNG		
				BEARB.		EI	POWERMODUL		
				GEPR.		EI			
				NORM			TOP/TOP.3		
				PLOTT	23.9.97	IMMERZ	ZEICHN.-NR.		
ROHDE&SCHWARZ							1062.7240.01 S		BLATT-NR.
									3 +
AEND. IND.	AENDERUNGS-MITTEILUNG	DATUM	NAME	ZU GERAET	SMY44	REG.I.V.	1062.5502	ERSTZ.	0000.0000.00

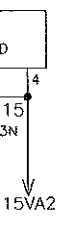

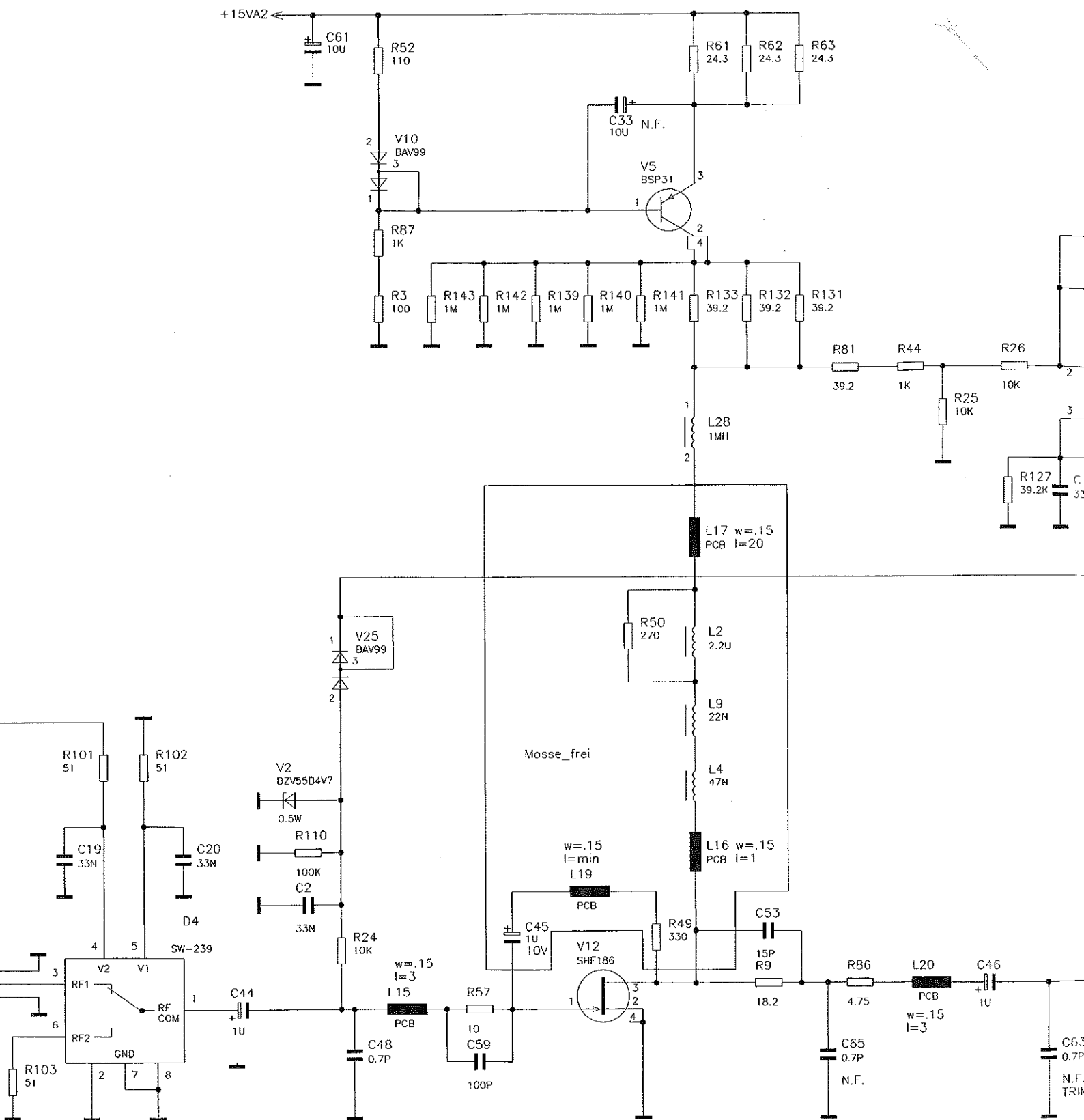

RF-AMPLIFIER2

or Referenz

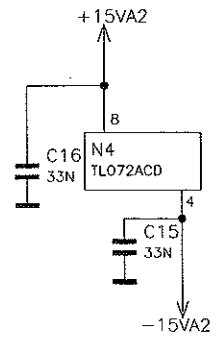

02.03			EI	MENP	DATUM	NAME	BENENN
				BEARB.		EI	POW
				GEPR.		EI	
				NORM			
				PLOTT	23.9.97	IMMERZ	TOP/TOP.3
							ZEICHN.
				ROHDE&SCHWARZ			
AEND.	AENDERUNGS-	DATUM	NAME	ZU GERAET	SMY44		REG.I.V.
	MITTEILUNG						

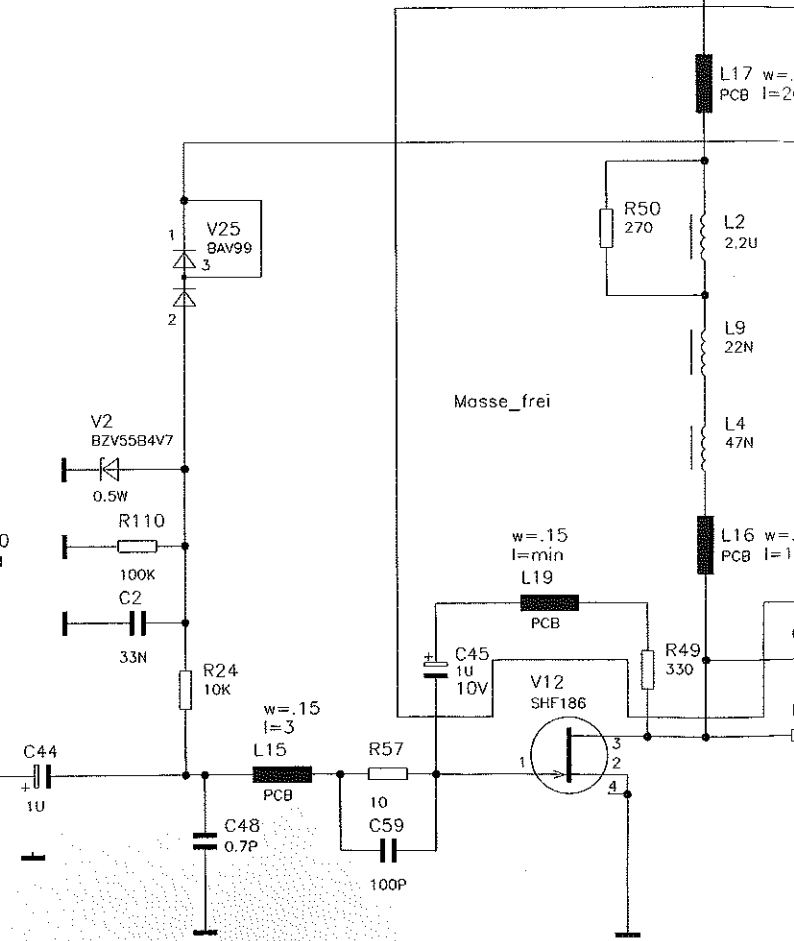
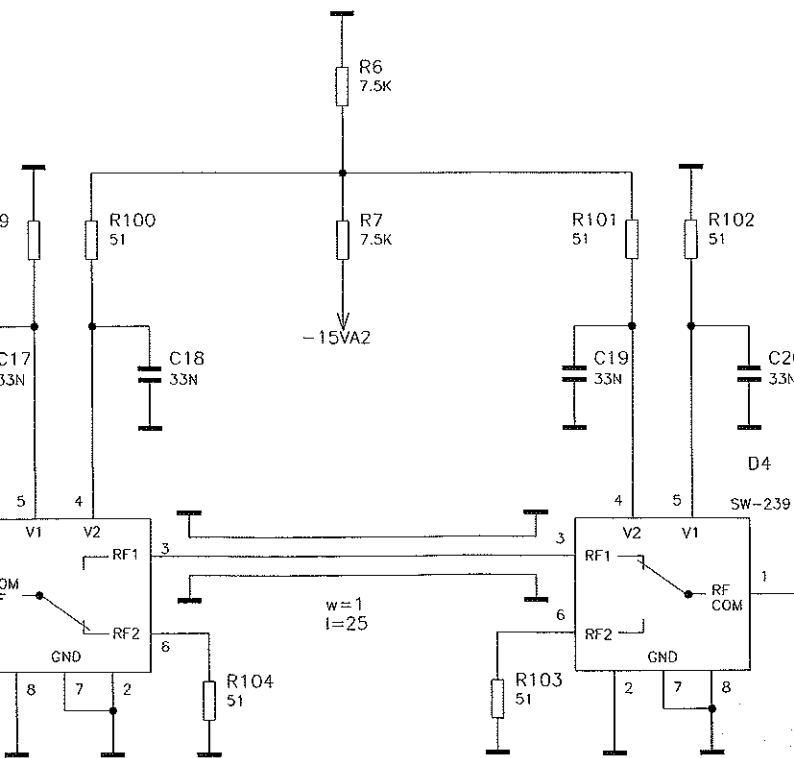
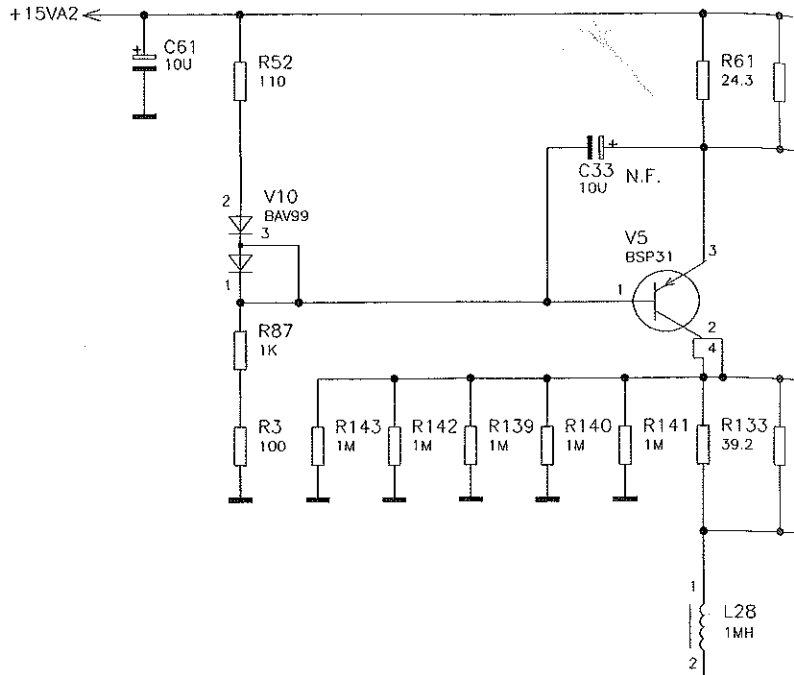

Pulsmodulator_Referenz

RF-AMPLIFIER2

ACHTUNG: EGB !
ELEKTROSTATISCH GEFÄHRDETE
BAUELEMENTE ERFORDERN EINE
BESONDERE HANDHABUNG.
ATTENTION ESD !
ELECTROSTATIC SENSITIVE DEVICES
REQUIRE A SPECIAL HANDLING

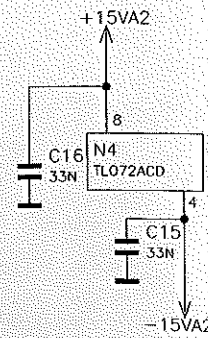

02.03		
AEND. IND.	AENDERUNGS-MITTEILUNG	DATUM

A
B
C
D
E
F

FUER DIESE UNTERLAGE
BEHALTEN WIR UNS ALLE RECHTE VOR

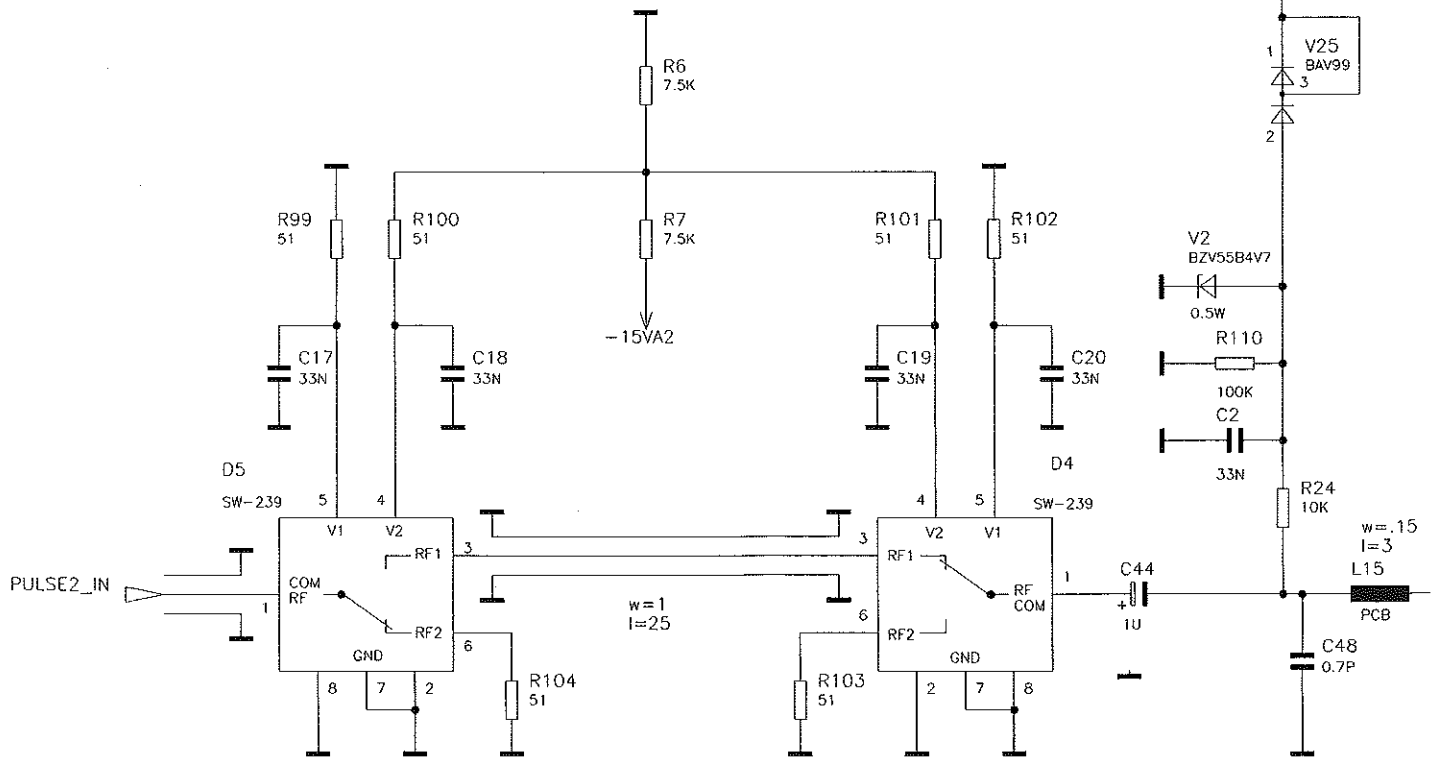
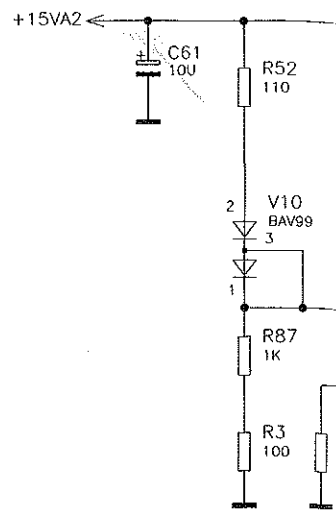

Pulsmodulator_Referenz



ACHTUNG: EGB !
ELEKTROSTATISCH GEFAEHRDETE
BAUELEMENTE ERFORDERN EINE
BESONDERE HANDHABUNG.

ATTENTION ESD !
ELECTROSTATIC SENSITIVE DEVICES
REQUIRE A SPECIAL HANDLING

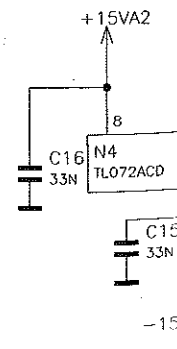

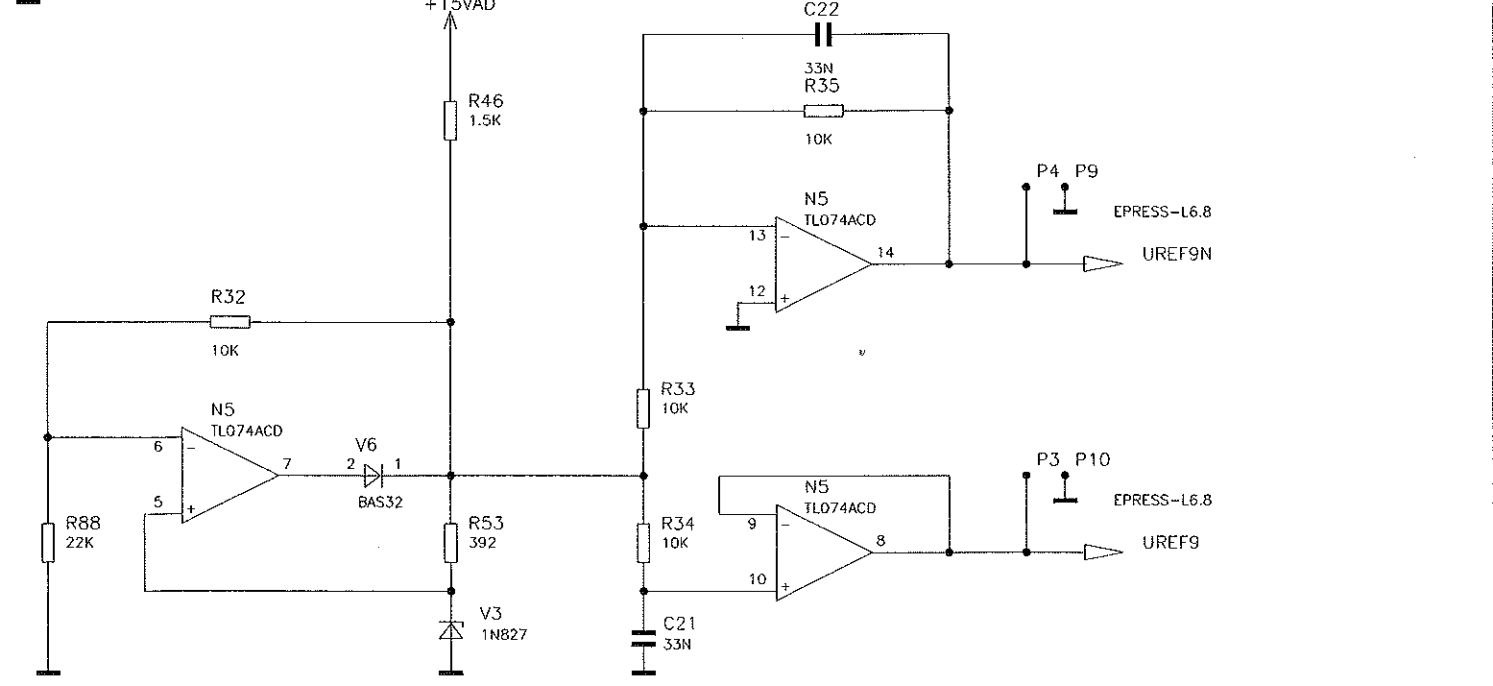
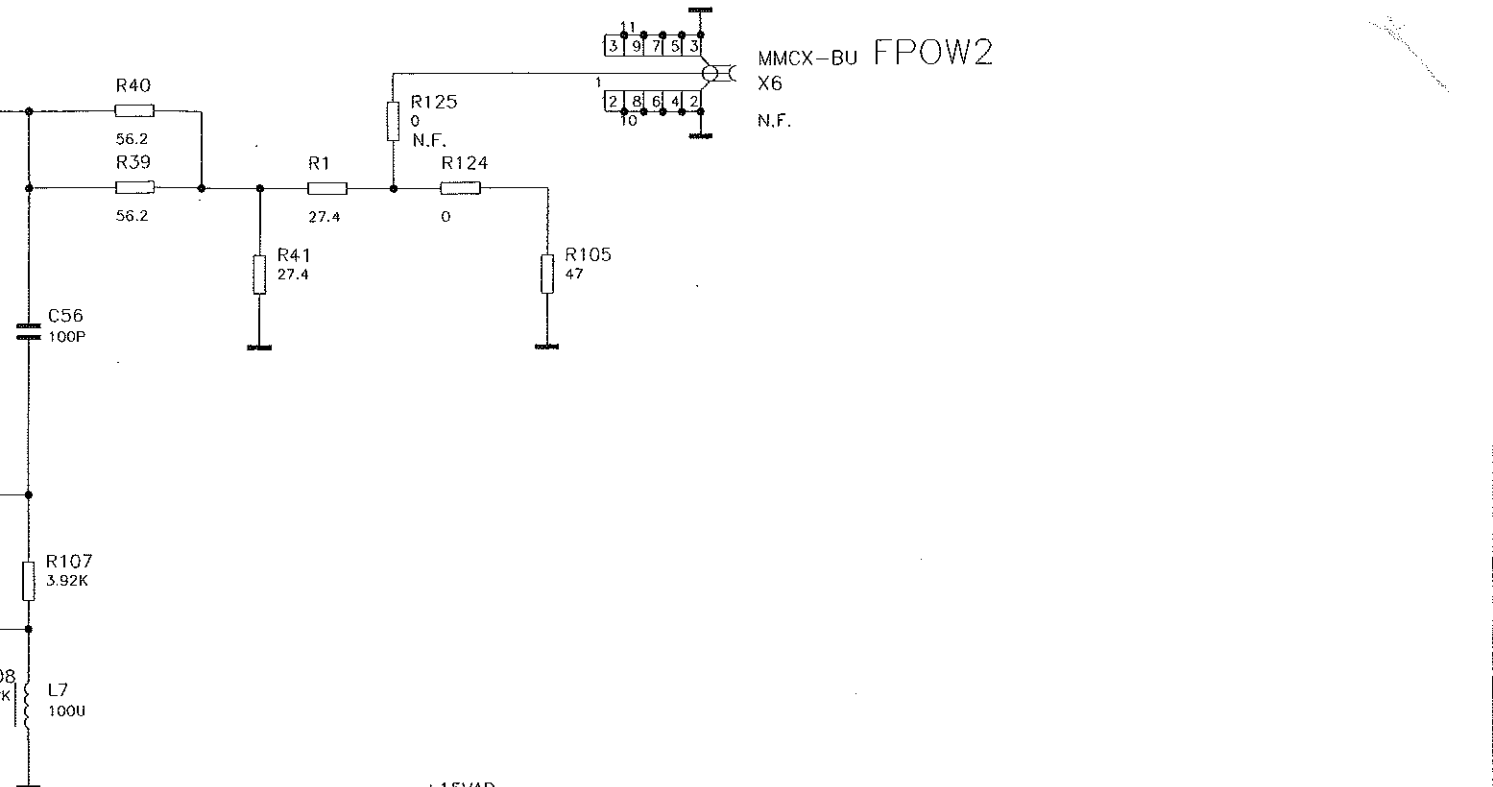

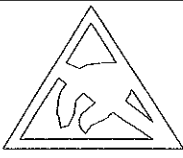

ACHTUNG: EGB !
 ELEKTROSTATISCH GEFÄHRDETE
 BAUELEMENTE ERFORDERN EINE
 BESONDERE HANDHABUNG.
ATTENTION ESD !
 ELECTROSTATIC SENSITIVE DEVICES
 REQUIRE A SPECIAL HANDLING

02.03			EI	MENP	DATUM	NAME	BENENNUNG
				BEARB.		EI	POWERMODUL
				GEPR.		EI	
				NORM			
				PLOTT	23.9.97	IMMERZ	
				ROHDE&SCHWARZ			TOP/TOP.4
							ZEICHN.-NR.
							1062.7240.01 S
							BLATT-NR.
							4 -
AEND. IND.	AENDERUNGS-MITTEILUNG	DATUM	NAME	ZU GERAET	SMY44	REG.I.V.	1062.5502
						ERSTE Z.	0000.0000.00

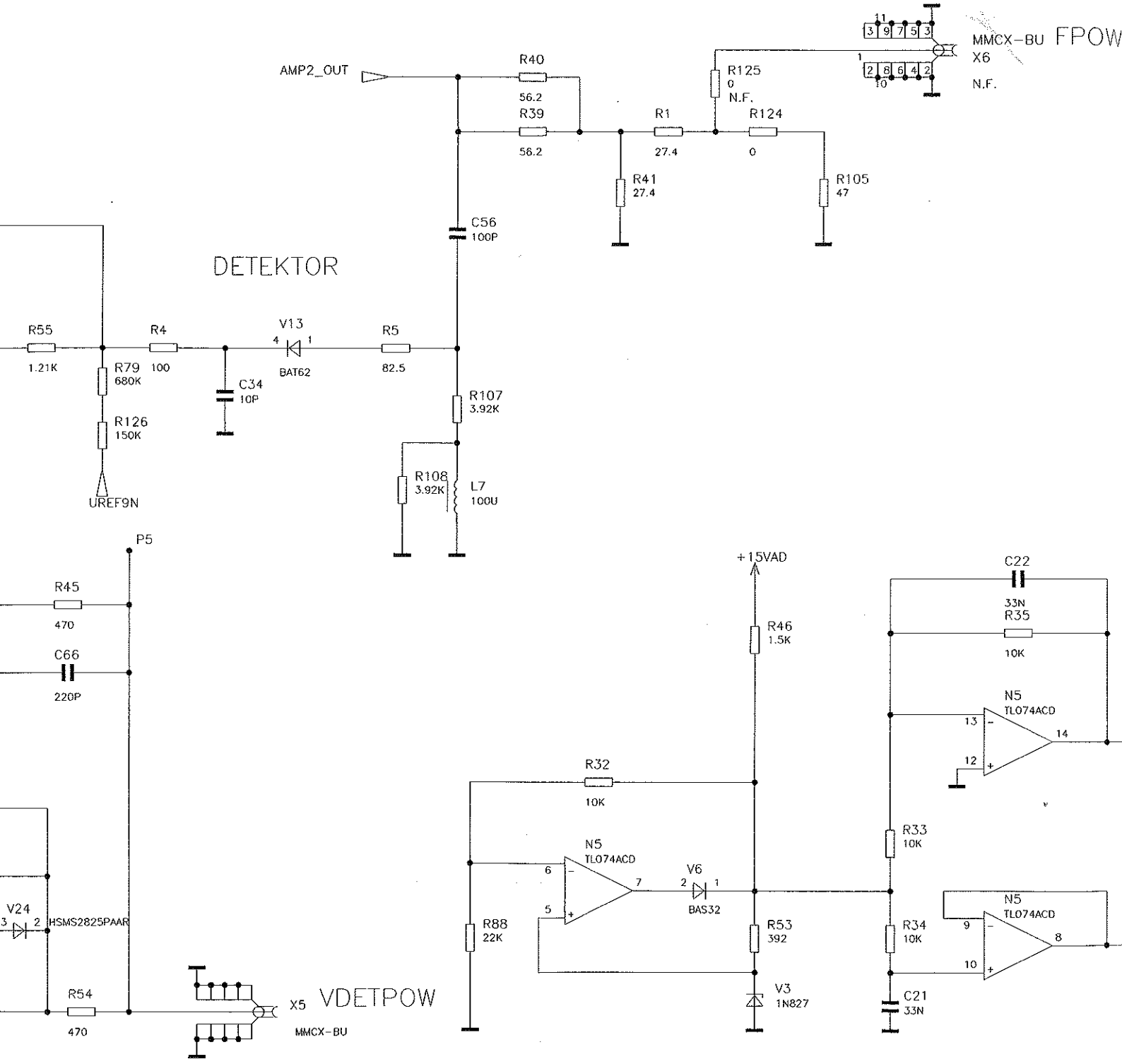

DETEKTOR

MMCX-BU FPOW
X6
N.F.

X5 VDETPOW
MMCX-BU

ACHTUNG: EGB !
 ELEKTROSTATISCH GEFÄHRDETE
 BAUELEMENTE ERFORDERN EINE
 BESONDERE HANDHABUNG.
ATTENTION ESD !
 ELECTROSTATIC SENSITIVE DEVICES
 REQUIRE A SPECIAL HANDLING

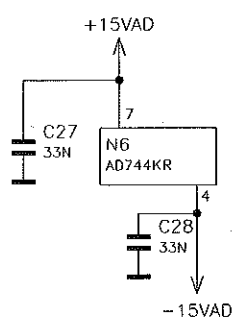
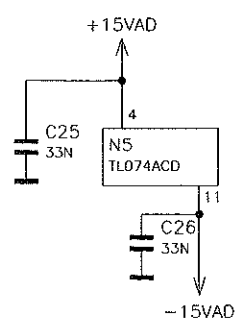

02.03			EI	MENP	DATUM	NAME	BENENNUNG
				BEARB.		EI	POWER
				GEPR.		EI	
				NORM			
				PLOTT	23.9.97	IMMERZ	TOP/TOP.4
							ZEICHN.-N
				ROHDE&SCHWARZ			
AEND. IND.	AENDERUNGS-MITTEILUNG	DATUM	NAME	ZU GERAET	SMY44		REG.I.V.

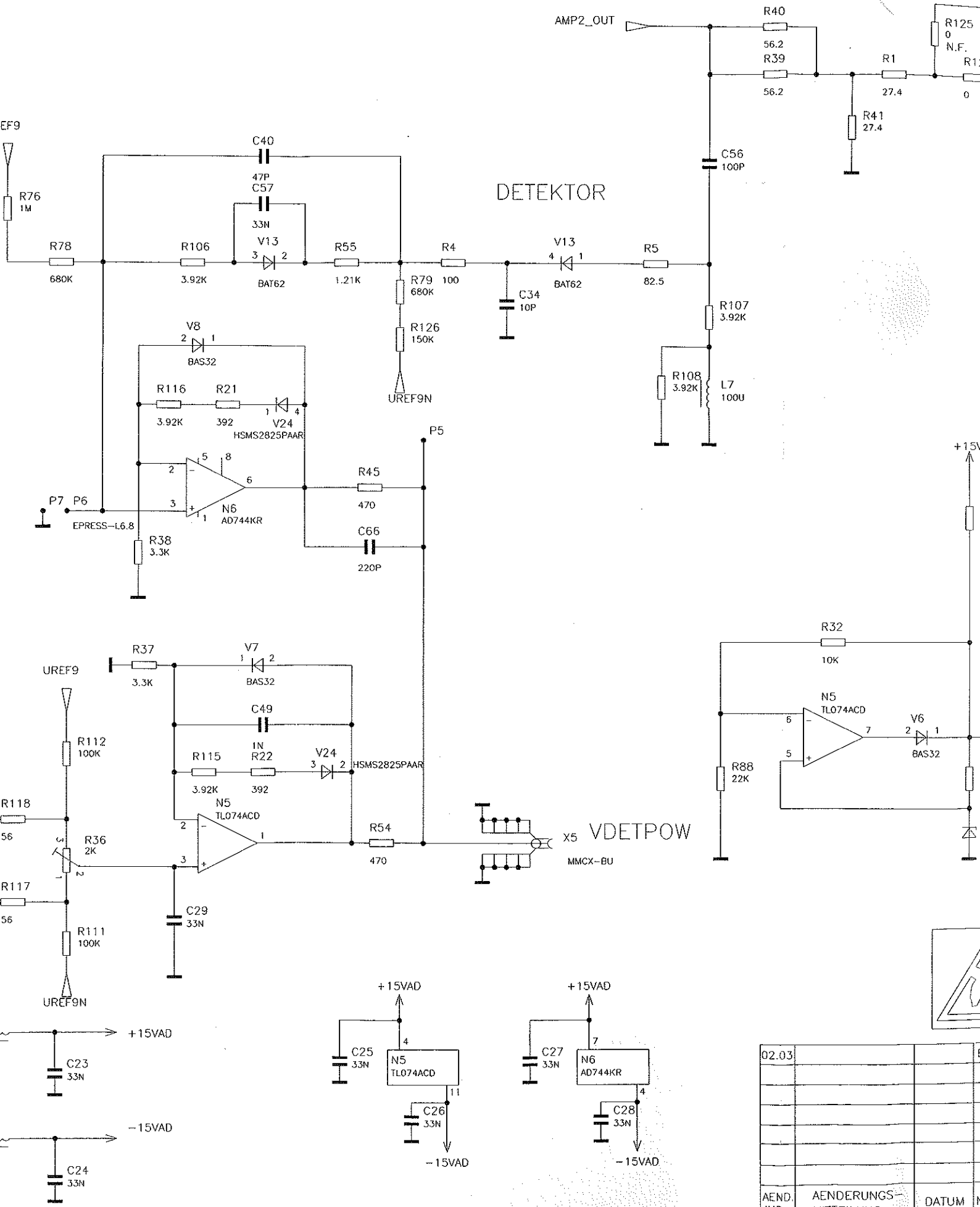

02.03		
AEND. IND.	AENDERUNGS-MITTEILUNG	DATUM

AMP2_OUT

FUER DIESE UNTERLAGE
BEHALTEN WIR UNS ALLE RECHTE VOR

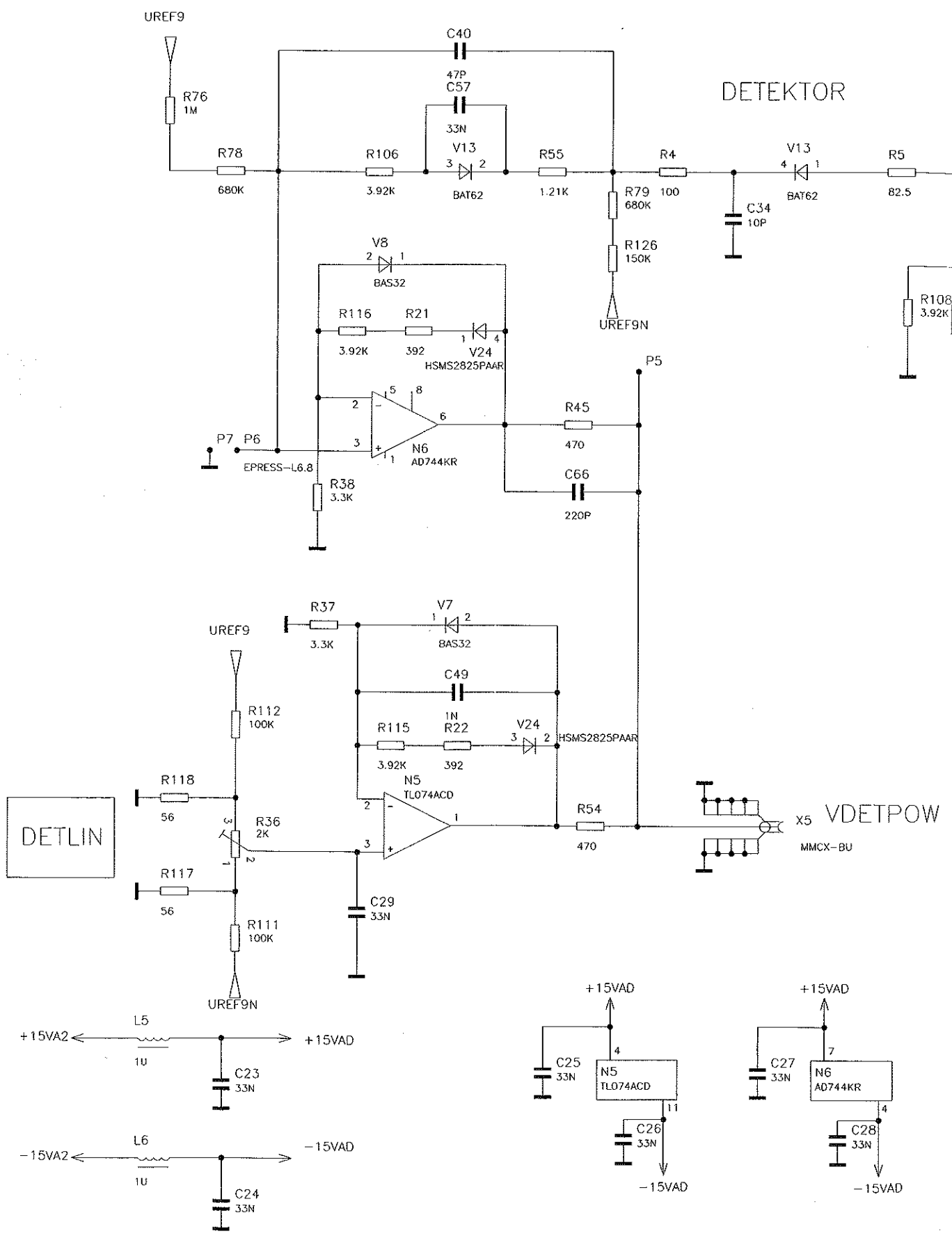

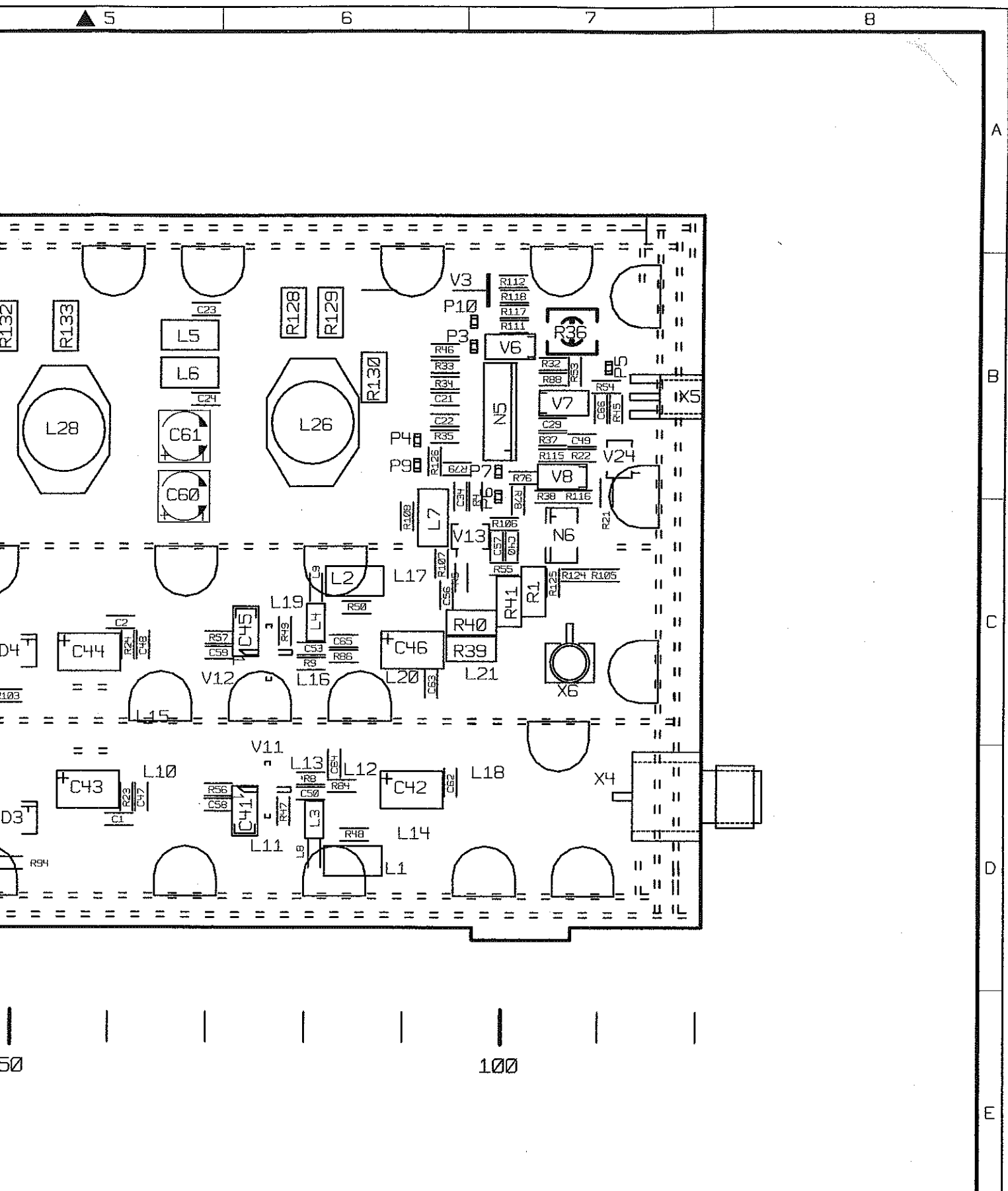

02		14.03.97	HO	1GPK	DATUM	NAME	BENENNUNG	
				BEARB.		HO	POWERMODUL	
				GEPR.		HO		
				NORM				
				PLOTT	21.04.97	HOFBERGE		
01		19.11.96	HO	ROHDE&SCHWARZ			ZEICHN.-NR.	
							1062.7240.01 D	
AEND. IND.	AENDERUNGS- MITTEILUNG	DATUM	NAME	ZU GERAET SMY44			REG. I. V.	ERSTE Z.
							1062.5502	

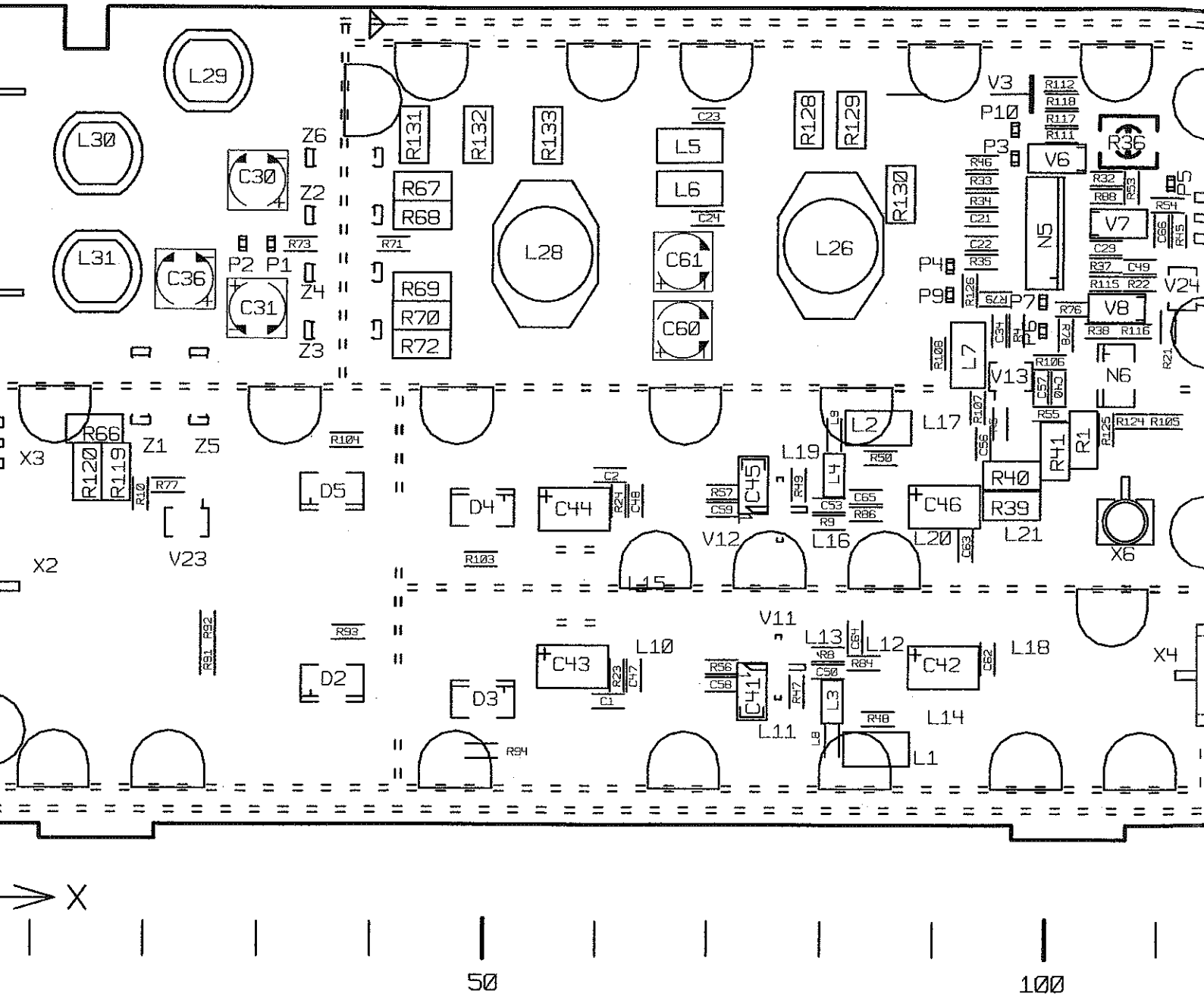

EGBI
 GEFAHRDETE
 FORDERN EINE
 HANDHABUNG.
 IN ESD!
 SENSITIVE DEVICES
 SPECIAL HANDLING

BINDENGE ANGABEN UEBER VARIANTEN,
 TRIMMWERTE, BAUTEILWERTE UND
 NICHT BESTUECKTE BAUTEILE SIEHE SA.
 FOR BINDING INFORMATION ON MODELS,
 TRIMMING AND COMPONENTS VALUES AND
 NONFITTED COMPONENTS SEE PARTS LIST.

02		14.03.97	HO	1GPK	DATUM	NAME	BENENNUNG
				BEARB.		HO	POWER
				GEPR.		HO	
				NORM			
				PLOTT	21.04.97	HOFBERGE	
01		19.11.96	HO				ZEICHN.-
AEEND.	AEENDERUNGS-	DATUM	NAME	ROHDE & SCHWARZ			106
IND.	MITTEILUNG			ZU GERAET SMY44			REG.I.V. 1

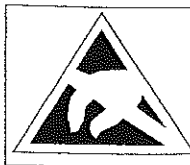
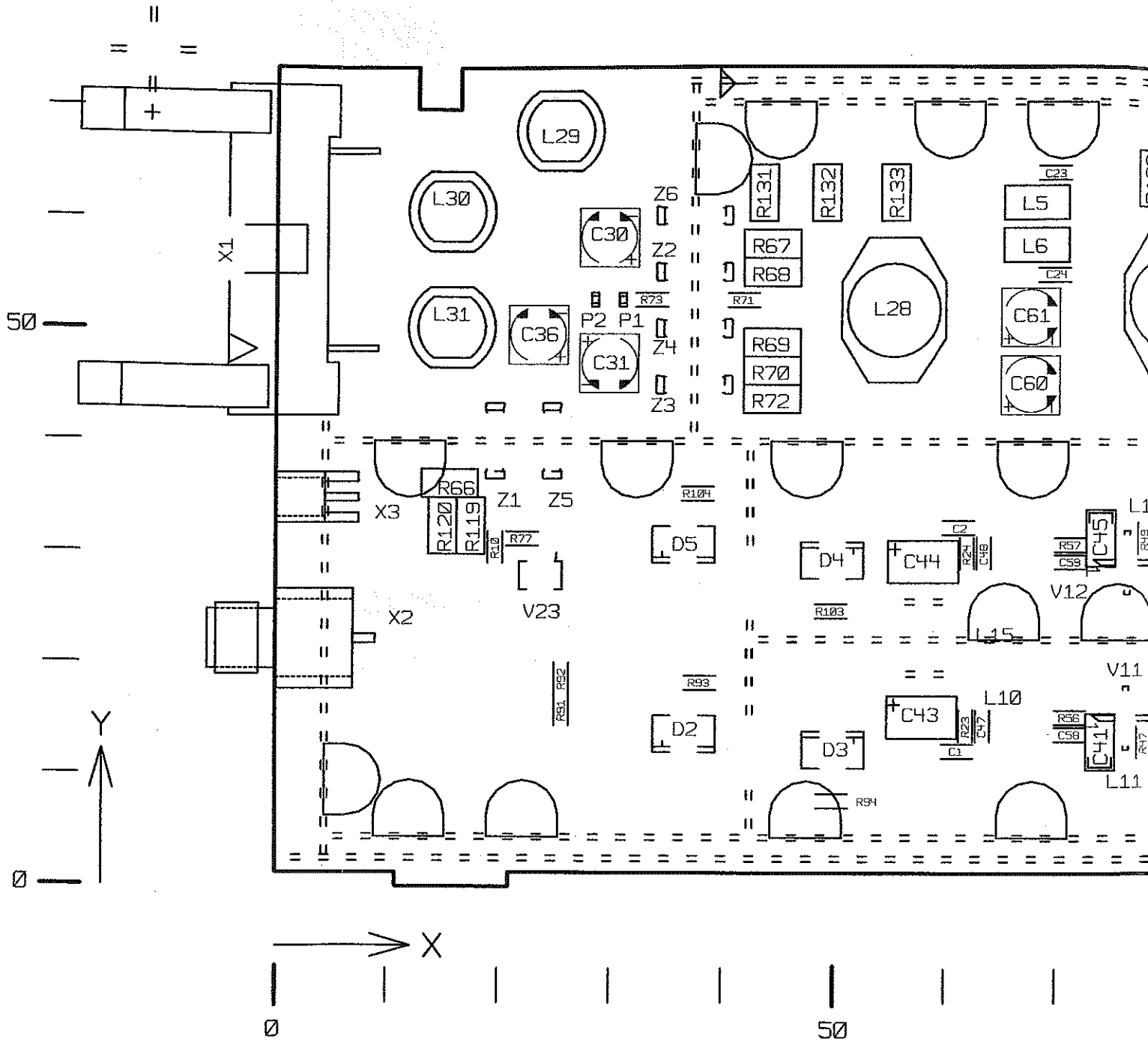

ACHTUNG: EGBI
 ELEKTROSTATISCH GEFÄHRDETE
 BAUELEMENTE ERFORDERN EINE
 BESONDERE HANDHABUNG.
ATTENTION ESD!
 ELECTROSTATIC SENSITIVE DEVICES
 REQUIRE A SPECIAL HANDLING

BINDENDE ANGABEN UEBER VARIANTEN,
 TRIMMWERTE, BAUTEILWERTE UND
 NICHT BESTUECKTE BAUTEILE SIEHE SA.

FOR BINDING INFORMATION ON MODELS,
 TRIMMING AND COMPONENTS VALUES AND
 NONFITTED COMPONENTS SEE PARTS LIST.

02		14.03.
01		19.11.
AEND. IND.	AENDERUNGS- MITTEILUNG	DATUM

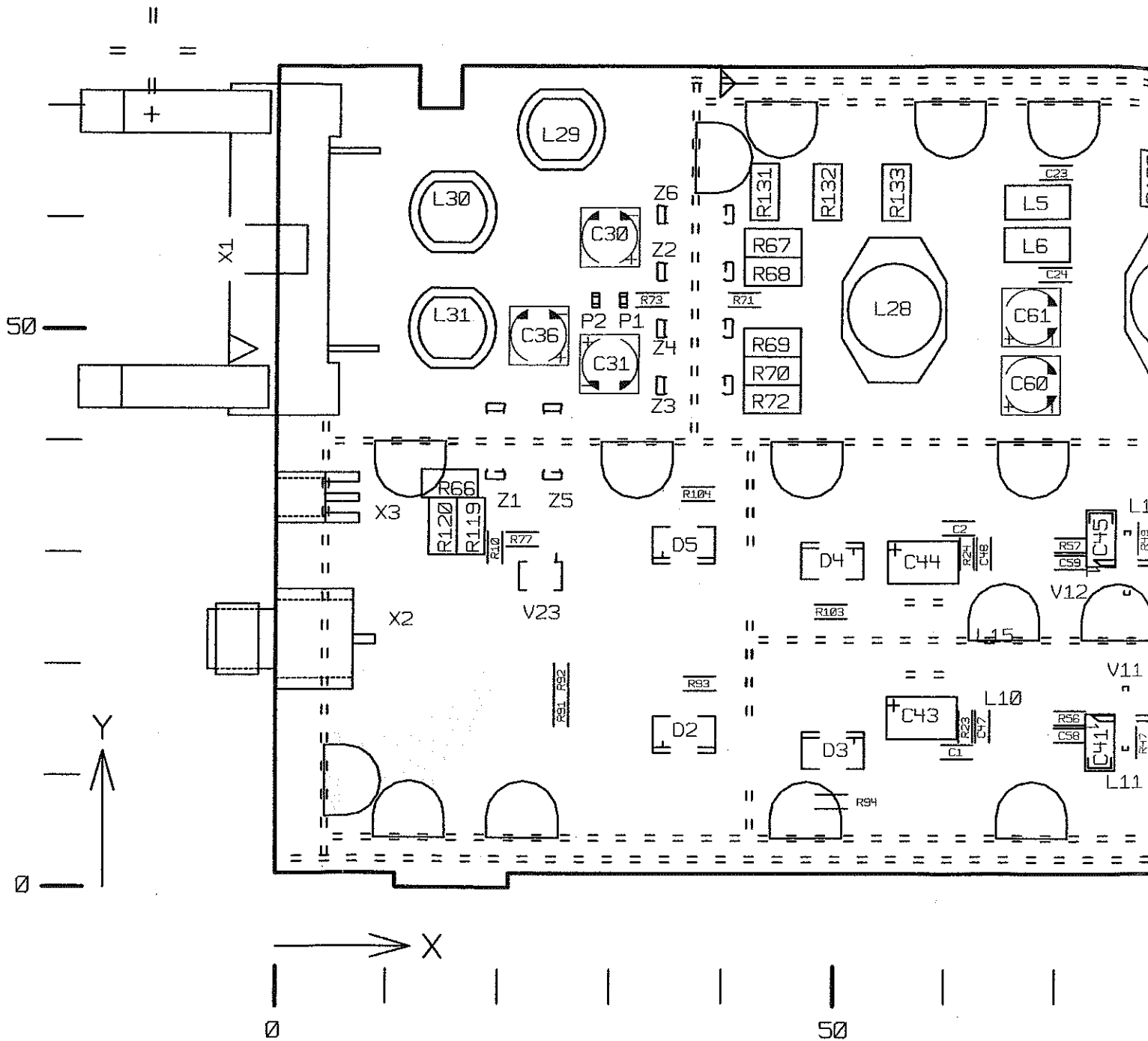

G SEITE B
B

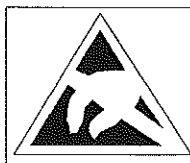

ACHTUNG: EGB!
ELEKTROSTATISCH GEFÄHRDETE
BAUELEMENTE ERFORDERN EINE
BESONDERE HANDHABUNG.
ATTENTION ESD!
ELECTROSTATIC SENSITIVE DEVICES
REQUIRE A SPECIAL HANDLING

BINDENDE ANGABEN UEBER VARIANTEN,
TRIMMWERTE, BAUTEILWERTE UND
NICHT BESTUECKTE BAUTEILE SIEHE SA.

FOR BINDING INFORMATION ON MODELS,
TRIMMING AND COMPONENTS VALUES AND
NONFITTED COMPONENTS SEE PARTS LIST.

02		14.03.
01		19.11.
AEND. IND.	AENDERUNGS- MITTEILUNG	DATUM

1 2 3 4

A

B

C

D

E

F

FÜR DIESE UNTERLAGE
BEHALTEN WIR UNS ALLE RECHTE VOR

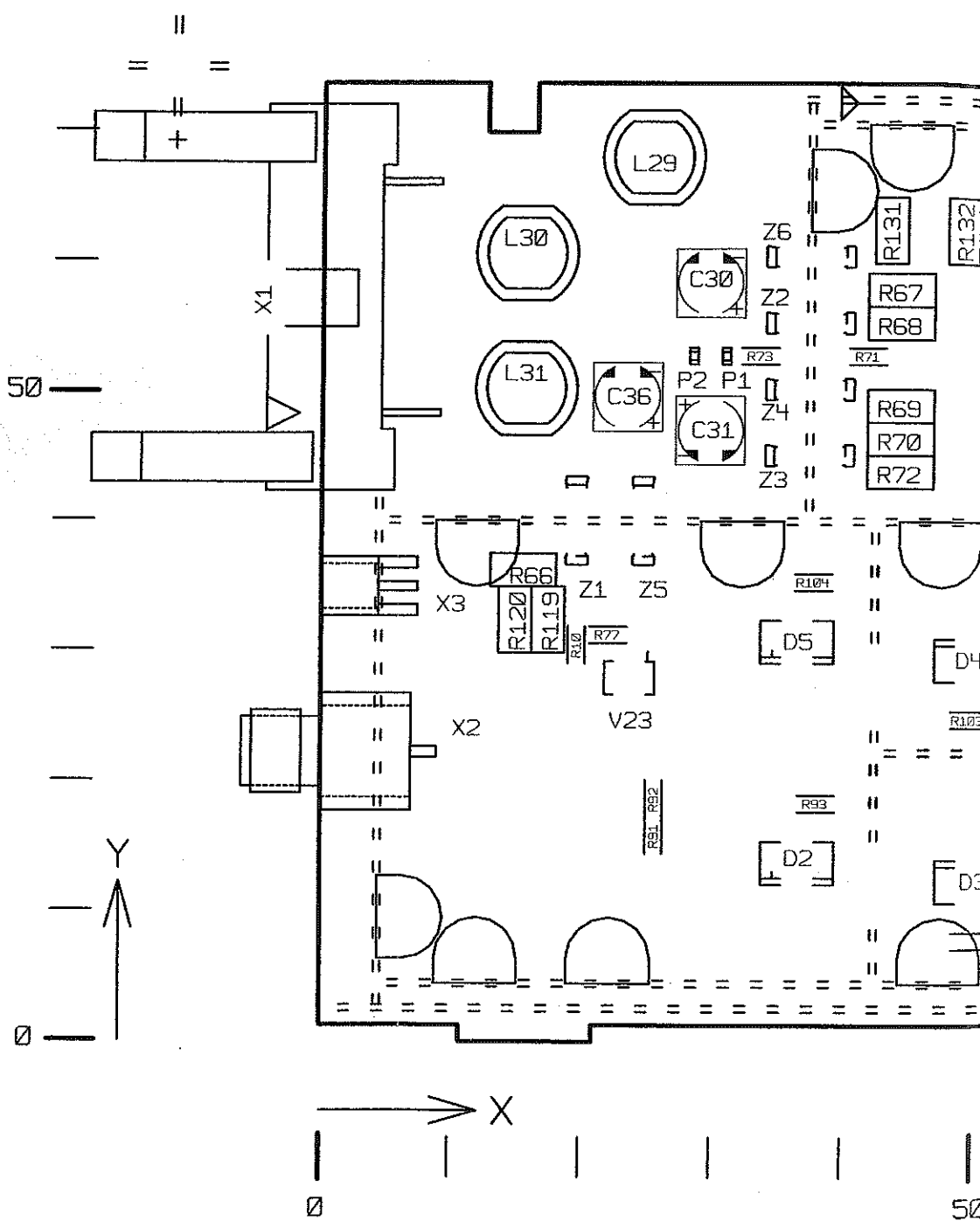

DARSTELLUNG SEITE B
VIEW ON SIDE B

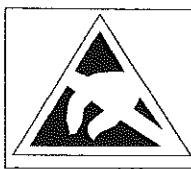

ACHTUNG: EGB!
 ELEKTROSTATISCH GEFÄHRDETE
 BAUELEMENTE ERFORDERN EINE
 BESONDERE HANDHABUNG.
ATTENTION ESD!
 ELECTROSTATIC SENSITIVE DEVICES
 REQUIRE A SPECIAL HANDLING

BINDENDE ANGABEN UEBER VARIANTEN,
 TRIMMWERTE, BAUTEILWERTE UND
 NICHT BESTUECKTE BAUTEILE SIEHE SA.
 FOR BINDING INFORMATION ON MODELS,
 TRIMMING AND COMPONENTS VALUES AND
 NONFITTED COMPONENTS SEE PARTS LIST.

1 2 3 4

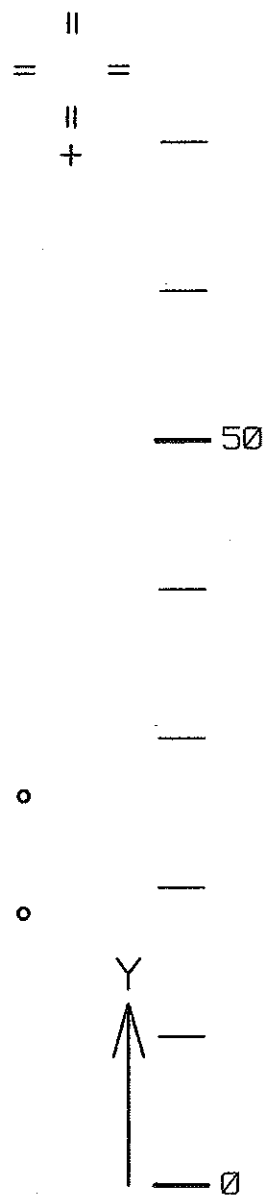
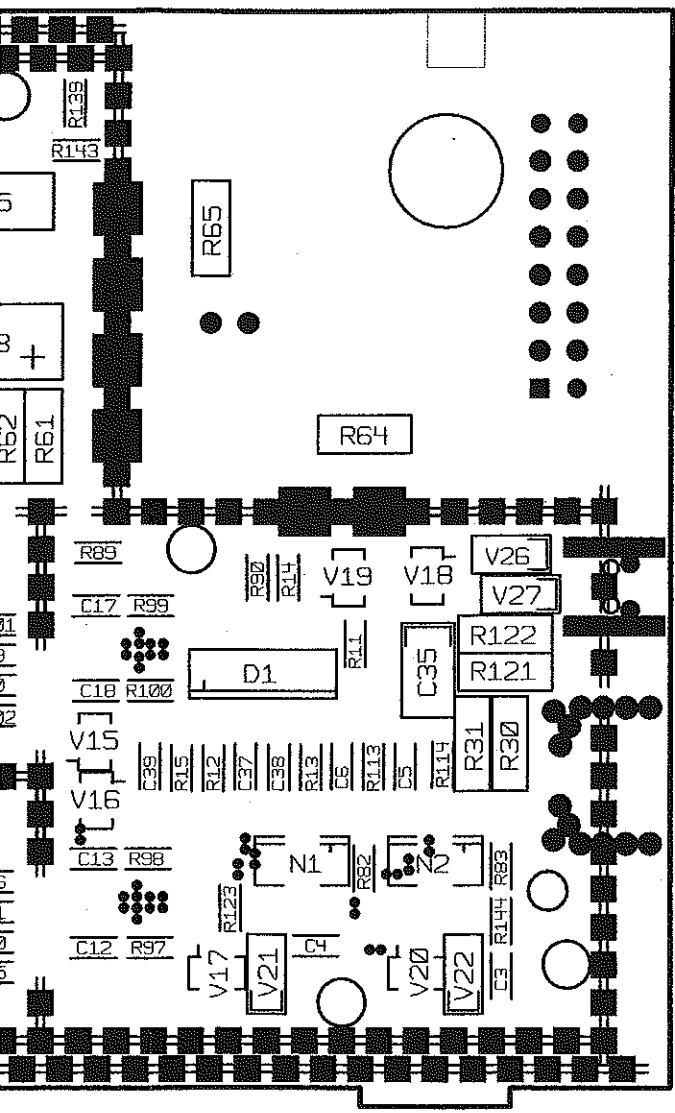

A
B
C
D
E

02		14.03.97	HO	1GPK	DATUM	NAME	BENENNUNG
				BEARB.		HO	POWERMODUL
				GEPR.		HO	
				NORM			
				PLOTT	21.04.97	HOFBERGE	
01		19.11.96	HO	ROHDE&SCHWARZ			ZEICHN.-NR.
AEND. IND.	AENDERUNGS-MITTELUNG	DATUM	NAME	ZU GERAET SMY44			1062.7240.01 D
				REG.I.V.	1062.5502	ERSTE Z.	BLATT-NR. 2-
							V. BL.

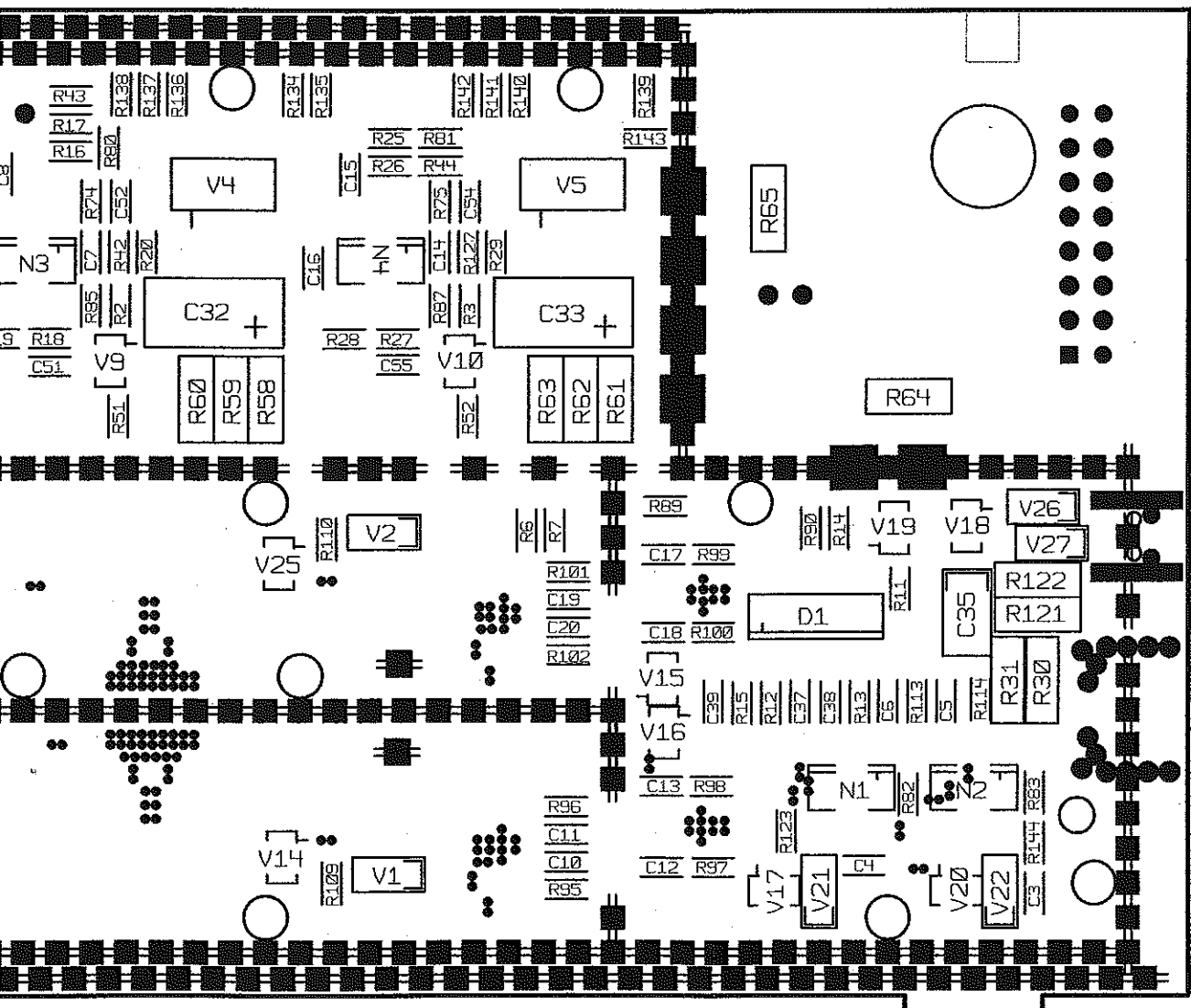

||
= || =
+ || =

○
○
○
○
○

Y
↑

X ←

50

0

BINDENDE ANGABEN UEBER VARIANTEN,
TRIMMWERTE, BAUTEILWERTE UND
NICHT BESTUECKTE BAUTEILE SIEHE SA.

FOR BINDING INFORMATION ON MODELS,
TRIMMING AND COMPONENTS VALUES AND
NONFITTED COMPONENTS SEE PARTS LIST.

02		14.03.97	HO	1GPK	DATUM	NAME	BENENNUNG POWERMODUL
				BEARB.		HO	
				GEPR.		HO	
				NORM			
				PLOTT	21.04.97	HOFBERGE	ZEICHN.-NR.
01		19.11.96	HO	ROHDE&SCHWARZ			1062.7
AEND. IND.	AENDERUNGS- MITTEILUNG	DATUM	NAME	ZU GERAET SMY44			REG.I.V. 1062.5502

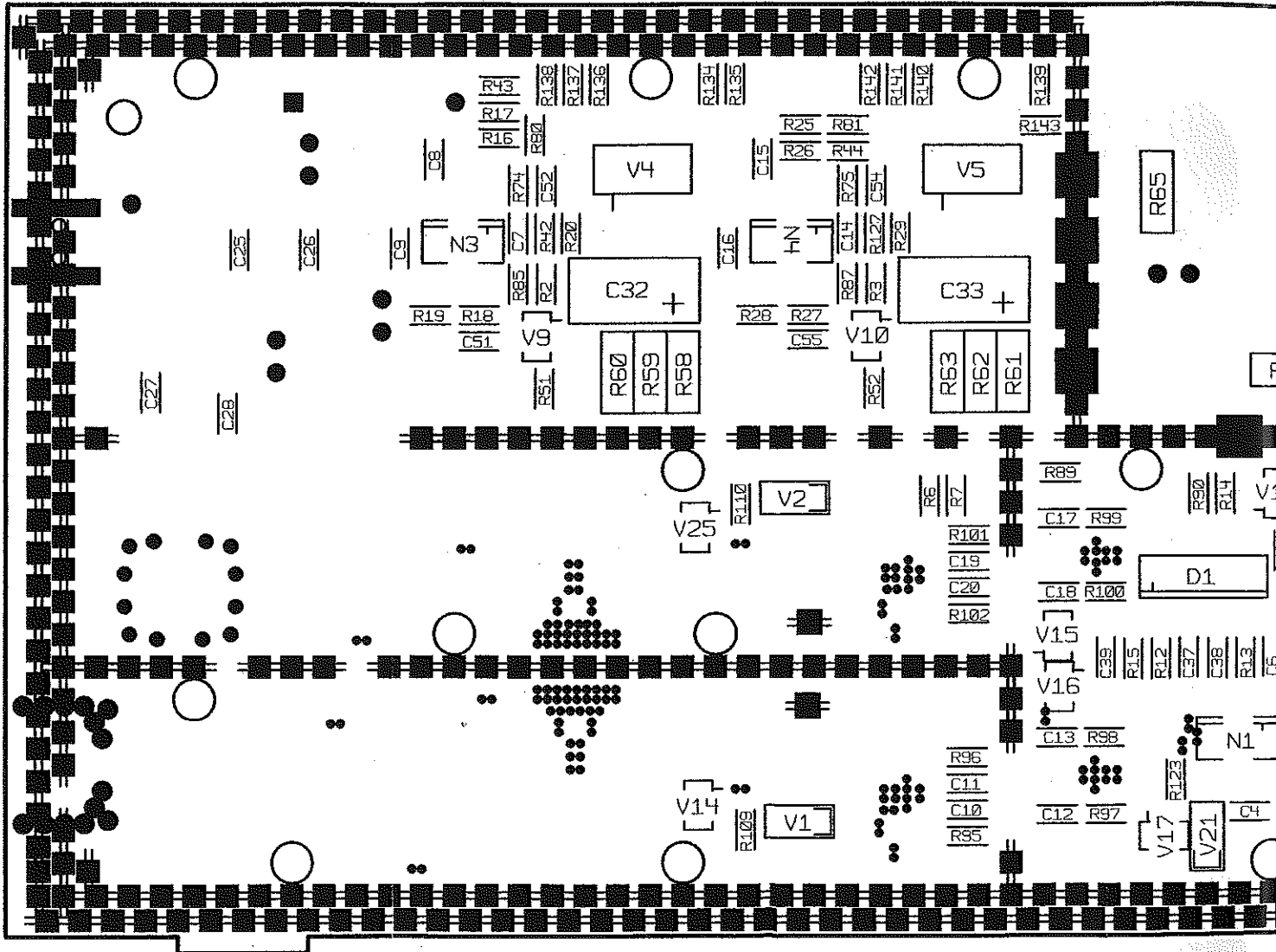

100

50

SEITE A

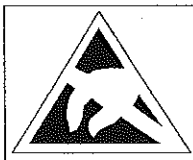

ACHTUNG: EGB!
 ELEKTROSTATISCH GEFÄHRDETE
 BAUELEMENTE ERFORDERN EINE
 BESONDERE HANDHABUNG.
ATTENTION ESD!
 ELECTROSTATIC SENSITIVE DEVICES
 REQUIRE A SPECIAL HANDLING

BINDENDE ANGABEN LIEBER VARIANTEN,
 TRIMMWERTE, BAUTEILWERTE UND
 NICHT BESTÜCKTE BAUTEILE SIEHE SA.

FOR BINDING INFORMATION ON MODELS,
 TRIMMING AND COMPONENTS VALUES AND
 NONFITTED COMPONENTS SEE PARTS LIST.

02		14.03.97
01		19.11.96
AEND. IND.	AENDERUNGS- MITTEILUNG	DATUM

1

2

3

4

A

B

C

E

F

BEHALTEN WIR UNS ALLE RECHTE VOR
FUER DIESE UNTERLAGE

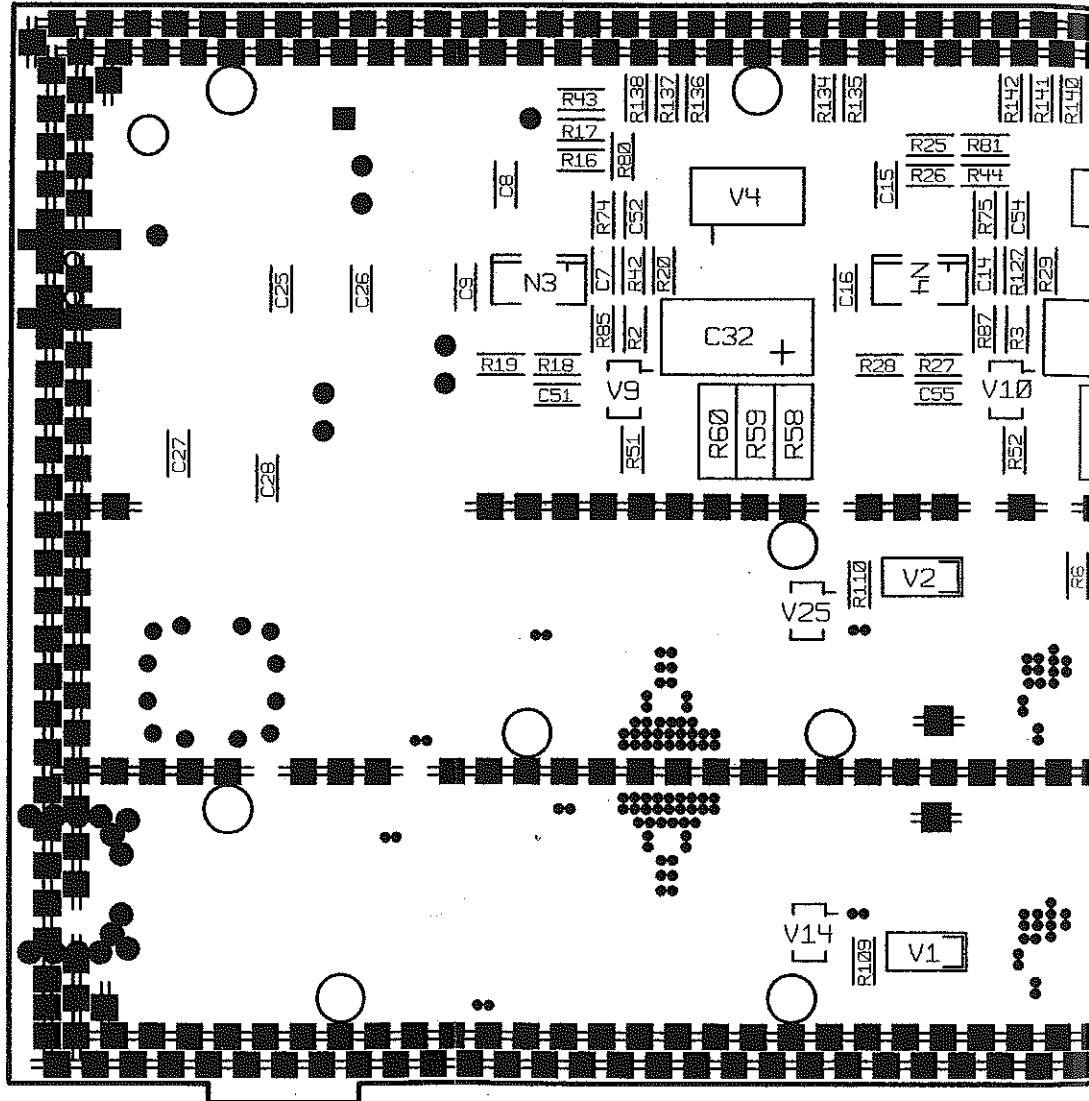

100

50

DARSTELLUNG SEITE A
VIEW ON SIDE A

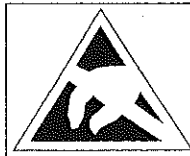

ACHTUNG: EGBI
ELEKTROSTATISCH GEFÄHRDETE
BAUELEMENTE ERFORDERN EINE
BESONDERE HANDHABUNG.
ATTENTION ESD!
ELECTROSTATIC SENSITIVE DEVICES
REQUIRE A SPECIAL HANDLING

BINDENDE ANGABEN UEBER VARIANTEN,
TRIMMIERTE, BAUTEILWERTE UND
NICHT BESTUECKTE BAUTEILE SIEHE SA.

FOR BINDING INFORMATION ON MODELS,
TRIMMING AND COMPONENTS VALUES AND
NONFITTED COMPONENTS SEE PARTS LIST.