



Sorensen

DHP Series

DC Power Supplies

**Isolated Analog Option
Programming Manual**

About AMETEK

AMETEK Programmable Power, Inc., a Division of AMETEK, Inc., is a global leader in the design and manufacture of precision, programmable power supplies for R&D, test and measurement, process control, power bus simulation and power conditioning applications across diverse industrial segments. From bench top supplies to rack-mounted industrial power subsystems, AMETEK Programmable Power is the proud manufacturer of Elgar, Sorensen, California Instruments and Power Ten brand power supplies.

AMETEK, Inc. is a leading global manufacturer of electronic instruments and electromechanical devices with annualized sales of \$2.5 billion. The Company has over 11,000 colleagues working at more than 80 manufacturing facilities and more than 80 sales and service centers in the United States and around the world.

Trademarks

AMETEK is a registered trademark of AMETEK, Inc. Sorensen is a trademark owned by AMETEK, Inc. Other trademarks, registered trademarks, and product names are the property of their respective owners and are used herein for identification purposes only.

Notice of Copyright

DHP Series DC Power Supplies Isolated Analog Option Programming Manual © 2002 AMETEK Programmable Power, Inc. All rights reserved.

Exclusion for Documentation

UNLESS SPECIFICALLY AGREED TO IN WRITING, AMETEK PROGRAMMABLE POWER, INC. ("AMETEK"):

- (a) MAKES NO WARRANTY AS TO THE ACCURACY, SUFFICIENCY OR SUITABILITY OF ANY TECHNICAL OR OTHER INFORMATION PROVIDED IN ITS MANUALS OR OTHER DOCUMENTATION.
- (b) ASSUMES NO RESPONSIBILITY OR LIABILITY FOR LOSSES, DAMAGES, COSTS OR EXPENSES, WHETHER SPECIAL, DIRECT, INDIRECT, CONSEQUENTIAL OR INCIDENTAL, WHICH MIGHT ARISE OUT OF THE USE OF SUCH INFORMATION. THE USE OF ANY SUCH INFORMATION WILL BE ENTIRELY AT THE USER'S RISK, AND
- (c) REMINDS YOU THAT IF THIS MANUAL IS IN ANY LANGUAGE OTHER THAN ENGLISH, ALTHOUGH STEPS HAVE BEEN TAKEN TO MAINTAIN THE ACCURACY OF THE TRANSLATION, THE ACCURACY CANNOT BE GUARANTEED. APPROVED AMETEK CONTENT IS CONTAINED WITH THE ENGLISH LANGUAGE VERSION, WHICH IS POSTED AT WWW.PROGRAMMABLEPOWER.COM.

Date and Revision

December 2008 Revision B

Part Number

M550006-01



Contact Information

Telephone: 800 733 5427 (toll free in North America)
858 450 0085 (direct)
Fax: 858 458 0267
Email: sales@programmablepower.com
service@programmablepower.com
Web: www.programmablepower.com

This page intentionally left blank.

Important Safety Instructions

Before applying power to the system, verify that your product is configured properly for your particular application.

	Hazardous voltages may be present when covers are removed. Qualified personnel must use extreme caution when servicing this equipment. Circuit boards, test points, and output voltages also may be floating above (below) chassis ground.
	The equipment used contains ESD sensitive parts. When installing equipment, follow ESD Safety Procedures. Electrostatic discharges might cause damage to the equipment.

Only *qualified personnel* who deal with attendant hazards in power supplies, are allowed to perform installation and servicing.

Ensure that the AC power line ground is connected properly to the Power Rack input connector or chassis. Similarly, other power ground lines including those to application and maintenance equipment *must* be grounded properly for both personnel and equipment safety.

Always ensure that facility AC input power is de-energized prior to connecting or disconnecting any cable.

In normal operation, the operator does not have access to hazardous voltages within the chassis. However, depending on the user's application configuration, **HIGH VOLTAGES HAZARDOUS TO HUMAN SAFETY** may be normally generated on the output terminals. The customer/user must ensure that the output power lines are labeled properly as to the safety hazards and that any inadvertent contact with hazardous voltages is eliminated.

Guard against risks of electrical shock during open cover checks by not touching any portion of the electrical circuits. Even when power is off, capacitors may retain an electrical charge. Use safety glasses during open cover checks to avoid personal injury by any sudden component failure.

Neither AMETEK Programmable Power Inc., San Diego, California, USA, nor any of the subsidiary sales organizations can accept any responsibility for personnel, material or inconsequential injury, loss or damage that results from improper use of the equipment and accessories.

SAFETY SYMBOLS

 **WARNING**
Risk of Electrical Shock

 **CAUTION**
Refer to Accompanying Documents

 Off (Supply)

 Direct Current (DC)

 Standby (Supply)

 Alternating Current (AC)

 On (Supply)

 Three-Phase Alternating Current

 Protective Conductor Terminal

 Earth (Ground) Terminal

 Fuse

 Chassis Ground

This page intentionally left blank.

About This Manual

This manual has been written expressly for the Sorensen DHP and DCS Series of power supplies which have been designed and certified to meet the 1997 Low Voltage and Electromagnetic Compatibility Directive Requirements of the European Community. All units in this series comply with these directives.

Since the Low Voltage Directive is to ensure the safety of the equipment operator, universal graphic symbols (see below) have been used both on the unit itself and in this manual to warn the operator of potentially hazardous situations.

This page intentionally left blank.

TABLE OF CONTENTS

Chapter 1 DESCRIPTION OF EQUIPMENT	1-1
1.1 PURPOSE AND CAPABILITIES.....	1-1
1.2 TECHNICAL CHARACTERISTICS.....	1-1
Chapter 2 OPERATING INSTRUCTIONS	2-1
2.1 REMOTE CURRENT PROGRAMMING.....	2-1
2.2 REMOTE VOLTAGE PROGRAMMING.....	2-1

LIST OF FIGURES

Figure 2-1 Remote Current Programming Using 0-5 or 0-10 VDC Source.....	2-4
Figure 2-2 Remote Voltage Programming Using 0-5 or 0-10 VDC Source	2-4

LIST OF TABLES

Table 1-1 Isolated Analog Option Technical Characteristics	1-1
Table 2-1 J1 Designations and Functions	2-2

Chapter 1

DESCRIPTION OF EQUIPMENT

1.1 PURPOSE AND CAPABILITIES

The Isolated Analog Option for all Sorensen DHP Series power supply models fully isolates remote control signals. This isolation allows users to control power supplies not connected to a common ground. In addition, in systems with high ambient noise or with large ground loop currents the control ground can be isolated from power ground eliminating problems.

1.2 TECHNICAL CHARACTERISTICS

The characteristics for the Isolated Analog Option are listed in Tables 1-1.

Table 1-1
Isolated Analog Option Technical Characteristics

PARAMETERS	SPECIFICATIONS
ELECTRICAL CHARACTERISTICS	
Input to Output Isolation	500 V
Linearity Control to Power Output	$\pm 1\%$ of full scale from 20%-100% of output
Isolation Mode Rejection	10 kV / μs
Isolation Mode Rejection Ratio	>100dB

This page intentionally left blank.

Chapter 2

OPERATING INSTRUCTIONS

2.1 REMOTE CURRENT PROGRAMMING

A DC voltage source for remote current programming is connected between J1-10 (IP 5V) or J1-16 (IP 10V) and the return terminal J1-23 (IP RTN). The voltage coefficient for 5V remote current programming is 50 millivolts = 1% of rated output current, i.e., for a 300 amp model, each 50 millivolts of programming voltage equals 3 amps of output current. The voltage coefficient for 10V remote current programming is 100 millivolts = 1% of rated output current, i.e., for a 300 amp model, each 100 millivolts of programming voltage equals 3 amps of output current.

In addition to the above mentioned requirements, settings from the digital front panel must also be selected to enable remote current programming. The steps are as follows.

Set the output current to 0V and set the output voltage to the maximum desired voltage. Press the **MENU** key until *Control Source* is shown on the screen. At this time, use the keys to select *Remote Analog*, and press the **ENTER** key.

Next, press the **MENU** key until *Analog Control Option* is shown. At this time, use the keys to select *5V Current Only* (Note: In order for proper operation, this option is to be selected for both 5V and 10V remote current programming schemes), and press the **ENTER** key.

2.2 REMOTE VOLTAGE PROGRAMMING

A DC voltage source for remote voltage programming is connected between J1-9 (VP 5V) or J1-15 (VP 10V) and the return terminal J1-20 (VP RTN). The voltage coefficient for 5V remote voltage programming is 5 volts = 100% of rated output voltage. The voltage coefficient for 10V remote voltage programming is 10 volts = 100% of rated output voltage. To program voltage slightly above the rated output will not damage the unit, but degraded performance may result

In addition to the above mentioned requirements, settings from the digital front panel must also be selected to enable remote voltage programming. The steps are as follows.

Set the output voltage to 0V and set the output current to the maximum desired current. Press the **MENU** key until *Control Source* is shown on the screen. At this time, use the keys to select *Remote Analog*, and press the **ENTER** key.

Next, press the **MENU** key until *Analog Control Option* is shown. At this time, use the keys to select *5V Voltage Only* (Note: In order for proper operation, this option is to be

selected for both 5V and 10V remote voltage programming schemes), and press the **ENTER** key.

Table 2-1
J1 Designations and Functions

J1 DESIGNATOR	SCHEMATIC SYMBOL	FUNCTIONAL DESCRIPTION
1	ISO ON/OFF	Isolated remote on/off. Externally supplied AC/DC voltage source for on/off control. A positive (+) voltage will turn on the supply. This input control is optically isolated from the power supply circuit up to 500 VDC.
2	ISO RTN	Isolated circuit return used with isolated on/off control J1-1 and J1-14.
3	-	Factory use only.
4	VP RTN	Voltage programming return. Used with J1-9, J1-15 or J1-21 and must be referenced to or within $\pm 3V$ of the circuit common (same as pin 20).
5	ON/OFF	Remote on/off. Switch/relay contacts or a direct short between this terminal and circuit common turns on the unit.
6	COM	Circuit Common
7	I MON	Output current monitor. 0-10 VDC equals 0-100% rated current.
8	-	Factory use only.
9	VP 5V	Remote voltage programming using a 0-5 VDC source.
10	IP 5V	Remote current programming using a 0-5VDC source.
11	-	Factory use only.
12	-	Factory use only.
13	-	Factory use only.
14	ISO TTL/CMOS	Isolated TTL/CMOS on/off control. A high state TTL/CMOS voltage turns on the power supply, and a low state or open connection turns the supply off.

Table 2-1
J1 Designations and functions - Continued

J1 DESIGNATOR	SCHEMATIC SYMBOL	FUNCTIONAL DESCRIPTION
15	VP 10V	Remote voltage programming using a 0-10 VDC source.
16	IP 10V	Remote current programming using a 0-10 VDC source.
17	-	Factory use only
18	-	Factory use only
19	V MON	Output voltage monitor. 0-10 VDC equals to 0-100% rated voltage.
20	VP RTN	Voltage programming return. Used with J1-9, J1-15 or J1-21 and must be referenced to or within $\pm 3V$ of the circuit common (same as pin 4).
21	-	Factory use only
22	-	Factory use only
23	IP RTN	Current programming return. Used with pins 10, 16 or 22 for remote current programming and must be referenced to or within $\pm 3V$ of the circuit common (same as pin 23).
24	COM	Circuit common.
25	IP RTN	Current programming return. Used with pins 10, 16 or 22 for remote current programming and must be referenced to or within $\pm 3V$ of the circuit common (same as pin 23).

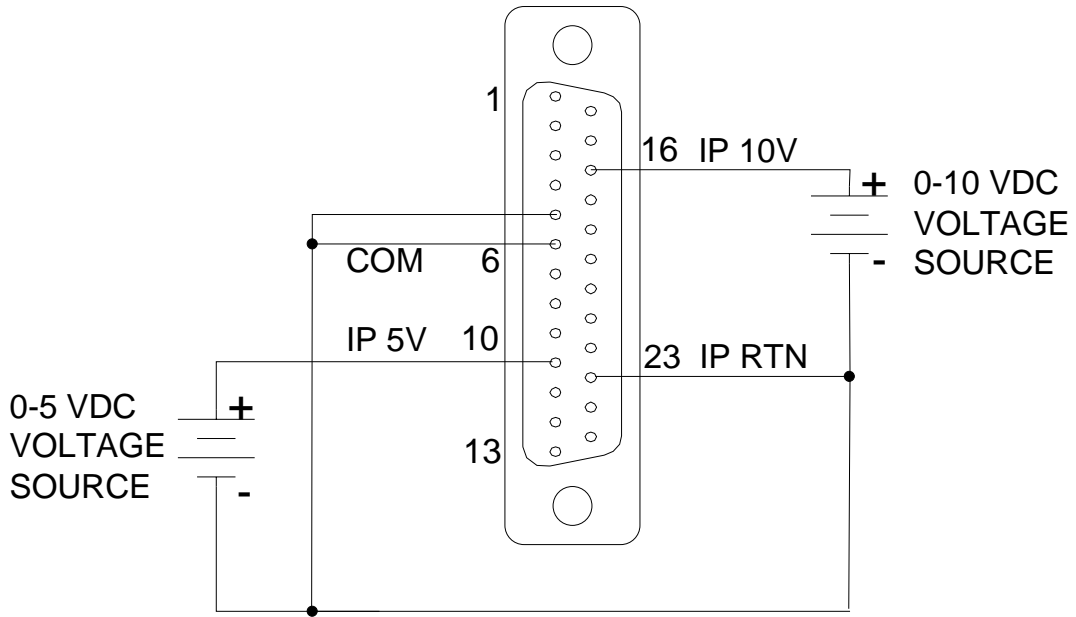

Figure 2-1
Remote Current Programming Using 0-5 or 0-10 VDC Source

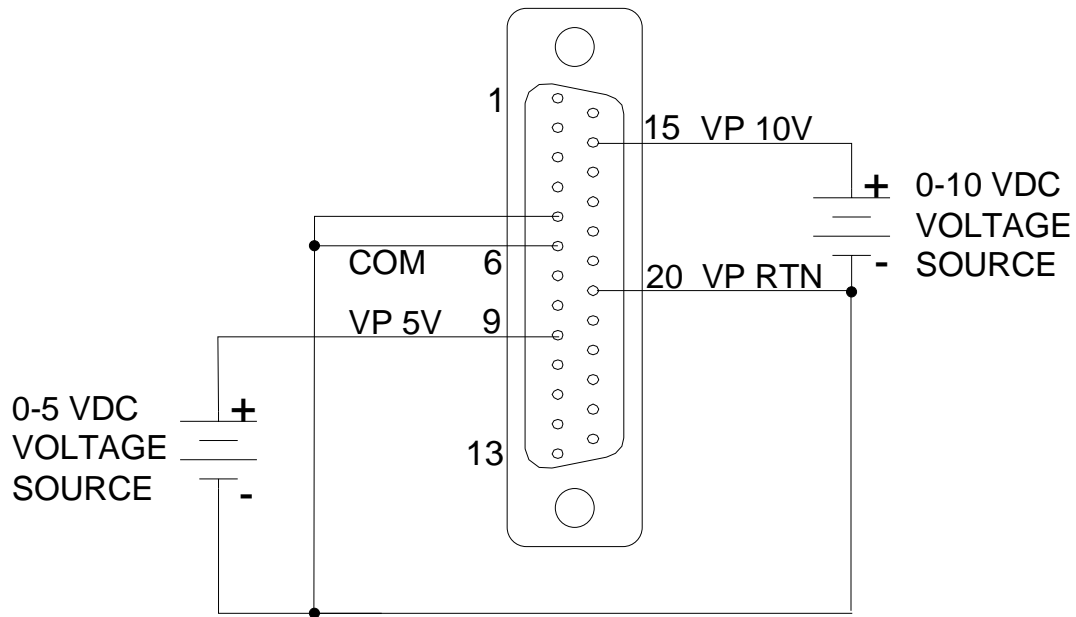

Figure 2-2
Remote Voltage Programming Using 0-5 or 0-10 VDC Source