



**Sorensen**  
**Internal Ethernet & RS-232**  
**Interface for XFR Series**  
**Programmable DC Power Supplies**  
**Operation Manual**

ENET-XFR  
ENET-XFR3



## **About AMETEK**

AMETEK Programmable Power, Inc., a Division of AMETEK, Inc., is a global leader in the design and manufacture of precision, programmable power supplies for R&D, test and measurement, process control, power bus simulation and power conditioning applications across diverse industrial segments. From bench top supplies to rack-mounted industrial power subsystems, AMETEK Programmable Power is the proud manufacturer of Elgar, Sorensen, California Instruments and Power Ten brand power supplies.

AMETEK, Inc. is a leading global manufacturer of electronic instruments and electromechanical devices with annualized sales of \$2.5 billion. The Company has over 11,000 colleagues working at more than 80 manufacturing facilities and more than 80 sales and service centers in the United States and around the world.

## **Trademarks**

AMETEK is a registered trademark of AMETEK, Inc. Sorensen is a trademark owned by AMETEK, Inc. Other trademarks, registered trademarks, and product names are the property of their respective owners and are used herein for identification purposes only.

## **Notice of Copyright**

*Internal Ethernet and RS-232 Interface for XFR Series Programmable DC Power Supplies Operation Manual* © 2007 AMETEK Programmable Power, Inc. All rights reserved.

## **Exclusion for Documentation**

UNLESS SPECIFICALLY AGREED TO IN WRITING, AMETEK PROGRAMMABLE POWER, INC. ("AMETEK"):

- (a) MAKES NO WARRANTY AS TO THE ACCURACY, SUFFICIENCY OR SUITABILITY OF ANY TECHNICAL OR OTHER INFORMATION PROVIDED IN ITS MANUALS OR OTHER DOCUMENTATION.
- (b) ASSUMES NO RESPONSIBILITY OR LIABILITY FOR LOSSES, DAMAGES, COSTS OR EXPENSES, WHETHER SPECIAL, DIRECT, INDIRECT, CONSEQUENTIAL OR INCIDENTAL, WHICH MIGHT ARISE OUT OF THE USE OF SUCH INFORMATION. THE USE OF ANY SUCH INFORMATION WILL BE ENTIRELY AT THE USER'S RISK, AND
- (c) REMINDS YOU THAT IF THIS MANUAL IS IN ANY LANGUAGE OTHER THAN ENGLISH, ALTHOUGH STEPS HAVE BEEN TAKEN TO MAINTAIN THE ACCURACY OF THE TRANSLATION, THE ACCURACY CANNOT BE GUARANTEED. APPROVED AMETEK CONTENT IS CONTAINED WITH THE ENGLISH LANGUAGE VERSION, WHICH IS POSTED AT [WWW.PROGRAMMABLEPOWER.COM](http://WWW.PROGRAMMABLEPOWER.COM).

## **Date and Revision**

February 2009 Revision F

## **Part Number**

TM-XR9B-01XN



## **Contact Information**

Telephone: 800 733 5427 (toll free in North America)  
858 450 0085 (direct)  
Fax: 858 458 0267  
Email: [sales@programmablepower.com](mailto:sales@programmablepower.com)  
[service@programmablepower.com](mailto:service@programmablepower.com)  
Web: [www.programmablepower.com](http://www.programmablepower.com)

This page intentionally left blank.

# Important Safety Instructions

Before applying power to the system, verify that your product is configured properly for your particular application.

 WARNING	<b>Hazardous voltages may be present when covers are removed. Qualified personnel must use extreme caution when servicing this equipment. Circuit boards, test points, and output voltages also may be floating above (below) chassis ground.</b>
 WARNING	<b>The equipment used contains ESD sensitive parts. When installing equipment, follow ESD Safety Procedures. Electrostatic discharges might cause damage to the equipment.</b>

Only *qualified personnel* who deal with attendant hazards in power supplies, are allowed to perform installation and servicing.

Ensure that the AC power line ground is connected properly to the Power Rack input connector or chassis. Similarly, other power ground lines including those to application and maintenance equipment *must* be grounded properly for both personnel and equipment safety.

Always ensure that facility AC input power is de-energized prior to connecting or disconnecting any cable.

In normal operation, the operator does not have access to hazardous voltages within the chassis. However, depending on the user's application configuration, **HIGH VOLTAGES HAZARDOUS TO HUMAN SAFETY** may be normally generated on the output terminals. The customer/user must ensure that the output power lines are labeled properly as to the safety hazards and that any inadvertent contact with hazardous voltages is eliminated.

Guard against risks of electrical shock during open cover checks by not touching any portion of the electrical circuits. Even when power is off, capacitors may retain an electrical charge. Use safety glasses during open cover checks to avoid personal injury by any sudden component failure.

Neither AMETEK Programmable Power Inc., San Diego, California, USA, nor any of the subsidiary sales organizations can accept any responsibility for personnel, material or inconsequential injury, loss or damage that results from improper use of the equipment and accessories.

## SAFETY SYMBOLS

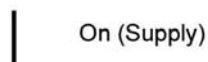
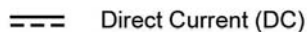
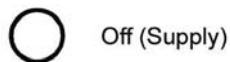
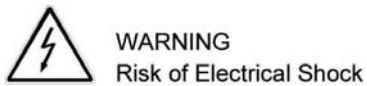

This page intentionally left blank.

## Product Family: Internal Ethernet and RS-232 Interface for XFR Series

Warranty Period: Five Years

### WARRANTY TERMS

AMETEK Programmable Power, Inc. ("AMETEK"), provides this written warranty covering the Product stated above, and if the Buyer discovers and notifies AMETEK in writing of any defect in material or workmanship within the applicable warranty period stated above, then AMETEK may, at its option: repair or replace the Product; or issue a credit note for the defective Product; or provide the Buyer with replacement parts for the Product.

The Buyer will, at its expense, return the defective Product or parts thereof to AMETEK in accordance with the return procedure specified below. AMETEK will, at its expense, deliver the repaired or replaced Product or parts to the Buyer. Any warranty of AMETEK will not apply if the Buyer is in default under the Purchase Order Agreement or where the Product or any part thereof:

- is damaged by misuse, accident, negligence or failure to maintain the same as specified or required by AMETEK;
- is damaged by modifications, alterations or attachments thereto which are not authorized by AMETEK;
- is installed or operated contrary to the instructions of AMETEK;
- is opened, modified or disassembled in any way without AMETEK's consent; or
- is used in combination with items, articles or materials not authorized by AMETEK.

The Buyer may not assert any claim that the Products are not in conformity with any warranty until the Buyer has made all payments to AMETEK provided for in the Purchase Order Agreement.

### PRODUCT RETURN PROCEDURE

1. Request a Return Material Authorization (RMA) number from the repair facility (**must be done in the country in which it was purchased**):
  - **In the USA**, contact the AMETEK Repair Department prior to the return of the product to AMETEK for repair:  
Telephone: 800-733-5427, ext. 2295 or ext. 2463 (toll free North America)  
858-450-0085, ext. 2295 or ext. 2463 (direct)
  - **Outside the United States**, contact the nearest Authorized Service Center (ASC). A full listing can be found either through your local distributor or our website, [www.programmablepower.com](http://www.programmablepower.com), by clicking Support and going to the Service Centers tab.
2. When requesting an RMA, have the following information ready:
  - Model number
  - Serial number
  - Description of the problem

**NOTE:** Unauthorized returns will not be accepted and will be returned at the shipper's expense.

**NOTE:** A returned product found upon inspection by AMETEK, to be in specification is subject to an evaluation fee and applicable freight charges.

This page intentionally left blank.



# About This Manual

## Purpose

This Operating Manual is for the XFR 1.2kW and 2.8kW Ethernet/RS-232 Interface Option; a microprocessor-controlled option card for all models of XFR Series DC output power supplies. This manual provides you with specifications, user options, and configuration instructions for the interface, along with a command set which allows you to control your power supply from a computer console. Error messages and calibration procedures are also included.

## Scope

This Operating Manual covers the interface only. Refer to your power supply manual for installation, configuration, and operating procedures for your power supply.

## Audience

This manual is designed for the user who is familiar with basic electrical theory especially as it applies to the operation of power supplies. This implies a recognition of Constant Voltage and Constant Current operation modes and the control of input and output power, as well as the observance of safe techniques while effecting supply or pin connections and any changes in switch settings. The user should also have experience with network-based communications software and protocols.

## Organization

This Manual is organized into 4 chapters and 2 appendixes.

**Chapter 1, “Features”** Describes the interface and lists its features.

**Chapter 2, “Installation and Configuration”** Explains basic setup procedures for Ethernet mode and RS-232 mode. Describes inspection, cleaning, shipping, and storage procedures.

**Chapter 3, “Operation”** Lists the complete command set, status registers, and error codes.

**Chapter 4, “Calibration”** Provides detailed procedures for voltage and current mode calibration as well as over voltage protection (OVP) calibration. Includes calibration for programming and readback accuracy.

**Appendix A, “Specifications”** Details the interface specifications.

**Appendix B, “Advanced Ethernet Administration”** Details how to change network password, view port statistics and interpret LED information.

**“Warranty and Product Information”** Explains Warranty and return information.

# Contents

<b>Important Safety Instructions</b> .....	vii
--	-----

## 1 Features

Description .....	1-1
Features and Functions .....	1-2
Interface Features .....	1-2
Ethernet Features .....	1-3
Programmable Functions .....	1-3
Readback Functions .....	1-3

## 2 Installation and Configuration

Introduction .....	2-1
Initial Inspection .....	2-3
Front Panel .....	2-4
Ethernet/RS-232 Interface Subplate and PCB .....	2-5
Changing Internal Jumpers .....	2-8
Procedure for 1.2kW XFR .....	2-8
Procedure for 2.8kW XFR .....	2-9
Basic Setup Procedure - Ethernet .....	2-10
Basic Setup Procedure - RS-232 .....	2-11
Configuring for Ethernet or RS-232 .....	2-12
Ethernet Communications .....	2-13
Ethernet Connection .....	2-13
Connecting to a Network .....	2-13
Connecting Directly to your Computer .....	2-13
Locating the Power Supply on Your Network .....	2-14
Configuring Ethernet Bridge .....	2-15
Installing and Using RealPort® .....	2-17
Background .....	2-17
Installation .....	2-17
Using RealPort® .....	2-18
RS-232 Communications .....	2-19
RS-232 Connection .....	2-19

Baud Rate Selection	2–20
Flow Control Selection	2–21
Remote/Local Operation	2–22
Remote/Local Mode Startup	2–22
Remote Mode Operation	2–23
Local Mode Operation	2–24
Remote Enable (REN) Command	2–24
Local Lockout (LLO) Command	2–25
Power Supply Settings	2–25
Additional User Options and Settings	2–26
OVP Selection	2–26
TTL Shutdown Polarity	2–27
User Signals	2–28
User Lines Connector	2–28
User Lines Cable Connection	2–30

### 3 Operation

Introduction	3–1
<b>RS-232</b> Operation	3–2
<b>Ethernet</b> Operation	3–2
Command Syntax	3–2
Manual Conventions	3–2
Command Format and Parameters	3–3
Floating Point Number <float>	3–4
Command Strings	3–5
Command Terminators	3–5
Order	3–5
Command Summary	3–6
Command Reference	3–9
Accumulated Status, Status, and Fault Registers	3–17
Error Codes	3–19
Troubleshooting	3–20
Diagnostic LEDs	3–20
Computer Operating Properly (COP) LEDs	3–20
<b>Ethernet</b> Mode Troubleshooting Tips	3–21
<b>RS-232</b> Mode Troubleshooting Tips	3–23
<b>RS-232</b> and/or <b>Ethernet</b> Mode Troubleshooting Tips	3–23

---

<b>4</b>	<b>Calibration</b>	
	Introduction	4-1
	Voltage Mode Calibration	4-3
	Voltage Calibration Setup	4-3
	Voltage Program Calibration Procedure	4-3
	Voltage Readback Calibration Procedure	4-4
	Current Mode Calibration	4-5
	Current Calibration Setup	4-5
	Current Program Calibration Procedure	4-5
	Current Readback Calibration Procedure	4-6
	Over Voltage Protection (OVP) Calibration	4-7
<b>A</b>	<b>Specifications</b>	
	Specifications for XFR 1.2kW with Ethernet/RS-232 Interface Installed	A-2
	Specifications for XFR 2.8kW with Ethernet/RS-232 Interface Installed	A-4
<b>B</b>	<b>Advanced Ethernet Administration</b>	
	Changing the Root Password	B-2
	Resetting the Configuration to Defaults	B-3
	Introduction	B-3
	Resetting the Configuration from a Browser	B-3
	Copying the Configuration to and from a Server	B-4
	Viewing Port Statistics and Settings	B-4
	Viewing Network Statistics	B-4
	Interpreting LED Information	B-5
	<b>Warranty and Product Information</b>	WA-1



# Figures

Figure 1-1	Sample configuration using <b>Ethernet/RS-232 Interface</b> (1200 Watt DC Power Supplies Shown) -----	1-2
Figure 2-1	Power Supply Front Panel with <b>Ethernet/RS-232 Interface</b> Installed (1200 Watt Power Supply Shown) -----	2-4
Figure 2-2	<b>Ethernet/RS-232 Interface</b> Subplate -----	2-5
Figure 2-3	<b>Ethernet/RS-232 Interface</b> PCB -----	2-6
Figure 2-4	Removing the PCB-----	2-8
Figure 2-5	RS-232 Connector Pinouts-----	2-19
Figure 2-6	User Lines Signal Connector Circuit Block Diagram -----	2-29
Figure 2-7	User Lines Cable with Ferrite Block -----	2-30
Figure 4-1	Voltage Calibration Setup -----	4-3
Figure 4-2	Current Calibration Setup -----	4-5
Figure B-1	Ethernet Bridge LEDs-----	B-5





# Tables

Table 2-1	Remote Programming LEDs	2-4
Table 2-2	<b>Ethernet/RS-232 Interface</b> Jumper Selections	2-7
Table 2-3	<b>Ethernet</b> Setup Procedure	2-10
Table 2-4	<b>RS-232</b> Setup Procedure	2-11
Table 2-5	Jumper positions for <b>Ethernet</b> or <b>RS-232</b>	2-12
Table 2-6	Jumper J2 Settings for Baud Rate	2-20
Table 2-7	Jumper J2 Flow Control Section	2-21
Table 2-8	Jumper J2 Flow Control Protocol Selection	2-21
Table 2-9	Jumper J2 Remote/Local Start-up Settings	2-22
Table 2-10	Remote Mode Power On Conditions	2-23
Table 2-11	Power Supply Settings	2-25
Table 2-12	OVP Control Mode Selection	2-26
Table 2-13	Jumper Settings for TTL Shutdown Circuit Logic	2-27
Table 2-14	User Signals Connector	2-28
Table 3-1	Command Parameters	3-4
Table 3-2	Floating Point Numbers	3-4
Table 3-3	Programming Commands	3-6
Table 3-4	Query Commands	3-7
Table 3-5	Calibration Commands	3-8
Table 3-6	Status Commands	3-8
Table 3-7	Command Reference	3-9
Table 3-8	Accumulated Status, Status and Fault Registers	3-18
Table 3-9	Error Codes	3-19
Table 3-10	<b>Ethernet</b> Mode Tips	3-21
Table 3-11	<b>RS-232</b> Mode Tips	3-23
Table 3-12	<b>RS-232</b> and/or <b>Ethernet</b> Mode Tips	3-23
Table A-1	XFR 1.2kW 7.5 V to 40 V	A-2
Table A-2	XFR 1.2kW 60 V to 600 V	A-3
Table A-3	XFR 2.8kW 7.5 V to 40 V	A-4
Table A-4	XFR 2.8kW 60 V to 600 V	A-5
Table B-1	Ethernet Bridge LEDs Interpretation	B-5



# 1

## Features

### Description

The Ethernet/RS-232 Interface is a microprocessor-controlled option card for all models of the XFR series of DC output power supply. Installed internally, the interface card allows you to remotely control your power supply through your existing network, or via a direct connection to your computer. It features an auto-sensing 10/100Base-T network interface that provides fast programming and readback utilizing an extensive command set. You are able to select between Ethernet (factory default) or RS-232 control by adjusting internal jumpers on the interface card.

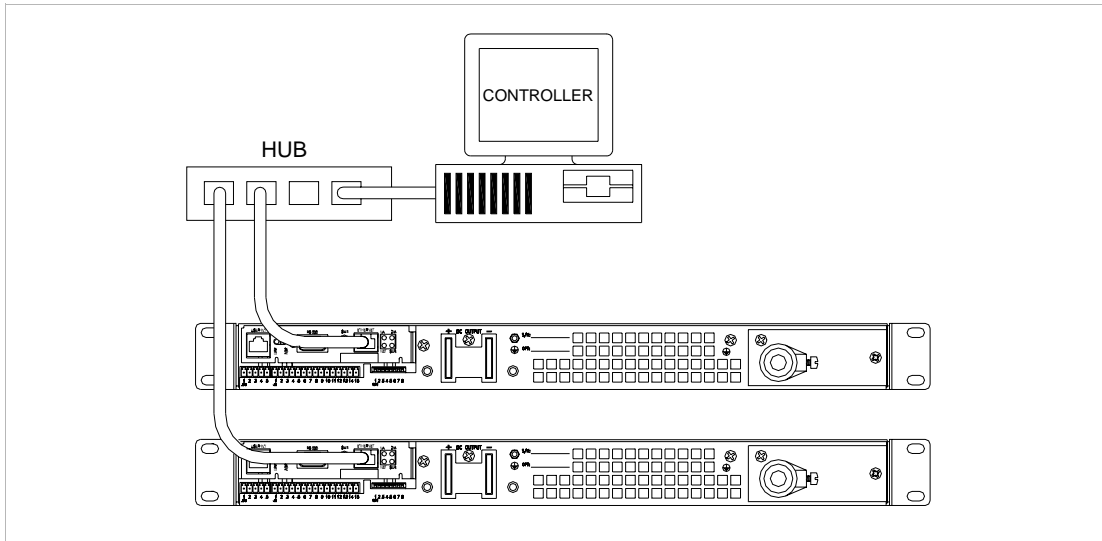

**Figure 1-1** Sample configuration using **Ethernet/RS-232 Interface**  
(1200 Watt DC Power Supplies Shown)

## Features and Functions

### Interface Features

- Programmable soft limits for voltage and current
- Programmable over voltage protection with reset
- Easy-to-use, self-documenting command set
- Standardized commands for complete communication with any of the supplies in the system
- User-programmable isolated fault, polarity, isolation, and auxiliary, user-defined output signals.
- LED status signals: error, address, remote/local operation, and over voltage protection.
- Foldback in CV or CC mode with reset
- Software calibration

## Ethernet Features

- Auto-sensing 10/100Base-T network interface
- Robust onboard TCP/IP stack supports:
  - TCP/UDP
  - UDP Multicast
- Universal IP Address Assignment via:
  - DHCP
  - RARP
  - ARP-Ping
- Easy configuration via web browser (HTTP)
- RealPort® COM/TTY port redirection software
- Status LEDs for Link, Activity, and Diagnostics
- Reset switch to reboot Ethernet Bridge

## Programmable Functions

- Output voltage and current
- Soft limits for voltage and current
- Over voltage protection
- Output enable/disable
- Maskable fault interrupt
- Hold and trigger
- Output relay signals

## Readback Functions

- Actual voltage and current
- Voltage and current settings
- Soft voltage and current limits
- Over voltage protection setting
- Present and accumulated power supply status
- Programming error codes
- Fault codes
- Power supply model and software version identification



# 2

## Installation and Configuration

### Introduction

The Ethernet/RS-232 Interface is usually installed at the factory. Your local distributor or service center can also install the interface, especially for use in a previously-purchased supply already on site. You must then configure the Interface-enhanced supply for your system using the [“Basic Setup Procedure - Ethernet”](#) on page 2–10, or the [“Basic Setup Procedure - RS-232”](#) on page 2–11.

To use this product, you must have the following equipment:

- a Xantrex XFR DC output power supply
- computer-based communications software package

Also, depending on your specific configuration, you will need additional items.

For Ethernet (via network):

- CAT 5 network cable to connect XFR to your network
- computer connected to the network

For Ethernet (direct to computer):

- CAT 5 crossover cable to connect XFR directly to your computer
- computer with network interface card (NIC)

For RS-232:

- null modem serial cable (cross over)
- computer with an RS-232 interface (serial/COM port)



## Initial Inspection



### CAUTION

If you remove the unit's cover, use proper static control techniques to avoid damage to static-sensitive components on the printed circuit board.

---

On first receiving your unit, perform a quick physical check.

- Ensure each package contains a power supply with its Ethernet/RS-232 Interface board installed, and manuals for the power supply and the Ethernet/RS-232 Interface. Any additional parts shipped with the power supply will be identified in the supply's documentation.
- Inspect the unit for any signs of physical damage such as scratches, cracks, or broken switches, connectors, or displays.
- Check the printed circuit board and components if you suspect internal damage.

If the unit is damaged, save all packing materials and notify the carrier immediately. For additional information, please see the section titles, "Returning Power Supplies to the Manufacturer" in the manual shipped with your complete unit.

---



### CAUTION

Use proper static control techniques to avoid damage to static-sensitive components on the printed circuit board.

---

## Front Panel

Figure 2-1 shows the front panel of an XFR 1200 Watt supply with Ethernet/RS-232 Interface installed. There is a further description of the Remote Programming LEDs in Table 2-1.

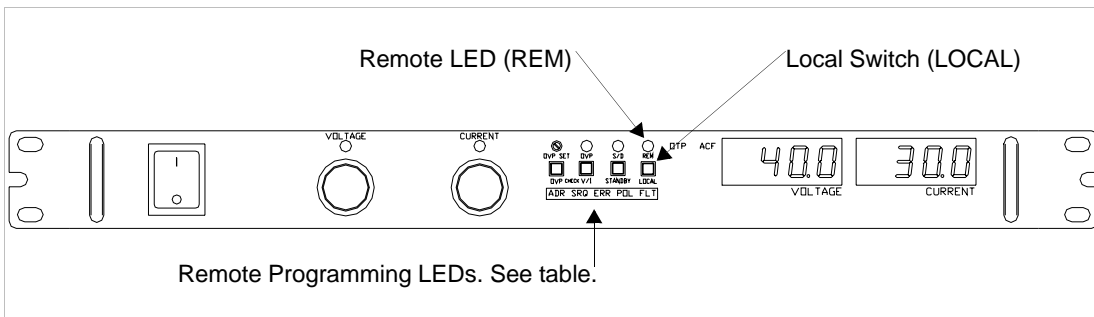

**Figure 2-1** Power Supply Front Panel with Ethernet/RS-232 Interface Installed (1200 Watt Power Supply Shown)

**Table 2-1** Remote Programming LEDs

LED	Description
ADR	Address: Indicates that the master controller is addressing the unit.
SRQ	Service Request: (GPIB only)
ERR	Error: Indicates when a programming error has occurred. You can clear the ERR LED with an error query command.
FLT	Fault: Indicates that a fault has occurred. The fault bit must be unmasked. Refer to the status register in Table 3-8 on page 3-18. Momentarily lights if PON SRQ is set to on.
POL	Polarity: Indicates that the polarity user line has been activated. See “User Lines Connector” on page 2-28.

## Ethernet/RS-232 Interface Subplate and PCB

The Ethernet/RS-232 Interface Subplate is visible from the rear panel of the unit. Rear panel components are identified in [Figure 2-2](#).

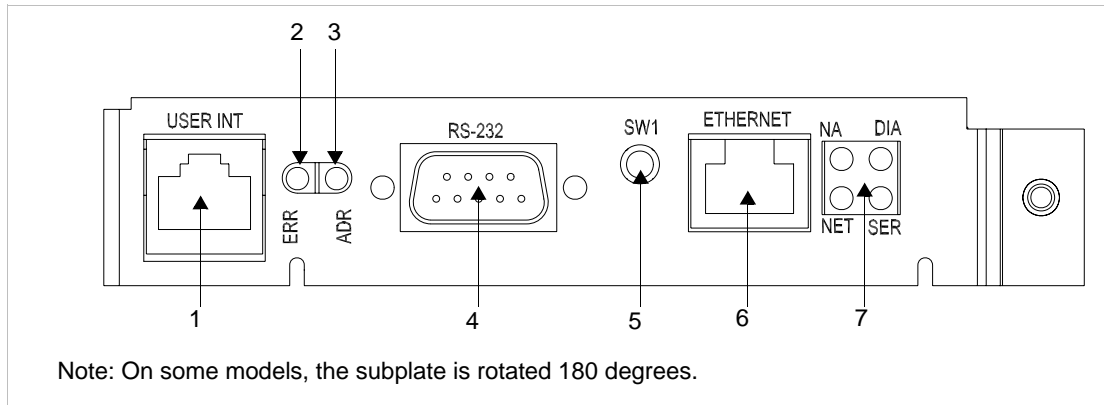

**Figure 2-2 Ethernet/RS-232 Interface Subplate**  
(XFR 1.2kW shown - located on power supply rear cover)

Item	Description
1	User Lines Signal Connector
2	Error LED (ERR) Indicates that a programming error has occurred. Clear with error query command.
3	Address LED (ADR) Indicates that the unit is being addressed by the master controller.
4	RS-232 Connector
5	Ethernet Bridge Reset Switch
6	RJ45 Ethernet Connector
7	Ethernet Bridge LEDs NA: Reserved DIA: Diagnostics NET: Network link status SER: Serial port activity See <a href="#">page 5-5</a> .



**Table 2-2 Ethernet/RS-232 Interface Jumper Selections**

JUMPER SELECTION			
J2	Baud rate selection (default 9600)	<a href="#">page 2-20</a>	B1 (5-6) [closed] [default] B2 (3-4) [closed] [default] B3 (1-2) [closed] [default]
J2	RS-232 flow control selection hardware (RTS/ CTS) or software (XON/ XOFF)	<a href="#">page 2-21</a>	FLW (7-8) [closed] [default] Flow control disabled. FLW (7-8) [open] Flow control enabled. XON (9-10) [closed] [default] Hardware flow control. XON (9-10) [open] Software flow control.
J2	Unused		(11-12) [closed] [default] Provides extra jumper. (13-14) [open] Not used.
J2	Power-On remote/local	<a href="#">page 2-22</a>	PONREM (15-16) [open] [default] PON in remote. PONREM (15-16) [closed] PON in local.
J3, J4, J5, J6	Ethernet or RS232 mode	<a href="#">page 2-12</a>	(2-3) [default] Ethernet. (1-2) RS232.
J65	Local OVP control selection	<a href="#">page 2-26</a>	[closed] [default] [open] Front Panel OVP Control.
J93	User TTL shutdown (S/D) selection	<a href="#">page 2-27</a>	(1-2) User TTL S/D line active low. (2-3) [default] User TTL S/D line active high.
J103	Remote OVP control selection	<a href="#">page 2-26</a>	[closed] [default] [open]
Note: All other jumpers are not user-selectable.			
LED INDICATORS			
CR89 Red Diagnostic LED Bus error or Soft restart on Master circuitry CR166 Red Diagnostic LED Soft restart on Master circuitry CR167 Green Diagnostic LED Bus error on Master circuitry Refer to <a href="#">“Troubleshooting” on page 3-20</a> for more information on these LEDs.			
EPROMS			
Slave EPROM See revision number stamped on EPROM Master EPROM See revision number stamped on EPROM			

## Changing Internal Jumpers

Some of the settings on the Ethernet/RS-232 Interface card are user selectable by way of jumpers on the printed circuit board. The procedure for changing the jumpers varies depending on if you have a 1.2kW XFR, or a 2.8kW XFR.



### CAUTION

If you remove the unit's cover, use proper static control techniques to avoid damage to static-sensitive components on the printed circuit board.

---

### Procedure for 1.2kW XFR

Ensure that the input power connection has been disconnected and the unit is powered off before you attempt to remove the top cover. Remove all the screws holding down the top cover and then remove the cover. The printed circuit board that you need access to is upside down (component side down), so you must remove all the screws that are holding it in place. Refer to [Figure 2-4](#) to see which screws should not be removed.

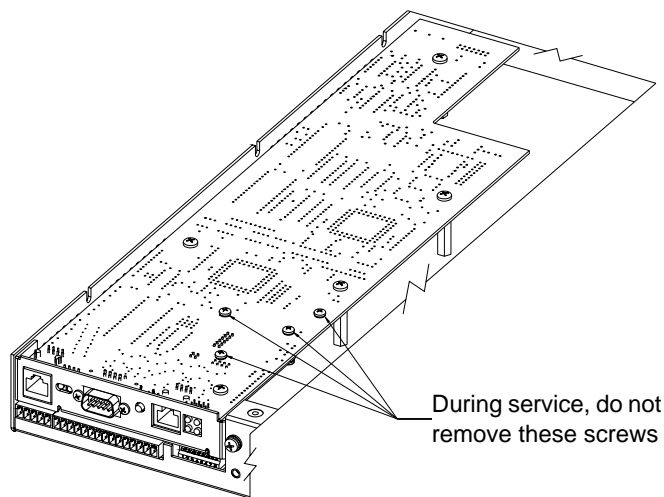

Figure 2-4 Removing the PCB

Once that is complete, turn the board over and, if necessary, remove the short ribbon cable connected to J64 on the interface card to get access to the under side of the PCB. You can now scan the board and refer to [Figure 2-3](#) to locate the various components and jumpers on the PCB. Once you have made the necessary changes, reconnect the ribbon cable, screw the PCB back in place, and screw the top cover on.

### **Procedure for 2.8kW XFR**

Ensure that the input power connection has been disconnected and the unit is powered off before you attempt to remove the top cover. Remove all the screws holding down the top cover and then remove the cover. The printed circuit board that you need access to is right side up (component side up), so refer to [Figure 2-3](#) to locate the various components and jumpers on the PCB. Once you have located the jumpers and made the necessary changes, return the top cover to its proper position, and screw it back in place.

## Basic Setup Procedure - Ethernet

This procedure can be used as a quick reference for those familiar with the configuration requirements for the Ethernet/RS-232 Interface as installed in the DC power supply. For those who want more information, each step refers to more detailed procedures located in subsequent sections. Execute each step of the procedure in the sequence given.

**Table 2-3 Ethernet Setup Procedure**

Step #	Description	Action	Reference
1	Mode Configuration	Configure for <b>Ethernet</b> communications.	See “Configuring for Ethernet or RS-232” on page 2–12.
2	Ethernet Connection	Connect the CAT 5 network cable to the Ethernet connector on the supply.	See “Ethernet Connection” on page 2–13.
3	User Signal Connector	Configure and use the user line connector signals, if required.	See “User Lines Connector” on page 2–28.
4	Power ON	Power on the unit and wait 45 seconds for the Ethernet Bridge to complete its start-up routine. Before proceeding, check to ensure that the green NETWORK LED on the back panel is ON.	See “Troubleshooting” on page 3–20 if the NETWORK LED does not stay illuminated after startup has completed.
5	Locate your power supply on your network	Load the Setup Software that ships with this interface card.	See “Locating the Power Supply on Your Network” on page 2–14.
6	Configure the Ethernet Bridge	Access the device’s web server/ configuration page.	See “Configuring Ethernet Bridge” on page 2–15.
7	Test	Begin Communicating with your instrument.	If you do not have a TCP/IP based software application suitable for this application, and are familiar with RS-232 type communications, see “Installing and Using RealPort®” on page 2–17.



## Basic Setup Procedure - RS-232

This procedure can be used as a quick reference for those familiar with the configuration requirements for the Ethernet/RS-232 Interface as installed in the DC power supply. For those who want more information, each step refers to more detailed procedures located in subsequent sections. Execute each step of the procedure in the sequence given.

**Table 2-4 RS-232 Setup Procedure**

Step	Description	Action	Reference
1	Mode Configuration	Configure for <b>RS-232</b> communications.	See “Configuring for Ethernet or RS-232” on page 2–12.
2	Baud Rate Selection	Select transmission speed. (Default 9600)	See “Baud Rate Selection” on page 2–20.
3	Flow Control Selection	Select flow control ON or OFF. (Default is OFF) If flow control is set ON, choose software-based XON/XOFF or hardware-based RTS/CTS communication control.	See “Flow Control Selection” on page 2–21.
4	Remote/Local Operation	The factory default is PON REM.	See “Remote/Local Operation” on page 2–22.
5	RS-232 Connection	Connect the RS-232 cable assembly to the RS232 connector on the supply.	See “Power Supply Settings” on page 2–25
6	User Signal Connector	Configure and use the user line connector signals, if required.	See “User Lines Connector” on page 2–28.
7	Power ON	Power on the unit.	See “Additional User Options and Settings” on page 2–26 and “User Signals” on page 2–28 for information about Local/Remote OVP, TTL Shutdown, and auxiliary connector user signals.
8	Power Supply Settings	Configure the controller’s operating parameters to match the power supply settings.	See “Power Supply Settings” on page 2–25.
9	Test	Test the link by communicating with the power supply.	Example: VSET2;ISET1 This command string sets power supply voltage to 2V and its current limit to 1A. See “Operation”.

## Configuring for Ethernet or RS-232

This interface card can be configured for Ethernet communication, or for RS-232 communication, but not both simultaneously. From the factory, the instrument will be configured for Ethernet communication. Therefore you should only need to follow these instructions if you are switching over to RS-232, or back to Ethernet. To switch between the two configurations, you must change internal jumpers on the interface card. See [“Changing Internal Jumpers” on page 2–8](#). Also refer to [Table 2-2](#) and [Figure 2-3 on page 2–6](#) to locate the corresponding jumpers.

**Table 2-5** Jumper positions for **Ethernet** or **RS-232**

Jumper	RS-232	Ethernet
J3	1-2	2-3
J4	1-2	2-3
J5	1-2	2-3
J6	1-2	2-3

When you have finished changing the jumper positions, ensure that the baud rate, flow control, and power-on state are configured properly for your new setup. These settings are also changed by adding or removing jumpers, so it is best to perform this adjustment, if necessary, while the interface card is accessible. Refer to [“Baud Rate Selection” on page 2–20](#), [“Flow Control Selection” on page 2–21](#) and [“Remote/Local Mode Startup” on page 2–22](#) for more detailed information on how to reconfigure these settings.

---

**Note:** If you are switching the interface card back to Ethernet it is recommended to set the baud rate to 9600, turn flow control off, and have the unit power-on in remote mode (these are the default settings).

---

# Ethernet Communications

## Ethernet Connection

There are two options for controlling your XFR power supply via Ethernet - "Connecting to a Network" or "Connecting Directly to your Computer." The first option is to connect the power supply to a network, and control the unit from your computer which is also connected to the network. The second option is to connect the XFR directly to your computer's network interface card (NIC). This bypasses the need for an existing network.

### Connecting to a Network

All that is required to connect your XFR to a network is a straight through CAT 5 network cable and an available network port.

### Connecting Directly to your Computer

To connect your XFR directly to your computer you will need a cross-over CAT 5 network cable. You will also need to check your network settings on your computer to ensure that you are using a static IP address. Check with your IT department for assistance.

## Locating the Power Supply on Your Network

1. Record the MAC address for your power supply. This will be visible at the back of the XFR, on the interface card subplate. For example,

MAC Address 00429D 22EF45
------------------------------

MAC Address:

---

2. Insert the Xantrex XFR Ethernet Software Utilities CD into your CD drive.
3. If the CD does not start automatically, double-click the *My Computer* icon, double-click the CD icon and then double-click *autorun\_main.htm*.
4. When the menu appears, click *Xantrex Device Discovery* to install and run the application. This application will find and list all XFR's with an Ethernet/RS-232 Interface card on your network.
5. You can now scan the list and locate your new XFR by its MAC address.
6. If your network uses a DHCP server and DHCP was enabled on the XFR, your new instrument will already have an IP address. If not, you will have to configure an IP address manually. Refer to steps 2 and 3 in [“Configuring Ethernet Bridge”](#) on page 2–15 for more information.
7. Write down the IP address so that you can access the instrument via its web server, and for when you start communicating with the power supply.

---

## Configuring Ethernet Bridge

The Ethernet/RS-232 Interface card has an Ethernet Bridge that converts the ethernet packets to serial data signals for processing by the embedded microcontroller. The Ethernet Bridge must be properly configured for serial communications with the microcontroller. For example, settings on the Bridge, such as Baud Rate and Flow Control, must match the jumper settings on the interface board.

There are three ways to gain access to the configuration menu for the Ethernet Bridge: the Setup program that's on the Software CD; configure through a web browser; configure with the ARP Ping command. The **Setup program** will find your instrument and allow you to configure it by clicking on the instrument's IP address. You will then need to enter the correct username and password to be able to configure the device.

Default Username: root

Default Password: dbps

The **web browser** method is to open up a web browser like Internet Explorer, and type in the IP address for the instrument. Again, you will be asked for the username and password. Once you have accessed the configuration page, follow these steps for proper setup.

1. Click *Configuration > Serial Port*, and ensure that the following settings have been selected:
  - Baud Rate: 9600
  - Data Bits: 8
  - Parity: None
  - Stop Bits: 1
  - Flow Control: NoneClick *Apply* once you have finished adjusting the above settings.
2. Now click *Configuration > Network*. If your network uses a DHCP server (ask your IT department) you should select *Obtain IP address automatically using DHCP* and then click *Apply*. If your network doesn't use a DHCP server, select *Use the following IP address:* and enter an appropriate IP address, Subnet Mask and Default Gateway. .
3. Ask for assistance from your IT department to obtain an appropriate IP address, Subnet Mask, Default Gateway, Name Server, and Domain. Once you have made the appropriate changes, click *Apply*. If this changed the setting, the device will reboot, so you will have to renew your connection to its configuration webpage for any further configuration changes.

The **ARP Ping** command is done with the windows command line. To configure with ARP ping, first:

- See that there is no DHCP server running; then ensure that you've connected the device server to the network and that it is powered up.
- Make sure that your PC is on the same LAN as the device server. Or directly connected via a crossover cable.
- You also must not have an IP address already configured.

Once the preceding requirements are met, access the command prompt to enter your inputs (in Microsoft Windows, click the Start button and click Run...; in the Open: field, type cmd and click OK):

1. On the Command line, type: arp -s followed by the desired IP address and the MAC address of the device server, into your PC's Address Resolution Protocol (ARP) table.

E.g., **arp -s [ip\_address mac\_address];**

this might look like: arp -s 192.168.2.2 00-40-9D-00-00-00

Consult your system administrator for proper IP address configuration. The PC should be in static IP mode with a Class B default subnet mask of 255.255.0.0 just as the instrument is. Then the first two numbers of the instrument's IP should match that of the PC. To read your PC's IP configuration, type ipconfig at the command prompt.

Or go to the Internet Protocol TCP/IP window to modify the settings.

Access that window as follows:

- a. navigate to the Network Connections window for your computer
  - b. right click "Local Area Connection" and select Properties;
  - c. in the Local Area Network Connections window, select (highlight) the Internet Protocol TCP/IP item and click the Properties button.
2. Use the ping command to ping the device with the IP address just assigned.  
E.g., ping 192.168.2.2
  3. If the ping times out before there is a response from the device server, wait a few seconds and send the ping again. When the device server responds, it will indicate that the IP address has been configured. However, this is temporary; when the system reboots, the instrument will default back to DHCP mode unless this configuration is saved!

To save the newly configured IP address:

1. From a Web browser, type: **http://[IP address]**, in the address field and click GO or tap the Enter key; the instrument's Web interface will open. The default user name is "root" and password is "dbps".
2. In the unit's Web interface, click Configuration > Network, select Use the following IP address: and enter/verify the IP address that you assigned with the arp -s command; also enter the appropriate Subnet Mask and Default Gateway.
3. Once you have entered the information, click the Apply button. Then select "Reboot" and follow the instructions in the instrument's Web interface.

Alternately, you can use the discovery tool to save the network configuration.

## Installing and Using RealPort®<sup>1</sup>

### Background

RealPort® software allows you to keep using your existing applications that rely on COM ports and RS-232 links for communication purposes, instead of having to develop TCP/IP based network applications. Installed on a network-enabled PC, RealPort® creates a virtual COM port. As such, your application still thinks it is working with a real serial port, such as COM1. When the application sends data to this serial port, RealPort® ships the data across the network to the Ethernet Bridge in your power supply. By doing this, the network is transparent to your existing application.

### Installation

RealPort® can be installed on any PC running Windows NT 4.0, Windows 2000, or Windows XP.

1. Insert the Xantrex XFR Ethernet Software Utilities CD into your CD drive
2. If the CD does not start automatically, double-click the *My Computer* icon, double-click the CD icon and then double-click *autorun\_main.htm*.

---

<sup>1</sup>RealPort® is a registered trademark of Digi International.

## Installation and Configuration

---

3. When the menu appears, click *Digi RealPort®*.
4. Follow the on-screen instructions for proper installation.

---

**Note:** RealPort® drivers for UNIX systems are available. Contact your Xantrex representative to obtain these drivers if necessary.

---

## Using RealPort®

Once you have installed the RealPort® driver for your power supply, using it is as simple as running your existing application (such as HyperTerminal, or a custom RS-232 application) and setting the COM port to be the one created by the RealPort® driver for your instrument.



## RS-232 Communications

### RS-232 Connection



#### WARNING

Do not operate the power supply and the computer at significantly different frame potentials. The interface connection system may not be capable of handling the resulting excessive ground currents.

Use an approved RS-232 connector and null modem cable when connecting the Ethernet/RS-232 Interface to your computer. The RS-232 connector uses the 9 pin mating connector on the rear panel. [Figure 2-5](#) shows the pinouts for the RS-232 connector.

Refer to [Figure 2-2 on page 2-5](#) for the position of the RS-232 connector on the rear panel subplate.

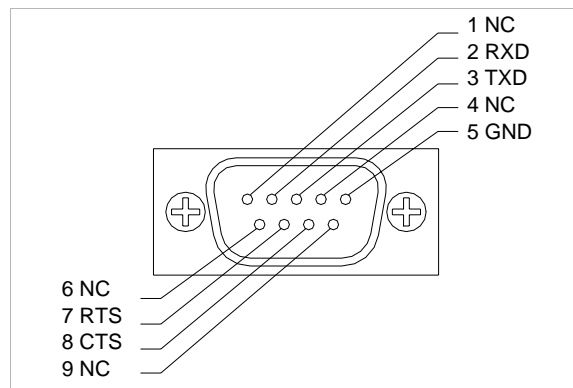

Figure 2-5 RS-232 Connector Pinouts

## Baud Rate Selection

Serial transmission sends and receives data in bit streams at fixed bit rates. Both the computer and the interface must have the same bit rate setting for proper communication. The default baud rate is 9600. We recommend that you do not change this setting. If the setting must be changed, use [Table 2-6](#) to select the correct jumper positions. You will need to remove the cover to change any jumpers. See [“Changing Internal Jumpers”](#) on page 2–8.

**Table 2-6** Jumper J2 Settings for Baud Rate

Baud Rate	B3	B2	B1
9600	closed	closed	closed
4800	open	closed	closed
2400	closed	open	closed
1200	open	open	closed
600	closed	closed	open
300	open	closed	open
150	closed	open	open
75	open	open	open

## Flow Control Selection

Flow control signals regulate data flow for proper communication. To enable or disable the flow control, change the J2 FLW jumper according to [Table 2-7](#). With flow control enabled, you can use either software or hardware protocols to control flow rates. You will need to remove the cover to change any jumpers. See [“Changing Internal Jumpers” on page 2–8](#).

**Table 2-7** Jumper J2 Flow Control Section

J2 FLW Jumper Setting	Condition
closed (default)	Disable Flow Control
open	Enable Flow Control

Once flow control is enabled, two flow control methods are available. You can select software based XON/XOFF flow protocol or hardware based RTS/CTS by changing an internal jumper. [Table 2-8](#) shows the flow control conditions with regards to the J2 XON jumper.

**Table 2-8** Jumper J2 Flow Control Protocol Selection

J2 XON Jumper Setting	Condition
closed (default)	Hardware Flow Control (RTS/CTS protocol)
open	Software Flow Control (XON/XOFF protocol)

## Remote/Local Operation

### Remote/Local Mode Startup

The power supply can be set to start-up in remote or local mode. To change this setting, the PON REM jumper must be adjusted according to [Table 2-9](#). You will need to remove the cover to change any jumpers. See “[Changing Internal Jumpers](#)” on [page 2-8](#) for information on how to change internal jumper settings.

See [Table 2-9](#) for the switch settings.

**Table 2-9** Jumper J2 Remote/Local Start-up Settings.

J2 PON REM Jumper Setting	Power ON results
open (default)	Unit in remote mode
closed	Unit in local mode

With the PON REM jumper open, the power supply will start up in remote mode. The green REM LED on the front panel will be lit, signaling that the power supply is under the control of the digital interface card. The output of the power supply is active on startup. To promote load safety, power ON defaults are zero for the output voltage and current limit, and 110% of maximum output voltage for the OVP trip point. See [Table 2-10](#). Refer to “[Operation](#)” for more information about the interface commands listed in the table.

If the PON REM jumper is closed, the power supply will power up in local mode. Power supply control is at the front panel. During an operating session, you can toggle between local mode and remote mode by using the front panel LOCAL button or sending commands as described in [Table 2-10](#).

---

**Note:** The default setting for this jumper is open. If you require it to be closed (PON in local mode) you can obtain a spare jumper by removing the one that connects pins 11 and 12 on J2 as these pins are unused.

---

**Table 2-10** Remote Mode Power On Conditions

Condition	Default Settings	7.5-140 Model Example
Voltage	0 V	VSET 0
Current	0 A	ISET 0
Soft Voltage Limit	VMAX (see models)	VMAX 7.5
Soft Current Limit	IMAX (see models)	IMAX 140
OVP Trip Voltage	Model VMAX + 10%	OVSET 8.25
Delay	0.5 s	DLY 0.5S
Remote Enable	ON	REN ON
Foldback Protection	OFF	FOLD OFF
Output	ON	OUT ON
Hold	OFF	HOLD OFF
Unmask	NONE	UNMASK NONE
AUXA	OFF	AUXA OFF
AUXB	OFF	AUXB OFF

## Remote Mode Operation

While in remote mode, use the interface commands to control the output of the power supply from a computer. See “Operation” for a complete list of device-dependent commands available with this interface.

From remote mode, change to local mode operation by pressing the front panel LOCAL button or by sending either the GTL command or the REN OFF command. You can disable the LOCAL button by using the LLO command. For an example of how to use Local Lockout, see “[Local Lockout \(LLO\) Command](#)” on page 2–25.

To return to remote mode, ensure that the REN command is set to ON and then send any valid device-dependent command. Since the remote mode output settings may be different from the local mode settings, the output is programmed to protect the load by turning off when you toggle from local to remote mode during a session. Check your remote settings and then send OUT ON to restore the output.

## Local Mode Operation

In local mode operation, you set the voltage and current output levels and the OVP trip level with controls located on the front panel. Refer to the operating manual for a description of the functions available at the front panel.

While in local mode operation, you can change power supply control to remote mode by ensuring that REN is ON, then sending any software command and OUT ON to restore the output. Return to local mode by pressing the front panel LOCAL button, unless Local Lockout is in effect. If LLO is in effect, use the GTL command to send the power supply into local mode, or use the REN OFF command to turn off LLO and return the power supply to local mode.

### Example:

Press the LOCAL button	Set unit to local mode
Id?	Put the unit into remote mode (Use any command to do this.)
Press the LOCAL button	Return to local mode.

## Remote Enable (REN) Command

You can use the Remote Enable command to toggle between local mode and remote mode. The default setting at startup is REN ON. With the remote enable command set at REN ON, you can return the power supply to remote mode whenever you send any command from the computer. Any time that you change from local to remote mode during a session, the output is programmed to turn off, since the remote mode settings may be different from the local mode settings. Send the OUT ON command to restore the output.

You can turn off Remote Enable and move power supply control to the front panel by sending the REN OFF command. If the Local Lockout condition is in effect, sending the REN OFF command will turn off the LLO condition before sending the unit into local mode.

To check whether the power supply is remote enabled, use the REN? query command.

### Example:

REN ON	Enable the power supply to be sent into remote mode
VSET 10;ISET 2	Put the unit into remote operation mode (Use any command to do this.)

## Local Lockout (LLO) Command

Use the Local Lockout command to disable the LOCAL button on the power supply front panel. With LLO in effect, you cannot return to local control by pressing the front panel LOCAL switch. You can still return to local mode by sending the Go to Local (GTL) command. However, to turn off LLO and return the power supply to local mode, send the REN OFF command. Only the REN OFF command will remove the LLO condition.

### Example:

LLO	Set Local Lockout
GTL	Return the power supply to local mode. Local Lockout is still in effect
REN OFF	Turn off Local Lockout and return the power supply to local mode

## Power Supply Settings

For serial communication, the computer and the Ethernet/RS-232 Interface must share the same communication settings. Make sure that the settings of the computer and of the power supply agree with those shown in [Table 2-11](#).

**Table 2-11** Power Supply Settings

Parameter	Setting
Transmission	Asynchronous
Mode	Full Duplex
Speeds	75, 150, 300, 600, 1200, 2400, 4800, 9600 (default)
Parity	None
Connector	DB9-pin Male
Start Bit	1
Stop Bit	1
Data Bits	8
Protocols	XON/XOFF RTS/CTS NONE (default)

## Additional User Options and Settings

You can customize remote operation settings for OVP (over voltage protection) control and TTL shutdown by changing jumper positions on the Ethernet/RS-232 Interface card. Refer to the operating manual for information on how to use over voltage protection and TTL shutdown.

### OVP Selection

Over voltage protection (OVP) on the Ethernet/RS-232 Interface is set at the factory for remote software operation. When operating the power supply in remote mode, you control the OVP trip level using the OVSET software command. If you return the power supply to local operation by using the REN software command or the front panel LOCAL switch, control of the OVP trip level changes from software control to the front panel OVP potentiometer. The default OVP trip level is set as 110% of the power supply's rated output voltage. See [Table 2-10 on page 2-23](#) for a complete list of remote power ON default settings.

You can isolate the location of OVP control by changing the positions of the Local OVP Control jumper J65 and the Remote OVP Control jumper J103, both on the Ethernet/RS-232 Interface PCB. The default jumper settings allow control of OVP to depend on the operating state of the power supply. By physically changing the jumper settings, you can isolate the location of OVP control to software control only or front panel control only. [Table 2-12, “OVP Control Mode Selection” on page 2-26](#) shows a table of jumper settings and OVP programming selection. Refer to [Figure 2-3 on page 2-6](#) for the location of the jumpers on the Ethernet/RS-232 Interface PCB. You will need to remove the cover to change any jumpers. See [“Changing Internal Jumpers” on page 2-8](#).

**Table 2-12** OVP Control Mode Selection

PCB Jumper J65 Position	PCB Jumper J103 Position	OVP Programming Selection
Closed (default)	Closed (default)	Software or Front Panel OVP control (dependent on the power supply operating state)
Closed	Open	Software OVP control only
Open	Closed	Front Panel OVP control only
Open	Open	Front Panel OVP control only



## TTL Shutdown Polarity

You can use the Shutdown function to disable or enable the supply's output. Disabling the supply using TTL shutdown allows you to make adjustments to the load or to the power supply without shutting down the power supply. With the Ethernet/RS-232 Interface installed, TTL shutdown is activated by a TTL signal to Pin 1 of the user lines connector on the interface subplate. The shutdown user line uses a 0-5Vdc TTL input with a high signal range of 2.2-5.0Vdc. The current range of the shutdown line is 1-10mA. See [Figure 2-6, “User Lines Signal Connector Circuit Block Diagram”](#) on page 2–29 for a schematic of the user lines connector containing the shutdown user line.

You can select the logic level of the TTL input by changing the J93 connector on the Ethernet/RS-232 Interface PCB. [Table 2-13](#) shows the TTL signal levels for the J93 jumper settings. See [Figure 2-3](#) for the location of the J93 jumper on the printed circuit board. You will need to remove the cover to change any jumpers. See [“Changing Internal Jumpers”](#) on page 2–8.

**Table 2-13** Jumper Settings for TTL Shutdown Circuit Logic

PCB Jumper	J93 Position	TTL Signal Level	Supply Output Condition
Pin 2 to Pin 3 (default)	HIGH	OFF	
	LOW	ON	
Pin 1 to Pin 2	HIGH	ON	
	LOW	OFF	

## User Signals

### User Lines Connector

Auxiliary User Lines connector, located on the Ethernet/RS-232 Interface rear panel, provides several signals to increase your operating control of the supply. These signals are dependent on the operator's design and uses. The operation of the user lines connector signal requires that you provide external Vcc and ground. Use a standard 8-position telephone jack and data cable to connect to the user lines connector. To locate the connector, refer to the Ethernet/RS-232 Interface subplate drawing in [Figure 2-2 on page 2-5](#). See [Table 2-14](#) for pin descriptions. The user lines connector outputs can sink a current of 5mA each. [Figure 2-6 on page 2-29](#) shows the portion of the option board schematic which contains the user line connector. Use the schematic as a reference when making input or output connections.

**Table 2-14** User Signals Connector

Pin	Function
1	External TTL shutdown input signal (See “TTL Shutdown Polarity” on page 2-27)
2	Polarity signal, open collector (asserted by VSET -x)
3	Isolation signal, open collector (asserted by OUT OFF)
4	Fault signal, open collector (asserted when bit set in fault register)
5	External Vcc, 15V maximum (supplied by connecting and operating an external source)
6	External ground and shutdown return (supplied by connecting and operating an external source)
7	Open collector user signal (asserted by AUXA ON)
8	Open collector user signal (asserted by AUXB ON)

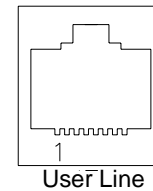

**Note:** On some models, the connector is rotated 180°.

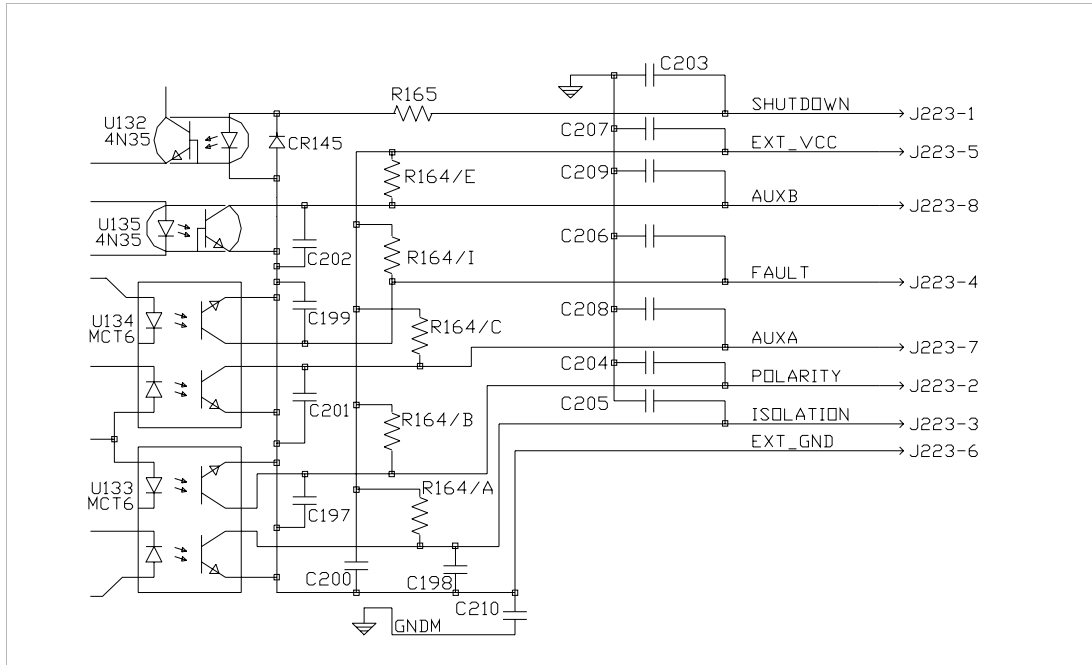

Figure 2-6 User Lines Signal Connector Circuit Block Diagram

## User Lines Cable Connection

Use a standard 8-position telephone jack and data cable to connect to the user line connector. Add a ferrite block to reduce radiated emission. The one inch square ferrite block with built-in housing clip is packaged and shipped with the power supply interface card.

To install the ferrite block:

1. Position the block no more than 5 cm (2 in.) from the power supply end of the user line connector cable.
2. Open the ferrite block housing.
3. Loop the cable through the ferrite block. See [Figure 2-7, “User Lines Cable with Ferrite Block”](#) on page 2–30.
4. Close the housing clip.

The ferrite block ensures that the power supply system meets radiated emission requirement 89/336/EEC for CE mark approval. See the power supply's operating manual for noise specifications.

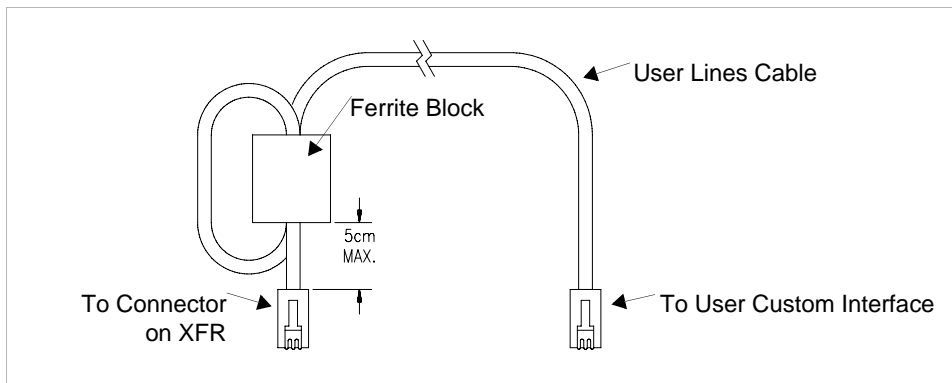

**Figure 2-7** User Lines Cable with Ferrite Block

# 3

## Operation

### Introduction

This section covers Ethernet/RS-232 Interface programming, including an extensive set of device-dependent commands, error codes, and status and fault register information.

## RS-232 Operation

When the Ethernet/RS-232 Interface card is configured for RS-232 you can send and receive data between your power supply and computer, relying on bit serial communication. You can use the computer controller to issue commands to the power supply for programming, queries, calibration, or status. The power supply responds to the complete command set of device dependent software commands shown in “[Command Reference](#)” on page 3–9.

## Ethernet Operation

When the card is configured for Ethernet, you can send and receive data between your power supply and computer via your network. The same command set is used for RS-232 and Ethernet. The only difference is medium and protocol used.

## Command Syntax

### Manual Conventions

The manual uses these conventions when displaying command information. These characters are not part of the command but are used to denote parameters used with the command.

- |                      |  |
|----------------------|--|
| < > (angle brackets) | Angle brackets enclose a parameter. Do not include the angle brackets in the command line you send to the computer.  |
| / (slash)            | Separates two alternative parameters. When a slash separates two parameters, you can use either parameter to achieve the same result.<br>Example: <1/ON><br>Entering 1 or ON will achieve the same result. |

---

## Command Format and Parameters

The device-dependent language for the Ethernet/RS-232 Interface consists of commands and parameters. A command is a one word code which either gives instructions to the interface or asks for information from the interface. A command may be followed by one or more parameters, a short code that changes the state of the power supply or the state of the bit register. [Table 3-1, “Command Parameters” on page 3-4](#) lists the parameters that affect the command set.

### Format:

COMMAND or  
COMMAND <parameter> or  
COMMAND <parameter>,<parameter>

- You can enter commands in upper or lower case lettering.  
Example: MASK FOLD = mask fold
- Do not further abbreviate command names or parameters.  
Example: MASK FOLD ≠ MK FOLD  
MASK FOLD ≠ MASK FD
- Use a space between the command and the first parameter. Any number of consecutive spaces is treated as one space. Numeric data may contain leading spaces. Embedded spaces between digits or between a digit and a decimal point are not accepted.  
Example: MASK FOLD = MASK FOLD  
VOUT 3.4 = VOUT 3.4  
VOUT 3.4 ≠ VOUT 3. 4
- Use commas between parameters in those commands with more than one parameter, and between mnemonic parameters as in the MASK and UNMASK commands. Only one comma is allowed and it may be preceded or followed by any number of spaces.  
Example: MASK CV, OV, FOLD

**Table 3-1** Command Parameters

Parameter	Description	Form
<current>, <Ihi>, <Ilo>	The current in amps or milliamps. If no unit is given, the default unit is amps.	<float> <float>A <float>mA
<time>	The time in seconds or milliseconds. If no unit is given, the default unit is seconds.	<float> <float>s <float>ms
<voltage>, <Vlo>, <Vhi>	The voltage in volts or millivolts. If no unit is given, the default unit is volts.	<float> <float>V <float>mV
<mnemonics>	A combination of CV, CC, CV, OV, OT, SD, FOLD, ERR, PON, REM, ACF, OPF, and SNSP. See MASK and UNMASK commands in the command reference for use of the ALL and NONE parameters.	See registers on <a href="#">page 3-17</a> .
<state>	The state of a binary condition.	<1/ON, 0/OFF>

### Floating Point Number <float>

Variables sent with command parameters are floating point numbers. [Table 3-2](#) defines the structure of floating point numbers for use with the software commands.

**Table 3-2** Floating Point Numbers

Floating Number Definition	Example
The floating point number has four significant figures.	1.234
It can be of either sign, positive or negative.	-1.234 +1.234
A floating point number can have one decimal point.	0.123 1.2 123.4
Scientific Notation	123.0E-1
Use E or e after the number for a base ten exponent.	1.2E-1
An integer of either sign must follow an exponent.	10.00E+1



## Command Strings

If you send more than one command line, separate the commands with a semicolon. The semicolon may be preceded or followed by spaces.

**Example:**

```
ISET 2.0A; VSET 5V  
ISET 2.0A; VSET 5V
```

## Command Terminators

Terminators indicate the end of a command string and tell the power supply to execute the command. The termination character is CR (Carriage Return).

**Format:**

```
COMMAND <parameter>; COMMAND <parameter>,  
<parameter><CR>
```

## Order

You may send commands in any order, keeping in mind that only those commands received after a HOLD and before a TRG (trigger) will be released by the TRG command. In addition, only these commands received after a supply disable (OVP or foldback protection) and before a RST (reset) or OUT ON command will be released by the RST command or the OUT command. Commands are executed in the order they are received.

## Command Summary

Use these commands to control the operation of the supply. They are listed here in order of function such as PROGRAMMING, QUERY, CALIBRATION, and STATUS commands. See “[Command Reference](#)” on page 3–9 for more detailed information about each command and its use.

**Table 3-3** Programming Commands

Command	Description
AUXA	Selects the state of the AUXA output signal on the Pin 7 of the user lines connector.
AUXB	Selects the state of the AUXB output signal on the Pin 8 of the user lines connector.
CLR	Initializes the power supply to its Power ON (PON) state.
DLY	Sets a programmable time delay which is executed by the supply before reporting fault conditions after a new output voltage or current is specified.
GTL	Sends the supply to local mode.
FOLD	Sets foldback mode for the supply.
HOLD	Enables or disables voltage/current setting hold mode for the supply.
IMAX	Sets an upper soft limit on the programmed output current for the supply.
ISET	Sets the output current of the supply in amps (default) or in milliamperes.
LLO	Local Lockout. Disables the front panel LOCAL button.
OUT	Enables or disables voltage/current output for the supply.
OVSET	Sets the over voltage protection trip point for the supply in volts (default) or in millivolts.
REN	Sets remote mode or local mode.
RST	Resets the supply to the present voltage and current settings if the output is disabled by OVP or foldback protection.
TRG	Implements programmed voltage and current settings which had been in hold mode.
VMAX	Sets an upper soft limit on the supply’s programmed output voltage.
VSET	Sets the output voltage of the power supply in volts (default) or in millivolts.

**Table 3-4 Query Commands**

Command	Description
AUXA?	Asks for the state of the set value for the AUXA command
AUXB?	Asks for the state of the set value for the AUXB command
CMODE?	Asks for the power supply's calibration mode status.
DLY?	Asks for the programmable time delay setting before the supply reports fault conditions.
ERR?	Asks for the most recent remote programming error which occurred in the supply since the last time the error query command (ERR?) was used.
FOLD?	Asks for the supply's present foldback setting.
HOLD?	Asks for the present hold mode setting.
ID?	Asks for the power supply's model name and master EPROM version.
IMAX?	Asks for the supply's soft current limit setting.
IOUT?	Measures the supply's actual current output.
ISET?	Asks for the supply's present output current limit setting.
OUT?	Asks for the present enabled/disabled status of the supply's output.
OVSET?	Asks for the supply's present over voltage protection limit.
REN?	Asks for the state of remote enable.
ROM?	Asks for the version number of the master and slave EPROMs on the interface PCB.
VMAX?	Asks for the supply's soft voltage limit setting.
VOUT?	Measures the supply's actual voltage output.
VSET?	Asks for the supply's present output voltage setting.

**Table 3-5 Calibration Commands**

Command	Description
CMODE	Places the supply into calibration mode.
IDATA	Calculates the slope and intercept for current programming.
IHI	Sets the current output to the high calibration point.
ILO	Sets the current output to the low calibration point.
IRDAT	Calculates the slope and intercept for current readback.
IRHI	Sets the current output to the high readback point.
IRLO	Sets the current output to the low readback point.
OVCAL	Calibrates the over voltage protection (OVP).
VDATA	Calculates the slope and intercept for voltage programming.
VHI	Sets the voltage output to the high calibration point.
VLO	Sets the voltage output to the low calibration point.
VRDAT	Calculates the slope and intercept for voltage readback.
VRHI	Sets the voltage output to the high readback point.
VRLO	Sets the voltage output to the low readback point.

**Table 3-6 Status Commands**

Command	Description
ASTS?	Asks for the supply's accumulated status register.
FAULT?	Asks for the supply's fault register for the status preset operating conditions.
MASK	Prevents the supply's previously unmasked operating conditions from setting bits in the fault register.
STS?	Asks for the supply's present status register.
UNMASK	Enables you to select those supply's operating conditions that you are most interested in monitoring for fault occurrence.
UNMASK?	Asks for the supply's fault conditions which are currently enabled (unmasked).

## Command Reference

**Table 3-7** Command Reference

Command	Description
ASTS?	Asks for the supply's accumulated status register. The accumulated status register stores any bit that was entered in the status register since the accumulated status query command (ASTS?) was last used, regardless of whether the condition still exists. The accumulated status register has the same bits, weights, and conditions as the status register. A bit in the accumulated status register will be set at 1 if the corresponding bit in the status register has been 1 (TRUE) at any time since the register was last read. See <a href="#">“Accumulated Status, Status, and Fault Registers”</a> on page 3–17. The ASTS? query clears the status register. Response: ASTS <status mask> where status mask is the decimal equivalent of the total bit weights for the operating conditions as listed in the status register.
AUXA <1/ON>, <0/OFF>	Controls the AUXA output signal level at rear panel connector Pin 7. Active low. Initial value: AUXA 0
AUXA?	Asks for the present set value of the AUXA output signal. Response: AUXA 0 (OFF) or AUXA 1 (ON)
AUXB <1/ON>, <0/OFF>	Controls the AUXB output signal level at rear panel connector Pin 8. Active low. Initial value: AUXB 0
AUXB?	Asks for the present set value of the AUXB output signal. Response: AUXB 0 (OFF) or AUXB 1 (ON)
CLR	Initializes the power supply to its power ON condition. If issued while in local mode, CLR will force power supply settings to register default values as in but these default settings will not come into effect until the power supply is switched to remote mode operation. The CLR commands will clear faults from the fault register. CLR will not reset CMODE.
CMODE <1/ON>, <0/OFF>	CMODE ON places the power supply into calibration mode for processing calibration commands. Initial value: CMODE OFF or CMODE 0
CMODE?	Asks for the power supply's calibration mode status. Response: CMODE 0 (disabled) CMODE 1 (enabled)

**Table 3-7** Command Reference

Command	Description
DLY <seconds>	<p>Sets a programmable time delay employed by the supply before reporting fault conditions. The power supply uses the time delay after receiving a new output voltage or current setting via VSET or ISET, or after receiving RST, TRG, or OUT ON commands. During the time delay, the power supply disables CV, CC, and FOLD conditions from generating faults, preventing possible nuisance foldback if the supply momentarily switches modes while changing an output setting.</p> <p>Range: 0 to 32 seconds, with 32ms resolution Initial value: 0.5 second</p>
DLY?	<p>Asks for the setting of the programmable time delay before the supply reports fault conditions.</p> <p>Response: DLY &lt;seconds&gt;</p>
ERR?	<p>Asks for the most recent remote programming error. When the power supply detects a programming error, it lights the ERR LED and sets the ERR bit in the accumulated status and fault registers. If the error bit has been masked using the MASK command, then the ERR bit in the registers will not set. Once an error is detected, the remaining portion of the command line is discarded. An error query clears the ERR bit in the accumulated status register. See <a href="#">“Error Codes” on page 3–19</a>.</p> <p>Response: ERR &lt;error number&gt; Example: ERR 0 (if no error)</p>
FAULT?	<p>Asks for the state of the fault register. A bit is set in the fault register when a fault arises for that condition. Lists the conditions which activate a fault bit. You can use the MASK command to disable bits from being set in the fault register.</p> <p>When a bit is set in the fault register it also asserts a signal on the Pin 4 user signal line. You can tie the Pin 4 fault line signal to the power supply's own External Shutdown user line, Pin 1, so that the shutdown signal goes low (active) in the case of a user-defined fault.</p> <p>The FAULT? query clears bits in the supply's fault register and fault line.</p> <p>Response: FAULT &lt;fault mask&gt; where fault mask is the decimal equivalent of the total bit weights for the operating conditions as listed in the fault register. See <a href="#">“Accumulated Status, Status, and Fault Registers” on page 3–17</a>.</p>
FOLD <2/CC>, <1/CV>, <0/OFF>	<p>Sets foldback mode for the supply. Foldback protection disables the power supply output when the output enters the fold condition. Reset with the RST command.</p> <p>Example: Specify FOLD 1 or FOLD CV (Constant Voltage) when you want the supply to operate in Constant Current mode and have foldback protection disable the output if the supply switches to Constant Voltage mode.</p> <p>Initial value: FOLD 0/OFF</p>

**Table 3-7** Command Reference

Command	Description
FOLD?	Asks for the supply's present foldback setting. Response: FOLD <mode> where mode is: 0 (OFF) or 1 (CV or Constant Voltage mode) or 2 (CC or Constant Current mode)
GTL	Go to local. Returns the power supply to local control. See LLO (Local Lockout). See also " <a href="#">Remote/Local Operation</a> " on page 2–22.
HOLD <1/ON>, <0/OFF>	Enables or disables voltage/current setting hold mode for the supply. When HOLD ON is specified, hold mode is enabled so that all voltage and current settings which would normally be implemented by the supply are held until a TRG (trigger) command is received. This feature allows you to synchronize the operation of several supplies. Initial value: HOLD OFF or HOLD 0
HOLD?	Asks for the present hold mode setting. Response: HOLD 0 (OFF or disabled) or HOLD 1 (ON or enabled)
ID?	Asks for the power supply model and the master EPROM version. Response: ID <model name><version>
IDATA <Ilo>,<Ihi>	Calculates and records the slope and offset for programmed current using ILO and IHI data. Set CMODE ON before using this command. See also the calibration procedures in <a href="#">Chapter 4</a> . <Ilo> and <Ihi> are in <current> format.
IHI	In response to this command, the power supply sends a programmed current value to the output terminal. This value is at the high end of the power supply's current range and is read by an external device connected as part of the calibration procedure. Refer to this value as IHI and record it to use as input with the IDATA command. Set CMODE ON before using this command. See also the calibration procedures in <a href="#">Chapter 4</a> .
ILO	In response to this command, the power supply sends a programmed current value to the output terminal. This value is at the low end of the power supply's current range and is read by an external device connected as part of the calibration procedure. Refer to this value as ILO and record it to use as input with the IDATA command. Set CMODE ON before using this command. See also the calibration procedures in <a href="#">Chapter 4</a> .

**Table 3-7** Command Reference

Command	Description
IMAX <current>	Sets an upper soft limit on the supply's programmed output current. If the soft limit is exceeded, or if the soft limit value is lower than the present output current setting, the supply will ignore the command, turn on the ERR LED, and set the ERR bit in the bit registers. Range: 0 to model maximum output current (IMAX) Initial value: model IMAX
IMAX?	Asks for the supply's soft current limit setting. Response: IMAX <current>
IOUT?	Measures the supply's actual current output using the built-in current readback circuitry. Response: IOUT <current>
IRDAT <llo>,<lhi>	Calculates and records the slope and offset for readback voltage using IRLO and IRHI data. Set CMODE ON before using this command. See also the calibration procedures in <a href="#">Chapter 4</a> . <llo> and <lhi> are in <current> format.
IRHI	The power supply outputs a current value to an external device connected as part of the calibration procedure and records a current readback value internally. These values are at the high end of the programmed current range. Refer to the output value as IRHI and record it to use as input with the IRDAT command. Set CMODE ON before using this command. See also the calibration procedures in <a href="#">Chapter 4</a> .
IRLO	The power supply outputs a current value to an external device connected as part of the calibration procedure and records a current readback value internally. These values are at the low end of the programmed current range. Refer to the output value as IRLO and record it to use as input with the IRDAT command. Set CMODE ON before using this command. See also the calibration procedures in <a href="#">Chapter 4</a> .
ISET <current>	Sets the power supply's output current in amps (default) or in milliamps. This programmed current is the actual output in CC mode or the current limit in CV mode. Range: 0 to model maximum output current (IMAX) Initial value: 0 amps
ISET?	Asks for the supply's present output current setting. Does not apply to current settings which are being held. See HOLD command. Response: ISET <current>



Table 3-7 Command Reference

Command	Description
LLO	Disables the front panel LOCAL switch. When LLO is in effect you can only return to local mode using the GTL command. You can remove the local lockout with the REN command. See also “ <a href="#">Remote/Local Operation</a> ” on page 2–22.
MASK <mnemonics>	Disables the supply's previously unmasked operating conditions from setting bits in the fault and status registers. See “ <a href="#">Accumulated Status, Status, and Fault Registers</a> ” on page 3–17. Mnemonics are separated from each other by commas and may be sent in any order. Mnemonics: CV, CC, OV, OT, SD, FOLD, ERR, PON, REM, ACF, OPF, SNSP Note: UNMASK NONE = MASK ALL (Initial value) MASK NONE = UNMASK ALL
OUT <1/ON>, <0/OFF>	Enables or disables the supply's voltage/current output. The supply will continue to accept new commands while the output is disabled but these will not be implemented until OUT ON or OUT 1 is received. OUT ON is the default setting. When you start the supply in remote mode, the output is enabled. OUT OFF (or OUT 0) also sets the isolation signal on the rear panel user lines connector, line 3. You can use the to trip external relays to isolate the power supply from the load. Initial value: OUT ON (or OUT 1) for output enabled
OUT?	Asks for the present enabled/disabled status of the supply's output voltage/current. Response: OUT 1 output enabled or OUT 0 output disabled
OVCAL	Causes the master controller to perform automatic calibration of the supply's over voltage protection circuitry. Set CMODE ON before using this command. Ensure jumper J65 on the <a href="#">Ethernet/RS-232 Interface PCB</a> is connected for remote operation.
OVSET <voltage>	Sets the supply's over voltage protection trip point in volts (default) or in millivolts. If the trip point is exceeded, or if the trip point value is lower than the present output voltage setting, the supply will ignore the command, turn on the ERR LED, and set the ERR bit in the accumulated status register. Reset with the RST command. Range: 0 to 110% of model maximum output voltage (VMAX) Initial value: 110% of model VMAX
OVSET?	Asks for the supply's present over voltage protection limit. Response: OVSET <voltage>

**Table 3-7** Command Reference

Command	Description
REN <1/ON>, <0/OFF>	Remote Enable. When set to REN 0, the power supply is in local mode. If a command is sent from the computer, the power supply does not respond but remains in local mode. When set to REN 1, the power supply will enter remote mode if a command is sent from the computer. See also “Remote/Local Operation” on page 2–22.
REN?	Asks for the state of the remote enable. See REN command. Response: REN <state>
ROM?	Asks for the version number of the master and slave EPROMs located on the interface PCB. Response: ROM M:<version> S:<version>
RST	Resets the supply to present voltage and current settings if the output is disabled by over voltage or foldback protection. Output values may be changed via VSET, ISET, and OVSET while the unit is disabled, but those values will not take effect until RST is applied.
STS?	Asks for the supply’s present status register. Status conditions are stored in the status register. Each bit represents a separate condition. When the condition is true, the corresponding bit is 1 (true). Bits remain set in the status register as long as the condition is true. See “Accumulated Status, Status, and Fault Registers” on page 3–17. Response: STS <status mask> where status mask is the decimal equivalent of the total bit weights for the operating conditions as listed in the status register.
TRG	Implements programmed voltage and current settings which had been in hold mode. The supply operates with previous values until the TRG (trigger) command is sent.
UNMASK <mnemonics>	Enables you to select the supply operating conditions that you are most interested in monitoring for fault occurrence. Mnemonics describing the conditions are separated from each other by commas, and may be sent in any order. Specifying one or more mnemonics which describe the conditions (or the decimal equivalent of their total bit weight) enables the selected conditions to set bits in the supply’s fault and status registers during operation. A bit is set in the fault register when the corresponding bit in the status register changes from 0 to 1 and the corresponding bit in the mask register is 1. See “Accumulated Status, Status, and Fault Registers” on page 3–17. Mnemonics:CV, CC, OV, OT, SD, FOLD, ERR, PON, REM, ACF, OPF, SNSP, ALL, NONE Initial value:UNMASK NONE

Table 3-7 Command Reference

Command	Description
UNMASK?	Asks for the supply's fault conditions which are currently enabled (unmasked). Response: UNMASK <fault mask> where fault mask is the decimal equivalent of the total bit weights for the operating conditions as listed in the status and fault registers See “Accumulated Status, Status, and Fault Registers” on page 3–17.
VDATA <Vlo>,<Vhi>	Calculates and records the slope and offset for programmed voltage using VLO and VHI data. Set CMODE ON before using this command. See also the calibration procedures in Chapter 4. <Vlo> and <Vhi> are in <voltage> format.
VHI	In response to this command, the power supply sends a programmed voltage value to the output terminal. This value is at the high end of the power supply's voltage range and is read by an external device connected as part of the calibration procedure. Refer to this value as VHI and record it to use as input with the VDATA command. Set CMODE ON before using this command. See also the calibration procedures in Chapter 4.
VLO	In response to this command, the power supply sends a programmed voltage value to the output terminal. This value is at the low end of the power supply's voltage range and is read by an external voltmeter connected as part of the calibration procedure. Refer to this value as VLO and record it to use as input with the VDATA command. Set CMODE ON before using this command. See also the calibration procedures in Chapter 4.
VMAX <voltage>	Sets an upper soft limit on the supply's programmed output voltage. If the soft limit is exceeded, or if the soft limit value is lower than the present output voltage setting, the supply will ignore the command, turn on the ERR LED, and set the ERR bit in the accumulated status register. Range: 0 to model maximum output voltage (VMAX) Initial value: model VMAX
VMAX?	Asks for the supply's soft voltage limit setting. Response: VMAX <voltage>
VOUT?	Measures the supply's actual voltage output using the built-in voltage readback circuitry. Response: VOUT <voltage>
VRDAT <Vlo>,<Vhi>	Calculates and records the slope and offset for readback voltage using VRLO and VRHI data. Set CMODE ON before using this command. See also the calibration procedures in Chapter 4 . <Vlo> and <Vhi> are in <voltage> format.

**Table 3-7** Command Reference

Command	Description
VRHI	The power supply outputs a voltage value to an external voltmeter connected as part of the calibration procedure and records a voltage readback value internally. These values are at the high end of the programmed voltage range. Refer to the output value as VRHI and record it to use as input with the VRDAT command. Set CMODE ON before using this command. See also the calibration procedures in <a href="#">Chapter 4</a> .
VRLO	The power supply outputs a voltage value to an external voltmeter connected as part of the calibration procedure and records a voltage readback value internally. These values are at the low end of the programmed voltage range. Refer to the output value as VRLO and record it to use as input with the VRDAT command. Set CMODE ON before using this command. See also the calibration procedures in <a href="#">Chapter 4</a> .
VSET <voltage> or VSET <-voltage>	Sets the power supply's output voltage in volts (default) or in millivolts. This programmed voltage is the actual output in CV (constant voltage) mode or the voltage limit in CC (constant current) mode. If you enter a negative voltage value, the power supply will assert a signal on Pin 4 of the user signal line. You can use the user signal to trip external relays to switch the output polarity. Range: 0 to model maximum output voltage (VMAX) Initial value: 0 volts
VSET?	Asks for the power supply's present output voltage setting. Does not apply to voltage settings which are being held. See HOLD command. Response: VSET <voltage>

## Accumulated Status, Status, and Fault Registers

The Ethernet/RS-232 Interface card uses three separate registers which are always active. They are the accumulated status, status, and fault registers. You can use the status commands shown in [Table 3-6, “Status Commands” on page 3-8](#) to activate the registers. The bit register has twelve conditions, each assigned a bit weight. When querying a register, the controller returns a response which is the sum of the weights of all relevant conditions.

**Example:**

ASTS?	Query the Accumulated Status register.
ASTS 771	Controller response.
$771 = 512 + 256 + 2 + 1 = \text{PON} + \text{REM} + \text{CC} + \text{CV}$	

The accumulated status register shows that PON, REM, CC and CV have all been active since the last accumulated status register query.

[Table 3-8](#) shows the mnemonics and bit weights which correspond to each register condition. You can select conditions you want to monitor in the fault and status register by using the MASK and UNMASK commands.

**Table 3-8** Accumulated Status, Status and Fault Registers

Condition	Mnemonic	Bit Position	Bit Weight
Constant voltage operation	CV	0	1
Constant current operation	CC	1	2
Not used	–	2	4
Overvoltage protection tripped	OV	3	8
Over temperature protection tripped	OT	4	16
Supply external shutdown active Pin 1 of the user lines connector	SD	5	32
Foldback mode operation	FOLD	6	64
Remote programming error	ERR	7	128
Power ON (accumulated status, status registers only)	PON	8	256
Remote mode (accumulated status, status registers only)	REM	9	512
AC fail condition	ACF	10	1024
Output fail condition	OPF	11	2048
Sense protection tripped	SNSP	12	4096

Notes:

1. All mnemonics can be masked or unmasked.
2. The error (ERR) bit is reset in the accumulated status, status, and serial poll registers with an error query (ERR?).
3. The accumulated status register is cleared with an accumulated status query (ASTS?).
4. A fault is cleared with a fault query (FAULT?).

## Error Codes

If the ERR flag in the accumulated status or fault registers has been activated, an ERR? query will return an error number which corresponds to an event described in the following table. The ERR? query will also clear the ERR bit in the register.

**Table 3-9** Error Codes

Error #	Error Identification	Explanation
0	No Errors	
4	Unrecognized Character	Received a character such as @,*,\$.
	Improper Number	Received a numeric character but the characters were not a proper number. Example: VSET,±10.3
	Unrecognized String	Received an invalid command.
	Syntax Error	Received an incorrectly placed word, number, separator, or terminator. Example: OFF SRQ, VOUT 6, MASK, ERR
5	Number Out of Range	Specified a value for the command which was outside of the allowed range.
6	Attempt to Exceed Soft Limits	Attempted to program a voltage or current greater than the soft limit. Example: VMAX 500; VSET 550 LF
7	Improper Soft Limit	Attempted to program a soft limit less than the output value.
8	Data Requested without a Query Being Sent	The controller requested data from the power supply without first sending a query command.
9	OVP Set Below Output	Sent an OVSET command with a trip value lower than the output voltage.
10	Slave Processor Not Responding	The interface PCB slave processor did not respond.
12	Illegal Calibration	Attempted calibration when the supply was not in calibration mode. See CMODE command.

## Troubleshooting

---



### WARNING

Exercise caution when using and servicing power supplies. High energy levels can be stored at the output voltage terminals on all power supplies in normal operation. In addition, potentially lethal voltages exist in the power circuit and the output connector of power supplies which are rated at 40V and over. Filter capacitors store potentially dangerous energy for some time after power is removed.

---

### Diagnostic LEDs

This section describes the diagnostic LEDs found on the Ethernet/RS-232 Interface.

#### Computer Operating Properly (COP) LEDs

The Ethernet/RS-232 Interface provides three diagnostic LEDs, located at CR167, CR166, and CR89 on its PCB. Refer to [Figure 2-3, “Ethernet/RS-232 Interface PCB”](#) on page 2–6, for their locations. At present, these LEDs turn on to signal COP events for the interface's microprocessors. Issue a RST (reset) command to turn off the diagnostic LEDs.

The green COP LED at circuit designation CR167 indicates that the Ethernet/RS-232 Interface microprocessor successfully recovered from a timeout error due to a communications bus error. The event is transparent to the RS-232 communications line which continues to function normally.

The red COP LED at CR166 indicates that a transparent restart caused by noise in the master processor circuitry has occurred.

The red COP LED at CR89 indicates that a transparent restart caused by noise in the slave processor circuitry has occurred.



## Ethernet Mode Troubleshooting Tips

**Table 3-10 Ethernet Mode Tips**

Symptom	Possible Causes	Corrective Actions
Cannot establish communication or cannot find XFR on network using the setup program from the CD	Instrument is not properly connected to the network	<p>Check the four Ethernet LEDs at the back of the XFR. If the green Network LED is NOT permanently illuminated, check the connection.</p> <p>Ensure that the Ethernet cable is securely connected to the RJ45 Ethernet connector and not to the User Line (User Int) connector.</p> <p>Ensure that the network drop is live - check with your IT department for assistance with this.</p> <p>If you are connecting the instrument to a network hub, ensure that you are using a straight-through CAT5 network cable.</p> <p>If you are connecting the instrument directly to your computer, ensure that you are using a cross-over CAT5 network cable. You also need to ensure that the network settings on your computer have been changed so that your computer uses a static IP address.</p> <p>If the problem persists, press the Ethernet Reset button (SW1) on the back panel and wait 45 seconds to see if the Green Network LED illuminates permanently.</p>
	Trying to connect to the wrong IP address	<p>Use the Support software that came with your power supply to find the instrument on your network. If it is properly connected to the network, the <i>Device Discovery</i> program will locate the unit and display its IP address.</p>
	Not waiting long enough after turning the power on, or resetting the Ethernet Bridge	<p>Wait 30-45 seconds at power on to allow the Ethernet Bridge to complete its start-up routine.</p>

**Table 3-10 Ethernet Mode Tips**

Symptom	Possible Causes	Corrective Actions
Able to connect to the device server (Ethernet Bridge), but unable to control or receive a response from the power supply.	<p>The <b>Ethernet/RS-232 Interface</b> card is configured for RS-232 communications</p> <p>The embedded Ethernet Bridge is incorrectly configured.</p>	<p>Reconfigure the interface card for Ethernet communications. See <a href="#">page 2–12</a> for details.</p> <p>Ensure that the baud rate for the Ethernet Bridge is set for 9600 by connecting to its HTTP server and checking its <i>Serial Port</i> settings. This can be done by entering the device's IP address into a web browser and using the correct username and password to access the device server. See <a href="#">“Configuring Ethernet Bridge” on page 2–15</a> for more information.</p> <p>Ensure that the baud rate setting on the interface card is set to 9600 - see the <a href="#">“Baud Rate Selection” on page 2–20</a> for details.</p>
Change from DHCP to Static IP address via Web browser, did not take effect.	Power supply cannot find valid DHCP server.	Use the alternate method of configuring with the ARP Ping command described in <a href="#">“Configuring Ethernet Bridge” pp 2-15 to 2-16</a> .

## RS-232 Mode Troubleshooting Tips

**Table 3-11** RS-232 Mode Tips

Symptom	Possible Causes	Corrective Actions
Cannot establish communication	Using straight through RS-232 cable instead of Null Modem cable	Use a Null Modem cable
	Loose cables	Ensure that the cables are securely connected to the computer and the power supply.
	Baud rate mismatch	Select a baud rate that matches the instruments settings. See “ <a href="#">Baud Rate Selection</a> ” on page 2–20 for details on changing this setting.
	Trying to communicate via the wrong COM port	Most computers have two COM ports, COM1 and COM2, so ensure you have selected the correct COM port.
	The interface card is configured for Ethernet communications	Reconfigure the interface card for RS-232 communications. See “ <a href="#">Configuring for Ethernet or RS-232</a> ” on page 2–12 for details.

## RS-232 and/or Ethernet Mode Troubleshooting Tips

**Table 3-12** RS-232 and/or Ethernet Mode Tips

Symptom	Possible Causes	Corrective Actions
Instrument not responding to new user settings	The unit is in local mode	Put the unit into remote mode by sending the command REN ON.
The output is displaying zero volts and zero amps, but the setpoints are non-zero	The output is off	Send the command OUT ON
	The output has tripped due to an OVP, or foldback protection event	Correct the condition that has caused the fault, and send the command RST



# 4

## Calibration

### Introduction



#### **WARNING**

Exercise caution when using and servicing power supplies. High energy levels can be stored at the output voltage terminals on all power supplies in normal operation. In addition, potentially lethal voltages exist in the power circuit and the output connector of power supplies which are rated at 40V and over. Filter capacitors store potentially dangerous energy for some time after power is removed.

---

You can calibrate the interface in either Ethernet or RS-232 mode by adjusting the signal levels on the interface card so that they correspond to the expected signal levels on the power supply's main assembly. You may need to recalibrate the interface if you replace parts either on the interface board or on the main power supply board, or if the unit falls out of specification due to component aging drifts.

You can calibrate the Ethernet/RS-232 Interface for:

- Voltage program
- Voltage readback
- Current program
- Current readback
- Overvoltage protection

The following equipment will be required to accurately calibrate your unit:

- Digital Voltmeter, 5 1/2 digit, 0.1% accuracy or better, with test leads
- Current sensing shunt resistor, rated for 150% of maximum output current, 0.25% accuracy or better
- Connection wires rated for the unit's maximum output current and voltage
- A network ready, or RS-232 equipped computer to send the calibration commands to the unit

Calibrate the unit according to the following procedures, referring to “Command Reference” for more information about the calibration commands used.

The calibration procedures in this section are designed to be performed at an ambient temperature of  $25^{\circ}\text{C} \pm 5^{\circ}\text{C}$ .

## Voltage Mode Calibration

### Voltage Calibration Setup

1. Disconnect the load from the power supply which is to be calibrated.
2. Connect a voltmeter across the power supply's output terminals.

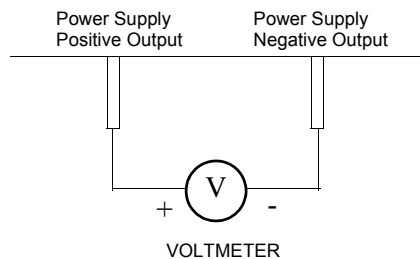

Figure 4-1 Voltage Calibration Setup

### Voltage Program Calibration Procedure

1. Set the power supply for calibration as in [Figure 4-1](#).
2. Activate calibration mode by sending command CMODE ON or CMODE 1 to the power supply.
3. Send command VLO; ILO to the power supply. Measure and record the output shown on the external voltmeter.
4. Send command VHI; IHI to the supply. Measure and record the output voltage as shown on the external voltmeter.
5. Send the command VDATA <vlo>,<vhi> where <vlo> and <vhi> are the values read from the voltmeter when the VLO and VHI commands were sent. When the power supply is calibrated, the low to high voltage program calibration values are stored as constants.
6. Program the supply at various levels using the VSET command to confirm that the calibration was successful and that linearity is observed. See the voltage program accuracy specification in Appendix A.
7. Turn off calibration mode by sending the command CMODE OFF or CMODE 0 to the power supply.

## Voltage Readback Calibration Procedure

1. Set the power supply for calibration as in [Figure 4-1](#).
2. Activate calibration mode by sending command CMODE ON or CMODE 1 to the power supply.
3. Send command VRLO; IRLO to the power supply. Wait for the supply to settle. Measure and record the output shown on the external voltmeter. Send VRLO again.
4. Send VRHI; IRHI to the supply. Wait for the supply to settle. Measure and record the output voltage shown on the external voltmeter. Send VRHI again.
5. Send the command VRDAT <vlo>,<vhi> where <vlo> and <vhi> are the values read from the voltmeter after the VRLO and VRHI commands were sent. The processor calculates the offset value required to calibrate the power supply. When the power supply is calibrated, the low to high voltage readback calibration values (offsets) are stored as constants.
6. Use commands VSET and VOUT? commands to confirm that the calibration was successful and that linearity is observed. Refer to the voltage readback accuracy specification in Appendix A.
7. Turn off calibration mode by sending the command CMODE OFF or CMODE 0 to the power supply.



## Current Mode Calibration

### Current Calibration Setup

1. Disconnect the load from the power supply to be calibrated.
2. Connect a shunt across the supply's output terminals.
3. Connect a voltmeter across the shunt.

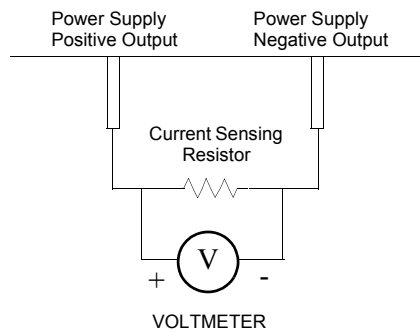

**Figure 4-2** Current Calibration Setup

### Current Program Calibration Procedure

1. Connect the shunt and voltmeter to the power supply as shown in [Figure 4-2](#).
2. Activate calibration mode by sending command CMODE ON or CMODE 1 to the power supply.
3. Send command ILO; VLO to the power supply. Measure and record the output shown on the external voltmeter.
4. Send command IHI; VHI to the supply. Measure and record the output voltage shown on the external voltmeter.
5. Calculate ILO and IHI from the voltages read from the external voltmeter and the shunt resistance.  $I=V/R$ .
6. Send the command IDATA <ilo>,<ihi> to the power supply. <ilo> and <ihi> are the current values obtained from sending the ILO and IHI commands to the power supply. When the power supply is calibrated, the low to high current program calibration values are stored as constants.

7. Program the supply at various levels using the ISET command to confirm that the calibration was successful and that linearity is observed. Refer to the current program accuracy specification in Appendix A.
8. Turn off calibration mode by sending the command CMODE OFF or CMODE 0 to the power supply.

### Current Readback Calibration Procedure

1. Connect the current shunt and voltmeter to the power supply as shown in [Figure 4-2](#).
2. Activate calibration mode by sending command CMODE ON or CMODE 1 to the power supply.
3. Send command IRLO; VRLO to the power supply. Wait for the supply to settle. Measure and record the output voltage shown on the external voltmeter. Send IRLO again.
4. Send command IRHI; VRHI to the supply. Wait for the supply to settle. Measure and record the output voltage shown on the external voltmeter. Send IRHI again.
5. Calculate IRLO and IRHI from the voltages taken from the external voltmeter and the shunt resistance.  $I=V/R$ .
6. Send the command IRDAT <ilo>,<ihi> to the power supply. <ilo> and <ihi> are the current values obtained from sending the IRLO and IRHI commands to the power supply. When the power supply is calibrated, the low to high current readback calibration values are stored as constants.
7. Program the supply at various levels using the ISET command to confirm that the calibration was successful and that linearity is observed. Refer to the current readback accuracy specification in Appendix A.
8. Turn off calibration mode by sending the command CMODE OFF or CMODE 0 to the power supply.

## Over Voltage Protection (OVP) Calibration

We recommend that you perform OVP calibration every six months. Connecting a digital voltmeter as in “[Voltage Calibration Setup](#)” is optional.

1. Disconnect all loads from the power supply.
2. Ensure that jumper J65 on the interface PCB is CLOSED to enable remote OVP calibration (Jumper J65 is closed at the factory). See Figure 2-3, “Ethernet/RS-232 Interface PCB” on page 2–6 for the location on the PCB of jumper J65.
3. Activate calibration mode by sending command CMODE ON or CMODE 1 to the power supply.
4. Send the command OVCAL to the power supply. The ADDR LED will light during OVP calibration. Calibration is complete when the ADDR LED turns off. This may take a few minutes.
5. Use the OVSET, OVSET?, and VSET commands to trip the OVP level, confirming that the calibration was successful. When you trip the OVP level, the red OVP LED will light and the voltage will drop to zero. Send the command RST to clear the OVP condition. Refer to the OVP program accuracy specification in Appendix A.
6. Turn off calibration mode by sending the command CMODE OFF or CMODE 0 to the power supply.



# A

## Specifications

The specifications in this section are warranted at  $25^{\circ}\text{C} \pm 5^{\circ}\text{C}$  unless otherwise specified. All specifications are subject to change without notice.

## Specifications for XFR 1.2kW with Ethernet/RS-232 Interface Installed

**Table A-1** XFR 1.2kW 7.5 V to 40 V

Models	7.5-140	12-100	20-60	35-35	40-30
Program Resolution					
Voltage	1.2mV	3.1mV	5.1mV	5.4mV	6.2mV
Current	18.3mA	7.1mA	4.7mA	5.4mA	3.6mA
OVP	1.2mV	3.1mV	5.1mV	5.4mV	6.2mV
Program Accuracy <sup>a</sup>					
Voltage	10mV ±0.12%	75mV ±0.12%	75mV ±0.12%	75mV ±0.3%	75mV ±0.3%
Current	500mA ±0.1%	250mA ±0.1%	165mA ±0.15%	200mA ±0.1%	140mA ±0.15%
OVP	80mV	200mV	330mV	350mV	400mV
Readback Resolution					
Voltage	1.2mV	3.1mV	5.1mV	5.4mV	6.2mV
Current	18.3mA	7.1mA	4.7mA	5.4mA	3.6mA
Readback Accuracy <sup>a</sup>					
Voltage	30mV ±0.12%	75mV ±0.12%	75mV ±0.2%	75mV ±0.3%	75mV ±0.3%
Current	500mA ±0.1%	250mA ±0.1%	165mA ±0.15%	200mA ±0.1%	140mA ±0.15%

- a. Apply accuracy specifications according to the following voltage program accuracy example:  
 Set a model 20-60 power supply to 10 volts.  
 The expected result will be within the range of 10 volts ± 75mV ± 0.12% of the set voltage of 10 volts.

**Table A-2 XFR 1.2kW 60 V to 600 V**

<b>Models</b>	<b>60-20</b>	<b>100-12</b>	<b>150-8</b>	<b>300-4</b>	<b>600-2</b>
<b>Program Resolution</b>					
Voltage	9.3mV	15.5mV	23.2mV	46.4mV	92.7mV
Current	2.6mA	1.5mA	1.0mA	0.5mA	0.3mA
OVP	9.3mV	15.5mV	23.2mV	46.4mV	92.7mV
<b>Program Accuracy<sup>a</sup></b>					
Voltage	150mV ±0.25%	150mV ±0.35%	225mV ±0.35%	225mV ±0.35%	300mV ±0.35%
Current	120mA ±0.1%	80mA ±0.1%	80mA ±0.1%	80mA ±0.1%	75mA ±0.1%
OVP	600mV	1.0V	1.5V	3.0V	6V
<b>Readback Resolution</b>					
Voltage	9.3mV	15.5mV	23.2mV	46.4mV	92.7mV
Current	2.6mA	1.5mA	1.0mA	0.5mA	0.3mA
<b>Readback Accuracy<sup>a</sup></b>					
Voltage	150mV ±0.25%	150mV ±0.35%	225mV ±0.35%	225mV ±0.35%	300mV ±0.35%
Current	120mA ±0.1%	80mA ±0.1%	80mA ±0.1%	80mA ±0.1%	75mA ±0.1%

- a. Apply accuracy specifications according to the following voltage program accuracy example:  
 Set a model 20-60 power supply to 10 volts.  
 The expected result will be within the range of 10 volts ± 75mV ± 0.12% of the set voltage of 10 volts.

## Specifications for XFR 2.8kW with Ethernet/RS-232 Interface Installed

**Table A-3** XFR 2.8kW 7.5 V to 40 V

Models	7.5-300	12-220	20-130	33-85	40-70
Program Resolution					
Voltage	1.2mV	3.1mV	5.1mV	5.1mV	6.2mV
Current	11.3mA	4.3mA	2.6mA	13.0mA	2.2mA
OVP	1.2mV	3.1mV	5.1mV	5.1mV	6.2mV
Program Accuracy <sup>a</sup>					
Voltage	10mV ±0.12%	75mV ±0.12%	75mV ±0.12%	75mV ±0.3%	75mV ±0.3%
Current	300mA ±0.15%	165mA ±0.15%	120mA ±0.15%	425mA ±0.1%	110mA ±0.15%
OVP	75mV	200mV	330mV	330mV	400mV
Readback Resolution					
Voltage	1.2mV	3.14mV	5.1mV	5.1mV	6.2mV
Current	11.3mA	4.3mA	2.6mA	13.0mA	2.2mA
Readback Accuracy <sup>a</sup>					
Voltage	10mV ±0.12%	75mV ±0.12%	75mV ±0.2%	75mV ±0.3%	75mV ±0.3%
Current	300mA ±0.15%	165mA ±0.15%	120mA ±0.15%	425mA ±0.1%	110mA ±0.15%

- a. Apply accuracy specifications according to the following voltage program accuracy example:  
 Set a model 20-130 power supply to 10 volts.  
 The expected result will be within the range of 10 volts ± 75mV ± 0.12% of the set voltage of 10 volts.



**Table A-4 XFR 2.8kW 60 V to 600 V**

<b>Models</b>	<b>60-46</b>	<b>100-28</b>	<b>150-18</b>	<b>300-9</b>	<b>600-4</b>
<b>Program Resolution</b>					
Voltage	9.3mV	15.5mV	23.2mV	46.4mV	92.7mV
Current	1.4mA	0.9mA	0.6mA	0.3mA	0.2mA
OVP	9.3mV	15.5mV	23.2mV	46.4mV	92.7mV
<b>Program Accuracy<sup>a</sup></b>					
Voltage	150mV ±0.3%	150mV ±0.35%	225mV ±0.35%	225mV ±0.35%	300mV ±0.35%
Current	80mA ±0.1%	80mA ±0.1%	80mA ±0.1%	75mA ±0.1%	75mA ±0.1%
OVP	600mV	1.0V	1.5V	3.0V	6V
<b>Readback Resolution</b>					
Voltage	9.3mV	15.5mV	23.2mV	46.4mV	92.7mV
Current	1.4mA	0.9mA	0.6mA	0.3mA	0.2mA
<b>Readback Accuracy<sup>a</sup></b>					
Voltage	150mV ±0.3%	150mV ±0.35%	225mV ±0.35%	225mV ±0.35%	300mV ±0.35%
Current	80mA ±0.1%	80mA ±0.1%	80mA ±0.1%	75mA ±0.1%	75mA ±0.1%

- a. Apply accuracy specifications according to the following voltage program accuracy example:  
 Set a model 20-130 power supply to 10 volts.  
 The expected result will be within the range of 10 volts ± 75mV ± 0.12% of the set voltage of 10 volts



# B

## Advanced Ethernet Administration

Appendix B details how to change your network password, view port statistics and interpret LED information.

## Changing the Root Password

For security reason you will want to change the root password immediately.

---

**Important:** Record you new password in a secure location. If you lose the password you will not be able to gain access to the configuration menu. The unit would have to be shipped back to the manufacturer to have the Ethernet Bridge reset if you need to make further changes to the Ethernet settings.

---

This procedure assumes that you are the root user and that you know the current root password.

1. Open a web browser and enter the device server's IP address in the URL window.
2. When the device server prompts you to log in, enter the following:
  - root as the user name
  - the root password (default is dbps)
3. Click *Administration Password* from the main menu.
4. Fill in the New Password and Confirm Password fields and then click *Apply*. Record your password here:

---

# Resetting the Configuration to Defaults

## Introduction

This procedure will reset the configuration to defaults by using a web browser. This procedure also allows you to back up the configuration which provides a means for restoring it after you have worked through configuration issues. See “Copying the Configuration to and from a Server” on page 5–4 for more information.

## Resetting the Configuration from a Browser

1. Open a web browser and enter the device server’s IP address in the URL window.
2. When the device server prompts you to log in, enter the following:
  - root as the user name
  - the root password (default is dbps)
3. Click *Restore Factory Ddefault Settings* from the main menu.

## Copying the Configuration to and from a Server

This procedure shows you how to copy the configuration to a server and to download a configuration from a server.

1. Open a web browser and enter the device server's IP address in the URL window.
2. When the device server prompts you to log in, enter the following:
  - User name (default: root)
  - Password (default: dbps)
3. Click *Backup/Restore* from the main menu.
4. Follow the instructions to complete the procedure.

## Viewing Port Statistics and Settings

Use this procedure to view port statistics and configuration settings.

1. Open a web browser and enter the device server's IP address in the URL window.
2. When the device server prompts you to log in, enter the following:
  - User name (default: root)
  - Password (default: dbps)
3. Click *System Information* from the main menu.
4. Use the on-screen links to get the desired information.

## Viewing Network Statistics

Use this procedure to view network statistics.

1. Open a web browser and enter the device server's IP address in the URL window.
2. When the device server prompts you to log in, enter the following:
  - User name (default: root)
  - Password (default: dbps)
3. Click *System Information* from the main menu.
4. Use the on-screen links to get the desired information.

## Interpreting LED Information

Ethernet Bridge LEDs provide information on port activity, diagnostics, and Ethernet activity.

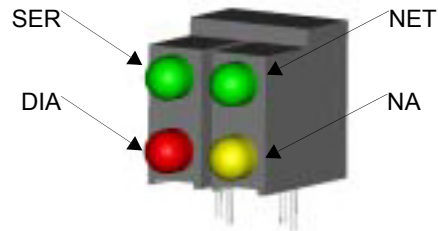

**Figure 5-1** Ethernet Bridge LEDs

**Table 5-1** Ethernet Bridge LEDs Interpretation

LED	Color	Function	Interpretation
SER	Green	Indicates serial port activity	<ul style="list-style-type: none"> <li>Off means that the serial channel is idle.</li> <li>Blinking indicates an active connection.</li> </ul>
NET	Green	Network link status	<ul style="list-style-type: none"> <li>Off means that no link has been detected.</li> <li>On means that a link has been detected.</li> </ul>
DIA	Red	Diagnostics	<ul style="list-style-type: none"> <li>Blinking 1-1-1 means starting the operating system.</li> <li>Blinking 1-5-1 means configuration has been returned to factory defaults.</li> <li>Steady blinking means the device is seeking an IP address from a DHCP server.</li> </ul>
NA	Yellow	Reserved	N/A

