



US 20050056036A1

(19) **United States**

(12) **Patent Application Publication**
O'Baid et al.

(10) **Pub. No.: US 2005/0056036 A1**

(43) **Pub. Date: Mar. 17, 2005**

(54) **INTEGRATED CRYOGENIC RECEIVER FRONT-END**

(52) **U.S. Cl.** 62/259.2; 62/6; 165/104.21; 165/104.33

(75) **Inventors: Amr Hassan O'Baid, Goleta, CA (US); Brent James Swartzentruber, Carpinteria, CA (US)**

(57) **ABSTRACT**

Correspondence Address:
O'MELVENY & MEYERS
114 PACIFICA, SUITE 100
IRVINE, CA 92618 (US)

A cryogenic receiver front-end includes a heat sink having a mounting surface and a plurality of fins, a cryocooler mounted to the mounting surface of the heat sink, a heat rejector surrounding the cryocooler, the heat rejector including a plurality of pliable c-shaped recesses therein, and a plurality of heat pipes. Each heat pipe has first and second ends, the first ends of the plurality of heat pipes are disposed in respective c-shaped recesses of the heat rejector. A working fluid is contained inside the heat pipes. The second ends of the plurality of heat pipes are thermally coupled to the heat sink. A weather resistant enclosure unit is mounted to the heat sink and encloses the components of the cryogenic receiver front-end.

(73) **Assignee: Superconductor Technologies, Inc.**

(21) **Appl. No.: 10/666,634**

(22) **Filed: Sep. 17, 2003**

Publication Classification

(51) **Int. Cl.⁷** F25B 9/00; F28D 15/00; F25D 23/12

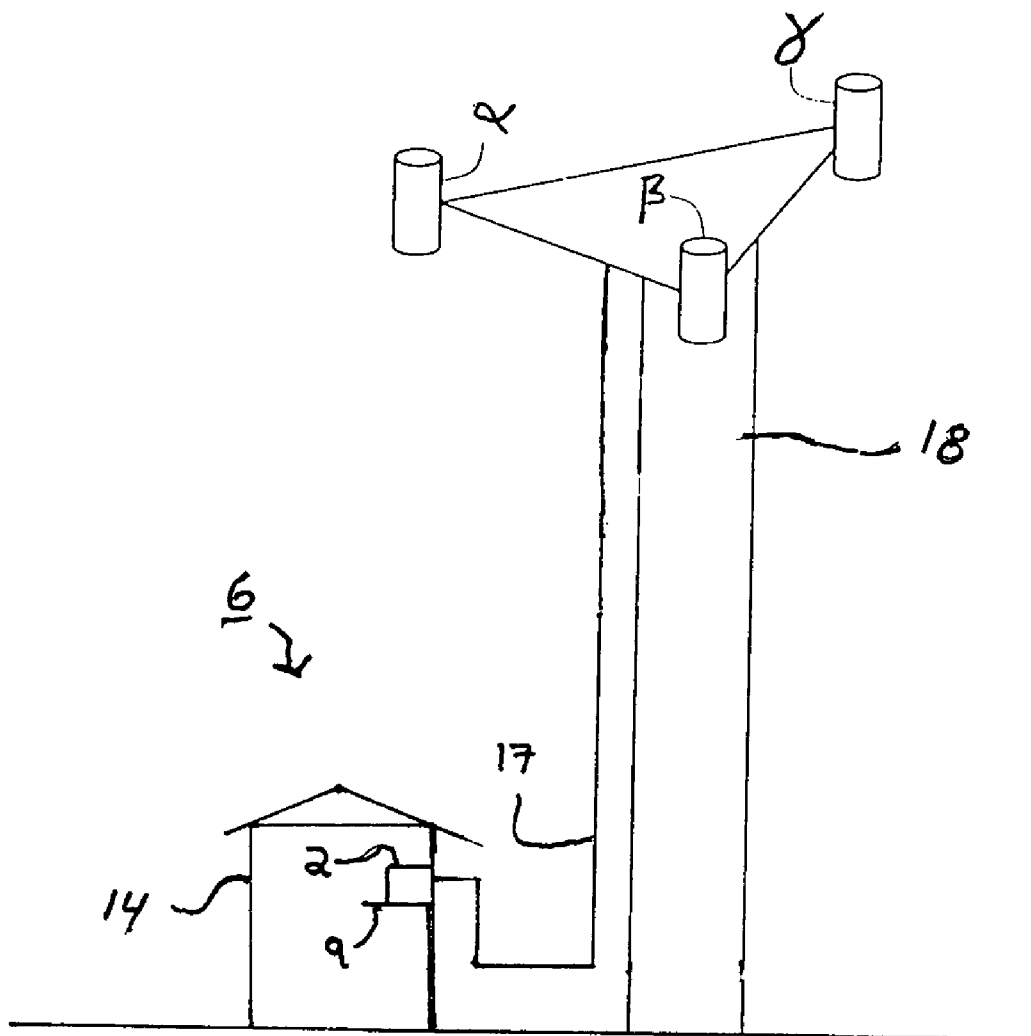

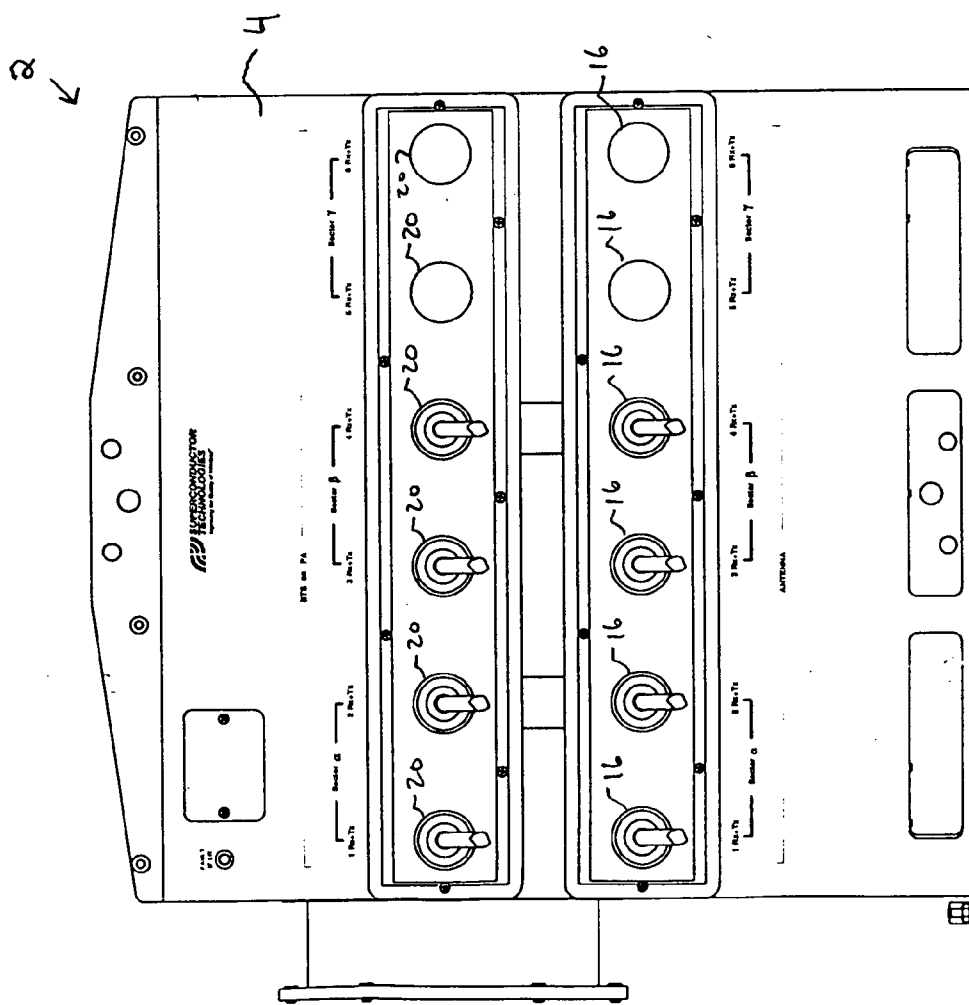

Fig. 1

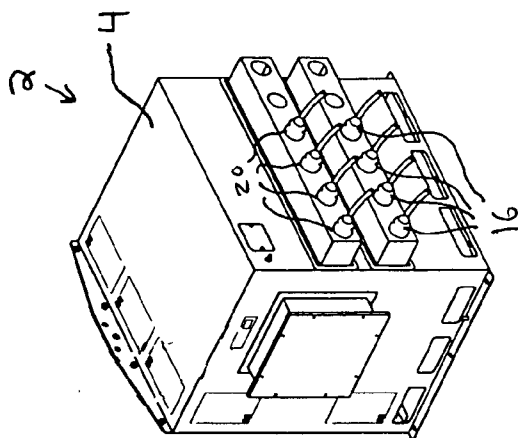

Fig. 2

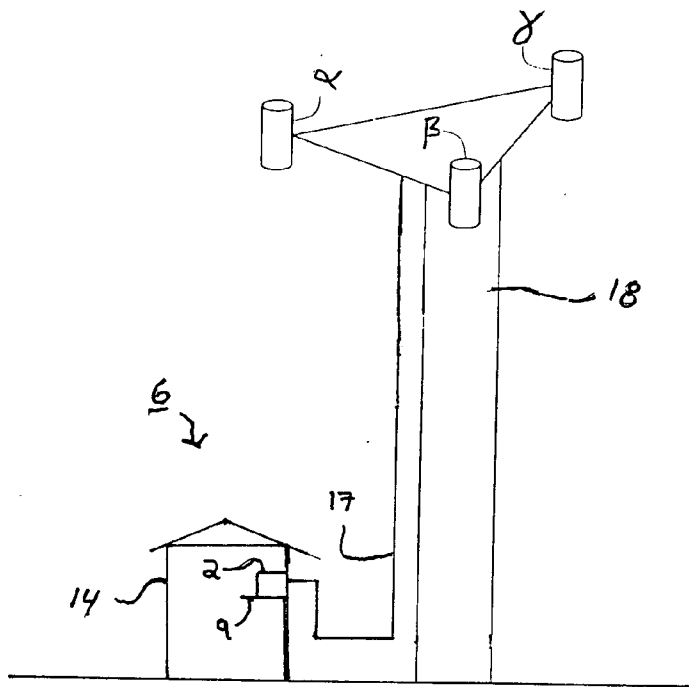

Fig. 3(a)

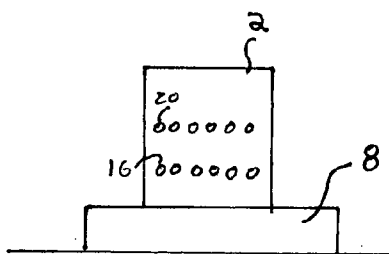

Fig. 3(b)

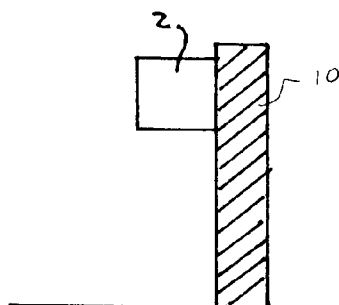

Fig. 3(c)

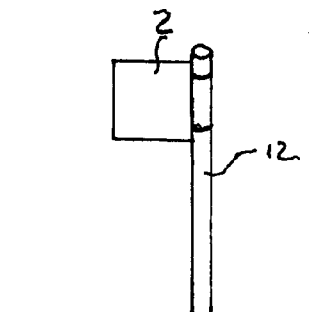

Fig. 3(d)

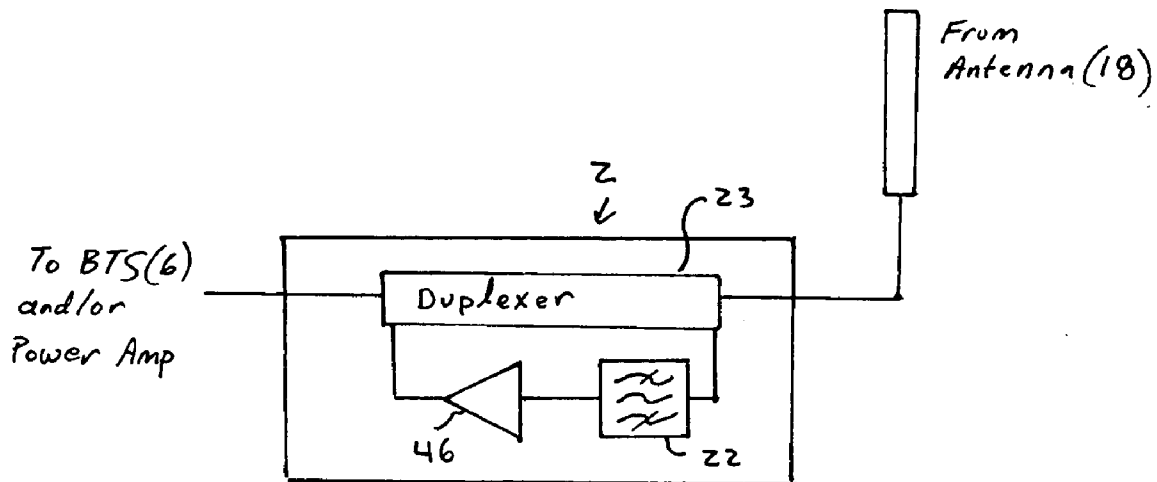

Fig. 4(a)

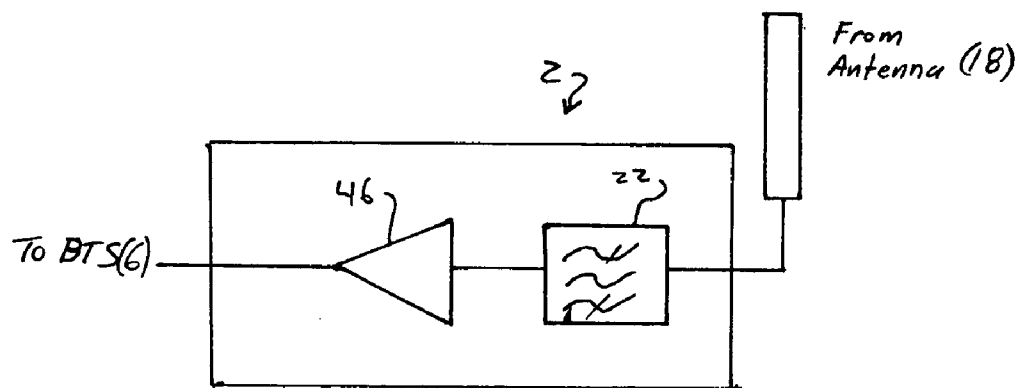

Fig. 4(b)

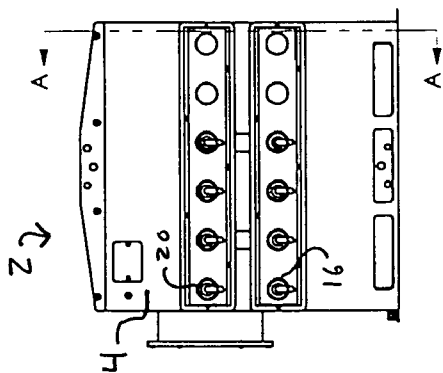

Fig. 5(a)

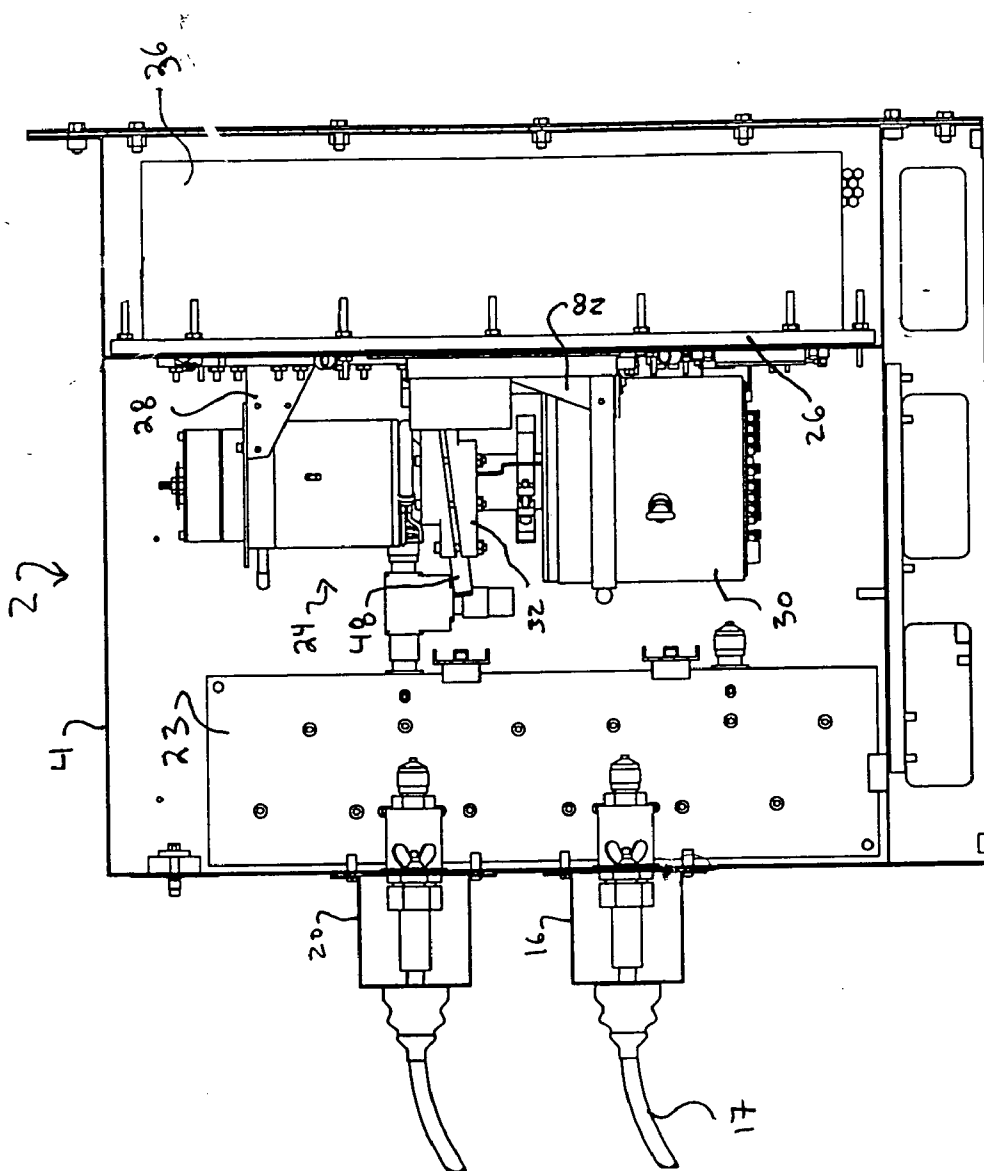

Fig. 5(b)

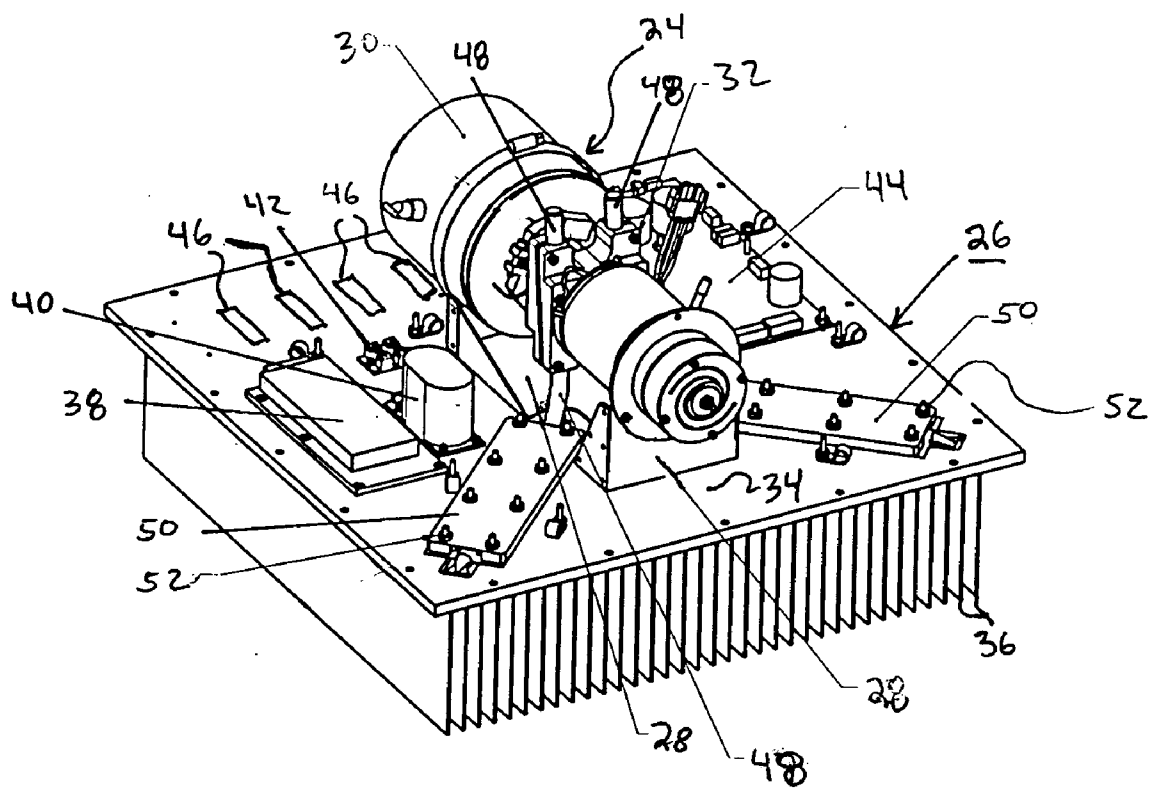

Fig 6(a)

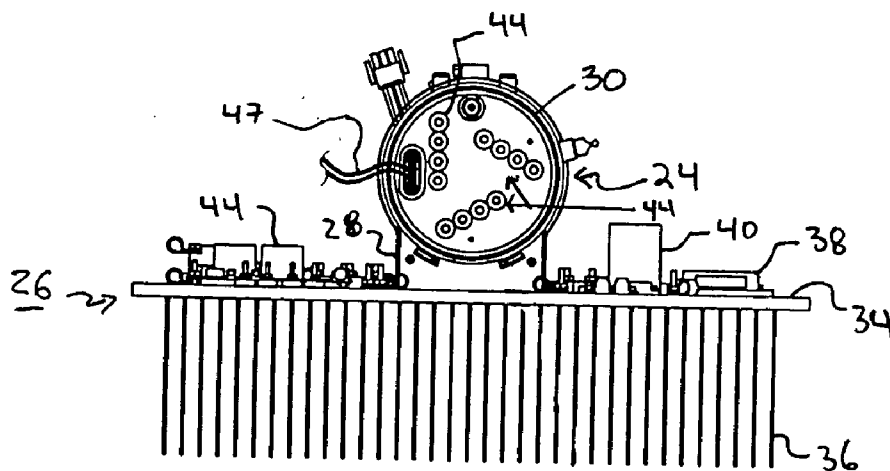

Fig 6(b)

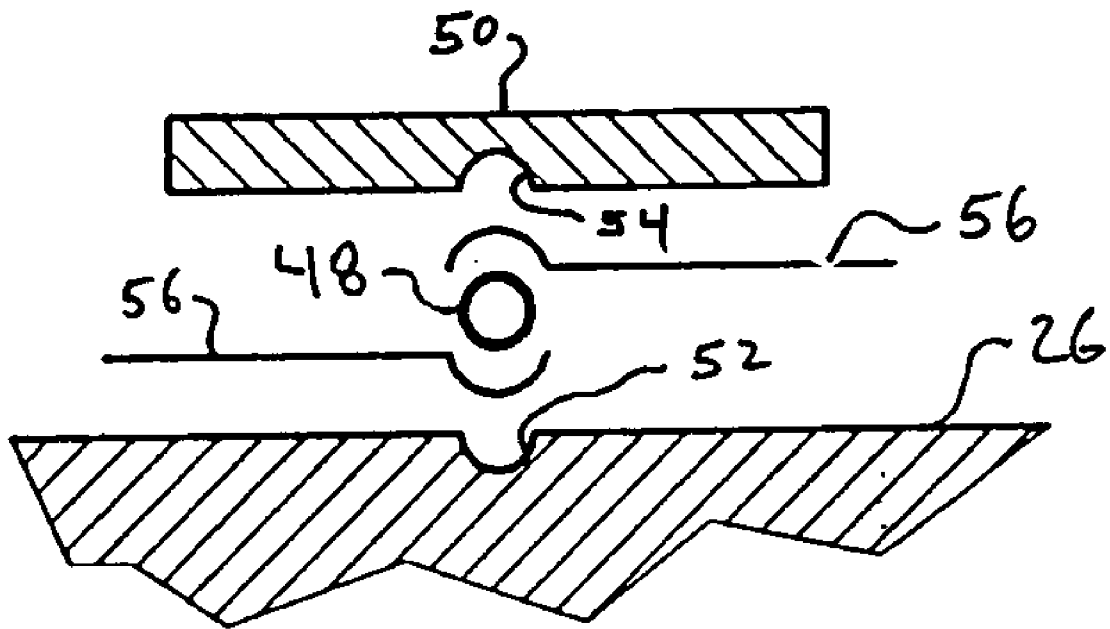
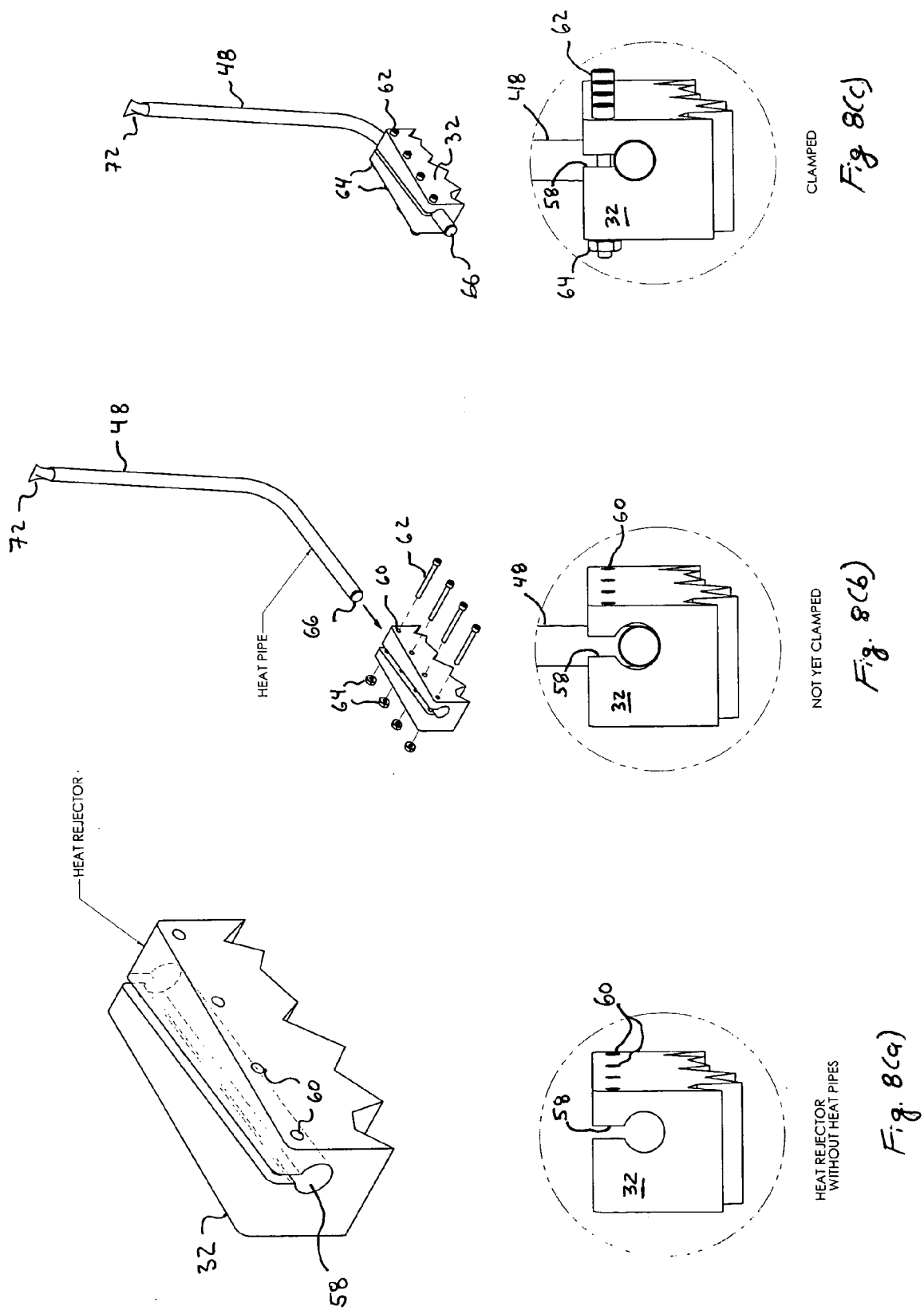

Fig. 7



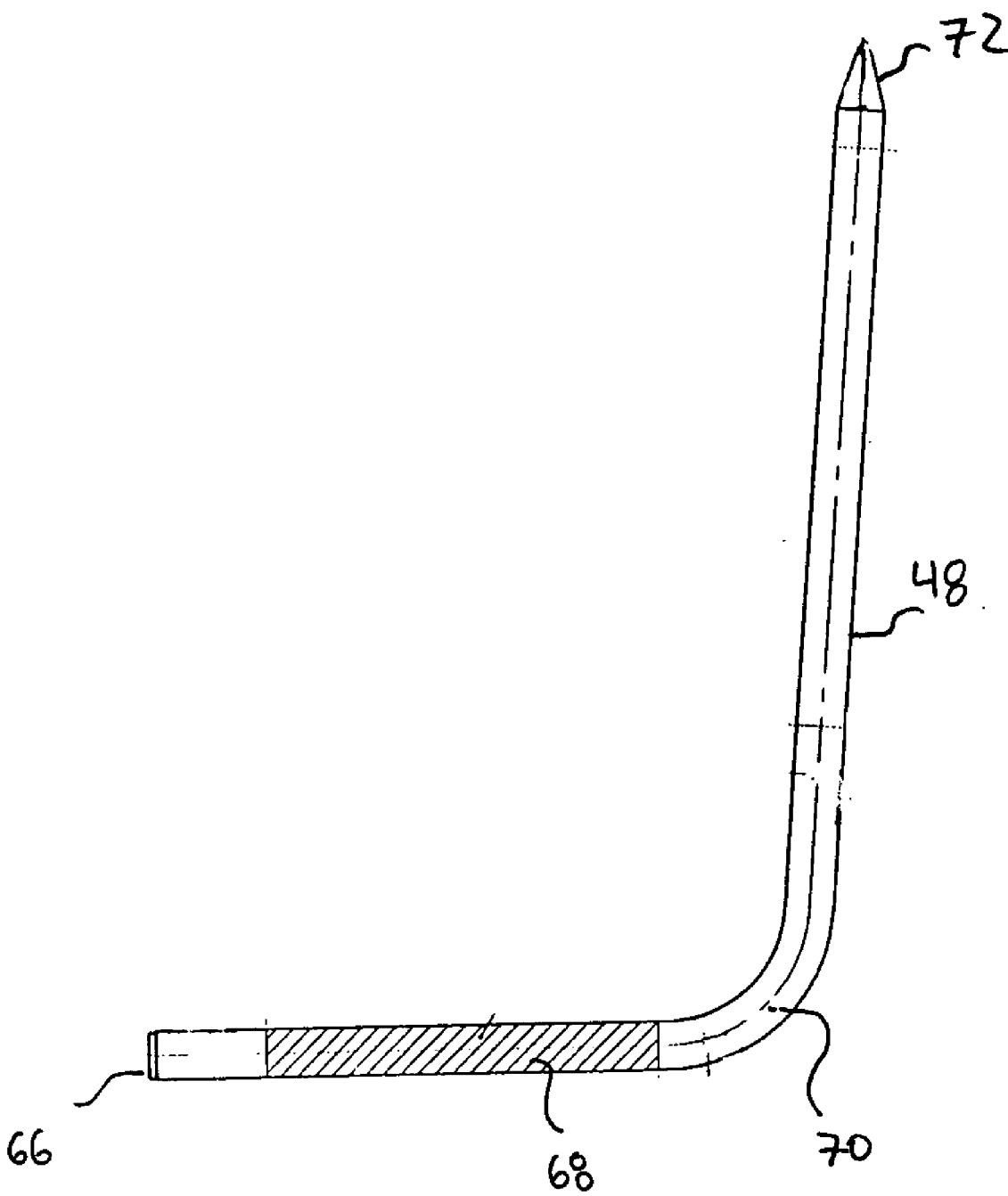

Fig. 9

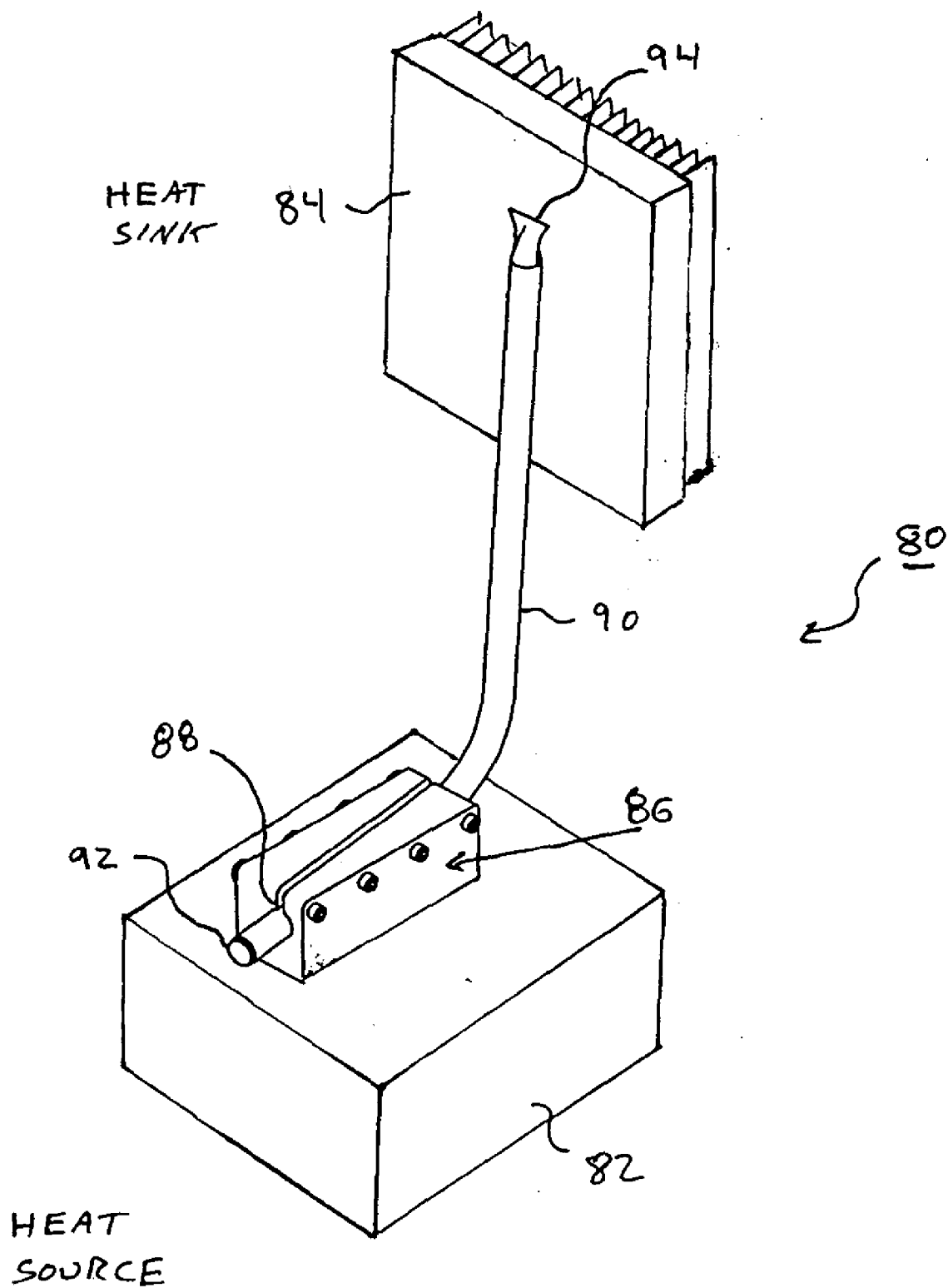

Fig. 10

INTEGRATED CRYOGENIC RECEIVER FRONT-END

STATEMENT REGARDING FEDERALLY SPONSORED RESEARCH AND DEVELOPMENT

[0001] The U.S. Government may have a paid-up license in this invention and a right in limited circumstances to require the patent owner to license others on reasonable terms as provided for by the terms of Contract No. DMEA90-03-C-0302 awarded by the Defense MicroElectronics Activity (DMEA) established by the Department of Defense.

FIELD OF THE INVENTION

[0002] The field of the invention generally relates to high temperature superconducting (HTS) front-end filter systems for use in, for example, wireless applications. The present invention has particular usefulness for wireless PCS carriers but is generally applicable to all wireless front-end applications requiring high sensitivity and high selectivity.

BACKGROUND OF THE INVENTION

[0003] It is known that cryogenically cooled front-end receivers can be used to provide increased sensitivity and selectivity for expanding coverage and reducing interference in noise-limited and interference-limited cell sites. In the context of wireless voice services, cryogenically cooled front-ends provide significant enhancements in network performance including, for example, greater call capacity, fewer coverage gaps both outside and inside buildings, as well as an overall improvement in voice quality.

[0004] Cryogenically cooled front-ends include one or more HTS radio frequency RF filters that, because of their near-zero resistance, provide high selectivity with low loss. In order for the HTS filters to function properly, however, the HTS filters must be cooled to cryogenic temperatures. In order to cool the filters in the front-end, a cryocooler such as a Stirling cycle cryocooler is used to maintain the filters (as well as other associated electronics) at cryogenic temperatures.

[0005] Because of the cryogenic temperatures needed to function properly, cryogenic front-ends must deal with a whole host of thermal management issues. For example, for a cryocooler to function properly, the heat of compression must be efficiently and reliably rejected to the ambient environment. If the heat generated in the compression cycle of the cryocooler cannot be readily rejected, it will result in inefficient cryocooler operation and even cryocooler shut down or failure. Still other components of the front-end device can radiate heat that needs to be transferred to ambient.

[0006] Various methods and devices have been employed to produce cryogenically cooled front-ends. U.S. Pat. No. 6,263,215 discloses a cryoelectronically cooled receiver front-end for mobile radio systems. The receiver front-end consists of a mast mounted portion of the receiver front-end, a compressor located off the mast, and a conduit for delivering cooling fluid from the compressor to the mast-mounted receiver front-end. This system suffers from the limitation that large amounts of energy are wasted by having to pump

cooling fluid from the compressor to the mast-mounted receiver front-end (which may be as high as 200 feet above the ground.)

[0007] U.S. Pat. No. 6,112,526 discloses a HTSC filter system that contains a cryocooler and dewar assembly, a heat dissipation assembly, and at least one heat pipe providing thermal coupling between the heat dissipation assembly and the cryocooler and dewar assembly. In certain embodiments of the system of the '526 patent, one or more fan units may be needed to provide forced air over the heat dissipation assembly.

[0008] It is also known to mount cryogenically cooled front-ends in a structure such as a shed at the bottom of a wireless base station. In this system, the cryogenically cooled front-end is mounted in a rack or cable tray mount. In both options, however, forced convection cooling using a fan unit is required to ensure proper thermal management.

[0009] There thus is a need for a integrated cryogenic receiver front-end that can be located in or adjacent to a wireless base station that does not require a fan unit (either internal or external). There is a further need for a weatherized integrated cryogenic receiver front-end that can be mounted adjacent to a base station in an outdoor environment. There is a further need for an integrated cryogenic receiver front-end that can more efficiently transfer heat generated by power amplifiers, multiplexers, and electronics to ambient.

SUMMARY OF THE INVENTION

[0010] In a first aspect of the invention, a cryogenic receiver front-end includes a heat sink, the heat sink having a mounting surface and a plurality of fins. A cryocooler is mounted to the mounting surface of the heat sink. A heat rejector surrounds the cryocooler and includes a plurality of c-shaped recesses therein. The cryogenic receiver front-end further includes a plurality of heat pipes having a working fluid disposed therein, each heat pipe having first and second ends, the first ends of the plurality of heat pipes disposed in respective c-shaped recesses of the heat rejector, the second ends of the plurality of heat pipes being thermally coupled to the heat sink. An enclosure unit is mounted to the heat sink.

[0011] In a second separate aspect of the invention, a method of dissipating heat from a heat generating component in or adjacent to a base station includes the steps of providing a heat sink, the heat sink being located in or adjacent to a base station. At least one heat generating component is provided. A heat pipe is provided for the at least one heat generating component, the heat pipe having a first end and a second end and a working fluid contained therein, the first end of the heat pipe being thermally coupled to the at least one heat generating component, the second end of the heat pipe being thermally coupled to the heat sink.

[0012] In a third aspect of the invention, a thermally conductive interface between a heat source and a heat sink is provided and includes a heat rejector being thermally coupled with a heat source, the heat rejector including a c-shaped recess therein for receiving one end of a heat pipe having a working fluid therein, the heat sink being thermally coupled to an opposing end of the heat pipe.

[0013] It is an object of the invention to provide a cryogenic receiver front-end that can be located in or adjacent to

a base station that does not require the use of an external fan or similar device to aid in expelling heat to ambient. The cryogenic receiver front-end has a small size and can be mounted either indoors or outdoors. The cryogenic receiver front-end is weather resistant (NEMA-4X compliant) and can be mounted, for example, on a pad, wall, shelf, or pole.

[0014] It is a further object of the invention to provide a thermally conductive interface between a heat source and a heat sink that uses a heat pipe mounted to a novel heat rejector.

[0015] It is yet another object of the invention to provide a method of dissipating heat from heat generating components located in or adjacent to a wireless base station.

[0016] These and further objects of the invention are described in more detail below.

BRIEF DESCRIPTION OF THE DRAWINGS

[0017] FIG. 1 illustrates an end view of the cryogenic receiver front-end according to one embodiment of the invention.

[0018] FIG. 2 is an isometric view of the integrated cryogenic receiver front-end of FIG. 1.

[0019] FIG. 3(a) illustrates a wireless base station having the cryogenic receiver front-end installed inside a structure.

[0020] FIG. 3(b) illustrates the cryogenic receiver front-end mounted to a pad.

[0021] FIG. 3(c) illustrates the cryogenic receiver front-end mounted to a wall.

[0022] FIG. 3(c) illustrates the cryogenic receiver front-end mounted to a pole.

[0023] FIG. 4(a) illustrates the architecture of the cryogenic receiver front-end for the dual duplexed RF path.

[0024] FIG. 4(b) illustrates the architecture of the cryogenic receiver front-end for the simplex RF path.

[0025] FIG. 5(a) illustrates an end view of the cryogenic receiver front-end.

[0026] FIG. 5(b) is a sectional view of the cryogenic receiver front-end taken along the A-A line of FIG. 5(a).

[0027] FIG. 6(a) is an isometric view of the thermal management system used in the cryogenic receiver front-end.

[0028] FIG. 6(b) is an end view of the thermal management system shown in FIG. 6(a).

[0029] FIG. 7 is a detail view of the heat sink, heat pipe, and heat pipe cover.

[0030] FIG. 8(a) illustrates the heat rejector without a heat pipe.

[0031] FIG. 8(b) illustrates the heat rejector of FIG. 8(a) having a heat pipe disposed within the c-shaped recess of the heat rejector. The heat rejector is not clamped around the heat pipe.

[0032] FIG. 8(c) illustrates the heat rejector of FIG. 8(a) having a heat pipe disposed within the c-shaped recess of the heat rejector. The heat rejector is clamped around the heat pipe.

[0033] FIG. 9 illustrates a single heat pipe according to one preferred aspect of the invention.

[0034] FIG. 10 schematically illustrates a thermally conductive interface between a heat source and a heat sink that uses a heat rejector and a heat pipe.

DETAILED DESCRIPTION OF THE PREFERRED EMBODIMENTS

[0035] FIGS. 1 and 2 illustrate a cryogenic receiver front-end 2. The cryogenic receiver front-end 2 includes an enclosure 4 that surrounds and protects the components inside the cryogenic receiver front-end 2. The enclosure 4 is designed to satisfy the NEMA (National Electrical Manufacturers Association) 4X standard. Accordingly, the enclosure 4 is constructed to allow either indoor or outdoor use. The enclosure 4 has a size of approximately 24"W×24"D×24"H.

[0036] For outdoor use, the enclosure provides a reasonable degree of protection against falling dirt, rain, sleet, snow, windblown dust, splashing water, hose-directed water, and ice. The enclosure 4 is preferably made from a corrosion resistant metal.

[0037] With reference now to FIGS. 1, 2, and 3(a), the cryogenic receiver front-end 2 is used in connection with a wireless base station 6 that both receives and transmits wireless data (e.g., voice signals or other data) as part of a wireless network. The cryogenic receiver front-end 2 may be mounted on a pad 8 (FIG. 3(b)), on a shelf 9 (FIG. 3(a)) or wall 10 (FIG. 3(c)), or on a pole 12 (FIG. 3(d)). With respect to mounting the receiver front-end 2 on a pole 12, the pole 12 might include one of the members of the antenna tower located near ground level. The cryogenic receiver front-end 2 is preferably located in or adjacent to a wireless base station 6. With respect to locating the cryogenic receiver front-end 2 in a base station 6, the device is located within some structure 14 which may include a building, shed, or the like. The cryogenic receiver front-end 2 can also be located in an outside environment exposed to ambient (i.e., shown in FIGS. 3(b), 3(c), and 3(d)).

[0038] Referring to FIGS. 1, 2, and 3(a) the cryogenic receiver front-end 2 preferably has one or more weatherized connectors (such as 7-16 DIN type female) that connect to the antenna 18 of a base station 6 via cable 17 (only four are shown in FIGS. 1 and 2 and the connectors 16 are contained in cable boots). The one or more connectors 16 are divided up into three sectors (α , β , γ) for each of the three sectors of the base station 6. The cryogenic receiver front-end 2 also includes one or more weatherized connectors 20 (such as 7-16 DIN type female) that connect to the base station 6 or power amplifier (not shown). Only four connectors 20 are shown in FIGS. 1 and 2 (the connectors 20 are contained in cable boots).

[0039] The cryogenic receiver front-end 2 includes both a dual duplexed RF path shown in FIG. 4(a) as well as a simplex RF path shown FIG. 4(b). A source of either AC or DC voltage (110/220 VAC or 24/48 VDC) is used to power the cryogenic receiver front-end 2. The cryogenic receiver front-end 2 includes one or more HTS filters 22 disposed in a cryogenically cooled environment. HTS filters 22 and associated front-end electronics are known to increase capacity utilization, reduce the number of blocked

calls, extend coverage of an existing base station 6, as well as enable higher data transmission rates. In order to maintain the HTS components at cryogenic temperatures, a cryocooler 24 (shown in FIGS. 5(b), 6(a), and 6(b)) is used to cool the HTS filters 22. The use of a cryocooler 24 poses significant thermal management issues. In order to produce a usable front-end HTS receiver 2, the heat generated from the cryocooler 24 as well as the heat generated in the other components of the HTS front-end device (i.e., heat generated from electrical or RF energy) must be efficiently transferred to the ambient environment.

[0040] In accordance with the invention, the cryogenic receiver front-end 2 uses a unique heat rejection system that is able to passively reject heat to the outside environment without the aid of a fan or other similar device that would enhance convection on or around the device. Preferably, the cryogenic receiver front-end 2 is able to maintain a temperature difference of less than about 20° C. between the temperature of the heat rejector of the cryocooler 22 and the ambient temperature.

[0041] FIG. 5(b) shows an interior view of the cryogenic receiver front-end 2 taken along the line A-A of FIG. 5(a). A multiplexer 23 (which may be a duplexer, or a dual duplexer) is preferably disposed within the enclosure 4 and opposite the heat sink 26. It is possible, however, to locate the multiplexer 23 on the heat sink 26. As seen in FIG. 5(b), a cryocooler 24 is disposed on a heat sink 26 using a carriage assembly 28. The cryocooler 24 includes a dewar 30 that contains the HTS filters 22. A heat rejector 32 surrounds the cryocooler 24 and is used to transfer the heat of compression generated by the cryocooler 24 to ambient as described in more detail below. The cryocooler 24 is preferably a linear cryocooler 24 such as a Stirling cryocooler 24. The invention, however, is not limited to a particular type of cryocooler 24.

[0042] As seen in FIG. 5(b), the heat sink 26 and fins 36 are oriented vertically within the enclosure 4. The vertical orientation is used to create a chimney effect with hot air rising between adjacent fins 36 to the outside environment.

[0043] FIGS. 6(a) and 6(b) show a detailed view of the cryocooler 24 and the heat rejection system used to transfer heat to ambient. The heat rejection system includes a heat sink 26 having a mounting surface 34 and plurality of fins 36. The cryocooler 24 is mounted to the mounting surface 34 of the heat sink 26 by the carriage assembly 28. Preferably, the heat sink 26 is made from a thermally conductive material such as aluminum. One preferred material for the heat sink 26 and fins 36 is aluminum alloy 6063. The fins 36 are preferably swaged to optimize heat transfer for natural heat convection.

[0044] Additional electronic components of the cryogenic receiver front-end 2 are also directly mounted to the mounting surface 34 of the heat sink 26. These components include the power supply 38, power converter 40, diode 42 (for power system protection), DSP board 44, and one or more RF components such as amplifiers 46 (six amplifiers in total are shown). The additional RF components may comprise additional amplification, such as second stage amplification, mixing devices for frequency conversion and/or IF signal processing and analogue to digital converter (A to D converter). The electronic components are advantageously mounted directly to the heat sink 26 in order to more

efficiently transfer heat generated thereby to ambient. Heat generated by the various electronic components is transferred to the plate portion of the heat sink 26 and then to the fins 36.

[0045] FIG. 6(b) shows an end view of the dewar 30 of the cryocooler 24. Electrical connectors 44 (12 in total—6 input and 6 output) permit electrical communication with the six HTS filters 22 contained within the dewar 30. A dewar harness 47 gives electrical access to the inside of the dewar 30 for a cold bypass for each of the six HTS filters 22 contained within the dewar, temperature sensors for monitoring the temperature of the dewar 30/HTS filters 22, ground, and LNAs. An external (non-cryogenically cooled) bypass might also be used.

[0046] A thermally conductive interface is provided between the heat rejector 32 of the cryocooler 24 and the heat sink 26. In the preferred embodiment, a plurality of heat pipes 48 are used to efficiently transfer heat from the heat rejector 32 to the heat sink 26. As seen in FIG. 6(a), two separate heat pipes 48 are used to transfer heat to the heat sink 26. The heat pipes 48 are thermally coupled to the heat rejector 32 using a pliable c-shaped recess (shown in detail in FIGS. 8(a), 8(b), and 8(c)) for receiving ends of the heat pipes 48. The heat pipes 48 are bent into an elbow shape such that opposing ends of the heat pipes 48 can make thermal contact with the heat sink 26.

[0047] Referring to FIG. 6(a), opposing ends of heat pipes 48 are thermally coupled to the heat sink 26 by using a pair of heat pipe covers 50. The heat pipe covers 50 pinch the heat pipes 48 between the heat sink 26 and the underside of the heat pipe covers 50. Bolts and associated nuts 52 are used to secure the heat pipe covers 50 to the heat sink 26. Preferably, the heat pipe covers 50 are formed from oxygen free high conduction (OFHC) copper.

[0048] FIG. 7 shows an end view of the mating arrangement between the heat pipe cover 50 and the heat sink 26. As seen in FIG. 7, a hemispherical groove 52 is formed in the heat sink 26. Similarly, another hemispherical groove 54 is formed in the underside of the heat pipe cover 50. A thermally conductive compound 56 is applied at the interface between the heat sink 26 and heat pipe cover 50 to improve the thermal transfer efficiency between the two components. Preferably, a thermally conductive compound such as THERMAGON T-PCM 910 (a non-reinforced boron nitride filled film) is used.

[0049] FIGS. 8(a) illustrates one side of the heat rejector 32 used to transfer heat from the cryocooler 24. The heat rejector 32 is formed from a thermally conductive metal such as, for example, copper. Preferably, the thermally conductive metal is annealed OFHC copper. In a preferred method of forming the heat rejector 32 half hard or full hard OFHC copper is annealed (softened) by brazing the copper to at least 450° C. The annealed copper that results is particularly pliable and can form an excellent thermal contact with the heat pipes 48.

[0050] The heat rejector 32 includes a c-shaped recess 58 that receives an end of the heat pipe 48. The heat rejector 32 also includes a plurality of holes 60 that can accept bolts 62 (FIG. 8(b)) used to clamp the c-shaped recess 58 around the heat pipe 48.

[0051] Referring now to FIG. 8(b), one end of the heat pipe 48 is inserted into the c-shaped recess 58. As seen in the

end view of FIG. 8(b), in the non-clamped position, there is a small gap between the outer surface of the heat pipe 48 and the inner surface of the c-shaped recess 58. The c-shaped recess 58 is then clamped around the outer surface of the heat pipe 48 by inserting the bolts 62 into the corresponding holes 60 in the heat rejector 32 and tightening nuts 64. An alternative to using bolts 62 and nuts 64 would be to use screws in threaded holes within the heat rejector 32. It is preferable, however, to use bolts 62 and nuts 64 to prevent the possibility of stripping the threads in the heat rejector 32 during tightening.

[0052] FIG. 8(c) illustrates the c-shaped recess 58 in the clamped state. In the clamped state, there is no gap between the outer surface of the heat pipe 48 and the inner surface of the c-shaped recess 58 as the recess has fully conformed to the outer surface of the heat pipe 48. It should be understood that the pliable nature of the c-shaped recess 58 allows excellent thermal contact between the heat pipe 48 and the heat rejector 32 even if there are small variations or imperfections in the exterior surface of the heat pipe 48.

[0053] FIG. 9 illustrates a heat pipe 48 according to a preferred aspect of the invention. The heat pipe 48 is preferably formed from 0.5" OFHC copper. As seen in FIG. 9, the heat pipe 48 is bent into an elbow shape. For the embodiment with the cryogenic receiver front-end 2, the heat pipe 48 is preferably bent to an angle greater than 90° to utilize gravity during the liquidation portion of the heat pipe 48 cycle. A plug 66 is formed in the end of the heat pipe 48 that is secured to the heat rejector 32. The plug is formed from a material that is non-reactive with the working fluid 70. The plug 66 fits within the internal diameter of the heat pipe 48 so as not to interfere with the close fit formed between the heat pipe 48 and the heat rejector 32.

[0054] Also located inside the evaporator section of the heat pipe 48 (the section of heat pipe 48 secured within the heat rejector 32) is a wire mesh or screen 68. The evaporator section is retained in the c-shaped recess 58 when the heat pipe 48 is secured to the heat rejector 32. A working fluid 70 is located inside the heat pipe 48 and is used to transfer heat from the evaporator portion to the cooler condenser portion secured to the heat sink 26. In a preferred aspect of the invention, the working fluid 70 is methanol. However, other working fluids such as ammonia, water, nitrogen, neon, and ethane can be used. A pinch 72 (see also FIGS. 8(b) and 8(c)) is formed at the end of the heat pipe 48 opposite the end having the plug 66. The pinch 72 is formed after filing the heat pipe 48 with the working fluid 70. An epoxy (not shown) is preferably placed over the pinch 72 to protect the pinched zone from damage that might cause working fluid 70 to leak out.

[0055] The use of one or more heat pipes 48 in the cryogenic receiver front-end 2 provides a thermal management system that is able to passively reject heat to ambient without the aid of a fan. Moreover, the heat pipes 48 are fully contained within the enclosure 4 (i.e., the heat pipes 48 do not pass through the walls of the enclosure 4) and therefore do not jeopardize the environmental protection quality of the cryogenic receiver front-end 2.

[0056] While the preferred embodiment of the invention uses a plurality of heat pipes 48 to transfer the heat of compression generated from a cryocooler 24, it should be understood that the heat rejector 32 and heat pipe(s) 48 may

be used to dissipate heat from any number of heat generating components that are in a cryogenic receiver front-end 2 located in or adjacent to a base station 6. In addition, it may be the case that a single heat pipe 48 provides sufficient heat transfer from a heat generating component to a heat sink.

[0057] FIG. 10 broadly illustrates an embodiment of a thermally conductive interface 80 used to transfer heat from a heat source 82 to a heat sink 84. The heat source 82 may include, for example, amplifier(s), multiplexer(s), duplexers(s), a power supply, a power converter, and control circuitry. In the broadest sense of the invention, the heat source 82 may include any device that generates heat either from electrical energy or RF energy.

[0058] The heat source 82 is preferably thermally coupled to a heat rejector 86 having at least one c-shaped recess 88 of the type described in detail above. A heat pipe 90 (or multiple heat pipes 90 if more than one c-shaped recess 88 is present) is disposed inside the c-shaped recess 88 in a clamped arrangement thereby thermally coupling the heat pipe 90 to the heat rejector 86. The heat pipe 90 is thermally coupled at the other end to the heat sink 84. The heat pipe 90 may be thermally coupled to the heat sink 84 using heat pipe covers 50 as described above (not shown in FIG. 10) or any other arrangement that forms good thermal contact between the heat pipe 90 and the heat sink 84.

[0059] The heat pipe 90 may include a plug 92 at one end and a pinch 94 at the other end to retain a working fluid therein (not shown). In FIG. 10, the heat pipe 90 is shown having an elbow shape although other geometries (even straight) can be employed. It should be understood that the invention is not limited to the specific construction of the heat pipe 90 described above as other heat pipe 90 constructions are also contemplated to fall within scope of the invention.

[0060] While the invention is susceptible to various modifications, and alternative forms, specific examples thereof have been shown in the drawings and are herein described in detail. It should be understood, however, that the invention is not to be limited to the particular forms or methods disclosed, but to the contrary, the invention is to cover all modifications, equivalents and alternatives falling within the spirit and scope of the appended claims.

What is claimed is:

1. A cryogenic receiver front-end comprising
 - a heat sink, the heat sink comprising a mounting surface and a plurality of fins;
 - a cryocooler mounted to the mounting surface of the heat sink;
 - a heat rejector surrounding the cryocooler, the heat rejector including a plurality of c-shaped recesses therein;
 - a plurality of heat pipes, each heat pipe having first and second ends, the first ends of the plurality of heat pipes disposed in respective c-shaped recesses of the heat rejector, the second ends of the plurality of heat pipes being thermally coupled to the heat sink, the plurality of heat pipes having a working fluid disposed therein; and
 - an enclosure unit mounted to the heat sink.

2. The thermally conductive interface of claim 1, wherein the heat rejector is made of a metal.

3. The cryogenic receiver front-end of claim 2, the heat rejector being formed from annealed copper.

4. The cryogenic receiver front-end of claim 1, the plurality of heat pipes being formed from OFHC copper.

5. The cryogenic receiver front-end of claim 1, wherein the enclosure unit satisfies the NEMA-4X standard.

6. The cryogenic receiver front-end of claim 1, wherein the cryogenic receiver front-end is disposed inside a structure.

7. The cryogenic receiver front-end of claim 1, wherein the cryogenic receiver front-end is disposed in an outside environment.

8. The cryogenic receiver front-end of claim 1, wherein the cryogenic receiver front-end is disposed in or adjacent to a base station.

9. The cryogenic receiver front-end of claim 1, wherein the cryogenic receiver front-end is mounted to a pad.

10. The cryogenic receiver front-end of claim 1, wherein the cryogenic receiver front-end is mounted to a wall.

11. The cryogenic receiver front-end of claim 1, wherein the cryogenic receiver front-end is mounted to a pole.

12. The cryogenic receiver front-end of claim 1, wherein the working fluid is selected from the group consisting of methanol, ammonia, water, nitrogen, neon, and ethane.

13. A method of dissipating heat from a heat generating component located in or adjacent to a base station, the method comprising the steps of:

providing a heat sink, the heat sink being located in or adjacent to a base station;

providing at least one heat generating component;

providing a heat pipe for the at least one heat generating component, the heat pipe having a first and a second end and a working fluid contained therein, the first end of the heat pipe being thermally coupled to the at least one heat generating component, the second end of the heat pipe being thermally coupled to the heat sink.

14. The method of claim 13, wherein the heat sink comprises a plate having a plurality of fins located thereon.

15. The method of claim 13, wherein the heat generating component is selected from the group consisting of amplifier, multiplexer, power supply, power converter, and control circuitry.

16. The method of claim 13, wherein the heat pipe is thermally coupled to the at least one heat generating component using a heat rejector including a c-shaped recesses therein, the first end of the heat pipe being disposed within the c-shaped recess.

17. The method claim 13, wherein the working fluid is selected from the group consisting of methanol, ammonia, water, nitrogen, neon, and ethane.

18. The method of claim 13, wherein the heat pipe is fully enclosed within an enclosure surrounding the at least one heat generating component.

19. A thermally conductive interface between a heat source and a heat sink comprising:

a heat rejector being thermally coupled with a heat source, the heat rejector including a c-shaped recess therein for receiving one end of a heat pipe having a working fluid therein, the heat sink being thermally coupled to an opposing end of the heat pipe.

20. The thermally conductive interface of claim 19, wherein the heat rejector is made of a metal.

21. The thermally conductive interface of claim 20, wherein the heat rejector is made of annealed copper.

22. The thermally conductive interface of claim 19, wherein the heat source is a cryocooler.

23. The thermally conductive interface of claim 19, wherein the heat source is selected from the group consisting of amplifier, multiplexer, power supply, power converter, and control circuitry.

24. The thermally conductive interface of claim 19, further comprising means for clamping the c-shaped recess.

* * * * *