

# SuperLink™ Rx

## Operation and Installation Manual



# TABLE OF CONTENTS

Chapter 1 Introduction .....	1
Overview .....	1
About this Manual .....	1
General Safety .....	3
Warnings, Cautions, and Notes .....	3
Electrostatic Discharge .....	3
Technical Assistance .....	3
Chapter 2 Using the SuperLink Rx .....	5
Equipment Configurations .....	5
Cascade Option .....	6
Overlay Model .....	6
Functional Description .....	7
RF Signal Flow .....	7
Control .....	8
Cryogenic Cooling .....	8
Power .....	8
Indicators, Connectors, and Controls .....	10
Front View of the SuperLink Rx .....	10
Rear Panel of the SuperLink Rx .....	10
Model Number Identification .....	13
Chapter 3 Unpacking the SuperLink Rx .....	15
Reviewing the Contents of the SuperLink Rx Package .....	15
Unpacking the SuperLink Rx .....	16
Instructions for Return Shipment .....	17
Chapter 4 Installation Requirements .....	19
Overview .....	19
SuperLink Rx Requirements .....	19
Site Requirements .....	19
Required Installation Tools and Materials .....	20
Required Functional Checks Test Equipment .....	21
Reviewing PC System Requirements .....	21
Chapter 5 Installing the SuperLink Rx .....	23
Overview .....	23
SuperLink Rx Installation Procedures .....	23
Installing the Java Runtime Environment .....	23
Installing the System Status Portal .....	27
Mounting the SuperLink Rx on the Equipment Rack .....	30
Connecting the Chassis Ground .....	31
Connecting the Power Wire .....	31
Connecting the Alarm Relay .....	32
Performing Power Up/Cooldown .....	33
Performing Functional Checks .....	35

Connecting RF Cables .....	42
Connecting RF Cables (Overlay).....	43
Chapter 6 Troubleshooting Tips .....	45
Overview.....	45
Installation Troubleshooting.....	46
Operation Troubleshooting.....	51
Chapter 7 Periodic Visual Inspection .....	53
Visual Inspection Recommendations.....	53
Cleaning the Air Filter .....	54
Appendix A Using the System Status Portal .....	55
Overview.....	55
System Status Portal Interface .....	56
Main Screen Buttons.....	56
Menu Bar .....	57
Status View .....	59
Fault Records View.....	65
Appendix B SuperLink Rx Specifications.....	69
Appendix C Receive Path Gain/Loss Calculator.....	71
Index .....	73

## LIST OF FIGURES

Figure 1. Typical Base Station Diagram for the SuperLink Rx, Cascade Option .....	5
Figure 2. Signal Flow Block Diagram, Cascade.....	6
Figure 3. System Integration Block Diagram, Overlay Model.....	7
Figure 4. Functional Block Diagram .....	9
Figure 5. Front Panel Indicators.....	10
Figure 6. 2-Pak Rear Panel Connectors and Controls.....	11
Figure 7. 6-Pak Rear Panel Connectors and Controls.....	11
Figure 8. 2-Pak Rear Panel Connectors and Controls, Overlay.....	12
Figure 9. 6-Pak Rear Panel Connectors and Controls, Overlay.....	12
Figure 10. Model Numbering .....	13
Figure 11. Foam Packaging Installation .....	18
Figure 12. Example of SuperLink Rx with 23-inch Rack Mount Brackets, Center-Mounted .....	31
Figure 13. Alarm Relay in Normal and Alarm States.....	32
Figure 14. PC Connection to the SuperLink Rx .....	35
Figure 15. Test Generator Calibration Reference Level Measurement Diagram .....	39
Figure 16. Gain Test Setup .....	41
Figure 17. Cabling Diagram, Cascade and Overlay .....	44
Figure 18. Air Filter Location.....	54
Figure 19. Removing the Air Filter Retainer .....	54

## LIST OF TABLES

Table 1. Front Panel Indicators and Controls .....	10
Table 2. Rear Panel Connectors and Controls .....	13
Table 3. Equipment Supplied.....	15
Table 4. Hand Tools Required.....	20
Table 5. Materials Required.....	20
Table 6. Test Equipment Required .....	21
Table 7. SuperLink Rx Internal States and Status .....	34
Table 8. SuperLink Rx Specifications .....	69



---

# Chapter 1 Introduction

---

## Overview

---

The SuperLink Rx (SL Rx) is a highly selective and sensitive RF filter used in the receive path of wireless base stations. The SL Rx eliminates the trade-off between selectivity and sensitivity. The superior performance of the SL Rx enables wireless service providers to enhance customer satisfaction and increase their subscriber base by improving the quality of voice and data transmissions of their networks.

Some advantages of incorporating a SL Rx in a wireless telecommunications network include:

- Improved receiver noise figure
- Improved out-of-band signal rejection
- Stable sensitivity (cellular site performance not impacted by out-of-band interference)
- Low power consumption
- Virtually maintenance free operation
- Convenient base station installation
- Worry-free uplink enhancement

## About this Manual

---

The *SuperLink Rx Operation and Installation manual* describes the 2-Pak and 6-Pak SL Rx. In addition, this manual describes the overlay model for the 2-Pak and 6-Pak SL Rx. Detailed information such as installation requirements, testing procedures, and troubleshooting tips will assist you with the proper installation and operation of the SL Rx.

Review the manual carefully for proper installation and operation of your SL Rx system. The following summary provides brief information about the chapters and appendices.




<b>Chapter</b>	<b>Title</b>	<b>Description</b>
1	Introduction	States the purpose of the manual. Provides general information about the manual that you need to know.
2	Using the SuperLink Rx	Describes the role of the SL Rx in a typical wireless system. Provides information on SL Rx equipment configurations and functional descriptions.
3	Unpacking the SuperLink Rx	Provides detailed information about unpacking the SL Rx.
4	Installation Requirements	Lists the tools, materials, and test equipment requirements for SL Rx installation.
5	Installing the SuperLink Rx	Provides the following information for installing the SL Rx: installing the software programs, mounting the system, connecting the power and alarm wires, performing power up/cooldown, performing functional checks, and connecting RF cables.
6	Troubleshooting Tips	Provides basic troubleshooting procedures for problems that may occur during installation and operation.
7	Periodic Visual Inspection	Provides information about inspecting the SL Rx on a periodic basis.
Appendix A	Using the System Status Portal	Explains the STI System Status Portal interface.
Appendix B	SuperLink Rx Specifications	Provides detailed information about the SL Rx specifications.
Appendix C	Receive Path Gain/Loss Calculator	Provides a table to record channel gain/loss values as you conduct the Receive Path Gain test. This Appendix is also available as a Microsoft <sup>®</sup> Excel file in the <b>SuperLink Rx Operation and Installation Manual folder</b> located on the STI CD.

# General Safety

---


## Warnings, Cautions, and Notes

Warnings, cautions, and notes are used throughout the manual. Review the significance of each:

- |   |  |
|---|--|
|  | A warning denotes a hazard to personnel. A warning calls attention to a procedure, which if not correctly performed or adhered to, could result in injury to personnel.    |
|  | A caution denotes a hazard to equipment. A caution calls attention to a procedure, which if not correctly performed or adhered to, could result in damage to the equipment |
|  | A note calls attention to a procedure for informational purposes only.   |

## Electrostatic Discharge


The SL Rx contains components that are subject to damage from electrostatic discharge (ESD). Improper handling of the RF connectors, located on the rear panel of the SL Rx chassis, can result in ESD damage. Ensure that you adhere to all appropriate ESD precautions when handling components mounted at the rear of the system. The following caution appears throughout the manual during procedures in which the SL Rx may be subject to damage by ESD.

- |   |   |
|---|---|
|  | The SL Rx contains components that are subject to damage from electrostatic discharge (ESD). Take precautionary measures when handling components mounted at the rear of the equipment. |
|---|---|

## Technical Assistance

---

For technical assistance, call the STI Customer Service Hotline (CS-Hotline): 800.727.3648.

- |   |   |
|---|---|
|  | “CS-Hotline” refers to the STI Customer Service Hotline. For your convenience, the CS-Hotline number is located on the bottom of each page throughout the manual. |
|---|---|



## Warranty

---

On a standard basis, Superconductor Technologies Inc. (STI) warrants its SuperLink Rx to be free from any defect in material and workmanship for a period of one (1) year from the date of shipment.

STI's sole obligation under this warranty is to repair or replace the SuperLink Rx or any part thereof, which proves to be defective after inspection by STI. The warranty for the repaired or replaced SuperLink Rx is the un-expired warranty period of the original SuperLink Rx, or ninety (90) days whichever is greater. This warranty does not apply to any SuperLink Rx that has been disassembled, modified, subjected to unusual electrical or physical stress, misuse, neglect, excessive deterioration or erosion, abuse, accident, unauthorized repair, improper installation, or use in any way that is contrary to the instructions set forth herein.

STI is not liable for any indirect, incidental, consequential or special damages, including without limitation, lost profits and cost of procurement of substitute goods.

This warranty is the full extent of obligation and liability assumed by STI with respect to its SuperLink Rx. STI neither assumes nor authorizes any other person to assume for it any other obligations or liability in connection with the sale, installation or use of its SuperLink Rx.

---

# Chapter 2 Using the SuperLink Rx

---

## Equipment Configurations

---

The SL Rx is available in United States A and B Cellular Frequency Bands. Both A-Band and B-Band SL Rx systems are available in 2-Pak and 6-Pak RF receiver configurations:

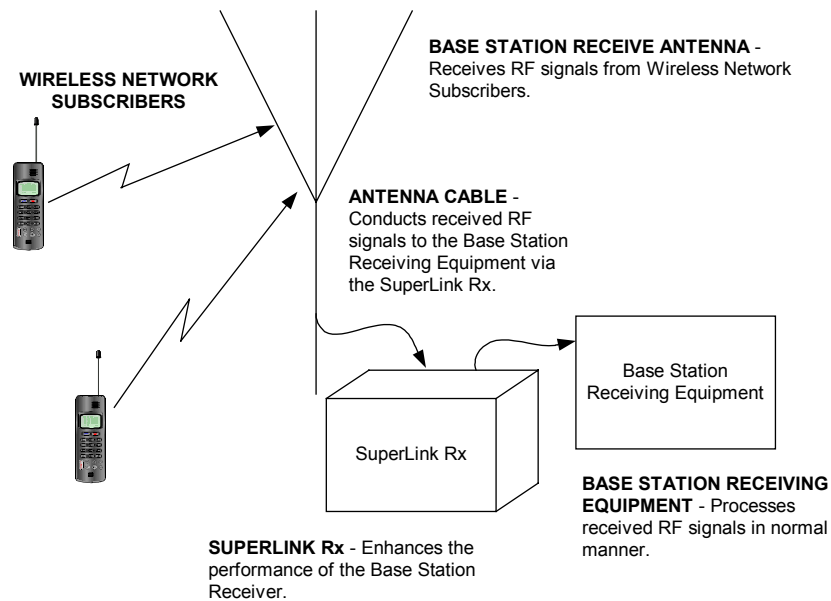
- The 2-Pak SL Rx system provides two RF receive paths, and operates in a cellular system that uses omni-directional antennas, one main, and one diversity.
- The 6-Pak SL Rx system is designed for a cellular system that uses three antenna sectors, each consisting of one main and one diversity antenna.

Two RF configurations are available for both 2-Pak and 6-Pak SL Rx systems:

- Cascade option
- Variable Gain option (VGO)

Additionally, the SL Rx system is configurable as an Overlay. See the “Overlay Model” section on page 6 for more information.

Figure 1 shows a typical wireless telecommunications base station diagram with a SL Rx system.

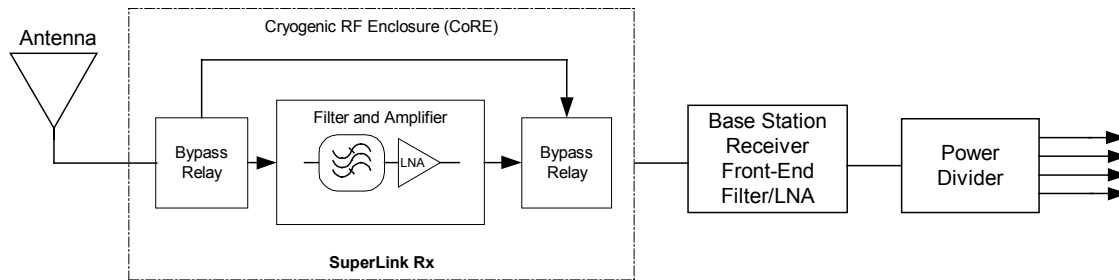


**Note:** Single RF path shown for simplicity.

**Figure 1. Typical Base Station Diagram for the SuperLink Rx, Cascade Option**

## Cascade Option

The SL Rx system is a Filter-Amplifier that connects in-line (cascade) with the existing receiver equipment. Figure 2 shows a Cascade system connected with a base station sector. The block diagram shows the Bypass RF path, which provides pre-SL Rx performance if the Filter-Amplifier should develop a problem. The Filter-Amplifier connects directly to the antenna cable, and provides a clear, low noise signal to the receiver.



Note: Single RF path shown for simplicity.

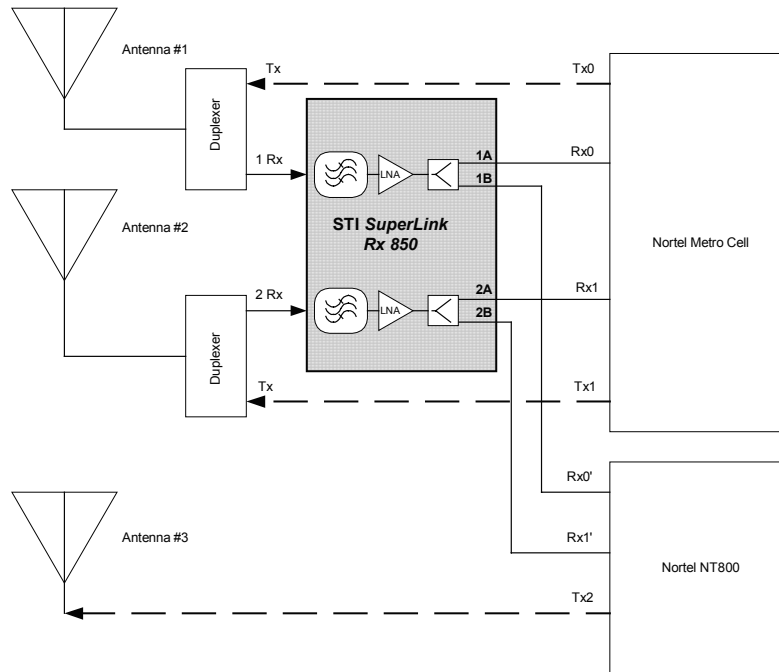
Figure 2. Signal Flow Block Diagram, Cascade

## Overlay Model

The Overlay model solves the problem of adding a new base station to an existing base station. This SL Rx system simplifies an overlay without degrading or interfering with the incumbent base station, in addition to providing SL Rx benefits to both technologies. To achieve maximum performance, the Overlay model uses a power divider that provides two separate outputs for every input as shown in Figure 3. Each path provides a modest positive gain and improvement in noise figure. Figure 3 shows an example of a system integration block diagram for one sector of a base station (Nortel Metro Cell (CDMA) and Nortel NT800 (TDMA)).

Benefits of using the Overlay model include:

- Only one SL Rx system is required for each sectored site.
- Noise figure improvement.
- Enhanced interference protection.
- Sensitivity improvement for both new and existing base stations.



**Figure 3. System Integration Block Diagram, Overlay Model**

## Functional Description

The functional areas of the SL Rx are described in the following paragraphs. See Figure 4 for a functional block diagram of the SL Rx.

### RF Signal Flow

RF signals from the Antenna are connected to the Cryogenic RF Enclosure (CoRE). Inside the CoRE the signals connect to the first Bypass Relay. In normal operation the signals are connected to the band-specific superconducting filter and a Low Noise Amplifier (LNA) for each RF path. From the LNA, the signals go to the second Bypass Relay and then out of the CoRE to the connector panel on the rear of the SL Rx.

If a problem develops during normal operation, such as the CoRE dropping out of the operating temperature, or a loss of power, the system will automatically switch into Bypass mode. In Bypass mode, the RF signals from the Antenna are routed through the initial RF Bypass Relay, bypassing the SL Rx Filter-Amplifier and into the second RF Bypass Relay. For SL Rx systems, in both SuperLink and Bypass modes of operation, the RF signals from the second RF Bypass Relay and are routed to the base station receiver.

The SL Rx is set to Bypass mode on power up. In Bypass mode, both Bypass Relays switch together and connect the input to the output through a stripline circuit that bypasses the filter and LNA. The SL Rx system will automatically switch to SuperLink mode (Regulate state) when the CoRE has reached operating temperature. In SuperLink mode (Regulate state), the CoRE circuits provide highly selective filtering along with ~13 dB gain in each RF path.

## Control

The Digital Signal Processor (DSP) provides the SL Rx control and performance monitoring function. The DSP monitors:

- Input voltage from the Power Supply
- Driver power for the Cooling Motor Driver
- CoRE temperature from the Thermal Sensor Interface
- LNA current

If input voltage drops or rises to an unacceptable level the DSP will cause the SL Rx to switch into the Fault Bypass mode and, at the same time, activate the alarm relay. Signals from the alarm relay are available for connection to a base station alarm system. The **BYPASS** LED, located on the SL Rx front panel, will illuminate RED (flashing or steady) to indicate Bypass mode.

The DSP senses variations in driver current. If the motor driver current levels move to an unacceptable level the DSP will cause the SL Rx to switch into the Shutdown mode and, at the same time, activate the alarm relay as previously mentioned.

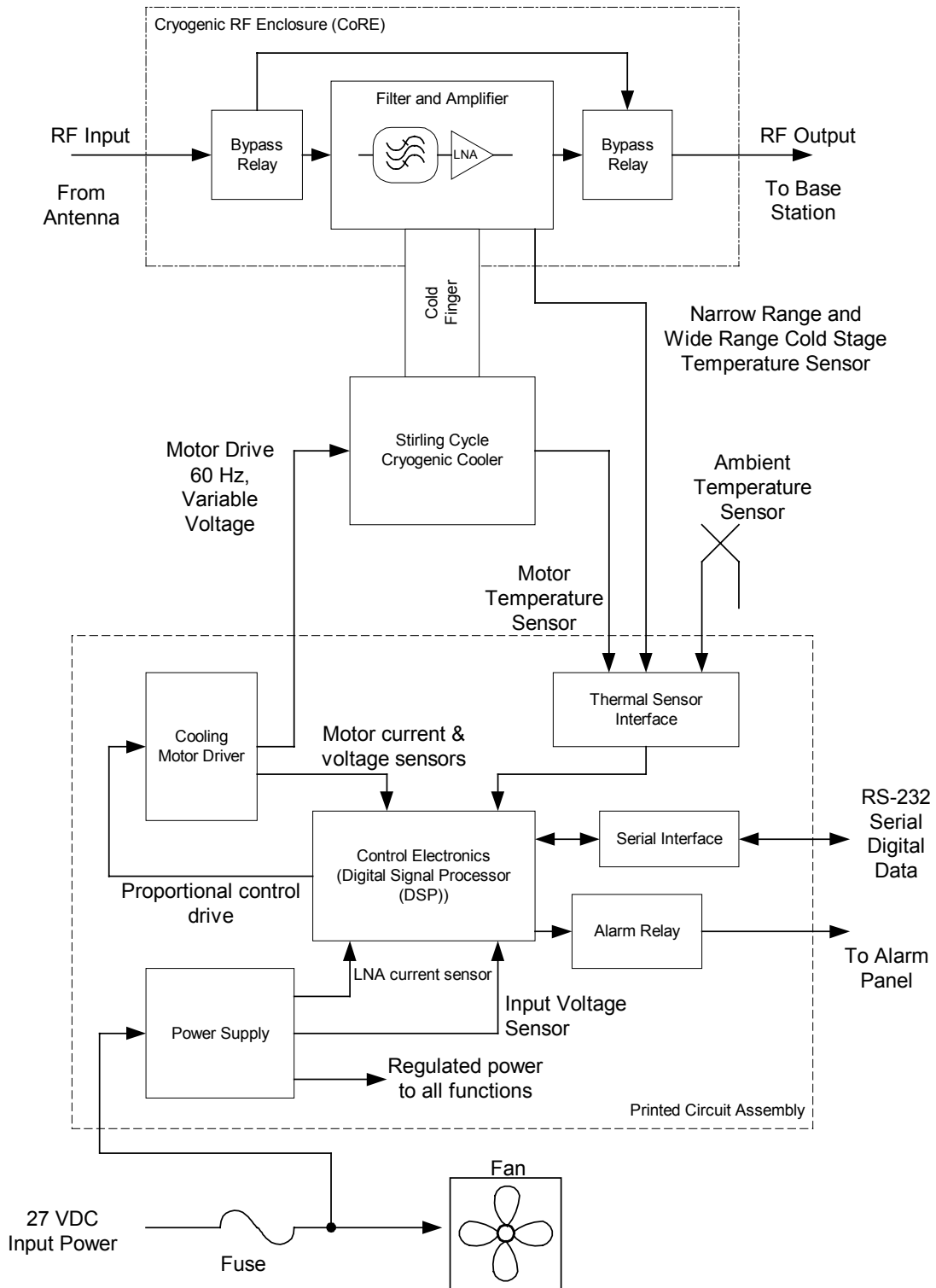
The DSP controls the temperature of the CoRE. The Thermal Sensor Interface routes multiplexed sensor signals to the DSP. Correction signals are sent to the Cooling Motor Driver. If temperature levels move to an unacceptable level the DSP will cause the SL Rx to switch into the Bypass mode. Additionally, the DSP monitors the LNA current. Unacceptable levels of LNA current are sensed via the Power Supply and will cause the SL Rx to switch to Bypass mode. Each time the SL Rx is switched to Bypass mode, the alarm relay is activated.

## Cryogenic Cooling

The STI Stirling Cycle Cryogenic Cooler is a highly efficient state-of-the-art Cryogenic Cooler. The Cryogenic Cooler maintains the CoRE at an operating temperature of ~78 K (Kelvin). The compressor and cold finger are fully integrated into a single self-contained unit. The Cooling Motor Driver provides drive and control to maintain a constant temperature. Temperature sensors in both the CoRE and the STI Stirling Cycle Cryogenic Cooler provide for constant temperature monitoring of the system by the Thermal Sensor Interface.

## Power

27 VDC input power is received at the POWER terminal block connections, located on the rear panel of the SL Rx. DC power is routed through a 10-amp fuse to the fan and the power supply. The fan provides cooling air for SL Rx components installed outside the CoRE. The power supply routes regulated DC power to all SL Rx assemblies.



**Figure 4. Functional Block Diagram**

# Indicators, Connectors, and Controls

## Front View of the SuperLink Rx

The SL Rx provides two indicators, or LEDs, and one control on the front panel as shown in Figure 5 and described in Table 1.

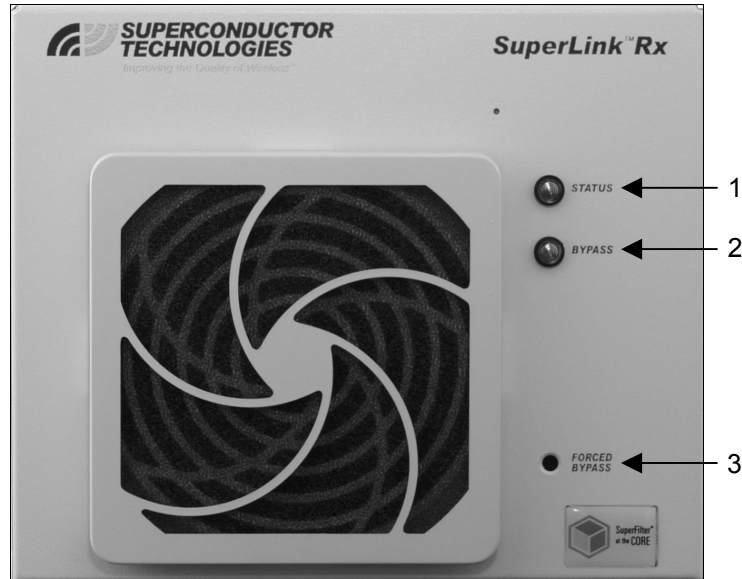


Figure 5. Front Panel Indicators

Table 1. Front Panel Indicators and Controls

Item No.	Item	Description
1	<b>STATUS LED</b>	Illuminates GREEN when the SL Rx is in SuperLink mode (Regulate state).
2	<b>BYPASS LED</b>	Illuminates RED when the SL Rx is in Bypass mode.
3	<b>FORCED BYPASS button</b>	Places the system in Forced Bypass mode when you press this button. The LEDs flash in Forced Bypass mode.



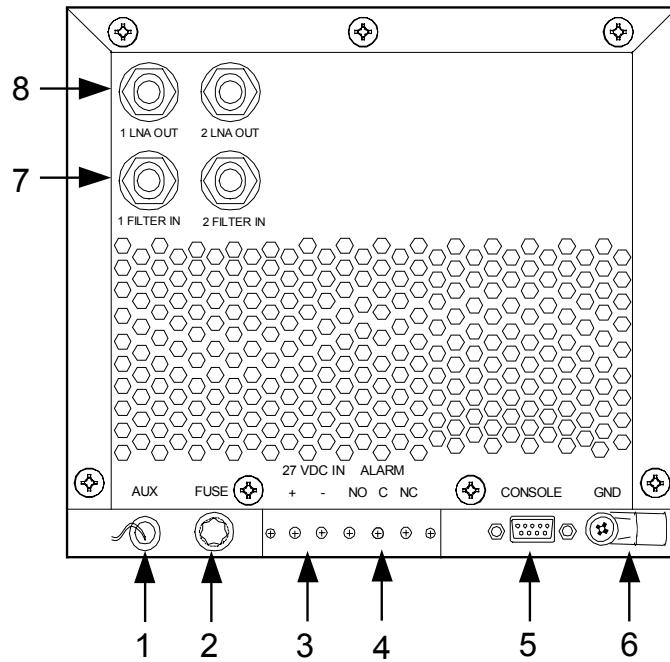
For more information about the LEDs, see Table 7.

## Rear Panel of the SuperLink Rx

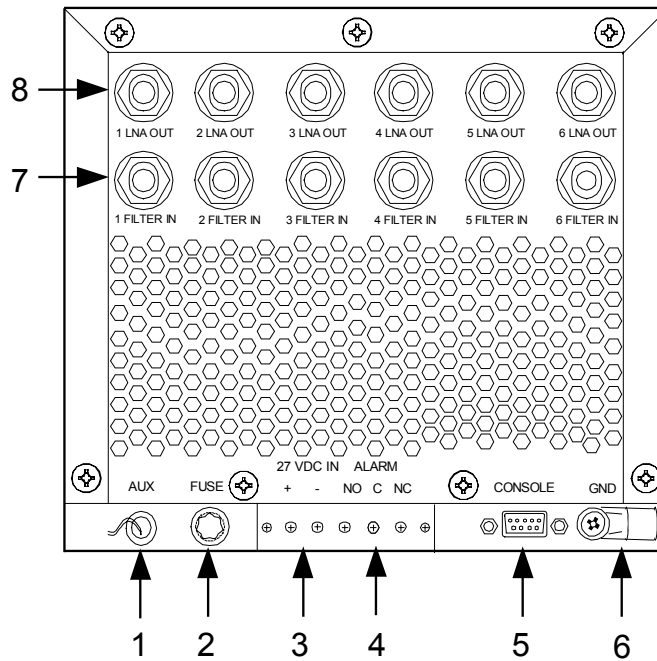
The rear panel contains signal and power connectors. The following figures show the different rear panel views:

- Figure 6 shows a 2-Pak SL Rx system
- Figure 7 shows a 6-Pak SL Rx system
- Figure 8 shows a 2-Pak SL Rx system, Overlay
- Figure 9 shows a 6-Pak SL Rx system, Overlay

Table 2 describes the controls and connectors located on the rear panel.

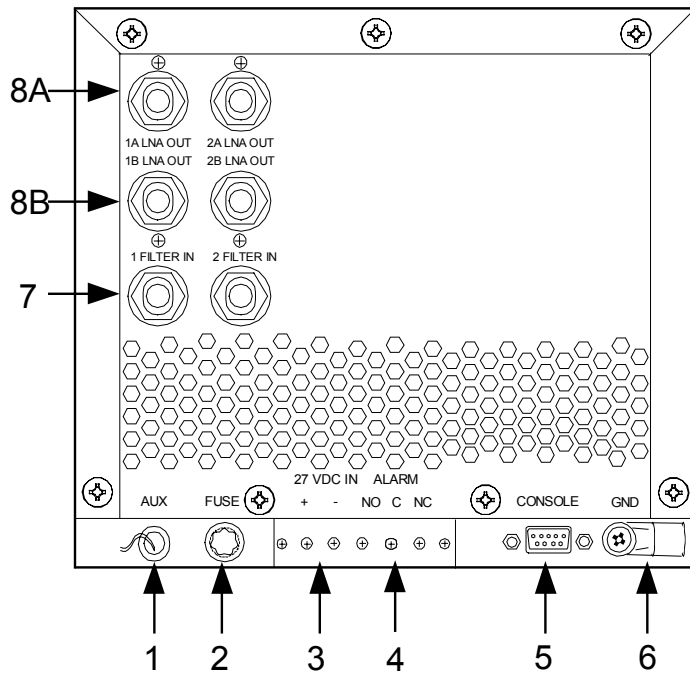


**Figure 6. 2-Pak Rear Panel Connectors and Controls**

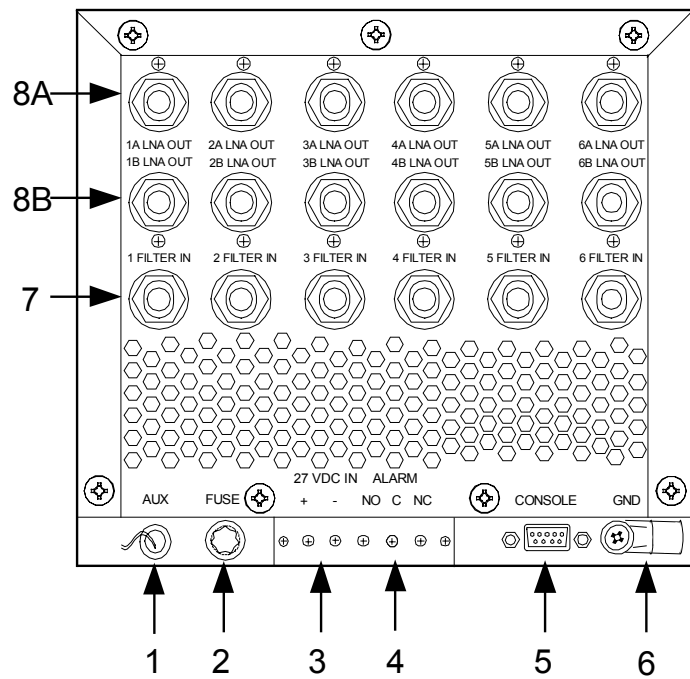


**Figure 7. 6-Pak Rear Panel Connectors and Controls**





**Figure 8. 2-Pak Rear Panel Connectors and Controls, Overlay**



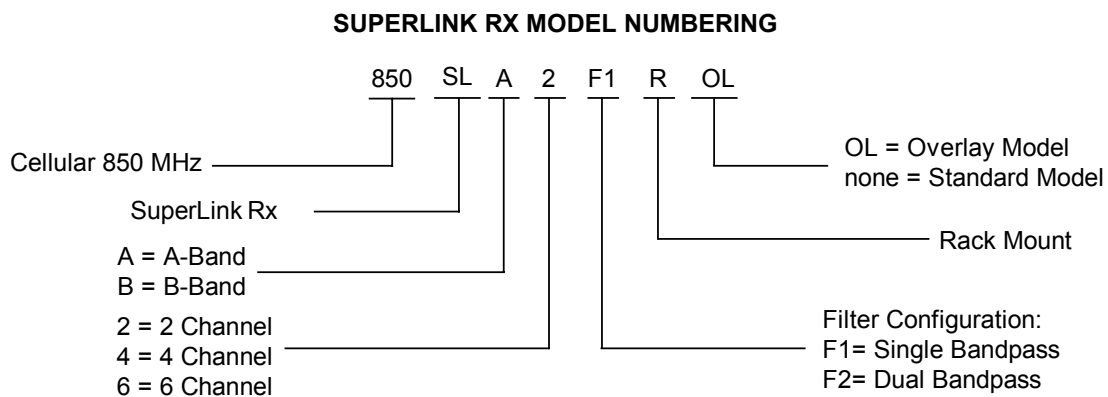
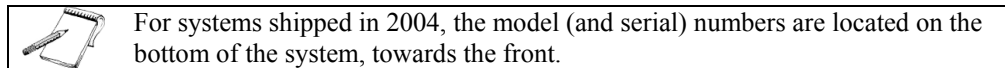
**Figure 9. 6-Pak Rear Panel Connectors and Controls, Overlay**

**Table 2. Rear Panel Connectors and Controls**

Item No.	Item	Description
<b>Power and Control Connectors</b>		
1	<b>AUX</b>	Reserved for future application.
2	<b>FUSE</b>	With a 27 VDC input, provides 10-amp input power protection for the SL Rx.
3	<b>27 VDC IN + and -</b> (Terminal Block)	Provides input power connection for 27 VDC.
4	<b>ALARM NO, C, and NC</b> (Terminal Block)	Provides connection from the alarm relay to the base station alarm system.
5	<b>CONSOLE</b> connector	Provides an RS-232 serial interface connection to the PC. (You can verify that the system is in SuperLink mode (Regulate state) and check the system parameters using a PC.)
6	<b>GND</b>	Chassis ground lug.
<b>RF Connectors</b>		
7	<b>1 FILTER IN</b> RF Connector (SL Rx input)	N-type connector that receives RF signals from the Antenna for each SL Rx receive path.
8A	<b>1A LNA OUT</b> RF Connector (SL Rx output)	N-type connector that routes RF signals from each SL Rx receive path output to the base station front-end input. (Use complete row of A's for one base station.)
8B	<b>1B LNA OUT</b> RF Connector (SL Rx output)	N-type connector that routes RF signals from each SL Rx receive path output to the base station front-end input. (Use complete row of B's for the second base station.)

## Model Number Identification

The SL Rx model number provides information on filter generation, frequency ranges, number of RF receive paths, and types of options selected. The model (and serial) numbers are located on the top cover, towards the back of the system. See Figure 10 for a description of the STI SL Rx model numbers.



**Figure 10. Model Numbering**



---

## Chapter 3 Unpacking the SuperLink Rx

---

### Reviewing the Contents of the SuperLink Rx Package

---

When you unpack the SL Rx package, review the contents to ensure you received the supplied items as shown in Table 3. If you discover any items missing, call the CS-Hotline.

**Table 3. Equipment Supplied**

Item No.	Item	Part Number	Qty	Notes
1	SL Rx, 2-Pak or 6-Pak	As ordered	1 each	2-Pak or 6-Pak SL Rx as ordered.
2A	Rack Mount Brackets, 19-inch Right Side Left Side	180-0605 180-0606	1 pair	As ordered, one pair of either 19-inch or 23-inch rack mount brackets ships with each SL Rx.
2B	Rack Mount Brackets, 23-inch Right Side Left Side	180-0609 180-0606	1 pair	
3	Machine Screws, Round Head, Phillips Head 10/32-inch x 1/2-inch long	360-0098-0500	8 each	Use four Round Head Screws to mount each rack mount bracket to the SL Rx.
4A	Hex head, Type F, #12-24 x .75-inch long	360-0169-0750	4 each	Use four Hex head screws to mount the SL Rx with rack mount brackets to the base station.
4B	Hex head, Type F, #10-32 x .75-inch long	360-0168-0750	4 each	
5	STI CD	831-0001	1 each	Contains the product manual and the STI System Status Portal software that communicates with the SL Rx.

## Unpacking the SuperLink Rx

---

STI uses cutout protective foam packing to prevent damage to the system during shipment. The following steps ensure that you unpack the SL Rx properly.

1. Inspect the shipping container for signs of damage. Report any damage to the CS-Hotline.
2. Remove loose packing materials on top of the SL Rx.
3. Remove the rack mount brackets located between the corner of the shipping container and the foam packing material.
4. Remove the bag containing the attaching hardware for the rack mount brackets. The bag is taped to the top of the SL Rx.
5. Remove the STI CD taped on top of the SL Rx.
6. With foam packing materials in place, lift the SL Rx from the shipping container. Place the SL Rx on a work surface.
7. Remove the foam packing from each end of the SL Rx.
8. Do not remove the plastic ESD covers from the RF connectors at this time. Remove these covers when you are ready for the SL Rx Receive Path Gain test in Chapter 5, "Installing the SuperLink Rx."
9. Inspect the SL Rx for signs of damage. Report any damage to the CS-Hotline.
10. Retain the shipping container and all packing materials for reuse. Store the shipping container in a dry place.

# Instructions for Return Shipment

---

The SL Rx may be returned to STI to incorporate an optional feature, upgrade to a newer model, or for repair. STI handles all upgrades and repair activity. To return a system, complete the following:

1. Call the CS-Hotline for a Return Material Authorization (RMA) number. Provide the following information:

- Model number (located on the rear panel or the bottom front of the SL Rx)
- Serial number (located on the rear panel or the bottom front of the SL Rx)
- Comprehensive description as to the nature of the return



For systems shipped in 2004, the model (and serial) numbers are located on the bottom of the system, towards the front.

The representative will inform you about the return shipment process, including a brief explanation about shipping Hazardous Materials. You must be certified to ship Hazardous Materials.

The representative will mail you a packet that contains the information you need to learn more about Hazardous Materials and to properly ship the system back to STI.

2. The day you receive your paperwork, the representative will contact you to discuss Hazardous Materials. The representative will certify you after a brief discussion over the phone, concluding with a quiz. When you successfully complete the quiz, provide the representative with the following information to complete your certification:

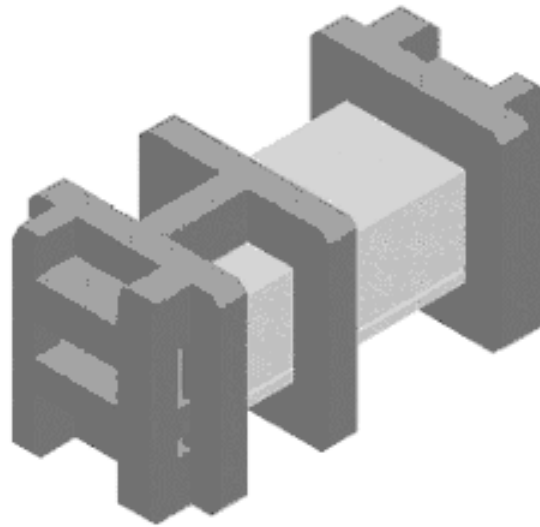
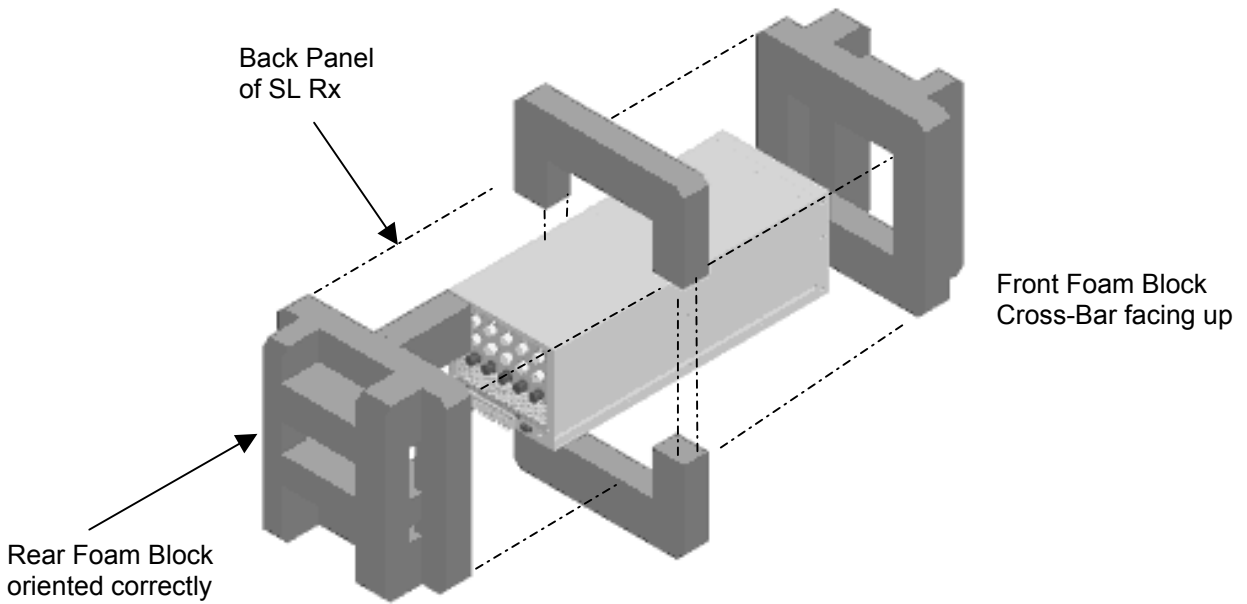
- Your title
- Immediate supervisor's name
- Immediate supervisor's email

3. After you are certified, follow the instructions provided in the RMA packet to ship the system back to STI.



Failure to properly package the SL Rx system could result in significant shipping damage. STI is not responsible for shipping damage due to improper packaging. See Figure 11 for appropriate packing procedures.

Keep the original shipping container for return shipment, or request a new shipping container from STI.



**Figure 11. Foam Packaging Installation**

---

# Chapter 4 Installation Requirements

---

## Overview

---

Before you install the SL Rx, review the installation requirements:

- Establish the site requirements
- Assemble the tools and materials required for installation
- Assemble the functional checks test equipment
- Review the PC requirements for the Java Runtime Environment/System Status Portal



The tools, materials, and test equipment are not supplied with the SL Rx. The following sections guide you in preparing the items you need to install the SL Rx. If you have questions about the installation requirements, call the CS-Hotline.

## SuperLink Rx Requirements

---

### Site Requirements

You are responsible for providing the facilities and environmental controls for the SL Rx installation. Review the following site requirements:

- Sheltered enclosure with temperature and humidity control.
- Conditioned air as required, maintaining the SL Rx between 0°C and 50°C.
- Humidity control as required, maintaining the relative humidity level between 10% and 95% (non-condensing).
- Mounting location with unobstructed air vent space at the front and rear of the SL Rx.
- 27 VDC Power Source (25 to 30 VDC) provided through a Power Distribution Panel Circuit Breaker of 20-amp capability (15 to 30 amps).
- Remote monitoring connection for the SL Rx alarm relay.



## Required Installation Tools and Materials

You are responsible for providing hand tools and materials to install the SL Rx. Review the following requirements:

**Table 4. Hand Tools Required**

Item No.	Item	Notes
1	Screwdriver, 1/8-inch flat blade	For SL Rx terminal block screws.
2	Screwdriver, Phillips #2	For attaching rack mount brackets (Table 3, Item 2A or 2B) to the chassis, and the ground lug to the system.
3	Hex driver, 5/16-inch	For attaching Hex head screws (Table 3, Item 4A or 4B) to mount the SL Rx to the base station equipment rack.
4	Wire Stripper	For power wire installation.
5	Wire Cutter (diagonal cutter)	For power wire installation and wire tie removal.

**Table 5. Materials Required**

Item No.	Item	Qty	Notes
1	RF Jumper Cable, Flexible, Low Loss (1/2-inch). (Suggest FSJ-4 Andrew Cable or equivalent.)	1 per receive path, length as required.	Male N-type connectors on each end. This cable must be long enough to connect between the existing antenna feed coaxial input connector and the rack-mounted SL Rx. (Rerouting the existing feed jumper cable may be sufficient for this cable.)
2	RF Jumper Cable, Flexible, Low Loss (1/2-inch). (Suggest LDF-4 Cable or equivalent.)	1 per receive path, length as required. Double this quantity if using the Overlay model.	Male N-type connectors on each end. This cable must be long enough to connect the rack-mounted SL Rx output to the existing antenna input connector of the base station receiver.
3	Wire, Duplex 10-gauge	Length as required.	Power wire, 12-gauge for lengths up to 20 feet, 10-gauge up to 30 feet (red and black wire preferred for color coding + and - power, respectively). A spade lug is recommended for 10 AWG wire.
4	Wire, Duplex 24-gauge	Length as required.	If desired, for connecting the SL Rx alarm relay output to the base system Alarm Control Unit.
5	Wire, 6-gauge	Length as required.	For connecting the SL Rx chassis ground to the base station ground.
6	Nylon Wire Ties	As required.	Used to dress cables after installation.
7	20-amp Breaker	As required.	Used to install the system and perform functional checks.

## Required Functional Checks Test Equipment

You are responsible for providing test equipment to perform functional checks on the SL Rx. Review the following table for required test equipment:

**Table 6. Test Equipment Required**

Item No.	Test Equipment	Notes
1	Digital Multimeter (DMM) or equivalent	Checks the alarm relay and input power.
2	Personal Computer (PC) with Comm Port	Accesses SL Rx internal states using the serial port. See the "Reviewing PC System Requirements" section for more information.
3	Straight-thru cable, DB-9 Female Connector to DB-9 Male Connector (50 feet maximum)	Connects PC to SL Rx.
4	Signal Generator, Radio Frequency	Generates a continuous wave (CW) carrier at 830 MHz (A-Band) or 840 MHz (B-Band), with output level adjusted to -50 dBm.
5	Spectrum Analyzer	Receives and displays CW carrier at 830 MHz (A-Band) and 840 MHz (B-Band), across levels -55 to -35 dBm; measure received power level accurately ( $\pm 1$ dB).
6	Connector Adapter, N-Female to N-Female (N-type barrel)	Replaces the SL Rx for test signal level calibration.



HP 8921 Test Set, or equivalent, provides both the Signal Generator and the Spectrum Analyzer function.

## Reviewing PC System Requirements

To communicate with the SL Rx, STI provides two programs you need to install on your PC: Java Runtime Environment and the System Status Portal. The Java Runtime Environment is required for the System Status Portal to operate properly. If you already have the Java Runtime Environment on your PC, you do not need to install this program.

Review the system requirements to ensure your PC has the minimum system requirements to run these programs. Call the CS-Hotline if you have questions about the requirements.

- Windows 95, 98 (1<sup>st</sup> or 2<sup>nd</sup> edition), 2000, NT 4.0 (with Service Pack 6), ME, or XP
- Pentium 166 MHz or faster processor
- 70 MB available disk space
- 32 MB RAM minimum, 48 MB RAM (or higher) ideal
- CD-ROM drive
- Comm Port available (supporting 19.2K baud data rates) through a DB-9 connector
- Internet Explorer 5.5 and higher, Netscape Navigator 6.2 and higher, or Netscape Communicator 4.79 and higher



---

# Chapter 5 Installing the SuperLink Rx

---

## Overview

---



Qualified technicians should install the SuperLink Rx system. Contact the CS-Hotline for assistance: 800.727.3648.

Proper installation of the SL Rx consists of the following steps:

- Installing the Java Runtime Environment/System Status Portal
- Mounting the SL Rx
- Connecting the power wire, chassis ground, and alarm relay
- Performing power up/cooldown
- Performing functional checks
- Connecting RF cables

Site-specific installation and checkout information may be available by calling the CS-Hotline.

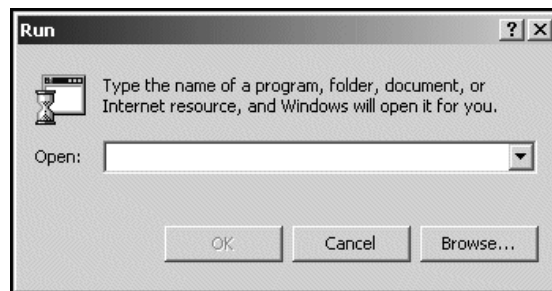
## SuperLink Rx Installation Procedures

---

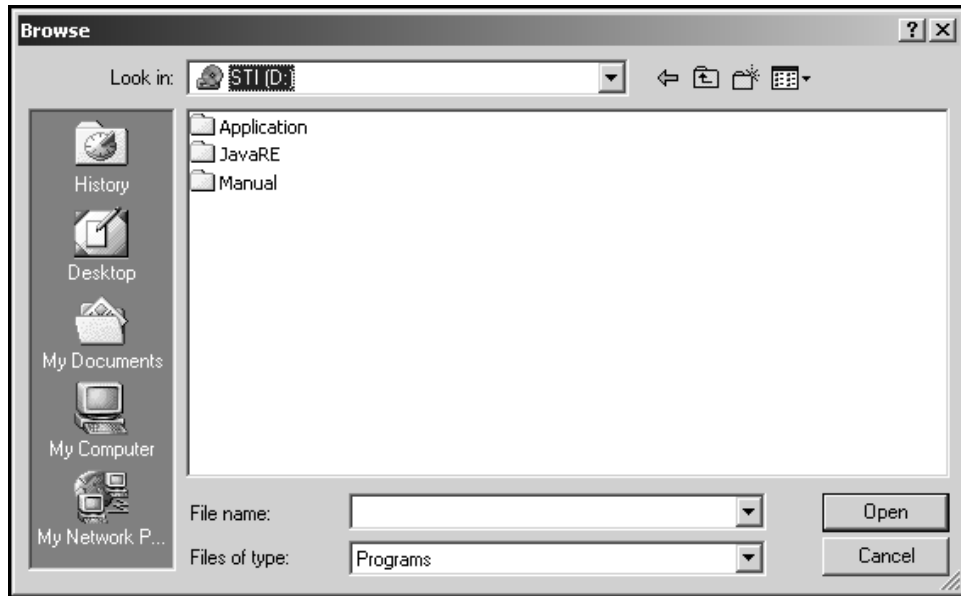
### Installing the Java Runtime Environment

The Java Runtime Environment, version 1.4, supports the System Status Portal. This version is available on the STI CD shipped with the SL Rx. If you currently have this version installed on your PC, you do not need to install this program again. To install from the STI CD:

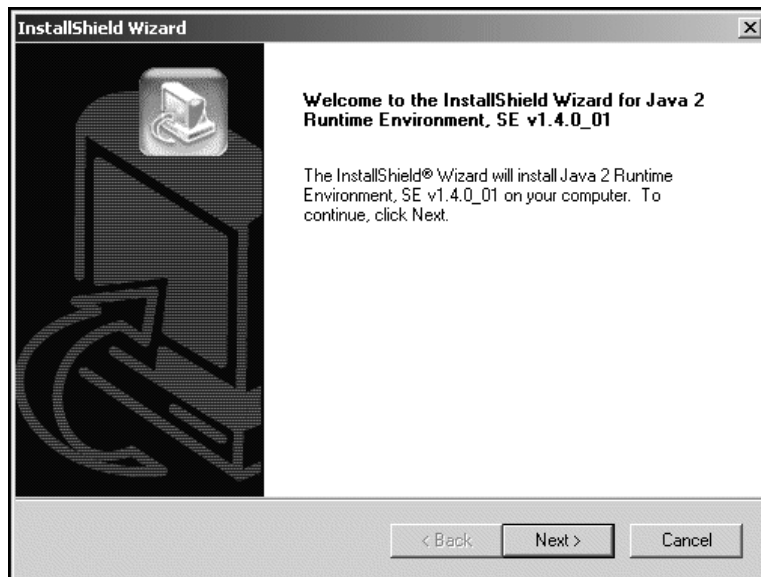
1. Insert the STI CD into your CD-ROM drive.
2. From the **Start** menu, choose **Run...** The **Run** dialog box opens.



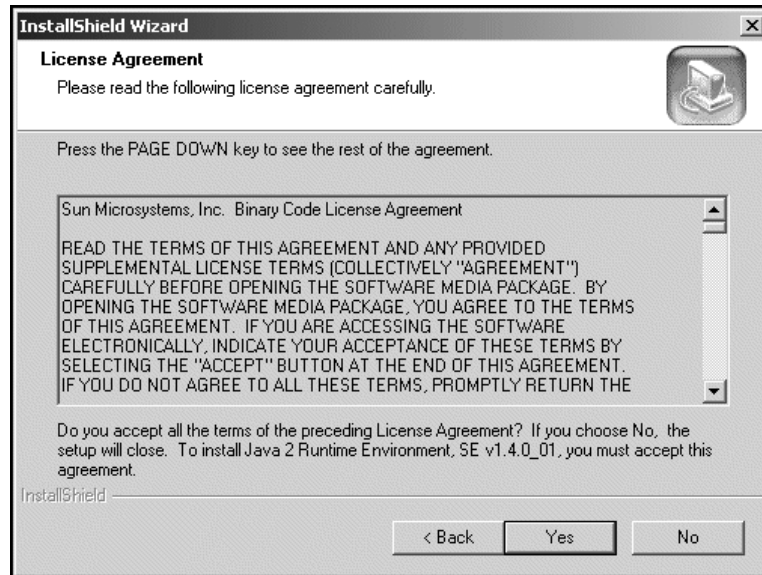
3. To locate the STI CD, click **Browse...** The **Browse** dialog box opens, and defaults to the C: drive. Find the CD-ROM drive on your PC to display the contents of the STI CD.



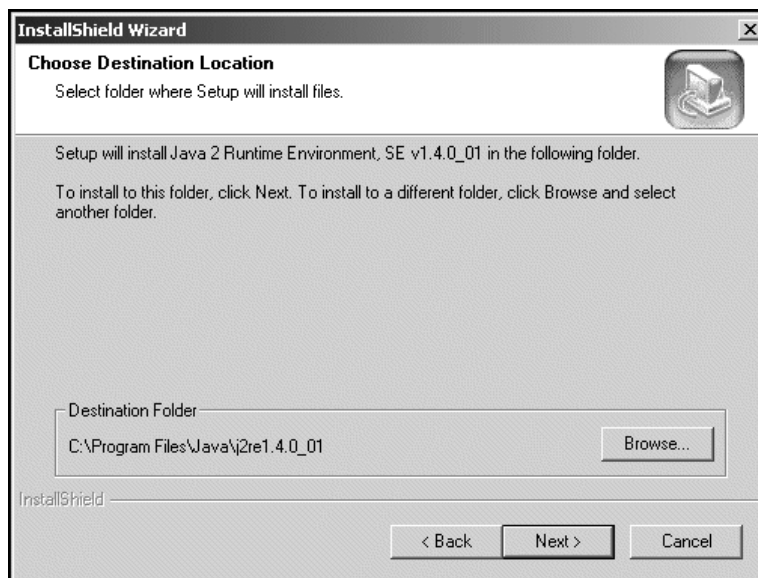
4. Double-click the **JavaRE** folder. This folder contains the setup file for the Java Runtime Environment: **j2re-1\_4\_0\_01-windows-i586.exe**.
5. Double-click the setup file: **j2re-1\_4\_0\_01-windows-i586.exe**. The file path displays in the **Run** dialog box. Click **OK** to begin the installation, and the **InstallShield Wizard** dialog box opens. Click **Next >**.



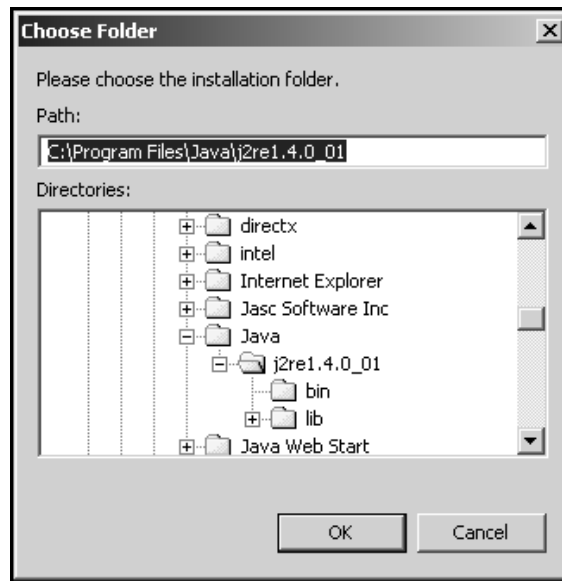
- Review the information on the **License Agreement** dialog box, and click **Yes** to continue with the installation.



- Choose a destination location. By default, the **InstallShield Wizard** chooses the C: drive to install the Java Runtime Environment. Install the program on the default drive: **C:\Program Files\Java\j2re1.4.0\_01**. Click **Next >**.



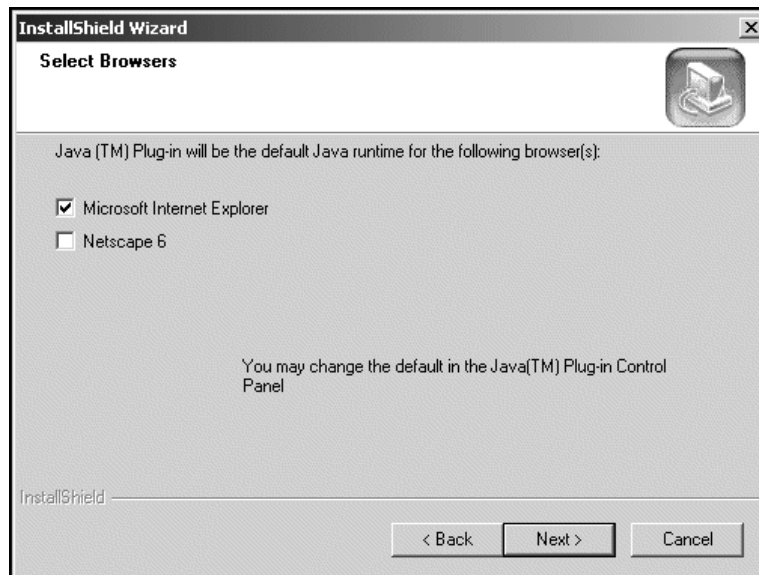
- 7a. If you want to change the destination folder, click **Browse...**. The **Choose Folder** dialog box opens. Choose a folder to install the Java Runtime Environment, and click **OK** to continue with the installation.



8. Choose the browser used on your PC: Microsoft Internet Explorer or Netscape 6. Click **Next >**.



For Netscape users only. Verify that the Java Plugin box is checked to enable proper operation of the System Status Portal. Choose **Edit > Preferences**. Find **Category** and click **Advanced**. In this window, check **Enable Java Plugin**, and click **OK**.

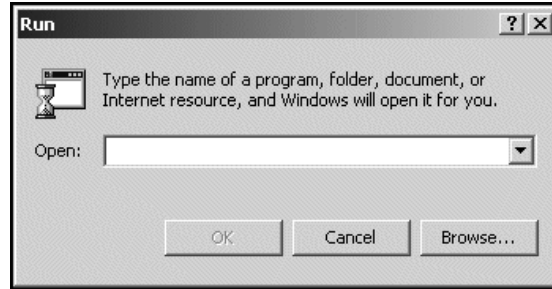


The **InstallShield Wizard** installs the Java Runtime Environment on your PC. When the installation is complete, the Java Runtime Environment InstallShield Wizard closes.

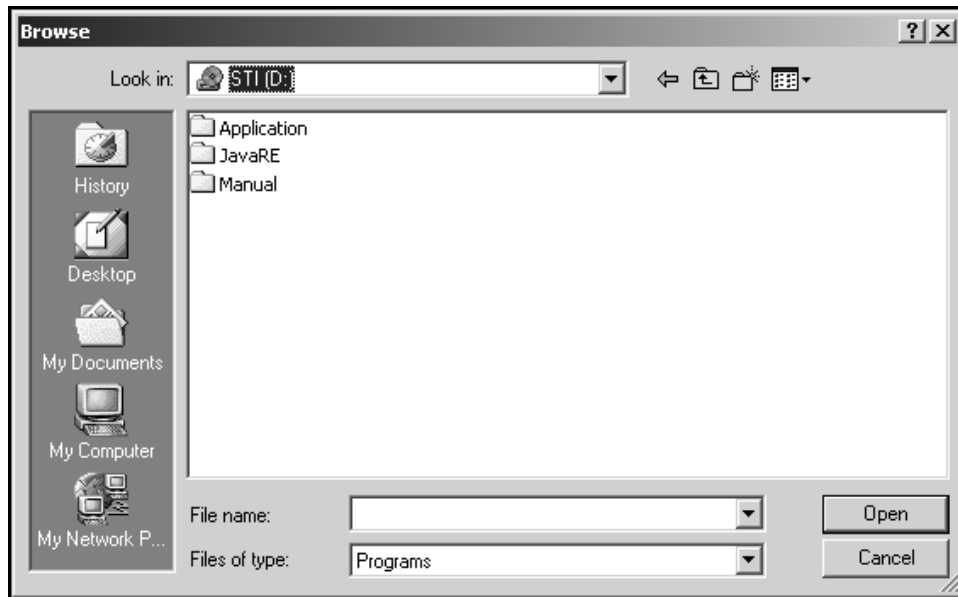
## Installing the System Status Portal

The System Status Portal provides a user-friendly interface to observe the operating parameters of the SL Rx. For more information about using the System Status Portal, see Appendix A, “Using the System Status Portal.”

1. Locate the STI CD using **Start > Run...** The **Run** dialog box opens.



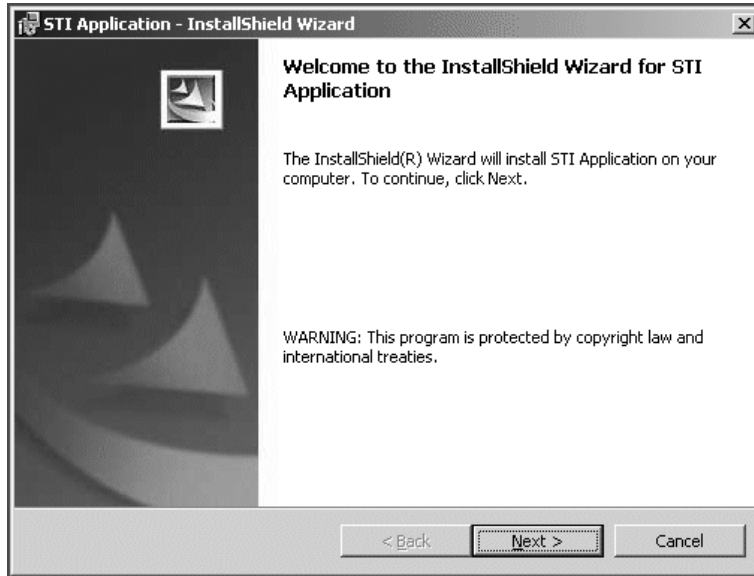
2. To locate the STI CD, click **Browse...** The **Browse** dialog box opens, and defaults to the C: drive. Find the CD-ROM drive on your PC, and display the contents of the STI CD.



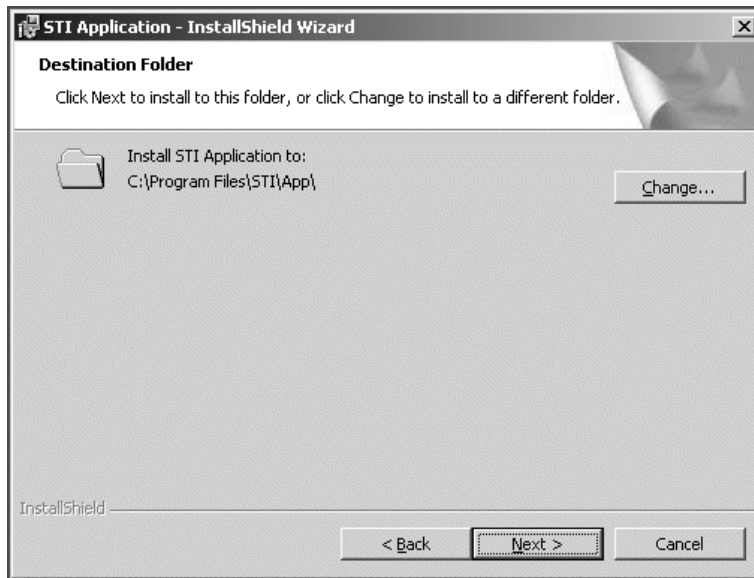
3. Double-click the **Application** folder. The folder contains the setup file for the System Status Portal: **setup.exe**.



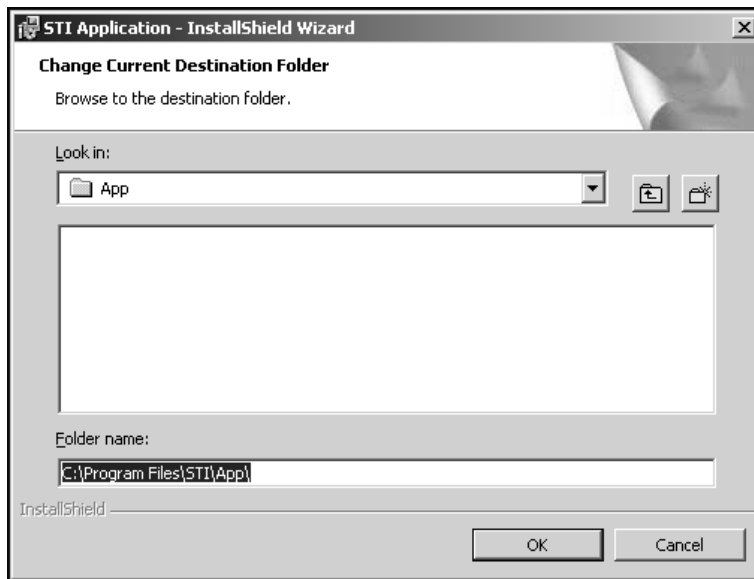
4. Double-click the setup file: **setup.exe**. The file path displays in the **Run** dialog box. Click **OK** to begin the installation, and the **InstallShield Wizard** dialog box opens. Click **Next >**.



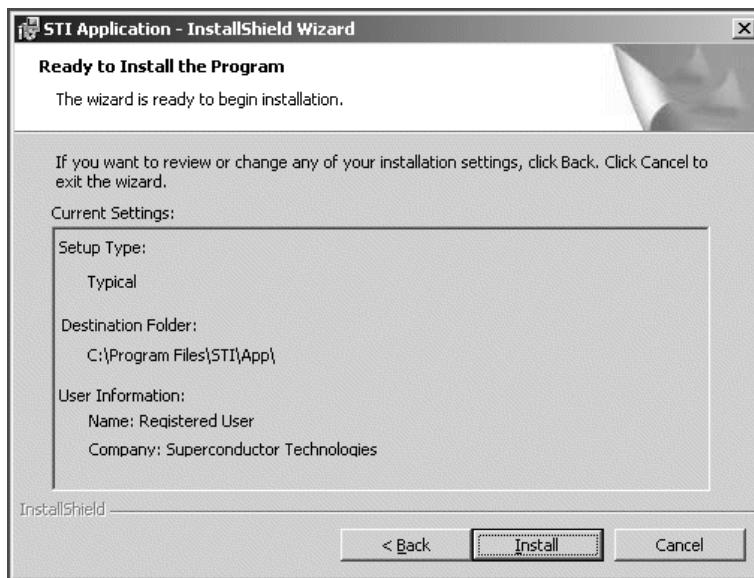
5. Choose a Destination Folder. By default, the **InstallShield Wizard** chooses the C: drive to install the System Status Portal. Install the program on the default drive and folder: **C:\Program Files\STI\App\**. Click **Next >**.



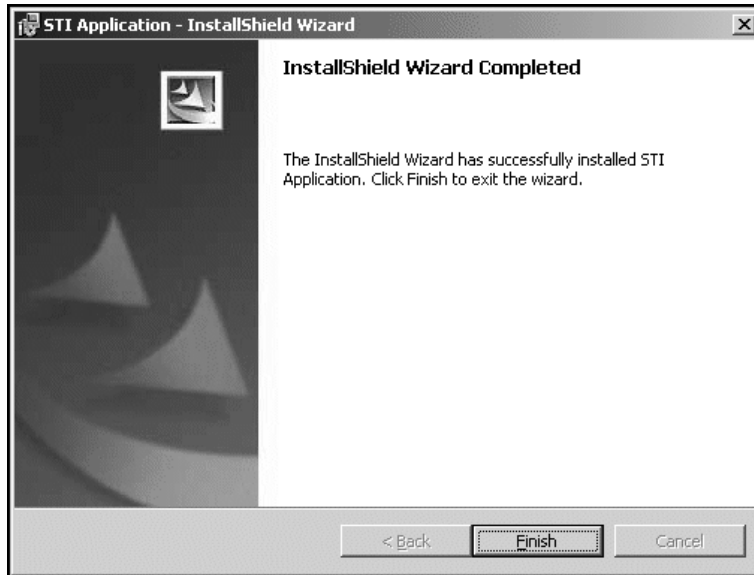
- 5a. If you want to change the destination folder, click **Change...**. The **Change Current Destination Folder** dialog box opens. Choose a folder to install the System Status Portal, and click **OK** to continue with the installation.



6. Review the installation settings before you complete the installation. If you need to make any changes, click **< Back** to review the previous screens. Click **Install** to continue with the installation.



7. When the installation is complete, the **InstallShield Wizard Completed** dialog box displays. Click **Finish**. You are now ready to use the System Status Portal.



## Mounting the SuperLink Rx on the Equipment Rack

The rack mount location of the SL Rx should allow the RF jumper cable attached to the antenna bulkhead to reach the input connector of the SL Rx. If this is not possible, you need to replace the jumper cable with another cable of sufficient length to complete the connection. This cable contributes to the input noise figure, so for optimum performance the cable should be of minimum length, and have a low insertion loss.



The SL Rx contains components that are subject to damage from electrostatic discharge (ESD). Take precautionary measures when handling components mounted on the rear panel of the SL Rx.



Your SL Rx shipment includes the rack mount brackets (Table 3, Item 2A or 2B) you specified at the time of purchase. Use the rack mount brackets to mount the system as shown in Figure 12.

1. Using a Phillips #2 screwdriver (Table 4, Item 2), secure the rack mount brackets (Table 3, Item 2A or 2B) to the SL Rx using four machine screws (Table 3, Item 3) for each bracket. Review the part numbers to ensure that the rack mount brackets are installed on the correct side of the SL Rx.

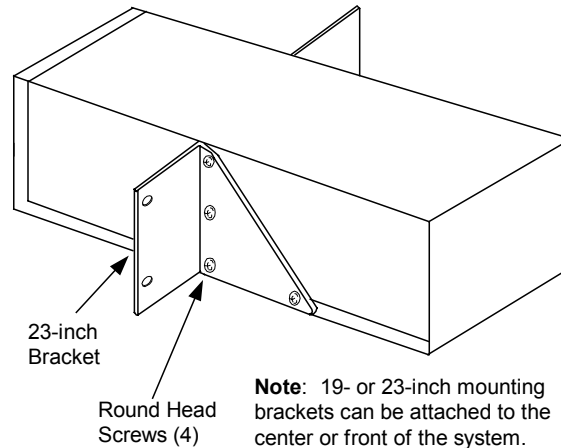


Ensure that the selected mounting location provides an unobstructed air vent space at the front and rear of the SL Rx.

2. Install the SL Rx into the equipment rack. Using a Hex driver (5/16-inch) (Table 4, Item 3), secure the SL Rx to the equipment rack using the Hex head screws (Table 3, Item 4A or 4B) provided.



The SL Rx can be mounted to the cable tray or directly to a wall. For information on price and availability of cable tray or wall mounting kits, call the CS-Hotline.




**Figure 12. Example of SuperLink Rx with 23-inch Rack Mount Brackets, Center-Mounted**


## Connecting the Chassis Ground


Connect the chassis ground to the base station ground using 6-gauge green wire (Table 5, Item 5).

1. Using a Phillips #2 screwdriver (Table 4, Item 2), remove the spade lug.
2. Crimp the lug to the green wire (Table 5, Item 5), and then reattach the lug to the chassis ground.
3. Connect the other end of the green wire to the base station ground halo.

## Connecting the Power Wire

 Do not exceed a 30-amp circuit breaker rating on a 12-gauge wire or a 40-amp circuit breaker rating on a 10-gauge wire. Excess current capacity may result in a fire hazard. Qualified electricians should install the power wire, providing recommendations based on the set up.

 Keep the power wire to less than 30 feet in length. A 10-gauge wire is preferred but a 12-gauge wire may be used for wire lengths of less than 20 feet.

 Before you proceed, set the power source circuit breaker to the open or off position. Failure to comply may result in personnel injury.

1. Select a breaker in the Power Panel. Operate (open) the breaker to turn off power in the circuit.
2. Run the power wire (Table 5, Item 3) from the base station power distribution circuit breaker box to the terminal block on the rear panel of the SL Rx. The terminal block connections are labeled **27 VDC IN +** and **-**. See Figure 6, 7, 8, or 9 for rear panel terminal block connections on the SL Rx.
3. Connect the wires at each end, being careful to maintain the correct voltage polarity. Do not close the circuit breaker at this time.

## Connecting the Alarm Relay

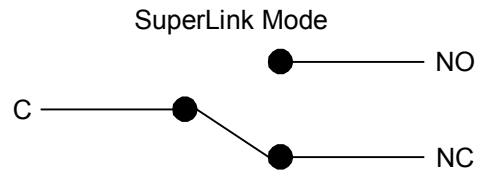
The alarm relay provides a warning alarm that you can monitor remotely. You have the option of connecting the output of the SL Rx alarm relay to the base station alarm control system. See Figure 13 for the states of the alarm relay.

Some base station alarm systems require an open contact while others require a closed circuit. The SL Rx will allow for either choice. Determine which contacts to use by consulting the Base Station Alarm System documentation.

1. Using a screwdriver (1/8-inch) flat blade (Table 4, Item 1), connect a 24-gauge duplex wire (Table 5, Item 4) between the base station alarm panel and the terminal block connections on the SL Rx labeled **C** (Common) and **NC** (Normally Closed) or **NO** (Normally Open), whichever is required by the alarm system.

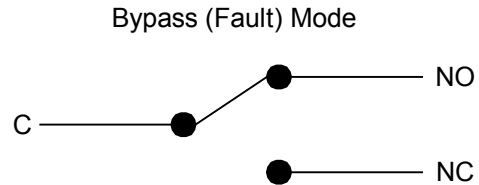
### Alarm Relay Normal Operation Condition

NO = Open in normal operation  
C = Common  
NC = Closed in normal operation



### Alarm Relay Fault Condition (Failure)

NO = Closed during fault condition  
C = Common  
NC = Open during fault condition



**Note:** Alarm Relay, dry contacts, rated at 2-amps.

**Figure 13. Alarm Relay in Normal and Alarm States**

## Performing Power Up/Cooldown



Before you proceed, set the power source circuit breaker to the open or off position. Failure to comply may result in personnel injury.

1. Ensure the power source circuit breaker (Table 5, Item 7) is set to the open or off position.
2. Remove the fuse from the fuse holder located on the rear panel of the SL Rx.
3. Set the power source circuit breaker to the closed or on position.
4. Verify that the SL Rx input voltage at the terminal block contact reads  $27 \pm 2$  VDC on the DMM. Verify correct polarity.
5. Reinstall the fuse in the fuse holder.
6. Apply power to the SL Rx by setting the power source circuit breaker to the closed or on position.



Initially, both LEDs on the front panel of the SL Rx remain on and steady during cooldown.

When the SL Rx cryogenic chamber has reached operating temperature ( $\sim 78$  K), the **STATUS** LED will be steady GREEN and the **BYPASS** LED will be off.

7. The SL Rx will automatically switch from Bypass mode to SuperLink mode (Regulate state) when cooled. If the system fails to go into SuperLink mode (Regulate state) within 5 hours, call the CS-Hotline.



When the SL Rx reaches SuperLink mode (Regulate state) the **STATUS** LED will be GREEN. When the system is in Bypass mode, the RF path relays operate to exclude the High Temperature Superconductor (HTS) filter and LNA from the receive path, indicated by a steady RED LED. When the system switches to SuperLink mode (Regulate state), the **STATUS** LED changes to solid GREEN.

Table 7 provides the following states, relay settings, and indicator readings for the SL Rx.

**Table 7. SuperLink Rx Internal States and Status**

Mode	State Name	Bypass Relay State	Indicators		Description
			BYPASS (RED)	STATUS (GREEN)	
Bypass	0. Initial	Bypass	On	On	Initializes the system and powers up the cooler motor to minimum power setting. Transitions to the Cooldown state.
Bypass	1. Cooldown	Bypass	On	On	Cools down the CoRE. The Cooldown state runs the cooler motor at the maximum motor drive power, based on the cooldown profile of the cooler. The LNAs turn on in the Cooldown state when the cold stage narrow range temperature is within operating bounds. Transitions to Regulate state when the narrow range temperature is within its operating tolerance for 300 seconds (LNA on).
SuperLink	2. Regulate	Normal	Off	On	Regulates the cold stage temperature indefinitely.
Bypass	3. Bypass (Fault)	Bypass	On	Off	Continues to regulate the cooler temperature. This Fault state occurs when the Input Voltage is out of bounds. When the Input Voltage fault has cleared, the system transitions back to the Regulate state (Automatic mode).
Bypass	4. Shutdown (Fault)	Bypass	On	Off	The cooler motor drive reduces to zero and is turned off. Transitions back to Initial state in Automatic mode when cold stage narrow range temperature has warmed sufficiently to be out of its valid range and the faults are cleared.
Bypass	5. Forced Bypass	Bypass	Flash if On	Flash if On	Forces the system into Bypass mode regardless of any other conditions. At least one LED should always flash on if in Forced Bypass mode.

→ Regulate state = SuperLink mode. In all other states, the SL Rx is in Bypass mode.

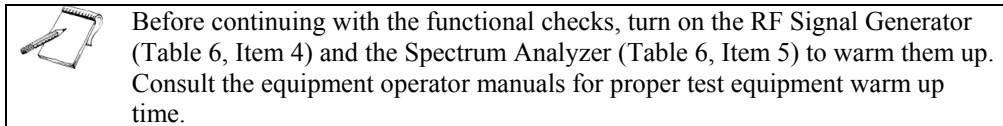
## Performing Functional Checks

Before you can perform any functional checks for the SL Rx, the system must be in SuperLink mode (Regulate state). If the system is not in SuperLink mode (Regulate state) after five hours, review Chapter 6, “Troubleshooting Tips.” When your system is in SuperLink mode (Regulate state), continue with the functional checks.

The functional checks consists of the following procedures:

- Console connection and operation
- Alarm relay test
- Test generator calibration data
- SL Rx receive path gain test

Review the test equipment required for these functional checks in Table 6.



### Console Connection and Operation

Check the operational parameters of the SL Rx.

1. Connect the DB-9 cable (Table 6, Item 3) to your PC (Table 6, Item 2) and the SL Rx as shown in Figure 14.

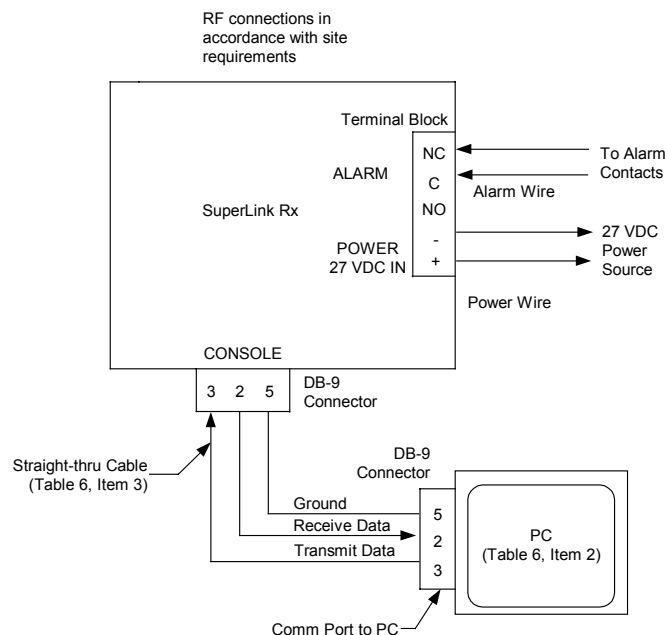
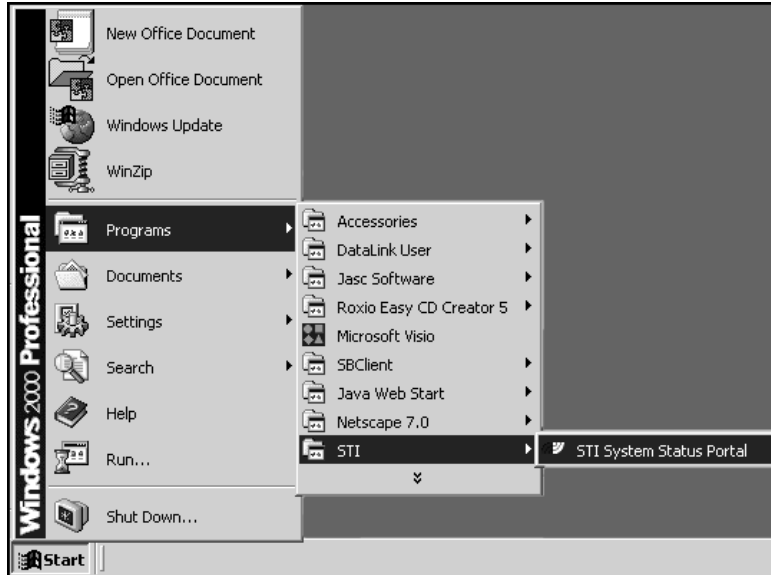


Figure 14. PC Connection to the SuperLink Rx



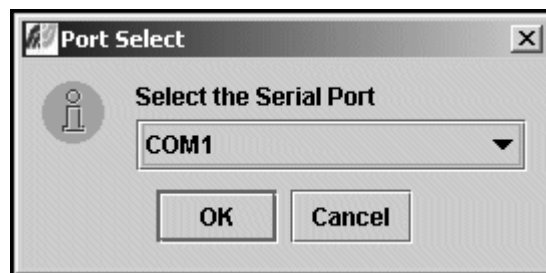
- From the **Start** menu, choose **Programs > STI > STI System Status Portal**.



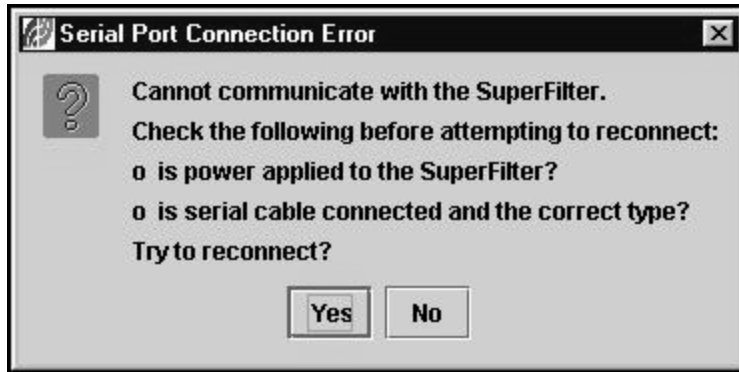
The System Status Portal opens.



- Click **Communicate with Unit** to establish communication with the SL Rx.
- Select the correct Comm Port to establish communication, and then click **OK**. Typically, the System Status Portal selects COM1 as the available Comm Port.




- 4a. If a connection cannot be established after five seconds, the **Serial Port Connection Error** dialog box displays.



- 4b. Review the message in the dialog box, and try reconnecting again. If the problem persists, call the CS-Hotline.


 See Chapter 6, “Troubleshooting Tips” if you cannot establish communication with your system, or call the CS-Hotline.

 Before you check the Wide Range Cold Finger Temperature, the system must be in SuperLink mode (Regulate state), indicated by a steady GREEN light on the **STATUS LED**, or cools within 5 hours. If the system fails to go into SuperLink mode (Regulate state) within 5 hours, call the CS-Hotline.

5. Read the Wide Range Cold Finger Temperature (**View > Status > Measure**) and verify that the temperature falls in the range of  $79 \pm 4$  K. If the temperature is out of range, call the CS-Hotline.

### **Alarm Relay Test**

Check the operation of the alarm relay.

 To check the alarm relay parameters of the SL Rx, the system must be in SuperLink mode (Regulate state) before proceeding.

### **Testing the Connection**

1. Push the **FORCED BYPASS** button (Figure 5) on the front panel of the SL Rx. The **STATUS LED** will slow flash GREEN. The alarm relay is now placed in an alarm condition. Verify that the base station alarm is activated.
2. Push the **FORCED BYPASS** button (Figure 5) again. The system will return to SuperLink mode (Regulate state), indicated by a steady GREEN **STATUS LED**. The alarm relay is now placed in normal condition. Verify that the base station alarm system is no longer activated.

## Testing the Alarm Relay

3. Push the **FORCED BYPASS** button (Figure 5) on the front panel of the SL Rx.



The **STATUS** LED will slow flash GREEN; the alarm relay is now in alarm condition.

4. Set the DMM (Table 6, Item 1) to measure resistance.
5. Place the DMM leads between the SL Rx terminal block connections labeled **ALARM C** and **NO**. The DMM should read less than 10 ohms.
6. Move the DMM leads between terminal block connections labeled **ALARM C** and **NC**. The DMM should read greater than 10,000 ohms.
7. After you record the measurements, push the **FORCED BYPASS** button again. The system will no longer be in the Forced Bypass mode.



Ensure you have turned the Forced Bypass off. Otherwise, the SL Rx will remain in Bypass mode, as indicated by the **STATUS** LED continuously flashing GREEN.



The SL Rx **STATUS** LED will be steady GREEN, indicating the system is in SuperLink mode (Regulate state), with the alarm relay in normal position.

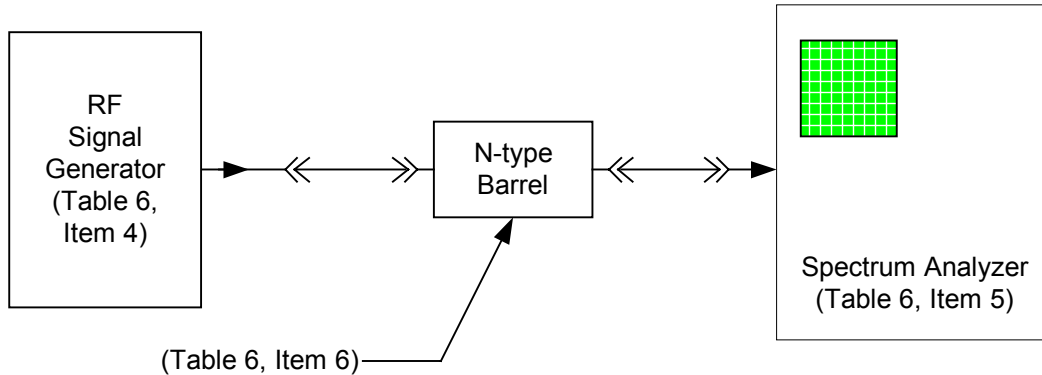
8. Place the DMM leads between the SL Rx terminal block connections labeled **ALARM C** and **NO**. The DMM should read greater than 10,000 ohms.
9. Move the DMM leads between the SL Rx terminal block connections labeled **ALARM C** and **NC**. The DMM should read less than 10 ohms.

## Test Generator Calibration Data

A signal power measurement is the reference level for verifying the SL Rx RF path gain and loss values. Set up the SL Rx test RF reference levels.

1. Turn on the RF Signal Generator (Table 6, Item 4) and the Spectrum Analyzer (Table 6, Item 5) and allow them to warm up. Consult the equipment operator manuals for proper test equipment warm up time.
2. Set the RF Signal Generator to output a CW signal to the following:
  - For SL Rx A-Band:
    - 830 $\pm$ 3 MHz
    - Power level set to -50 $\pm$ 1 dBm
  - For SL Rx B-Band:
    - 840 $\pm$ 3 MHz
    - Power level set to -50 $\pm$ 1 dBm
3. Connect the RF Signal Generator output to the Spectrum Analyzer as shown in Figure 15, substituting an N-type barrel connector adapter (Table 6, Item 6) for the SL Rx.


4. Measure the signal frequency and power level, and make a note of both values in Appendix C, “Receive Path Gain/Loss Calculator.” This signal power measurement is used as the reference level for finding the SL Rx RF path gain and loss values.
5. Remove the N-type barrel connector adapter (Table 6, Item 6).




**Figure 15. Test Generator Calibration Reference Level Measurement Diagram**

### **SL Rx Receive Path Gain Test**

Calculate the RF path loss (Bypass) and gain (SuperLink) levels for the SL Rx preamplifier receive paths. Record the measurements in Appendix C, “Receive Path Gain/Loss Calculator,” or use the Microsoft<sup>®</sup> Excel file labeled **Appendix C** in the **SuperLink Rx Operation and Installation Manual** folder on the STI CD.

 The SL Rx contains components that are subject to damage from electrostatic discharge (ESD). Take precautionary measures when handling components mounted on the rear panel of the SL Rx.

 During these procedures, refer to the SL Rx test setup diagram in Figure 16.

1. Remove the plastic ESD covers from the RF connectors to perform the RF test. Store the covers in the shipping container.
2. To check the RF gain and loss on SL Rx receive path number 1, connect the RF Signal Generator (Table 6, Item 4) to the SL Rx N-type connector labeled **1 FILTER IN**.
3. Connect the Spectrum Analyzer (Table 6, Item 5) to the SL Rx N-type connector labeled **1 LNA OUT**.
4. Push the **FORCED BYPASS** button (Figure 5) on the front panel of the SL Rx.
5. Measure the Bypass loss of the RF output level for receive path 1 and record in Appendix C, “Receive Path Gain/Loss Calculator.”

6. Measure the Regulate gain of the RF output level for receive path 1 and record in Appendix C, “Receive Path Gain/Loss Calculator.”
7. Repeat steps 2-6 to check the RF gain and bypass loss on all additional SL Rx receive paths based on your configuration. You must check each channel one at a time.
8. Calculate the RF path loss (Bypass) and gain (SuperLink) by subtracting the reference level recorded as a result of the Test Generator Calibration Data procedure. (See Appendix C, “Receive Path Gain/Loss Calculator.”)
  - Gain:  $13 \pm 2$  dB
  - Loss:  $-1 \pm 1$  dB



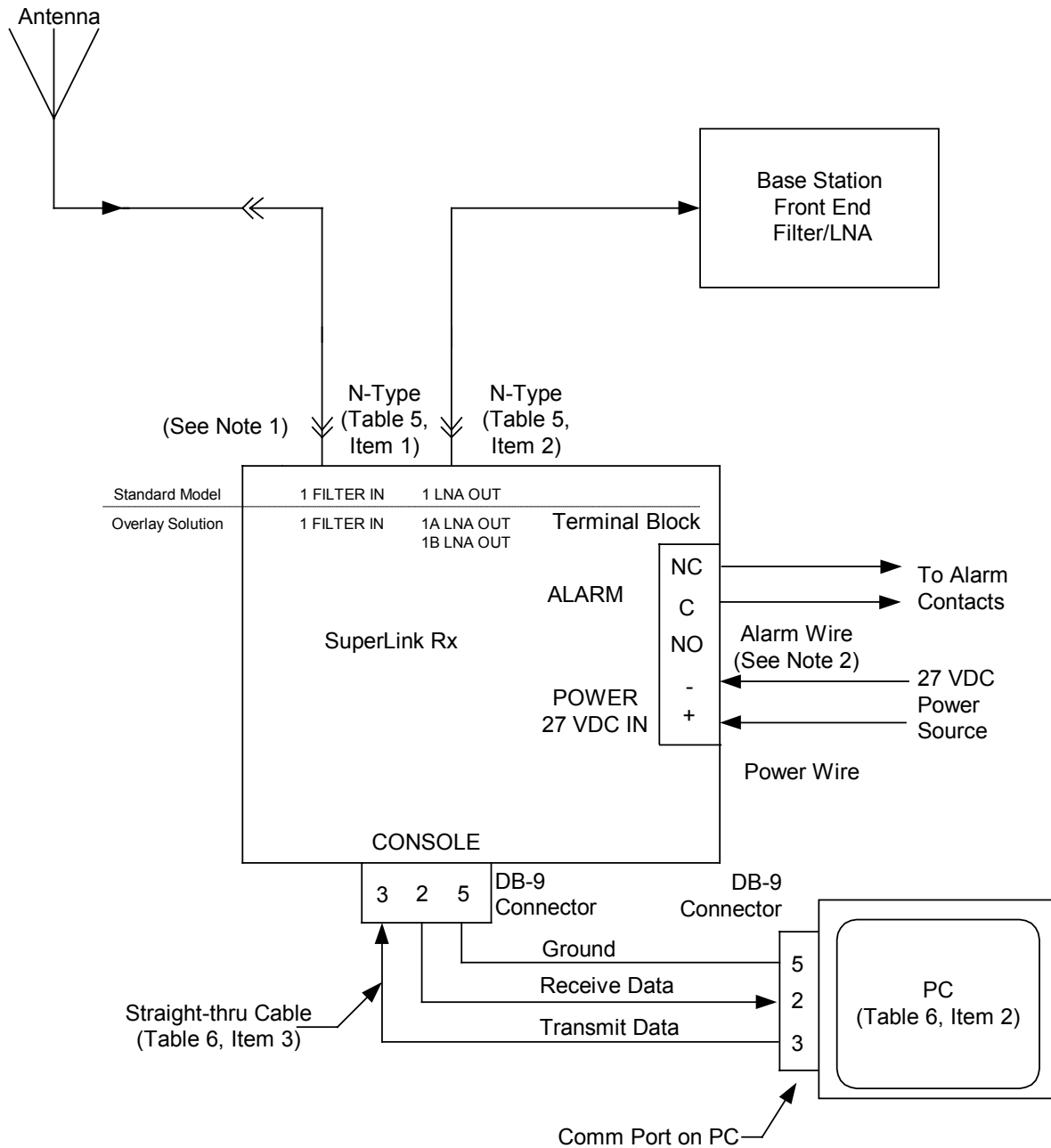
Make sure that the system is in SuperLink mode (Regulate state), indicated by a steady GREEN LED.



For the Overlay model, use the following figures to determine the RF gain and bypass loss:

- Gain:  $9 \pm 2$  dB
- Loss:  $4 \pm 1$  dB

9. Disconnect the RF Signal Generator (Table 6, Item 4) and the Spectrum Analyzer (Table 6, Item 5) and secure them. Leave the PC connected to the SL Rx at this time.



**NOTES:**

1. Receive Path 1 RF Connections shown. RF connections for all additional receive paths are the same.
2. Connect alarm wire in accordance with user-specified Alarm requirements.

**Figure 16. Gain Test Setup**

## Connecting RF Cables

This portion of the procedure connects the SL Rx into the RF receive paths of the base station. The required cables are listed in Table 5, and the connections are shown in Figure 17.



The SL Rx contains components that are subject to damage from electrostatic discharge (ESD). Take precautionary measures when handling components mounted on the rear panel of the SL Rx.



For base station equipment that incorporates a duplexer, ensure that cable connections made between the duplexer and the SL Rx are from the receive side of the duplexer only. Connecting cables from the duplexer transmit port to the SL Rx will cause damage to the SL Rx.

1. In the first receive path, disconnect the existing antenna input jumper cable from the base station front-end. Connect that cable to the SL Rx N-type connector labeled **1 FILTER IN**. If the antenna cable does not reach the SL Rx input connector, replace it with a jumper cable (Table 5, Item 1) of sufficient length.
2. Using the RF jumper cable (Table 5, Item 2), connect the SL Rx connector labeled **1 LNA OUT** to the base station front-end. At this point the RF path from the antenna through the SL Rx and into the base station receiver should be complete and carrying traffic.



Work with only one receive path at a time. Completely reconnect and verify operation of one receive path before moving to another receive path. If both receive paths in a sector are disconnected, all service will be lost in that sector.

3. Verify that signal traffic is evident in the Spectrum Analyzer display by connecting to an open RF port in the power divider or sampling at the input to the base station front-end. If no traffic is observed, review the “Installation Troubleshooting” section in Chapter 6, “Troubleshooting Tips.”



Please connect adjacent channels as Main/Diversity pairs as follows:

1 & 2

3 & 4

5 & 6

4. Repeat steps 1-3 for the remaining receive paths.
5. At the conclusion of the RF cable connections to the SL Rx, dress cables using nylon wire ties (Table 5, Item 6) as required.



The SL Rx has no alarm associated with an RF open/short failure. If the RF performance of one or more channels has degraded, then the corresponding SL Rx channel(s) should be measured. See the SL Rx Receive Path Gain Test on page 39 for more information.

## Connecting RF Cables (Overlay)

This portion of the procedure connects the SL Rx with Overlay model into the RF receive paths of both base stations. The required cables are listed in Table 5, and the connections are shown in Figure 17. For duplexed antennas (combined transmitter and receiver on one antenna), see specific application notes for your base station.



The SL Rx contains components that are subject to damage from electrostatic discharge (ESD). Take precautionary measures when handling components mounted on the rear panel of the SL Rx.



For base station equipment that incorporates a duplexer, ensure that cable connections made between the duplexer and the SL Rx are from the receive side of the duplexer only. Connecting cables from the duplexer transmit port to the SL Rx will cause damage to the SL Rx.

1. In the first receive path, disconnect the existing antenna input jumper cable from the base station front-end. Connect that cable to the SL Rx N-type connector labeled **1 FILTER IN**. If the antenna cable does not reach the SL Rx input connector, replace it with a jumper cable (Table 5, Item 1) of sufficient length.
2. Using the RF jumper cable (Table 5, Item 2), connect the SL Rx connector labeled **1B LNA OUT** to the original base station front-end. At this point the RF path from the antenna through the SL Rx and into the base station receiver should be complete and carrying traffic.



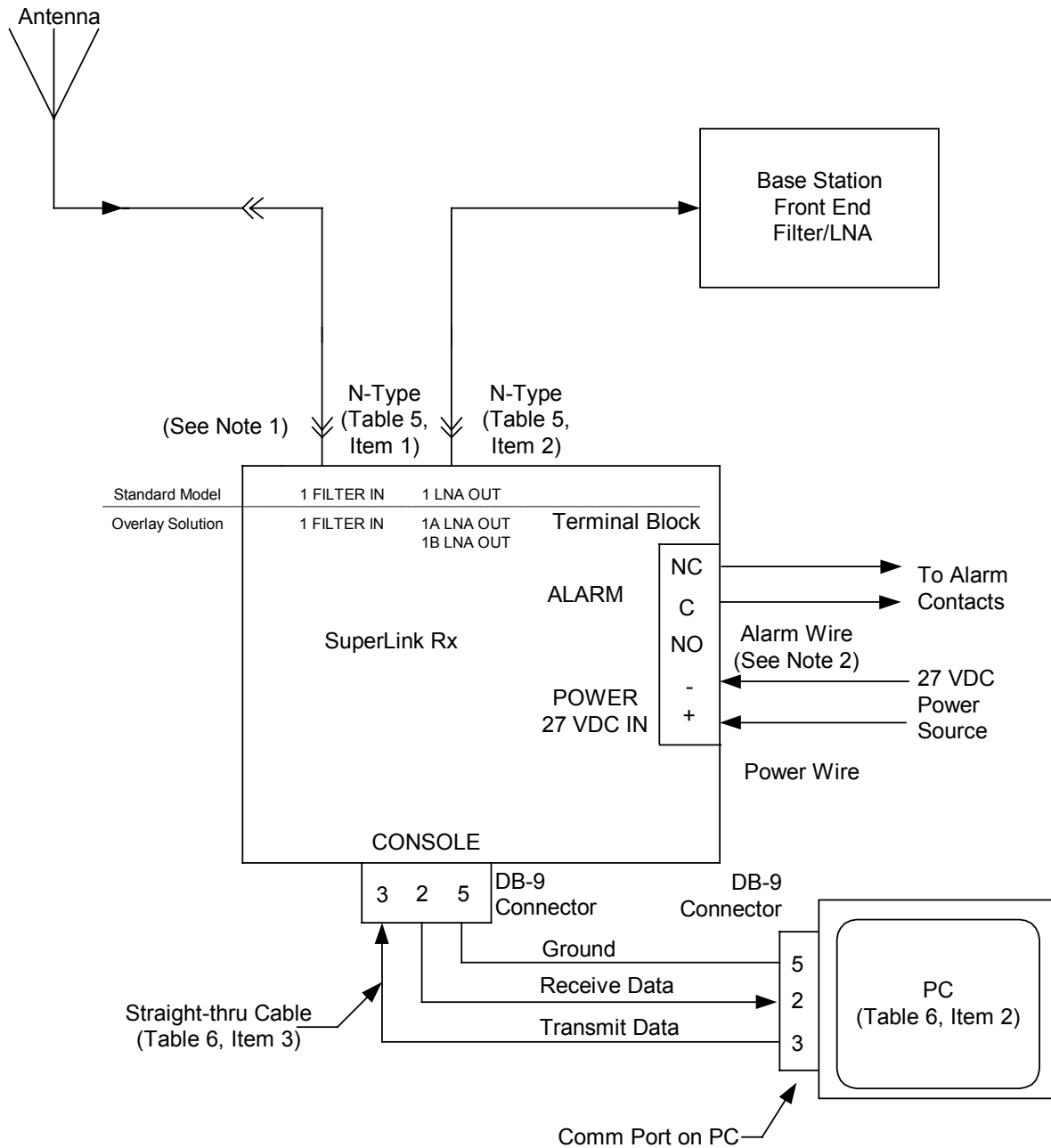
Work with only one receive path at a time. Completely reconnect and verify operation of one receive path before moving to another receive path. If both receive paths in a sector are disconnected, all service will be lost in that sector.

3. Verify that signal traffic is evident in the Spectrum Analyzer display by connecting to an open RF port in the base station's receiver assembly power divider or sampling at the input to the base station front-end. If no traffic is observed, review the "Installation Troubleshooting" section in Chapter 6 "Troubleshooting Tips."
4. Repeat steps 1-3 for the remaining receive paths for the original base station, using the "B" LNA.
5. Repeat steps 2-4 for the "A" LNA outputs, this time connecting to the added base station.
6. At the conclusion of the RF cable connections to the SL Rx, dress cables using nylon wire ties (Table 5, Item 6) as required.



The SL Rx has no alarm associated with an RF open/short failure. If the RF performance of one or more channels has degraded, then the corresponding SL Rx channel(s) should be measured. See the SL Rx Receive Path Gain Test on page 39 for more information.





**NOTES:**

1. Receive Path 1 RF Connections shown. RF connections for all additional receive paths are the same.
2. Connect alarm wire in accordance with user-specified Alarm requirements.

**Figure 17. Cabling Diagram, Cascade and Overlay**

---

# Chapter 6 Troubleshooting Tips

---

## Overview

---

Problems may occur during installation, or from hardware or software failures that occur during operation. This chapter identifies the most common problems, providing troubleshooting tips to resolve them.

If your problem does not appear in this chapter, please call the CS-Hotline for assistance.

<b>Problem No.</b>	<b>Description</b>	<b>Page No.</b>
1	System Status Portal will not install.	Page 46
2	System Status Portal does not run.	Page 46
3	Cannot establish communication with SL Rx.	Page 47
4	No traffic in SuperLink mode (Regulate state). A traffic signal does not appear on the Spectrum Analyzer (detected at the switch or directly in the receive path after the SL Rx).	Page 47
5	LED flashes RED and/or GREEN.	Page 48
6	Fuse blows out or circuit breaker trips.	Page 48
7	The SL Rx does not reach SuperLink mode (Regulate state) after five hours.	Page 49
8	Alarm Relay Test failed.	Page 50
9	Receive Path Gain Test failed.	Page 50
10	In SuperLink mode (Regulate state), the alarm signals when the RF cable is connected between the SL Rx output and receive input.	Page 51
11	<b>BYPASS</b> LED is RED (Alarm is on).	Page 51
12	RF Performance is not optimal, detected by the following conditions: degradation in statistical performance, customer complaints, or Base Station Built-in Test (BIT) failure.	Page 52
13	Abnormal SL Rx noise.	Page 52

## Installation Troubleshooting

---

<b>Problem 1</b>	<b>System Status Portal will not install.</b>
------------------	---

**Cause 1.1** Your PC's operating system (OS) is not compatible with the System Status Portal.

**Solution 1.1** See the "Reviewing PC System Requirements" section on page 21 to see what OS is compatible with the System Status Portal.

**Cause 1.2** Other.

**Solution 1.2** Call the CS-Hotline.

<b>Problem 2</b>	<b>System Status Portal does not run.</b>
------------------	---

**Cause 2.1** Java Runtime Environment may not be installed correctly.

**Solution 2.1a** Check if the Java Runtime Environment is installed (**Start > Programs > Java 2 Runtime Environment**). If the program is not available, install the program from the STI CD, and run the System Status Portal again.

**Solution 2.1b** Check if you have the correct version (1.4) of the Java Runtime Environment installed. If the correct version is not available, uninstall the version on your PC, and install the version of the program from the STI CD.

**Cause 2.2** The System Status Portal installation failed.

**Solution 2.2** If the installation of the System Status Portal failed, reinstall the program again. If it fails a second time, call the CS-Hotline to obtain a new STI CD.

**Cause 2.3** Other.

**Solution 2.3** Call the CS-Hotline.

**Problem 3      Cannot establish communication with SL Rx.**

**Cause 3.1**      Faulty straight-thru cable.

**Solution 3.1**    Use a DMM to check the continuity of the cable. Pin-to-pin connections are shown in Figure 16.

**Cause 3.2**      Straight-thru cable is not seated properly.

**Solution 3.2**    Reseat the cable and try again.

**Cause 3.3**      Unavailable Comm (serial) Port.

**Solution 3.3**    If you run the System Status Portal and the cables are connected to the SL Rx, but you cannot establish communication with the system, an error dialog box opens with a serial communications message. Change the Comm Port, and connect to the SL Rx again. If the problem persists, call the CS-Hotline.

**Cause 3.4**      Other.

**Solution 3.4**    Call the CS-Hotline.

**Problem 4      No traffic in SuperLink mode (Regulate state). A traffic signal does not appear on the Spectrum Analyzer (detected at the switch or directly in the receive path after the SL Rx).**

**Cause 4.1**      RF cable connections are not correct.

**Solution 4.1**    Check the cables for proper connection (see Figure 17). If the cables are connected properly, then push the **FORCED BYPASS** button (Figure 5). If you do not see traffic, see Cause 4.2. If you see traffic, the cables may be reversed. Reconnect the cables so the antenna connects to the SL Rx input and the output connects to the base station.

**Cause 4.2**      Cables not mated or broken cable.

**Solution 4.2**    Remove cables one at a time, and do a physical inspection of the conductor and connectors. Use a DMM to check the center conductor. Replace any bad cables found. Recheck the RF cabling and try the RF performance test again.

**Cause 4.3**      Other.

**Solution 4.3**    Call the CS-Hotline.

**Problem 5      LED flashes RED and/or GREEN.**

**Cause 5.1**      SL Rx placed in Forced Bypass mode.

**Solution 5.1**      Push the **FORCED BYPASS** button (Figure 5) to allow a chance for the system to reach SuperLink mode (Regulate state). If the LED becomes steady, the system is no longer in Forced Bypass.

**Cause 5.2**      Other.

**Solution 5.2**      Call the CS-Hotline.

**Problem 6      Fuse blows out or circuit breaker trips.**

**Cause 6.1**      Incorrect voltage polarity applied.

**Solution 6.1**      Check that the voltage polarity matches the labels on the terminal block. If the polarity is correct, then continue with Cause 6.2. If the polarity is incorrect, change the polarity, replace the fuse, and/or reset the circuit breaker. Before you remove the fuse, turn off the circuit breaker to prevent injury.

**Cause 6.2**      Incorrect voltage applied.

**Solution 6.2**      Remove the fuse, close the circuit breaker, and check the voltage on the terminal block. The voltage should read  $27 \pm 2$  VDC, but if not call the CS-Hotline. Before you remove the fuse, turn off the circuit breaker to prevent injury.

**Cause 6.3**      Wrong circuit breaker rating.

**Solution 6.3**      Replace the fuse, and try again. Before you remove the fuse, turn off the circuit breaker to prevent injury. If the circuit breaker blows, check the rating. The circuit breaker rating should read 15 to 30 amps. Replace the circuit breaker if necessary.

**Cause 6.4**      Other.

**Solution 6.4**      Call the CS-Hotline.

**Problem 7**      **The SL Rx does not reach SuperLink mode (Regulate state) after five hours.**

**Cause 7.1**      SL Rx is in Forced Bypass mode.

**Solution 7.1**      Check if the LED is flashing GREEN. If so, the system is in Forced Bypass mode. Push the **FORCED BYPASS** button (Figure 5) to go back to SuperLink mode (Regulate state). When a steady **GREEN STATUS** LED displays, the system is in SuperLink mode (Regulate state). If the problem persists, call the CS-Hotline.

**Cause 7.2**      Source voltage is low under load.

**Solution 7.2**      Measure the voltage with a DMM. Replace the power wire and/or breaker if necessary.

**Cause 7.3**      Other.

**Solution 7.3**      Establish communication with the system using the System Status Portal (**Start > Programs > STI > STI System Status Portal**). With the program open, click **Communicate with Unit** to connect to a Comm Port, and establish communication with the SL Rx. To observe the Cold Stage Wide Range Temperature, from the System Status Portal, choose **View > Status > Measure**. Review the temperature. If the temperature is not in the range of  $79 \pm 4$  K, call the CS-Hotline.

**Problem 8 Alarm Relay Test failed.**

**Cause 8.1** Relay wire is not making a proper connection.

**Solution 8.1** Use an ohmmeter to measure connectivity from the SL Rx to the alarm relay. If either connection is bad, reset the wires or replace them and try connecting again. If both connections are good, see Cause 8.2.

**Cause 8.2** Alarm has been mis-wired.

**Solution 8.2** Ensure that the one wire is connected to the terminal block connection labeled **C** and one wire is connected to **NC** or **NO**.

**Cause 8.3** Alarm cable fault (alarm on, but front panel shows a steady GREEN LED).

**Solution 8.3** Inspect alarm cable and connections at both ends. Set and reset the alarm by using the **FORCED BYPASS** button (Figure 5) on the front panel, and check the operation at both ends of the alarm cable. See the “Connecting the Alarm Relay” section on page 32 for more information.

**Cause 8.4** Other.

**Solution 8.4** Call the CS-Hotline.

**Problem 9 Receive Path Gain Test failed.**

**Cause 9.1** Test setup error.

**Solution 9.1** Recheck the connection to the SL Rx, and try the receive path gain test again.

**Cause 9.2** Used wrong test frequency.

**Solution 9.2** Use 830 MHz A-band and 840 MHz B-band. The band is included in the Model Number (e.g. 850SLA2F1R(OL) is an A-band, and 850SLB2F1R(OL) is a B-band. Note that “OL” indicates the model number includes the Overlay model).

**Cause 9.3** Attempting to measure backwards or cross receive paths.

**Solution 9.3** Ensure that you inject the signal into the N-type input ports and that they are measured at the output ports with the same receive path number.

**Cause 9.4** Other.

**Solution 9.4** Call the CS-Hotline.

**Problem 10**     **In SuperLink mode (Regulate state), the alarm signals when the RF cable is connected between the SL Rx output and receive input.**

**Cause 10.1**     DC bias is on the center conductor of the coaxial cable.

**Solution 10.1**     Some base stations allow for DC bias on the coaxial line to provide power to a tower mount amplifier. Measure the DC bias from the center conductor to the ground of the receiver input. If there is bias, consult the Base Station documentation to turn off the Tower Top Amplifier bias voltage.

**Cause 10.2**     Tower Top Amplifier still connected.

**Solution 10.2**     Climb the tower and remove the Tower Top Amplifier. This causes problems for both the SL Rx input and/or output if the DC power is connected.

**Cause 10.3**     Other.

**Solution 10.3**     Call the CS-Hotline.

## Operation Troubleshooting

---

**Problem 11**     **Bypass LED is RED (Alarm is on).**

**Cause 11.1**     SL Rx has out-of-range condition.

**Solution 11.1**

- Establish communication with the system using the System Status Portal (**Start > Programs > STI > STI System Status Portal**). With the program open, click **Communicate with Unit** to connect to a Comm Port, and establish communication with the SL Rx. Verify the alarm and characterize the problem. Take note of any logged faults.
- If the problem is input power, use a DMM to investigate the problem. The input power should be between 25 to 30 VDC.
- If the problem persists, call the CS-Hotline.

**Cause 11.2**     Other.

**Solution 11.2**     Call the CS-Hotline.



**Problem 12**      **RF Performance is not optimal, detected by the following conditions:**

- **Degradation in statistical performance**
- **Customer complaints**
- **Base Station Built-in Test (BIT) failure**

**Cause 12.1**      Open/short in SL Rx receive path.

**Solution 12.1**      Check the gain of each receive path of the SL Rx, one receive path at a time. Inject the RF signal to the input of the SL Rx (A-Band 830 MHz, B-Band 840 MHz), and sample the signal at any point further up the RF chain. Check the measurement in SuperLink mode (Regulate state) and record. Place the system into Forced Bypass mode and then recheck the measurement. The difference between the two readings should be ~13 dB. Check each subsequent receive path in the same manner. If you discover a receive path that is not ~13 dB in SuperLink mode (Regulate state), but in Forced Bypass mode, call the CS-Hotline.

**Cause 12.2**      Other.

**Solution 12.2**      Call the CS-Hotline.

**Problem 13**      **Abnormal SL Rx noise.**

**Cause 13.1**      SL Rx becomes abnormally loud.

**Solution 13.1**

- Check for loose mounting hardware, cover screws, and other hardware.
- Check the panel. If the LEDs display RED and GREEN, the system may be recovering from power drop out. Wait three hours to allow it to recool. When the LEDs display GREEN, listen to the system again for normal vibration, and sound level.
- Check and/or clean the air filter.

**Cause 13.2**      Other.

**Solution 13.2**      Call the CS-Hotline.

---

## Chapter 7 Periodic Visual Inspection

---

### Visual Inspection Recommendations

---

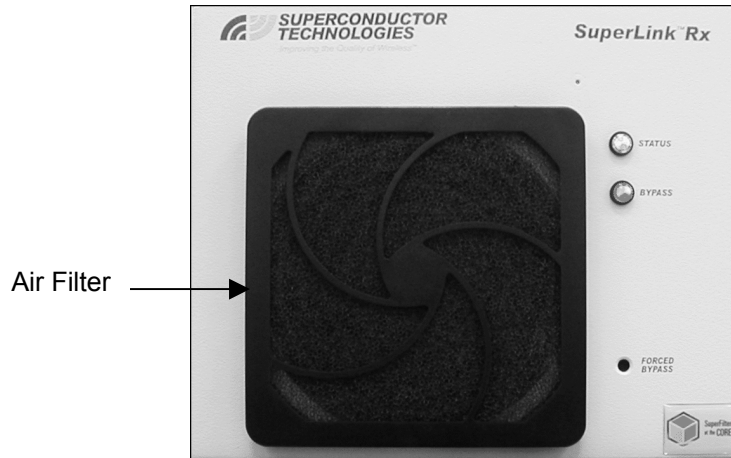
The SL Rx cryogenic cooling system is sealed and the electronic circuits are solid state, therefore, no maintenance is required. However, the following periodic visual inspection steps are suggested. The frequency of inspections depends on the installation site conditions.

- Look for loose electrical connections and loose components on rear panel of SL Rx.
- Look for frayed input power wires.
- Look for damaged RF cables.
- Check the front panel LEDs:
  - In SuperLink mode (Regulate state), the **STATUS** LED will be steady GREEN and the **BYPASS** LED will be off.
  - In Fault mode, the **STATUS** LED will be off and the **BYPASS** LED will be RED.
  - In Forced Bypass mode, the LEDs flash GREEN or RED based on the state of the system.
  - If the LED displays RED or flashes GREEN and/or RED, see Chapter 6, “Troubleshooting Tips” to resolve the problem.
- Check that the mounting hardware is tight and the SL Rx is securely mounted.
- Check that ventilation spaces in front and back of the SL Rx are clear.
- Feel for cooling air exiting the rear of the chassis. The fans run continuously and a steady flow of air should be evident.
- There is a single pop-out air filter mounted on the front panel that may be removed for inspection. Recommendations for cleaning the air filter follow in the next section.

## Cleaning the Air Filter

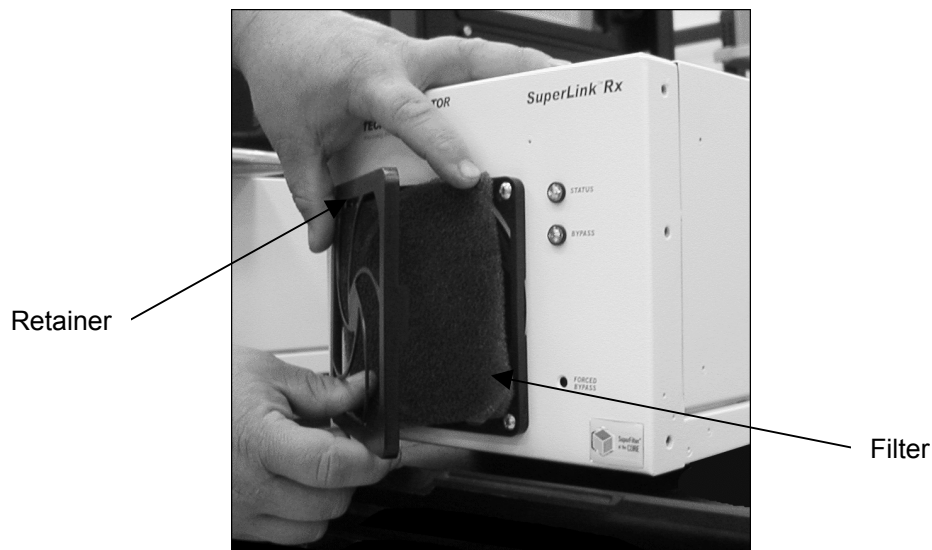
---

On an annual basis, inspect the air filter for dust and dirt accumulation that would impede the flow of air throughout the SL Rx. In some cases, the frequency of cleaning the air filter depends on the air quality of the site. Follow these instructions to clean the air filter periodically.



**Figure 18. Air Filter Location**

1. Located on the SL Rx front panel is a single pop-out air filter. Pull the air filter retainer towards you to remove the retainer.



**Figure 19. Removing the Air Filter Retainer**

2. Place the retainer aside, and remove the filter. Clean the filter with mild soap and water, and dry thoroughly.
3. When the filter is dry, place the filter over the fan, and snap the retainer into place.

---

# Appendix A Using the System Status Portal

---

## Overview

---

Included in the SL Rx package is the STI CD that contains the System Status Portal, and other resources required to run the program. Proper installation of the program will ensure communication between the SL Rx and the program on your PC. To install the System Status Portal, see Chapter 5, “Installing the SuperLink Rx” or review the **ReadMe.html** file on the STI CD.

The STI CD contains the following items:

- Application folder: Contains the System Status Portal.
- JavaRE folder: Contains the Java Runtime Environment required to support the System Status Portal.
- Manual folder: Contains the Operation and Installation manuals in Adobe Acrobat PDF, **Appendix C** in Microsoft<sup>®</sup> Excel, and the Adobe Acrobat Reader.
- ReadMe.html: Provides instructions to install the required programs on your PC.

## System Status Portal Interface

---

The System Status Portal provides a user-friendly interface to observe the operating parameters of the SL Rx. Explained in this section are the various buttons, menus, and fields to view the information you need to troubleshoot or verify proper operation of the system.

### Main Screen Buttons

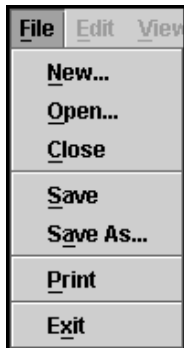
On the main screen of the System Status Portal, you will find two buttons at the bottom of the window. These buttons are shortcuts to menu items that are most commonly used.



- **Communicate with Unit**  
Opens a Comm Port (typically COM1) connection to establish communication with the SL Rx. Select the correct Comm Port to connect to the SL Rx. This button is the same as **File > New**.
- **View a Unit Record**  
Displays the **Open** dialog box, allowing you to choose an existing XML data file. This button is the same as **File > Open**.

## Menu Bar

### File Menu



- **New...**  
Opens a Comm Port connection to establish communication with the SL Rx. The System Status Portal lists the available Comm Ports on your PC. Select a Comm Port, then click **OK** to connect. You can also click **Communicate with Unit** on the main screen to open a file.

The following events open an error dialog box:

- When a Comm Port cannot be found.
- When the System Status Portal cannot talk to the SL Rx.

If you find an error, review Chapter 6, “Troubleshooting Tips” to troubleshoot the System Status Portal, or call the CS-Hotline.

- **Open...**  
Displays the **Open** dialog box, allowing you to choose an existing XML data file. You can also click **View a Unit Record** on the main screen to open a file.
- **Close**  
Closes the current session without saving, but does not exit the System Status Portal.
- **Save**  
Updates all the data records in the System Status Portal before saving them. The **File Save** dialog box opens if the data has not been previously saved. If you previously saved a file, the most recent data overwrites the previously saved file.
- **Save As...**  
Opens the **File Save As** dialog box, allowing you to change the filename and destination if you do not want to overwrite previous results.
- **Print**  
Prints the screen you are currently viewing.
- **Exit**  
Closes the current session and exits the System Status Portal without saving.

## Edit Menu



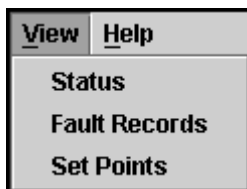
The **Edit** menu is available when you have established a connection with the SL Rx or use **File > Open**. This menu allows you to copy information to the Windows clipboard, and paste the information to another program such as Microsoft® Word, Notepad, or WordPad.

- **Copy**  
Copies text from a current tab to the Windows clipboard. You can paste the information to another program such as Microsoft® Word, Notepad, or WordPad.
- **Password...**  
Opens the **Logon Information** dialog box to enter a valid password to change or clear values in the Set Points and Fault Records.



The Password feature is for STI Customer Service only.

## View Menu



The **View** menu allows you to review information about the operation, fault records, and values of the SL Rx.

- **Status**  
Displays the operating status of the SL Rx. See the “Status View” section on page 59 for more information.
- **Fault Records**  
Displays the status of the faults, showing the first and last occurrence. Only STI can clear the faults in this view. See the “Fault Records View” section on page 65 for more information.



Clearing faults in this view is for STI Customer Service use only.

- **Set Points**  
Displays the values that configure the operation of the SL Rx and debugging information.



Changing values in this view is for STI Customer Service use only.

## Help Menu



The **Help** menu contains information about the System Status Portal and how to contact STI Customer Service.

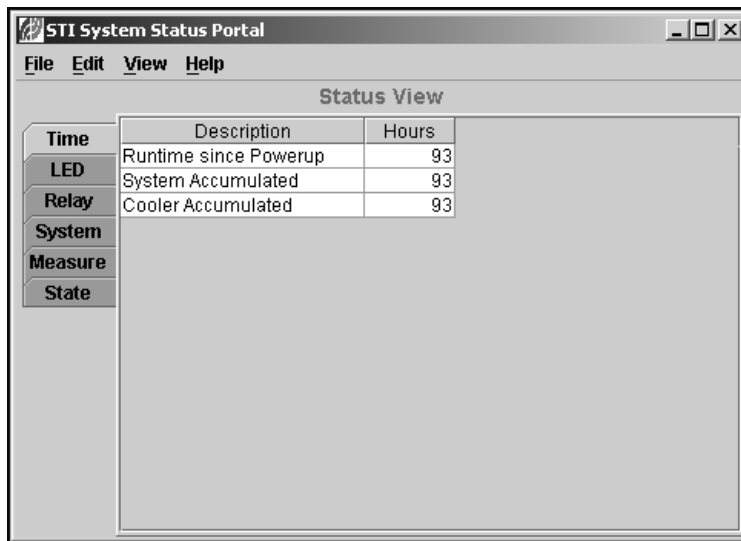
- **Support...**  
Opens the dialog box containing the CS-Hotline information.
- **About...**  
Opens the dialog box containing the version number and the date the System Status Portal was built.

## Status View

The **Status View** displays the operating status of the system.

### Time Tab

The **Time tab** displays the run and accumulated operating times in hours.

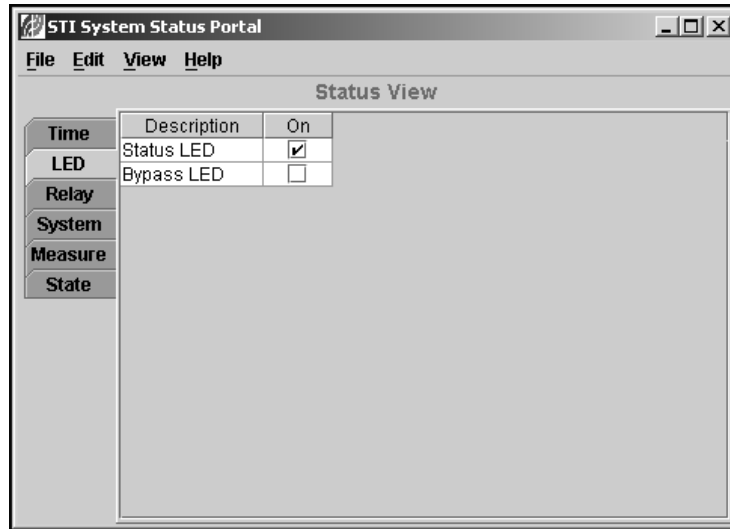


- **Runtime since Powerup**  
Displays the time the system has been running since power was last applied to the system.
- **System Accumulated**  
Displays the total accumulated time the system has been powered on.
- **Cooler Accumulated**  
Displays the total accumulated time the cooler has been powered on.



## LED Tab

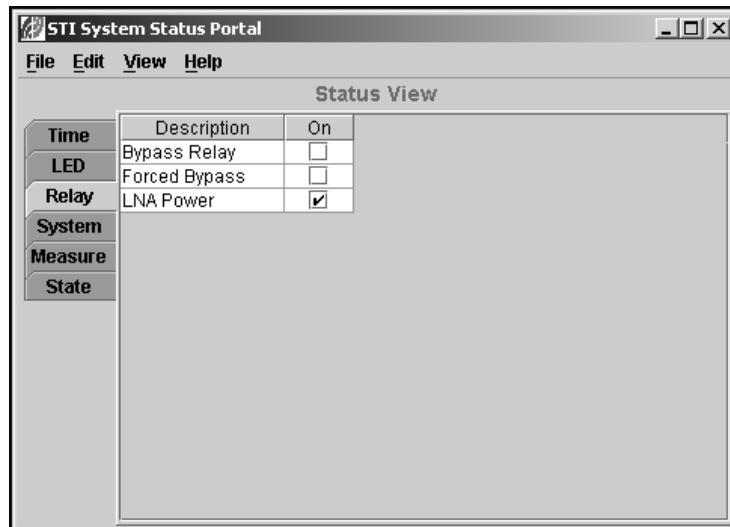
The **LED tab** displays the state of the LEDs on the system.



- **Status LED**
  - STATUS LED turned on (GREEN).
  - STATUS LED turned off.
- **Bypass LED**
  - BYPASS LED turned on (RED).
  - BYPASS LED turned off.

## Relay Tab

The **Relay tab** displays the state of the relays or power to the LNAs.



- **Bypass Relay**
  - Bypass Relay is on.
  - Bypass Relay is off.
- **Forced Bypass**
  - Forced Bypass is on.
  - Forced Bypass is off.
- **LNA Power**
  - LNA Power is on.
  - LNA Power is off.

### System Tab

The **System tab** shows the operating status of the SL Rx features, control loops, and operating limits.

The screenshot shows a window titled "STI System Status Portal" with a menu bar (File, Edit, View, Help) and a "Status View" section. On the left, there are expandable tabs: Time, LED, Relay, System, Measure, and State. The "System" tab is selected, showing a table of status items with checkboxes in the "True" column.

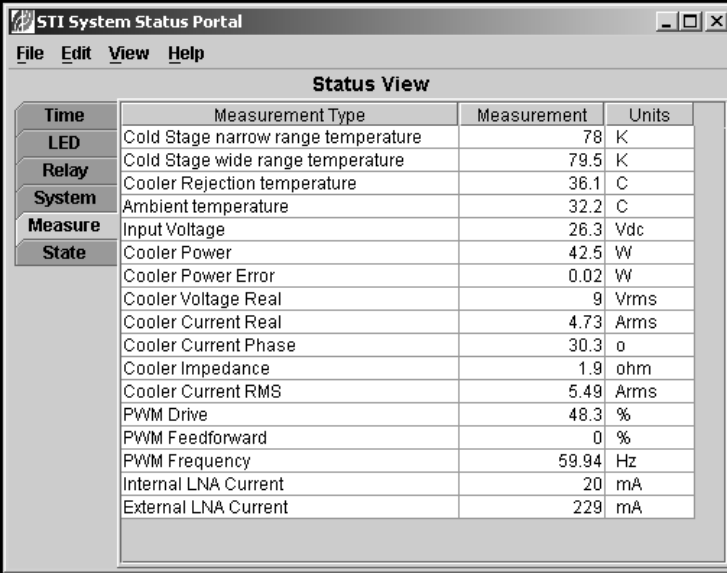
Time	Status Type	True
LED	LNA Power On	<input checked="" type="checkbox"/>
Relay	Power/Current Loop Regulating	<input checked="" type="checkbox"/>
System	Power Loop Active	<input checked="" type="checkbox"/>
Measure	Power Duty Limit Exceeded	<input type="checkbox"/>
State	Power Drive Limit Foldback	<input type="checkbox"/>
	Auto Frequency Adjust	<input checked="" type="checkbox"/>
	Temperature Loop Regulating	<input checked="" type="checkbox"/>
	Cold Stage narrow range temperature out of bounds	<input type="checkbox"/>
	Cold Stage wide range temperature out of bounds	<input type="checkbox"/>
	Cooler Rejection temperature out of bounds	<input type="checkbox"/>
	Ambient temperature out of bounds	<input type="checkbox"/>

- **LNA Power On**
  - LNA power turned on.
  - LNA power turned off.
- **Power/Current Loop Regulating**
  - Power or current loop regulates within tolerance.
  - Power or current loop is not regulating within tolerance.
- **Power Loop Active**
  - Power loop is the active loop.
  - Current loop is the active loop.

- **Power Duty Limit Exceeded**
  - Power duty cycle has exceeded the maximum limit.
  - Power duty cycle has not exceeded the maximum limit.
- **Power Drive Limit Foldback**
  - Power maximum drive level is folding back on a limit.
  - Power maximum drive level is off the cooldown table.
- **Auto Frequency Adjust**
  - SL Rx automatically adjusts the operating cooler drive frequency to minimize vibration.
  - SL Rx operating frequency remains constant.
- **Temperature Loop Regulating**
  - Temperature loop regulates within tolerance.
  - Temperature loop is not regulating within tolerance.
- **Cold Stage narrow range temperature out of bounds**
  - Cold Stage narrow range temperature is out of normal operating bounds.
  - Cold Stage narrow range temperature is within normal operating bounds.
- **Cold Stage wide range temperature out of bounds**
  - Cold Stage wide range temperature is out of normal operating bounds.
  - Cold Stage wide range temperature is within normal operating bounds.
- **Cooler Rejection temperature out of bounds**
  - Cooler Rejection temperature is out of normal operating bounds.
  - Cooler Rejection temperature is within normal operating bounds.
- **Ambient temperature out of bounds**
  - Ambient temperature is out of normal operating bounds.
  - Ambient temperature is within normal operating bounds.

## Measure Tab

The **Measure tab** displays either the current or previously saved system temperature, cooler drive, and LNA measurements.



The screenshot shows the 'STI System Status Portal' window with the 'Measure' tab selected. The 'Status View' table displays various system parameters and their current values.

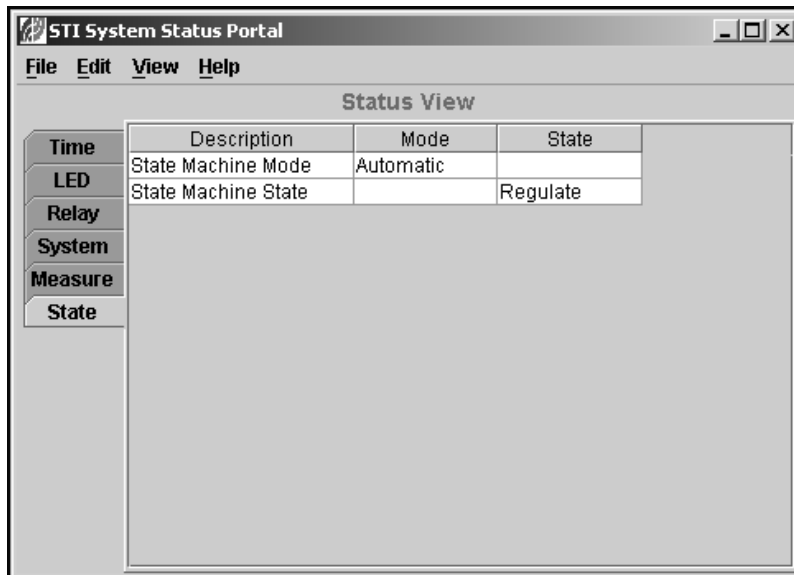
Time	Measurement Type	Measurement	Units
LED	Cold Stage narrow range temperature	78	K
Relay	Cold Stage wide range temperature	79.5	K
System	Cooler Rejection temperature	36.1	C
Measure	Ambient temperature	32.2	C
State	Input Voltage	26.3	Vdc
	Cooler Power	42.5	W
	Cooler Power Error	0.02	W
	Cooler Voltage Real	9	Vrms
	Cooler Current Real	4.73	Arms
	Cooler Current Phase	30.3	o
	Cooler Impedance	1.9	ohm
	Cooler Current RMS	5.49	Arms
	PWM Drive	48.3	%
	PWM Feedforward	0	%
	PWM Frequency	59.94	Hz
	Internal LNA Current	20	mA
	External LNA Current	229	mA

- **Cold Stage narrow range temperature**  
Displays the Cold Stage narrow range temperature measured in K.
- **Cold Stage wide range temperature**  
Displays the Cold Stage wide range temperature measured in K.
- **Cooler Rejection temperature**  
Displays the Cooler Rejection temperature measured in °C.
- **Ambient temperature**  
Displays the Ambient temperature measured in °C.
- **Input Voltage**  
Displays the Input Voltage measured in VDC.
- **Cooler Power**  
Displays the Cooler motor drive real Power measured in W.
- **Cooler Power Error**  
Displays the Cooler motor drive real Power error measured in W.
- **Cooler Voltage Real**  
Displays the Cooler motor drive real voltage measured in VRMS.
- **Cooler Current Real**  
Displays the Cooler motor drive real current measured in ARMS.
- **Cooler Current Phase**  
Displays the Cooler motor drive current phase referenced to voltage, in degrees.

- **Cooler Impedance**  
Displays the Cooler motor drive impedance measured in ohms.
- **Cooler Current RMS**  
Displays the Cooler motor drive total current measurement in ARMS.
- **PWM Drive**  
Displays the Cooler motor drive pulse width modulation measured in %.
- **PWM Feedforward**  
Displays the Cooler motor drive feedforward gain measured in %.
- **PWM Frequency**  
Displays the Cooler motor drive sine wave frequency measured in Hz.
- **Internal LNA Current**  
Displays the Internal LNA Current measured in mA.
- **External Current**  
Displays the External LNA Current measured in mA.

### State Tab

The **State tab** indicates the state machine status of the SL Rx.



- **State Machine Mode**  
Displays the operating mode of the SL Rx. In Automatic mode, the system will automatically sequence through the states. In Manual mode, the operator manually changes states by selecting the state.
- **State Machine State**  
Displays the operating state of the SL Rx. See Table 7 for more information about the states.

## Fault Records View

The **Fault Records View** displays the status of the faults, showing the first and last occurrence. If you find any active faults, call the CS-Hotline.

Status	Fault Type	Record	Active	Clear
Pm First	Pm - Power Loop regulation fault?	<input type="checkbox"/>	<input type="checkbox"/>	<input type="checkbox"/>
Pm Last	Tcsw - Cold Stage wide range temperature out of operating range fault?	<input type="checkbox"/>	<input type="checkbox"/>	<input type="checkbox"/>
Tcsw First	Trej - Cooler Rejection temperature exceeds operating range fault?	<input type="checkbox"/>	<input type="checkbox"/>	<input type="checkbox"/>
Tcsw Last	Tcsn - Temperature Loop regulation fault?	<input type="checkbox"/>	<input type="checkbox"/>	<input type="checkbox"/>
Trej First	Ilina - LNA current exceeds operating range fault?	<input type="checkbox"/>	<input type="checkbox"/>	<input type="checkbox"/>
Trej Last	Vin - Input Voltage exceeds operating range fault?	<input type="checkbox"/>	<input type="checkbox"/>	<input type="checkbox"/>
Tcsn First	Duty - Duty Cycle exceeds operating range fault?	<input checked="" type="checkbox"/>	<input type="checkbox"/>	<input type="checkbox"/>
Tcsn Last				
Ilina First				
Ilina Last				
Vin First				
Vin Last				
Duty First				
Duty Last				

### Status Tab

The Status tab displays the status of each fault:


- Record**  
The fault was recorded for either the first or last occurrence.
- Active**  
The fault is currently active.
- Clear**  
For STI Customer Service only. Call the CS-Hotline to clear faults that appear in this tab.

If your system experiences a fault, review Chapter 6, “Troubleshooting Tips” to troubleshoot your system or call the CS-Hotline for assistance.

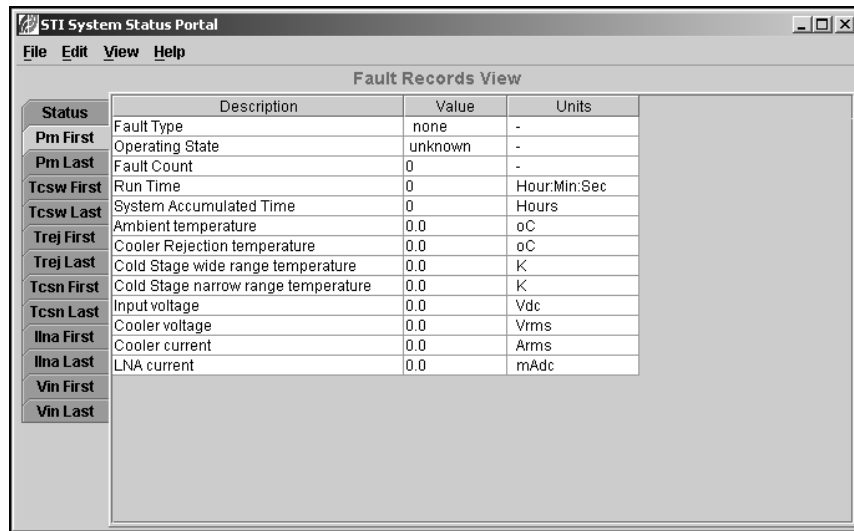
- **PM-Power Loop regulation fault?**  
A Power or Current Loop out of regulation fault was recorded.
- **Tcsw-Cold Stage wide range temperature out of operating range fault?**  
A Cold Stage wide range temperature out of bounds fault was recorded.
- **Trej-Cooler Rejection temperature exceeds operating range fault?**  
A Cooler rejection temperature out of bounds fault was recorded.
- **Tcsn-Temperature Loop regulation fault?**  
A Temperature Loop out of regulation fault was recorded.

- **Ilna-LNA current exceeds operating range fault?**  
A LNA current out of bounds fault was recorded. The reason for the fault may be due to the internal or external LNA.
- **Vin-Input Voltage exceeds operating range fault?**  
An Input Voltage out of bounds fault was recorded.
- **Duty-Duty Cycle exceeds operating range fault?**  
The Duty Cycle exceeded the maximum fault was recorded. This does not affect the active fault indication.

### PM First Tab

 Since the tabs in the **Fault Records View** contain the same fields, only the **PM First and Last tabs** are described. The following tabs will only describe the type of faults that occurred.

The PM First tab shows the fault for the first occurrence of a power loop out of regulation or cooler impedance fault.



Status	Description	Value	Units
Pm First	Fault Type	none	-
Pm Last	Operating State	unknown	-
Pm First	Fault Count	0	-
Tcsw Last	Run Time	0	Hour:Min:Sec
Tcsw Last	System Accumulated Time	0	Hours
Trej First	Ambient temperature	0.0	oC
Trej First	Cooler Rejection temperature	0.0	oC
Trej Last	Cold Stage wide range temperature	0.0	K
Tcsn First	Cold Stage narrow range temperature	0.0	K
Tcsn Last	Input voltage	0.0	Vdc
Ilna First	Cooler voltage	0.0	Vrms
Ilna First	Cooler current	0.0	Arms
Ilna Last	LNA current	0.0	mAdc
Vin First			
Vin Last			

- **Fault Type**  
Two types of faults that trigger this record: a power loop out of regulation fault or cooler motor impedance out of bounds fault.
- **Operating State**  
Displays the state machine state when this fault occurred. The states are defined in Table 7.
- **Fault Count**  
Displays the number of times this fault record was written. The first occurrence will always be one if the fault occurred. The last occurrence will be one if the fault occurred twice and the number of times the fault occurred less one subsequently.

- **Run Time**  
Displays the time since the system was last powered up in Hours:Minutes:Seconds when this fault occurred.
- **System Accumulated Time**  
Displays the number of hours the system had operated when this fault occurred.
- **Ambient temperature**  
Displays the ambient temperature in °C when this fault occurred.
- **Cooler Rejection temperature**  
Displays the cooler rejection temperature in °C when this fault occurred.
- **Cold Stage wide range temperature**  
Displays the cold stage wide range temperature in K when this fault occurred.
- **Cold Stage narrow range temperature**  
Displays the cold stage narrow range temperature in K when this fault occurred.
- **Input voltage**  
Displays the input voltage in Vdc when this fault occurred.
- **Cooler voltage**  
Displays the cooler motor voltage in real part Vrms when this fault occurred.
- **Cooler current**  
Displays the cooler motor current in real part Arms when this fault occurred.
- **LNA current**  
Displays the LNA current in mAdc when this fault occurred. If an LNA fault occurred, it is either an internal or external LNA fault current. Otherwise, the fault is an internal LNA current.

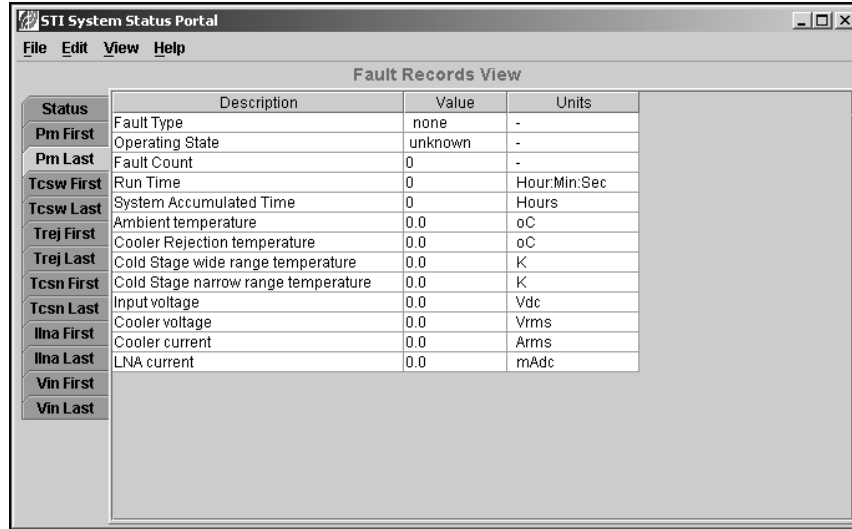


For the **Ilna First and Last tabs** only. The LNA current displays the LNA current in mAdc when this fault occurred. If an LNA fault occurred, it is either an internal or external LNA fault current, depending on whether the fault was an internal or external LNA fault.



## ***PM Last Tab***

The **PM Last tab** shows the last occurrence of a power loop out of regulation or cooler impedance fault.



Status	Description	Value	Units
<b>Pm First</b>	Fault Type	none	-
<b>Pm Last</b>	Operating State	unknown	-
<b>Pm First</b>	Fault Count	0	-
<b>Tcsw First</b>	Run Time	0	Hour:Min:Sec
<b>Tcsw Last</b>	System Accumulated Time	0	Hours
<b>Trej First</b>	Ambient temperature	0.0	oC
<b>Trej Last</b>	Cooler Rejection temperature	0.0	oC
<b>Tcsn First</b>	Cold Stage wide range temperature	0.0	K
<b>Tcsn Last</b>	Cold Stage narrow range temperature	0.0	K
<b>Ilna First</b>	Input voltage	0.0	Vdc
<b>Ilna Last</b>	Cooler voltage	0.0	Vrms
<b>Vin First</b>	Cooler current	0.0	Arms
<b>Vin Last</b>	LNA current	0.0	mAdc

## ***Tcsw First /Tcsw Last Tabs***

The **Tcsw First/Tcsw Last tabs** show the first and last occurrence of a cold stage wide range temperature out of bounds fault.

## ***Trej First/Trej Last Tabs***

The **Trej First/Trej Last tabs** show the first occurrence of a cooler rejection temperature out of bounds fault.

## ***Tcsn First/Tcsn Last Tabs***

The **Tcsn First/Tcsn Last tabs** show the first occurrence of a temperature loop out of regulation fault.

## ***Ilna First/Ilna Last Tabs***

The **Ilna First/Ilna Last tabs** show the first occurrence of either an internal or external LNA current out of bounds fault.

## ***Vin First/Vin Last Tabs***

The **Vin First/Vin Last tabs** show the first occurrence of an input voltage out of bounds fault.

## ***Duty First/Duty Last Tabs***

The **Duty First/Duty Last tabs** show the first occurrence of a duty cycle exceeded the maximum fault.

# Appendix B SuperLink Rx Specifications

Specifications provided for the SL Rx consist of power requirements, physical characteristics, and environmental limitations.

For RF performance specifications, see the data sheets for your model.

**Table 8. SuperLink Rx Specifications**

Item	Characteristic
<b>Power Requirements</b>	
Input Power Voltage (+27V Nominal)	22.5 to 30 VDC input power
Input Power Interface	Screw Terminal Block
Fuse	10A Fast-Blow
Maximum Input Power at 0 to 50°C Ambient Temperature	195 Watts Maximum (at cooldown only)
Steady-State Input Power at 23°C Ambient Temperature 2-Pak System	70 Watts Typical
Steady-State Input Power at 23°C Ambient Temperature 6-Pak System	80 Watts Typical
<b>Dimensions</b>	
2-Pak System	7 inches (H) x 8.4 inches (W) x 23 inches (D)
6-Pak System	
<b>SL Rx Weight (excluding Rack Mount Brackets)</b>	
2-Pak System	32.5 lbs
6-Pak System	34 lbs
<b>SL Rx Weight (with Overlay model, excluding Rack Mount Brackets)</b>	
2-Pak System	34 lbs
6-Pak System	35.5 lbs
<b>Rack Mount Brackets Weight</b>	
19-inch Rack Mount Brackets (pair)	3 lbs
23-inch Rack Mount Brackets (pair)	4 lbs
<b>Environmental</b>	
Operating Temperature	0°C to +50°C
Operating Humidity	5% to 85% RH at 31°C
Operating Altitude	Sea level to 10,000 feet above sea level
Storage Temperature (Non-Operating)	-40°C to +70°C
Storage Humidity (Non-Operating)	10% to 95% RH non-condensing at 40°C
Storage Altitude (Non-Operating)	Sea level up to 45,000 feet
Electrostatic Sensitive Devices that require Electrostatic Discharge Protection	The SL Rx contains components that are subject to damage from electrostatic discharge (ESD). Take precautionary measures when handling components mounted at the rear of the system.



# Appendix C Receive Path Gain/Loss Calculator

For your convenience, this record is also available as a Microsoft® Excel file located in the **SuperLink Rx Operation and Installation Manual** folder on the STI CD.

## Standard Model

Reference Measured: Frequency = \_\_\_\_\_ Power Level = \_\_\_\_\_

Mode	Receive Path Number	Signal Generator Frequency Power Level (-50 dBm nominal)	Measured Output Level	Gain/Loss Calculation
<b>Example</b>				
<b>Bypass</b>	<b>Example</b>	<b>-50.5 dBm</b>	<b>-51.0 dBm</b>	<b>-0.5 dB</b>
<b>SL Rx</b>	<b>Example</b>	<b>-50.5 dBm</b>	<b>-37.3 dBm</b>	<b>+13.2 dB</b>
Bypass	1			
SL Rx	1			
Bypass	2			
SL Rx	2			
Bypass	3			
SL Rx	3			
Bypass	4			
SL Rx	4			
Bypass	5			
SL Rx	5			
Bypass	6			
SL Rx	6			

## SL Rx with Overlay Model

Reference Measured: Frequency = \_\_\_\_\_ Power Level = \_\_\_\_\_

Mode	Receive Path Number	Signal Generator Frequency Power Level (-50 dBm nominal)	Measured Output Level	Gain/Loss Calculation
<b>Example</b>				
<b>Bypass</b>	<b>Example</b>	<b>-50.5 dBm</b>	<b>-54.1 dBm</b>	<b>-3.6 dB</b>
<b>SL Rx A</b>	<b>Example</b>	<b>-50.5 dBm</b>	<b>-41.8 dBm</b>	<b>+8.7 dB</b>
<b>SL Rx B</b>	<b>Example</b>	<b>-50.5 dBm</b>	<b>-41.1 dBm</b>	<b>+9.4 dB</b>
Bypass	1			
SL Rx	1A			
SL Rx	1B			
Bypass	2			
SL Rx	2A			
SL Rx	2B			
Bypass	3			
SL Rx	3A			
SL Rx	3B			
Bypass	4			
SL Rx	4A			
SL Rx	4B			
Bypass	5			
SL Rx	5A			
SL Rx	5B			
Bypass	6			
SL Rx	6A			
SL Rx	6B			



---

# Index

---

- A**
- air filter
    - cleaning, 54
  - alarm relay
    - connection, 32
    - states, 45
    - test, 37
- B**
- Bypass LED, 10
  - Bypass state, 34
- C**
- Cascade configuration, 6
    - 2-Pak overlay rear panel, 12
    - 2-Pak rear panel, 11
    - 6-Pak overlay rear panel, 13
    - 6-Pak rear panel, 12
    - cabling diagram, 44
    - gain test setup, 41
    - RF connections, 42
    - RF connections for overlay, 43
  - caution symbol, 3
  - chassis ground installation, 31
  - console connection and operation, 35
  - Cooldown state, 34
  - cryogenic cooling, 8
  - Customer Service Hotline (CS-Hotline), 3
- D**
- Digital Signal Processor (DSP), 8
- E**
- Electrostatic Discharge (ESD), 3
  - equipment configurations, 5
  - equipment specifications, 69
  - equipment supplied, 15
  - ESD. *See* electrostatic discharge.
- F**
- Fault Records view, 65
    - Ilna First tab, 68
    - Ilna Last tab, 68
    - PM First tab, 66
    - PM Last tab, 68
    - Status tab, 65
    - Tcsn First tab, 68
    - Tcsn Last tab, 68
    - Tcsw First tab, 68
    - Tcsw Last tab, 68
    - Trej First tab, 68
    - Trej Last tab, 68
    - Vin First tab, 68
    - Vin Last tab, 68
  - filter. *See* air filter.
  - Forced Bypass button, 10
  - Forced Bypass state, 34
  - front panel indicators and controls, 10
  - functional checks, 35
    - alarm relay connection, 32
    - alarm relay test, 37
    - console connection, 35
    - receive path gain test, 39
    - test generator calibration data, 38
- G**
- gain test setup, 41
  - general safety
    - cautions, 3
    - notes, 3
    - warnings, 3
- H**
- hand tools required, 20
- I**
- Initial state, 34
  - inspection procedures, 53
  - installation

- alarm relay, 32
- chassis ground, 31
- internal states and status, 34
- Java Runtime Environment, 23
- materials required, 20
- mounting the SL Rx, 30
- power wire, 31
- site requirements, 19
- supply and material requirements, 20
- System Status Portal, 27
- test equipment required, 21
- troubleshooting, 46

internal states and status, 34

## J

- Java Runtime Environment, 21

## M

- maintenance, 53
- materials required, 20
- model number, 13
- mounting the SL Rx, 30

## N

- note symbol, 3

## O

- operation troubleshooting, 51
- overlay model, 6

## P

- packing instructions, 18
- PC requirements, 21
- power terminal block, 8
- power wire installation, 31
- powering up, SuperLink Rx, 33

## R

- rack mount bracket installation, 31
- rear panel connectors and controls
  - 2-Pak, 11
  - 2-Pak overlay, 12
  - 6-Pak, 12
  - 6-Pak overlay, 13
- receive path gain test, 39

- receive path gain/loss calculator, 71
- receive path gain/loss calculator for overlay, 71
- Regulate state, 34
- Return Material Authorization (RMA), 17
- return shipments, 17
- RF connections
  - Cascade, 42, 43
  - Overlay, 43
- RF signal flow, 7

## S

- safety. *See* general safety.
- Shutdown state, 34
- STATUS LED, 10
- Status view, 59
  - LED tab, 60
  - Measure tab, 63
  - Relay tab, 60
  - State tab, 64
  - System tab, 61
  - Time tab, 59
- SuperLink mode, 34
- supply and material requirements
  - for installation, 20
- System Status Portal
  - communication with SuperLink Rx, 55
  - Edit menu, 58
  - Fault Records view, 65
  - File menu, 57
  - Help menu, 59
  - installation, 27
  - interface, 55
  - Java Runtime Environment, 21
  - main screen buttons, 56
  - PC requirements, 21
  - Status view, 59
  - using the, 55
  - View menu, 58

## T

- technical assistance, 3
- test equipment required, 21
- test generator calibration data, 38
- troubleshooting tips, 45
  - installation, 46

operation, 51

## U

unpacking the SL Rx, 16

## W

warning symbol, 3

warranty, 4





SuperLink™ Rx is a trademark of Superconductor Technologies Inc. (STI).  
All other marks are properties of their respective owners.

©Superconductor Technologies Inc (STI), 2002-2004. All Rights Reserved.  
Information in this manual is subject to change without notice. Reproduction, adaptation, or translation  
without prior written permission is prohibited, except as allowed under the copyright laws.

STI part number: 830-0013E. Last updated: 3/5/04.