

CM2125

Computer Monitor Analyzer

Parts List & Schematic

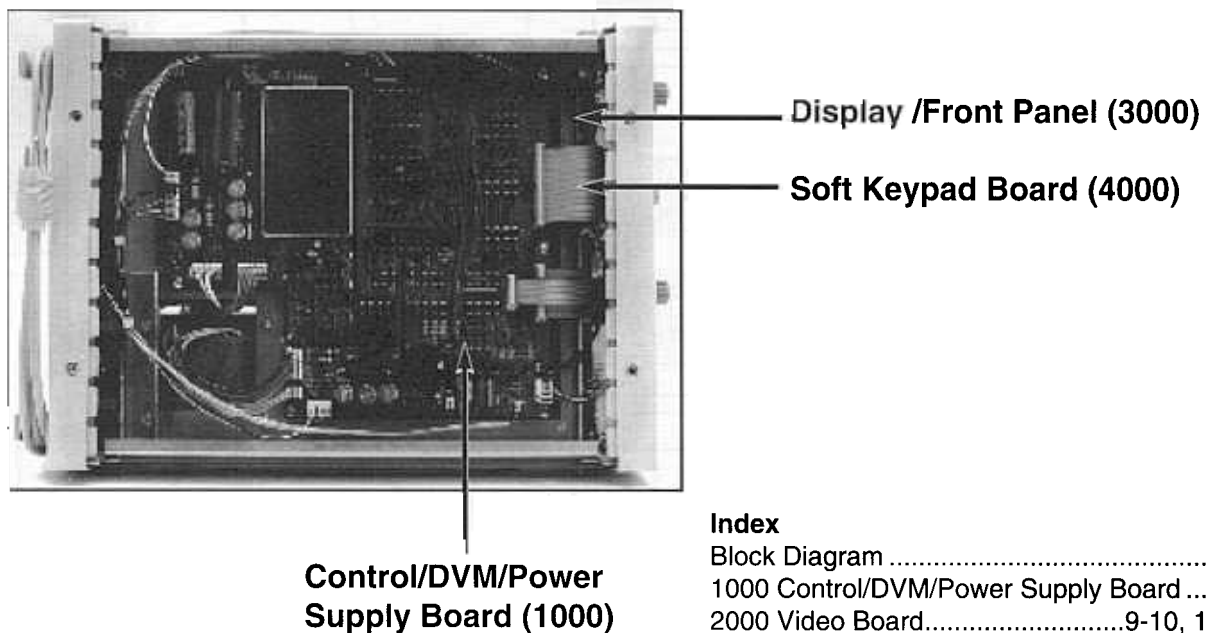
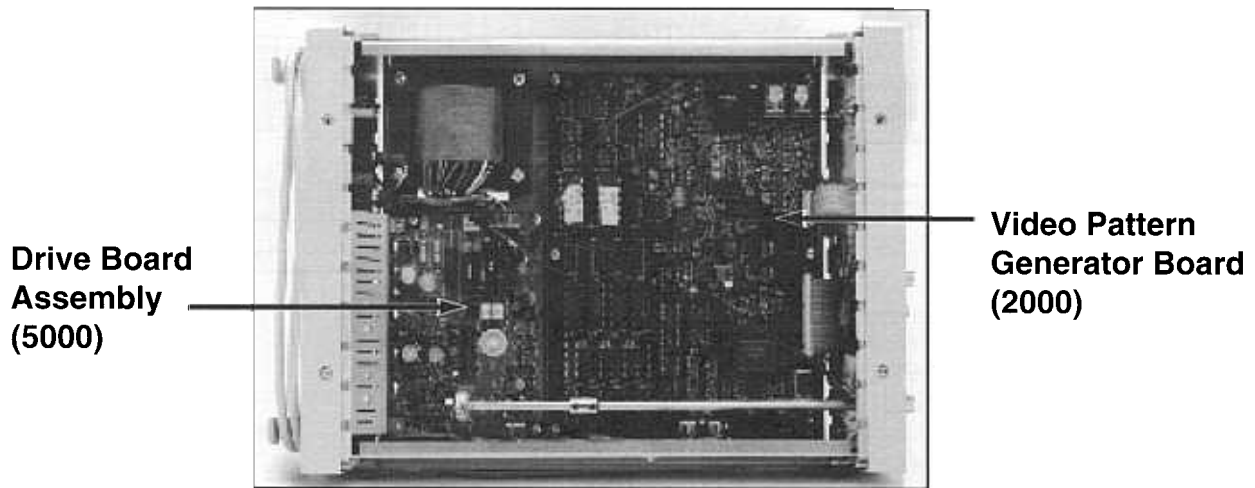

| Index | Page |
|---|-----------------|
| Block Diagram | 12-13 |
| 1000 Control/DVM/Power Supply Board | 2-8 |
| 2000 Video Board..... | 9-10, 11, 14-17 |
| 3000 Front Panel..... | 18-19 |
| 4000 Keyboard Board..... | 20-21 |
| 5000 Drive Board..... | 22-23 |
| 6000 EMI Board..... | 10 |
| Miscellaneous Parts List..... | 10 |

This booklet contains schematic, board legend, and parts list for each board.

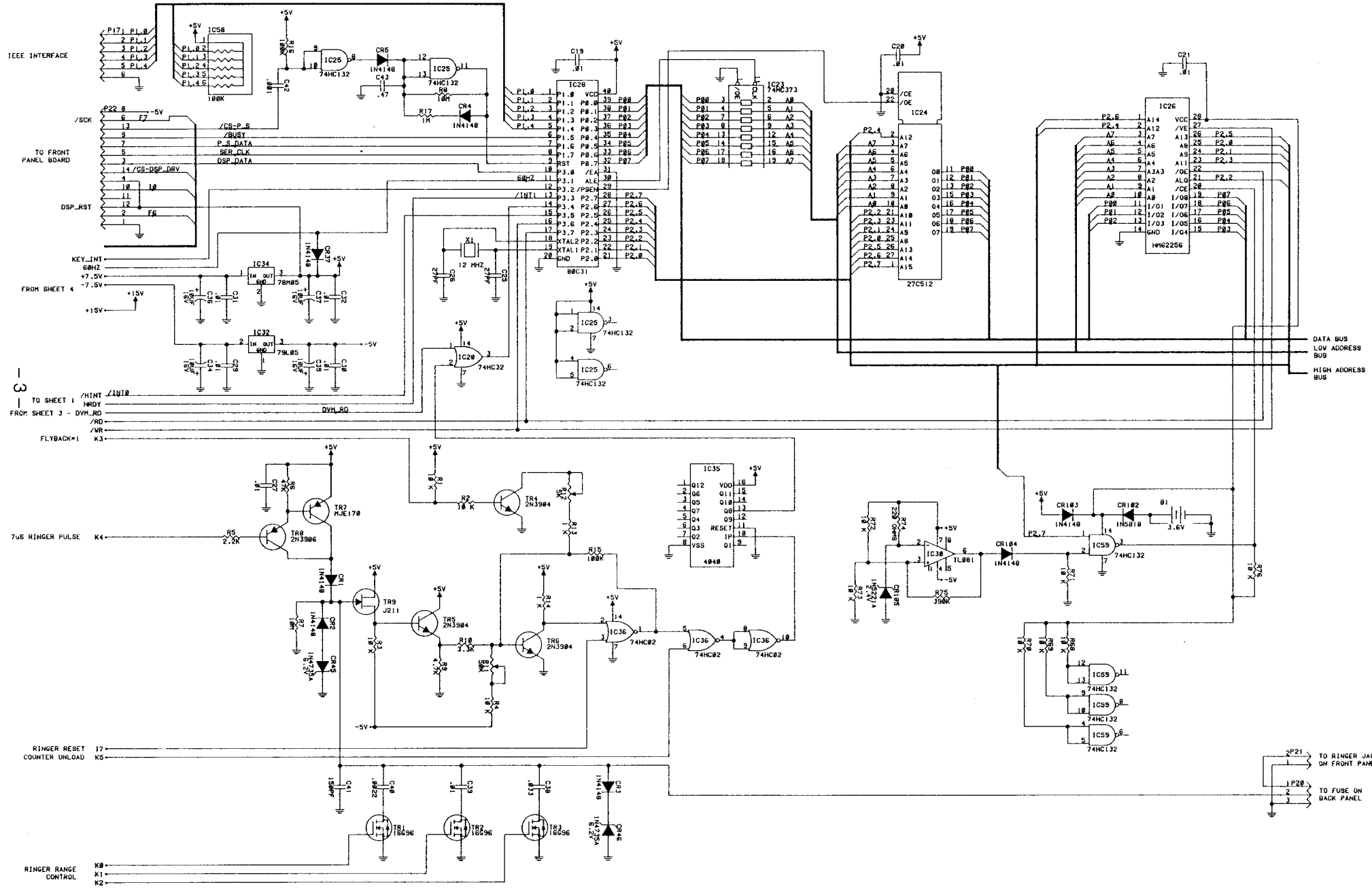

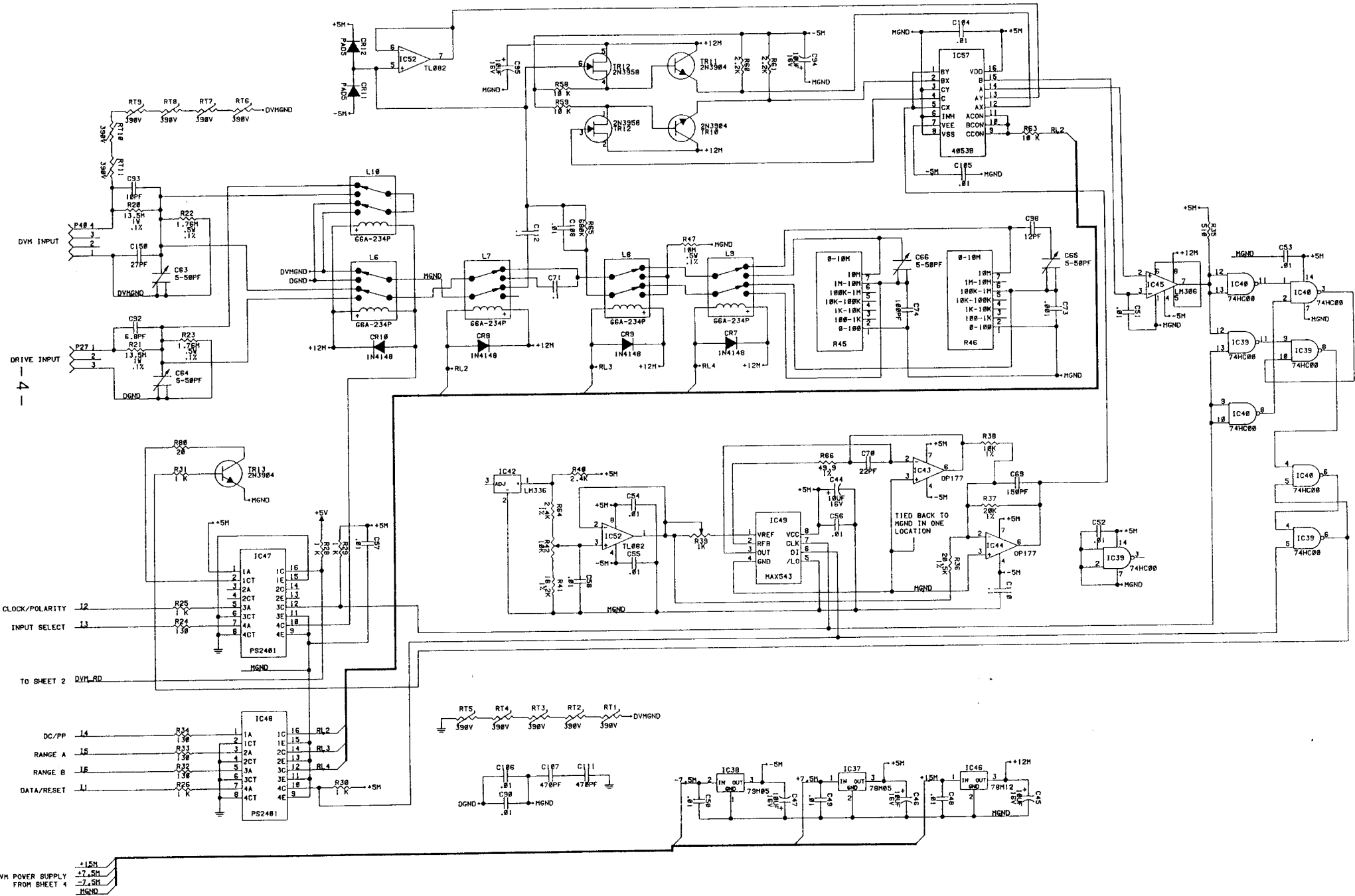

+12V
+5V
-5V
DGND

DVM POWER SUPPLY FROM SHEET 4

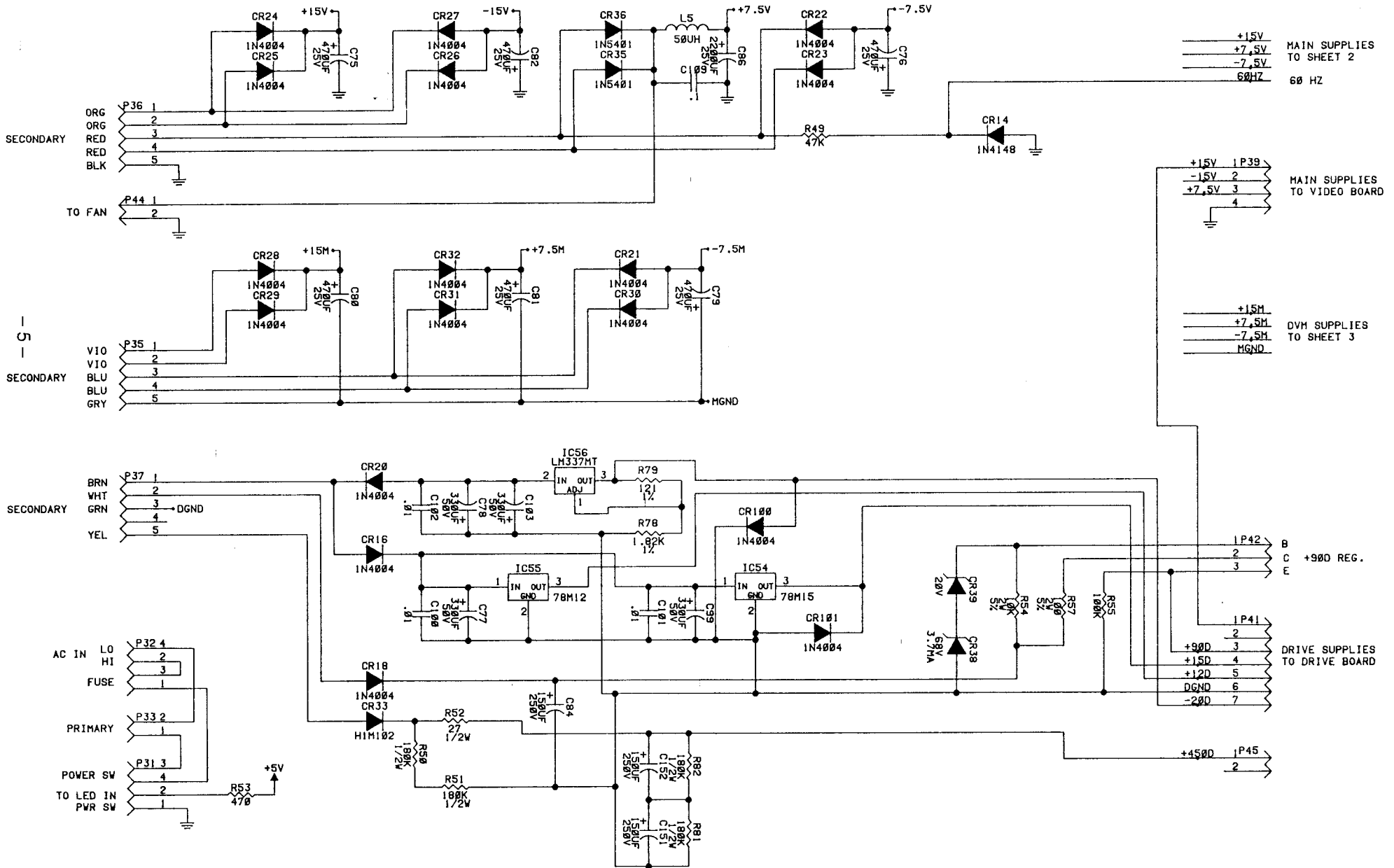

| Schematic References | Component | Part Description |
|--|-------------|-----------------------------------|
| 1000 Control/DVM/Power Supply Board | | |
| B1 | 17Z13 | BATTERY, LITHIUM, 3V |
| CR36,35 CLIP LEADS | 16G14 | DIODE, PWR COMP, 100V, 3A, 5401 |
| CR38 CLIP LEADS | 50C4-20 | DIODE, ZENER, 68V, 5%, 5W, 1N5373 |
| RT1,6,7,8,9,10,11,2,3,4,5 CLIP | 33G251 | VARISTOR, 390V, +/- 10% |
| R78 | 14A38-1823A | RES, MET.F, 1.82K, 1/4W, 1%, 100P |
| R79 | 14A38-1212A | RES, MET.F, 121, 1/4W, 1%, 100PPM |
| R51,50,82,81 | 14C4-184 | RES, CARBON, 180K, 1/2W, 5% |
| CR33 | 16G23 | DIODE, SILICON, 1.3KV, 1A, 5UA, T |
| R52 | 14C4-270 | RES, CARBON, 27, 1/2W, 5% |
| CR100,101,20,18,16,31,30,21,32 | 16G10 | DIODE, SIL, 400V, 1A, 5UA, 1N4004 |
| R54 | 14C10-103 | RES, CARBON, 10K, 2W, 5% |
| CR39 | 50C4-8 | DIODE, ZENER, 20V, 45MA, 5%, 1N47 |
| R57 | 14C10-101 | RES, CARBON, 100, 2W, 5% |
| C102,101,100,49,50 | 24G483 | CAP, MYLAR, .01UF, 50V, 5%, 5MM |
| IC56,55,54 | 67G50 | HEATSINK, TO-220 |
| IC56 | 69G287 | IC, REG, NEG, ADJ, LM337T |
| IC55 | 69G135 | IC, REG, +12V, 500MA, 78M12 |
| IC54 | 69G105 | IC, REG, +15V, 500MA, 78M15 |
| C78,103,99,77 | 24G408 | CAP, RLYTIC, 330UF, 50V, +/- 20% |
| IC37 | 69G70 | IC, REG, +5V, 500MA, 78M05CT |
| C46 | 24G382 | CAP, RLYTIC, 10UF, 16V, 20% |
| IC38 | 69G273 | IC, REG, 5V, .5A, 79M05 |
| C81,79,80 | 24G437 | CAP, RLYTIC, 470UF, 25V, +100/-20 |
| IC44,43 | 69G405 | IC, OP-AMP, LOW OFFSET, OP177 |
| IC49 | 69G404 | IC, CONV, D/A, 12BIT, MAX543 |
| IC45 | 69G113 | IC, COMP, SINGLE, 8 PIN, LM306 |
| IC52 | 69G189 | IC, OP-AMP, DUAL, BIFET, TL082 |
| CR27,26,24,25,28 | 16G10 | DIODE, SIL, 400V, 1A, 5UA, 1N4004 |
| R64 | 14A38-2403A | RES, MET.F, 2.4K, 1/4W, 1%, 100PP |
| R36 | 14A38-2054A | RES, MET.F, 20.5K, 1/4W, 1%, 100P |
| R66 | 14A38-4991A | RES, MET.F, 49.9, 1/4W, 1%, 100PP |
| R41 | 14A38-1824A | RES, MET.F, 18.2K, 1/4W, 1%, 100P |
| R23,22 | 14C26-1766A | RES, MET.F, 1.76M, 1/2W, .1%, 100 |
| R21,20 | 14A80-1357A | RES, MET.F, 13.5M, 1W, .1%, 100PP |
| C110 | 24G482 | CAP, MYLAR, .1UF, 50V, 5%, 5MM |
| IC42 | 69G171 | IC, REG, +2.5V, 2% REF, LM3368Z |
| C70 | 24G151 | CAP, DISC, 22PF, 500V, 5%, NPO |
| C52,55,56,54,104,58,48 | 24G483 | CAP, MYLAR, .01UF, 50V, 5%, 5MM |
| R39 | 15A36-1 | POT, VPC20T CERM, 1K, .10% |
| C44,47,45 | 24G382 | CAP, RLYTIC, 10UF, 16V, 20% |
| R42 | 15A36-5 | POT, VPC, 10K, 20T |
| R45,46 | 69G659 | DECADE VOLTAGE DIVIDER, 100-10M |
| C74 | 24G70 | CAP, DISC, 100PF, 500V, 5%, NPO |
| C98 | 24G324 | CAP, DISC, 12PF, 500V, 5%, NPO |
| C65,66,64,63 | 24G474 | CAP, TRIM, 5.1-50PF, 250V |
| IC46 | 69G135 | IC, REG, +12V, 500MA, 78M12 |
| L10,6 | 41G36 | RELAY, DPDT, 12V, DC COIL |
| C84,151 | 24G239 | CAP, LYTIC, 150UF, 200V, +100/-20 |
| C152 SEPARATE BIN, LONGER LEAD | 24G239 | CAP, LYTIC, 150UF, 200V, +100/-20 |
| C106,90 | 24G221 | CAP, DISC, .01UF, 3000V, +80/-20% |
| C92 | 24G138 | CAP, DISC, 6.8PF, 500V, 10%, NPO |
| C93 | 24G651 | CAP, DISC, 10PF, 3000V, 20% |
| IC40,39 | 69G267 | IC, NAND, 2-IN, 74HC00 |
| IC57 | 69G64-B | IC, SW, TRIPLE, 16 PIN, 4053B |
| IC47,48 BEVELED SIDE TO PIN 1 | 69G310 | IC, OPTOCOPLER, PS2501 |
| IC25 | 69G268 | IC, NAND, 2-IN, 74HC132 |
| CR22,23 | 16G10 | DIODE, SIL, 400V, IA, 5UA, 1N4004 |
| CR14,4,7,9,10,8 | 50C5-2:A | DIODE, SIL, 75V, 100MA, .25UA, 41 |
| R80 | 14C1-620 | RES, CARBON, 62, 1/4W, 5% |
| R38 | 14A38-1004A | RES, MET.F, 10K, 1/4W, 1%, 100PPM |
| R37 | 14A38-2004A | RES, MET.F, 20K, 1/4W, 1%, 100PPM |
| R47 | 14C26-1007A | RES, MET.F, 10M, 1/2W, .1%, 100PP |

Schematic References**Component****Part Description**

| | | |
|--------------------------------|----------|--|
| C75,82,76 | 24G37 | CAP, RLYTIC, 470UF, 25V, +100/-20 |
| L5 | 46G92 | IND, WIREFORM, 50UH, 1.5A |
| C109,112 | 24G482 | CAP, MYLAR, .1UF, 50V, 5%, 5MM |
| IC34 | 69G70 | IC, REG, +5V, 500MA, 78M05CT |
| C32,57,53,105,51 | 24G483 | CAP, MYLAR, .01UF, 50V, 5%, 5MM |
| C69 | 24G208 | CAP, DISC, 150PF, 500V, 10%, 25F |
| TR13,11,10 | 19A33-1 | TRANS, NPN, 40V, 200MA, 2N3904 |
| TR12 | 19A31-1 | TRANS, N-CHNL, 50V, 50MA, 2N3958 |
| C37,95,94 | 24G382 | CAP, RLYTIC, 10UF, 16V, 20% |
| C42,73 | 24G368 | CAP, DIS, .001UF, 100V, 10% |
| C43 | 24G496 | CAP, MYLAR, .47UF, 50V, 10%, BULK |
| CR12,11 USE 3/8" SPAG. ON 2 LE | 50G24 | DIODE, SIL, 35V, 50MA, 20PA, PAD |
| IC35 | 69G6-B | IC, COUNTER, 12-STGE, 16PIN, 4040 |
| C71 | 24G512 | CAP, MET.POLY, .1UF, 250V, 10%, B |
| IC36 | 69G244 | IC, NOR, 2-IN, 74HC02 |
| C108 | 24G214 | CAP, DISC, .001UF, 500V, 10%, 25F |
| IC9 | 69G302 | IC, F-FLOP, D, TRI-STATE, 74HC374 |
| L9,8,7 | 41G36 | RELAY, DPDT, 12V DC COIL |
| C150 | 24G75 | CAP, DISC, 27PF, 500V, 5%, MPO |
| IC20,18,19,21 | 69G324 | IC, OR, 2-IN, 74HC32 |
| IC28 | 69G322 | IC, MICRO, 80C31 |
| IC23 | 69G202 | IC, F-FLOP, "D", OCTAL, 74HC373 |
| IC22 | 69G249 | IC, OR, 3-3IN, 74HC4075 |
| IC26 | 69Z615 | IC, STATIC RAM, 100NS, CMOS |
| IC59 | 69G268 | IC, NAND, 2-IN, 74HC132 |
| IC30 | 69G63 | IC, OP-AMP, SINGLE, BIFET, TL081 |
| IC58 | 69G172 | IC, RES, NET, 5X10K, 6PIN, SIP PK |
| CR3,5,37,103,104 | 50C5-2:A | DIODE, SIL, 75V, 100MA, .25UA, 41 |
| CR46 | 50C4-6:A | DIODE, ZENER, 6.2V, 100MA, 5%, 47 |
| CR105 | 50C4-4 | DIODE, ZENER, 2.4V, 100MA, 1N5221 |
| IC32 | 69G116 | IC, REG, -5V, 100MA, 79L05 |
| C29,30,31,19,7,20,21 | 24G483 | CAP, MYLAR, .01UF, 50V, 5%, 5MM |
| C34,35,36 | 24G382 | CAP, RLYTIC, 10UF, 16V, 20% |
| C86 | 24G424 | CAP, RLYTIC, 2200UF, 35V, 20% |
| C40 WITH 3/8" SPAG. | 24G345 | CAP, POLY, .0022UF, 160V, 10% |
| C39 | 24G403 | CAP, POLYPROP, .01UF, 400V, 10% |
| TR1,2,3 | 19G96 | TRANS, N-CHNL, 60V, 2A, MPF960 |
| X1 | 47G57 | CRYSTAL, 12MHZ, MICRO |
| C26,25 | 24G75 | CAP, DISC, 27PF, 500V, 5%, NPO |
| IC11,1,2,7,5,6,3,4 | 69G302 | IC, F-FLOP, D, TRI-STATE, 74HC374 |
| IC50 | 69G238 | IC, RES NET, PULLUP, 8 X 100K |
| IC31,51 | 69G347 | IC, BUFFER, OCTAL, 74HC244 |
| CR1,2,112,107,113,106,110,109, | 50C5-2:A | DIODE, SIL, 75V, 100MA, .25UA, 41 |
| CR45 | 50C4-6:A | DIODE, ZENER, 6.2V, 100MA, 5%, 47 |
| C38 | 24G404 | CAP, POLYPROP, .033UF, 200V, 10% |
| C41 WITH 3/8" SPAG. | 24G262 | CAP, POLY, 150PF, 125V, 5% |
| TR8 | 19A34-1 | TRANS, PNP, 40V, 200MA, 2N3906 |
| TR7 | 19A30-1 | TRANS, PNP, 40V, 3A, MJE170 |
| TR4,6,5 | 19A33-1 | TRANS, NPN, 40V, 200MA, 2N3904 |
| TR9 | 19G50 | TRANS, N-CHNL, 25V, 10MA, J211 |
| C27,15,12,4,5,1,16,2,6,10 | 24G483 | CAP, MYLAR, .01UF, 50V, 5%, 5MM |
| R12 | 15C26-20 | POT, MVPC CERM, 5K, 1/2W, 20% |
| R11 | 15C26-19 | POT, MVPC CERM, 50K, 1/2W, 20% |
| FOR B1 | 17Z14 | HOLDER, BATTERY COIN |
| CR102 | 50C5-2:a | DIODE, SIL, 75V, 100 mA, .25 μ A, 4148 |

1000 CONTROL/DVM/POWER SUPPLY BOARD - LEGEND

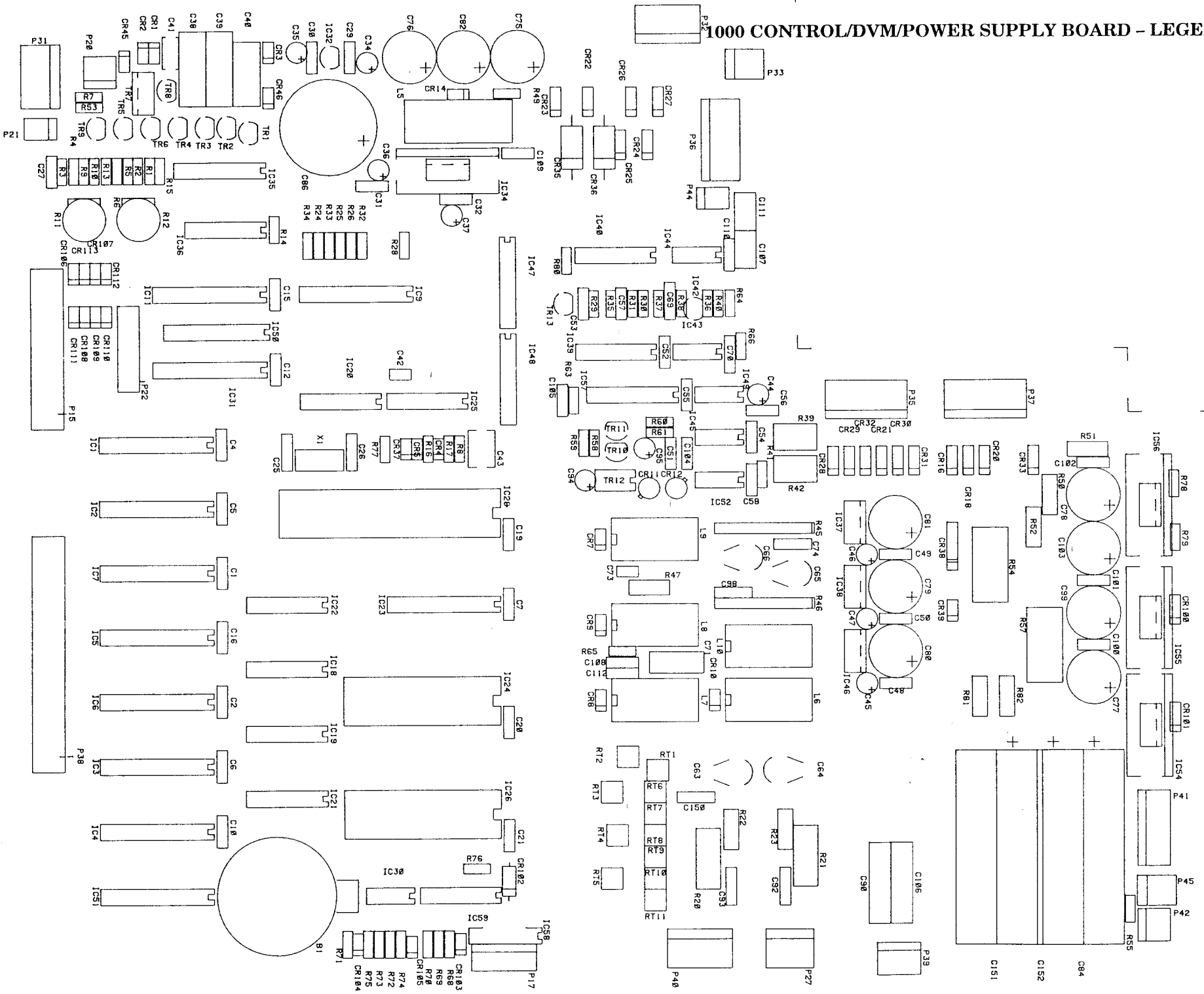

Schematic References
2000 Video Board

Component

Part Description

| | | |
|---------------------------------|--------------|----------------------------------|
| IC49,50 | 69G518 | IC, EPROM, 32KX8, 150NS, |
| IC102,68,69,71,70 | 69G330 | IC, BUFFER, PWR AMP, EL2003 |
| R215 | 14G102-1001A | RES, CHIP, 10, 1/8W, 1%, 100PPM |
| R3,5,51,75 | 14G102-1002A | RES, CHIP, 100, 1/8W, 1%, 100PPM |
| R4,6-9,12-14,48-50,68,136-139 | 14G102-1003A | RES, CHIP, 1K, 1/8W, 1%, 10PPM |
| 176-179,180-182,185,210 | | |
| R24,29,133 | 14G102-1004A | RES, CHIP, 10K, 1/8W, 1%, 100PPM |
| R32 | 14G102-1006A | RES, CHIP, 1M, 1/8W, 1%, 100PPM |
| R33 | 14G102-1007E | RES, CHIP, 10M, 1/8W, 1%, 500PPM |
| R144,183,184,192-199 | 14G102-1102A | RES, CHIP, 110, 1/8W, 1%, 100PPM |
| R10,70 | 14G102-1212A | RES, CHIP, 121, 1/8W, 1%, 100PPM |
| R37,38,39 | 14G102-1213A | RES, CHIP, 1.21K, 1/8W, 1%, 100P |
| R34,35,36,201 | 14G102-1502A | RES, CHIP, 150, 1/8W, 1%, 100PPM |
| R1 | 14G102-1503A | RES, CHIP, 1.5K, 1/8W, 1%, 100PP |
| R80-95,165,167,168,206-209 | 14G102-1822A | RES, CHIP, 182, 1/8W, 1%, 100PPM |
| R69 | 14G102-1823A | RES, CHIP, 1.82K, 1/8W, 1%, 100P |
| R220 | 14G102-2002A | RES, CHIP, 200, 1/8W, 1%, 100PPM |
| R15 | 14G102-2003A | RES, CHIP, 2K, 1/8W, 1%, 100PPM |
| R73 | 14G102-2432A | RES, CHIP, 243, 1/8W, 1%, 100PPM |
| R40,41,112-127,140,141,143,14 | 14G102-3012A | RES, CHIP, 301, 1/8W, 1%, 100PPM |
| 147-164,166,200,202-205,212,213 | | |
| R71 | 14G102-3013A | RES, CHIP, 3.01K, 1/8W, 1%, 100P |
| R57 | 14G102-4321A | RES, CHIP, 43.2, 1/8W, 1%, 100PP |
| R16,17,67 | 14G102-5112A | RES, CHIP, 511, 1/8W, 1%, 100PPM |
| R28 | 14G102-5113A | RES, CHIP, 5.11K, 1/8W, 1%, 100P |
| R186,216 | 14G102-6811A | RES, CHIP, 68.1, 1/8W, 1%, 100PP |
| R27 | 14G102-6813A | RES, CHIP, 6.81K, 1/8W, 1%, 100P |
| R2,96-111,128,130-132,187-190 | 14G102-8252A | RES, CHIP, 825, 1/8W, 1%, 100PPM |
| R74 | 15G50-101 | SMT, POT, VPC CERM, 100, .2W, 30 |
| R26 | 15G50-103 | SMT POT, VPC CERM, 10K, .2W, 30% |
| R45-47,72,76-79 | 15G50-152 | SMT POT, VPC CERM, 1.5K, .2W, 30 |
| R25 | 15G50-681 | SMT POT, VPC CERM, 680, 2W, 30% |
| R19 | 15G50-682 | SMT POT, VPC CERM, 6.8K, .2W, 30 |
| CR18,27-40 | 16G35 | DIODE, SMT, SIL, 400V, 1A, 4004 |
| TR4,7 | 19G92 | SMT TRANSISTOR, NPN, 3904, SOT23 |
| TR5,6,9,10 | 19G95 | SMT TRANS, PNP, 40V, 200MA, 3906 |
| TR8 | 19G102 | SMT TRANS, PNP, 15V, 25MA, BFT92 |
| C1-8,11-18,23-26,38-52,80-83 | 24G465 | CAP, CHIP, .01UF, 50V, 10%, X7R |
| 89,92,93,96-99,100,101,102-111 | | |
| C9,10,58,62,65,85,87,88,90,91 | 24G575 | CAP, CHIP, .1UF, 50V, 10%, X7R |
| C113-123 | 24G594 | CAP, CHIP, 1500PF, 50V, 10%, X7R |
| C21,55,56,57 | 24G606 | CAP, CHIP, .001UF, 50V, 10%, X7R |
| C20,27,84,86 | 24G612 | CAP, CHIP, 100PF, 50V, 5%, NPO |
| C22 | 24G616 | CAP, CHIP, 22PF, 50V, 5%, NPO |
| CR4,5,6,7,10 | 50G36 | SMT DIODE, SIL 75V, 100MA, 4148 |
| IC39 | 69G428 | SMTIC, CONV, 8BIT, DAC-08E |
| IC43,105 | 69G431 | SMTIC, MUX, 16PIN, 4052 |
| IC20,27 | 69G435 | SMTIC, NOR, 2-IN, 74HC02 |
| IC13 | 69G438 | SMTIC, NAND, 2-IN, 74HC00 |
| IC19 | 69G439 | SMTIC, NAND, 2-IN, 74HC132 |
| IC40 | 69G440 | SMTIC, COUNTER, BINARY, 74HC393 |
| IC1,2,10,16-18,74,86,87 | 69G441 | SMTIC, F-FLOP, TRI-S, D, 74HC374 |
| IC14,28,83,95 | 69G443 | SMTIC, OR, 2-IN, 74HC32 |
| IC5 | 69G453 | SMTIC, OP-AMP, QUAD, TL084 |
| IC37,98 | 69G454 | SMTIC, F-FLOP, D, DUAL, 74AC74 |
| IC15,21,66,84 | 69G455 | SMTIC, AND, 2-IN, 74HC08 |
| IC97 | 69G456 | SMTIC, SW, ANA, 74HC4316 |
| IC38 | 69G458 | SMTIC, OP-AMP, HI-SPEED, 6361 |
| IC29 | 69G465 | SMTIC, INV, HI-SP, 74HC04 |
| IC96,106 | 69G498 | SMTIC, NOR, 2-IN, ECL, 10H102 |
| IC32,33,34,35,101 | 69G512 | SMTIC, COUNTER, 4BIT, 74ACT161 |
| IC48,77,79,100 | 69G513 | SMTIC, MUX, 10F8, 74ACT151 |
| IC11,12,25 | 69G515 | SMTIC, AND, 2-IN, 74HCT08 |

Schematic References**Component****Part Description**

| | | |
|---------------------------------------|----------|-----------------------------------|
| IC6,7 | 69G516 | SMTIC, LATCH, OCTAL, 74HCT373 |
| IC8,9 | 69G517 | SMTIC, TRNSCVR, OCTAL, 74HCT245 |
| IC47 | 69G519 | SMTIC, PROCESSOR, GRAPHICS, 3401 |
| IC67 | 69G537 | SMTIC, MUX, 2-IN, 74ACT157 |
| IC76 | 69G539 | SMTIC, AND DRIVER, 2-IN, 74AS100 |
| IC85 | 69G553 | SMTIC, NAND, 2-IN, 74ACT00 |
| IC3,24,26 | 69G613 | SMTIC, AND GATE, 2 INPUT, 74ACT0 |
| IC23,73,22 | 69G756 | SMTIC, QUAD, 2 IN, EX.OR, 74ACT8 |
| IC59,60,61,62 | 69G826 | SMTIC, VRAM, 256KX4, 42C4256 |
| IC63 | 69G837 | SMTIC, HEX COUNTER, 10H136, PLCC |
| IC72 | 69G838 | SMTIC, QUAD 2INPUT AND, MC10H104 |
| IC64,65 | 69G839 | SMTIC, 8BIT SHIFT REG, 100341 |
| IC44 | 69G840 | SMTIC, PROG FREQ GEN, AV9110 |
| IC103 | 69G886 | SMTIC, QUAD, LOWPWR, AMP, EL2444 |
| IC108 | 69G916 | SMTIC, DUAL D F-FLOP, MC10H131 |
| IC107 | 69G917 | SMTIC, EXCL OR/NOR, MC10H107 |
| IC36,45 | 69G920 | SMTIC, 4BIT SYNC CNTR, 74FCT163 |
| IC75 | 69G542 | IC, COLOR PALETTE, ADV476 |
| IC109,110,111 | 69G330 | IC, BUFFER, PWR AMP, EL2003 |
| IC54,53,52,51 | 69G525 | IC, DRAM, 64K X 4, 4067C-10 |
| C68 | 24G407 | CAP, RLYTIC, 47UF, 25V, +/- 20% |
| IC104 | 69G70 | IC, REG, +5V, 500MA, 78M05CT |
| IC99 | 69G116 | IC, REG, -5V, 100MA, 78L05 |
| L4 | 41G37 | RELAY, 4PDT, 12V |
| IC78,46 | 69G29 | IC, REGC +5V, 100MA, 78L05 |
| C124,66,64,53,37,59,61,60 | 34G382 | CAP, RLYTIC, 10UF, 16V, 20% |
| TR1,2,3,4,7,5,6 | 33G361 | PTC, 250V, 3A |
| R219,217,218 | 14C4-330 | RES,CARBON, 33, 1/2W, 5% |
| CR20,19,22,21,24,23,25,26,43,46,41,42 | 50C4-22 | DIODE, ZENER, 6.2V, 765MA, 10% |
| X1 SQUARE CORNER CLOSE TO C15 | 69G527 | IC, OSC, CLOCK, TTL, 40 MHZ |
| X2 | 47G57 | CRYSTAL, 12 MHZ, MICRO |
| C69 | 24G496 | CAP, MYLAR, .47UF, 50V, 10%, BULK |
| IC41 | 69G260 | IC, REG, +12V, 1A, TO-220, 7812 |
| IC42 | 69G511 | IC, REG, -12V, 1A, 7912 |

6000 EMI Filter Board
(6000 Board See Block Diagram)

Schematic References**Component****Part Description**

| | | |
|------|----------|------------------------------------|
| R1,2 | 14C4-266 | RES, CARBON, 22M, 1/2W, 5% |
| L1,2 | 46G92 | INC, WIREFORM, 50μH, 1.5A |
| C1,2 | 25G686 | AP, DISC, 2200pF, 125VAC, 20%, CSA |

Miscellaneous Chassis Parts**Schematic References****Component****Part Description**

| | | |
|------|---------|--------------------------------|
| NONE | 128A151 | TRANSFORMER ASSEMBLY |
| NONE | 68G277 | IC, REG, +5V, 1A, 7805CT |
| NONE | 126G18 | DIN JACK ASSEMBLY |
| NONE | 64G1433 | FUSEHOLDER, SQ, SNAP-IN, GRAY |
| NONE | 44G20 | FUSE, FASTBLOW 3AG, 1AMP, 250V |
| NONE | 44G18 | FUSE, FASTBLOW 3AG. 1/2A, 250V |

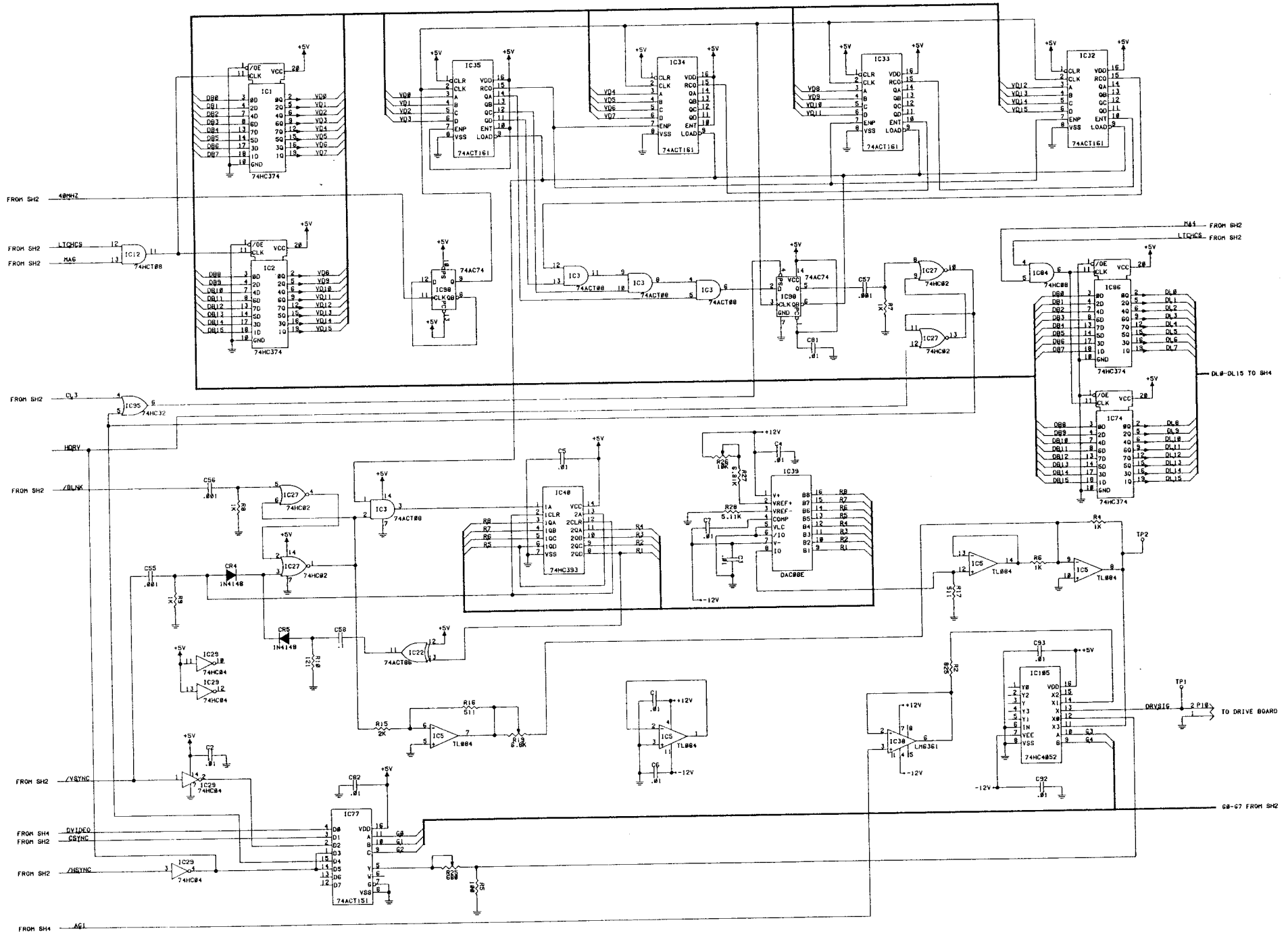

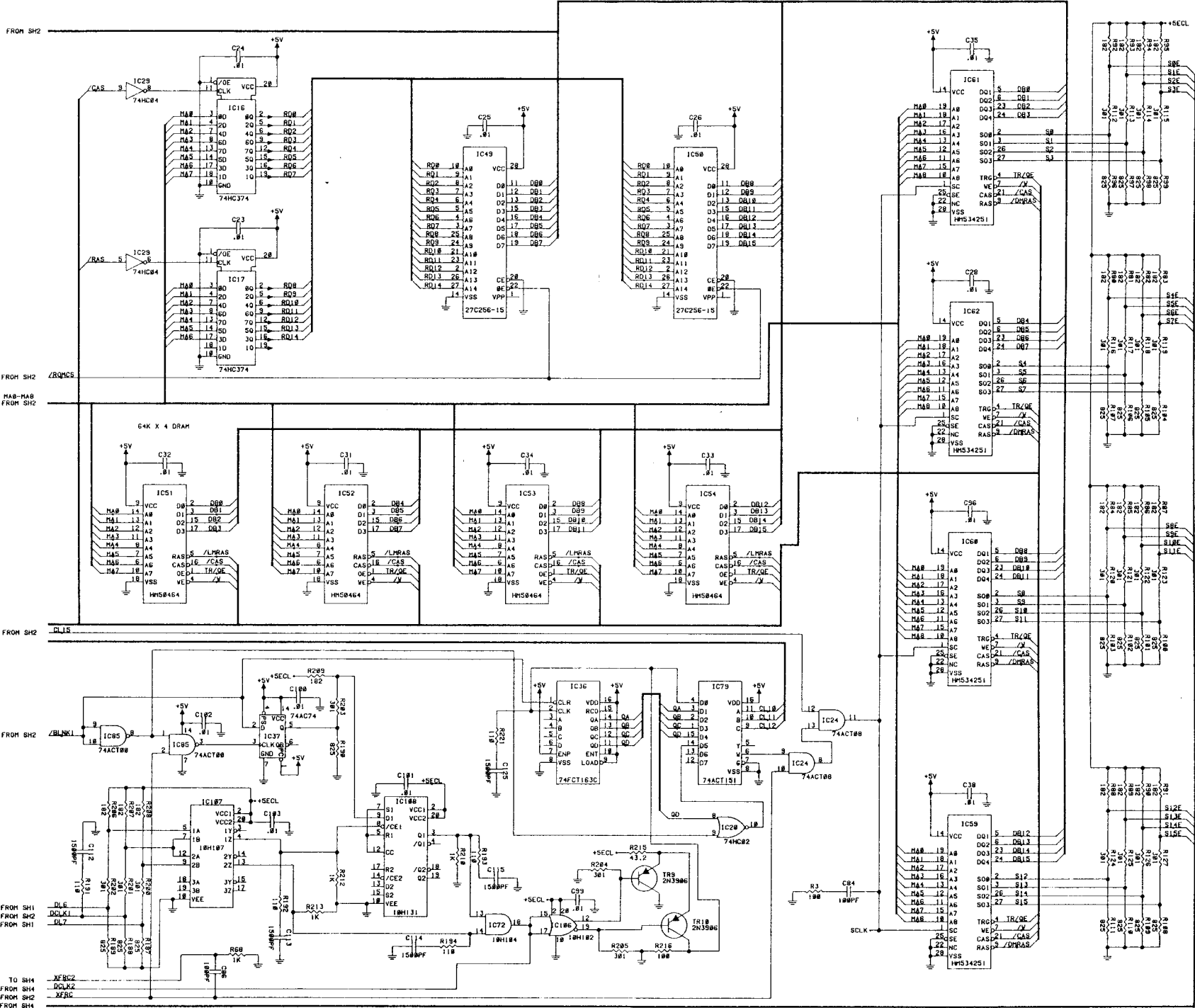

2000 VIDEO BOARD LEGEND

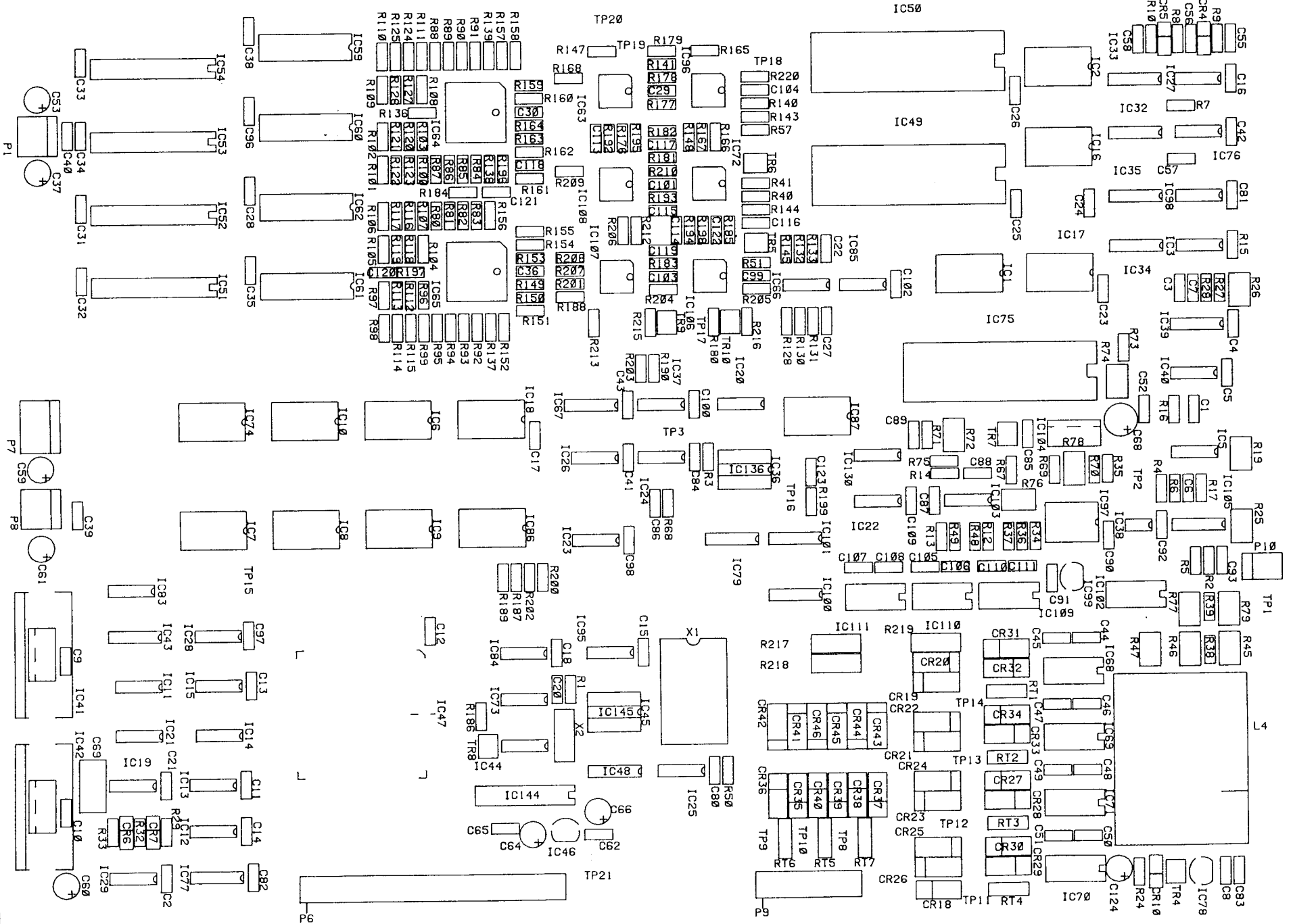

Schematic References
3000 Front Panel Board

Component

Part Description

| | | |
|---------------------|---------|----------------------------------|
| D1 | 23A98 | LCD, DIGITAL, CM2125 |
| SW1,2,4,5 | 25G358 | SWITCH, ROTARY, 1 POLE, 12 POS. |
| IC3 | 69G196 | SMTIC, DRIVER IC, 52 PIN, UPD722 |
| D2 | 23A108 | LCD, SCAN/PIX, CM2125 |
| IC6 | 69G64-B | IC, SW, TRIPLE, 16PIN, 40538 |
| IC5,4,8 | 69G407 | IC, SH REG, PAR/SER, 74HC165 |
| C5,1,6,2,11,12,13,3 | 24G483 | CAP, MYLAR, .01UF, 50V, 5%, 5MM |
| IC2,7,1 | 69G238 | IC, RES NET, PULLUP, 8 X 100K |
| TR2 | 19A44 | TRANS, NPN, 40V, 600MA, 2N4401 |
| C8 | 24G485 | CAP, MYLAR, .047UF, 50V, 10%, BU |
| C9 | 24G382 | CAP, RLYTIC, 10UF, 16V, 20% |
| T2 | 28G126 | TRANSFORMER, EL BACKLIGHT |
| C14 | 24G248 | CAP, RLYTIC, 330UF, 10V, 20% |
| R14 | 15A42-7 | POT, MVPC, 500, 20%, TOP-BOT ADJ |
| CR5 | 20G20 | LAMP, LED, 5V, 20MA, FLASHING |

3000 Front Panel Legend

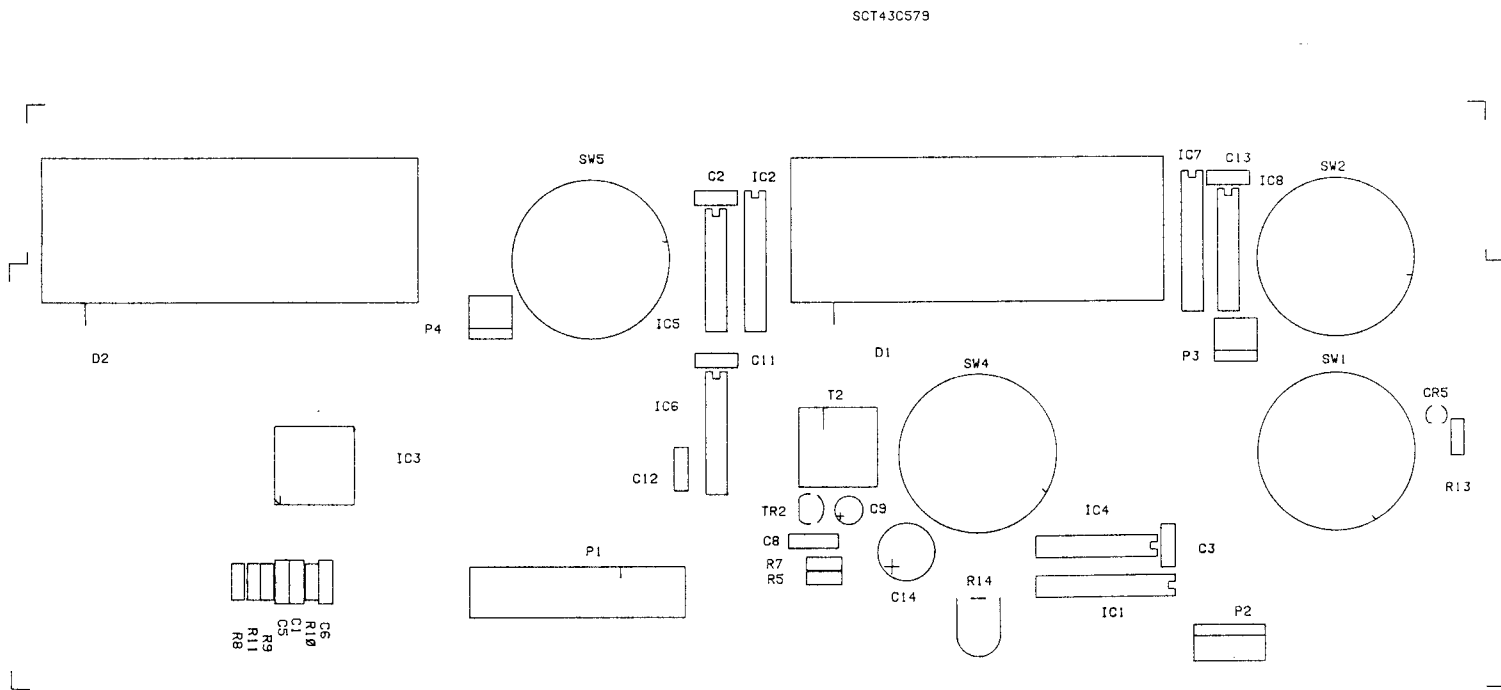

Schematic References

4000 Keyboard Board

R1,2,3,4,5,6,7,8,9,10,11,12,
CR5,6,7,8,9,10,11,12,13,14,15

Component

14G102-4752A
20G55

Part Description

RES, CHIP, 475, 1/8W, 1%, 100PPM
SMTLED, RED, 1.8V, 10MA

4000 Keyboard Legend (Front)

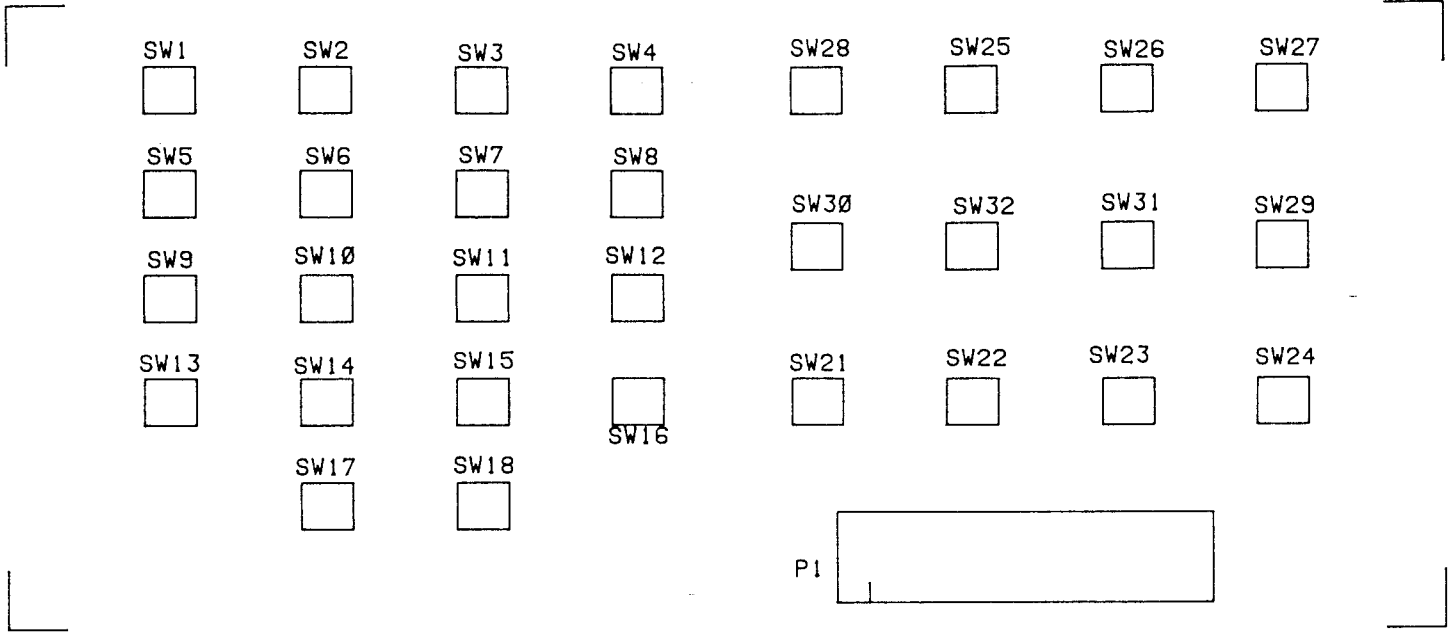

4000 Keyboard Legend (Back)

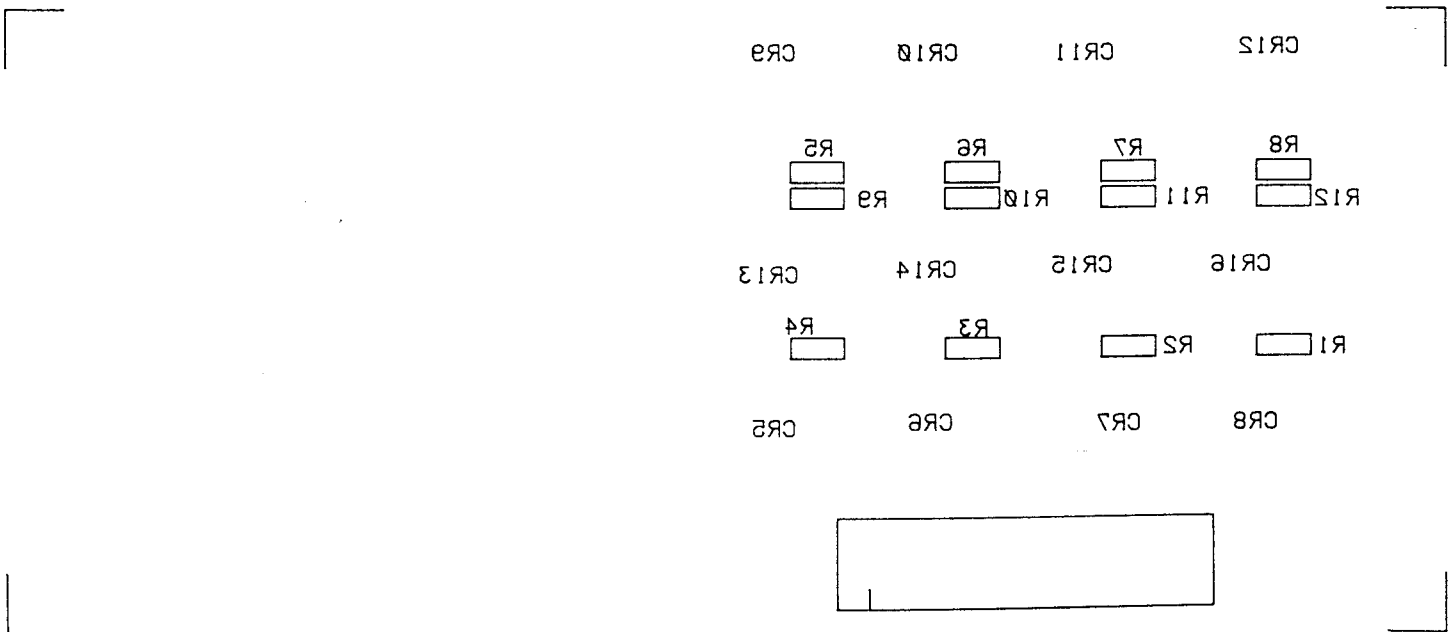

4000 SOFTKEY BOARD - SHEET 1

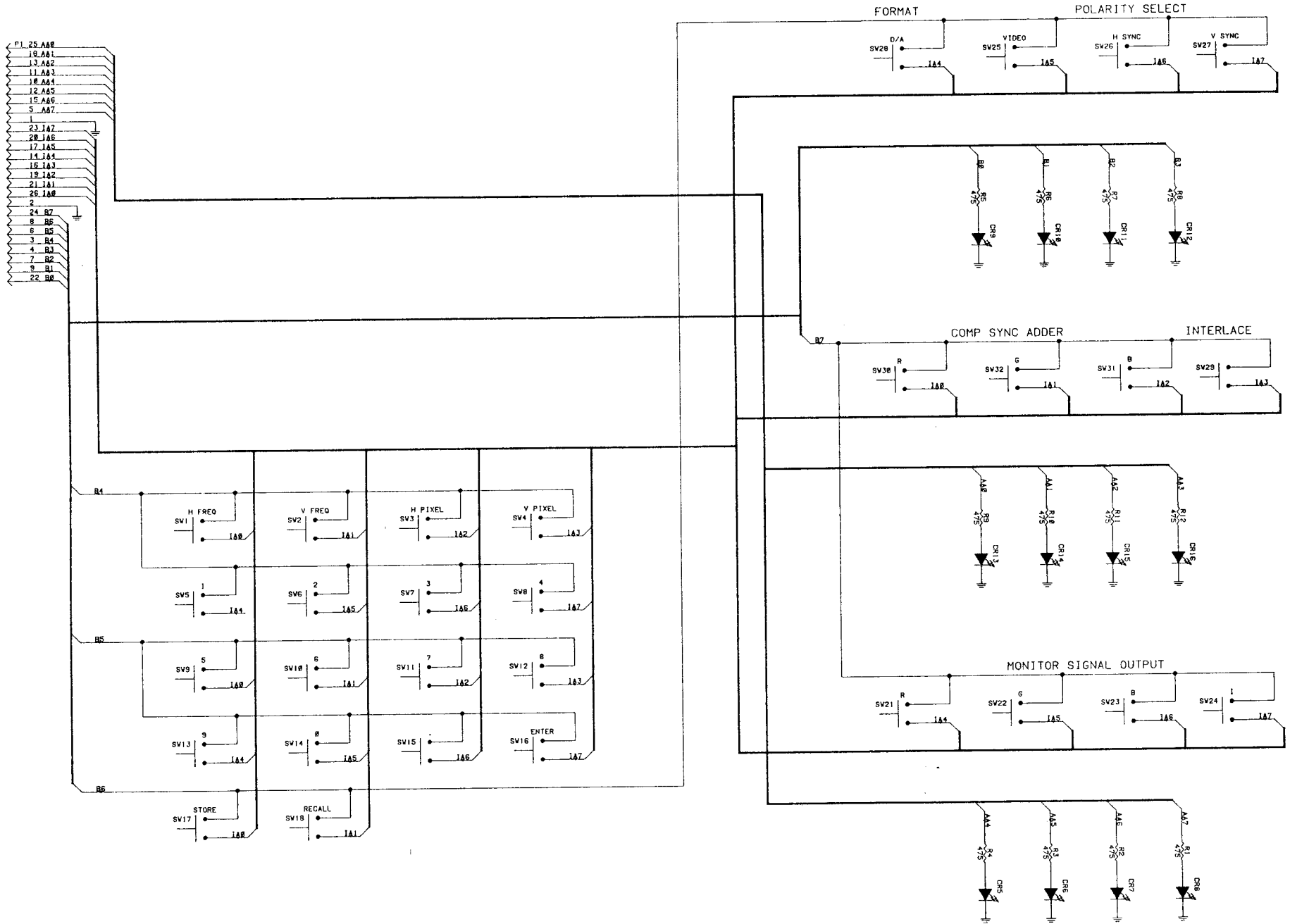

TO MAIN

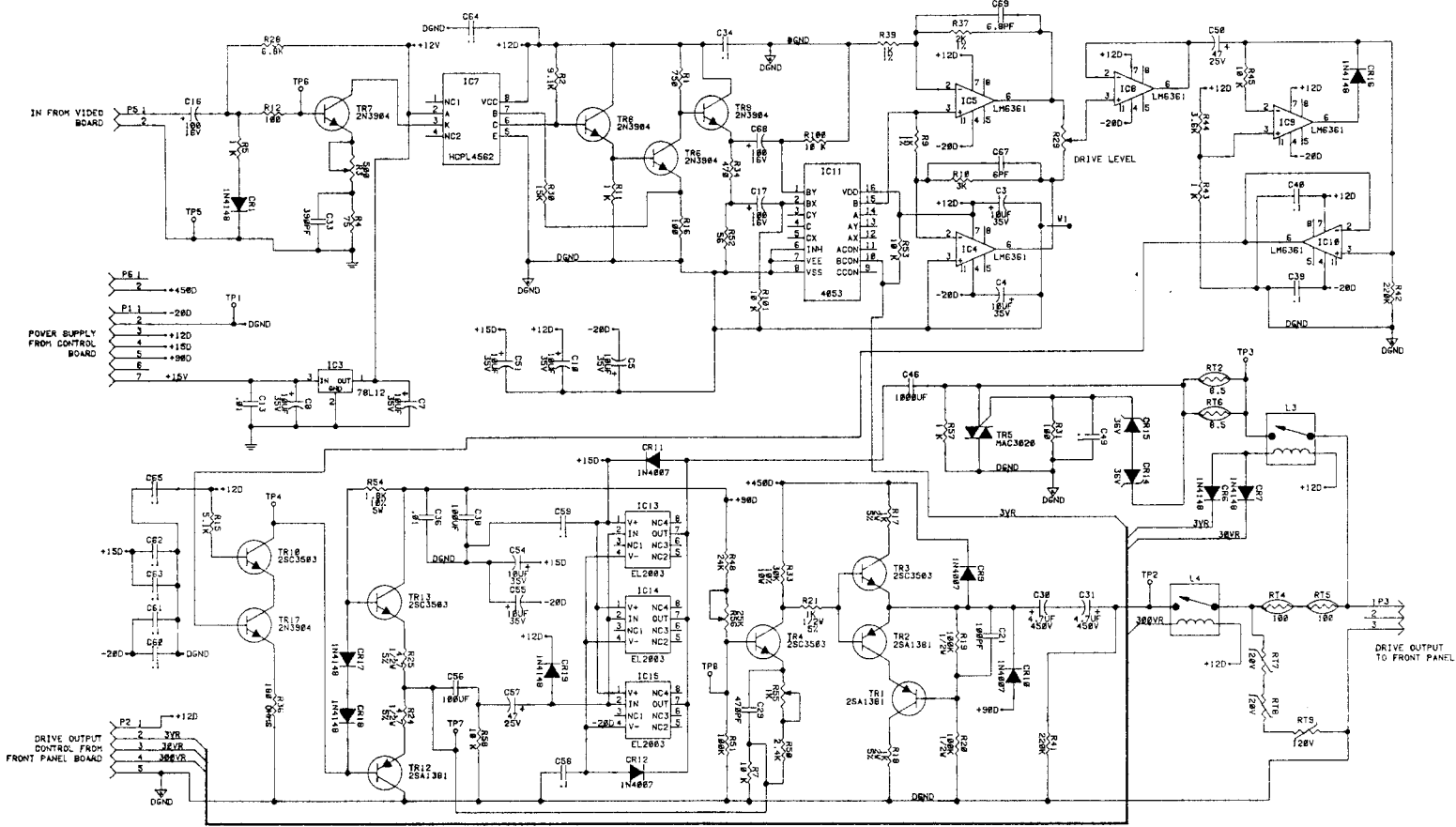

Schematic References
5000 Drive Board

Component

Part Description

TR1,2,12 SUB-ASSEMBLY
 TR3,4,13 SUB-ASSEMBLY
 C46 SUB-ASSEMBLY
 R29 SUB-ASSEMBLY
 CR25 ADD-ON
 SUB-ASSEMBLY
 R54 INSTALL AND CLIP LEADS
 R33 INSTALL AND CLIP LEADS
 RT9,8,7 INSTALL AND CLIP LEAD
 RT5,4 INSTALL AND CLIP LEADS
 RT6,2 INSTALL AND CLIP LEADS
 IC7
 CR1
 CR9
 R19,20
 R21
 C21
 C13
 IC3

19G107
 19G110
 24G631
 15B56
 50C5-2:A
 19A29-3
 14A94-5
 14G105-1
 33G273
 33G285
 33G333
 69G412
 50C5-2:A
 16G18
 14C4-104
 14C4-102
 24G70
 24G483
 69G127

TRANS, PNP, 300V, 7W, 2SA1381
 TRANS, NPN, 300V, 7W, 2SC3503
 CAP, RLYTIC, 1000UF, 63V, 20%, N
 POT, HPC CARB, 10K, 1/2W, 30%
 DIODE, SIL, 75V, 100MA, .25UA, 4
 TRANS, NPN, 80V, 3A, MJE182
 RES, W/W, 1.8K, 5W, 5%
 RES, W/W, 30K, 10W, 5%
 MOV, 120V, 10%
 THERMISTOR, 100-OHM, @25 DEG. C
 THERMISTOR, 8.5 OHM, 600V
 IC, OPTOCOUPLER, HCPL-4562
 DIODE, SIL, 75V, 100MA, .25UA, 4
 DIODE, SILICON, 1KV, 1A, 10UA, 4
 RES, CARBON, 100K, 1/2W, 5%
 RES, CARBON, 1K, 1/2W, 5%
 CAP, DISC, 100PF, 500V, 5%, NPO
 CAP, MYLAR, .01UF, 50V, 5%, 5MM
 IC, REG, +12V, 100mA, 78L12

C8,7,51,10,5
 C16
 R3
 C33
 TR7
 L4
 L3
 C31,30
 IC13,14,15
 R17,18
 CR11,12,10
 CR14,15
 CR17
 TR6,9,8
 C68
 TR5
 C64,49,63,61,62,60,59
 C54
 C57
 R55
 C29
 R56
 C38,56 CLIP 1/8" PAST THE BOD
 IC11
 IC5,4,9,10,8
 R39,9
 R37
 CR6,7,19,16,18
 C36
 C4,3,55 - CUT NOT CRIMPED
 C34,58,40,65,39

 C69
 C17
 C67
 C50
 TR17
 TR10

24G448
 24G442
 15C26-3
 24G464
 19A33-1
 41G35
 41G39
 24G430
 69G330
 14C10-102
 16G18
 50C4-10
 50C5-2:A
 19A33-1
 24G442
 50G26
 24G482
 24G448
 24G407
 15C26-15
 24G119
 15C26-26
 24G498
 69G64-B
 69G401
 14A38-1003A
 14A38-2003A
 50C5-2:A
 24G126
 24G448
 24G482

 24G138
 24G442
 24G154
 24G407
 19A33-1
 19G110

CAP, RLYTIC, 10UF, 35V, +/- 205
 CAP, RLYTIC, 100UF, 16V, +/- 20%
 POT, MVPC CERM, 500, 1/2W, 20%
 CAP, DISC, 120PF, 500V, 5%, NPO
 TRANS, NPN, 40V, 200MA, 2N3904
 RELAY, REED, HE3321A1200
 RELAY REED, 712-12
 CAP, RLYTIC, 4.7UF, 450V, +/- 20
 IC, BUFFER, PWR AMP, EL2003
 RES, CARBON, 1K, 2W, 5%
 DIODE, SILICON, 1KV, 1A, 10UA, 4
 DIODE, ZENER, 36V, 30MA, 10%, 47
 DIODE, SIL, 75V, 100MA, .25UA, 4
 TRANS, NPN, 40V, 200MA, 2N3904
 CAP, RLYTIC, 100UF, 16V, +/- 20%
 TRIAC, 25A, 400V, 3020-25
 CAP, MYLAR, .1UF, 50V, 5%, 5MM
 CAP, RLYTIC, 10UF, 35V, +/- 20%
 CAP, RLYTIC, 47UF, 25V, +/- 20%
 POT, MVPC CERM, 1K, 1/2W, 20%
 CAP, DISC, 470PF, 500V, 10%
 POT, MVPC CERM, 25K, 1/2W, 20%
 CAP, RLYTIC, 100UF, 100V, N-POLA
 IC, SW, TRIPLE, 16 PIN, 40538
 IC, OP-AMP, HI-SPEED, LM6361
 RES, MET.F, 1K, 1/4W, 1%, 100PPM
 RES, MET.F, 2K, 1/4W, 1%, 100PPM
 DIODE, SIL, 75V, 100MA, .25UA, 4
 CAP, DISC, .01UF, 200V, 20%, Z5U
 CAP, RLYTIC, 10UF, 35V, +/- 20%
 CAP, MYLAR, .1UF, 50V, 5%, 5MM
 C65 THE LEGEND IS UPSIDE DOWN
 CAP, DISC, 6.8PF, 500V, 10%, NPO
 CAP, RLYTIC, 100UF, 16V, +/- 20%
 CAP, DISC, 6PF, 500V, +/- .5PF,
 CAP, RLYTIC, 47UF, 25V, +/- 20%
 TRANS, NPN, 40V, 200MA, 2N3904
 TRANS, NPN, 300V, 72, 2SC350

5000 Drive Board Legend

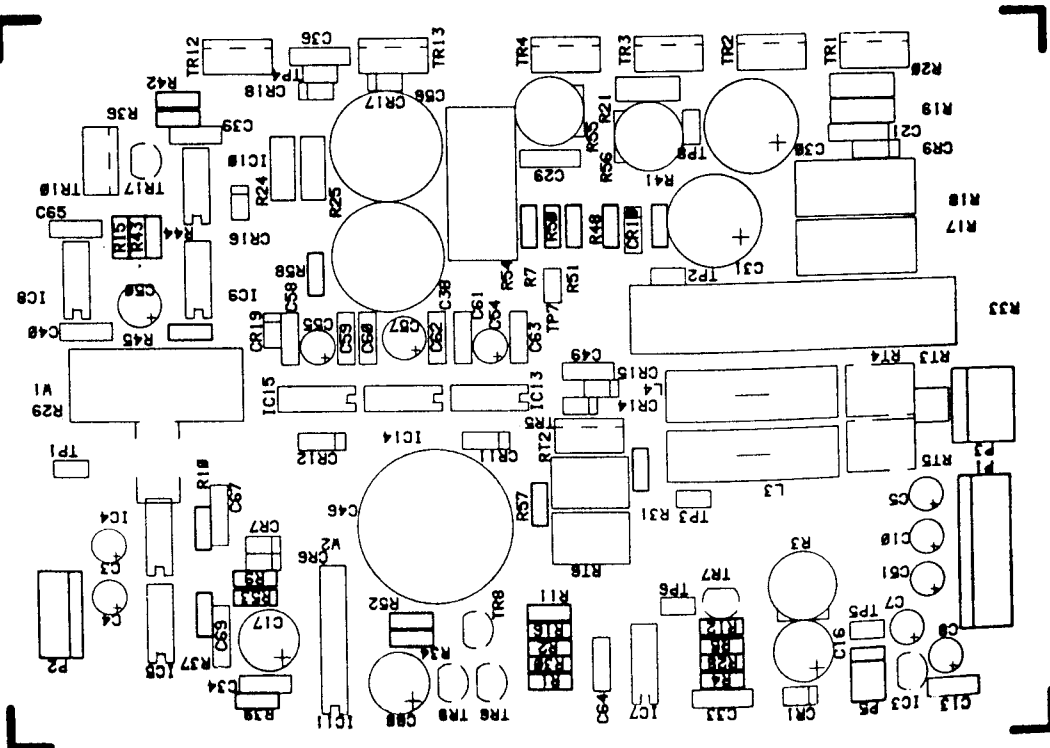

Computer Monitor Analyzer CM2125 Block Diagram

