

# PR570

## Powerite II™

### Variable Isolation Transformer & Safety Analyzer

#### Operation Manual

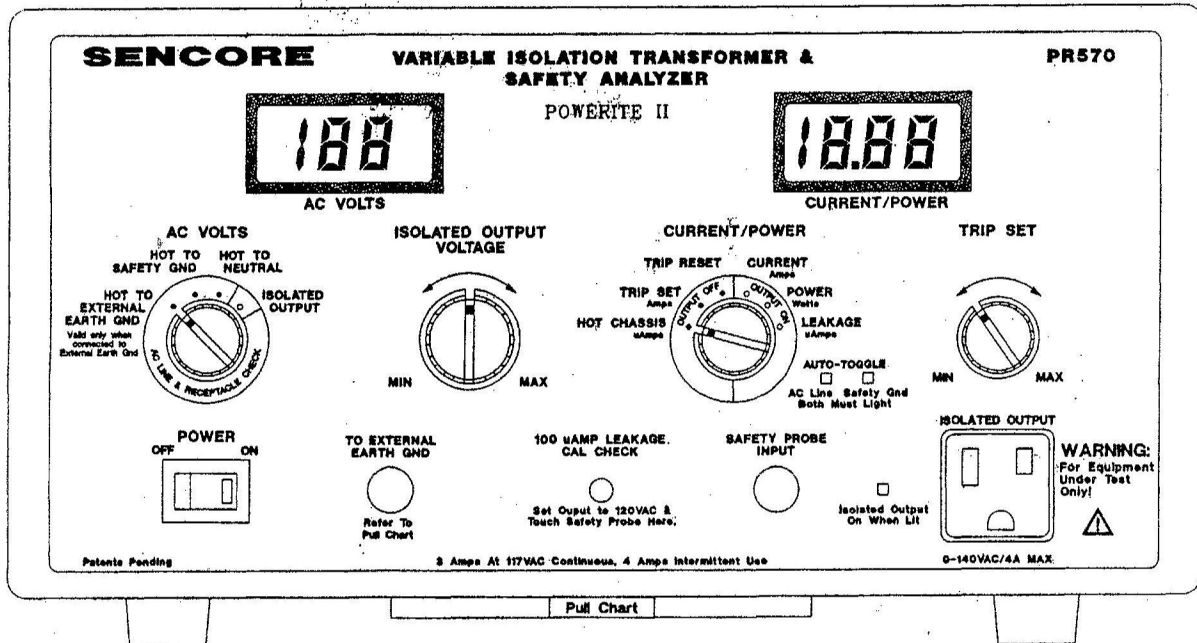

# SENCORE

3200 Sencore Drive, Sioux Falls, South Dakota 57107

# PR570

## Powerite II™

### Variable Isolation Transformer & Safety Analyzer

#### Operation Manual

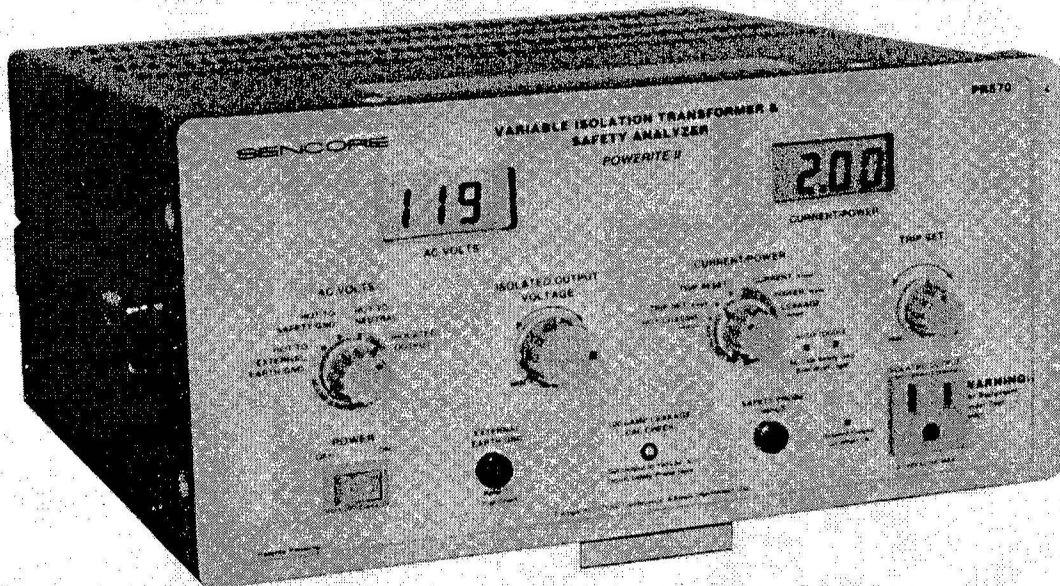

# SENCORE

# TABLE OF CONTENTS

**SAFETY PRECAUTIONS** .....Inside Front Cover

## **DESCRIPTION**

Introduction.....	1
Features.....	2
Specifications .....	3
Supplied Accessories.....	4
Controls .....	5

## **OPERATION**

Introduction.....	8
Power Connection .....	8
Fuse Replacement.....	8
AC Volts Functions.....	9
Hot To External Earth Gnd Check. ....	9
Hot To Safety Gnd Check .....	9
Hot To Neutral Check.....	10
Isolated Output Voltage Adjustment .....	10
Current/Power Functions.....	12
Hot Chassis Test .....	12
Current Trip Set.....	12
Current Trip Reset.....	13
Isolated Output Current Measurement.....	13
Isolated Output Power Measurement.....	14
Leakage Test.....	15

**SERVICE AND WARRANTY** .....Inside Back Cover

# DESCRIPTION

## INTRODUCTION

---

Many electronic devices which operate from the AC line do not have an internal AC line isolation transformer. Some of these devices have one side of the AC line connected directly to their chassis or main circuit reference bus while others use a full-wave bridge rectifier with the output reference connected to the chassis. This places the chassis at one-half the line voltage potential with reference to earth ground no matter how the line cord is connected to the AC line. Devices which use a switch mode power supply have an isolated main chassis, but the circuits within the power supply use a "hot" ground which is not isolated from the AC line. All these devices must be isolated from the AC line with an isolation transformer during service to prevent shock hazards and to prevent the possibility of damaging the device under test or test equipment connected directly to the chassis or "hot" ground.

Often when servicing, especially away from the shop, you may wonder whether an improperly wired AC receptacle is causing operation problems. Wrong line voltage also causes improper operation in some devices, which may appear as though the device under test is defective.

Many circuit troubleshooting procedures require that the AC line voltage be adjustable to test regulators, shut-down circuits, and other voltage sensitive circuits. Increasing or decreasing the AC input voltage can also help locate intermittent problems that don't show up with normal line voltage applied to the device.

The ability to monitor the current or power drawn from the AC line often simplifies troubleshooting of power supply or power output stage problems. Abnormally high power consumption indicates a problem that might not be immediately recognized by abnormal operation, but which may cause problems in the future.

Finally, every device serviced should be checked to insure that exposed metal parts do not pose a shock hazard to the user. Safety tests are recommended by all equipment manufacturers. These tests often are not performed because the test procedures specified are difficult to interpret and perform.

The PR570 POWERITE II™ is an AC safety supply designed to insure that every factor related to AC power is correct. The operation is simplified, and all of the features needed to meet these needs are included in a single, compact instrument.

## **FEATURES**

---

The Sencore PR570 POWERITE II™ features six functions in one compact package. First, the PR570 includes an isolation transformer to provide isolation for devices which place an AC potential with respect to earth ground on their internal measurement reference points. This eliminates a shock hazard for service personnel and also provides safety for test equipment and the device being serviced.

Second, the PR570 includes AC line & receptacle checks to insure that the receptacle used to power the device under test is wired correctly and is supplying correct line voltage.

Third, the PR570 includes an adjustable AC transformer which allows you to vary the isolated AC output voltage from 0 to 140 volts AC. You can adjust to high or low output voltage to check regulator and shut-down circuit operation or adjust to high output voltage to cook out intermittent troubles.

Fourth, the PR570 provides safety tests to check for hot chassis operation and to test for potentially unsafe leakage current paths.

Fifth, the PR570 provides an adjustable output current trip to allow you to safely limit the amount of current available to any device connected to the isolated output.

Finally, the PR570 allows you to easily monitor the output current and power being drawn by the device connected to the isolated output socket, at the same time you monitor the input voltage.

# **SPECIFICATIONS**

---

## **ISOLATED OUTPUT**

**VOLTAGE:** 0-140 VAC typical at 117 VAC input, continuously variable.  
**CURRENT:** 3 amps continuous; 3-4 amps, 470 watts maximum  
intermittent use (5 minutes on, 5 minutes off).  
**OUTPUT LOADING:** Less than 12 volt drop in output with 3 amp  
load at 120 VAC.

## **AC VOLTS FUNCTIONS**

**AC LINE VOLTAGE TESTS:** Measures and displays the selected voltage:  
Hot to External Earth Ground, Hot to Safety Ground or Hot to  
Neutral.

**RANGE:** 0-150 VAC.

**ACCURACY:**  $\pm 3\%$  reading  $\pm 2$  counts, calibrated at 117 VAC.

**RESOLUTION:** 1 volt.

**PROTECTION:** 240 VAC.

**ISOLATED OUTPUT VOLTAGE:** Measures and displays voltage at  
isolated output. Same as Line Voltage Tests.

## **OUTPUT CURRENT MONITOR**

**RANGE:** 0-4 amps

**ACCURACY:**  $\pm 3\%$  of reading  $\pm 2$  counts.

**RESOLUTION:** 10 mA.

## **OUTPUT POWER MONITOR**

**MEASUREMENT:** True Power

**RANGE:** 0 to 470 watts.

**ACCURACY:**  $\pm 5\%$  of reading  $\pm 2$  counts.

**RESOLUTION:** 1 watt

## **ADJUSTABLE CURRENT TRIP**

**RANGE:** 0-4 amps

**ACCURACY:**  $\pm 10\%$  of reading  $\pm 20$  mA.

**RESOLUTION:** Adjustable in 10 mA increments.

**TRIP TIME:** 0.3 seconds max. with 200% overload.

## **HOT CHASSIS TEST**

**MEASUREMENT:** Ties hi and lo lead of primary together and measures leakage to exposed metal with power off.

**RANGE:** 0 to 1999  $\mu$ A

**ACCURACY:**  $\pm 3\%$  if reading  $\pm 2$  counts

**RESOLUTION:** 1  $\mu$ A

**PROTECTION:** 150 mA RMS, 150 V max.

## **SAFETY LEAKAGE TEST**

**MEASUREMENT:** Referenced to either side of isolated output jack. (Automatically toggles high and low line and open and closed safety ground and displays highest reading).

**RANGE:** 0 to 1999  $\mu$ A

**ACCURACY:**  $\pm 3\%$   $\pm 2$  counts

**RESOLUTION:** 1  $\mu$ A

**PROTECTION:** 150 mA RMS, 150 V max.

**CAL CHECK:** 100  $\mu$ A,  $\pm 3\%$   $\pm 2$  counts with isolated output at 120 VAC.

## **PROTECTION**

**AC INPUT:** 4 amp, type 3AG slo-blo fuse.

**ISOLATED OUTPUT:** Adjustable current trip, 0 to 4 amp.

## **GENERAL**

**OPERATING TEMPERATURE:** 15° to 35° C (59° to 95° F)

**MAXIMUM OPERATING HUMIDITY:** 90%, no condensation.

**WARM-UP TIME:** Unit fully operational at turn on. Allow 20 minutes warm-up to meet full specifications.

**SIZE:** 6" x 11.5" x 12" (15.2 x 29.2 x 25.4) HWD.

**WEIGHT:** 22 lbs (10 kg).

**POWER:** 105 to 125 VAC, 60 Hz, .4 amps idle current with no output load.

## **SUPPLIED ACCESSORIES**

Safety Leakage Probe (39V1) - Used to connect the SAFETY PROBE INPUT jack to points being tested during the HOT CHASSIS and LEAKAGE tests.

Ground Lead (39V2) - Used to connect the EXTERNAL EARTH GND jack to an earth ground connection.

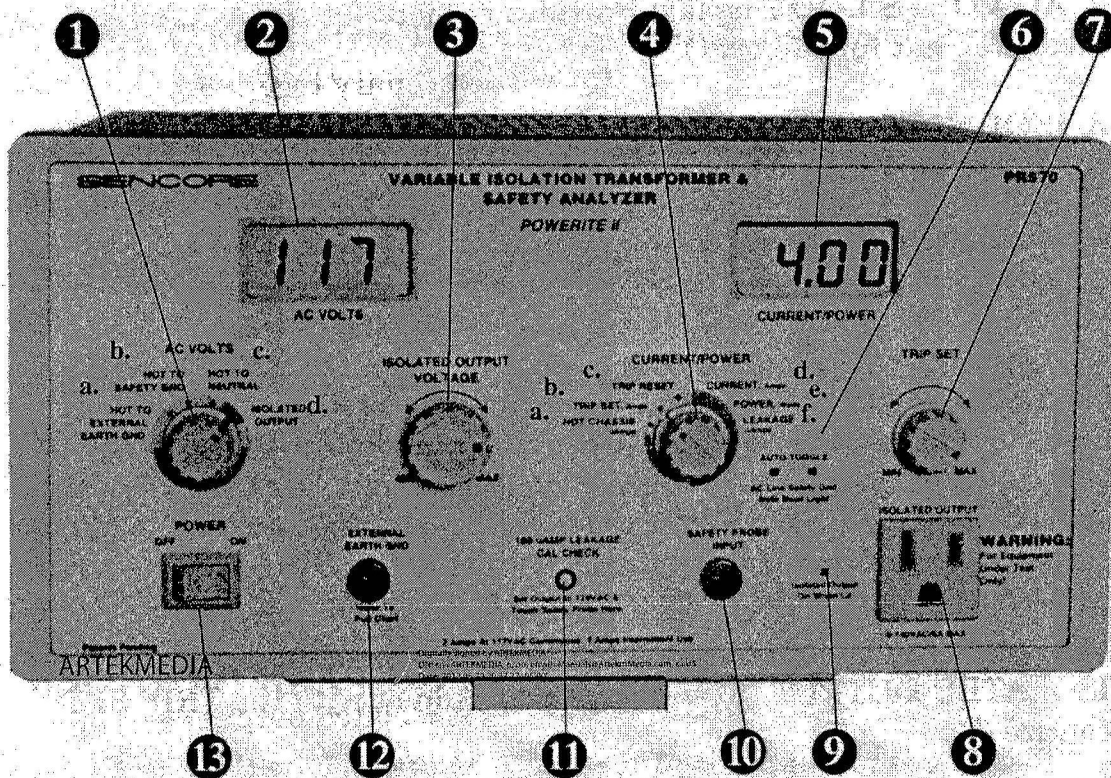

Fig. 1 - Location of controls and features of the PR570

## CONTROLS

1. **AC VOLTS Function Switch:** Select desired function to read AC volts on the AC VOLTS LCD Display (2).

1a. **HOT TO EXTERNAL EARTH GND:** Select to monitor the AC voltage between the AC line hot lead and an EXTERNAL EARTH GND (12).

1b. **HOT TO SAFETY GND:** Select to monitor the AC voltage between the AC line hot lead and the AC line third wire safety ground.

1c. **HOT TO NEUTRAL:** Select to monitor the AC voltage between the AC line hot lead and the AC line neutral lead.

1d. **ISOLATED OUTPUT:** Select to monitor the AC voltage present at the ISOLATED OUTPUT socket (8).



2. **AC VOLTS LCD Display:** Provides readout for the AC VOLTS measurement functions (1).
3. **ISOLATED OUTPUT VOLTAGE Control:** Adjust the isolated AC voltage present at the ISOLATED OUTPUT socket (8) from 0-140 volts AC. Read variable output voltage on the AC VOLTS LCD by selecting ISOLATED OUTPUT (1d) on the AC VOLTS function switch.
4. **CURRENT/POWER Function Switch:** Select desired function to read current or power on the CURRENT/POWER LCD Display (5).
- 4a. **HOT CHASSIS:** Select to check for hot chassis condition without powering device under test. Read the HOT CHASSIS leakage current on CURRENT/POWER LCD.
- 4b. **TRIP SET:** Select to monitor the current level at which the ISOLATED OUTPUT (8) will trip open. Adjust with the TRIP SET control (7).
- 4c. **TRIP RESET:** Select to reset the current trip at the ISOLATED OUTPUT (8).
- 4d. **CURRENT:** Select to monitor up to 4 amps of current being drawn by the device connected to the ISOLATED OUTPUT (8).
- 4e. **POWER:** Select to monitor up to 470 watts of power being drawn by the device connected to the ISOLATED OUTPUT (8).
- 4f. **LEAKAGE:** Select to test leakage to any external metallic parts on the device under test with normal line voltage applied and device operating. Read leakage current on CURRENT/POWER LCD.
5. **CURRENT/POWER LCD Display:** Provides readout for the CURRENT/POWER measurement functions (4).
6. **AUTO-TOGGLE LEDs:** Alternately light while LEAKAGE mode (4f) is selected to indicate leakage tests to both sides of the AC line and with safety ground both open and closed.
7. **TRIP SET Control:** Adjust to set the current level at which the ISOLATED OUTPUT (8) will trip open. Monitor the current trip level on the CURRENT/POWER LCD by selecting TRIP SET (4b) on the CURRENT/POWER function switch.

8. **ISOLATED OUTPUT Socket:** Provides connection of device being tested to variable isolated AC voltage.

9. **ISOLATED OUTPUT ON WHEN LIT LED:** Lights to indicate when AC voltage is present at the ISOLATED OUTPUT socket (8).

10. **SAFETY PROBE INPUT Jack:** Insert safety leakage probe before making leakage tests with LEAKAGE (4f) mode selected.

11. **LEAKAGE CAL CHECK Jack:** Touch tip of safety leakage probe to jack with isolated output voltage set to 120 volts AC. Read 100 uamps of current ( $\pm 5$  uamps) on the CURRENT/POWER LCD to confirm calibration of LEAKAGE function (4f).

12. **EXTERNAL EARTH GND Jack:** Connect to a known earth ground connection while performing HOT TO EXTERNAL EARTH GND (1a) AC VOLTS test.

13. **POWER Switch:** Applies AC power to the input of the PR570.

# OPERATION

## INTRODUCTION

---

Before operating your PR570 for the first time, take a few minutes to read through the Operation section of this manual. Familiarize yourself with the features and tests which you can perform with the PR570. The PR570 is not only an isolation transformer, it is a troubleshooting tool which will aid you in your daily service as well as provide you and your equipment with protection against shock hazards.

## POWER CONNECTION

---

The PR570 is designed to operate from a 105 to 125 VAC, 60 Hertz power line. The PR570 should be plugged into a properly grounded three wire outlet for maximum safety.

## FUSE REPLACEMENT

---

### WARNING

Always replace the fuse on the rear panel of the PR570 with a 3AG, 4 Amp slo-blo type fuse, Sencore part number 44G23, or its exact equivalent. Any other rating or size fuse may cause internal damage to the PR570 and will void all warranties.

### ATTENTION

Toujours remplacer le fusible placé à l'arrière du PR570 par un fusible 3AG, 4 Amp de type slo-blo, numero de piece Sencore 44g23 ou bien un equivalent exact. L'utilisation de tout autre type de fusible peut engendrer des dommages au PR570 et supprime toutes les garanties.

The PR570 uses a 3AG, 4 Amp slo-blo fuse, mounted on the rear panel, to protect from damage due to excessive current. If the LED on the power switch fails to light when the PR570 is plugged into a powered outlet and the power switch is turned on, check the fuse.

# **AC VOLTS FUNCTIONS**

---

## **HOT TO EXTERNAL EARTH GND TEST**

This function monitors the AC voltage between the AC line hot lead and an external earth ground. This allows you to check the AC receptacle for proper polarity of the hot lead with respect to earth ground, indicated by normal line voltage. If the HOT TO NEUTRAL test indicates normal line voltage, but the HOT TO EXTERNAL EARTH GND test doesn't, it indicates that wiring to the receptacle is improperly reversed.

To check the AC voltage between the AC line hot lead and an external earth ground:

1. Plug the PR570 into a properly grounded three wire AC outlet.
2. Turn the PR570 ON and switch the AC VOLTS control to the HOT TO EXTERNAL EARTH GND position.
3. Connect the ground lead between the EXTERNAL EARTH GND jack and a known good earth ground connection. This might include electrical conduit, cold water plumbing, or heating/cooling duct work.
4. Read the AC voltage between the AC line hot lead and earth ground on the AC VOLTS LCD.

## **HOT TO SAFETY GND TEST**

This function monitors the AC voltage between the AC line hot lead and the AC line third wire safety ground. This allows you to check the AC receptacle for proper connection of the safety ground to earth ground. This tests for the possibility of a reversed line connection or an open safety ground.

To check the AC voltage between the AC line hot lead and the AC line safety ground lead:

1. Plug the PR570 into a properly grounded three wire AC outlet.
2. Turn the PR570 ON and switch the AC VOLTS control to the HOT TO SAFETY GND position.

3. Read the AC voltage between the AC line hot lead and the AC line third wire safety ground on the AC VOLTS LCD.

### **HOT TO NEUTRAL TEST**

This function monitors the AC voltage between the AC line hot lead and the AC line neutral lead. This allows you to check the AC receptacle for normal line voltage either with or without a load.

To check the AC voltage between the AC line hot lead and the AC line neutral lead:

1. Plug the PR570 into a properly grounded three wire AC outlet.
2. Turn the PR570 ON and switch the AC VOLTS control to the HOT TO NEUTRAL position.
3. Read the AC voltage between the AC line hot lead and the AC line neutral lead on the AC VOLTS LCD.

### **ISOLATED OUTPUT VOLTAGE ADJUSTMENT**

The PR570 POWERITE II™ variable voltage output is 0 to 140 volts AC. This is very useful for troubleshooting power supply problems, start up circuits and checking circuit repairs at reduced voltage before applying full voltage to them. The AC VOLTS LCD displays in AC volts to allow you to monitor the voltage at the ISOLATED OUTPUT.

*NOTE: Adjusting the ISOLATED OUTPUT VOLTAGE control changes the AC voltage at the ISOLATED OUTPUT regardless of which position the AC VOLTS control is switched to.*

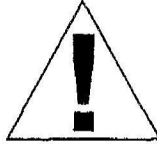

### **WARNING**

Never connect more than one device at a time to the ISOLATED OUTPUT. If more than one device is connected to the output of the PR570, the isolation is defeated between the devices and a shock hazard may exist between them.

Also, never connect test equipment to the PR570 ISOLATED OUTPUT. Connect only devices which are being serviced. Test equipment should be powered directly from the AC outlet in order to maintain maximum safety and noise rejection.

### **ATTENTION**

Ne jamais connecter plus d'un appareil sur la sortie isolée (ISOLATED OUTPUT) du PR570. Si plusieurs appareils sont connectés sur la sortie du PR570, il n'y a plus d'isolation car les masses des différents appareils sont reliées. Dans ce cas, un danger de choc électrique peut être présent entre les deux appareils.

De plus, ne jamais connecter d'équipements de mesures sur la sortie isolée (isolated output) du PR570. Seuls les appareils qui sont en cours de réparation doivent être connectés. Les équipements de mesures doivent être branchés directement sur le secteur afin de conserver une sécurité maximale et de limiter le bruit.

To use the Variable Isolated Output Voltage function of the PR570:

1. Plug the PR570 into a properly grounded three-wire AC outlet and switch the POWER switch to the ON position.
2. Switch the AC VOLTS control to the ISOLATED OUTPUT position.
3. Adjust the ISOLATED OUTPUT VOLTAGE control for the desired output voltage as indicated on the AC VOLTS LCD.

# **CURRENT/POWER FUNCTIONS**

---

## **HOT CHASSIS TEST**

This test checks for a hot chassis condition in the device under test without powering the device. This allows you to detect problems in a device's primary power circuit without having to apply power to the device. It also helps you isolate problems identified by the LEAKAGE test. If the LEAKAGE test is bad but the HOT CHASSIS test indicates less than 500 uamps, the leakage must originate in the secondary power circuit. If the LEAKAGE test is bad and the HOT CHASSIS test indicates over 500 uamps, the leakage originates in the primary power circuit.

To perform the Hot Chassis test:

1. Plug the PR570 into a properly grounded three-wire AC outlet and switch the POWER switch to the ON position.
2. Switch the AC VOLTS control to the ISOLATED OUTPUT position and adjust the ISOLATED OUTPUT VOLTAGE control for 120 volts as indicated on the AC VOLTS LCD.
3. Switch the CURRENT/POWER function switch to the HOT CHASSIS position.
4. Plug the device to be tested into the ISOLATED OUTPUT socket.
5. Plug the safety leakage probe into the SAFETY PROBE INPUT, touch the tip of the probe to the chassis or internal ground reference point for the device, and read the HOT CHASSIS leakage current on the CURRENT/POWER LCD.

## **CURRENT TRIP SET**

The PR570 provides variable current trip protection at the ISOLATED OUTPUT. The current trip level is easily adjustable from 0-4 amps. This allows you to preset a maximum allowed current for the device under test. If the device draws more than the preset current, the ISOLATED OUTPUT trips off. This removes AC voltage from the device under test and stops the current flow through the device.

To set the current trip point:

1. Plug the PR570 into a properly grounded three-wire AC outlet and switch the POWER switch to the ON position.
2. Switch the AC VOLTS control to the TRIP SET position and adjust the TRIP SET control to the desired current trip point, as indicated on the CURRENT/POWER LCD.
4. Return the function switch to the desired operating mode.

### **CURRENT TRIP RESET**

Once a device connected to the ISOLATED OUTPUT draws more than the preset current, The ISOLATED OUTPUT trips off and remains off until it is reset with the TRIP SET function.

To reset the current trip:

1. Switch the CURRENT/POWER function switch to the TRIP RESET position.
2. Return the function switch to the desired operating mode.

*NOTE: When the PR570 is first turned on, the current trip is active and the ISOLATED OUTPUT is not energized. To turn on the output, follow the procedure above to reset the current trip.*

### **ISOLATED OUTPUT CURRENT MEASUREMENT**

The PR570 will deliver up to 3 Amps continuous and 3 to 4 Amps intermittent duty (5 minutes on, 5 minutes off). The meter is in series with the ISOLATED OUTPUT and measures the actual current drawn by the device under test regardless of the voltage being applied. The ISOLATED OUTPUT VOLTAGE control needs to be set to 120 volts only if the current readings are being compared to the rated current draw of the device under test.

To measure the current drawn by a device under test:

1. Plug the PR570 into a properly grounded three-wire AC outlet and switch the POWER switch to the ON position.



2. Switch the AC VOLTS control to the ISOLATED OUTPUT position and adjust the ISOLATED OUTPUT VOLTAGE control for the desired output voltage as indicated on the AC VOLTS LCD. This would be 120 volts for comparing the current draw to manufacturer's specifications or a lower voltage while troubleshooting a defective circuit.

3. Switch the CURRENT/POWER switch to the TRIP RESET position and return it to the CURRENT position.

4. Plug the device to be tested into the ISOLATED OUTPUT and turn the device on.

5. Read the current being drawn by the device, in amps, on the CURRENT/POWER LCD.

### **ISOLATED OUTPUT POWER MEASUREMENT**

The PR570 will deliver up to 350 watts continuous, and 350 to 470 watts intermittent duty (5 minutes on, 5 minutes off).

*NOTE: The PR570 measures true output power by taking the power factor of the circuit into account. There may be a slight difference between the true power and the apparent power, as calculated from voltage and current measurements, due to the inductive or capacitive nature of some circuits. This slight difference can be ignored in normal service work.*

To measure the power drawn by a device under test:

1. Plug the PR570 into a properly grounded three-wire AC outlet and switch the POWER switch to the ON position.

2. Switch the AC VOLTS control to the ISOLATED OUTPUT position and adjust the ISOLATED OUTPUT VOLTAGE control for 120 volts as indicated on the AC VOLTS LCD.

3. Switch the CURRENT/POWER switch to the TRIP RESET position and return it to the POWER position.

4. Plug the device to be tested into the isolated output on the PR570 and turn the device on. Readjust the PR570 ISOLATED OUTPUT VOLTAGE control, if necessary, to bring the output back to 120 volts.

5. Read the power being drawn by the device, in watts, on the CURRENT/POWER LCD.

## **LEAKAGE TEST**

The leakage test is performed to determine if there is any AC line leakage to any exposed metal part of the device under test. Any leakage indicates a potential shock hazard to anyone touching the exposed part that has leakage. This test is specified on the safety page of most manufacturer's service literature and is recommended by all manufacturers. The leakage test should be performed on a completed device that is in the cabinet and ready to return to the customer. The PR570 simplifies this leakage test with the built-in Auto-Toggle leakage circuit. Simply touch the safety leakage probe to each exposed metal part on the outside of the device cabinet and read the leakage current on the CURRENT/POWER LCD.

*NOTE: The Leakage test must be made with no connections to the device except the Safety Leakage Probe. If any piece of equipment other than the PR570 is connected to the device the leakage readings may be inaccurate.*

To perform the Leakage test:

1. Plug the PR570 into a properly grounded three-wire AC outlet and switch the POWER switch to the ON position.
2. Switch the AC VOLTS control to the ISOLATED OUTPUT position and adjust the ISOLATED OUTPUT VOLTAGE control for 120 volts as indicated on the AC VOLTS LCD.
3. Switch the CURRENT/POWER switch to the TRIP RESET position and return it to the LEAKAGE position.
4. Plug the device to be tested into the isolated output on the PR570 and turn the device on. Readjust the PR570 ISOLATED OUTPUT VOLTAGE control, if necessary, to bring the output back to 120 volts.
5. Plug the Safety Leakage Probe into the SAFETY PROBE INPUT jack and touch the probe tip to every piece of exposed metal; including screw heads, antenna terminals, knobs, all control shafts with the knobs removed, handles, or anything that appears to be metallic.

6. Read the leakage current of each part on the CURRENT/POWER LCD.

Any metallic part that reads overrange on the CURRENT/POWER LCD (blank display with a digit 1 on the left) is connected directly to one side of the AC line.

### **DETERMINING THE ALLOWABLE LEAKAGE LEVEL**

The maximum allowable leakage level of an electronic device is printed in the manufacturer's service literature on the safety page. This is the maximum level of leakage that conforms with all standards to insure customer safety. The present maximum legal level of leakage on consumer electronic devices is 500 microamps. Some manufacturers publish a figure that is lower than the 500 microamp level, as a safety margin. Check each device to the manufacturer's specified safe leakage level.

Televisions manufactured prior to 1972 were designed to meet a 750 micro-amp leakage level. Be sure to check these sets at the level specified.

### **TESTING LEAKAGE ON THREE-WIRE DEVICES**

The PR570 leakage test is designed to operate exactly the same on a device with a two-wire AC line cord or a 3-wire (grounded) AC line cord. The third-wire ground connection on the ISOLATED OUTPUT jack is connected to AC line safety ground through the power cord of the PR570. During the LEAKAGE test, the ground is periodically switched open to test the leakage with both open and closed ground. The leakage between the AC line and any exposed metallic part will be properly read by simply touching the safety leakage probe to the chassis. Do not defeat the third-wire ground on any device which is equipped with a three-wire plug.

### **CHECKING THE CALIBRATION OF THE LEAKAGE TEST**

The calibration of the PR570 leakage test can be tested at any time so that you are confident that the readings obtained during the test are correct.

1. Plug the PR570 into a properly grounded three wire AC outlet.

# PR570

## POWERITE II

### Schematic & Parts List

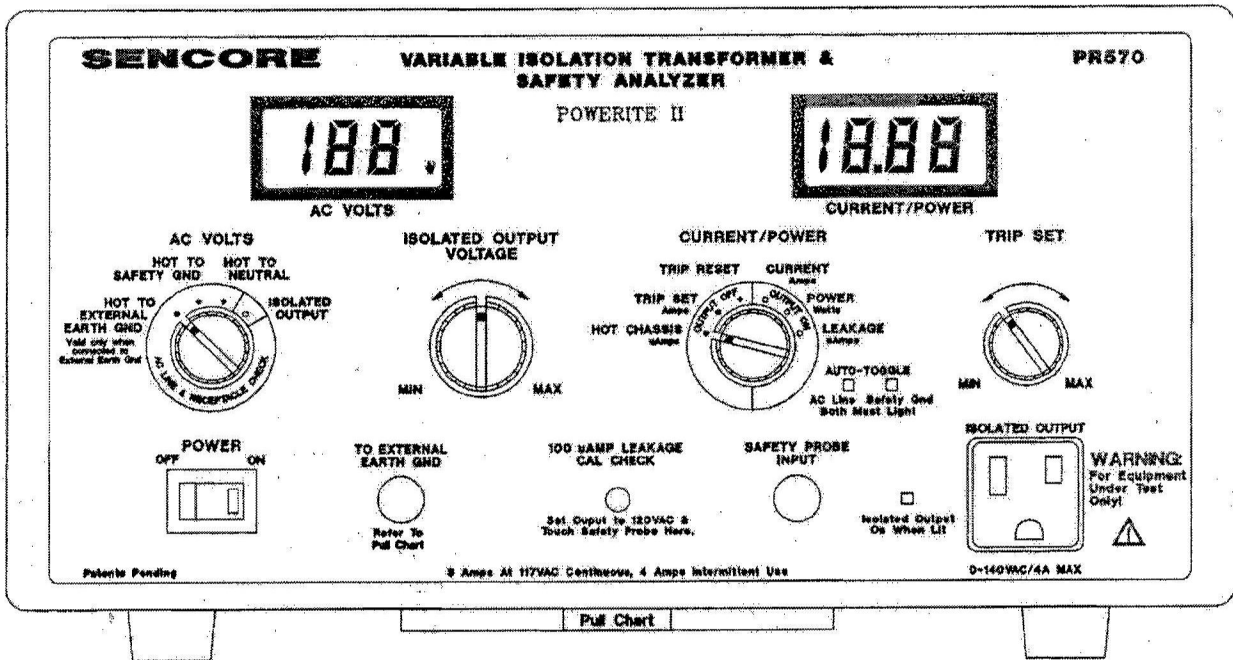

**SENCORE**  
3200 Sencore Drive, Sioux Falls, SD 57107  
CALL 1-800-SENCORE (736-2673)

SCHEMATIC REFERENCE	PARTS NO.	DESCRIPTION
C101,121,137,138	224G168	CAPACITOR, MYLAR, .22UF, 100V, 10%
C102,103,104,110	224G216	CAPACITOR, MYLAR, .1UF, 100V, 10%
C113	224V1	CAPACITOR, MYLAR, .022UF, 100V, 10%
C131	224V4	CAPACITOR, MYLAR, .47UF, 100V, 10%
CR111,116,117	220V1	LED, 20MA, T-1 3/4
F1	44G23	FUSE, 4A, 3AG, SLO BLO
IC101,105	269V4	IC, NJU9201BD, A/D-LCD DRIVER
IC102	269G7-A	IC, MC14001BCP, QUAD NOR
IC103,112	269G135	IC, 7812, +12V REG
IC104	269G338	IC, 7912, -12V REG
IC106	269V1	IC, AD706, OP-AMP
IC107	269G764	IC, AD711, OP-AMP
IC108	269V3	IC, AD633, ANALOG MULTIPLIER
IC109	269G46	IC, TL084, QUAD OP-AMP
IC110	269G6-B	IC, MMC14040BCP, RIPPLE COUNTER
IC113,114	223V1	LCD, 3 1/2 DIGIT,
L101,102	241V1	RELAY, 12V COIL, 5A
Q107,Q108	250G34	TRIAC, MAC97A4
R1	214C1-123	RESISTOR, 12K, 2W, 5%
R2	114V1	RESISTOR, WW, 1K, 25W, 5%, 300PPM
R102,156	214A38-1005A	RESISTOR, METAL FILM, 100K, 1/4W, 1%, 100PPM
R103,183	214C1-512	RESISTOR, 5.1K, 1/4W, 5%
R104,109,184	215V1-10K	POT, 10K, 1/2W
R113,148,159,174	215V1-50K	POT, 50K, 1/2W
R115	214C1-304	RESISTOR, 300K, 1/4W, 5%
R117,118,199,120	214C29-1006A	RESISTOR, METAL FILM, 1M, 1/4W, 1%, 50PPM
R127	214A38-1000A	RESISTOR, METAL FILM, 1, 1/4W, 1%, 100PPM
R128	214C1-131	RESISTOR, 130, 1/2W, 5%
R135	214C1-511	RESISTOR, 510, 1/4W, 5%
R136	215V1-1K	POT, 1K, 1/2W
R144,171,172,173	214C1-134	RESISTOR, 130K, 1/4W, 5%
R145,153	214V2	RESISTOR, WW, 2.7K, 10W, 5%
R147	214C26-2152B	RESISTOR, METAL FILM, 215, 1/42, 1%, 50PPM
R151	214A38-1003A	RESISTOR, METAL FILM, 1K, 1/4W, 1%, 100PPM
R152,164,166	214A38-1006A	RESISTOR, METAL FILM, 1M, 1/4W, 1%, 100PPM
R154	214C10-101	RESISTOR, 100, 2W, 5%
R155	214A38-1115A	RESISTOR, METAL FILM, 110K, 1/4W, 1%, 100PPM
R157,158	214A38-7874A	RESISTOR, METAL FILM, 78.7K, 1/4W, 1%, 100PPM
R160	214A38-4994A	RESISTOR, METAL FILM, 49.9K, 1/4W, 1%, 100PPM
R161	14A38-4325A	RESISTOR, METAL FILM, 432K, 1/4W, 100PPM
R163,165	214A38-1004B	RESISTOR, METAL FILM, 10K, 1/4W, 1%, 50PPM
R175	214A38-1825A	RESISTOR, METAL FILM, 182K, 1/4W, 1%, 100PPM
R178	214C26-9533B	RESISTOR, METAL FILM, 9.53K, 1/4W, 1%, 50PPM
R179	214C26-8664A	RESISTOR, METAL FILM, 86.6K, 1/4W, 1%, 50PPM
R181	214C26-1206B	RESISTOR, METAL FILM, 1.2M, 1/4W, 1%, 50PPM
R190	214A38-2004A	RESISTOR, METAL FILM, 20K, 1/4W, 1%, 100PPM
R191	215V2-470	POT, 470, 1/2W, PCB/PANEL
SW101,102	225G371	SWITCH, 2P6T, ROTARY
T101	228V3	TRANSFORMER, CURRENT SENSE



### WARNING

*Avoid damage to parts caused by static electricity!*

Most solid state devices and film resistors are susceptible to damage due to discharge of static electricity. Observe the following precautions when a PC board is removed from the unit, or when handling components.

1. The person handling the part must be grounded through a 1 megohm resistor via a wrist strap or similar ground connection.
2. A PC board or component should never be placed on an insulated surface. The surface must be grounded (through an 11 megohm resistor) and conductive.
3. All replacement parts must be left in a completely enclosed, conductive container or package until ready for use. The person removing the part from the container must be properly grounded. All parts susceptible to static damage are shipped in conductive containers when reordered from the Sencore Service Department.

Components not listed are standard replacement parts and may be purchased locally. When ordering parts, please specify instrument model number, schematic reference, part number, and description. Please include remittance (check or money order) with your order otherwise invoice will be shipped C.O.D. Minimum billing is \$5.00.

# BLOCK DIAGRAM

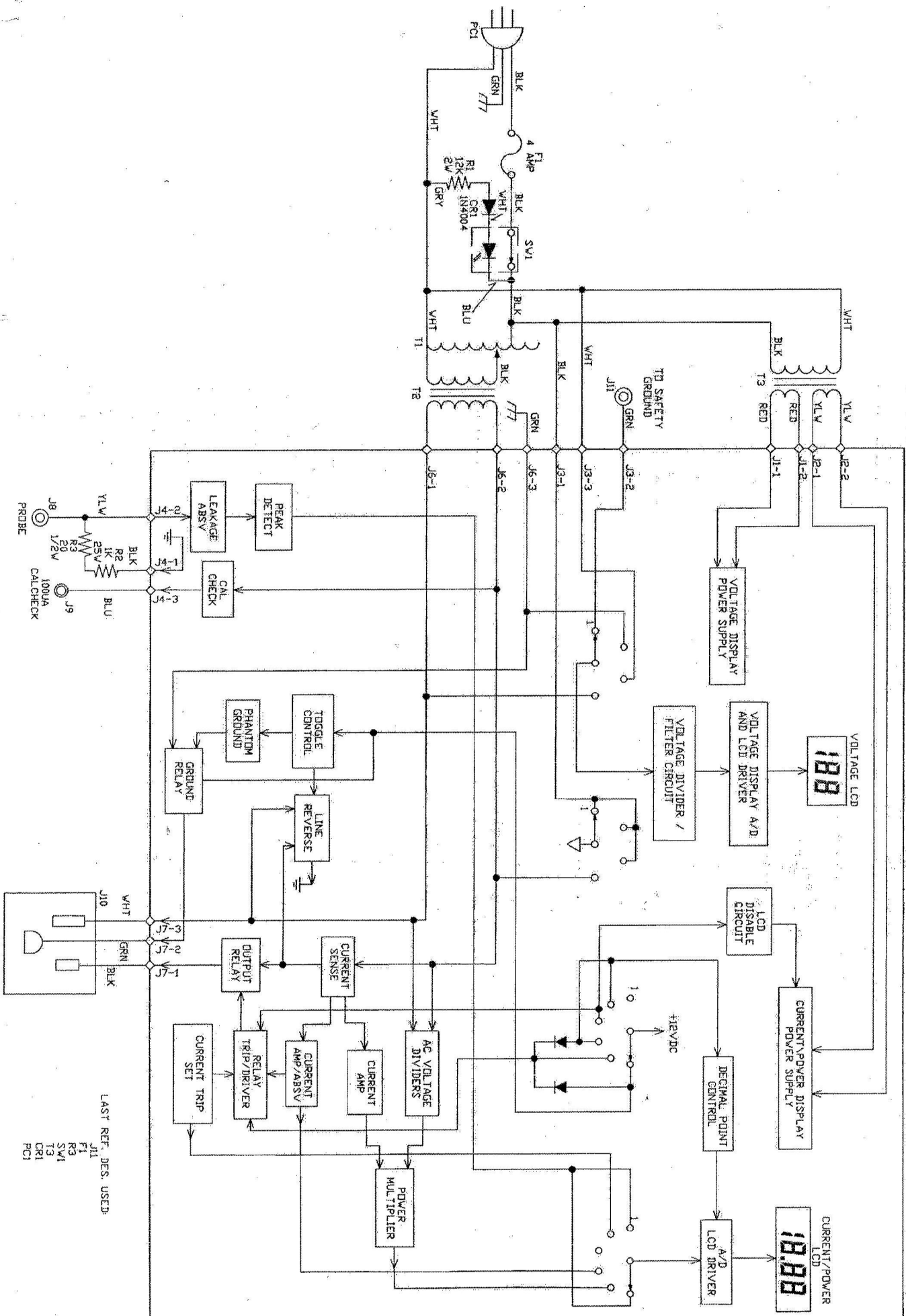

LAST REF. DES. USED.

- J11 WHT
- F1 BLK
- R3 GRN
- SW1 WHT
- T3 RED
- T2 BLK
- T1 WHT
- CR1 GRY
- PCI BLK

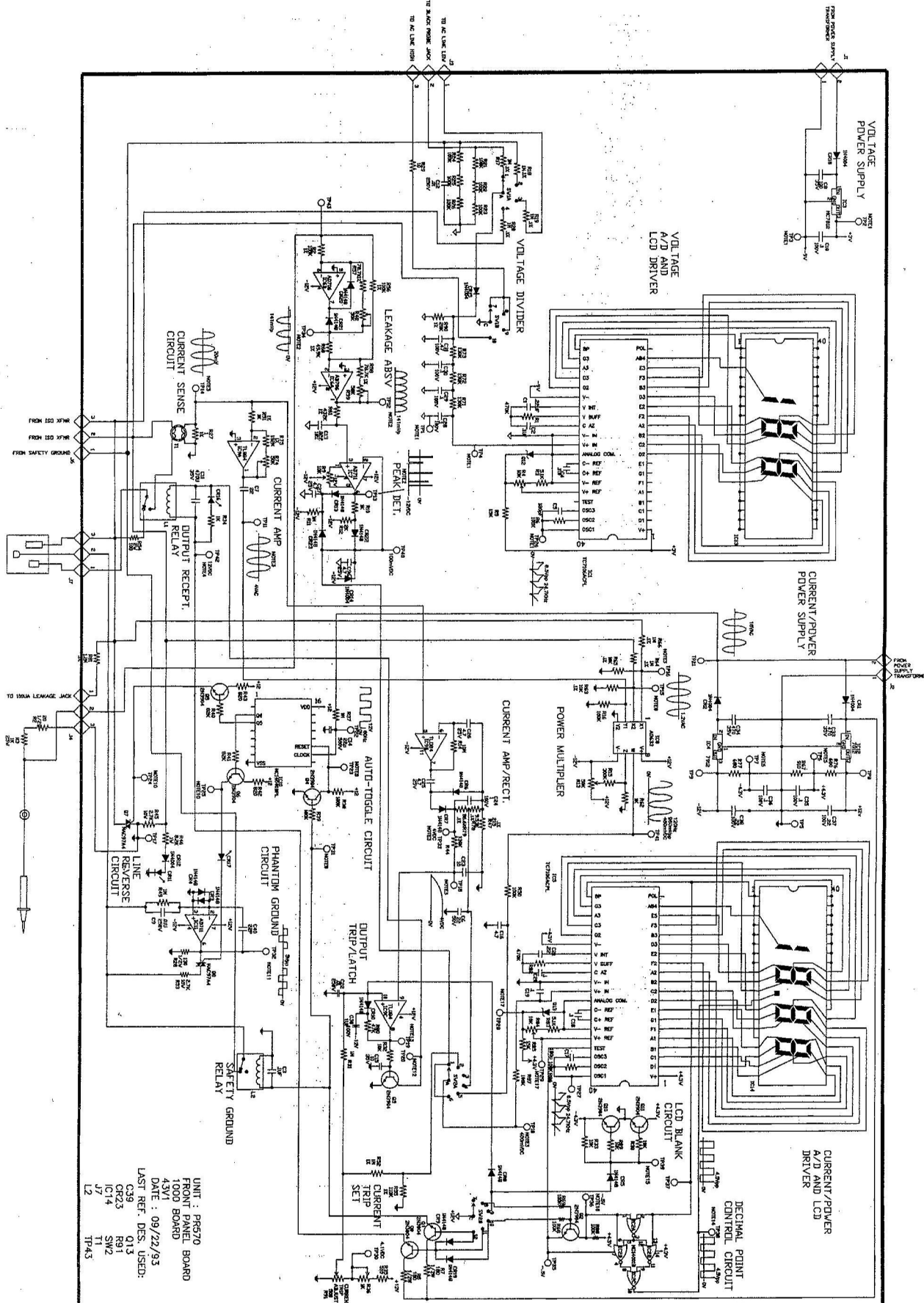

UNIT : PRC270  
 FROM PARENT BOARD  
 1000 BOARD  
 43V1  
 DATE : 09/22/93  
 LAST REF. DES. USED:  
 C39 013  
 CR23 R91  
 IC14 SW2  
 J7 T1  
 J2 TP43

# WARRANTY

Your PR570 "Powerite II" has been built to the highest quality standards in the industry. Each unit has been tested, aged under power for at least 24 hours, then, was retested to insure it met all published specifications after aging. Your instrument is fully protected with a 1 year warranty and Sencore's exclusive 100% Made Right Lifetime Guarantee in the unlikely event a defect was missed. Details are covered in a separate document included with your instrument.

## SERVICE

The Sencore Factory Service Department provides all "in and out of warranty" service and complete calibration services for all Sencore instruments. No local service centers are authorized to repair Sencore instruments. Factory service insures you the highest quality work, the latest circuit improvements, factory parts, and the fastest turnaround time possible. Most service repairs are completed within 72 hours of their receipt.

### Repacking For Shipment

Save the original packing materials for reuse should you ever need to ship your PR570 or return it to the Sencore Factory Service Department for repair or calibration. If the original packing materials are unavailable or unfit for reuse, repack the PR570 according to the following guidelines.

1. Use a corrugated shipping container that has a test strength of 50 lbs. and internal dimensions of at least 12" x 18" x 18".
2. Enclose the following information: Owners address, billing information, purchase order (if applicable), name and phone number of contact person, description of problem and reason for return. No return authorization is required.
3. Enclose the unit inside a plastic bag to protect its finish and prevent foreign material from getting inside.
4. Cushion the unit with a minimum of 3" of padding material. Pack the padding tightly enough to prevent the unit from shifting during shipment.
5. Seal all seams on the container with strapping tape.
6. Send the packed unit to address listed below (we recommend shipping via United Parcel Service).

Parts may be ordered directly from the Service Department.

We reserve the right to examine defective components before an in-warranty replacement is issued.

**Sencore Factory Service**  
3200 Sencore Drive  
Sioux Falls, SD 57107  
Toll Free: 1-800-SENCORE  
Fax: 605-335-6379

Fill in for your records:

Purchase Date \_\_\_\_\_ Serial Number \_\_\_\_\_ Run Number \_\_\_\_\_

*Note: Please refer to the run number if it is necessary to call the Sencore Factory Service Department. The run number may be updated when the unit is serviced.*



# SENCORE

**3200 Sencore Drive  
Sioux Falls, SD 57107  
Call 1-800-SENCORE (736-2673)**

*Innovatively designed  
with your time in mind.*