

SCR250

SCR & TRIAC TEST ACCESSORY

Operation and Application Manual

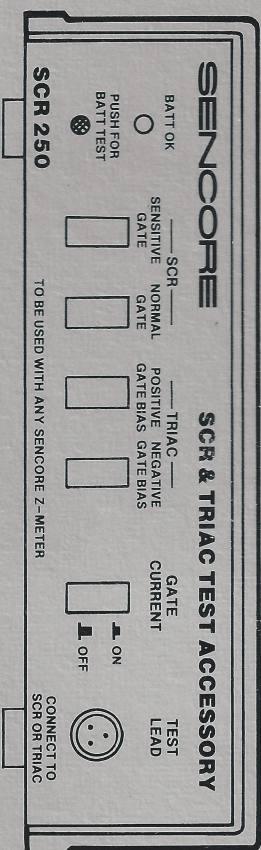

SENCORE

ELECTRONIC TEST EQUIPMENT

Innovatively Designed With Your Time In Mind

3200 Sencore Drive
Sioux Falls, South Dakota 57107
(605) 339-0100



SENCORE

3200 Sencore Drive, Sioux Falls, South Dakota 57107

WARNING

This accessory is to be operated only by a technically trained person who understands the shock hazard of applying up to 1000 volts to the component under test. Do not hold the component or test leads in your hand during the tests.

1. Do not attempt to check components in circuit. Before removing the component from the circuit, disconnect the AC power and discharge all filter capacitors.
2. Never exceed the limits of this accessory as given in the specification section, and the additional warnings in this manual.
3. Do not subject the component under test to more than its rated voltage. Applying more than the rated voltage to the component may destroy it or cause its case to rupture.
4. Be sure your equipment is in good order. Broken or frayed test leads can be extremely dangerous and can expose you to dangerous voltages.
5. Do not work alone on hazardous circuits. Always have another person close by in case of an accident. Remember, even a minor shock can be the cause of a more serious accident, such as falling against the equipment, or coming in contact with high voltages.

SCR250

SCR & TRIAC TEST ACCESSORY

Operation and Application Manual

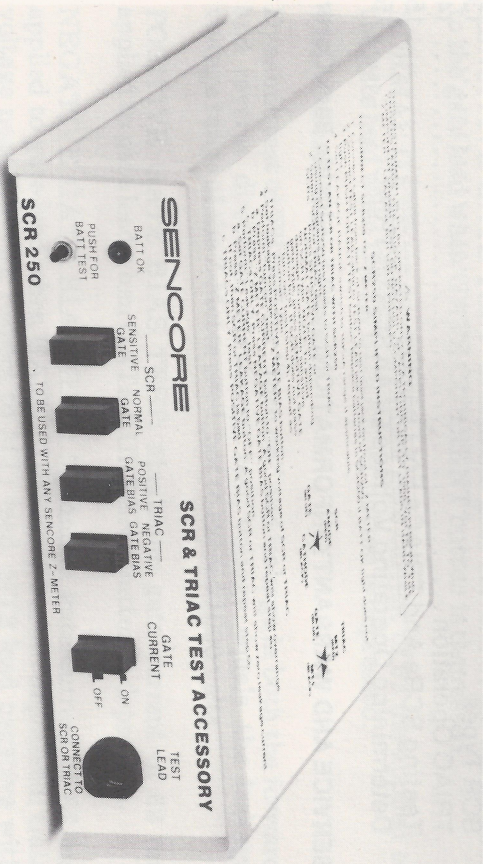

SENCORE

3200 Sencore Drive, Sioux Falls, South Dakota 57107

TABLE OF CONTENTS

SAFETY PRECAUTIONS	Inside Front Cover
DESCRIPTION	
Introduction	3
Specifications	3
Controls	5
OPERATION	
Introduction.....	6
Battery Installation/Replacement	6
Battery Test	7
Mounting The SCR250 On The "Z METER"	7
Connecting The SCR250 To The "Z METER"	9
Testing SCRs.....	10
Testing TRIACs.....	11
APPLICATION SECTION	
SCR Operation	12
SCR Types	13
TRIAC Operation	14
Testing SCRs And TRIACs For Leakage	15
Determining Operating Voltage Of An SCR Or TRIAC.....	15
SERVICE AND WARRANTY INFORMATION	Inside Back Cover

DESCRIPTION

Introduction

The SCR250 SCR & TRIAC Test Accessory is designed to be used with any Sencore Z-Meter to simplify SCR and TRIAC testing. The SCR250 dynamically tests both sensitive gate and normal gate SCRs for turn on and leakage under normal operating voltage conditions. The SCR250 also dynamically tests TRIACs for leakage and proper turn on in both the forward and reverse direction at normal operating voltage levels.

Specifications

SCR Tests (Out-of-Circuit)

Dynamic test of SCRs for "turn on" and for leakage. Maximum test voltage equals the maximum leakage voltage range of the Z-Meter used, not to exceed 1000 volts.

SENSITIVE GATE TEST: Maximum gate current of 2.6 ma applied to the gate lead when GATE CURRENT button is depressed.

NORMAL GATE TEST: Maximum gate current of 62 ma applied to the gate lead when GATE CURRENT button is depressed.

TRIAC Tests (Out-of-Circuit)

Dynamic test of TRIAC for "turn on" and leakage in both the forward and reverse direction. Maximum test voltage equals the leakage voltage range of the Z-Meter used, not to exceed 1000 volts.

POSITIVE GATE BIAS TEST: Maximum gate current of 62 ma applied to gate lead when GATE CURRENT button is depressed.

NEGATIVE GATE BIAS TEST: Maximum gate current of 62 ma applied to gate lead when GATE CURRENT button depressed. Gate voltage negative with respect to MT1 lead. MT2 lead negative with respect to MT1 lead.

General

TEMPERATURE RANGE (Typical): 32-130 degrees F.
POWER REQUIREMENTS: Three AA batteries required (not included). BATTERY OK LED will light if combined battery voltage drops below 3.5 volts.
SIZE: 1.8" X 6.2" X 6.5" HWD.
WEIGHT: 1.2 pounds with batteries.

TEST LEADS (supplied): one multiconductor test cable with color coded and labeled E-Z Hook® connectors for ease of connection to the SCR or TRIAC under test.

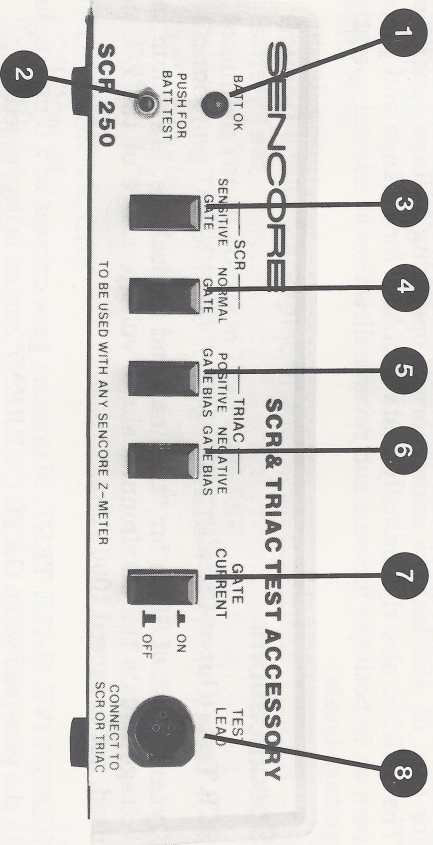

The front panel controls. (NOTE: Use the 39G196 TEST LEADS supplied with this unit only.)

Controls

1. **BATT OK LED**—lights if the battery voltage is sufficient for operation when the PUSH FOR BATT TEST button is pressed.
2. **PUSH FOR BATT TEST BUTTON**—Use with BATT OK LED to determine battery condition.
3. **SENSITIVE GATE SCR BUTTON**—Provides a low level gate current when GATE CURRENT button is in the "ON" position for testing sensitive gate type SCRs.
4. **NORMAL GATE SCR BUTTON**—Provides a normal level gate current when GATE CURRENT button is in "ON" position for testing normal gate type SCRs.
5. **POSITIVE GATE BIAS TRIAC BUTTON**— Provides a positive gate voltage when GATE CURRENT button is in the "ON" position.
6. **NEGATIVE GATE BIAS TRIAC BUTTON**—Provides a negative gate voltage when GATE CURRENT button is in the "ON" position. Reverses the polarity of the MT1 and MT2 TRIAC leads for checking the operation of the TRIAC in the "reverse" current direction.
7. **GATE CURRENT BUTTON**—Applies gate current to component under test.
8. **TEST LEAD JACK**—Supplies test voltages to component under test.

OPERATION

Introduction

The SCR250 connects to any Sencore Z-Meter to analyze SCRs and TRIACs for proper turn on and for excessive leakage current. The leakage voltage supply of the Z-Meter supplies the test voltage to dynamically test the SCR or TRIAC under normal operating voltage conditions. The Z-Meter's digital leakage current display shows the results of these tests. The SCR250 selects the desired test and supplies the gate current needed to turn the SCR or TRIAC on. The SCR250 can be easily operated using the information on the front panel. Simplified operating instructions are included on the top of the SCR250 for quick reference.

Battery Installation/Replacement

The SCR250 requires 3 "AA" batteries for operation. Three alkaline batteries typically give up to 3600 tests before they need to be replaced.

To install or replace batteries:

1. Remove the two screws securing the battery compartment cover on the rear of the SCR250.
2. Pull the battery holder out of the battery compartment using the pull tab.
3. Install 3 "AA" batteries, matching the polarity of the batteries and the polarity indicators on the battery compartment as shown in Figure 1.
4. Slide the battery holder back into the battery compartment.
5. Secure the battery compartment cover with the two screws.

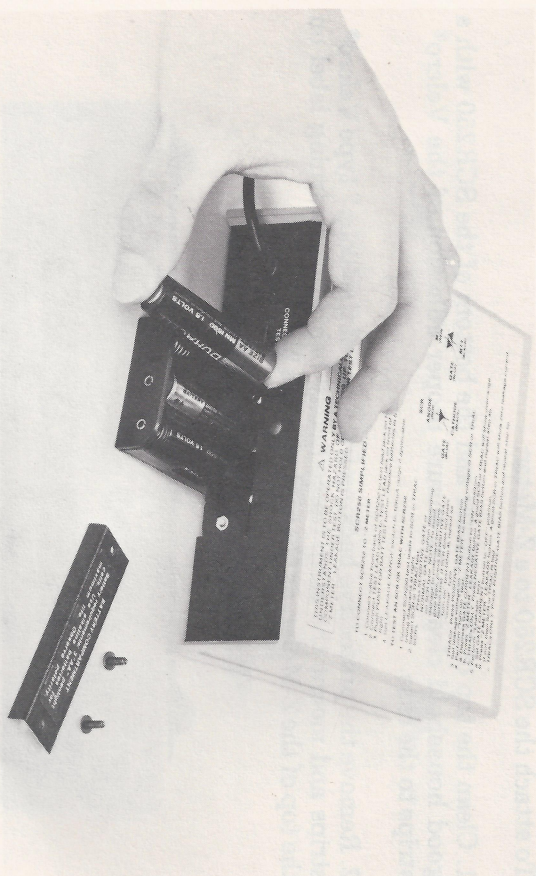

Fig. 1: Installing batteries.

Battery Test

The condition of the batteries is easily tested using the PUSH FOR BATT TEST button on the front of the SCR250. When the PUSH FOR BATT TEST button is pressed, a BATT OK LED will light if the batteries are good.

To test battery condition:

1. Press the PUSH FOR BATT TEST button on the front of the SCR250.
2. Observe the BATT OK LED. If the BATT OK LED does not come on, replace the batteries following the procedures given in the previous section on "Battery Installation/Replacement".

Mounting The SCR250 On The "Z METER"

The SCR250 can be placed in a convenient location beside the Z-Meter or it can be secured to the top of the Z-Meter for portable use.

The SCR250 can be secured to the Z-Meter using the Velcro® strips supplied with the SCR250. The SCR250 comes with two Velcro® strips called the "hooks" and two strips called the "loops". The strips called the "hooks" feel rough to the touch due to the many rows of nylon "hooks". The strips called "loops" feel much softer to the touch.

Velcro is a registered trademark of Velcro USA, Inc.

To attach the SCR250 to a Z-Meter:

1. Clean the top of the Z-Meter and the bottom of the SCR250 with a good household cleaner to ensure proper adhesion of the Velcro® strips to the case.
2. Remove the protective backing from one of the "loop" type Velcro® strips and mount the strip immediately behind the warning label on the top of the Z-Meter, as shown in Figure 2.

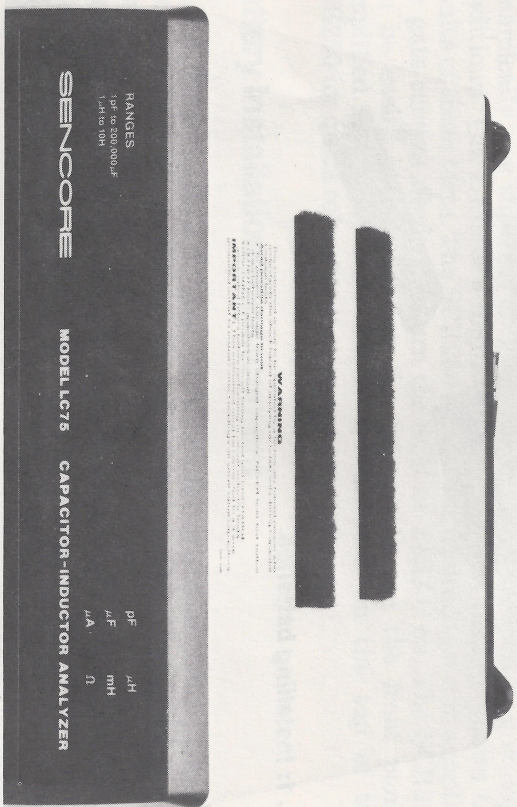

Fig. 2: Velcro® strips installed on the top of a "Z-METER".

3. Mount the other "loop" type Velcro® strip on the top of the Z-Meter two inches behind the previously installed Velcro® strip.
4. Place the SCR250 on top of the Z-Meter in the location desired. Determine where the Velcro® strips need to be placed on the bottom of the SCR250 in order to mate with the Velcro® strips installed on the Z-Meter.
5. Mount the two "hook" type Velcro® strips to the bottom of the SCR250 so they will mate with the two "loop" type Velcro® strips mounted on the Z-Meter.
6. Place the SCR250 on top of the Z-Meter and press down firmly to mate the Velcro® strips. The SCR250 is now securely fastened to the Z-Meter as shown in Figure 3.



Fig. 3: SCR250 mounted on top of a "Z-METER".

To remove the SCR250 from the Z-Meter (to replace the batteries, for example), simply pull up on one corner of the SCR250. The Velcro® strips will release their hold and the SCR250 can be removed.

Connecting The SCR250 To The "Z-METER"

The SCR250 is electrically connected to the Z-Meter through a cable coming out the back of the SCR250. A 39G196 TEST LEAD cable is also supplied with the SCR250 to connect to the SCR or TRIAC under test.

NOTE: Use the 39G196 test lead cable that is supplied with the SCR250. Do not use any other type of test lead with this instrument. The three E-Z Hook® connectors are color-coded for lead identification and are marked with the component leads they are to be connected to.

To connect the SCR250 to the Z-Meter:

1. Connect the cable from the back of the SCR250 to the BNC TEST LEAD jack on the front of the Z-Meter.
2. Connect the 39G196 TEST LEAD to the TEST LEAD jack on the front of the SCR250.

Testing SCRs

The following procedure checks an SCR for "turn-on" and leakage. The SCR must pass both checks before it is considered good.

To test an SCR with the SCR250:

1. Connect the SCR250 test leads to the SCR as follows:

- Connect the Blue E-Z Hook® to the SCR gate lead.
- Connect the Black E-Z Hook® to the SCR cathode lead.
- Connect the Red E-Z Hook® to the SCR anode lead.

WARNING

Be sure the test leads from the SCR250 are connected to the corresponding leads on the device under test. Incorrect lead connection can damage the device under test.

2. Press the SENSITIVE GATE button or the NORMAL GATE BUTTON depending on the type of SCR being tested.

NOTE: If the SCR type is unknown, press the SENSITIVE GATE button first. This supplies a lower current to check sensitive gate SCRs for proper turn-on. If the unknown SCR does not pass the "turn-on" test in step 4, press the NORMAL GATE button and repeat step 4b.

3. Set the APPLIED VOLTAGE or LEAKAGE VOLTAGE switch on the Z-Meter to the rated working voltage of the SCR under test. If the rated voltage is not known, refer to the section on "Determining the Operating Voltage of an SCR or TRIAC" found in the Applications section of this manual.

4. Perform the "turn-on" test:

- Depress the GATE CURRENT button to the "ON" position.
- Press the Z-Meter LEAKAGE button. The display on the Z-Meter will overrange with flashing "888" for a good SCR indicating that the device is "turned on" and current is flowing through it.

5. Perform the "leakage" test:

- Set the GATE CURRENT button to the "OFF" position.
- Press the Z-Meter LEAKAGE button. The display on the Z-Meter will show no leakage for a good device.

Testing TRIACS

The following procedure checks a TRIAC for "turn-on" and leakage in both the "forward" and the "reverse" direction. The TRIAC must pass all tests before it is considered good.

To Test a TRIAC with the SCR250:

1. Connect the SCR250 TEST LEAD to the TRIAC as follows:

- Connect the Blue E-Z Hook® to the gate lead of the TRIAC.
- Connect the Black E-Z Hook® to the MT1 lead of the TRIAC.
- Connect the Red E-Z Hook® to the MT2 lead of the TRIAC.

WARNING

Be sure the test leads from the SCR250 are connected to the corresponding leads on the device under test. Incorrect lead connection can damage the device under test.

2. Press the POSITIVE GATE BIAS button on the SCR250.

3. Set the APPLIED VOLTAGE or LEAKAGE VOLTAGE switch on the Z-Meter to the rated working voltage of the TRIAC under test. If the rated voltage is not known, see the section on "Determining the Operating Voltage of an SCR or TRIAC" found in the Applications section of this manual.

4. Perform the "turn-on" test:

- Depress the GATE CURRENT button to the "ON" position.
- Press the Z-Meter LEAKAGE button. The display on the Z-Meter will overrange with flashing "888" for a good TRIAC indicating that the device is "turned on" and is conducting.

c. Press the NEGATIVE GATE BIAS button and repeat step 4b.

5. Perform the "leakage" test.

- Set the GATE CURRENT button to the "OFF" position.
- Press the Z-Meter LEAKAGE button. The display on the Z-Meter will show no leakage for a good device.
- Press the POSITIVE GATE BIAS button and repeat step 5b.

APPLICATION SECTION

SCR Operation

A Silicon Controlled Rectifier (SCR) is a three lead device that functions like a DC switch when given the proper control signal. An SCR has a cathode lead and an anode lead just like a standard rectifier. A third lead, called the gate lead, controls the operation of the SCR. An SCR functions like an open circuit when it is "turned off" and like a diode when the SCR is "turned on". This SCR action is controlled by the signal applied to the gate lead. Figure 4 shows the symbol used on schematics for an SCR. Notice that the symbol looks similar to a diode with the exception of the gate lead.

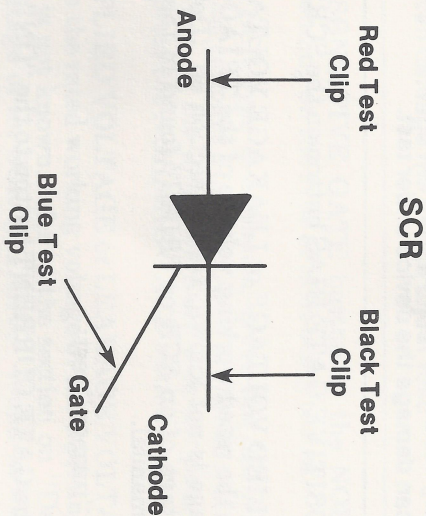

Fig. 4: Schematic symbol of an SCR with SCR250 test lead connections.

With no gate current applied to the gate lead, the SCR acts like a switch that is in the off position. One common failure of SCRs is the inability to completely shut off. The SCR may be either totally shorted or leaky. Some defective SCRs become leaky only when the voltage applied between the anode and the cathode is near the peak operating voltage and thus they must be tested at their operating voltage.

SCRs "turn on" when a small current is applied to their gate lead. A "turned on" SCR acts just like a diode, allowing current to flow in the forward direction only. In the reverse direction, no current flows. Another common failure in SCRs is a failure to "turn on."

SCR Types

SCRs come in a variety of sizes, shapes, current ratings, and voltage ratings. They can, however, all be classified into one of two types: Sensitive Gate and Normal Gate. Sensitive Gate SCRs get their name from the fact that they are very sensitive to the current applied to the gate lead. They are typically used in low current applications where only a small gate control current is available. Sensitive Gate SCRs come in a variety of physical shapes and sizes and can not be easily distinguished by simply looking at them.

For many applications, Sensitive Gate SCRs, are too sensitive for reliable use. Internal currents in the SCR, or small currents in the triggering circuits, may accidentally cause these SCRs to "turn on." Heat can also cause internal leakage currents to rise to the point of "turning-on" the SCR. To prevent SCRs from accidentally "turning-on", many of them have an internal bleeder resistance built into them. This bleeder resistance is placed between the gate and cathode lead as shown in figure 5. The resistance bleeds off any internal currents that might build up and prevents the SCR from accidentally "turning on" by itself. Due to the internal resistance, these SCRs require a higher external gate current to turn them on. In most applications, this additional gate current is easily obtainable, thus these SCRs have become more popular than the sensitive gate type and are called "normal or standard gate SCRs."

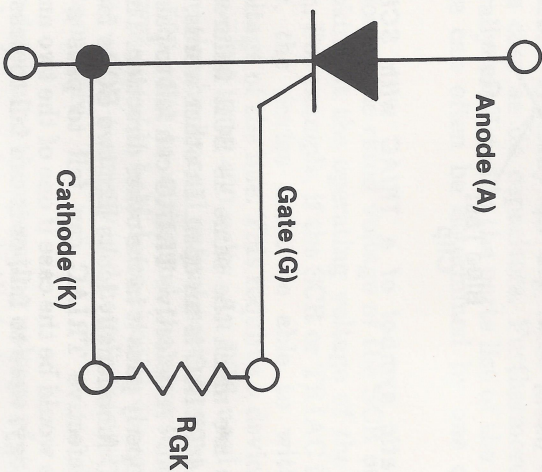

Fig. 5: Equivalent circuit of a normal gate SCR.

TRIAC Operation

A TRIAC is a bidirectional device similar in operation to an SCR except that it passes current in both directions when "turned on." Figure 6 shows the schematic symbol for a TRIAC. Note that the symbol resembles two diodes facing opposite directions. A TRIAC has three leads labeled: GATE, MT1 and MT2. The gate lead performs the same function as the gate lead on an SCR: it turns the device on. The other two leads are labeled differently from an SCR because the function of these leads change with the polarity of the voltage applied to the leads. The TRIAC lead electrically closest to the gate lead is simply called the Main Terminal 1 (MT1) lead, and the other lead is called the Main Terminal 2 (MT2) lead.

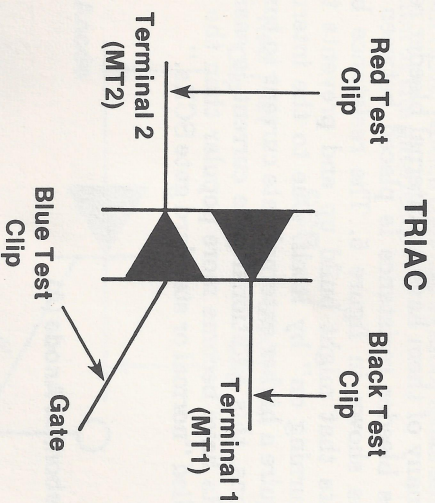

Fig. 6: Schematic symbol of a TRIAC with SCR250 test lead connections.

TRIAC failures are much the same as SCR failures. One common failure mode in a TRIAC is an open. In other words, the TRIAC can not be "turned on." A defective TRIAC can fail to pass current in one direction but properly pass it in the other direction. The reason for this is that a TRIAC functionally looks like two SCRs facing in opposite directions. A defective TRIAC can fail to pass a current in one direction only as would be the case if one of the two antiparallel SCRs, in the SCR analogy, were to fail, or it can fail to pass current in both directions.

Like SCRs, TRIACs can become leaky. A defective TRIAC can leak in one direction only or in both directions. Some TRIACs become "leaky" only when the full working voltage is applied to them.

Testing SCRs And TRIACs For Leakage

The leakage test for SCRs and TRIACs is done automatically when the GATE CURRENT switch on the SCR250 is in the "OFF" position. Any reading displayed on the Z-Meter while the LEAKAGE button is depressed is the leakage of the component under test. The leakage test is performed at the rated voltage of the device and gives a true indication of the leakage under normal operating voltages.

If you need a more critical leakage reading for SCRs, such as for those used in the high voltage shutdown circuits of TVs, place the LEAKAGE RANGE switch to the 100uA range. With the LEAKAGE RANGE switch in this position, leakage currents down to 1 microamp will be measured. The leakage in SCRs and TRIACs should not exceed 10 uA at room temperature. TRIACs will normally show slightly different leakage currents in each direction.

Some defective SCRs and TRIACs become leaky only when they become warm. If the SCR or TRIAC is suspected of being "thermal", in other words it drastically changes characteristics when it becomes warm, heat the component with a heat gun. A "thermal" SCR or TRIAC will show a rapid increase in leakage as it becomes warmer.

Determining Operating Voltage Of An SCR Or TRIAC

SCRs and TRIACs typically do not have their working voltage stamped on the case as do capacitors. Furthermore, their working voltage is generally not listed in the parts list of the instrument. The working voltage can often be determined by one of the following methods.

A good indication of the rated voltage of the SCR or TRIAC can be obtained by looking at the operating voltage of the circuit that the device is used in. For example, if the SCR or TRIAC is used to switch AC line power, the device must be able to withstand the full peak-to-peak voltage of the line. This requires a device having a rated working voltage of at least 400 volts. An SCR used in the regulator section in a television horizontal output section must have a rating of at least 400 to 500 volts to withstand the reverse voltage from the flyback. Small SCRs used in hold down circuits, for example, typically operate from a 24 volt B+ supply and usually have a working voltage rating of 50 volts or more.

The best way to determine the operating voltage of an SCR or TRIAC is to cross the device over to a substitute type using a substitution guide for semiconductors. The working voltage of the substitute SCR or TRIAC is equal to or higher than the working voltage of the device you are testing.

There are occasions when the SCR or TRIAC to be tested is not listed in a substitution guide and no circuit voltages are available. With the following procedure, you can test the SCR or TRIAC at a potential below that of its rated voltage without fear of damaging the device from applying too much voltage.

To test an SCR or TRIAC at a potential below its rated voltage:

- a. Set the APPLIED VOLTAGE switch on the Z-Meter to the 25 volt range. This is the lowest standard voltage range for SCRs and TRIACs.
- b. Test the SCR or TRIAC following the procedures given in the sections on "Testing SCRs" or on "Testing TRIACs".
- c. If the device does not test good when the "turn-on" test is performed, increase the applied voltage to the next standard voltage range. Standard working voltages for SCRs and TRIACs are 25, 50, 100, 200, . . . , 1000 volts in 100 volt increments.

SERVICE AND WARRANTY

Warranty

Your Sencore Test Equipment has been built to the highest quality standards in the industry. Each unit has been tested, aged under power for at least 24 hours, and then retested on every function and range to insure it met all published specifications after aging. Your instrument is fully protected in the unlikely event a manufacturing defect is missed by these tests. Details on the warranty are covered in the separate booklet. Read this booklet thoroughly, and keep it in a safe place so you can review it if questions arise later.

Service

The Sencore Factory Service Department provides all in- or out-of-warranty service and complete recalibration services for Sencore instruments. No local service centers are authorized to repair Sencore instruments. Factory service assures you of the highest quality work, the latest circuit improvements, and the fastest turnaround time possible because every technician specializes in Sencore instruments. Sencore's Service Department can usually repair your instrument and return it to you faster than a local facility servicing many brands of instruments, even when shipping time is included.

You do not need authorization to return an instrument to Sencore for service. Be sure you include your name and address along with a description of the symptoms if it should ever be necessary to return your instrument. Ship your instrument by United Parcel Service or air freight if possible. Use parcel post only when absolutely necessary.

Be sure the instrument is properly packed. Use the original shipping carton and all packing inserts whenever possible. If the original packing material is not available, make certain the unit is properly packed in a sturdy box with shock-absorbing material on all sides. Sencore suggests insuring the instrument for its full value in case it is lost or damaged in shipment.

A separate schematic and parts list is included if you wish to repair your own instrument. Parts may be ordered directly from the Factory Service Department. Any parts not shown in the parts list may be ordered by description.

We reserve the right to examine defective components before an in-warranty replacement is issued.

SENCORE FACTORY SERVICE

3200 Sencore Drive
Sioux Falls, SD 57107
(605) 339-0100
TWX: 910-660-0300

Fill in for your records:

Date Purchased:

7/27/87

Serial Number:

-000 601545/M

Run Number:

R11-000

(NOTE: Please refer to the run number if it is necessary to call the Service Dept. The run number may be updated when the unit has been returned for service.)