

## Answers To Common Questions On The SC61 Digital Readout

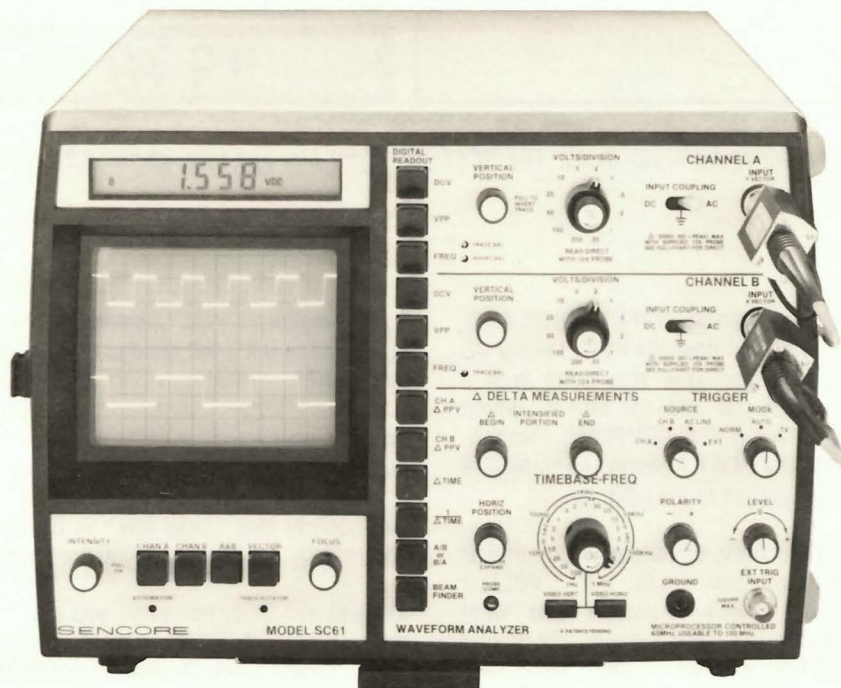

### 1. How can the digital readout and CRT work together, but still be so independent?

The CRT and the digital readout share a few circuits, and then separate into different paths. Both use the same probe, input connection, and input amplifiers. This lets you use a single probe to analyze any signal. The digital readings remain independent, however, because the signals are routed to the microprocessor before the CRT controls.

You don't even have to display the signal to make digital readings. If you do have the signal on the CRT, you can adjust the waveform the way you want it, without upsetting the digital readings.

This differs from other oscilloscopes that have digital readings. Most can only make measurements while a signal is displayed

This Tech Tip covers the most commonly asked questions about the SC61's digital readout. This should help you use the SC61 better, whether you've just started using the SC61, or whether you've used it for a long time and still haven't discovered some of its more subtle features. The questions are grouped by the type of readings, starting with a few general questions.

The SC61 Waveform Analyzer's digital readout was designed to bring digital accuracy to waveform analyzing. The digital readout provides the measurements needed to analyze the waveform on the CRT. However, the digital readings remain independent of the CRT controls, so that you can adjust the CRT just about any way you like without causing errors. No other oscilloscope with digital readings makes measurements in this way.

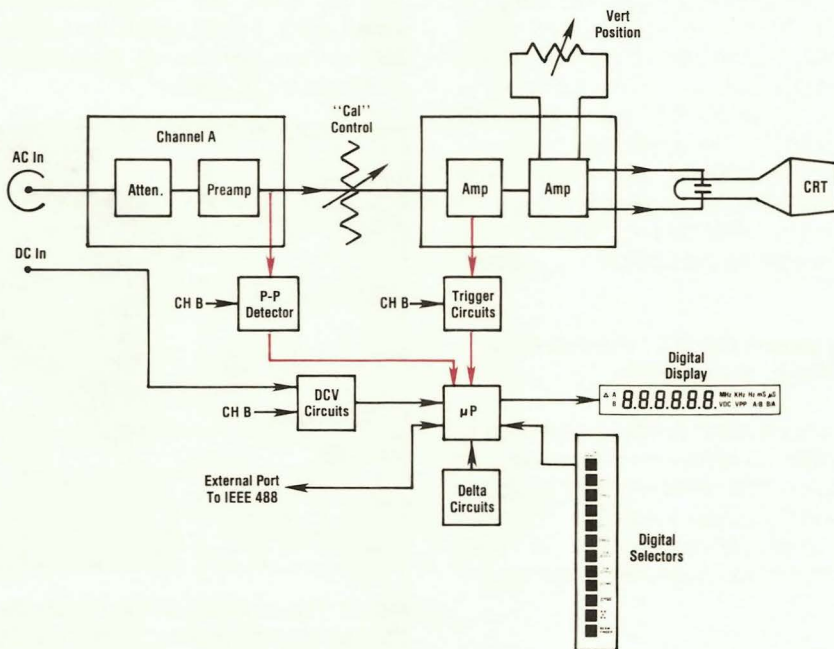

Fig. 1: The SC61 routes the measured signals to the digital measuring circuits ahead of the CRT controls to let you adjust the CRT anyway you like without causing measuring errors.

2 DCV measures bias.



3 VPP measures overall amplitude.



4 FREQ measures overall frequency.

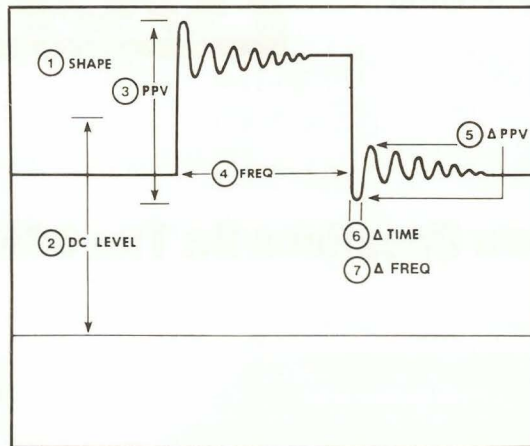

5 Δ PPV measures any part of the signal.



6 Δ TIME measures only time relationship.



7 Δ TIME gives equivalent frequency.



Fig. 2: You will have fully analyzed any signal after making these seven tests. The SC61 gives you test one through the CRT and the remaining tests with the digital display.

on the CRT. In addition, the readings are based on the CRT, requiring the vertical and horizontal controls to be in the "Cal" positions for accurate readings.

### 2. How did Sencore decide which tests to include?

Sencore designers simply looked at the steps needed to fully analyze any waveform. We found there were seven. Fig. 2 shows that these are: 1) Wave-shape, 2) DC bias, 3) Overall peak-to-peak voltage, 4) Overall frequency, 5) The peak-to-peak voltage of a part of the waveform, 6) The time relationship of any part of the signal, and 7) The frequency of a signal riding on the main signal. We determined that the waveshape could only be effectively analyzed with a high quality CRT. The other six parameters could be converted to digital readings. These are the tests provided by the SC61 digital readout.

### 3. Why doesn't the SC61 measure ohms, RMS voltage, or current?

These are voltmeter functions that have no relationship to analyzing a waveform. To add these tests would require additional probes and complex switching. The result would be complicated operation and costs much higher than a separate multimeter.

## DC Volts

4. Does the input have to be DC-coupled to take a DC voltage reading?

No, you can have the "INPUT COUPLING" switch set to any position while taking DC voltage readings. This was done with a separate path for the DC signal, which bypasses the "INPUT COUPLING" switch. DC enters the SC61 through the miniature banana jacks next to the main inputs.

The DC function is completely autoranged, so that you can leave the "VOLTS/DIVISION" switch anywhere you want while testing DC. This is especially helpful when testing a power supply for ripple. You can have the "VOLTS/DIVISION" switch set to a high sensitivity position to see the ripple while the DC function ranges up to read the DC level.

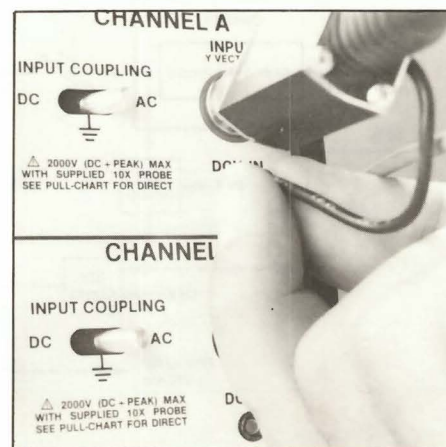

Fig. 3: The miniature banana connector on the low-capacity probes, supplied with the SC61, routes the DC signal around the Input Coupling switch, allowing you to measure DC voltage, even though the CRT input is AC-coupled or grounded.

### 5. Why is there a "DC" position on the input switch if it's not needed to make DC readings?

You still may want the CRT DC-coupled for some readings. For example, DC-coupling makes it easier to test logic circuits. You can confirm that "logic low" is below the correct level for the circuit you are testing.

Most of the time, however, you can leave the "INPUT COUPLING" switch set to its "AC" position, which eliminates adjusting the "VERT POSITION" control as the DC bias changes as you move your probe from one test point to the next.

### 6. Do I always have to use the low-capacity probes to measure DC?

The SC61 is supplied with two kinds of DC probes: the low-capacity probe with a DC path and the DC-only probe. The low-capacity probe is usually the easiest to use, since the single probe simultaneously feeds the DC and the CRT inputs. Certain applications can also use the separate DC-only probe; the 39G157. To use the 39G157, you unplug the miniature banana plug from one of the SC61 inputs. (You may leave the BNC-type probe jack connected.) Then, plug the 39G157 into the open banana jack. This lets you monitor DC at a third test point, while the low-capacity probes monitor the other two.

Always use the 39G157, rather than a probe from some other instrument. The 39G157 contains a 13.5 megohm range multiplier resistor. This resistor increases

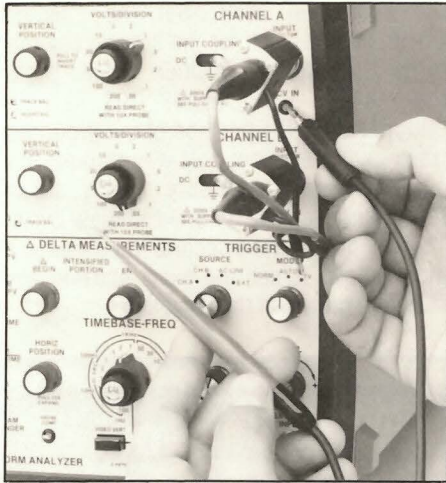

**Fig. 4:** You can use the 39G157 probe (included with the SC61) to measure DC voltages by connecting it in place of the small lead on the low-capacity probes. You can use the low-capacity probe for AC tests at the same time.

the DC input impedance of the SC61 to 15 megohms. It also provides correct decimal placement in the digital readings. Without the resistor, the input impedance would be only 1.5 megohms, and the digital readings would be ten times larger than the actual tested voltage.

The 15 megohm input provided by the 39G157 allows any of Sencore's standard meter accessories (such as the TP212 10 kV probe or the HP200 50 kV high voltage probe) to be used with the SC61. These

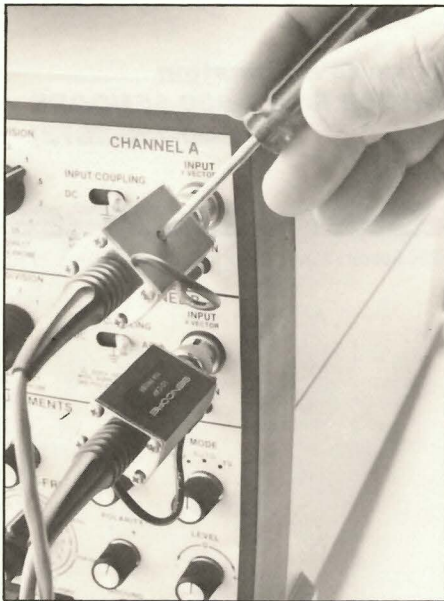

**Fig. 5:** The compensation capacitor in the probes must be properly adjusted for a square signal to ensure correct peak-to-peak readings. It is okay to use a metal screwdriver on the SC61 probes.

accessories only function correctly when matched to meter circuits of the correct impedance.

## Peak-To-Peak Volts

### 7. Which is more accurate, the CRT or the meter?

The CRT and digital readout may, at times, show slightly different peak-to-peak voltage readings. *The circuits for the digital readout are more accurate than any CRT-based circuits.* This doesn't even consider the added human errors, from parallax and interpolation, when using the CRT.

If you notice a sizable difference, check that your probes have been properly compensated. The instructions are on page 18 of the SC61 manual. The probe compensation adjustments affect the accuracy of both the CRT and the digital readout.

If the digital readout shows a higher value than the CRT, an extra signal may be present, which is not showing on the CRT. The digital circuits measure the full signal amplitude, even if the entire signal is not on the CRT. Increase the CRT intensity or slow the sweep rate to find the extra signal. The Delta PPV function can also help find the extra signal, as explained later.

### 8. Is the peak-to-peak function autoranged?

No, the peak-to-peak range is selected by the "VOLTS/DIVISION" switch for the channel you are using. There are four ranges, which change between any "2" and "5" setting of the "VOLTS/DIVISION" switch. You can tell the range has changed by watching the decimal in the digital display.

### 9. How is the Delta peak-to-peak different from the main function?

The Delta PPV function only measures peak-to-peak in the area of the CRT trace intensified by the Delta Bar. This lets you select the part of the waveform you want to measure. For example, you can measure the noise on the top of a square wave by adjusting the intensified area to cover only the top part. You can also use the Delta function to find which part of a waveform contains extra noise or spikes. Start with a small intensified area. Watch the digital reading as you widen the area. You have found the noise when you see a sudden increase in the peak-to-peak voltage reading.

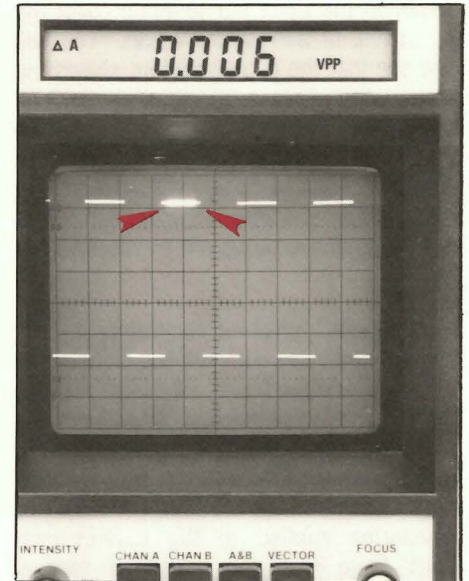

**Fig. 6:** The Delta PPV function only measures the amplitude of the waveform covered with the intensified Delta Bar. Here, the Delta function shows the amount of noise riding on the top of the square wave.

### 10. Is there anything special I must do to get accurate Delta readings on video signals?

You must have the SC61 in its video sync mode. This enables several special video circuits needed to correctly measure composite video signals. There are two ways to select video sync: 1) Use the "TV" position of the TRIGGER MODE switch, or 2) Use the "Video Preset" buttons. The "Video Preset" buttons operate when the "TIMEBASE-FREQ" switch is pointing straight down.

The SC61 video sync circuits remove vertical sync when making measurements on signals at the horizontal rate. Here's why this is important. See Fig. 7 for details.

A conventional oscilloscope allows the vertical sync to come through at random when viewing horizontal waveforms. This causes all Delta PPV readings to be referenced to the sync level. When the SC61 blocks vertical sync, you can measure signals which are not referenced to sync. The color burst, for example, is not referenced to sync, so the sync pulse must be blocked to get an accurate reading of its amplitude. You would also need to block sync to measure a luminance signal. The SC61 does all of the sync blocking automatically. All you need to do is select one of the TV trigger modes and the correct trigger polarity.

## Frequency

### 11. Why are the frequency readings more stable than a frequency counter?

Most frequency readings are made through the CRT triggering circuits. The trace tells you when the circuits are properly adjusted, so that you can adjust them to ignore noise which causes random readings on conventional counters. But, that's only the beginning of the story. The SC61 actually uses two frequency counting signal paths. These paths are not divided between input channels, as you might guess. Rather, there is a "main" and an "auxiliary" path. The path used depends on how you have triggered the CRT.

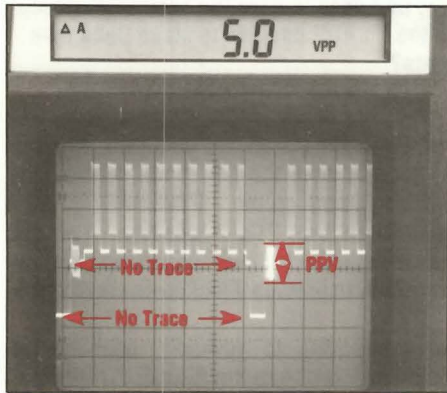
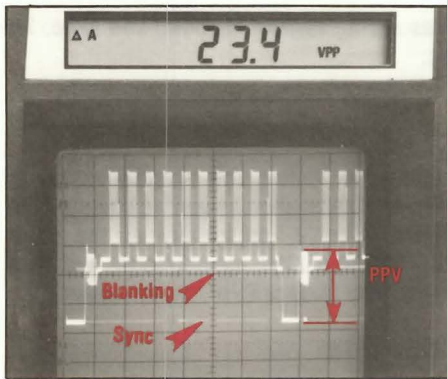

**Fig. 7:** The sync separators eliminate Delta PPV errors caused by vertical sync adding to a reading. If sync comes through (top) all Delta readings would include sync. By blocking sync (bottom) only the color burst is measured.

The main counting path gets its signal from the CRT triggering circuits. For example, if you are triggering the CRT from Channel A, pressing the Channel A "FREQ" pushbutton selects the main counting path. When you move the TRIGGER SOURCE switch to the "CH B" position, pressing the Channel B "FREQ" pushbutton selects the main path.

The main path provides stable frequency readings when the CRT is triggered

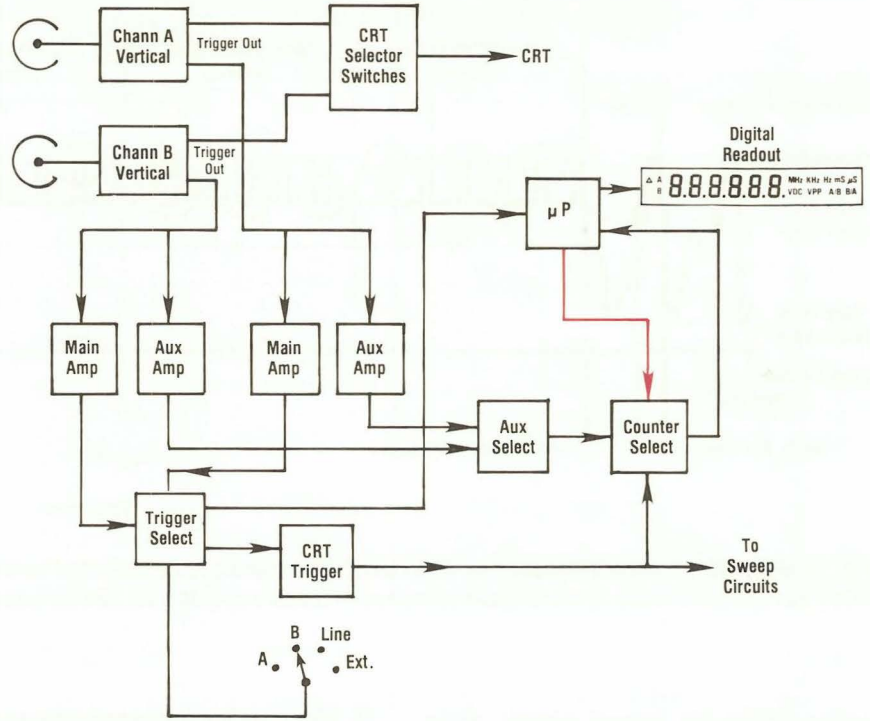

**Fig. 8:** The microprocessor automatically picks up signals from the main or the auxiliary counter path to allow measuring the frequencies of two unrelated signals.

correctly. This also means that the main channel *might not count correctly* if the CRT is not properly locked.

The SC61 uses the second, auxiliary, counter path any time you press the "FREQ" button for the channel *not used for triggering* the CRT. This path works like the input circuits of a deluxe frequency counter. It includes automatic centering and balancing of the input threshold. A big advantage over conventional counters, however, is that the auxiliary path measures a much wider range of signal levels, from 5 millivolts all the way to 2000 volts.

The CRT also serves as a level indicator for the auxiliary path. The signal should be larger than 1.5 CRT divisions for reliable results. If the counter is erratic or seems to mis-count, check the CRT (the signal doesn't need to be triggered). Adjust the "VOLTS/DIVISION" switch until the signal is at least 1.5 divisions tall.

Just like a separate frequency counter, the auxiliary path may count signal noise if it has enough amplitude. You can usually eliminate the noise by *reducing the gain* of the channel containing the signal, using the "VOLTS/DIVISION" switch. If the noise still causes trouble, use the main counter path (trigger from the channel you

want to measure) and adjust the TRIGGER LEVEL control or switch in the TV sync separators to clean up the signal. Use the CRT as your guide for correct adjustment of the triggering circuits.

### 12. When testing video signals, why does the SC61 sometimes show the right frequency and sometimes the wrong frequency?

Composite video signals are nearly impossible to count with a conventional frequency counter, because they are made of many different signals. The SC61 has special circuits to make it possible to count sync frequencies in most instances. You must, however, use the main counter channel and have the CRT properly triggered. You must tell the frequency circuits whether you want to count the vertical or the horizontal sync frequency by setting the CRT to display waveforms at the vertical or at the horizontal rate.

The SC61 needs additional circuits to correctly count interlaced sync. The nine horizontal lines near vertical serration and horizontal equalizing pulses. These pulses occur at twice the rate of horizontal sync. This causes a frequency counter to read too high. The SC61 has circuits which block the 30 kHz

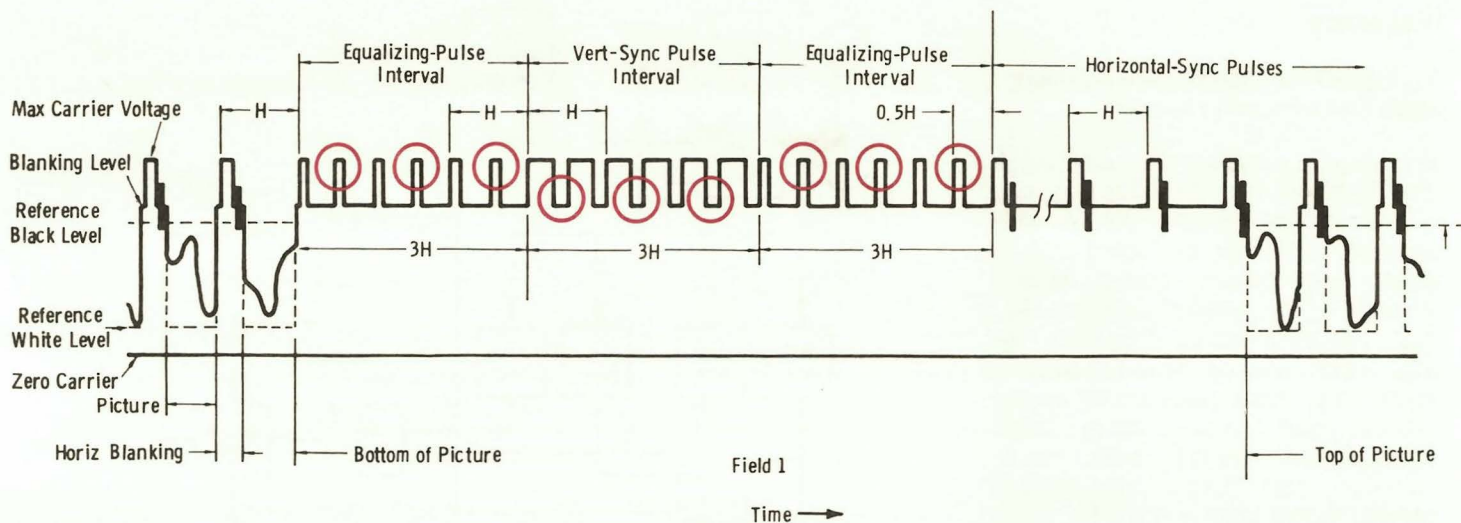

**Fig. 9:** Measuring correct frequency on interlaced video signals is complicated by the extra pulses during vertical blanking and sync. The SC61 has special circuits to block these pulses and measure only the 15,734 Hz horizontal pulses.

pulses during the vertical interval, while counting the 15 kHz sync pulses.

When properly triggered on an interlaced signal, the SC61 frequency function will show the correct vertical frequency of 59.94 Hz and the horizontal frequency of 15.734 kHz.

Color bar generators, computers, and low-cost cameras often produce non-interlaced signals. If so, the SC61 will appear to measure the horizontal frequency too low. This happens because non-interlaced video signals do not have serration pulses during the vertical sync pulse. This causes the horizontal frequency to read low, because 3 pulses are missing out of every 262 pulses.

The vertical sync frequency for a non-interlaced signal typically shows a frequency of 60.05 Hz, compared to 59.94 Hz for interlaced sync. *This is the correct frequency for a non-interlaced signal.* The difference results because each vertical field contains only 262 horizontal lines, which is one-half line less than an interlaced signal.

**13. What does the frequency ratio test actually do?**

This function calculates the ratio of the two frequencies applied to the inputs. Its main use is testing frequency multiplier and divider circuits. The SC61 readout shows the ratio, along with an indication of which frequency is higher. A display of "A/B" tells you that Channel A has the higher frequency, while "B/A" indicates that Channel B is higher.

**14. Why does the frequency ratio test take longer than other functions?**

The SC61 must take a frequency measurement from each channel before the microprocessor can calculate the ratio. The actual time needed depends on the two frequencies involved, since the autoranging circuits need a longer time to measure frequencies below 10 Hz.

If the frequency in either channel changes, you normally need to wait for the next pair of updates to see the resulting change in the ratio. You can speed this process

slightly by forcing the microprocessor to re-calculate as soon as you've changed the signal. Simply, press any of the other DIGITAL READOUT pushbuttons, and then press the "A/B or B/A" button again.

**Delta Time**

**15. Do I need to have the horizontal sweep in the "CAL" position to make Delta time tests?**

No, Delta Time is always accurate, whether or not you have the horizontal vernier (the variable knob of the "TIMEBASE-FREQ" switch) in the "Cal" position. You do, however, need to have the sweep properly triggered to provide a locked-in waveform.

To prove this to yourself, connect the Channel A probe to the PROBE COMP jack. Adjust the vertical and horizontal circuits until the square wave appears on the CRT. Set the horizontal vernier to the "Cal" position by rotating the knob fully clockwise. Then press the Delta Time button and adjust the Delta Begin and Delta End controls until the intensified area just covers the top of the square wave.

Next, move the horizontal vernier out of its "Cal" position. You will notice that intensified Delta Bar stays the same relative size on the CRT trace. As you continue to turn the vernier (allowing more and more cycles to appear on the CRT) the intensified area will cover more and more cycles of the signal. When you stop rotating the control, and let the digital readout settle, the number will now show a longer time reading.

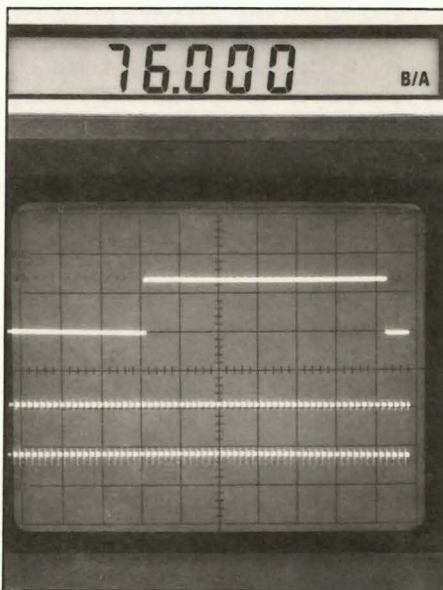
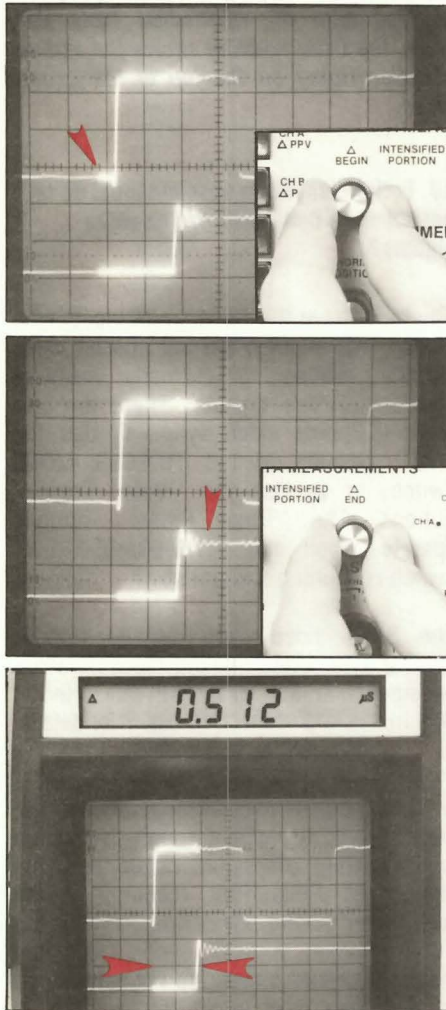

**Fig. 10:** The Frequency Ratio test calculates the ratio of the two input frequencies and indicates the higher frequency by means of the "A/B" or "B/A" indicator.

Re-adjust the Delta Bar to again cover the top of one of the square waves. You will now see that the digital readout shows the same time (within a few counts) as when the vernier was in the "Cal" position. The slight difference between the readings simply shows how closely you were able to interpret the starting and stopping points on the signal each time you re-set the Delta Bar.

#### 16. Why does Delta time accurately measure the delay between two signals?

The Delta Time readings are referenced to a high-accuracy crystal. They are just as accurate when measuring the time within a single waveform, or the time between two waveforms applied to the dual-channel input. Page 37 of the instruction manual explains how to make the test of the delay between two signals.



**Fig. 11:** Three steps let you measure the time between two signals: 1) Set the Delta Bar beginning to the transition in the first signal. 2) Set the Delta Bar end to the transition in the second trace. 3) Read the digital display.

The procedure consists of three steps: 1) Adjust the *beginning of the Delta Bar* until it touches the transition in the *first* waveform, 2) Adjust the *end of the Delta Bar* until it touches the transition in the *second* waveform, and 3) Read the digital readout. The digital display shows the time delay between the two marked points.

This works because the intensified Delta Bar has *exactly the same starting point* in both CRT traces. It also has *exactly the same length* in both traces. Adjusting the intensified area for the *difference* between the two signals produces a digital reading of the signal delay.

#### 17. Why do I get a different frequency reading when I use the frequency function compared to the Delta function?

They read differently because one function actually counts the frequency, while the other calculates it based on your interpretation of the signal. Each function, however, lets you measure signals that you cannot easily measure with the other function.

The "FREQ" function is a true frequency counter. It digitally counts the incoming signal to crystal accuracy. This measurement will *always* be the more accurate of the two SC61 frequency methods. The limitation of the "FREQ" function, however, is that it only measures the overall frequency. It cannot be used to determine the frequency of a signal buried down inside another signal, such is often the case with interference. Only the SC61 Delta test (or calculations using a conventional scope) lets you determine frequency, in this case.

The 1/Delta-Time function gives an equivalent frequency based on the time for one complete cycle of the signal. This is the same method used to calculate frequency with any good oscilloscope. The SC61 offers better accuracy than a scope, since the intensified Delta Bar is part of the waveform itself. This eliminates parallax errors and reduces other kinds of interpretation errors.

The accuracy of the reading, however, depends on how closely you have adjusted the length of the intensified zone. A slight error in setting the zone causes different frequency readings.

You can improve your accuracy with a simple technique. Use the second SC61 trace to help set the beginning and end of

the intensified zone. Set the "INPUT COUPLING" switch for the second channel to its "Grounded" position. Then, press the "A&B" (dual trace) CRT selector button. Adjust the position of the grounded trace until it is about half way through the signal you want to measure. Finally, adjust the intensified zone for one complete cycle. You will find that the second trace makes it much easier to see the exact starting and stopping points on the waveform.

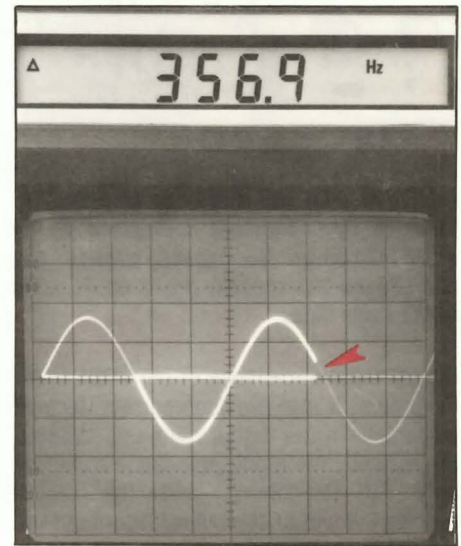

**Fig. 12:** When making "1/Delta Time" readings, you can set the second trace to the "ground" position and then use it to help set the beginning and end of the Delta Bar. This helps mark one complete cycle more accurately.

**For more information  
Call Toll Free 1-800-SENCORE  
(1-800-736-2673)**

**SENCORE**

3200 Sencore Drive Sioux Falls, South Dakota 57107