

## Analyzing The Horizontal Output Pulse With The Waveform Analyzer

Of all the TV waveforms you have to analyze, the horizontal output transistor collector pulse is the most important because this output pulse is used to perform many other functions than to just sweep the CRT beam horizontally. It can easily be said that the horizontal output transistor is the heart of a TV. Let's take a careful look at nine of the key functions this all-important horizontal output waveform is responsible for, how to fully analyze it, and some possible problems.

The horizontal output stage is practically responsible for the complete and efficient operation of the entire TV. The waveform at the collector of the horizontal output

transistor is the most important waveform you should check on every TV before you begin changing parts, and after every TV is repaired.

### Looking At The Horizontal Output Pulse With In Three Simple Steps

Sencore's Waveform Analyzers use a highly accurate low capacity probe network that lets you safely measure the horizontal output transistor and other pulse waveforms to 2,000 volts (DC + peak AC). Even if you should happen to accidentally leave your Waveform Analyzer input attenuator in its most

sensitive position and hook up to the horizontal output transistor collector, there is no need to panic as no damage will result.

1) Connect the TV AC line to an isolation transformer, such as the Sencore PR57 POWERITE®. The isolation transformer protects you and your equipment from electrical shock and damage by isolating the HOT chassis from you and your Waveform Analyzer.

2) Hook up the probe ground to the TV chassis ground, then connect the probe to the collector of the horizontal output transistor.

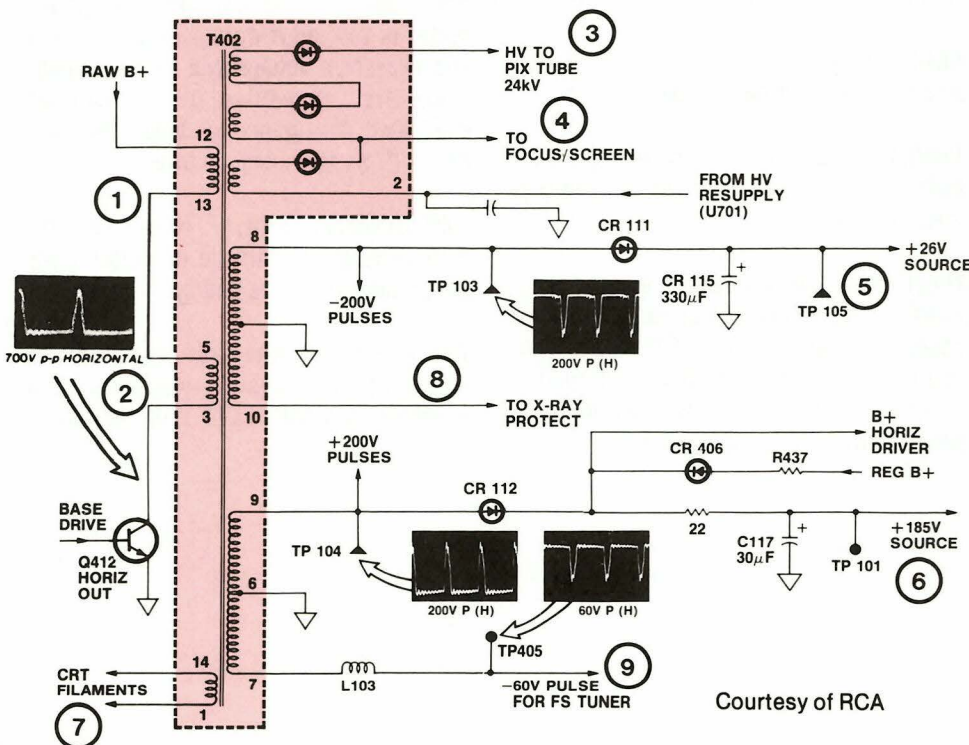

- ① .7 amps horizontal deflection.
- ② 700 to 1,500 volts P-P retrace power.
- ③ 15,000 to 30,000 high voltage.
- ④ 3,000 to 8,000 focus voltage.
- ⑤ 16 to 30 volts high current DC.
- ⑥ 185 to 220 volts low current DC.
- ⑦ 6.3 volts pulse CRT filament power.
- ⑧ Safety protection source.
- ⑨ 60 volts pulse to operate tuner.

Courtesy of RCA

Fig. 1: The horizontal output pulse is responsible for the efficient operation of the TV.

3) Adjust the vertical volts per division control to the 200 volts position. Switch your time base control all the way down to the video preset position. Push in the horizontal preset button and you will see waveforms that include two lines of video information.

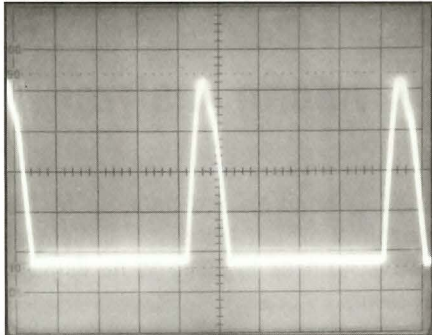

Fig. 2: A typical horizontal output pulse.

### What To Look For In This Waveform

Before you do any measurements, take a second or two to look over the waveform itself. It should look just like the horizontal waveform in Figure 2. The waveform should be symmetrical in shape during pulse retrace time. If it is not, look for a change in the value of the horizontal output transistor stage timing capacitors, or an excessive load on a B<sup>+</sup> supply. The waveform should be symmetrical before you proceed with testing .

The trace or scanning “on time” of the transistor should also be relatively clean. Any excessive ringing is a clear indicator of deflection system problems such as a cracked integrated high voltage transformer (IHVT) core or open IHVT windings. The trace must be clean before you analyze the pulse any further. If it is not, look for other noise pulses riding along during the trace time. They could be causing faint noises or drive

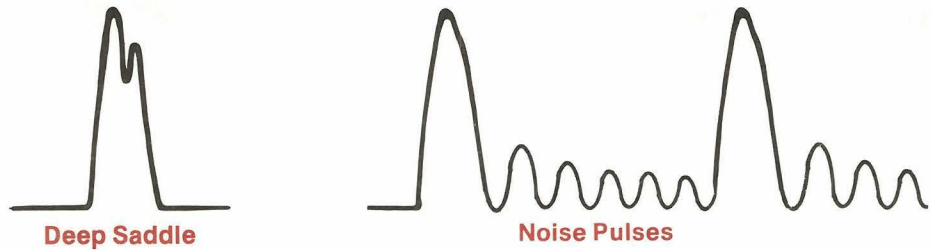

Fig. 3: Two common faulty waveforms which cause problems with the operation of a TV.

lines in the video picture. Look for a shorted secondary power diode, shorted IHVT diodes or shorted windings. The trace time should be clean of any noise before performing the measurements to follow .

### Measuring The Waveform Parameters (Automatically)

You’ll need to make four measurements (along with the waveshape covered earlier) of the horizontal output waveform to be sure that it is operating safely or when you are troubleshooting the horizontal section of the TV:

**FIRST:** Push the DCV button for fully autoranged DV voltage measurements.

**SECOND:** Push the VPP button for automatic peak-to-peak measurements.

**THIRD:** Push the FREQ button for automatic and noise free frequency measurements.

These three measurements are the first ones to be made. They tell you the condition of the regulated B<sup>+</sup> supply, and that the TV is not in the shut-down mode. The next measurement is used to help prevent future component failures.

### How Important Is The Duration Measurement Of The Horizontal Output Transistor Waveform?

Of all the horizontal output transistor waveform parameters, the “duty-cycle” measurement tells you the most. Because of the many jobs that this critical circuit performs, TV manufacturers carefully specify the horizontal output transistor “duty-cycle” or time duration in exact microseconds as follows:

**Retrace time:** 11.5 - 16 microseconds

**Trace time:** 47.5 - 52 microseconds

They make these specifications for a very good reason. If the time duration (duty-cycle) is too short during retrace, speed and excessive voltage will be developed; therefore, excessive power will be dissipated. This generates heat which will cause TV parts damage in time.

**IMPORTANT:** Always refer to the manufacturers’ schematic or literature for the particular chassis timing.

The Waveform Analyzer is especially equipped to measure portions of a waveform with the DELTA TIME feature.

### To make this important measurement:

1. Align the pulse by using the VOLTS/DIVISION and the CAL. knobs so the top of the retrace pulse is on the 100% graticule marking.
2. Select the dual channel mode by pushing the A & B button.
3. Switch the CHANNEL B INPUT COUPLING switch to ground, and align the trace with the VERTICAL POSITION control so it lies on the 10% graticule marking.
4. Press the DELTA TIME button,
5. Adjust the DELTA BEGIN knob so the left-side of the intensified trace aligns with the left-side intersection of the CHANNEL A and CHANNEL B traces (Figure 4).

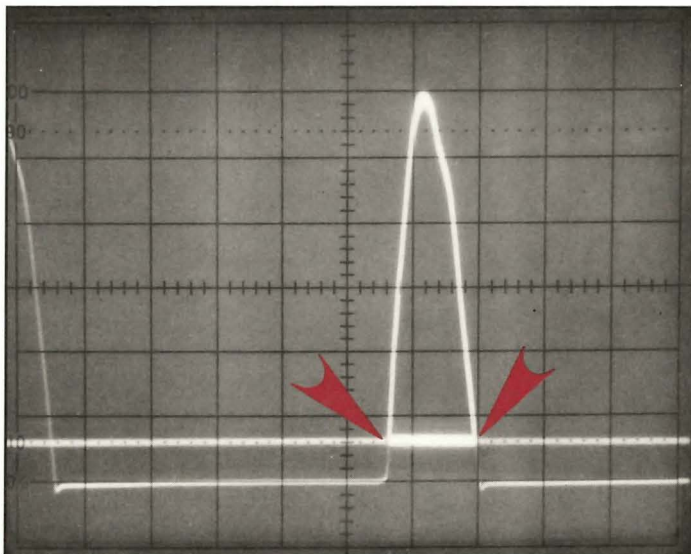

**Fig. 4:** The time duration measurement of the retrace pulse should be made from the 10% to 10% levels.

6. Adjust the DELTA END knob to align the right-side of the intensified trace with the right-side intersection of the two traces.
7. Read the digital display directly in microseconds to see that you are within 11.5 to 16 microseconds .



**Fig. 5:** The digital display shows the timing.

### What If The Horizontal Output Was Only 5 Microseconds Off?

Suppose you measure 9 microseconds instead of 14 microseconds for the retrace pulse. On a TV with this type of problem, the peak-to-peak value could be good, the DC reading could be close, and the waveform would look close enough. Even the frequency could be right on 15,734 Hz. This TV will work for a while.

Shifting the retrace duty cycle 5 microseconds does not look like much, or even sound like much. But, to the horizontal output system, it sees a 35.7% reduction in retrace time meaning that retrace is faster and this generates higher voltage that means the horizontal output transistor is "on" just a little longer at full scan conduction. Increased conduction time means increased heat.

Increased scan time means increased scan derived power supply levels. The power supply capacitors have a longer time to charge and reach higher voltages. All the circuits are now stressed and must work at this higher voltage.

### Isolate Start-up and Shut-Down Problems With The Horizontal Output Pulse

The CRT can be used to watch for an instantaneous start-up pulse. Simply connect the Waveform Analyzer and preset the CRT controls as described earlier. Then, watch the CRT as you apply power to the TV's circuitry. If you see a pulse appear then disappear your start-up circuitry is operating correctly and the set is in the shut-down mode.

If this happens, you have to service the chassis in a "powered down" condition., at either half the normal B<sup>+</sup> level, supplied separately, or reduce the AC input power to half power (60 VAC) and monitor the collector of the horizontal output transistor with your scope.

*NOTE: If the chassis uses a switch mode power supply (SMPS) as the B<sup>+</sup> source, you need to determine if the SMPS is defective, or if the problem is on the horizontal output stage. Refer to Tech Tip #205 "Identify SMPS Problems" for information on how to do this.*

**For More Information,  
Call Toll Free 1-800-SENCORE  
(1-800-736-2673)**

**SENCORE**

3200 Sencore Drive, Sioux Falls, SD 57107

**8LL#**

**#118**

**#118**

**8LL#**

**8LL#**

**#118**