

# SENCORE®

Means Success In Electronic Servicing

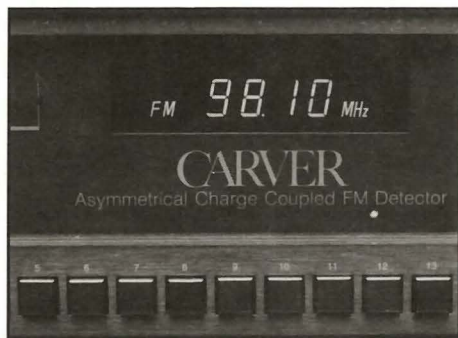
# tech tips

## Using the SG80 with Modern FM Receivers

Improvements in FM receiver technology call for updated testing methods. This Tech Tip covers the most recent circuit innovations, and how to confirm they work correctly.

### Digital Tuning

Until recently, digital tuning was only found on the most expensive receivers. Now, the lower cost of digital tuning brings this feature to most receivers. The tuners normally display the frequency of the selected channel, and may also allow the user to store from 5 to 30 channel frequencies in memory for recall at the push of a button.



**Fig. 1:** Since the readout of a digitally tuned FM receiver does not test frequency directly, it may display a frequency, even though the receiver is tuned to a different channel or is totally inoperative.

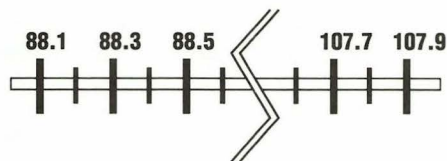
The digital readout shows the frequency the microprocessor intends the front end to tune, rather than actually measuring the frequency of the front end's local oscillator. Therefore, the receiver might not tune to the indicated frequency. When problems develop, the receiver may tune to a different frequency, or may not tune at all.

Use the SG80's ability to tune both "on-channel" and "inter-channel" (between

channel) frequencies to confirm the digital tuner works correctly. The frequency, accuracy, and stability of the SG80 exceeds the specifications of the best receivers. This eliminates the dependence on over-the-air tests for accuracy confirmation, which is common when using generators with less accuracy.

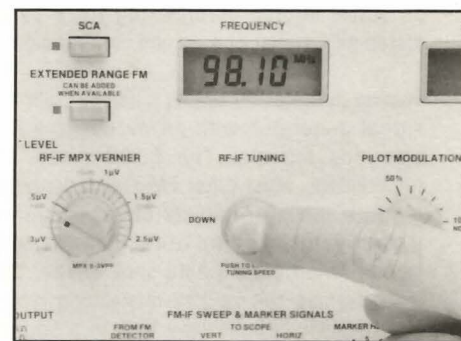
Normal channel steps fall at odd decimals of the FM band, starting at 88.1 MHz. Each following channel is 200 kHz higher in frequency; 88.3, 88.5, 88.7, etc. The SG80 has two tuning speeds, depending on whether you need "on-channel" or "inter-channel" tuning.

In normal tuning the generator steps in standard 200 kHz intervals. When you want "inter-channel" tuning, simply press the spring-loaded tuning knob to change the tuning speed. The generator then moves in 10 kHz steps.

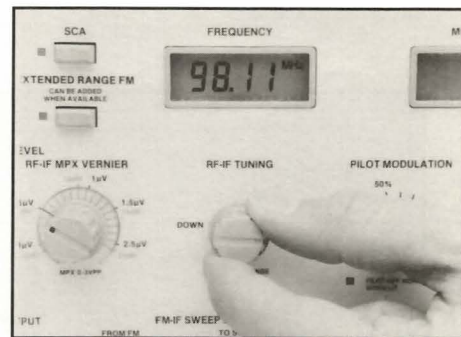


**Fig. 2:** FM channels are spaced every 200 kHz at the odd decimals starting at 88.1 MHz. The SG80 produces channel by channel tuning in its normal tuning mode.

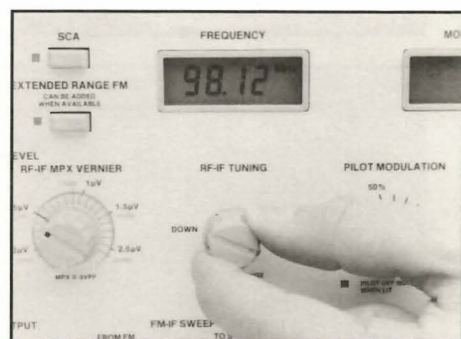
Monitor the receiver's output on meters or an oscilloscope as you tune between the channel steps. A properly operating receiver should provide its best output when the generator is set to an exact "on-channel" frequency. Test the receiver by setting it and the SG80 to the same channel frequency (for example 91.7 MHz). Then, without changing the setting of the receiver, shift the SG80 off-channel in either direction. If the output is better with the shifted frequency than the on-channel frequency, the automatic fine tuning (AFT) circuits should be repaired.



a



b



c

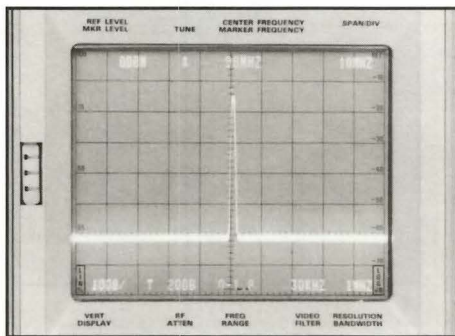
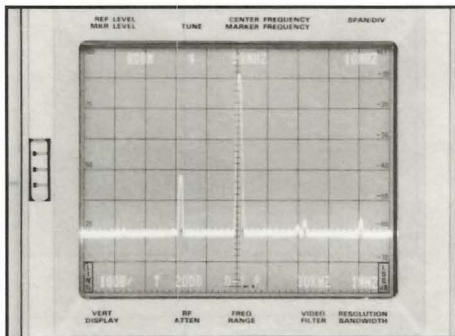
**Fig. 3:** Pressing the tuning knob changes the SG80 to "inter-channel" tuning to let you move the generator to frequencies between channels. The receiver should produce its best output when tuned to the normal channel frequency.

The digital circuits should tune the AM channels in a similar manner. The audio should have its best quality when the generator is set on-channel. If the output improves as the frequency is shifted off-channel, the tuning circuits need service.

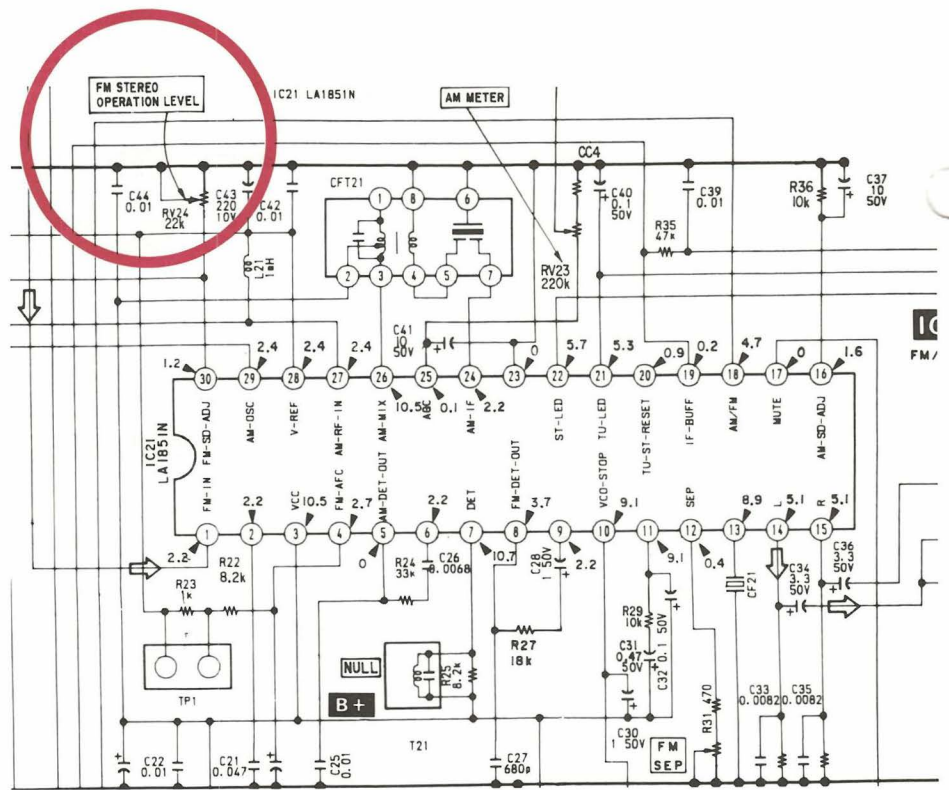
## Auto-Search Tuning

Many digitally tuned receivers have circuits that automatically search out local stations at the press of a button. These circuits normally scan through RF frequencies, looking for an RF signal larger than a preset threshold level. Some receivers also confirm the presence of an active station by checking for a 19 kHz stereo pilot signal as a second confirmation.

Testing auto-search tuning systems calls for a signal generator with an output free from spurious signals. The SG80 meets this requirement. Most other FM signal generators produce mixing products or other spurious signals larger in amplitude than the tuned signal. When testing auto-seek tuning, these extra signals can lead to misleading results. The receiver circuits may lock to a spurious signal instead of the tuned signal, leading to the conclusion that the receiver's auto-seek circuit is defective.



**Fig. 4:** As this spectrum analyzer test shows, other FM generators (top) produce spurious emissions which make testing of auto-seek circuits difficult. The receiver triggers on the added signals instead of the main carrier. The SG80's output (bottom) produces only one signal at the correct carrier frequency.



Courtesy: Sony

**Fig. 5:** The auto-seek circuits must be adjusted to the correct threshold for reliable operation.

The SG80's highly filtered output produces only one signal. If the auto-seek circuits stop before reaching the tuned frequency, one of three things has happened: 1. An over-the-air signal is finding its way into the front end, 2. The receiver's auto-seek circuits are too sensitive, and triggering on noise, or 3. The auto-seek circuits are defective.

In the first case, you will need to determine whether off-the-air signals are large enough to cause problems. Most receivers let strong signals enter through the RF or mixer stage shields. If you are near a powerful transmitter, it is normal for the receiver to stop at those frequencies.

If strong local signals cause problems, perform your tests at a frequency in the FM band with the fewest interfering over-the-air stations. Or, consider a shielded test area, which blocks all over-the-air signals. You may wish to build or purchase a shielded box large enough to cover the test equipment and the receiver under test. In the other two cases, the receiver needs service. An internal adjustment often corrects problems related to locking to noise. The threshold detector may be defective if the receiver fails to lock to a normal signal.

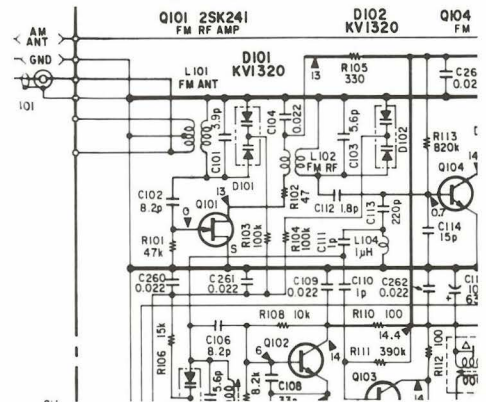
## High Gain RF Amplifiers

Modern receivers use amplifiers with high gain and low internal noise to achieve best

sensitivity. While gain and noise relate closely, they are two different factors which determine the ability to pick up small antenna signals. The standard 50 dB quieting sensitivity test checks both simultaneously to determine receiver performance.

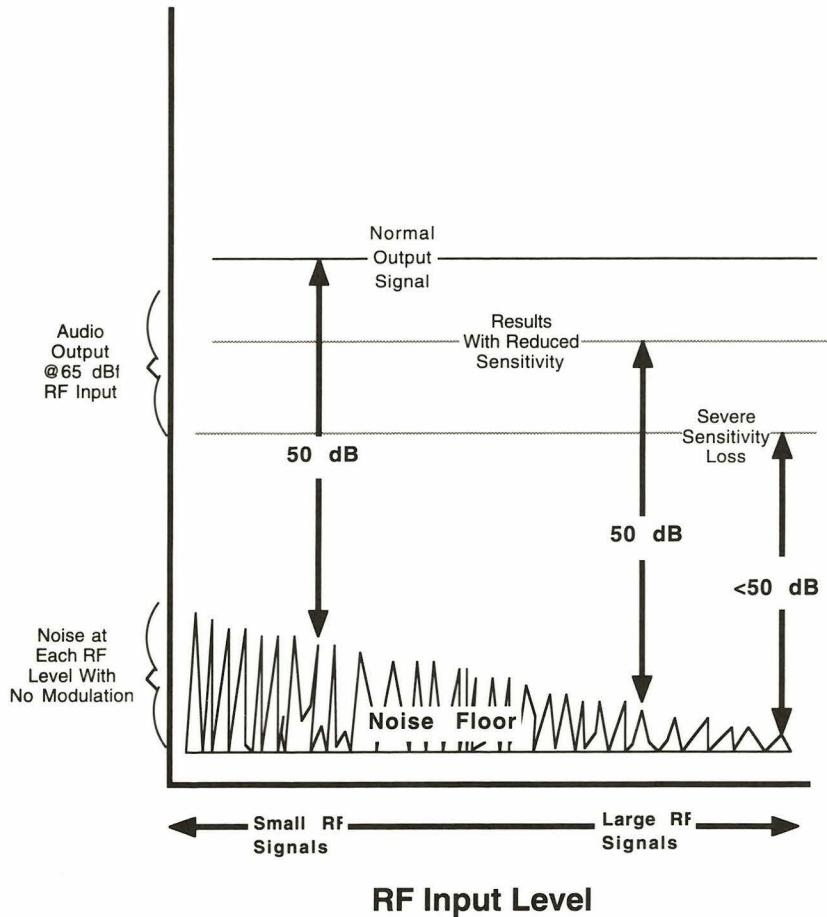
The use of field effect transistors (FETs) in the RF amplifier has greatly improved the sensitivity of FM receivers. Most front-ends use dual-gate FETs, where one input receives the RF signal, and the second receives a control voltage used to regulate gain.

A receiver with a defective RF amplifier might seem to work when testing with over-the-air signals. RF amplifier problems often allow the



**Fig. 6:** The high gain and the low noise of the FET RF amplifier provides good sensitivity on weak signals. The standard "50 dB quieting test" checks both gain and noise to confirm the receiver has normal sensitivity.

# FM Sensitivity Using 50 db Quieting



**Fig. 7: The 50 dB quieting test finds the RF signal needed to place the “noise floor” 50 decibels below a fully modulated signal. If the receiver has problems, an RF signal which is much larger than normal is needed.**

receiver to pick up stronger signals. Only stations with weaker signals are distorted or missing. Often, the “strong” station at the location of your business is a “weak” station at your customer’s location, leading to the problem of a receiver that tests okay when you test it, but performs poorly when your customer gets it home.

To prevent this type of phantom problem, perform the standard 50 dB quieting sensitivity test each time a receiver crosses your bench. This will pinpoint reduced gain immediately.

## Low Noise Front Ends

Gain is only one factor that makes it possible to tune distant stations. The second factor is how much noise is created in the receiver’s circuits. The 50 dB quieting test measures the effects of both gain and noise in testing the quality of an FM receiver.

The first two receiver stages play the biggest role in noise. Components in the RF amplifier and the mixer generate random noise. The noise often increases if a component develops leakage. If the noise becomes too large, it begins to mask weaker signals.

That’s why the standard 50 dB quieting sensitivity test considers both gain and noise in determining receiver sensitivity. If high RF levels are needed to overcome the noise (or the ratio always stays less than 50 dB), you know the receiver circuits are generating too much noise, and are not working correctly.

## Multiple Bandwidth IF Amplifiers

The large number of FM stations in many areas creates problems for listeners who want to tune to a station with a weak RF level. Stronger signals “capture” the detector, making it difficult to select the desired station.

An intermediate frequency (IF) amplifier with narrower bandwidth can reduce this problem. The sharper selectivity rejects the strong, interfering signal, but also reduces fidelity.

The fidelity reduction occurs because the width of the FM channel (the amount the carrier moves from the center channel frequency) represents the loudness of the signal. Only the loudest modulation uses the full channel bandwidth.

Hence, narrowing the IF bandwidth to improve selectivity, does not affect quiet signals, but causes clipping on the loudest program signals.

Some clipping is acceptable if it is the only way to reject unwanted signals. When there is no interfering channel, the clipping of the narrowed IF bandwidth is not desirable.

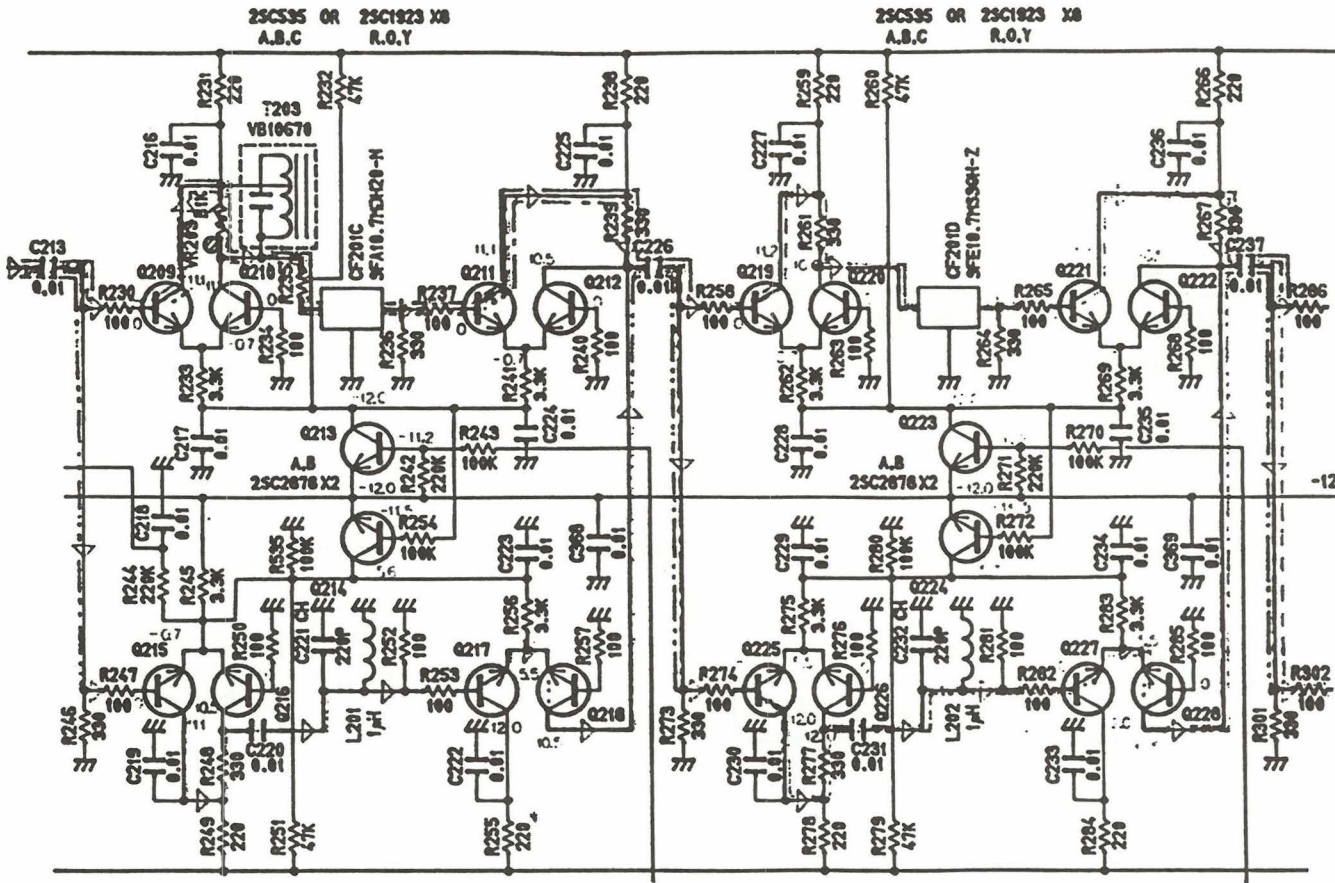
Many top-of-the-line FM receivers let the user select from several IF bandwidths. When there are no adjacent signals, setting the IF stages for maximum bandwidth produces highest fidelity. When reception is difficult, narrowed IF bandwidth improves performance with some reduction in audio quality.

The schematic in Fig. 9 shows how a selectable IF stage uses a combination of fixed-tuned, ceramic IF filters and tuneable L/C tank circuits. Normally, the ceramic filters establish the widest bandwidth. When the user narrows the bandwidth, the other filters parallel the ceramic filters to increase the Q.

Servicing these stages, calls for a combination of techniques. The ceramic filters need a generator with an adjustable center frequency, since the filters may be tuned to a frequency other than 10.7 MHz. The L/C filters need to match the frequency of the ceramic filter. If they don’t, alignment is needed.



**Fig. 8: User-selectable IF bandwidths let the listener narrow the response for weak stations, or widen the bandwidth for highest fidelity on strong RF signals.**

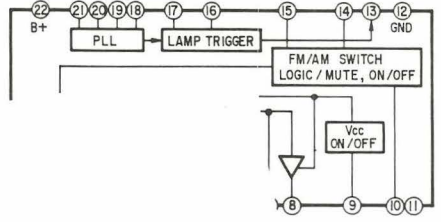


**Fig.9: Multiple IF stages normally use a combination of fixed-tuned ceramic filters and adjustable L/C stages to select the different bandwidth combinations. The L/C stages must be tuned to the same center frequency as the ceramic filters for best performance.**

The SG80's tuneable sweep system lets you do both. The center marker can be set to match the fixed frequency established by the ceramic filters. The sweep curve is used to observe the effect of adjusting the coils in the tank circuits during alignment.

### Digital Decoder Processing

For many years, stereo decoders used analog circuits. A tuned stage detected the 19 kHz pilot. If the pilot had enough amplitude, its frequency was doubled to produce the 38 kHz signal representing the stereo subcarrier. The 38 kHz then fed to a diode or transistor bridge to recover the L-R stereo difference signal needed to recover the left and right channels.



**Fig.10: Modern stereo decoders are PLL based. The PLL runs at 4 times the 19 kHz pilot (76 kHz) to prevent noise from the pilot or the subcarrier from affecting stereo separation.**

Each stage degraded stereo separation. "Crosstalk" resulted as some left-channel audio leaked into the right channel, and vice versa. Additional crosstalk resulted from noise mixing with the 19 kHz pilot.

Frequently, tuning the 19 and 38 kHz transformers for the highest level of 38 kHz signal introduced phase shift reducing separation. Best separation required the stage to be detuned, which made noise even more of a problem.

Digitally controlled phase-locked-loop (PLL) decoders (not to be confused with PLL FM detectors or front ends) nearly eliminate these problems in modern FM receivers. The PLL uses an independent oscillator running at 76 kHz (4 times the 19 kHz pilot). The incoming pilot only keeps the oscillator locked to the station signal. Since the pilot itself is not fed to the decoder, any noise it carries is blocked. Since the oscillator's phase is independent of L/C tank tuning, it can produce maximum output without introducing phase errors.

The adjustment of most decoders becomes a "go/no-go" setup. Sometimes, a frequency counter is used to adjust the oscillator's free-running frequency to exactly 38 kHz. In other cases, you feed the SG80's stereo signal into

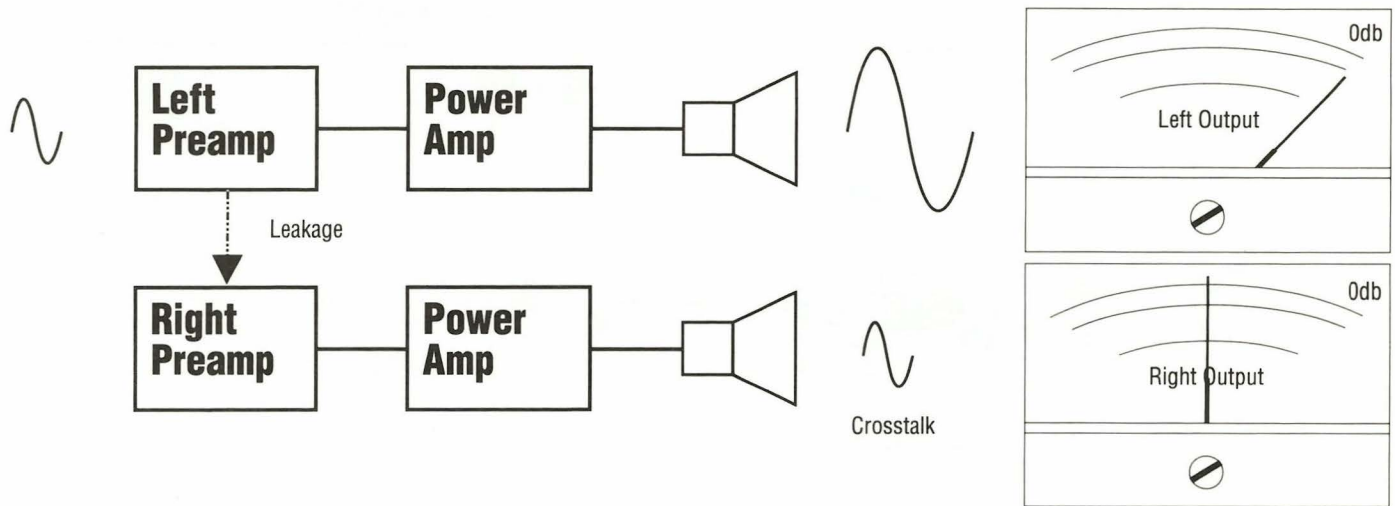
the antenna terminals, and then note the two points on the PLL adjustment that cause stereo to drop out. Then, center the control between these two mechanical limits to produce the best stability.

More importantly, a generator which produces stereo signals with separation better than the decoder is needed for testing. Since some receivers are capable of separation of better than 70 decibels, the generator needs even higher performance levels.

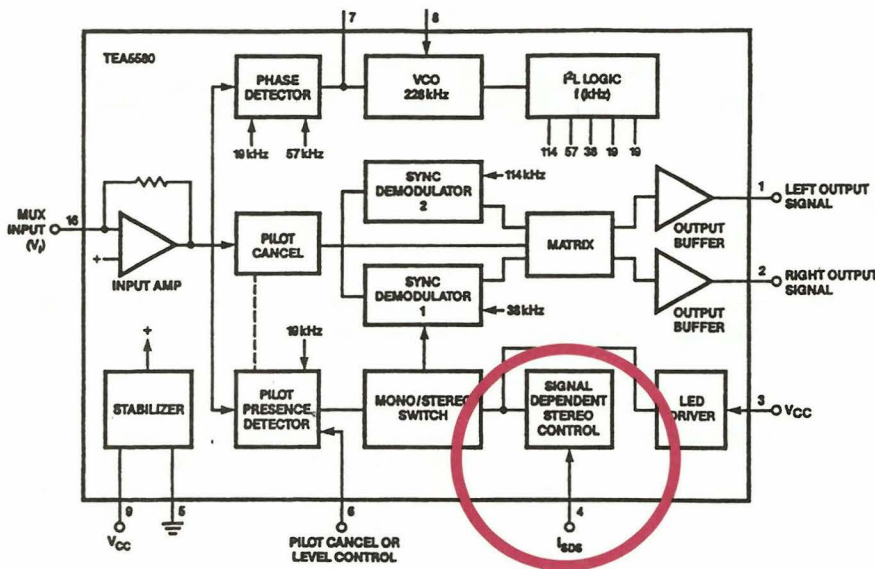
### Stereo Blend

FM stereo performance degrades at weak RF signal levels. The main problem is that the high modulating frequencies (which represent the L-R stereo difference channel) are more severely affected by noise than the lower frequency L+R signal. This is a limitation of any FM system, and modern high gain receiver design does not eliminate the problem.

The effect is increased noise (hiss) on weak signals. It is especially noticeable in automotive radios, since the station's signal RF level varies constantly.



**Fig. 11: The stereo separation test measures how much of the left signal leaks into the right channel to confirm the decoder works correctly.**



**Fig. 12: Modern receivers use a “blend” circuit to reduce the separation at low RF levels to reduce the effects of noise on the output. A bad RF or IF stage may cause reduced separation, even on strong local stations.**

Some receivers have a “mono” switch to let the listener force the receiver into the monophonic mode when the stereo information contributes too much noise. Another solution is adding circuits to automatically switch to mono at low signal levels. However, this causes a sudden change in the sound quality, which can cause a “fluttering” effect when driving in some areas as the receiver rapidly switches in and out of stereo.

Better quality receivers use a “blend” or “signal dependent stereo control” circuit to avoid these “all or nothing” choices. These circuits are built into the stereo decoder IC. An external detector senses the level of the incoming signal and produces a DC bias which adjusts separation. The decoder provides maximum separation (full stereo) on a strong signal. Weaker signals produce less separation, but still have some

stereo effect.

When the signal drops too far, the blend circuits reduce separation to nearly zero (mono). Proper time constants cause the increase or reduction in separation to occur at a rate that is normally not objectionable.

A defective blend circuit may cause reduced separation. Or, a defective RF or IF amplifier may cause the blend circuits to operate with reduced separation, even on strong local stations.

The SG80 lets you dynamically test the blend circuits. First, test for stereo separation at a high signal level (65 dBf) to ensure the stereo decoder works correctly when picking up strong signals. Then reduce the signal level and

check the stereo performance again. If the blend circuits are working correctly, the receiver should show less separation at the reduced RF level.

When troubleshooting blend problems, measure or substitute the DC voltage at the IC pin which controls the blend circuit. If the voltage does not change with signal level, suspect a problem in the signal level detector, which samples either the RF or the IF signals. If you are using signal substitution, from an external DC power supply, you should see a change in separation as you vary the control voltage through its normal range of values.

Poor RF gain can also cause reduced separation at the 65 dBf reference level. Perform the 50 dB quieting test to confirm the sensitivity is normal. If not, troubleshoot the RF or IF stages.

**For more information  
Call Toll Free 1-800-SENCORE  
(1-800-736-2673)**

**SENCORE**  
3200 Sencore Drive Sioux Falls, South Dakota 57107

# Notes