

Programming Sync Timing Parameters Into The CM2000

Importance of Proper Timing

The horizontal and vertical sync signals fed to a monitor are responsible for synchronizing the horizontal and vertical oscillators to the incoming video signals. The oscillators in turn feed the driver and output stages which move the electron beam up and down and back and forth across the face of the CRT.

The timing of the sync signals in relationship to the video establishes the position of the picture that is displayed on the CRT. If the sync and video timings are incorrect the displayed picture will be the wrong size, will be shifted up or down, or will be shifted to the left or right.

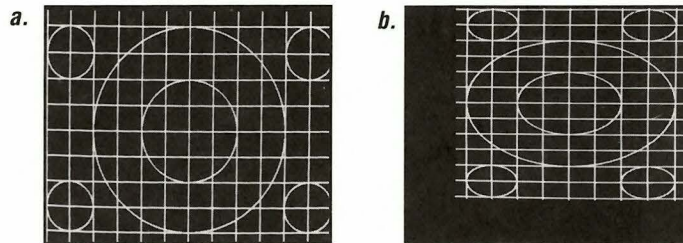

Fig. 1: (a) The display is properly sized and centered. (b) Display is schrunched and shifted because of incorrect timing between the sync signals and video.

Four Sync Parameters

The horizontal and vertical sync signals each have four parameters: front porch time, sync time, back porch time, and active video time. The combination of front porch, back porch, and sync times make up blanking time. Blanking time plus active video time equals the total scan time.

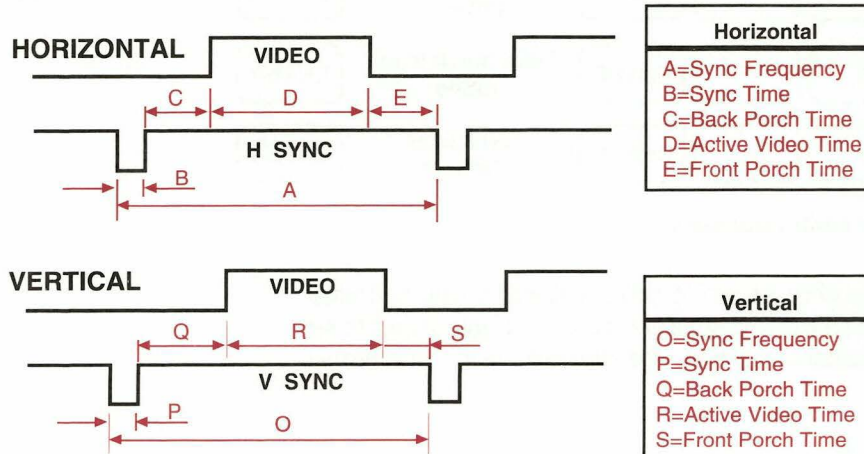

Fig. 2: Four timing parameters: front porch, sync, back porch, and active video, establish the size and centering of the raster on the CRT.

#185 981#

When To Program Sync Parameters

Memory locations 0-19 in the CM2000 contain the setups for the most common computer monitor formats. These setups contain the correct horizontal and vertical sync frequencies and pixel counts, as well as the timing parameters for vertical and horizontal front porch, sync, and back porch.

If you enter the scanning frequencies and pixel rates for a computer monitor format the CM2000 does not recognize, the scan and sync parameters will automatically default to 80% displayed video and 20% blanking. The blanking pulse time will be divided evenly between the front porch, sync, and back porch. If the computer monitor does not use a 80% video 20% blanking timing format (with blanking divided into thirds), a locked in pattern will appear on the display, but it will not be centered.

You can center the pattern on the display by changing the timing of the vertical and horizontal front porch, back porch, and sync to the values the computer monitor has been designed to receive. You can change the timing of these parameters from the front panel of the CM2000.

Programming The Sync Time Parameters

In order to change any of the timing parameters, you must enter a series of keystrokes that puts the CM2000 into the "programming" mode. This is completed by pressing STORE, 8, 0, and then ENTER.

Press:

STORE	8	0	ENTER
-------	---	---	-------

Fig. 3: Keystrokes to place the CM2000 into the program mode.

Once the CM2000 is in the program mode, you can start entering the timing values for the horizontal and vertical front porch, sync, and back porch parameters. The values you enter will appear in the right hand display located above the DIGITAL DISPLAY switch. The following key sequences are used to program vertical and horizontal sync time.

Programming Vertical Blanking Parameters

Front Porch Time	Press	<table border="1"><tr><td>STORE</td><td>8</td><td>1</td><td>ENTER</td></tr></table>	STORE	8	1	ENTER	"front porch time" (mSec)	<table border="1"><tr><td>ENTER</td></tr></table>	ENTER
STORE	8	1	ENTER						
ENTER									
Back Porch Time	Press	<table border="1"><tr><td>STORE</td><td>8</td><td>2</td><td>ENTER</td></tr></table>	STORE	8	2	ENTER	"back porch time" (mSec)	<table border="1"><tr><td>ENTER</td></tr></table>	ENTER
STORE	8	2	ENTER						
ENTER									
Sync Time	Press	<table border="1"><tr><td>STORE</td><td>8</td><td>3</td><td>ENTER</td></tr></table>	STORE	8	3	ENTER	"sync time" (mSec)	<table border="1"><tr><td>ENTER</td></tr></table>	ENTER
STORE	8	3	ENTER						
ENTER									

Fig. 4: Keystrokes for programming vertical timing parameters.

In the program mode, the vertical sync frequency is automatically calculated from the horizontal sync frequency, vertical pixel number, and sync time parameters you enter. If you attempt to set the vertical sync frequency while in the programming mode, the error code "E 4" will appear in the right hand display.

Programming Horizontal Blanking Parameters

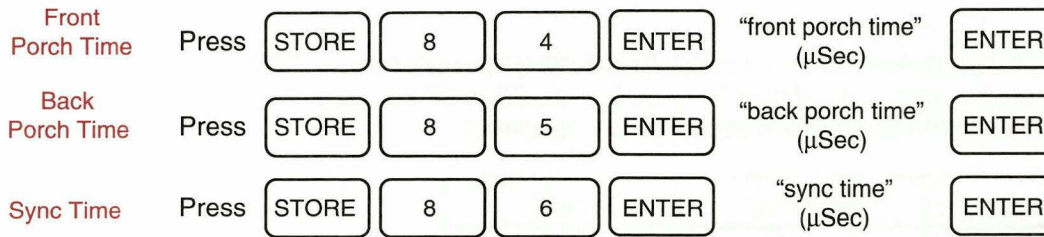

Fig. 5: Keystrokes for programming horizontal timing parameters.

You must enter all three parameters (front porch, sync, and back porch) as a group for either vertical or horizontal sync timing before those parameters take effect. Once you have entered values for all three, you can go back and modify any of the three parameters individually.

If an "E 9" appears in the right hand display when you attempt to store a timing parameter, the "sync time" programming mode has not been enabled. Press: STORE, 8, 0, and then ENTER and begin again.

Storing The New Format

Once you have entered the timing parameters for the new setup, you can store them for future use. Storage locations 20-39 are available for user setups. All six timing parameters will be stored in the same memory location. The CM2000's memory is nonvolatile so the setup will not be lost when the unit is shut off or unplugged. To store the setup in the CM2000, enter the keystrokes shown below:

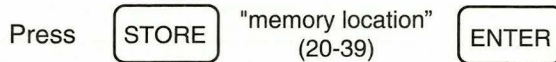

Fig. 6: Keystrokes for storing a programmed setup.

Checking A Timing Parameter

You may want to check the time you've entered for one of the parameters. This can be done by recalling the location where the parameter is stored. The value will appear in the right hand display. You cannot recall the timing values of the setups stored in memory locations 0-19. If you attempt to do this, three 8's will appear in the right hand display.

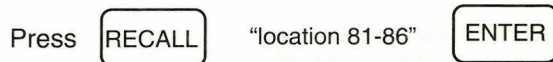

Fig. 7a: Keystrokes for recalling a stored timing parameter.

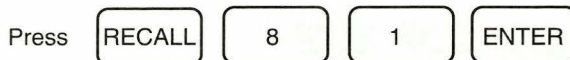

Fig. 7b: Keystrokes to check the front porch time of the vertical blanking pulse.

Programming Example

The following chart contains the timing parameters for a computer monitor. Follow steps 1-9 to program this information into the CM2000. In this example, the setup is stored in memory location 20. When RECALL, 2, 0, and ENTER are pressed, the CM2000 will generate signals with the timing values you've programmed.

Parameter	Horizontal	Vertical
Frequency	65.2 kHz	61.7 Hz
Resolution	1024 Pixels	1024 Pixels
Front Porch	.360 μ Sec	.300 mSec
Sync	.770 μ Sec	.114 mSec
Back Porch	.770 μ Sec	.114 mSec
Polarity	+	-

1. Set **H FREQ** to 65.2 kHz **H PIXEL** to 1024 **V FREQ** to 61.7 Hz **V PIXEL** to 1024
2. Press **STORE** **8** **0** **ENTER** ("scan time" program mode)
3. Press **STORE** **8** **1** **ENTER** **.** **3** **ENTER** (vertical front porch)
4. Press **STORE** **8** **2** **ENTER** **.** **1** **1** **4** **ENTER** (vertical back porch)
5. Press **STORE** **8** **3** **ENTER** **.** **1** **1** **4** **ENTER** (vertical sync)
6. Press **STORE** **8** **4** **ENTER** **.** **3** **6** **0** **ENTER** (horizontal front porch)
7. Press **STORE** **8** **5** **ENTER** **.** **7** **7** **0** **ENTER** (horizontal back porch)
8. Press **STORE** **8** **6** **ENTER** **.** **7** **7** **0** **ENTER** (horizontal sync)
9. Press **STORE** **2** **0** **ENTER** (Store In Memory Location 20)

**For more information,
Call Toll Free 1-800-SENCORE
(1-800-736-2673)**

SENCORE
3200 Sencore Drive, Sioux Falls, SD 57107