

Troubleshooting "Bad Head" Symptoms With The VC93 All Format VCR Analyzer

Defects in many circuits, including the FM luminance circuits, servos, or even bad tape path alignment can cause symptoms that look like bad video heads. The VC93 helps you quickly troubleshoot "bad head" symptoms by confirming whether the circuits between the rotary transformer and the head switcher are working properly.

dures, the cause of the problem is in another section of the VCR. For more details on isolating troubles in the servo circuits, refer to Sencore Tech Tip #186 "Testing VCR Servos With The VC93 All Format VCR Analyzer."

Analyzer"). In older VCRs, the entire monitor screen is snow (Figure 3A). Newer machines often mute the video and produce a blank or solid-color raster (Figure 3B). If the video is muted you need to unmute the video to uncover the VCR's true symptom.

Symptom of a Bad Head or Head Circuit

Before performing the procedures in this Tech Tip, you should confirm that the symptom is one that is likely caused by a problem in the head circuits to prevent unnecessary troubleshooting steps. A defect in the head circuit will cause either of the following two problems. If the symptom is not one of these, the problem is a defect in the servos, or in the tape path alignment.

The first symptom caused by a defect in the head circuits is complete loss of video. This symptom could be caused by both video channels failing simultaneously, or could be the result of a problem in the stages which follow the head circuits. (Refer to Tech Tip #193 "Troubleshooting VCR Luminance Circuits With The VC93 All Format VCR



Fig. 1: Many VCR circuits can produce "bad head" symptoms.

This Tech Tip explains how to confirm proper operation of the head circuits which includes the video heads, rotary transformer, pre-amps, and headswitcher (Figure 2). If the problem exists after completing these proce-

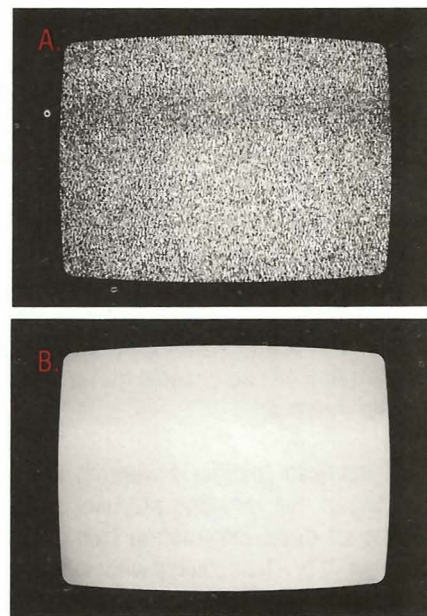

Fig. 3: A failure in both head channels may produce these symptoms.

The second symptom of a bad head channel occurs when only one of the two video heads fails. In this case the VCR produces a noisy playback picture as in Figure 4. The important part of interpreting this symptom is that the noise MUST cover the picture entirely from top to bottom. If any portion of the picture is clear, even a few inches, you do not have a defective head. The problem is likely servo or tape path related.

Note: Do not use a playback monitor that uses vertical countdown circuits. These sets blank the noise from one field of video and will show several inches of clear picture at the bottom of the screen if the video head is bad.

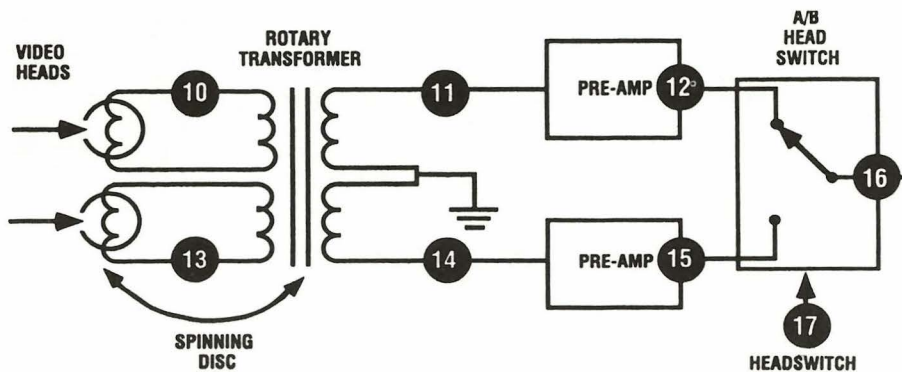

Fig. 2: VCR head circuits.



Fig. 4: A failure in just one head channel produces a picture that has noise throughout the entire screen.

Let's understand how this symptom can occur. The video heads work in pairs (Figure 5). A 2-head VCR uses a single pair of video heads for all tape speeds. As the tape plays, each head channel picks up one field. (A field is one set of scan lines from the top of the picture to the bottom, or one-half of the total scan lines. The whole picture requires two fields.) A head switcher alternately switches between the head channels to select the output from the head channel that is in contact with the tape.

When one head channel is working and the other is bad, the resulting playback picture consists of good information from top to bottom from one field, mixed with noise from top to bottom from the other field. If any part of the picture from top to bottom is clear, the problem is not in either of the head channels.

VCRs that have four video heads still use only two heads to produce the picture. However, different head pairs are selected depending on the playback speed (Figure 6). One pair is used for the fastest playback speed (SP), while the other pair is used for the remaining speeds. A "head selector" chooses which head pair is used. Problems in the head selector may produce a bad head symptom. If the deck has an odd number of heads (three or five), the extra head is used to provide a clear picture during special features such as stop-action or scanning. This "special effects" or "trick" head is not used when playing a tape at normal speed.

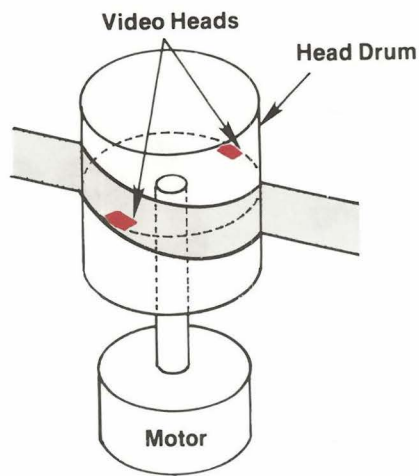

Fig. 5: The video heads work in pairs with each head picking up one video field.

Using The VC93 To Troubleshoot Head Circuit Problems

To determine if the head circuits are working properly you will inject the Playback Head Sub signal from the VC93 into the head circuits and monitor the playback signal at the VCR's RF or video output. If the signal passes through from your injection point to the playback monitor, you know the circuitry in between is working. Playback a prerecorded tape while injecting the Playback Head Sub signal. If you are injecting after the bad stage, you should see a locked video pattern from the VC93 across the entire CRT screen. Use a prerecorded tape with movement (such as an off-air program or a movie), or a test tape that has the crosshatch pattern recorded on it. These tapes will provide the best contrast to see the VC93 test signal.

Substitution works a little differently in the head circuits than in other circuits because

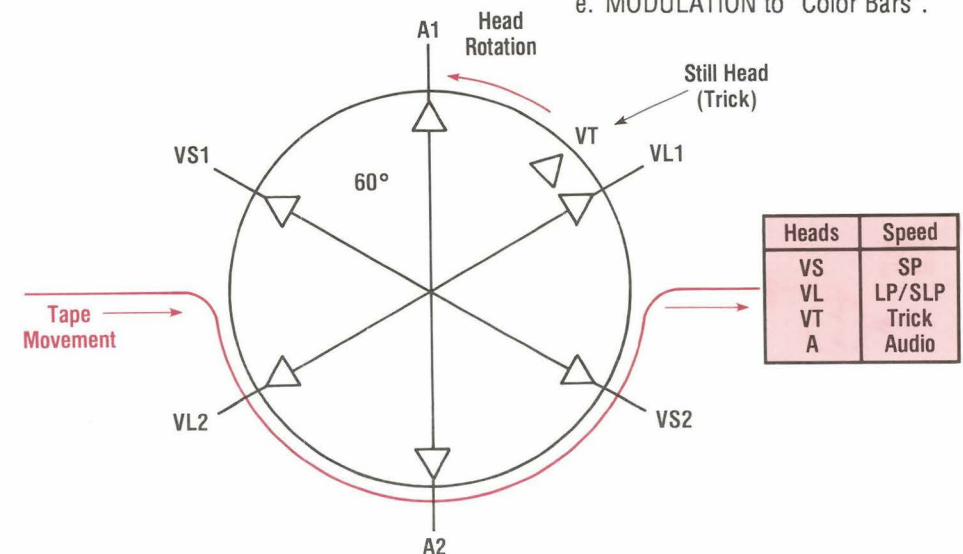

Fig. 6: 4-head VCRs select a different head pair based on tape speed.

there are two parallel signal paths. The head switcher alternately selects between the channels, so as you inject into one channel, the other continues to work and supplies its signal to the output. (This signal may be tape signal or noise, depending on whether the channel is working or not.)

You most likely will not see color in the picture when you are injecting a signal into the head circuits. If you do see color, it likely will not be locked and will come and go. This is because the VC93's signal is not phase-locked to the VCR. If you want to see locked color, you will need to use the CHROMA LOCK INPUT of the VC93, as explained in the manual.

Because the heads spin, you can't make a direct connection to them. Instead, inject at the output of the rotary transformer, or at the head amplifier connector located on the main PC board. (Don't attempt to inductively couple the VC93 signal into the head channel with a "loop." Doing so provides very unreliable results since you do not know what circuits are picking up the signal.)

To substitute into the head circuits:

1. Connect a TV monitor to the VCR's RF or video output.
2. Set the VC93 as follows:
 - a. VCR FORMAT switch to match the VCR format of the VCR being serviced.
 - b. PLAYBACK SIGNAL to "Lum".
 - c. PLAYBACK RANGE to "Playback Head Sub".
 - d. PLAYBACK LEVEL to "0".
 - e. MODULATION to "Color Bars".

3. Connect the HEAD SUBSTITUTION TEST LEAD to the VC93 PLAYBACK OUTPUT jack.
4. Locate the connector on the main PC board coming from the heads. Connect the HEAD SUBSTITUTION TEST LEAD as follows:
 - a. Red leads to the preamplifier inputs. (Ch. A and Ch. B)
 - b. Black lead to circuit ground.
5. Playback a prerecorded tape and observe the monitor.
6. Adjust the PLAYBACK LEVEL control for best picture.

Note: Do not select the .5VPP and 5VPP range. This could produce enough signal to feed back through the video heads and record over the tape.

If the luminance portion of the VC93 Color Bars video pattern does not appear, the problem is after the injection point. Check the head amplifier IC, the record/playback switching, the wiring, and the head switching pulse. If they are good the problem is after the head circuits. For more information on troubleshooting the stages after the head circuits, refer to Tech Tip #193.

If the Color Bars video pattern appears, the signal path after the injection point is good. You know this because the VC93 is replacing (swamping out) the tape signal from the heads and replacing it with a known good signal. You now need to isolate the trouble to the heads or the rotary transformer. Begin by confirming video head operation as explained in the following section.

Determining When To Replace the Video Heads

If injecting into both preamps produces a good Color Bars video pattern at the output, you know that the preamps and circuits that follow are good. Now you need to determine if the heads or rotary transformer are really defective. You do this by injecting into one channel at a time and seeing if the other channel picks up the tape signal.

To isolate head problems:

1. Connect the VC93 to the VCR as explained steps 1-5 of the previous section.
2. Remove one of the VC93 test leads from the preamplifier and monitor the picture on the TV.
3. Readjust the PLAYBACK LEVEL control if necessary to view the tape signal and the VC93 signal on the TV. (Keep the PLAYBACK RANGE control set to "Playback Head Sub".

Your injection will produce one of the following results:

A mixture of the VC93 signal and the tape signal, as shown in Figure 7, means that the video head in the channel opposite the injection point is picking up the tape signal. Both the video head and the rotary channel are good. Check the remaining video head and rotary transformer by repeating your injection into the other channel. If you obtain a mixture of VC93 video pattern and tape signal when substituting for both channels, the problem that is causing the bad head symptom is either in the servos or the tape path alignment.

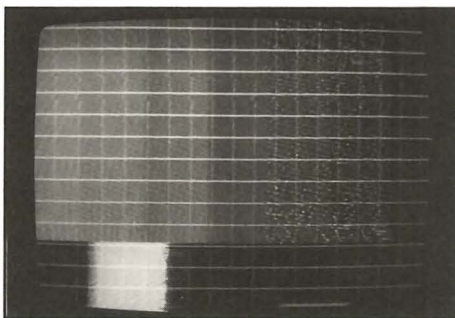

Fig. 7: Injecting the VC93 signal into one pre-amp produces a mixture of VC93 signal (color bars) and tape signal (crosshatch). This indicates that the head in the channel opposite the VC93 injection is good.

If injecting the VC93 signal produces a mixture of VC93 signal and noise as shown in Figure 8, you know that either the video head or the rotary transformer in the channel opposite the injection point is bad. To determine which is at fault, refer to the next section, "Testing Rotary Transformers." If the rotary transformer passes the test, replace the video heads.

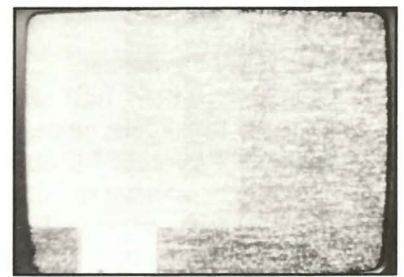

Fig. 8: A picture that is 1 field snow/1 field VC93 signal as shown here, indicates that the signal from the tape is not getting to the pre-amp. The snow is the result of the missing tape signal.

Testing Rotary Transformers

The signal from each spinning head is coupled to the stationary circuits by a winding on the rotary transformer. Rotary transformers don't fail as often as video heads, but they can develop a shorted turn, an open winding, or a cold solder connection. A defective rotary transformer winding will produce a symptom of a bad video head.

A rotary transformer couples signals equally well whether it is rotating or not. Check the rotary transformer windings by injecting a signal into the input (rotating section) and measuring the peak-to-peak voltage on the output (stationary section).

To test a rotary transformer:

1. Turn the VCR off.
2. Set the VC93 as follows:
 - a. VCR FORMAT to format being serviced.
 - b. MODULATION to "Color Bars".
 - c. PLAYBACK RANGE to "5VPP".
 - d. PLAYBACK SIGNAL to "Lum".
3. Connect the DIRECT TEST LEAD to the VC93 PLAYBACK OUTPUT jack.
4. Set the playback output level:
 - a. Set the OUTPUT SIGNAL MONITOR/DVM to "PPV".
 - b. Connect the DVM TEST LEADS to the PPV & DCV INPUT.
 - c. Connect the DVM TEST LEADS to the DIRECT TEST LEADS.
 - d. Adjust the PLAYBACK LEVEL control for an output of 2VPP.

5. Test the rotary transformer:
 - a. Connect the DIRECT TEST LEAD to the rotary transformer primary.
 - b. Connect the DVM TEST LEADS to the rotary transformer secondary.
 - c. Read the results on the OUTPUT SIGNAL LEVEL / DVM LCD readout.
 - d. Repeat steps 5a. through 5c. for the remaining windings.

If the readings are similar for each winding, the rotary transformer is good. If any winding reads lower than the rest, or gives no reading at all, replace the rotary transformer.

**For More Information,
Call Toll Free 1-800-SENCORE
(1-800-736-2673)**

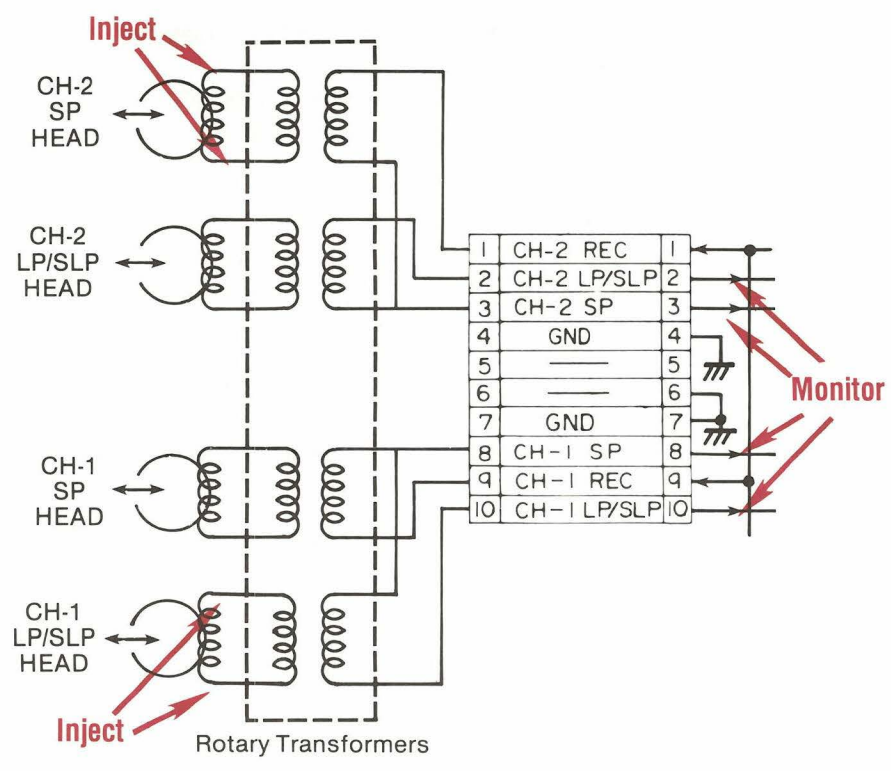

Fig. 9: Inject the VC93 Playback "Lum" Signal at the primary and monitor the output at the connector on the main PC board. Confirm that each section has the same peak-to-peak level.

SENCORE
3200 Sencore Drive, Sioux Falls, South Dakota 57107