

Understanding The HA2500's Horiz Driver Test

Horizontal output stage symptoms and component failures are often caused by problems in the horizontal driver stage. The horizontal driver stage is seldom suspected, and often when it has a defect, the scope waveform at the base of the horizontal output transistor looks normal. Precious service time is often lost and horizontal output stage components are needlessly replaced or destroyed.

This Tech Tip explains how the horizontal driver stage works and how the drive current output to the base of a bipolar horizontal output transistor can be controlled in a wide range multi-frequency video display. It also covers typical driver stage symptoms and explains how to analyze the horizontal driver stage with the HA2500's Horiz. Driver Test.

drive a bipolar horizontal output transistor, is commonly a discrete transistor amplifier stage. The amplifier stage consists of five main elements as shown in Fig. 1. The basic driver stage includes: 1) transistor, 2) transformer, 3) primary resistor 4) RC network and, 5) primary filter capacitor.

The driver transistor is a medium power transistor that operates with voltages from 10 to 100 volts. The transistor may be a conventional bipolar or newer MOSFET type. The driver transistor operates as an on or off switch. When driven on by the base or gate drive signal, the transistor permits current flow in the driver transformer primary. When driven off by the base or gate drive signal, the current path is opened. The driver transformer couples the

output of the driver stage to the horizontal output transistor. The driver transformer provides impedance matching and current step up to drive the H.O.T. A typical driver transformer turns ratio is 30:1 from the primary to secondary. This ratio matches the high impedance of the driver amplifier to the low base/emitter junction impedance of the horizontal output transistor. It further steps up the driver transformer primary current to produce a much higher secondary H.O.T. base current.

A primary resistor is part of the current path with the driver transistor and transformer primary. The resistor establishes the level of driver transformer primary current along with the power supply voltage to the driver stage. An increase or decrease

Understanding Horizontal Driver Stages

The horizontal driver stage outputs a drive signal to turn the horizontal output transistor (H.O.T) on and off. The drive signal consists of a positive output bias voltage to forward bias the base/emitter junction and a negative output bias voltage to reverse bias the base/emitter junction. The positive output voltage produces base current turning on the H.O.T. The negative output voltage quickly rids the base of current turning off the H.O.T.

The horizontal driver stage, used to

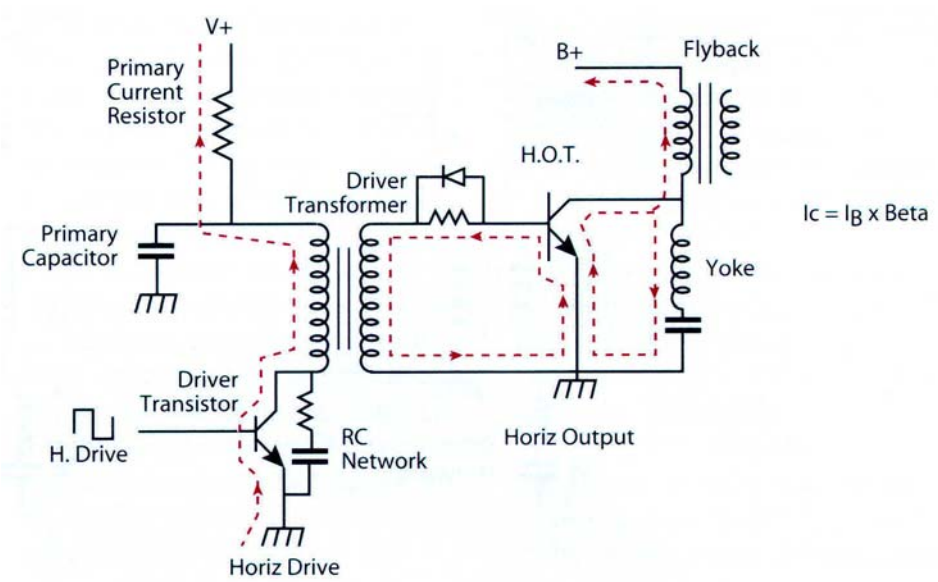

Fig. 1: Basic components of a horizontal driver stage and resulting base currents in a bipolar horizontal output stage.

#223 223#

in the resistor value directly affects the primary current and the driver stage's output. Often two resistors in parallel are used.

A bypass filter capacitor connects from the voltage input side of the driver transformer primary to ground. The filter capacitor effectively increases the transformer primary current by charging and discharging current through the transformer primary.

An RC network parallels the driver transistor from the collector or drain to ground. The network protects the transistor from induced voltages. The network has little impact on the horizontal driver stage's output current. In some driver stages, the RC network is placed across the driver transformer primary winding.

An input horizontal signal to the base or gate of the horizontal drive stage is needed for normal operations. The drive signal is typically a square wave at the horizontal frequency. During a portion of the input drive waveform, the driver transistor is biased on and

current flows through the transistor, driver transformer primary, and primary resistor. The discharge action of the bypass filter capacitor produces additional current in the driver transformer primary. Current builds in the transformer primary producing an expanding magnetic field and induced voltage to the secondary. The induced voltage produces secondary current that depletes the horizontal output transistor base of conduction carriers switching the horizontal output transistor off.

When the driver transistor is biased off by the remaining portion of the horizontal drive input, current ceases in the driver transistor. The magnetic field in the primary of the driver transformer collapses inducing voltage into the driver transformer secondary to forward bias the base/emitter junction of the horizontal output transistor. The driver stage and transformer action produce an increasing secondary base current in the horizontal output transistor. The base current increases to a level that biases on the horizontal output transistor and continues to increase to

permit the buildup of collector current for the horizontal output stage.

Changing Driver Stage Output Current In A Multi-Frequency Monitor

Multi-frequency CRT displays operate through a range of many different horizontal frequencies. The horizontal driver stage must produce the proper H.O.T. base current through the entire horizontal frequency range. Monitors with a wide horizontal operating range may change the horizontal driver stage to increase or decrease the base drive current for the H.O.T. At lower operating resolutions or frequencies, the base current may be increased compared to higher operating frequencies.

The reason for this is that the H.O.T. has slightly different collector current requirements depending on the horizontal frequency. At lower operating frequencies, the horizontal output transistor conducts longer reaching higher collector current peaks to produce the required high voltage and/or deflection. Therefore, a

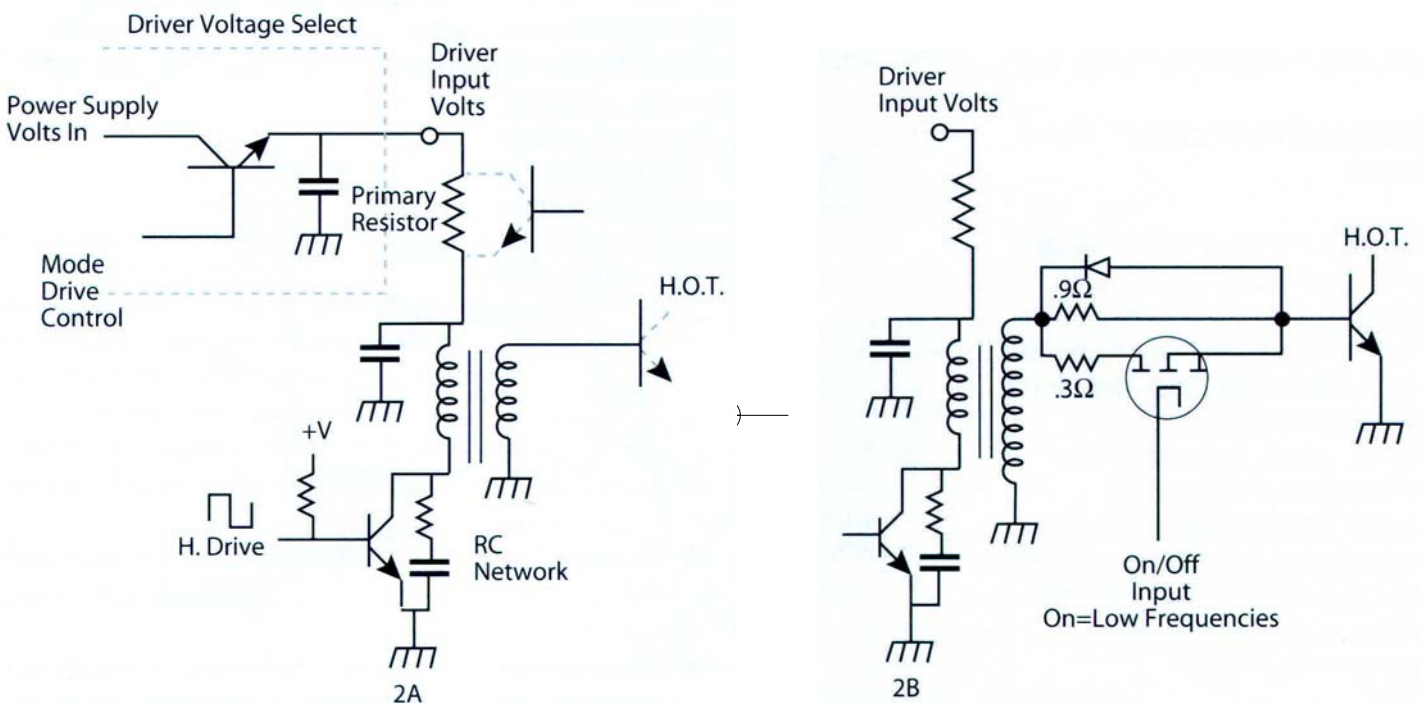

Fig. 2: Two methods in multi-frequency monitors used to control the horizontal driver stage's output drive current.

higher level of base drive current is required to reach the needed collector current. A driver stage designed to supply sufficient base drive current for the highest operating frequency overdrives the H.O.T. producing more than the required base current at a much lower operating frequency. This results in a longer turn off time of the H.O.T causing added power dissipation and heating of the H.O.T. To optimize operation of the H.O.T. and reduce transistor heating, the driver stage may be switched between two or more output drive current levels.

Two methods of switching the driver stage output current level to the base of the H.O.T. are shown in Fig. 2A. The first method involves changing the level of primary current in the driver transformer. This can be done by changing the power supply voltage applied to the horizontal driver stage or by varying the value of the primary resistor. Increasing the power supply voltage increases the driver transformer's primary current and the output base drive current. Decreasing the power supply voltage to the driver stage decreases the output base drive current.

The voltage to the horizontal driver stage can be selected or varied using power supply regulating methods. A pass transistor (as shown in Fig. 2A) outputs voltage at its emitter according to the voltage established at its base. Switching converters similar to those used by high voltage/deflection regulators may also be used.

Varying the primary resistor value also changes the transformer primary current. The resistance value can be changed by placing a transistor in parallel with the primary resistor. By controlling the transistor's conductance, the resistor value can be changed to increase or decrease

the driver transformer's primary current and output current.

A second method of changing the driver stages output drive current is shown in Fig. 2B. Placing a resistor in series with the base current path of the horizontal output transistor reduces the base current to the required level. By switching in a lower value resistor for lower horizontal frequencies, the base drive current is boosted. The resistor can be switched in or out of the base current path with a MOSFET transistor.

Understanding Horizontal Driver Stage Symptoms

The output of the horizontal driver stage is essential for normal operation of the H.O.T. and horizontal output stage. As with any bipolar transistor, it is the base current that becomes critical to normal operation of the H.O.T. It is the horizontal driver stage that produces the proper drive voltage and resulting base current in the bipolar horizontal output transistor.

Consider the normal operation of the H.O.T. When on, the H.O.T.'s collector current rises producing expanding magnetic fields in the flyback transformer and/or yoke (see Fig. 1). The collector current rises to a peak of several amps before the H.O.T. is switched off. The magnetic energy produced by the collector current produces normal high voltage and/or deflection.

The base current produced by the horizontal driver stage determines how much collector current can be produced by a bipolar horizontal output transistor. The H.O.T.'s maximum collector current is determined by multiplying the base current by the transistor's current gain or beta. If the base current is not produced by the driver stage, the H.O.T. cannot be turned on and the

horizontal output stage remains inactive.

If the base current is reduced from normal, the H.O.T. with normal gain cannot produce the required collector current. The symptom depends on the severity of the current decrease. If the base current is reduced only slightly, little if any change in high voltage and/or deflection results. At some level of base current reduction, the collector current peak is limited causing the high voltage and/or deflection to decrease. The flyback pulses at the collector or drain decrease from normal, indicating a decrease in the flyback and/or yoke currents. A severe reduction in base drive current often results in quick heating and failures of the H.O.T.

The reverse bias drive voltage applied to the base of the H.O.T. transistor switches the H.O.T. off to stop collector current. Switching off the H.O.T. as it reaches a current peak of several amps and base current of several hundred milliamps is not simple. The base region of the transistor must be evacuated of charged carriers before collector current ceases. Reduced base drive current slows the transistor turn off leading to increased H.O.T. power dissipation, heating, and premature failure. This failure commonly occurs with reductions in the driver stage's base current long before decreases in the high voltage or deflection occurs.

Intermittents in the horizontal driver stage can be another cause of horizontal output transistor failure. Intermittents cause a fluctuation in the driver stage's output base drive current. These current changes cause abrupt current variations as the horizontal output transistor is driven on and off. Combined with the high currents and voltages produced by the horizontal output stage, the H.O.T. is often damaged.

When To Use The HA2500's Horiz. Driver Test

The HA2500's Horiz Driver Test measures the output drive current capability of the horizontal driver stage. This is the current drive to the base of a bipolar horizontal output transistor. If there is normal high voltage and/or deflection, normal Collector DCV/uS/PPV Dynamic Tests, and the bipolar horizontal output transistor is not overheating, there is little reason to suspect the horizontal driver stage.



Fig. 3: The Horiz. Driver Test is a dynamic test that measures the output drive current capability of the horizontal driver stage.

When horizontal related symptoms exist, the horizontal driver stage should be considered suspect. Use the Horiz. Driver Test when there is good cause to suspect the horizontal driver stage may have insufficient drive output current.

You should suspect the horizontal driver stage and perform the Horiz. Driver Tests when:

1. The original problem was a defective bipolar horizontal output transistor and the HA2500's Load Tests indicate normal.
2. The horizontal output transistor is defective or repeatedly fails but a replacement seems to restore normal operation.
3. The horizontal output stage produces insufficient high voltage and/or deflection (Reduced Collector PPV) but the DCV seems normal.

4. The chassis seems to operate normally (Collector Or Drain DCV/uS/PPV meter tests indicate normal), but the horizontal output transistor gets too hot often failing within hours, days, or weeks of replacement.
5. The horizontal output transistor burns out or gets hot when the chassis horizontal driver stage is used but is fine when using the HA2500's Base Sub Drive.

How The Horiz. Driver Test Works

To accurately measure the driver stage's output current capability, the Horiz. Driver Test simulates the base/emitter junction of a bipolar horizontal output transistor. The test uses a low barrier shottkey diode and small value resistor (see Fig. 4). The polarity of the shottkey diode permits drive current output produced by the driver stage to flow through the resistor during the positive cycle. This closely simulates how the positive drive output cycle of the driver stage produces base current in the horizontal output transistor. The low forward bias voltage of the shottkey diode permits a more sensitive current measurement to better test the driver stage's output current drive capability.

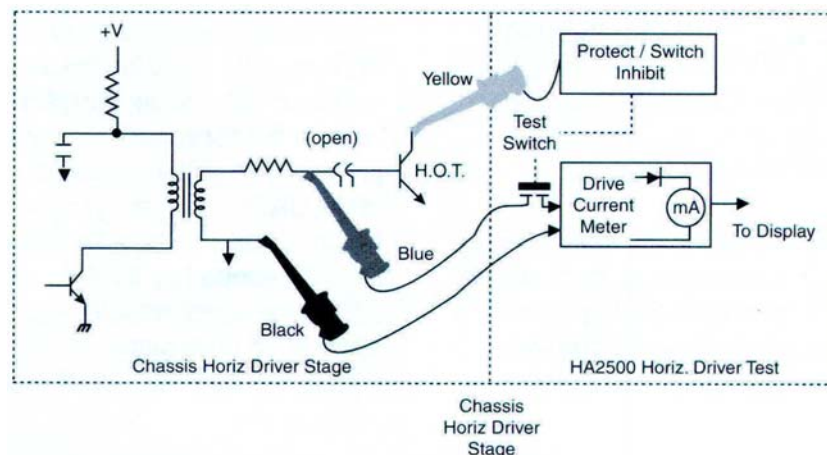

Current through the small value resistor produces a voltage that is relative to the amount of potential output drive current during the positive cycle. A metering circuit measures the voltage and calculates the average positive conduction current. This current is the base drive current that is available from the driver stage to the horizontal output transistor.

How To Perform The Horiz. Driver Test

Performing the Horiz. Driver Test requires that the horizontal output transistor be removed or that the base lead of the horizontal output transistor be opened. This permits all the drive current from the driver stage to be routed to the HA2500's measurement circuit for accurate drive current measurements. It further prevents any chance of damaging the chassis' horizontal output transistor. Before performing the Horiz. Driver Test, remove AC voltage to the chassis and unsolder the H.O.T. or open the circuit path leading from the driver transformer to the base of the horizontal output transistor. There is commonly a jumper, small resistor, inductor, and/or diode between the transformer and H.O.T. base. Unsolder one lead of the component(s) and lift from the

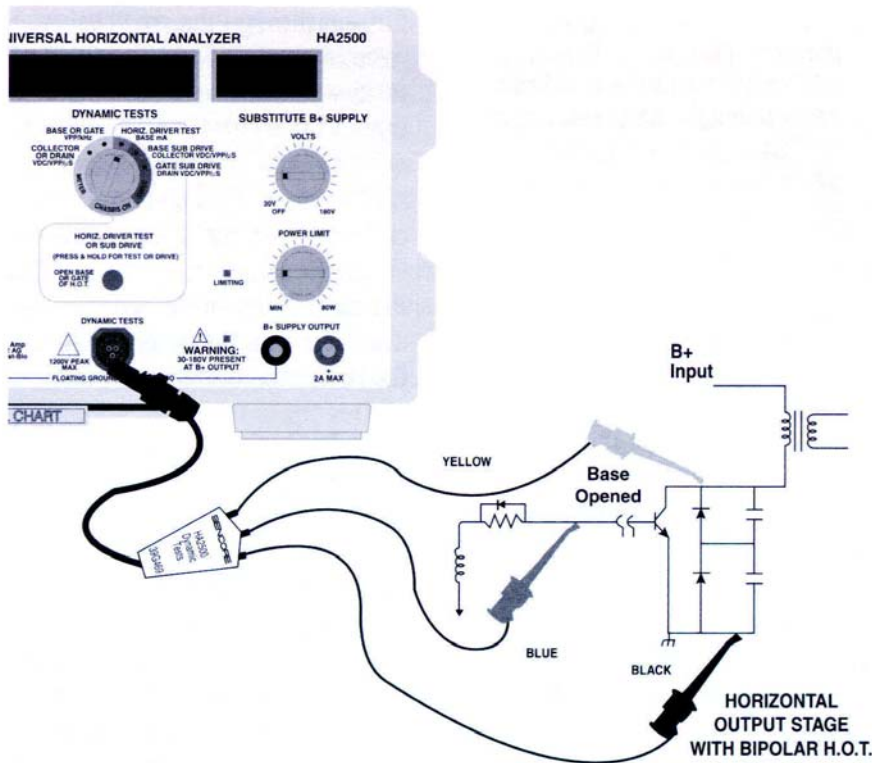

Fig. 5: Dynamic Test Lead connections for performing the Horiz. Driver Test.

circuit board to open the circuit path to the base.

The Horiz. Driver Test is performed using the Dynamic Test Leads. Connect the blue test lead clip to the output of the driver stage at the secondary side of the horizontal driver transformer. This corresponds to the transformer side of the opened path between the transformer and base of the horizontal output transistor (see Fig. 5). Connect the black test lead clip to the horizontal output stage ground typically at the H.O.T.'s emitter or bottom of the driver transformer secondary. Connect the yellow test lead clip to the collector of the horizontal output transistor.

When performing the Horiz. Driver Test, it is important to connect to the circuit point equivalent to the base of the horizontal output transistor. Resistors located between the driver

transformer and the base of the H.O.T. impact the level of base drive current. Always connect the blue clip of the Dynamic Tests Lead to the base side of the resistors if it is unsoldered and lifted from the circuit board.

The Horiz. Driver Test is an active test relying on the chassis horizontal driver stage to produce an output. With no drive output from the driver stage, the test reads little or no mA drive current. To produce an output, the horizontal driver stage must have a horizontal drive input signal from the horizontal oscillator and a power supply voltage and be operational. To confirm the horizontal driver stage is producing an output, apply AC voltage to the chassis and perform the Base or Gate Dynamic Tests. No horizontal drive is indicated by low PPV readings and no frequency readout. Isolate the cause of no drive output before performing the Horiz. Driver Test.

To Perform The Horiz. Driver Test:

1. Remove AC voltage to the chassis.
2. Unsolder the H.O.T. or remove or open the base circuit path.
3. Connect the DYNAMIC TEST leads: Blue clip to driver transformer secondary. Black clip to horizontal stage ground. Yellow clip to collector.
4. Set DYNAMIC TESTS switch to "Horiz. Driver Test."
5. Apply AC voltage to the chassis.
6. Push & Hold the Horiz. Driver Test Or Sub Drive test button.
7. Read the mA current drive.
8. Compare reading to Typical mA Range chart (see the HA2500 Pull Chart or Chart 1 in this Tech Tip).

Interpreting The Horiz. Driver Test mA Readout

The mA readout of the Horiz. Driver Test indicates the level of output base drive current the chassis horizontal driver stage can produce. The amount of output drive current varies between chassis depending on the amount of collector current which must be produced by the horizontal output transistor. The base current peak multiplied by the beta of the horizontal output transistor must satisfy the peak buildup in the H.O.T.'s collector current. The buildup in collector current is determined by the horizontal output stage.

The amount of driver stage output current is determined by the driver stage's power supply voltage, power

HORIZONTAL OUTPUT STAGE TYPE

TYPICAL HORIZ. DRIVER TEST BASE mA RANGES

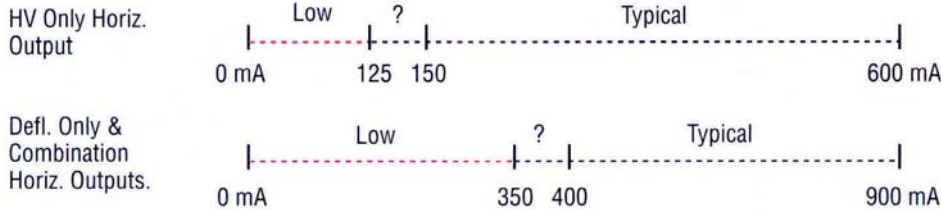

Chart 1: Typical ranges of current expected during the Horiz. Driver Test.

supply current limiting resistor, driver transformer characteristics and resistor between the driver transformer and base of the H.O.T. It is also in part affected by the gain of the driver transistor and its base current. The driver stage components are determined by designers to satisfy the current requirements of the H.O.T. and the horizontal output stage.

Driver stages for bipolar HV only horizontal output stages typically produce base drive currents ranging from 150 to 600 mA. Driver stages of combination HV/Defl. output stages and deflection only output stages typically produce higher drive currents ranging from 350 to 900 mA.

Horiz. Driver Test mA readouts less than the typical mA range shown in the chart indicate a likely weak or insufficient current drive for the horizontal output transistor. Horiz. Driver Test mA readouts greater than the typical range usually do not indicate a problem unless driver stage components have been improperly substituted. Improper substitution can result in higher than normal driver output current and contribute to horizontal output transistor failures.

Note Specific Chassis Horiz. Driver Test Readings

Added benefits of the Horiz. Driver Test can be realized by recording the

normal mA level of a working chassis. On chassis that switch output drive current levels, be sure to select the monitor's highest and lowest operating frequencies or resolutions and record the drive current readings. Then in the future, you can reference the normal mA drive current for that chassis when confronted with horizontal problems. You can also more accurately identify horizontal driver stage problems that are beginning to weaken the drive before they cause major problems.

Isolating Intermittent Horizontal Drive Problems

Intermittent horizontal drive problems can be frustrating as they often cause repeat H.O.T. failures while you are attempting to troubleshoot the symptoms. Also, the waveform observed on an oscilloscope at the base of the H.O.T. may or may not change much and you cannot be sure if a change was caused by the horizontal driver or horizontal output stage.

The HA2500's Horiz. Driver Test readout helps you quickly determine if the current output of the driver stage is intermittent. Simply perform the Horiz. Driver Test and monitor the current readout for a short period of time. Watch the mA readout for any big fluctuations or abrupt changes. A normal current drive output changes the readout by only a few microamps.

An intermittent output drive current causes substantial changes in the mA output.

To isolate intermittent drive problems, try introducing vibrations, heating, stimuli or cooling stimuli to the horizontal driver stage and components while watching the mA readout. After isolating and correcting intermittents, use the Horiz. Driver Test to confirm a constant mA readout. Using the Horiz. Driver Test prevents damage to replacement horizontal output transistors.

For More Information,
Call Toll Free 1-800-SENCORE
(736-2673)

SENCORE

3200 Sencore Drive, Sioux Falls, SD 57107
Fax: 1-605-339-0317 www.sencore.com