

SENCORE®

Means Success In Electronic Servicing

tech tips

Understanding & Using The HA2500's Substitute B+ Supply

The HA2500's Substitute B+ Supply permits testing of the horizontal output stage and high voltage/deflection regulators to full operating voltages independent of the chassis B+ power supply. This lets you identify expensive high voltage component problems without risking damage to the chassis power supply and often before investing in parts and time to repair the power supply.

The Substitute B+ Supply helps troubleshoot breakdown failures of horizontal output components which result in high current loading of the chassis B+ supply at or near full operating voltages. Breakdown failures often quickly damage the horizontal output transistor and power supply components leaving little time to isolate the cause. By subbing and gradually increasing the Bt supply voltage to the horizontal output stage, these problems can be isolated.

Other chassis symptoms can be isolated quickly with the Substitute Bt Supply. Symptoms of reduced Bt voltage to the output stage, X-ray shutdown or momentary high voltage, vertical noises on the CRT picture, intermittents, startup problems and others can be isolated quickly by subbing the B+ supply voltage. This Tech Tip covers the HA2500's Substitute Bt Supply and explains how to use it to substitute for the chassis Bt voltage to the horizontal output stage and HV/deflection regulator.

The HA2500's Substitute B+ Power Supply

The HA2500's Substitute B+ Supply is a variable DC power supply adjustable from 30 to 180 volts. It is designed to substitute for the full range of chassis Bt power supply voltages found in CRT video displays.

The output voltage to the B+ SUPPLY OUTPUT Jacks is switched "OFF" or adjusted through its voltage range with the VOLTS Control. An indicator light, to the left of the Bt SUPPLY OUTPUT Jacks, reminds you of voltage present at the jacks, test lead and chassis circuit if the Bt SUPPLY LEAD is connected to the chassis.

----- WARNING -----

Voltages greater than 30 volts DC are capable of delivering a lethal electrical shock. Do not come in contact with the B+ SUPPLY OUTPUT Jack, B+ SUPPLY TEST LEAD clips, or B+ supply circuit points when using the Substitute B+ Supply.

1. Set the VOLTS control to "OFF" when not using the Substitute B+ Supply.
2. Set the VOLTS control to "OFF" when connecting and disconnecting the B+ SUPPLY LEADS to the chassis or B+ SUPPLY OUTPUT Jacks.
3. Return the VOLTS control to "OFF" after substituting for the chassis B+ voltage. Disconnect the test leads from the chassis and B+ SUPPLY OUTPUT Jacks.
4. Always attach the B+ SUPPLY LEADS securely to circuit test points. Reduce the VOLTS control to "OFF" if a lead(s) becomes detached.

----- WARNING -----

The B+ SUBSTITUTE SUPPLY should be used only by technically qualified persons who understand the potential shock hazard of voltages up to 180 volts applied to the test lead and chassis circuitry.

The power output from the Substitute Bt Supply is determined by the voltage selected with the VOLTS control and the amount of current flowing to the chassis. The Substitute Bt Supply outputs over 80 watts for voltages greater than 40 volts. At voltages between 30 and 40 volts, the Substitute Bt Supply output current is limited to 2 amps, reducing the total power output to 60 watts.

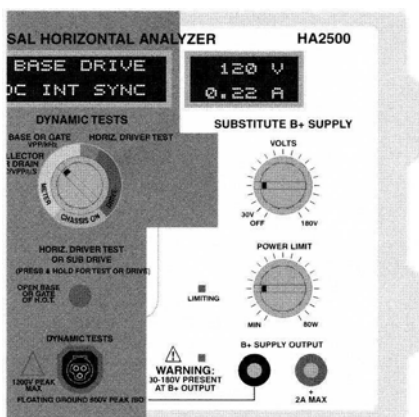

Fig. 1: The variable SUBSTITUTE B+ SUPPLY outputs 30 to 180 volts for substitution of the chassis B+ power supply to test horizontal stages and HV/deflection regulators.

The POWER LIMIT control provides an adjustment to reduce the maximum power output of the Substitute B+ Supply. At the "MIN" setting, the Substitute B+ Supply outputs 3 watts or less. At mid-range, the maximum power output is reduced to 1/2, or 40 watts for voltages ranging from 40-180 volts. Limiting the output power causes the maximum current output of the Substitute B+ Supply to change with the output voltage according to the power formula. For example, at an output of 160 volts, approximately .5 amps can be output (80 watts). At an output of 80 volts, approximately 1 amp can be output. As the POWER LIMIT control is reduced, the maximum output current is reduced accordingly.

A LIMITING light, located to the right of the POWER LIMIT control, illuminates when the output voltage times current of the Substitute B+ Supply is greater than the POWER LIMIT setting. When in limiting, the Substitute B+ Supply cannot further increase its output voltage or current. Increasing the setting of the VOLTS control during limiting does not increase the output voltage or the voltage shown in the digital display.

The fluorescent digital display above the VOLTS control indicates the voltage and current outputs of the Substitute B+ Supply simultaneously. The Substitute B+ Supply display is not affected by the DIGITAL DISPLAY push-button. The voltage measurement is sampled at the B+ Supply Output Jacks for an accurate indication of the output voltage. The current readout indicates the level of output current from the Substitute B+ Supply.

When the VOLTS Control is set to "OFF", the Substitute B+ Supply output is reduced to near 0 volts. If connections are made from the B+ SUPPLY OUTPUT Jack to the chassis, the volts readout reads the voltage present at the chassis test points.

The negative polarity of the B+ SUPPLY OUTPUT JACK is a floating ground common to the DYNAMIC TESTS ground. The ground connections of these outputs should be connected to the same chassis ground point when used together for

testing horizontal output stages.

Understanding Chassis B+ Voltage Substitution

Using the Substitute B+ Supply requires that the chassis B+ power supply path to the horizontal output stage be opened. This prevents the chassis B+ voltage from reaching the horizontal output stage. Once the chassis B+ voltage path is opened, the HA2500's Substitute B+ Supply is connected and used to substitute the B+ voltage to the horizontal output stage. Failure to open the chassis B+ supply path may damage the chassis power supply and/or the HA2500.

The typical B+ voltage path of a multi-frequency display is shown in Fig. 2. The B+ voltage is output from the main switching mode or linear supply. The B+ voltage is stepped up or down to produce normal high voltage and/or deflection by a high voltage/deflecting regulator. This regulator is commonly a switching "buck converter" or "boost converter" type to step up or step down the B+ voltage to a level required by the horizontal output stage. A single frequency display typically does not include a high voltage/deflection regulator so the main B+ supply output feeds the input of horizontal output stage.

With the chassis B+ path opened, connect the B+ SUPPLY LEAD clips from the B+ SUPPLY OUTPUT Jack to the chassis. The AC voltage to the chassis should be turned off and the VOLTS control should be set to "OFF" when connecting and disconnecting test leads. Connect the black banana jack to the black B+ SUPPLY

OUTPUT jack (isolated ground) and the black clip to the horizontal circuit ground of the chassis. Connect the red banana jack to the red B+ SUPPLY OUTPUT Jack (+) and to the horizontal output side of the opened B+ voltage path.

When subbing for the chassis B+ voltage, start at a reduced voltage or power level. This permits reduced voltages and currents in the horizontal output stage. Operating at a reduced voltage or power does not harm or threaten the horizontal output stage. Slowly increase the voltage or power until full operation of the horizontal output stage is reached or defects are observed.

The VOLTS and POWER LIMIT Controls provide the versatility needed to operate the horizontal output stage at reduced levels and increase it to normal operating levels. Start with the VOLTS control to "OFF" and set the POWER LIMIT control to a power setting near the anticipated power demand. If you are unsure of the normal power demand, set the POWER LIMIT to 1/4 scale (approx. 20 watts) for high voltage only horizontal output stages and 1/2 scale (approx. 40 watts) for deflection and combined horizontal output stages. This is a good starting point to limit current in the event of a breakdown problem. You may need to increase the POWER LIMIT control as you near full operating voltages.

Use the HA2500's Dynamic Tests to determine abnormal or normal operation of the horizontal output stage when subbing for the chassis B+ voltage. Connect the DYNAMIC TEST LEAD clips

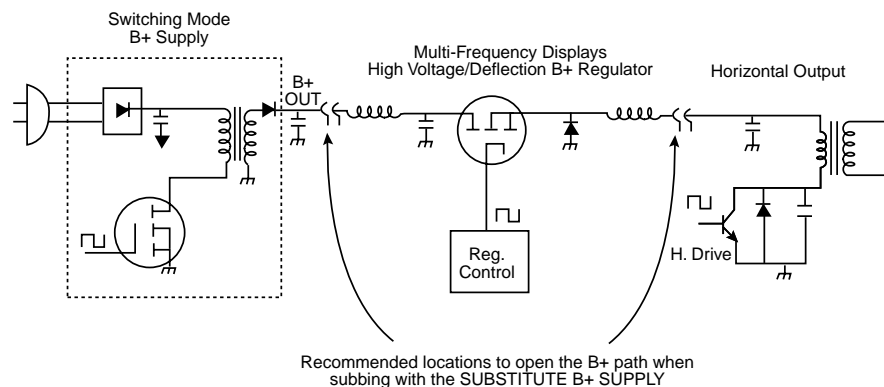

Fig. 2: Typical B+ voltage path in a multi-frequency CRT display and recommended locations to open the B+ path when subbing with the Substitute B+ Supply.

to the proper elements of the horizontal output transistor and select the Collector Or Drain DCV/VPP/ μ S "METER" Dynamic Tests. The black or ground clips of the DYNAMIC TEST LEAD and B+ SUPPLY LEAD should be connected to the same horizontal ground test point.

Monitor the Collector Or Drain Dynamic Tests as you increase the VOLTS Control. You should see the VPP readout increasing. Increase the Substitute B+ Supply voltage until the VPP is near the collector or drain's normal VPP level. Avoid applying too much B+ voltage with the HA2500's Substitute B+ Supply. Too much voltage results in excessive voltages and currents in the chassis horizontal output stage. VPP readings should not exceed 1,200 VPP for a bipolar horizontal output transistor or 900 VPP for a MOSFET output transistor.

If you do not see the VPP readout increasing as you increase the Substitute B+ Supply voltage, check the Collector Or Drain DCV readout. It should be increasing, indicating the HA2500's Substitute B+ Supply voltage is being applied to the horizontal output stage. If the DCV readout is not increasing, check the B+ SUPPLY LEAD or DYNAMIC TESTS LEAD connections and check to confirm you have properly identified the B+ voltage path of the chassis.

If the Collector Or Drain DCV readout increases but the VPP readout does not, check for proper drive to the horizontal output stage using the Base Or Gate VPP/kHz "METER" Dynamic Tests. Horizontal drive may be missing if the chassis power supply is defective, startup circuits are used to start the chassis, or defects exist in the horizontal oscillator or driver stages. If drive is missing, you may use the BASE SUB DRIVE or GATE SUB DRIVE with the Substitute B+ Supply to test the horizontal output stage as explained later in this Tech Tip.

Avoid excessive current output from the Substitute B+ Supply to the horizontal output stage being tested. Excessive current may result from faulty components or component breakdowns causing localized heating or corona. Monitor the current readout of the Substitute B+ Supply as you increase the

VOLTS or POWER LIMIT Controls. Current levels which quickly increase or jump to higher than normal levels indicate a high current load or component breakdown failure.

Follow these guidelines when using the SUBSTITUTE B+ SUPPLY:

1. Always open the chassis B+ voltage path between the chassis power supply output and the horizontal output stage.
2. Always remove AC voltage to the chassis when opening the chassis B+ voltage path and when connecting the B+ SUPPLY LEAD clips to the chassis.
3. Always perform the LOAD TESTS and correct abnormal problems before using the SUBSTITUTE B+ SUPPLY. Remove the LOAD & RINGER test lead clips from the chassis before connecting the B+ SUPPLY LEAD clips.
4. Always start at a reduced voltage and slowly increase the voltage until full horizontal output stage operation is reached or defects are observed.
5. Always avoid applying too much voltage to the horizontal output stage being tested. Connect the DYNAMIC TESTS LEAD and monitor the COLLECTOR OR DRAIN VPP readout. Do not exceed the chassis normal VPP.
6. Always avoid excessive current output from the Substitute B+ Supply to the chassis which may cause localized heating or corona. Monitor the current readout and reduce the VOLTS or POWER LIMIT control if it is excessive.

To Sub the chassis B+ voltage with the SUBSTITUTE B+ SUPPLY:

1. Remove AC voltage to the chassis.
2. Open the chassis B+ voltage path.
Note: Unsolder and open a coil, resistor, or jumper in the B+ supply voltage path to remove B+ to the flyback or high voltage/deflection regulator.
3. With the VOLTS control set to "OFF", connect the B+ SUPPLY LEAD to the

B+ SUPPLY OUTPUT jacks and chassis test points.

4. Set the POWER LIMIT Control. (20W for HV only horizontal output stage, 40W for HV/Defl. combination outputs, 60W for larger CRT size deflection only or combination horizontal output stages)
5. Connect the DYNAMIC TEST lead clips to the H.O.T.
6. Apply AC power to the chassis.
7. Read the Substitute B+ Supply volts readout.
Note: It should read near 0 if the chassis B+ path is opened properly and the B+ SUPPLY LEADS connected properly.
8. Select the BASE OR GATE Dynamic Tests to confirm normal horizontal drive.
Note: If drive is missing, you may need to use the BASE SUB DRIVE or GATE SUB DRIVE with the SUBSTITUTE B+ SUPPLY to test the horizontal output stage.
9. Select the COLLECTOR OR DRAIN Dynamic Tests.
Note: The DCV readout should be near 0 confirming the B+ voltage path to the horizontal output stage is opened.
10. Increase the VOLTS control to sub the chassis B+ voltage. Monitor the voltage and current readouts along with the VPP readout.
Note: If the LIMITING indicator illuminates, the horizontal output stage is demanding excessive current or the POWER LIMITING control setting must be increased.
11. Determine normal or abnormal output stage operation with the COLLECTOR OR DRAIN DCV/VPP/ μ S readouts.

-----CAUTION-----

Do not exceed 1,200 VPP on bipolar outputs or 900 VPP on FET horizontal output transistors.

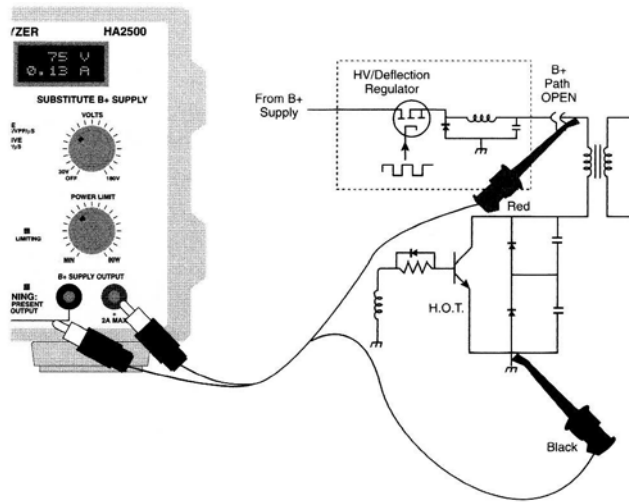

Fig. 3: Connections for substituting for the chassis B+ voltage to the horizontal output stage with the HA2500 Substitute B+ Supply.

Subbing Chassis B+ Voltage To The Horizontal Output Stage

Substitution of the chassis B+ voltage isolates problems to either the horizontal output stage or the high voltage/deflection regulator, or main B+ power supply. Two key circuit points for subbing the chassis B+ supply are the input to the horizontal output stage and the input to the high voltage/deflection regulator. The input of the high voltage deflection regulator corresponds to the output of the main B+ supply.

Subbing the B+ supply voltage to the horizontal output stage isolates symptoms to the B+ power supply of the chassis or the horizontal output stage. Identify the B+ voltage path of the chassis between the output of the HV/deflection regulator and the B+ input pin of the flyback transformer. Refer to the schematic when possible to identify the B+ input to the flyback or horizontal output coil.

If you do not have a schematic you can identify the B+ input pin to the horizontal output stage flyback or coil using a combination of methods. Trace from the collector of the horizontal output transistor to the output coil or flyback transformer. Use an ohmmeter to identify windings with continuity to the collector trace and note components connected to these circuit board traces. The B+ voltage input commonly has a bypass capacitor of 1 to 100 μF at 150 volts or more to

ground. A diode, small value resistor, coil, or trace jumper may be found on the B+ voltage path to this pin. You may use the HA2500's Load Test to further confirm the B+ input. With the chassis power off, perform the Load Tests Setup and Load Tests. Connect the orange clip of the LOAD & RINGER TEST LEAD to suspect B+ input pin(s). Use a trial and error method to locate the pin that provides normal Load Tests Setup and Load Tests results. Normal Load Tests Setup and Load Tests results identify the proper B+ input. If all pins give unusual results, a severe horizontal output stage defect may exist.

Once you have identified the B+ input path to the horizontal output stage flyback or coil, open a coil, resistor, or wire trace jumper to open the B+ voltage path. To further confirm that you have opened the B+ voltage path, connect the DYNAMIC TEST LEAD to the chassis horizontal output stage and monitor the Collector Or Drain DCV readout as you apply AC power to the chassis. A readout near 0 confirms that there is no B+ voltage to the horizontal output stage. A normal DCV readout indicates the B+ path has not been opened.

Substitute the chassis B+ voltage with the Ha2500's Substitute B+ Supply following the steps outlined in this Tech Tip. If the horizontal output stage produces normal Collector Or Drain VPP and μs readouts, the horizontal

output stage is functioning normally. Measure high voltage, focus, or screen voltages to confirm normal output voltages from the horizontal output stage.

If the chassis power supply and signal processing stages are functional, the CRT of the monitor can be used to determine if the horizontal output stage is working properly. Apply a video test generator with the appropriate signal input format and frequency to the display. In a multi-frequency monitor, you should connect the generator before substituting the B+ voltage. The horizontal operating frequency changes the level of B+ voltage needed to produce normal high voltage and/or deflection. Changing the frequency while subbing the chassis B+ voltage may result in excessive horizontal output stage voltages. A near normal video on the CRT indicates normal high voltage and/or deflection is being generated by the horizontal output stage.

Some irregularities may be seen on the CRT when subbing the B+ voltage in working multi-frequency monitors. Opening the B+ voltage path of the chassis reduces the normal load on the switching mode power supply. This often changes the operating condition of the power supply enough to reduce or add noise to the other secondary voltages feeding the remainder of the chassis. Vertical deflection may be reduced or shifted and/or the CRT may be jumpy or contain noises. If these irregularities interfere with diagnoses of difficult problems, they can be offset by adding a load to the chassis B+ power supply. Momentarily connect a resistor between 500 and 1,000 ohms (>20 watts) to the B+ output and ground.

Some chassis perform pincushion correction by modulating the B+ voltage to the horizontal output stage. Substituting the B+ voltage to the horizontal output stage with the HA2500 defeats pincushion corrections in these chassis. Expect the horizontal deflection to narrow in the center compared to the upper and lower parts of the display.

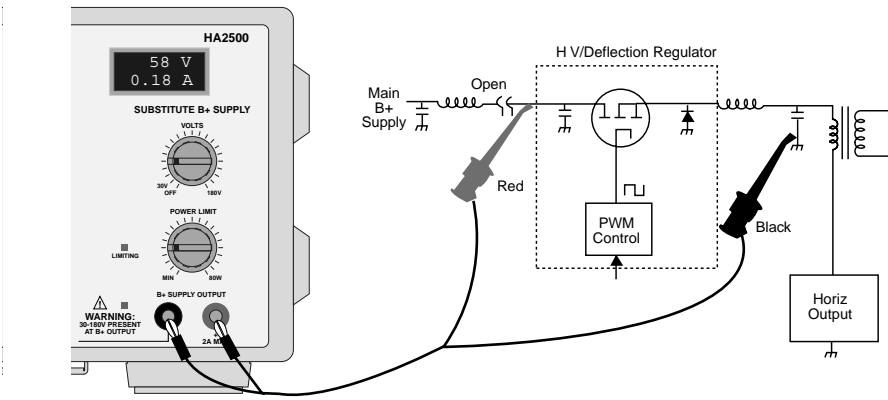

Fig. 4 : Setup for subbing the B+ supply voltage to the input to the HV/Defl. regulator with the HA2500's SUBSTITUTE B+ SUPPLY.

Subbing Chassis B+ Voltage To The HV/Deflection Regulator

HV/deflection regulator defects commonly cause shutdown symptoms, preventing measurements. At other times HV/deflection regulator defects result in high current draw from the main power supply. These defects cannot be easily isolated to the HV/deflection regulator, often causing technicians to suspect and replace horizontal output stage components. Subbing a reduced voltage to the input of the HV/deflection regulator lets you analyze the regulator and horizontal output stage avoiding high currents and shutdowns which prevent measurements or cause component damage.

The B+ voltage output from the main power supply can be identified on the schematic or board by finding the largest DC output voltage or highest DC voltage rated filter capacitor on the output side of the switch mode power supply transformer. Trace the B+ supply output voltage to the high voltage/deflection regulator or horizontal output stage. A coil or jumper may be unsoldered and lifted from the board to open the B+ output voltage path. When opening the B+ voltage path near the switching power supply circuitry, be careful not to open the feedback voltage path for the regulator control of the switch mode power supply.

When substituting B+ to the HV/Deflection regulator, start at a reduced B+ Substitute voltage and slowly increase the voltage.

With the Dynamic Tests leads connected to the horizontal output transistor, monitor the Collector Or Drain DCV/VPP/ μ S readouts. Initially the DCV readout should increase and the VPP readouts should increase as the substitute B+ voltage is increased. At some level of substitution B+ voltage, the DCV and VPP voltages should begin to hold relatively constant. This is the point where the HV/deflection regulator begins to regulate the B+ voltage to the horizontal output stage. This should also be the level that produces normal VPP readings and high voltage and/or deflection.

If when increasing the Substitute B+ voltage, the DCV and VPP readouts continue to increase producing VPP readings nearing 1200 VPP (bipolar

output) or 900 VPP (MOSFET output), the HV/deflection regulator or its controlling circuits are defective. A common defect is a shorted MOSFET switching transistor in the HV/deflection regulator. If the B+ voltage to the horizontal output stage begins to regulate too early, unusually low DCV to the horizontal output stage and low VPP levels result. This HV/deflection regulator or control defect causes reduced high voltage and/or deflection.

If the horizontal output stage functions normally when subbing B+ to the horizontal output stage, but does not when subbing B+ to the HV/deflection regulator, a defect in the regulator exists. Test components associated with the stage to isolate the defect.

Using The Substitute B+ Supply And Sub Drive Together

The Substitute B+ Supply and Base or Gate Sub Drive may be used together to analyze a horizontal output stage. The Sub Drive permits testing of the horizontal output stage when the chassis is not producing horizontal drive to the horizontal output transistor or drive is suspected of being defective. When using the Substitute B+ supply, a missing or defective drive prevents an accurate test of the horizontal output stage. An advantage of using the Substitute B+ Supply and Sub Drive together is that both inputs needed by the horizontal

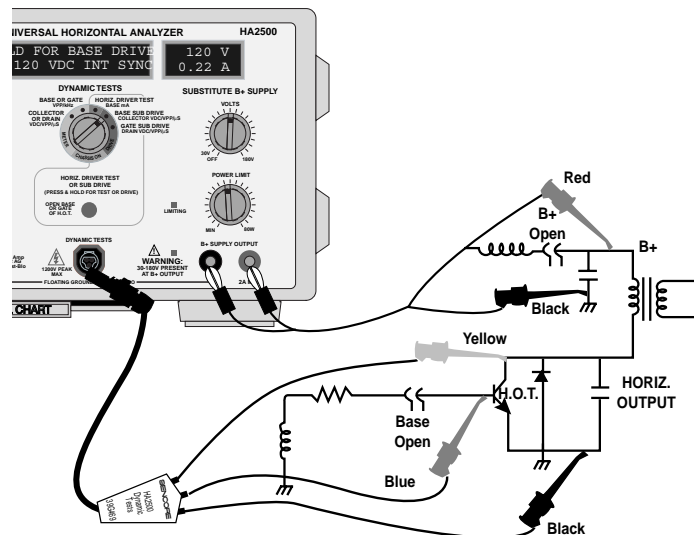

Fig. 5: The SUBSTITUTE B+ SUPPLY and SUB DRIVE may be used together to test the horizontal output stage.

output stage to operate are substituted. This permits analyzing of the horizontal output stage for defects without applying AC voltage to the chassis. Keep in mind that a multi-frequency display should be tested at its highest operating frequency because the mode-switched components typically default to the highest frequency condition.

To simultaneously substitute for the chassis B+ voltage and horizontal drive to the base or gate of the horizontal output transistor, connect the test leads as shown in Fig. 5. Keep in mind that the Substitute B+ Supply and Base Sub Drive both require that circuit paths be opened in either a chassis-on or chassis-off test condition. Open the B+ voltage path and connect the Substitute B+ Supply output to the horizontal output stage side of the

opened path. The Base Sub Drive or Gate Sub Drive requires that the base or gate path for horizontal drive be opened. The base or gate must be opened regardless whether the chassis horizontal drive is missing or present. The circuitry preceding the base or gate alters the operation of the Sub Drive output circuit.

Follow the steps outlined in this Tech Tip to substitute the B+ supply voltage. Before you begin to increase the voltage from the HA2500's Substitute B+ Supply, connect the DYNAMIC TESTS LEADS and select the Base Sub Drive (Bipolar H.O.T) or Gate Sub Drive (MOSFET) Dynamic Test. It is not necessary to apply AC to the monitor. Push the HORIZ. DRIVER TEST OR SUB DRIVE pushbutton to substitute horizontal drive. Monitor the VDC/VPP/ μ S Dynamic Tests readouts as you increase the

Substitute B+ Supply volts. If the horizontal output stage produces normal Collector Or Drain VPP and μ S readouts, the horizontal output stage is functioning normally. Measure high voltage, focus, or screen voltages to confirm normal output voltages from the horizontal output stage.

**For More Information,
Call Toll Free 1-800-SENCORE
(736-2673)**

SENCORE

3200 Sencore Drive, Sioux Falls, SD 57107
Fax: 1-605-339-0317 www.sencore.com