

## Chipper Check Simplified Block Diagram

The Chipper Check interface box from Thomson Consumer Electronics provides an interface for alignments and EEPROM testing with a computer. A simplified block diagram of the internal signal lines and power supply within the Chipper Check interface box are included in this document. These simplified diagrams can help diagnose and troubleshoot Chipper Check defects.

The Chipper Check power supply consists of two separate supplies. The Input Side Supply provides approximately 5 volts to the circuitry on the computer or input side of the Chipper Check. The Output Side Switching Supply provides approximately 5 volts to the circuitry on the output connector side of the Chipper Check. The input side is isolated from the output side by the opto-coupler ICs on each signal line and power supply transformer. All measurements or voltage references on the input side are referenced to S1 ground. All measurement or voltage references on the output side are reference to S ground.

The Power Adapter provides approximately 12 VDC to the Chipper Check interface box. The best indicator of a

working power adapter is an illuminated LED on the Chipper Check box. The Input Side supply consists of two parallel 150 ohm resistors and a 5.1 V zener to produce the 5V output. The voltage is filtered by C28908. A voltage measurement of approximately 5 V across C28908 indicates a good supply.

A more complex switching power supply produces the isolated Output Side Switching Supply 5 volts. IC U28904 forms a drive oscillator producing drive which is amplified to the base of Q28902. Switching action produces current alternating in the transformer. Voltage induced in the secondary is rectified, filtered and applied to the resistor zener diode network to produce approximately 4.8 volts output.

The Chipper Check interface box contains 10 signal lines between the input 36 pin connector to the output side. There are two data return paths from the output side transporting data from the output back to the computer. There are two data input paths transporting data from the computer to the output. There are two clock lines that transport clock signals

#CC5 900#

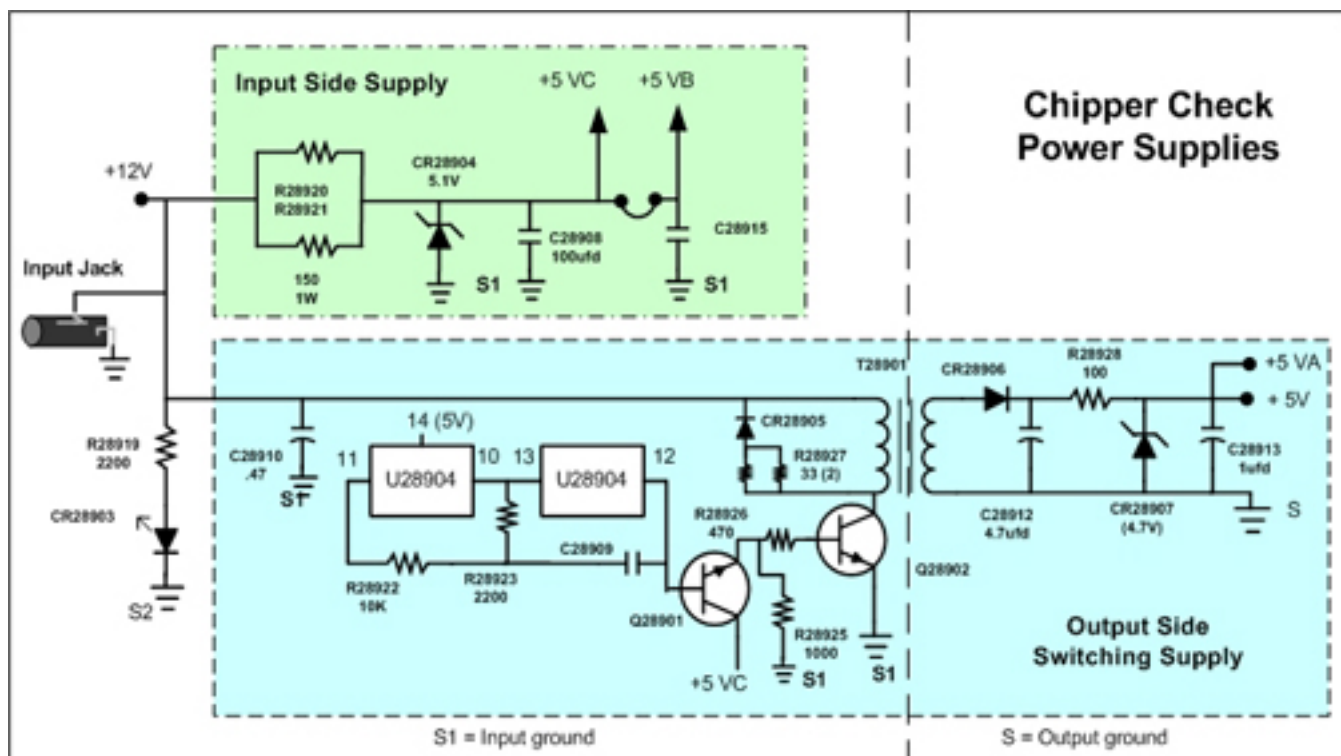

from the computer to the output. An IM Enable line, also referred to as IN Enable, provides a signal line from the computer to the output and TV chassis. Three enable lines

control the clock and data lines during read and write directional activity.

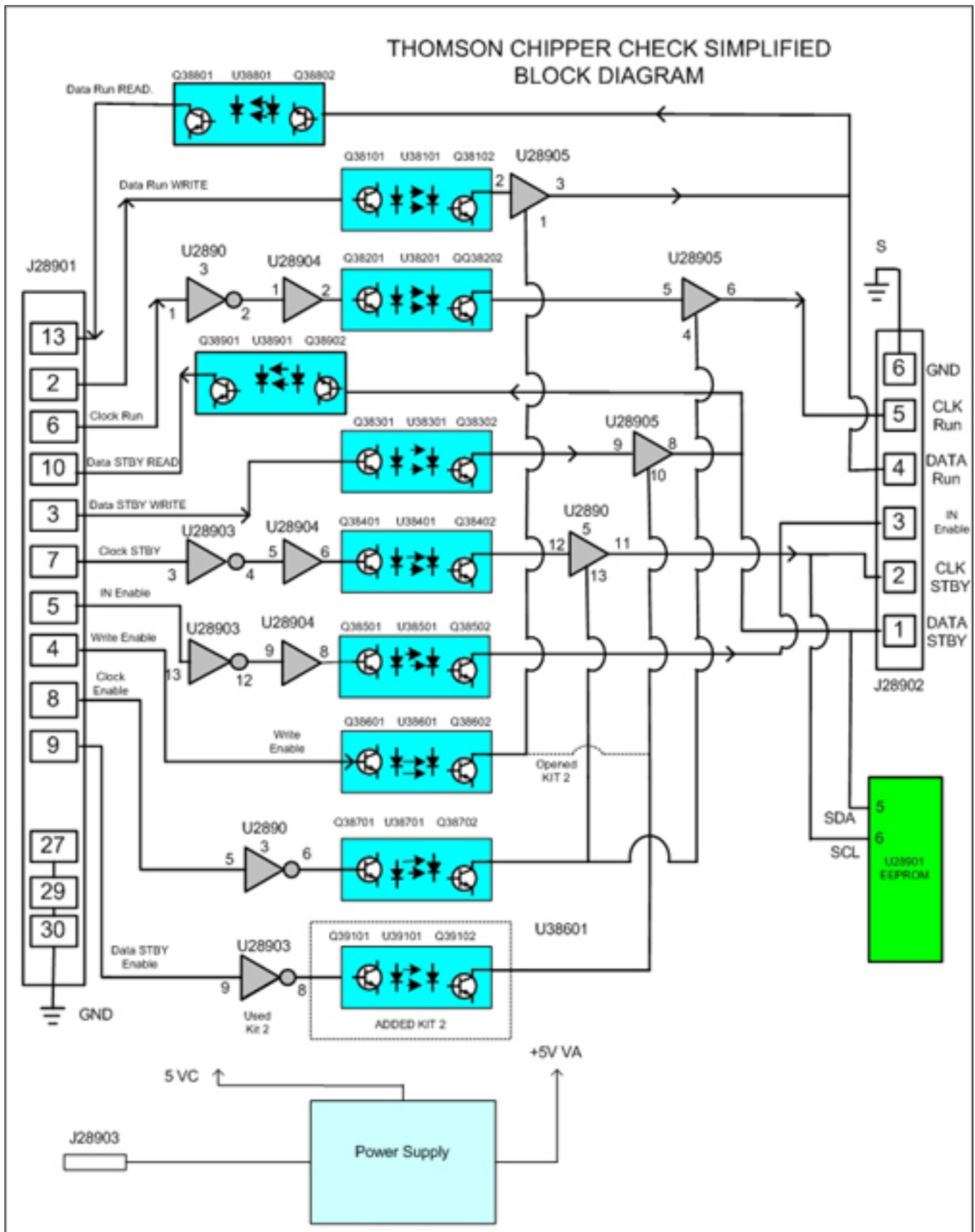

#CC5

#CC5

**For More Information**  
**Call Toll Free 1-800-SENCORE**  
**(1-800-736-2673)**

**SENCORE**

3200 Sencore Drive, Sioux Falls, SD 57107  
[www.sencore.com](http://www.sencore.com)

#CC5

#CC5