

USB Type-C ENGINEERING CHANGE NOTICE

Title: Reference footprint figure 3-5 and 3-8

Applied to: USB Type-C Specification Release 1.0, August 11, 2014

Brief description of the functional changes:

Update Figure 3-5 and 3-8 Reference footprint for a USB Type C Dual Row SMT Top Mount Connector and Hybrid TH and SMT Mid-Mount Connectors. The changes align all dimensioning schemes to be consistent with WG recommendations.
--

Benefits as a result of the changes:

The changes align all dimensioning schemes to be consistent with WG recommendations.
--

An assessment of the impact to the existing revision and systems that currently conform to the USB specification:
--

None.

An analysis of the hardware implications:
--

None.

An analysis of the software implications:
--

None

An analysis of the compliance testing implications:
--

None

USB Type-C ENGINEERING CHANGE NOTICE

(b). Section 3.2.1, Figure 3-8, Page 38
From Graphic:

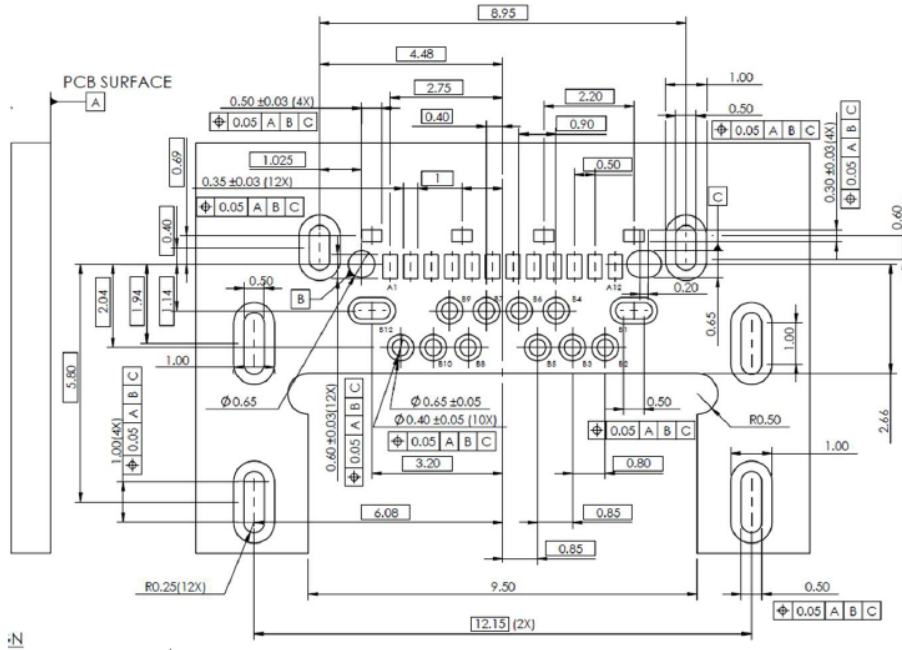

To Graphic:

