

High Pressure Sampling with RGAs

Application Note #8

The types of analysis performed by an RGA are useful in many applications other than vacuum systems. But, the RGA is intrinsically a vacuum instrument that operates best near 10^{-6} mbar. Above 10^{-5} , the response becomes non-linear, and above 10^{-4} the filament will be shut off by the control electronics. To sample gasses at higher pressures, a pressure reduction system is needed. These systems are basically a restriction and a vacuum pump package. Common restrictions are pinholes and capillaries, which can provide pressure reductions of more than six decades. The vacuum pump package consists of a turbomolecular pump and a backing pump. In addition to achieving the desired pressure reduction, the design of a system should provide for a fast response and high signal-to-background ratio.

At pressures common to vacuum processes, a simple aperture-based pressure reduction system is suitable. At atmospheric and higher pressures, a two stage reduction system—based on a capillary and aperture—is used. These two systems will be used to illustrate the design of pressure reduction systems for RGAs.

Vacuum Process Sampling (10 to 10^{-5} mbar)

Figure 1 shows a schematic of a basic pressure reduction system. The system has two paths to the RGA: a high conductance path, and an aperture path. The high conductance path (through valve Hi-C) is provided so that the RGA can monitor the ultimate vacuum of systems before a process begins. The Hi-C path is also used when leak testing the vacuum system with the RGA software's leak test mode. The aperture path provides the pressure reduction needed for operating at pressures up to 10 mbar.

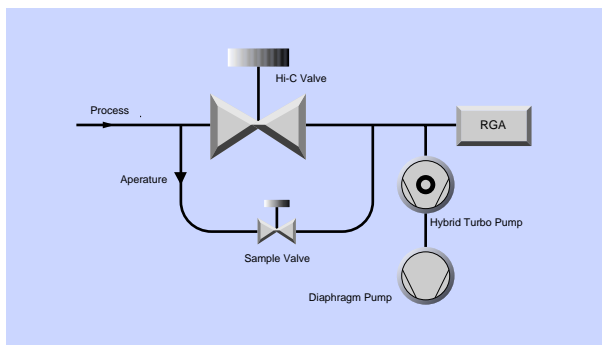

Figure 1: Mid-vacuum pressure reduction system

Apertures can be readily designed for process pressures in the range from 10^{-3} mbar to 10 mbar. If the process always operates within a small range, the aperture can be optimized to deliver gas to the RGA at about 10^{-6} to 10^{-5} mbar. By operating the RGA at its optimum pressure, the data acquisition time is kept to a minimum, and the full dynamic range in partial pressure is available. For many applications, the process is operated at one pressure, and the aperture can be optimized. If the process pressure varies over a range of two

decades or more, the aperture size must be compromised to tolerate the pressure range. For example, consider a process pressure that varies from 10^{-1} to 10 mbar. The aperture would be designed to drop the pressure from 10 mbar to 10^{-5} mbar. When the process pressure was at 10^{-1} mbar, the pressure at the RGA would be 10^{-7} mbar. The noise floor of the RGA does not depend on the process pressure: for a Faraday cup detector it is about 10^{-10} mbar. Therefore, the dynamic range of the measurement varies from five decades at high process pressure to only three decades at the low pressures. For applications where the full dynamic range is not needed, operating the RGA at low pressure may be acceptable. If the full dynamic range is required over a variety of process pressures, a variable reduction is required. Suitable variable leak valves are available but are significantly more expensive than a fixed aperture.

Another method of increasing the dynamic range and data acquisition rate is to use an RGA with an electron multiplier. The electron multiplier provides gains from 10^2 to 10^6 and lowers the noise floor to as low as 10^{-14} mbar. This lower noise floor allows the RGA to provide large dynamic range: even at low operating pressures.

A high operating pressure (or throughput of the aperture) at the RGA also improves the signal-to-background ratio. In this context, "signal" is the gas that is drawn through the aperture, and "background" is outgassing from the system plus backstreaming through the turbo pump. The ultimate vacuum

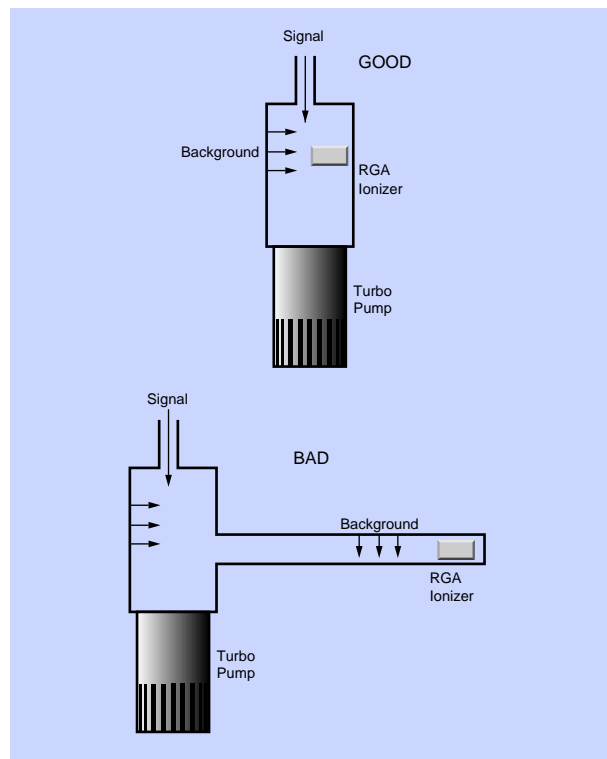

Figure 2: Layouts of post-aperture vacuum systems

of many turbo pump packages is about 10^{-9} mbar. The outgassing background will be mostly hydrogen, water and nitrogen. The backstreaming background will be air. If measurements are being made near these background peaks, the operating pressure should be kept as high as possible. The background can be minimized by designing the tubing such that the effective pumping speed at the RGA ionizer is as high as possible. Figure 2 shows two layouts that both have the same "signal" level. The layout with the RGA at the end of a small tube has a small effective pumping speed and will show a larger background level.

The system shown in Figure 1 can be assembled as a simple package. Choosing a small (70 liter/s or less) hybrid turbo pump and a diaphragm backing pump will eliminate any concern of oil. The use of this pump pair also eliminates foreline traps and isolation valves. The operation of the system should be simple: open the Hi-C valve at low pressures, or open the sample valve at high pressures.

High Pressure Sampling (>100 mbar)

At high pressure, the aperture assembly is insufficient to reduce the pressure while maintaining response time. Consider an aperture that reduces the pressure from 10 mbar to 10^{-6} mbar when used with a 70 liter/s turbo pump. The volumetric flow rate on the high pressure side of the aperture would be 7 microliter/s. Any dead volume on the high pressure side of the aperture (Figure 3) would cause a large response time-constant ($t_c = \text{volume}/\text{flow rate}$). If the aperture had a small dead volume of 1/2 inch of 0.250 OD tube (0.028 wall), the time constant would be 35 seconds. This is not an acceptable response time.

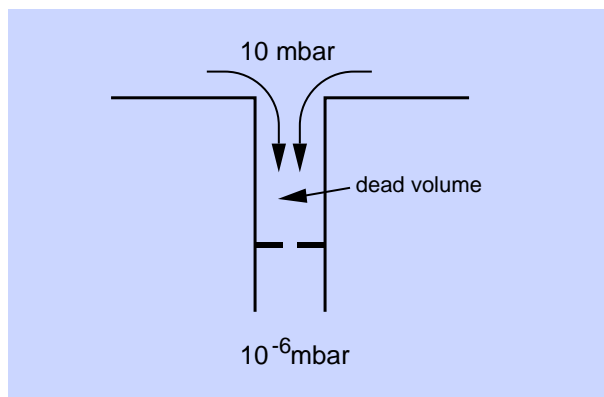

Figure 3: Small dead volume slows process response time

To achieve a fast response time, a capillary inlet is used with bypass pumping as shown in Figure 4. The system reduces the pressure in two stages. Most of the sampled gas is drawn through the capillary and directly to the diaphragm pump, bypassing the RGA. The pressure at the exit of the capillary is about 1 mbar. A small amount of the sampled gas is diverted to the RGA through an aperture. This configuration improves the response time in two ways. First, the pressure on the high side of the aperture is held to about 1 mbar. But even this

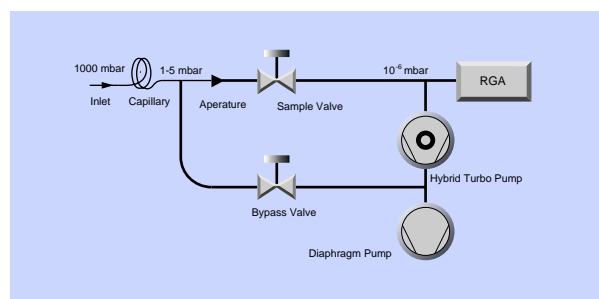

Figure 4: High pressure sampling

pressure would give a time constant of 3.5 seconds in the 1/2 inch dead-volume example mentioned above. The second method to decrease the time constant is to ensure that any dead volume is well mixed. After the capillary, the gas is traveling at significant velocity (several meters per second). Proper layout of the inlet tubing will use the kinetic energy of the sampled gas to mix the dead volume (in a sense keeping the volume alive). Figure 5 shows the response to bursts of gas at the inlet of an atmospheric sampler designed with the above considerations. The sub-second response and cleanup are almost as fast as the RGA data rate.

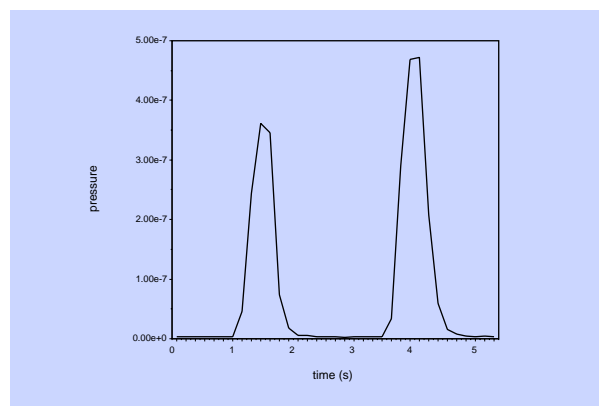

Figure 5: Response of bypass pumped system to gas bursts

Glass capillaries are available with small enough bores to reduce pressure from 1000 mbar to 10^{-6} mbar without bypass pumping. While it is possible to build an atmospheric sampling system based on a 1/4 meter 50 mm glass capillary, there are considerable reasons to use a bypass pump configuration. Bypass pumping improves the operation of a system by increasing the flow rate of gas through the capillary about 3 to 4 orders of magnitude. The higher flow rates and smaller pressure drop allow a wider selection of capillaries to be practical. Stainless steel and PEEK capillaries are more affordable and flexible than glass capillaries. A large flow rate means that the volumetric flow rate at the inlet of the capillary is more reasonable. For a system with 70 liter/s pumping speed, operating at 10^{-6} mbar, the volumetric flow rate at the inlet would be 70 nliter/s. Any dead volume at the inlet of the capillary would result in an unreasonable response time. With such small flow rates, inlet devices such as filters, valves, or

connecting hardware cannot be used. Overall, the bypass-pumped capillary system is more flexible and only requires a minor addition of hardware (one valve and some tube).

The configuration seen in Figure 4 is made possible by the recent advances in hybrid turbomolecular/drag pumps and diaphragm pumps. Traditional designs would have relied on two rotary-vane pumps and standard turbomolecular pump. The high compression ratios of the hybrid turbo pumps allow the two stream (bypass and sample) to be combined. The low ultimate vacuum of contemporary diaphragm pumps makes them suitable as a foreline pump. The combination of these modern technologies means that an atmospheric sampling system can be constructed into very small packages (less than 8 inch high in a 19 inch rack mount chassis), which are portable and easy to operate.

Conclusion

Although the RGA is intrinsically a vacuum instrument, inlet systems are easily designed that allow it to sample gases at any pressure. A more descriptive name for such systems would be "online quadrupole mass spectrometer". Mass spectrometry is a well proven analytical technique, but traditionally has been expensive and required large machines. Reduction in cost of quadrupoles and vacuum pumps, along with the development of easy to use software interfaces, makes process analysis with mass spectrometry an attractive technique.