

Temperature monitoring and protection

Design considerations for smarter, smaller and high-accuracy temperature sensors to enable enhanced system performance and control.

Table of contents

Preface

Message from the editors	3
Additional resources to explore	4

Chapter 1: Temperature sensing fundamentals

Introduction	5
------------------------	---

Chapter 2: System temperature monitoring

Section 2.1 How to monitor board temperature	7
Section 2.2 High-performance processor die temperature monitoring	9

Chapter 3: Ambient temperature monitoring

Section 3.1 Layout considerations for accurately measuring ambient temperature	12
Section 3.2 Efficient cold-chain management with scalable temperature sensors	14

Chapter 4: Body temperature monitoring

Design challenges of wearable temperature sensing	17
---	----

Chapter 5: Fluid temperature monitoring

RTD replacement in heat meters using digital temperature sensors	20
--	----

Chapter 6: Threshold detection

How to protect control systems from thermal damage	23
--	----

Chapter 7: Temperature compensation and calibration

Section 7.1 Temperature compensation using high-accuracy temperature sensors	26
Section 7.2 Methods to calibrate temperature monitoring systems	28

Introduction

In designing personal electronics, industrial or medical applications, engineers must address some of the same challenges: how to increase performance, add features and shrink form factors. Along with these considerations, they must carefully monitor temperature to ensure safety and protect systems and consumers from harm.

Another trend spanning numerous industries is the need to process more data from more sensors, further necessitating the importance of temperature measurement—not just to measure system or environmental conditions, but to compensate for other temperature-sensitive components in order to maintain both sensor and system accuracy. As an added benefit, accurate temperature monitoring can increase system performance and reduce costs by removing the need to overdesign systems to compensate for inaccurate temperature measurements.

Temperature design challenges fall into three categories:

- **Temperature monitoring:** Temperature sensors provide valuable data for continuously tracking thermal conditions, and provide feedback to control systems. This can be system temperature monitoring or environmental temperature monitoring. In several applications we can see design challenges where both are required to be implemented in the control loop. These include system temperature monitoring, ambient temperature monitoring and body or fluid temperature monitoring.
- **Temperature protection:** Several applications require action once the system goes above or below functional temperature thresholds. Temperature sensors provide output alerts upon the detection of defined conditions to prevent system damage. It is possible to enhance processor throughput without compromising system reliability. Systems often initiate a safe thermal shutdown too soon, effectively losing up to 5°C or even 10°C of performance. When the system goes above or below functional temperature thresholds, engineers can autonomously initiate actions for real-time protection.
- **Temperature compensation:** Temperature sensors can maximize the performance of a system as temperature changes during normal operations. Monitoring and correcting the drift of other critical components as they heat up and cool down reduces the risk of system failure.

This e-book features TI application briefs that present design considerations for various applications using different temperature-sensing technologies. The chapters first describe the main temperature challenges, followed by a focus on design considerations for applications, assessing trade-offs between temperature accuracy and application size while considering sensor placement.

If you have feedback about the topics covered here or any other temperature monitoring and protection questions, please submit them to the [Sensors forum](#) on the TI E2E™ Community.

TI temperature sensors

<http://www.ti.com/sensors/temperature-sensors/overview.html>

- View the entire portfolio of innovative high-accuracy and small-size thermal monitoring and protection sensors.

Temperature sensors parametric quick search

<http://www.ti.com/sensors/temperature-sensors/products.html>

- Find your next high-accuracy or small-size temperature sensor.

TI Precision Labs video training

<https://training.ti.com/ti-precision-labs-temperature-sensors>

- TI Precision Labs is the most comprehensive online classroom for analog signal chain designers. The training series includes videos, downloadable reference materials and on-demand courses and tutorials, ranging from introductory to advanced concepts that focus on application-specific problem-solving.

Reference designs

<http://www.ti.com/sensors/temperature-sensors/reference-designs.html#search?famid=611>

- Ready-to-use reference designs with theory, calculations, simulation schematics, printed circuit board (PCB) files and test-bench results.

Analog Wire blog

http://e2e.ti.com/blogs_/b/analogwire

- Technical articles written by analog experts that include tips, tricks and design techniques.

TI E2E™ Community

<http://e2e.ti.com/>

- Support forums for all TI products.

Analog Engineer's Pocket Reference

<https://www.ti.com/seclit/ml/slyw038c/slyw038c.pdf>

- PCB, analog and mixed-signal design formula, including conversions, tables and equations available as an e-book, hard copy or iTunes app.

TINA-TI™ simulation software

<http://www.ti.com/tool/TINA-TI>

- Complete SPICE simulator for DC, AC, transient and noise analysis, including schematic entry fields and a post-processor for waveform math.

Analog engineer's calculator

<http://www.ti.com/tool/ANALOG-ENGINEER-CALC>

- Analog-to-digital converter and amplifier design tools, noise and stability analysis, PCB and sensor tools.

Chapter 1: Temperature sensing fundamentals

Introduction

In embedded systems, there is constant demand for higher performance and more features in a smaller form factor. This demand requires that designers monitor the overall temperature to ensure safety and protect systems. Integrating more sensors in applications further drives the need for temperature measurement to not only measure system or environmental conditions, but to compensate for temperature-sensitive components and maintain total system accuracy.

Temperature design considerations

Considerations for efficient temperature monitoring and protection include:

- **Accuracy.** Sensor accuracy represents how close the temperature is to the true value. In determining accuracy, it is important to consider all factors, including acquisition circuitry and linearity across the operating temperature range.
- **Size.** While the size of the sensor makes an impact on the design, analyzing the overall circuit can yield a more optimized design. Sensor size also determines the thermal response time, which can be important for applications like body temperature monitoring.
- **Sensor placement.** Package and placement can impact the response time and conduction path; both are critical for effective temperature design.

Common temperature sensor technologies in the Industry include integrated circuit (IC) sensors, thermistors, RTDs and thermocouples. **Table 1** compares key features to use when assessing the right technology for the design challenge.

	IC sensors	Thermistors	RTDs	Thermocouples
Range	-55°C to +200°C	-100°C to +500°C	-240°C to 600°C	-260°C to +2,300°C
Accuracy	Good/best	Calibration-dependent	Best	Better
Footprint/size	Smallest	Small	Moderate	Large
Complexity	Easy	Moderate	Complex	Complex
Linearity	Best	Low	Best	Better
Topology	Point-to-point, multidrop, daisy chain	Point-to-point	Point-to-point	Point-to-point
Price	Low to moderate	Low to moderate	Expensive	Expensive

Table 1: Comparing temperature sensing technologies.

IC sensors

IC temperature sensors rely on the predictive temperature dependence of a silicon band gap. As shown in **Figure 1** and **Equation 1**, the precision current sources the internal forward-biased P-N junction with the resulting base-to-emitter voltage change (ΔV_{BE}) that corresponds to the device temperature.

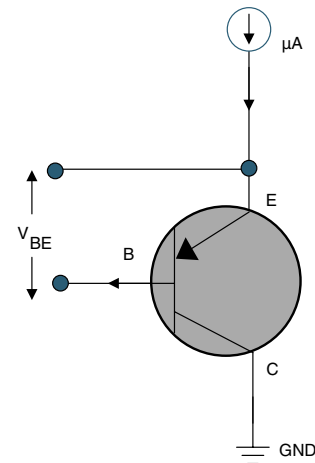

Figure 1: Temperature dependence of a silicon band gap.

$$\Delta V_{BE} = \frac{KT}{q} \times \ln\left(\frac{I_{C1}}{I_{C2}}\right)$$

Equation 1: Temperature dependence of the band gap of silicon.

Given the predictable behavior of silicon, ICs offer high linearity and accuracy (up to $\pm 0.1^\circ\text{C}$) across a wide temperature range. These sensors can integrate system functionalities such as analog-to-digital converters (ADCs) or comparators that ultimately reduce system complexity and offer an overall smaller footprint. They

are typically available in surface-mount and through-hole packaging.

Thermistors

Thermistors are passive components, with a resistance greatly dependent upon temperature. Thermistors fall into two categories: positive temperature coefficient (PTC) and negative temperature coefficient (NTC).

Although thermistors offer a variety of package options for on-board and off-board temperature sensing, the typical implementation requires more system components compared to an IC sensor. Silicon-based PTC thermistors offer linearity, while NTC thermistors are nonlinear and often have increased calibration costs and software overhead.

Figure 2 shows a typical thermistor implementation. It is often difficult to determine true system accuracy for thermistors. NTC system error contributors include NTC tolerance; the bias resistor, which is susceptible to temperature drift; the ADC, which can cause quantization errors; the linearization errors inherent to NTCs; and the reference voltage.

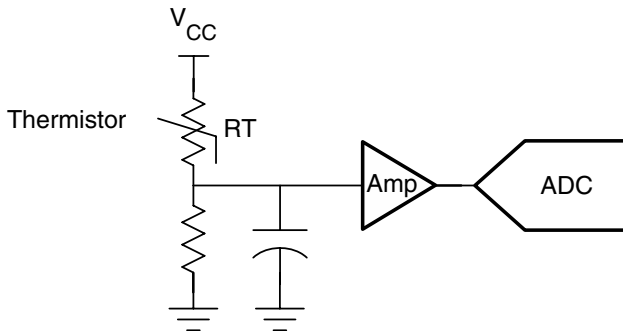

Figure 2: Typical thermistor implementation.

RTDs

RTDs are temperature sensors made of a pure material like platinum, nickel or copper, with a highly predictable resistance/temperature relationship.

Platinum RTDs can be highly accurate and very linear across a very wide temperature range up to 600°C. As shown in **Figure 3**, an implementation with analog sensors involves complex circuitry and design challenges. Ultimately, accurate systems involve complex error analysis because of the higher number of contributing components, which also impact overall system size. RTDs also require calibration during manufacturing, followed by annual calibration in the field.

RTD system error contributors include RTD tolerance, self-heating, ADC quantization errors and references.

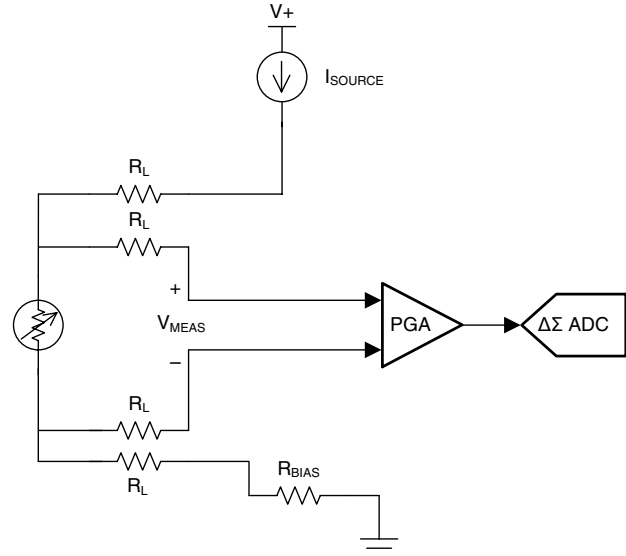

Figure 3: Complex four-wire RTD circuit.

Thermocouples

Thermocouples are made of two dissimilar electrical conductors that form electrical junctions at different temperatures. A thermocouple produces a temperature-dependent voltage as a result of the thermoelectric Seebeck effect. This voltage translates to the difference in temperature between the hot junction and cold junction.

You must know the temperature of the cold junction in order to derive the hot junction temperature. Here, accuracy is limited by the fact that there are two systems that have separate tolerances and capabilities interacting with each other. **Figure 4** shows a typical CJC implementation with a thermocouple and an external sensor to determine the hot junction temperature.

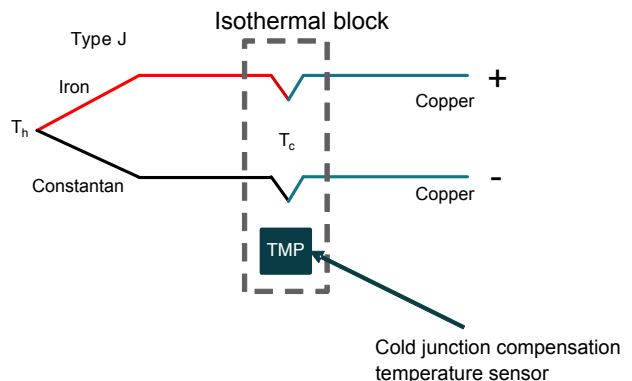

Figure 4: Thermocouple with a cold-junction-compensation (CJC) temperature sensor.

Chapter 2: System temperature monitoring

For many system designs, it is necessary to monitor high-power components (processors, field-programmable gate arrays, field-effect transistors) to ensure system and user safety. Accuracy of the temperature reading is important, as it enables designers to push performance closer to safety limits or reduce system costs by avoiding over-designing elsewhere. The Texas Instruments (TI) portfolio of accurate compact temperature sensors enables the closest placement to these critical components for the most accurate measurements.

Section 2.1

How to monitor board temperature

Introduction

Temperature issues in circuits can impact system performance and damage expensive components. Measuring the temperature of a printed circuit board (PCB) in sections where there are hot spots or power-hungry integrated circuits (ICs) can help identify thermal issues to take preventive or corrective action in real time.

You may want to monitor the die temperature of a power-hungry IC—such as a central processing unit, application-specific IC, field-programmable gate array or digital signal processor—to dynamically adjust its performance, or you may want to monitor hot sections around power stages to either control the fan speed in a system or initiate a safe system shutdown.

The ultimate goal is to optimize performance and protect costly devices. **Figure 1** shows a

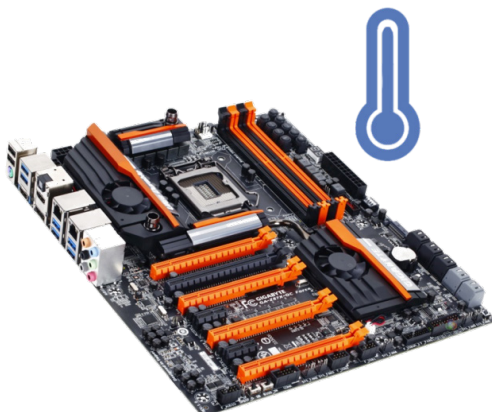

Figure 1: Temperature monitoring on a complex PCB.

temperature-monitoring system on a high-performance computer board.

Heat transfer from the PCB to the temperature sensor

Local temperature sensors measure their own die temperature to determine the temperature in a specific area. Therefore, it is important to understand the dominant temperature conduction paths between the die and the object or environment around the sensor. Heat conducts primarily through two path types: through a die-attach pad (DAP) attached to the package (**Figure 2**) or through the package lead pins. The DAP, if present, provides the most dominant thermal path between the PCB and the die.

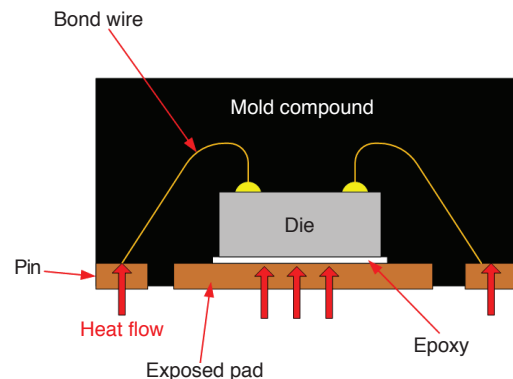

Figure 2: Package with a DAP.

The leads and pins provide the most significant thermal path if the package type does not include a DAP (**Figure 3**).

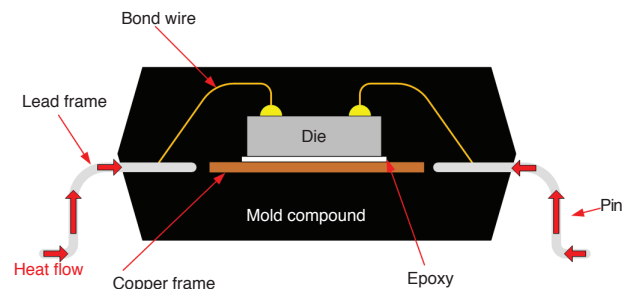

Figure 3: Package without a DAP.

The mold compound provides an additional thermal path, but due to its low thermal conductivity, any heat transfer through the mold compound itself is slower than the heat transfer through the leads or DAP.

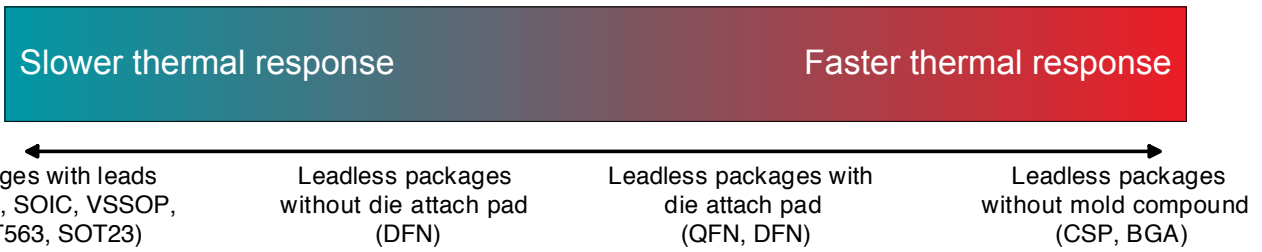

Figure 4: Thermal response chart.

Thermal response

Package type determines how quickly the temperature sensor can respond to changes in temperature. **Figure 4** shows the relative thermal response rates of different classes of selected surface-mount technology package types used for temperature measurements.

Packages without a mold compound (chip-scale package, die-size ball-grid array) and packages with a DAP (quad flat no-lead [QFN], dual flat no-lead [DFN]) are designed for applications that require fast thermal heat transfer from the PCB, while packages without a DAP are designed for applications that require slower response rates. A fast thermal response rate enables the temperature sensor to respond to any temperature changes quickly, and therefore provide an accurate reading.

Design guidelines—bottom-side mounting

The sensor location should be as close as possible to the heat source you want to monitor. Avoid perforations or slits in the PCB between the heat-generating IC and

the temperature sensor, because they could reduce or stop the thermal response. If possible, mount the temperature monitor on the bottom side of the PCB directly below the heat source, as shown in **Figure 5**.

TI recommends using vias to transfer heat quickly from one side of the PCB to the other, because vias have a better thermal conductivity of copper compared to FR-4. You can use as many parallel vias or filled conductive vias as feasible to transfer heat from the heat source to the temperature monitor in order to create fast thermal equilibrium between the two ICs. A QFN or DFN package with a DAP can further help decrease the thermal resistance path between the vias and the sensor die.

Design guidelines—ground plane considerations

If it is not practical or cost-effective to place the temperature sensor on the opposite side of the heat source, place it on the same side as close to the heat source as possible, as shown in **Figure 6**.

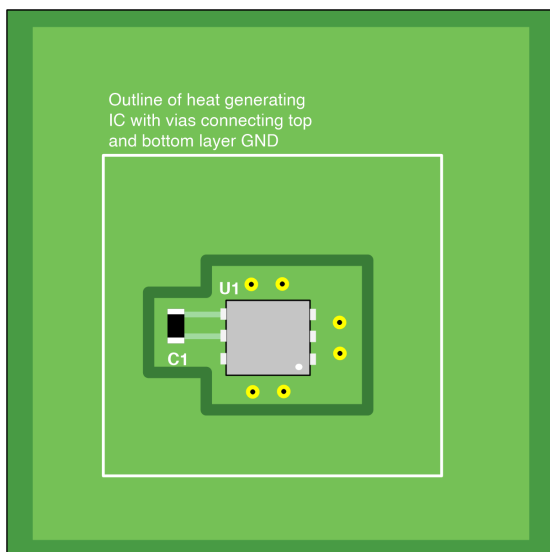

Figure 5: Sensor mounted on the opposite side of the heat source.

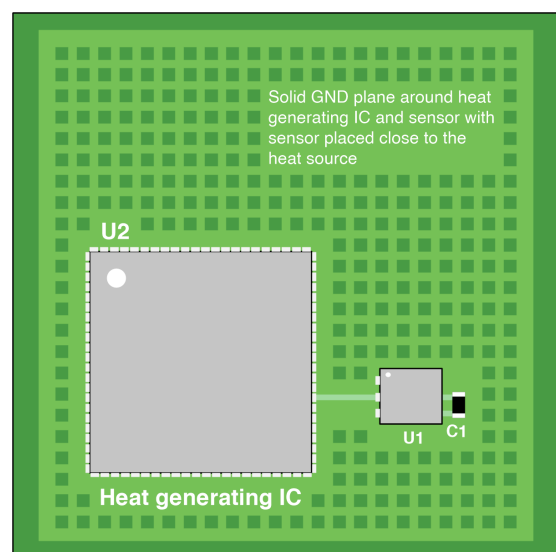

Figure 6: A shared ground plane helps with thermal equilibrium.

The most effective way to create thermal equilibrium between the heat source and the temperature monitor is through the use of a ground plane. Use a solid ground plane that extends from the heat source to the temperature sensor.

Conclusion

Temperature monitoring is critical in PCB designs that have hot power sections or power-hungry ICs. You must evaluate whether the selection of local temperature sensors will meet the system requirements and protection schemes of your design.

Consider the sensor location and the high thermal conductivity path to create fast thermal equilibrium between the sensor and heat-generating element.

Table 1 lists an additional resource with layout recommendations.

Resource	Title
Application report	Temperature sensors: PCB guidelines for surface mount devices

Table 1: Related TI content.

Section 2.2

High-performance processor die temperature monitoring

Introduction

Power management in high-performance processors, such as central processing units (CPUs), graphics processing units (GPU), application-specific integrated circuits (ASIC) and field-programmable gate arrays (FPGAs) is typically complex. With thermal monitoring, these systems can not only initiate a safe system shutdown but also leverage temperature to dynamically adjust performance.

Monitoring process temperatures can enhance system reliability and maximize performance. As shown in **Figure 1**, high-performance processors typically use a heat sink to absorb excessive heat from the die. Higher temperatures can activate a cooling fan, modify a system clock, or—should the processor exceed its temperature threshold—quickly shut down the system.

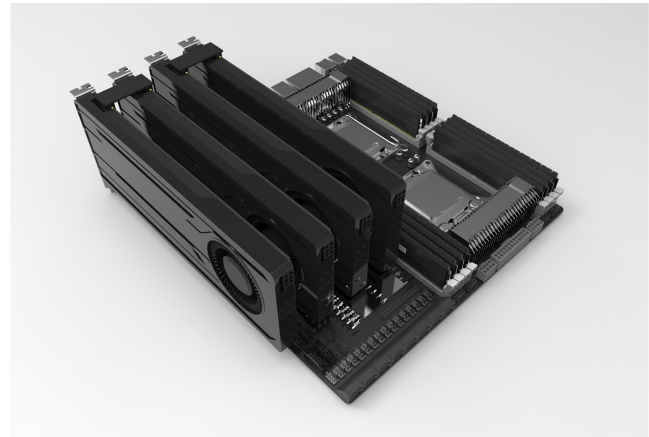

Figure 1. A motherboard with high-performance processors typically needs a heat sink.

Design considerations in die temperature monitoring

For effective temperature monitoring, there are two design considerations for high-performance processors: temperature accuracy and sensor placement. A processor’s temperature accuracy directly correlates to sensor locations.

As shown in **Figure 2**, it’s possible to maximize processor performance to drive systems to their temperature design limits through high-accuracy temperature monitoring. While most integrated circuits have built-in temperature sensors, the accuracy of these sensors is not consistent because of variations among wafers and other various lots. Additionally, it is essential to trim the processor based on a reference in order to adjust the coefficients when compared to the die temperature. High-performance processors inherently

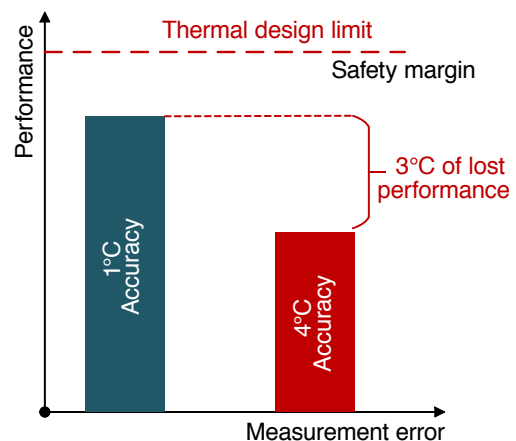

Figure 2. Enhancing system performance through high-accuracy thermal monitoring.

have complex circuitry and incur self-heating that builds temperature errors which increase with temperature. Designing systems with low accuracy and temperature error would not be able to maximize the performance of system to its thermal design limit.

Sensor placement and accuracy

Either an integrated temperature sensor or temperature diode or external temperature sensor can monitor processor thermal behavior. In some cases, using both internal and external sensors can maximize system performance and boost reliability.

Bipolar junction transistor integrated temperature sensors

Some high-performance processors include a bipolar junction transistor (BJT) for temperature sensing. A BJT has a very predictable transfer function that depends on temperature. Remote temperature sensors use this principle to measure the die temperature. The most common BJT found in complementary metal-oxide semiconductor processes is a P-channel N-channel P-channel (PNP). **Figure 3** shows a remote temperature monitoring circuit that measures a PNP transistor-connected configuration.

Designing remote temperature monitoring systems can be challenging due to the noise and error caused due by variations across wafers and different lots. Temperature diode error sources could be caused by:

- **Ideality factor variation.** BJT temperature diode characteristics depend on process geometry and other process variables. If you know the ideality factor, n , you could use an n -factor register to correct

the n -factor error. Alternatively, software calibration methods can correct ideality factor variation in the desired temperature range.

- **Series resistance.** Due to the current source, any resistance in the signal path will appear as a voltage offset. Modern remote temperature sensors employ a series resistance algorithm that removes temperature errors caused by resistance up to 1–2 k Ω . This algorithm enables robust, accurate measurements even when coupled with resistor-capacitor filters.
- **Noise injection.** Electromagnetic interference or inductive coupling into remote junction printed circuit board traces can cause errors when the diode traces run in parallel with high-frequency signal lines carrying high currents. This is one of the most important board design considerations for remote temperature sensors.
- **Beta compensation.** Temperature transistors integrated into an FPGA or processor may have $\beta < 1$. A remote temperature sensor with beta compensation is specifically designed to work with these transistors and to correct temperature measurement errors associated with them. The beta compensation feature provides no benefit when used with a discrete transistor.

Device recommendations

The TMP421 offers a single channel to monitor a BJT; there are also multichannel remote temperature sensors that support as many as eight channels to measure temperature locally and remotely.

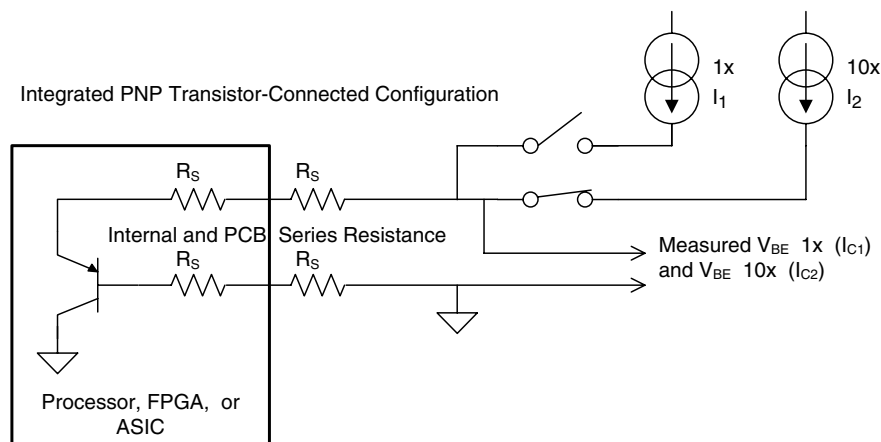

Figure 3. Measuring the base-to-emitter voltage change (ΔV_{BE}) with two currents.

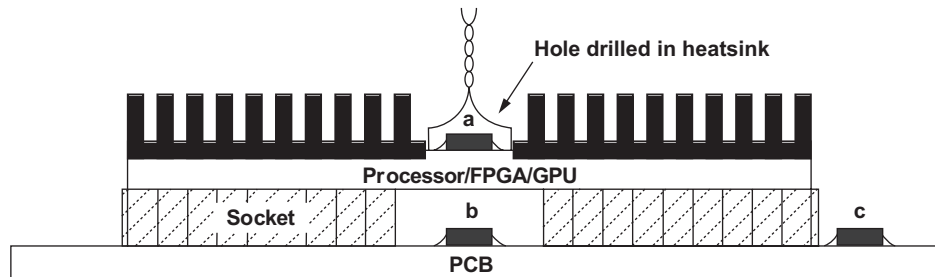

Figure 4. Sensor placement for high-performance-processor temperature monitoring.

The TMP451 offers high-accuracy (0.0625°C) temperature measurement both locally and remotely. Servers, notebooks and automotive sensor fusion applications can benefit from multichannel remote sensors.

External temperature sensors

While a built-in temperature sensor location is best, their accuracy is as low as ±5°C. Adding external, local temperature sensors instead improves die temperature accuracy and improves system performance. You can also use local temperature sensors when integrated die temperature sensors are not available. With local temperature sensors, however, sensor location is an important design consideration. **Figure 4** shows some options—locations a, b and c—for local temperature sensor placement.

- **Location a.** A sensor located in a hole drilled into the center of the microprocessor’s heat sink provides close proximity to the die. The heat sink could be clipped to the processor or attached with epoxy on top of the processor. Temperature sensors in this location typically require long leads, and as the heat sink-to-microprocessor thermal connection degrades, the sensor data will be incorrect.
- **Location b.** Another potential location for a sensor is in the cavity beneath a socketed processor, with which assembly is straightforward. Given that the sensor is isolated from the airflow, the ambient temperature has minimal impact on the sensor

reading. Additionally, if the heat sink detaches from the processor, the sensor will indicate an increase in processor temperature. That said, given this sensor placement, the temperature differences between the sensor and the processor could be from 5°C to 10°C.

- **Location c.** The sensor can be mounted on the circuit board next to the microprocessor unit (MPU). While simple to implement, the correlation between sensor temperature and MPU temperature is much weaker.

Device recommendation

Footprint size is a factor in selecting a local temperature sensor. The TMP112 is available in a 1.6-mm-by-1.6-mm package and can be used in close proximity to a processor. The TMP112 device’s 0.5°C accuracy can maximize performance when compared to the 5°C to 20°C typically observed in temperature sensors integrated within processors.

For additional resources in designing die temperature monitoring applications with remote temperature sensors and external temperature monitoring, see **Table 1**.

Resource	Title
Application report	Optimizing remote diode temperature sensor design
Application report	Temperature sensors: PCB guidelines for surface mount devices

Table 1: Related TI content.

Chapter 3: Ambient temperature monitoring

Ambient air-temperature monitoring is critical in many applications to control environmental conditions or ensure safe operating conditions. Accurately and quickly measuring ambient temperature can often be a challenge because the sensor may not be completely exposed to the external environment, and may be subject to self-heating effects from other components in the system. TI's high-accuracy, low-power single and multichannel temperature sensors in compact packages enable a faster thermal response.

Section 3.1

Layout considerations for accurately measuring ambient temperature

Introduction

Measuring ambient temperature with a surface-mount device can be challenging, because the heat transfer from other power-hungry electronic components can influence the temperature reading of the sensor.

To accurately measure the ambient temperature, it is important to follow good layout techniques, such as understanding the dominant thermal path, isolating the sensor package and placing the device away from interfering heat sources. **Figure 1** shows a simple thermostat design using these techniques.

In **Figure 1**, the passive air flow from the self-heating of the system draws external air over temperature sensor A. The sensor is placed at the intake vent away from the main heat source—the central processing unit—and is thermally isolated for a more accurate measurement.

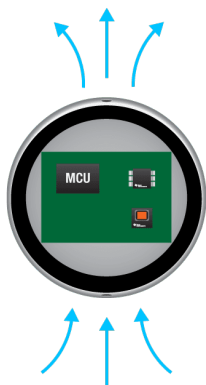

Figure 1. Temperature sensor thermostat design heat radiation and printed circuit board (PCB) layouts.

Heat radiation and PCB layouts

It is important to know which components radiate the most heat first in order to avoid routing traces near heat sources. **Figure 2** is a thermal image captured with the FloTHERM thermal analysis tool from Mentor Graphics, showing the temperature distribution through the air from a heat source.

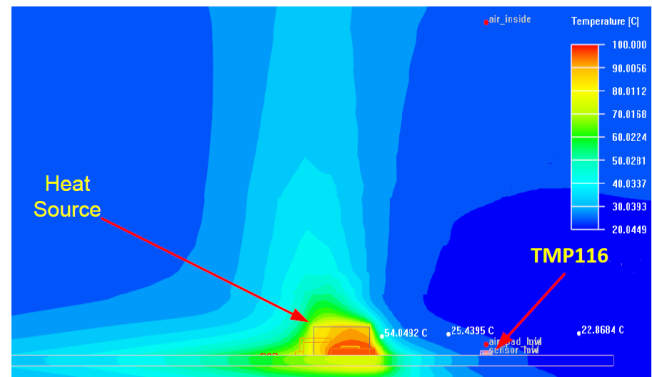

Figure 2. Heat radiated across a test board.

If placing components within an enclosure, the heat distribution may be more condensed. Remember to place the temperature sensor away from the heat source to avoid erroneous temperature readings in both open-air setups and enclosures.

Table 1 lists the recommended distances between sensors and heat sources for various heat source temperatures.

Heat source temperature	Ambient temperature	Recommended distance
40°C	20°C	7.62 mm
60°C	20°C	15.24 mm
100°C	20°C	38.1 mm

Table 1: Recommended distances away from heat sources.

If the sensor is close to the heat source, it is good practice to create an isolation island and maximize the air gap between the sensor and heat source. The bigger the air gap, the better the ambient temperature measurement. When the sensor is further away, however, the gap does not provide additional shielding. The gap may improve the thermal response time of the sensor, though.

Figure 3 shows a 0.8-mm-wide cutout with a temperature reading of about 38.5°C, while **Figure 4** shows a 1.8-mm-wide cutout with a temperature reading of about 35.5°C. These images show how a larger isolation gap affects the ambient temperature reading.

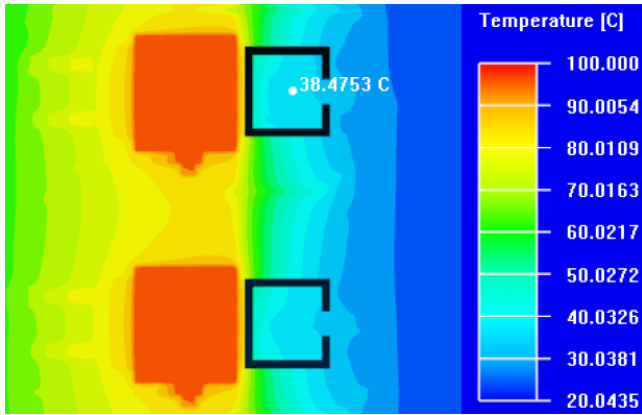

Figure 3. Thermal air gap with a 0.8-mm slot width.

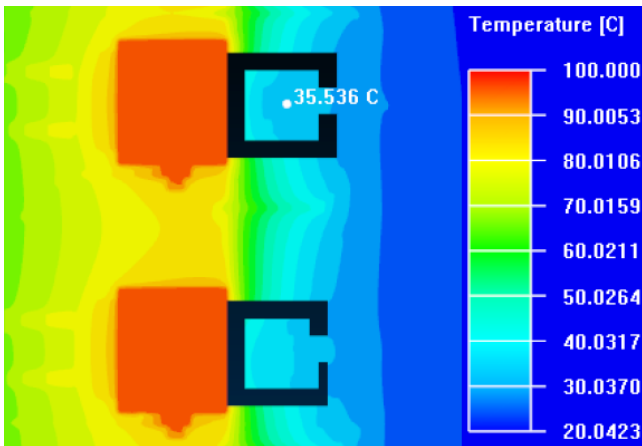

Figure 4. Thermal air gap with a 1.8-mm slot width.

When designing the PCB for the temperature sensor, it is important to follow good layout techniques. **Figure 5** shows a PCB layout with an isolation island and contour routing, while **Figure 6** shows an alternative design that incorporates perforations around the section with the temperature sensor.

On both mini-boards, the dimensions are small enough to allocate only the sensor and bypass capacitor—the smaller the thermal mass of the island, the better the thermal response. These designs greatly minimize the amount of heat transfer from other components.

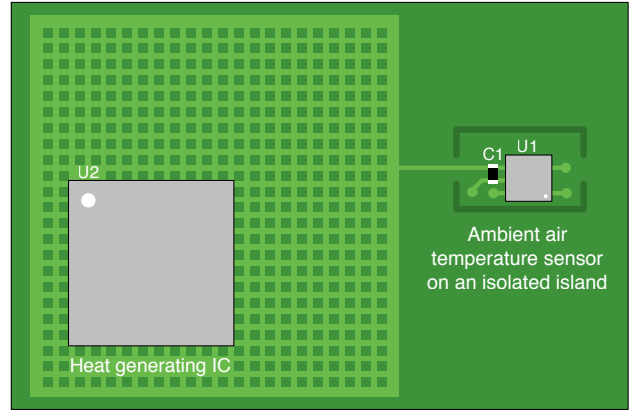

Figure 5. Isolation island PCB layout.

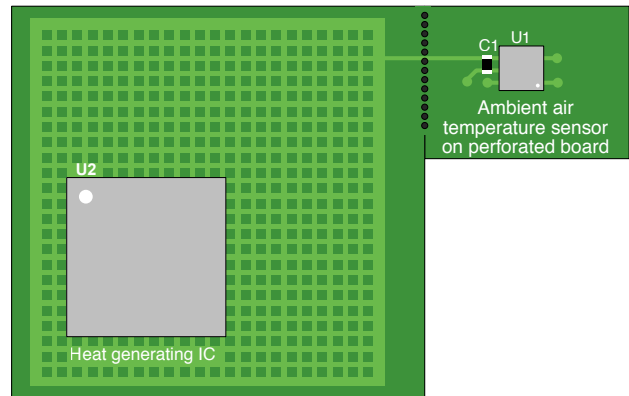

Figure 6. Perforated PCB layout.

Differential temperature

In applications requiring more precise measurement, consider a differential temperature design. This type of design adds additional sensors next to hot components (as shown in **Figure 1**) and measures the difference in temperature between sensors A and B.

A model of how the ΔT correlates to ambient temperature is required, however, and will vary depending on the system application. A differential design factors in the impact of self-heating to provide a more accurate algorithm to estimate the ambient temperature.

Device recommendations

The TMP112 and TMP116 are digital temperature sensors designed for high-accuracy, low-power applications such as environmental monitoring and thermostat controls. The TMP112 offers an accuracy of $\pm 0.5^\circ\text{C}$ from 0°C to 65°C , whereas the TMP116 offers an accuracy of $\pm 0.2^\circ\text{C}$ from -10°C to 85°C .

Both temperature sensors are highly linear, require zero calibration and have programmable alert functionality. The TMP112 features a compact 1.60-mm-by-1.20-mm small outline transistor (SOT)-563 package, while the TMP116 features a 2-mm-by-2-mm very very thin small outline no-lead (WSON) package.

To ensure optimal performance and device longevity, **Table 2** lists collateral with additional layout recommendations.

Resource	Title
Application report	Design considerations for measuring ambient air temperature
Application report	Precise temperature measurement with TMP116

Table 2: Related TI content.

Section 3.2

Efficient cold-chain management with scalable temperature sensors

Introduction

To maintain nutrients and ensure quality and product safety, manufacturers specify transportation and storage temperatures for packaged and perishable items, especially food and medicines. But before reaching consumers at their local grocery, fruits, vegetables and frozen meals spend a significant time in transportation and on the shelves of large refrigeration units, as shown in **Figure 1**. It is crucial to maintain these items at the correct temperature.



Figure 1. Typical grocery aisle.

Cold-chain management ensures the right conditions during every phase of the life cycle of packaged and perishable items. Cold-chain management also ensures that operators can take appropriate action either during transportation or storage if a possible excursion outside the storage temperature is about to occur.

Cold-chain topology

Temperature sensors with gauges have been popular for a long time. However, with advances in semiconductor technology—and the fact that most cold-chain management happens in the -40°C to +10°C temperature range—integrated temperature sensors are the best option for cold-chain management.

Different topologies are possible given the application. As shown in **Figure 2**, in a point-to-point topology, a single microcontroller (MCU) connects to a temperature sensor that may be an analog or digital output sensor. A point-to-point topology is useful while managing a pallet of goods during shipping.

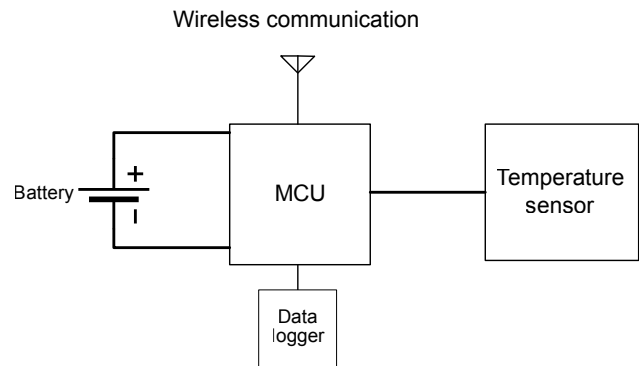

Figure 2. Point-to-point topology.

When sensing a set of cold unit containers like refrigerators, the cost of a single MCU is too high to be implemented multiple times in the entire system. In such cases, the most common topologies are the star, shared bus or daisy chain (**Figure 3**):

- A star topology enables easy fault isolation if one of the branches fails. Star topologies may use both analog and digital output temperature sensors, but have a higher implementation cost because the controller peripheral count is higher and the system cannot scale very well.
- In a shared-bus topology, one MCU acts as the host controller for multiple sensors. Scalability is easily

addressable with digital temperature sensors. A shared-bus topology shares the line, but can still be individually addressed using in-band addressing like an I²C bus or out-of-band signaling using chip select, which is the case with the Serial Peripheral Interface. Reliable power delivery and signal integrity over a long chain may be a concern with I²C, however.

- The daisy chain does not require out-of-band signaling and uses an in-band addressing scheme. With each stage of the chain acting as a buffer for the next chain, the signal integrity over longer distances improves.

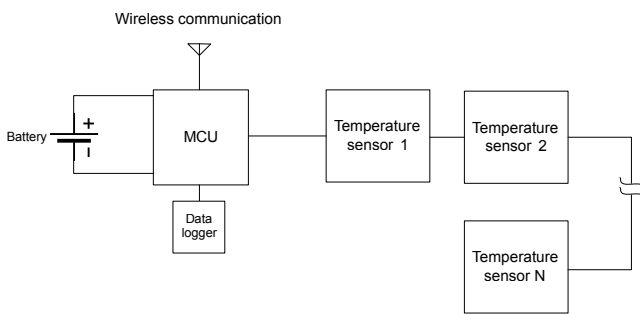

Figure 3. A daisy chain of temperature sensors.

Irrespective of the cold-chain management monitoring stage, electronic systems have a unique advantage because they cannot only log the temperature of a pallet

or refrigeration unit, but also provide thresholds that generate alerts above a certain threshold. Such events can be visually communicated through audio or visual alerts like a buzzer or flashing LED, but also integrated into cloud services using wired or wireless MCUs, enabling round-the-clock monitoring and data logging.

Device recommendation

The TMP107 digital output temperature sensor supports a total of 32 daisy-chained devices and can replace NTC thermistors in cold-chain management applications that require both high accuracy and system-wide scalability. The TMP107 has a maximum accuracy specification of $\pm 0.4^{\circ}\text{C}$ in the range of -20°C to $+70^{\circ}\text{C}$ and $\pm 0.55^{\circ}\text{C}$ in the range of -40°C to $+100^{\circ}\text{C}$, with a temperature resolution of 0.015625°C .

With an automated address assignment, the TMP107 allows system developers to write software without assigning the address at each sensor node, as the system scales by adding additional sensor nodes. At the same time, with the use of a push-pull communication input/output, the system is made more resilient against noise that affects temperature values over long cables. Such resilience enables data transfers over span lengths of 1,000 feet between adjacent devices in the chain.

Figure 4 shows the signal integrity of a communication interface at 9,600 bps. The SMAART wire™ digital interface uses a Universal Asynchronous Receiver

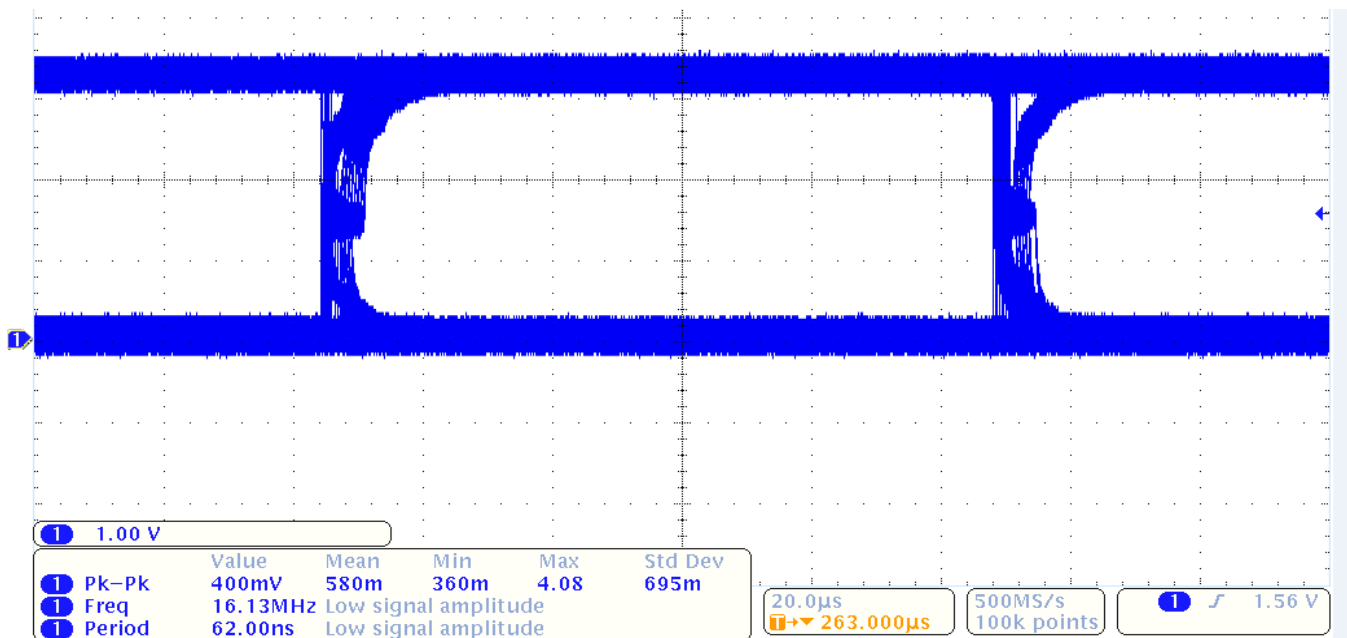

Figure 4. Eye diagram for the TMP107.

Transmitter bus, which is a standard peripheral on almost all MCUs, making it easier to develop software. At the same time, a daisy-chain implementation makes it easier to identify the location of a cable break, which enables easy maintenance and overall system reliability.

The current consumption of the TMP107 when performing temperature conversions with active bus communication is typically 300 μ A. It has a shutdown current of 3.8 μ A in low-power mode. With a wide operating voltage of 1.7 V to 5.5 V, its low current consumption makes it a good fit for battery-operated systems during the transport phase of cold-chain management. Increasing the baud rate enables real-time updates, helpful when storing frozen food.

Additionally, the TMP107 stores the configuration and temperature limits in internal nonvolatile memory. This enables the device to be autoconfigured on power up, eliminating the need for individual device configurations and making the system operate faster. It also has eight electrically erasable programmable read-only memory (EEPROM) locations, providing up to 128 bits of EEPROM to store user information or calibration information.

The daisy-chain topology is the best way to implement efficient cold-chain temperature monitoring. The TMP107 has the right combination of accuracy, power consumption and features to support a battery-based cold-chain management system.

Table 1 presents an alternative device recommendation for this implementation.

Device	Optimized parameters	Performance trade-off
TMP144	Small form factor	16 devices in daisy chain and 1°C accuracy

Table 1: Alternative device recommendation.

For more information about this topic, or for general tips on cold-chain market, see the related content in **Table 2**.

Resource	Title
Blog post	How sensor technology is evolving to meet cold chain needs
Application note	Temperature sensing cold chain asset tracking

Table 2: Related TI content.

Chapter 4: Body temperature monitoring

Understanding a patient's temperature is a critical first step in any clinical diagnosis, and an important concern for athletes as well. Beyond the need for ultra-high accuracy, industry trends are moving toward compact wearable form factors to provide continuous temperature monitoring. Temperature sensors with up to 0.1°C accuracy not only meet American Society for Testing and Materials E1112 requirements for medical thermometers, but are also optimized to keep battery-powered wearables compact and comfortable.

Design challenges of wearable temperature sensing

Introduction

Monitoring patient vital signs in a clinical environment has traditionally been a job for expensive and heavily calibrated systems, requiring the tethering of patients to bedside monitors. Wireless patient monitoring systems provide both patient comfort and clinical convenience, as long as they can still conform to strict medical standards.

Wearable temperature monitors have many design trade-offs between power consumption, size, system performance (in terms of both radio frequency [RF] and accuracy), and patient comfort. For example, thinner, flexible batteries provide greater comfort but may require more careful power management.

Smaller, lower-cost designs suffer in terms of thermal isolation and RF performance. Solutions for long-term monitoring must make good use of board area to improve accuracy and signal integrity, while keeping current consumption as low as possible. System designers must balance these requirements alongside the comfort and experience of the patient.

Standard compliance for thermometers

American Society for Testing and Materials (ASTM) E1112 and International Organization for Standardization (ISO) 80601-2-56:2017 are the governing standards for intermittent electrical patient thermometers. For standards-compliant clinical temperature measurement applications under ASTM E1112, human body temperature monitors must produce readings within $\pm 0.1^\circ\text{C}$ accuracy, and must read and display

temperatures from a minimum of 35.8°C to 41.0°C. At minimum, any temperature monitoring design should include a sensing element able to meet these requirements after calibration.

TI recommends the TMP117 ultra-high-accuracy digital temperature sensor for wearable temperature monitors. The device itself has better than 0.1°C accuracy from 25°C to 50°C and requires no calibration to meet the requirements of both ASTM E1112 and ISO 80601-2-56:2017. Additionally, the TMP117's low overall current draw and one-shot mode are a good fit for battery-operated applications. The digital I²C output of the TMP117 also greatly simplifies system design when compared with resistance temperature detector (RTD)- or thermistor-based solutions.

Layout considerations

Even with an appropriate sensing element, ensuring total system accuracy will still require careful board layout. To monitor skin temperature, the best layout will:

- Maximize thermal isolation between the sensing element and other devices.
- Minimize the thermal mass surrounding the temperature sensing element for faster response.
- Provide good thermal contact between the patient and the sensing element to minimize the temperature gradient between the sensor and the target.

Optimizing thermal isolation and thermal mass

Figure 1 shows an example skin temperature monitoring system. The TMP117 digital temperature sensor is extended from the rest of the printed circuit board (PCB) by using a narrow arm to minimize thermal conductance from the rest of the board.

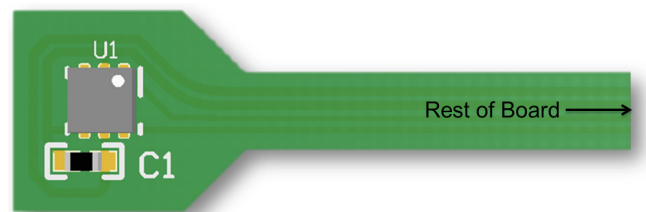

Figure 1. The TMP117 (U1) on a flexible PCB. Using an extended arm isolates the integrated circuit from heat generated by other devices.

Figure 2 shows the stackup for the same two-layer flexible PCB. Using a flex board helps reduce the total thermal mass, which improves the thermal response time of the patient monitor. Omitting copper fills between the top and bottom side of the board avoids drawing heat away from the TMP117 and increasing the thermal mass.

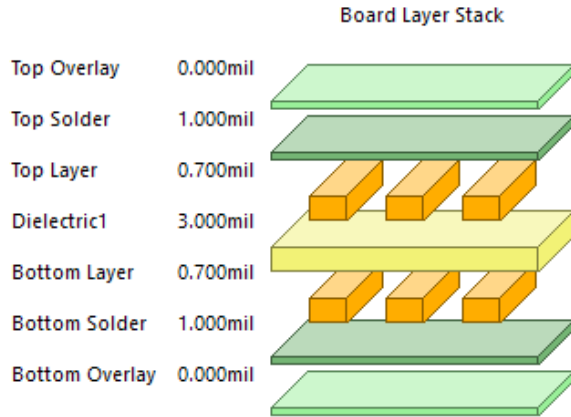

Figure 2. Example flex layer stack, minimizing thickness to reduce thermal mass.

Thermal contact

Reliable measurement of a patient’s skin temperature requires good thermal contact between the patient being monitored and the sensing device. This thermal contact works in conjunction with the thermal isolation from the rest of the board to ensure that the temperature being reported is as close as possible to the patient’s actual skin temperature. With the TMP117, a solid copper pour and contact vias can provide a thermal path from the underside of the board, as shown in **Figure 3**. The pad contacts the wearer’s skin directly, and ensures that the primary heat source for the device is from the person being monitored.

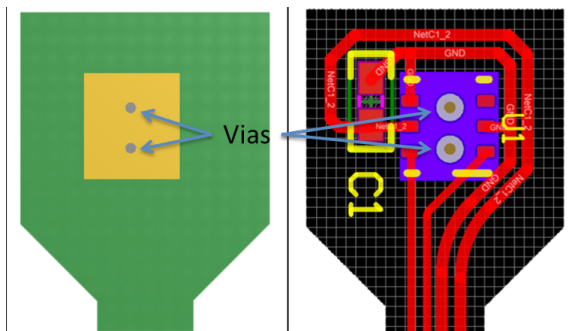

Figure 3. Copper pour underneath the TMP117 (left); top-side layout for the TMP117 (U1, right). The vias underneath the TMP117 and copper pour provide a thermal path between the patient’s skin and the device.

Self-heating

Regardless of the choice of sensing element and layout, the stringent accuracy requirements for medical thermometers require an acknowledgment of the effects of device self-heating. Some self-heating will always be present from the resistive losses of the chosen sensing element. The TMP117 is configurable for one-shot mode conversion and can remain in shutdown mode between successive reads to minimize self-heating. The one-shot feature of the TMP117 can trigger individual temperature readings using a configurable number of averaged readings. Human body temperatures do not conventionally exhibit changes on the order of seconds, so taking these readings at 10- to 60-second intervals is sufficient to monitor patient temperatures over long periods. This method has the added benefit of extending the system’s active battery life.

System power

Power requirements will vary based on overall system design, but most wireless patient monitors will need to have enough energy storage for several years of shelf life, and at least 48 to 72 hours of active life. Coin-cell batteries can easily exceed these requirements for energy capacity, but they are entirely rigid and may be uncomfortable for patients. In disposable patches, a coin-cell based solution can be extremely wasteful.

An alternative option for energy storage is to use thin-film, flexible batteries. Due to their small storage capacities, using these batteries require minimal total system power consumption. For only intermittent temperature monitoring, systems powered with flexible batteries can exceed a given application’s battery requirements for multiple years of shelf life and 48 to 72 hours of active time.

Making system trade-offs

Although following the layout recommendations is essential to comply with ASTM E1112 and ISO 80601-2-56, there are other system design considerations. For patient comfort, it’s best to keep non-temperature-sensing devices and the RF region in as small an area as possible. Keeping the populated region of the board compact will reduce the portion of the monitor that feels rigid to the patient.

For RF communication, any wireless protocol that can work on a flexible PCB is acceptable. Since most

wearable patient monitors will want to keep power consumption low, TI recommends a *Bluetooth*[®] Low Energy wireless communication link. If the information being transmitted from the monitor is only temperature, the monitor can be configured to broadcast the temperature reading alongside its pairing ID. Sending the information in this manner removes the need to make and maintain an actual connection, reducing system power consumption even further.

To get more information on this topic, or for general tips when measuring temperature, please see the related TI content in **Table 1**.

Resource	Title
Reference design	Bluetooth-enabled high accuracy skin temperature measurement flex PCB patch reference design
Application report	Wearable temperature-sensing layout considerations optimized for thermal response
Application note	Layout considerations for wearable temperature sensing

Table 1: Related TI content.

Chapter 5: Fluid temperature monitoring

For many metering and industrial processes, it's necessary to have either a direct measure of a fluid's temperature, or use temperature data for compensation purposes in order to more accurately calculate the volumetric rate of flow. Fluid temperature monitoring applications require that the sensors not only be small—to reduce resistance in the flow—but also low power, in cases where the fluid is flammable. TI's low-power analog and digital solutions have an accuracy comparable to Class-AA resistance temperature detectors that draw as little as 6.3 μ W.

RTD replacement in heat meters using digital temperature sensors

Introduction

A heat meter is a device that measures thermal energy by measuring the flow rate and change of temperature between the inlet and outlet pipes of a system. These devices are common in industrial plants to measure boiler outputs, and in residential heating and cooling systems to measure heat delivery.

Since the measurement of thermal energy requires both flow rate and temperature, it is imperative to measure both parameters accurately. An inaccurate measurement can cause an incorrect energy delivery measurement, leading to either underbilling or overbilling.

A passive component called a resistance temperature detector (RTD), whose resistance changes with temperature, avoids measurement errors. RTDs are made using metals such as platinum, copper or nickel, and support a wide temperature range (approximately -200°C to +850°C).

As shown in **Table 1**, the accuracy of an RTD is defined by its class. The International Electrotechnical Commission (IEC)/European Norms (EN) 60751 defines four RTD classes—C, B, A and AA—where Class-C is the least accurate and Class-AA is the most accurate. Lower-accuracy classes will have a larger temperature range. For example, a Class-C thin-film RTD covers the temperature range of -50°C to +600°C, while a Class-AA thin-film RTD covers a temperature range from 0°C to +150°C.

Applying a current source generates a voltage differential across the RTD; this voltage is proportional to the resistance of the RTD and its excitation current. This voltage data is used to measure the delta between the two temperature sources' from the inlet and outlet pipes.

Fluid temperature measurement in heat meters

Solid-state heat meters are becoming more popular for calculating the billing of heat energy for residential and industrial users. These meters come with both flow measurement on either the inlet or outlet pipe and a pair of matched RTD probes on both inlet and outlet pipes.

Figure 1 shows a block diagram of a heat meter system using RTDs.

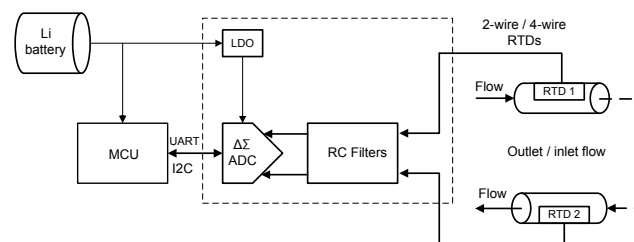

Figure 1. Fluid temperature measurement with RTDs.

Tolerance class	Temperature range of validity		Tolerance values (°C)	Resistance at 0°C (Ω)	Error at 100°C (°C)
	Wire-wound	Thin-film			
AA	-50°C to +250°C	0°C to +150°C	$\pm(0.1 + 0.0017^*t)$	100 \pm 0.04	0.27°C
A	-100°C to +450°C	-30°C to +300°C	$\pm(0.15 + 0.002^*t)$	100 \pm 0.06	0.35°C
B	-196°C to +600°C	-50°C to +500°C	$\pm(0.3 + 0.005^*t)$	100 \pm 0.12	0.8°C
C	-196°C to +600°C	-50°C to +600°C	$\pm(0.6 + 0.01^*t)$	100 \pm 0.24	1.6°C

Table 1: Temperature accuracy classes per IEC 60751.

RTDs provide both low power and high accuracy—desirable features, since in most residential units heat meters are stand-alone battery-powered systems. The system’s ability to quickly wake from power-off mode, sample the RTD temperature and return to power-off mode extends battery life and minimizes energy consumption.

However, these systems require that well-matched RTDs read the differential measurement correctly. At the same time, system cost and complexity require careful design considerations.

Typical thermal energy meters use a pair of PT100, PT500 or PT1000 sensors connected to a high-precision analog front end. Specifications such as EN 1434 in Europe define the requirements for these meters. Two key aspects of this specification are:

- **Sensor accuracy and type.** Chapter 5.4 in EN 60751 recommends industrial platinum resistance thermometers with an accuracy higher than Class-B or equal to Class-A or Class-AA in a three- or four-wire configuration. EN 1434-2 states that you can use other types of temperature sensors, but if you do, they cannot be separated from the heat meter or heat calculator device.
- **Calibration.** Chapter 4.1 of EN 1434-2 states that all temperature pairs must be pre-calibrated and paired before they are built into the heat meter. Alternatively, the sensors should be firmly mounted onto the heat meter’s printed circuit board and calibrated afterwards to minimize the temperature offset between the two PT sensors.

Design considerations with digital temperature sensors for heat meters

High-accuracy digital temperature sensors integrate a sensor and an analog-to-digital converter into a single device. No additional processing is required for temperature conversion by the host microcontroller.

Let’s assess the design considerations based on the industry-standard specifications listed above:

- **Sensor accuracy and type.** Digital temperature sensors like the TMP117 support $\pm 0.1^{\circ}\text{C}$ across -20°C to $+50^{\circ}\text{C}$, with a maximum accuracy specification of $\pm 0.3^{\circ}\text{C}$ across the temperature range

of -55°C to $+150^{\circ}\text{C}$. This exceeds the Class-AA RTD accuracy in the same range, complying with the EN 60751 and EN 1434-2 specification for accuracy and sensor type.

- **Calibration.** A sensor’s ability to reproduce a reading when the measured temperature is applied consecutively under the same conditions is called repeatability. The TMP117 has a repeatability of $7.8125\text{ m}^{\circ}\text{C}$, which leads to very consistent and reliable performance of the sensor itself. The TMP117 also includes a temperature offset register that can be used to store the temperature offset during initial calibration and then added to the temperature result after linearization. Calibration of the sensor pairs at the inlet and outlet is a must-have for heat meter fluid temperature measurements. Having a good repeatability specification and an offset register enables a reliable, repeatable and ultimately simplified design.

Designing with a digital temperature sensor eliminates the offset and gain calibration steps for the analog signal chain, which is required with traditional analog signal measurements in two-, three-, or four-wire RTD-based configurations. The ability to store user-defined calibration parameters in the 8-byte electrically erasable programmable read-only memory (offset register) can even eliminate paperwork and calibration data-handling efforts when compared to traditional analog RTD sensors. It is also more energy-efficient to read out the nonvolatile memory content once at the beginning and apply the offset or any other adjustments to the result each time the temperature is measured

Figure 2 shows a heat-meter architecture using the TMP117 digital temperature sensor.

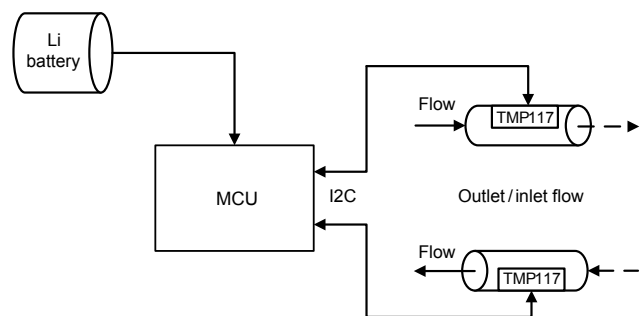

Figure 2. Fluid temperature measurement with the TMP117.

The four-wire digital interface using this architecture is electrically compatible to the standard analog four-wire RTD sensor. An RTD-based design also requires a high-precision reference resistor, typically with accuracy better than 0.1% and ± 25 ppm/ $^{\circ}\text{C}$, and matched resistor-capacitor filters. The need for such high precision reference resistor is also eliminated with the integrated digital design approach.

Table 2 summarizes the design considerations with an RTD sensor and the TMP117 digital temperature sensor.

	RTD	TMP117 digital temperature sensor
Component selection		
Sensor	•	•
Analog-to-digital converter (ADC)	•	
References	•	
Precision bias resistor	•	
Pricing	•	•
Design considerations		
Temperature range	•	•
ADC dynamic range	•	
Programmable gain amplifier gain	•	
Reference current	•	
Filter design	•	
Temperature drift	•	
Self-heating	•	
Power consumption	•	•
Layout		
Trace impedance matching	•	
Thermal pathways	•	•
Noise	•	Only for I ² C lines
Software		
ADC sample rate	•	•
Current digital-to-analog converter chopping	•	
Linearization	•	
Production		
Calibration	•	

Table 2: Design considerations for RTD and digital temperature sensors.

Overall, the high-accuracy TMP117 temperature sensor eliminates the need for multiple narrow-tolerance discrete components and integrated devices, which can save PCB space, complexity and cost in heat meters.

For additional resources for high-accuracy fluid temperature sensing, see **Table 3**.

Resource	Title
Reference design	Replacing platinum RTD sensors with digital temperature sensors reference design
Application report	Precise temperature measurements with TMP116

Table 3: Related TI content.

Chapter 6: Threshold detection

For some applications, continuous temperature collection is unnecessary, but it's critical for the system to stay above or below a temperature threshold. TI temperature switches and digital temperature sensors enable simple autonomous temperature monitoring to detect with hysteresis when the temperature crosses its limits. These devices enable the selection of threshold trip points through an external resistor, that is either pin-programmable, factory-programmed or over I²C.

How to protect control systems from thermal damage

Introduction

In control systems, operating temperature is one of many key factors that can affect a system's performance, reliability and safety. Understanding the effects of temperature on control systems can help system designers anticipate and prevent thermal damage.

Typically, the behavior of control systems is well understood, and they operate within a limited temperature range. When operating outside that temperature range, the control system may experience decreased efficiency, increased heat dissipation and accelerated aging. The combination of these effects may lead to costly failures.

Thermal protection solutions

A number of preventive solutions are available to protect control systems from thermal damage. These solutions can either be discrete or integrated, and typically consist of a temperature sensor, a comparator and a voltage reference (see **Figure 1**).

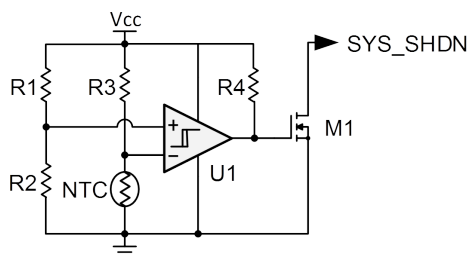

Figure 1. Example discrete implementation of a temperature switch.

An external temperature switch circuit provides real-time thermal protection without interrupting the control processing system. **Figure 2** shows example temperature switch-trip behavior where the trip point is set to 60°C with 10°C hysteresis.

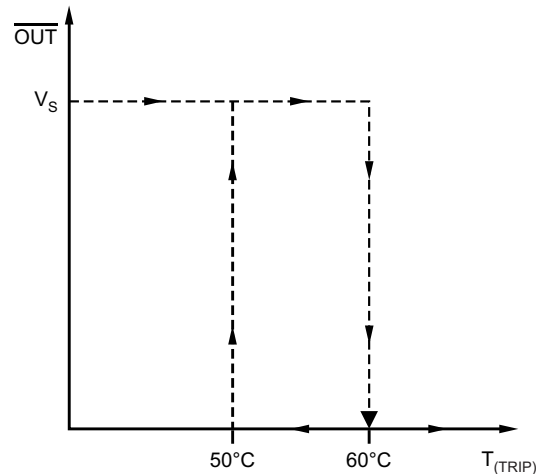

Figure 2. Example temperature switch-trip behavior with hysteresis.

Some cases require both thermal protection and monitoring functions and thus require an analog-to-digital converter (see **Figure 3**). The specific implementation depends on application requirements such as features, cost, footprint, power and accuracy.

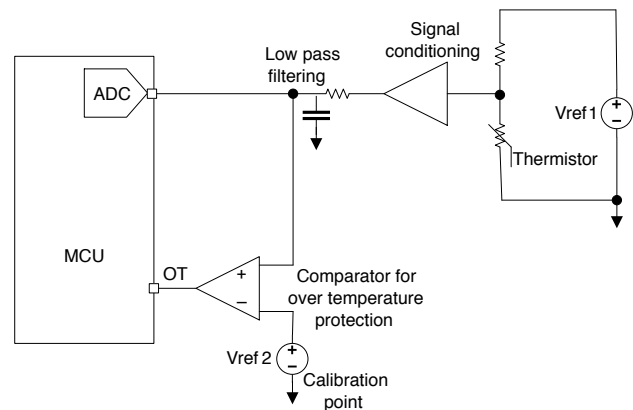

Figure 3. Example discrete implementation of a temperature monitor and switch.

Some of the features to consider include hysteresis, accuracy, trip-point programmability, trip test, qualifications (like automotive and Underwriters

Laboratories [UL]), output type, channel count and supply-voltage range.

Both hysteresis and accuracy help improve overall control system reliability. Sensors typically have a measurement error represented in degrees Celsius. These measurement errors will need compensating in the form of the most suitable measurement. Reducing such offset error before initiating a shutdown increases system reliability. Not correcting for such errors can result in an overtemperature error.

For example, if the system needs to cut off at a temperature of 60°C, it is best to have accuracy in order to ensure that the system powers down. Hysteresis gives the system time to settle and prevents the control system from frequent power cycles. As in the example in **Figure 2**, 10°C hysteresis would optimize the system's performance within 50°C to 60°C.

With negative temperature coefficient (NTC)-based thermistors, there is need to linearize the thermistor in software to optimize the system error over temperature. Linearization is typically performed through polynomial fitting or a lookup table. Such methods not only increase overall system cost, but also impact the power consumption. Using a linear silicon-based thermistor with a positive temperature coefficient (PTC) can eliminate software and power penalties.

Discrete solutions

It is quite common to see a discrete implementation of a temperature switch using an NTC thermistor. In addition, thermistor solutions are often considered low cost. However, given the demanding requirements of thermal protection (like guaranteed performance), discrete solutions often prove challenging and costly. Some of the key challenges when designing a discrete thermal protection solution are accuracy, reliability and efficiency.

Because NTC thermistors are nonlinear, maintaining a high-accuracy trip point at high or low temperatures is difficult without using precision components that can increase system cost. Calibration is not practical in hardware-based switching applications. In addition, a discrete implementation requires multiple components working together, and can decrease system reliability.

Lastly, NTC discrete solutions dissipate a significant amount of power when hot, because the NTC resistance significantly decreases at high temperatures.

Integrated circuit solutions: temperature switches/thermostats

Integrated temperature switches typically have a temperature sensor, comparator and voltage reference on a single chip. Such integration can reduce design complexity and enable real-time thermal protection without constantly interrupting the control processing system.

Here are the key advantages of these sensors.

- They autonomously enable thermal protection for the control unit without continuous monitoring.
- There's no software dependency; the temperature monitoring firmware for protection is replaced with a simple alert to the control system.
- Hysteresis guarantees temperature accuracy for the trip points.
- Simple and cost-effective over/undertemperature detection replaces the protection circuit.
- It's possible to set the temperature threshold through resistors, or be pin-programmable. In some cases, the temperature switch can be preset at the factory.
- Applications that require an analog output can leverage a temperature switch to provide an analog output in addition to the alert.

An integrated sensor lowers solution costs, enabling redundancy in safety applications.

Device recommendations

The TMP303 integrated temperature switch uses a window comparator and offers design flexibility through an extra-small footprint (small outline transistor [SOT]-563), low power (5- μ A maximum) and low supply-voltage capability (as low as 1.4 V). No additional components are required for operation, and the device can function independently of microprocessors or microcontrollers. Seven trip points are available through different device options, which are programmable at the factory to any desired temperature.

The TMP390, as shown in **Figure 4**, is a resistor-programmable dual-output temperature switch with two internal comparators and two outputs. The TMP390 offers ultra-low power (1- μ A maximum) and low supply-voltage capability (1.62 V). Both the hot and cold trip points can be configured to any desired temperature

window, with hysteresis options between 5°C and 30°C using just two resistors. The separate hot and cold trip outputs generate independent warning signals for interpretation by the microprocessor.

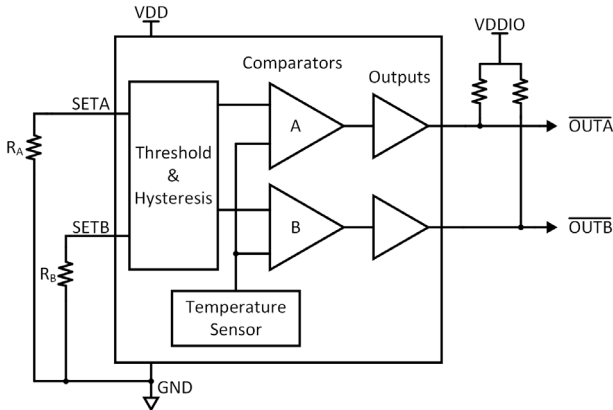

Figure 4. TMP390 block diagram.

Table 1 lists alternative devices for either discrete or integrated temperature threshold detection applications.

Device	Optimized parameters	Performance trade-off
TMP708	Resistor programmable	Reduced accuracy
LM56	Two internal comparators with two overtemperature outputs and one analog output	Increased power consumption
LM26	Overtemperature and analog inputs, UL recognized	Reduced accuracy
TMP61	Low power consumption, linearity over temperature	Additional components required

Table 1: Alternative device recommendations.

For more information about temperature protection, see the additional resources in Table 2.

Resource	Title
Application report	Temperature sensors: PCB guidelines for surface mount devices
Application report	How to protect battery power management systems from thermal damage

Table 2: Related TI content.

Figure 3 depicts the results of an oil bath experiment conducted on the TMP117. The graph shows that the TMP117 can meet the accuracy of a Class-AA RTD for a CJC application.

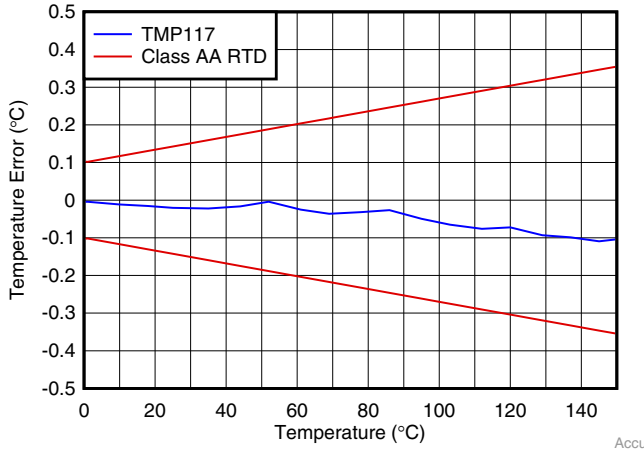

Figure 3. The TI TMP117 vs. RTD accuracy.

The TMP117 features a shutdown mode where the device aborts the currently running conversion and enters a low-power shutdown mode. In this mode, the device typically consumes 250 nA of current, mitigating the effects of self-heating. When triggered by an MCU, the TMP117 can perform quick, 15.5-ms temperature conversions using the one-shot conversion mode, with active current as low as 3.5 μA for a duty cycle of 1 Hz. After completing a one-shot conversion, the device automatically returns to low-power shutdown mode. This simplifies the software implementation versus an RTD, eliminating the need for calibration, external circuitry, matched traces and Kelvin connections.

The TMP117 also features fast-mode (400-kHz) I²C communication and an offset register that automatically applies a user-defined offset to the measurement results before an MCU read. These specifications make the

TMP117 excellent for meeting low-power consumption requirements in CJC applications for field transmitters.

As described earlier, the TMP117 is comparable in accuracy to Class-AA thin-film RTDs and consumes a fraction of the power of a PT100 RTD when used in CJC applications.

Figure 4 is a block diagram for a CJC system, using the TMP117 to replace the RTDs. Systems using the TMP117 eliminate the need for additional components, such as delta-sigma ADCs, programmable gain amplifiers and resistor-capacitor filters, thus reducing overall system cost. At the same time, the device’s digital readout reduces complex layout considerations.

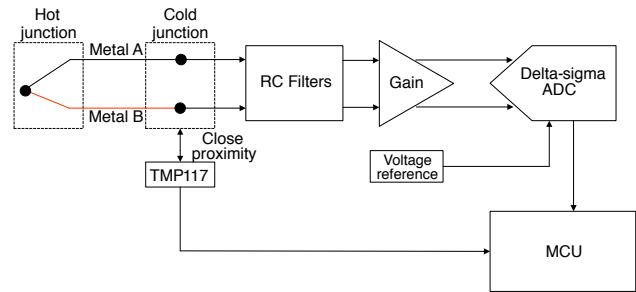

Figure 4. CJC with the TMP117 system block diagram.

For more information on high-accuracy temperature calibration and compensation for field transmitters, see the additional resources in **Table 1**.

Resource	Title
Application report	RTD Class-AA replacement with high-accuracy digital temperature sensors in field transmitters
Application report	Precise temperature measurements with TMP116

Table 1: Related TI content.

Section 7.2

Methods to calibrate temperature monitoring systems

Introduction

Aside from manufacturing process variations, temperature sensors are affected by various environmental effects. These include thermal stress; mechanical stress; radiation; humidity; and aging during storage, shipment and/or assembly that may alter a device’s intrinsic characteristics (such as accuracy or reliability) after its implementation in the final system.

The physical placement of a temperature sensor has a significant impact on a device’s apparent accuracy relative to the target heat source due to the local temperature gradient. There is a distinction between apparent and intrinsic accuracy. It’s possible to improve apparent accuracy with physical design (for example, printed circuit board [PCB] design with improved heat-transfer characteristics), but accuracy is an inherent device characteristic. In addition, external components connected to temperature sensors (for example, an analog-to-digital converter [ADC] and filters) may have a significant impact on overall system performance. Both environmental and system electrical factors may require calibration to achieve traceable accuracy.

Analog temperature sensors such as the TMP236 or negative temperature coefficient (NTC) thermistors require an ADC to translate voltages to temperatures. This additional circuit component affects overall system performance due to error contributions from the ADC.

Figure 1 shows an example thermistor circuit.

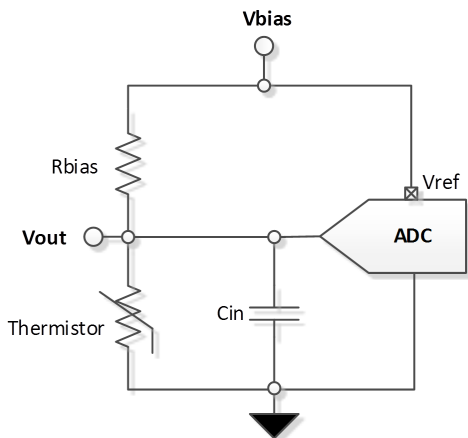

Figure 1. Example temperature-sensing circuit with a thermistor.

Unlike an integrated circuit (IC) temperature sensor, some thermistor applications require a bias resistor, which will introduce an additional source of error. System errors typically manifest themselves as system gain and offset errors, which can be reduced to some extent using calibration.

For nonlinear systems, an additional linearization step may be required depending on the application. **Figure 2** shows the general three-step process. Note that the figure depicts only the average-value lines. The actual sensor output will have a statistical distribution about the average.

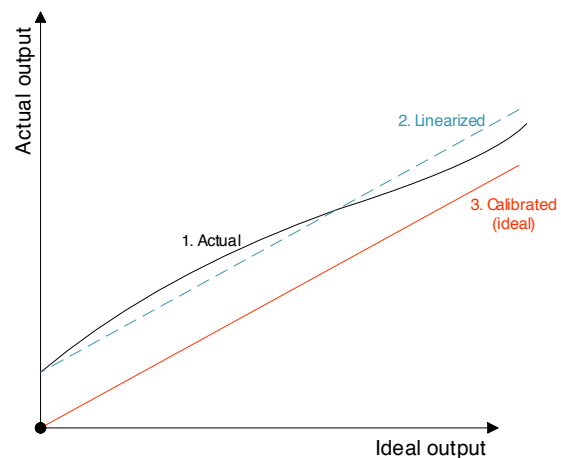

Figure 2. Generalized three steps of temperature sensor calibration.

System calibration for traceability

The system calibration process compares the final assembled measurement system to a known, traceable measurement standard (for example, the National Institute of Standards and Technology, Underwriters Laboratories, European Norms) to establish a quantifiable measurement uncertainty. In the best case, the system response is linear and the system can be easily calibrated with just a simple offset, or gain and offset corrections. However, temperature sensors are not perfectly linear and thus cannot be easily calibrated without linearization. Typically, a nonlinear system response requires multipoint linearization using a lookup table before gain and offset calibration.

Analog temperature monitoring systems

Analog temperature monitoring systems require linearization and calibration to achieve a high level of accuracy and traceability. The degree of linearization

depends on the linearity of the sensor itself. NTC thermistors will generally require more system trade-offs (for example, memory, central processing unit cycles and sensitivity) for linearization compared to analog IC temperature sensors (for example, the TMP236). Analog IC temperature sensors are typically more linear across a wide temperature range compared to NTC thermistors. Regardless, an additional step of calibration is required to achieve a system-level accuracy that is also traceable.

Calibration methods

For production purposes, calibrating a statistically significant number of systems (for example, 30) determines the appropriate correction coefficients for the total number of systems. This statistical approach limits production costs. In some cases, calibration methods performed during the production test stage use a single-point room-temperature calibration. Multipoint calibration at the production test stage can result in better system accuracy, but is more expensive. Thus, multipoint calibration processes are typically applied to specialized systems where the production volume is relatively low. Regardless of calibration method, reference probe accuracy and traceability are essential components of calibration.

Zero calibration sensors

Unlike analog temperature sensors, digital temperature sensors such as the TMP117 do not require any additional system linearization or calibration to achieve traceable system accuracy. As shown in **Figure 3**, a digital sensor is effectively a temperature-monitoring system on a chip. These traceable devices are linearized

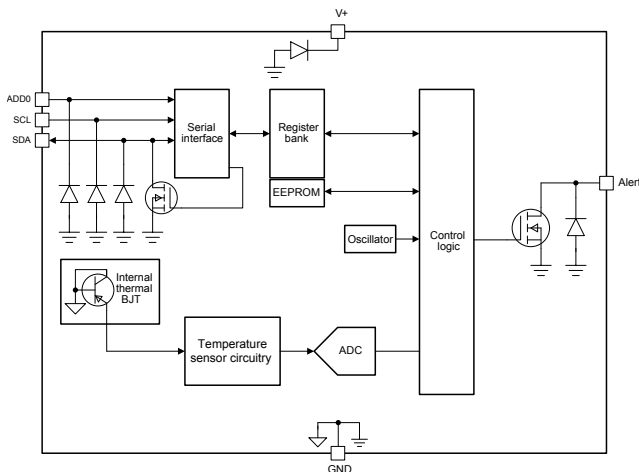

Figure 3. TMP117 functional block diagram.

and calibrated in production, greatly simplifying system implementation. Note that the TMP117 does feature an offset register that enables the calibration of any temperature offset (for example, from physical system temperature gradients).

TI temperature sensors and design tips

Table 1 lists key optimized parameters for some TI temperature sensors, as well as their trade-offs.

Device	Optimized parameters	Performance trade-off
TMP117	Zero calibration and linearization, high accuracy	May have a longer read time compared to analog sensors
TMP236	Linear analog output without an external bias circuit	May require an ADC
TMP390	Zero calibration and linearization, integrated temperature switch	Fewer features than digital sensors
TMP61	2-pin, small package, linear resistance	May require an ADC and bias circuit

Table 1: Device recommendations.

To learn more about printed circuit board guidelines, ambient air measurement or linearization, see **Table 2**.

Resource	Title
Application report	Temperature sensors: PCB guidelines for surface mount devices
Application report	Design considerations for measuring ambient air temperature
Application report	Methods to reduce thermistor linearization error, memory and power requirements over wide operating temperature ranges

Table 2: Related TI content.

Additional resources
TI Precision Labs video training
Reference designs
Analog Wire blog
TI E2E™ Community

Achieve Class-AA RTD accuracy simply

New high accuracy $\pm 0.1^{\circ}\text{C}$ single-chip digital temperature sensor slashes power for industrial applications

Temperature Sensor

TMP117



TI's sensor portfolio enables engineers to dream big and design small with highly accurate, small-size sensors. The portfolio features industry-leading package options and many of the world's most accurate sensors to design reliable systems that intelligently anticipate with precision.

TI Worldwide Technical Support

TI Support

Thank you for your business. Find the answer to your support need or get in touch with our support center at

www.ti.com/support

China:

<http://www.ti.com.cn/guidedsupport/cn/docs/supporthome.tsp>

Japan:

<http://www.tij.co.jp/guidedsupport/jp/docs/supporthome.tsp>

Technical support forums

Search through millions of technical questions and answers at TI's E2E™ Community (engineer-to-engineer) at

e2e.ti.com

China:

<http://www.deyisupport.com/>

Japan:

<http://e2e.ti.com/group/jp/>

TI Training

From technology fundamentals to advanced implementation, we offer on-demand and live training to help bring your next-generation designs to life. Get started now at

training.ti.com

China:

<http://www.ti.com.cn/general/cn/docs/gencontent.tsp?contentId=71968>

Japan:

<https://training.ti.com/jp>

B011617

Important Notice: The products and services of Texas Instruments Incorporated and its subsidiaries described herein are sold subject to TI's standard terms and conditions of sale. Customers are advised to obtain the most current and complete information about TI products and services before placing orders. TI assumes no liability for applications assistance, customer's applications or product designs, software performance, or infringement of patents. The publication of information regarding any other company's products or services does not constitute TI's approval, warranty or endorsement thereof.

The platform bar, E2E, SMAART wire and TINA-TI are trademarks of Texas Instruments. All other trademarks are the property of their respective owners.

IMPORTANT NOTICE AND DISCLAIMER

TI PROVIDES TECHNICAL AND RELIABILITY DATA (INCLUDING DATASHEETS), DESIGN RESOURCES (INCLUDING REFERENCE DESIGNS), APPLICATION OR OTHER DESIGN ADVICE, WEB TOOLS, SAFETY INFORMATION, AND OTHER RESOURCES "AS IS" AND WITH ALL FAULTS, AND DISCLAIMS ALL WARRANTIES, EXPRESS AND IMPLIED, INCLUDING WITHOUT LIMITATION ANY IMPLIED WARRANTIES OF MERCHANTABILITY, FITNESS FOR A PARTICULAR PURPOSE OR NON-INFRINGEMENT OF THIRD PARTY INTELLECTUAL PROPERTY RIGHTS.

These resources are intended for skilled developers designing with TI products. You are solely responsible for (1) selecting the appropriate TI products for your application, (2) designing, validating and testing your application, and (3) ensuring your application meets applicable standards, and any other safety, security, or other requirements. These resources are subject to change without notice. TI grants you permission to use these resources only for development of an application that uses the TI products described in the resource. Other reproduction and display of these resources is prohibited. No license is granted to any other TI intellectual property right or to any third party intellectual property right. TI disclaims responsibility for, and you will fully indemnify TI and its representatives against, any claims, damages, costs, losses, and liabilities arising out of your use of these resources.

TI's products are provided subject to TI's Terms of Sale (www.ti.com/legal/termsofsale.html) or other applicable terms available either on ti.com or provided in conjunction with such TI products. TI's provision of these resources does not expand or otherwise alter TI's applicable warranties or warranty disclaimers for TI products.

Mailing Address: Texas Instruments, Post Office Box 655303, Dallas, Texas 75265
Copyright © 2019, Texas Instruments Incorporated