

QL Series

**Precision Power
Supplies**

Service Manual



Table of Contents

Specification	2
EMC	5
Safety	6
General	7
Circuit Descriptions	8
Calibration	11
Parts List	13
Block Diagram	31
Interconnection Diagram	32
Component Layouts	33
Circuit Diagrams	38

Specification

General specifications apply for the temperature range 5°C to 40°C. Accuracy specifications apply for the temperature range 18°C to 28°C after 1 hour warm-up with no load and calibration at 23°C. Typical specifications are determined by design and are not guaranteed.

MAIN OUTPUTS

Voltage/Current Ranges:	QL355	QL564				
	0V to 35V/0.001A to 3A 0V to 35V/0.1mA to 500mA 0V to 15V/0.001A to 5A	0V to 56V/0.001A to 2A 0V to 56V/0.1mA to 500mA 0V to 25V/0.001A to 4A				
Voltage Setting:	Resolution 1mV Accuracy $\pm (0.03\% + 5mV)$					
Current Setting:	Resolution 1mA; 0.1mA on 500mA range Accuracy $\pm (0.2\% + 5mA)$; $\pm (0.2\% + 0.5mA)$ on 500mA range.					
Output Mode:	Constant voltage or constant current with automatic cross-over. CI indicator lit in constant current mode.					
Output Switch:	Electronic, non isolating. Switch illuminated when Output on. Preset voltage and current limit displayed when Output off.					
Output Terminals:	4mm terminals on 19mm (0.75") spacing for Output; screwless terminals for Sense. Duplicate rear panel Output and Sense screw terminals on remote control model (QL355P/TP & QL564P).					
Transient Response:	<50 μ s to within 15mV of set level for a change in load current from full load to half load or vice versa.					
Voltage Programming Speed:	Maximum time required for output to settle within 1% of its total excursion (for resistive load). Excludes command processing time.					
	QL355	QL564				
	<i>Full Load</i>	<i>No Load</i>				
	<i>Full Load</i>	<i>No Load</i>				
Up	15V 5A	6ms	6ms	25V/4A	10ms	6ms
Up	35V 3A	20ms	7ms	56V/2A	40ms	15ms
Up	35V 500mA	200ms	40ms	56V/500mA	300ms	60ms
Down	15V 5A	6ms	250ms	25V/4A	10ms	400ms
Down	35V 3A	25ms	600ms	56V/2A	50ms	800ms
Down	35V 500mA	120ms	600ms	56V/500mA	200ms	800ms
Ripple and Noise (20MHz bandwidth):	Normal mode voltage: <0.35mVrms and 2mVp-p Normal mode current: <0.2mArms; <20 μ Arms on 500mA range.					
Load Regulation:	For any load change, measured at the output terminals, using remote sense. Voltage <0.01% + 2mV. Current <0.01% + 250 μ A; <0.01% + 50 μ A on 500mA range. Add typically 2.5mV for a 0.5V drop in the positive output lead. Specification applies for sense lead resistance <0.5 Ω .					
Line Regulation:	Voltage <0.01% + 2mV for 10% line change. Current <0.01% + 250 μ A; <0.01% + 50 μ A on 500mA range.					
Temperature Coefficient:	Voltage: typically <(50ppm + 0.5mV)/°C Current: typically <(100ppm + 1mA)/°C; (100ppm + 0.1mA)/°C on 500mA range.					
Output Protection:	Output will withstand forward voltages of up to 20V above rated output voltage. Reverse protection by diode clamp for currents up to 3A.					

Over-voltage Protection: (OVP)	Range 1V to 40V (QL355), 1V to 62V (QL564) Resolution 0.1V; accuracy $\pm (2\% + 0.5V)$ Response time typically 100 μ s
Over-current Protection: (OCP)	Range 0.01A to 5.5A (QL355), 0.01A to 4.4A (QL564) Resolution 0.01A; accuracy $\pm (0.2\% + 0.01A)$ Response time typically 35ms
Protection Functions:	Output trips off for OVP, OCP, over-temperature and Sense miswiring.

METER SPECIFICATIONS

Display Type:	5-digit (Volts), 4-digit (Amps), 14mm (0.56") LED.
Voltage (CI mode):	Resolution 10mV Accuracy $\pm (0.1\% \text{ of reading} + 10\text{mV})$
Current (CV mode):	Resolution 0.001A; 0.1mA on 500mA range Accuracy $\pm (0.2\% + 0.005A)$; $\pm (0.2\% + 0.5\text{mA})$ on 500mA range
V x A:	Resolution 0.01W; 0.001W on 500mA range Accuracy $\pm (0.3\% + 0.05W)$; $\pm (0.3\% + 0.005W)$ on 500mA range

AUXILIARY OUTPUT (QL355T/TP)

Voltage:	2.7V, 3.3V or 5V, selectable by front panel switch.
Voltage Accuracy:	$\pm 5\%$
Current Limit:	1A minimum
Output Protection:	Output will withstand up to 16V forward voltage. Diode clamp reverse protection for currents up to 3A.
Output Terminals:	4mm terminals on 19mm (0.75") spacing. Duplicate screwless terminals on rear panel.
Ripple & Noise: (20MHz bandwidth)	Typically <1mV rms
Load & Line Regulation:	<1.0% for a 90% load change; 0.1% for a 10% line change.
Status Indication:	Current limit lamp.

ALARM OUTPUT

Isolated rear-panel open-collector output signal. User can select output to be activated for either OVP, OCP, Overtemperature or Sense miswiring, or for any of those four faults.

KEYBOARD & ROTARY CONTROL

All functions, including the selection and set-up of the remote control interfaces, can be set from the keyboard. The rotary jog control can be used to adjust output voltage and current settings in a quasi-analogue mode.

INTERFACES (QL355P/TP & QL564P only)

Full remote control facilities are available through the optional RS232, GPIB and USB interfaces. Setting and readback resolutions are the same as for the Output and Meter specifications respectively.

RS232:	Variable Baud rate, 19200 Baud maximum. 9-pin D-connector. Single instrument or Addressable RS232 Chain (ARC) operation.
IEEE-488:	Conforming with IEEE488.1 and IEEE488.2
USB:	Standard USB hardware connection.
Remote Command Processing Time:	Typically <80ms between receiving the command terminator for a step voltage change at the instrument and the output voltage beginning to change.

GENERAL

AC Input:	230V AC or 115V AC \pm 10%, 50/60Hz. Installation Category II
Power Consumption:	Single: 250VA max. Triple: 500VA max.
Operating Range:	+5°C to +40°C, 20% to 80% RH
Storage Range:	-40°C to + 70°C
Environmental:	Indoor use at altitudes up to 2000m, Pollution Degree 2.
Cooling:	Intelligent variable-speed fan. Over-temperature trip shuts down output if internal temperatures exceed predetermined thresholds.
Store/Recall:	Up to 10 set-ups can be saved and recalled via the keyboard or remote interfaces.
Safety:	Complies with EN61010-1
EMC:	Complies with EN61326
Size:	Single: 140 x 160 x 290mm (WxHxD), excluding feet and terminals. Triple: 280 x 160 x 290mm (WxHxD), excluding feet and terminals.
Weight:	Single: 5.5kg Triple: 10.5kg

This instrument has been designed to meet the requirements of the EMC Directive 89/336/EEC. Compliance was demonstrated by meeting the test limits of the following standards:

Emissions

EN61326 (1998) EMC product standard for Electrical Equipment for Measurement, Control and Laboratory Use. Test limits used were:

- a) Radiated: Class B
- b) Conducted: Class B
- c) Harmonics: EN61000-3-2 (2000) Class A; the instrument is Class A by product category.

Immunity

EN61326 (1998) EMC product standard for Electrical Equipment for Measurement, Control and Laboratory Use.

Test methods, limits and performance achieved were:

- a) EN61000-4-2 (1995) Electrostatic Discharge : 4kV air, 4kV contact, Performance A.
- b) EN61000-4-3 (1997) Electromagnetic Field, 3V/m, 80% AM at 1kHz, Performance A.
- c) EN61000-4-11 (1994) Voltage Interrupt, 1 cycle, 100%, Performance B.
- d) EN61000-4-4 (1995) Fast Transient, 1kV peak (AC line), 0.5kV peak (DC Outputs), Performance B.
- e) EN61000-4-5 (1995) Surge, 0.5kV (line to line), 1kV (line to ground), Performance B.
- f) EN61000-4-6 (1996) Conducted RF, 3V, 80% AM at 1kHz (AC line only; DC Output connections <3m not tested), Performance A.

According to EN61326 the definitions of performance criteria are:

Performance criterion A: 'During test normal performance within the specification limits.'

Performance criterion B: 'During test, temporary degradation, or loss of function or performance which is self-recovering'.

Performance criterion C: 'During test, temporary degradation, or loss of function or performance which requires operator intervention or system reset occurs.'

Where Performance B is stated it is because DC Output regulation may deviate beyond Specification limits under the test conditions. However, the possible deviations are still small and unlikely to be a problem in practice.

Note that if operation in a high RF field is unavoidable it is good practice to connect the PSU to the target system using screened leads which have been passed (together) through an absorbing ferrite sleeve fitted close to the PSU terminals.

Cautions

To ensure continued compliance with the EMC directive observe the following precautions:

- a) after opening the case for any reason ensure that all signal and ground connections are remade correctly and that case screws are correctly refitted and tightened.
- b) In the event of part replacement becoming necessary, only use components of an identical type, see the Service Manual.

Safety

This power supply is a Safety Class I instrument according to IEC classification and has been designed to meet the requirements of EN61010-1 (Safety Requirements for Electrical Equipment for Measurement, Control and Laboratory Use). It is an Installation Category II instrument intended for operation from a normal single phase supply.

This instrument has been tested in accordance with EN61010-1 and has been supplied in a safe condition. This instruction manual contains some information and warnings which have to be followed by the user to ensure safe operation and to retain the instrument in a safe condition.

This instrument has been designed for indoor use in a Pollution Degree 2 environment in the temperature range 5°C to 40°C, 20% - 80% RH (non-condensing). It may occasionally be subjected to temperatures between +5°C and -10°C without degradation of its safety. Do not operate while condensation is present.

Use of this instrument in a manner not specified by these instructions may impair the safety protection provided. Do not operate the instrument outside its rated supply voltages or environmental range.

WARNING! THIS INSTRUMENT MUST BE EARTHED

Any interruption of the mains earth conductor inside or outside the instrument will make the instrument dangerous. Intentional interruption is prohibited. The protective action must not be negated by the use of an extension cord without a protective conductor.

When the instrument is connected to its supply, terminals may be live and opening the covers or removal of parts (except those to which access can be gained by hand) is likely to expose live parts. The apparatus shall be disconnected from all voltage sources before it is opened for any adjustment, replacement, maintenance or repair.

Capacitors inside the power supply may still be charged even if the power supply has been disconnected from all voltage sources but will be safely discharged about 10 minutes after switching off power.





Any adjustment, maintenance and repair of the opened instrument under voltage shall be avoided as far as possible and, if inevitable, shall be carried out only by a skilled person who is aware of the hazard involved.

If the instrument is clearly defective, has been subject to mechanical damage, excessive moisture or chemical corrosion the safety protection may be impaired and the apparatus should be withdrawn from use and returned for checking and repair.

Make sure that only fuses with the required rated current and of the specified type are used for replacement. The use of makeshift fuses and the short-circuiting of fuse holders is prohibited.

Do not wet the instrument when cleaning it.

The following symbols are used on the instrument and in this manual:-

	Earth (ground) terminal.
	mains supply OFF.
	mains supply ON.
	alternating current (ac)
	direct current (dc)

Service Handling Precautions

Service work or calibration should only be carried out by skilled engineers using high quality test equipment. If the user is in any doubt as to his competence to carry out the work, the instrument should be returned to the manufacturer or their agent overseas for the work to be carried out.

Please note the following points before commencing work.

The tracks on the printed circuit boards are very fine and may lift if subjected to excessive heat. Most of the integrated circuits are static sensitive and great care should be taken when handling them to avoid damage due to static discharge. Also, most devices on the Control board are surface mounted components with very fine leads on small pitches. These components must be removed and replaced with great care to avoid damage to the PCB. It is essential that only the proper tools and soldering equipment as recommended for surface mount components are used.

Dismantling the instrument

WARNING!

Disconnect the instrument from all voltage sources before it is opened for adjustment or repair. If any adjustment or repair of the opened instrument is inevitable it shall be carried out only by a skilled person who is aware of the hazards involved.

1. Remove the six screws retaining the top cover and lift clear.
2. To remove the pcbs, first improve access by unscrewing the front panel: remove the screw(s) securing the front panel bracket(s) to the spacer in the centre of the Power pcb(s) and remove the screws that fix the bottom edge of the front panel to the chassis. The front panel can be tipped forward to give access to the latching connectors connecting the Keyboard to the Power pcb; disconnect these, noting orientation.
3. To remove the Power and Control pcbs remove the two screws securing the Power pcb to the central fan bracket and the two screws fixing the Power pcb bracket to the rear panel. Unplug the two transformer connectors, the fan connector and any inter-pcb connections (Power to Power on a triple output supply, and/or Power to Interface on programmable versions) noting their positions carefully; a diagram is provided at the end of this manual showing how these connections are made. The Control pcb is plugged into the Power pcb and both can now be lifted clear together.
4. The Display/Keyboard pcb can be removed from the front moulding after pulling off the jog wheel and removing the fixing screws, two of which also secure the front panel bracket (four on the triple).
5. To remove the Interface pcb from the rear panel, undo the jackscrews of the GPIB and RS232 sockets and the self-tap screw in the chassis which retains the inner support bracket.
6. When re-assembling the instrument ensure that all fixings use the correct fasteners. Replace cut cable ties. Do not over tighten the display/keyboard fixing screws in the moulding. Check that the fan operates.

Circuit Descriptions

The Power board contains the main power supply and the auxiliary supplies used internally, the output series regulator transistors, the microcontroller, display drivers and some control logic.

The Control board contains voltage and current control, ADC and DAC and some control logic.

The linear regulator is in series with the positive output but, because of the way in which the control circuit is referenced to the +ve output, it is convenient to consider the regulated output as the negative side.

To help reading the circuit diagrams the two connectors between the power and control pcbs join as follows. PJ14 to PJ18 and PJ20 to PJ19.

Power Pcb

The main windings are connected either in series (for the high voltage range) or in parallel (for the low voltage range) by the range relays and an electronic tap change at approximately half range is used to reduce dissipation. Bridge rectifier BR1 feeds C4 the reservoir capacitor when tap change is low. When tap change is high, two of the diodes in BR1 are bypassed by SCR1 and SCR2. Voltages are listed below at nominal mains (230V).

QL355	35V/3A	15V/5A
Secondary – high tap, no-load	39.8VAC	19.9VAC
Secondary – high tap, full-load	37VAC	18.9VAC
C4 – high tap, no-load	51.5VDC	24.5VDC
C4 – high tap, full-load	44.7VDC	21.9VDC

QL564	56V/2A	25V/4A
Secondary – high tap, no-load	60VAC	30.1VAC
Secondary – high tap, full-load	56VAC	28.6VAC
C4 – high tap, no-load	79.5VDC	38.4VDC
C4 – high tap, full-load	69.5VDC	35.2VDC

A 30Vrms centre tapped winding and full wave rectification provide the auxiliary supplies. IC1 generates +10V and IC2 –5V. A 10.4Vrms winding and full wave rectification power the relays and fan and IC3 provides the +5V for the microcontroller, display and control logic.

Comparator IC6A provides the system reset signal and comparator IC6B provides the power fail signal to the microcontroller to store the instrument settings at power down.

The fan speed is regulated by a pulse width modulator in the microcontroller; if the heatsink exceeds a certain temperature measured by Q22, comparator IC50A switches the fan to full speed. If the heatsink temperature continues to rise IC50B will pull the over-temperature line low which will turn the output off.

Q15 and Q16 are the series regulator transistors; long-tailed pair Q17 and Q21 ensure current sharing. The +10V supply to emitter follower Q14 is via switch Q13 which is turned on after a delay to prevent output glitches when power is turned on.

Microcontroller IC39, which is factory programmed, writes the calibration values and instrument settings to non-volatile memory IC31, reads the keyboard, spin-wheel and status of the instrument via shift registers (4021s), reads the ADC, outputs data via shift registers (4094s) and display drivers IC32, IC33 and IC38, and writes to the DAC.

Jumpers are fitted to SEL1 to 7 to inform the microcontroller of the model type and to LK1 and LK2 to power the opto-couplers, see table below.

	SEL1	SEL2	SEL3	SEL4	SEL5	SEL6	SEL7	LK1	LK2
QL355				Yes					
QL355P				Yes					
QL355T output 1								Yes	Yes
QL355T output 2			Yes						
QL355TP output 1									
QL355TP output 2			Yes						
QL564						Yes			
QL564P						Yes			

The transformer windings are in series for the high voltage range and in parallel for the low voltage range. D4, R14,C16 and D7,R15,C17 ensure the correct switching sequence of the range relays.

IC8C and IC8D form an oscillator to drive the buzzer.

TP2 carries a synchronising pulse output which makes it possible to view the DAC sample and hold outputs and the ADC input selector signals.

TP3 provides an output that toggles at each stage of the range change switching sequence.

Control Pcb

IC2 is a 16-bit DAC and the reference to it is supplied via IC19B which allows fine adjustment for voltage and current settings. The DAC output is multiplexed into 7 sample and holds. IC14A is for the voltage control (VC); when the output is off IC42B grounds its input via VR2. IC28B drives the guard track (GV) round the VC sample and hold. An identical circuit is used for the current control (IC). IC20B is the voltage control error amplifier and IC21A is a differential amplifier. With the output at 35.0V VM will be -1.74V and VC will be 1.47V. Comparator IC26B is for over voltage protection (OVP). A relay selects local or remote voltage sensing; if the voltage between an output and its sense reaches $2xV_{be}$ either Q19 or Q20 will turn on turning the output off.

IC20A is the current control error amplifier and IC22 is a differential amplifier with a gain of 10. R50 is used for the high current range and R51 is used for the 500mA range selected by IC23. Q3 shorts out R51 when the high current range is selected. If the current limit is set to 2.0A IC will be approximately 846mV. With a 2Amp load on the high range IM will be -1V. Over current protection (OCP) is realised in software. When the power supply is in constant current mode IC20A has control and comparator IC17B drives the CI line high.

IC37 is a 12-bit ADC; ADREF is adjusted for voltage and current measurements and is approximately 4V. IC27B has a gain of -2; therefore if, for example, VM was -2V then the output of IC27B would be +4V. Offsets are trimmed by ADOFST. To achieve 13-bit resolution two measurements are taken with and without the 13th bit subtracted from the input selected by IC24C.

Any trip condition is latched by IC29 and IC30 and cleared by the microcontroller by pressing escape. IC18 is used for synchronising the switching of the outputs on triple units.

Auxiliary Output

Each transformer has a 4Vrms winding and these are connected in series at the Auxiliary Power pcb. IC3 is an adjustable low drop out regulator. The 3 preset output voltages are achieved by changing the value of R7, by switching resistors in parallel with it. The regulator is turned on by pulling pin 2 low. IC3 has internal current limiting and when the limit is reached the output voltage will start to fall; this is detected by comparator IC5, by comparing against the 2.5V reference IC4, turning on Q1 which turns on the I-limit led and the opto to signal current limit, which is used only by the remote interface.

Interface Pcb

The GPIB board is controlled by the Z80 based processor in IC6, which has associated EPROM IC7 and RAM IC8. IC6 contains two UARTs. UART 0 generates and receives data lines CTRL TX and CTRL RX which are used to control the power supply hardware. These signals are sent and received over an RS485 type bus which communicates with the PIC processor(s) residing on the control board(s). This bus is opto-isolated on the control boards. The internal control bus driver consists of IC3-D and Q1. The receiver consists of IC3-F and IC3-E.

The second UART in IC6 is used to send/receive over the external RS232 and USB buses. UART 1 I/O signals, COMMS RX and COMMS TX, are selected in IC16-A and IC16-B. When RS232 is selected as the power supply's communication bus (USB SEL low), these gates switch COMMS RX and COMMS TX to RS232RX and RS232TX. The RS232 interface conforms to the proprietary ARC standard. The drivers and receivers for the RS232 interface consist of IC1 and IC2. When USB is selected as the communication bus COMMS RX and COMMS TX are connected to USB RX and USB TX. USB RX is generated by IC17 and USB TX is routed to IC17.

IC17 translates USB signals to RS232 type signals. It therefore only works when the USB interface is driven by special USB drivers in the communicating controller (e.g. PC) which encode RS232 signals onto the USB. IC17 is accompanied by IC15 which is an EEPROM programmed with product specific data. The controller reads this data when the power supply is connected to the controller's USB port. The data is used in the automatic 'enumeration' process within the controller.

IC16-C, R9 and Q2 are used to switch R15 onto the USB data + line. When R15 is connected to +3.3V, generated by IC17, it identifies the device to the controller as a full speed USB device. It is disconnected from +3.3V if USB is not selected as the power supply's communication interface (USB SEL low) or if there is no voltage present on the USB power line, VBUS.

IC9, IC10 and IC11 form the GPIB interface. IC9 is a GPIB controller IC and performs all the GPIB hardware handshaking and status reporting. IC10 and IC11 are GPIB specific buffers. The processor ignores the GPIB interface if GPIB is not selected as the power supply's communication interface. Conversely it ignores COMMS RX and COMMS TX signals if GPIB is selected as the communication interface.

Servicing Note

If IC31 the memory IC located on the power pcb is replaced it is very likely the check sums do not match resulting in "error 999" being displayed. Pressing OK will get out of this condition and initialise the EEPROM. This will only work on a single power supply or on output 2 on a triple power supply. If IC31 has to be replaced on output 1 side of a triple power supply, output 1 and output 2 power boards will have to be interchanged, also links will have to be changed (see table under Power Pcb description) so that the power supply can initialise.

Calibration

Refer to the General section for dismantling instructions and safety precautions. Normal calibration is done without opening the instrument.

Allow 10 minute warm-up before commencing calibration.

Refer to the User Manual for detailed operation of these power supplies.

Equipment Required

A 5.5 digit multimeter with better than 0.02% accuracy on dc volts and better than 0.12% accuracy on dc current (to 5A); alternatively use a precision shunt for current measurement.

Calibration

To enter calibration press **shift #**, 99. If the instrument is a long way out of calibration or has been repaired, the default calibration values should be loaded first by pressing **shift #**, 91. Pressing Escape at anytime will abort the calibration procedure and revert to the stored calibration values.

Having entered calibration mode, follow the table below. To increment to the next step press OK. The calibration **must** be done in sequence. At the end of calibration press OK to store the calibration. The instrument automatically sets the range and settings at each step.

Use the spin-wheel to adjust calibration; holding down the **Jog Off** key will give x100 increments to speed up calibration. Pressing **shift** will show the calibration value.

On triple units (QL355T and QL355TP) calibrate both output 1 and output 2.

There are two internal adjustments which are factory set and will normally only require adjustment if a component has been changed in the associated area. If this is so proceed as follows. VR1 and VR2 are both located near the top of the control pcb. They are accessible from both sides of the board. Turn them both fully clockwise as viewed from the component side, fully anti-clockwise as viewed from the solderside. Adjustment is done with the output set to off. Connect an ammeter across the output terminals and adjust VR1 for +1mA. Remove ammeter and connect voltmeter and adjust for VR2 -10mV. (minus or negative 10mV).

QL355

Step/Range	Settings	Adjust for:-	Load	Detail
1, 35V 3A	0.01V 3A	10mV \pm 0.5mV	DVM	o/p 0V
2, 35V 3A	0.01V 3A	0.010V on display	DVM	V readback zero
3, 35V 3A	35V 3A	35V \pm 0.5mV	DVM	o/p V span
4, 35V 3A	35V 3A	35.000 on display	DVM	V readback span
5, 35V 3A	0.01V 3A	10mV \pm 0.5mV	DVM	o/p 0V
6, 35V 3A	35V 3A	35V \pm 0.5mV	DVM	o/p V span
7, 35V 3A	2V 0.001A	1mA \pm 0.5mA	milli-ammeter	o/p A offset
8, 35V 3A	2V 0.001A	0.001 on display	milli-ammeter	A readback zero
9, 35V 500mA	2V 0.1mA	0.1mA \pm 0.05mA	milli-ammeter	o/p mA offset
10, 35V 500mA	2V 0.1mA	flashing 0.0/0.1 on display	milli-ammeter	mA readback zero
			change load	
11, 15V 5A	2V 4A	4A \pm 0.5mA	ammeter	o/p A span
12, 15V 5A	2V 4A	4.000 on display	ammeter	A readback span
13, 15V 5A	2V 4.1A	4.100 on display	ammeter	A readback 13bit
14, 35V 500mA	2V 400mA	400mA \pm 0.05mA	ammeter	o/p mA span
15, 35V 500mA	2V 400mA	400.0 on display	ammeter	mA readback span
16, 35V 500mA	2V 410mA	410.0 on display	ammeter	mA readback 13bit

QL564

Step/Range	Settings	Adjust for:-	Load	Detail
1, 56V 2A	0.01V 2A	10mV \pm 0.5mV	DVM	o/p 0V
2, 56V 2A	0.01V 2A	0.010V on display	DVM	V readback zero
3, 56V 2A	35V 2A	35V \pm 0.5mV	DVM	o/p V span
4, 56V 2A	35V 2A	35.000 on display	DVM	V readback span
5, 56V 2A	41V 2A	41.000 on display	DVM	V readback 13bit
6, 56V 2A	0.01V 2A	10mV \pm 0.5mV	DVM	o/p 0V
7, 56V 2A	35V 2A	35V \pm 0.5mV	DVM	o/p V span
8, 56V 2A	2V 0.001A	1mA \pm 0.5mA	milli-ammeter	o/p A offset
9, 56V 2A	2V 0.001A	0.001 on display	milli-ammeter	A readback zero
10, 56V 500mA	2V 0.1mA	0.1mA \pm 0.05mA	milli-ammeter	o/p mA offset
11, 56V 500mA	2V 0.1mA	flashing 0.0/0.1 on display	milli-ammeter	mA readback zero
			change load	
12, 25V 4A	2V 4A	4A \pm 0.5mA	ammeter	o/p A span
13, 25V 4A	2V 4A	4.000 on display	ammeter	A readback span
14, 56V 500mA	2V 400mA	400mA \pm 0.05mA	ammeter	o/p mA span
15, 56V 500mA	2V 400mA	400.0 on display	ammeter	mA readback span
16, 56V 500mA	2V 410mA	410.0 on display	ammeter	mA readback 13bit

Parts List

PCB ASSEMBLY – POWER – QL355 (44117-0010)

Part Number	Description	Position
20073-9801	SCREW No.4x1/4in. Plastite	HEATSINK FIXING
20613-0026	SIL-PAD 900S 100MM X 25MM	FOR SK1,2
20661-0290	SPACER Clr No.4 X 22.2mm Nylon	POWER PCB TO COVER
20670-0360	HEATSINK MAXS515 100MM PLAIN	SK1, 2
20670-0364	CLIP MAX01H FOR TO220+MAX H/S	FOR IC1-3, Q22, SCR1, 2
20670-0365	CLIP MAX03H FOR TO247+MAX H/S	FOR BR1,Q15,Q16
22240-0150	RELAY 12V DPDT 8A	RL1, 2
22312-0242	FUSE CLIPS PCB MTG	FOR FS1
22315-0248	FUSE 10A ANTISURGE (T) HBC CER	FS1
22315-0452	FUSE 1.0AT SUBMIN PCB MTG	FS4-6
22573-0041	HEADER 2WAY STR SIL	TP1, LK1, LK2
22573-0048	HEADER 3WAY STR SIL	TP2, 3, 4
22573-0150	HEADER 20 WAY STR LATCHING	PJ10,11
22573-0225	HEADER 5 WAY STR F/LOCK .156	PJ1
22573-0226	HEADER 6 WAY STR F/LOCK .156	PJ2
22573-0247	HEADER 2 WAY STR .1P F/LOCK	PJ7, PJ9
22573-0251	HEADER 6 WAY STR .1P F/LOCK	PJ5,6
22573-0262	HEADER 2 WAY RT ANG F/LOCK .1P	PJ4
22575-0038	HEADER 6WAY STR SIL STD	PJ3
22575-0068	HEADER 14 WAY (2X7) STR	SEL1-7
22575-0103	HEADER 16 WAY (2X8) STR	PJ14, 20
23202-0100	RES 10R0F W60 MF 50PPM	R93
23202-0330	RES 33R0F W60 MF 50PPM	R133
23202-1100	RES 100RF W60 MF 50PPM	R12, 23, 24
23202-1180	RES 180RF W60 MF 50PPM	R1, 2
23202-1220	RES 220RF W60 MF 50PPM	R28
23202-1270	RES 270RF W60 MF 50PPM	R110,127,142
23202-1330	RES 330RF W60 MF 50PPM	R144
23202-1360	RES 360RF W60 MF 50PPM	R60,134
23202-2100	RES 1K00F W60 MF 50PPM	R4,111,130
23202-2120	RES 1K20F W60 MF 50PPM	R20
23202-2150	RES 1K50F W60 MF 50PPM	R29
23202-2220	RES 2K20F W60 MF 50PPM	R109
23202-2470	RES 4K70F W60 MF 50PPM	R16,17,18,112,121

PCB ASSEMBLY – POWER – QL355 (44117-0010) continued/...

Part Number	Description	Position
23202-2510	RES 5K10F W60 MF 50PPM	R21, 22,132
23202-2560	RES 5K60F W60 MF 50PPM	R52
23202-3100	RES 10K0F W60 MF 50PPM	R5, 7-9,13,19, 30,117,120,126,141
23202-3100	RES 10K0F W60 MF 50PPM	R3, 96
23202-3200	RES 20K0F W60 MF 50PPM	R6, 98, 99
23202-3220	RES 22K0F W60 MF 50PPM	R116
23202-3330	RES 33K0F W60 MF 50PPM	R25, 75, 92,129,140
23202-4100	RES 100KF W60 MF 50PPM	R11, 43
23202-4220	RES 220KF W60 MF 50PPM	R14,15,143
23202-5100	RES 1M00F W60 MF 50PPM	R10, 31,115,135
23215-3100	RES 10K0B W25 MF 15PPM	R136,137
23274-0104	RES 0R22J 3W WW	R26, 27
23301-0443	RES NETWK SIL 22K X 8	RP1, 2, 4
23301-0464	RES NETWK SIL 56R X 4S	RP5-8
23301-0468	RES NETWK SIL 22K X 5	RP3
23424-0443	CAP 10NZ 1KV CER D10 P5	C12,13
23428-0100	CAP 10PG 100V CER NPO P2.5T	C56, 57
23557-0500	CAP 1U0 50V ELEC P1.5	C86, 88
23557-0647	CAP 10U 35V ELEC P2	C6-8, 43
23557-0660	CAP 2200U 16V ELEC P5	C3
23557-0664	CAP 1000U 35V ELEC P5	C1, 2
23557-0672	CAP 470U 10V ELEC P3.5	C71
23557-0673	CAP 22U 35V ELEC P2	C14
23557-0770	CAP 10000U 63V ELEC P10	C4,5
23620-0246	CAP 100NK 63V P/E P5	C15,18-20, 55, 61, 64, 67-70, 95, 96
23620-0247	CAP 220NK 63V P/E P5	C16,17
23620-0257	CAP 2U2K 100V P/E P22.5	C9,10
23620-0263	CAP 220NK 250V P/E P15	C11, 23
23620-9007	CAP 10NK 100V P/E P5	C87
25021-0901	DIO 1N4148 B/R	D1-7, 24
25115-0907	DIO 1N4002 B/R	D20, 21
25210-0060	THYRISTOR 2N6507 TO-220	SCR1, 2
25211-0303	RECTIFIER BRIDGE 8A 200V SIL	BR1
25211-9302	RECTIFIER BRIDGE W02G	BR2, 3
25336-5590	TRAN PNP BC559C	Q5-9, 26
25341-0218	TRAN PNP 2N3906	Q13,14

PCB ASSEMBLY – POWER – QL355 (44117-0010) continued/...

Part Number	Description	Position
25377-5490	TRAN NPN BC549C	Q1, 2, 10-12,18, 24
25381-0404	TRAN NPN 2N3904	Q17,21
25383-0505	TRAN NPN BC338	Q23
25386-9300	TRAN NPN TIP31A	Q22
25601-0590	TRAN MOSFET N CHAN HUF75639G3	Q15,16
27001-0020	OPTO-COUPLER CNY17-3	IC44, 52
27001-0050	OPTO-COUPLER 6N136	IC48, 49
27001-0110	OPTO-COUPLED TRIAC 3011	IC4, 5
27103-0003	IC LM393	IC6, 50
27160-0009	IC V/REG 7805	IC3
27160-0014	IC V/REG 7905	IC2
27160-0200	IC V/REG LM317	IC1
27164-0507	IC ULN-2003A	IC38
27226-0210	IC 4021B	IC34, 35, 41
27226-0940	IC 4094B	IC28
27231-0000	IC 74HC00	IC8
27231-0140	IC 74HC14	IC7
27231-5740	IC 74HC574	IC32, 33
27250-1970	IC MCU PIC16F76	IC39
27401-0060	IC 24LC04BP (512x8) EEPROM	IC31
28151-0010	BUZZER	BUZZ1
28500-1160	XTAL – 9.8304MHz – MICRPROCSR	XTL1
35555-3290	PCB – POWER	

PCB ASSEMBLY – POWER – QL564 (44117-0100)

Part Number	Description	Position
20073-9801	SCREW No.4x1/4in. Plastite	HEATSINK FIXING
20613-0026	SIL-PAD 900S 100MM X 25MM	FOR SK1, 2
20661-0290	SPACER Clr No.4 X 22.2mm Nylon	POWER PCB TO COVER
20670-0360	HEATSINK MAXS515 100MM PLAIN	SK1, 2
20670-0364	CLIP MAX01H FOR TO220+MAX H/S	FOR IC1-3, Q22, SCR1, 2
20670-0365	CLIP MAX03H FOR TO247+MAX H/S	FOR BR1, Q15, Q16
22240-0150	RELAY 12V DPDT 8A	RL1, 2
22312-0242	FUSE CLIPS PCB MTG	FS1
22315-0248	FUSE 10A ANTISURGE (T) HBC CER	FS1
22315-0452	FUSE 1.0AT SUBMIN PCB MTG	FS4-6
22573-0041	HEADER2WAY STR SIL	TP1, LK1, LK2

PCB ASSEMBLY – POWER – QL564 (44117-0100) continued/...

Part Number	Description	Position
22573-0048	HEADER3WAY STR SIL	TP2,3,4
22573-0150	HEADER 20 WAY STR LATCHING	PJ10,11
22573-0225	HEADER 5 WAY STR F/LOCK .156	PJ1
22573-0226	HEADER 6 WAY STR F/LOCK .156	PJ2
22573-0247	HEADER 2 WAY STR .1P F/LOCK	PJ7
22573-0251	HEADER 6 WAY STR .1P F/LOCK	PJ5, 6
22573-0262	HEADER 2 WAY RT ANG F/LOCK .1P	PJ4
22575-0038	HEADER 6 WAY STR SIL	PJ3
22575-0068	HEADER 14 WAY (2X7) STR	SEL1-7
22575-0103	HEADER 16 WAY (2X8) STR	PJ14, 20
23202-0100	RES 10R0F W60 MF 50PPM	R93
23202-0330	RES 33R0F W60 MF 50PPM	R133
23202-1100	RES 100RF W60 MF 50PPM	R12, 23, 24
23202-1180	RES 180RF W60 MF 50PPM	R1, 2
23202-1220	RES 220RF W60 MF 50PPM	R28
23202-1270	RES 270RF W60 MF 50PPM	R110,127,142
23202-1330	RES 330RF W60 MF 50PPM	R144
23202-1360	RES 360RF W60 MF 50PPM	R60,134
23202-2100	RES 1K00F W60 MF 50PPM	R4,111,130
23202-2120	RES 1K20F W60 MF 50PPM	R20
23202-2150	RES 1K50F W60 MF 50PPM	R29
23202-2220	RES 2K20F W60 MF 50PPM	R109
23202-2470	RES 4K70F W60 MF 50PPM	R16,17,18,112,121
23202-2510	RES 5K10F W60 MF 50PPM	R21, 22,132
23202-2560	RES 5K60F W60 MF 50PPM	R52
23202-3100	RES 10K0F W60 MF 50PPM	R5, 7-9,13,19, 30,117,120,126,141
23202-3200	RES 20K0F W60 MF 50PPM	R6,98, 99
23202-3220	RES 22K0F W60 MF 50PPM	R3, 96,116
23202-3330	RES 33K0F W60 MF 50PPM	R25, 75, 92,129,140
23202-4100	RES 100KF W60 MF 50PPM	R11,43
23202-4220	RES 220KF W60 MF 50PPM	R14,15,143
23202-5100	RES 1M00F W60 MF 50PPM	R10, 31,115,135
23215-3100	RES 10K0B W25 MF 15PPM	R136,137
23274-0105	RES 0R33J 3W WW	R26, 27
23301-0443	RES NETWK SIL 22K X 8	RP1, 2, 4
23301-0464	RES NETWK SIL 56R X 4S	RP5-8

PCB ASSEMBLY – POWER – QL564 (44117-0100) continued/...

Part Number	Description	Position
23301-0468	RES NETWK SIL 22K X 5	RP3
23424-0443	CAP10NZ 1KV CER D10 P5	C12,13
23428-0100	CAP10PG 100V CER NPO P2.5T	C56, 57
23557-0500	CAP 1U0 50V ELEC P1.5	C86, 88
23557-0647	CAP 10U 35V ELEC P2	C6-8, 43
23557-0660	CAP 2200U 16V ELEC P5	C3
23557-0664	CAP 1000U 35V ELEC P5	C1,2
23557-0672	CAP 470U 10V ELEC P3.5	C71
23557-0673	CAP 22U 35V ELEC P2	C14
23557-0775	CAP 4700U 100V ELEC P10	C4,5
23620-0246	CAP 100NK 63V P/E P5	C15,18-20, 55, 61, 64, 67-70, 95,96
23620-0247	CAP 220NK 63V P/E P5	C16,17
23620-0257	CAP 2U2K 100V P/E P22.5	C9,10
23620-0263	CAP 220NK 250V P/E P15	C11, 23
23620-9007	CAP 10NK 100V P/E P5	C87
25021-0901	DIO 1N4148 B/R	D1-7, 24
25115-0907	DIO 1N4002 B/R	D20, 21
25210-0060	THYRISTOR 2N6507	SCR1, 2
25211-0303	RECTIFIER BRIDGE 8A 200V SIL	BR1
25211-9302	RECTIFIER BRIDGE W02G	BR2, 3
25336-5590	TRAN PNP BC559C	Q5-9, 26
25341-0218	TRAN PNP 2N3906 T	Q13,14
25377-5490	TRAN NPN BC549C	Q1, 2,10-12,18, 24
25381-0404	TRAN NPN 2N3904 T	Q17,21
25383-0505	TRAN NPN BC338	Q23
25386-9300	TRAN NPN TIP31A	Q22
25601-0710	TRAN MOSFET N CHAN STW60NE10	Q15,16
27001-0020	OPTO-COUPLER CNY17-3	IC44, 52
27001-0050	OPTO-COUPLER 6N136	IC48, 49
27001-0110	OPTO-COUPLED TRIAC 3011	IC4,5
27103-0003	IC LM393	IC6, 50
27160-0009	IC V/REG 7805	IC3
27160-0014	IC V/REG 7905	IC2
27160-0200	IC V/REG LM317	IC1
27164-0507	IC ULN-2003A	IC38
27226-0210	IC 4021B	IC34, 35, 41

PCB ASSEMBLY – POWER – QL564 (44117-0100) continued/...

Part Number	Description	Position
27226-0940	IC 4094B	IC28
27231-0000	IC 74HC00	IC8
27231-0140	IC 74HC14	IC7
27231-5740	IC 74HC574	IC32, 33
27250-1970	IC MCU PIC16F76	IC39
27401-0060	IC 24LC04BP (512x8) SER EEPROM	IC31
28151-0010	BUZZER	BUZZ1
28500-1160	XTAL - 9.8304MHZ - MICROPROCSR	XTL1
35555-3290	PCB - POWER	

PCB ASSEMBLY – CONTROL (44117-0020)

Part Number	Description	Position
10300-0313	PAD P/E S/AD 12 X 15MM	FOR R50
22240-0070	RELAY TYPE 47 (12VDC)	RL3
22455-0040	TAB 4.8MAX 0.8MM STR PCB MTG	FAS1, 2
22573-0251	HEADER 6 WAY STR .1P F/LOCK	PJ3
22574-0316	SKT 16 WAY (2x8)	PJ18,19
23105-1100	RES SM0805 100RF W1	R109
23105-1330	RES SM0805 330RF W1	R44-49,122
23105-2100	RES SM0805 1K00F W1	R38, 56, 78-81, 95,106,107,114
23105-2470	RES SM0805 4K70F W1	R28,91
23105-3100	RES SM0805 10K0F W1	R29,31,32,43,52,53,72,73,118,123,124,128
23105-3200	RES SM0805 20K0F W1	R67, 68,102,105
23105-3205	RES SM0805 20K5F W1	R35
23105-3470	RES SM0805 47K0F W1	R76
23105-4100	RES SM0805 100KF W1	R97, 98,108
23105-4220	RES SM0805 220KF W1	R77,103,104,113,131
23105-4270	RES SM0805 270KF W1	R66, 69
23105-4330	RES SM0805 330KF W1	R55, 62, 94
23106-2200	RES SM0805 2K00D W1 25PPM	R83, 84
23106-3100	RES SM0805 10K0D W1 25PPM	R99,100,120,121
23106-3110	RES SM0805 11K0D W1 25PPM	R87
23106-3130	RES SM0805 13K0D W1 25PPM	R88
23106-3200	RES SM0805 20K0D W1 25PPM	R39, 82, 85,101
23202-1150	RES 150RF W60 MF 50PPM	R54,125
23215-2845	RES 8K45B W25 MF 15PPM	R63, 74
23215-3110	RES 11K0B W25 MF 15PPM	R57

PCB ASSEMBLY – CONTROL (44117-0020) continued/...

Part Number	Description	Position
23215-3130	RES 13K0B W25 MF 15PPM	R61
23215-4150	RES 150KB W25 MF 15PPM	R64, 65
23284-0110	RES 0R51J 2W5 WW	R51
23286-0040	RES 0R05J 15W WW ALUM HSD	R50
23385-2220	RES PS/H 2K2 CF 6MM	VR1, 2
23427-0388	CAP 220PK 100V CER P2.5	C81
23427-0388	CAP 220PK 100V CER P2.5	C49
23427-9205	CAP 47PJ 100V CER NPO P2.5	C44-48, 62, 72, 74-78
23428-0100	CAP 10PG 100V CER NPO P2.5T	C37
23557-0500	CAP 1U0 50V ELEC P1.5	C42
23557-0647	CAP 10U 35V ELEC P2	C24, 25, 27, 53, 58, 60
23557-0694	CAP 220U 100V ELEC P5	C40,41
23620-0246	CAP 100NK 63V P/E P5	C22, 23, 26, 28, 30, 33, 35, 36, 39, 54, 59, 65, 66, 79, 80, 82
23620-0247	CAP 220NK 63V P/E P5	C63
23620-0249	CAP 330NK 63V P/E P5	C31, 32, 34
23620-0252	CAP 2N2K 63V P/E P5	C50, 56, 61
23620-0286	CAP 470NF 100V P/E P5	C92, 93
23620-9007	CAP 10NK 100V P/E P5	C51, 52, 55, 57, 84
25021-0901	DIO 1N4148 B/R	D9, 10, 15-19
25031-0040	DIO BAX16	D13, 14
25334-0011	TRAN PNP TIP30	Q18
25336-5590	TRAN PNP BC559C	Q9
25341-0218	TRAN PNP 2N3906	Q25
25377-5490	TRAN NPN BC549C	Q4, 5
25383-0610	TRAN NPN ZTX653	Q19, 20
25601-0620	TRAN MOSFET N CHAN LL	Q3
27103-1040	IC SM LM393	IC17, 26
27106-0644	IC SM TL074CD BI-FET OP AMP	IC15
27106-0645	IC SM TO072CD DUAL BIFET OP AMP	IC31, 32
27106-1080	IC SM OP07CS	IC22
27106-1240	IC SM MCP602	IC28
27106-1250	IC SM MCP602 OP AMP	IC28
27153-1120	IC SM MCP3201B 12 BIT ADC	IC37
27161-0061	IC V/REF AD680 T092	IC16
27162-1030	IC SM MAX5441 ACUA 16 BIT DAC	IC1

PCB ASSEMBLY – CONTROL (44117-0020) continued/...

Part Number	Description	Position
27226-0510	IC 4051B 16 PIN	IC13
27227-0210	IC SM 4021	IC36
27227-0510	IC SM 4051	IC25
27227-0750	IC SM 4075	IC18
27227-0940	IC SM 4094	IC11,IC43
27236-0530	IC SM 74HC4053	IC23-24, IC42, IC44
27239-1320	IC SM 74HC132	IC29-30
35555-3300	PCB - CONTROL	

PCB ASSEMBLY - GPIB INTERFACE (44117-0030)

Part Number	Description	Position
10300-0324	PAD P/E S/AD 6 X 3MM	FOR C5-7, 20, 21
20030-0263	WASHER M3 ZPST	FOR IC4
20038-9501	WASHER M3 Spring	FOR IC4
20210-0101	NUT M3 ZPST	FOR IC4
20234-0011	SCREW M3 X 10 PNHDPZ ZPST	FOR IC4 & PJ4
20611-0003	BUSH POLYESTER TO220	FOR IC4
20613-0006	SIL-PAD TO220	FOR IC4
20670-0060	HEATSINK - REDPOINT TV1505	SK1
22315-0450	FUSE 500mAT SUBMIN PCB MNT	
22573-0041	HEADER 2WAY STR SIL	LK1
22573-0232	HEADER 2W RT ANG F/LOCK .156	PJ3
22574-0430	SKT 24W RA IEEE	PJ4
22574-0450	SKT 9W R/A D-TYPE (CLIP IN)	PJ1
22574-0495	SKT - USB TYPE B - PCB MTG	PJ5
22575-0078	SKT 3 WAY IDT .1P	
23105-0100	RES SM0805 10R0F W1	R10-11
23105-1220	RES SM0805 220RF W1	R5
23105-1470	RES SM0805 470RF W1	R16
23105-2100	RES SM0805 1K00F W1	R20
23105-2150	RES SM0805 1K50F W1	R15
23105-2220	RES SM0805 2K20F W1	R1, R22
23105-3100	RES SM0805 10K0F W1	R2-4, R9, R12, R17-19
23105-4100	RES SM0805 100KF W1	R7-8, R13-14, R21
23105-4470	RES SM0805 470KF W1	R6
23461-0020	CAP SM0805 100NZ 50V CER Y5V	C1-3,C8, C11-13, C15-19,C23-26,C29, C31
23461-0060	CAP SM0805 33NK 50V CER X7R	C22
23461-0100	CAP SM0805 22PJ 50V CER COG	C9-10

PCB ASSEMBLY - GPIB INTERFACE (44117-0030) continued/...

Part Number	Description	Position
23557-0657	CAP 100U 10V ELEC RE2 P2	C5-7
23557-0689	CAP 3300U 16V ELEC RE3 P5	C20-21
23595-0010	CAP SM-A 1U0M 16V TANT	C14
25211-9302	RECTIFIER BRIDGE W02G	BR1
25377-1000	TRAN SM NPN BC849C	Q1-2
27160-0440	IC V/REG LM2940CT5	IC4
27161-2020	IC SM ZSM560 SUPPLY VOLTS MON	IC14
27162-0010	IC 7660	IC5
27163-1600	IC 75160	IC11
27163-1610	IC 75161	IC10
27236-0530	IC SM 74HC4053	IC16
27239-0000	IC SM 74HC00	IC12
27239-0140	IC SM 74HC14	IC3
27239-0320	IC SM 74HC32	IC13
27250-0410	IC UPD7210C GPIB CONT	IC9
27250-0510	IC SM FT8U232AM	IC17
27253-0020	IC SM 64180	IC6
27253-0050	IC SM 14C88	IC1
27253-0060	IC SM 14C89	IC2
27400-0100	IC 27C512 64Kx8 EPRM 200ns	IC7
27403-0010	IC SM 93C46 1K(64x16) EEPROM	IC15
27413-0420	IC SM 32Kx8 CMOS RAM 70-120ns	IC8
28502-0020	RESONATOR CERAMIC 12MHz	XTL1
35555-3470	PCB-GPIB/RS232 INTERFACE	

PCB ASSEMBLY – KEYBOARD (44117-0060)

Part Number	Description	Position
20612-0012	WASHER FIBRE 15.88MM OD	FIT BETWEEN REAR OF PCB AND ENC1. ENC1 TO HAVE TAB BENT FLAT.
22224-0020	ENCODER ROT 24 POSITION	ENC1
25061-0300	LED - SM - RED 3.2 X 2.8MM	LED1, LED3-8, LED11, LED15,LED20, LED24
25061-0301	LED - SM - YELLOW 3.2 X 2.8MM	LK17,18,19, 21, 22, 23
25061-1000	DISPLAY SET QL .56 LED 9MM LEG	
35555-3350	PCB - KEYBOARD	
43171-1310	CONN ASSY 20 WAY - 135MM	

PCB ASSEMBLY – TERMINAL (44117-0070)

Part Number	Description	Position
22467-0120	TERMINAL BLOCK 2W - LIGHT GREY	TB1
22575-0081	SKT 6 WAY IDT .1P	W1-6
23424-0443	CAP 10NZ 1KV CER D10 P5	C2
23557-0695	CAP 10U 100V ELEC P2.5	C93
23620-9007	CAP 10NK 100V P/E P5	C1
25061-0200	LED – T1 ROUND (3mm) - RED	LED25
25117-0020	DIO 1N5401	D22
35515-1960	PCB - TERMINAL	

PCB ASSY – IEC INLET – QL355 (44117-0080)

Part Number	Description	Position
23424-0459	CAP 4N7 250V AC CER	C85,C88
23684-0008	CAP 100NM 250VAC X2 P/E P15	C89
35555-3860	PCB - IEC SKT	

PCB ASSY – KEYBOARD – QL355 (44117-0090)

Part Number	Description	Position
20612-0012	WASHER FIBRE 15.88MM OD	
22224-0020	ENCODER ROT 24 POSITION	ENC1
25061-0300	LED - SM - RED 3.2 X 2.8MM	LED1-11, 13-15, 20, 24, 25, 27-30
25061-0301	LED - SM - YELLOW 3.2 X 2.8MM	LED17-19, LED21-23, LED31-33, LED35-37
25061-0302	LED - SM - GREEN 3.2 X 2.8MM	LED34
25061-1000	DISPLAY SET QL .56 LED 9MM LEG	DISP1-6
35555-3520	PCB - KEYBOARD	
43171-1310	CONN ASSY 20 WAY - 135MM	PJ12-15

PCB ASSY - AUX TERM/POWER – QL355 (44117-0110)

Part Number	Description	Position
20613-0007	SIL-PAD TO220 PLAIN	FOR IC3
20670-0135	CLIP GP02 FOR PCB MTG H/SINKS	FOR IC3
20670-0310	HEATSINK PCB MTG 38MM PLAIN	SK1
22218-0215	SWITCH SLIDE 2P3W	SW1
22315-0457	FUSE 3.0AT SUBMIN PCB MTG	F1
22467-0130	TERMINAL BLOCK 2W R/A	TB1
22573-0207	HEADER 7 WAY STRAIGHT .156P	PJ4
22573-0224	HEADER 4 WAY STR F/LOCK .156	PJ2/3
22573-0249	HEADER 4 WAY STR .1P F/LOCK	PJ1
22575-0207	SKT 7W .156 20AWG (Yellow) IDT	

PCB ASSY - AUX TERM/POWER – QL355 (44117-0110) continued/...

Part Number	Description	Position
23202-1240	RES 240RF W60 MF 50PPM	R4, R11
23202-1249	RES 249RF W60 MF 50PPM	R16
23202-1430	RES 430RF W60 MF 50PPM	R15
23202-1470	RES 470RF W60 MF 50PPM	R13-14
23202-1487	RES 487RF W60 MF 50PPM	R1
23202-1649	RES 649RF W60 MF 50PPM	R2
23202-1750	RES 750RF W60 MF 50PPM	R7-10
23202-2180	RES 1K80F W60 MF 50PPM	R5
23202-2270	RES 2K70F W60 MF 50PPM	R6
23202-2560	RES 5K60F W60 MF 50PPM	R12
23202-3220	RES 22K0F W60 MF 50PPM	R3
23424-0443	CAP10NZ 1KV CER D10 P5	C3, C6
23557-0530	CAP 100U 16V ELEC P2.5	C4
23557-0647	CAP 10U 35V ELEC P2	C9
23557-9122	CAP 4700U 16V ELEC P7.5	C1-2
23620-0246	CAP 100NK 63V P/E P5	C5, C8
25061-0200	LED - T1 ROUND (3mm) - RED	LED1
25115-0907	DIO 1N4002 B/R	D1-5
25117-0020	DIO 1N5401	D6
25336-5590	TRAN PNP BC559C	Q1
27001-0020	OPTO-COUPLER CNY17-3.	IC1-2
27103-0003	IC LM393	IC5
27160-0044	IC V/REG MIC2941ABT	IC3
27160-0900	IC V/REG 431TO-92	IC4
35555-3730	PCB - AUX TERM/POWER	

MECHANICAL ITEMS - QL355 & QL355P

Part Number	Description	Position
20010-0254	RIVET SNAP-LOCK 4.1D X 5.5T	FAN
20030-0240	WASHER 4BA ZPST	TERMINAL
20030-0263	WASHER M3 ZPST	REMOTE SENSE TO TERMINAL, POWER PCB, TERMINAL PCB, F/PANEL BRACKET TO POWER PCB, BARRIER BLOCK, BRACKET GPIB PCB
20030-0264	WASHER M2.5 ZPST	F/PANEL SUPPORT BRACKET
20037-0301	WASHER M3 SHK/PROOF I/T ZPST	F/PANEL TO CHASSIS, FAN TO CHASSIS, BRACKET TO CHASSIS.
20037-0304	WASHER M4 SHK/PROOF I/T ZPST	FRONT FEET
20037-0401	SOLDER TAG SHAKEPROOF - M4	EARTH

MECHANICAL ITEMS - QL355 & QL355P continued/...

Part Number	Description	Position
20038-9501	WASHER M3 SPRING	REMOTE SENSE TO TERMINAL, POWER PCB, TERMINAL PCB, F/PANEL BRACKET TO POWER PCB, BARRIER BLOCK, BRACKET GPIB PCB
20038-9502	WASHER M4 SPRING	EARTH
20038-9503	WASHER M3.5 SPRING	TERMINAL
20062-9301	SCREW No.4x3/8in. POZI PAN	FOR GPIB BRACKET
20063-0010	SCREW NO6 x 3/8in. NIB HDPZ ST/AB	TRANSFORMER, COVER
20065-0020	SCREW 2-28 x 5/16 PLAS PNHDPZ	KEYBOARD PCB, BRACKET
20134-9005	SCREW 4BA x 1/4in. POZI PAN	TERMINAL
20210-0101	NUT M3 ZPST	REMOTE SENSE TO TERMINAL, BARRIER BLOCK
20210-0102	NUT M4 ZPST	EARTH
20213-0040	CAPTIVE NUT SPIRE No.6	CHASSIS, TRANSFORMER, GPIB BRKT
20234-0012	SCREW M3 x 8 PNHDPZ ZPST	F/PANEL TO CHASSIS, FAN TO CHASSIS, REAR BRACKET TO CHASSIS, F/PANEL BRACKET TO POWER PCB, BRACKET GPIB PCB
20234-0016	SCREW M4 X 16 PNHDPZ ZPST	FEET
20234-0024	SCREW M3 X 16 PNHDPZ ZPST	TERMINAL PCB , REMOTE SENSE
20234-0025	SCREW M3 X 12 PNHDPZ ZPST	BARRIER BLOCK
20234-0027	SCREW M3 X 6 PNHDPZ ZPST	POWER PCB
20234-0028	SCREW M4 X 10 PNHDPZ ZPST	FRONT FEET
20236-0010	SCREW M4 X 12 TAMPERPROOF	EARTH
20611-0050	WASHER NYLON M2.5	KEYBOARD TO FRONT PANEL
20620-0010	CLIP - ENCODER KNOB	
20651-0016	CLIP CABLE RICHCO MWSEA2-2-01	MTG TO FAN BRKT
20661-0222	SPACER Hex M3 x 10 NPBR	FRONT PANEL SUPPORT BRACKET
20661-0225	SPACER Hex M3 x 12 NPBR	GPIB PCB TO GPIB SUPPORT
20661-0278	SPACER HEX 4BA x 9.53 NPBR	FRONT PANEL
20661-0282	SPACER Rnd 3.7 ID x 3.2 L NYLON	TERMINALS
20661-0290	SPACER Clr No.4 X 22.2mm NYLON	POWER TOP
20661-9111	SPACER Hex M3 x 6 NPBR	REMOTE SENSE PCB
20662-0570	FOOT SELF ADHESIVE GREY	FEET FRONT
20662-9101	INSTRUMENT FOOT	FEET BACK
22040-0030	FERRITE SLEEVE APPROX 8/16/14L	FOR OUTPUT LEADS, 6 SENSE WIRES REAR TERMINAL LEADS
		FOR FOR

MECHANICAL ITEMS - QL355 & QL355P continued/...

Part Number	Description	Position
22115-0490	TRANSFORMER	
22219-0090	SWITCH ROCKER DPST GREY	
22315-9502	FUSE 2A ANTISURGE HBC	
22467-0010	TERMINAL BARRIER BLOCK 4W 5A	REAR PANEL TERMINALS
22520-0200	AC RECEP 10AMP FUSED SNAP-IN	
22571-0675	TERMINAL TP/2 RED/GREY 12	
22571-0685	TERMINAL TP/2 BLACK/GREY 12	
22571-0691	WASHER ALUMINIUM FOR TP2E TERM	
22571-0696	TERMINAL TP/2 GREY/GREY	
22575-0009	SHORTING BLOCK	FIT TO SEL 4
22575-0077	SKT 2 WAY IDT .1P	FAN
22575-0205	SKT 5W .156 20AWG (Yellow)IDT	TX TO PWR PCB
22575-0206	SKT 6W .156 20AWG (Yellow)IDT	TX TO PWR PCB
23557-0506	CAP 10U 63V ELEC P2	FIT ACROSS R/PANEL TERMINALS
28522-0050	FAN 80MM 12VDC	
31512-0830	BRACKET R/PANEL TO PCB	
31512-0840	BRACKET FAN SUPPORT	
31512-0880	BRACKET F/PANEL TO CHASS	
33111-0250	BRACKET F/PANEL SUPPORT	
33143-0290	FOOT - TILT - HOUSING	FRONT FEET
33143-0300	FOOT - TILT - SUPPORT	FRONT FEET
33147-0290	FRONT MOULDING PTD	
33331-8010	OVERLAY TERM/NAME/LOGO	
33533-0430	LENS - DISPLAY	
33533-0440	WINDOW - DISPLAY	
33536-4350	CHASSIS PRINTED	QL
33536-4310	CHASSIS PRINTED	QL-P
33536-4320	COVER - PAINTED	
37151-0530	KNOB 32MM (QL) D-SHAFT L/GREY	
48511-0500	INSTRUCTION BOOK	

MECHANICAL ITEMS - QL355T & QL355TP

Part Number	Description	Position
20010-0254	RIVET SNAP-LOCK 4.1D X 5.5T	FAN
20030-0240	WASHER 4BA ZPST	TERMINAL
20030-0263	WASHER M3 ZPST	REMOTE SENSE TO TERMINAL, POWER PCB, TERMINAL PCB, F/PANEL BRACKET TO POWER PCB, BARRIER BLOCK, BRACKET GPIB PCB
20030-0264	WASHER M2.5 ZPST	F/PANEL SUPPORT BRACKET
20030-0266	WASHER M4 ZPST	FAN BRACKET
20037-0301	WASHER M3 SHK/PROOF I/T ZPST	F/PANEL TO CHASSIS, FAN TO CHASSIS, BRACKET TO CHASSIS
20037-0304	WASHER M4 SHK/PROOF I/T ZPST	FRONT FEET
20037-0401	SOLDER TAG SHAKEPROOF - M4	EARTH
20038-9501	WASHER M3 SPRING	REMOTE SENSE TO TERMINAL, POWER PCB, TERMINAL PCB, F/PANEL BRACKET TO POWER PCB, BARRIER BLOCK, BRACKET GPIB PCB
20038-9502	WASHER M4 SPRING	EARTH, FAN BRACKET
20038-9503	WASHER M3.5 SPRING	TERMINAL
20062-9301	SCREW No.4 x 3/8in. POZI PAN	FOR GPIB BRACKET
20063-0010	SCREW No.6 x 3/8in. NIB HDPZ ST/AB	TRANSFORMER, COVER
20065-0020	SCREW 2-28 x 5/16 PLAS PNHDPZ	KEYBOARD PCB, BRKT
20134-9005	SCREW 4BA x 1/4in. POZI PAN	TERMINAL
20210-0101	NUT M3 ZPST	REMOTE SENSE TO TERMINAL, BARRIER BLOCK
20210-0102	NUT M4 ZPST	EARTH, FAN BRACKET
20213-0040	CAPTIVE NUT SPIRE NO.6	CHASSIS, TRANSFORMER, GPIB BRKT
20234-0012	SCREW M3 x 8 PNHDPZ ZPST	F/PANEL TO CHASSIS, FAN TO CHASSIS, REAR BRACKET TO CHASSIS, F/PANEL BRACKET TO POWER PCB, BRACKET GPIB PCB
20234-0016	SCREW M4 x 16 PNHDPZ ZPST	FEET
20234-0024	SCREW M3 x 16 PNHDPZ ZPST	TERMINAL PCB, REMOTE SENSE
20234-0025	SCREW M3 x 12 PNHDPZ ZPST	BARRIER BLOCK
20234-0027	SCREW M3 x 6 PNHDPZ ZPST	POWER PCB
20234-0028	SCREW M4 x 10 PNHDPZ ZPST	FRONT FEET
20234-0029	SCREW M4 x 12 PNHDPZ ZPST	FAN BRACKET
20236-0010	SCREW M4 x 12 TAMPERPROOF	EARTH
20611-0050	WASHER NYLON M2.5	KEYBOARD TO FRONT PANEL
20620-0010	CLIP - ENCODER KNOB	

MECHANICAL ITEMS - QL355T & QL355TP continued/...

Part Number	Description	Position
20651-0016	CLIP CABLE RICHCO MWSEA2-2-01	MTG TO FAN BRKT
20661-0222	SPACER Hex M3 x 10 NPBR	FRONT PANEL SUPPORT BRACKET
20661-0250	SPACER Rnd M4 CI x 5 NPBR	FAN BRACKET
20661-0278	SPACER HEX 4BA X 9.53 NPBR	FRONT PANEL
20661-0282	SPACER Rnd 3.7 ID x 3.2 L Nyl	TERMINALS
20661-0290	SPACER Clr No.4 X 22.2mm Nylon	POWER TOP
20661-9111	SPACER Hex M3 x 6 NPBR	REMOTE SENSE PCB
20662-0570	FOOT SELF ADHESIVE GREY	FRONT FEET
20662-9101	INSTRUMENT FOOT	BACK FEET
22040-0030	FERRITE SLEEVE APPROX 8/16/14L	FOR OUTPUT LEADS, FOR 6 SENSE WIRES, FOR REAR TERMINAL LEADS
22115-0490	TRANSFORMER - QL355	
22219-0090	SWITCH ROCKER DPST GREY	
22315-9503	FUSE 4A ANTISURGE HBC	230V
22315-0250	FUSE 8A ANTISURGE HBC	115V
22467-0010	TERMINAL BARRIER BLOCK 4W 5A	REAR PANEL TERMINALS
22491-0120	MAINS LD 2M ST IEC/UK PLUG 5A	
22491-0270	MAINS LD 2M ST IEC/EUR PLUG	
22491-0040	MAINS LD 2M ST IEC/USA PLUG	
22520-0200	AC RECEP 10AMP FUSED SNAP-IN	
22571-0675	TERMINAL TP/2 RED/GREY 12	
22571-0685	TERMINAL TP/2 BLACK/GREY 12	
22571-0691	WASHER ALUMINIUM FOR TP2E TERM	
22571-0696	TERMINAL TP/2 GREY/GREY	
22575-0009	SHORTING BLOCK	FIT TO MASTER SEL 3
22575-0077	SKT 2 WAY IDT .1P	FAN, POWER TO POWER
22575-0078	SKT 3 WAY IDT .1P	POWER TO POWER
22575-0079	SKT 4 WAY IDT .1P	SLAVE POWER TO AUX POWER
22575-0205	SKT 5W .156 20AWG (Yellow)IDT	TX TO PWR PCB
22575-0206	SKT 6W .156 20AWG (Yellow)IDT	TX TO PWR PCB
23557-0506	CAP 10U 63V ELEC P2	FIT ACROSS REAR TERMINALS
28522-0050	FAN 80MM 12VDC	
31512-0820	BRACKET F.PNL/CHASS QL TRIPLE	
31512-0830	BRACKET R/PANEL TO PCB QL	
31512-0840	BRACKET FAN SUPPORT QL	
33111-0250	BRACKET F/PANEL SUPPORT QL	

MECHANICAL ITEMS - QL355T & QL355TP continued/...

Part Number	Description	Position
33143-0290	FOOT - TILT - HOUSING	FEET FRONT
33143-0300	FOOT - TILT - SUPPORT	FEET FRONT
33147-0270	FRONT MOULDING PTD	
33331-8110	OVERLAY TERM/NAM/LOG	
33533-0430	LENS - DISPLAY	
33533-0440	WINDOW - DISPLAY	
33536-4360	CHASSIS - PRINTED	QLT
33536-4290	CHASSIS - PRINTED	QLT-P
33536-4300	COVER PAINTED	
37151-0530	KNOB 32MM D-SHAFT L/GREY	
47511-0010-L	KEYPAD - LEFT	
47511-0010-R	KEYPAD - RIGHT	
48511-0560	INSTRUCTION BOOK	

MECHANICAL ITEMS - QL564/564P

Part Number	Description	Position
20010-0254	RIVET SNAP-LOCK 4.1D X 5.5T	FAN
20030-0240	WASHER 4BA ZPST	TERMINAL
20030-0263	WASHER M3 ZPST	REMOTE SENSE TO TERMINAL, POWER PCB, TERMINAL PCB, F/PANEL BRACKET TO POWER PCB, BARRIER BLOCK, BRACKET GPIB PCB
20030-0264	WASHER M2.5 ZPST	F/PANEL SUPPORT BRACKET
20037-0301	WASHER M3 SHK/PROOF I/T ZPST	F/PANEL TO CHASSIS (2), FAN TO CHASSIS (2), BRACKET TO CHASSIS (2)
20037-0304	WASHER M4 SHK/PROOF I/T ZPST	FRONT FEET
20037-0401	SOLDER TAG SHAKEPROOF - M4	EARTH
20038-9501	WASHER M3 Spring	REMOTE SENSE TO TERMINAL, POWER PCB, TERMINAL PCB, F/PANEL BRACKET TO POWER PCB, BARRIER BLOCK, BRACKET GPIB PCB
20038-9502	WASHER M4 Spring	EARTH
20038-9503	WASHER M3.5 SPRING	TERMINAL
20062-9301	SCREW No.4 x 3/8in. Pozi. Pan	FOR GPIB BRACKET
20063-0010	SCREW No.6 x 3/8 NIB HDPZ ST/AB	TRANSFORMER, COVER
20065-0020	SCREW 2-28 x 5/16 PLAS PNHDPZ	KEYBOARD PCB, BRKT
20134-9005	SCREW 4BA x 1/4in. Pozi Pan	TERMINAL
20210-0101	NUT M3 ZPST	REMOTE SENSE TO TERMINAL, BARRIER BLOCK
20210-0102	NUT M4 ZPST	EARTH
20213-0040	CAPTIVE NUT SPIRE NO.6	CHASSIS, TRANSFORMER, GPIB BRKT

MECHANICAL ITEMS - QL564/564P continued/...

Part Number	Description	Position
20234-0012	SCREW M3 X 8 PNHDPZ ZPST	F/PANEL TO CHASSIS, FAN TO CHASSIS, REAR BRACKET TO CHASSIS F/PANEL BRACKET TO POWER PCB, BRACKET GPIB PCB
20234-0016	SCREW M4 X 16 PNHDPZ ZPST	FEET
20234-0024	SCREW M3 X 16 PNHDPZ ZPST	TERMINAL PCB, REMOTE SENSE
20234-0025	SCREW M3 X 12 PNHDPZ ZPST	BARRIER BLOCK
20234-0027	SCREW M3 X 6 PNHDPZ ZPST	POWER PCB
20234-0028	SCREW M4 X 10 PNHDPZ ZPST	FRONT FEET
20236-0010	SCREW M4 X 12 TAMPERPROOF	EARTH
20611-0050	WASHER NYLON M2.5	KEYBOARD TO FRONT PANEL
20620-0010	CLIP - ENCODER KNOB	
20651-0016	CLIP CABLE RICHCO MWSEA2-2-01	MTG TO FAN BRKT
20653-0204	CABLE TIE 100 X 2.5MM	MAINS TO CHASSIS, TERMINAL PCB
20661-0222	SPACER Hex M3 x 10 NPBR	FRONT PANEL SUPPORT BRACKET
20661-0278	SPACER HEX 4BA X 9.53 NPBR	FRONT PANEL
20661-0282	SPACER Rnd 3.7 ID x 3.2 L Nyl	TERMINALS
20661-0290	SPACER Clr No.4 X 22.2mm Nyl	POWER TOP
20661-9111	SPACER Hex M3 x 6 NPBR	REMOTE SENSE PCB
20662-0570	FOOT SELF ADHESIVE GREY	FRONT FEET
20662-9101	INSTRUMENT FOOT	BACK FEET
22040-0030	FERRITE SLEEVE APPROX 8/16/14L	FOR OUTPUT LEADS 6 SENSE WIRES FOR REAR TERMINAL LEADS
22115-0670	TRANSFORMER - QL564	
22219-0090	SWITCH ROCKER DPST GREY	
22315-9502	FUSE 2A ANTI SURGE HBC	230V
22315-9503	FUSE 4A ANTI SURGE HBC	115V
22467-0010	TERMINAL BARRIER BLOCK 4W 5A	REAR PANEL TERMINALS
22491-0120	MAINS LD 2M ST IEC/UK PLUG 5A	
22491-0270	MAINS LD 2M ST IEC/EUR PLUG	
22491-0040	MAINS LD 2M ST IEC/USA PLUG	
22520-0200	AC RECEP 10AMP FUSED SNAP-IN	
22571-0675	TERMINAL TP/2 RED/GREY 12	
22571-0685	TERMINAL TP/2 BLACK/GREY 12	
22571-0691	WASHER ALUMINIUM FOR TP2E TERM	
22571-0696	TERMINAL TP/2 GREY/GREY	

MECHANICAL ITEMS - QL564/564P continued/...

Part Number	Description	Position
22575-0009	SHORTING BLOCK	FIT TO SEL 4 & 6
22575-0077	SKT 2 WAY IDT .1P	FAN
22575-0205	SKT 5W .156 20AWG (Yellow)IDT	TX TO PWR PCB
22575-0206	SKT 6W .156 20AWG (Yellow)IDT	TX TO PWR PCB
23557-0506	CAP 10U 63V ELEC P2	FIT ACROSS R/PANEL TERMINALS
28522-0050	FAN 80MM 12VDC (QL)	
31512-0830	BRACKET R/PANEL TO PCB	
31512-0840	BRACKET FAN SUPPORT	
31512-0880	BRACKET F/PANEL TO CHASS	
33111-0250	BRACKET F/PANEL SUPPORT	
33143-0290	FOOT - TILT - HOUSING	FRONT FEET
33143-0300	FOOT - TILT - SUPPORT	FRONT FEET
33147-0290	FRONT MOULDING PTD	
33331-8130	O/L TERMINAL/NAME/LOGO	
33533-0430	LENS - DISPLAY	
33533-0440	WINDOW - DISPLAY	
33536-4350	CHASSIS PRINTED	QL
33536-4310	CHASSIS PRINTED	QL-P
33536-4320	COVER - PAINTED	
37151-0530	KNOB 32MM (QL) D-SHAFT L/GREY	
47511-0020	KEYPAD - QL SINGLE	
48511-0500	INSTRUCTION BOOK	

Block Diagram

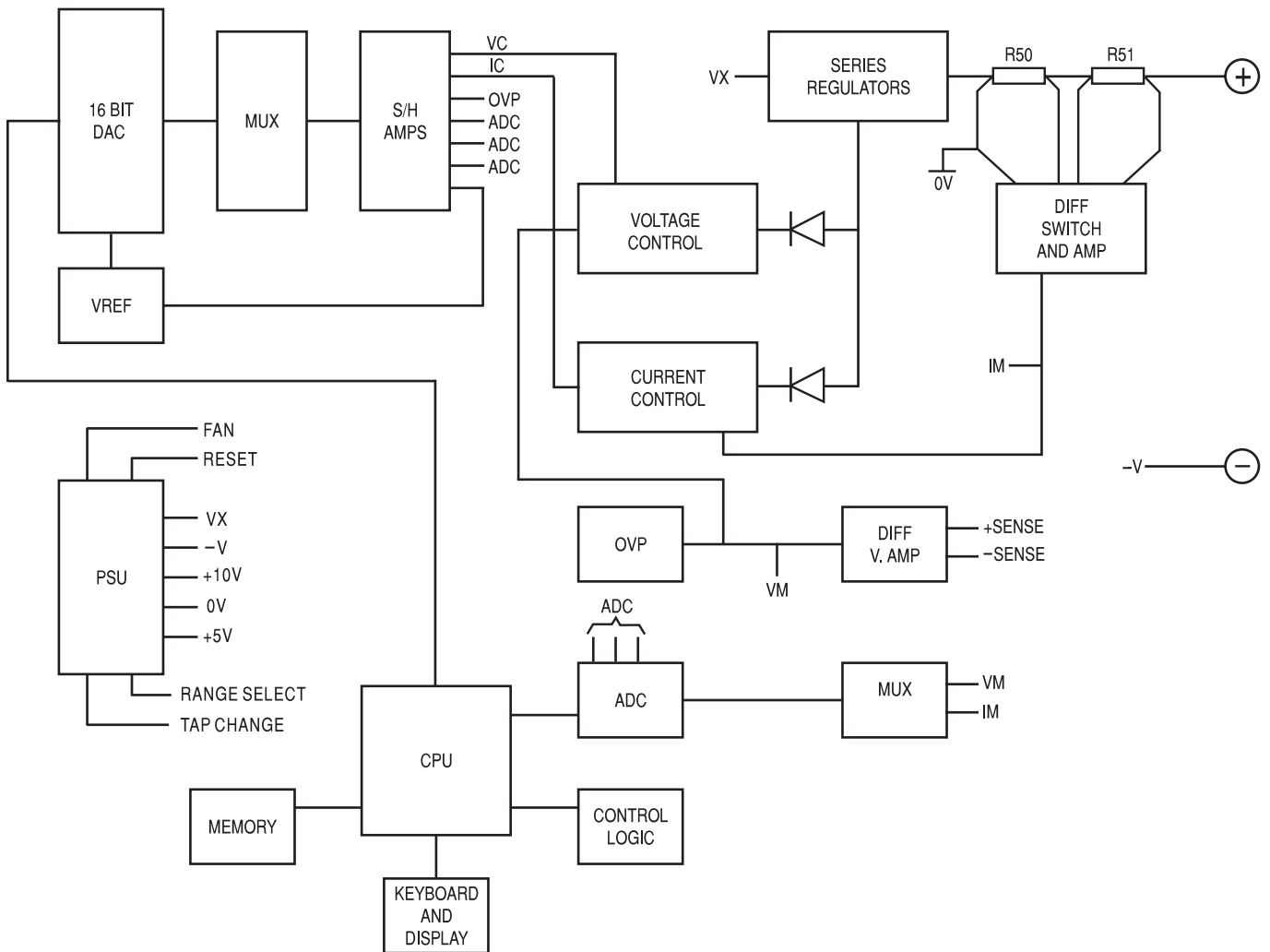

Interconnection Diagram

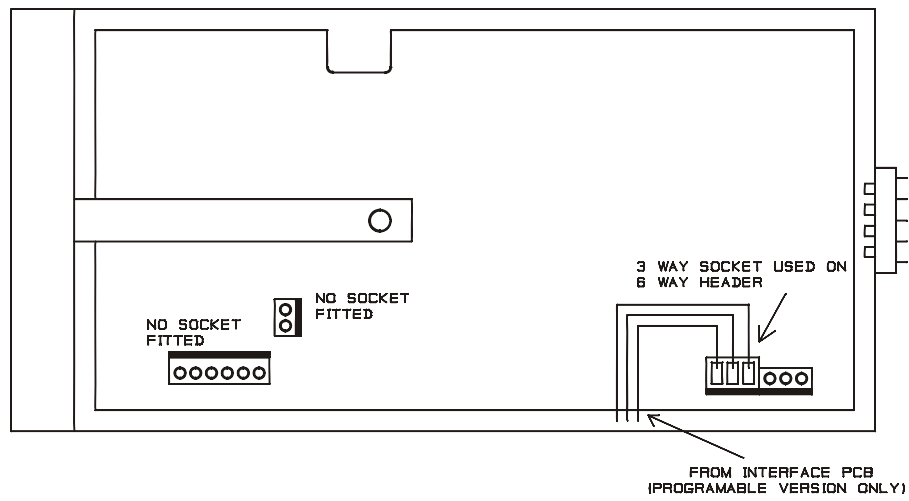

Single PSU

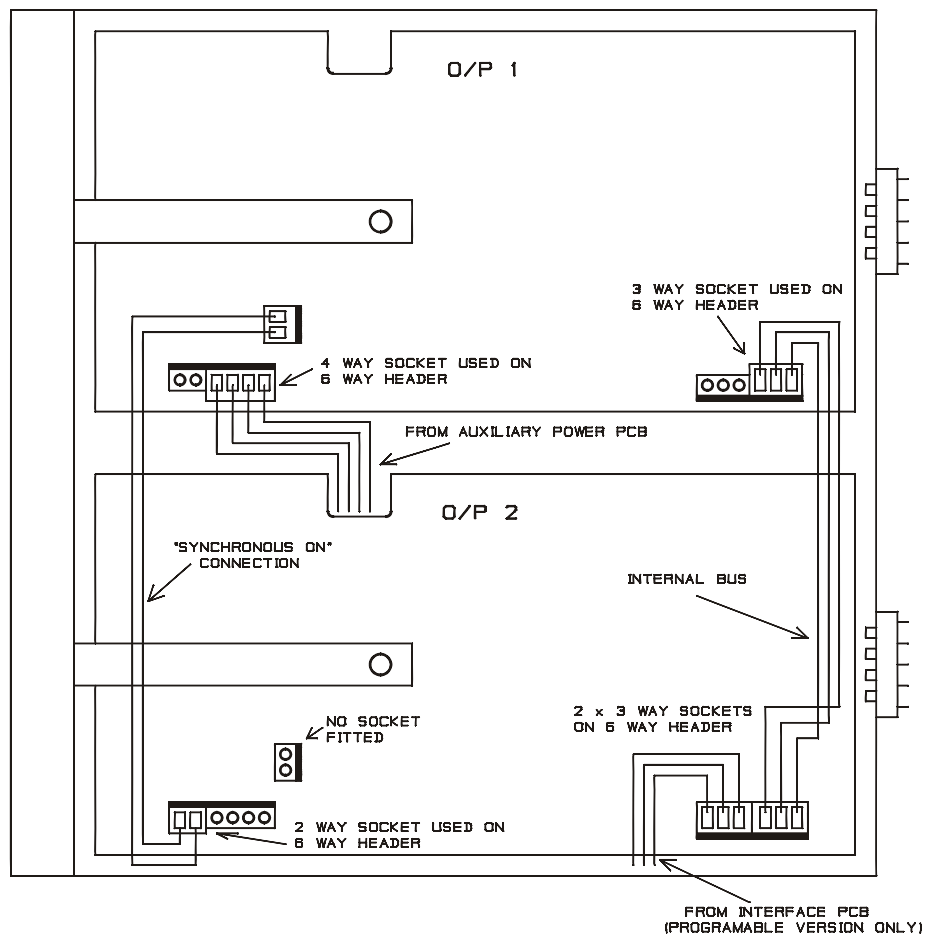

Triple PSU

Component Layouts

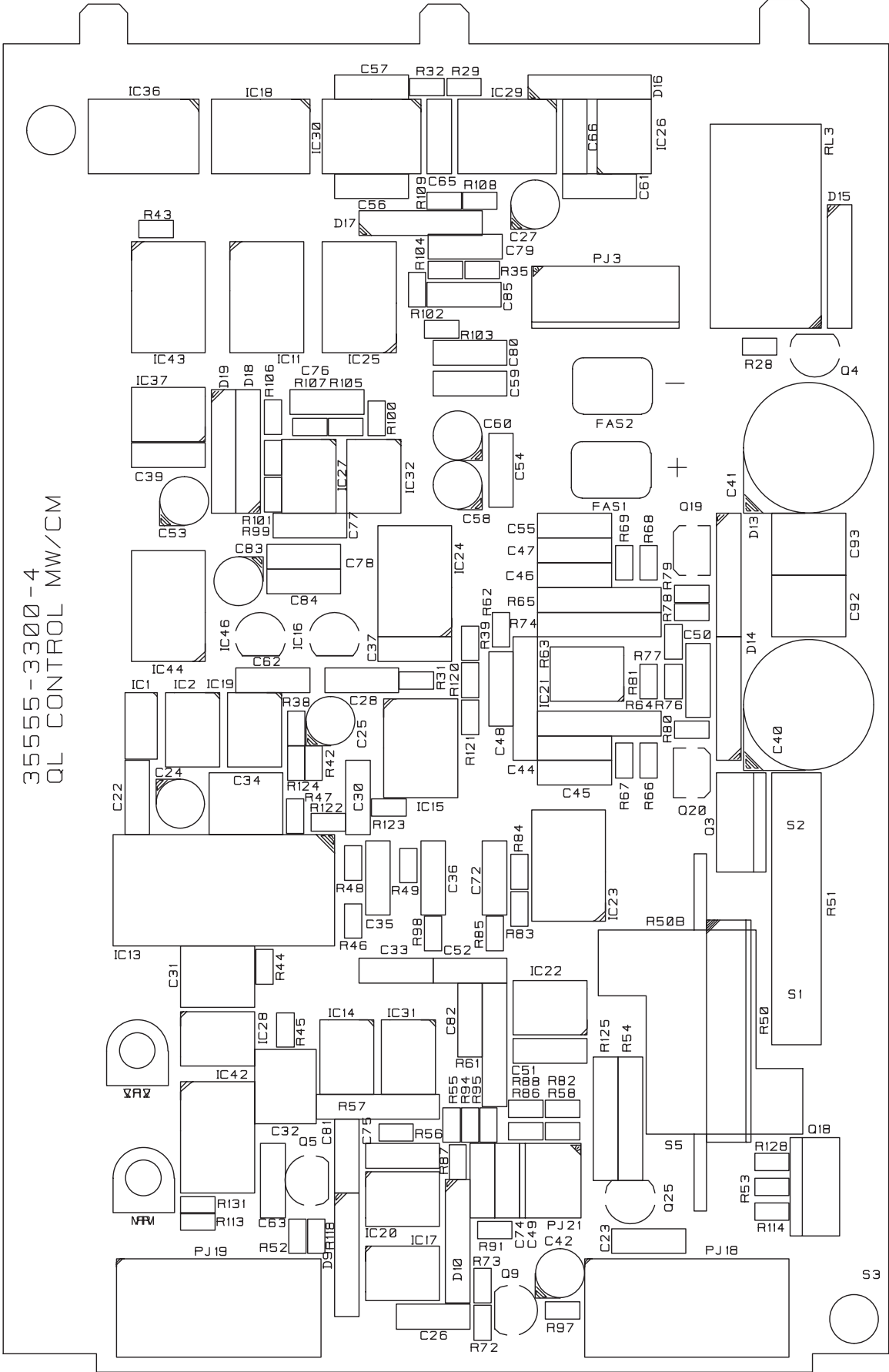

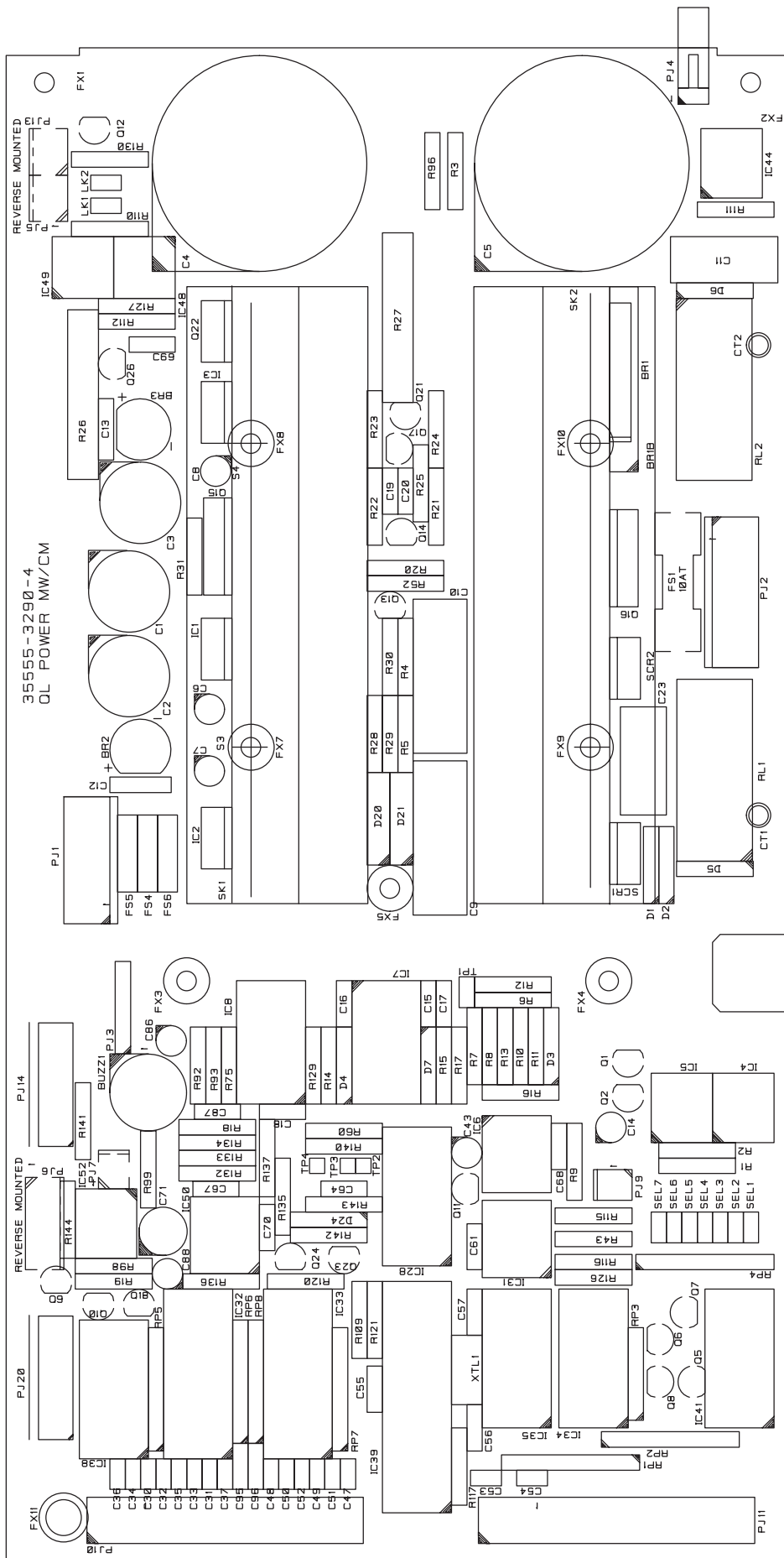

Power Pcb

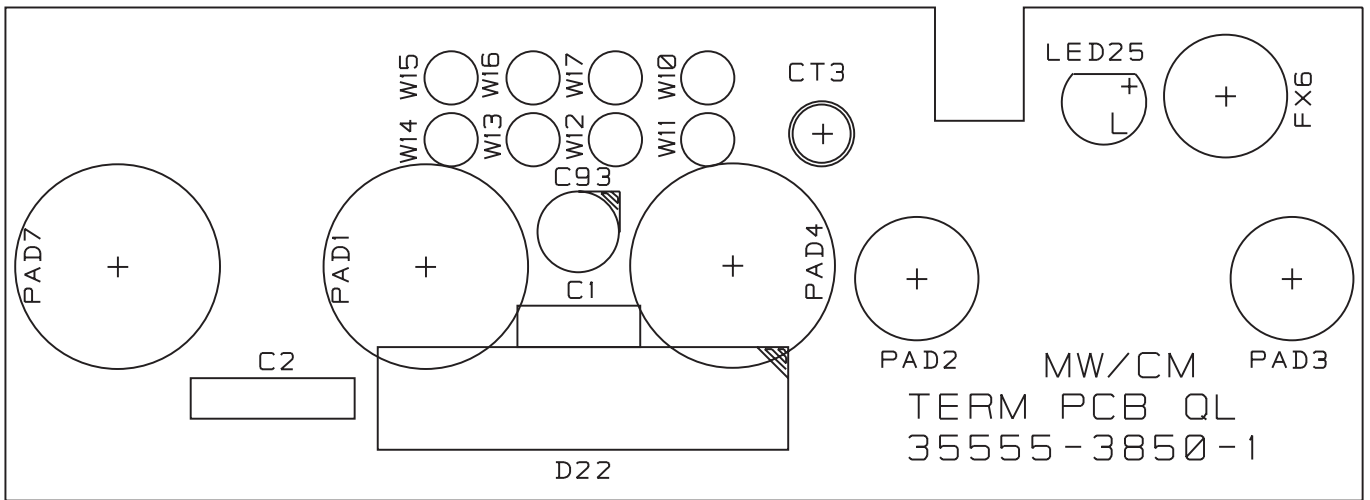

Main Terminal Pcb

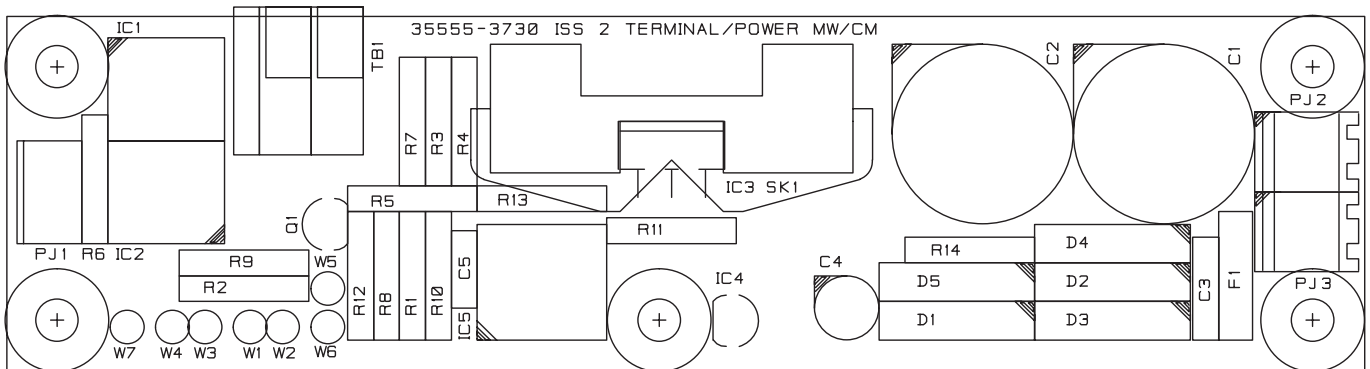

Auxiliary Power Pcb (Triple only)

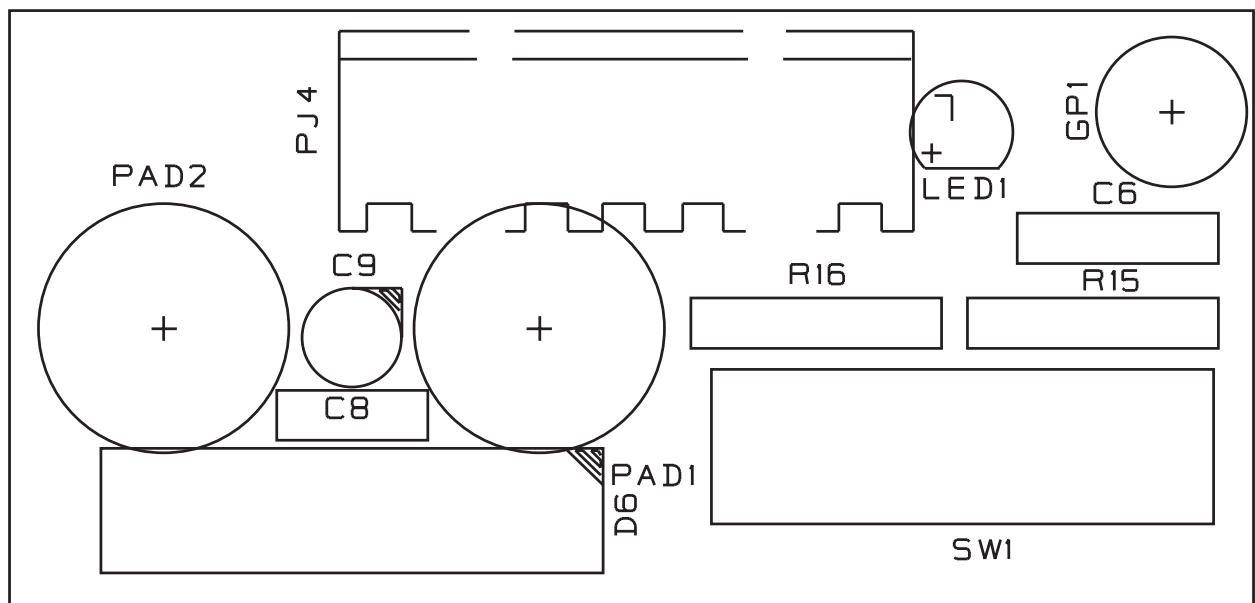

Auxiliary Terminal Pcb (Triple only)

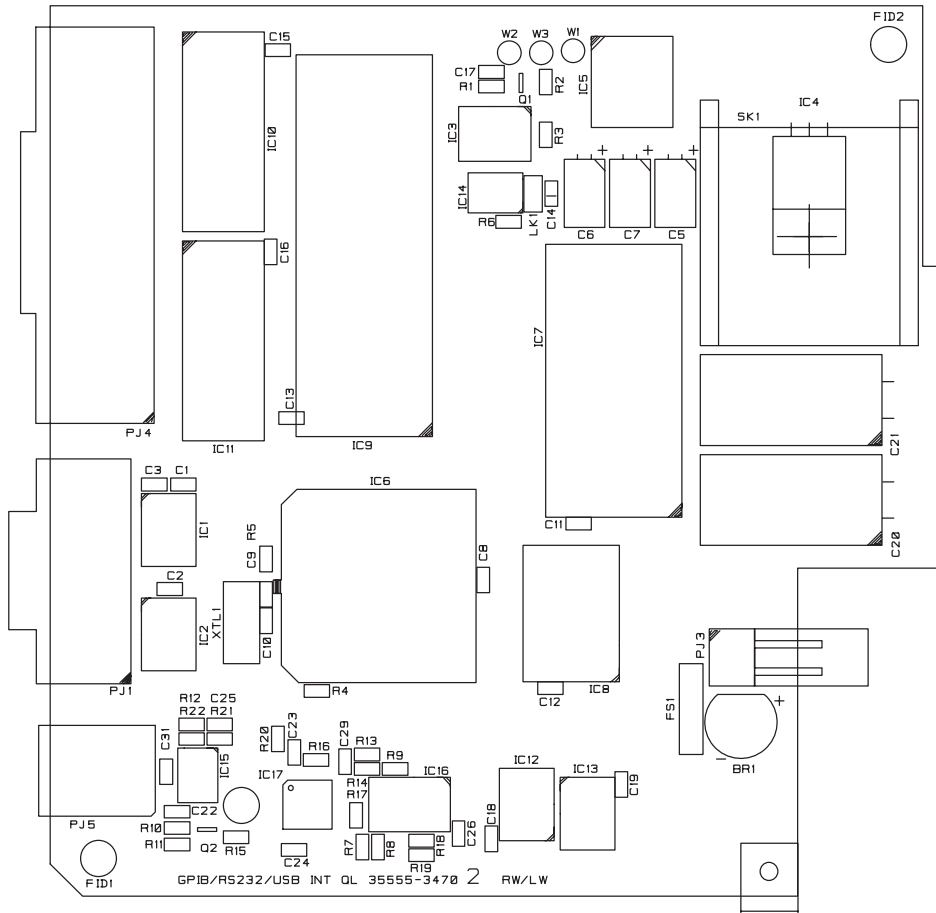

Interface Pcb

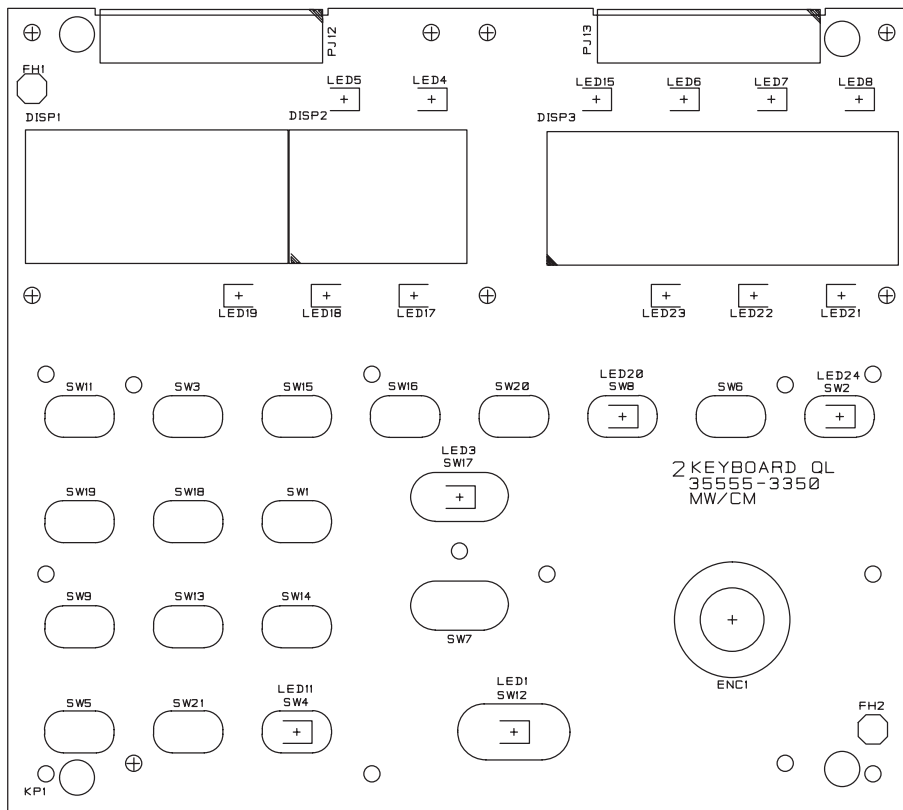

Keyboard/Display Pcb (Single)

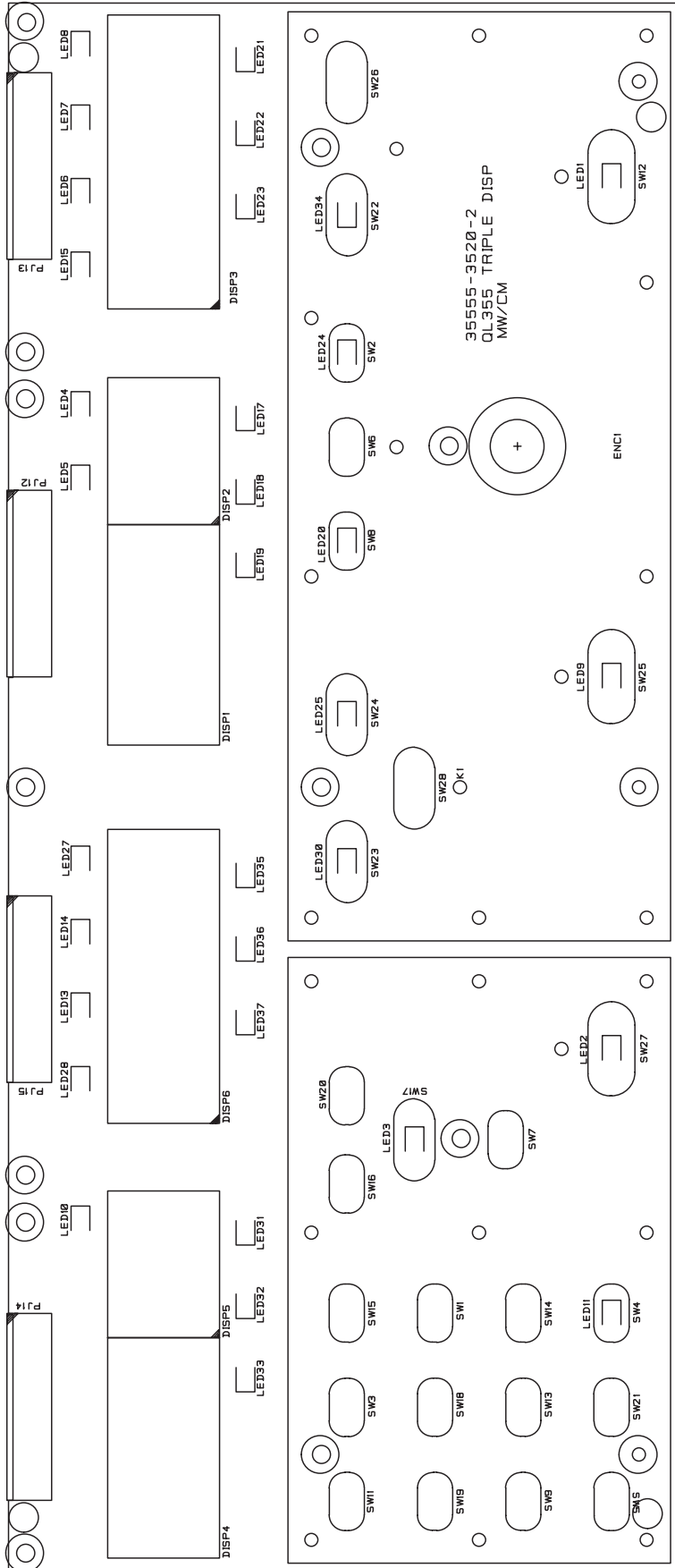

Keyboard/Display Pcb (Triple)

Circuit Diagrams

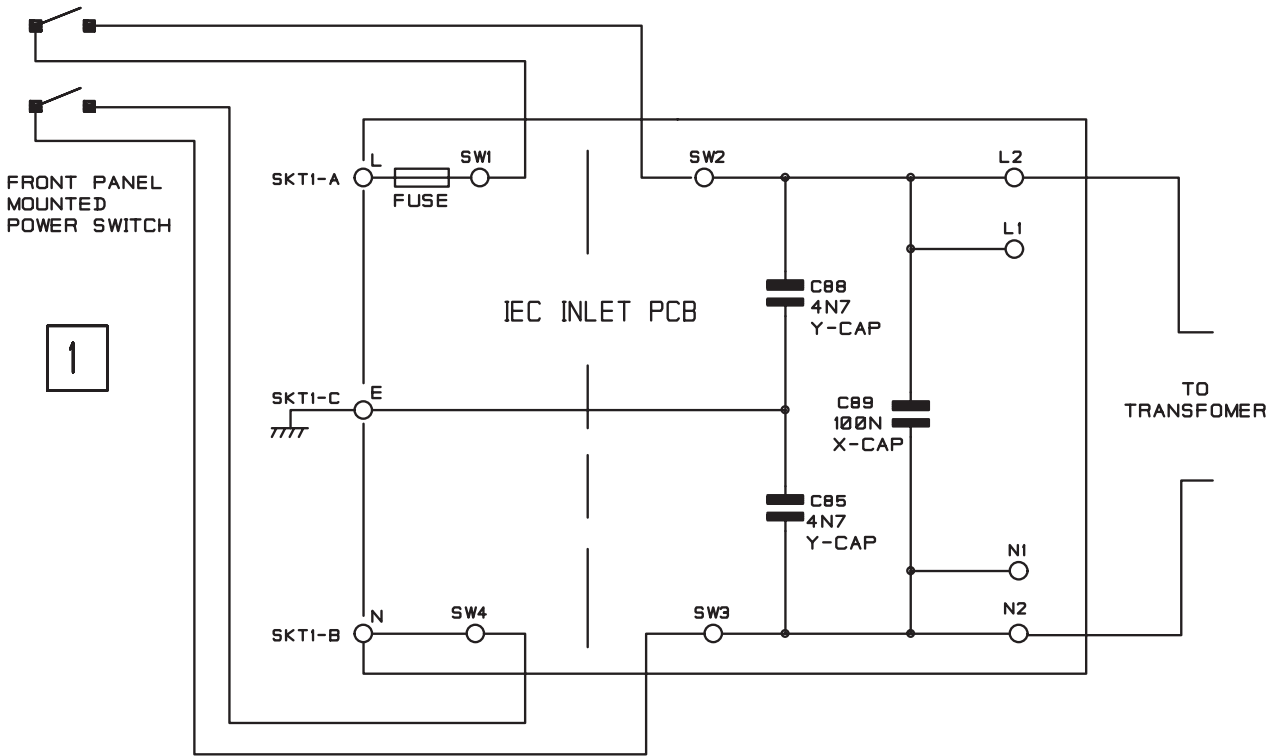

AC Supply Connection Pcb

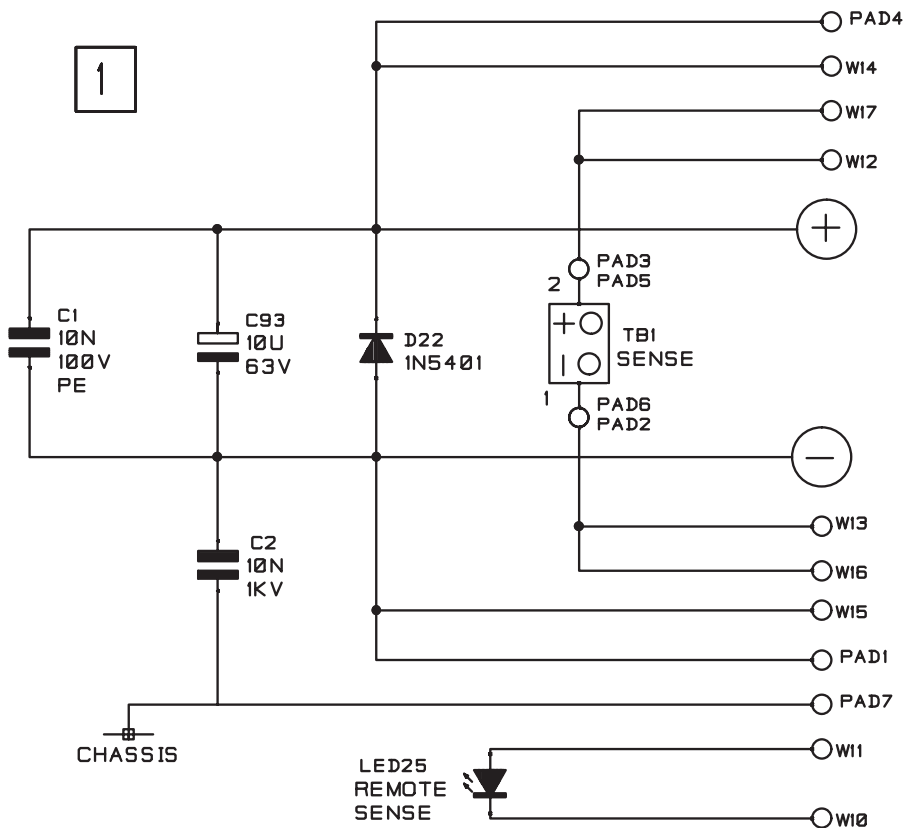

Main Output Front Panel Terminal Pcb

NOTE 1. IC1 FITTED UP TO ISSUE 3 PCB. EITHER IC1 OR IC2 FITTED TO ISSUE 4 ONWARDS

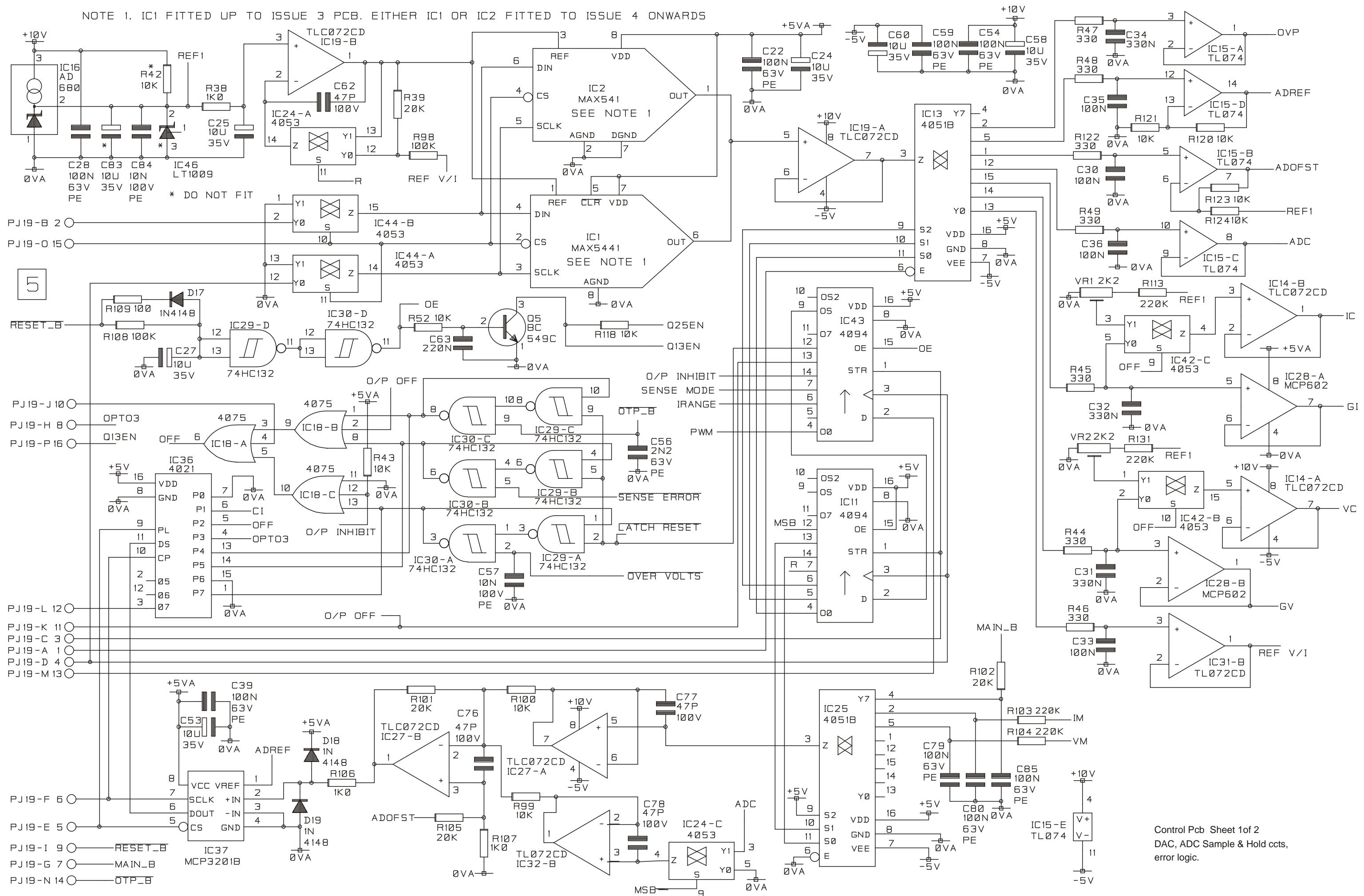

5

- PJ19-B 2
- PJ19-O 15
- RESET_B
- PJ19-J 10
- PJ19-H 8
- PJ19-P 16
- PJ19-L 12
- PJ19-K 11
- PJ19-C 3
- PJ19-A 1
- PJ19-D 4
- PJ19-M 13
- PJ19-F 6
- PJ19-E 5
- PJ19-I 9
- PJ19-G 7
- PJ19-N 14

5

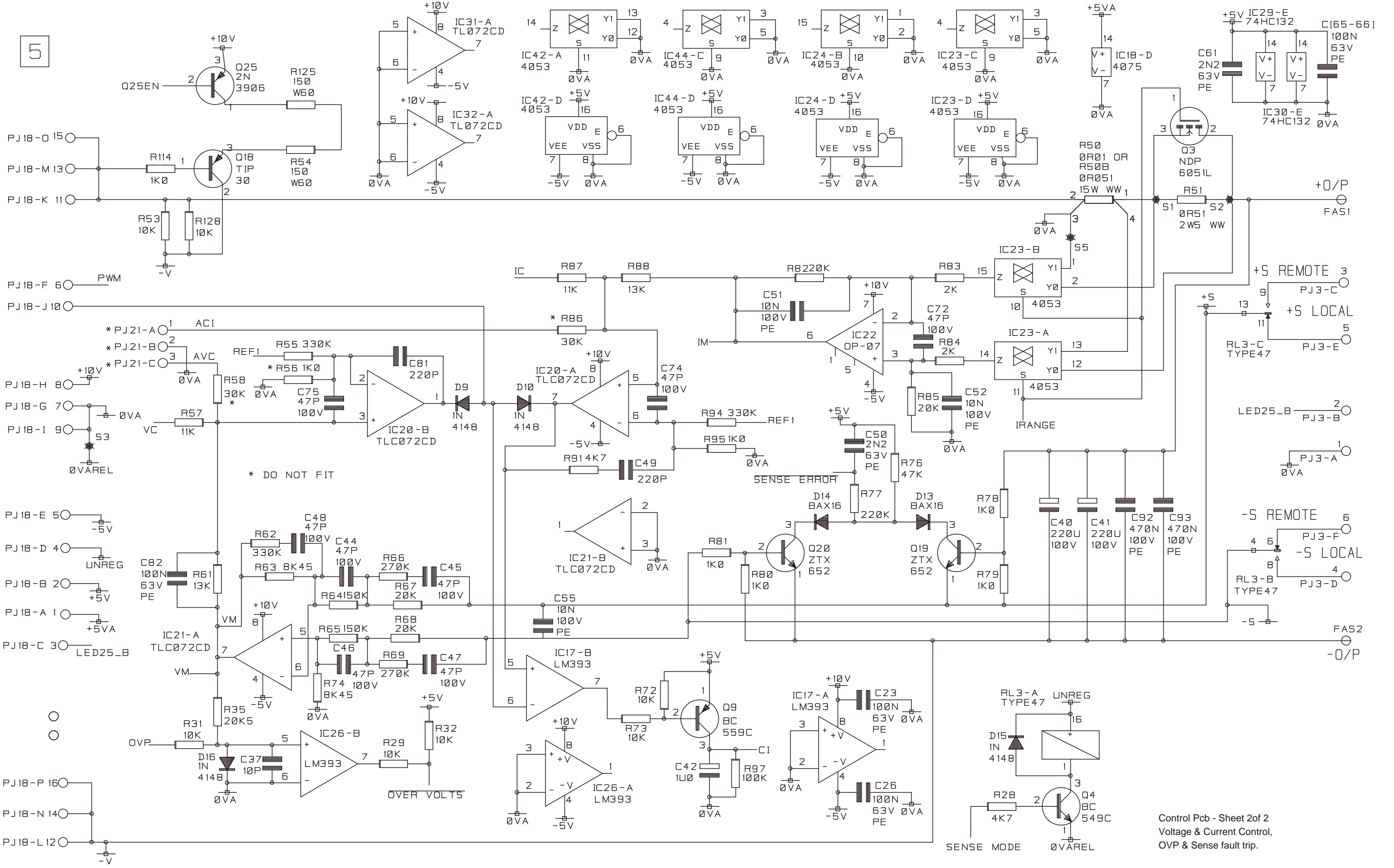

Control Pcb - Sheet 2of 2
 Voltage & Current Control,
 OVP & Sense fault trip.

3

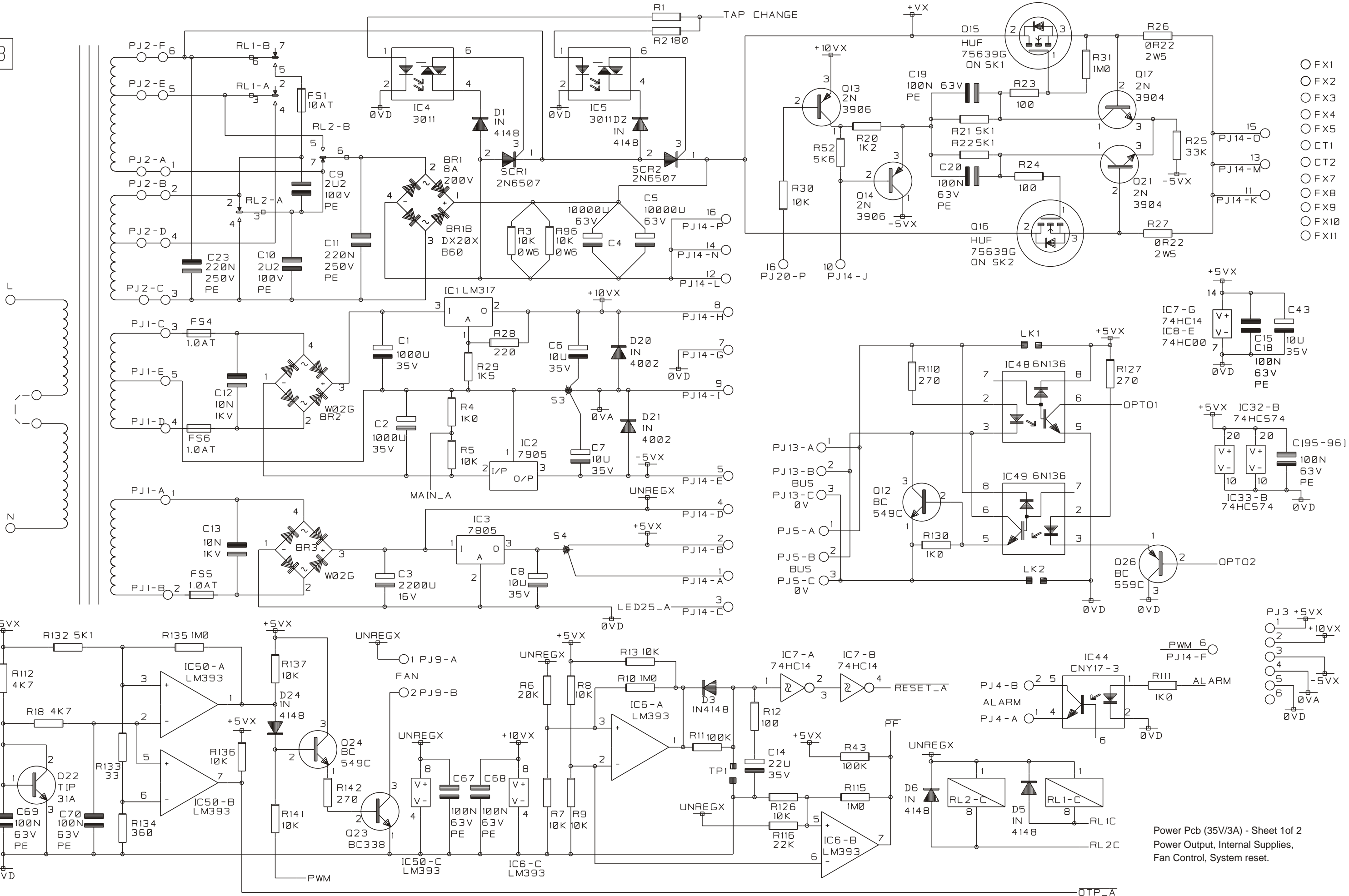

- FX1
- FX2
- FX3
- FX4
- FX5
- CT1
- CT2
- FX7
- FX8
- FX9
- FX10
- FX11

Power Pcb (35V/3A) - Sheet 1 of 2
 Power Output, Internal Supplies,
 Fan Control, System reset.

OTP_A

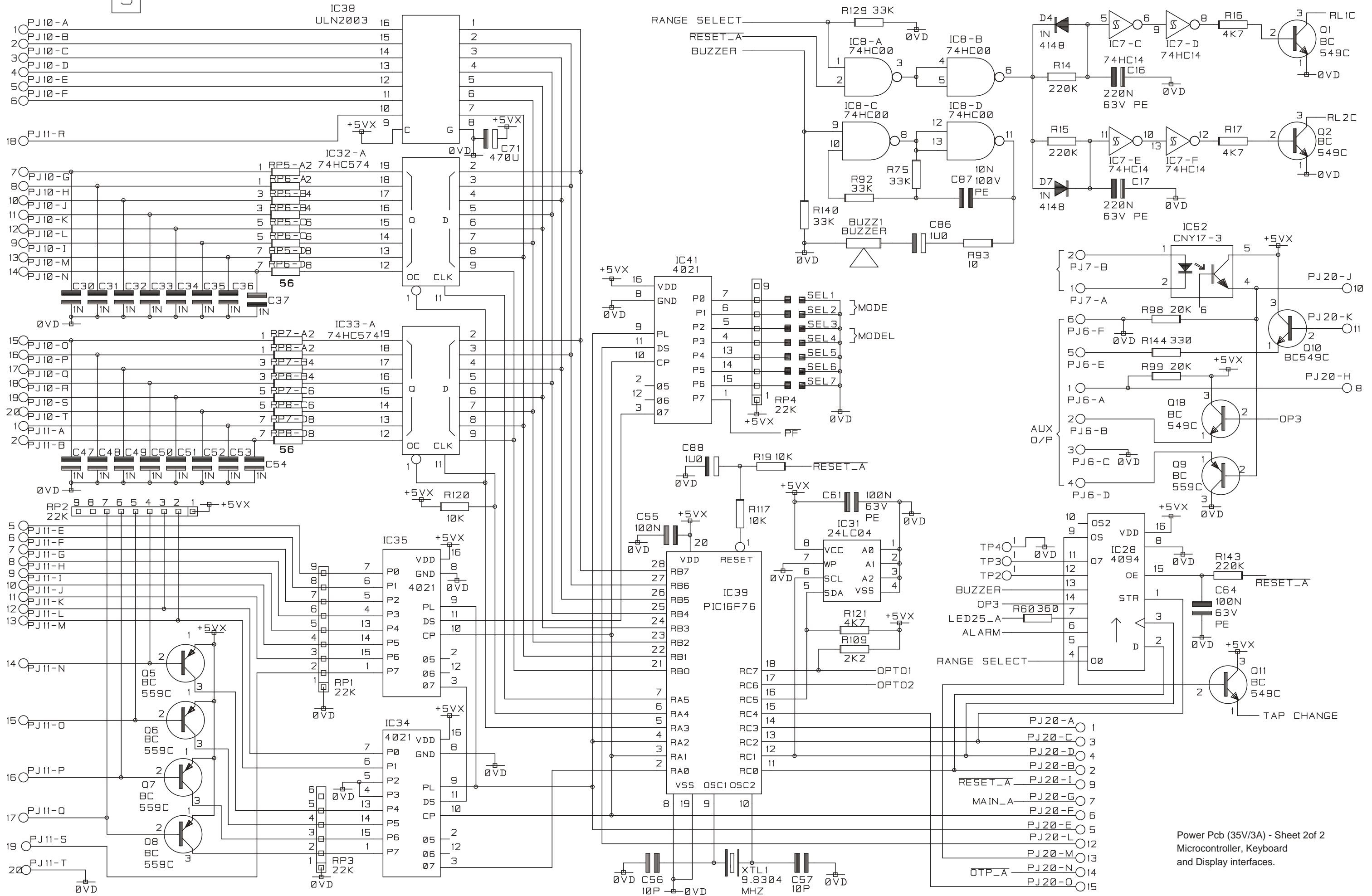

Power Pcb (35V/3A) - Sheet 2of 2
Microcontroller, Keyboard
and Display interfaces.

2

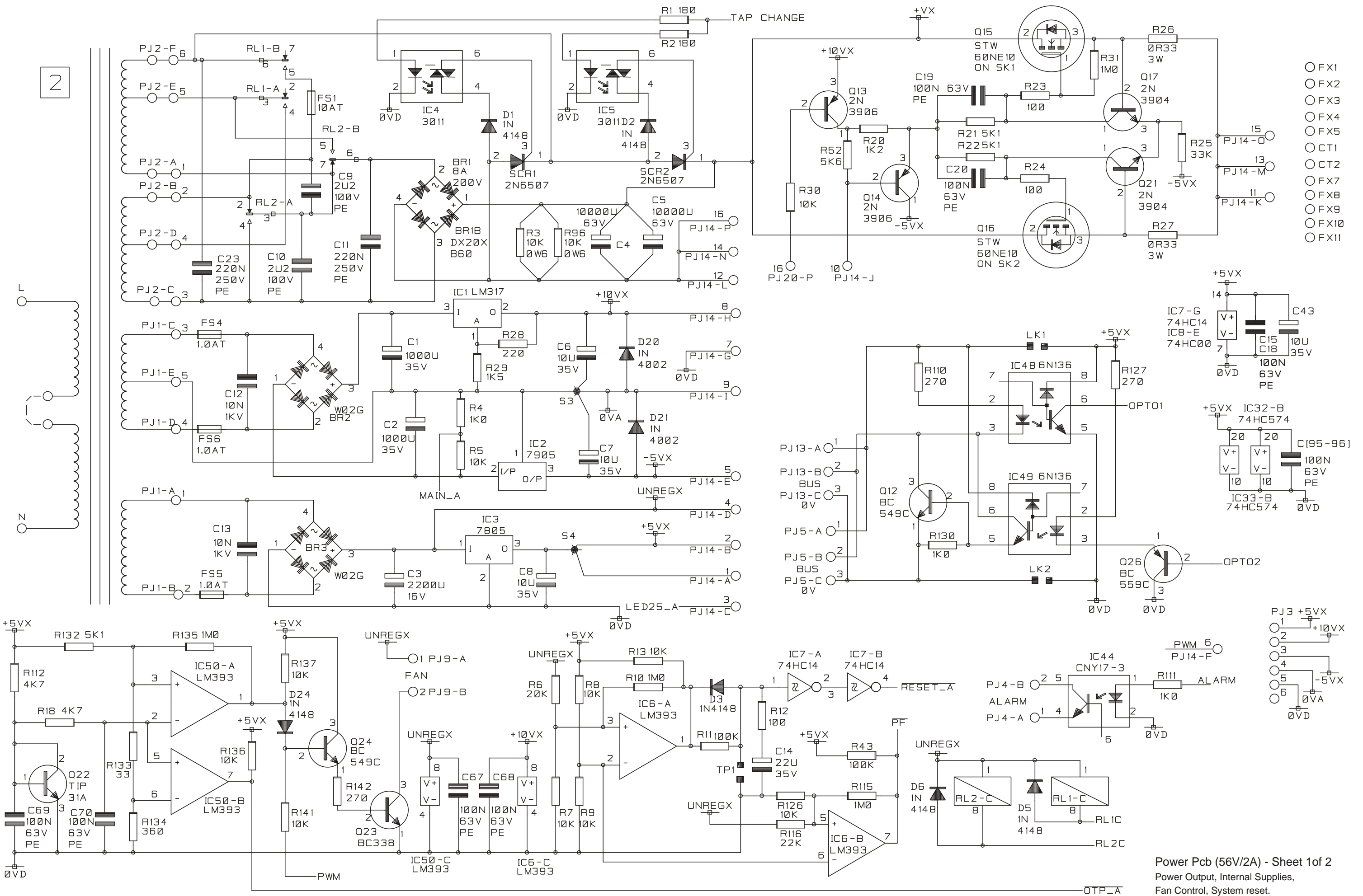

- FX1
- FX2
- FX3
- FX4
- FX5
- CT1
- CT2
- FX7
- FX8
- FX9
- FX10
- FX11

Power Pcb (56V/2A) - Sheet 1of 2
 Power Output, Internal Supplies,
 Fan Control, System reset.

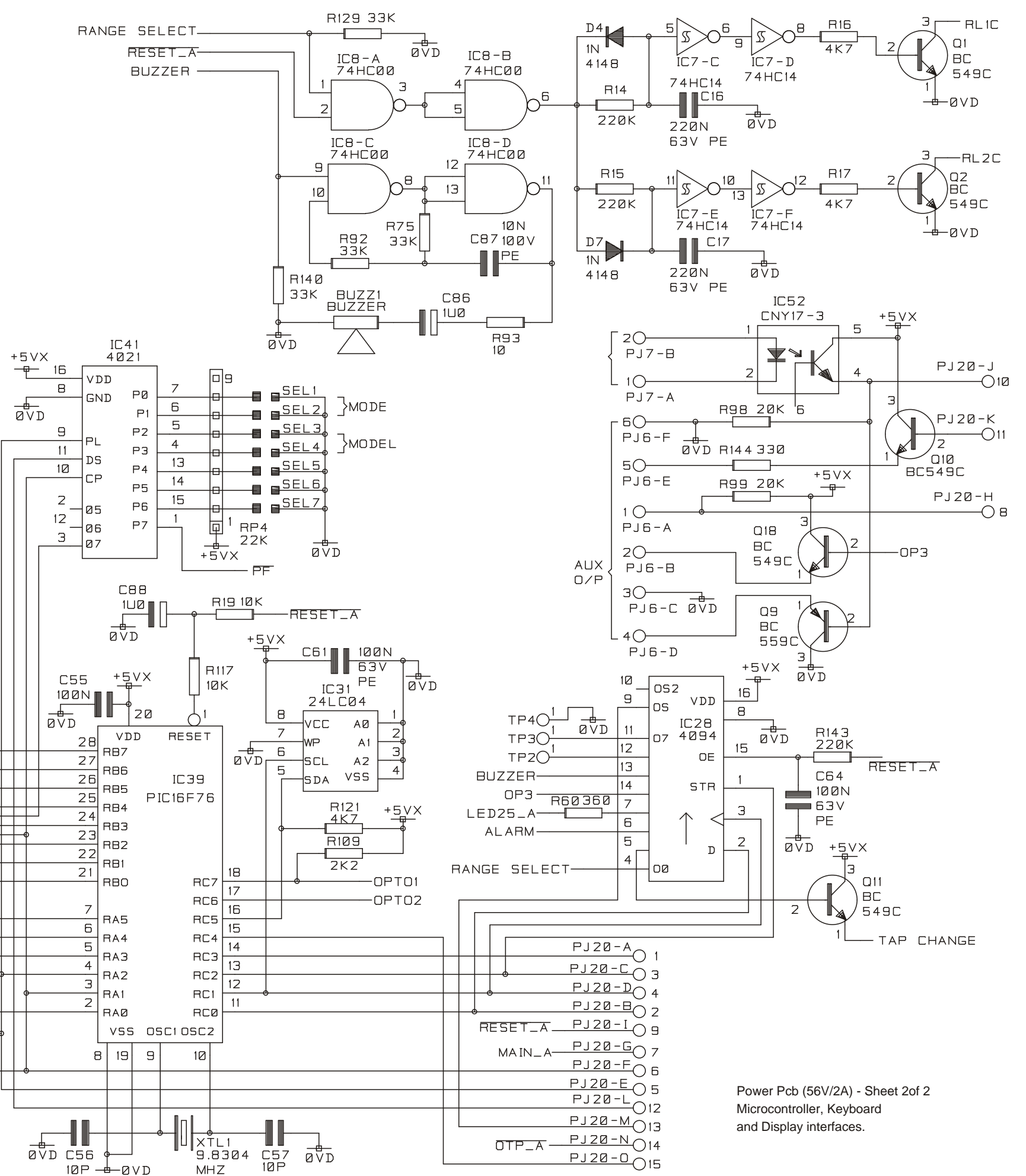
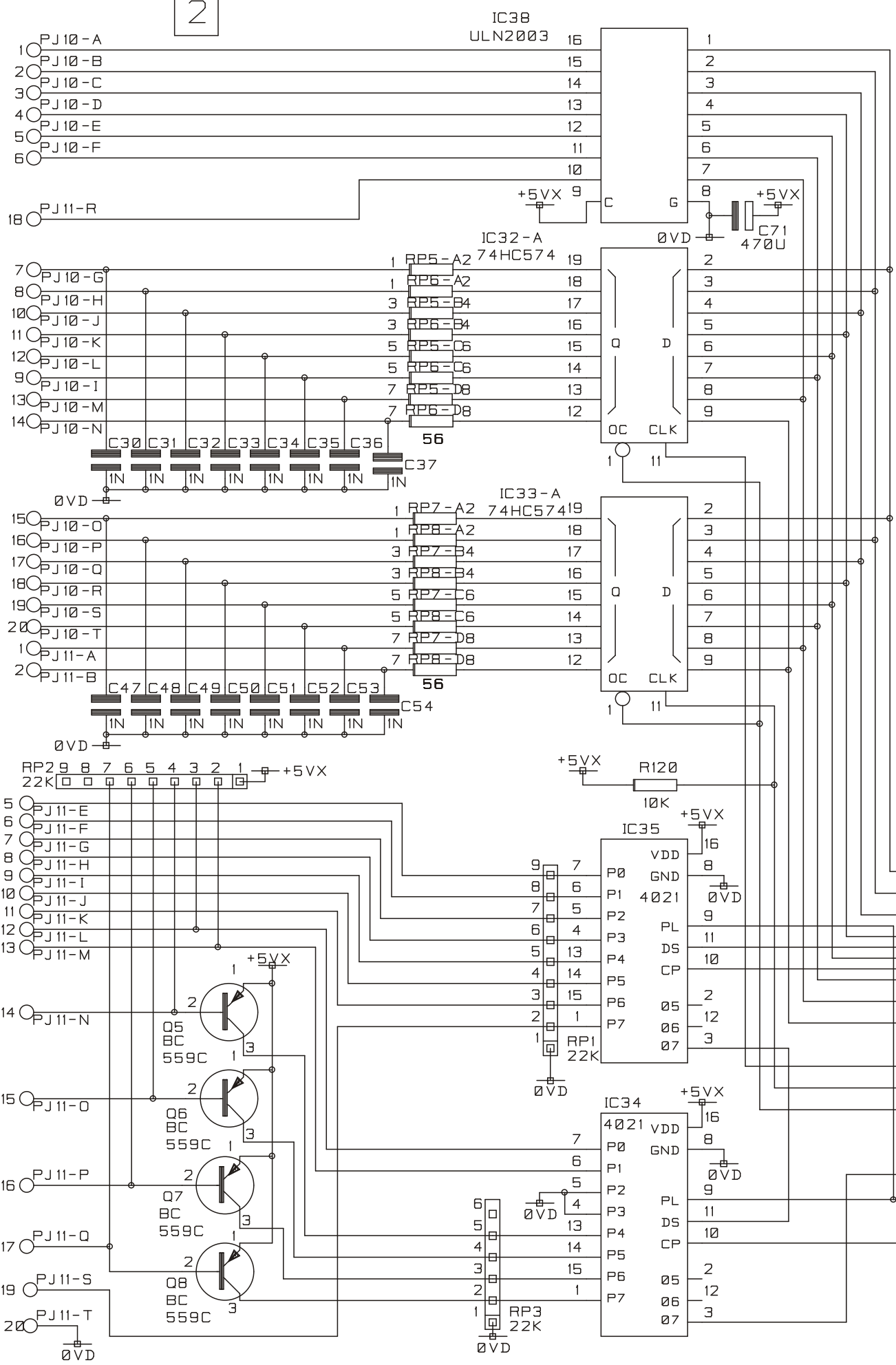

Power Pcb (56V/2A) - Sheet 2of 2
Microcontroller, Keyboard
and Display interfaces.

* DO NOT FIT

3

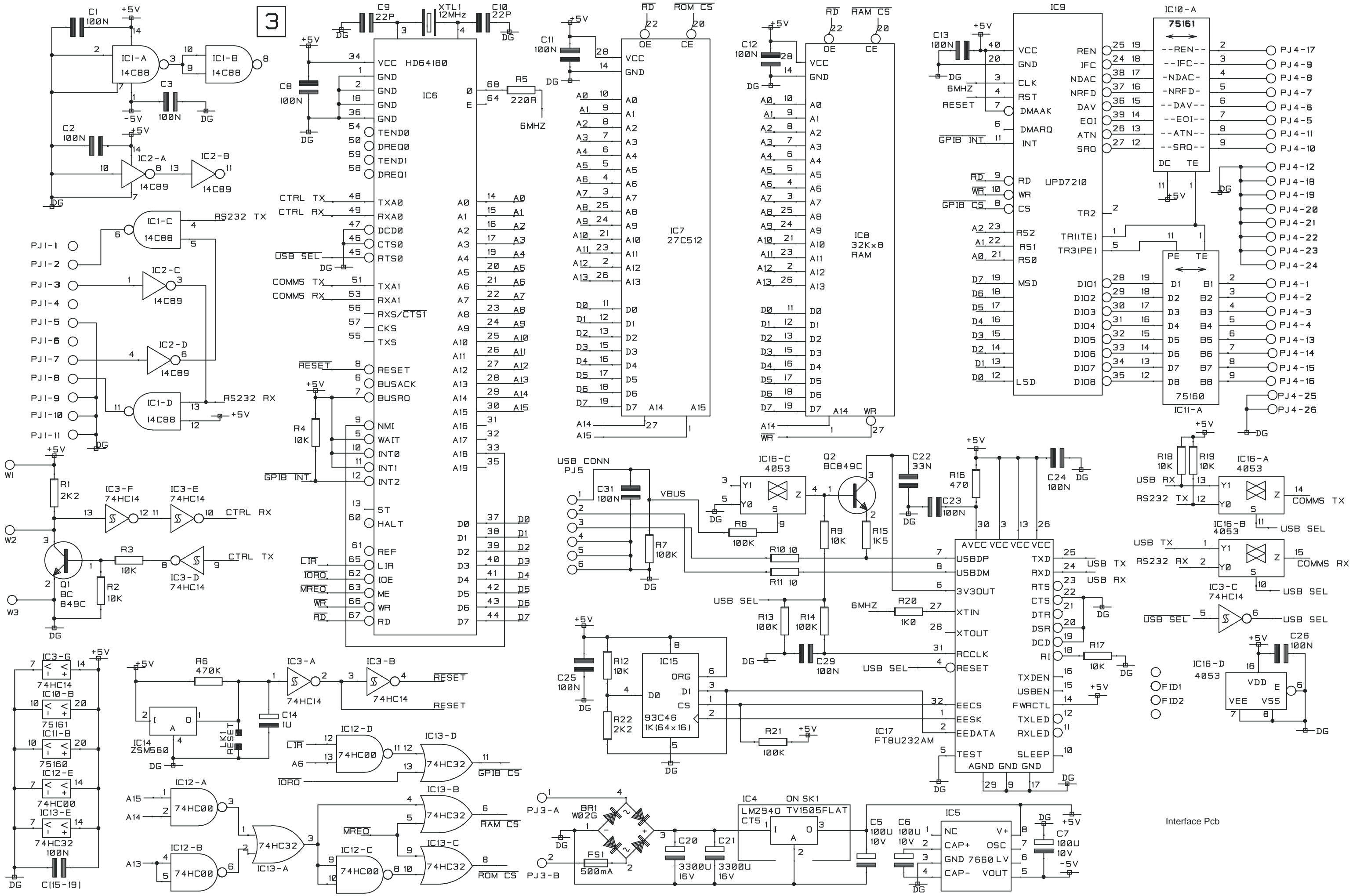

Interface Pcb

2

Auxillary Power - Front panel terminal Pcb (Triple only)

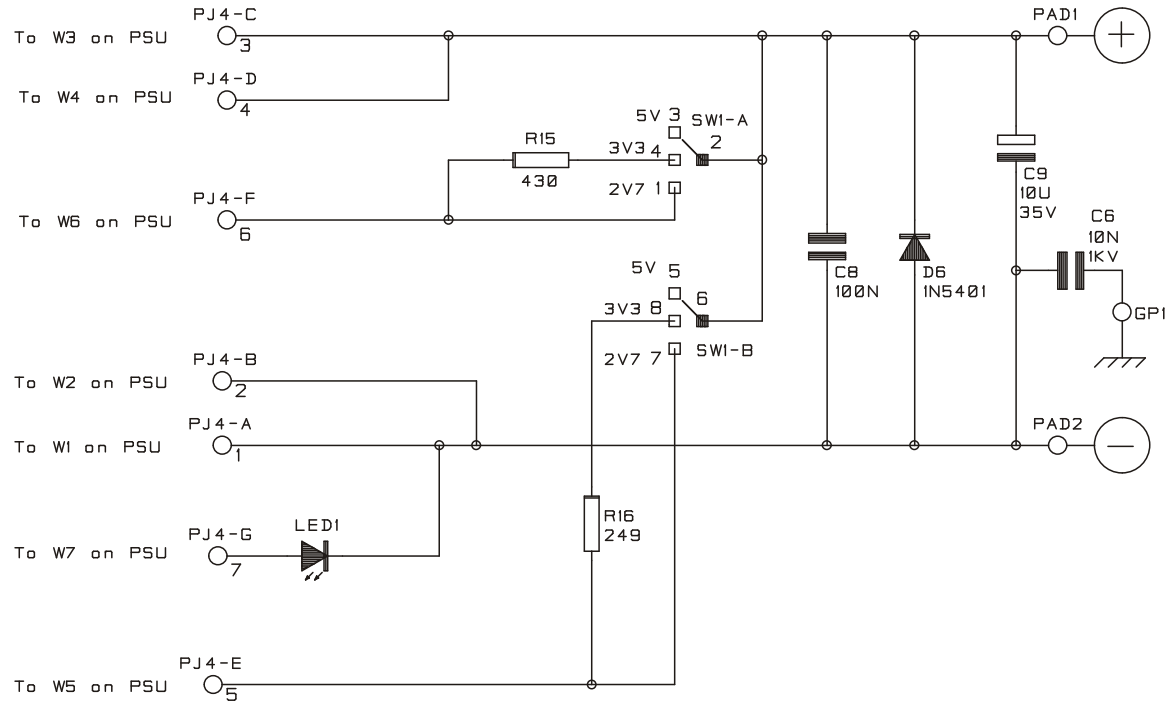

1

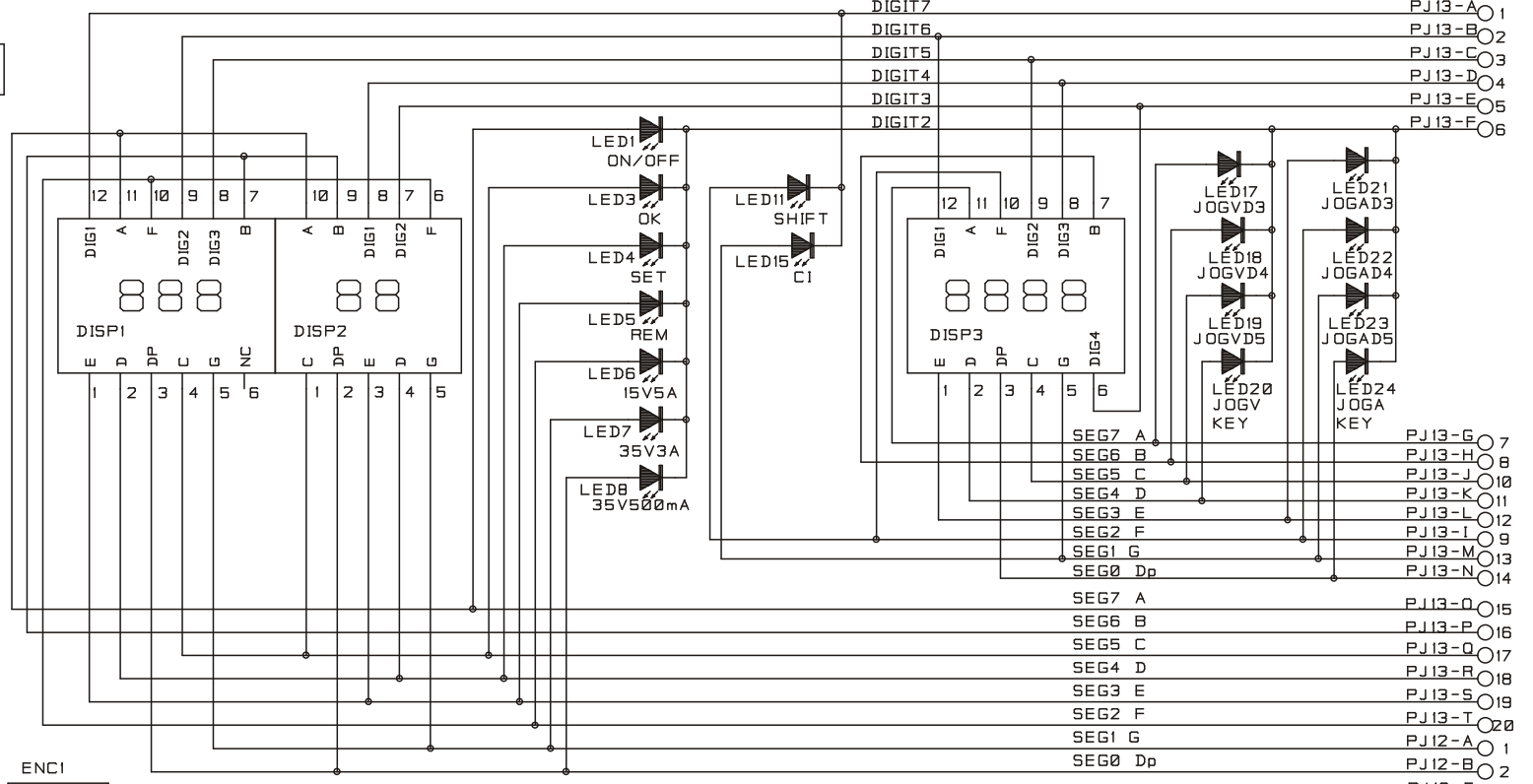

2

Auxillary Power - Power Pcb (Triple only)

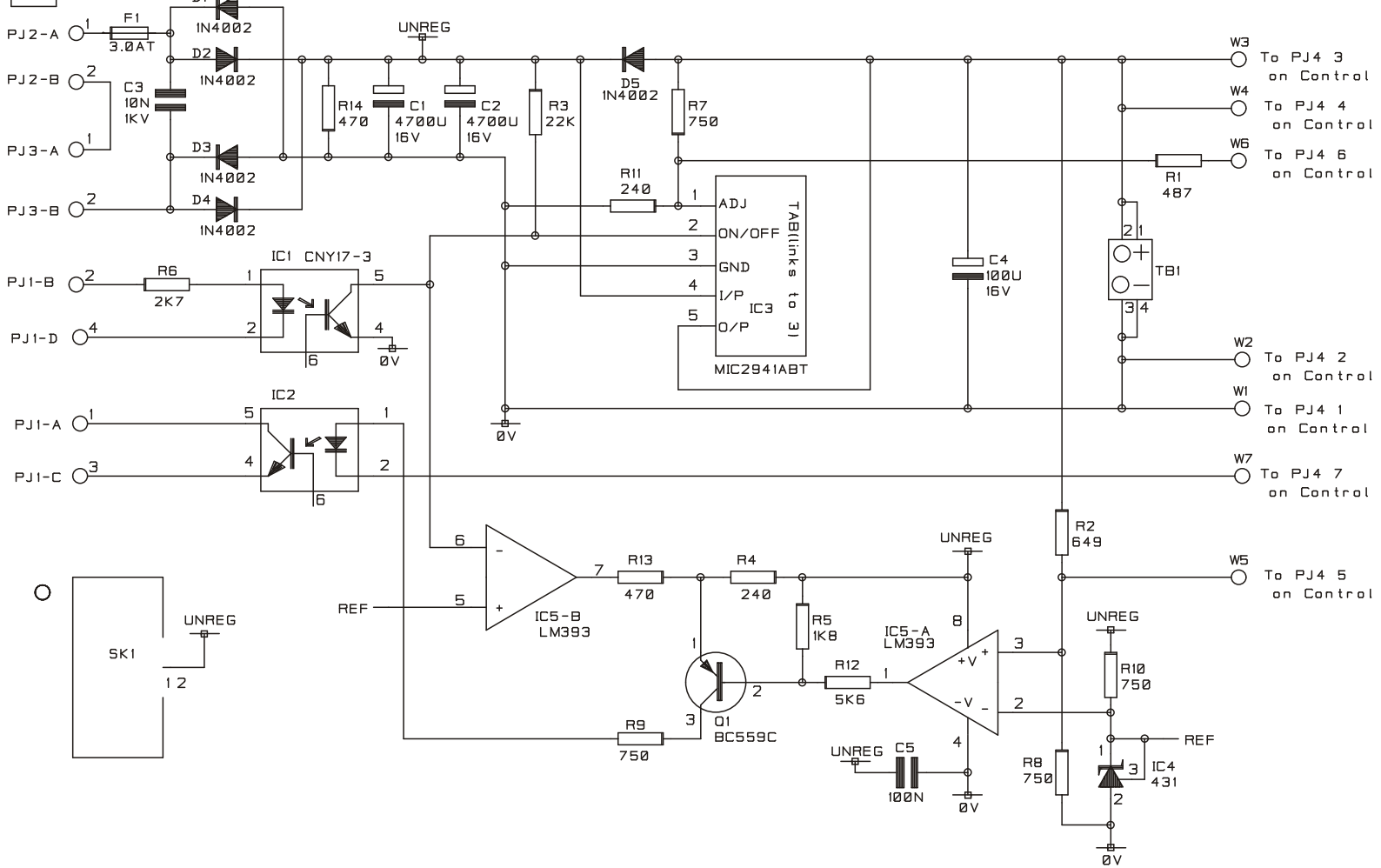

Keyboard & Display Pcb - Single

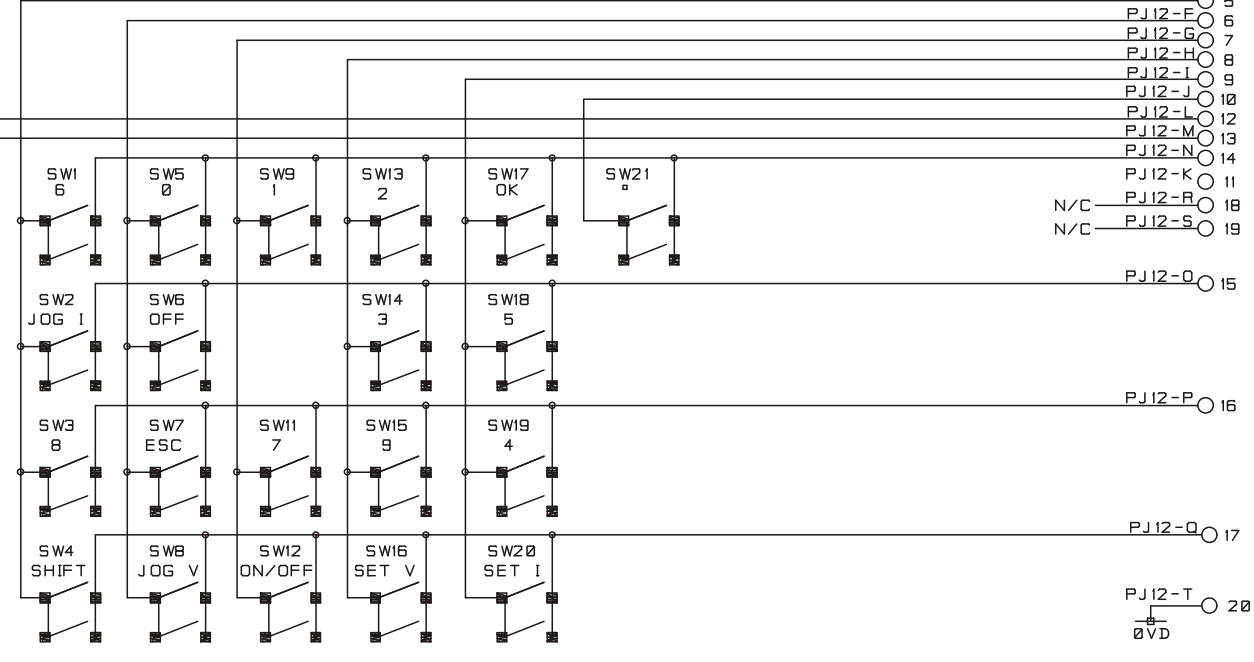

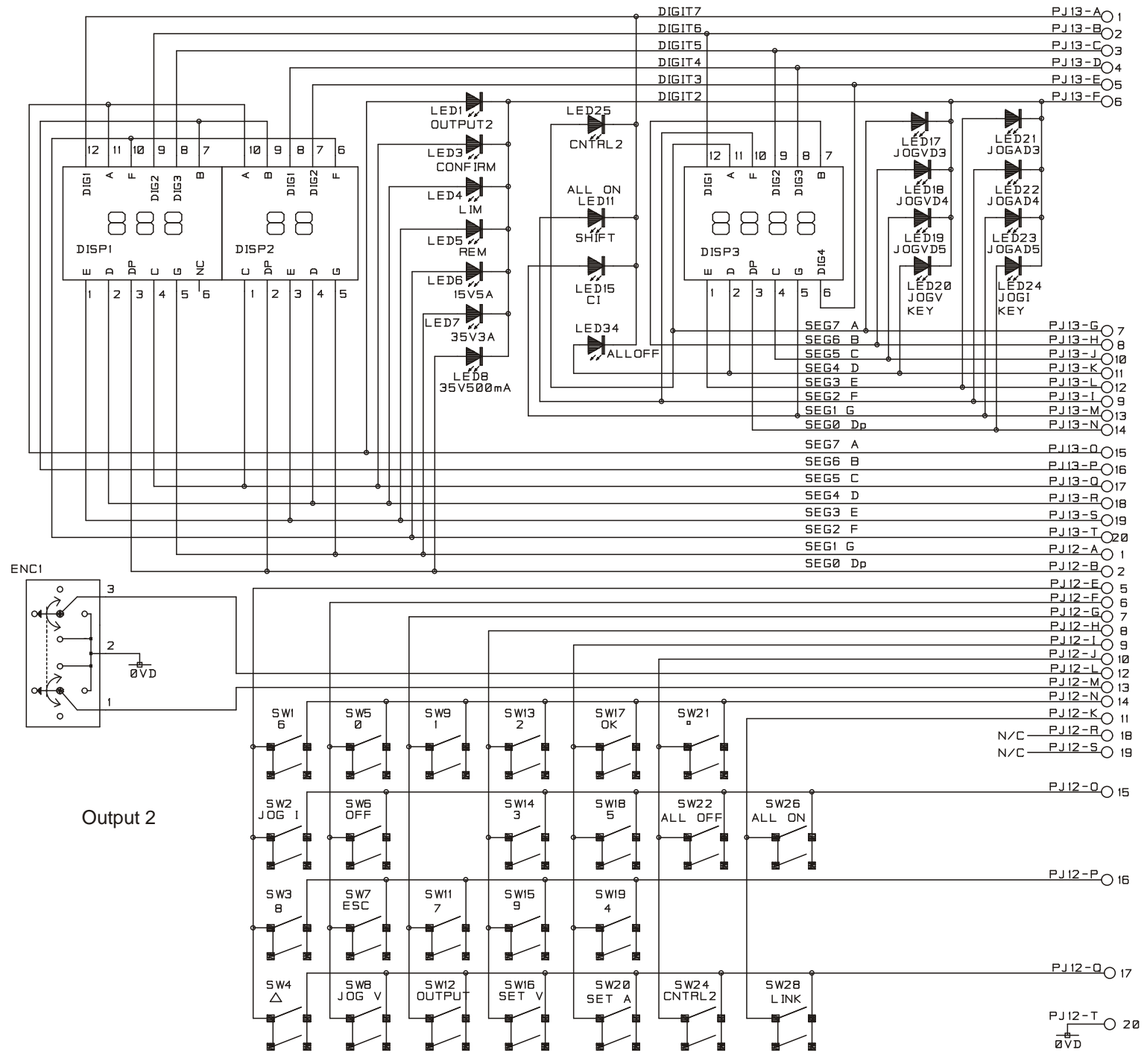
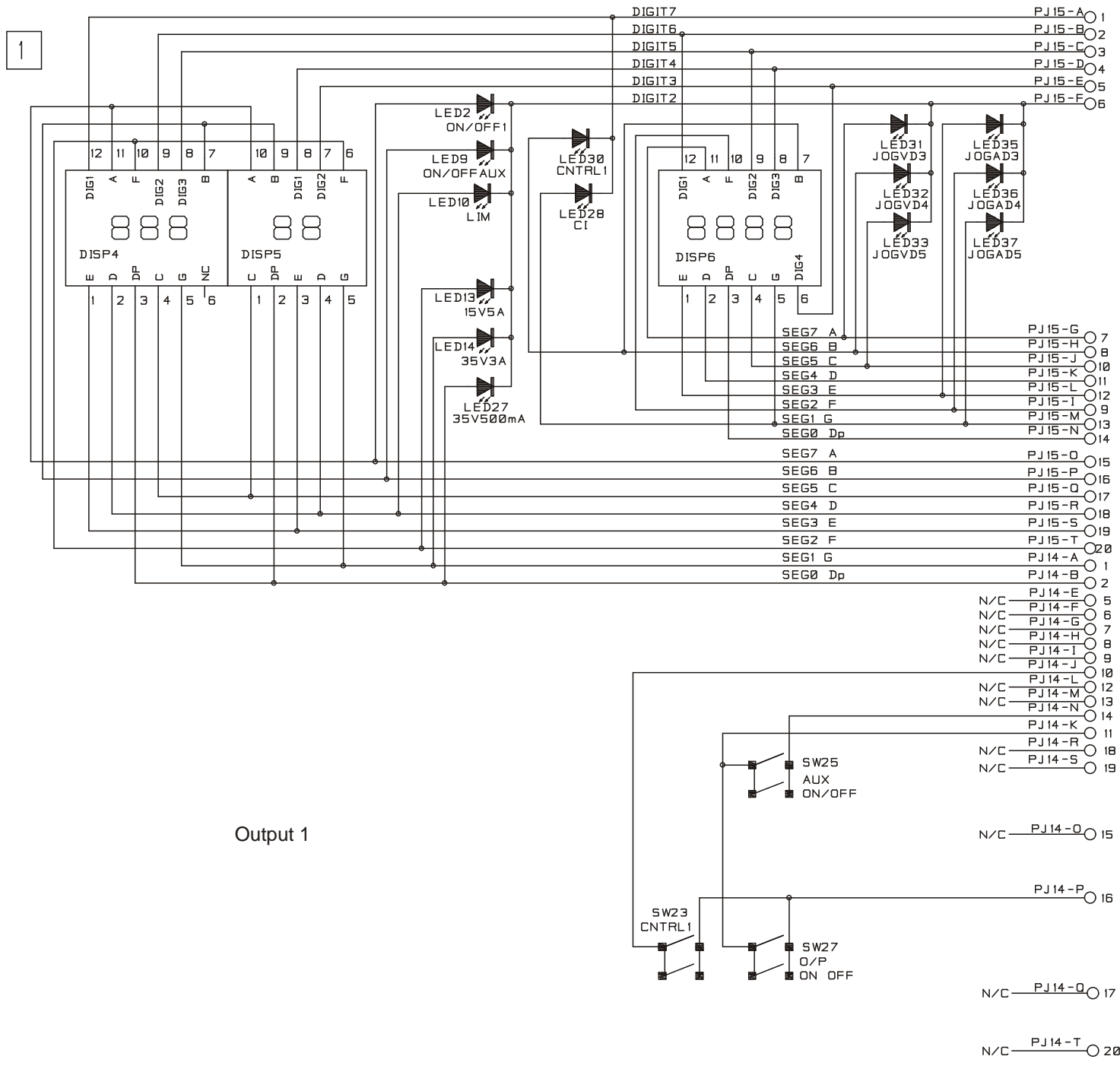

Keyboard & Display Pcb - Triple