

INSTRUCTION MANUAL

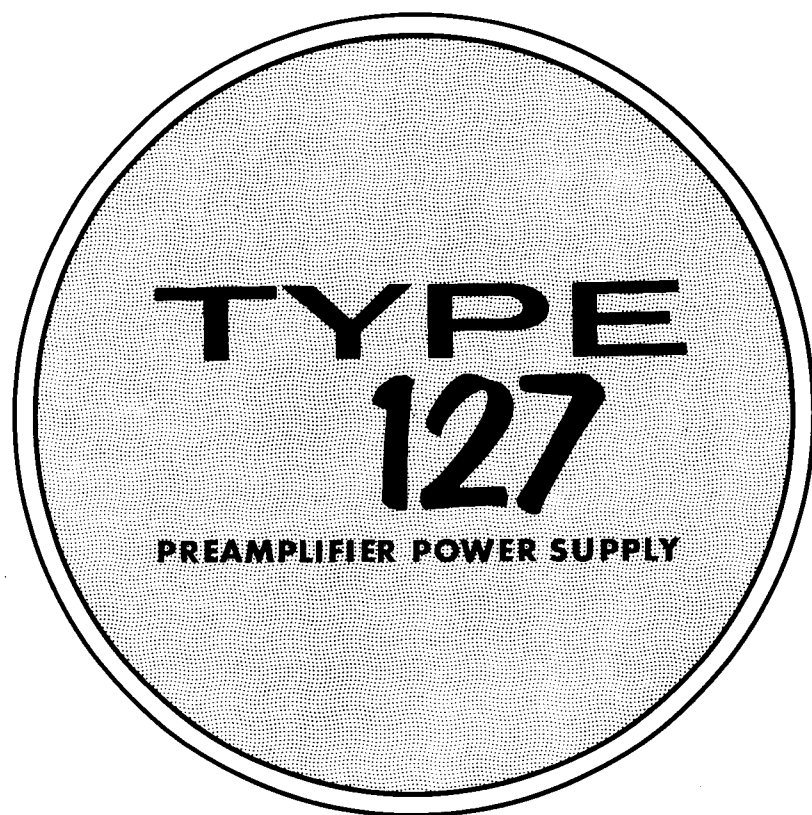

S. W. Millikan Way ● P. O. Box 500 ● Beaverton, Oregon ● Phone MI 4-0161 ● Cables: Tektronix

070-284



WARRANTY

All Tektronix instruments are warranted against defective materials and workmanship for one year. Tektronix transformers, manufactured in our own plant, are warranted for the life of the instrument.

Any questions with respect to the warranty mentioned above should be taken up with your Tektronix Field Engineer.

Tektronix repair and replacement-part service is geared directly to the field, therefore all requests for repairs and replacement parts should be directed to the Tektronix Field Office or Representative in your area. This procedure will assure you the fastest possible service. Please include the instrument Type and Serial number with all requests for parts or service.

Specifications and price change privileges reserved.

Copyright © 1959. New material Copyright © 1961 by Tektronix, Inc., Beaverton, Oregon. Printed in the United States of America. All rights reserved. Contents of this publication may not be reproduced in any form without permission of the copyright owner.



CONTENTS

- Section 1 General Description
- Section 2 Operating Instructions
- Section 3 Circuit Description
- Section 4 Maintenance
- Section 5 Calibration Procedure
- Section 6 Parts List and Schematic Diagrams
- Section 7 Accessories

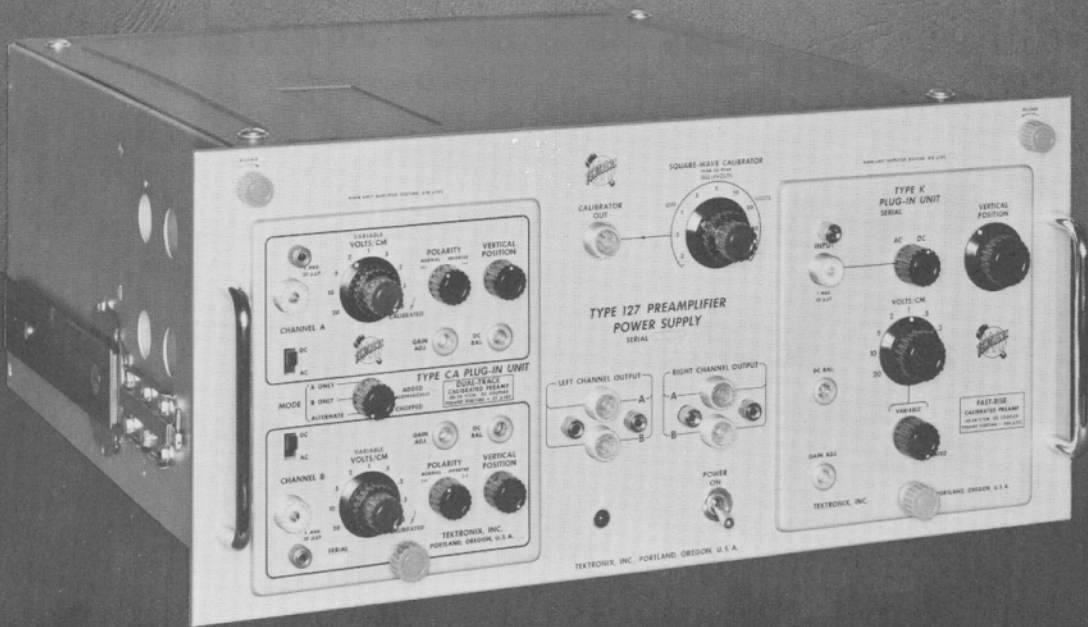

CHANNEL A

VARIABLE VOLTS CM

POLARITY

VERTICAL POSITION

DC

AC

TYPE CA PLUG-IN UNIT

MODE A ONLY

MODE B ONLY

ALTERNATE

ADDED

DUAL INVOICE

TEKTRONIX, INC.

PORTLAND, OREGON, U.S.A.

CHANNEL B

VARIABLE VOLTS CM

POLARITY

VERTICAL POSITION

DC

AC

TEKTRONIX, INC.

PORTLAND, OREGON, U.S.A.

SQUARE-WAVE CALIBRATOR

CALIBRATOR OUT

TYPE 127 PREAMPLIFIER POWER SUPPLY

SERIAL

LEFT CHANNEL OUTPUT

RIGHT CHANNEL OUTPUT

POWER ON

TYPE K PLUG-IN UNIT

SERIAL

AC DC

VOLTS CM

DC BAL

FAST-BISE CALIBRATING RESAMP

TEKTRONIX, INC.

PORTLAND, OREGON, U.S.A.

TEKTRONIX, INC. PORTLAND, OREGON, U.S.A.

SPECIFICATIONS

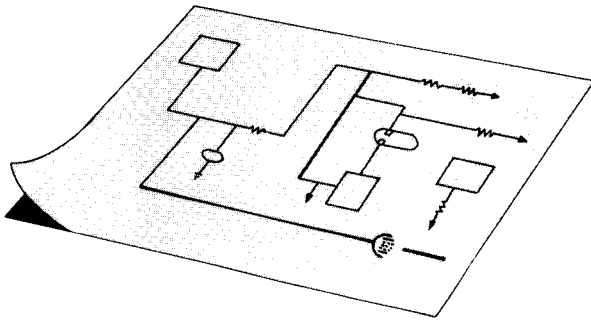

The Type 127 Preamplifier Power Supply is a rack-mounted unit containing a regulated power supply, two direct-coupled output amplifiers, and a square-wave calibrator. It permits the operation of Tektronix plug-in units separate from the oscilloscopes in which they are normally used. The Type 127 may be operated in conjunction with an oscilloscope to obtain increased wide-band sensitivity and multiple-trace displays.

CHARACTERISTICS OF EACH CHANNEL.

	Both sides of push-pull output terminated in 170 ohms.	Both sides of push-pull output terminated in 1 megohm shunted by 50 μmf .
Nominal adjusted gain of the internal amplifier (push-pull output)	1	
Maximum gain of internal amplifier (push-pull output)	1.5	2.5
Passband*	dc to 19 mc	dc to 12 mc
Risetime*	.018 μsec	.035 μsec
Output Impedance		100 ohms
DC output-voltage range	+or- 0 volts**	+or- 10 volts
Peak Signal output voltage	+or- .3 volts**	+or- 3 volts

*With Type K Plug-In Unit.

**The no-signal output voltages must be set at zero to permit an undistorted output signal of +or- .3 volt.

Other Characteristics

Output terminals are provided at both the

front and the back of the chassis to facilitate use of the Type 127 in permanent, rack-mounted equipment.

Rear terminals are provided to permit the introduction of triggering pulses into the Type CA Plug-In Units for utilization of the alternate-sweep feature of these units. The triggering pulse may be obtained from the +GATE OUT terminal on the front panel of the associated oscilloscope.

The 1-kc square-wave calibrator furnishes calibrating signals in the range from .2-millivolt to 100-volts, peak-to-peak. The output waveform has a risetime suitable for use in adjusting the high-frequency compensation of attenuator probes. The accuracy of the calibrator-waveform amplitude is within 3% of the indicated value.

Mechanical Specifications

Construction--Aluminum-alloy chassis. Slide-out mounting to rack.

Finish-Photoetched, anodized panel.

Dimensions--8-3/4" high, 19" wide, 20" rack depth, 21-1/2" overall depth.

Ventilation--Filtered, forced air.

Weight--36 pounds.

Power Requirements--105 to 125 volts or 210 to 250 volts, 50-60 cycles. 450 watts maximum.

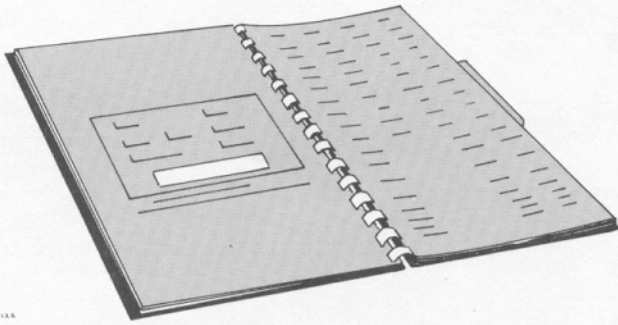

OPERATING INSTRUCTIONS

REQUIREMENTS

Power

Unless tagged otherwise the Type 127 is connected at the factory for 117-volt operation as shown in Fig. 2-1. Transformer connections for 234-volt operation are shown in Fig. 2-2.

The regulated power supplies of the Type 127 will operate with line voltages from 105 to 125 volts, or from 210 to 250 volts. For maximum dependability and long tube life the voltage should be near the center of this range.

The power cord for the Type 127 must be of sufficient length to allow the instrument to rotate freely when it is extended from

the relay rack. Fig. 2-3 shows the dimensions you must consider when providing the power cord.

Cooling

A fan maintains safe operating temperature in the Type 127 by circulating air through a filter and over the rectifiers and other components. The instrument must therefore be placed so that the air intake is not blocked. The air filter must be kept clean to permit adequate air circulation. If the interior temperature does rise too high for some reason, a thermal cutout switch will disconnect the power and keep it disconnected until the temperature drops to a safe value.

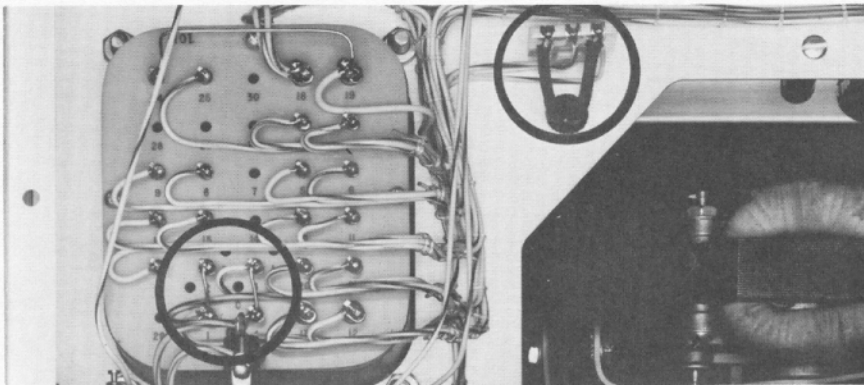

Fig. 2-1. Power-transformer and fan connections for 117-volt operation.

INSTALLATION

Cabinet Rack Mounting

To mount the Type 127 in a cabinet rack:

1. Mark the point on the cabinet rack where you want to position the top of the front panel. Mark a second position 5-3/8 inches below

this point. The center of the top mounting screw should fall on the second mark.

2. Using two 8-32 screws for each bar nut, fasten an 8-32 bar nut to the mounting holes. The top screw will go in the hole found in Step 1, and the bottom screw will go through a

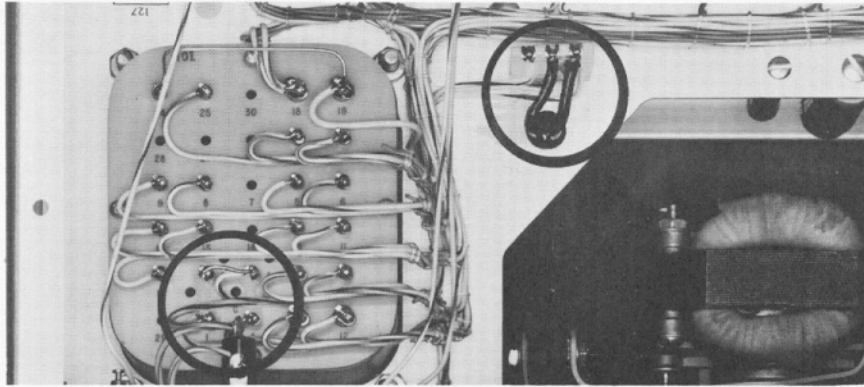

Fig. 2-2. Power-transformer and fan connections for 234-volt operation.

mounting hole approximately 1-3/4 inches below the first.

Note

In some cases it may be necessary to enlarge the mounting holes in the cabinet to provide adequate clearance for the mounting screws.

3. Slip the front lip of the Chassis-Trak between the cabinet and the bar nut as shown in Fig. 2-4a.

4. Tighten the 8-32 screws so that the Chassis-Trak is held securely to the cabinet.

5. In some types of cabinets, you may need the extension brackets furnished with the Chassis-Traks. Fig. 2-4a shows you how to assemble the extension brackets furnished with each set of tracks.

6. Slide the Type 127 into the Chassis-Trak slides. Pull the instrument out and push it back into the cabinet several times. If the

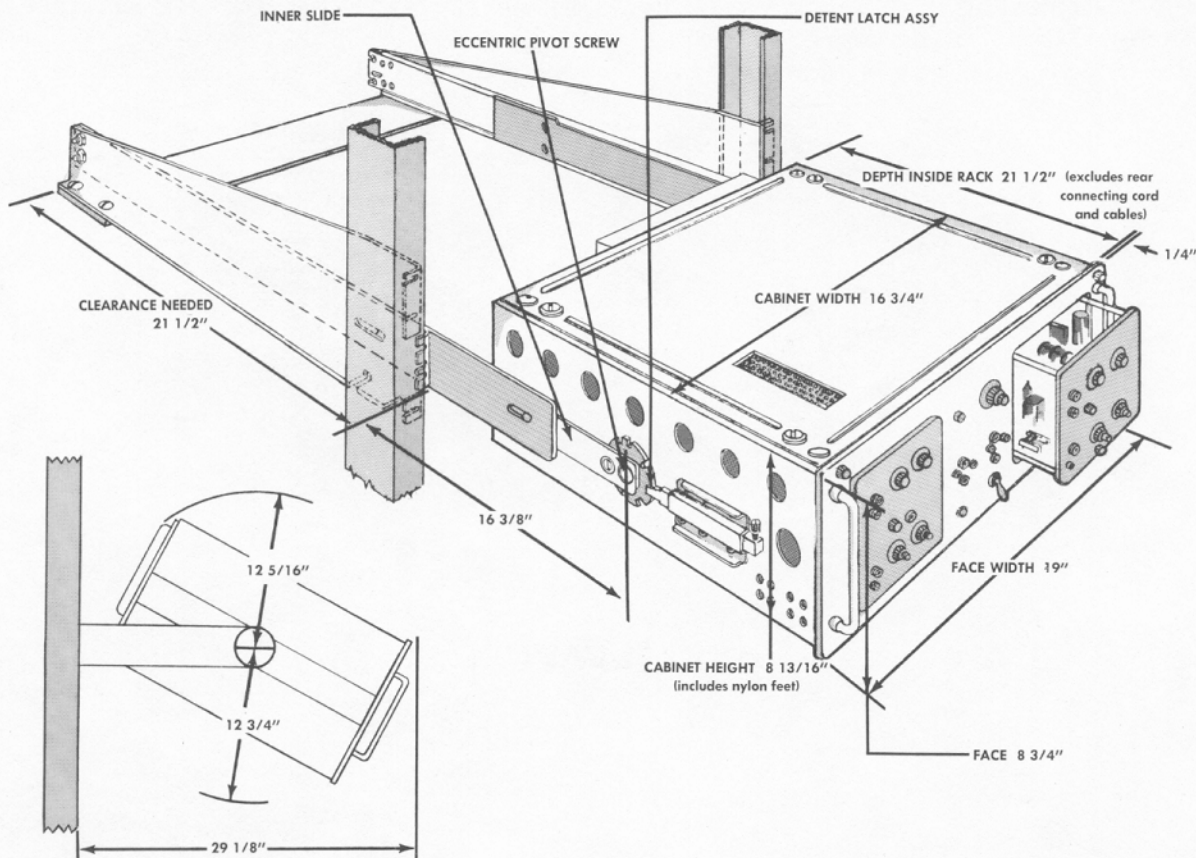

Fig. 2-3. Type 127 mounting dimensions. These dimensions determine the space you must allow for the installation of your 127.

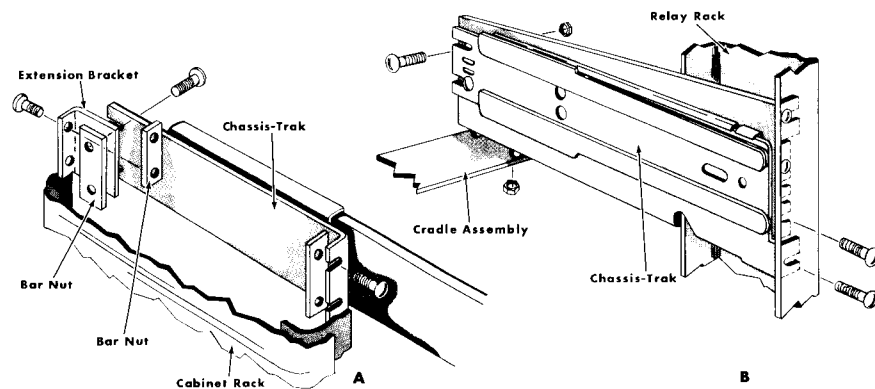

Fig. 2-4. Mounting the Chassis-Trak slides. (A) The Chassis-Trak installed in a cabinet rack. (B) The Chassis-Trak installed in a relay rack.

slide mechanism seems to work stiffly, loosen the mounting screws and allow the Chassis-Traks to adjust to the weight of the instrument. When the slide mechanism is working smoothly, retighten the mounting screws.

7. If the detent latch assemblies and inner slides are not parallel, loosen pivot nuts and adjust eccentric pivot screws for parallel alignment. Retighten pivot nuts.

Relay Rack Mounting

To mount the Type 127 in a relay rack:

1. Bolt the rear of the Chassis-Trak to the rear of the corresponding cradle section using the 8-32 nuts and bolts provided as shown in Fig. 2-4b.

2. Mark a point on the relay rack where you want to position the top of the front panel. Mark a second position 1-7/8 inches below this point. The center of the top mounting screw should fall at this point.

3. Using Fig. 2-3 as a guide, assemble the cradle and Chassis-Trak on the corresponding rails of the relay rack, allowing 1-7/8 inches between the center of the top mounting screw and the position you selected for the top of the 127 front panel.

4. Fasten the brace across the rear of the cradle assembly, making sure that it is mounted in the bottom of the cradle sides.

5. Place the Type 127 in the Chassis-Trak slides as shown in Fig. 2-3. Operate the slide mechanism several times with the instrument installed. If the operation of the slides is not smooth, loosen all of the bolts and allow the slide mechanism to adjust to the weight of the instrument. Be sure to retighten all bolts after the mounting has been adjusted.

6. If the detent latch assemblies and inner slides are not parallel, loosen pivot nuts and adjust eccentric pivot screws for parallel alignment. Retighten pivot nuts.

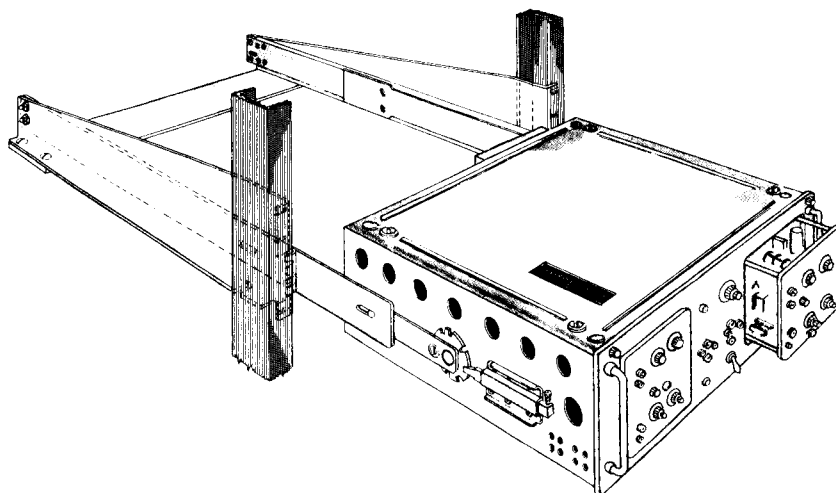

Fig. 2-5. The completed installation. It may be necessary to loosen the bolts and allow the slide mechanism to adjust to the weight of the instrument.

Operation

TABLE 1

Characteristics of the Type 127 in combination with Tektronix plug-in preamplifiers.

Plug-In Unit	Input Characteristics	Maximum Voltage Gain* (push-pull output)	Frequency Response*	Risetime* μ sec
TYPE A	47 μ mf, 1 meg	2	dc to 15 mc	.023
TYPE B	47 μ mf, 1 meg	2 20	dc to 15 mc 2 cps to 11 mc	.023 .030
TYPE C	20 μ mf, 1 meg	2	dc to 17 mc	.020
TYPE D	47 μ mf, 1 meg	100	dc to 350 kc at a gain of 100, increasing to 2 mc at a gain of 2	
TYPE E	50 μ mf, 10 meg	2000	.06 cps to 20 kc at full gain, increasing to 60 kc at a gain of 200.	
TYPE G	47 μ mf, 1 meg	2	dc to 15 mc	.023
TYPE H	47 μ mf, 1 meg	20	dc to 12 mc	.029
TYPE K	20 μ mf, 1 meg	2	dc to 19 mc	.018
TYPE L	20 μ mf, 1 meg	2 20	dc to 19 mc 3 cps to 17 mc	.018 .020
TYPE N	Impedance 50 Ω		to 600 mc	.6 ns
TYPE Q			dc to 6 kc	60
TYPE R				.018
TYPE S				.018
TYPE Z	27 μ mf, 1 meg		dc to 9 mc	.038

*Output terminated in 170 ohms.

Table 1 lists the characteristics of combinations of the Type 127 Preamplifier Power Supply and Tektronix plug-in preamplifiers. The gain of a particular combination for any control setting on the preamplifier (with red knob fully clockwise) can be computed by dividing the number indicated on the VOLTS/CM scale into .1. For example, if the VOLTS/CM

knob is set at 5 and the red variable knob is fully clockwise, the gain is .02 when measured between the output terminals. The outputs must be terminated in 170 ohms for these gain figures to apply. 170-ohm attenuators and terminating resistors are listed in the Accessories section of this manual. When attenuator probes are used with these plug-in

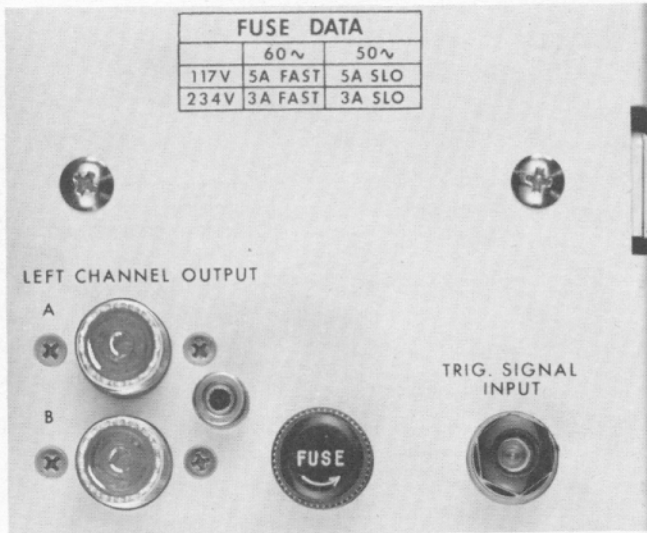

Fig. 2-6. Rear view of Type 127 showing signal connectors and fuse data. When a Type CA Plug-In Unit is used, the switching-multivibrator triggering signal must be connected to the TRIG. SIGNAL INPUT connector. The coaxial connectors are connected in parallel with the corresponding front-panel OUTPUT connectors.

units, the input impedance is raised, but the overall gain of the system is reduced by the attenuation factor marked on the probe body.

The frequency response and risetime figures listed in Table 1 apply only to the combination of the Type 127 and associated plug-in. When the output of the Type 127 is connected to another device, the overall frequency response may be significantly less. If it is necessary that you achieve a specific bandpass in a system using the Type 127, you may wish to compute the overall bandpass before you assemble the equipment. This type of computation is beyond the scope of this manual, however you will find a simplified treatment in the Tektronix publication "A Primer of Waveforms and Their Oscilloscope Displays." Ask your Tektronix Field Engineer for FIP-7581.

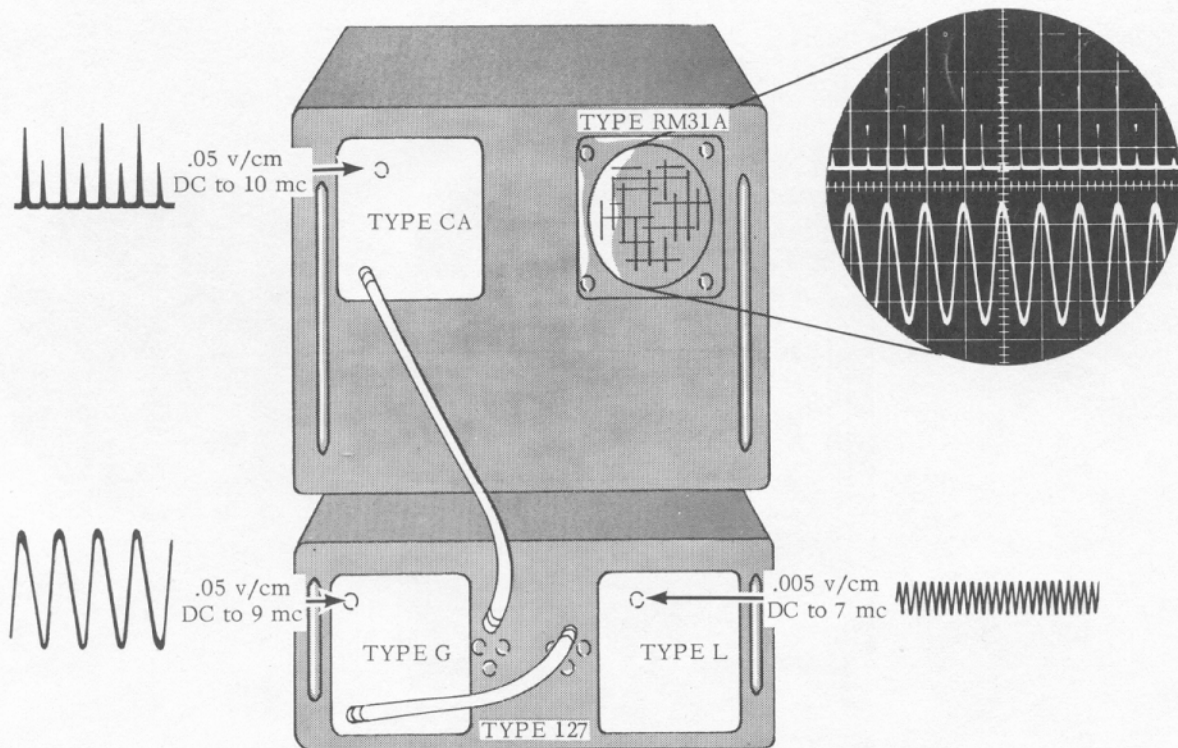

Fig. 2-7. The Type 127 may be used to combine a high-level and a low-level signal differentially for a dual-trace display on the associated oscilloscope.

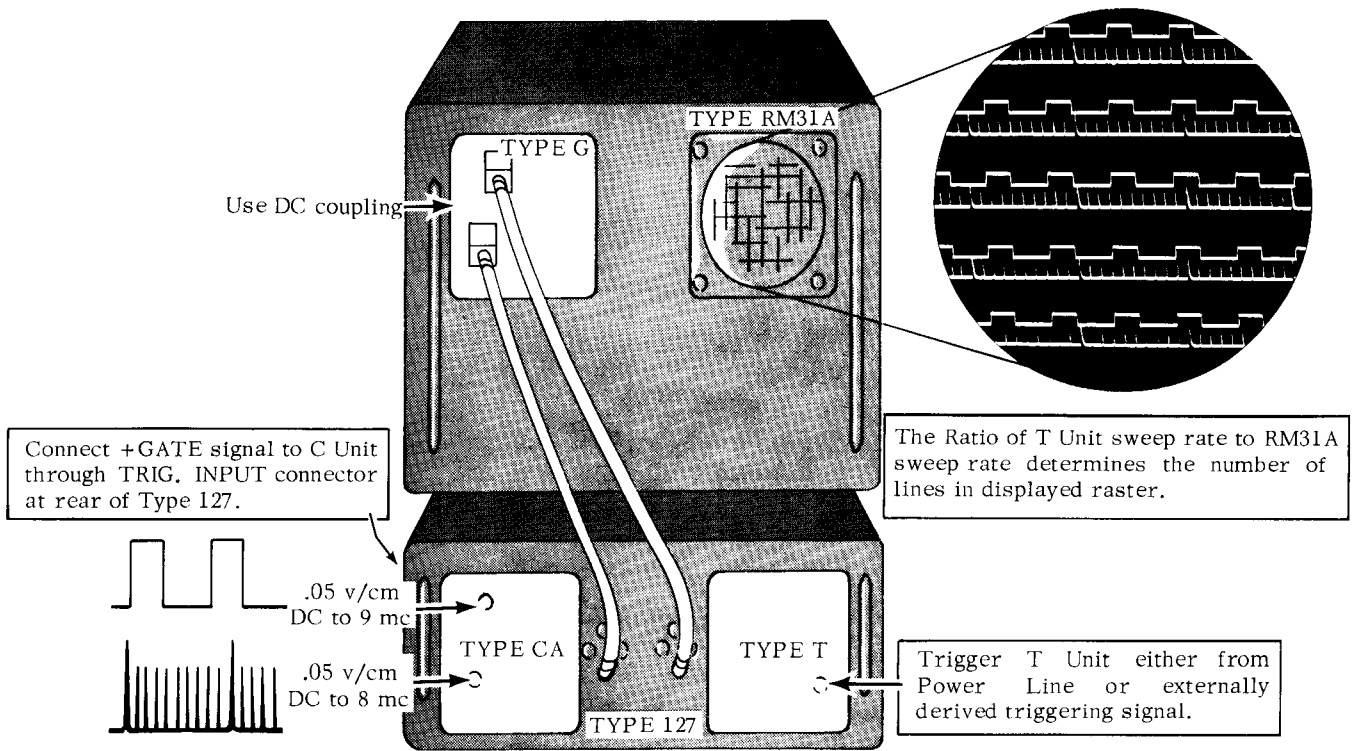

Fig. 2-8. Illustrating the use of the Type 127 to obtain a raster display on the associated oscilloscope.

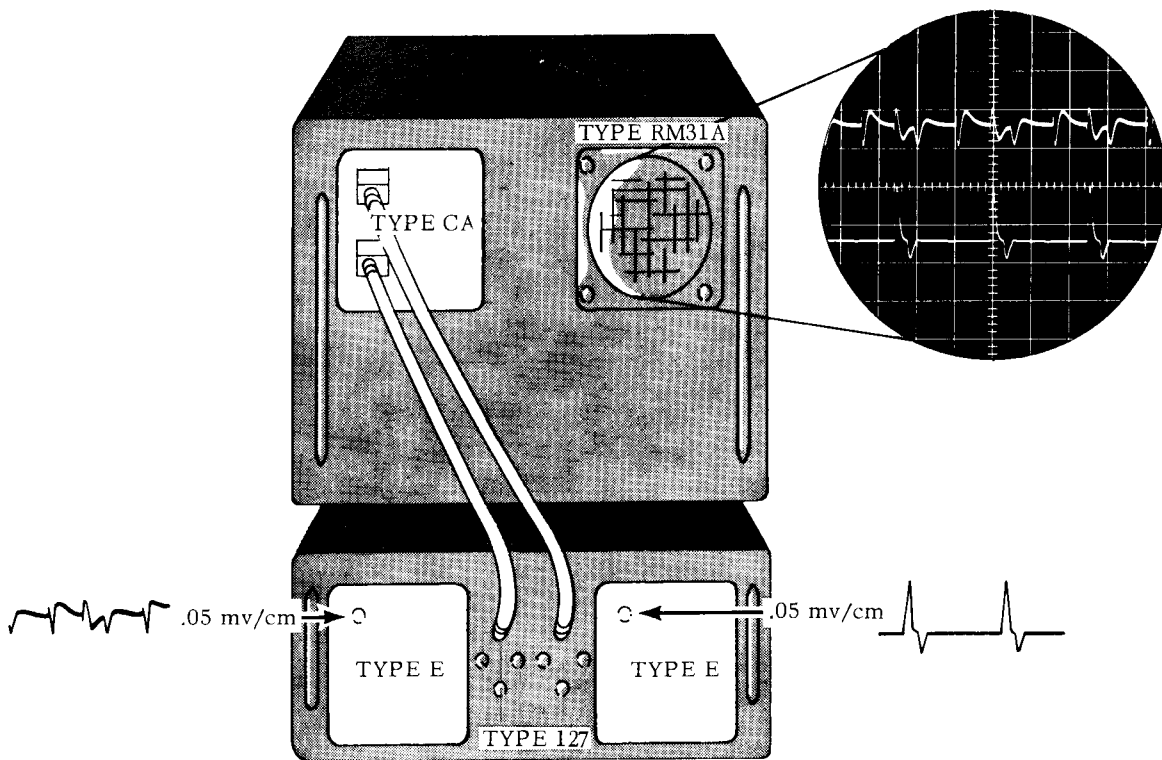

Fig. 2-9. Illustrating the use of a Type 127 with two Type E Units to obtain a dual-trace display of two low-level signals.

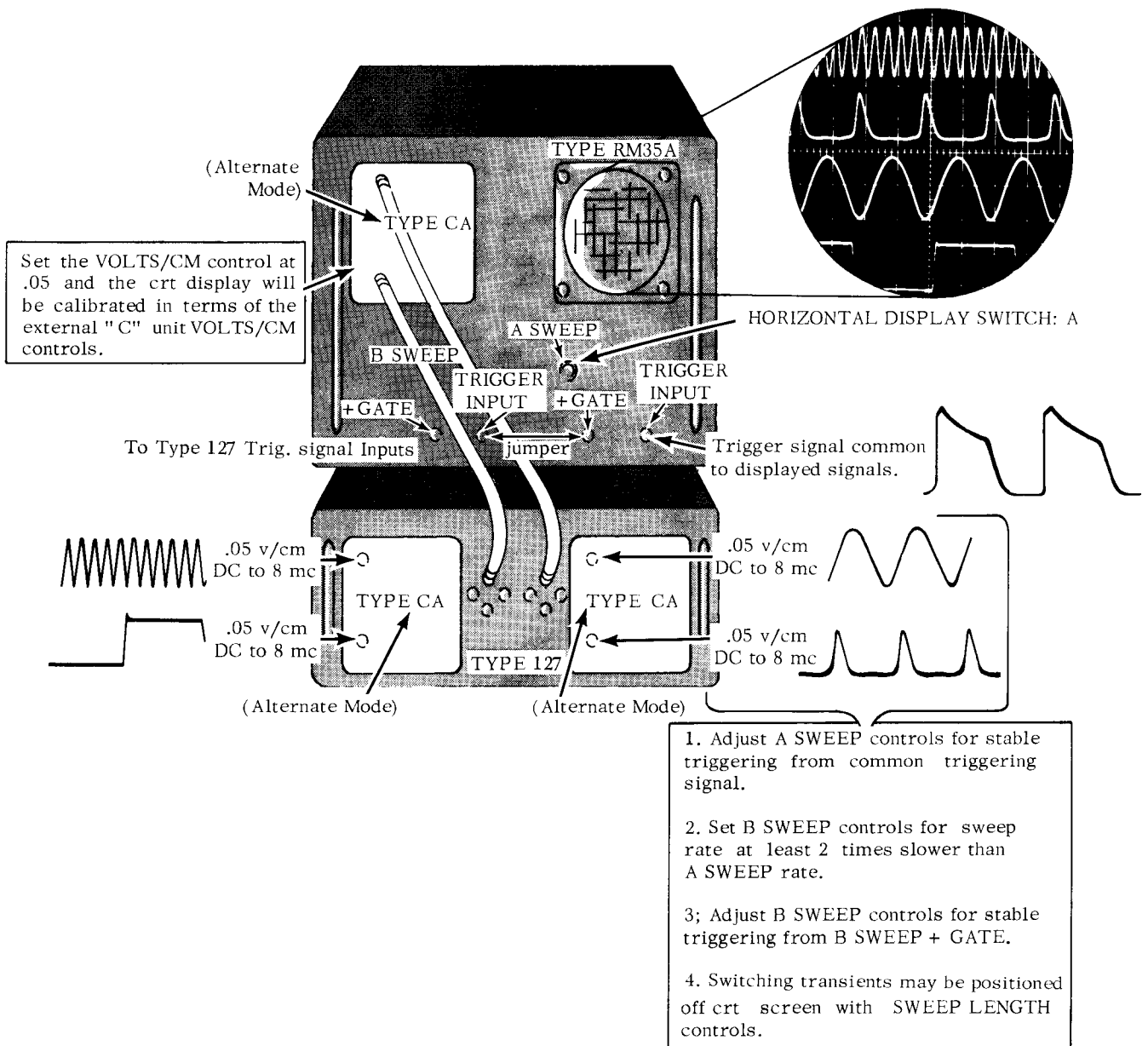
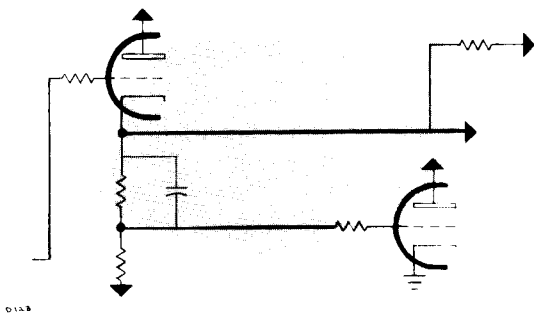

Fig. 2-10. Illustrating the use of the Type 127 in conjunction with two Type CA Units to obtain a display of four waveforms simultaneously.

SECTION 3

CIRCUIT DESCRIPTION



NOTE: Left channel circuit designations are used in the circuit description. However, right channel circuitry is identical except for circuit numbers.

Signal Amplifier

The purpose of the signal amplifier in the Type 127 is to provide a balanced output signal near ground potential, and to provide a low-impedance source from which a coaxial cable may be driven. The overall voltage gain of the amplifier is adjustable to one (push-pull output) when the outputs are terminated in 170 ohms.

The input pentodes operate as a difference amplifier whose gain is varied by changing the resistance between the cathodes (R409). The output of the pentodes is fed into a frequency-compensated voltage divider which attenuates the signal but permits the signal at the output of the cathode followers to appear near ground potential.

Controls R423 and R433 vary the voltage at the grids of the output cathode followers in order to set the dc output level. Changing the setting of these controls does not appreciably change the overall gain of the amplifier.

The network made up of R403 and C403 compensates for slow changes in plate current which occur with large changes in tube conduction (dc shift).

Dual-Trace Switching Circuit

This circuit is in use whenever the alternate-sweep feature of the Type CA Plug-in Unit is used. Operation in this manner requires that a signal from the +GATE OUT connector on the oscilloscope be fed into the TRIG. SIGNAL INPUT binding post on the back of the Type 127.

The gating signal from the oscilloscope is fed into the triode section of V154. In the quiescent state, V154A is cut off, due to the negative voltage drop across R142 and R143.

As the gating waveform begins, V154A starts to conduct heavily and a negative-going spike appears at the control grid of V154B. Since V154B was near cutoff and must conduct heavily to cause the switching to occur, there is no further circuit action. However, on the trailing edge of the input gate, V154A goes to cutoff and its plate voltage rises rapidly. The control grid of V154B receives a large positive-going pulse which drives this tube into heavy conduction, causing the "CA" unit to switch from one channel to the other (see the Type CA instruction manual).

Calibrator

The square-wave calibrating signal is generated by a plate-coupled, astable multivibrator. Its operation is described in detail in most texts on electronic circuitry. For our purposes, it is only necessary to know that V875 is switching between heavy conduction and complete cutoff at a 1 kilocycle rate. When V875 is not conducting, its plate voltage is determined by resistors R878, R882, and the setting of the Cal. Adj. control. This voltage is fed into V873B, of which the cathode circuit is a precision voltage divider. During the time when V875 is conducting heavily, V873B is driven beyond cutoff and its cathode voltage and the voltage at the output of the calibrator fall to zero.

Resistor R898 is used to provide some isolation of the calibrator-output ground terminal from the chassis. This isolation is necessary to prevent the introduction of ac ripple in the output signal when the calibrator output is connected to another instrument by a coaxial cable.

Power Supplies

Regulated Plate Supplies

The voltage-regulated power supplies in the Type 127 are all of the series-regulated type. All the positive supplies use the output voltage of the -150-volt supply for a reference voltage. The -150-volt supply uses a voltage-regulator tube, V629, to supply a stable reference voltage.

The +100-volt supply is a typical series-regulated supply and its action in maintaining a constant output voltage is described in the paragraphs that follow.

This supply uses only two tubes; a voltage amplifier (V644), and a series tube or cathode follower (V657). Resistors R656 and R657 are called sampling resistors because the voltage at this junction is used as a sample of the supply output voltage. The voltage at the junction of these two resistors is near ground potential (slightly negative) when the output voltage of the supply is near 100 volts.

If the -150-volt reference voltage is constant, any change in the output voltage of the power supply will result in a change in the same direction at the junction of the sampling resistors.

The action of the circuit is described by assuming a slight change in the output voltage. Let us assume the output voltage has increased

from +100 volts to +101 volts. The voltage at the junction of R656 and R657 then goes in a positive direction. V644 conducts more heavily since its bias voltage is decreased. The plate voltage on V644 then goes in a negative direction, driving the grids of V657 in a negative direction. Since the input and the output voltages of a cathode follower are in the same phase, the cathode voltage of V657 goes in a negative direction also. The output voltage of the supply then decreases. This decrease in the output voltage almost completely compensates for the increase in the output voltage we assumed at the beginning.

C656 improves the regulation of the supply against AC ripple by providing a larger sample of the AC signal appearing at the output of the supply to the grid of V644.

Regulated Heater Supply

In addition to supplying plate voltage, the +100-volt supply furnishes the regulated voltage to the heaters of the cathode followers in the internal amplifiers and some of the tubes in the plug-in units.

An undercurrent relay connected in series with the regulated heaters operates to keep the load on the +100-volt, +225-volt, and -150-volt supplies relatively constant by loading these supplies with fixed resistances when only one plug-in unit is used.



MAINTENANCE

PREVENTIVE MAINTENANCE

Air Filter

The air filter in the Type 127 is made of aluminum wool coated with an adhesive. When the filter becomes too dirty, the air flow is restricted and the instrument may overheat. The filter should be inspected every three or four months and cleaned or replaced if necessary.

To clean the filter, first remove the loose dirt by rapping the filter gently on a hard surface. Then rinse it with hot water, letting the water flow through the filter from the clean side. If you prefer, wash the filter in warm, soapy water before rinsing. Then let it dry thoroughly. The dry filter should be coated with "Handi-Koter" or "Filtercoat", made by the Research Products Corporation and sold by air-conditioning equipment suppliers.

Fan Motor

The bearings in the fan motor should be oiled every three to four months. Use a good grade of light machine oil and apply only a drop or two.

Soldering and Ceramic Strips

Many of the components in your Tektronix instrument are mounted on ceramic terminal strips. The notches in these strips are lined with a silver alloy. Repeated use of excessive heat, or use of ordinary tin-lead solder will break down the silver-to-ceramic bond. Occasional use of tin-lead solder will not break the bond if excessive heat is not applied.

If you are responsible for the maintenance of a large number of Tektronix instruments, or if you contemplate frequent parts changes,

we recommend that you keep on hand a stock of solder containing about 3% silver. This type of solder is used frequently in printed circuitry and should be readily available from radio-supply houses. If you prefer, you can order the solder directly from Tektronix in one-pound rolls. Order by Tektronix part number 251-514.

Because of the shape of the terminals on the ceramic strips it is advisable to use a wedge-shaped tip on your soldering iron when you are installing or removing parts from the strips. Fig. 4-1 will show you the correct shape for the tip of the soldering iron. Be sure and file smooth all surfaces of the iron which will be tinned. This prevents solder from building up on rough spots where it will quickly oxidize.

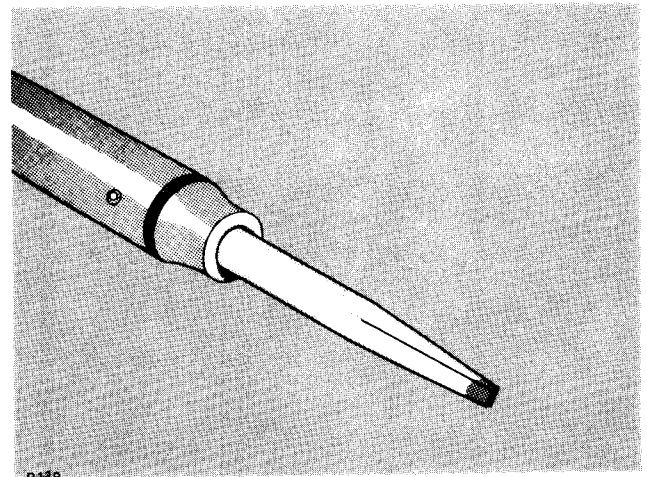

Fig. 4-1. Soldering iron tip properly shaped and tinned.

When removing or replacing components mounted on the ceramic strips you will find that satisfactory results are obtained if you proceed in the manner outlined below.

1. Use a soldering iron of about 75-watt rating.
2. Prepare the tip of the iron as shown in Fig. 4-1.
3. Tin only the first 1/16 to 1/8 inch of the tip. For soldering to ceramic terminal strips tin the iron with solder containing about 3% silver.
4. Apply one corner of the tip to the notch where you wish to solder (see Fig. 4-2).

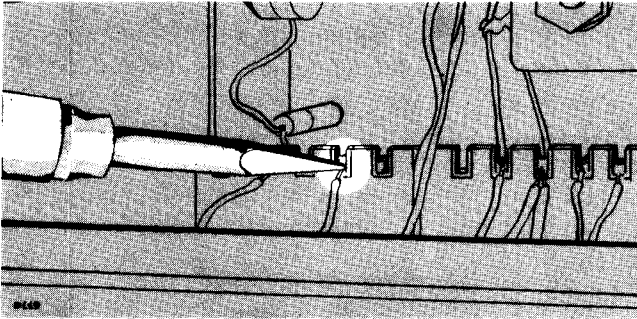

Fig. 4-2. Correct method of applying heat in soldering to a ceramic strip.

5. Apply only enough heat to make the solder flow freely.
6. Do not attempt to fill the notch on the strip with solder; instead, apply only enough solder to cover the wires adequately, and to form a slight fillet on the wire as shown in Fig. 4-3.

In soldering to metal terminals (for example, pins on a tube socket) a slightly different technique should be employed. Prepare the

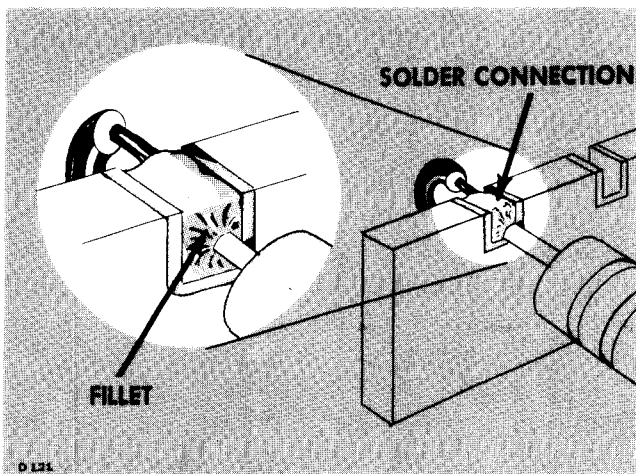

Fig. 4-3. A slight fillet of solder is formed around the wire when heat is applied correctly.

iron as outlined above, but tin with ordinary tin-lead solder. Apply the iron to the part to be soldered as shown in Fig. 4-4. Use only enough heat to allow the solder to flow freely along the wire so that a slight fillet will be formed as shown in Fig. 4-3.

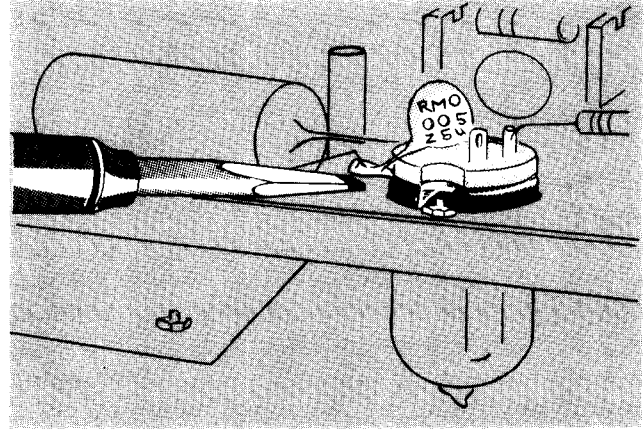

Fig. 4-4. Soldering to a terminal. Note the slight fillet of solder--exaggerated for clarity--formed around the wire.

General Soldering Considerations

When replacing wires in terminal slots clip the ends neatly as close to the solder joint as possible. In clipping ends of wires take care the end removed does not fly across the room as it is clipped.

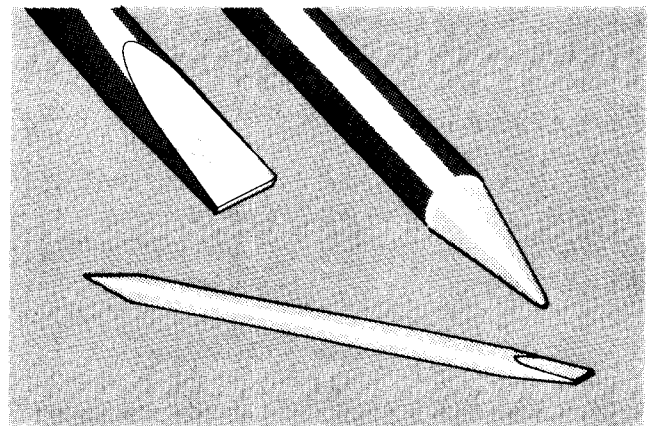

Fig. 4-5. A soldering aid constructed from a 1/4 inch wooden dowel.

Occasionally you will wish to hold a bare wire in place as it is being soldered. A handy device for this purpose is a short length of wooden dowel, with one end shaped as shown in Fig. 4-5. In soldering to terminal pins mounted in plastic rods it is necessary to use some form of "heat sink" to avoid melt-

ing the plastic. A pair of long-nosed pliers (see Fig. 4-6) makes a convenient tool for this purpose.

Ceramic Strips

Two distinct types of ceramic strips have been used in Tektronix instruments. The earlier type mounted on the chassis by means of #2-56 bolts and nuts. The later type is mounted with snap-in, plastic fittings. Both styles are shown in Fig. 4-7.

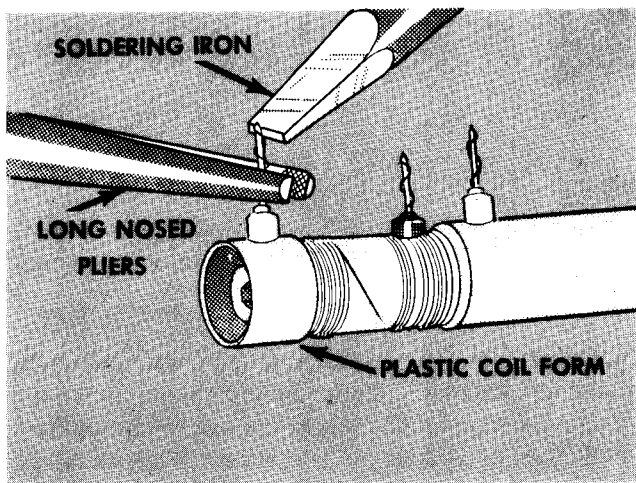

Fig. 4-6. Soldering to a terminal mounted in plastic. Note the use of the long-nosed pliers between the iron and coil form to absorb the heat.

To replace ceramic strips which bolt to the chassis, screw a #2-56 nut onto each mounting bolt, positioning the bolt so that the distance between the bottom of the bolt and the bottom of the ceramic strip equals the height at which you wish to mount the strip above the chassis. Secure the nuts to the bolts with a drop of red glyptal. Insert the bolts through the holes in the chassis where the original strip was mounted, placing a #2 starwasher between each nut and the chassis. Place a second set of #2 flatwashers on the protruding ends of the bolts, and fasten them firmly with another set of #2-56 nuts. Place a drop of

red glyptal over each of the second set of nuts after fastening.

Mounting Later Ceramic Strips

To replace strips which mount with snap-in plastic fittings, first remove the original fittings from the chassis. Assemble the mounting post on the ceramic strip. Insert the nylon collar into the mounting holes in the chassis. Carefully force the mounting post into the nylon collars. Snip off the portion of the mounting post which protrudes below the nylon collar on the reverse side of the chassis.

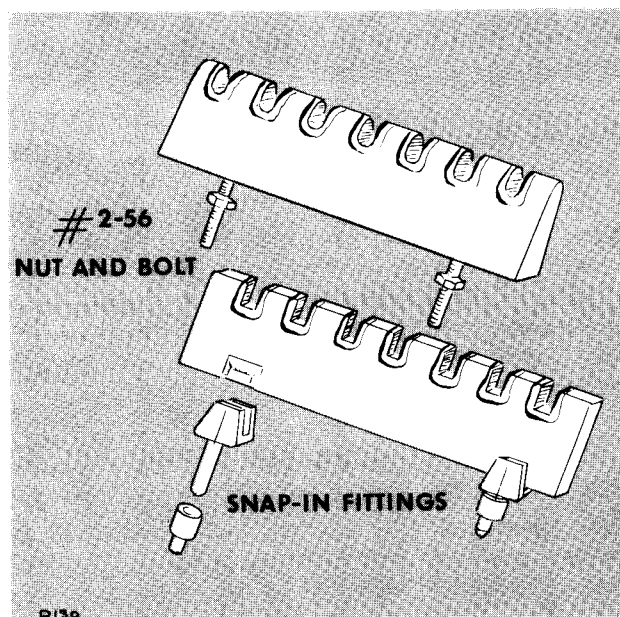

Fig. 4-7. Two types of ceramic strip mountings.

Note

Considerable force may be necessary to push the mounting rods into the nylon collars. Be sure that you apply this force to that area of the ceramic strip directly above the mounting rods.

TROUBLESHOOTING

General

Most of the troubles that you may encounter in the Type 127 will be due to tube failure. Sometimes a tube failure results in damage to resistors or inductors. These faulty components may go unnoticed and then fail at

an inopportune time. Therefore, it is a good policy to inspect for overheated parts in the vicinity of a tube that has failed.

When you replace a tube in a critical circuit, such as the voltage amplifier in a regulated power supply or the input stage of the wide-

band amplifier, make a quick check to see that everything is operating properly. Sometimes new tubes do not perform well in circuits where low hum level, microphonism, etc. are important. Some new tubes also do not have the transconductance required to realize the 19-mc pass-band of which the amplifier is capable. Frequently a tube tester does not indicate these necessary characteristics, so the best test method is to try new tubes or tubes known to be good until you get the circuit performance you desire.

Some troubles that you may encounter will be in the plug-in unit rather than in the Type 127, so try a different plug-in unit before beginning the troubleshooting procedure which follows.

Power Supplies

Before making voltage measurements in the power supply that you believe to be at fault, check the output voltage of the other power supplies, since the cause of the trouble may be common to all of them. Remember that the output voltage of the -150-volt supply affects the output voltage of all supplies.

Next, compare your reading of the unregulated voltage at the plates of the series tube with that shown at the corresponding point on the diagram. When you make this check, be sure that the input voltage to the instrument is 117 volts RMS (or 234 volts RMS), to take any deviation in line voltage into account when you evaluate your reading. The reading will also vary somewhat with different plug-in units.

If the output voltage of the supply is high or low and the output ripple is considerably greater than 20 millivolts peak-to-peak, the trouble may be in the voltage regulator circuit or in the output circuit load.

If the output voltage of the supply is only a few volts high or low and the ripple is less than about 20 millivolts peak-to-peak, it is likely that the voltage-sampling resistors are out of tolerance.

Internal Amplifier

The procedure that follows assumes that the power supply voltages are all correct and that

the tubes in the internal amplifier are known to be good. Defective components are localized in this procedure by checking the voltage at key points in the circuit under specified conditions. Part numbers are given for the amplifier on the left side of the instrument, but the procedure is identical for the right side. A plug-in unit must be in place in the appropriate receptacle.

A VTVM was used to make the voltage measurements given below. A 20,000 ohms-per-volt meter may be used if an anti-oscillation resistor of about 1000 ohms is connected in series with the probe end of the positive lead.

1. Short pins 1 and 3 interconnecting socket.
2. Measure the voltage at pins 1 and 3 of the interconnecting socket. This voltage is normally between 66 and 70 volts.
3. Measure the voltage at the plates of the input amplifiers. If the voltage is considerably different from +210 volts, measure the voltages at other elements of the tube. If they appear to be normal, turn off the unit and measure each of the resistances in the plate and cathode circuits of the input tubes.
4. Measure the output voltage range of each channel by rotating the appropriate DC Level Output control (internal). The normal range is from about +10 to -10 volts when the outputs are unterminated. If the voltage range you measure does not include zero volts, measure the resistance of each of the current-carrying resistors in the grid circuit of the output cathode followers. The precision resistors may be damaged by a scratch, so be especially careful when you disconnect them for measurement. Check the cathode resistors of the output cathode followers.
5. Remove the shorting wire from the interconnecting socket.
6. To check for the cause of poor frequency response after steps 1 to 5 have been completed, go through the calibration procedure of the internal amplifier.

CALIBRATION PROCEDURE

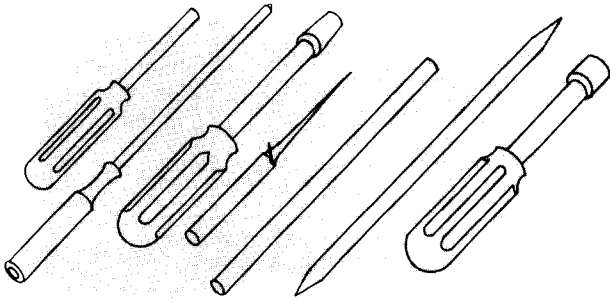

General

At least one plug-in unit known to be in operating condition must be in place in the Type 127 for the calibration of the power supply and the calibrator. Inputs to the plug-in unit should be grounded or the cables to the inputs should be disconnected.

Power Supply

1. Connect an accurate voltmeter set to read -150 volts between the -150-volt line and the chassis.
2. Adjust R637 (-150 Adj.) so that the meter reads -150 volts.
3. Check each of the other regulated voltages including the decoupled voltages. These voltages should be within 5% of the nominal value.
4. Check the ripple on each regulated supply output (not decoupled). The peak-to-peak ripple on the -150-volt supply should not exceed 5 mv, and the ripple on the other supplies should not exceed 10 mv.

Calibrator

1. Turn the red CALIBRATOR knob to OFF.
2. Connect an accurate voltmeter set to read 100 volts DC to the internal pin jack marked Cal. Test Pt. The meter should have a sensitivity of at least 20,000 ohms per volt.
3. Adjust R879 (Cal. Adj.) so that the meter reads 100 volts.

Internal Amplifier

The complete calibration of the internal amplifier requires a properly adjusted plug-in unit with a risetime of no longer than .015

μ sec and a square-wave generator with a risetime of no longer than .015 μ sec. Both outputs of the channel under test must be terminated in 170 ohms.

The procedure that follows applies to both amplifiers incorporated in the Type 127, although part numbers for only the left side are given.

1. Setting the DC Output Level

Connect pins 1 and 3 of the interconnecting socket together. Connect a dc voltmeter between the upper output terminal on the front panel and ground. Adjust DC Level Output A (R433) for a voltage reading of zero. Next, connect the voltmeter between the lower output terminal and ground and adjust DC Level Output B (R423) for a voltage reading of zero. Remove the shorting wire on the interconnecting socket.

2. Adjusting the Gain

Set the V/CM control on the plug-in unit to .05. Feed a 100 millivolt peak-to-peak square wave from the calibrator into the input of the plug-in unit. Connect the oscilloscope to either the upper or lower output connector and adjust the Gain Adj. control in the Type 127 for a vertical deflection of 2 cm.

3. Adjusting the Frequency Response

Insert a Tektronix Type A, B, C, G, H, K, or L Plug-In Unit into the left receptacle. Set the VOLTS/CM control to .05 and turn the red VARIABLE knob fully clockwise. The input selector may be set to either AC or DC. Connect the output of the square-wave generator to the input of the plug-in unit through a coaxial cable terminated in its characteristic impedance.

Connect the lower output terminal of the Type 127 to the oscilloscope by a length of 170-ohm coaxial cable terminated in 170 ohms. Adjust the output voltage of the square-wave generator to produce a peak-to-peak signal of about .2 volt at the lower output terminal of the Type 127. Adjust C421 for best square-wave response. Increase the sweep speed of the oscilloscope and the frequency of the square-

wave generator to spread out the leading edge of the square-wave display. Then adjust L404 and L405 for minimum risetime without appreciable overshoot.

Make corresponding adjustments of C431, L414, and L415 when the oscilloscope is connected to the upper output terminal.

PARTS LIST *and*

DIAGRAMS

Part No.	Description	Quantity	Notes
281-001
281-002
281-003
281-004
281-005
281-006
281-007
281-008
281-009
281-010
281-011
281-012
281-013
281-014
281-015
281-016
281-017
281-018
281-019
281-020
281-021
281-022
281-023
281-024
281-025
281-026
281-027
281-028
281-029
281-030
281-031
281-032
281-033
281-034
281-035
281-036
281-037
281-038
281-039
281-040
281-041
281-042
281-043
281-044
281-045
281-046
281-047
281-048
281-049
281-050
281-051
281-052
281-053
281-054
281-055
281-056
281-057
281-058
281-059
281-060
281-061
281-062
281-063
281-064
281-065
281-066
281-067
281-068
281-069
281-070
281-071
281-072
281-073
281-074
281-075
281-076
281-077
281-078
281-079
281-080
281-081
281-082
281-083
281-084
281-085
281-086
281-087
281-088
281-089
281-090
281-091
281-092
281-093
281-094
281-095
281-096
281-097
281-098
281-099
281-100

Cer.
Comp.
EMC
f
G
GMV
h
K or k
M/Cer.
M or meg
 μ
 $\mu\mu$
m

Ceramic
Composition
Electrolytic, metal cased
Farad
Giga, or 10^9
Guaranteed minimum value
Henry
Kilohms or kilo (10^3)
Mica or Ceramic
Megahms or mega (10^6)
Micro, or 10^{-6}
Micromicro or 10^{-12}
milli or 10^{-3}

ABBREVIATIONS

n
 Ω
p
PTB
PMC
Poly.
Prec.
PT
T
v
Var.
w
WW
Nano or 10^{-9}
ohm
Pico or 10^{-12}
Paper, "Bathtub"
Paper, metal cased
Polystyrene
Precision
Paper Tubular
Terra or 10^{12}
Working volts DC
Variable
Watt
Wire-wound

SPECIAL NOTES AND SYMBOLS

+ and up
† Approximate serial number.
X000 Part first added at this serial number.
000X Part removed after this serial number.
*000-000 Asterisk preceding Tektronix Part Number indicates manufactured by or for Tektronix, also reworked or checked components.
(Mod. w/) Simple replacement not recommended.
Modify to value for later instruments and change other parts to match.



MANUFACTURERS OF CATHODE-RAY OSCILLOSCOPES

TYPE 127

Mod. 5284 Tent SN 1220

C421	change to	3-12 $\mu\mu$ f	Cer	Var	281-007
C431	change to	3-12 $\mu\mu$ f	Cer	Var	281-007
C521	change to	3-12 $\mu\mu$ f	Cer	Var	281-007
C531	change to	3-12 $\mu\mu$ f	Cer	Var	281-007

HOW TO ORDER PARTS

Replacement parts are available through your local Tektronix Field Office.

Improvements in Tektronix instruments are incorporated as soon as available. Therefore, when ordering a replacement part it is important to supply the part number including any suffix, instrument type, serial number, plus a modification number where applicable.

If the part you have ordered has been improved or replaced, your local Field Office will contact you if there is a change in part number.

TYPE 127
 Mod. 3569
 S/N 950

R673 Add 47 ohm 1/2 w 10%

302-470

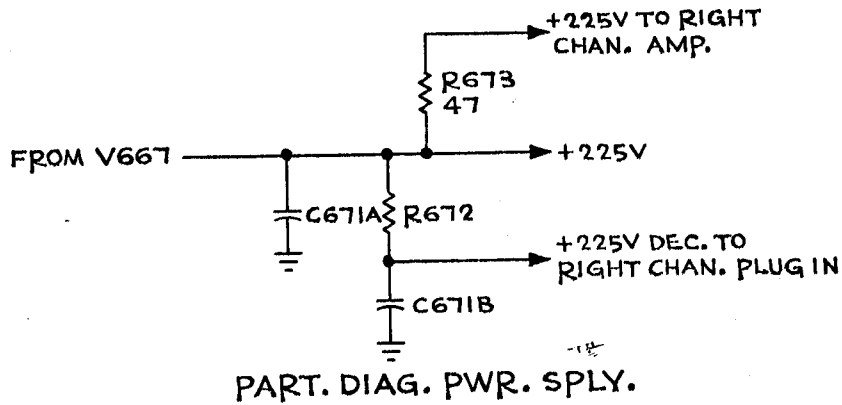

TYPE 127
 Part List Correction (4)

MECHANICAL

Should read:

PLATE,DUST COVER, TOP	SN101-649	386-758
PLATE,DUST COVER, TOP	SN650-up	387-032
PLATE,DUST COVER,BOTTOM	SN101-649	386-759
PLATE,DUST COVER,BOTTOM	SN650-up	387-033

PARTS LIST

Values are fixed unless marked Variable.

Circuit No.	Tektronix Part No.	Description	Serial No.
-------------	--------------------	-------------	------------

Bulbs

B601	150-018	Incandescent #12, GE	PILOT LIGHT
------	---------	----------------------	-------------

Capacitors

Tolerance $\pm 20\%$ unless otherwise indicated.

Tolerance of all electrolytic capacitors are as follows (with exceptions):

3 V — 50 V = $-10\% + 250\%$

51 V — 350 V = $-10\% + 100\%$

351 V — 450 V = $-10\% + 50\%$

C149	283-001	.005 μf	Discap	500 v	GMV	
C249	283-001	.005 μf	Discap	500 v	GMV	
C403A,B†	290-097	2 x 10 μf	EMC	450 v		
C407	283-000	.001 μf	Discap	500 v	GMV	
C419	283-002	.01 μf	Discap	500 v	GMV	
C421	281-005	1.5-7 μmf	Cer.	Var.		
C431	281-005	1.5-7 μmf	Cer.	Var.		
C503A,B†	290-097	2 x 10 μf	EMC	450 v		
C507	283-000	.001 μf	Discap	500 v	GMV	
C519	283-002	.01 μf	Discap	500 v	GMV	
C521	281-005	1.5-7 μmf	Cer.	Var.		
C531	281-005	1.5-7 μmf	Cer.	Var.		
C600	283-004	.02 μf	Discap	150 v	GMV	
C601	290-044	125 μf	EMC	350 v		
C603	290-048	150 μf	EMC	250 v		101-357
C603	290-082	2 x 200 μf	EMC	250 v		358-up
C604	290-048	150 μf	EMC	250 v		101-357X
C605	290-045	125 μf	EMC	450 v		
C609	290-044	125 μf	EMC	350 v		
C621	285-510	.01 μf	PTM	400 v		
C627	285-510	.01 μf	PTM	400 v		
C634	285-510	.01 μf	PTM	400 v		
C637	290-040	2 x 40 μf	EMC	250 v		
C638	290-040	2 x 40 μf	EMC	250 v		
C656	285-510	.01 μf	PTM	400 v		
C658A,B,	290-041	2 x 40 μf	EMC	250 v		
C670	285-510	.01 μf	PTM	400 v		
C671A,B,C,D,	290-097	4 x 10 μf	EMC	450 v		
C676	285-510	.01 μf	PTM	400 v		
C691	285-510	.01 μf	PTM	400 v		
C741	290-049	1000 μf	EMC	15 v		X358-up
C872	283-518	330 μmf	Mica	500 v	10%	
C875	283-518	330 μmf	Mica	500 v	10%	
C880A,B	290-034	2 x 15 μf	EMC	350 v		
C885	281-513	27 μmf	Cer.	500 v		
C897	283-000	.001 μf	Discap	500 v	GMV	

† C403A,B and C503A,B are concentric. Furnished as a unit.

Fuses

Circuit No.	Tektronix Part No.	Description	Serial No.
F601	159-006	5 Amp 3 AG Slo-Blo 117 V operation 50 cycles	
	159-014	5 Amp 3 AG Fast-Blo 117 V operation 60 cycles	
	159-005	3 Amp 3 AG Slo-Blo 234 V operation 50 cycle	
	159-015	3 Amp 3 AG Fast-Blo 234 V operation 60 cycle	

Inductors

LR149	*108-058	1 mh	
LR249	*108-058	1 mh	
L404	*114-090	10-22 μ h	Var.
L405	*114-091	2.7-5.4 μ h	Var.
L414	*114-090	10-22 μ h	Var.
L415	*114-091	2.7-5.4 μ h	Var.
L504	*114-090	10-22 μ h	Var.
L505	*114-091	2.7-5.4 μ h	Var.
L514	*114-090	10-22 μ h	Var.
L515	*114-091	2.7-5.4 μ h	Var.

Rectifiers

SR601A	}	*106-051	}	5-250 ma plates/leg	
SR601B				4-250 ma plates/leg	
SR603		*106-052		5-500 ma plates/leg	
SR607		*106-015		5-100 ma plates/leg	
SR741		*106-001		1-500 ma plate/leg	X358-up

Relays

K600	148-002	45-sec thermal time delay
K601	148-008	4 pole, single throw, underload
K751	148-004	6 V, 4 pole

Resistors

Resistors are fixed, composition, $\pm 10\%$ unless otherwise indicated.

R142	302-103	10 k	$\frac{1}{2}$ w
R143	302-103	10 k	$\frac{1}{2}$ w
R144	302-154	150 k	$\frac{1}{2}$ w
R148	304-332	3.3 k	1 w
R152	302-473	47 k	$\frac{1}{2}$ w
R153	302-105	1 meg	$\frac{1}{2}$ w
R154	302-103	10 k	$\frac{1}{2}$ w
R242	302-103	10 k	$\frac{1}{2}$ w
R243	302-103	10 k	$\frac{1}{2}$ w
R244	302-154	150 k	$\frac{1}{2}$ w
R248	304-332	3.3 k	1 w
R252	302-473	47 k	$\frac{1}{2}$ w
R253	302-105	1 meg	$\frac{1}{2}$ w
R254	302-103	10 k	$\frac{1}{2}$ w
R40i	302-470	47 Ω	$\frac{1}{2}$ w

Resistors (continued)

Circuit No.	Tektronix Part No.		Description			Serial No.
R403	302-473	47 k	1/2 w			
R404	*310-548	1.5 k	1/2 w		Mica Plate	1%
R407	302-474	470 k	1/2 w			
R408	304-222	2.2 k	1 w			
R409	311-006	1 k	2 w	Var.		Gain Adj.
R411	302-470	47 Ω	1/2 w			
R412	302-473	47 k	2 w			
R414	*310-548	1.5 k	1/2 w		Mica Plate	1%
R417	302-474	470 k	1/2 w			
R418	304-222	2.2 k	1 w			
R419	308-023	10 k	10 w		WW	5%
R421	310-064	500 k	1 w		Prec.	1%
R422	310-063	300 k	1 w		Prec.	1%
R423	311-049	5 k	2 w	Var.		DC Level Output B
R424	304-153	15 k	1 w			
R427	302-470	47 Ω	1/2 w			
R428	302-470	47 Ω	1/2 w			
R429	308-054	10 k	5 w		WW	5%
R431	310-064	500 k	1 w		Prec.	1%
R432	310-063	300 k	1 w		Prec.	1%
R433	311-049	5 k	2 w	Var.		DC Level Output A
R434	304-153	15 k	1 w			
R437	302-470	47 Ω	1/2 w			
R438	302-470	47 Ω	1/2 w			
R439	308-054	10 k	5 w		WW	5%
R501	302-470	47 Ω	1/2 w			
R503	302-473	47 k	1/2 w			
R504	*310-548	1.5 k	1/2 w		Mica Plate	1%
R507	302-474	470 k	1/2 w			
R508	304-222	2.2 k	1 w			
R509	311-006	1 k	2 w	Var.		Gain Adj.
R511	302-470	47 Ω	1/2 w			
R512	302-473	47 k	1/2 w			
R514	*310-548	1.5 k	1/2 w		Mica Plate	1%
R517	302-474	470 k	1/2 w			
R518	304-222	2.2 k	1 w			
R519	308-023	10 k	10 w		WW	5%
R521	310-064	500 k	1 w		Prec.	1%
R522	310-063	300 k	1 w		Prec.	1%
R523	311-049	5 k	2 w	Var.		DC Level Output B
R524	304-153	15 k	1 w			
R527	302-470	47 Ω	1/2 w			
R528	302-470	47 Ω	1/2 w			
R529	308-054	10 k	5 w		WW	5%
R531	310-064	500 k	1 w		Prec.	1%
R532	310-063	300 k	1 w		Prec.	1%
R533	311-049	5 k	2 w	Var.		DC Level Output A
R534	304-153	15 k	1 w			
R537	302-470	47 Ω	1/2 w			
R538	302-470	47 Ω	1/2 w			

Resistors (continued)

Circuit No.	Tektronix Part No.	Description				Serial No.
R539	308-054	10 k	5 w		WW	5%
R600	304-120	12 Ω	1 w			
R601	304-100	10 Ω	1 w			
R602	304-100	10 Ω	1 w			
R603	304-100	10 Ω	1 w			
R604	304-100	10 Ω	1 w			
R605	304-100	10 Ω	1 w			
R606	304-100	10 Ω	1 w			
R607	304-100	10 Ω	1 w			
R609	302-823	82 k	$\frac{1}{2}$ w			
R611	302-273	27 k	$\frac{1}{2}$ w			
R612	302-683	68 k	$\frac{1}{2}$ w			
R613	302-154	150 k	$\frac{1}{2}$ w			
R614	302-105	1 meg	$\frac{1}{2}$ w			
R615	302-153	15 k	$\frac{1}{2}$ w			
R616	302-153	15 k	$\frac{1}{2}$ w			
R617	302-102	1 k	$\frac{1}{2}$ w			
R618	302-102	1 k	$\frac{1}{2}$ w			
R619	308-024	15 k	10 w		WW	5%
R621	302-275	2.7 meg	$\frac{1}{2}$ w			
R622	302-275	2.7 meg	$\frac{1}{2}$ w			
R626	302-333	33 k	$\frac{1}{2}$ w			
R627	302-104	100 k	$\frac{1}{2}$ w			
R632	302-104	100 k	$\frac{1}{2}$ w			
R633	302-474	470 k	$\frac{1}{2}$ w			
R634	302-102	1 k	$\frac{1}{2}$ w			
R635	302-225	2.2 meg	$\frac{1}{2}$ w			
R636	310-054	68 k	1 w		Prec.	1%
R637	311-015	10 k	2 w	Var.	WW	—150 V Adj.
R638	310-086	50 k	1 w		Prec.	1%
R641	302-473	47 k	$\frac{1}{2}$ w			
R642	302-393	39 k	$\frac{1}{2}$ w			
R643	302-474	470 k	$\frac{1}{2}$ w			
R644	302-155	1.5 meg	$\frac{1}{2}$ w			
R651	302-102	1 k	$\frac{1}{2}$ w			
R652	302-102	1 k	$\frac{1}{2}$ w			
R653	308-028	200 Ω	20 w		WW	5%
R654	308-028	200 Ω	20 w		WW	5%
R655	308-016	750 Ω	10 w		WW	5%
R656	310-056	333 k	1 w		Prec.	1%
R657	310-057	490 k	1 w		Prec.	1%
R658	306-470	47 Ω	2 w			
R661	302-274	270 k	$\frac{1}{2}$ w			
R662	302-563	56 k	$\frac{1}{2}$ w			
R664	302-155	1.5 meg	$\frac{1}{2}$ w			
R667	302-102	1 k	$\frac{1}{2}$ w			
R668	302-102	1 k	$\frac{1}{2}$ w			
R669	308-040	1.5 k	25 w		WW	5%
R670	302-155	1.5 meg	$\frac{1}{2}$ w			
R671	302-225	2.2 meg	$\frac{1}{2}$ w			

Resistors (continued)

Circuit No.	Tektronix Part No.	Description		Serial No.		
R672	302-470	47 Ω	$\frac{1}{2}$ w	X950-up		
R673	302-470	47 Ω	$\frac{1}{2}$ w			
R674	302-184	180 k	$\frac{1}{2}$ w			
R675	302-823	82 k	$\frac{1}{2}$ w			
R676	302-102	1 k	$\frac{1}{2}$ w			
R677	302-225	2.2 meg	$\frac{1}{2}$ w			
R678	310-056	333 k	1 w	Prec.	1%	
R679	310-055	220 k	1 w	Prec.	1%	
R681	302-394	390 k	$\frac{1}{2}$ w			
R682	302-273	27 k	$\frac{1}{2}$ w			
R683	302-394	390 k	$\frac{1}{2}$ w			
R684	302-185	1.8 meg	$\frac{1}{2}$ w			
R687	302-102	1 k	$\frac{1}{2}$ w			
R691	309-020	1.8 meg	$\frac{1}{2}$ w	Prec.	1%	101-357
R691	308-083	236 k	1 w	WW	1%	358-789
R691	310-124	237 k	1 w	Prec.	1%	790-up
R692	309-011	780 k	$\frac{1}{2}$ w	Prec.	1%	101-357
R692	use 309-334	100 k	$\frac{1}{2}$ w	WW	1%	358-798
R692	309-334	100 k	$\frac{1}{2}$ w	Prec.	1%	790-up
R697	302-102	1 k	$\frac{1}{2}$ w			
R699	302-470	47 Ω	$\frac{1}{2}$ w			
R721	302-823	82 k	$\frac{1}{2}$ w			
R731	302-104	100 k	$\frac{1}{2}$ w			
R741	302-104	100 k	$\frac{1}{2}$ w			
R741	302-102	1 k	$\frac{1}{2}$ w			
R751	308-114	600 Ω	25 w	WW	5%	101-357 358-up
R752	308-023	10 k	10 w	WW	5%	
R753	304-393	39 k	1 w			
R870	302-154	150 k	$\frac{1}{2}$ w			
R871	302-102	1 k	$\frac{1}{2}$ w			
R872	302-335	3.3 meg	$\frac{1}{2}$ w			
R874	302-683	68 k	$\frac{1}{2}$ w			
R875	302-275	2.7 meg	$\frac{1}{2}$ w			
R876	302-102	1 k	$\frac{1}{2}$ w			
R878	304-333	33 k	1 w			
R879	311-016	10 k	2 w	Var.		Cal. Adj.
R880	302-104	100 k	$\frac{1}{2}$ w			
R882	302-155	1.5 meg	$\frac{1}{2}$ w			
R883	302-101	100 Ω	$\frac{1}{2}$ w			
R885	309-121	9.5 k	$\frac{1}{2}$ w	Prec.	1%	
R886	309-119	6.375 k	$\frac{1}{2}$ w	Prec.	1%	
R887	309-117	2.1 k	$\frac{1}{2}$ w	Prec.	1%	
R888	309-116	1.025 k	$\frac{1}{2}$ w	Prec.	1%	
R889	309-113	610 Ω	$\frac{1}{2}$ w	Prec.	1%	
R890	309-073	200 Ω	$\frac{1}{2}$ w	Prec.	1%	
R891	309-112	100 Ω	$\frac{1}{2}$ w	Prec.	1%	
R892	309-067	60 Ω	$\frac{1}{2}$ w	Prec.	1%	
R893	309-066	40 Ω	$\frac{1}{2}$ w	Prec.	1%	
R896	309-045	100 k	$\frac{1}{2}$ w	Prec.	1%	
R897	309-112	100 Ω	$\frac{1}{2}$ w	Prec.	1%	
R898	*308-090	0.25 Ω	1 w	WW		
R899	302-101	100 Ω	$\frac{1}{2}$ w			

Switches

Circuit No.	Tektronix Part No.	Description		Serial No.
		Unwired	Wired	
SW601	260-134		Toggle	POWER ON
SW870	*260-177	*262-132	Rotary	VOLTS MILLIVOLTS OFF SQUARE-WAVE CALIBRATOR
TK601	260-120		Thermal Cutout, 137° ±5°	

Transformer

T601	*120-101	LV Power
------	----------	----------

Electron Tubes

V154	154-033	6U8
V254	154-033	6U8
V404	154-030	6CB6
V414	154-030	6CB6
V423	154-039	12AT7
V433	154-039	12AT7
V504	154-030	6CB6
V514	154-030	6CB6
V523	154-039	12AT7
V533	154-039	12AT7
V614	154-022	6AU6
V617	154-056	6080
V629	154-052	5651
V634	154-043	12AX7
V644	154-022	6AU6
V657	154-056	6080
V664	154-022	6AU6
V667	154-056	6080
V674	154-043	12AX7
V684	154-022	6AU6
V687	154-044	12B4
V697	154-044	12B4
V873A,B	154-039	12AT7
V875	154-022	6AU6

Mechanical Parts List

Type 127

	Tektronix Part Number
BAR, ALUM. FRAME $\frac{3}{4} \times \frac{3}{4} \times 16\frac{1}{2}$	381-096
BRACKET, $1 \times 1\frac{5}{16} \times \frac{9}{16}$	406-031
BRACKET, $1\frac{1}{2} \times 4\frac{1}{2} \times \frac{5}{8}$	406-128
BRACKET, $\frac{3}{4} \times 1\frac{3}{8}$, nylon molded coax insul.	406-244
BRACKET, $1\frac{17}{32} \times 4\frac{3}{8}$, pot	406-325
BUSHING, NYLON, for binding post	358-036
BUSHING, NYLON, $\frac{3}{8}$ -32 x $\frac{5}{8} \times \frac{3}{4}$, pot insul.	358-038
CABLE HARNESS, POWER SN 101-357	179-217
CABLE HARNESS, PREAMP #1 SN 101-357	179-218
CABLE HARNESS, 110 VOLT	179-219
CABLE HARNESS, PREAMP #2	179-220
CABLE HARNESS, POWER SN 358-up	179-321
CABLE HARNESS, PREAMP #1 SN 358-up	179-322
CAP, FUSE 3 AG	200-015
CAP, BINDING POST	200-103
CHASSIS, AMPLIFIER	441-181
CHASSIS, POWER SN 101-357	441-182
CHASSIS, POWER SN 358-up	441-244
CLAMP, CABLE $\frac{5}{16}$ " plastic	343-004
CONNECTOR, CHASSIS MT., 16-contact	131-018
CONNECTOR, CHASSIS MT., 83-IRTY cut	131-038
CONNECTOR, CHASSIS MT., Cal Out	131-064
CONNECTOR, CHASSIS MT., 3-wire	131-102
CORD, POWER 8' 16 gauge, 3-wire	161-010
EYELET, BRASS	210-601
FAN BLADE	369-001
FAN MOTOR	147-001
FILTER, AIR	378-015
GROMMET, $\frac{1}{4}$ "	348-002
GROMMET, $\frac{5}{16}$ "	348-003
GROMMET, $\frac{3}{8}$ "	348-004
GROMMET, $\frac{1}{2}$ "	348-005
GROMMET, $\frac{1}{2}$ " dia. x $\frac{1}{2}$ " hi.	348-008
GROMMET, $\frac{5}{8}$ "	348-012

Mechanical Parts List (continued)

	Tektronix Part Number
HANDLE	367-008
HOLDER, FUSE 3AG	352-010
HOUSING, AIR FILTER	380-009
JEWEL, PILOT LIGHT	378-517
KNOB, LARGE BLACK	366-040
KNOB, SMALL GREY	366-061
LOCKWASHER #2 Int.	210-001
LOCKWASHER #2 Ext.	210-002
LOCKWASHER #4 Int.	210-004
LOCKWASHER #6 Int.	210-006
LOCKWASHER #8 Ext.	210-007
LOCKWASHER #8 Int.	210-008
LOCKWASHER #10 Ext.	210-009
LOCKWASHER #10 Int.	210-010
LOCKWASHER 1/4" Int.	210-011
LOCKWASHER 3/8 x 1/2, Int., Pot	210-012
LUG, SOLDER SE4	210-201
LUG, SOLDER SE6	210-202
LUG, SOLDER SE8	210-205
LUG, SOLDER SE10	210-206
LUG, SOLDER Pot, plain	210-207
LUG, SOLDER 1/4" hole lock round perimeter	210-223
LUG, SOLDER #10 non-locking	210-224
MOUNT, FAN MOTOR	426-046
NUT, CAP 8-32 x 5/16	210-402
NUT, HEX 2-56 x 3/16	210-405
NUT, HEX 4-40 x 3/16	210-406
NUT, HEX 6-32 x 1/4	210-407
NUT, HEX 8-32 x 5/16	210-409
NUT, HEX 10-32 x 5/16	210-410
NUT, HEX 3/8-32 x 1/2	210-413
NUT, HEX 15/32-32 x 9/16	210-414
NUT, HEX 3/8-32 x 1/2 x 5/8 long	210-444
NUT, HEX 10-32 x 3/8 x 1/8	210-445
NUT, HEX 1/4-28 x 3/8 x 3/32	210-455
NUT, KEP 6-32 x 5/16	210-457

Mechanical Parts List (continued)

	Tektronix Part Number
NUT, KEP 8-32 x 1 ¹ / ₃₂	210-458
NUT, HEX 5 ⁵ / ₁₆ -32 x 1 ¹ / ₂ (for jewel ass'y)	210-459
NUT, HEX 8-32 x 1 ¹ / ₂ (25 w resistor mtg.)	210-462
NUT, HEX Switch, 12-sided	210-473
PANEL, FRONT SN 101-185	333-376
PANEL, FRONT SN 186-up	333-526
PLATE, PLUG-IN HOUSING 7 ⁷ / ₈ x 5 ⁷ / ₈	386-687
PLATE, SUBPANEL	386-707
PLATE, LEFT SIDE ASS'Y 8 ¹ / ₄ x 20 ¹⁷ / ₆₄ SN 101-308	386-723
PLATE, BACK 9 ⁵ / ₁₆ x 17 ¹ / ₁₆	386-724
PLATE, PLUG-IN HOUSING BACK 8 ¹ / ₃₂ x 17 ¹³ / ₁₆	386-725
PLATE, SECURING 3 ³ / ₈ x 1 ⁷ / ₈	386-726
PLATE, SECURING 3 ³ / ₈ x 4 ¹ / ₂	386-727
PLATE, RIGHT SIDE ASS'Y 8 ¹ / ₄ x 20 ¹⁷ / ₆₄ SN 101-308	386-728
PLATE, PLUG-IN HOUSING SIDE 9 ¹ / ₈ x 6 ¹⁷ / ₁₆	386-734
PLATE, DUST COVER, TOP	386-758
PLATE, DUST COVER, BOTTOM	386-759
PLATE, LEFT SIDE ASS'Y SN 309-up	386-893
PLATE, RIGHT SIDE ASS'Y SN 309-up	386-894
POST, CERAMIC 1"	129-017
POST, BINDING	129-030
RING, FAN w/mtg. ears	354-051
RING, LOCKING SWITCH	354-055
ROD, SPACING 3 ³ / ₈ x 5 ¹ / ₈	384-540
ROD, NYLON 5 ⁵ / ₁₆ x 1 ¹ / ₈	385-075
ROD, NYLON 5 ⁵ / ₁₆ x 2 ³ / ₈	385-108
SCREW 4-40 x 5 ⁵ / ₈ RHS	211-016
SCREW 4-40 x 3 ³ / ₈ FHS	211-025
SCREW 4-40 x 5 ⁵ / ₁₆ Pan HS w/lockwasher	211-033
SCREW 4-40 x 5 ⁵ / ₁₆ FHS Phillips	211-038
SCREW 6-32 x 3 ³ / ₁₆ BHS	211-503
SCREW 6-32 x 1 ¹ / ₄ BHS	211-504
SCREW 6-32 x 5 ⁵ / ₁₆ FHS	211-507
SCREW 6-32 x 3 ³ / ₈ BHS	211-510
SCREW 6-32 x 5 ⁵ / ₁₆ Pan HS w/lockwasher	211-534
SCREW 6-32 x 3 ³ / ₈ Truss Phillips	211-537

Mechanical Parts List (continued)

	Tektronix Part Number
SCREW 6-32 x 5/16 FHS Phillips	211-538
SCREW 6-32 x 5/16 Truss Phillips	211-542
SCREW 6-32 x 5/16 RHS	211-543
SCREW 8-32 x 1/4 FHS	212-002
SCREW 8-32 x 5/16 BHS	212-004
SCREW 8-32 x 2 1/4 RHS	212-014
SCREW 8-32 x 1 1/4 RHS	212-031
SCREW 8-32 x 1 3/4 FHS	212-037
SCREW 8-32 x 3/8 Truss Phillips	212-039
SCREW 8-32 x 3/8 FHS Phillips	212-040
SCREW 10-32 x 3/8 FHS	212-506
SCREW 10-32 x 3/8 BHS	212-507
SCREW 10-32 x 1 BHS	212-534
SCREW, THREAD CUTTING 4-40 x 1/4 PHS Phillips	213-035
SCREW 1/4-20 x 1 HH Sems w/pinch point taper	213-052
SCREW 1/4-20 x 3/4 HH Sems w/pinch point taper	213-053
SHIELD, SOCKET STS 129 .770"	337-004
SHIELD, SOCKET STS 179 29/32 ID	337-005
SHIELD, 3 7/16 x 4 1/2 x 1/2	337-200
SHIELD, 1 1/4 x 3 x 3/8	337-255
SHIELD, 1 x 1 3/8	337-258
SLIDES, CHASSIS TRAK, 1 pr., left and right	351-007
SOCKET, STM7G	136-008
SOCKET, STM8 Ground	136-011
SOCKET, STM9G	136-015
SOCKET, Tip Jack	136-037
SOCKET, LIGHT w/red jewel ass'y	136-047
SPACER, for ceramic strips	361-009
STEM, BINDING POST ADAPTOR 3/8 x 1 3/16	355-507
STRIP, CERAMIC 3/4 x 3 clip-mounted	124-087
STRIP, CERAMIC 3/4 x 4 clip-mounted	124-088
STRIP, CERAMIC 3/4 x 7 clip-mounted	124-089
STRIP, CERAMIC 3/4 x 9 clip-mounted	124-090
STRIP, CERAMIC 3/4 x 11 clip-mounted	124-091
STUD, STEEL 10-32 x 2 7/16	355-044
WASHER 6S x 5/16	210-802

Mechanical Parts List (continued)

	Tektronix Part Number
WASHER 8S x $\frac{3}{8}$	210-804
WASHER 10S x $\frac{7}{16}$	210-805
WASHER, 20 w resistor centering	210-808
WASHER, 25 w resistor centering	210-809
WASHER, #10 fiber	210-812
WASHER, $\frac{1}{4}$ ID x $\frac{1}{2}$ OD, bakelite	210-819
WASHER, $\frac{1}{4}$ ID x $\frac{1}{2}$ OD, alum.	210-821
WASHER, .390 ID x $\frac{9}{16}$ OD	210-840
WASHER, #2 .093 ID x $\frac{9}{32}$ OD	210-850
WASHER, #4L, .119 ID x $\frac{3}{8}$ OD	210-851
WASHER, $\frac{17}{64}$ ID x $\frac{1}{2}$ OD, alum.	210-854
WASHER, $\frac{1}{2}$ ID x $\frac{11}{16}$ OD, rubber (for fuse holder)	210-873

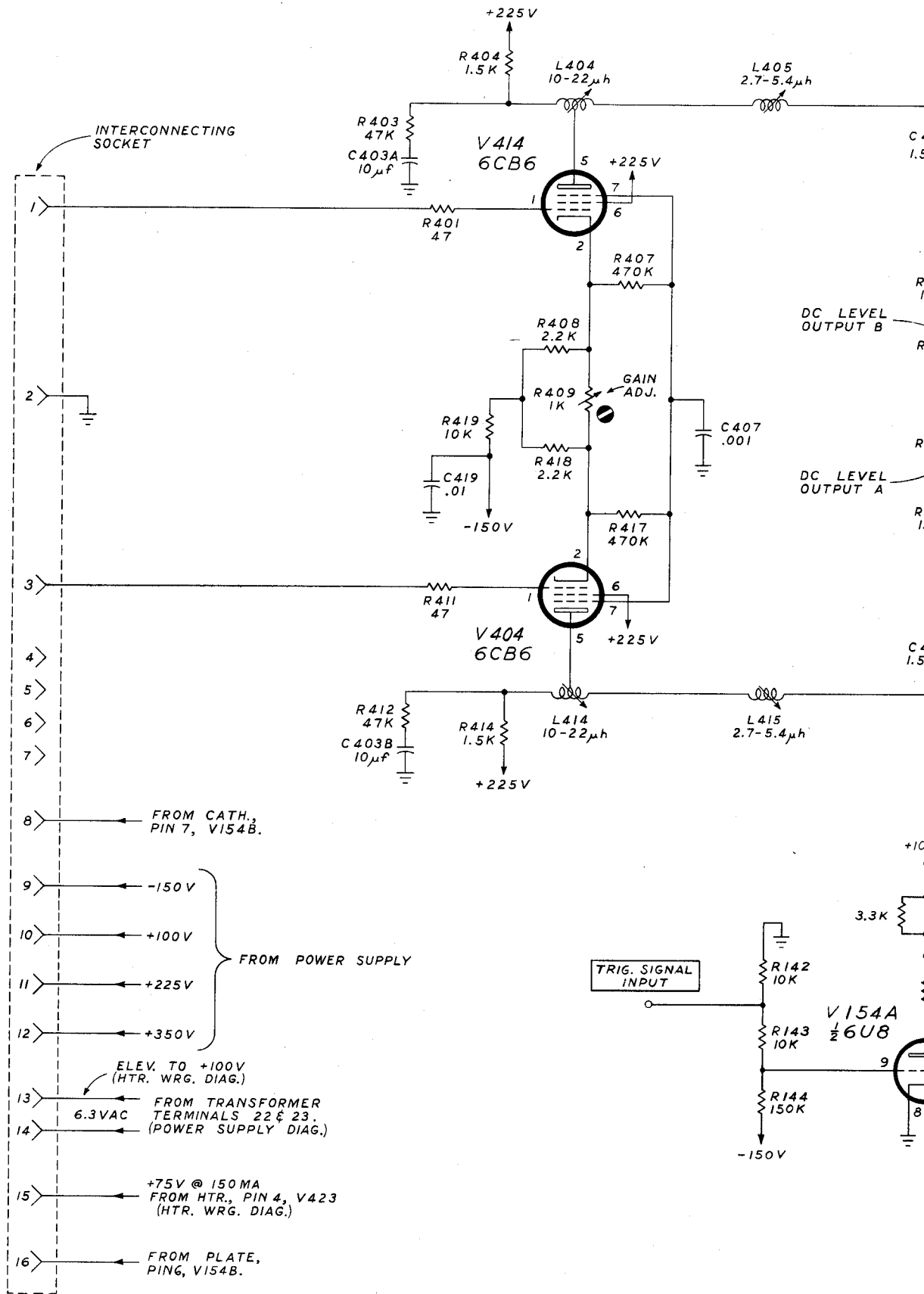

TYPE 127

AA

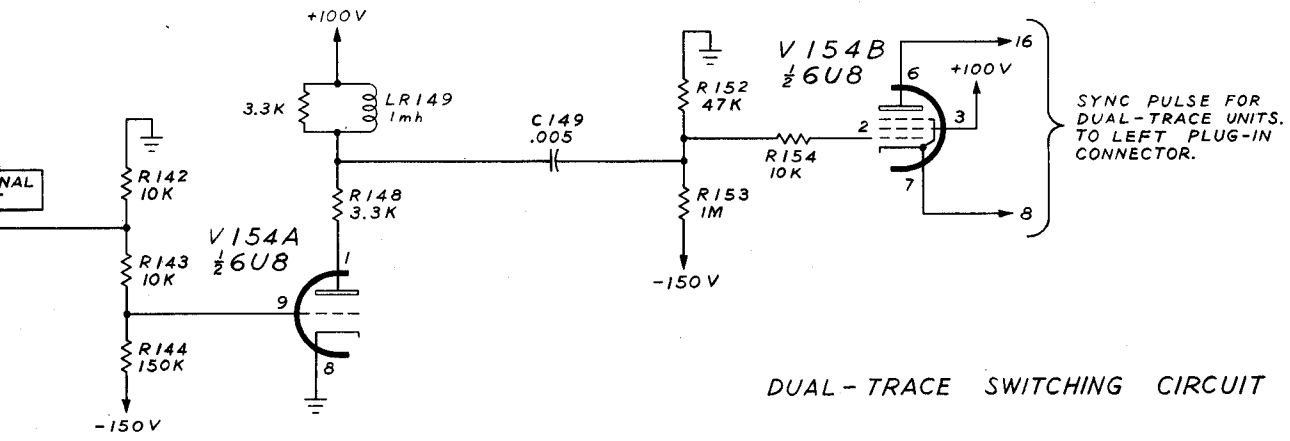
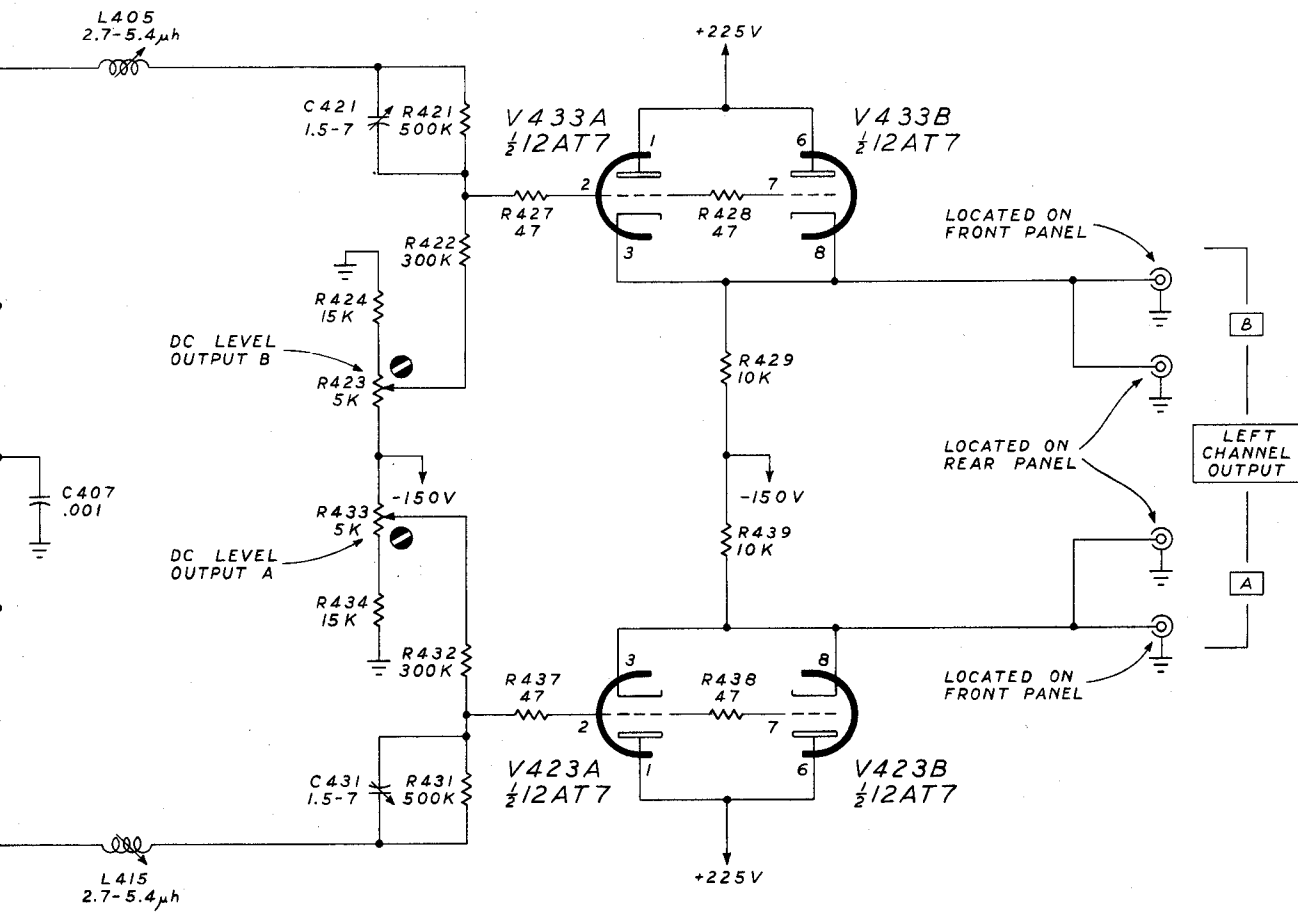

DUAL-TRACE SWITCHING CIRCUIT

R.E.C.
3-23-61

AA

LEFT CHANNEL AMPLIFIER

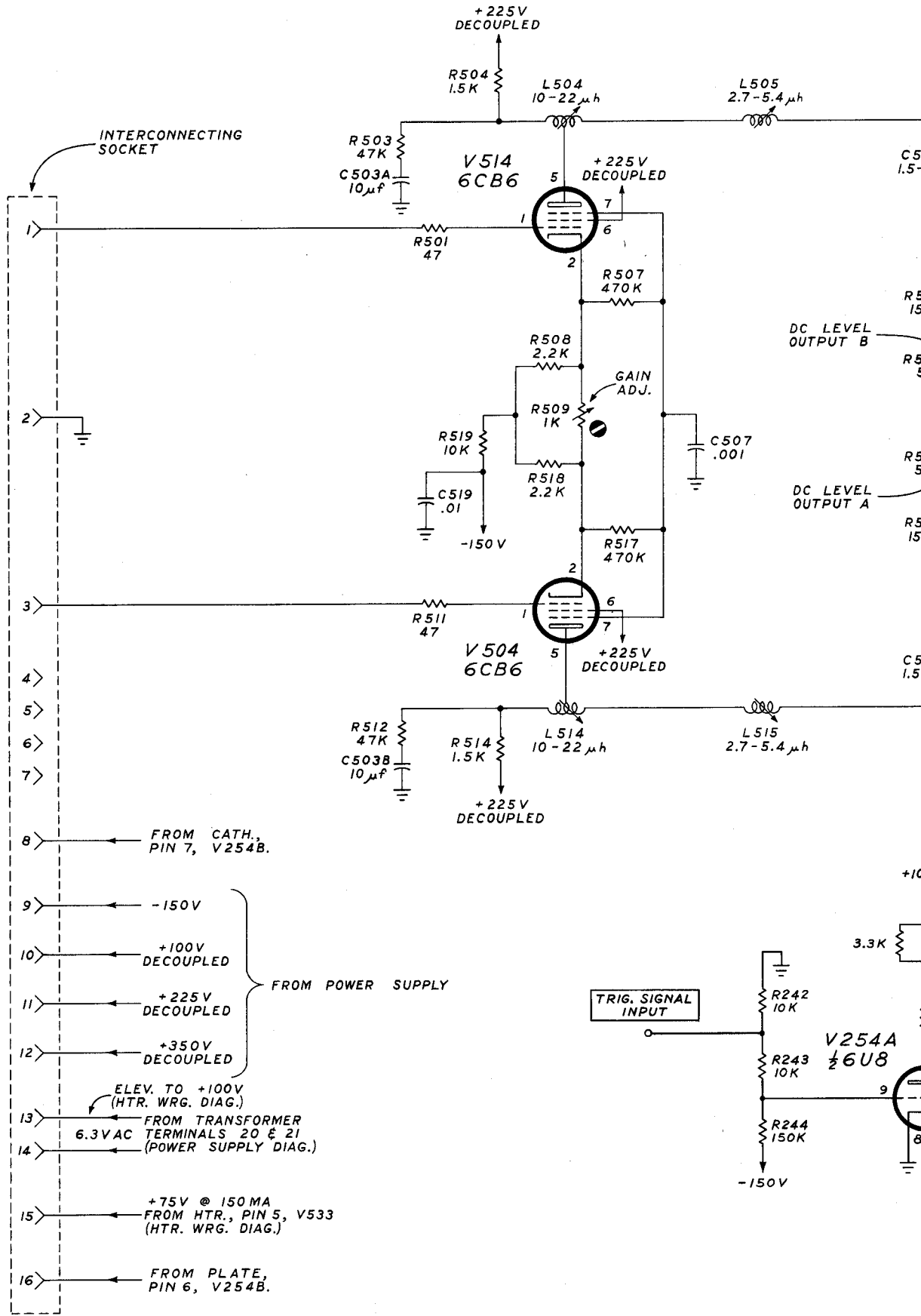

TYPE 127

AA

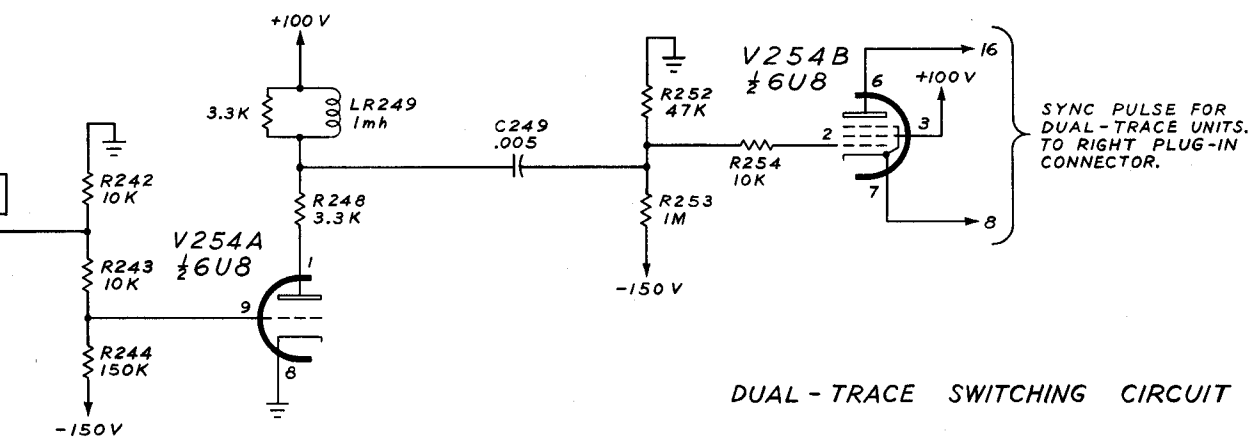
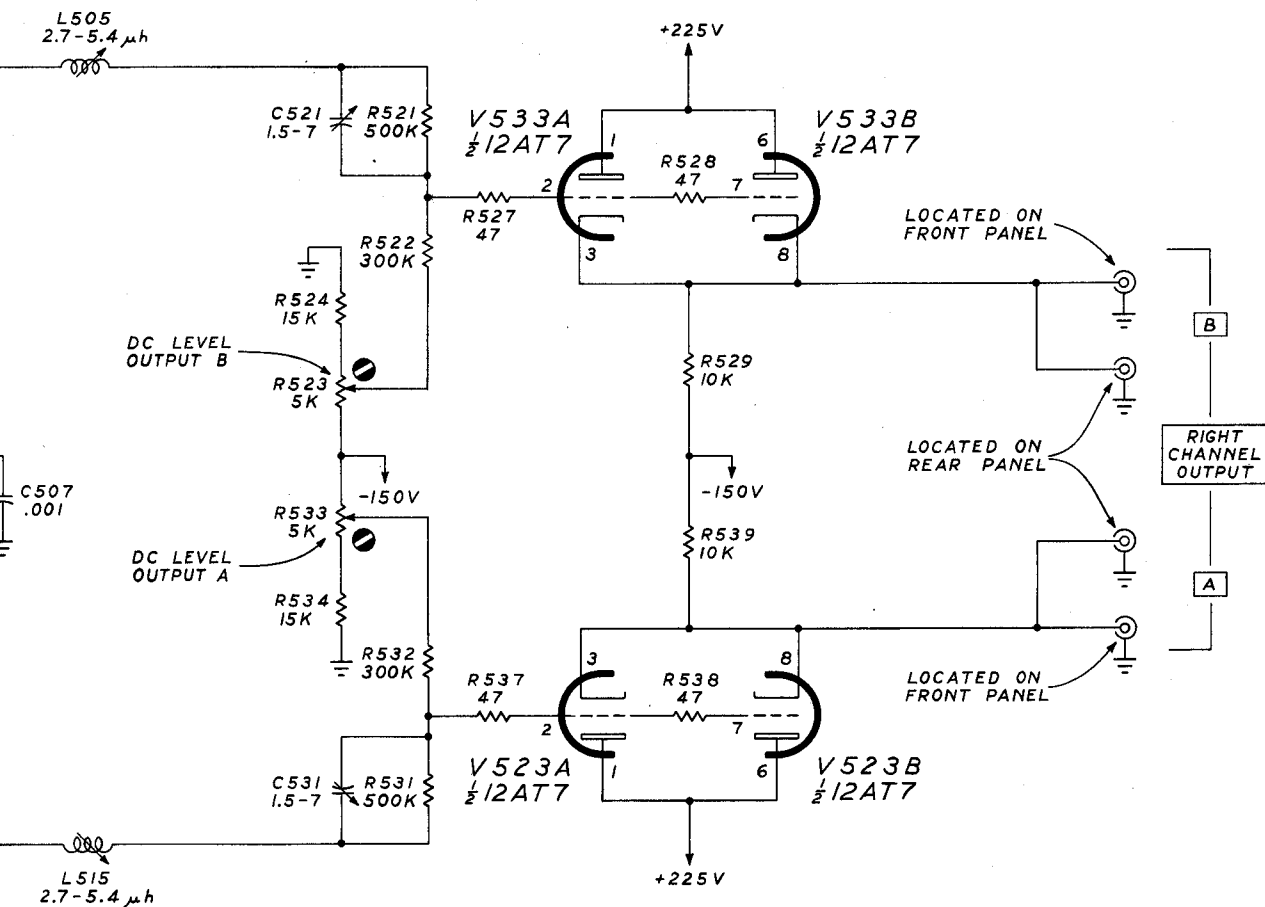

DUAL-TRACE SWITCHING CIRCUIT

R.E.C.
3-23-61

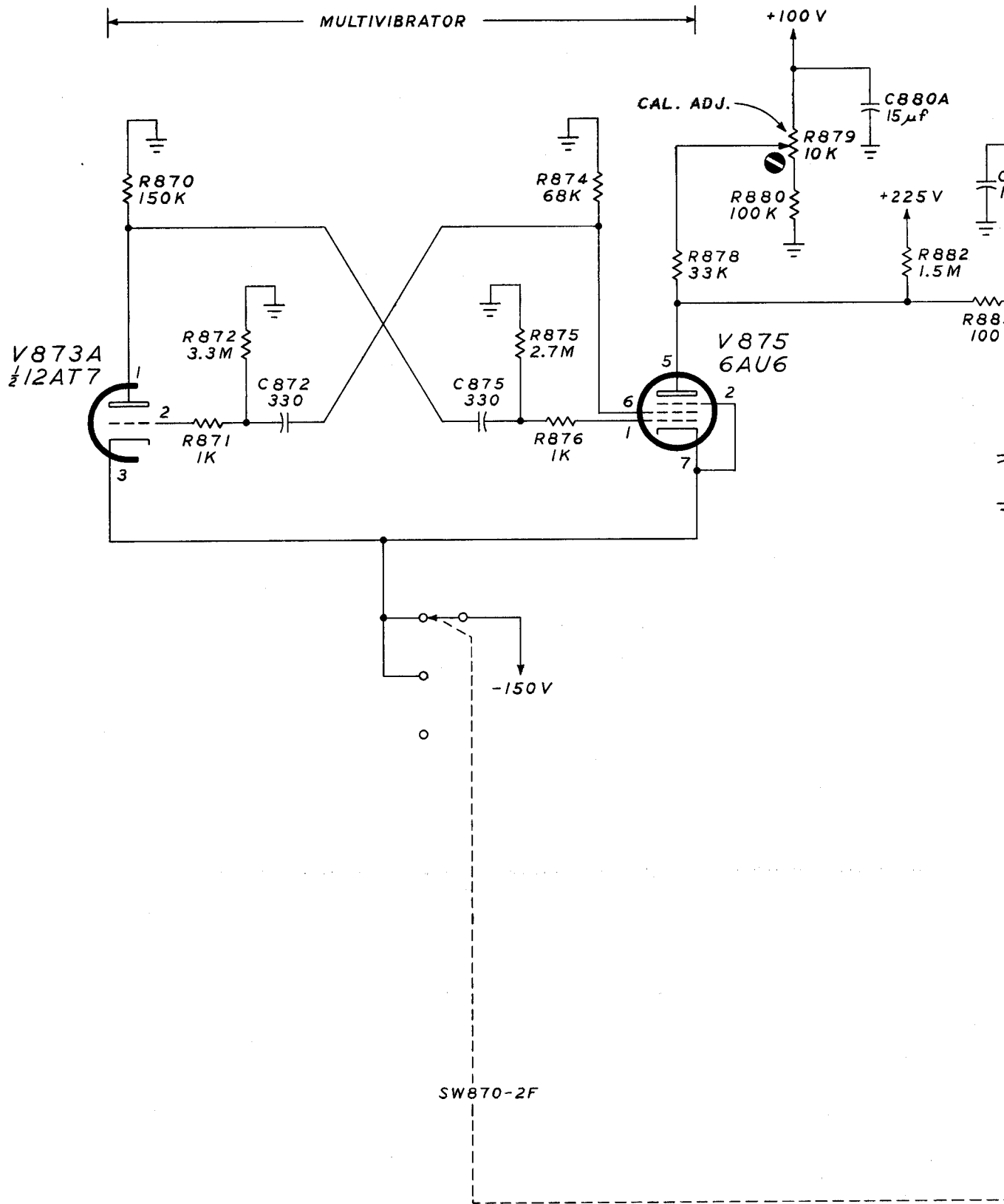

TYPE 127

AA

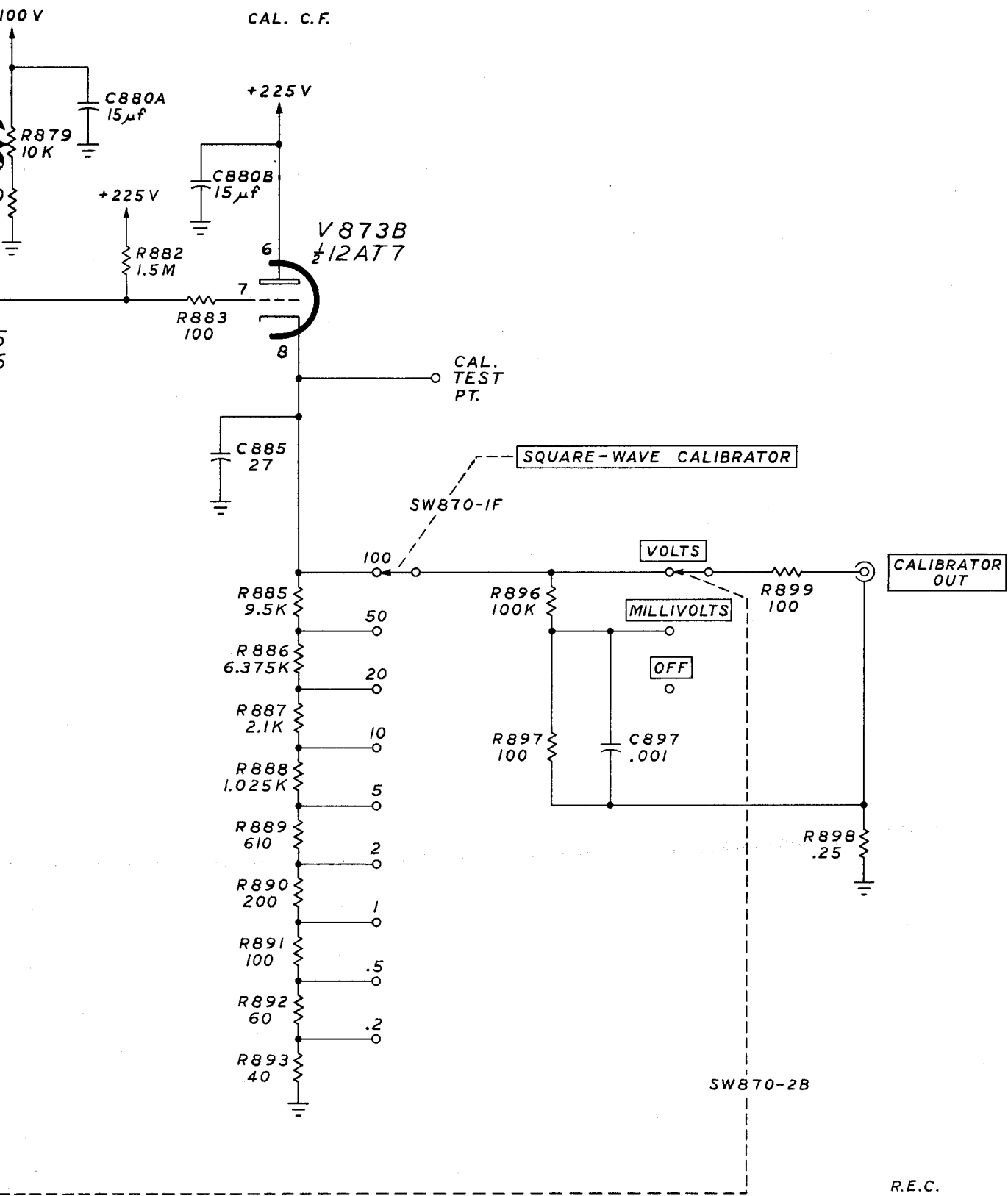

AA

CALIBRATOR

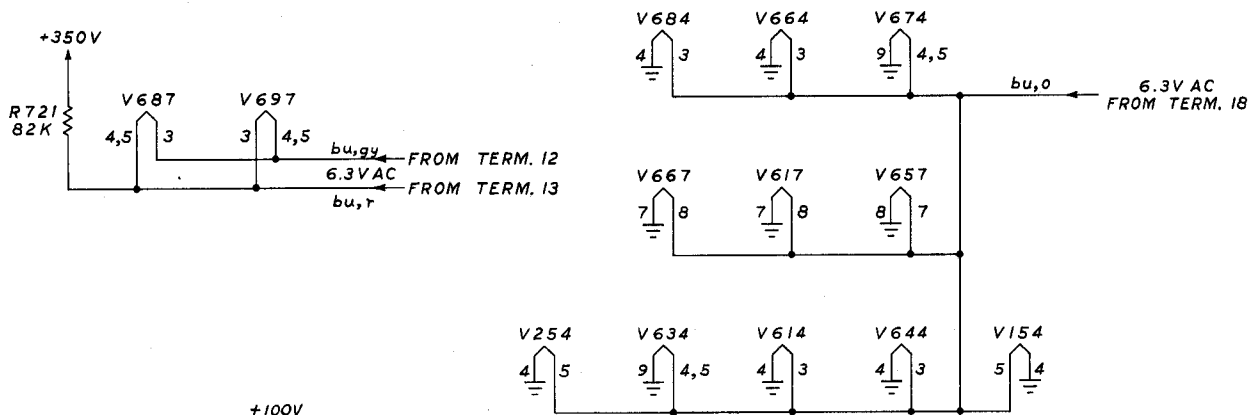

POWER SUPPLY CHASSIS

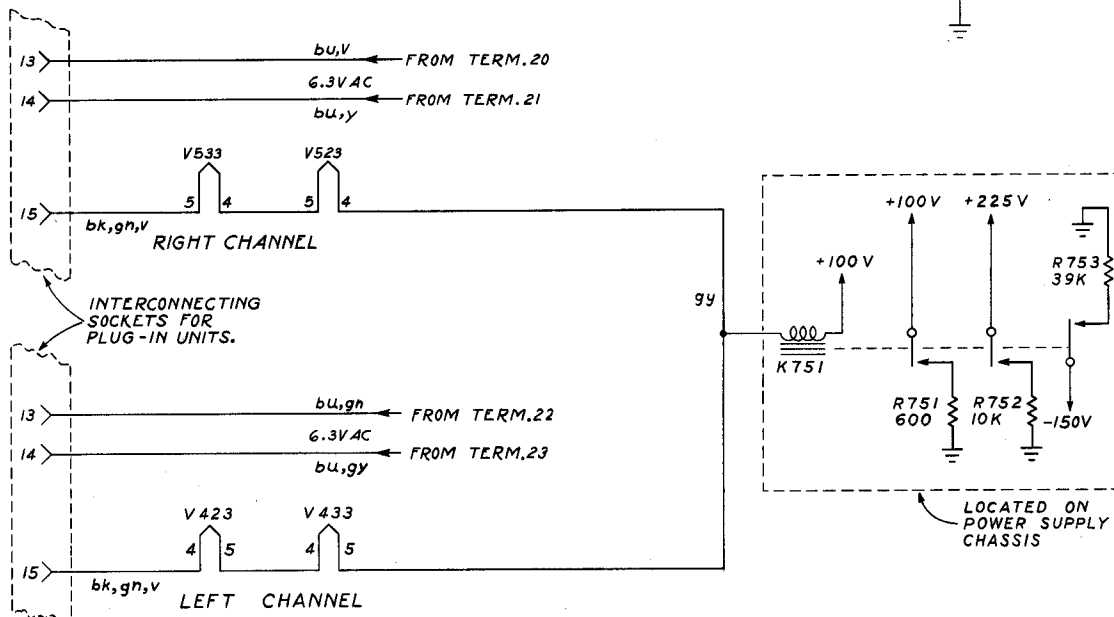
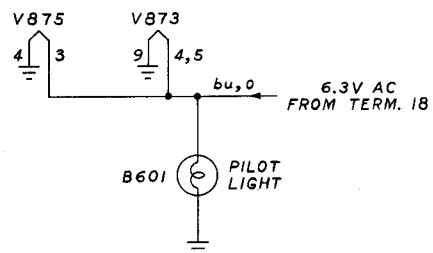
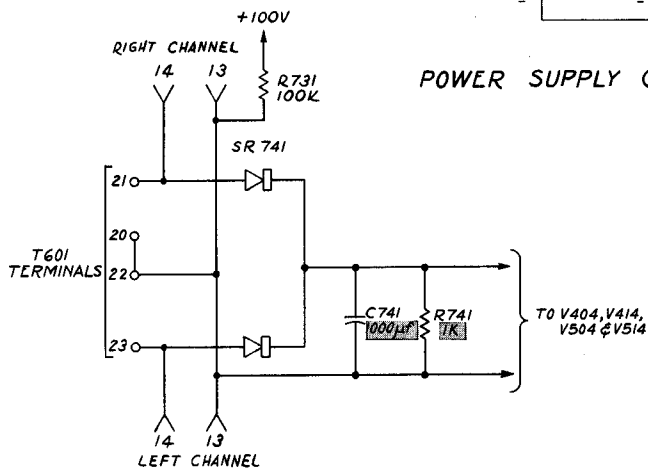

AMPLIFIER CHASSIS

R.E.C.
3-23-61

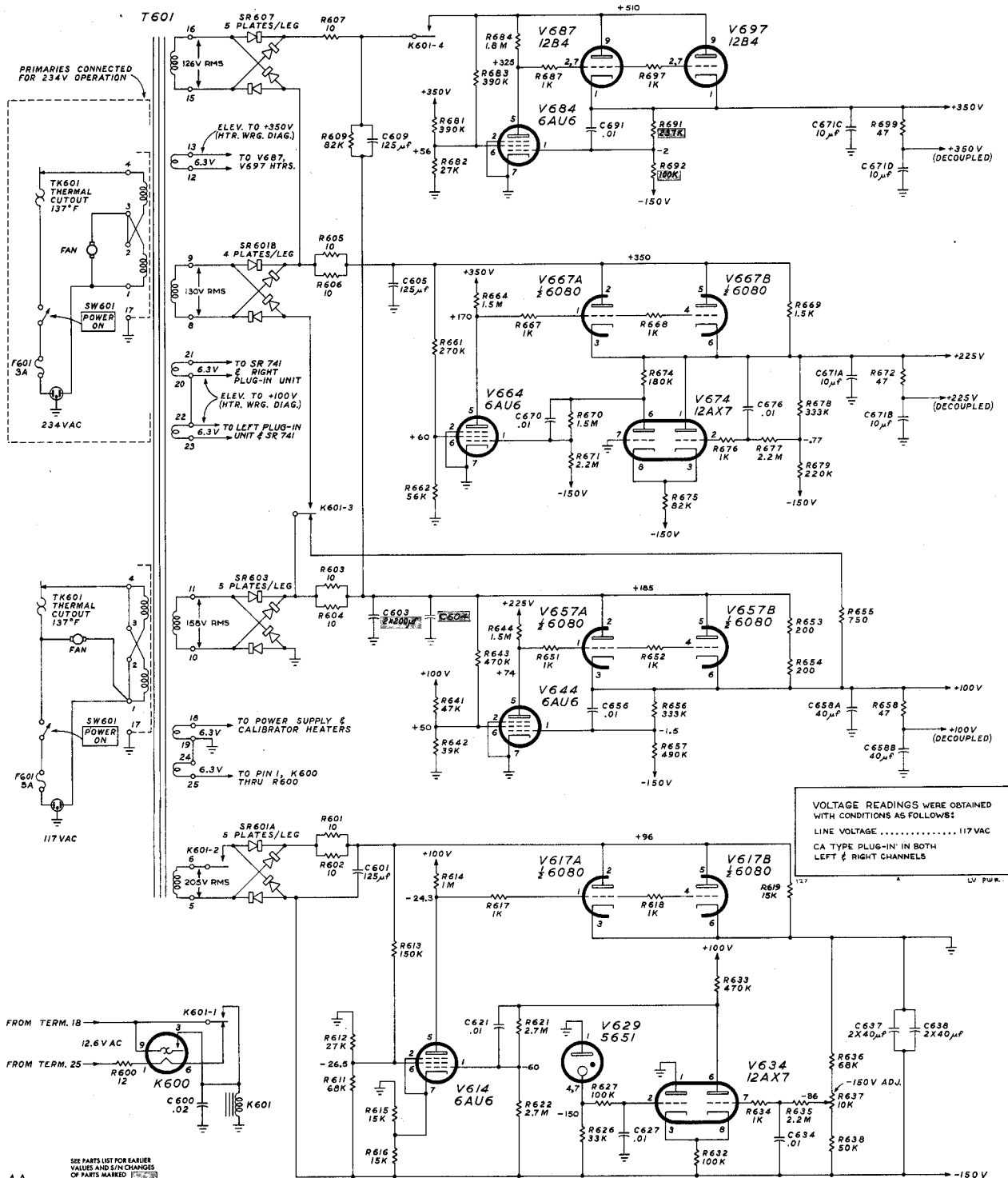

PRIMARIES CONNECTED FOR 234V OPERATION

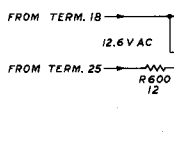
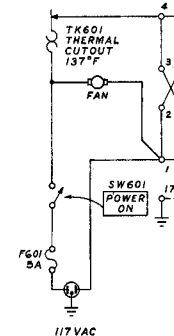
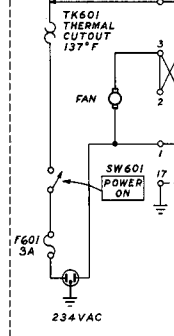

SEE PARTS LIST FOR EARLIER VALUES AND S/N CHANGES OF PARTS MARKED

K4XL's **BAMA**

This manual is provided **FREE OF CHARGE** from the "BoatAnchor Manual Archive" as a service to the Boatanchor community.

It was uploaded by someone who wanted to help you repair and maintain your equipment.

If you paid anyone other than BAMA for this manual, you paid someone who is making a profit from the free labor of others without asking their permission.

You may pass on copies of this manual to anyone who needs it. But do it without charge.

Thousands of files are available without charge from BAMA. Visit us at <http://bama.sbc.edu>