

**NOTES:**

1. BREAK ALL EDGES.
2. SHEET 1 IS ENGLISH UNITS, SHEET 2 IS SI UNITS.
3. CUT THREADS WITH LATHE TO GET THREAD DEPTH.

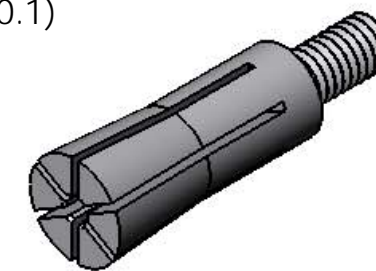

**SECTION A-A**

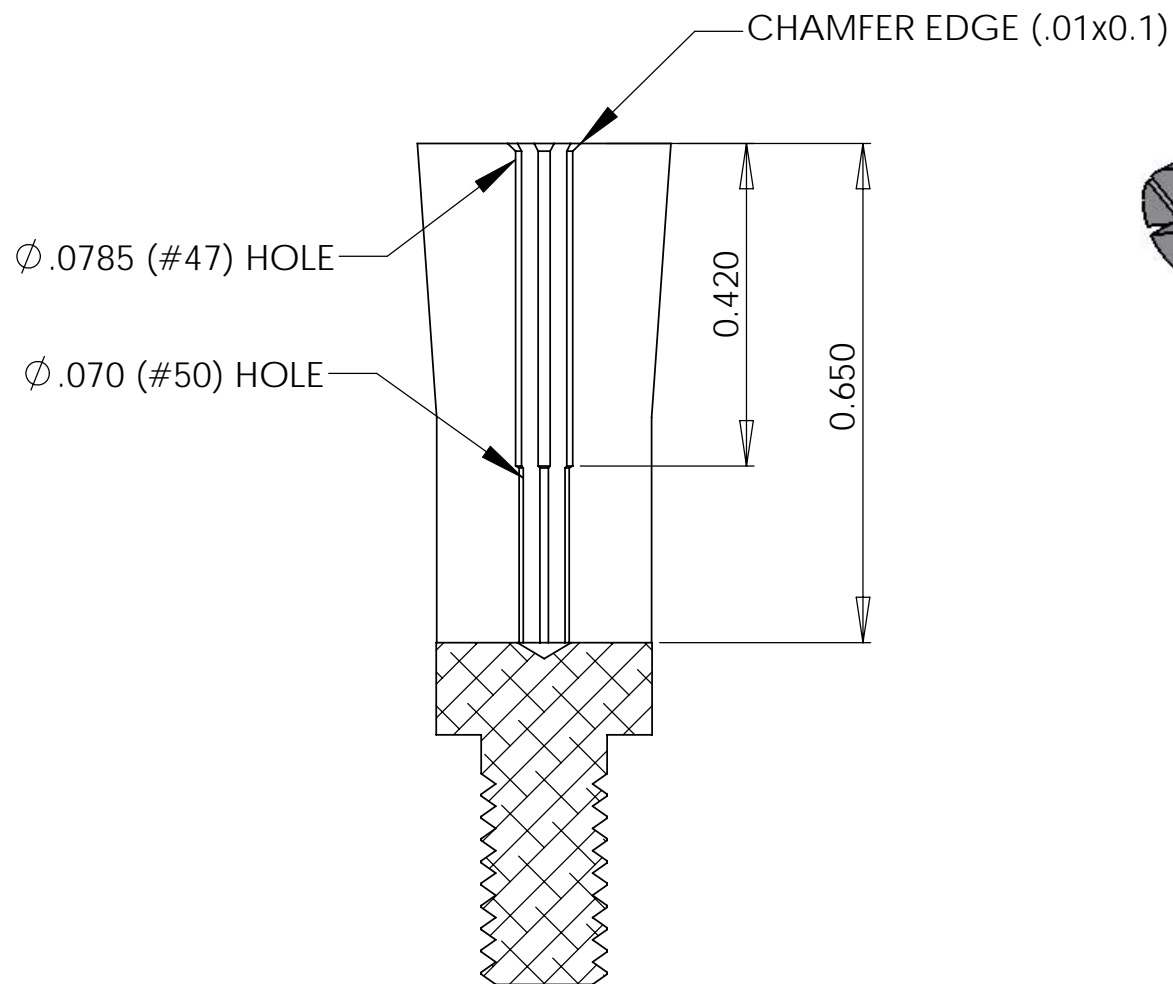
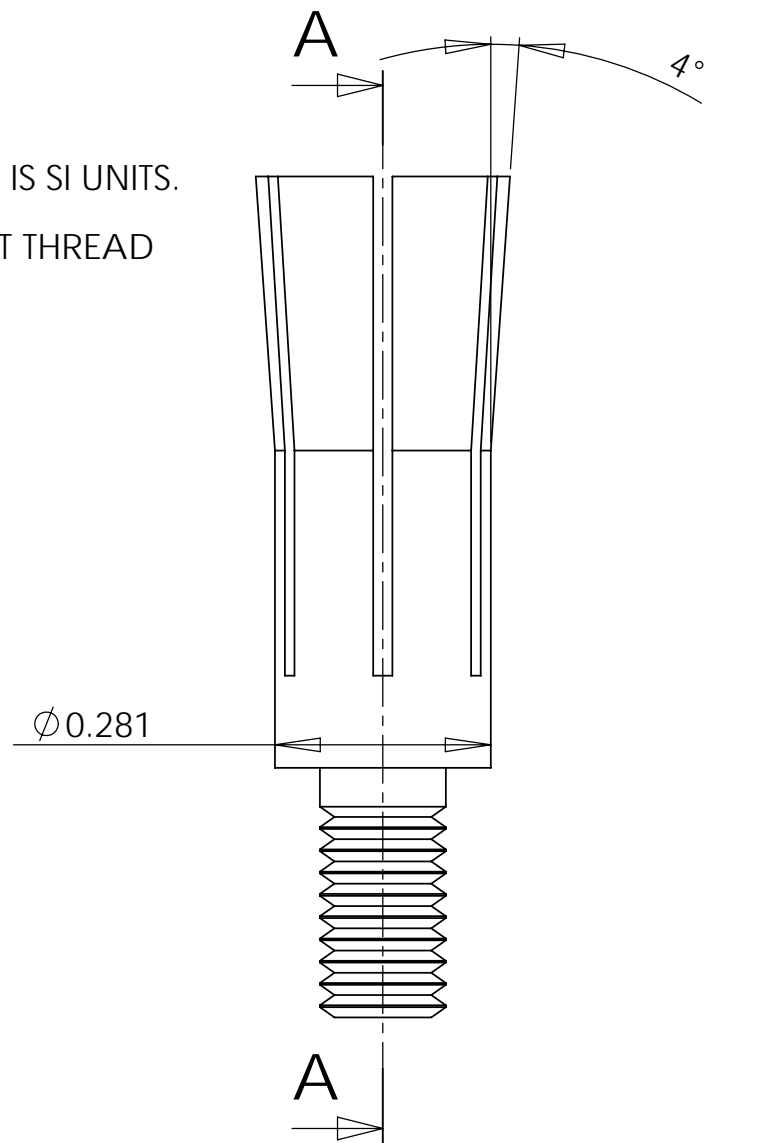
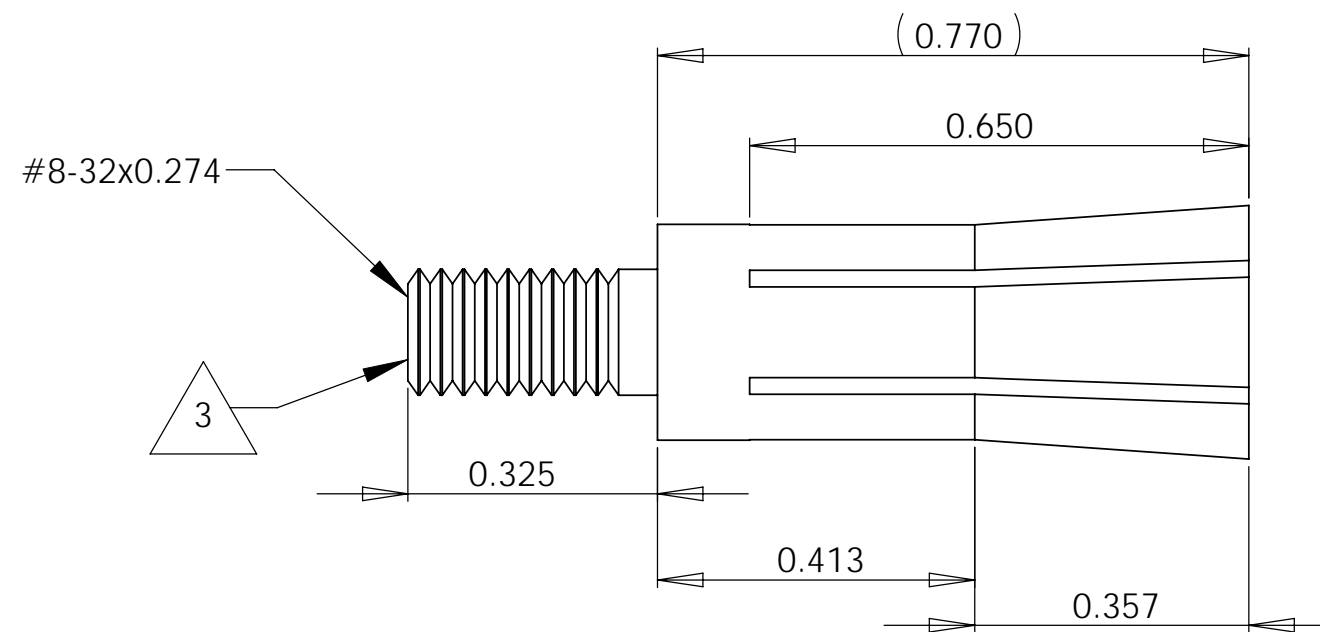
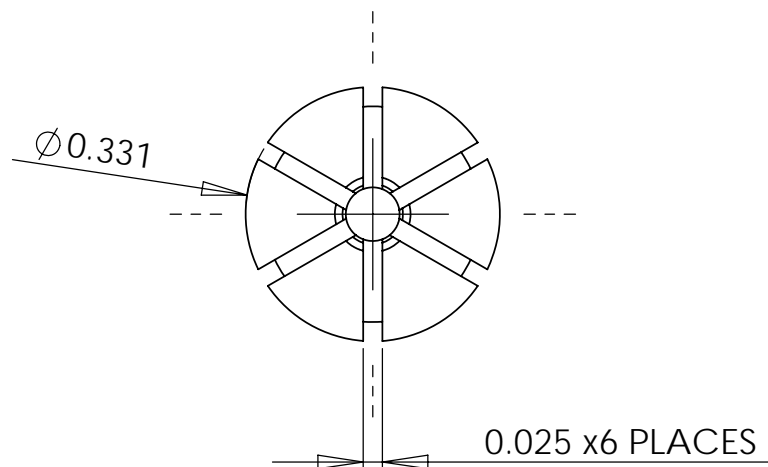

**PROPRIETARY AND CONFIDENTIAL**  
THE INFORMATION CONTAINED IN THIS DRAWING IS THE SOLE PROPERTY OF THE SPECTRANETICS CORPORATION. ANY REPRODUCTION IN PART OR AS A WHOLE WITHOUT WRITTEN PERMISSION IS PROHIBITED.

TOLERANCES:  
X.X ±0.050  
X.XX ±0.010  
X.XXX ±0.005  
X° ±0.5°

UNLESS OTHERWISE SPECIFIED  
REMOVE BURRS.  
BREAK EDGES.  
DIMENSIONS APPLY AFTER PLATING.

MATERIAL:  
**6061 Alloy**  
FINISH:  
**NA**

TITLE:  
**FAN COLLET - TEK 2465 O-SCOPE**

PART NUMBER:  
**NA**

REVISION:  
**00**

STATUS:  
**NOT SUBMITTED**

UNITS:  
**INCHES**

SCALE:  
**4:1**

SIZE:  
**B**

FILE NAME:  
**Fan Collet - Tek 2465 O-scope**

SHEET:  
**SHEET 1 OF 2**

**NOTES:**

1. BREAK ALL EDGES.
2. SHEET 1 IS ENGLISH UNITS, SHEET 2 IS SI UNITS.
3. CUT THREADS WITH LATHE TO GET THREAD DEPTH.

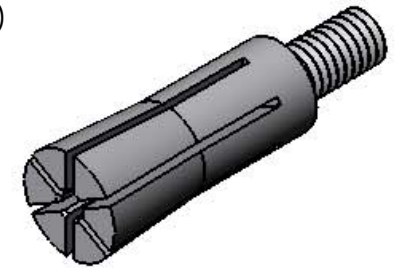
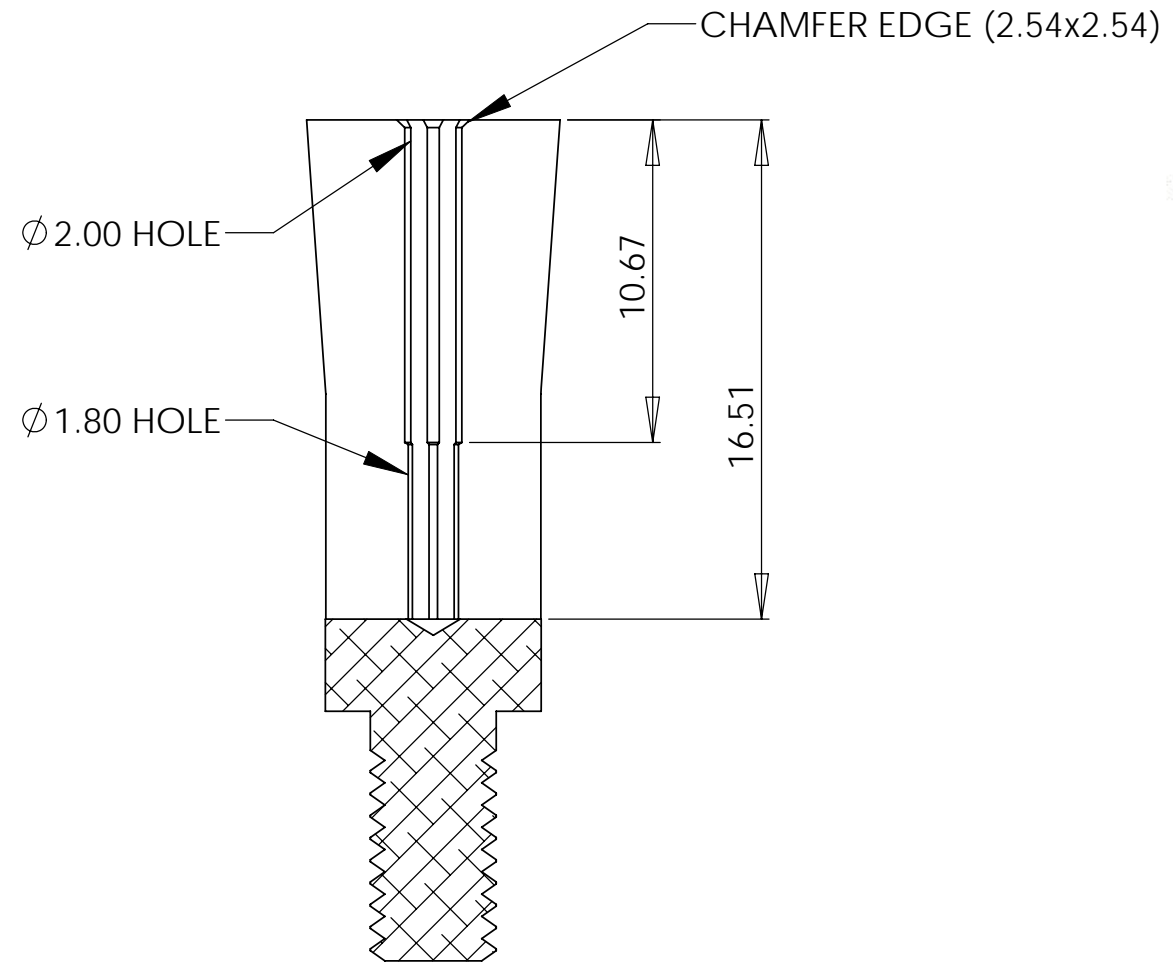
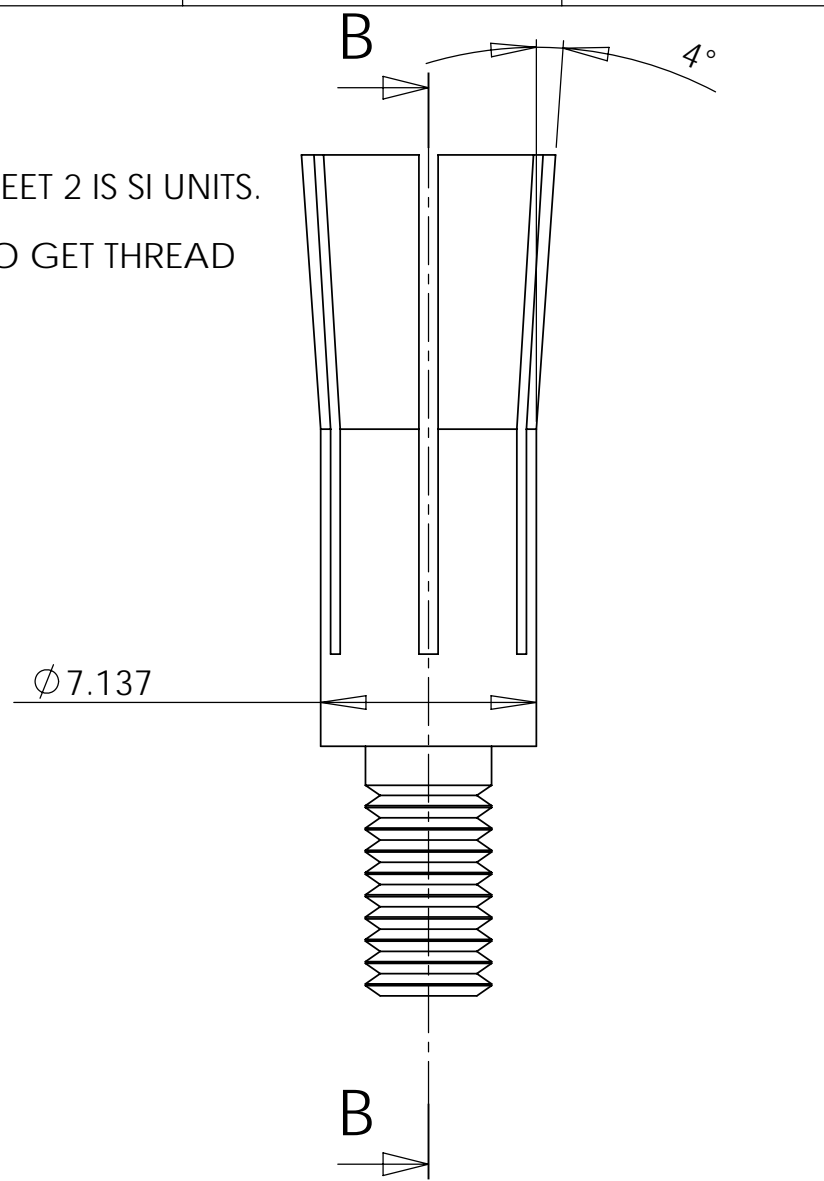

**SECTION B-B**

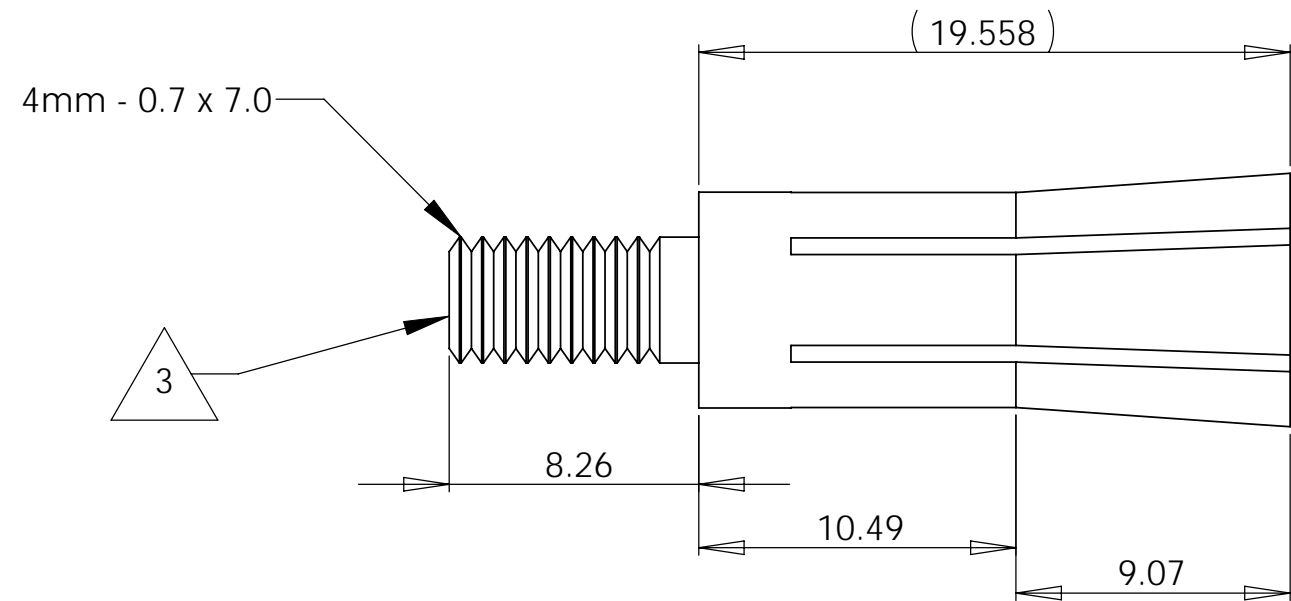
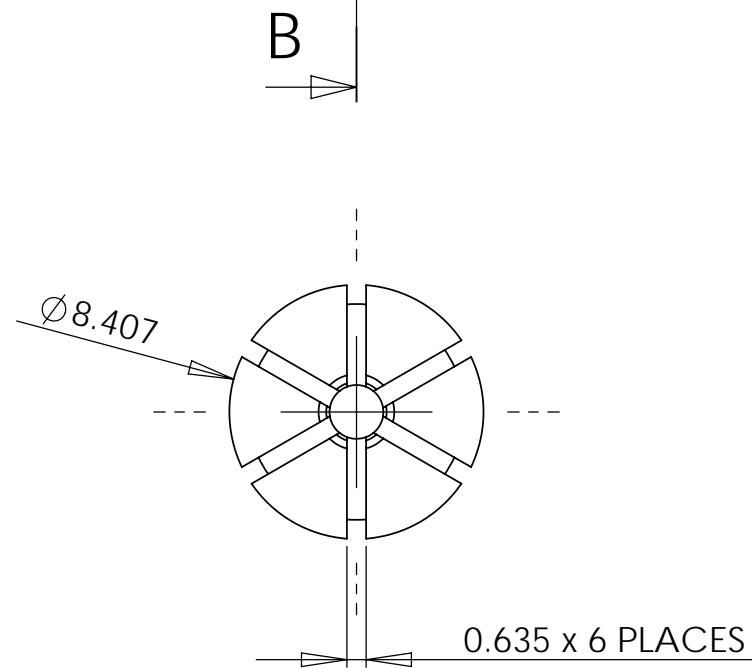

**PROPRIETARY AND CONFIDENTIAL**  
THE INFORMATION CONTAINED IN THIS DRAWING IS THE SOLE PROPERTY OF THE SPECTRANETICS CORPORATION. ANY REPRODUCTION IN PART OR AS A WHOLE WITHOUT WRITTEN PERMISSION IS PROHIBITED.

TOLERANCES:  
X.X ±0.050  
X.XX ±0.010  
X.XXX ±0.005  
X° ±0.5°

UNLESS OTHERWISE SPECIFIED  
REMOVE BURRS.  
BREAK EDGES.  
DIMENSIONS APPLY AFTER PLATING.

MATERIAL:  
**6061 Alloy**  
FINISH:  
**NA**

TITLE:  
**FAN COLLET - TEK 2465 O-SCOPE**

PART NUMBER:  
**NA**

REVISION:  
**00**

STATUS:  
**NOT SUBMITTED**

UNITS:  
**MM**

SCALE:  
**4:1**

SIZE:  
**B**

FILE NAME:  
**Fan Collet - Tek 2465 O-scope**

SHEET:  
**SHEET 2 OF 2**