

TEKTRONIX®

432
OSCILLOSCOPE

INSTRUCTION MANUAL

INSTRUCTION MANUAL

Serial Number _____

Narrow 06284

BEFORE READING

GOOD

PLEASE CHECK FOR CHANGE INFORMATION
AT THE REAR OF THIS MANUAL.

THIS MANUAL REPRINTED MAY 1974

432 OSCILLOSCOPE

WARRANTY

All Tektronix instruments are warranted against defective materials and workmanship for one year.

Any questions with respect to the warranty, mentioned above, should be taken up with your Tektronix Field Engineer or representative.

All requests for repairs and replacement parts should be directed to the Tektronix Field Office or representative in your area. This procedure will assure you the fastest possible service. Please include the instrument Type (or Part Number) and Serial or Model Number with all requests for parts or service.

Specifications and price change privileges reserved.

Copyright © 1971 by Tektronix, Inc., Beaverton, Oregon. Printed in the United States of America. All rights reserved. Contents of this publication may not be reproduced in any form without permission of the copyright owner.

U.S.A. and foreign Tektronix products covered by U.S. and foreign patents and/or patents pending.

TABLE OF CONTENTS

SECTION 1	432 SPECIFICATION	Page	SECTION 2	OPERATING INSTRUCTIONS (cont)	Page
	Introduction	1-1		Input Coupling	2-7
	Table 1-1 Electrical			Deflection Factor	2-8
	Vertical Deflection System	1-1		Dual-Trace Operation	2-8
	Triggering	1-3		Algebraic Addition	2-8
	Horizontal Deflection System	1-4		Trigger Source	2-9
	Calibrator	1-5		Trigger Coupling	2-9
	Z Axis Input	1-5		Trigger Slope	2-10
	Power Source	1-5		Trigger Level	2-10
	Display	1-5		Sweep Mode	2-10
	Table 1-2 Environmental	1-6		Horizontal Sweep Rates	2-10
	Table 1-3 Physical	1-7		Sweep Magnification	2-12
				Horizontal Position Control	2-12
				External Horizontal Input	2-12
				Intensity Modulation	2-12
				Calibrator	2-12
				Simplified Operating Instructions	
				General	2-12
				Normal Sweep Display	2-12
				Magnified Sweep Display	2-13
				External Horizontal Display	2-13
				Applications	
				General	2-13
				Peak-To-Peak Voltage	
				Measurements—AC	2-14
				Instantaneous Voltage	
				Measurements—DC	2-14
				Comparison Measurements	2-15
				Time Duration Measurements	2-17
				Determining Frequency	2-17
				Risetime Measurements	2-18
				Time Difference Measurements	2-18
				Multi-Trace Phase Difference	
				Measurements	2-19
				High Resolution Phase	
				Measurements	2-20
				Common-Mode Rejection	2-21
SECTION 2	OPERATING INSTRUCTIONS				
	General	2-1			
	Operating Voltage	2-1			
	Operating Temperature	2-1			
	Operating Position	2-1			
	Rackmounting	2-2			
	Controls and Connectors				
	General	2-2			
	General Operating Information				
	Intensity Control	2-5			
	Astigmatism Adjustment	2-5			
	Trace Alignment Adjustment	2-5			
	Graticule	2-5			
	Light Filter	2-5			
	Beam Finder	2-6			
	Bandwidth Limiter	2-6			
	Vertical Channel Selection	2-6			
	Vertical Gain Adjustment	2-7			
	Step Attenuator Balance				
	Adjustment	2-7			
	Signal Connections	2-7			
	Loading Effect of 432	2-7			
	Ground Considerations	2-7			

CONTENTS (cont)

SECTION 3	CIRCUIT DESCRIPTION	Page	SECTION 5	CALIBRATION	Page
	Introduction	3-1		Introduction	5-1
	Block Diagram			Tektronix Field Service	5-1
	General	3-1		Using This Procedure	5-1
	Circuit Operation			Test Equipment Required	
	General	3-3		General	5-1
	Channel 1 Input Amp And Preamp	3-3		Special Calibration Fixtures	5-1
	Channel 2 Input Amp And Preamp	3-5		Calibration Equipment	
	Channel Switch	3-6		Alternatives	5-1
	Vertical Output Amplifier	3-9		Test Equipment	5-2
	Trigger Pickoff And Generator	3-10		Index to Calibration Procedure	5-4
	Sweep Generator	3-13		Preliminary Procedure for	
	Horizontal Amplifier	3-16		Complete Calibration	5-4
	Power Supply Primary	3-18		Preliminary Control Settings	5-5
	Power Supply Secondary	3-21		Power Supply And Display	5-6
	CRT Circuit	3-21		Vertical System Adjustment	5-11
	Calibrator	3-24		Trigger Circuit Adjustment	5-18
				Horizontal System Calibration	5-21
				Calibrator Circuit Adjustment	5-24
SECTION 4	MAINTENANCE		SECTION 6	RACKMOUNTING	
	Introduction	4-1		Introduction	6-1
	Cabinet Removal	4-1		Rack Dimensions	6-1
	Preventive Maintenance			Mounting Procedure	6-1
	General	4-1		Portable Conversion	6-2
	Cleaning	4-1		Rear Panel Signal Connections	6-2
	Lubrication	4-2			
	Transistor Checks	4-2		SECTION 7	ELECTRICAL PARTS LIST
	Recalibration	4-2		Abbreviations and Symbols	
	Troubleshooting			Parts Ordering Information	
	Introduction	4-2		Index of Electrical Parts List	
	Troubleshooting Aids	4-2		Electrical Parts List	
	Troubleshooting Equipment	4-4			
	Troubleshooting Techniques	4-4		SECTION 8	DIAGRAMS AND CIRCUIT BOARD ILLUSTRATIONS
	Corrective Maintenance			Symbols and Reference Designators	8-1
	General	4-8		Voltage and Waveform Test	
	Obtaining Replacement Parts	4-8		Conditions	8-2
	Soldering Techniques	4-8		Diagrams	
	Component Replacement	4-9		Circuit Board Illustrations	
	Recalibration After Repair	4-11			
	Instrument Repackaging	4-11			

CONTENTS (cont)

SECTION 9 MECHANICAL PARTS LIST

Mechanical Parts List Information
Index of Mechanical Parts List and
Illustrations
Mechanical Parts List

CHANGE INFORMATION

Abbreviations and symbols used in this manual are based on or taken directly from IEEE Standard 260 "Standard Symbols for Units", MIL-STD-12B and other standards of the electronics industry. Change information, if any, is located at the rear of this manual.

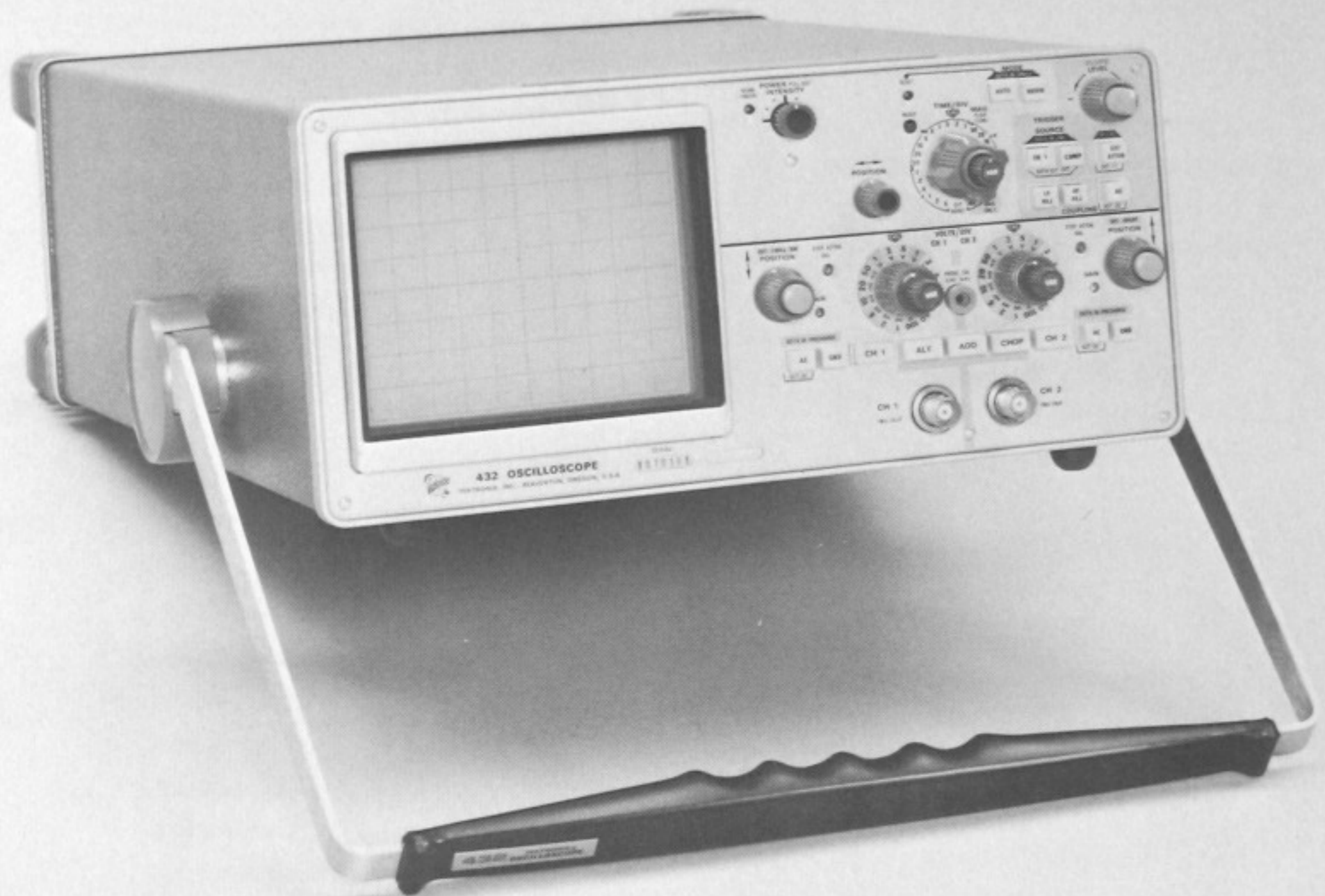

Fig. 1-1. 432 Oscilloscope.

SECTION 1 432 SPECIFICATION

Change information, if any, affecting this section will be found at the rear of this manual.

Introduction

The Tektronix 432 Oscilloscope is a solid-state portable instrument that combines small size and light weight with the ability to make precision waveform measurements. The instrument is mechanically designed to withstand the shock, vibration, and other extremes of environment associated with portability. The dual-channel DC-to-25 megahertz vertical system provides calibrated deflection factors from 1 millivolt to 10 volts/division. The trigger circuits provide stable triggering over the full range of vertical frequency response. The horizontal deflection system provides calibrated sweep rates from 5 seconds to 0.2 microsecond/division. A push-to-turn direct-reading six-position magnifier allows sweep magnification up to a maximum of 50 times and provides a maximum sweep rate of 0.02 microsecond/division. X-Y measurements can be made by applying the vertical (Y) signal to one of the vertical input connectors (appropriate vertical mode of operation selected) and the horizontal (X) signal to the EXT HORIZ connector on the rear panel (TIME/DIV switch set to EXT HORIZ). The regulated low-voltage power supply assures that instrument performance is not affected by variations in

line voltage and frequency. A new design light-weight, high efficiency power supply used in the 432 permits instrument operation over a wide range of line voltages and frequencies without line voltage range selection.

Information given in this instruction manual applies to the R432 also unless otherwise indicated. The R432 is electrically identical to the 432, but is adapted for mounting in a standard 19-inch rack. Rackmounting instructions and a dimensional drawing for the R432 are provided in section 6 of this manual.

The electrical characteristics which follow are divided into two categories. Characteristics listed in the Performance Requirement column are instrument specifications. Data in the Supplemental Information column does not constitute instrument specifications and is provided for reference use only. The following electrical characteristics apply over an ambient temperature range of -15°C to $+55^{\circ}\text{C}$, except as otherwise indicated. Warm-up time for given accuracy is 30 minutes.

**TABLE 1-1
ELECTRICAL**

Characteristic	Performance Requirement	Supplemental Information
VERTICAL DEFLECTION SYSTEM		
Deflection Factor		
Channel 1 or 2 calibrated range		
Without probe	1 mV to 10 V/div in 13 steps. Steps in a 1-2-5 sequence.	
With 10X probe	10 mV to 100 V/div in 13 steps. Steps in a 1-2-5 sequence.	
Accuracy	Within 3% of indicated deflection.	
Uncalibrated (VAR) range	Provides continuously variable deflection factors between the calibrated steps. Extends maximum uncalibrated deflection factor to at least 25 volts/division.	Each deflection factor increased by a factor of at least 2.5:1.
Frequency Response		
Upper -3 dB Frequency AC or DC Coupled		Bandwidth measured with 6 division reference, vertically centered. VAR V/DIV in Calibrated position.

TABLE 1-1 (cont)

Characteristic	Performance Requirement		Supplemental Information	
	-15°C to +30°C	+30°C to +55°C		
Frequency Response (cont)				
6 Division Reference				
With Standard X10 Probe or from 25 Ω Source	At least 25 MHz at 10 mV/DIV to 10 V/DIV, decreasing to 18 MHz at 1 mV/DIV.	At least 22 MHz at 10 mV/DIV to 10 V/DIV, decreasing to 16 MHz at 1 mV/DIV.		
Without Probe or from 25 Ω Source				
			-15°C to +30°C	+30°C to +55°C
			10 mV/DIV to 10 V/DIV	25 MHz
			5 mV/DIV	23 MHz
			2 mV/DIV	20 MHz
			1 mV/DIV	18 MHz
Lower -3 dB Frequency				
DC (Direct) Coupled	Within Gain Accuracy to DC.			
AC (Capacitive) Coupled				
X1 Probe or No Probe	10 Hz or less			
X10 Probe	1 Hz or less			
Step Response			6 Division Positive-going step, centered vertically, VAR V/DIV in Calibrated position.	
Risetime				
With Standard X10 Probe or from 25 Ω Source	14 ns or less 10 mV/DIV to 10 V/DIV, increasing to 19.5 ns or less at 1 mV/DIV.	16 ns or less 10 mV/DIV to 10 V/DIV, increasing to 22 ns or less at 1 mV/DIV.		
Without Probe, from 25 Ω Source				
			10 mV/DIV to 10 V/DIV	-15°C to +30°C
			5 mV/DIV	14.0 ns or less
			2 mV/DIV	15.2 ns or less
			1 mV/DIV	17.5 ns or less
				19.5 ns or less
Input RC Characteristics				
Resistance	1 megohm within 2%.			
Capacitance	Approximately 24 picofarads.			
Vertical Display Modes	Channel 1 only Channel 2 only Dual-Trace, alternate between channels Dual-Trace, chop between channels Added algebraically			
Input Coupling Modes	AC (capacitive) coupled, DC (direct) coupled, or AC Pre-Charge.			

TABLE 1-1 (cont)

Characteristic	Performance Requirement	Supplemental Information
Maximum Safe Input Voltage		
DC Coupled		250 V (DC plus peak AC) 500 V peak to peak AC (1 kHz or less)
AC Coupled		500 V (DC plus peak AC) 500 V peak to peak AC (1 kHz or less)
Chopped Mode Rate	Approximately 100 kilohertz.	
Signal Delay (Delay Line)	Allows viewing leading edge of triggering waveform.	
Step Attenuator Balance		Adjustable for no trace shift when deflection factor is changed from 1 mV/DIV to 10 mV/DIV.
Polarity Inversion	Display signal from Channel 2 can be inverted.	

TRIGGERING

Trigger Source	Internal from Channel 1 only or from displayed channel(s). Internal from AC power source. External from signal applied to EXT TRIG INPUT connector. External from signal applied to EXT TRIG INPUT connector attenuated 10 times.	
Trigger Coupling	AC AC low-frequency reject High-frequency reject DC The combination of high-frequency reject and AC low-frequency reject.	
Coupling and Sensitivity		
Coupling	To 5 MHz	At 25 MHz
DC Internal	0.3 Div deflection	1 Div deflection
DC External	50 mV	175 mV
AC	Same as DC at 20 Hz and above, requirements increase below 20 Hz.	
AC LF REJ	Same as AC at 150 kHz and above, requirements increase below 150 kHz.	
AC HF REJ	Same as AC at 15 kHz and below, requirements increase above 15 kHz.	

TABLE 1-1 (cont)

Characteristic	Performance Requirement	Supplemental Information
External Input RC Characteristics Resistance		1 MΩ (within 2% at DC) NOTE: In LF REJ mode with 1:1 attenuation the 1 MΩ DC coupled is shunted by 100 kΩ AC coupled. Effective input resistance decreases with increasing frequency to approximately 100 kΩ at 20 kHz and above.
Capacitance		Approximately 100 picofarads 1:1. Approximately 70 picofarads 1:10.

HORIZONTAL DEFLECTION SYSTEM

Sweep Mode	<p>Normal—Stable display presented only with signals meeting limits specified in Fig. 1-2. No display presented in the absence of an adequate trigger signal.</p> <p>Automatic—Stable display presented only with signals meeting limits specified with signals meeting limits specified in Fig. 1-2. Presents a free-running trace in the absence of an adequate trigger signal.</p> <p>Single Sweep—Sweep Generator produces only one sweep when triggered. Further sweeps are locked out until RESET button is pressed.</p>		
Calibrated Sweep Rates (unmagnified)	0.2 microsecond to 5 seconds/division in 23 steps in a 1-2-5 sequence.		
Magnifier	Direct-reading, six position, push to turn switch with up to 50 times maximum magnification. Extends the fastest sweep rate to 20 nanoseconds/division.		
Sweep Time Accuracy +20°C to +30°C	Unmagnified	Magnified	Over full 10 displayed horizontal divisions. Exclude the following portions of the sweep when checking magnified timing: X2 magnification — first and last 0.5 div. X5 magnification — first and last one div. X10 magnification — first and last two div. X20 magnification — first and last five div. X50 magnification — first and last ten div.
	Within 3%	Within 4%	
-15°C to +55°C	Within 4%	Within 5%	

TABLE 1-1 (cont)

Characteristic	Performance Requirement	Supplemental Information
Uncalibrated (variable) Sweep Rates	Provides continuously variable sweep rates between the calibrated steps. Extends the slowest uncalibrated sweep rate to at least 12.5 seconds/division.	At least 2.5:1.
EXT HORIZ Input		
Resistance		Approximately 50 kilohms.
Sensitivity	≈0.5 volt/division	
Bandwidth		DC to 500 kHz (10 div reference signal).
CALIBRATOR		
	+20°C to +30°C	-15°C to +55°C
Output Voltage	0.6 volt within 1.0% open circuit	0.6 volt within 2.0% open circuit
Repetition Rate	1 kHz within 1.0%	1 kHz within 2.0%
Output Resistance		Approximately 575 ohms.
Z AXIS INPUT		
Sensitivity	Five volt peak to peak signal causes noticeable modulation at normal intensity.	Positive-going signal decreases intensity.
Usable Frequency Range	DC to 20 megahertz.	
Input Resistance		Approximately 50 kilohms.
POWER SOURCE		
Line Voltage and Frequency Range	Operates on all nominal voltages from 100 volts to 240 volts AC, 50 to 400 Hz. For direct current power source, absolute voltage limits are 105 V DC to 250 V DC, either polarity.	No range switching necessary.
Power Consumption	90 volt amperes or 55 watts maximum.	70 volt-amperes, 50 watts typical.
DISPLAY		
Graticule		
Type	Internal	
Area	Eight divisions vertical by 10 divisions horizontal. Each division equals one centimeter.	
Phosphor	Standard phosphor is P31.	P7 phosphor also available.
Beam Finder	Limits display within graticule area when pressed.	

TABLE 1-2
ENVIRONMENTAL

Characteristic	Performance Requirement	Supplemental Information
Temperature		
Operating	-15°C to +55°C	
Non-Operating	-55°C to +75°C	
Altitude		
Operating	To 15,000 feet	Maximum allowable operating temperature decreased by 1°C per 1000 feet from 5000 feet to 15,000 feet.
Non-Operating	To 50,000 feet.	
Humidity		
Operating and Non-Operating	Five cycles (120 hours) referenced to MIL-E-16400F.	
Vibration		
Operating and Non-Operating	15 minutes along each of the 3 major axes at a total displacement of 0.025 inch peak to peak (4 g's at 55 Hertz) with frequency varied from 10 to 55 to 10 Hertz in one minute sweeps. Hold for three minutes at 55 Hertz. All major resonances must be above 55 Hertz.	
Shock		
Operating and Non-Operating	30 g's, 1/2 sine, 11 milliseconds duration, two shocks per axis each direction for a total of 12 shocks.	
Transportation	Tested to National Safe Transit Committee procedure 1A with a 30 inch drop.	
Electromagnetic Interference Optional EMI mesh filter installed	As tested in MIL-I-6181D	
Radiated	150 kilohertz to one gigahertz with mesh filter installed.	Mesh filter reduces light output approximately 56%.
Conducted	150 kilohertz to 25 megahertz.	

**TABLE 1-3
PHYSICAL**

Characteristic	Performance Requirement
Construction	
Chassis	Aluminum alloy.
Panel	Aluminum alloy with anodized finish.
Cabinet	Blue vinyl-coated aluminum.
Circuit Boards	Glass-epoxy laminate or polyphenylene oxide.

TABLE 1-3 (cont)

Characteristic	Performance Requirement
Overall Dimensions	
Height	5.6 inches.
Width	13 inches including handle.
Depth	18.6 inches.
Weight (Including Panel Cover and Accessories)	20 pounds, 6 ounces.
Domestic Shipping Weight	30 pounds, 2 ounces.
Export-Packed Shipping Weight	35 pounds, 2 ounces.

SECTION 2

OPERATING INSTRUCTIONS

Change information, if any, affecting this section will be found at the rear of the manual.

General

To effectively use the 432 Oscilloscope, the operation and capabilities of the instrument must be known. This section describes the operation of front-panel controls, gives simplified and general operating information, and lists some basic applications for this instrument.

OPERATING VOLTAGE

General

The 432 can be operated on all nominal line voltages from 100 volts to 240 volts AC, 50 to 400 hertz. It can also be operated from a 100 volts to 250 volts DC power source. No range switching or selection is necessary.

CAUTION

This instrument is designed for operation from a power source with its neutral at or near earth (ground) potential (for both AC and DC power sources) with a separate safety-earth conductor. It is not intended for operation from two phases of a multi-phase AC system, or across the legs of a single-phase, three-wire AC system.

The 432 is designed to be used with a three-wire AC power system. If a three- to two-wire adapter is used to connect this instrument to a two-wire AC power system, be sure to connect the ground lead of the adapter to earth (ground). Failure to complete the ground system may allow the chassis of this instrument to be elevated above ground potential and pose a shock hazard.

When operating the instrument from an external DC power source, polarity of the external voltage is unimportant. Again, it is imperative to complete the ground system to prevent accidental elevation of the instrument chassis and resultant shock hazard.

Operating Temperature

The 432 requires very little air circulation for proper operation. A thermal cutout in the instrument provides thermal protection and disconnects the instrument power if

the internal temperature exceeds a safe operating level. Power is automatically restored when the temperature returns to a safe level.

The 432 can be operated where the ambient temperature is between -15°C and $+55^{\circ}\text{C}$. The maximum operating temperature must be derated 1°C for each 1000 feet of altitude above 5000 feet. This instrument can be stored in ambient temperatures between -55°C and $+75^{\circ}\text{C}$. After storage at temperatures beyond the operating limits, allow the chassis temperature to come within the operating limits before power is applied.

Operating Position

The handle of the 432 can be positioned for carrying or as a tilt-stand for the instrument. To position the handle, press in at both pivot points (see Fig. 2-1) and turn the handle to the desired position. Fourteen positions are provided for convenient carrying or viewing. The instrument can also be set on the rear feet for either operation or storage.

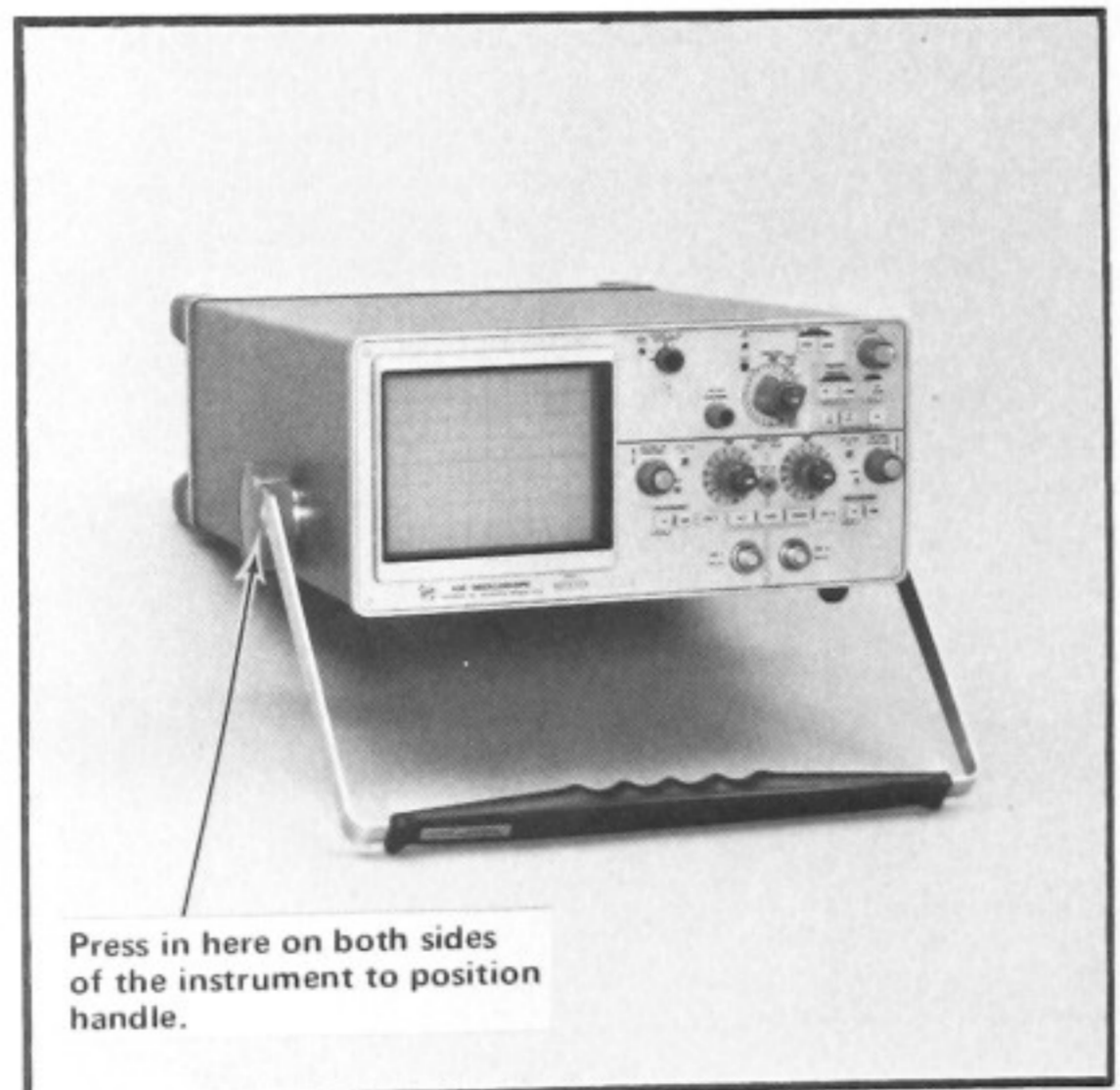

Fig. 2-1. Handle positioned to provide a stand for the instrument.

Rackmounting

Complete information for mounting the 432 in a cabinet rack is given in Section 6 of this manual.

CONTROLS AND CONNECTORS

General

A brief description of the function and operation of the instrument's controls and connectors follows. Fig. 2-2 shows the front and rear panels of the instrument. More detailed information is given in this section under General Operating Information.

Display

INTENSITY and POWER

A combination control that turns instrument power on or off (pull ON-push OFF) and also controls the brightness of the display.

BEAM FINDER

Compresses the display within the graticule area independently of display position or applied signals.

ASTIGmatism (Rear panel)

Adjusts CRT beam for optimum display definition.

TRACE ROTATION (Rear panel)

Screwdriver adjustment to align trace with horizontal graticule lines.

Vertical (both channels if applicable)

VOLTS/DIV

Selects vertical deflection factor in a 1-2-5 sequence (Variable control must be in the CAL position for indicated deflection).

Variable (Not labeled)

Provides continuously variable deflection factors between the calibrated settings of the VOLTS/DIV switch.

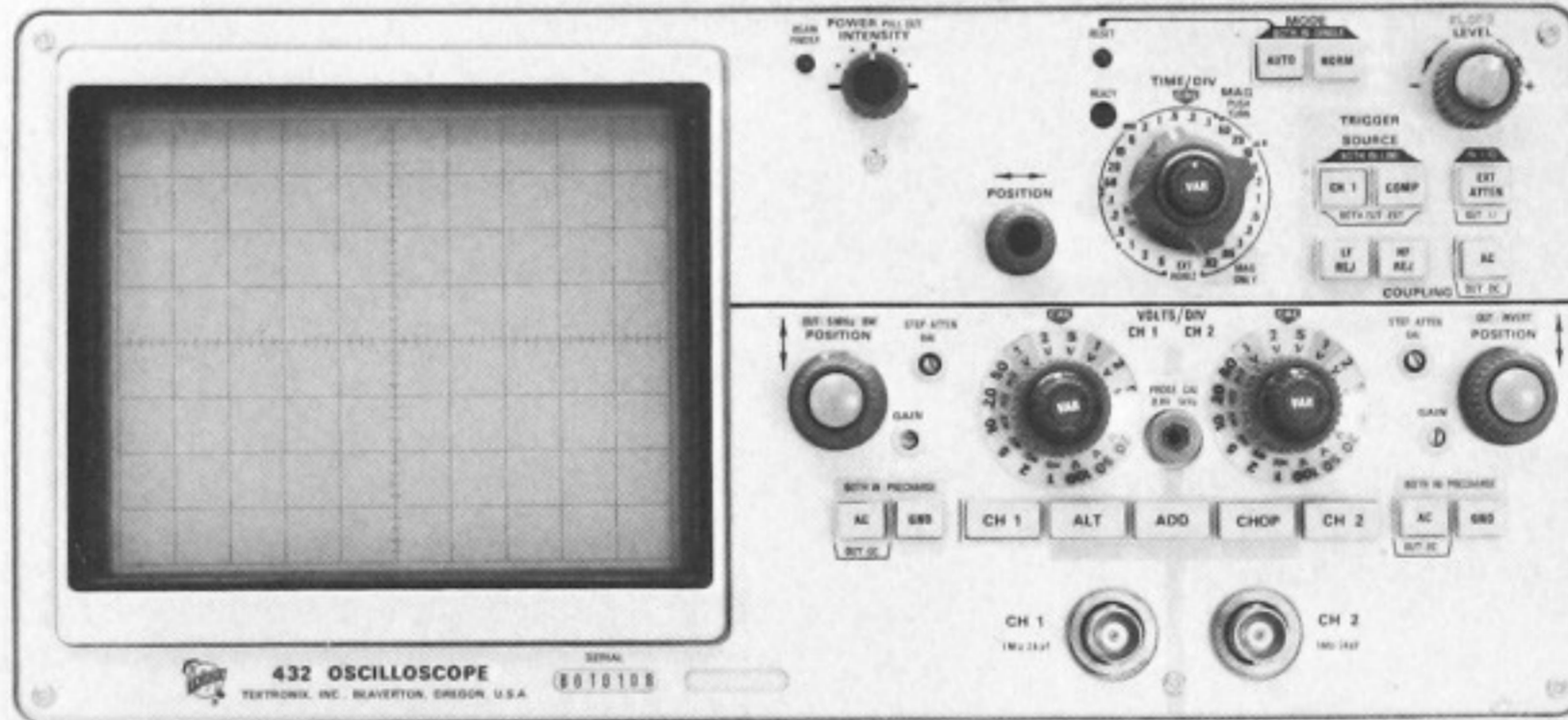

A. Front panel.

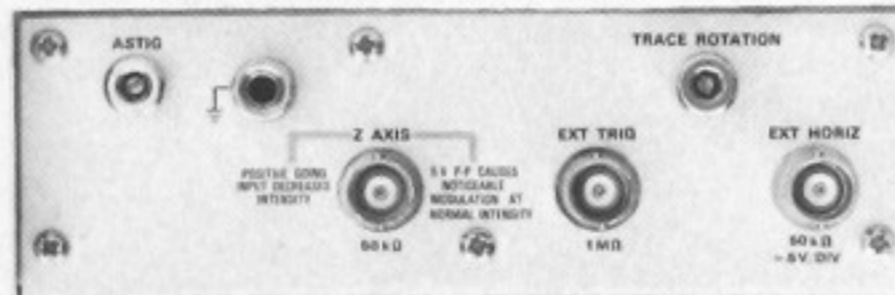

B. Rear panel.

Fig. 2-2. Front- and rear-panel controls and connectors.

POSITION	Controls the vertical position of the trace.
5 MHz BW	A push-push switch that limits the complete vertical amplifier system bandwidth to approximately 5 MHz.
INVERT (CH 2 only)	A push-push switch to invert the Channel 2 display.
GAIN	Screwdriver adjustment to set the gain of the vertical amplifier.
STEP ATTEN BAL	Screwdriver adjustment to balance the input amplifier in the 1 mV, 2 mV, 5 mV, and 10 mV positions of the VOLTS/DIV switches.
Input Coupling (AC/DC, GND)	<p>Selects method of coupling input signal to input amplifier.</p> <p>AC: In the AC position (button in) of this push-push switch, signals are capacitively coupled to the vertical amplifier. The DC component of the input signal is blocked. Low frequency -3 dB down point is about 10 hertz.</p> <p>DC: In the DC position (button out) of the AC push-push switch, all components of the input signal are passed to the input amplifier.</p> <p>GND: In the GND position (button in) of this push-push switch, the input of the vertical amplifier is disconnected from the input connector and grounded. Allows precharging of the input coupling capacitor.</p>
CH 1 and CH 2 Input	Input connectors that allow application of external signals to the inputs of the vertical amplifier. Includes a coding ring for probes with scale factor switching.
Mode (Not labeled)	<p>Selects mode of operation for vertical input amplifiers.</p> <p>CH 1: Displays Channel 1 only.</p> <p>ALT: Dual-trace display of signals on both channels. Display switched between channels at the end of each sweep.</p>

ADD: Signals applied to the CH 1 and CH 2 Input connectors are algebraically added and the algebraic sum is displayed on the CRT. The INVERT switch in Channel 2 allows the display to be CH 1 + CH 2 or CH 1 - CH 2.

CHOP: Dual-trace display of signals on both channels. Display switched at a repetition rate of approximately 100 kHz.

CH 2: Displays Channel 2 only.

Triggering

SOURCE	<p>Selects source of trigger signal.</p> <p>CH 1: A pushbutton switch that in the CH 1 position (button in) selects CH 1 as an internal trigger source.</p> <p>COMP: A pushbutton switch that in the COMP position (button in) allows the internal trigger source to be determined by the vertical mode of operation.</p> <p>LINE: When both the CH 1 and COMP switches are pressed in, a portion of the line frequency voltage is used as a trigger signal.</p> <p>EXT: When both the CH 1 and COMP switches are out, signals applied to the EXT TRIG connector are used for triggering.</p>
--------	---

EXT ATTEN In the 1:10 position (button in) of this push-push switch, external trigger signals are attenuated by a factor of 10. In the 1:1 position (button out) external trigger signals are not attenuated.

COUPLING Determines method of coupling trigger signal to trigger circuit.

AC: In the AC position (button in) of this push-push switch, DC is rejected and signals below about 20 hertz are attenuated. Accepts signals between about 20 hertz and 25 megahertz.

Operating Instructions—432

COUPLING (cont)	<p>DC: When both the AC and the LF REJ push-push switches are out, signals are directly coupled to the trigger circuit. Accepts all signals from DC to 25 megahertz if LF REJ and HF REJ are in out position.</p> <p>LF REJ: Rejects DC and attenuates signals below approximately 30 kilohertz. Accepts signals between about 30 kilohertz and 25 megahertz.</p> <p>HF REJ: Attenuates signals above approximately 50 kilohertz. Accepts signals between DC and approximately 50 kilohertz.</p>	<p>switch position can be reduced to at least the sweep rate of the next adjacent position to provide continuously variable sweep rates.</p>
		<p>Determines the operating mode for the sweep generator.</p>
		<p>AUTO: In the AUTO position (button in) of this pushbutton switch, the sweep is initiated by the applied trigger signal. In the absence of an adequate trigger signal, the sweep free runs and provides a bright reference trace.</p>
		<p>NORM: In the NORM position (button in) of this pushbutton switch, the sweep is initiated by the applied trigger signal. In the absence of an adequate trigger signal, there is no trace.</p>
		<p>SINGLE SWEEP: When both the AUTO and NORM switches are pressed in the sweep operates in the Single Sweep mode. After a sweep is displayed, further sweeps cannot be presented until the RESET button is pressed.</p>
		<p>When the RESET button is pressed (in the SINGLE SWEEP mode), a single display will be presented (with correct triggering). After the sweep is completed, the RESET button must be pressed again before another sweep can be displayed.</p>
LEVEL	<p>Selects the amplitude point on the trigger signal at which the sweep is triggered.</p>	
SLOPE	<p>Selects slope of trigger signal which starts the sweep.</p> <p>+: Sweep can be triggered from positive-going portion of trigger signal.</p> <p>-: Sweep can be triggered from negative-going portion of trigger signal.</p>	
EXT TRIG (Rear panel)	<p>Input connector for external trigger signals.</p>	
Sweep		
POSITION	<p>Controls horizontal position of the display.</p>	
TIME/DIV	<p>Selects the sweep rate of the sweep generator (Variable control must be in the CAL position for indicated sweep rate). Extreme counterclockwise position of switch selects External Horizontal mode of operation.</p>	
MAG	<p>Push-to-turn switch (concentric with TIME/DIV switch) provides sweep magnification up to a maximum of 50 times. Extends fastest sweep rate to 0.02 μs/div.</p>	
Variable (Not labeled)	<p>Provides uncalibrated sweep rates between the calibrated settings selected by the TIME/DIV switch. The sweep rate in each TIME/DIV</p>	
		MODE
		RESET
		READY LIGHT
		EXT HORIZ (Rear panel)
		Calibrator
		PROBE CAL 0.6 V 1 kHz
		Power and External Blanking
		POWER and INTENSITY
		<p>A combination control, part of which is a push-pull switch to</p>

Z AXIS (Rear panel) control application of power to the instrument.
 Input connector for external blanking signals.

GENERAL OPERATING INFORMATION

Intensity Control

The setting of the INTENSITY control should not affect the correct focus of the display. The focusing control is ganged to the INTENSITY control to provide automatic adjustment of display focus along with adjustment of display intensity. Maximum intensity is reached with the control advanced to approximately 3 o'clock. Further advancing the control overrides the blanking, thus in single-sweep operation, a spot can be obtained at the start of the sweep for vertical and horizontal beam location. For instruments with SN B060000 and up, a range is provided between the point of maximum intensity and blanking override. This allows the operator to adjust the intensity control within this range to improve the focus for single-sweep operation.

The light filter and optional EMI mesh filter reduce the observed light output from the CRT. When using these filters, avoid advancing the INTENSITY control to a setting that could cause phosphor damage. When the highest intensity display is desired, remove the filters. Apparent trace intensity can also be improved in such cases by reducing the ambient light or using a viewing hood.

Astigmatism Adjustment

If the CRT display is not well-defined, adjust the ASTIG (rear panel) as follows.

NOTE

The setting of the ASTIG adjustment should be correct for any display. However, fine adjustment of ASTIG for a specific INTENSITY setting may be desirable.

1. Connect the output of the PROBE CAL 0.6 V 1 kHz jack to either channel input and set the VOLTS/DIV switch of that channel to present a three-division display. Set the vertical MODE switch to display the channel selected.
2. Set the TIME/DIV switch to .5 ms.
3. Adjust the INTENSITY control to the desired setting.
4. Set the ASTIG adjustment so the horizontal and vertical portions of the display are as equally focused as possible.

Trace Alignment Adjustment

If a free-running trace is not parallel to the horizontal graticule line, set the TRACE ROTATION adjustment (rear panel) as follows. Position the trace to the center horizontal line. Adjust TRACE ROTATION so the trace is parallel with the horizontal graticule line.

Graticule

The graticule of the 432 is internally marked on the faceplate of the CRT to provide accurate, no-parallax measurements. The graticule is marked with eight vertical and 10 horizontal divisions. Each division is one centimeter square. In addition, each major division is divided into five minor divisions at the center vertical and horizontal lines. The vertical gain and horizontal timing are calibrated to the graticule so accurate measurements can be made from the CRT.

Fig. 2-3 shows the graticule of the 432 and defines the various measurement lines. The terminology defined here will be used in all discussions involving graticule measurements.

Light Filter

The tinted light filter provided minimizes light reflections from the face of the CRT to improve contrast when viewing the display under high ambient light conditions. The mesh filter (available as an optional accessory) provides shielding against radiated EMI (electro-magnetic interference) and also serves as a light filter. To remove either filter, press down at the bottom of the frame and pull the top of the filter away from the CRT faceplate (see Fig. 2-4).

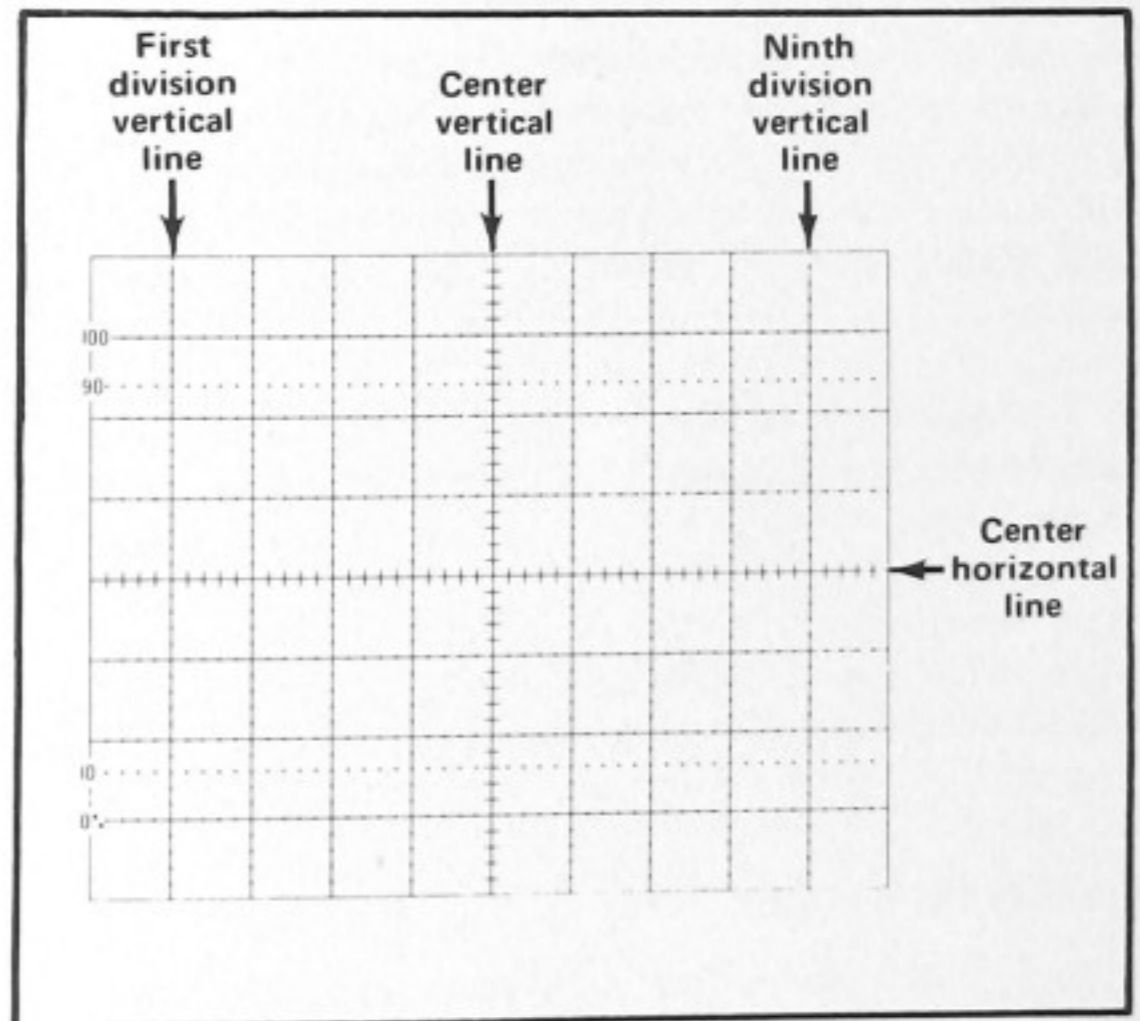

Fig. 2-3. Definition of measurement lines on 432 graticule.

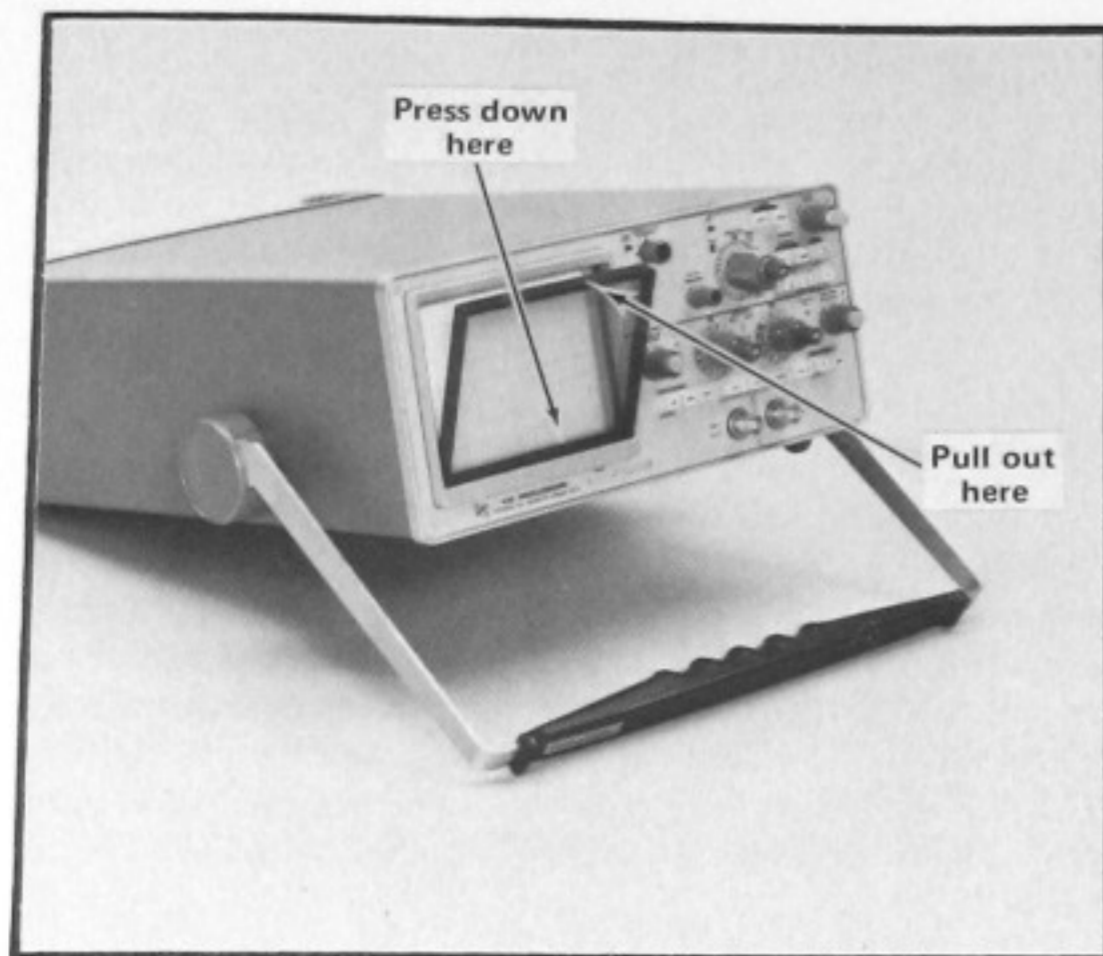

Fig. 2-4. Removing the filter.

Beam Finder

The BEAM FINDER switch provides a means of locating a display which overscans the viewing area either vertically or horizontally. When the BEAM FINDER pushbutton is pressed, the display is compressed within the graticule area. To locate and reposition an overscanned display, use the following procedure.

1. Press the BEAM FINDER button.
2. While the BEAM FINDER button is held in, increase the vertical deflection factor until the vertical deflection is reduced to about three divisions. The horizontal deflection needs to be reduced only in the EXT HORIZ mode of operation. This can only be accomplished by reducing the amplitude of the external horizontal signal applied to the EXT HORIZ input connector.
3. Adjust the vertical and horizontal POSITION controls to center the display about the vertical and horizontal center lines.
4. Release the BEAM FINDER button; the display should remain within the viewing area.

Bandwidth Limiter

The 5 MHz BW switch provides a method of reducing interference from unwanted high-frequency signals when viewing low-frequency signals. When set to the 5 MHz position (out), the upper -3 dB bandwidth point of the Verti-

cal Deflection system is limited to about five megahertz. Then unwanted high-frequency signals (such as television broadcast radiation interference) are reduced in the displayed waveform. Fig. 2-5 illustrates the use of this feature. The waveform in Fig. 2-5A is the display produced when a low-level, low-frequency signal is viewed in the presence of strong 50-megahertz radiation (switch pressed in). Fig. 2-5B shows the resultant CRT display when the high-frequency interference is reduced by setting the BW switch to the 5 MHz position (out).

Vertical Channel Selection

Either of the input channels can be used for single-trace displays. Apply the signal to the desired input connector and set the vertical mode switch to display the channel used. However, since CH 1 triggering is provided only in Channel 1 and the INVERT feature is provided only in Channel 2, the correct channel must be selected to take advantage of these features. For dual-trace displays, connect the signals to both input connectors and set the vertical mode switch to one of the dual-trace positions.

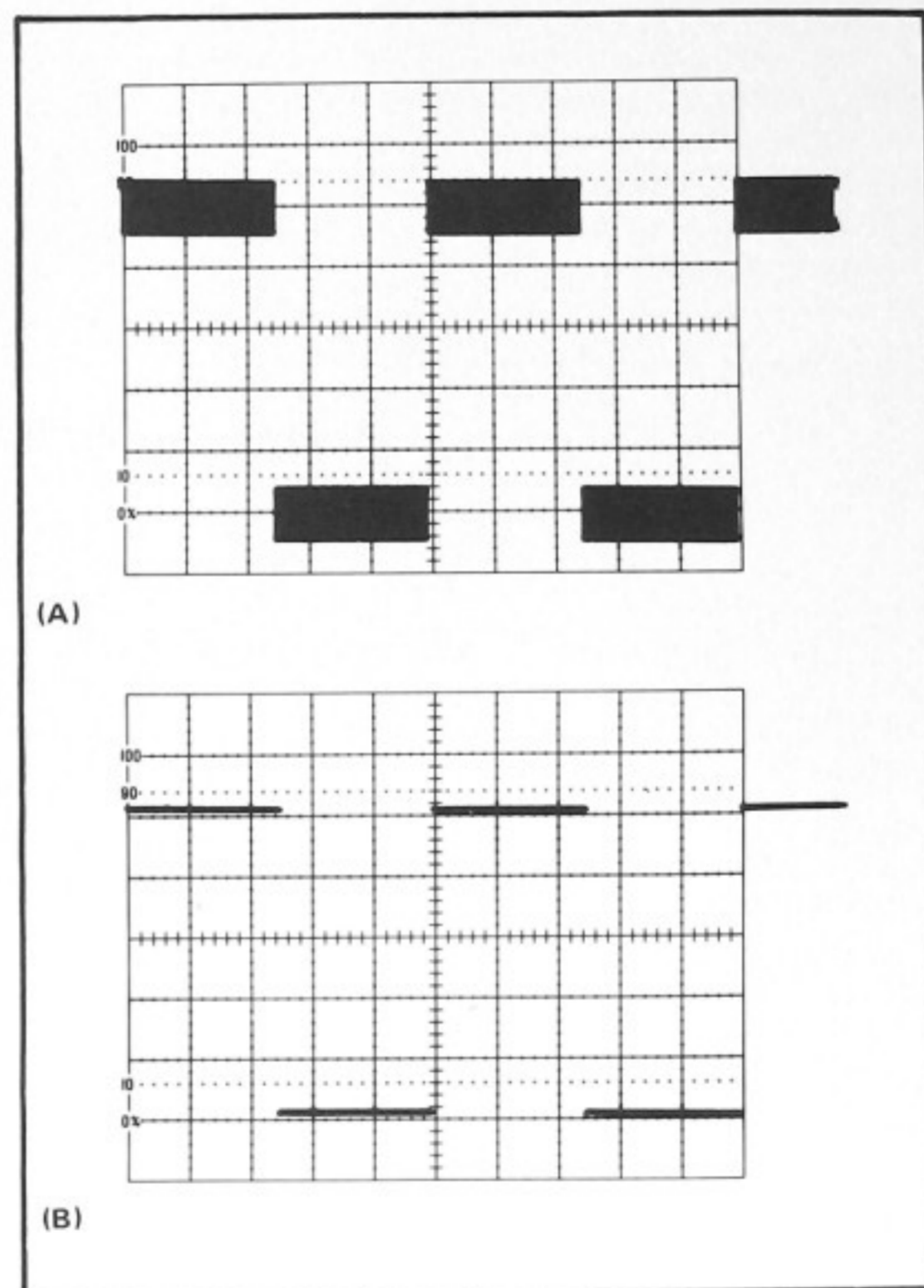

Fig. 2-5. (A) CRT display showing high-frequency interference when attempting to view low-level, low-frequency signal, (B) resultant display when 5 MHz BW switch is set to its out position.

Vertical Gain Adjustment

To check the gain of either channel, set the VOLTS/DIV switch to .1 and connect the PROBE CAL 0.6 V 1 kHz connector to the input connector of the channel used. The vertical deflection should be exactly six divisions. If not, adjust the front-panel GAIN adjustment for exactly six divisions of deflection.

NOTE

If the gain of the two channels must be closely matched (such as for ADD mode operation), the adjustment procedure given in the Calibration section should be used.

The best measurement accuracy when using probes is provided if the GAIN adjustment is made with the probes installed. Also, to provide the most accurate measurements, calibrate the vertical gain of the 432 at the temperature at which the measurement is to be made.

Step Attenuator Balance Adjustment

To check the step attenuator balance of either channel, set the Input Coupling to GND and the Sweep MODE switch to AUTO. Change the VOLTS/DIV switch from 10 mV to 1 mV. If the trace moves vertically, adjust the front-panel STEP ATT BAL adjustment as follows:

1. With the Input Coupling set to GND and the VOLTS/DIV switch set to 10 mV, move the trace to the center horizontal line of the graticule with the vertical POSITION control.
2. Set the VOLTS/DIV switch to 1 mV and adjust the STEP ATT BAL adjustment to return the trace to the center horizontal line.
3. Repeat steps 1 and 2 for minimum trace shift as the VOLTS/DIV switch is changed from 10 mV to 1 mV.

Signal Connections

In general, probes offer the most convenient means of connecting a signal to the input of the 432. Tektronix probes are shielded to prevent pickup of electrostatic interference. A 10X attenuator probe offers a high input impedance and allows the circuit under test to perform very close to normal operating conditions. However, a 10X probe also attenuates the input signal 10 times. A Tektronix field effect transistor probe offers the same high-input impedance as the 10X probes. However, it is particularly useful since it provides wide-band operation while presenting no attenuation (1X gain) and a low input capacitance. A standard 1X probe can be used for signal

connections, although it does not provide as high an input impedance and may result in a lower overall bandwidth. Specialized probes are also available from Tektronix, Inc. for high-voltage measurement, current measurement, etc. See the Tektronix, Inc. catalog for characteristics and compatibility of probes for use with this system.

In high-frequency applications requiring maximum overall bandwidth, use coaxial cables terminated in their characteristic impedances at the 432 input connectors. High-level, low-frequency signals can be connected directly to the 432 input connectors using short unshielded leads. This coupling method works best for signals below about one kilohertz and deflection factors above one volt/division. When this coupling method is used, establish a common ground between the 432 and the equipment under test. Attempt to position the leads away from any source of interference to avoid errors in the display. If interference is excessive with unshielded leads, use a coaxial cable or a probe.

Loading Effect of 432

As nearly as possible, simulate actual operating conditions in the equipment under test. Otherwise the equipment under test may not produce a normal signal. The 10X attenuator and field effect transistor probes mentioned previously offer the least circuit loading. See the probe instruction manual for loading characteristics of the probes.

When the signal is coupled directly to the input of the 432, the input impedance is about one megohm paralleled by about 24 pF. When the signal is coupled to the input through a coaxial cable, the effective input capacitance is increased. The actual input capacitance depends upon the type and length of cable used and the frequency of the signal.

Ground Considerations

Reliable signal measurements cannot be made unless both the oscilloscope and the unit under test are connected together by a common reference (ground) lead in addition to the signal lead or probe. Although the three-wire AC power cord provides a common connection when used with equipment with similar power cords, the ground loop produced may make accurate measurements impossible. The ground straps supplied with the probes provide an adequate ground. The shield of a coaxial cable provides a common ground when connected between two coaxial connectors (or with suitable adapters to provide a common ground). When using unshielded signal leads, a common ground lead should be connected from the 432 chassis to the chassis of the equipment under test.

Input Coupling

The Channel 1 and 2 Input Coupling switches allow a choice of input coupling methods. The type of display

Operating Instructions—432

desired and the applied signal will determine the coupling to use.

DC Coupling can be used for most applications. This position allows measurement of the DC component of a signal. It must also be used to display signals below about 100 hertz (10 hertz with a 10X probe) as they will be attenuated in the AC position.

With AC Coupling, the DC component of the signal is blocked by a capacitor in the input circuit. The low-frequency response in the AC position is about 10 hertz (−3 dB point). Therefore, some low-frequency attenuation can be expected near this frequency limit. Attenuation in the form of waveform tilt will also appear in square waves which have low-frequency components. AC coupling provides the best display of signals with a DC component which is much larger than the AC components.

The GND position provides a ground reference at the input of the 432 without the need to externally ground the input connectors. The signal applied to the input connector is internally disconnected, but not grounded, and the input circuit is held at ground potential. This also allows pre-charging the input coupling capacitor to prevent application of high-amplitude voltage spikes to the amplifier input.

Deflection Factor

The amount of vertical deflection produced by a signal is determined by the signal amplitude, the attenuation factor of the probe (if used), the setting of the VOLTS/DIV switch and the setting of the Variable VOLTS/DIV control. The calibrated deflection factors indicated by the VOLTS/DIV switches apply only when the Variable VOLTS/DIV control is set to the calibrated detent position.

The Variable VOLTS/DIV controls provide continuously variable (uncalibrated) vertical deflection factors between the calibrated settings of the VOLTS/DIV switches. The Variable control extends the maximum vertical deflection factor of the 432 to at least 25 volts/division (10 V position).

The 432 Oscilloscope features vertical deflection scale-factor switching. When probes having a scale-factor switching connector are used, the correct deflection factor can be read directly from the instrument front panel.

Dual-Trace Operation

Alternate Mode. The ALT position of the Vertical Mode switch produces a display which alternates between Channel 1 and 2 with each sweep of the CRT. Although the

ALT mode can be used at all sweep rates, the CHOP mode provides a more satisfactory display at sweep rates below about 0.5 millisecond/division. At these slow sweep rates, alternate mode switching becomes visually perceptible.

Proper internal triggering in the ALT mode can be obtained in either the COMP or the CH 1 position of the TRIGGER SOURCE switch. When in the COMP position, the sweep is triggered from the signal on each channel. This provides a stable display of two unrelated signals, but does not indicate the time relationship between the signals. In the CH 1 position, the two signals are displayed showing true time relationship. If the signals are not time related, the Channel 2 waveform will be unstable in the CH 1 SOURCE switch position.

Chopped Mode. The CHOP position of the Vertical Mode switch produces a display which is electronically switched between channels. In general, the CHOP MODE provides the best display at sweep rates slower than about 0.5 millisecond/division or whenever dual-trace, non-repetitive phenomena is to be displayed. At faster sweep rates the chopped switching becomes apparent and may interfere with the display.

Proper internal triggering for the CHOP mode is provided with the TRIGGER SOURCE switch set to CH 1. If the COMP position is used, the sweep circuits are triggered from the between-channel switching signal and both waveforms will be unstable. External triggering from a signal which is time-related to either signal provides the same result as CH 1 triggering.

Two signals which are time-related can be displayed in the chopped mode showing true time relationship. However, if the signals are not time-related, the Channel 2 display will appear unstable.

Two non-repetitive, transient or random signals occurring within the time interval determined by the TIME/DIV switch (10 times sweep rate) can be compared using the CHOP mode. To trigger the sweep correctly, the Channel 1 signal must precede the Channel 2 signal. Since the display shows true time relationship, time-difference measurements can be made.

Algebraic Addition

General. The ADD position of the Vertical Mode switch can be used to display the sum or difference of two signals, for common-mode rejection to remove an undesired signal, or for DC offset (applying a DC voltage to one channel to offset the DC component of a signal on the other channel).

Deflection Factor. The overall deflection in the ADD position of the vertical mode switch with both VOLTS/DIV switches set to the same position is the same as the deflection factor indicated by either VOLTS/DIV switch. The amplitude of an added mode display can be determined directly from the resultant CRT deflection, multiplied by the deflection factor indicated by either VOLTS/DIV switch. However, if the Channel 1 and 2 VOLTS/DIV switches are set to different deflection factors, the resultant voltage is difficult to determine from the CRT display. In this case, the voltage amplitude of the resultant display can be determined accurately only if the amplitude of the signal applied to either channel is known.

Precautions. The following general precautions should be observed when using the ADD mode.

1. Do not exceed the input voltage rating of the 432.
2. Do not apply signals that exceed an equivalent of about eight times the VOLTS/DIV switch setting. For example, with a VOLTS/DIV switch setting of .5, the voltage applied to that channel should not exceed about four volts. Larger voltages may distort the display.
3. Use Channel 1 and 2 POSITION control settings which most nearly position the signal of each channel to mid-screen when viewing in either the CH 1 or CH 2 positions of the Vertical Mode switch. This insures the greatest dynamic range for ADD mode operation.
4. For similar response from each channel, set the Channel 1 and 2 Input Coupling switches to the same position.

Trigger Source

COMP. In the COMP position of the TRIGGER SOURCE switch, the trigger signal is obtained from the displayed signal. This position provides the most convenient operation when displaying single channel displays. However, for dual-trace displays, special considerations must be made to provide the correct display. See Dual-Trace Operation in this section for dual-trace triggering information.

CH 1. The CH 1 position of the TRIGGER SOURCE switch provides a trigger signal from only the signal applied to the CH 1 connector. This position provides a stable display of the Channel 1 signal and is useful for certain dual-trace applications (see Dual-Trace Operation).

EXT. An external signal connected to the EXT TRIG connector can be used to trigger the sweep in the EXT

position of the TRIGGER SOURCE switch. The external signal must be time-related to the displayed signal to produce a stable display. An external trigger signal can be used to provide a triggered display when the internal signal is too low in amplitude for correct triggering, or contains signal components on which it is not desired to trigger. It is also useful when signal tracing in amplifiers, phase-shift networks, wave-shaping circuits, etc. The signal from a single point in the circuit can be connected to the EXT TRIG connector through a signal probe or cable. The sweep is then triggered by the same signal at all times and allows examination of amplitude, time relationship or wave-shape changes of signals at various points in the circuit without resetting the TRIGGER controls.

Trigger Coupling

Four methods of coupling the trigger signal to the trigger circuits can be selected with the TRIGGER COUPLING switch. Each position permits selection or rejection of the frequency components of the trigger signal which trigger the sweep.

AC. In the AC position of the TRIGGER COUPLING switch, the DC component of the trigger signal is blocked. Signals with low-frequency components below about 20 hertz are attenuated. In general, AC coupling can be used for most applications. However, if the signal contains unwanted low-frequency signals or if the sweep is to be triggered at a low-repetition rate or DC level, one of the remaining TRIGGER COUPLING switch positions will provide a better display.

The triggering point in the AC position depends upon the average voltage level of the trigger signals. If the trigger signals occur at random, the average voltage level will vary, causing the triggering point to vary also. This shift of the triggering point may be enough so it is impossible to maintain a stable display. In such cases, use DC coupling.

LF REJ. In the LF REJ position, DC is rejected and low-frequency signals below about 30 kilohertz are attenuated. Therefore, the sweep is triggered only by the higher-frequency components of the trigger signal. This position is particularly useful for providing stable triggering if the trigger signal contains line-frequency components. Also, in the ALT position of the vertical mode switch the LF REJ position provides the best display at fast sweep rates when comparing two unrelated signals (TRIGGER COUPLING switch set to COMP).

HF REJ. The HF REJ position passes all low-frequency signals between DC and about 50 kilohertz. Signals outside the above range are attenuated. When triggering from complex waveforms, this position is useful for providing stable display of the low-frequency components.

DC. DC coupling can be used to provide stable triggering with low-frequency signals which would be attenuated in the AC position, or with low repetition rate signals. It can also be used to trigger the sweep when the trigger signal reaches a DC level selected by the setting of the LEVEL control. When using internal triggering, the setting of the Channel 2 POSITION control affects the DC triggering point of a Channel 2 display (SOURCE switch in COMP position).

DC trigger coupling should not be used in the ALT dual-trace mode if the TRIGGER SOURCE switch is set to COMP. If used, the sweep will trigger on the DC level of one trace and then either lock out completely or free run on the other trace. Correct DC triggering for this mode can be obtained with the TRIGGER SOURCE switch set to CH 1.

With both the LF REJ and HF REJ buttons pushed in only those signals from approximately 30 kilohertz to 50 kilohertz will be passed to the Trigger Generator without being attenuated.

Trigger Slope

The TRIGGER SLOPE switch determines whether the trigger circuit responds to the positive-going or negative-going portion of the trigger signal. When the SLOPE switch is in the positive-going (+) position, the display starts with the positive-going portion of the waveform; in the negative-going (–) position, the display starts with the negative-going portion of the waveform (see Fig. 2-6). When several cycles of a signal appear in the display, the setting of the SLOPE switch is often unimportant. However, if only a certain portion of a cycle is to be displayed, the setting of the SLOPE switch is important to provide a display which starts on the desired slope of the input signal.

Trigger Level

The TRIGGER LEVEL control determines the voltage level on the triggering waveform at which the sweep is triggered. When the LEVEL control is set in the + region, the trigger circuit responds at a more positive point on the trigger signal. In the – region, the trigger circuit responds at a more negative point on the trigger signal. Fig. 2-6 illustrates this effect with different settings of the SLOPE switch.

To set the LEVEL control, first select the TRIGGER source, coupling, and slope. Then, set the LEVEL control fully counterclockwise and rotate it clockwise until the display starts at the desired point.

Sweep Mode

AUTO. The AUTO position of the Sweep MODE switch provides a triggered display when the LEVEL control is correctly set (see Trigger Level in this section) and an adequate trigger signal is available.

When the trigger repetition rate is less than about 10 hertz, or in the absence of an adequate trigger signal, the Sweep Generator free runs at the sweep rate selected by the TIME/DIV switch to produce a reference trace. When an adequate trigger signal is again applied, the free-running condition ends and the Sweep Generator is triggered to produce a stable display (with correct LEVEL control setting).

NORM. Operation in the NORM position of the Sweep MODE switch is the same as in the AUTO position when a trigger signal is applied. However, when no trigger signal is present, the Sweep Generator remains off and there is no display.

Use the NORM mode to display signals with repetition rates below about 10 hertz. This mode provides an indication of an adequate trigger signal as well as the correctness of trigger control settings, since there is no display without proper triggering.

SINGLE SWEEP. When the signal to be displayed is not repetitive or varies in amplitude, shape, or time, a conventional repetitive display may produce an unstable presentation. To avoid this, use the single-sweep feature of the 432. The SINGLE SWEEP mode can also be used to photograph a non-repetitive signal.

To use the SINGLE SWEEP mode, first make sure the trigger circuit will respond to the event to be displayed. Set the Sweep MODE switch to AUTO or NORM and obtain the best possible display in the normal manner (for random signals set the trigger circuit to trigger on a signal which is approximately the same amplitude and frequency as the random signal). Then, set the Sweep MODE to SINGLE SWEEP and press the RESET button. When the RESET button is pushed, the next trigger pulse initiates the sweep and a single trace will be presented on the screen. After this sweep is complete, the Sweep Generator is "locked out" until reset. The READY light is illuminated when the Sweep Generator has been reset and is ready to produce a sweep. To prepare the circuit for another single-sweep display, press the RESET button again.

Horizontal Sweep Rates

The TIME/DIV switch provides 23 calibrated unmagnified sweep rates ranging from 0.2 microsecond to 5

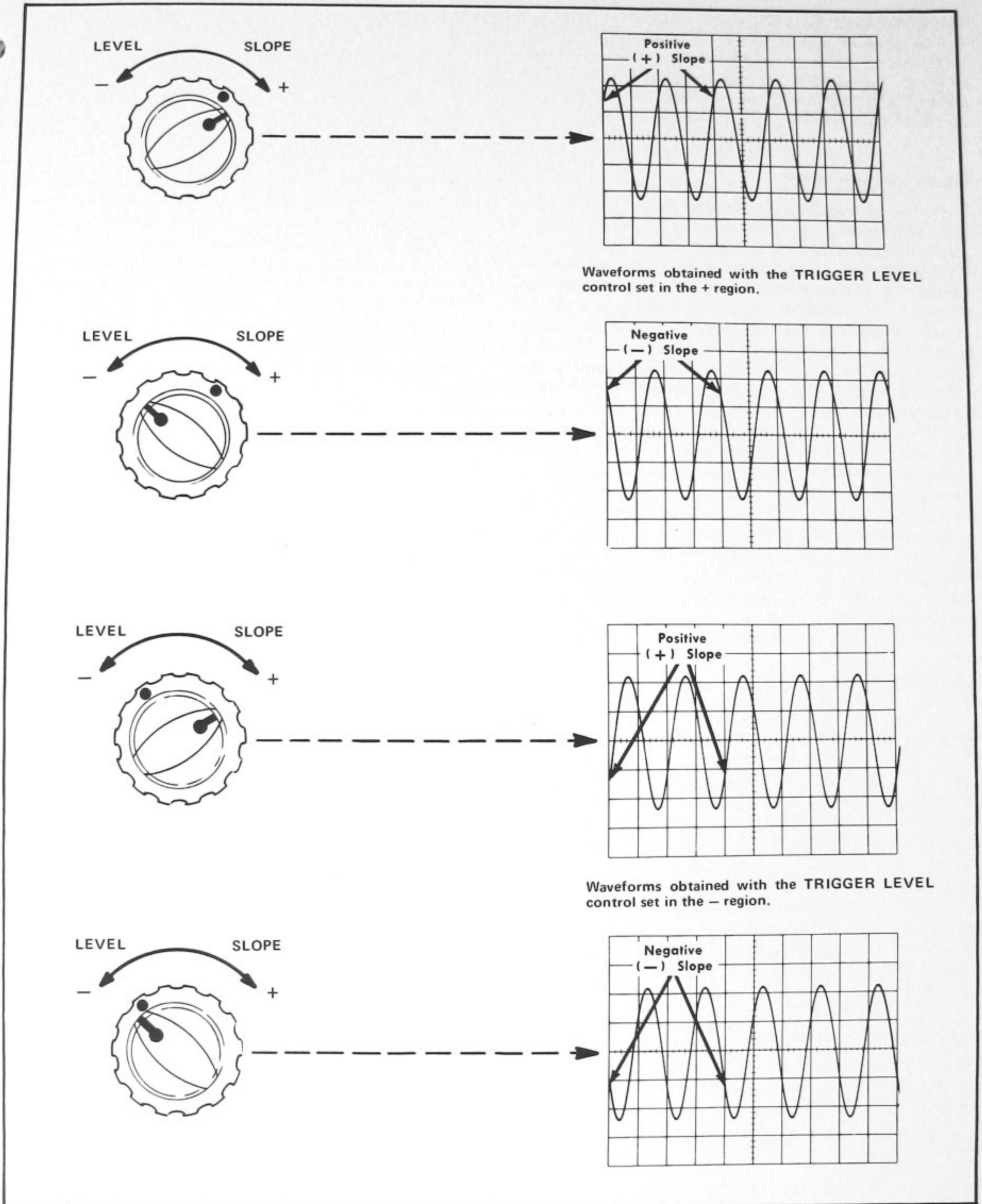

Fig. 2-6. Effect of the TRIGGER LEVEL control and SLOPE switch on the CRT display.

Operating Instructions—432

seconds/division. The three fastest indicated sweep rates can be achieved only by using sweep magnification. The VAR control provides continuously variable sweep rates between the settings of the TIME/DIV switch. The accuracy specifications for the calibrated sweep rates apply over the full ten horizontal divisions of deflection.

Sweep Magnification

The sweep magnifier expands the sweep up to a maximum of 50 times. The center part of the unmagnified display is the portion visible on the screen in magnified form. Equivalent length of the magnified sweep is ten divisions multiplied by the amount of magnification (500 divisions at 50 times magnification); any 10-division portion can be viewed by adjusting the horizontal POSITION control to bring the desired portion onto the viewing area. The dual-range feature of the horizontal POSITION control (see Horizontal Position Control discussion which follows) is particularly useful when the magnifier is on.

To use the magnified sweep, first position the portion of the unmagnified display to be expanded to the center of the graticule. Push in on the TIME/DIV knob and turn clockwise until the desired amount of magnification is achieved (up to a maximum of 50 times). The equivalent time/division is indicated directly by the TIME/DIV knob and is a calibrated sweep rate when the VAR control is in its calibrated detent.

Horizontal Position Control

The dual-range horizontal POSITION control used in the 432 provides a combination of coarse and fine adjustments in a single control. When this control is rotated, fine positioning is provided for a range of about 0.3 division for normal sweep, or about 15 divisions for magnified operation and the trace can be positioned precisely. Then, after the fine range is exceeded, the coarse adjustment comes into effect to provide rapid positioning of the trace. To use this control effectively for precise positioning, first turn the control to move the trace slightly beyond the desired position (coarse range). Then reverse the direction of rotation to use the fine range to establish the precise trace position desired.

External Horizontal Input

In some applications it is desirable to display one signal versus another signal rather than against time (internal sweep). The EXT HORIZ position of the TIME/DIV switch provides a means for applying an external signal to the horizontal amplifier for this type of display.

Connect the external horizontal signal to the EXT HORIZ connector. Deflection factor is approximately 0.5 volt/division. The X and Y channels of this instrument are

not time matched and some inherent phase shift is apparent. Take this inherent phase shift into account when making measurements. For aid in interpreting lissajous displays, refer to the reference books listed under Applications.

Intensity Modulation

Intensity (Z-axis) modulation can be used to relate a third item of electrical phenomena to the vertical (Y-axis) and the horizontal (X-axis) coordinates without changing the wave shape. A Z-axis modulating signal applied to the CRT circuit changes the intensity of the displayed waveform to provide this display. "Gray scale" intensity modulation can be obtained by applying signals which do not completely blank the display. Large amplitude signals of the correct polarity will completely blank the display; the sharpest display is provided by signals with a fast rise and fall. The voltage amplitude required for visible trace modulation depends on the setting of the INTENSITY control. At normal intensity level, a five-volt peak-to-peak signal produces a visible change in brightness.

Time markers applied to the Z AXIS input connector provide a direct time reference on the display. With uncalibrated horizontal sweep or X-Y mode operation, the time markers provide a means of reading time directly from the display. However, if the markers are not time-related to the displayed waveform, a single-sweep display should be used (for internal sweep only) to provide a stable display.

Calibrator

The internal calibrator of the 432 provides a convenient signal for checking vertical gain. The calibrator output signal available at the front-panel PROBE CAL 0.6 V 1 kHz jack is also very useful for checking and adjusting probe compensation as described in the probe instruction manual.

SIMPLIFIED OPERATING INSTRUCTIONS

General

The following operating instructions will allow calibrated measurements in most applications. The operator should be familiar with the complete function and operation of the instrument as described in this section before using this procedure.

Normal Sweep Display

1. Set the input coupling switches to AC, the Variable VOLTS/DIV controls to their detent positions, and the Vertical Mode switch to CH 1 (use ALT or CHOP for dual-trace display).

2. Set the sweep MODE switch to AUTO, the TRIGGER SLOPE switch to +, the TRIGGER COUPLING switch to AC, and the TRIGGER SOURCE switch to COMP.

3. Set the TIME/DIV switch to 1 mS/DIV and the VAR TIME/DIV control to its calibrated position.

4. Set the POWER switch to the on position and allow several minutes warmup.

5. Connect a signal to the CH 1 input connector.

6. Advance the INTENSITY control until the display is visible (if the display is not visible with the INTENSITY control at midrange, press the BEAM FINDER button and adjust the VOLTS/DIV switch until the display is reduced in size vertically; then center the compressed display with the vertical and horizontal POSITION controls; release the BEAM FINDER button).

7. Set the VOLTS/DIV switch and the vertical POSITION control for a display which remains within the display area vertically.

8. Set the TRIGGER LEVEL control for a stable display.

9. Set the TIME/DIV switch and the horizontal POSITION control for a display which remains within the display area horizontally.

Magnified Sweep Display

1. Follow steps 1-9 for normal sweep.

2. Adjust the horizontal POSITION control to move the area to be magnified to within the center horizontal division of the graticule. There should be equal amounts of the area of interest on either side of the center graticule line. If necessary, change the setting of the TIME/DIV switch and the POSITION control to obtain the desired display.

3. Push in and turn the VOLTS/DIV knob to achieve the desired amount of magnification. The position of the TIME/DIV knob indicates directly the magnified time/div. Adjust the horizontal POSITION control for precise positioning of the magnified display.

External Horizontal Display

1. Set the INTENSITY control fully counterclockwise.

2. Set the Input Coupling switches to AC and the variable volts/div controls to their detent positions.

3. Set the TIME/DIV switch to EXT HORIZ, the Vertical Mode switch to CH 1, and the Sweep MODE to AUTO.

4. Set the POWER switch to the on position and allow several minutes warmup.

5. Connect the X (horizontal) signal to the EXT HORIZ input connector on the instrument rear panel and the Y (vertical) signal to the CH 1 input connector.

6. Advance the INTENSITY control until the display is visible (if display is not visible, push the BEAM FINDER button and adjust the CH 1 VOLTS/DIV switch until the display is reduced in size vertically; the horizontal deflection can only be changed by changing the amplitude of the signal applied to the EXT HORIZ input connector (sensitivity is ≈ 0.5 volt/division); then center the compressed display with the CH 1 and the horizontal POSITION controls; release the BEAM FINDER button).

7. Adjust the CH 1 VOLTS/DIV switch and the amplitude of the external horizontal signal to obtain a display which remains within the display area.

APPLICATIONS

General

The following information describes the procedures and techniques for making basic measurements with a 432 Oscilloscope. These applications are not described in detail, since each application must be adapted to the requirements of the individual measurement. This instrument can also be used for many applications which are not described in this manual. Contact your local Tektronix Field Office or representative for assistance in making specific measurements with this instrument. Also, the following books describe oscilloscope measurement techniques which can be adapted for use with this instrument.

Harley Carter, "An Introduction to the Cathode Ray Oscilloscope", Phillips Technical Library, Cleaver-Hume Press Ltd., London, 1960.

J. Czech, "Oscilloscope Measuring Technique", Phillips Technical Library, Springer-Verlag, New York, 1965.

Robert G. Middleton and L. Donald Payne, "Using the Oscilloscope in Industrial Electronics", Howard W. Sams &

Operating Instructions—432

Co. Inc., The Bobbs-Merrill Company Inc., Indianapolis, 1961.

John F. Rider and Seymour D. Uslan, "Encyclopedia of Cathode-Ray Oscilloscopes and Their Uses", John F. Rider Publisher Inc., New York, 1959.

John F. Rider, "Obtaining and Interpreting Test Scope Traces", John F. Rider Publisher Inc., New York, 1959.

Rufus P. Turner, "Practical Oscilloscope Handbook", Volumes 1 and 2, John F. Rider Publisher Inc., New York, 1964.

Peak-to-Peak Voltage Measurements—AC

To make peak-to-peak voltage measurements, use the following procedure:

1. Apply the signal to either input connector.
2. Set the Vertical Mode switch to display the channel used.
3. Set the Input coupling switch to AC if the DC component is large enough to shift the display out of the graticule area.
4. Set the VOLTS/DIV switch to display about 3 to 8 divisions of waveform.

NOTE

For low-frequency signals below 100 Hz, the AC position causes some attenuation of the displayed waveform. Typical attenuation with a X1 probe or without a probe is 1 to 2% at 50 Hz, 20 to 25% at 10 Hz, and approximately 50% at 5 Hz. With a X10 probe, corresponding frequencies would be 5 Hz, 1 Hz, and 0.5 Hz, respectively.

5. Set the TRIGGERING controls to obtain a stable display. Set the TIME/DIV switch to a position that displays several cycles of the waveform.

6. Turn the vertical POSITION control so the lower portion of the waveform coincides with one of the graticule lines below the center horizontal line, and the top of the waveform is on the viewing area. With the horizontal POSITION control, move the display so one of the upper peaks lies near the center vertical line (see Fig. 2-7).

7. Measure the divisions of vertical deflection peak to peak. Make sure the Variable VOLTS/DIV control is in the CAL position.

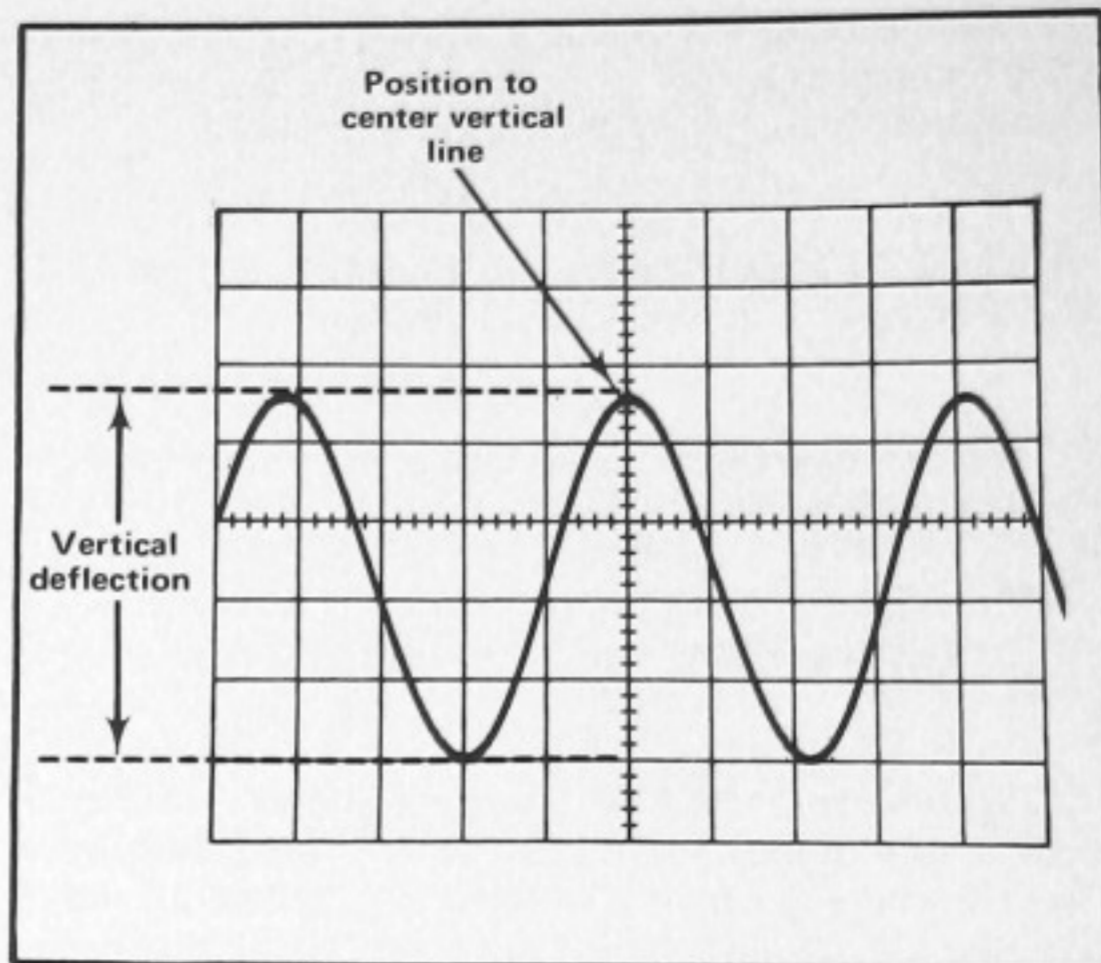

Fig. 2-7. Measuring peak-to-peak voltage of a waveform.

NOTE

This technique can also be used to make measurements between two points on the waveform, rather than peak to peak.

8. Multiply the distance measured in step 7 by the VOLTS/DIV switch setting. Also include the attenuation factor of the probe, if using a probe that does not have a scale-factor switching connector.

EXAMPLE. Assume that the peak-to-peak vertical deflection is 4.6 divisions (see Fig. 2-7) with a VOLTS/DIV switch setting of .5 V.

$$\text{Volts Peak to Peak} = \text{vertical deflection (divisions)} \times \text{VOLTS/DIV setting}$$

Substituting the given values:

$$\text{Volts Peak to Peak} = 4.6 \times 0.5 \text{ V}$$

The peak-to-peak voltage is 2.3 volts.

Instantaneous Voltage Measurements—DC

To measure the DC level at a given point on a waveform, use the following procedure:

1. Connect the signal to either input connector.
2. Set the Vertical Mode switch to display the channel used.

3. Set the VOLTS/DIV switch to display about six divisions of the waveform.
4. Set the Input Coupling switch to GND.
5. Set the TRIGGERING Mode switch to AUTO.
6. Position the trace to the bottom line of the graticule or other reference line. If the voltage is negative with respect to ground, position the trace to the top line of the graticule. Do not move the vertical POSITION control after this reference line has been established.

NOTE

To measure a voltage level with respect to a voltage other than ground, make the following changes in step 6. Set the Input Coupling switch to DC and apply the reference voltage to the INPUT connector. Then position the trace to the reference line.

7. Set the Input Coupling switch to DC. The ground reference line can be checked at any time by switching to the GND position.

8. Set the TRIGGERING controls to obtain a stable display. Set the TIME/DIV switch to a setting that displays several cycles of the signal.

9. Measure the distance in divisions between the reference line and the point on the waveform at which the DC level is to be measured. For example, in Fig. 2-8 the measurement is made between the reference line and point A.

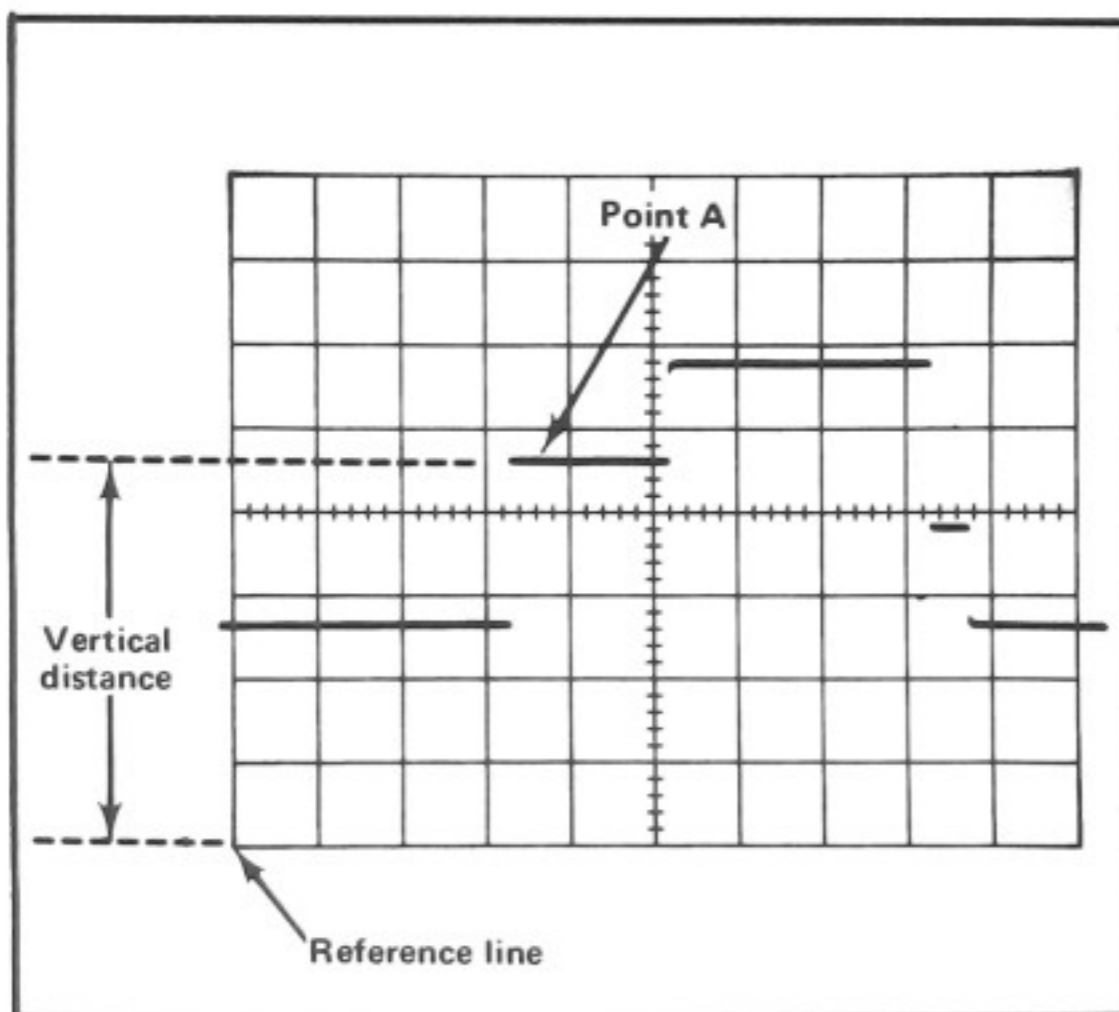

Fig. 2-8. Measuring instantaneous DC voltage with respect to A reference voltage.

10. Establish the polarity of the signal. If the waveform is above the reference line the voltage is positive; below the line, negative (with the INVERT switch in for Channel 2).

11. Multiply the distance measured in step 9 by the VOLTS/DIV switch setting. Include the attenuation factor of the probe, if using a probe that does not have a scale factor switching connector.

EXAMPLE. Assume that the vertical distance measured is 4.6 divisions (see Fig. 2-8) and the waveform is above the reference line with a VOLTS/DIV switch setting of 2 V.

Using the formula:

$$\text{Instantaneous Voltage} = \text{vertical distance (divisions)} \times \text{polarity} \times \text{VOLTS/DIV setting}$$

Substituting the given values:

$$\text{Instantaneous Voltage} = 4.6 \times +1 \times 2 \text{ V}$$

The instantaneous voltage is +9.2 volts.

Comparison Measurements

In some applications it may be desirable to establish arbitrary units of measurement other than those indicated by the VOLTS/DIV switch or TIME/DIV switch. This is particularly useful when comparing unknown signals to a reference amplitude or repetition rate. One use for the comparison-measurement technique is to facilitate calibration of equipment (e.g., on an assembly-line test) where the desired amplitude or repetition rate does not produce an exact number of divisions of deflection. The adjustment will be easier and more accurate if arbitrary units of measurement are established so that correct adjustment is indicated by an exact number of divisions of deflection. Arbitrary sweep rates can be useful for comparing harmonic signals to a fundamental frequency, or for comparing the repetition rate of the input and output pulses in a digital count-down circuit. The following procedure describes how to establish arbitrary units of measure for comparison measurements. Although the procedure for establishing vertical and horizontal arbitrary units of measurement is much the same, both processes are described in detail.

Vertical Deflection Factor. To establish an arbitrary vertical deflection factor based upon a specific reference amplitude, proceed as follows:

1. Connect the reference signal to the INPUT connector. Set the TIME/DIV switch to display several cycles of the signal.

Operating Instructions—432

2. Set the VOLTS/DIV switch and the Variable VOLTS/DIV control to produce a display an exact number of graticule divisions in amplitude. Do not change the Variable VOLTS/DIV control after obtaining the desired deflection. This display can be used as a reference for amplitude comparison measurements.

3. To establish an arbitrary vertical deflection factor so the amplitude of an unknown signal can be measured accurately at any setting of the VOLTS/DIV switch, the amplitude of the reference signal must be known. If it is not known, it can be measured before the Variable VOLTS/DIV control is set in step 2.

4. Divide the amplitude of the reference signal (volts) by the product of the vertical deflection established in step 2 (divisions) and the setting of the VOLTS/DIV switch. This is the vertical conversion factor.

$$\text{Vertical Conversion Factor} = \frac{\text{reference signal amplitude (volts)}}{\text{vertical deflection (divisions)} \times \text{VOLTS/DIV switch setting}}$$

5. To measure the amplitude of an unknown signal, disconnect the reference signal and connect the unknown signal to the input connector. Set the VOLTS/DIV switch to a setting that provides sufficient vertical deflection to make an accurate measurement. Do not readjust the Variable VOLTS/DIV control.

6. Measure the vertical deflection in divisions and calculate the amplitude of the unknown signal using the following formula:

$$\text{Signal Amplitude} = \text{VOLTS/DIV switch setting} \times \text{vertical conversion factor} \times \text{vertical deflection (divisions)}$$

EXAMPLE. Assume a reference signal amplitude of 30 volts, a VOLTS/DIV switch setting of 5 V, and the Variable VOLTS/DIV control is adjusted to provide a vertical deflection of four divisions.

Substituting these values in the vertical conversion factor formula (step 4):

$$\text{Vertical Conversion Factor} = \frac{30 \text{ V}}{4 \times 5 \text{ V}} = 1.5$$

Then, with a VOLTS/DIV switch setting of 10, the peak-to-peak amplitude of an unknown signal which produces a vertical deflection of five divisions can be determined by using the signal amplitude formula (step 6):

$$\text{Signal Amplitude} = 10 \text{ V} \times 1.5 \times 5 = 75 \text{ volts}$$

Sweep Rates. To establish an arbitrary horizontal sweep rate based upon a specific reference frequency, proceed as follows:

1. Connect the reference signal to the INPUT connector. Set the VOLTS/DIV switch for four or five divisions of vertical deflection.

2. Set the TIME/DIV switch and the Variable TIME/DIV control so one cycle of the signal covers an exact number of horizontal divisions. Do not change the Variable TIME/DIV control after obtaining the desired deflection. This display can be used as a reference for frequency comparison measurements.

3. To establish an arbitrary sweep rate so the repetition rate of an unknown signal can be measured accurately at any setting of the TIME/DIV switch, the repetition rate of the reference signal must be known. If it is not known, it can be measured before the Variable TIME/DIV control is set in step 2.

4. Divide the repetition rate of the reference signal (seconds) by the product of the horizontal deflection established in step 2 (divisions) and the setting of the TIME/DIV switch. This is the horizontal conversion factor.

$$\text{Horizontal Conversion Factor} = \frac{\text{reference signal repetition rate (seconds)}}{\text{horizontal deflection (divisions)} \times \text{TIME/DIV switch setting}}$$

5. To measure the repetition rate of an unknown signal, disconnect the reference signal and connect the unknown signal to the input connector. Set the TIME/DIV switch to a setting that provides sufficient horizontal deflection to make an accurate measurement. Do not readjust the Variable TIME/DIV control.

6. Measure the horizontal deflection in divisions and calculate the repetition rate of the unknown signal using the following formula:

$$\text{Repetition Rate} = \frac{\text{TIME/DIV switch setting}}{\text{horizontal conversion factor}} \times \text{horizontal deflection (divisions)}$$

EXAMPLE. Assume a reference signal frequency of 455 hertz (repetition rate 2.19 milliseconds), and a TIME/DIV switch setting of .2 ms, with the Variable TIME/DIV control adjusted to provide a horizontal deflection of eight divisions. Substituting these values in the horizontal conversion factor formula (step 4):

$$\text{Horizontal Conversion Factor} = \frac{2.19 \text{ milliseconds}}{.2 \times 8} = 1.37$$

Then, with a TIME/DIV switch setting of 50 μs, the repetition rate of an unknown signal which completes one cycle in seven horizontal divisions can be determined by using the repetition rate formula (step 6):

$$\text{Repetition Rate} = 50 \mu\text{s} \times 1.37 \times 7 = 480 \mu\text{s}$$

This answer can be converted to frequency by taking the reciprocal of the repetition rate (see application on Determining Frequency).

Time Duration Measurements

To measure time between two points on a waveform, use the following procedure:

1. Connect the signal to one of the input connectors.
2. Set the Vertical Mode switch to display the channel used.
3. Set the VOLTS/DIV switch to display about four divisions of the waveform.
4. Set the TRIGGERING controls to obtain a stable display.
5. Set the TIME/DIV switch to the fastest sweep rate that displays less than eight divisions between the time measurement points (see Fig. 2-9).
6. Adjust the vertical POSITION control to move the points between which the time measurement is made to the center horizontal line.

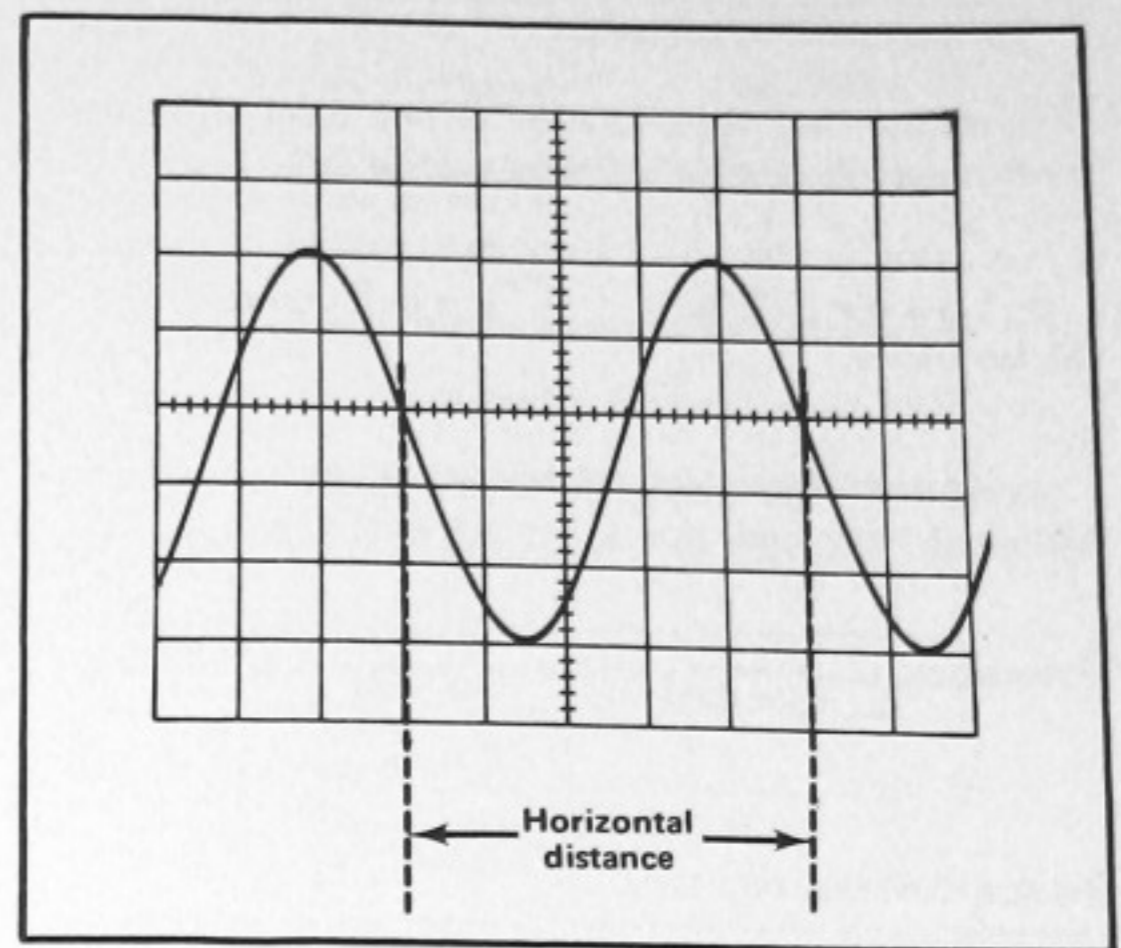

Fig. 2-9. Measuring time duration between points on a waveform.

7. Adjust the horizontal POSITION control to center the time-measurement points within the center eight divisions of the graticule.

8. Measure the horizontal distance between the time measurement points. Be sure the Variable TIME/DIV control is set to CAL.

9. Multiply the distance measured in step 8 by the setting of the TIME/DIV switch.

EXAMPLE. Assume that the horizontal distance between the time measurement points is five divisions (see Fig. 2-9) and the TIME/DIV switch is set to .1 ms.

Using the formula:

$$\text{Time Duration} = \frac{\text{horizontal distance (divisions)}}{\text{TIME/DIV setting}}$$

Substituting the given values:

$$\text{Time Duration} = 5 \times 0.1 \text{ ms}$$

The time duration is 0.5 millisecond.

Determining Frequency

The time measurement technique can also be used to determine the frequency of a signal. The frequency of a periodically recurrent signal is the reciprocal of the time duration (period) of one cycle.

Operating Instructions—432

Use the following procedure:

1. Measure the time duration of one cycle of the waveform as described in the previous application.
2. Take the reciprocal of the time duration to determine the frequency.

EXAMPLE. The frequency of the signal shown in Fig. 2-9, which has a time duration of 0.5 millisecond, is:

$$\text{Frequency} = \frac{1}{\text{time duration}} = \frac{1}{0.5 \text{ ms}} = 2 \text{ kHz}$$

Risetime Measurements

Risetime measurements employ basically the same techniques as time-duration measurements. The main difference is the points between which the measurement is made. The following procedure gives the basic method of measuring risetime between the 10% and 90% points of the waveform.

1. Connect the signal to either input connector.
2. Set the Vertical Mode switch to display the channel used.
3. Set the VOLTS/DIV switch and Variable control to produce a display exactly six divisions in amplitude.
4. Center the display about the center horizontal line with the vertical POSITION control.
5. Set the TRIGGERING controls to obtain a stable display.
6. Set the TIME/DIV switch to the fastest sweep rate that will display less than eight divisions between the 10% and 90% points on the waveform.

7. Adjust the horizontal POSITION control to move the 10% point of the waveform to the second vertical line of the graticule (see Fig. 2-10).

8. Measure the horizontal distance between the 10% and 90% points. Be sure the Variable TIME/DIV control is set to CAL.

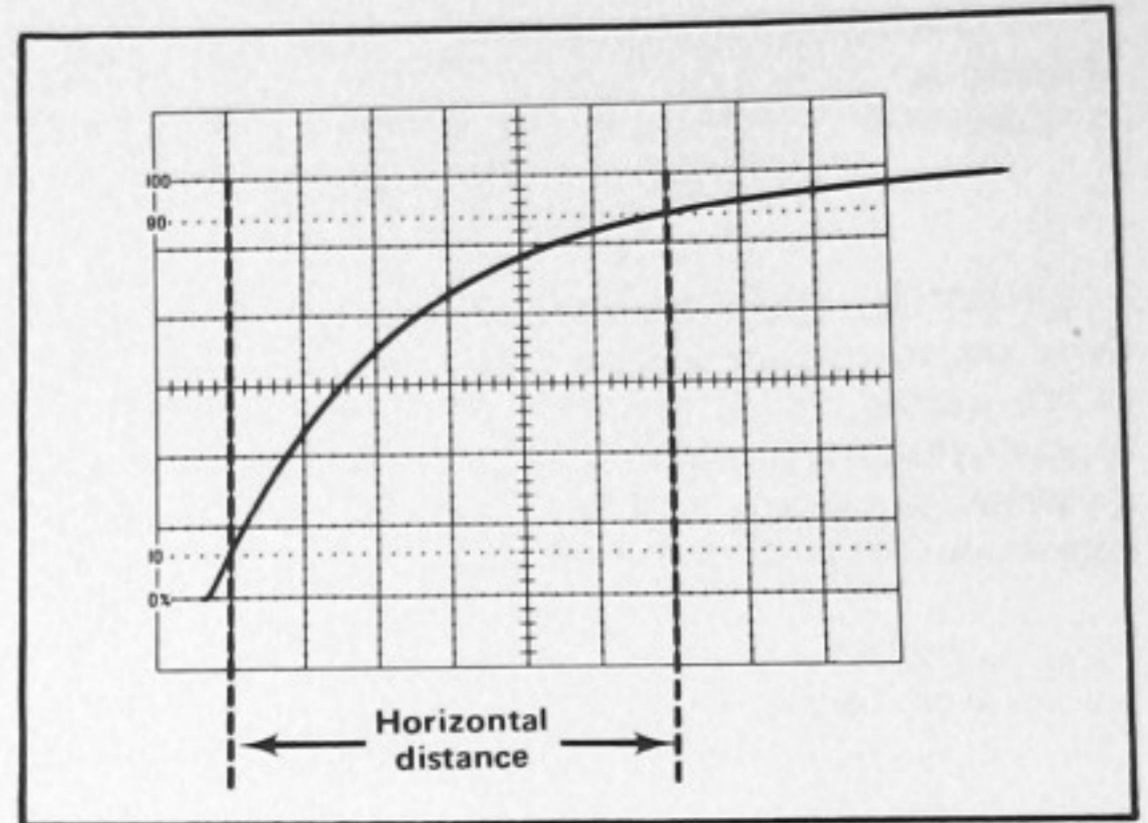

Fig. 2-10. Measuring risetime.

9. Multiply the distance measured in step 8 by the setting of the TIME/DIV switch.

EXAMPLE. Assume that the horizontal distance between the 10% and 90% points is six divisions (see Fig. 2-10) and the TIME/DIV switch is set to 1 μs.

Using the time duration formula to find risetime:

$$\begin{matrix} \text{Time} \\ \text{Duration} \\ \text{(Risetime)} \end{matrix} = \begin{matrix} \text{horizontal} \\ \text{distance} \\ \text{(divisions)} \end{matrix} \times \begin{matrix} \text{TIME/DIV} \\ \text{setting} \end{matrix}$$

Substituting the given values:

$$\text{Risetime} = 6 \times 1 \mu\text{s}$$

The risetime is 6 microseconds.

Time Difference Measurements

The calibrated sweep rate and dual-trace features of the 432 allow measurement of time difference between two separate events. To measure time difference use the following procedure:

1. Set the Input Coupling switches to the same position, depending on the type of coupling desired.
2. Set the Vertical Mode switch to either CHOP or ALT. In general, CHOP is more suitable for low-frequency signals and the ALT position is more suitable for high-frequency signals. More information on determining the mode is given under Dual-Trace Operation in this section.

3. Set the TRIGGER SOURCE switch to CH 1.

4. Connect the reference signal to the CH 1 connector and the comparison signal to the CH 2 connector. The reference signal should precede the comparison signal in time. Use coaxial cables or probes which have equal time delay to connect the signals to the input connectors.

5. If the signals are of opposite polarity, set the INVERT switch out to invert the Channel 2 display (signals may be of opposite polarity due to 180° phase difference; if so, take this into account in the final calculation).

6. Set the VOLTS/DIV switches to produce four or five division displays.

7. Set the TRIGGER LEVEL control for a stable display.

8. If possible, set the TIME/DIV switch for a sweep rate which shows three or more divisions between the two waveforms.

9. Adjust the vertical POSITION controls to center each waveform (or the points on the display between which the measurement is being made) in relation to the center horizontal line.

10. Adjust the horizontal POSITION control so the Channel 1 (reference) waveform crosses the center horizontal line at a vertical graticule line.

11. Measure the horizontal distance between the Channel 1 waveform and the Channel 2 waveform (see Fig. 2-11).

12. Multiply the measured distance by the setting of the TIME/DIV switch.

EXAMPLE. Assume that the TIME/DIV switch is set to 50 μs and the horizontal distance between waveforms is 4.5 divisions (see Fig. 2-11).

Using the formula:

$$\text{Time Delay} = \text{TIME/DIV setting} \times \text{horizontal distance (divisions)}$$

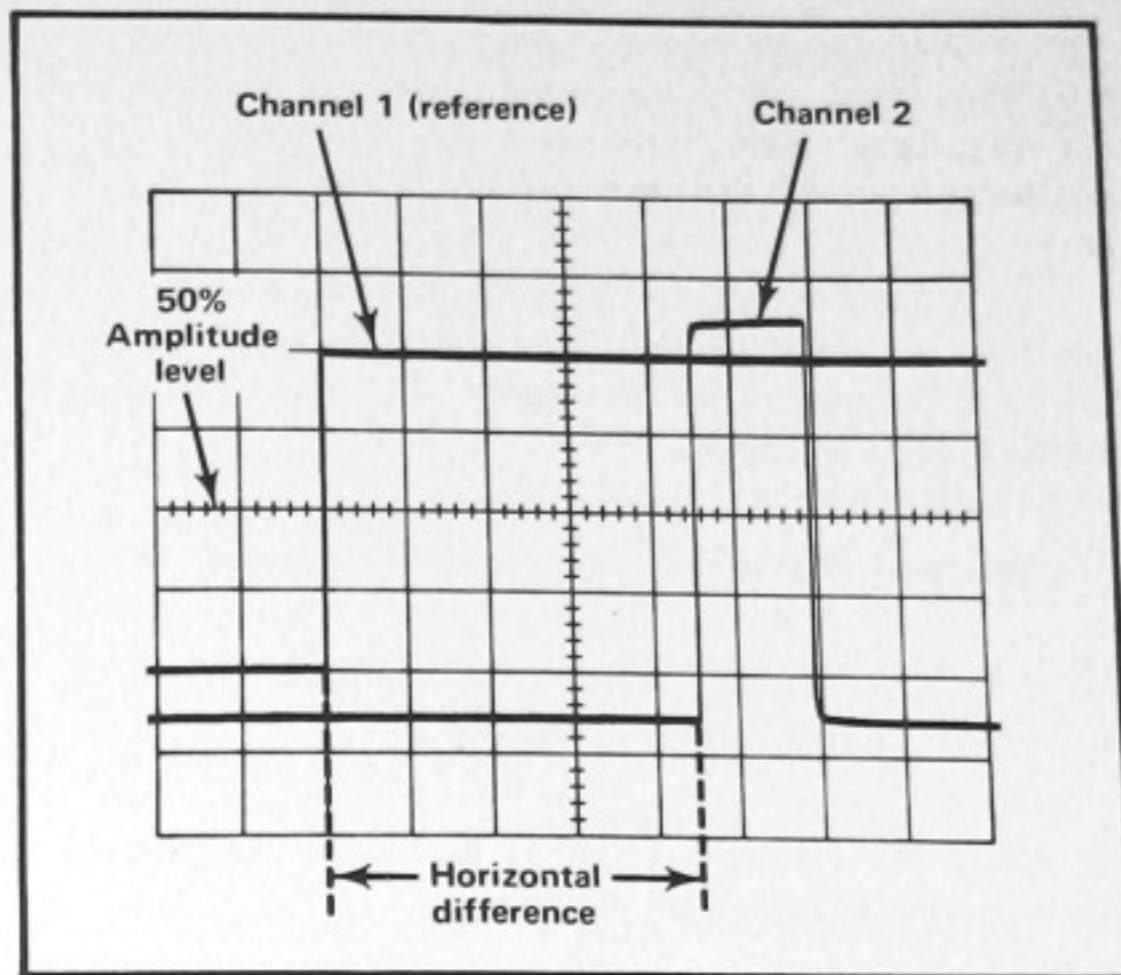

Fig. 2-11. Measuring time difference between two pulses.

Substituting the given values:

$$\text{Time Delay} = 50 \mu\text{s} \times 4.5$$

The time delay is 225 microseconds.

Multi-Trace Phase Difference Measurements

Phase comparison between two signals of the same frequency can be made using the dual-trace feature of the 432. This method of phase difference measurement can be used up to the frequency limit of the vertical system. To make the comparison, use the following procedure.

1. Set the Input Coupling switches to the same position, depending on the type of coupling desired.

2. Set the Vertical Mode switch to either CHOP or ALT. In general, CHOP is more suitable for low-frequency signals and the ALT position is more suitable for high-frequency signals. More information on determining the mode is given under Dual-Trace Operation in this section.

3. Set the TRIGGER COUPLING switch to CH 1.

4. Connect the reference signal to the CH 1 connector and the comparison signal to the CH 2 connector. The reference signal should precede the comparison signal in time. Use coaxial cables or probes which have similar time delay characteristics to connect the signals to the input connectors.

Operating Instructions—432

5. If the signals are of opposite polarity, set the INVERT switch out to invert the Channel 2 display. (Signals may be of opposite polarity due to 180° phase difference; if so, take this into account in the final calculation.)

6. Set the VOLTS/DIV switches and the Variable VOLTS/DIV controls so the displays are equal and about five divisions in amplitude.

7. Set the TRIGGER controls to obtain a stable display.

8. Set the TIME/DIV switch to a sweep rate which displays about one cycle of the waveform.

9. Move the waveforms to the center of the graticule with the vertical POSITION controls.

10. Turn the Variable TIME/DIV control until one cycle of the reference signal (Channel 1) occupies exactly eight divisions between the second and tenth vertical lines of the graticule (see Fig. 2-12). Each division of the graticule represents 45° of the cycle (360° ÷ 8 divisions = 45°/division). The sweep rate can be stated in terms of degrees as 45°/division.

11. Measure the horizontal difference between corresponding points on the waveforms.

12. Multiply the measured distance (in divisions) by 45°/division (sweep rate) to obtain the exact amount of phase difference.

EXAMPLE. Assume a horizontal difference of 0.6 division with a sweep rate of 45°/division as shown in Fig. 2-12.

Using the formula:

$$\text{Phase Difference} = \text{horizontal difference (divisions)} \times \text{sweep rate (degrees/div)}$$

Substituting the given values:

$$\text{Phase Difference} = 0.6 \times 45^\circ$$

The phase difference is 27°.

High Resolution Phase Measurements

More accurate dual-trace phase measurements can be made by increasing the sweep rate (without changing the Variable TIME/DIV control setting). One of the easiest ways to increase the sweep rate is with the MAG switch. The magnified sweep rate (in terms of degrees/division) is determined by dividing the sweep rate obtained previously by the amount of sweep magnification.

EXAMPLE. If the sweep rate were increased 10 times with the magnifier, the magnified sweep rate would be 45°/division ÷ 10 = 4.5°/division. Fig. 2-13 shows the same signals as used in Fig. 2-12 but with the MAG switch set for 10X magnification. With a horizontal difference of six divisions, the phase difference is:

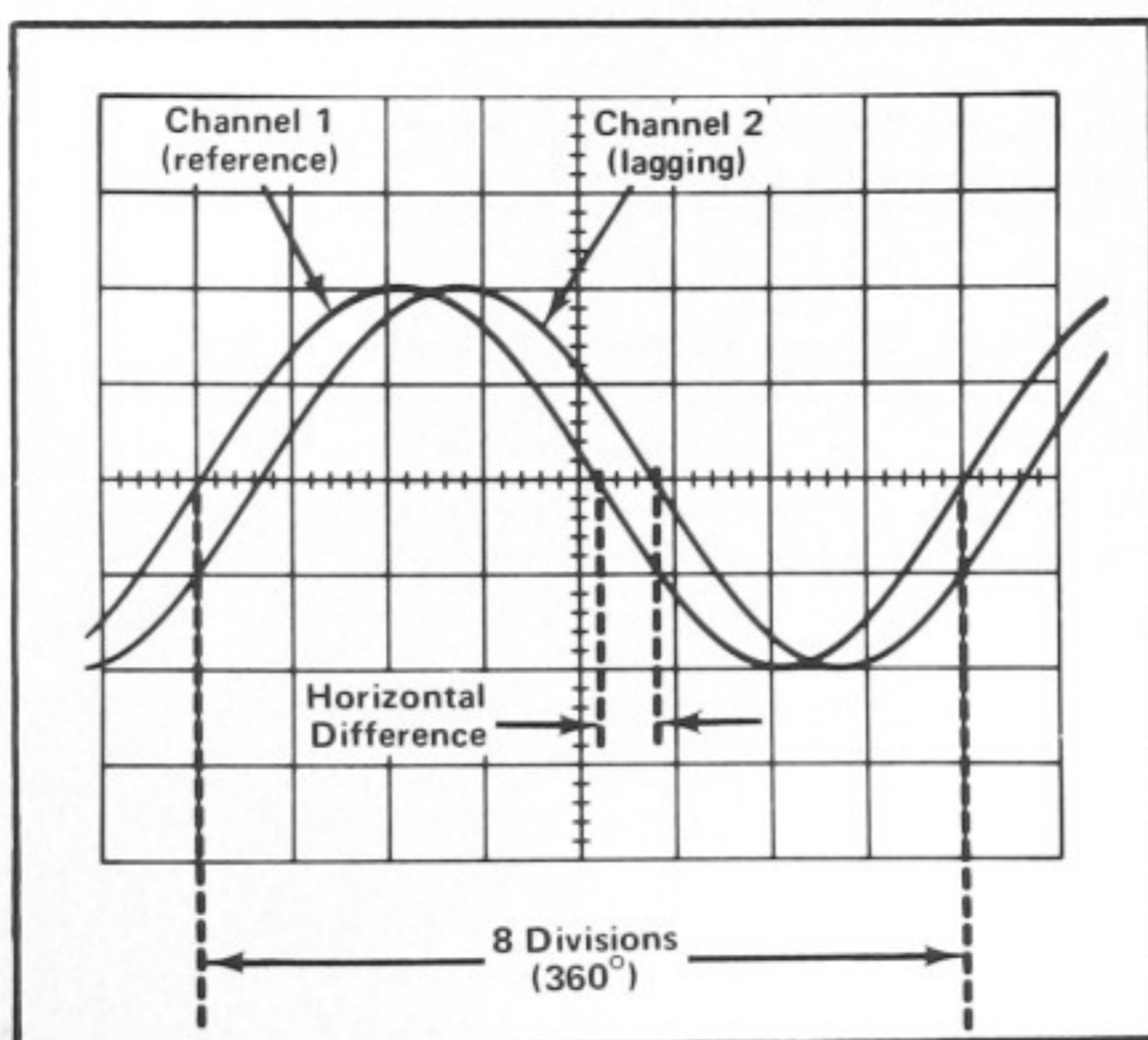

Fig. 2-12. Measuring phase difference.

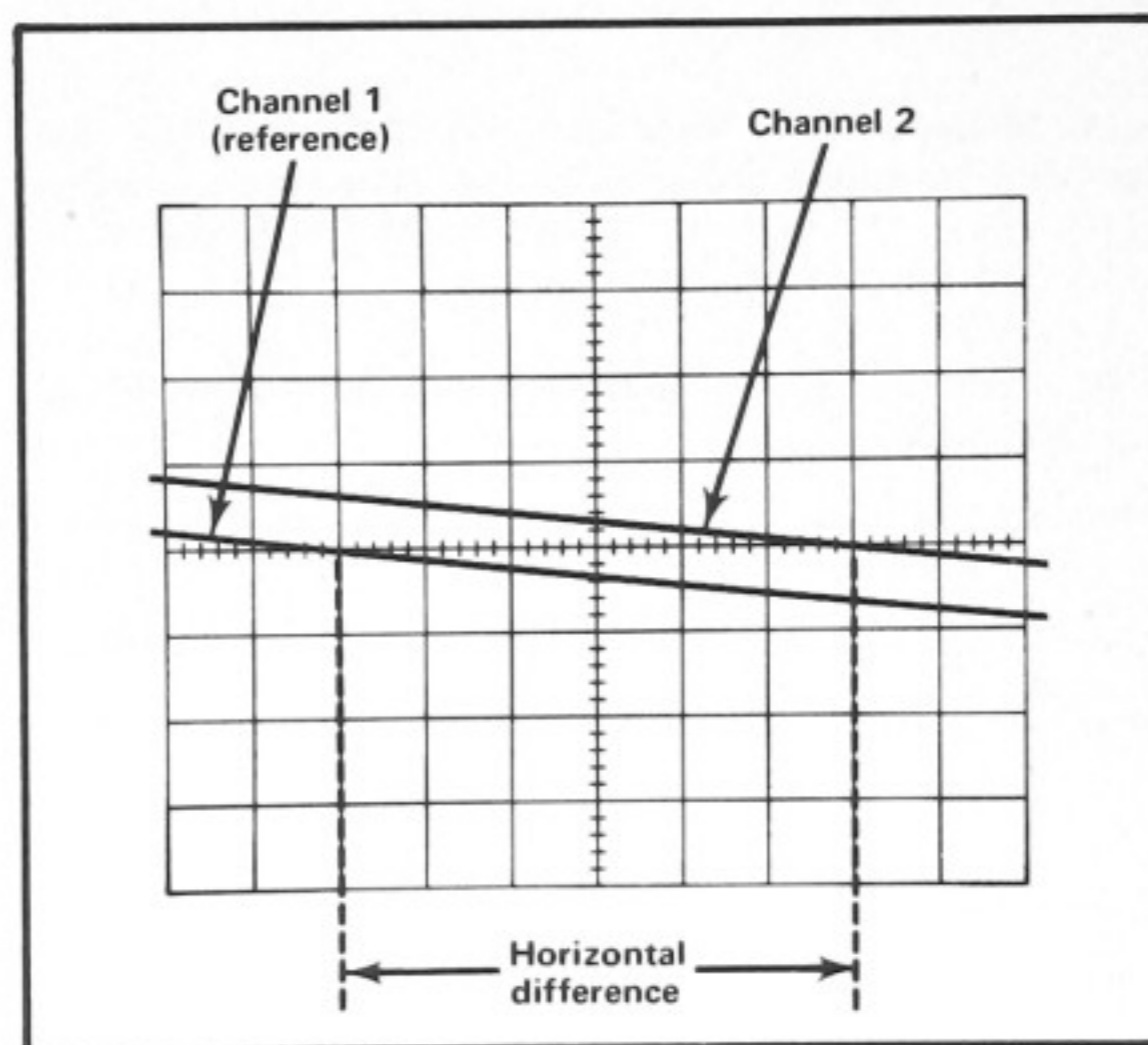

Fig. 2-13. High resolution phase-difference measurement with increased sweep rate.

$$\text{Phase Difference} = \text{Horizontal difference (divisions)} \times \text{magnified sweep rate (degrees/div)}$$

Substituting the given values:

$$\text{Phase Difference} = 6 \times 4.5^\circ$$

The phase difference is 27° .

Common-Mode Rejection

The ADD feature of the 432 can be used to display signals which contain undesirable components. These undesirable components can be eliminated through common-mode rejection. The precautions given under Algebraic Addition should be observed.

4. Set the Vertical Mode switch to ALT. Set the VOLTS/DIV switches so the signals are about equal in amplitude.

5. Set the TRIGGER SOURCE switch to COMP.

6. Set the Vertical Mode switch to ADD. Set the INVERT switch so the common-mode signals are of opposite polarity.

7. Adjust the Channel 2 VOLTS/DIV switch and Variable VOLTS/DIV control for maximum cancellation of the common-mode signal.

8. The signal which remains should be only the desired portion of the Channel 1 signal. The undesired signal is cancelled out.

1. Connect the signal containing both the desired and undesired information to the CH 1 connector.

2. Connect a signal similar to the unwanted portion of the Channel 1 signal to the CH 2 connector. For example, in Fig. 2-14, a line-frequency signal is connected to Channel 2 to cancel out the line-frequency component of the Channel 1 signal.

3. Set both Input Coupling switches to DC (AC if DC component of input signal is too large).

EXAMPLE. An example of this mode of operation is shown in Fig. 2-14. The signal applied to Channel 1 contains unwanted line-frequency components (Fig. 2-14A). A corresponding line-frequency signal is connected to Channel 2 (Fig. 2-14B). Fig. 2-14C shows the desired portion of the signal as displayed when common-mode rejection is used.

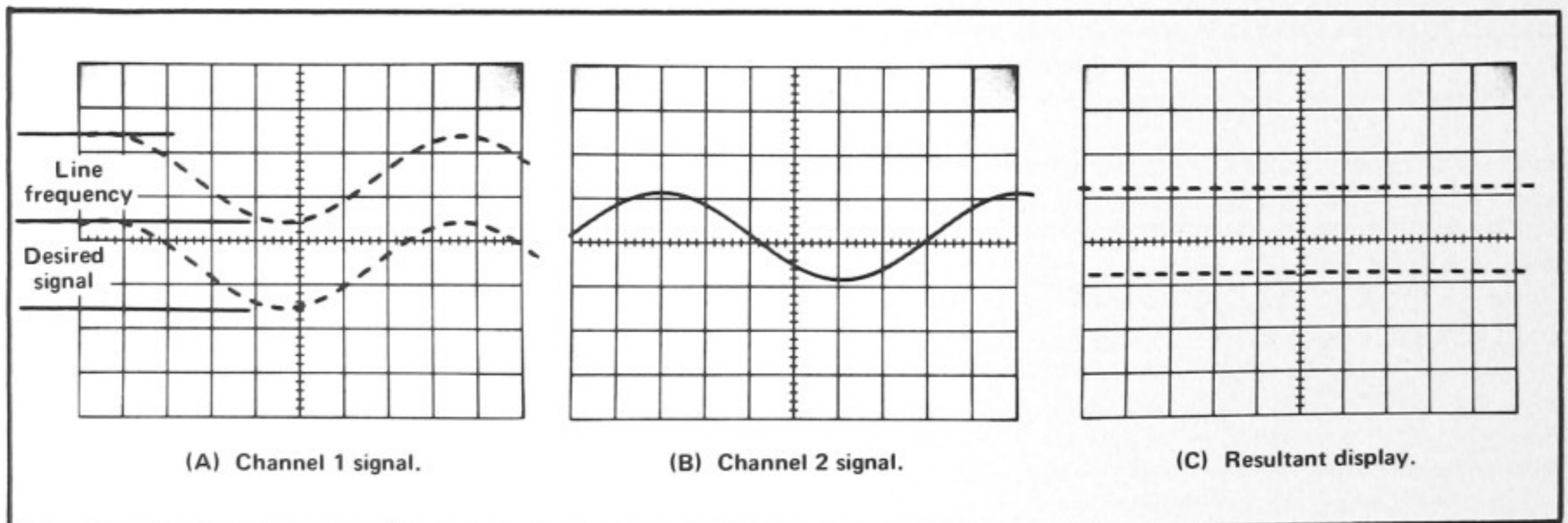

Fig. 2-14. Using the ALG ADD feature for common-mode rejection. (A) Channel 1 signal contains desired information along with line-frequency component. (B) Channel 2 signal contains line-frequency only, (C) resultant CRT display using common-mode rejection.

NOTES

Lined area for notes, consisting of approximately 30 horizontal lines.

SECTION 3

CIRCUIT DESCRIPTION

Change information, if any, affecting this section will be found at the rear of the manual.

Introduction

This section of the manual contains a description of the circuitry used in the 432 Oscilloscope. The description begins with a discussion of the instrument using the basic block diagram shown in Fig. 3-1. Then, each circuit is described in detail, using a detailed block diagram to show the interconnections between the stages in each major circuit and the relationship of the front-panel controls to the individual stages.

A complete block diagram is located in the Diagrams section at the rear of this manual. This block diagram shows the overall relationship between all of the circuits. Complete schematics of each circuit are also given in the Diagrams section. Refer to these diagrams throughout the following circuit description for electrical values and relationship.

BLOCK DIAGRAM

General

The following discussion is provided to aid in understanding the overall concept of the 432 before the individual circuits are discussed in detail. A basic block diagram of the 432 is shown in Fig. 3-1. Only the basic interconnections between the individual blocks are shown on this diagram. Each block represents a major circuit within this instrument. The number on each block refers to the complete circuit diagram which is located at the rear of this manual.

Signals to be displayed on the CRT are applied to the CH 1 and/or CH 2 input connectors. The input signals are then amplified by the Channel 1 Input Amp and Preamp and/or the Channel 2 Input Amp and Preamp circuits. Each vertical circuit includes separate vertical deflection factor, position, input coupling, gain, variable attenuation, and balance controls. A sample of the Channel 1 signal is supplied to the Trigger Pickoff circuit. The Channel 2 Preamp circuit contains an invert feature to invert the Channel 2 signal as displayed on the CRT. The output of both Vertical Preamp circuits is connected to the Channel Switch circuit. This circuit selects the channel(s) to be displayed. An output signal from this circuit is connected to the Z Axis Amplifier circuit to blank out the between-channel switching transients when in the chopped mode of

operation. A sample of the signal present in the Channel Switch circuit is supplied to the Trigger Pickoff circuit.

The output of the Channel Switch circuit is connected to the Vertical Output Amplifier through the Delay Line. The Vertical Output Amplifier circuit provides the final amplification for the signal before it is connected to the vertical deflection plates of the CRT. This circuit includes the BEAM FINDER switch which compresses the vertical and horizontal deflection within the viewing area to aid in locating an off-screen display.

The Trigger Pickoff and Generator circuit selects a trigger signal (determined by the TRIGGER SOURCE switch) and produces an output pulse which initiates the sweep signal produced by the Sweep Generator circuit. The internal trigger signal is selected from the Channel 1 circuit or the Channel Switch circuit. A sample of the line voltage applied to the instrument or an external signal applied to the EXT TRIG input connector can also be used to generate a sweep-starting pulse. The trigger circuit contains level, slope, coupling, and source controls.

The Sweep Generator circuit produces a linear sawtooth output signal when initiated by the Trigger Generator circuit. The slope of the sawtooth produced by the Sweep Generator circuit is controlled by the TIME/DIV switch. The operating mode of the Sweep Generator circuit is controlled by the sweep MODE switch. In the AUTO mode of operation, the absence of an adequate trigger signal causes the sweep to free run. In the NORM mode, a horizontal sweep is presented only when correctly triggered by an adequate trigger signal. The SINGLE SWEEP mode of operation allows one (and only one) sweep to be initiated after the circuit is reset with the RESET button. The Sweep Generator also produces an unblanking gate signal to unblank the CRT so the display can be presented. This gate signal is coincident with the sawtooth produced by the Sweep Generator circuit. Additionally, the Sweep Generator circuit produces an alternate trace sync pulse which is connected to the Channel Switch circuit. This pulse switches the display between channels at the end of each sweep when in the ALT mode of operation.

The output of the Sweep Generator circuit is amplified by the Horizontal Amplifier circuit to produce horizontal

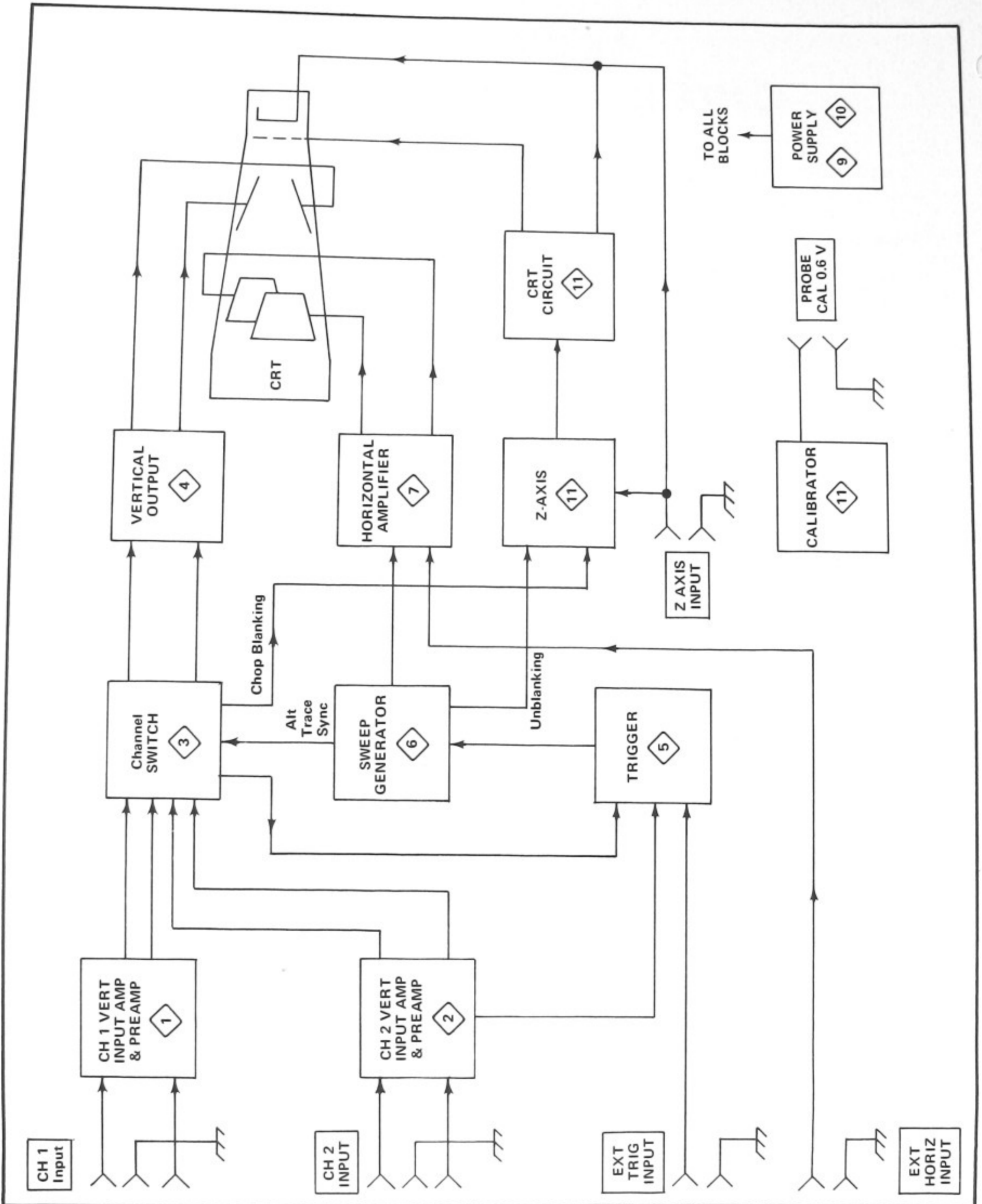

Fig. 3-1. Basic block diagram of the 432.

deflection for the CRT in all positions of the TIME/DIV switch except EXT HORIZ. This circuit contains a six-position magnifier switch to increase the sweep rate up to a maximum of 50 times. Other horizontal deflection signals can be connected to the Horizontal Amplifier by using the EXT HORIZ mode of operation. When the TIME/DIV switch is set to EXT HORIZ, the X signal is connected to the Horizontal Amplifier circuit via the EXT HORIZ input connector on the instrument rear panel.

The CRT circuit determines the CRT intensity by summing the signal inputs from the INTENSITY control, Channel Switch circuit (chopped blanking), Sweep Generator (unblanking), and the Z AXIS input connector. The CRT circuit also contains the controls necessary for operation of the cathode-ray tube.

The Power Supply circuit provides all the voltages necessary for operation of this instrument. The Calibrator circuit provides a square-wave output with accurate amplitude and frequency which can be used to check the calibration of the instrument and the compensation of probes.

CIRCUIT OPERATION

General

This section provides a detailed description of the electrical operation and relationship of the circuits in the 432. The theory of operation for circuits unique to this instrument is described in detail in this discussion. Circuits which are commonly used in the electronics industry are not described in detail. If more information is desired on these commonly used circuits, refer to the following textbooks:

Tektronix Circuit Concepts Books (order from your local Tektronix Field Office or representative).

Cathode-Ray Tubes, Tektronix Part No. 062-0852-01.

Horizontal Amplifier Circuits, Tektronix Part No. 062-1144-00.

Oscilloscope Trigger Circuits, Tektronix Part No. 062-1056-00.

Power Supply Circuits, Tektronix Part No. 062-0888-01.

Sweep Generator Circuits, Tektronix Part No. 062-1098-01.

Vertical Amplifier Circuits, Tektronix Part No. 062-1145-00.

Phillip Cutler, "Semiconductor Circuit Analysis", McGraw-Hill, New York, 1964.

Lloyd P. Hunter (Ed.), "Handbook of Semiconductor Electronics", second edition, McGraw-Hill, New York, 1962.

Jacob Millman and Herbert Taub, "Pulse, Digital, and Switching Waveforms", McGraw-Hill, New York, 1965.

The following circuit analysis is written around the detailed block diagrams which are given for each major circuit. These detailed block diagrams give the names of the individual stages within the major circuits and show how they are connected together to form the major circuit. The block diagrams also show the inputs and outputs for each circuit and the relationship of the front-panel controls to the individual stages. The circuit diagrams from which the detailed block diagrams are derived are shown in the Diagrams section.

CHANNEL 1 INPUT AMP AND PREAMP

General

Input signals for vertical deflection on the CRT can be connected to the CH 1 connector. The Channel 1 Input Amp and Preamp circuits provide control of input coupling, vertical deflection factor, balance, vertical position, and vertical gain. A sample of the Channel 1 input signal is also provided to the Trigger Pickoff and Generator circuit to provide internal triggering from the Channel 1 signal only. Fig. 3-2 shows a detailed block diagram of the Channel 1 Input Amp and Preamp circuits. A schematic of these circuits is shown on diagram 1 at the rear of the manual.

Input Coupling

Input signals applied to the CH 1 connector can be AC-coupled, DC-coupled, or internally disconnected. When Input Coupling switch S8A is in the DC position, the input signal is coupled directly to the Input Attenuator circuit. In the AC position, the input signal passes through capacitor C8. This capacitor prevents the DC component of the signal from passing to the amplifier. When the GND pushbutton is pressed in, switch S8B opens the signal path and the input to the amplifier is connected to ground. This provides a ground reference without the need to disconnect the applied signal from the CH 1 input connector. Resistor R8 allows C8 to be precharged so the trace remains on screen when switched to AC coupling with a high DC level applied. Variable capacitor C9 adjusts the basic input time constant for a nominal value of one megohm X 24 picofarads.

Input Attenuator

The effective overall Channel 1 deflection factor of the 432 is determined by the CH 1 VOLTS/DIV switch. In all

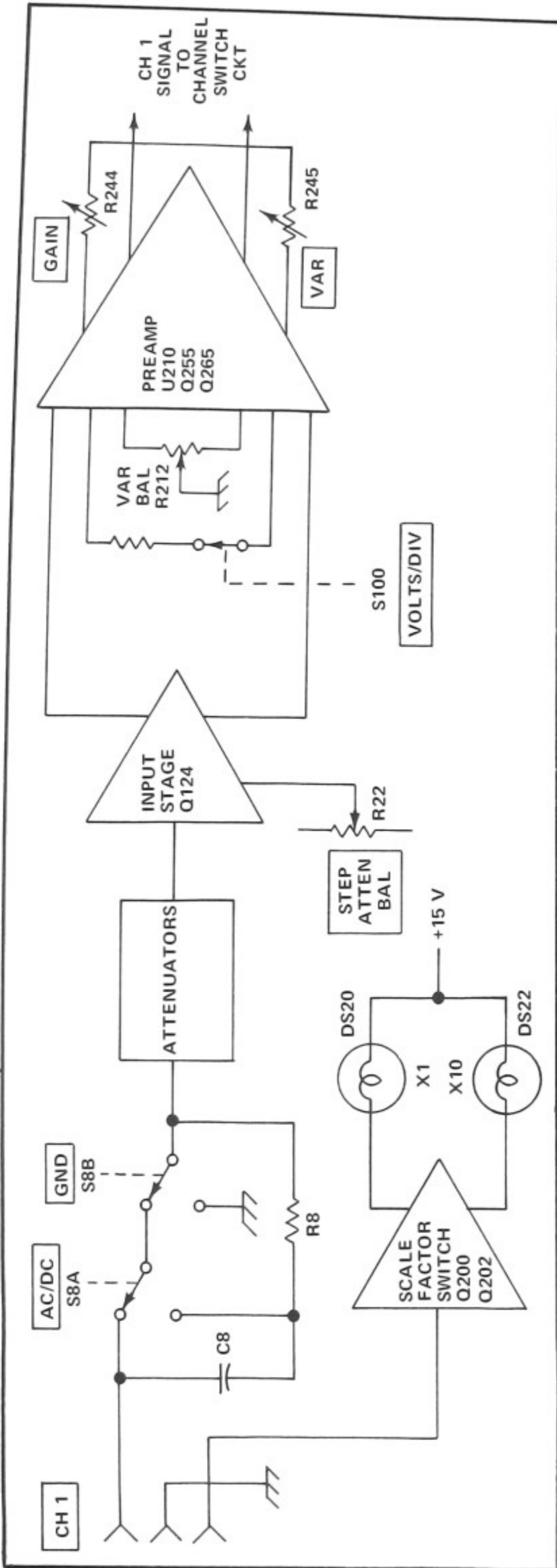

Fig. 3-2. Channel 1 Input Amp and Preamp detailed block diagram.

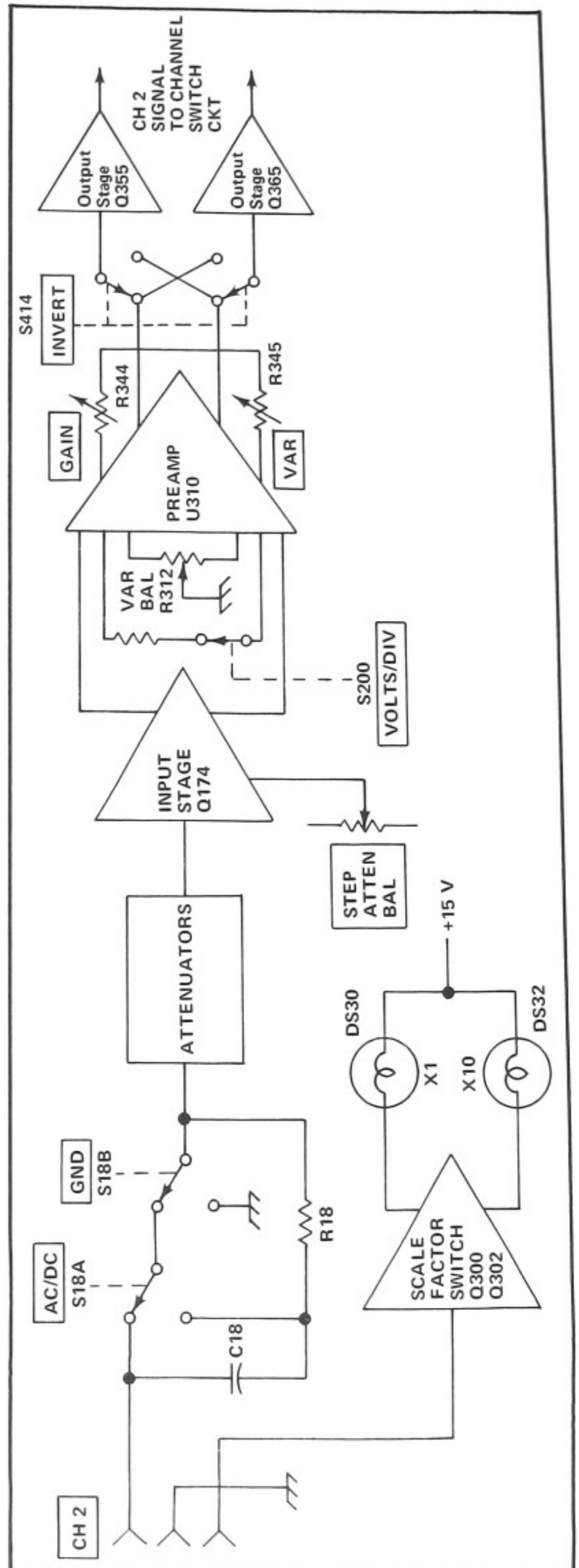

Fig. 3-3. Channel 2 Input Amp and Preamp detailed block diagram.

positions of the CH 1 VOLTS/DIV switch above 5 mV, the basic deflection factor of the Vertical Deflection System is 10 millivolts per division of CRT deflection. To increase this basic deflection factor to the values indicated by the VOLTS/DIV switch, precision attenuators are switched into the circuit. In the 1, 2, 5, and 10 mV positions, input attenuation is not used. Instead, the gain of the Preamp Circuit is changed to decrease the deflection factor (see Preamp Circuit discussion).

For the CH 1 VOLTS/DIV switch positions above 10 mV, the attenuators are switched into the circuit singly or in pairs to produce the vertical deflection factor indicated by the VOLTS/DIV switch. These attenuators are frequency-compensated voltage dividers. In addition to providing constant attenuation at all frequencies within the bandwidth of the instrument, the Input Attenuators are designed to maintain the same input RC characteristics (one megohm X 24 picofarads) for each setting of the CH 1 VOLTS/DIV switch. Each attenuator contains an adjustable series capacitor to provide correct attenuation at high-frequencies and an adjustable shunt capacitor to provide correct input capacitance.

NOTE

Each attenuator is a hybrid encapsulated assembly; therefore, replacement of individual components is not possible. Should defects occur, the attenuator must be replaced as a unit.

Scale-Factor Switching Circuit

The vertical deflection factor of Channel 1 is indicated by back-lighting the appropriate figures imprinted on the flange of the CH 1 VOLTS/DIV knob. When a X1 probe is connected to the CH 1 input connector, the base of Q200 is connected to +15 volts through R200. Q200 is biased into saturation and conducts current through indicator DS20. DS20 indicates the correct deflection factors for X1 probes. When Q200 conducts, the voltage level at its collector is very close to zero volts; therefore, there is insufficient bias at the base of Q202 to cause it to conduct, and X10 indicator DS22 remains dark.

When a X10 probe with a scale factor switching connector is attached to the CH 1 input connector, the base of Q200 is grounded. Q200 does not conduct, and its collector rises to approximately +15 volts. X1 indicator DS20 is dark and Q202 is forward biased into conduction. Q202 conducts current through X10 indicator DS22, which now indicates the correct vertical deflection factor, including the X10 attenuation ratio of the attached probe.

Input Stage

The Channel 1 signal from the Input Attenuator is connected to the Input Stage through C121, R121, and

R122. R120 provides the input resistance for this stage. R121 limits the current drive to the gate of Q124A. Dual-diode CR122 protects the circuit by clamping the gate of Q124A at about -15.5 or +15.5 volts if a high-amplitude signal is applied to the CH 1 connector. FET Q124B is a relatively constant current source for Q124A, and also provides temperature compensation of Q124A. R125 isolates the input of the Preamp Stage from the source of Q124A.

Preamp Stage

The Preamp Stage U210 is a multiple-stage integrated circuit amplifier. Adjusting the gain of this stage sets the overall gain for Channel 1. Basic gain of the amplifier is set by adjusting R244. VAR control R245 permits continuously variable uncalibrated deflection factors between the calibrated settings of the VOLTS/DIV switch. R212 adjusts for no base line shift of the CRT display when rotating the VAR control.

In the 1, 2, 5, and 10 mV positions of the VOLTS/DIV switch no attenuation is used in the Input Attenuator stage. The correct vertical deflection factors are obtained by changing the gain of the Channel 1 Preamp Stage. This is accomplished by changing the value of the gain-setting resistance connected between pins 7 and 8 of U210. The STEP ATTEN BAL screwdriver adjustment R22 located on the instrument front panel adjusts for no baseline shift of a CRT display when switching between the 1, 2, 5, and 10 mV positions of the CH 1 VOLTS/DIV switch.

Variable capacitors C217, C220, C223, C225, and C226 are compensation adjustments to provide optimum high-frequency response through the channel amplifier. A sample of the signal being amplified in Channel 1 is taken from pin 19 of U210 and connected to the Trigger Pickoff and Generator circuit to allow Channel 1 only triggering operation. Q255 and Q265 in the Output Amplifier stage are connected as common-base amplifiers to provide low input impedance load for the Preamp Stage. They also provide isolation between the Preamp Stage and the Channel Switch circuitry.

CHANNEL 2 INPUT AMP AND PREAMP

General

The Channel 2 Input Amp and Preamp circuits are basically the same as the Channel 1 Input Amp and Preamp circuits. Only the differences between the two circuits are described here. Portions of this circuit not described in the following description operate in the same manner as for the Channel 1 Input Amp and Preamp. Fig. 3-3 shows a detailed block diagram of the Channel 2 Input Amp and Preamp. A schematic of these circuits is shown on diagram 2 at the rear of this manual.

Preamp Stage

Basically the Channel 2 Preamp Stage operates as described for Channel 1. However, the Channel 2 Preamp stage does not make available a sample of the Channel 2 signal for triggering use. Also, INVERT switch S414 has been added in the Channel 2 circuit. This switch allows the displayed signal from Channel 2 to be inverted.

CHANNEL SWITCH

General

The Channel Switch circuit determines whether the CH 1 and/or CH 2 Vertical Preamp output signal is connected to the Vertical Output Amplifier circuit. In the ALT and CHOP modes of operation, both channels are alternately displayed on a shared-time basis. Fig. 3-4 shows a detailed block diagram of the Channel Switch circuit. A schematic of this circuit is shown on diagram 3 at the rear of this manual.

Diode Gate

The Diode Gates, consisting of four diodes each, can be thought of as switches which allow either of the Vertical Preamp output signals to be coupled to the Delay-Line Driver stage. CR404, CR405, CR406, and CR408 control the Channel 1 signal output, and CR410, CR411, CR412,

and CR414 control the Channel 2 signal output. These diodes are in turn controlled by the Switching Multivibrator for dual-trace displays, or by the Vertical Mode switch for single-trace displays.

CH 1. In the CH 1 mode of operation, -15 volts is applied to the junction of CR411-CR412 in the Channel 2 Diode Gate through Vertical Mode switch S45A, R427, and CR433 (see simplified diagram in Fig. 3-5). This forward biases CR411-CR412 and reverse biases CR410-CR414, since the input to the Delay-Line Driver Stage is at about +6 volts. CR410-CR414 block the Channel 2 signal so it cannot pass to the Delay-Line Driver stage. At the same time in the Channel 1 Diode Gate, CR405-CR406 are connected to +15 volts through R420. CR405-CR406 are held reverse biased, while CR404-CR408 are forward biased. Therefore, the Channel 1 signal can pass to the Delay-Line Driver stage.

CH 2. In the CH 2 mode of operation, the above conditions are reversed. CR405-CR406 are connected to -15 volts through S45E, R429, and CR431, and CR411-CR412 are connected to +15 volts through R425 (see simplified diagram in Fig. 3-6). The Channel 1 Diode Gate blocks the signal, and the Channel 2 Diode Gate allows it to pass.

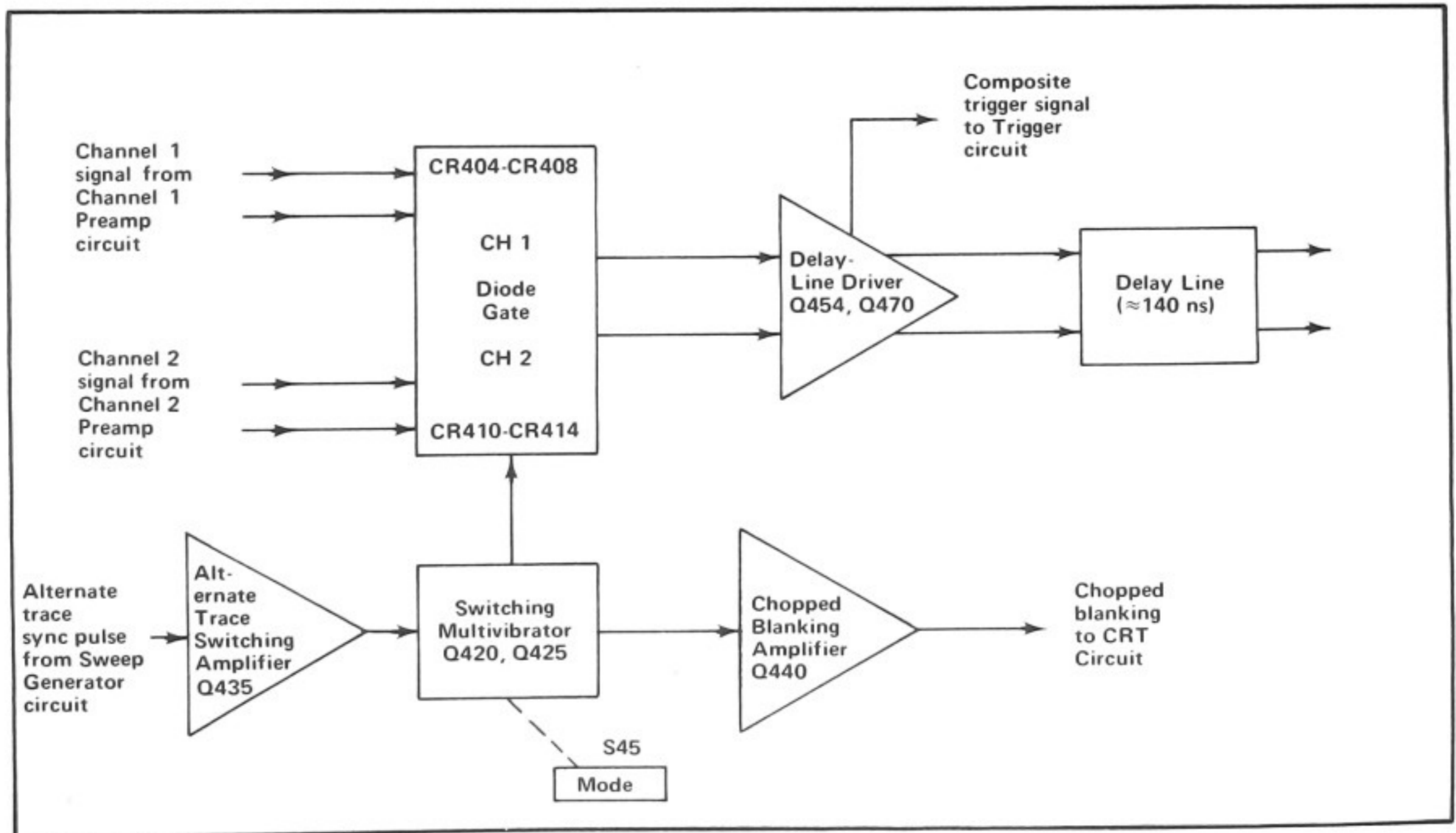

Fig. 3-4. Channel Switch detailed block diagram.

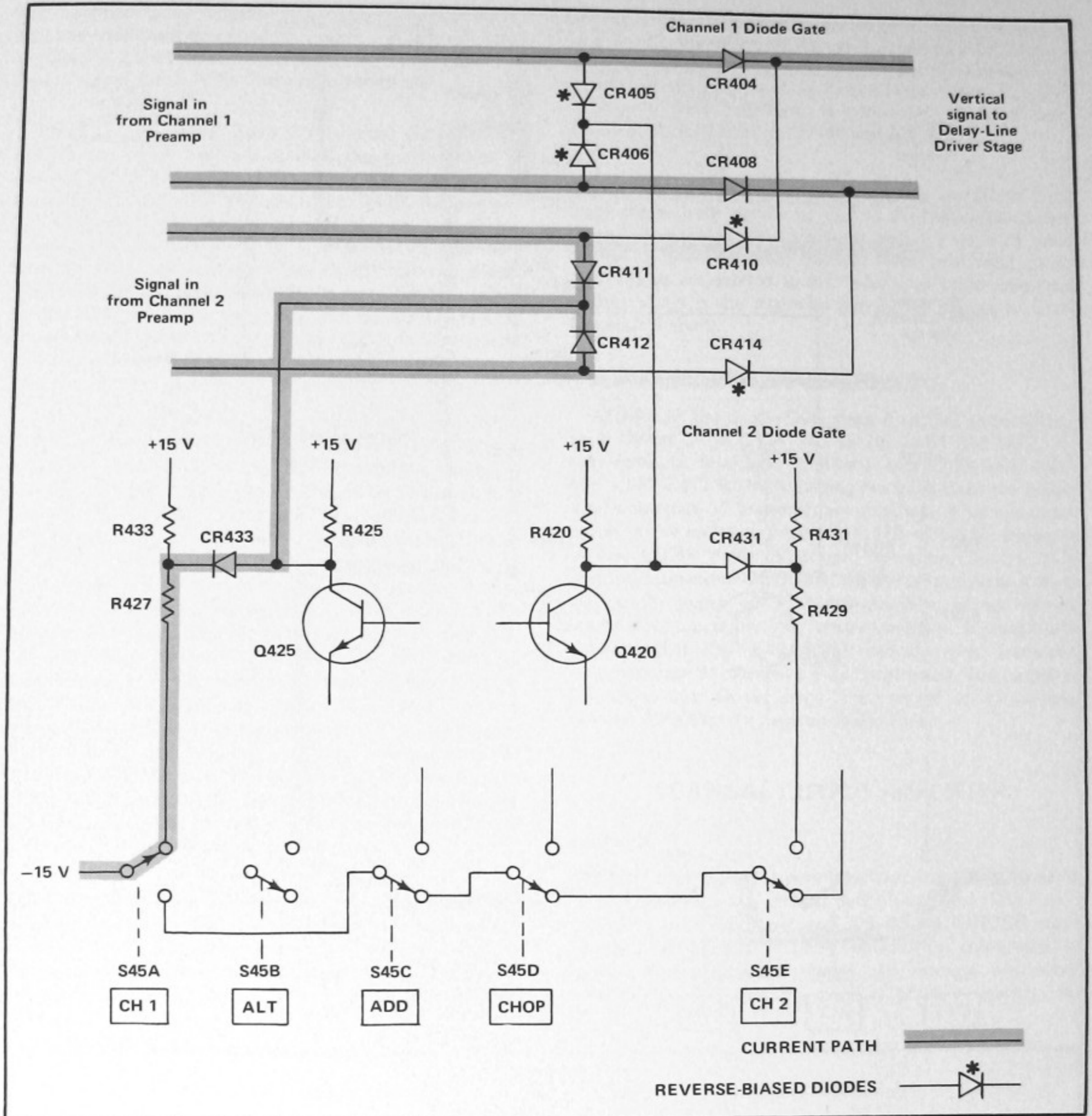

Fig. 3-5. Effect of Diode Gates on signal path (simplified path). Conditions shown for CH 1 mode of operation.

Switching Multivibrator

ALT. In this mode of operation, the Switching Multivibrator operates as a bistable multivibrator. -15 volts is connected to the emitter of Q435 (Alternate Trace Switching Amplifier stage) through R437. Q435 is forward biased and supplies current to the "on" transistor in the Switching Multivibrator stage through R435 and CR428 or CR426.

For example, if Q420 is conducting, current is supplied to Q420 through CR426. The current flow through collector resistor R420 drops the CR405-CR406 cathode level negative with respect to the cathodes of CR404 & CR408, so the Channel 1 Diode Gate is blocked, as for Channel 2 only operation. The signal passes through the Channel 2 Diode Gate to the Delay-Line Driver.

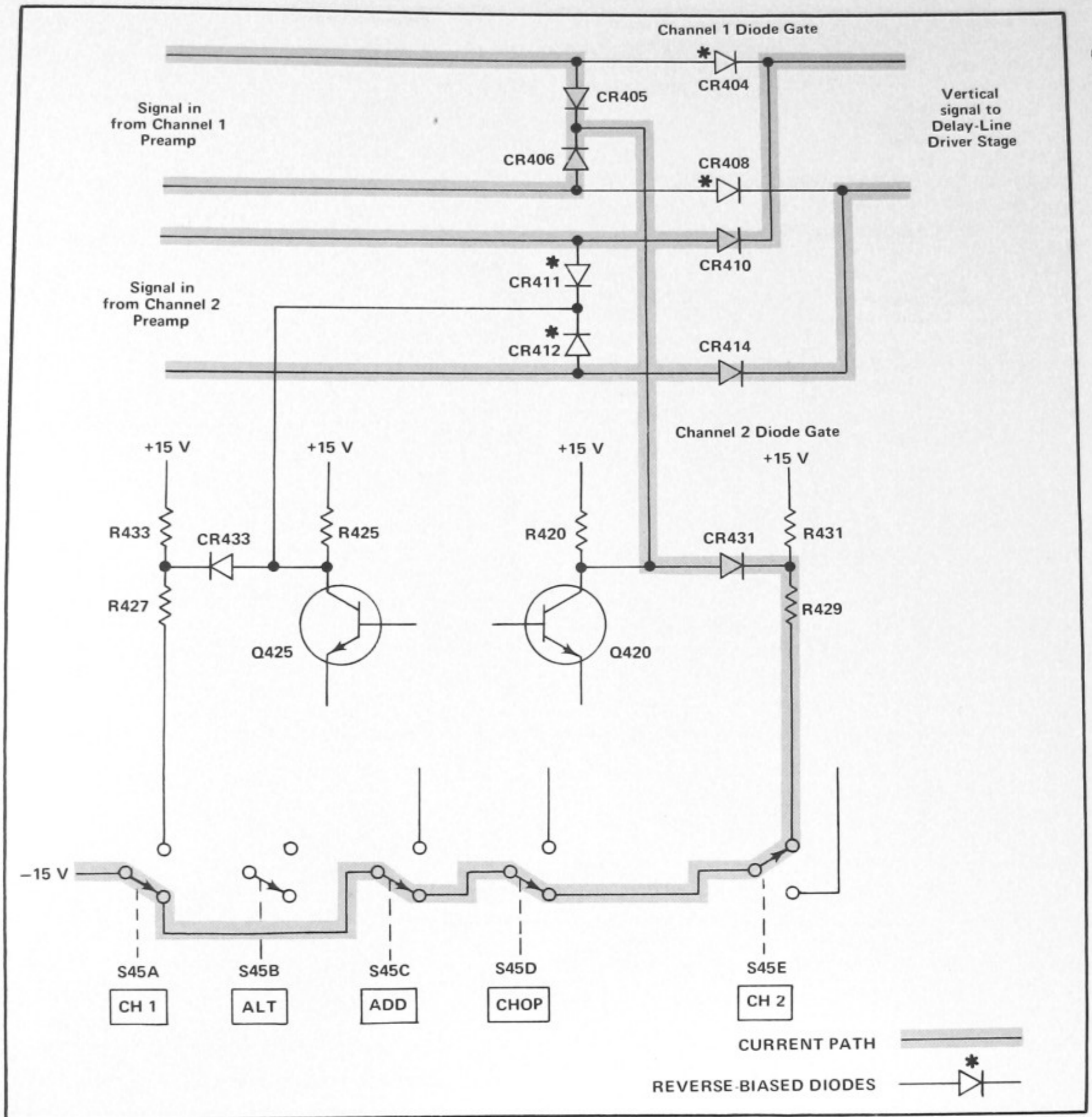

Fig. 3-6. Effect of Diode Gates on signal path (simplified path). Conditions shown for CH 2 mode of operation.

The alternate-trace sync pulse is applied to Q435 through C430 at the end of each sweep. This differentiated negative-going sync pulse momentarily interrupts the current through Q435, and both Q420 and Q425 are turned off. When Q435 turns on again after the alternate-trace sync pulse, the charge on C425 determines whether Q420 or Q425 conducts. For example, when Q420 is conducting, C425 is charged more positively on the CR426 side to the

emitter level of Q420, and more negatively (toward the collector level of Q435 through R428, CR432 and R432) on the CR428 side. This charge is stored while Q435 is off, and holds the emitter of Q425 more negative than the emitter of Q420. When both Q420 and Q425 are off the voltage at their bases becomes approximately equal. When Q435 comes back on, the transistor with the most negative emitter will start conducting first, with the resulting nega-

tive movement at its collector holding the other transistor off. The conditions described previously are reversed; now the Channel 2 Diode Gate is reverse biased, and the Channel 1 signal passes through the Channel 1 Diode Gate.

CHOP. In the CHOP mode of operation, the Switching Multivibrator stage free runs as an astable multivibrator at about a 100 kHz rate. The emitters of Q420 and Q425 are connected to -15 volts through R428, R426, the primary of T435, and R438. At the time of turn-on, one of the transistors begins to conduct; for example, Q420. The negative level at the collector of Q420 forward biases CR405-CR406 and back biases CR404 and CR408, preventing the Channel 1 signal from reaching the Delay-Line Driver stage. Meanwhile, the Channel 2 Diode Gate passes the Channel 2 signal to the Delay-Line Driver stage.

The frequency-determining components in the CHOP mode are C425-R419-R426-R428. Switching action occurs as follows: when Q420 is on, C425 attempts to charge to -15 volts through R428. The emitter of Q425 slowly goes toward -15 volts as C425 charges. The base of Q425 is held at a negative point determined by the voltage divider R423-R421 between -15 volts and the collector voltage of Q420. When the emitter voltage of Q425 reaches a level slightly more negative than its base, Q425 conducts. Its collector level goes negative and pulls the base of Q420 negative through divider R422-R424 to cut Q420 off. This switches the Diode Gate stage to connect the opposite half to the Delay-Line Driver stage. Again C425 begins to charge toward -15 volts, but this time through R426. The emitter of Q420 slowly goes negative as C425 charges, until Q420 turns on. Q425 is shut off and the cycle begins again. Diodes CR426 and CR428 are prevented from conducting by CR432 and R432, so they are effectively removed from the circuit in the CHOP mode.

The Chopped Blanking Amplifier stage, Q440, provides an output pulse to the Z Axis Amplifier circuit which blanks out the transitions between the Channel 1 and the Channel 2 traces. When the Switching Multivibrator stage changes states, the voltage across T435 momentarily

increases. A negative pulse is applied to the base of Q440 to turn it off. The width of the pulse at the base of Q440 is determined by R436 and C436. Q440 is quickly driven into cutoff and the positive-going output pulse, which is coincident with trace switching, is connected to the Z Axis Amplifier circuit through CR440 and R445.

ADD. In the ADD mode of operation, the Diode Gate stage allows both signals to pass to the Delay-Line Driver stage. The Diode Gates are both held on by -15 volts applied to their cathodes through R450 and R452. Since both signals are applied to the Delay-Line Driver stage, the output signal is the algebraic sum of the signals on both Channels 1 and 2.

Delay-Line Driver

Output of the Diode Gate stage is applied to the Delay-Line Driver stage Q454 and Q470. Q454 and Q470 are connected as feedback amplifiers with C456-R456-R457 and C472-R472-R474 providing feedback from the collector to the base of the respective transistor. A sample of the signal in the collector circuit of Q470 is used for triggering in the COMP mode of trigger operation. Switch S479 connects capacitor C479 between the output signal lines to reduce the upper -3 dB bandwidth limit of the Vertical Amplifier system to approximately 5 megahertz. C460-R460 and C461-R461 provide high frequency compensation of the Delay Line termination. The output of the Delay-Line Driver stage is connected to the Vertical Output Amplifier through the Delay Line.

VERTICAL OUTPUT AMPLIFIER

General

The Vertical Output Amplifier circuit provides the final amplification for the vertical deflection signal. This circuit includes the Delay Line and the BEAM FINDER pushbutton. The BEAM FINDER pushbutton compresses an overscanned display to within the viewing area when pressed. Fig. 3-7 shows a detailed block diagram of the

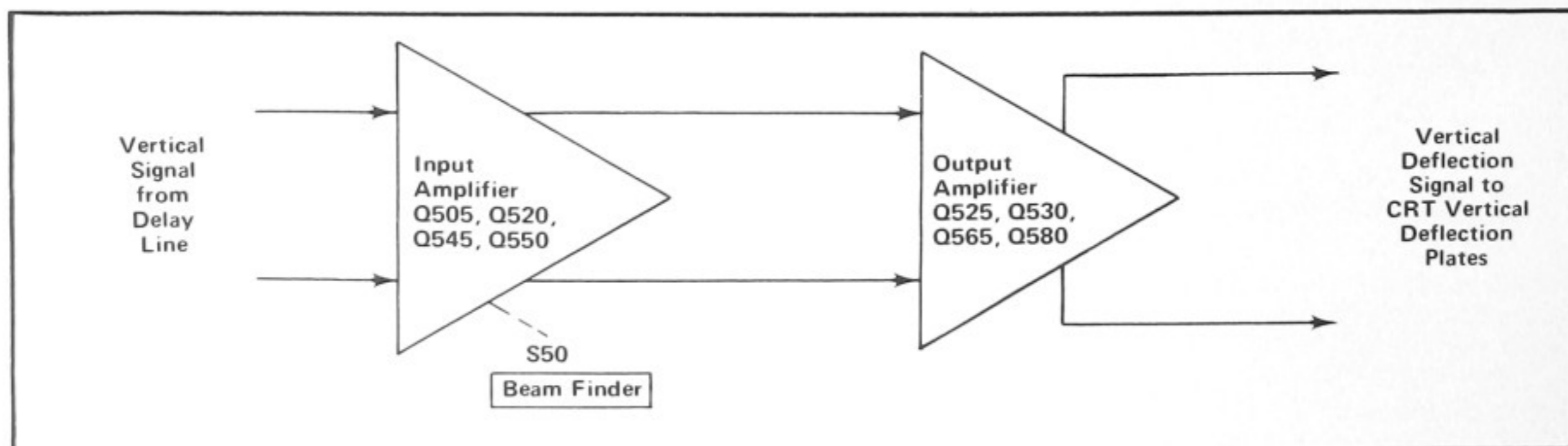

Fig. 3-7. Vertical Output Amplifier detailed block diagram.

Circuit Description—432

Vertical Output Amplifier circuit. A schematic of this circuit is shown on diagram 4 at the rear of this manual.

Delay Line

Delay Line DL500 provides approximately 140 nanoseconds delay for the vertical signal to allow the Sweep Generator circuits time to initiate a sweep before the vertical signal reaches the vertical deflection plates of the CRT. This allows the instrument to display the leading edge of the signal originating the trigger pulse when using internal triggering.

Input Amplifier

Q505 and Q545 are connected as common-base amplifiers to provide a low input impedance to properly terminate the Delay Line. It also provides isolation between the Delay Line and the following stages. Q520 and Q550 limit the maximum dynamic swing of the amplifier by turning on and conducting when excessive amounts of signal are present at the amplifier input. When closed, the BEAM FINDER switch S50 forward biases CR521 and CR551, thereby setting a more positive level at the bases of Q520 and Q550. This more positive level makes Q520 and Q550 conduct on smaller-than-normal overdrive signals, causing the overall dynamic swing of the Vertical Output Amplifier to be limited within the CRT graticule area. Q515 and Q555 are emitter followers to provide low output impedance.

Output Amplifier

Q525 and Q565 comprise an emitter-coupled push-pull amplifier that drives the output power amplifiers Q530 and Q580. R568, R571, R572 and R574 set the gain of the stage by controlling the signal degeneration between the emitters of Q525 and Q565. R572 is a thermistor which reduces in resistance with increases in ambient temperature. This increases the gain of the stage, to counteract the reduction in overall amplifier gain that occurs when the ambient temperature increases. Variable capacitor C572 and the series RC network C570 and R570 provide high-frequency compensation to optimize amplifier frequency response. L533 and L584 are high-frequency peaking adjustments to provide additional amplifier compensation.

TRIGGER PICKOFF AND GENERATOR

General

The Trigger Pickoff circuit selects and amplifies the internal trigger signal to the level necessary to drive the Trigger Generator circuit. Input signal for the Trigger Pickoff circuit is either a sample of the signal applied to Channel 1, or a sample of the composite vertical signal from the Channel Switch circuit.

The Trigger Generator circuit produces trigger pulses to start the Sweep Generator circuit. These trigger pulses are derived either from the internal trigger signal from the vertical deflection system, an external signal connected to the EXT TRIG input connector, or a sample of the line voltage applied to the instrument. Controls are provided in this circuit to select trigger level, slope, coupling, and source. Fig. 3-8 shows a detailed block diagram of the Trigger Pickoff & Generator circuit. A schematic of this circuit is shown on diagram 5 at the back of this manual.

Trigger Pickoff

Diode Gate. The Diode Gates, consisting of two diodes each, can be thought of as switches which allow either of the two internal trigger signals to be coupled to the Trigger Pickoff Amplifier. CR280 and CR285 control the Channel 1 signal, and CR270 and CR275 control the composite signal. These diodes are in turn controlled by the TRIGGER SOURCE switches.

For CH 1 trigger operation, +15 volts is applied to the anode of CR270 through COMP Source switch S72B. CR270 is forward biased and pulls the collector circuit of Q280 positive, which back biases and turns off CR275. CR285 remains forward biased, and couples the CH 1 trigger signal to the base of Q275. In the COMP mode of trigger operation, +15 volts is applied to the anode of CR280 through COMP Source switch S72B and R282. CR280 is now forward biased, pulling the cathode of CR280 positive, which back biases and turns off CR285. CR275 remains forward biased and couples the amplified COMP trigger signal present in the collector circuit of Q280 to the base of Q275. R274 and R284 set the DC level at the collector of Q275 to zero volts for no-signal, zero-volt input level conditions.

Q275 and Q278 comprise an emitter-coupled comparator amplifier. Q275 by itself is a feedback amplifier, with R285 providing feedback from the collector to the base of Q275. The DC level at the base of Q278 determines the DC level at the base of Q275.

Trigger Source

The TRIGGER SOURCE switches S72A and S72B select the source of the trigger signal. Four trigger sources are available: CH 1, COMP, external, and line. EXT ATTEN switch S70 provides 10 times attenuation for the external trigger signal. The internal trigger signals (CH 1 and COMP) are obtained from the Trigger Pickoff circuit discussed above.

The line trigger signal is obtained from the secondary of transformer T1115 in the Power Supply Primary circuit. This sample of the line frequency, about .7 volt RMS, is

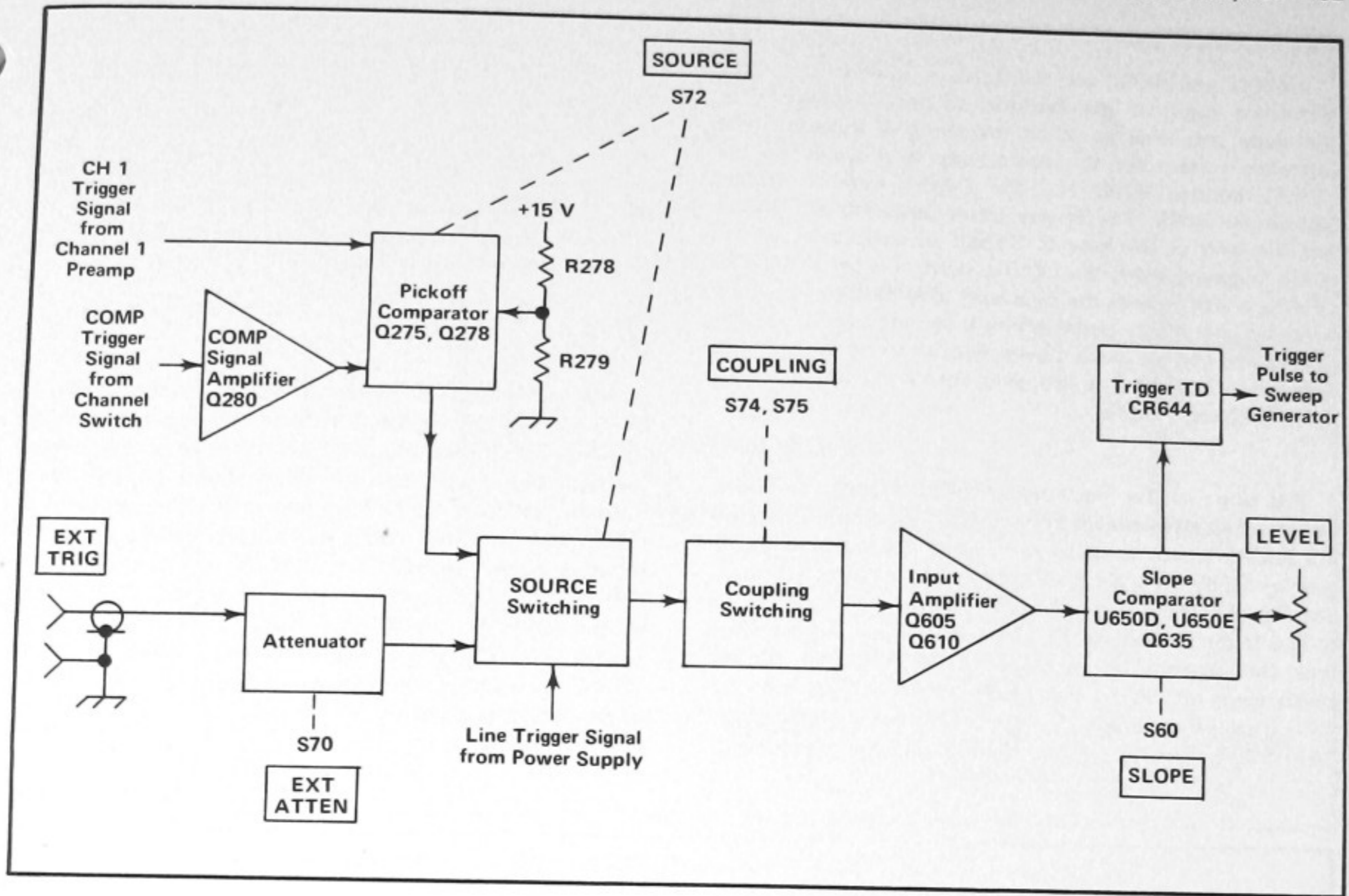

Fig. 3-8. Trigger Pickoff and Generator detailed block diagram.

coupled to the Trigger Generator circuit in the LINE mode of operation. The TRIGGER COUPLING switches should not be in the LF REJ mode of operation when using this trigger source, as the signal will be blocked by the LF reject circuit.

External trigger signals applied to the EXT TRIG input connector can be used to trigger the Sweep Generator in the EXT TRIG mode of operation. Input resistance at DC is about one megohm paralleled by about 100 picofarads (about 70 picofarads when EXT ATTEN switch S70 is in the 1:10 position). Setting the EXT ATTEN switch to the 1:10 position attenuates the input signal by a factor of 10 to provide more LEVEL control range, while maintaining the one megohm input resistance characteristic.

Trigger Coupling

The TRIGGER COUPLING switches S74, S75A, and S75B offer a means of accepting or rejecting certain components of the trigger signal. In the AC and LF REJ mode of trigger coupling, the DC component of the trigger signal is blocked by coupling capacitor C72 or C74. Frequency components below about 60 hertz are attenuated when

using AC coupling and below about 50 kilohertz when using LF REJ coupling. The higher-frequency components of the trigger signal are passed without attenuation.

In the HF REJ mode of trigger coupling, the trigger signal is DC coupled to the input if the AC and LF REJ pushbuttons are not also depressed. High-frequency components of the trigger signal (above about 50 kilohertz) are attenuated, while the lower-frequency components are passed without attenuation. The DC mode of trigger coupling passes all signals from DC to 25 megahertz.

Input Source Follower

The Input Source Follower, Q605A, provides a high input impedance for the trigger signal. It also provides isolation between the Trigger Generator circuit and the trigger signal source. Diode CR603 protects Q605A if an excessive negative input voltage is applied to the EXT TRIG input connector. The output at the anode of VR605 is connected to emitter follower stage Q610. Q605B is a relatively constant current source for Q605A, and provides temperature compensation of Q605A.

Slope Comparator

U650D and U650E are connected as an emitter-coupled difference amplifier (comparator) to provide selection of the slope and level at which the sweep is triggered. The reference voltage for the comparator is provided by the LEVEL control R60B and the Trigger Level Centering adjustment R629. The Trigger Level Centering adjustment sets the level at the base of U650E so the display is correctly triggered when the LEVEL control is centered. The LEVEL control varies the base level of U650E to select the point on the trigger signal where triggering occurs. Diodes CR615 and CR616 prevent overdrive occurring in the Slope Comparator. Q618 is a relatively constant current source for U650D and U650E.

The slope of the input signal which triggers the Sweep Generator is determined by the SLOPE switch S60. When the SLOPE switch is set to +, +5 volts is connected to the base of Q635 through R635 and to the anode of CR634. See Fig. 3-9. This forward biases CR634, which turns on and pulls the cathode of CR634 positive also. At the same time the base-emitter junction of Q635 is zero biased, which turns off Q635. With Q635 turned off, its collector falls to a level of about +2 volts set by the voltage divider R637-R638. This back biases CR635, and the trigger signal

in the collector circuit of U650D is allowed to pass to the Trigger TD CR644. The trigger signal in the collector circuit of U650E is conducted by CR634 and blocked from reaching the Trigger TD by back-biased diode CR632. The trigger signal in the collector circuit of U650D is amplified and inverted with respect to the input trigger signal. Since the output pulse from the Trigger Generator is derived from the negative-going portion of the signal applied to the Trigger TD, the sweep is triggered on the positive-going slope of the input trigger signal.

When the SLOPE switch is set to -, conditions are reversed. The base of Q635 is returned to ground through R634 and R635. See Fig. 3-10. This back biases CR634 and forward biases the base-emitter junction of Q635 sufficiently to drive Q635 into saturation. The collector of Q635 rises to within about 0.2 volt of the emitter, which forward biases CR635. Now CR630 is back-biased and CR632 is forward biased, allowing the trigger signal present in the collector circuit of U650E to be applied to the Trigger TD. The trigger signal in the collector circuit of U650E is in phase with respect to the input trigger signal, so the sweep is triggered on the negative-going slope of the input trigger signal.

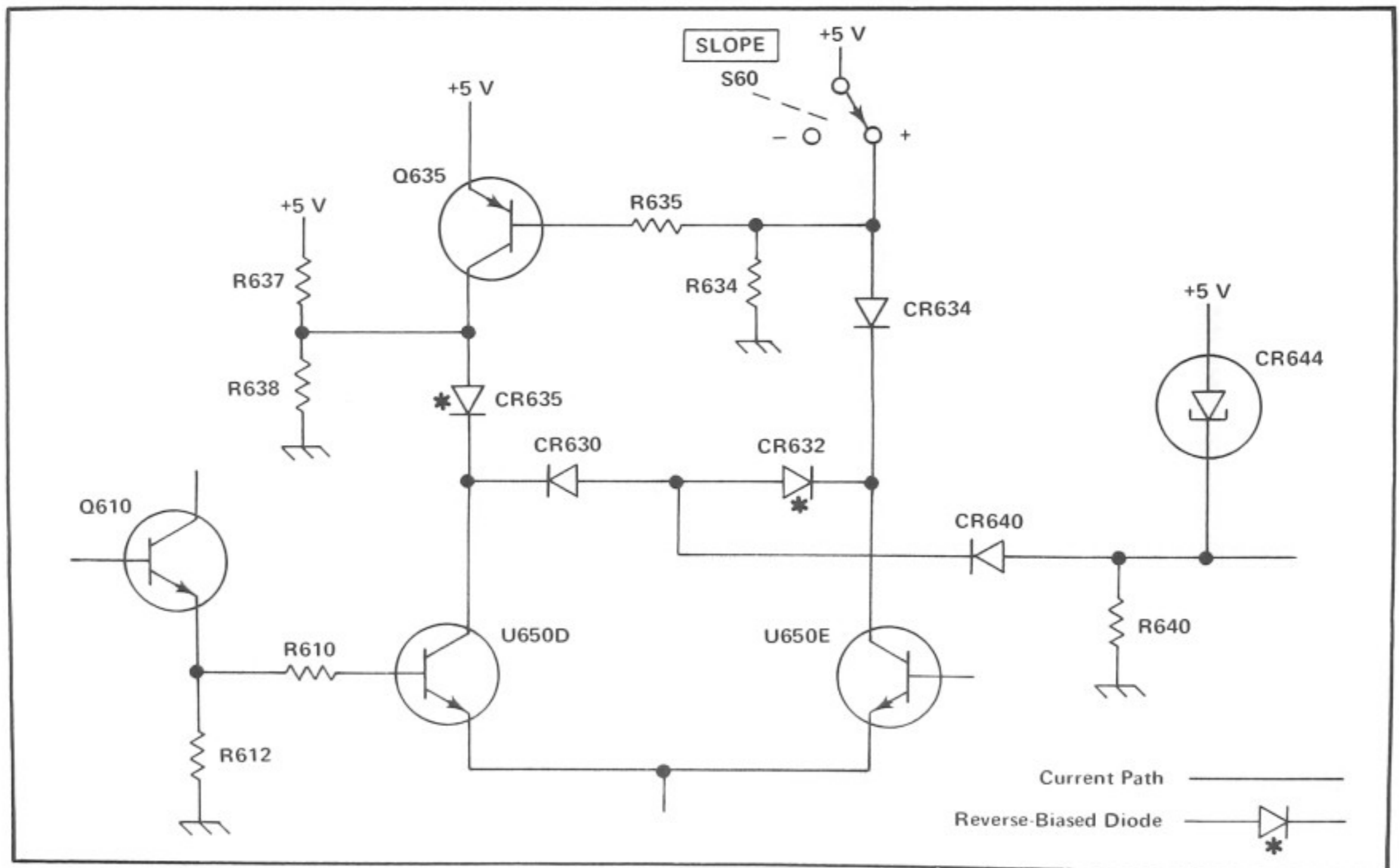

Fig. 3-9. Trigger signal path for positive-slope triggering (simplified Trigger Generator diagram).

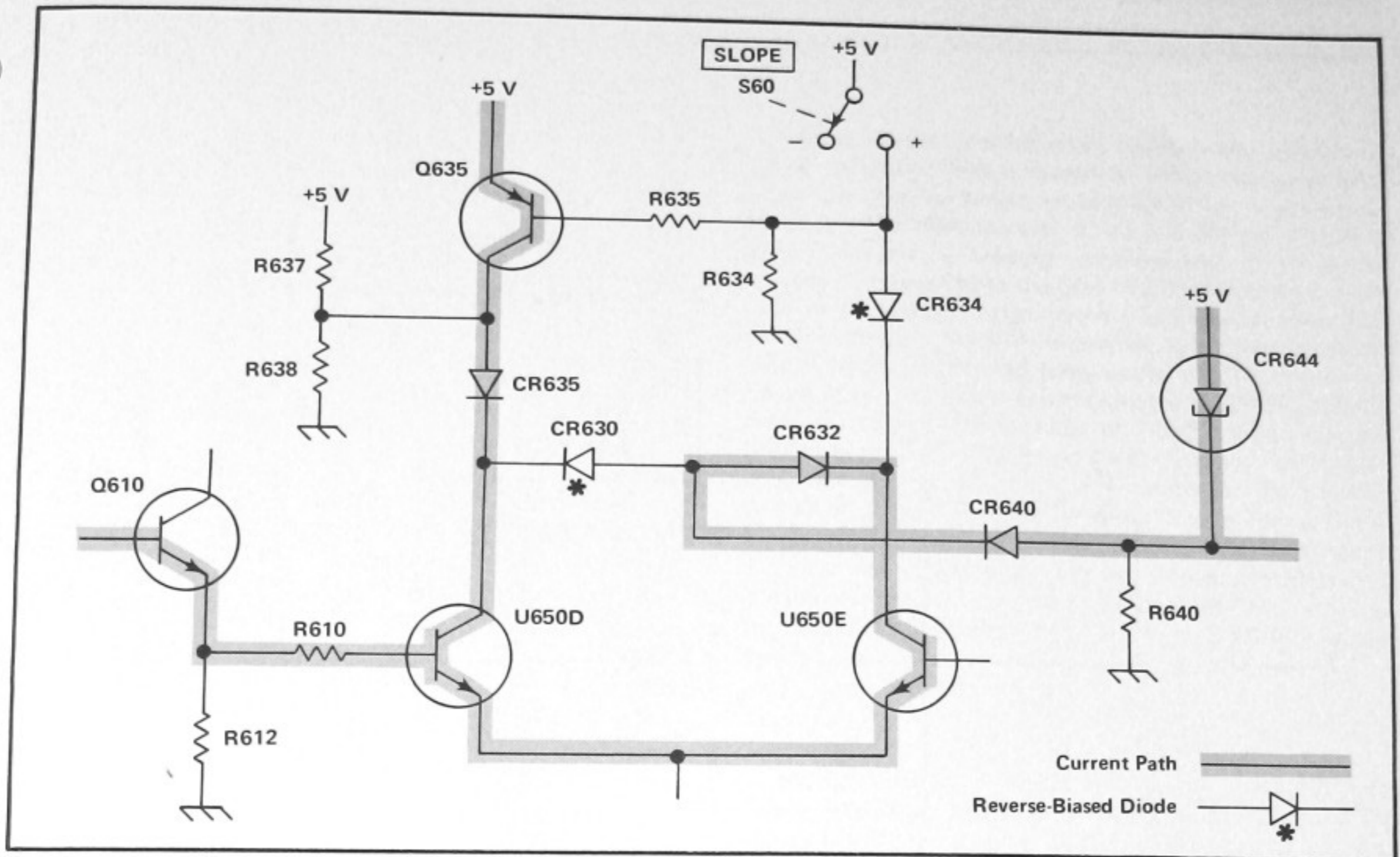

Fig. 3-10. Trigger signal path for negative-slope triggering (simplified Trigger Generator diagram).

Trigger TD

The Trigger TD stage shapes the output of the Slope Comparator to provide a trigger pulse with a fast leading edge. Tunnel diode CR644 is quiescently biased so it is on and in its low-voltage stage. The current from one of the transistors in the Slope Comparator stage is diverted through the Trigger TD stage. As the current increases due to a change in the trigger signal, tunnel diode CR644 switches to its high-voltage state. The tunnel diode remains in this condition until the current from the Slope Comparator stage decreases due to a change in the trigger signal applied to the input. Then the current through CR644 decreases and it reverts to its low-voltage state.

tor circuit. A schematic of this circuit is shown on diagram 6 at the back of this manual.

The Sweep MODE switch allows three modes of operation. In the NORM mode, a sweep is produced only when a trigger pulse is received from the Trigger Generator circuit. Operation in the AUTO mode is much the same as NORM, except that a free-running trace is displayed in the absence of an adequate trigger signal. In the SINGLE SWEEP mode, operation is also similar to NORM except that the sweep is not recurrent. The following circuit description is given with the sweep MODE switch set to NORM. Differences in operation for the other two modes are discussed later.

SWEEP GENERATOR

General

The Sweep Generator circuit produces a sawtooth voltage which is amplified by the Horizontal Amplifier circuit to provide horizontal sweep deflection on the CRT. This output signal is generated on command (trigger pulse) from the Trigger Generator circuit. The Sweep Generator also produces an unblanking gate to unblank the CRT during sweep time and an alternate trace sync gate to switch vertical channels during sweep retrace time. Fig. 3-11 shows a detailed block diagram of the Sweep Genera-

Normal Sweep Mode Operation

Sweep Gate. The negative-going trigger pulse generated in the Trigger Generator circuit is applied to the Sweep Gate stage through inverting amplifier Q645 and C663-R663. CR678 is quiescently biased on in its low-voltage state. When the positive-going trigger pulse is applied to the anode of CR678, the current through the tunnel diode increases and it rapidly switches to its high-voltage state, where it remains until reset by the Sweep Reset Multivibrator stage at the end of the sweep. The positive-going level at the anode of CR678 is connected to

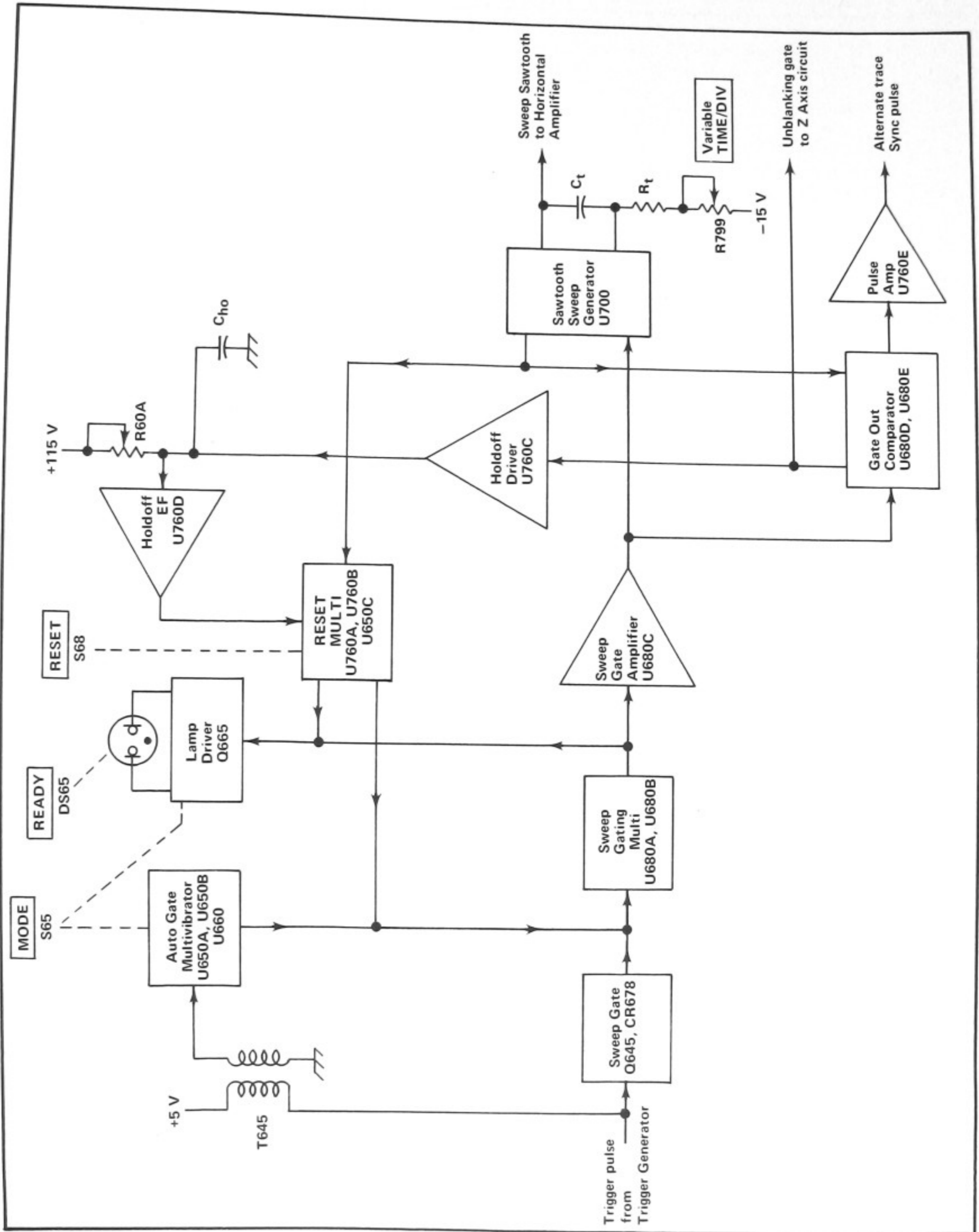

Fig. 3-11. Sweep Generator detailed block diagram.

the base of U680A through R680. U680A is turned on and its collector goes negative. This negative-going step is connected to the base of U680B through C686-R686. U680B is turned off and its collector goes positive. This positive-going step is connected to the base of the Sweep Gate Amplifier.

Sweep Gate Amplifier. The Sweep Gate Amplifier U680C is an emitter follower quiescently conducting current through R742, R796, R794, R692, and R690. When sweep triggering occurs, the positive-going excursion at the base of U680C is present in the emitter circuit and is applied to pin 1 of the Sawtooth Sweep Generator U700 and the base of U680D.

Gate Output Comparator. The positive-going signal at the base of U680D turns U680D on, and turns U680E off. The negative-going excursion at the collector of U680D is applied to the emitter of Holdoff Driver U760C, and is also coupled to the Z-Axis circuit through R790, CR794, and CR795 to unblank the CRT during sweep time. At the same time that the collector of U680D is going negative, the collector of U680E is going positive. This positive-going voltage is applied to the base of the Alternate Trace Sync Pulse Emitter Follower U760E.

Holdoff Driver. The negative-going signal at the collector of U680D when the sweep begins is connected to the Holdoff Capacitor through U760C. This negative-going signal discharges the Holdoff Capacitor completely at the start of each sweep to provide accurate sweep holdoff time. CR785 clamps the collector of U760C so it does not go more negative than about -0.5 volt.

Sawtooth Sweep Generator. The basic sweep generator is a Miller Integrator circuit. When pin 1 of U700 is positive, the timing capacitor, C_T , begins to charge through the timing resistor, R_T . The timing resistor and capacitor are selected by the TIME/DIV switch S700 to provide the various sweep rates listed on the front panel. Diagram 8 shows a complete diagram of the TIME/DIV switch. The Sweep Cal adjustment R727 allows calibration of this circuit for accurate sweep timing. The Variable TIME/DIV control R799 provides continuously variable uncalibrated sweep rates by varying the charge rate of the timing capacitor. R703 is an Offset adjustment to adjust the quiescent DC level at pin 9 of U700 to zero volts. This reduces timing current errors between positions of the TIME/DIV switch.

The output sawtooth voltage signal at pin 8 of U700 is applied to the Horizontal Amplifier input. Voltage divider R705-R706 determines the amplitude of the sawtooth ramp. When the ramp reaches this predetermined level, a reset pulse is generated at pin 4 of U700. This reset pulse is applied to the base of U760A in the Sweep Reset Multi-

vibrator and to the base of U680E in the Gate Output Comparator.

Sweep Reset Multivibrator. Quiescently, U760A is turned off and U760B is turned on. The sweep reset pulse (a narrow, positive-going, rectangular pulse) is applied to the base of U760A through R700 and CR710. U760A is turned on and its collector goes negative. This negative movement is coupled to the base of U760B and turns it off, causing its collector to go positive. The positive movement at the collector of U760B is coupled to the base of U650C which, prior to this, had been turned off. The increase in forward bias of the base-emitter junction of U650C drives it into saturation. The collector of U650C moves negative until it is only a few tenths of a volt more positive than the grounded emitter. The negative movement of the collector of U650C is coupled to the anode of Sweep Gating Tunnel Diode CR678 through R678, causing CR678 to switch from its high-voltage state to a low-voltage state where it is conducting almost no current. As long as U650C is turned on, CR678 is prevented from switching to its high voltage state.

Holdoff Emitter Follower. When the sweep reset pulse causes U760A and U760B to reverse states, the pulse also causes U680E and U680D in the Gate Output Comparator to switch states. The reset pulse turns on U680E which causes U680D to turn off. The positive movement at the collector of U680D when it turns off causes U760C to turn off and the Holdoff Capacitor, C_{HO} , starts to charge positive through R778 and R60A. This positive movement is coupled through Holdoff Emitter Follower U760D and emitter resistor R774 to the anode of diode CR765. When sufficient forward bias is achieved, CR765 will turn on and couple the positive-going movement to the base of U760B in the Sweep Reset Multivibrator, causing U760B to turn on and U760A to turn off. The negative movement at the collector of U760B turns U650C off and CR678 conducts current in its low-voltage state, ready to receive the next trigger pulse.

R60A varies the charge rate of the Holdoff Capacitor to provide a stable display at fast sweep rates. This change in holdoff allows sweep synchronization for less display jitter at the faster sweep rates, and has very little effect at slow sweep rates. R60A is ganged with the TRIGGER LEVEL control and is adjusted by rotating the LEVEL knob. The Holdoff Capacitor is changed by the TIME/DIV switch for the various sweep rates to provide the correct holdoff time.

Auto Sweep Mode Operation

Operation of the Sweep Generator circuit in the AUTO mode is the same as for the NORM mode just described when an adequate trigger pulse is present. However, when an adequate trigger pulse is not present, a free-running

Circuit Description—432

reference trace is produced in the AUTO mode. This occurs as follows:

Auto Multivibrator. U650A and U650B form a monostable multivibrator. Quiescently with no trigger pulses being generated by the Trigger Generator circuit, U650B is conducting and U650A is biased off by only about 150 millivolts. With U650A not conducting, its collector moves positive, which forward biases CR660 allowing Q660 to conduct. Q660 conducts its current through R646, C663-R663, and Sweep Gating Tunnel Diode CR678. The added current through tunnel diode CR678 automatically switches it to its high-voltage state at the end of the sweep holdoff period. The result is that the Sweep Generator circuit is automatically retriggered at the end of each holdoff period, and a free-running sweep is produced. Since the sweep free-runs at the sweep rate of the Sweep Generator, a bright reference trace is produced even at fast sweep rates.

When trigger pulses are being produced by the Trigger Generator circuit, positive-going pulses are coupled to the base of U650A by transformer T645. These positive pulses turn on U650A, which causes U650B to turn off. The collector of U650A goes negative and the collector of U650B goes positive, which combines to turn off CR660 and Q660. When U650A turned on and its collector went negative, capacitor C650 discharged very rapidly. If the multivibrator does not receive another trigger pulse, C650 will recharge to approximately +15 volts in about 115 milliseconds. The auto gate level at the collector of transistor Q660 will be negative when the Trigger Generator circuit is producing trigger pulses, and positive when the Trigger Generator circuit is not producing trigger pulses. In both the NORM and SINGLE SWEEP modes of operation, -15 volts is applied to the anode of CR660 through R660 to back bias CR660 and prevent Q660 from conducting.

Single Sweep Mode Operation

General. Operation of the Sweep Generator in the SINGLE SWEEP mode of operation is similar to operation in the other modes. However, after one sweep has been produced, the Sweep Reset Multivibrator stage does not reset. All succeeding trigger pulses are locked out until the RESET button is pushed.

In the SINGLE SWEEP mode of operation, -15 volts is applied to the top of READY light DS65 and to the emitter of CR770. CR770 is forward biased and holds CR765 back biased to prevent the Sweep Reset Multivibrator from resetting at the end of the sweep holdoff time.

Single-Sweep Reset. The Single Sweep Reset circuit produces a pulse to reset the Sweep Reset Multivibrator stage so another sweep can be produced in the SINGLE SWEEP mode of operation. After a sweep has been pro-

duced in the SINGLE SWEEP mode, U760A is on and U760B is off. Pressing the RESET pushbutton applies +15 volts to the voltage divider made up of R784, R783, and R782. C782 capacitively couples a positive-going spike to the anode of CR765. CR765 becomes forward biased and turns on, coupling the positive-going spike to the base of U760B. U760B now turns on and U760A turns off. When U760B turns on, its collector goes negative, which turns Q665 off and also turns U650C off, allowing the Sweep Gating Tunnel Diode CR678 to accept the next trigger pulse.

When Q665 turns off, its collector goes positive, allowing sufficient voltage to be impressed across READY light DS65 to turn the READY light on. This indicates that the Sweep Generator is ready to produce a sweep upon receipt of the next trigger pulse. When the next trigger pulse is received, the collector of U680B in the Sweep Gating Multivibrator will go positive and turn on Q665. The collector of Q665 will go negative, causing the READY LIGHT to turn off.

HORIZONTAL AMPLIFIER

General

The Horizontal Amplifier circuit provides the output signal to the CRT horizontal deflection plates. The signal applied to the input of the Horizontal Amplifier is determined by the TIME/DIV switch. The signal can be a sawtooth waveform generated internally within the instrument, or some external signal applied to the EXT HORIZ input connector located on the instrument rear panel. The Horizontal Amplifier circuit also contains the horizontal magnifier circuit and the horizontal positioning network. Fig. 3-12 shows a detailed block diagram of the Horizontal Amplifier circuit. A schematic of this circuit is shown on diagram 7 at the rear of this manual.

Input Paraphase Amplifier

The input signal for the Horizontal Amplifier is selected by the TIME/DIV switch, S700A. In all positions of the switch except EXT HORIZ, the sawtooth from the Sweep Generator circuit is connected to the base of Input Amplifier Q825A. In the EXT HORIZ position of the switch, the signal applied to the base of Q825A is obtained from the EXT HORIZ input connector.

Q825A and Q825B comprise an emitter-coupled paraphase amplifier. This stage converts the single-ended input signal to a push-pull signal necessary to drive the horizontal deflection plates of the CRT. R816, R817, R826 and R827 control the emitter degeneration between Q825A and Q825B to set the gain of the stage. The adjustment of R817 determines overall horizontal amplifier gain. Q818 is a constant current source for Q825A and Q825B. Horizontal positioning is provided by the POSITION control (R55A-

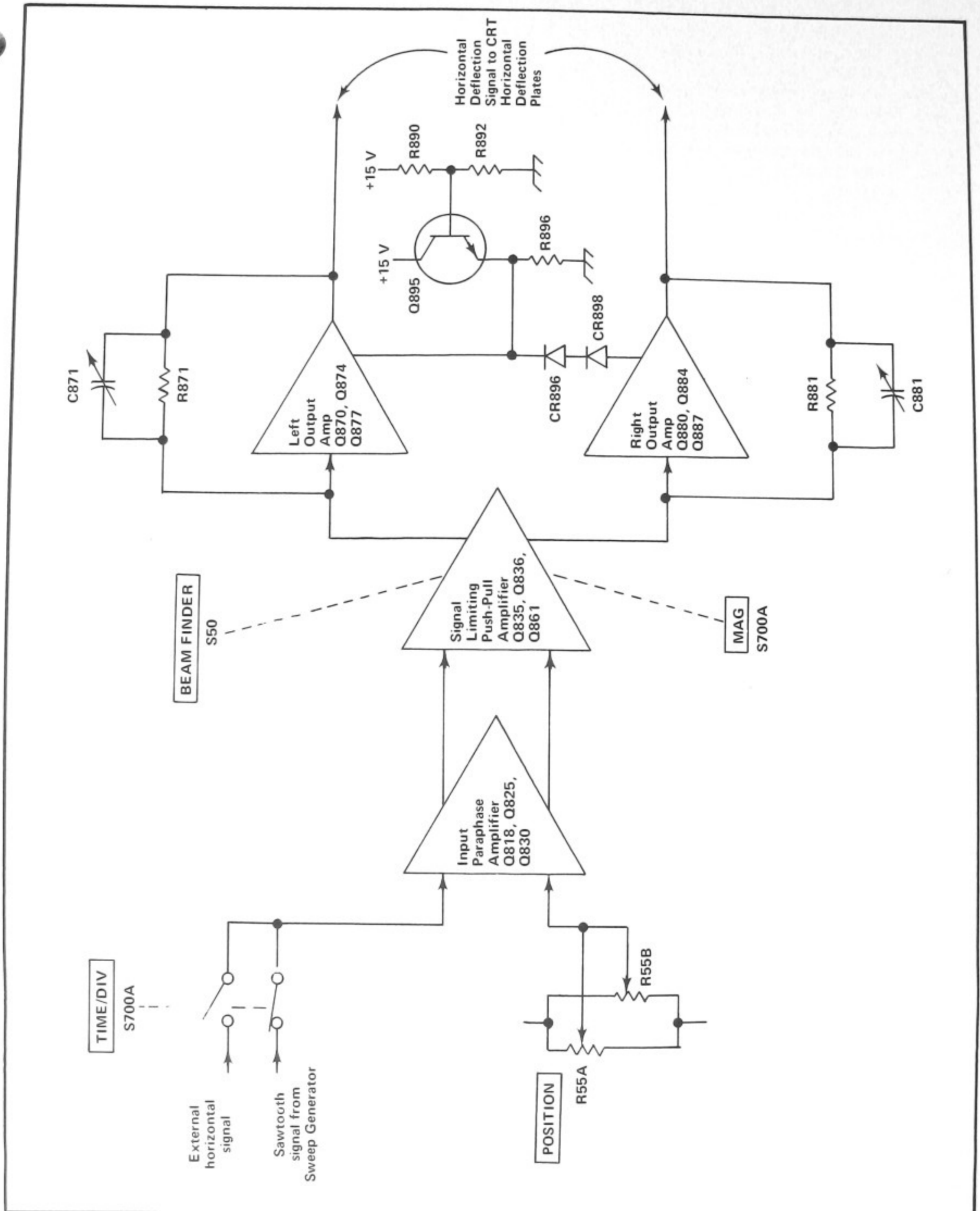

Fig. 3-12. Horizontal Amplifier detailed block diagram.

Circuit Description—432

R55B) connected to the base of Q825B. This control is a dual-range control to provide a combination of coarse and fine adjustment in a single control. When the control is rotated, fine control R55B provides positioning for a range of about 0.3 major division for a normal (unmagnified) display. Then after the fine range is exceeded, the coarse control R55A provides rapid positioning of the trace. The output signals from the collectors of Q825A and Q825B are applied to the bases of emitter followers Q830A and Q830B respectively.

Signal Limiting Push-Pull Amplifier

Q835 and Q836 form a push-pull amplifier stage with Q835A and Q836A comprising a cascade amplifier in one side and Q835B and Q836B a cascade amplifier in the other side. Sweep magnification is accomplished by modifying the gain setting resistance between the emitters of Q835A and Q835B. CR835 and CR865 limit the difference in signal amplitude between the bases of emitter followers Q836A and Q836B. This prevents amplifier over-drive when the sweep is magnified or positioned to one extreme or the other. CR836 and CR866 provide additional overdrive protection.

Q861 is a relatively constant current source for Q835 and Q836. When the BEAM FINDER push-button is pushed the current through Q861 is reduced by approximately two milliamperes. This reduces the dynamic range of the signal limiting push-pull amplifier stage, thereby limiting the trace to within the CRT graticule area. The Magnifier Registration adjustment R868 balances the quiescent DC current to the bases of Q870 and Q880 so a centerscreen display does not change position when the sweep is magnified.

Output Amplifier

The push-pull output of the Signal Limiting Push-Pull Amplifier stage is connected to the Output Amplifier through CR870 and CR880. Each half of the Output Amplifier can be considered as a single-ended feedback amplifier which amplifies the signal current at the input to produce a voltage output to drive the horizontal deflection plates of the CRT. The amplifiers have a low input impedance and require very little voltage change at the input to produce the desired output change.

Q895 is a relatively constant voltage source. The base of Q895 is biased to set the emitter at approximately +5 volts and the anode of CR898 at approximately +6.5 volts. This sets the base of Q880 and the base of Q870 very near the same quiescent DC level. CR870 and CR880 become back biased and are turned off when overdrive in the positive direction occurs at their cathodes.

Transistors Q870 and Q880 are inverting amplifiers whose collector signals drive the emitters of complementary

amplifiers Q874-Q877 and Q884-Q887 respectively. The output signal from complementary amplifier Q874-Q877 drives the left horizontal deflection plate of the CRT, and the output signal from complementary amplifier Q884-Q887 drives the right horizontal deflection plate. C871 and C881 adjust the transient response of the amplifier so it has good linearity at fast sweep rates.

POWER SUPPLY PRIMARY

General

The Power Supply Primary circuit provides controlled drive to the primary of power transformer T1085 to achieve more efficient generation of secondary voltages. This circuit also contains the circuitry necessary to regulate the secondary voltages against change due to variations in input line voltage or frequency, or changes in power supply load. Figure 3-13 shows a detailed block diagram of the Power Supply Primary circuit. A schematic of this circuit is shown on diagram 9 at the rear of this manual.

Line Input

Power is applied to this circuit through Line Fuse F1000, R1002, Thermal Cutout S1002, Line Filter FL1010, and POWER switch S1010. Resistor R1002 limits the amplitude of surge currents at instrument turn-on. Thermal cutout S1002 provides thermal protection for the instrument. If the internal temperature of the instrument exceeds a safe operating level, S1002 opens to interrupt the applied power. When the temperature returns to a safe level, S1002 closes to re-apply the power.

The Line Filter made up of C1004, C1006, L1004, R1004, and T1004 is designed primarily to suppress the 25-kilohertz interference originating within the power supply. L1004 provides differential and common-mode inductance; T1004 provides additional common-mode inductance. Common-mode filtering is provided by C1005 and C1006 along with the common-mode inductance of T1004. R1004 provides common-mode damping for C1004-C1006-T1004.

When the POWER switch S1010 is closed, line voltage is applied to the primary of transformer T1115 and to the full-wave bridge-rectifier CR1016. T1115 provides a sample of the AC line-voltage to the Trigger Generator circuit for operation in the LINE triggering mode. CR1016 rectifies the AC line voltage into a DC voltage to be used in the Power Supply Primary circuit. C1016 provides a measure of filtering to the remaining AC component. R1016 discharges C1016 when instrument power is turned off. Transformer T1036 provides additional 25-kilohertz filtering.

Start Circuit

The rectified DC power is applied initially to the Power Supply Primary Circuit by the Start Circuit made up of

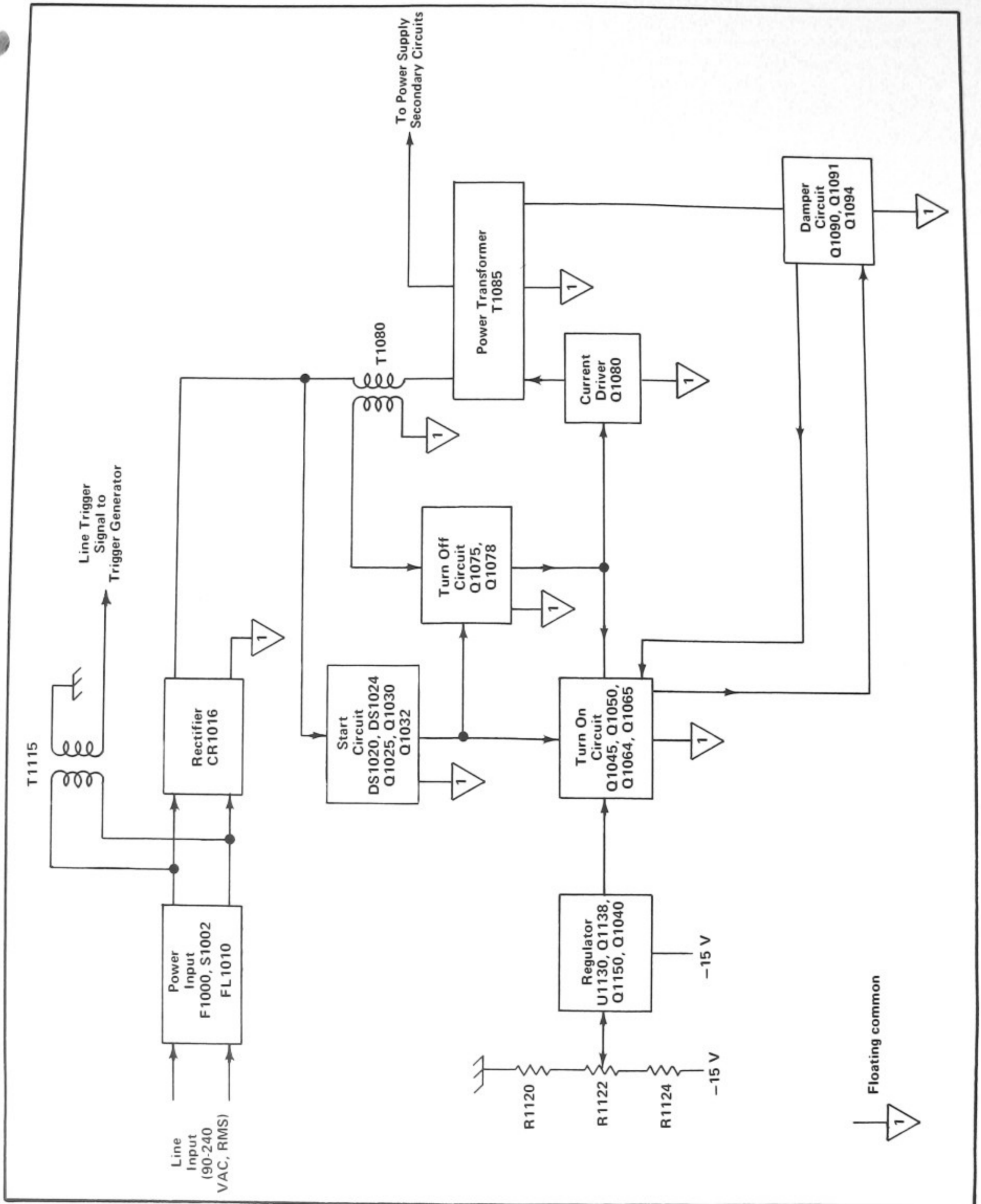

Fig. 3-13. Power Supply detailed block diagram.

Circuit Description—432

DS1020, DS1024, Q1025, Q1030, Q1032 and their associated circuitry. DS1020, DS1024, C1024, R1020, and R1024 form a relaxation oscillator with a very low repetition rate (waveform period of approximately 5 seconds). When DS1024 is on and DS1020 is off, the base-emitter junction of Q1025 is forward biased, causing Q1025 to conduct. The collector circuit of Q1025 moves negative (very near the floating common potential) causing the base-emitter junctions of Q1030 and Q1032 and the diode CR1032 to be back-biased, preventing them from conducting.

When DS1020 is on and DS1024 is off, conditions are reversed. Q1025 is off and its collector rises to an approximately +51 volt level (with respect to the floating common) determined by zener diode VR1025. Q1030, Q1032, and CR1032 conduct, causing the junction of CR1032 and R1034 to rise to an approximately +50 volt level. This establishes a temporary V_{CC} voltage supply for the Turn On and Turn Off circuits in lieu of the normal V_{CC} voltage supplied by one winding of T1085 and half-wave rectifier CR1085. Normal circuit operation now takes place and a sufficiently positive V_{CC} voltage is generated to back-bias and prevent CR1032 from conducting.

Current Driver

The Current Driver stage, Q1080, controls the current conducted through the primary winding of Power Transformer T1085. Q1080 is in turn controlled by signal pulses from the Turn On and Turn Off circuits. Quiescently Q1080 is biased off, and must receive a positive-going pulse at its base from the Turn On circuit in order to conduct current through T1085. The Turn Off circuit monitors the current conducted through T1085 and generates a turn-off pulse when a preset maximum level of current is reached. Zener diodes VR1084 and VR1085 prevent the collector of Q1080 from going more than 250 volts more positive than the reference level at the anode of VR1085. This reference level will be dependent upon the value of line voltage applied to the instrument. This clamping action prevents exceeding the emitter to collector breakdown voltage rating of Q1080 during transformer flyback time when Q1080 is turned off, and also aids in regulation of the negative high voltage power supply.

Turn On Circuit

The Turn On circuit generates the pulse required to cause Q1080 to turn on and conduct current through the primary of T1085. With an adequate V_{CC} voltage supply at the emitter of Q1045, Q1045 will be biased into saturation. The collector of Q1045 will be within about 0.2 volt of the emitter. C1046 starts to charge toward this positive level through R1046. When the charge on C1046 reaches a level about 0.6 volt more positive than the level at the gate of Q1050, Q1050 will turn on and start to conduct current to discharge C1046 and, at the same time, forward bias the

base-emitter junction of Q1064. When the current flow through Q1050 falls below the level necessary to keep Q1050 on, Q1050 will turn off and C1046 will start to charge again.

When Q1050 turns on, Q1064, which is quiescently biased off, starts to conduct current through the parallel combination of R1064 and the primary winding of transformer T1064. T1064 couples a positive-going movement to the emitter of Q1065. This positive movement is coupled back to the base of Q1064 through CR1060, R1060, and R1062, which reinforces the turn-on bias of Q1064. The positive movement at the emitter of Q1065 turns it on, which causes a positive pulse to be coupled to the base of Q1080 through CR1068 and R1068. Q1080 now turns on and starts to conduct current through the primary winding of T1085.

Turn Off Circuit

To prevent Q1080 from conducting excessive amounts of current, the Turn Off circuit monitors the amount of current flowing in the primary winding of T1085, and generates a turn-off pulse when a preset current level is reached. The secondary winding of T1080 develops a voltage across R1075 and Current Sense Adjustment R1074. When this voltage level becomes about 0.6 volt more positive than the voltage level at the gate of Q1075, Q1075 turns on and conducts current through R1076, CR1075, and the secondary winding of T1080. The resulting positive movement at the cathode of Q1075 is coupled through C1076 to the base of Q1078.

Q1078 now turns on and conducts current through the parallel combination of R1078 and the primary winding of T1078. The negative movement at the collector of Q1078 is coupled through R1071, C1071, and CR1070 to the base of Q1064 in the Turn On circuit to interrupt the turn-on process while the Turn Off circuit is trying to stop conduction through Q1080. Transformer T1078 couples a negative-going pulse through CR1078 and CR1079 to the base of Q1080. The negative-going pulse at the base of Q1080 is of sufficient amplitude to cause reverse current to flow through the base-emitter junction of Q1080, and insure rapid turn-off. CR1081 and CR1082 clamp the base of Q1080 at an approximate -4 volt level during transformer flyback.

Damping Circuit

When the Current Driver stage Q1080 is turned off and stops conducting current through T1085, the magnetic field in T1085 collapses very rapidly. After this flyback time, high amplitude ringing is generated in T1085. Q1090, Q1091, and Q1094 and their associated circuitry make up a damper circuit designed to suppress this ringing.

When the Turn On circuit generates the turn-on pulse for Q1080, the negative movement at the collector of Q1064 is coupled through C1093, CR1092, and R1095 to the base of Q1091. The resultant narrow negative-going pulse at the base of Q1091 starts to turn off Q1091 and Q1094. The positive movement at the collector of Q1065 is also coupled back to the Damping Circuit and applied to the base of Q1090 through CR1090 and R1090. Q1090 turns off, and its collector goes negative, which serves to hold Q1091 and Q1094 off.

When Q1080 is turned off, its collector steps positive to a level determined by the clamping action of VR1085 and VR1084. T1085 transforms this into a negative movement at the cathode of CR1091 to hold Q1091 and Q1094 off. The negative movement at the collector of Q1065 is applied to the base of Q1090 through CR1090 and R1090, turning Q1090 on. About five to ten microseconds after the turn-off time of Q1080, flyback ends, ringing occurs in T1085 and CR1091 turns off. Q1091 and Q1094 are turned on by Q1090 and conduct very heavily through the full-wave bridge rectifier CR1096-CR1099 and one winding of T1085 to reduce the amplitude of the ringing. The damping transistors Q1091 and Q1094 thus conduct only during the time flyback ringing is occurring.

C1095, CR1095, and the transformer winding connected to the cathode of CR1095 form a half-wave rectifier power supply generating approximately -5 volts to be used in the Damping Circuit.

Regulator Circuit

The Regulator Circuit holds the outputs of the Power Supply relatively constant despite variations in input line voltage, line frequency, and load demand. Regulation is accomplished by varying the time interval between current pulses conducted in the primary winding of T1085 by Q1080.

C1136 and R1132 comprise a timing circuit to determine the interval between the regulating pulses. C1136 charges toward the voltage level at pin 6 of U1130 through R1132 and CR1132. When the charge on C1136 reaches a level about 0.6 volt more positive than the voltage level at the gate of Q1138, Q1138 conducts current to discharge C1136 and, at the same time, forward biases the base-emitter junction of Q1150. When the current flow through Q1138 falls below the level necessary to keep Q1138 on, Q1138 will turn off and C1136 will start to charge again.

When Q1138 turns on, Q1150, which is quiescently biased off, turns on and conducts a current pulse through the primary winding of T1150. T1150 couples a negative-going pulse to the base of Q1040 through CR1040. Q1040 turns on and its collector moves positive to turn on Q1050,

which starts the sequence of events necessary to generate a turn-on pulse for Q1080.

The time interval between pulses generated in the Regulator circuit is altered by monitoring variations in the -15 volts supply. For example, when heavy load demands are being made on the -15 volt supply it attempts to go positive. This positive movement results in a positive movement in the voltage level at pin 6 of U1130. A more positive level at pin 6 of U1130 shortens the amount of time required by C1136 to charge to the level at which Q1138 turns on. This results in more turn-on pulses being generated for Q1080, thereby increasing the amount of energy transferred through T1085 per unit of time.

POWER SUPPLY SECONDARY

General

The Power Supply Secondary circuit rectifies the AC voltages present in the secondary windings of Power Transformer T1085 to provide the necessary DC supply voltages to the instrument circuitry. A schematic of this circuit is shown on diagram 10 at the rear of this manual.

Rectifier Circuits

All of the rectifier circuits in the Power Supply Secondary are half-wave rectifiers. LII02, LII04, and LII06 provide added filtering for the $+115$ volt, $+15$ volt, and the -15 volt supplies respectively. T1100 provides common-mode inductance to suppress the 25-kilohertz interference originating in the power supply circuit. The High-Voltage supply is a series of ten half-wave rectifier power supplies. Total output voltage of the supply is approximately 4.1 kilovolts for use in the CRT circuit. CR1199 provides DC filament voltage to the CRT.

CRT CIRCUIT

General

The CRT Circuit contains the control circuitry necessary for operation of the cathode-ray tube (CRT). Fig. 3-14 shows a detailed block diagram of the CRT circuit. A schematic of this circuit is shown on diagram 11 at the rear of this manual.

Unblanking Amplifier

The Unblanking Amplifier circuit controls the CRT intensity level from several inputs. The effect of these input signals is to either increase or decrease the trace intensity, or to completely blank portions of the display. A portion of integrated circuit U940A is used to convert the voltage signals present at the amplifier inputs into current variations to drive the output portion of the Unblanking

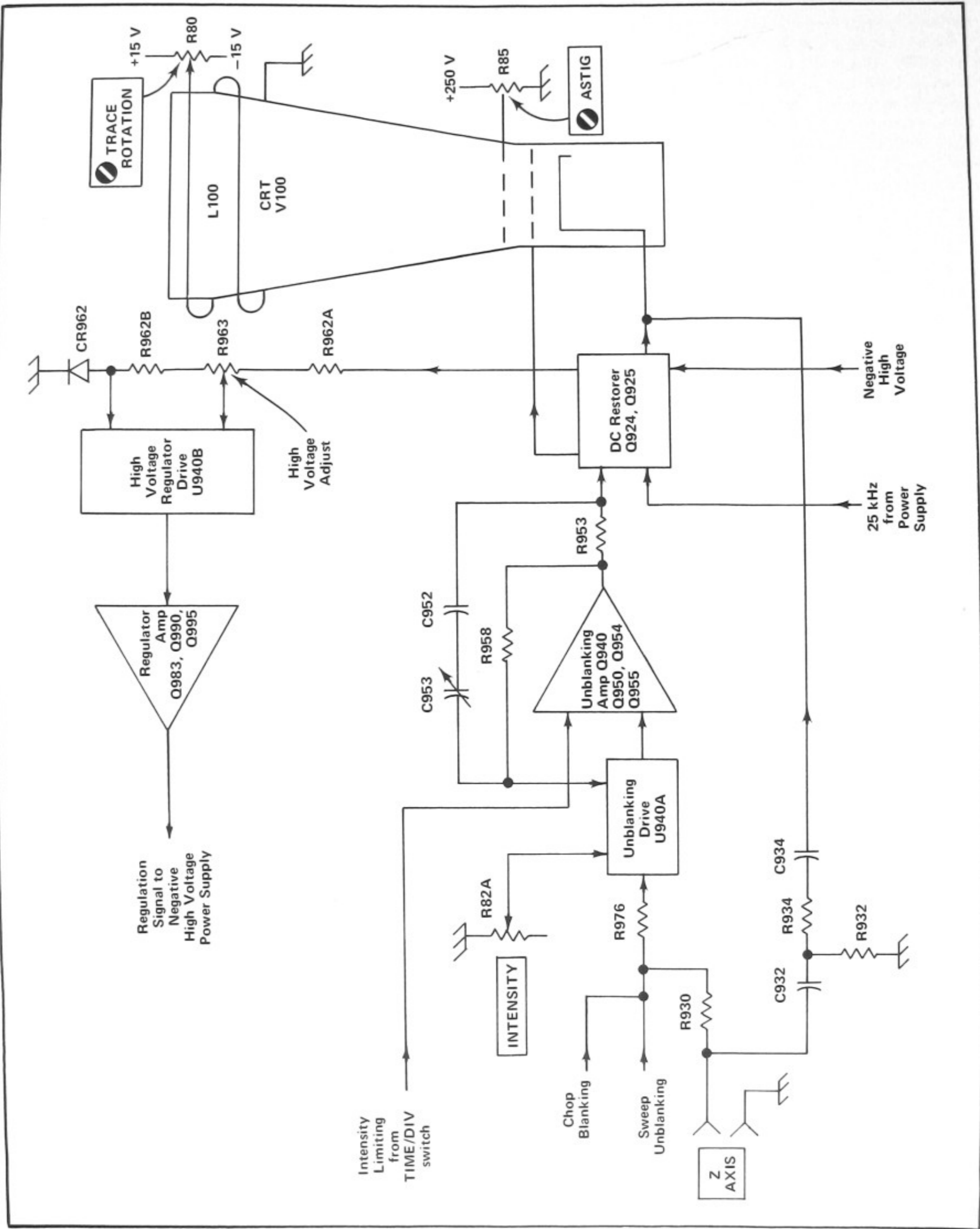

Fig. 3-14. CRT Circuit detailed block diagram.

Amplifier. CRT intensity variations are accomplished in the following manner.

When a sweep starts, the DC level present at pin 2 of U940A steps negative, resulting in a reduced current flow from pin 9 of U940A. This reduction in current increases the forward bias on Q954 and reduces the forward bias on Q955. Q954 conducts harder, resulting in a positive movement at the emitter of Q954. This positive movement is coupled through C942 to the emitter of Q940 and starts a positive movement at the collector of Q940. At the same time that this is occurring, Q955 is decreasing its conduction through R955 and Q950, which causes a positive movement to occur at the collector of Q950, which reinforces and sustains the positive movement started by Q940. At the end of the sweep, conditions are reversed. The DC level at pin 2 of U940A steps positive, causing increased current flow from pin 9 of U940A and the collectors of Q940 and Q950 move negative. The variations in DC level at the collectors of Q940 and Q950 are connected to the DC Restorer circuit.

To reduce the possibility of burning the CRT phosphor, the emitter voltage of Q940 is changed by the TIME/DIV switch, S700A. In the 50 ms/DIV position and up, the TIME/DIV switch applies +115 volts to the junction of R943 and VR944. In all switch positions below 50 ms/DIV, +115 volts is no longer connected to the junction of R943 and VR944. Instead, the emitter of Q940 is returned to +115 volts through R942, R943, and VR944. This produces a less positive level at the emitter of Q940 to limit the collector level of Q940 and Q950 which protects the CRT phosphor in these switch positions.

DC Restorer Circuit

Q924 and Q925 form a complementary amplifier, each side of which conducts on a half cycle of the waveform coupled through T920 from the secondary of the power supply transformer. The voltage on the collector of Q924 is determined by the output of the Unblanking Amplifier. On the positive half cycle, Q924 saturates and the common emitters seek the Q924 collector voltage. On the negative half cycle, Q925 saturates and the common emitters go to ground potential.

C924, C925, CR926, CR928, and R928 form a DC restorer network. All DC voltage levels in this circuit are referenced to the negative high-voltage potential. The voltage difference across R928 approximately equals the voltage swing present on the common emitters of Q924 and Q925. The upper end of R928 is more positive than the lower end, but negative with respect to the CRT cathode. Varying the drive signal to the Unblanking Amplifier changes the voltage level at the amplifier output, which in turn varies the amplitude of the voltage swing on the

common emitters of Q924 and Q925, thereby resulting in changes to the CRT bias. CR924 and CR925 limit the positive excursion that can occur at the collector of Q924 and the common emitters of Q924 and Q925 respectively. CRT Grid Bias adjustment R980 determines the level of the range of adjustment of the INTENSITY control. CR935 provides protection to the CRT if the grid tries to rise more positive than the cathode.

High Voltage Regulator

Feedback from the high-voltage circuit is connected to pin 20 of integrated circuit U940B. Any change in this sample of the high-voltage level produces an in-phase error signal at pin 17 of U940B which is amplified and inverted through Q989, Q990, and Q995. Regulation occurs as follows:

If the negative high-voltage level attempts to go positive (less negative), a sample of this positive-going voltage is applied to pin 20 of U940B. This results in a positive-going error signal at pin 17 of U940B which is applied to the base of Q989 through CR982. Q989 amplifies and inverts this error signal, which receives further amplification through Q990 and Q995. The resulting negative movement at the collector of Q995 is applied to the positive pole of the minus high-voltage supply, and is of sufficient amplitude to maintain the output level of the supply.

VR985 through VR990 prevent more than 900 volts from appearing across Q989, Q990, and Q995 to prevent exceeding the maximum voltage rating of these devices in the event of circuit failure. CR983 prevents the base of Q989 from going more negative than about -0.5 volt. R963 adjust the negative high-voltage power supply for the proper output voltage.

CRT Control Circuits

Focus of the CRT display is determined by the Focus control R82B. This control is part of voltage divider R962C, R968, R82B, R83, R962D, R962E between the negative high-voltage and ground. Therefore, the voltage applied to the focus grid is more positive (less negative) than the voltage on either the control grid or cathode. R968 sets the range of adjustment of the Focus control. The Focus control is ganged with the front-panel INTENSITY control, and is automatically adjusted when changes are made in the INTENSITY setting. The ASTIG adjustment R85, which is also adjusted to obtain a well-defined display, varies the positive level on the astigmatism grid. Geometry adjustment R967 varies the positive level on the horizontal deflection plate shield to control the overall geometry of the display. The TRACE ROTATION adjustment R80 controls the current through L100, which varies the magnetic field around the CRT to horizontally align the CRT trace.

CALIBRATOR

General

The Calibrator circuit produces a square-wave output with accurate amplitude and frequency. This output is available as a square-wave voltage at the PROBE CAL 0.6 V 1 kHz connector. Fig. 3-15 shows a detailed block diagram of the Calibrator circuit. A schematic of this circuit is shown on diagram 11 at the back of this manual.

Multivibrator

Q905 and Q910 along with their associated circuitry comprise an astable multivibrator. Basic frequency of the multivibrator is determined by the RC combination of

R906, R910, and C906. R904 provides a measure of adjustment of Calibrator frequency.

In the Calibrator Multivibrator, Q905 and Q910 are never both conducting at the same time. Assume for purposes of explanation that Q905 has just turned off and Q910 has turned on. When Q905 turns off, its collector moves positive, which also pulls the base of Q910 positive. This positive movement turns Q910 on and charges C906 positive. Immediately, the emitter of Q905 begins to discharge toward -15 volts. When the Q905 side of C906 has discharged sufficiently to forward bias the base-emitter junction of Q905, Q905 turns on and its collector moves negative. The negative movement at the collector of Q905 turns off Q910. Now the emitter circuit of Q910 begins to discharge toward -15 volts. When the Q910 side of C906 has discharged sufficiently to forward bias the base-emitter junction of Q910, Q910 turns on. At the time Q910 turns on, a positive movement is coupled from the emitter of Q910 to the emitter of Q905 by C906. This positive movement at the emitter of Q905 reduces the current flow through Q905, causing a reinforcing positive movement at the base of Q910. Q905 rapidly turns off as Q910 turns on. The square wave signal at the collector of Q910 is connected to the Output Amplifier.

Output Amplifier

The output signal from the Calibrator Multivibrator stage overdrives Q915 to produce an accurate square wave at the output. When the base of Q915 goes positive, Q905 is cut off and the output signal drops negative to ground. When the base goes negative, Q915 is driven into saturation and the collector of Q915 rises positive to about $+15$ volts. The output voltage is connected from the voltage divider R915-R916-R918 to the PROBE CAL 0.6 V 1 kHz connector. R915 adjusts the overall ratio of the voltage divider to provide an accurate output voltage amplitude.

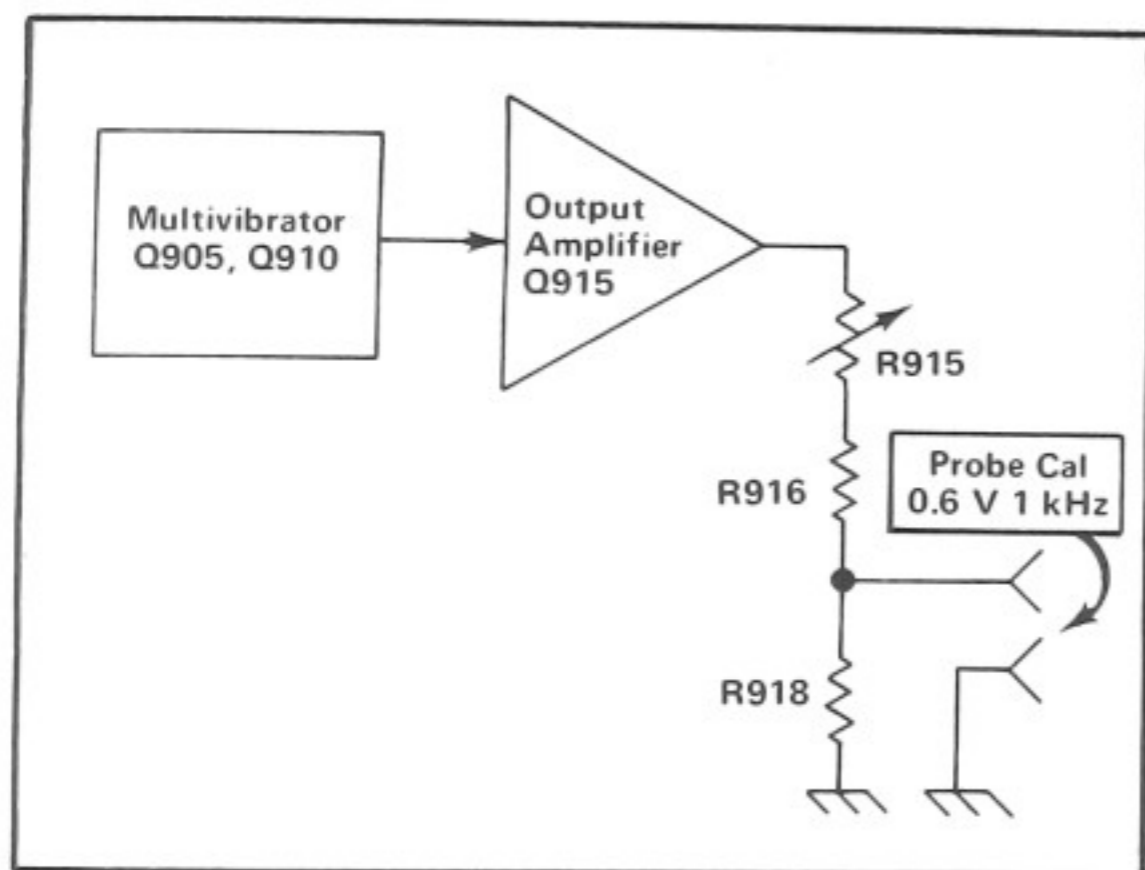

Fig. 3-15. Calibrator detailed block diagram.

SECTION 4

MAINTENANCE

Change information, if any, affecting this section will be found at the rear of the manual.

Introduction

This section of the manual contains maintenance information for use in preventive maintenance, corrective maintenance or troubleshooting of the 432.

Cabinet Removal

WARNING

Dangerous potentials exist at several points throughout this instrument. When the instrument is operated with the covers removed, do not touch exposed connections or components. The Primary Power Supply shield is at power line potential and some transistors may have elevated cases. Disconnect power before cleaning the instrument or replacing parts. Use an isolation transformer for safety when troubleshooting or adjusting power supply circuits.

The cabinet can be removed from the oscilloscope as follows:

1. Unwrap the power cord from the instrument feet.
2. Loosen the phillips-head screw located in each instrument foot. See Fig. 4-1.
3. Remove the rear ring assembly from the rear of the instrument.
4. Slide the cabinet to the rear and remove the oscilloscope.

The R432 can be removed from its cabinet in a similar manner. To replace the instrument in its wrap-around cabinet, reverse the removal procedure. The portable wrap-around cabinet should be installed with the carrying handle pivot points positioned toward the bottom of the instrument.

PREVENTIVE MAINTENANCE

General

Preventive maintenance consists of cleaning, visual inspection, lubrication, etc. Preventive maintenance

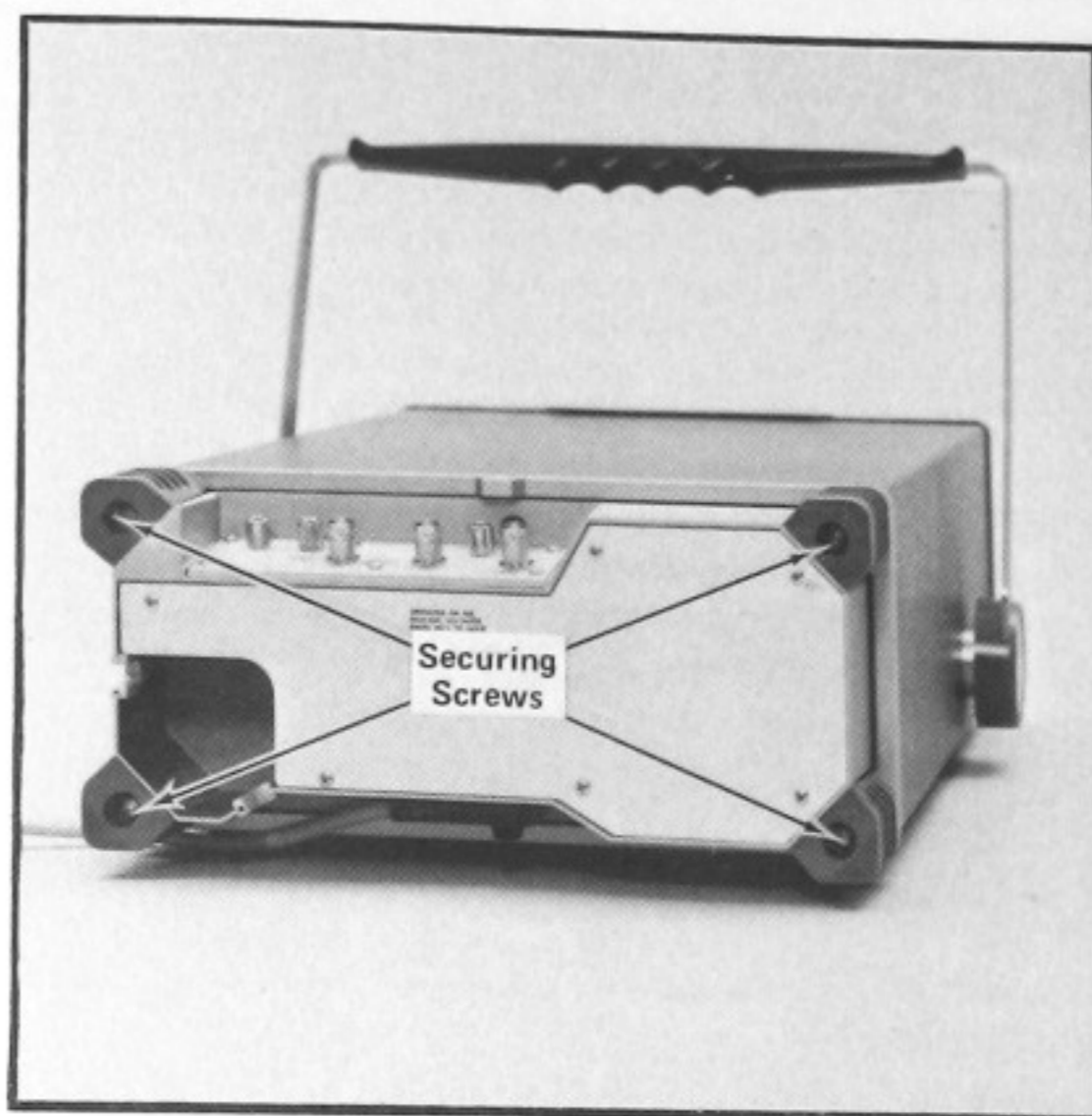

Fig. 4-1. Removing wrap-around cabinet.

performed on a regular basis may prevent instrument breakdown and will improve the reliability of this instrument. The severity of the environment to which the 432 is subjected determines the frequency of maintenance. A convenient time to perform preventive maintenance is preceding recalibration of the instrument.

Cleaning

General. The 432 should be cleaned as often as operating conditions require. Accumulation of dirt in the instrument can cause overheating and component breakdown. Dirt on components acts as an insulating blanket and prevents efficient heat dissipation. It also provides an electrical conduction path which may result in instrument failure.

The cabinet provides protection against dust in the interior of the instrument. Operation without the cabinet in place necessitates more frequent cleaning. The front cover provides dust protection for the front panel and the CRT face. The front cover should be installed for storage or transportation.

CAUTION

Avoid the use of chemical cleaning agents which might damage the plastics used in this instrument. Avoid chemicals which contain benzene, toluene, xylene, acetone or similar solvents.

Exterior. Loose dust accumulated on the outside of the 432 can be removed with a soft cloth or small paint brush. The paint brush is particularly useful for dislodging dirt on and around the front-panel controls. Dirt which remains can be removed with a soft cloth dampened in a mild detergent and water solution. Abrasive cleaners should not be used.

CRT. Clean the blue plastic light filter and the CRT face with a soft, lint-free cloth dampened with denatured alcohol or a mild detergent and water solution. The optional CRT mesh filter can be cleaned in the following manner.

1. Hold the filter in a vertical position and brush lightly with a soft No. 7 watercolor brush to remove light coatings of dust and lint.
2. Greasy residues or dried-on dirt can be removed with a solution of warm water and a neutral pH liquid detergent. Use the brush to lightly scrub the filter.
3. Rinse the filter thoroughly in clean water and allow to air dry.
4. If any lint or dirt remains, use clean low-pressure air to remove. Do not use tweezers or other hard cleaning tools on the filter, as the special finish may be damaged.
5. When not in use, store the mesh filter in a lint-free dust-proof container such as a plastic bag.

Interior. Dust in the interior of the instrument should be removed occasionally due to its electrical conductivity under high-humidity conditions. The best way to clean the interior is to blow off the accumulated dust with dry, low-pressure air. Remove any dirt which remains with a soft paint brush or a cloth dampened with a mild detergent and water solution. A cotton-tipped applicator is useful for cleaning in narrow spaces or for cleaning circuit boards.

Lubrication

The potentiometers, cam switches and pushbutton switches used in this instrument are factory lubricated and should not require further lubrication for the normal life of the components.

Transistor Checks

Periodic checks of the transistors in the 432 are not recommended. The best check of transistor performance is actual operation in the instrument. More details on checking transistor operation are given under Troubleshooting.

Recalibration

To assure accurate measurements, check the calibration of this instrument after each 1000 hours of operation or every six months if used infrequently. In addition, replacement of components may necessitate recalibration of the affected circuits. Complete calibration instructions are given in the Calibration section.

The calibration procedure can also be helpful in localizing certain troubles in the instrument. In some cases, minor troubles may be revealed and/or corrected by recalibration.

TROUBLESHOOTING

Introduction

The following information is provided to facilitate troubleshooting of the 432. Information contained in other sections should be used along with the following information to aid in locating the defective component. An understanding of the circuit operation is very helpful in locating troubles. See the Circuit Description section for complete information.

Troubleshooting Aids

Diagrams. Complete circuit diagrams are given on fold-out pages in the Diagrams section. The component number and electrical value of each component in this instrument are shown on the diagrams. Important voltages and waveforms are also shown on the diagrams. The portions of the circuit mounted on the circuit boards are enclosed with a blue line.

Circuit Boards. Figs. 8-1 through 8-22 in the Diagrams section show the circuit boards used in the 432. Fig. 4-5 shows the location of each board within the instrument. Each electrical component on the boards is identified by its circuit number. These pictures, used along with the diagrams, aid in locating the components mounted on the circuit boards.

Wiring Color-Code. All insulated wire and cable used in the 432 is color-coded to facilitate circuit tracing. Table 4-1 gives the wiring color-code for the power-supply voltages used in this instrument.

TABLE 4-1
Power Supply Wiring Color Code

Supply	Background Color	Stripe
-15 volt	Purple	Black
+15 volt	Red	Black
+115 volt	Red	Brown
+250 volt	Red	Orange

Resistor Color-Code. In addition to the brown composition resistors, metal-film resistors and some wire-wound resistors are used in the 432. The resistance of a wire-wound resistor is printed on the body of the component. The resistance values of composition resistors and metal-film resistors are color-coded on the components with EIA color-code (some metal-film resistors may have the value printed on the body). The color-code is read starting with the stripe nearest the end of the resistor. Composition resistors have four stripes which consist of two significant figures, a multiplier and a tolerance value (see Fig. 4-2). Metal-film resistors have five stripes consisting of three significant figures, a multiplier and a tolerance value.

Capacitor Marking. The capacitance values of common disc capacitors and small electrolytics are marked in microfarads on the side of the component body. The white ceramic capacitors used in the 432 are color coded in picofarads using a modified EIA code (see Fig. 4-2).

Diode Color-Code. The cathode end of each glass-encased diode is indicated by a stripe, a series of stripes or a dot. For most silicon or germanium diodes with a series of

Composition Resistors: (Diagram showing 4 bands: 1, 2, M, T)

Metal-Film Resistors: (Diagram showing 5 bands: 1, 2, 3, M, T)

Ceramic Capacitors: (Diagram showing 5 bands: TC, 1, 2, M, T)

① ② and ③ —1st, 2nd and 3rd significant figures;
 (M) —multiplier; (T) —tolerance;
 (TC) —temperature coefficient.

Resistor and Capacitor Color Code

Color	Significant Figures	Multiplier		Tolerance	
		Resistors	Capacitors	Resistors	Capacitors
Silver	---	10 ⁻²	---	±10%	---
Gold	---	10 ⁻¹	---	±5%	---
Black	0	1	1	---	±20% or 2 pF*
Brown	1	10	10	±1%	±1% or 0.1 pF*
Red	2	10 ²	10 ²	±2%	±2%
Orange	3	10 ³	10 ³	±3%	±3%
Yellow	4	10 ⁴	10 ⁴	±4%	+100% -0%
Green	5	10 ⁵	10 ⁵	±0.5%	±5% or 0.5 pF*
Blue	6	10 ⁶	10 ⁶	---	---
Violet	7	---	---	---	---
Gray	8	---	10 ⁻²	---	+80% -20% or 0.25 pF*
White	9	---	10 ⁻¹	---	±10% or 1 pF*
(none)	---	---	---	±20%	±10% or 1 pF*

*For capacitance of 10 pF or less.

NOTE: (T) and/or (TC) color code for capacitors depends upon manufacturer and capacitor type. May not be present in some cases.

Fig. 4-2. Color-code for resistors and ceramic capacitors.

stripes, the color-code identifies the three significant digits of the Tektronix Part Number using the resistor color-code system (e.g., a diode color-coded pink or blue-brown-gray-green indicates Tektronix Part Number 152-0185-00). The cathode and anode ends of a metal-encased diode can be identified by the diode symbol marked on the body. See Fig. 4-3.

Semiconductor Lead Configuration. Fig. 4-4 shows the lead configurations of the semiconductors used in this instrument. This view is as seen from the bottom of the device.

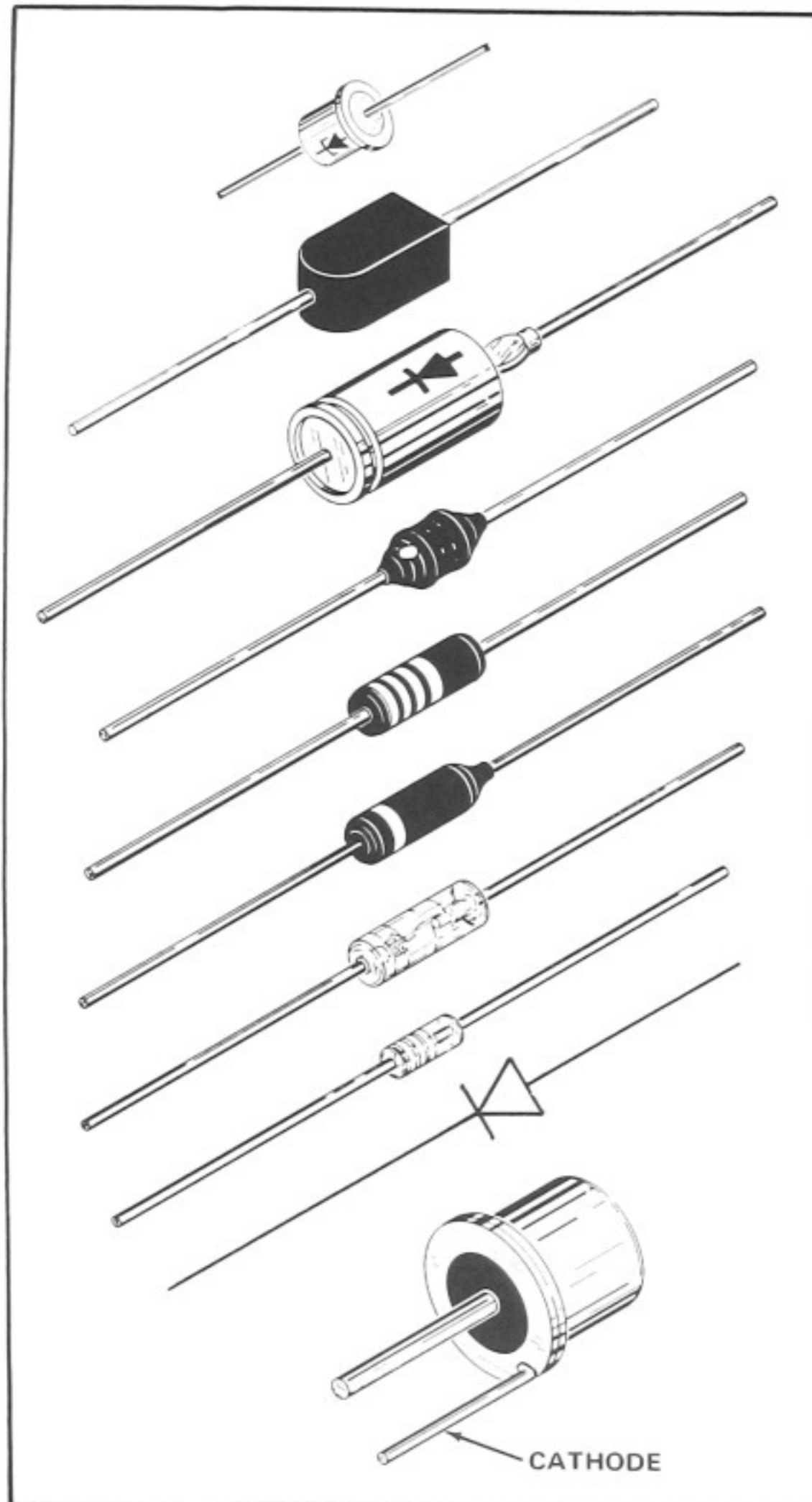

Fig. 4-3. Diode polarity markings.

Troubleshooting Equipment

The following equipment is useful for troubleshooting the 432.

1. Transistor Tester

Description: Tektronix Type 575 or 576 Transistor-Curve Trace or equivalent.

Purpose: To test semiconductors used in this instrument more precisely than VOM check.

2. Multimeter

Description: VTVM, 10 megohm input impedance, 0 to 5000 volts DC and 0 to 300 volts AC range; ohmmeter, 5 ohms to 500 k Ω center scale. Accuracy, within 3%. Test probes must be insulated to prevent accidental shorting.

NOTE

A 20,000 ohms/volt VOM can be used to check the voltages in this instrument if allowances are made for the circuit loading of the VOM at high-impedance points.

Purpose: To check voltages and for general troubleshooting in this instrument.

3. Test Oscilloscope

Description: DC to 25 MHz frequency response, one millivolt to five volts/division deflection factor. A 10X probe should be used to reduce circuit loading.

Purpose: To check waveforms in this instrument.

4. Isolation Transformer

Description: Primary to secondary ratio of 1:1; 100 watt capacity and at least 600 V primary to secondary insulation.

Purpose: To isolate power input of this instrument from ground for personnel safety and to allow grounding points in the internal power supply for troubleshooting purposes.

Troubleshooting Techniques

This troubleshooting procedure is arranged in an order which checks the simple trouble possibilities before proceeding with extensive troubleshooting. The first few checks assure proper connection, operation and calibration. If the trouble is not located by these checks, the remaining steps aid in locating the defective component. When the

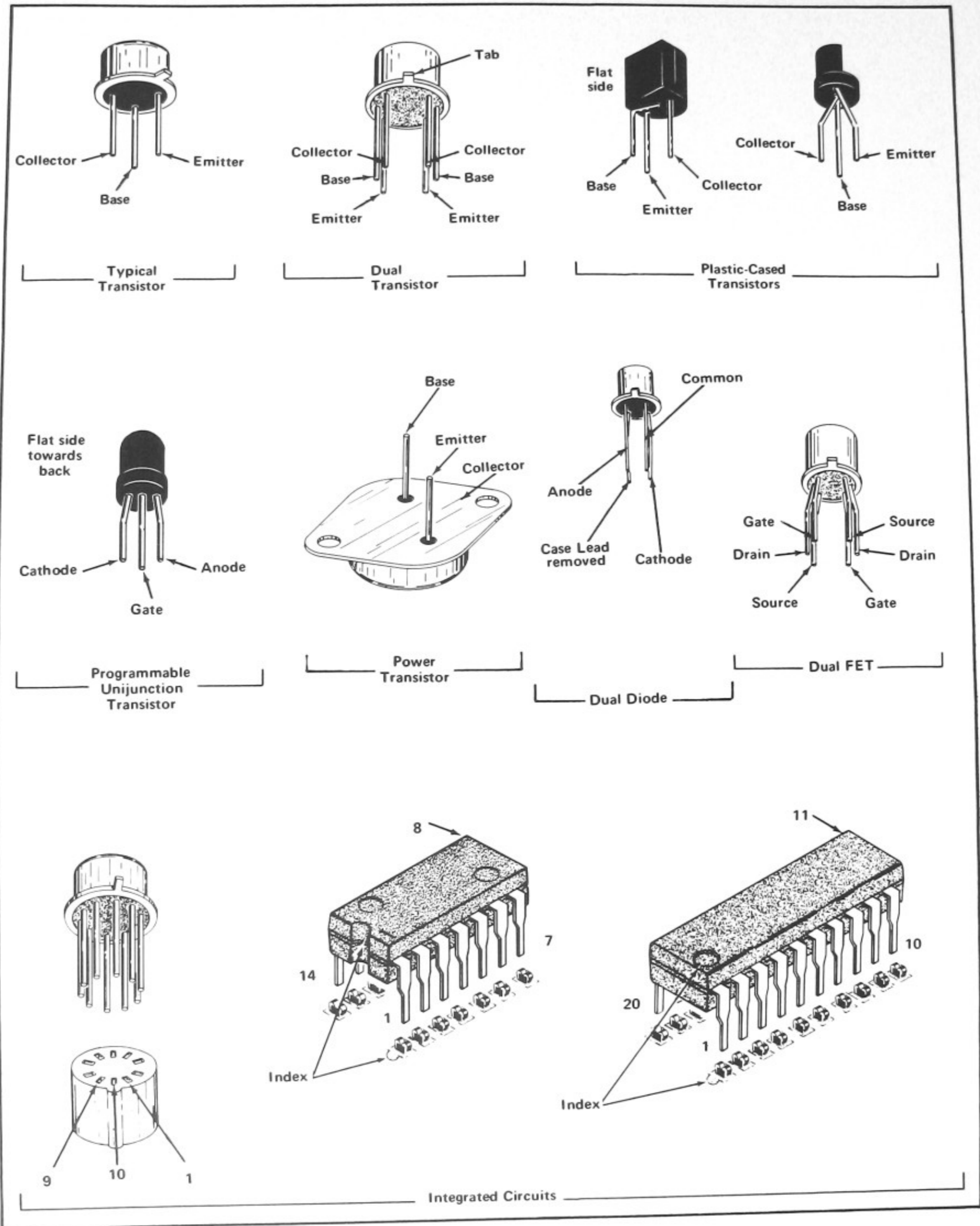

Fig. 4-4. Electrode configuration for semiconductors used in this instrument.

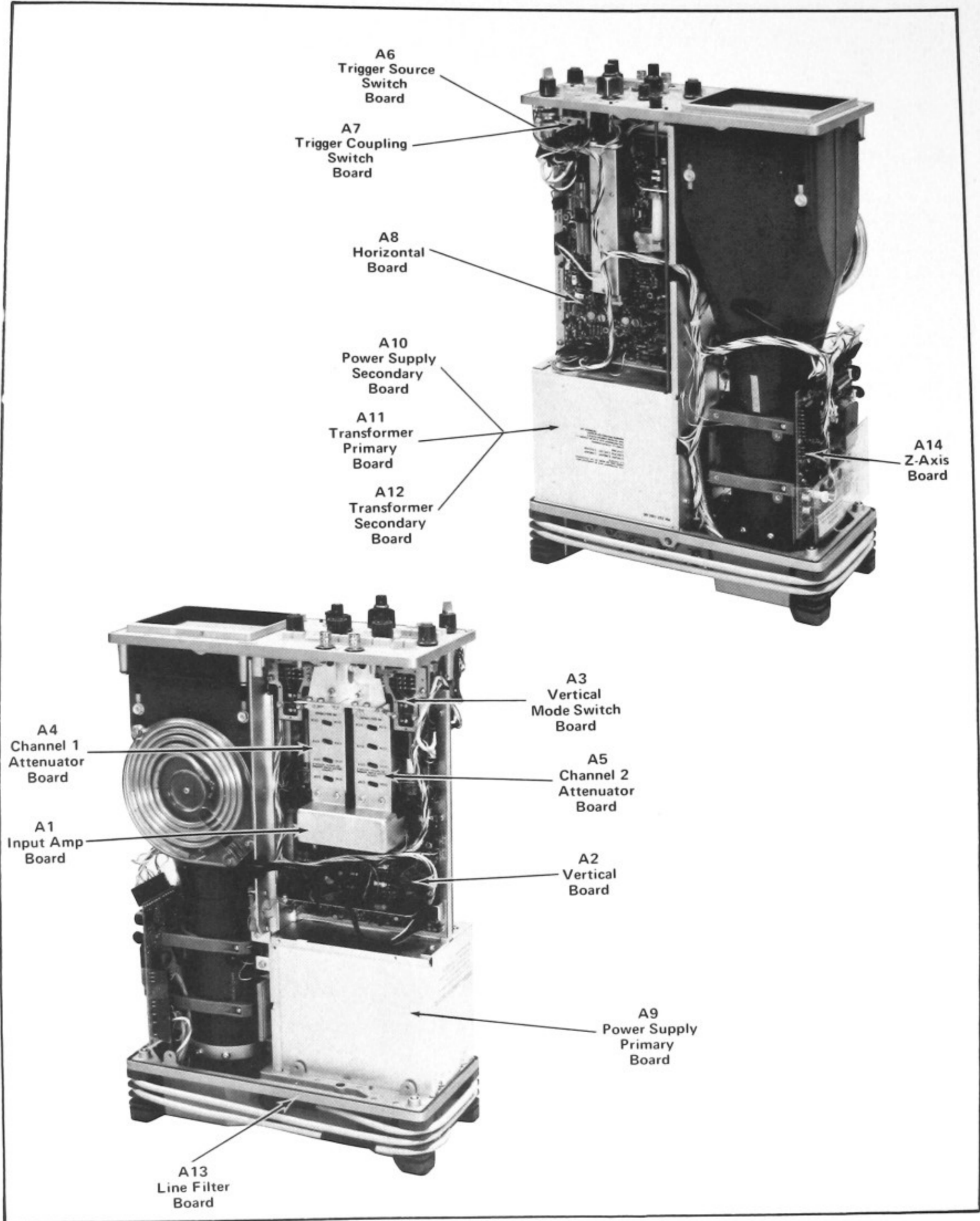

Fig. 4-5. Location of circuit boards in the 432.

defective component is located, it should be replaced following the replacement procedures given under Corrective Maintenance.

1. Check Control Settings. Incorrect control settings can indicate a trouble that does not exist. If there is any question about the correct function or operation of any control, see the Operating Instructions section.

2. Check Associated Equipment. Before proceeding with troubleshooting of the 432, check that the equipment used with this instrument is operating correctly. Check that the signal is properly connected and that the interconnecting cables are not defective. Also, check the power source.

3. Visual Check. Visually check the portion of the instrument in which the trouble is located. Many troubles can be located by visual indications such as unsoldered connections, broken wires, damaged circuit boards, damaged components, etc.

4. Check Instrument Calibration. Check the calibration of this instrument, or the affected circuit if the trouble appears in one circuit. The apparent trouble may only be a result of misadjustment or may be corrected by calibration. Complete calibration instructions are given in the Calibration section.

5. Isolate Trouble to a Circuit. To isolate trouble to a circuit, note the trouble symptom. The symptom often identifies the circuit in which the trouble is located. For example, poor focus indicates that the CRT circuit (includes high voltage) is probably at fault. When trouble symptoms appear in more than one circuit, check affected circuits by taking voltage and waveform readings.

Incorrect operation of all circuits often indicates trouble in the power supply. Check first for correct voltage of the individual supplies. However, a defective component elsewhere in the instrument can appear as a power-supply trouble and may also affect the operation of other circuits. Table 4-2 lists the tolerances of the power supplies in this instrument. If a power-supply voltage is within the listed tolerance, the supply can be assumed to be working correctly. If outside the tolerance, the supply may be misadjusted or operating incorrectly. Use the procedure given in the Calibration section to adjust the power supplies.

After the defective circuit has been located, proceed with steps 6 through 8 to locate the defective component(s).

TABLE 4-2
Power Supply Tolerance and Ripple

Power Supply	Tolerance	Maximum Ripple (Peak-to-peak)	
		Line Frequency	25 KiloHertz
-15 volt	Within 0.113 volt	10 mV	40 mV
+15 volt	Within 0.225 volt	10 mV	40 mV
+115 volt	Within 4.6 volts	0.5 volt	0.5 volt
+250 volt	-10 V +12.5 V	1 volt	1 volt

6. Check Circuit Board Interconnections. After the trouble has been isolated to a particular circuit, check the pin connectors on the circuit board for correct connection. Figs. 8-1 through 8-22 show the correct connections for each board.

The pin connectors used in this instrument also provide a convenient means of circuit isolation. For example, a short in a power supply can be isolated to the power supply itself by disconnecting the pin connectors for that voltage at the remaining boards.

7. Check Voltages and Waveforms. Often the defective component can be located by checking for the correct voltage or waveform in the circuit. Typical voltages and waveforms are given on the diagrams.

NOTE

Voltages and waveforms given on the diagrams are not absolute and may vary slightly between instruments. To obtain operating conditions similar to those used to take these readings, see the first diagram page.

8. Check Individual Components. The following procedures described methods of checking individual components in the 432. Components which are soldered in place are best checked by disconnecting one end. This isolates the measurement from the effects of surrounding circuitry.

A. TRANSISTORS. The best check of transistor operation is actual performance under operating conditions. If a transistor is suspected of being defective, it can best be checked by substituting a new component or one which has been checked previously. However, be sure that circuit conditions are not such that a replacement transistor might also be damaged. If substitute transistors are not available, use a dynamic tester (such as Tektronix Type 576). Static-

type testers are not recommended, since they do not check operation under simulated operating conditions.

CAUTION

The POWER switch must be turned off before removing or replacing transistors.

B. DIODES. A diode can be checked for an open or shorted condition by measuring the resistance between terminals. With an ohmmeter scale having an internal source of between 800 millivolts and 3 volts, the resistance should be very high in one direction and very low when the meter leads are reversed.

CAUTION

Do not use an ohmmeter scale that has a high internal current. High currents may damage the diode. Do not measure tunnel diodes with an ohmmeter; use a dynamic tester (such as a Tektronix Type 576 Transistor-Curve Tracer).

C. RESISTORS. Check the resistors with an ohmmeter. See the Electrical Parts List for the tolerance of the resistors used in this instrument. Resistors normally do not need to be replaced unless the measured value varies widely from the specified value.

D. INDUCTORS. Check for open inductors by checking continuity with an ohmmeter. Shorted or partially shorted inductors can usually be found by checking the waveform response when high frequency signals are passed through the circuit. Partial shorting often reduces high-frequency response (roll-off).

E. CAPACITORS. A leaky or shorted capacitor can best be detected by checking resistance with an ohmmeter on the highest scale. Do not exceed the voltage rating of the capacitor. The resistance reading should be high after initial charge of the capacitor. An open capacitor can best be detected with a capacitance meter or by checking whether the capacitor passes AC signals.

9. Repair and Readjust the Circuit. If any defective parts are located, follow the replacement procedures given in this section. Be sure to check the performance of any circuit that has been repaired or that has had any electrical components replaced.

CORRECTIVE MAINTENANCE

General

Corrective maintenance consists of component replacement and instrument repair. Special techniques required to replace components in this instrument are given here.

Obtaining Replacement Parts

Standard Parts. All electrical and mechanical part replacements for the 432 can be obtained through your local Tektronix Field Office or representative. However, many of the standard electronic components can be obtained locally in less time than is required to order them from Tektronix, Inc. Before purchasing or ordering replacement parts, check the parts list for value, tolerance, rating and description.

NOTE

When selecting replacement parts, it is important to remember that the physical size and shape of a component may affect its performance in the instrument, particularly at high frequencies. All replacement parts should be direct replacements unless it is known that a different component will not adversely affect instrument performance.

Special Parts. In addition to the standard electronic components, some special components are used in the 432. These components are manufactured or selected by Tektronix, Inc. to meet specific performance requirements, or are manufactured for Tektronix, Inc. in accordance with our specifications. These special components are indicated in the Electrical Parts List by an asterisk preceding the part number. Most of the mechanical parts used in this instrument have been manufactured by Tektronix, Inc. Order all special parts directly from your local Tektronix Field Office or representative.

Ordering Parts. When ordering replacement parts from Tektronix, Inc., include the following information:

1. Instrument type.
2. Instrument serial number.
3. A description of the part (if electrical, include circuit number).
4. Tektronix Part Number.

Soldering Techniques

WARNING

Disconnect the instrument from the power source before soldering.

Circuit Boards. Use ordinary 60/40 solder and a 35- to 40-watt pencil type soldering iron on the circuit boards. The tip of the iron should be clean and properly tinned for best heat transfer to the solder joint. A higher wattage soldering iron may separate the wiring from the base material.

The following technique should be used to replace a component on a circuit board. Most components can be replaced without removing the boards from the instrument.

CAUTION

The Vertical Mode Switch, the Attenuator, and the Vertical Input Amplifier circuit boards are made of material easily damaged by excessive heat. When soldering to these boards, do not use a soldering iron with a rating of more than approximately 15 watts. Avoid prolonged applications of heat to circuit-board connections.

1. Grip the component lead with long-nose pliers. Touch the soldering iron to the lead at the solder connection. Do not lay the iron directly on the board as it may damage the board.

2. When the solder begins to melt, pull the lead out gently. This should leave a clean hole in the board. If not, the hole can be cleaned by reheating the solder and placing a sharp object such as a toothpick into the hole to clean it out. A vacuum-type desoldering tool can also be used for this purpose.

3. Bend the leads of the new component to fit the holes in the board. If the component is replaced while the board is mounted in the instrument, cut the leads so they will just protrude through the board. Insert the leads into the holes in the board so the component is firmly seated against the board (or as positioned originally). If it does not seat properly, heat the solder and gently press the component into place.

4. Touch the iron to the connection and apply a small amount of solder to make a firm solder joint; do not apply too much solder. To protect heat-sensitive components, hold the lead between the component body and the solder joint with a pair of long-nose pliers or other heat sink.

5. Clip the excess lead that protrudes through the board (if not clipped in step 3).

6. Clean the area around the solder connection with a flux-remover. Use only water-soluble detergents, ethyl, methyl, or isopropyl alcohol. Do not apply any solvent containing ketones, esters, or halogenated hydrocarbons. Be careful not to remove information printed on the board.

Metal Terminals. When soldering metal terminals, ordinary 60/40 solder can be used. Use a soldering iron with a 40- to 75-watt rating and a 1/8-inch wide wedge-shaped tip.

Observe the following precautions when soldering metal terminals:

1. Apply only enough heat to make the solder flow freely. Use a heat sink to protect heat-sensitive components.

2. Apply only enough solder to form a solid connection. Excess solder may impair the function of the part.

3. If a wire extends beyond the solder joint, clip off the excess.

4. Clean the flux from the solder joint with a flux-remover solvent.

Component Replacement

WARNING

Disconnect the instrument from the power source before replacing components.

Circuit Board Replacement. If a circuit board is damaged beyond repair, either the entire assembly including all soldered-on components, or the board only, can be replaced. Part numbers are given in the Mechanical Parts List for either the completely wired or the unwired board. Most of the components mounted on the circuit boards can be replaced without removing the boards from the instrument. Observe the soldering precautions given under Soldering Techniques in this section.

Most of the connections to the circuit boards in the instrument are made with pin connectors. However, some connections are soldered to the board. Use the following procedure to remove a circuit board:

1. Disconnect all pin connectors from the board and unsolder any soldered connections.

2. Remove all screws holding the board to the chassis.

3. Lift the circuit board out of the instrument. Do not force or bend the board.

Maintenance—432

4. To replace the board, reverse the order of removal. Correct location of the pin connectors is shown in Figs. 8-1 through 8-22. Replace the pin connectors carefully so they mate correctly with the pins. If forced into place incorrectly positioned, the pin connectors may be damaged.

Transistor Replacement. Transistors should not be replaced unless actually defective. If removed from their sockets during routine maintenance, return them to their original sockets. Unnecessary replacement of transistors may affect the calibration of this instrument. When transistors are replaced, check the operation of that part of the instrument which may be affected.



POWER switch must be turned off before removing or replacing transistors.

Replacement transistors should be of the original type or a direct replacement. Fig. 4-3 shows the lead configuration of the transistors used in this instrument. Some plastic case transistors have lead configurations which do not agree with those shown here. If a transistor is replaced by a transistor made by a different manufacturer than the original, check the manufacturer's basing diagram for correct basing. All transistor sockets in this instrument are wired for the basing used for metal-case transistors. Transistors which have heat radiators or are mounted on the chassis use silicone grease to increase heat transfer. Replace the silicone grease when replacing these transistors.

Handle silicone grease with care. Avoid getting silicone grease in the eyes. Wash hands thoroughly after use.

Cathode-Ray Tube Replacement. Use care when handling a CRT. Protective clothing and safety glasses should be worn. Avoid striking it on any object which might cause it to crack or implode. When storing a CRT, place it face down on a smooth surface with a protective cover or soft mat under the faceplate to protect it from scratches.

The CRT shield should also be handled carefully. This shield protects the CRT display from distortion due to magnetic interference. If the shield is dropped or struck sharply, it may lose its shielding ability.

The following procedure outlines the removal and replacement of the cathode-ray tube:

A. REMOVAL:

1. Remove the wrap-around cabinet as described previously.
2. Remove the light filter.
3. Remove the cover plate from the rear casting.
4. Remove the socket from the base of the CRT.
5. Remove the Z Axis Circuit Board from the instrument.
6. Disconnect the deflection plate leads from the neck of the CRT. Be careful not to bend or excessively squeeze the pins.
7. Remove the two screws securing the rear of the CRT shield to the rear casting.
8. Remove the delay-line assembly from the CRT shield by removing the lone screw in the middle of the delay line.
9. Remove the two screws securing the CRT shield to the front casting.
10. Remove the CRT assembly from the instrument.
11. Loosen the CRT clamp at the rear of the CRT shield.
12. Hold one hand on the CRT faceplate and push forward on the CRT base with the other. As the CRT starts out of the shield, grasp it firmly. When the CRT is free of the clamp, slide the shield completely off the CRT.

B. REPLACEMENT

1. Loosen the four hex-head screws on the front part of the CRT shield.
2. Insert the CRT into the shield. Loosen the two securing screws inside the rear of the CRT shield. Be sure the faceplate of the CRT is flush or slightly recessed with the front opening of the CRT shield. Do not tighten the CRT clamp yet.

3. Place the light mask over the CRT faceplate and reinsert the CRT assembly into the instrument. Be sure the CRT faceplate seats properly in the front casting. The lip on the upper edge of the front of the CRT shield must engage the slot in the front casting.

4. Replace the two screws securing the rear of the CRT shield to the rear casting.

5. Seat the CRT firmly against the front casting making sure the light mask is positioned correctly. Correctly align the CRT in the opening in the front casting by positioning and tightening the four hex-head screws loosened previously in step 1. Also tighten the three screws inside the rear of the CRT shield. Recommended tightening torque for the clamp screw is 4 to 7 inch/lbs.

6. Install the CRT socket on the base of the CRT.

7. Install the Z Axis Circuit Board.

8. Reconnect the deflection plate leads on the neck of the CRT. Be careful not to bend or excessively squeeze the pins.

9. Re-install the delay-line assembly on the bottom of the CRT shield.

10. Re-install the cover plate on the rear casting.

11. Re-install the CRT light filter in the front casting.

12. Recheck instrument calibration.

Fuse Replacement. The only fuse used in the instrument is the power-line fuse. Use only a 1 1/2 ampere fast-blow fuse as a replacement.

Power Transformer Replacement. If the power transformer becomes defective, contact your local Tektronix Field Office or representative for a warranty replacement (see warranty note in the front of this manual). Be sure to replace only with a direct replacement Tektronix transformer. After the transformer is replaced check the performance of the complete instrument.

The components located in the power-supply compartment can be reached for maintenance by using the following procedure:

1. Remove the wrap-around cabinet from the instrument as described earlier in this section.

2. Lay the instrument down flat with the power-supply compartment edge facing you.

3. Remove the two screws securing the compartment shield to the rear casting.

4. Loosen the two screws securing the compartment shield to the forward power-supply compartment bulkhead and slide the shield out of the instrument.

WARNING

Line AC, high voltage, and stored DC are present in this compartment. It is recommended the instrument not be operated with this shield removed.

After gaining access to the power-supply compartment, the power transformer assembly can be removed as follows:

1. Remove the Power Supply Secondary circuit board.

2. Remove the plastic insulating sheet that mounts beneath the Power Supply Secondary circuit board.

3. Remove the metal cover to the enclosure containing the power-supply transformer assembly.

4. Remove the transformer assembly from the enclosure. Be careful not to bend the pins.

Recalibration After Repair

After any electrical component has been replaced, the calibration of that particular circuit should be checked, as well as the calibration of other closely related circuits. Since the power supply affects all circuits, calibration of the entire instrument should be checked if work has been done in the power supply or if the transformer has been replaced.

Instrument Repackaging

If the 432 is to be shipped for long distances by commercial means of transportation, it is recommended that the instrument be repackaged in the original manner for maximum protection. The original shipping carton can be saved and used for this purpose. The Repackaging illustration in the Mechanical Parts Illustrations shows how to repackage the 432 and gives the part numbers for the repackaging components. New shipping cartons can be obtained from Tektronix, Inc. Contact your local Tektronix Field Office or representative.

SECTION 5 CALIBRATION

Change information, if any, affecting this section will be found at the rear of the manual.

Introduction

To assure instrument accuracy, check the calibration of the 432 every 1000 hours of operation, or every six months if used infrequently. Before complete calibration, thoroughly clean and inspect this instrument as outlined in the Maintenance section.

Tektronix Field Service

Tektronix, Inc. provides complete instrument repair and recalibration at local Field Service Centers and the Factory Service Center. Contact your local Tektronix Field Office or representative for further information.

Using This Procedure

To aid in locating a step in the Calibration procedure, an index is given prior to the complete procedure. Completion of each step in the full Calibration procedure insures that this instrument meets the electrical specifications given in Section 1. Where possible, instrument performance is checked before an adjustment is made. For best overall instrument performance when performing a complete calibration procedure, make each adjustment to the exact setting even if the CHECK— is within the allowable tolerance.

A partial calibration is often desirable after replacing components, or to touch up the adjustment of a portion of the instrument between major recalibration. To adjust only part of the instrument, set the controls as given under Preliminary Control Settings and start with the nearest Equipment Required List preceding the desired portion. To prevent unnecessary recalibration of other parts of the instrument, readjust only if the tolerance given in the CHECK— part of the step is not met. If re-adjustment is necessary, also check the calibration of any steps listed in the INTERACTION— part of the step.

IMPORTANT NOTE

All waveforms shown in this procedure were taken with a Tektronix Oscilloscope Camera System, unless otherwise noted. Limits, tolerances, and waveforms in this procedure are given as calibration guides and should not be interpreted as instrument specifications except as specified in Section 1.

TEST EQUIPMENT REQUIRED

General

The following test equipment and accessories, or their equivalent, are required for complete calibration of the

432. Specifications given for the test equipment are the minimum necessary for accurate calibration. Therefore, the specifications of any test equipment used must meet or exceed the listed specifications. All test equipment is assumed to be correctly calibrated and operating within the listed specifications. Detailed operating instructions for the test equipment are not given in this procedure. Refer to the instruction manual for the test equipment if more information is needed.

WARNING

Although it is not necessary for normal calibration of this instrument, the use of a 1:1 ratio isolation transformer rated at at least 100 watts and 600 volts primary to secondary insulation is recommended to protect personnel and associated equipment in case of accidental contact with various portions of the instrument which are at power line potential.

Special Calibration Fixtures

Special Tektronix calibration fixtures are used in this procedure only where they facilitate instrument calibration. These special calibration fixtures are available from Tektronix, Inc. Order by part number through your local Tektronix Field Office or representative.

Calibration Equipment Alternatives

All of the listed test equipment is required to completely calibrate this instrument. The Calibration procedure is based on the first item of equipment given as an example of applicable equipment. When other equipment is substituted, control settings or calibration setup may need to be altered slightly to meet the requirements of the substitute equipment. If the exact item of test equipment given as an example in the Test Equipment list is not available, first check the Specifications column carefully to see if any other equipment is available which might suffice. Then check the Usage column to see what this item of the test equipment is used for. If used for a check or adjustment which is of little or no importance to your measurement requirements, the item and corresponding step(s) can be deleted.

The following procedure is written to completely check and adjust the 432 to the Performance Requirements given in Section 1. If the applications for which you will use the 432 do not require the full available performance from the

Calibration—432

432, this procedure and the required equipment list can be shortened accordingly. For example, only the basic measurement capabilities of this instrument can be verified by checking vertical deflection accuracy with a Standard

Amplitude Calibrator, vertical square-wave response with fast-rise Square-Wave Generator (such as the Tektronix Type 106), and the horizontal timing using a Time-Mark Generator.

TEST EQUIPMENT

Description	Minimum Specifications	Usage	Example
1. Autotransformer with AC voltmeter	Capable of supplying 66 volt-Amperes at an output voltage of 120 VAC.	Power Supply adjustment.	General Radio W10MT3W Variac Autotransformer.
2. Test-oscilloscope system.	Bandwidth, DC to 25 megahertz; minimum deflection factor, five millivolts/division; accuracy, within 3%.	Adjust Power Supply operation, CRT grid bias, Sweep Generator offset adjustment, and Z-Axis Compensation.	a. Tektronix 7503 or 7504 Oscilloscope with 7A15 or 7A16 Amplifier and 7B50 or 7B52 Time-Base plug-in units, and P6053 Probe. b. Tektronix 432 Oscilloscope with a P6011 Probe and a P6061 Probe.
3. Precision DC voltmeter	Range, zero to 500 volts; accuracy, within 0.2%.	Calibrator output accuracy check and adjustment. Power Supply adjustment.	a. Tektronix 7D13 Digital Multimeter (test oscilloscope must have Readout System). b. Fluke Model 825A Differential DC Voltmeter.
4. DC voltmeter	Range, zero to 4000 volts; accuracy, checked to within 1% at -3940 volts.	High voltage power supply adjustment.	a. Triplet Model 630-NA. b. Simpson Model 262.
5. Time-mark generator	Marker outputs, 20 nanoseconds to 5 seconds; marker accuracy, within 0.1%.	CRT geometry check and adjustment. Horizontal timing check and adjustment. Calibrator repetition rate check and adjustment.	a. Tektronix 2901 Time-Mark Generator. b. Tektronix 184 Time-Mark Generator.
6. Medium-Frequency constant-amplitude signal generator	Frequency, 350 kilohertz to 25 megahertz; reference frequency, 50 kilohertz; output amplitude, variable from five millivolts to five volts peak to peak into 50 ohms; amplitude accuracy, constant within 3% of reference as output frequency changes.	External Z-axis operation check. Vertical amplifier bandwidth check. Trigger circuit check and adjustment.	a. Tektronix 191 Constant Amplitude Signal Generator. b. General Radio 1211-C with 1263-C Amplitude Regulating Power Supply.
7. Low-frequency signal generator	Frequency, 100 hertz to 30 kilohertz; output amplitude, variable from 35 millivolts to 40 volts.	Trigger circuit check and adjustment.	a. General Radio 1310-B Oscillator.
8. Standard Amplitude Calibrator	Amplitude accuracy, 0.25%; signal amplitude, 5 millivolts to 50 volts; output signal, one-kilohertz square wave.	Vertical amplifier gain check and adjustment. External and horizontal gain check.	a. Tektronix calibration fixture Part Number 067-0502-01.

TEST EQUIPMENT (cont)

Description	Minimum Specifications	Usage	Example
9. Square-wave generator	Frequency, one kilohertz and 100 kilohertz; risetime, one nanosecond or less from fast-rise output.	Vertical amplifier compensation checks and adjustments.	a. Tektronix Type 106 Square-Wave Generator.
10. Current Probe	Maximum Current, 5 A RMS.	Power Supply checks and adjustments. Not necessary for periodic recalibration.	a. Tektronix P6021 AC Current Probe with 011-0105-00 Passive Termination.
11. Adapter	Connectors, GR874 and BNC female.	Vertical amplifier bandwidth checks. Trigger circuit checks and adjustments.	a. Tektronix Part Number 017-0063-00.
12. Input normalizer	RC time constant, 24 picofarads times one megohm.	Standardize input RC time constant.	a. Tektronix Part Number 067-0539-00.
13. T connector	Connectors, BNC.	External trigger operation checks. External Z Axis operation check. ADD mode operation check.	a. Tektronix Part Number 103-0030-00.
14. Attenuator (two required)	Attenuation ratio, 10X; connectors BNC, impedance, 50 ohms.	Vertical amplifier compensation checks and adjustments.	a. Tektronix Part Number 011-0059-01.
15. Termination (two required)	Impedance, 50 ohms; accuracy, $\pm 2\%$; connectors, BNC.	External Z Axis operation check. Vertical amplifier bandwidth check. Trigger circuit operation checks and adjustments.	a. Tektronix Part Number 011-0049-01.
16. Cable (two required)	Impedance, 50 ohms; type, RG-58/U; length, 42 inches; connectors, BNC.	Used throughout procedure for signal interconnection.	a. Tektronix Part Number 012-0057-01.
17. Screwdriver	Three-inch shaft, 3/32-inch bit.	Used throughout procedure to adjust variable resistors.	a. Xcelite R-3323.
18. Low-capacitance screwdriver	1 1/2-inch shaft.	Used throughout procedure to adjust variable capacitors.	a. Tektronix Part Number 003-0000-00.
19. Tuning tool	Fits 5/64-inch (ID) hex cores.	Vertical amplifier high-frequency compensation adjustments.	a. Tektronix Part Number 003-0307-00 (handle) and 003-0310-00 (insert).
20. Isolation Transformer	Ratio 1:1 600 volts primary to secondary insulation (Safety grounds connected)	Power Supply troubleshooting to protect personnel and equipment. For primary power supply calibration. Suggested, but not required if extreme caution is used when power supply shields are removed.	

INDEX TO CALIBRATION PROCEDURE

Power Supply and Display Adjustment			
1. Preset Power Supply Current Sense Adjustment	Page 5-6	24. Adjust CH 1 and COMP Trigger DC Level	Page 5-18
2. Adjust -15-Volt Power Supply	Page 5-7	25. Check Trigger Circuit Operation	Page 5-19
3. Adjust Power Supply Current Sense Adjustment	Page 5-7	26. Check Single Sweep Operation	Page 5-19
4. Adjust High-Voltage Power Supply	Page 5-8	27. Check TRIGGER LEVEL Control Range	Page 5-20
5. Adjust CRT Grid Bias	Page 5-8	28. Check Line Triggering	Page 5-20
6. Adjust Focus Range and Astigmatism	Page 5-9	Horizontal System Adjustment	
7. Adjust Trace Rotation	Page 5-9	29. Adjust Sweep Generator Offset Adjustment	Page 5-21
8. Adjust Geometry	Page 5-9	30. Adjust Sweep Cal Adjustment	Page 5-22
9. Check BEAM FINDER Operation	Page 5-9	31. Adjust Horizontal Gain	Page 5-22
10. Check External Z Axis Operation	Page 5-9	32. Adjust Magnifier Registration	Page 5-22
11. Check Chopped Operation	Page 5-10	33. Check Variable TIME/DIV Range	Page 5-22
Vertical System Adjustment		34. Adjust High Speed Timing	Page 5-22
12. Adjust Channel 1 Balance	Page 5-11	35. Check TIME/DIV Accuracy	Page 5-23
13. Adjust Channel 2 Balance	Page 5-11	36. Check Magnified Sweep Accuracy	Page 5-23
14. Adjust CH 1 and CH 2 GAIN	Page 5-12	37. Check High Speed Magnified Timing Accuracy	Page 5-23
15. Check CH 1 Variable VOLTS/DIV Range and Attenuator Accuracy	Page 5-12	38. Check External Horizontal Sensitivity	Page 5-23
16. Check CH 2 Variable VOLTS/DIV Range and Attenuator Accuracy	Page 5-13	Calibrator Circuit Adjustment	
17. Check ADD Mode Operation	Page 5-13	39. Adjust Calibrator Output Voltage Amplitude	Page 5-24
18. Adjust Channel 1 VOLTS/DIV Switch Compensation	Page 5-13	40. Adjust Calibrator Repetition Rate	Page 5-24
19. Adjust Channel 2 VOLTS/DIV Switch Compensation	Page 5-14	Preliminary Procedure for Complete Calibration	
20. Adjust High Frequency Compensation	Page 5-14	<i>NOTE</i>	
21. Check Vertical Amplifier Bandwidth	Page 5-16	<i>This instrument should be adjusted at an ambient temperature of +25°C (±5°C) for best overall accuracy.</i>	
22. Check 5 MHz BW Bandwidth	Page 5-17	1. Remove the wrap-around cabinet from the 432 in the manner given in section 4 of this manual.	
Trigger Circuit Adjustment		2. Connect the autotransformer to a suitable power source.	
23. Adjust Trigger Level Centering	Page 5-18		

NOTE

If a line voltage source of exactly 120 VAC RMS is available, it will not be necessary to use the autotransformer.

3. Connect the 432 to the autotransformer output.

4. Set the autotransformer output voltage for exactly 120 VAC RMS.

5. Set the controls as given under Preliminary Control Settings. Allow at least 30 minutes warmup before proceeding.

NOTE

Titles for external controls of this instrument are capitalized in this procedure (e.g., INTENSITY). Internal adjustments are initial capitalized only (e.g., Sweep Cal).

Preliminary Control Settings

Preset the instrument controls to the settings given below when starting a Calibration procedure.

POWER/INTENSITY	Pulled out and rotated fully counterclockwise
POSITION (vertical and horizontal)	Midrange
5 MHz BW	Pushed in
INVERT	Pushed in
Input Coupling	AC
Vertical Mode	CH 1
VOLTS/DIV	.1 V
Variable VOLTS/DIV	CAL
TRIGGER SOURCE	COMP
TRIGGER COUPLING	AC
TRIGGER LEVEL	Midrange
TRIGGER SLOPE	+
Sweep MODE	SINGLE SWEEP
TIME/DIV	1 ms
VAR TIME/DIV	CAL

NOTES

POWER SUPPLY AND DISPLAY

Equipment Required

- | | | | |
|----------------------------------|--------------------|--------|--|
| 1. Test Oscilloscope | | | 7. Current Probe |
| 2. Medium-Frequency
Generator | Constant-Amplitude | Signal | 8. Adapter (GR874 and BNC female connectors) |
| 3. Time-Mark Generator | | | 9. 50 Ω BNC Termination |
| 4. Precision DC Voltmeter | | | 10. 42-Inch 50 Ω BNC Cables (2 ea.) |
| 5. DC Voltmeter | | | 11. BNC T Connector |
| 6. Autotransformer | | | 12. 3-Inch Screwdriver |

Control Settings

Preset instrument controls to the settings given under Preliminary Control Settings.

1. Preset Power Supply Current Sense Adjustment

NOTE

This step need be performed only if the setting of R1074 has become grossly misadjusted, or if major circuit components in the power supply have been replaced that would cause the setting of R1074 to be incorrect. If the power supply portion of this instrument has been working correctly, proceed with step 2.

a. Turn off instrument power, disconnect the power line, and remove the power supply compartment shields to provide access to leads connected to transistor Q1080. See Fig. 5-1.

WARNING

Under certain conditions, C1016 can remain charged for several minutes. If one of the two neon bulbs on the Primary Power Supply circuit board is still lit with instrument power turned off, wait until both lights are extinguished before attempting to discharge C1016 and/or working in the power supply area.

b. Connect the P6021 Current Probe around the collector lead (grey-yellow wire to pin 2 of P102 on Power Supply Primary circuit board) of Q1080 with the arrow on the head of the Current Probe pointing to the collector of Q1080.

c. Connect the Passive Termination for the Current Probe to the input connector of the test oscilloscope and connect the Current Probe to the Passive Termination.

d. Reconnect the line cord and turn on instrument power to the 432 under test.

WARNING

Line AC, high voltage, and stored DC are present in the Power Supply compartment. Primary Power Supply circuit common and guard box are elevated to line voltage potential. Do not touch the guard box or connect test equipment ground leads to the circuit common without first connecting the 432 under test to the power line through a 1:1 ratio isolation transformer that is insulated for 600 volts or more between primary and secondary. Exercise extreme caution when working in this area with the compartment shields removed.

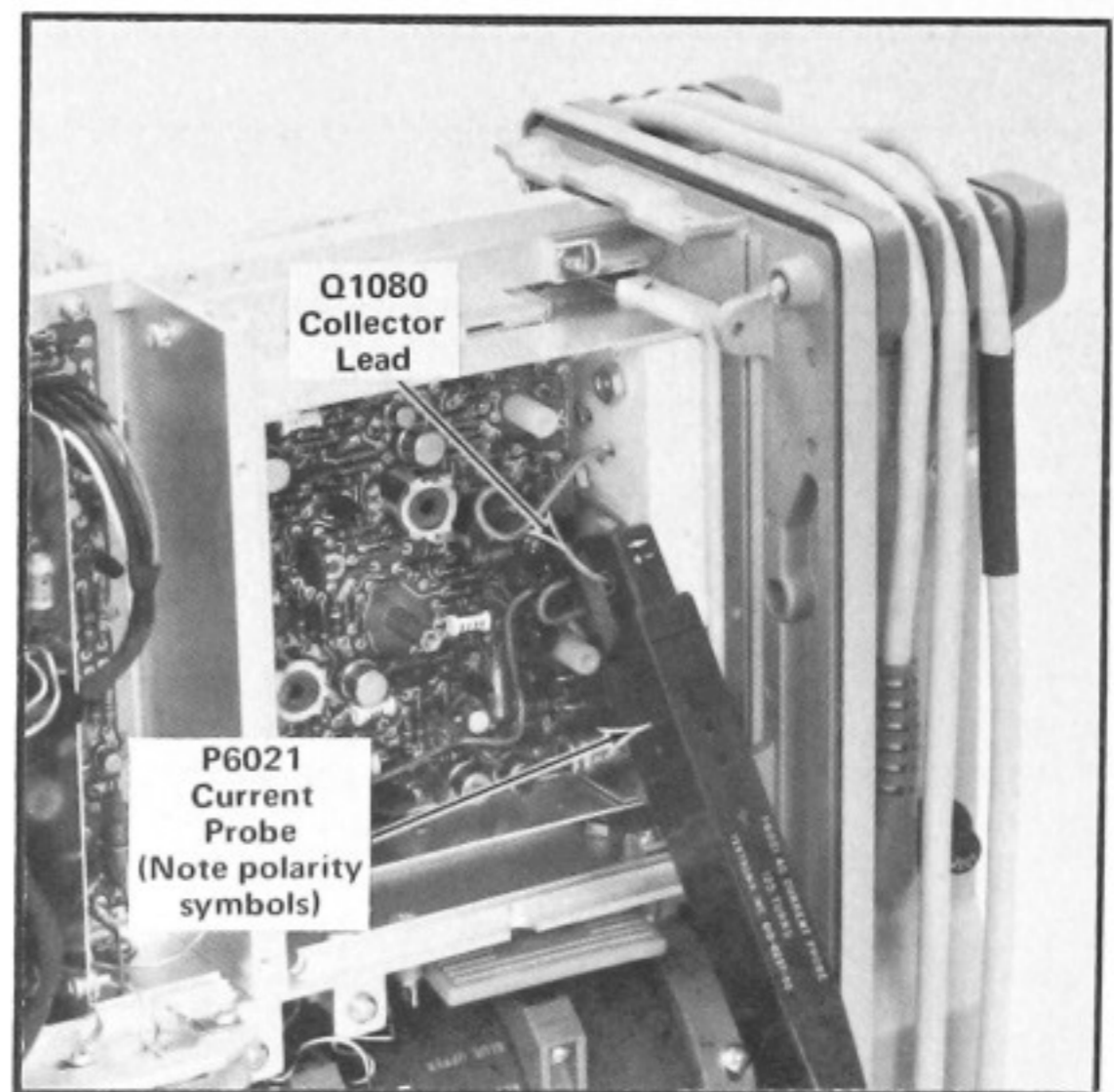

Fig. 5-1. Measuring Q1080 collector current.

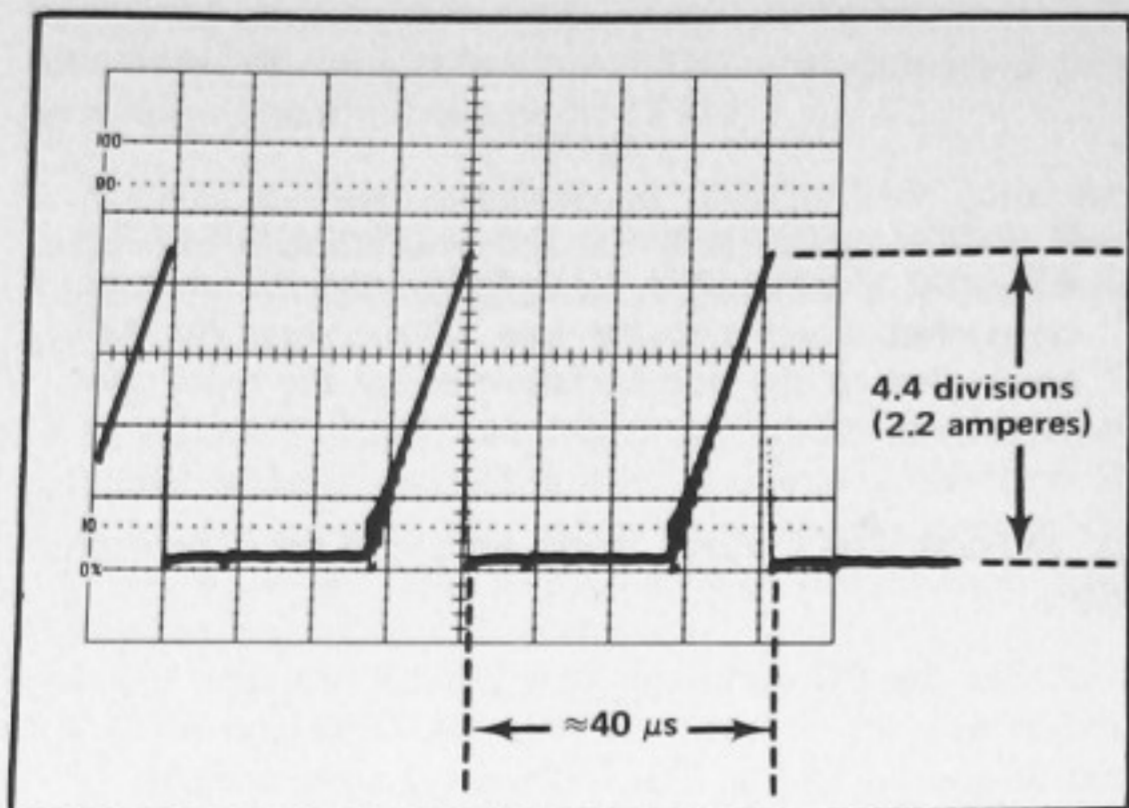

Fig. 5-2. Current waveform in collector circuit of Q1080.

e. Set the sensitivity of the Current Probe Passive Termination to 10 mA/mV and the Volts/Div switch of the test oscilloscope to 50 mV/div.

f. CHECK—Test oscilloscope display of 4.8 divisions peak to peak (peak current measurement of 2.4 amperes). See Fig. 5-2. Repetition rate should be approximately 25 kilohertz (40 μ s period).

g. ADJUST—Current Sense adjustment R1074 (see Fig. 5-3) for peak to peak display amplitude of 4.4 divisions, ± 0.2 division (2.2 amperes, ± 0.1 ampere).

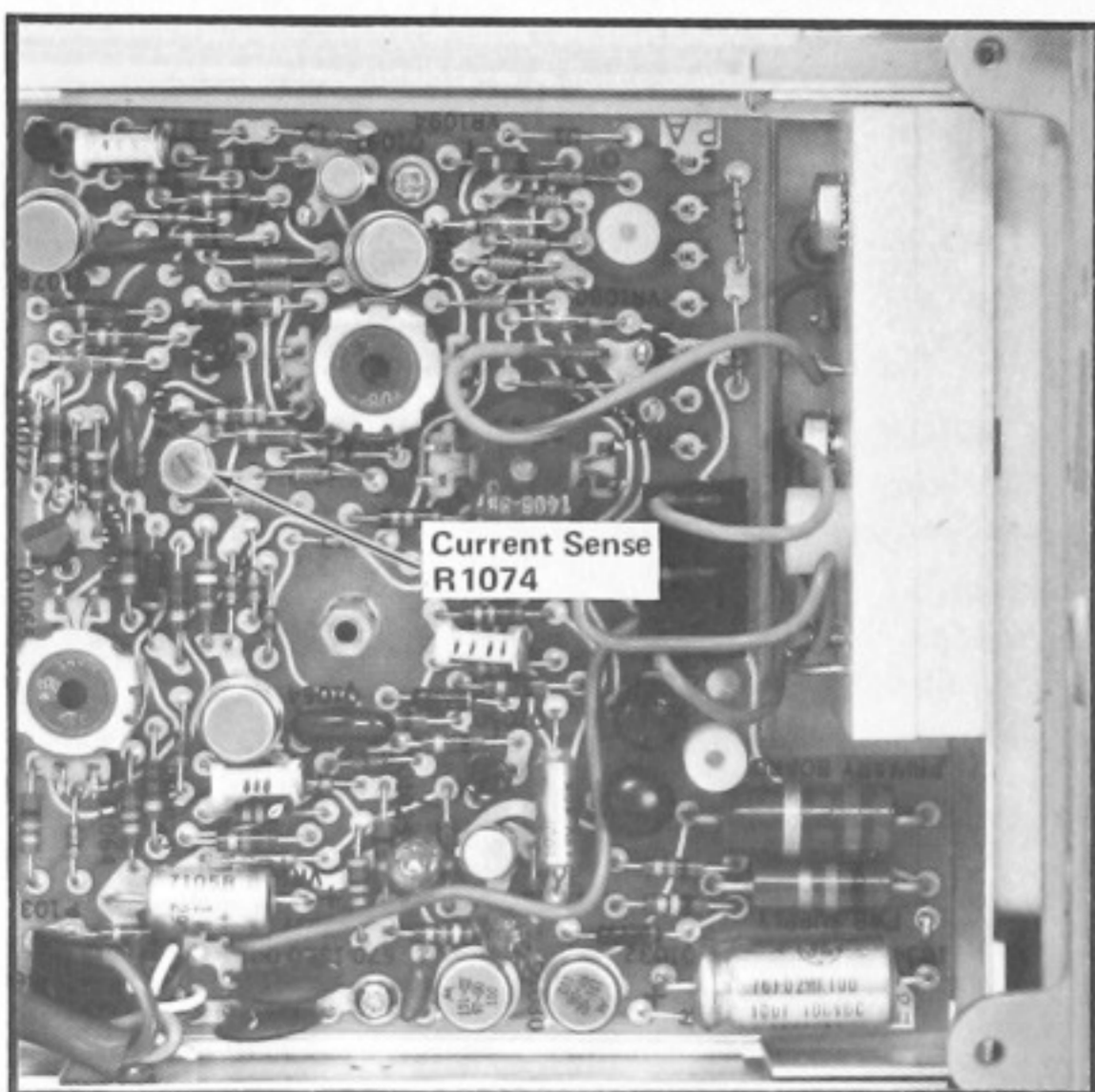

Fig. 5-3. Location of Current Sense adjustment R1074.

2. Adjust -15-Volt Power Supply

a. Connect the Precision DC Voltmeter between the -15-volt power supply test point (negative lead of C1107 on Power Supply Secondary circuit board (see Fig. 5-4) and ground.

b. CHECK—Meter reading of -15 volts, ± 0.112 volt (± 0.187 volt if the measurement is being made outside of the $+20^{\circ}\text{C}$ to $+30^{\circ}\text{C}$ temperature range).

c. ADJUST— -15 Volts adjustment R1122 (see Fig. 5-4) for a meter reading of -15 volts, ± 0.037 volt.

d. Disconnect the Precision DC Voltmeter from the 432 under test.

e. INTERACTION—May affect the operation of all circuits within the 432.

3. Adjust Power Supply Current Sense Adjustment

a. Obtain a display of the current waveform in the collector circuit of Q1080 in the manner given in Calibration Procedure step 1. (Note WARNING in steps 1a and 1d.)

NOTE

If step 1 was not performed, the need for the Current Probe can be eliminated by monitoring the repetition rate of the Power Supply Primary circuit using a test oscilloscope with a voltage probe connected to pin 1 of plug P127 on the Z Axis circuit board.

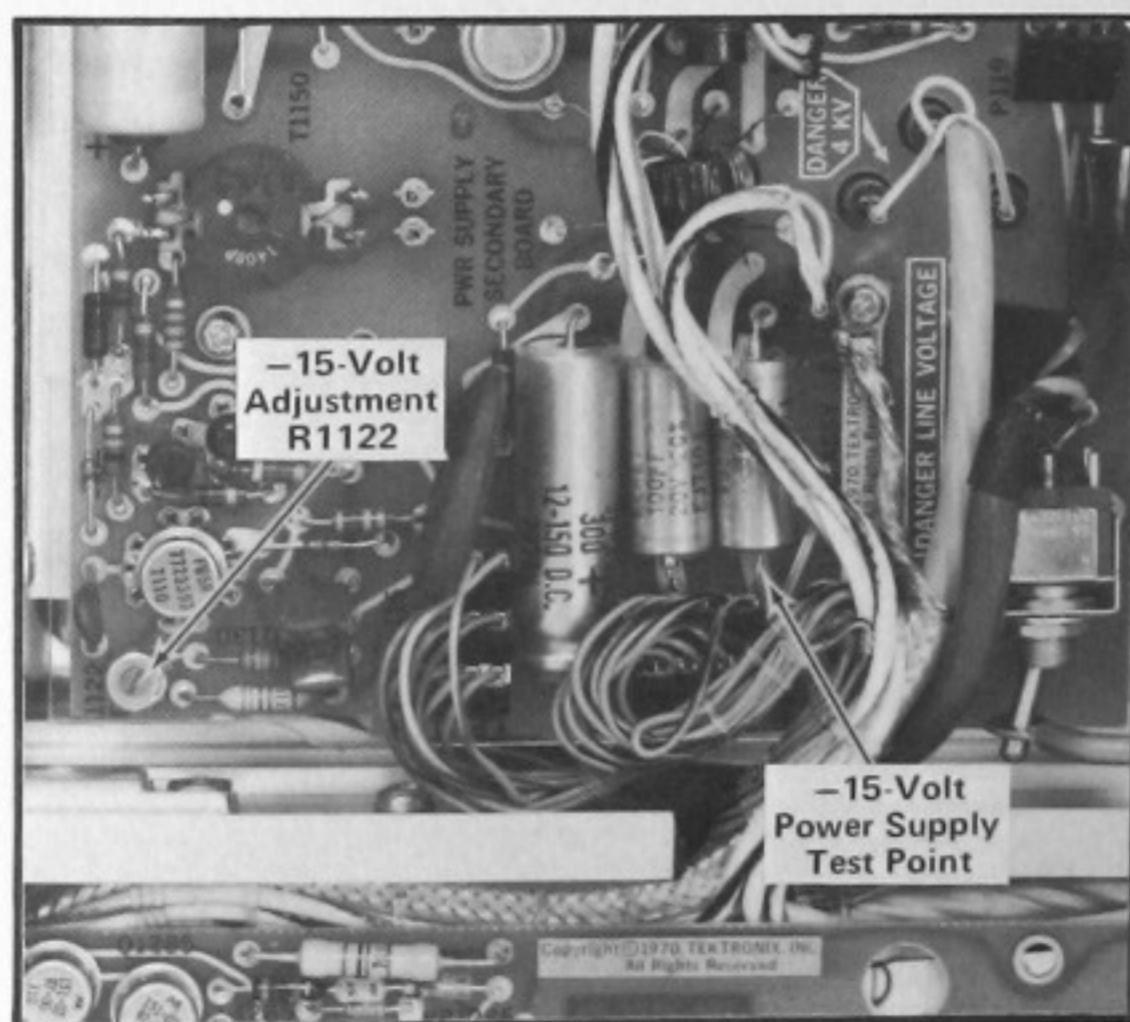

Fig. 5-4. Location of -15-Volt Power Supply Test Point.

Calibration—432

b. CHECK—Test oscilloscope display for 40 microsecond time period between current peaks.

c. ADJUST—Current Sense adjustment R1074 (see Fig. 5-3) for 40 microseconds, \pm one microsecond time period between current peaks.

d. Disconnect all test equipment and reinstall the Power Supply compartment shields.

e. INTERACTION—May affect the operation of all circuits within the 432.

4. Adjust High-Voltage Power Supply

a. Connect the DC Voltmeter between the -3940 volt test point TP962 (see Fig. 5-5) and ground (connect ground lead first).

b. CHECK—Meter reading of -3940 volts, ± 98.5 volts (± 118.2 volts if the measurement is being made outside of the $+20^{\circ}\text{C}$ to $+30^{\circ}\text{C}$ temperature range).

c. ADJUST—High Voltage Adjust R963 (see Fig. 5-5) for a meter reading of -3940 volts, ± 78.8 volts.

d. Disconnect the DC Voltmeter from the 432 under test.

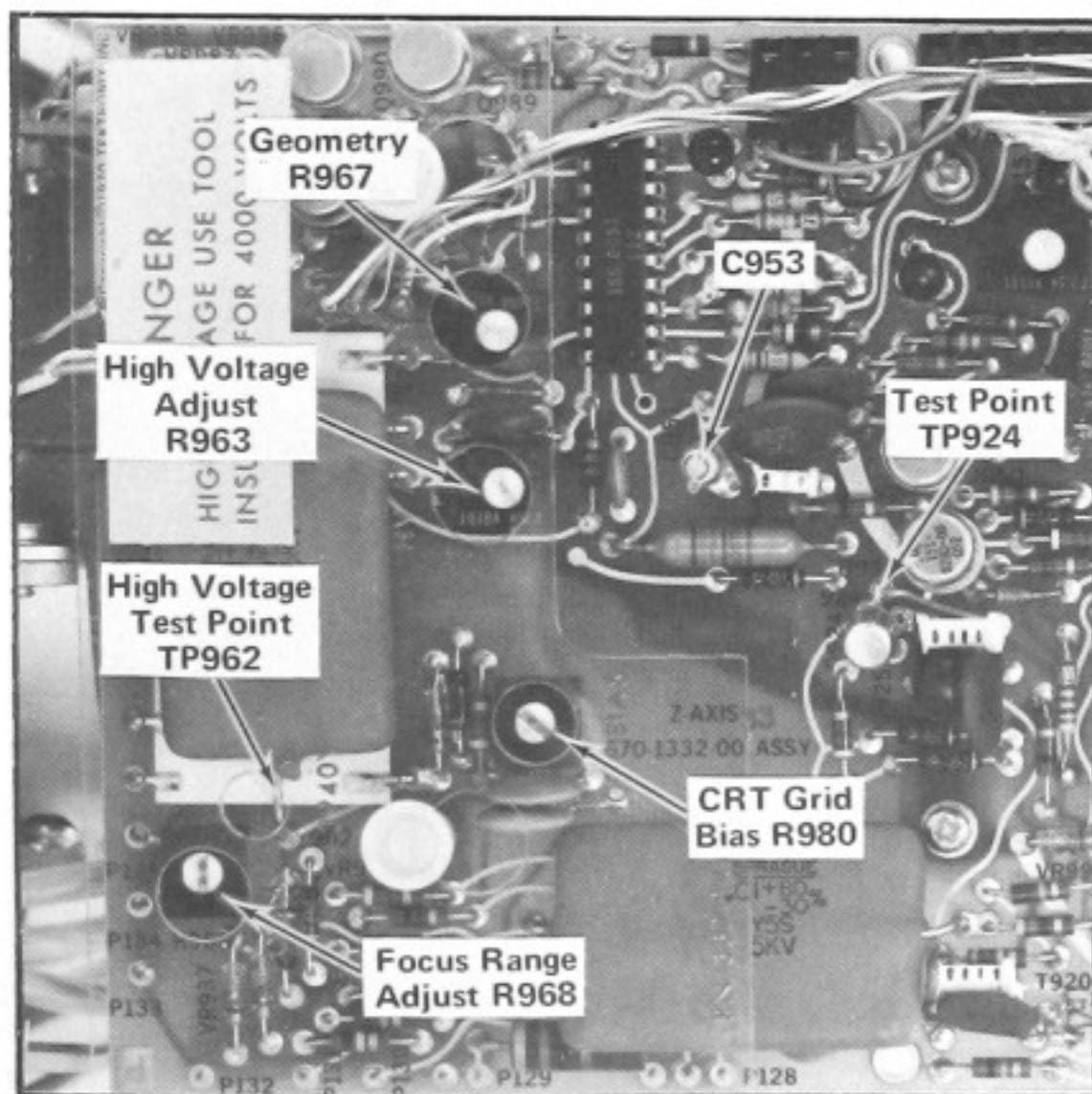

Fig. 5-5. CRT circuit test point and adjustment locations.

e. INTERACTION—May affect vertical gain, horizontal timing accuracy and CRT focus, astigmatism and geometry.

NOTE

If the line voltage is within the operating limits of the 432, (90 VAC to 264 VAC RMS), the 432 can be connected directly to the line, if not, leave the 432 connected to the autotransformer for the remainder of this procedure.

5. Adjust CRT Grid Bias and Z-Axis Compensation

a. Set the DC voltmeter to a 25 volt or higher DC range and attach the + lead to test point TP924 on the Z Axis circuit board (see Fig. 5-5) and the – lead to ground.

b. With the INTENSITY control fully counterclockwise, select the AUTO sweep mode and set the TIME/DIV switch to EXT HORIZ.

c. Turn the INTENSITY control clockwise until the CRT spot is visible (Horizontal and Vertical POSITION controls at mid-range) and position the spot near the center of the screen, but not on a graticule line.

CAUTION

To avoid possible damage to the CRT phosphor, do not allow a bright spot to remain stationary for an extended period of time.

d. ADJUST—The INTENSITY control for a voltmeter reading of +25 volts. If this increases spot brightness, reduce intensity by adjusting R980 (CRT Grid Bias adjustment) before adjusting the INTENSITY control for full 25 volts.

WARNING

A 4000 volt potential exists at R968 and R980. Use an adjustment tool with adequate insulation for this voltage.

e. Adjust R980 for a dim spot, then adjust R968 (Focus Range adjustment) and ASTIG (R85 on rear panel) for smallest round spot.

f. ADJUST—CRT Grid Bias adjustment R980 (see Fig. 5-5) so the spot on the CRT just disappears.

g. Disconnect the DC voltmeter and connect the tip of a 10X probe from the test oscilloscope to TP924.

h. Set the TIME/DIV switch to $0.2 \mu\text{s}$ and increase the INTENSITY control setting to obtain a visible display of nominal intensity.

i. With the test oscilloscope set to $0.2 \mu\text{s}/\text{DIV}$ and $5 \text{ V}/\text{DIV}$ (including the 10X probe attenuation), adjust its

triggering controls to trigger on the rising portion of the waveform, to obtain a stable display of the unblanking waveform present at test point TP924.

j. CHECK—Test oscilloscope display for optimum waveform risetime and flat top (aberrations 10% or less). Check for uniform brightness of the first division of the trace on the screen of the oscilloscope being calibrated.

k. ADJUST—C953 (see Fig. 5-5) for optimum waveform risetime without exceeding 10% aberrations. Perform the fine adjustment of C953, (while observing the first division of the trace on the screen of the oscilloscope being calibrated) for uniform brightness.

NOTE

If C953 is adjusted all the way in without reaching optimum adjustment, increase the range of C953 by increasing C952 from 1 pF (nominal value) to 1.8 pF. If further range is required, C952 can be replaced with a piece of wire. If C953 is adjusted all the way out without reaching the optimum adjustment, decrease the range of C953 by reducing C952 to 1.8 pF or to 1 pF.

l. Disconnect all test equipment. A final fine-adjustment of C953 for uniform brightness of the first division of signal may be desired after removing the test oscilloscope probe from TP924.

6. Adjust Focus Range and Astigmatism

a. Connect a 50 kHz signal from the Medium-Frequency constant amplitude sine-wave generator to the CH 1 input connector. Set the TIME/DIV switch to 5 or 10 μ s and adjust the signal generator amplitude for a vertical display of about 1.5 to 2 divisions.

b. Adjust the TRIGGER LEVEL control for a stable display and advance the INTENSITY control to a comfortable viewing level.

c. CHECK—CRT display for optimum focus of all portions of the display. The display should remain in focus as the setting of the INTENSITY control is varied.

d. ADJUST—Focus Range adjust R968 (see Fig. 5-5) and ASTIG adjust R85 (located on rear panel) for optimum focus of all portions of the display.

NOTE

The CRT focus circuit contains two selectable resistors, R83 and R964. If the CRT is replaced it may be necessary to change the values of these resistors. In Step 6.d., if the adjustment range of R968 does not allow optimum focus, the value of R964 (in parallel with R962C) should be changed. R83 is selected for optimum tracking of the focus voltage with changes in INTENSITY control setting. Optimum focus at high intensity should be checked

at a fast sweep speed but at a low sweep repetition rate, as this is the most common usage of high intensity levels. Good focus at high intensity is critical to good single-shot photography (or single-shot storage in a storage instrument) near the writing speed limit. Refer to the end of this section for information for selecting R83 and R964.

e. Disconnect signal from the input connectors.

7. Adjust Trace Rotation

a. Position the free-running trace to the center horizontal graticule line.

b. CHECK—The trace should be parallel with the center horizontal line.

c. ADJUST—TRACE ROTATION adjustment R80 (located on rear panel) so the trace is parallel with the horizontal graticule lines.

8. Adjust Geometry

a. Apply 1 ms and .1 ms time marks from the Time-Mark Generator to the CH 1 input connector.

b. Adjust the TRIGGER LEVEL control for a stable display with the TIME/DIV switch set to 1 ms.

c. Adjust the CH 1 POSITION control and the CH 1 VOLTS/DIV switch so the time marks extend above and below the vertical extremes of the CRT viewing area.

d. CHECK—CRT display for no more than 0.1 division of bowing or tilt of time marks.

e. ADJUST—Geometry adjustment R967 (see Fig. 5-5) for minimum bowing and tilt of time marks.

f. Disconnect the Time-Mark Generator.

9. Check BEAM FINDER Operation

a. Press the BEAM FINDER button.

b. Rotate the CH 1 POSITION and horizontal POSITION controls fully clockwise and then fully counterclockwise.

c. CHECK—Should not be able to position the free-running trace out of the graticule area when holding the BEAM FINDER button in.

10. Check External Z Axis Operation

a. Connect the output of the Medium-Frequency Constant-Amplitude Signal Generator to the EXT TRIG and Z AXIS input connectors via a 50 Ω termination, a BNC T, and two 42-inch 50 Ω BNC cables.

b. Adjust the Constant-Amplitude Signal Generator for a 5-volt output amplitude of 50 kilohertz reference signal.

Calibration—432

c. Set the TIME/DIV switch to 20 μ s and the TRIGGER SOURCE to EXT.

d. Adjust the TRIGGER LEVEL control for a stable display.

e. CHECK—CRT display for noticeable intensity modulation of the trace (may require reducing the setting of the INTENSITY control).

f. Increase the output frequency of the Constant Amplitude Signal Generator to 20 megahertz.

g. Set the TIME/DIV switch to .05 μ s.

h. CHECK—CRT display for noticeable intensity modulation of the trace.

i. Disconnect all test equipment.

b. Apply 1 μ s time marks to the CH 1 input connector.

c. Adjust the TRIGGER LEVEL control for a stable display.

d. Adjust the TIME/DIV switch and the Variable TIME/DIV control for exactly two markers per division.

e. Disconnect the Time-Mark Generator. Do not change the setting of the TIME/DIV switch or the Variable TIME/DIV control.

f. Set the Vertical Mode to CHOP.

g. Adjust the TRIGGER LEVEL control for a stable display.

h. Adjust the CH 1 and CH 2 POSITION controls to separate the two traces.

i. CHECK—Time duration of chopped waveform should be approximately 4.2 to 6.2 divisions (80 kilohertz to 120 kilohertz, approximately).

11. Check Chopped Operation

a. Set the TIME/DIV switch to 2 μ s and the TRIGGER SOURCE to COMP.

NOTES

VERTICAL SYSTEM ADJUSTMENT

Equipment Required

- | | |
|--|---|
| <ol style="list-style-type: none"> 1. Standard Amplitude Calibrator 2. Square-Wave Generator 3. Medium-Frequency Constant-Amplitude Signal Generator 4. 24 pF Input Normalizer 5. 42-Inch 50 Ω BNC Cable (2 required) 6. BNC 50 Ω 10X Attenuator | <ol style="list-style-type: none"> 7. Adapter (GR874 and BNC female connectors) 8. 50 Ω BNC Termination 9. BNC T Connector 10. 3-Inch Screwdriver 11. Low-Capacitance Screwdriver 12. Tuning Tool |
|--|---|

Control Settings

Preset the instrument controls to the settings given under Preliminary Control Settings except as follows:

Sweep MODE	AUTO
INTENSITY	For visible display
Input Coupling	GND
TRIGGER LEVEL	Fully clockwise

12. Adjust Channel 1 Balance

- a. Change the CH 1 VOLTS/DIV switch from 10 mV to 1 mV.
- b. CHECK—CRT display for not more than 0.1 division of trace shift when switching from 10 mV to 1 mV.
- c. ADJUST—CH 1 STEP ATTEN BAL adjustment (located on front panel) for minimum trace shift when switching from 10 mV to 1 mV.
- d. Set the CH 1 VOLTS/DIV switch to 10 mV.
- e. Rotate the CH 1 Variable VOLTS/DIV control.
- f. CHECK—CRT display for not more than 0.3 division of trace shift when rotating the CH 1 Variable VOLTS/DIV control.
- g. ADJUST—Variable Balance adjust R212 (see Fig. 5-6) for minimum trace shift when rotating the CH 1 Variable VOLTS/DIV control.
- h. Set the CH 1 VOLTS/DIV switch to 10 mV and the CH 1 Variable VOLTS/DIV control to CAL.

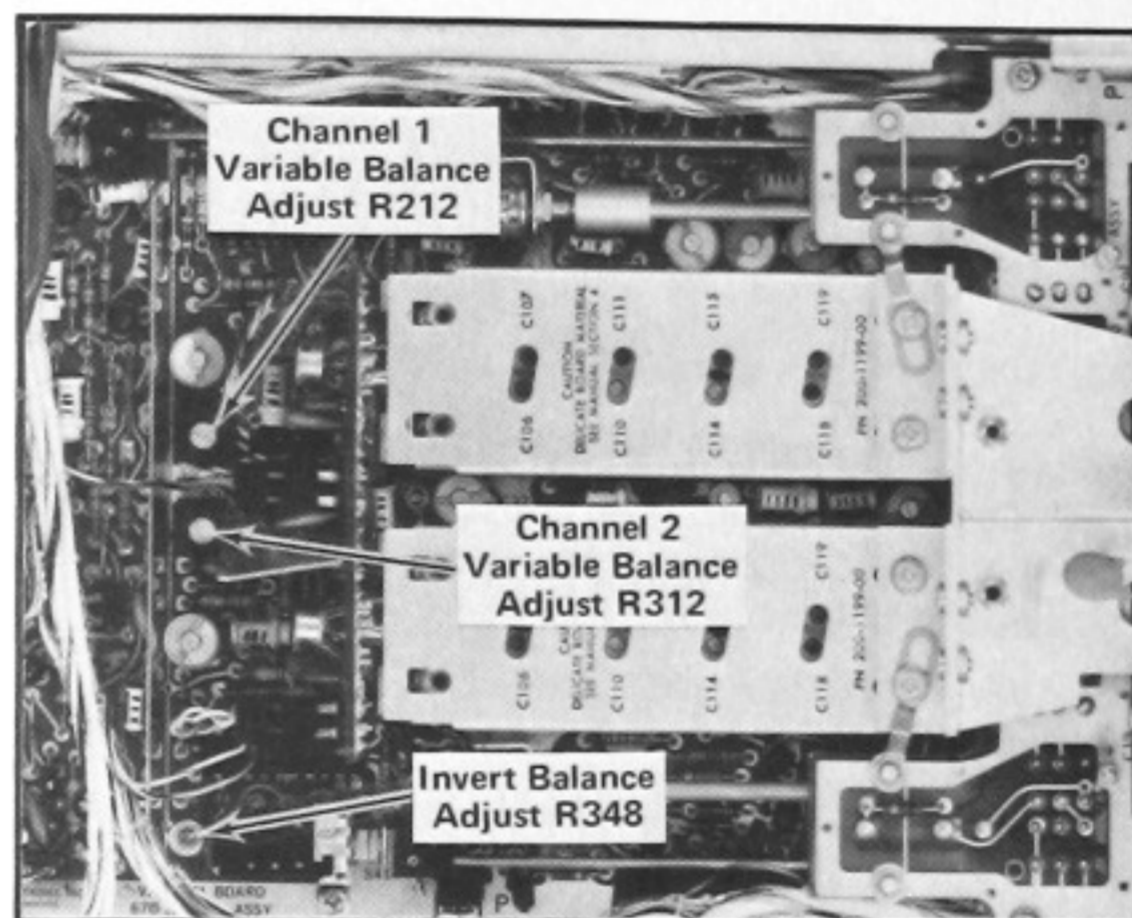

Fig. 5-6. Location of Channel 1 and 2 balance adjustments.

13. Adjust Channel 2 Balance

- a. Set the Vertical Mode to CH 2.
- b. Change the CH 2 VOLTS/DIV switch from 10 mV to 1 mV.
- c. CHECK—CRT display for not more than 0.1 division of trace shift when switching from 10 mV to 1 mV.
- d. ADJUST—CH 2 STEP ATTEN BAL adjustment (located on front panel) for minimum trace shift when switching from 10 mV to 1 mV.
- e. Set the CH 2 VOLTS/DIV switch to 10 mV.

Calibration—432

- f. Rotate the CH 2 Variable VOLTS/DIV control.
- g. CHECK—CRT display for not more than 0.3 division of trace shift when rotating the CH 2 Variable VOLTS/DIV control.
- h. ADJUST—Variable Balance adjust R312 (see Fig. 5-6) for minimum trace shift when rotating the CH 2 Variable VOLTS/DIV control.
- i. Set the CH 2 VOLTS/DIV switch to 10 mV and the CH 2 Variable VOLTS/DIV control to CAL.
- j. Position the free-running trace to the center horizontal graticule line.
- k. Set the INVERT switch to the INVERT position (button out).
- l. CHECK—CRT display for not more than 1.0 division of trace shift when inverting the Channel 2 display.
- m. ADJUST—Invert Balance adjustment R348 (see Fig. 5-6) for minimum trace shift when inverting the Channel 2 display.
- n. Push the INVERT button in.

14. Adjust CH 1 and CH 2 GAIN

- a. Set input coupling for both channels to DC.
- b. Connect the output of the Standard Amplitude Calibrator to the CH 2 input connector via a 42-inch BNC cable.
- c. Set the Standard Amplitude Calibrator for a 50 millivolt signal output amplitude.
- d. CHECK—CRT display for 5 divisions, ± 0.15 division of deflection.
- e. ADJUST—CH 2 GAIN adjustment (located on front panel) for exactly 5 divisions of deflection.
- f. Change Vertical Mode to CH 1.
- g. Remove the Standard Amplitude Calibrator signal from the CH 2 input connector and connect it to the CH 1 input connector.
- h. CHECK—CRT display for 5 divisions, ± 0.15 division of deflection.
- i. ADJUST—CH 1 GAIN adjustment (located on front panel) for exactly 5 divisions of deflection.

15. Check CH 1 Variable VOLTS/DIV Range and Attenuator Accuracy

- a. With exactly a 5-division amplitude display, rotate the CH 1 Variable VOLTS/DIV control.
- b. CHECK—CRT display can be reduced in amplitude to two divisions or less.
- c. Set the CH 1 Variable VOLTS/DIV control to CAL.

- d. CHECK—Using the CH 1 VOLTS/DIV switch and the Standard Amplitude Calibrator settings given in Table 5-1, check to see if the vertical deflection factor accuracy for each position of the CH 1 VOLTS/DIV switch is within 3%.

NOTE

Replacing U210 in Channel 1 or U310 in Channel 2 may affect gain accuracy at 1 and 2 mV/DIV. R220 (CH 1) and R320 (CH 2) are selectable for 1 mV/DIV gain accuracy. R223 (CH 1) and R323 (CH 2) are selectable for 2 mV/DIV gain accuracy. If the 1 mV/DIV or 2 mV/DIV ranges are outside of specified tolerances at the completion of step 14 Gain adjustments, an approximate 2% resistance change of R220, R320, R223, or R323 will result in a 2% gain change for the corresponding range and channel. If the display exceeds 5.15 divisions, increase the resistor value by 2%. If the display is less than 4.85 divisions, decrease the value of the appropriate resistor by 2%. If less than a 2% gain change is desired, alter the effective resistor value in 1% increments by paralleling the next higher optional resistor value desired with R219, R222, R319, or R322 as necessary.

Capacitors C222 and C322 affect the front corner response of the 1 mV range for channels 1 and 2 respectively, while capacitors C228 and C328 affect the front corner response of the 2 mV range. If correct compensation cannot be obtained with C220, C223, C320, and C323 adjustments, add or subtract from the value of C222, C322, C228, or C328 in approximately 15 pF increments until the desired compensation is obtained for the range and channel in question.

TABLE 5-1

Vertical Deflection Accuracy

VOLTS/DIV Switch Setting	Standard Amplitude Calibrator Output	Vertical Deflection in Divisions	Maximum Error For $\pm 3\%$ Accuracy
1 mV	5 millivolts	5	± 0.15 division
2 mV	10 millivolts	5	± 0.15 division
5 mV	20 millivolts	4	± 0.12 division
10 mV	50 millivolts	5	Previously set in step 14.
20 mV	0.1 volt	5	± 0.15 division
50 mV	0.2 volt	4	± 0.12 division
.1 V	0.5 volt	5	± 0.15 division
.2 V	1 volt	5	± 0.15 division
.5 V	2 volts	4	± 0.12 division
1 V	5 volts	5	± 0.15 division
2 V	10 volts	5	± 0.15 division
5 V	20 volts	4	± 0.12 division
10 V	50 volts	5	± 0.15 division

16. Check CH 2 Variable VOLTS/DIV Range and Attenuator Accuracy

- a. Remove the Standard Amplitude Calibrator signal from the CH 1 input connector and connect it to the CH 2 input connector and set the Vertical Mode to CH 2.
- b. With the CH 2 VOLTS/DIV switch set to 10 mV, set the Standard Amplitude Calibrator for a 50 millivolt output signal amplitude.
- c. With an exactly 5-division amplitude display, rotate the CH 2 Variable VOLTS/DIV control.
- d. CHECK—CRT display can be reduced in amplitude to two divisions or less.
- e. Set the CH 2 Variable VOLTS/DIV control to CAL.
- f. CHECK—Using the CH 2 VOLTS/DIV switch and the Standard Amplitude Calibrator settings given in Table 5-1, check to see if the vertical deflection factor accuracy for each position of the CH 2 VOLTS/DIV switch is within 3%.

c. Adjust the output of the Square-Wave Generator for a display five divisions in amplitude and a repetition rate of one kilohertz.

d. Adjust the TRIGGER LEVEL control for a stable display.

e. CHECK—CRT display at each Channel 1 VOLTS/DIV switch position for optimum square corner and flat top. Typically less than +2%, -2%, or a total of 2% peak to peak aberration within the +20°C to +30°C temperature range. Remove the 10X attenuator and the 50 Ω BNC termination as necessary to maintain a five-division display amplitude.

f. ADJUST—Channel 1 VOLTS/DIV switch compensation as given in Table 5-2. Adjust for optimum square corner and flat top. Remove the 10X attenuator and/or 50 Ω BNC termination as necessary to maintain a five-division display amplitude. Fig. 5-7 shows the location of the variable compensation adjustments.

17. Check ADD Mode Operation

- a. Apply the Standard Amplitude Calibrator output signal to both the CH 1 and CH 2 input connectors via a BNC T and two 42-inch 50 Ω BNC cables.
- b. Set both VOLTS/DIV switches to .1 V and the Vertical Mode to ADD.
- c. Set the Standard Amplitude Calibrator for a .2 volt output signal.
- d. CHECK—CRT display for 4 divisions, ±0.12 division of deflection.
- e. Disconnect all test equipment.

18. Adjust Channel 1 VOLTS/DIV Switch Compensation

- a. Set the Channel 1 VOLTS/DIV switch to 10 mV, the Vertical Mode to CH 1, the CH 1 Input Coupling to DC, and the Vertical Mode to CH 1.
- b. Connect the high-amplitude output of the Square-Wave Generator (Type 106) to the CH 1 input connector via a GR to BNC adapter, a 42-inch 50 Ω BNC cable, a 50 Ω BNC 10X attenuator, a 50 Ω BNC termination, and a 24 picofarad input normalizer.

TABLE 5-2

VOLTS/DIV Switch Compensation

VOLTS/DIV Switch Setting	Attenuator Compensated	Adjusted for optimum	
		Square Corner	Flat Top
10 mV	÷1		C9 for Channel 1 C19 for Channel 2
5 mV	Check	If error is greater than 2%, compromise setting at 1 mV, 2 mV, 5 mV, and 10 mV for best overall response.	
2 mV	Check		
1 mV	Check		
20 mV	÷2	C106	C107
50 mV	÷5	C110	C111
.2 V	÷10	C114	C115
Remove external 10X attenuator from generator			
.2 V	Check	If error is greater than 2%, compromise setting at .1 V, .2 V, and .5 V for best overall response.	
.5 V	Check		
Remove 50 Ω termination			
1 V	÷100	C118	C119
2 V	Check	If error is greater than 2%, compromise setting at 1 V, 2 V, 5 V, and 10 V for best overall response.	
5 V	Check		
10 V	Check		

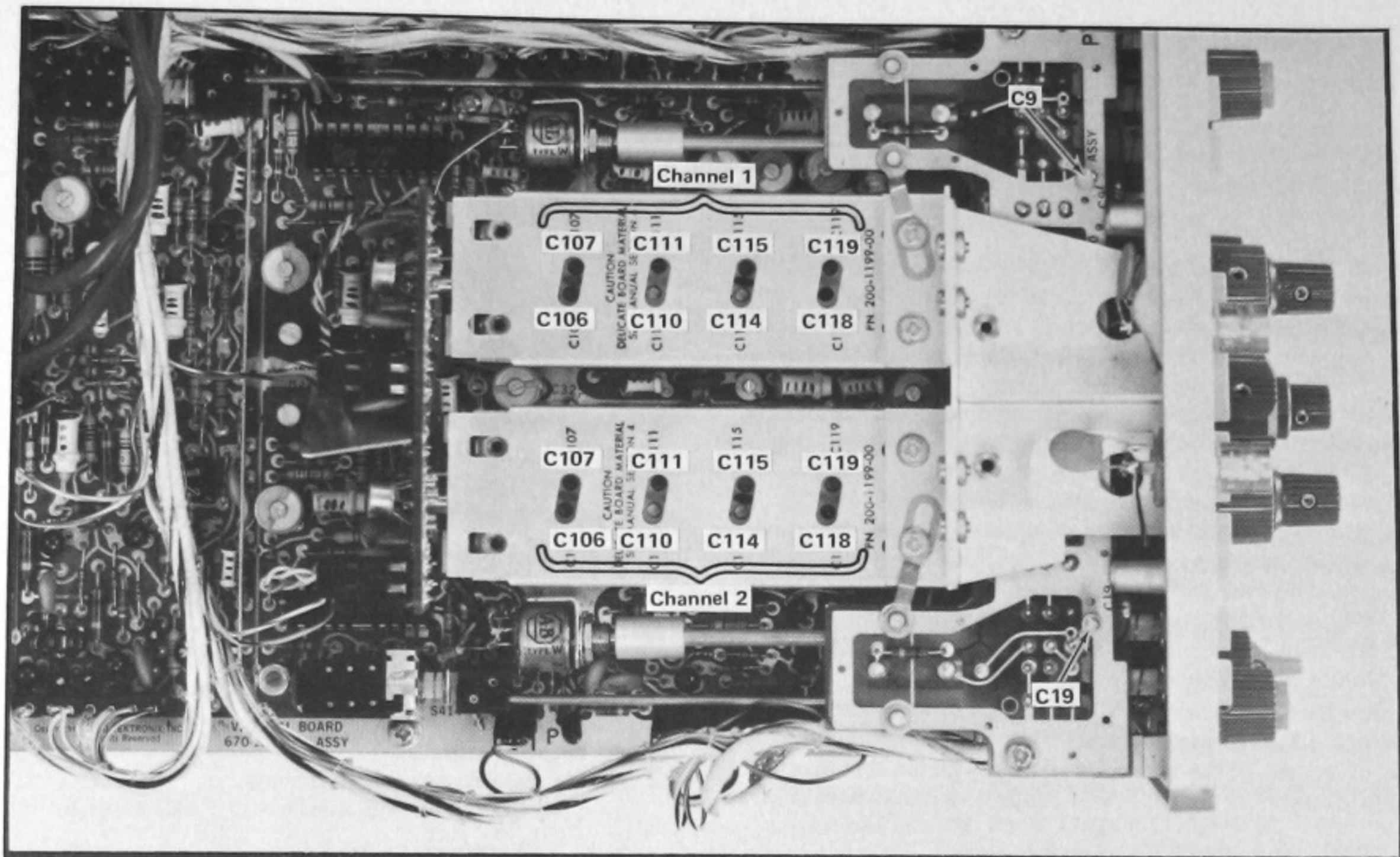

Fig. 5-7. Location of CH 1 & CH 2 VOLTS/DIV switch compensation adjustments.

19. Adjust Channel 2 VOLTS/DIV Switch Compensation

a. Set the Channel 2 VOLTS/DIV switch to 10 mV, the Vertical Mode to CH 2, and the CH 2 Input Coupling to DC.

b. Connect the high-amplitude output of the Square-Wave Generator (Type 106) to the CH 2 input connector via a GR to BNC adapter, a 42-inch 50 Ω BNC cable, a 50 Ω BNC 10X attenuator, a 50 Ω BNC termination, and a 24 picofarad input normalizer.

c. Adjust the output of the Square-Wave Generator for a display five divisions in amplitude and a repetition rate of one kilohertz.

d. CHECK—CRT display at each Channel 2 VOLTS/DIV switch position for optimum square corner and flat top. Typically less than +2%, -2%, total of 2% peak to peak aberration within the +20°C to +30°C temperature range. Remove the 10X attenuator and the 50 Ω BNC termination as necessary to maintain a five division display amplitude.

e. ADJUST—Channel 2 VOLTS/DIV switch compensation as given in Table 5-2. Adjust for optimum square

corner and flat top. Remove the 10X attenuator and 50 Ω BNC termination as necessary to maintain a five-division display amplitude. Fig. 5-7 shows the location of the variable compensation adjustments.

f. Disconnect all test equipment.

20. Adjust High Frequency Compensation

a. Connect the positive-going fast-rise output of the Square-Wave Generator (Type 106) to the CH 1 input connector via a GR to BNC adapter, a 42-inch 50 Ω BNC cable, and a 50 Ω BNC termination.

b. Set the Vertical Mode to CH 1 and both VOLTS/DIV switches to 10 mV.

c. Set the Square-Wave Generator for a six-division display with a repetition rate of 100 kHz. (If generator output cannot be reduced enough, add a 10X attenuator between the cable and the 50 Ω termination.) Switch the TIME/DIV to 5 μs and trigger the waveform in COMP on + SLOPE.

d. Adjust the TRIGGER LEVEL control for a stable display.

e. Vertically center the display in the CRT viewing area with the CH 1 POSITION control.

f. CHECK—CRT display for optimum risetime with aberrations typically less than +4%, -4%, a total of 4% peak to peak within the +20°C to +30°C temperature range. If risetime is out of specification or aberrations are greater than typical values; Preset R570 (Above SN B179999) and C226 to midrange, L533 core centered in form, and L584 core flush with top of form.

g. ADJUST—R461 and C461 for flat front portion of waveform top. Switch to 0.2 μs and adjust C572 for maximum overshoot. Adjust L533, C217, C226, R461, and C461 for a flat front corner of waveform top with some aberrations behind the front corner. Adjust L584 for minimum aberrations behind the front corner. Check waveform at various sweep speeds and slightly readjust R570, L533, R461, C461, and C217 as necessary for maximum risetime and minimum aberrations.

h. Position the top of the display to the bottom graticule line.

i. CHECK—CRT display for aberrations, typically less than +7%, -7%, or a total of 7% peak to peak. If aberrations exceed this amount, repeat steps 20e through i.

Position of R535, R586, the CRT leads from L533 and L584, the lead from Q530 to L533, and replacing or interchanging Q530 and Q580 all may affect aberrations with the trace at various positions on the CRT screen.

NOTE

The tolerances given in steps i, o, t, and w apply only in the temperature range of +20°C to +30°C. If the results of any portion of steps 20 and 21 are outside of suggested tolerances or typical values, repeat all of both steps for the best overall compromise of Risetime, Bandwidth, and aberrations. If major components have been replaced, it may be necessary to reselect the values of the various associated components marked as selected on the schematic diagram.

j. Remove the Square-Wave Generator signal from the CH 1 input connector and connect it to the CH 2 input connector.

k. Set Vertical Mode to CH 2 and vertically center the display with the CH 2 POSITION control.

l. CHECK—CRT display for optimum risetime with aberrations typically less than +4%, -4%, or a total of 4%

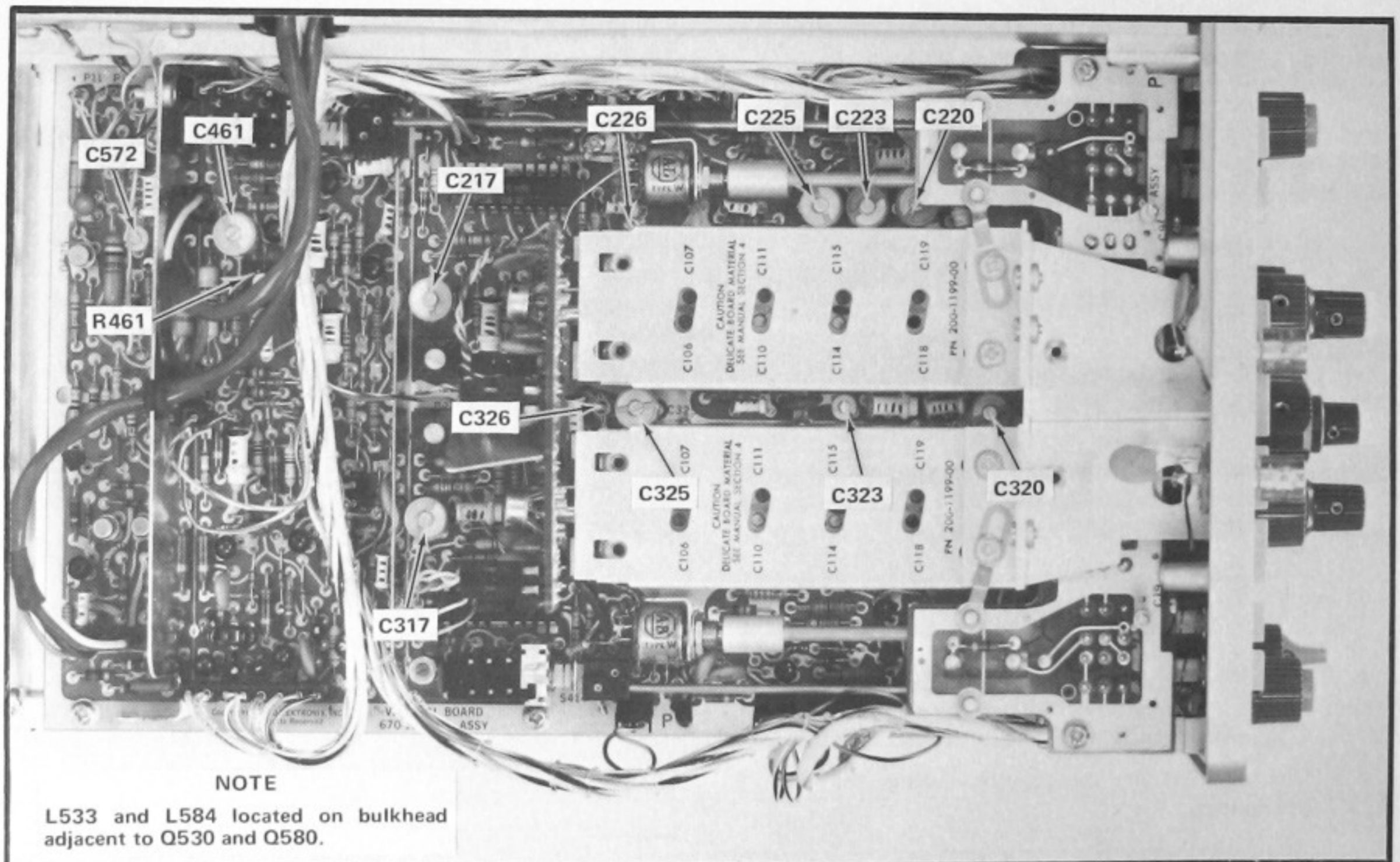

Fig. 5-8. Location of vertical system high-frequency compensation adjustments.

Calibration—432

peak to peak within the +20°C to +30°C temperature range.

m. ADJUST—C317 and C326 (see Fig. 5-8) for optimum risetime with aberrations typically less than +4%, -4%, or a total of 4% peak to peak within the +20°C to +30°C temperature range.

n. Position the top of the display to the bottom graticule line.

o. CHECK—CRT display for aberrations typically less than +7%, -7%, or a total of 7% peak to peak.

p. Connect the negative-going fast-rise output of the Square-Wave Generator to the CH 2 input connector.

q. Adjust the Square-Wave Generator for a six division display.

r. Set TRIGGER SLOPE to - and obtain a stable display.

s. Position the bottom of the display to the top of the graticule.

t. CHECK—CRT display for aberrations typically less than +9%, -9%, or a total of 9% peak to peak.

u. Remove the Square-Wave Generator signal from the CH 2 input connector and connect it to the CH 1 input connector.

v. Set Vertical Mode to CH 1 and position the bottom of the display to the top of the graticule.

w. CHECK—CRT display for aberrations typically less than +9%, -9%, or a total of 9% peak to peak.

x. Reconnect the positive-going fast-rise output from the Square-Wave Generator to the CH 1 input connector and set the TRIGGER SLOPE switch to +.

y. Set the CH 1 VOLTS/DIV switch to 5 mV.

z. Adjust the Square-Wave Generator for a six-division display.

aa. Vertically center the display using the CH 1 POSITION control.

ab. CHECK—CRT display in 1 mV, 2 mV, and 5 mV positions of the CH 1 and CH 2 VOLTS/DIV switches.

Refer to Table 5-3. Use the 10X BNC attenuator as necessary to maintain a six-division display amplitude.

TABLE 5-3
Amplifier Compensation

VOLTS/DIV Switch Setting	Compensation Adjustment	Typical Aberration
5 mV	C225 in Channel 1 C325 in Channel 2	Less than +4%, -4%, total of 4% peak to peak.
2 mV	C223 in Channel 1 C323 in Channel 2	
1 mV	C220 in Channel 1 C320 in Channel 2	Less than +4%, -4%, total of 4% peak to peak.

ac. ADJUST—Refer to Table 5-3 for the correct adjustment and tolerances. See Fig. 5-8 for adjustment locations.

ad. Disconnect all test equipment.

21. Check Vertical Amplifier Bandwidth

a. Connect the output of the Medium-Frequency Constant-Amplitude Signal Generator to the CH 1 input connector via a GR to BNC adapter, a 42-inch 50 Ω BNC cable, a 10X BNC attenuator, and a 50 Ω BNC termination.

b. Set both VOLTS/DIV switches to 10 mV, the Vertical Mode to CH 1, and the TRIGGER LEVEL control fully clockwise.

c. Adjust the signal generator output amplitude for a six-division display of the 50 kilohertz reference frequency.

d. Without changing the output amplitude, increase the output frequency until the display is reduced to 4.2 divisions.

e. CHECK—Output frequency of the signal generator must be at least 25 megahertz.

f. Repeat this bandwidth check procedure for all positions listed in Table 5-4. Check both Channel 1 and Channel 2.

TABLE 5-4
Vertical Amplifier Bandwidth

VOLTS/DIV Switch Setting	Minimum Bandwidth	
	-15°C to +30°C	+30°C to +55°C
10 mV	25 megahertz	25 megahertz
5 mV	23 megahertz	21 megahertz
2 mV	20 megahertz	18 megahertz
1 mV	18 megahertz	16 megahertz

TRIGGER CIRCUIT ADJUSTMENT

Equipment Required

- | | | | |
|--|---------------------------|---|--|
| 1. Medium-Frequency Generator | Constant-Amplitude Signal | 4. BNC T Connector | |
| 2. Low-Frequency Signal Generator | | 5. 42-Inch 50 Ω BNC Cable (two required) | |
| 3. 50 Ω BNC Termination (two required) | | 6. 3-Inch Screwdriver | |
| | | 7. 50 Ω BNC 10X Attenuator (two required) | |

Control Settings

Preset the instrument controls to the settings given under Preliminary Control Settings except as follows:

Sweep MODE	AUTO
TIME/DIV	50 μs
INTENSITY	Visible Display
TRIGGER COUPLING	AC

23. Adjust Trigger Level Centering

a. Connect the output of the Medium-Frequency Constant-Amplitude Signal Generator to the CH 1 input connector via a GR to BNC adapter, a 42-inch 50 Ω BNC cable, and a 50 Ω BNC termination.

b. Adjust the output of the signal generator for a 0.3-division display of the 50 kilohertz reference frequency.

c. Vertically center the display around the center graticule line.

d. CHECK—That the TRIGGER LEVEL control can be adjusted for a stable display with the TRIGGER LEVEL control knob pointing somewhere in the word “LEVEL” (check this for both + and – positions of the TRIGGER SLOPE switch).

e. ADJUST—Trigger Level Centering adjustment R629 (see Fig. 5-9) for a stable display in the + position of the TRIGGER SLOPE switch with the TRIGGER LEVEL control centered.

24. Adjust CH 1 and COMP Trigger DC Level

a. Set the TRIGGER COUPLING to DC and the TRIGGER SLOPE switch to +.

b. CHECK—CRT for a stable display.

c. ADJUST—Comp Trigger DC Level adjustment R274 (see Fig. 5-10) for a stable display.

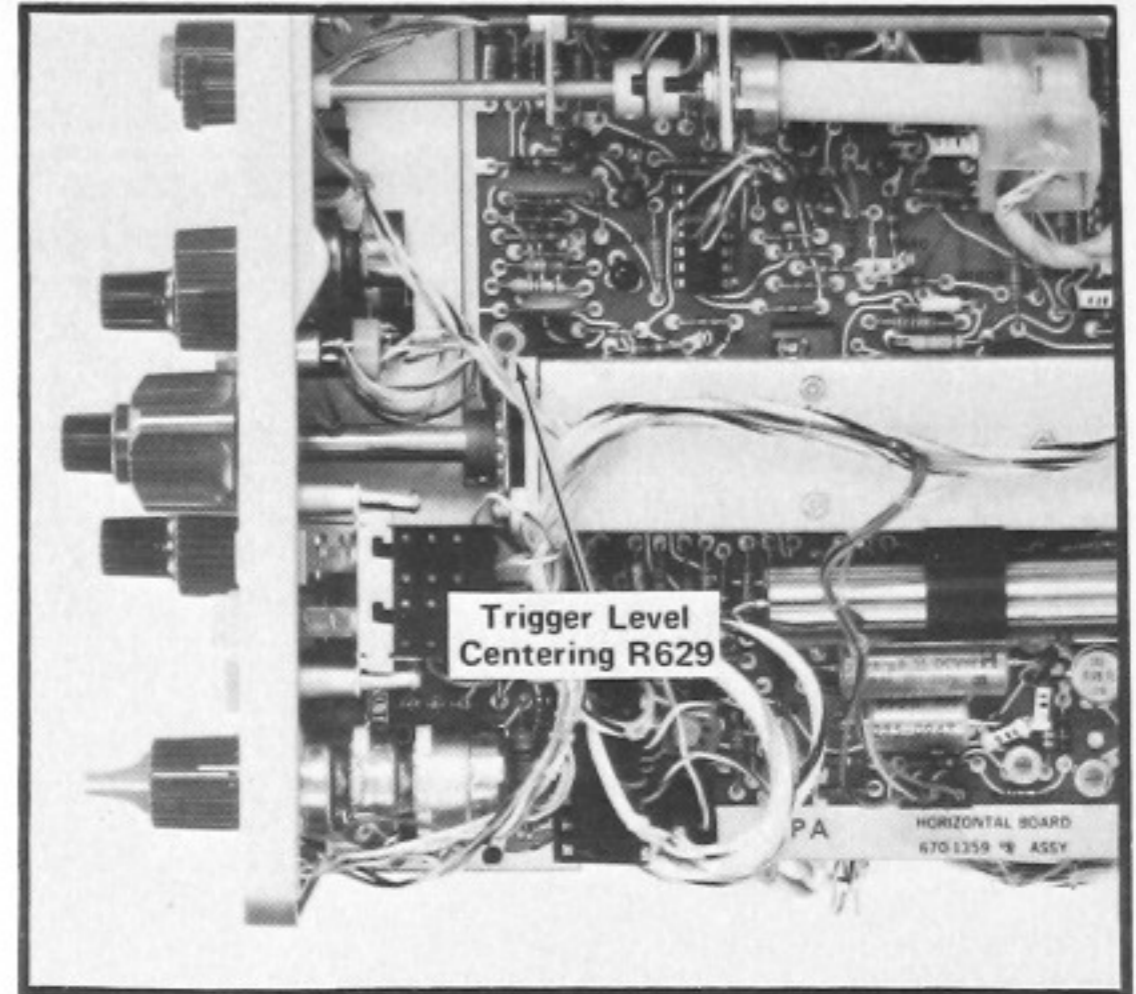

Fig. 5-9. Location of Trigger Level Centering adjustments.

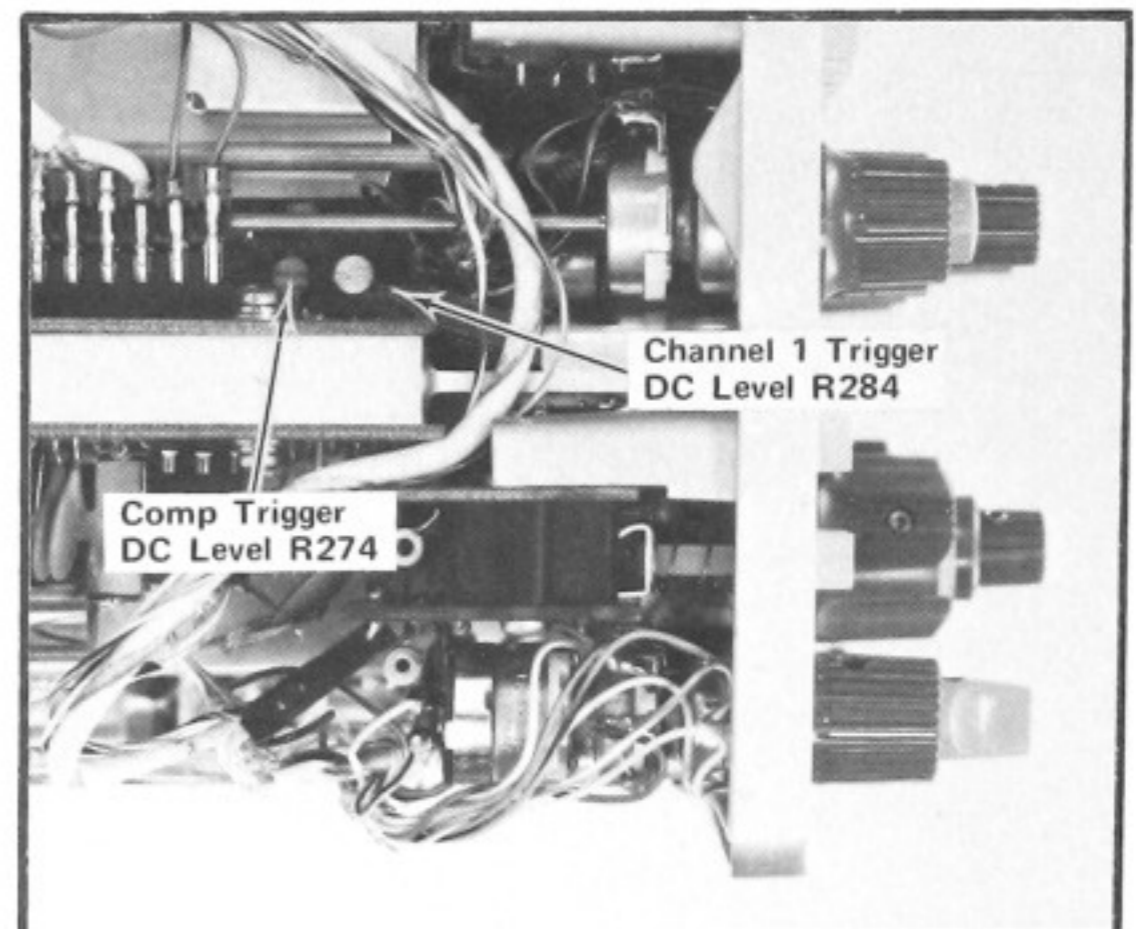

Fig. 5-10. Location of trigger DC level adjustments.

- d. Set the TRIGGER SOURCE to CH 1.
- e. CHECK—CRT for a stable display.
- f. ADJUST—CH 1 Trigger DC Level adjustment R284 (see Fig. 5-10) for a stable display.

25. Check Trigger Circuit Operation

NOTE

For EXT trigger checks: Adjust the signal amplitude at the 50 kHz reference frequency, then switch to the check point frequency without changing the amplitude control.

- a. Attach a T connector to a GR-BNC adapter and connect the GR end of the adapter to the Medium Frequency Constant Amplitude signal generator. To each output of the T connector, attach a 42 inch 50 Ω BNC cable, a 50 Ω BNC 10X attenuator and a 50 Ω BNC termination (in that order). Connect one of the terminations to the CH 1 input connector and the other termination to the EXT TRIG input connector on the rear panel.
- b. CHECK—Stable display can be obtained using the signal amplitude and coupling modes given in Table 5-5.

TABLE 5-5

Trigger Operation Check

TRIGGER SOURCE	TRIGGER COUPLING	Minimum Signal Amplitude	
		5 MHz	25 MHz
CH 1 & COMP	AC		
	DC	0.3 div	1 div
EXT	LF REJ		
	AC	50 mV	175 mV
	DC		
	LF REJ		

- c. Set TRIGGER SOURCE to COMP and TRIGGER COUPLING to HF REJ.
- d. Adjust the signal generator for a 0.7 division display of the 50 kilohertz reference frequency.
- e. CHECK—A stable display can be obtained.
- f. Adjust the signal generator output for a 0.7 division display of a 1 megahertz signal.

- g. CHECK—A stable display can not be obtained. Push HF REJ button to release.
- h. Replace the Medium-Frequency Constant-Amplitude Signal Generator with a Low-Frequency Signal Generator and remove the 50 Ω BNC termination from the test setup (42-inch 50 Ω BNC cable should be connected directly to the EXT TRIG input connector).

- i. Set the TRIGGER COUPLING to LF REJ.
- j. Adjust the Low-Frequency Signal Generator for a 0.7 division display of a 30 kilohertz signal.
- k. CHECK—A stable display can be obtained.
- l. Adjust the signal generator for a 0.7 division display of a 100 hertz signal.
- m. CHECK—A stable display can not be obtained. Push LF REJ button to release.
- n. Adjust the signal generator for a 0.7 division display of a 100 kilohertz signal.
- o. Set Sweep MODE to NORM.
- p. CHECK—Should be able to obtain a stable display. When the TRIGGER LEVEL control is rotated fully counterclockwise or clockwise, there should be no display presented on the CRT.

26. Check Single Sweep Operation

- a. Adjust the signal generator for a 0.3-division display of a 1 kilohertz signal.
- b. Set the TRIGGER COUPLING to AC.
- c. Adjust the TRIGGER LEVEL control for a stable display.
- d. Set the Sweep MODE to SINGLE SWEEP.
- e. Press the RESET button.
- f. CHECK—A single-sweep display (one sweep only) is presented.
- g. Rotate the TRIGGER LEVEL control fully clockwise.
- h. Press the RESET button.

Calibration—432

- i. CHECK—The READY light comes on and remains on until the sweep is triggered.
- j. Rotate the TRIGGER LEVEL control through mid-range.
- k. CHECK—A single-sweep display (one sweep only) is presented and the READY light goes out.

27. Check TRIGGER LEVEL Control Range

- a. Set the Sweep MODE to AUTO, TRIGGER COUPLING to DC, TRIGGER SOURCE to EXT, and the CH 1 VOLTS/DIV switch to 1 V.
- b. Adjust the signal generator for a 4-division display of a 1 kilohertz signal.
- c. CHECK—Rotate the TRIGGER LEVEL control throughout its range and check that the display can be triggered (stable display) at any point along the slope of the waveform in both the + and – positions of the TRIGGER SLOPE switch. This indicates a control range of at least +2 volts to –2 volts.
- d. Set the EXT ATTEN pushbutton to 1:10 and the CH 1 VOLTS/DIV switch to 10 V.
- e. Adjust the signal generator for a 4-division display of a 1 kilohertz signal.

- f. CHECK—Rotate the TRIGGER LEVEL control throughout its range and check that the display can be triggered (stable display) at any point along the slope of the waveform in both the + and – positions of the TRIGGER SLOPE switch. This indicates a control range of at least +20 volts to –20 volts.
- g. Disconnect all test equipment.

28. Check Line Triggering

- a. Connect a 10X probe (432 standard accessory) to the CH 1 input connector.
- b. Set the TRIGGER SOURCE to LINE, the TRIGGER COUPLING to AC, and the CH 1 VOLTS/DIV switch to 10 V.
- c. Connect the probe tip to the same line-voltage source which is connected to the instrument.
- d. Adjust the TRIGGER LEVEL control for a stable display.
- e. CHECK—Stable CRT display triggered on the correct slope in both the + and – positions of the TRIGGER SLOPE switch.
- f. Disconnect all test equipment.

NOTES

HORIZONTAL SYSTEM CALIBRATION

Equipment Required

- | | |
|----------------------------------|--------------------------------|
| 1. Test Oscilloscope | 4. 42-Inch 50 Ω BNC Cable |
| 2. Time-Mark Generator | 5. 3-Inch Screwdriver |
| 3. Standard Amplitude Calibrator | 6. Low-Capacitance Screwdriver |

Control Settings

Preset instrument controls to the settings given under Preliminary Control Settings except as follows:

Sweep MODE	AUTO
INTENSITY	Visible Display

29. Adjust Sweep Generator Offset

- a. Connect a 1X probe to the test oscilloscope vertical input.
- b. Connect the tip of the 1X probe to TP701 (see Fig. 5-11).

c. Set the test oscilloscope input coupling to ground and establish a 0 V DC reference level.

d. Set the test oscilloscope input coupling to DC and the Volts/Div to 5 mV.

e. CHECK—Test oscilloscope display is within two divisions of the 0 V DC reference level.

f. ADJUST—Sweep Generator Offset adjustment R703 (see Fig. 5-11) to center the test oscilloscope display around the 0 V DC reference level.

g. Disconnect all test equipment.

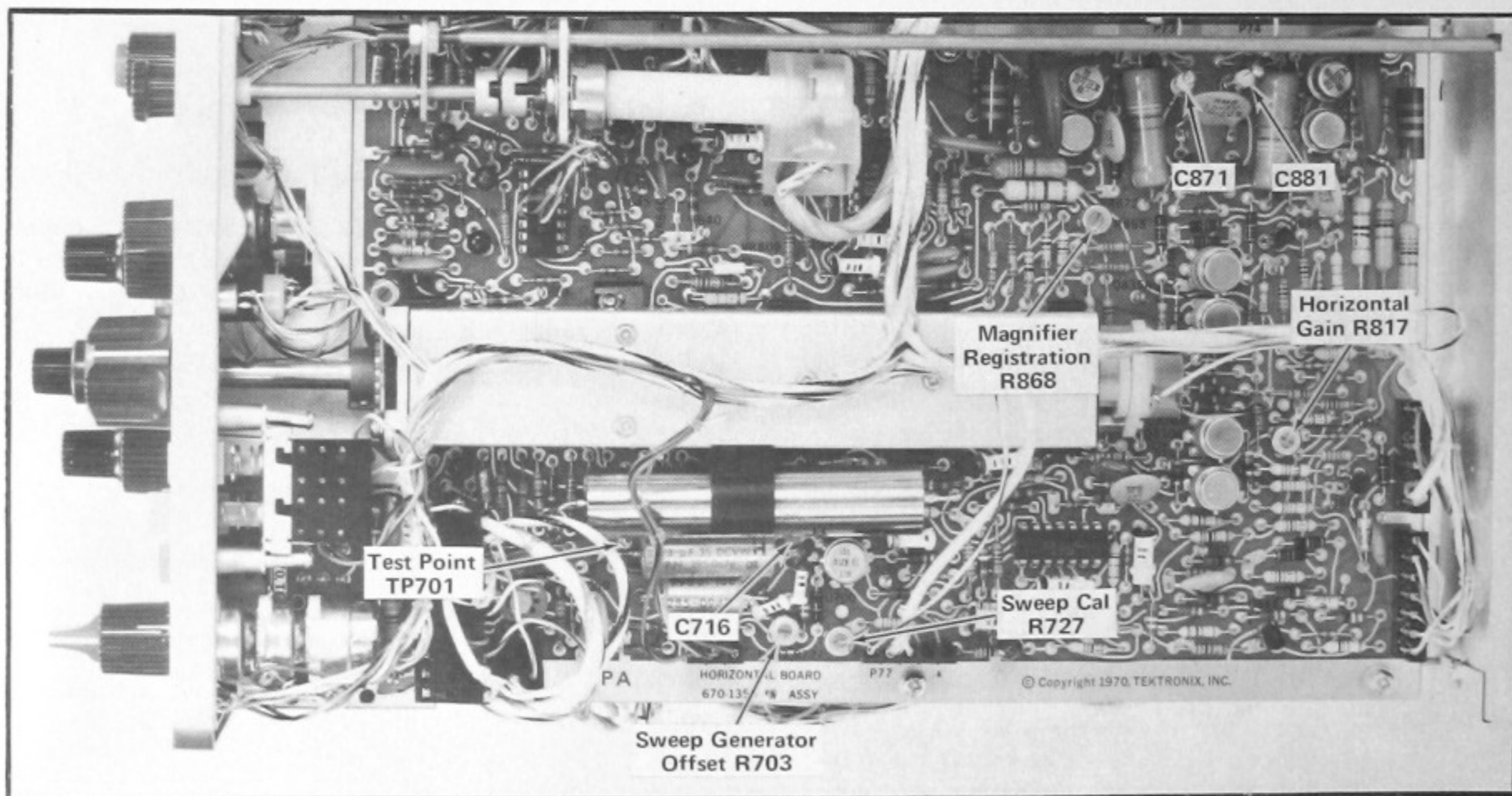

Fig. 5-11. Location of horizontal system adjustments and test points.

30. Adjust Sweep Cal Adjustment

- a. Connect a Time-Mark Generator to the CH 1 input connector via a 42-inch 50 Ω BNC cable.

NOTE

If the Tektronix Type 184 Time-Mark Generator is used, attach the signal to the CH 1 input connector via a 42-inch 50 Ω BNC cable and a 50 Ω BNC termination.

- b. Set the Sweep MODE to NORM.
- c. Set the Time-Mark Generator for 1 ms and .1 ms time marks.
- d. Set the CH 1 VOLTS/DIV switch to .5 V and adjust the TRIGGER LEVEL control for a stable display.
- e. CHECK—CRT display for a sweep duration of approximately 11 ms (indicated by 12 one millisecond time marks).
- f. ADJUST—Sweep Cal adjustment R727 (see Fig. 5-11) for a sweep duration of 11 milliseconds.

31. Adjust Horizontal Gain

- a. Horizontally position the display to align the first time mark with the left hand edge of the CRT graticule.
- b. CHECK—Eleventh time mark should align with the right hand edge of the CRT graticule within 0.3 division (0.4 division if this measurement is being made outside the +20°C to +30°C temperature range).
- c. ADJUST—Horizontal Gain adjustment R817 (see Fig. 5-11) for one one-millisecond time mark per division.

32. Adjust Magnifier Registration

- a. Set the Time-Mark Generator for 5 ms time marks.
- b. With the TIME/DIV switch set to 1 ms, set the MAG switch to 20 μ s (50X magnification).
- c. Horizontally position the middle time mark to the center vertical graticule line.

- d. Set the MAG switch to 1 ms (1X magnification).

e. CHECK—Middle time mark should remain aligned with the center vertical graticule line within approximately one division.

f. ADJUST—Magnifier Registration adjustment R868 (see Fig. 5-11) to align the middle time mark with the center vertical graticule line.

g. Repeat steps b through f until the middle time mark remains aligned with the center vertical graticule line.

33. Check Variable TIME/DIV Range

- a. Set the Time-Mark Generator for 10 ms time marks.
- b. Rotate the Variable TIME/DIV control through its range of adjustment and set for minimum spacing between time marks.
- c. CHECK—CRT display for four or less divisions between time marks when Variable TIME/DIV control is set to minimum. This indicates a Variable range of adjustment of at least 2.5:1.

34. Adjust High Speed Timing

- a. Set the TIME/DIV switch to .2 μ s.
- b. Set the Time-Mark Generator for .1 μ s time marks.
- c. CHECK—CRT display for two time marks per division within 0.3 division (0.4 division if this measurement is being made outside of the +20°C to +30°C temperature range).
- d. ADJUST—C716 (see Fig. 5-11) for two time marks per division.
- e. With the TIME/DIV switch set to .2 μ s, set the MAG switch to .02 μ s.
- f. Set the Time-Mark Generator for 10 nanosecond sine wave (20 nanosecond sine wave if using a Type 184).
- g. CHECK—CRT display for two cycles per division (one cycle per division if using a 20 nanosecond sine wave)

within 0.4 division (0.5 division if this measurement is being made outside of the +20°C to +30°C temperature range). Exclude the first and last two divisions of the magnified sweep.

h. ADJUST—C871 and C881 (see Fig. 5-11) for best timing and linearity excluding the first and last two divisions of the magnified sweep.

i. Set the TIME/DIV switch to 1 μs and the MAG switch to .02 μs. Set the VOLTS/DIV switch to 2 mV/DIV.

j. CHECK—CRT display for two cycles per division (one cycle per division if using a 20 nanosecond sine wave) within 0.4 division (0.5 division if this measurement is being made outside of the +20°C to +30°C temperature range). Exclude the first and last ten divisions of magnified sweep.

k. ADJUST—C871 and C881 (see Fig. 5-11) as necessary for the best compromise of timing and linearity between 1 μs with 50X magnification and .2 μs with 10X magnification.

35. Check TIME/DIV Accuracy

a. CHECK—Apply the appropriate time marks and check each position of the TIME/DIV switch for proper timing (unmagnified) over the first ten divisions of sweep within 0.3 division (0.4 division if this measurement is being made outside of the +20°C to +30°C temperature range).

36. Check Magnified Sweep Accuracy

a. Set the TIME/DIV switch to 1 ms.

b. CHECK—Apply the appropriate time marks and check magnified timing at .5 ms, .2 ms, .1 ms, 50 μs, and 20 μs within 0.4 division (0.5 division if this measurement is being made outside of the +20°C to +30°C temperature range).

c. Set the TIME/DIV switch to .5 ms.

d. CHECK—Apply the appropriate time marks and check magnified timing at .2 ms and 20 μs within 0.4 division (0.5 division if this measurement is being made outside of the +20°C to +30°C temperature range).

e. Set the TIME/DIV switch to .2 ms.

f. CHECK—Apply the appropriate time marks and check magnified timing at 50 μs and 5 μs within 0.4 division (0.5 division if this measurement is being made outside of the +20°C to +30°C temperature range).

37. Check High Speed Magnified Timing Accuracy

a. CHECK—Timing accuracy of TIME/DIV and MAG switch combinations given in Table 5-6 within 0.4 division (0.5 division if this measurement is being made outside of the +20°C to +30°C temperature range).

TABLE 5-6

High Speed Magnified Timing Accuracy

TIME/DIV	MAG	Portions Excluded
1 μs	.5 μs	First and last .5 division.
	.2 μs	First and last 1 division.
	.1 μs	First and last 2 divisions.
	.05 μs	First and last 5 divisions.
	.02 μs	First and last 10 divisions.
.5 μs	.2 μs	First and last .5 division.
	.1 μs	First and last 1 division.
	.05 μs	First and last 2 divisions.
	.02 μs	First and last 5 divisions.
.2 μs	.1 μs	First and last .5 division.
	.05 μs	First and last 1 division.
	.02 μs	First and last 2 divisions.

b. Disconnect all test equipment.

38. Check External Horizontal Sensitivity

a. Set the TIME/DIV switch to EXT HORIZ and the TRIGGER LEVEL control fully clockwise.

b. Connect the output of the Standard Amplitude Calibrator to the EXT HORIZ input connector via a 42-inch 50 Ω BNC cable.

c. Set the Standard Amplitude Calibrator for a two-volt output signal amplitude.

d. CHECK—CRT display for two dots horizontally separated by approximately four divisions (typically within 3.5 to 4.5 divisions).

e. Disconnect all test equipment.

CALIBRATOR CIRCUIT ADJUSTMENT

Equipment Required

- | | |
|---------------------------|----------------------------------|
| 1. Precision DC Voltmeter | 3. 42-Inch 50 Ω BNC Cable |
| 2. Time-Mark Generator | 4. 3-Inch Screwdriver |

Control Settings

Preset the Instrument controls to the settings given under Preliminary Control Settings except as follows:

Sweep MODE	AUTO
INTENSITY	Visible Display
Vertical Mode	ALT

39. Adjust Calibrator Output Voltage Amplitude

- a. Remove Q905 from its socket (see Fig. 5-12).
- b. Connect the Precision DC Voltmeter between the PROBE CAL 0.6 V 1 kHz connector and ground.
- c. CHECK—DC voltage measurement of 0.6 volt within 0.003 volt (0.009 volt if this measurement is being made outside of the +20°C to +30°C temperature range).
- d. ADJUST—R915 (see Fig. 5-12) for a DC voltage measurement of 0.6 volt.

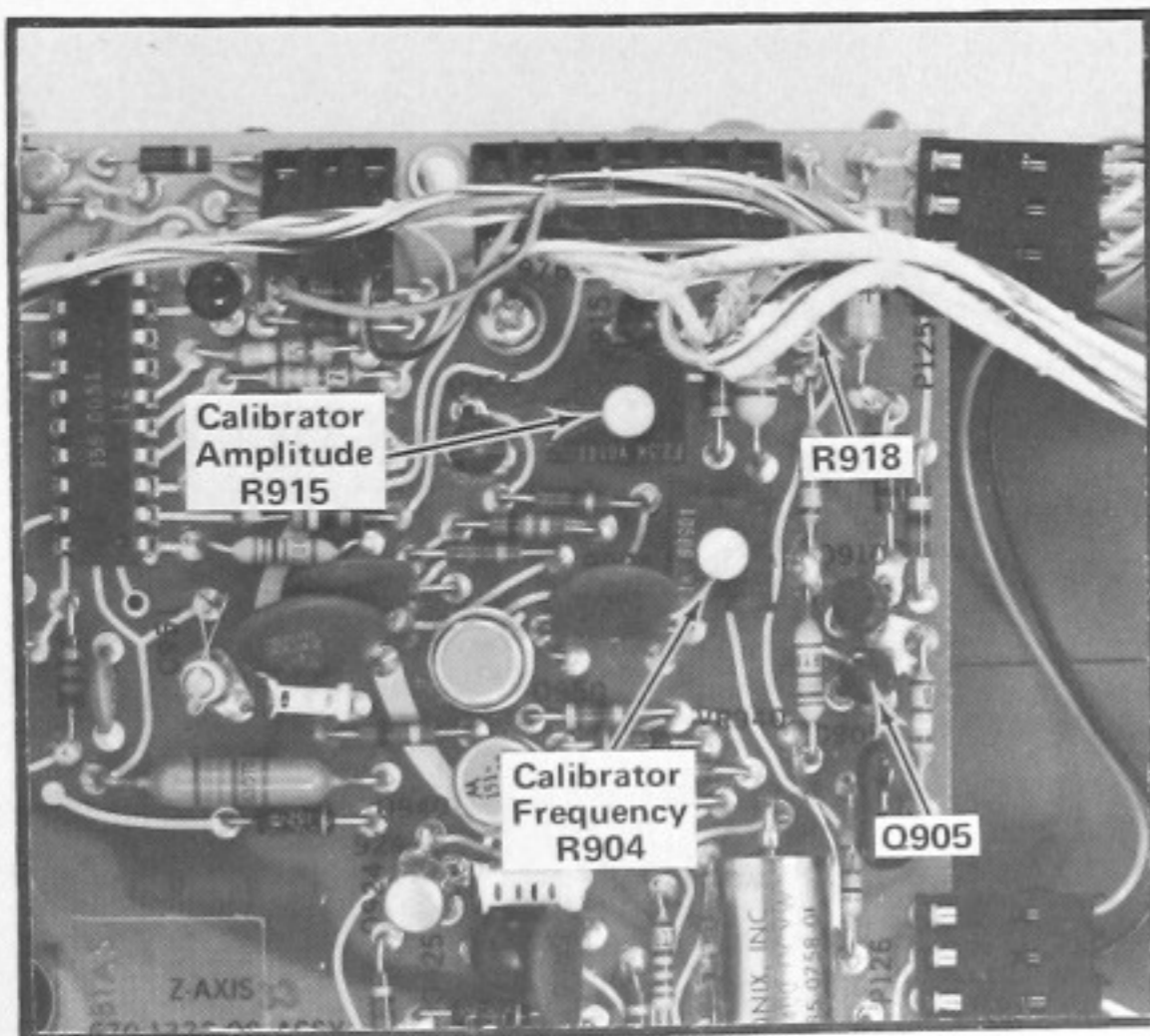

Fig. 5-12. Location of Calibrator circuit components.

- e. Disconnect the Precision DC Voltmeter and replace Q905 in its socket.

40. Adjust Calibrator Repetition Rate

NOTE

If a frequency counter with an accuracy of at least 0.1% is available (such as Tektronix 7D14 Digital Counter), it can be used to check the accuracy of the Calibrator.

- a. Connect a 10X probe (432 standard accessory) to the CH 1 input connector. Connect the tip of the probe to the top of R918 (see Fig. 5-12).
- b. Connect the output of the Time-Mark Generator to the CH 2 input connector via a 42-inch 50 Ω BNC cable. Set the Time-Mark Generator for 1 millisecond time marks.
- c. Adjust the VOLTS/DIV switches for approximately two divisions of display of each signal.
- d. Set the Vertical Mode to ADD.
- e. Adjust the TRIGGER LEVEL control so a triggered trace is presented only when the time marks occur during the positive portion of the calibrator square wave.
- f. Set the TRIGGER COUPLING to LF REJ, the Sweep MODE to NORM, and the TIME/DIV to .2 S/DIV.
- g. CHECK—The amount of time required for a time-mark to drift across the positive level of the calibrator square wave to the negative level and back to the positive level must be at least 0.4 second (0.1 second if this measurement is being made outside of the +20°C to +30°C temperature range). This time can be measured directly from the display by observing the number of divisions that the time mark moves across the display area before it returns to the positive level.

h. ADJUST—If the limits of the CHECK— step are not met set the TRIGGER SOURCE to CH 1, TRIGGER COUPLING to AC, and the TIME/DIV to .2 ms. Adjust the TRIGGER LEVEL control for a stable display and adjust Calibrator Frequency adjustment R904 (see Fig. 5-12) for minimum drift of the time marks across the calibrator waveform. Recheck repetition rate accuracy in the manner given in steps a through g.

i. Disconnect all test equipment.

This completes the calibration procedure for the 432 Oscilloscope. Replace the instrument wrap-around cabinet. If the instrument has been completely checked and adjusted to the tolerances given in this procedure, it will meet or exceed the specifications given in Section 1.

SELECTING COMPONENTS FOR OPTIMUM FOCUS AFTER CRT REPLACEMENT

The CRT focus circuit contains two selectable resistors. If the adjustment covered in step 6 of the Calibration procedure do not result in optimum focus after the CRT has been replaced, it may be necessary to select a new value for R964 or R83 as follows:

SELECTING R964

If optimum focus is not reached before the limit of adjustment of R968 as outlined in Calibration section Step 6.d. (Adjustment of focus range), R964 (which is in parallel with R962C) should be changed in value. Leave the adjustment of R968 at the limit closest to optimum focus and proceed as follows:

1. Turn the instrument off and disconnect it from the power line. Remove the clear plastic protective cover from the Z-Axis board by loosening the nylon screws and slipping the cover sideways so that the screw heads fit through the key-holes in the cover.

2. Measure the resistance of R968 by connecting one probe of the ohmmeter to the junction of R968 and R82B, and the other probe to the junction of R968 and R962C.

3. If R968 is near 5 megohms, R964 value should be increased. Complete removal should suffice. If R968 is near zero ohms, the value of R964 should be decreased. If no resistor was originally installed for R964, a value of 5 to 10 megohms (1/2 watt composition) should suffice. One end of R964 connects to the terminal closest to R968 on R962 (the white ceramic resistor located under C990). The other end of R964 connects to TP962 (one end of C990). When soldering to the terminal on the ceramic resistor, make the

connection as close to the circuit board as possible, and use only enough heat to make a good connection to avoid loosening the terminal on the ceramic resistor.

4. Replace the clear plastic protective cover, apply power and return to Step 6.d. of the calibration procedure.

NOTE

If a value of R964 below 3 megohms is required, a circuit problem is indicated. Remove power from the instrument and use an ohmmeter to check all connections and all resistor values to within 20%. Check connections between the circuit board and R82B for correct order. Restore power to the instrument and recheck the High-Voltage power supply at TP962 for -3940 volts per Step 4 of the Calibration procedure.

SELECTING R83

R83 is selected for optimum tracking of the focus voltage with changes in the INTENSITY control setting. Optimum focus at high intensity should be checked at a fast sweep speed but a low sweep repetition rate, as this is the most common usage of high intensity levels. Good focus at high intensity is critical to single shot photography (or single-shot storage in a storage instrument) near the writing speed limit.

To check focus at high intensity—

1. Turn off the instrument and disconnect it from the power line. Use an ohmmeter to determine which direction of rotation causes an increasing resistance in R968 (Focus Range Adjust). Note this information, remove ohmmeter, restore power and turn the instrument on.

2. Connect the Medium-Frequency signal generator to CH 2 input with a T connector, and to one vertical input of the test oscilloscope terminated in 50Ω . Use a channel on the test oscilloscope which can be selected for triggering (on a 432 or 434 test oscilloscope, this is CH 1 with trigger source set to CH 1). Set the generator to about 350 kHz and obtain a stable triggered display on the test oscilloscope.

3. Connect the + Gate output of the test oscilloscope to the CH 1 input of the instrument being calibrated. Select CH 1 with both the vertical mode switch and trigger source switch on the oscilloscope being calibrated. Obtain a stable display of the test oscilloscope + Gate signal displayed on the instrument being calibrated, triggered on the rising edge.

Calibration—432

4. On the oscilloscope being calibrated, select CH 2, set the TIME/Div to $1\ \mu\text{s}$, and adjust the CH 2 VOLTS/DIV and VAR VOLTS/DIV for 1.5 to 2 divisions of vertical display amplitude. The display should be stable if the test oscilloscope is properly triggered on the 350 kHz signal, and the oscilloscope being calibrated is properly triggered on the test oscilloscope + Gate signal leading edge.
5. Change the test oscilloscope sweep rate to $100\ \mu\text{s}/\text{DIV}$. As the test oscilloscope TIME/DIV is increased (sweep speed slowed down) the display on the instrument being calibrated should become dimmer.
6. Connect the X10 probe to the unused channel of the test oscilloscope and select 20 V/DIV (including X10 probe attenuation factor) on this channel. Connect the probe tip to TP924. Select this channel while continuing to trigger the test oscilloscope on the 350 kHz sine-wave signal. The unblanking waveform should appear as a narrow pulse at the start of the sweep.
7. On the oscilloscope being calibrated, select CH 1 trigger source, and adjust the INTENSITY control clockwise until the top part of the unblanking pulse displayed on the test oscilloscope just reaches its maximum. Do not advance the control past this point.
8. Adjust R968 (using a tool insulated for at least 4000 volts) for optimum focus (minimum trace thickness in all parts of the sine wave, without dark shadows appearing in the center of the trace). Rotate R968 through the focus point several times to verify the optimum point.
9. Select COMP trigger on the oscilloscope being calibrated, and re-adjust trigger level for a stable display. (The trace should be brighter than in step 8.) Reduce intensity to a very low level.
10. Readjust R968 for optimum focus of this low intensity display. Note the direction of rotation required.
11. If the direction of rotation is for increasing resistance (refer to step 2 above) replace R83 with a resistor of higher value (1/2 watt composition resistor). Complete removal of R83 is suggested as the first step. If the direction of rotation is for decreasing resistance, replace R83 with a lower value resistor (approximately 50% changes of R83 value are appropriate for first trial). 10 megohms is the probable minimum value required. (If a value below 5 megohms is indicated, a circuit problem is likely, and checks should be followed as outlined in the selection of R964.
12. After changing the R83 value, repeat the foregoing steps 7 through 12.

SECTION 6

RACKMOUNTING

Change information, if any, affecting this section will be found at the rear of this manual.

Introduction

The Tektronix R432 Oscilloscope is designed to mount in a standard 19-inch rack. When mounted in accordance with the following mounting procedure this instrument will meet all electrical and environmental characteristics given in section 1.

Rack Dimensions

Height. At least 5 1/4 inches of vertical space is required to mount this instrument in a rack.

Width. Minimum width of the opening between the left and right front rails of the rack must be 17 5/8 inches.

Depth. Total depth necessary to mount the R432 in a cabinet rack is 18 inches. This allows room for air circulation, power cord connection and the necessary mounting hardware.

Mounting Procedure

The following mounting procedure uses the Rack Adapter Assembly and the included Rackmount Hardware Kit to insure meeting the environmental characteristics of the instrument. If alternative methods of mounting are used, the instrument may not meet the given environmental characteristics for shock and vibration.

Use the following procedure to install the R432 in a rack:

1. Remove the instrument from the Rack Adapter Assembly in the manner given for cabinet removal in section 4 of this manual.
2. Select the proper front-rail mounting holes in the instrument using the measurements shown in Fig. 6-1.
3. Slide the Rack Adapter Assembly into the rack and align the screw-holes in the Rack Adapter Assembly front panel with the screw holes in the rack front rails that were selected in step 2.

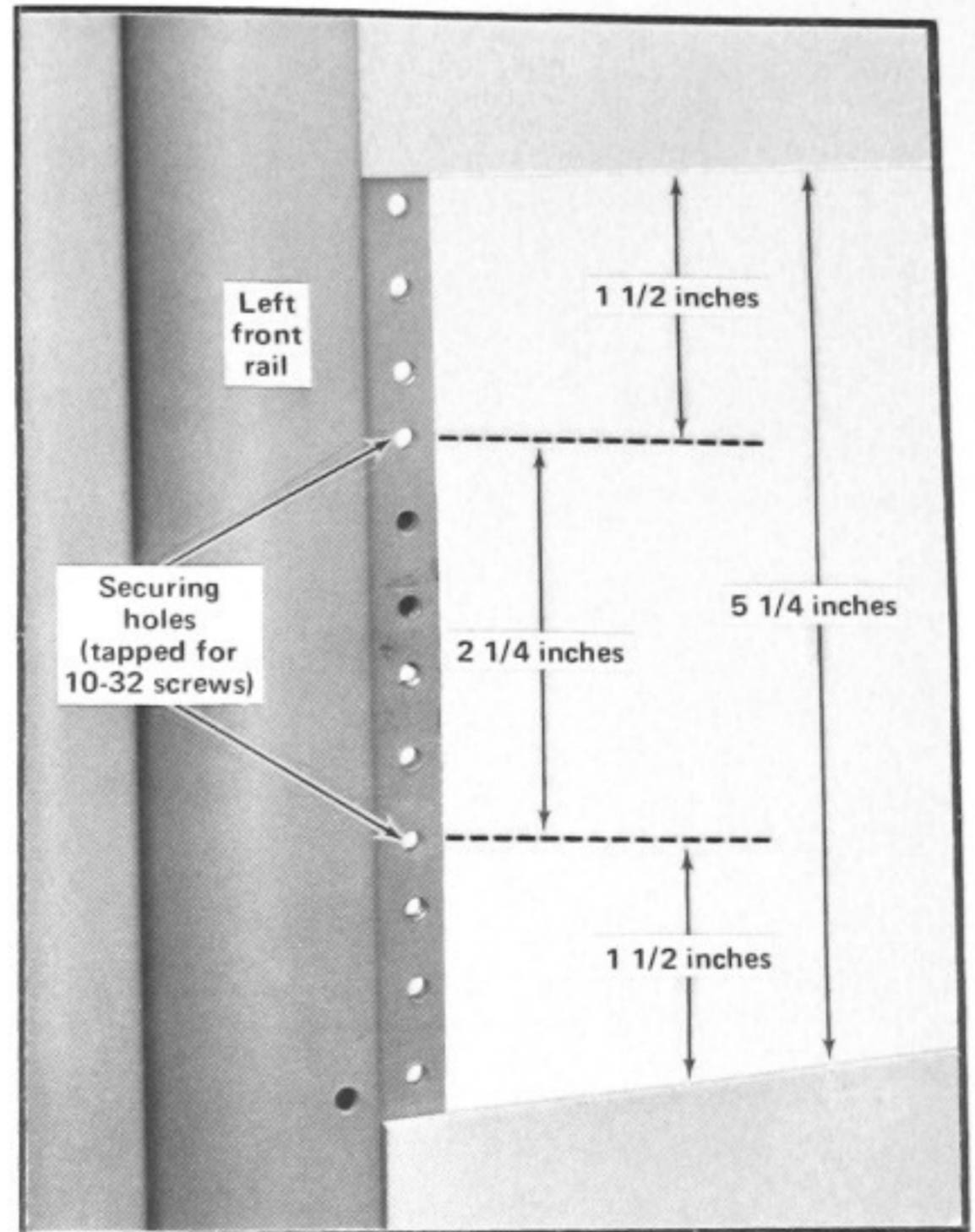

Fig. 6-1. Locating the mounting holes in the rack front rails.

4. Secure the Rack Adapter Assembly to the front rails of the rack. Use the appropriate screws with a plastic washer and finishing washer on each screw from the hardware kit provided. See Figs. 6-2 and 6-3.

5. Position the bracket extensions (provided in the hardware kit) over the rear supports of the Rack Adapter Assembly.

6. Using the Rack Adapter Assembly and the rear rack rails as guides, loosely secure the bracket extensions to the rear supports of the Rack Adapter Assembly approximately in their final permanent positions. Refer to Fig. 6-4.

7. Secure the bracket extensions to the rear rails of the rack. Refer to Fig. 6-4 for hardware and positioning information.

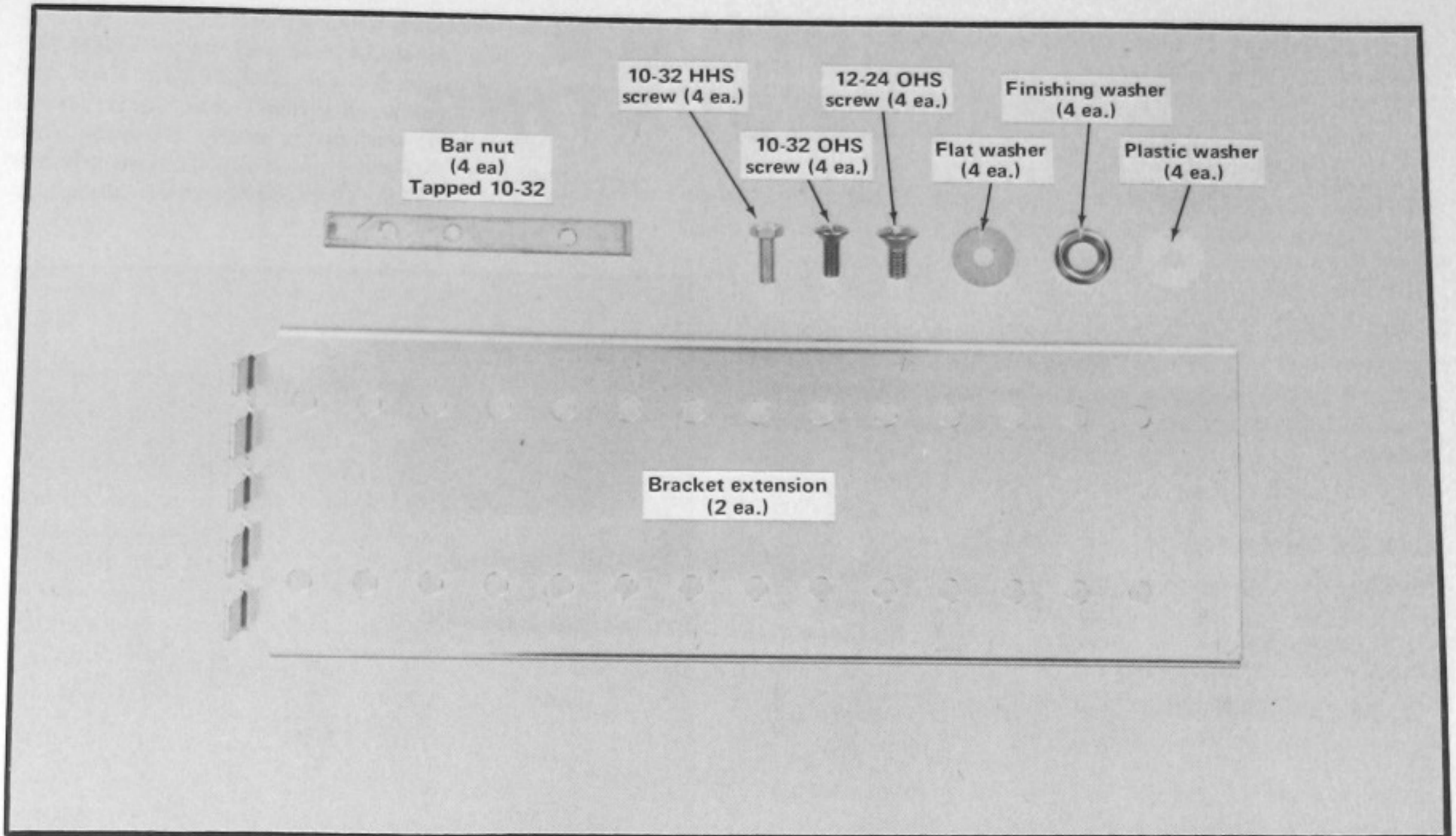

Fig. 6-2. Hardware needed to mount the instrument in the cabinet rack.

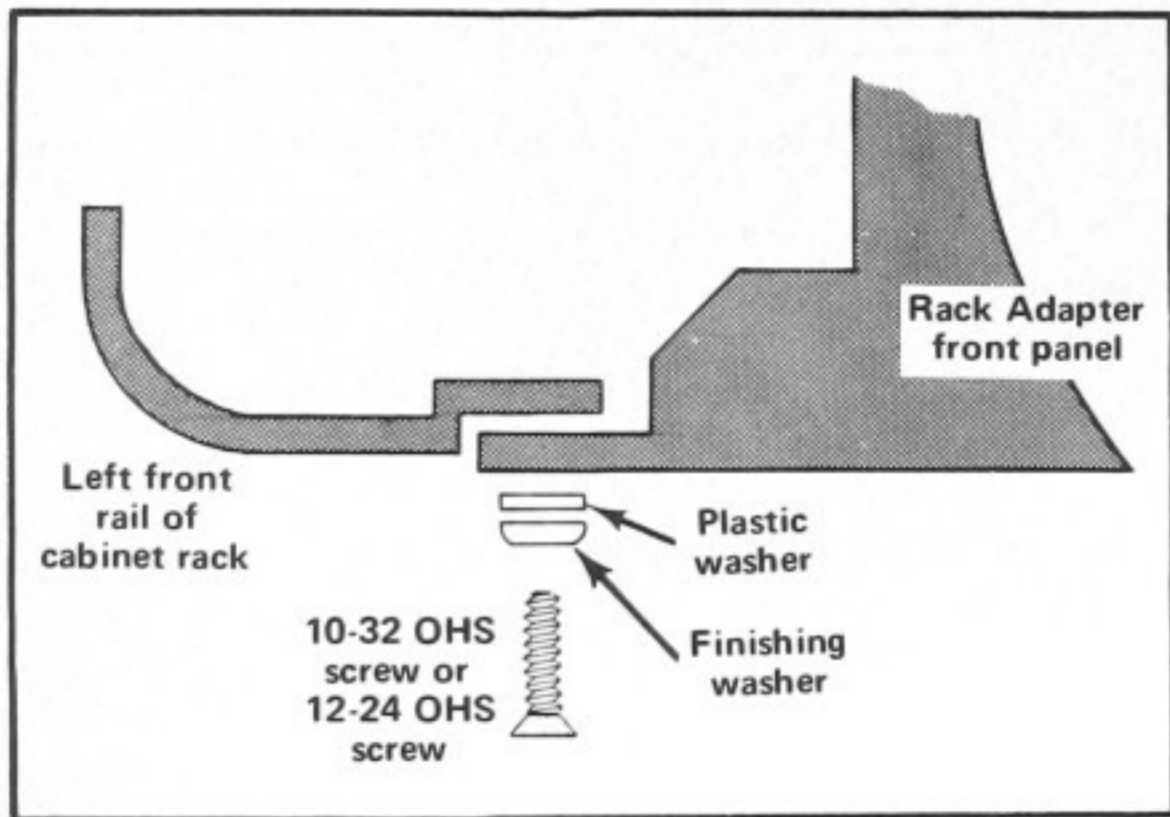

Fig. 6-3. Mounting the instrument to the front rails.

8. Tighten the hardware securing the bracket extensions to the rear supports of the Rack Adapter Assembly. The Rack Adapter Assembly should now be completely installed in the rack.

9. Install the 432 Oscilloscope in the Rack Adapter Assembly in the manner given in section 4 of this manual.

Portable Conversion

The 432 is readily converted from a rack-mounted instrument to a portable instrument or vice versa. To rackmount a portable 432, order the Rack Adapter Assembly Tektronix Part Number 016-0272-00. Remove the instrument from the portable wrap-around cabinet and install it in the Rack Adapter Assembly.

Conversely, to use an R432 as a portable instrument, order the 432 portable oscilloscope wrap-around cabinet Tektronix Part Number 390-0187-00 and the front cover Tektronix Part Number 200-1203-00. Remove the instrument from the Rack Adapter Assembly and install the portable wrap-around and front cover. Refer to section 4 of this manual for instrument removal instructions.

Rear Panel Signal Connections

The three signal input connectors on the rear panel of the 432 are not readily accessible when the instrument is rack mounted. Provisions have been made, however, to make these inputs available at the front panel of the instrument if so desired. Each signal connection requires one 30-inch 50-ohm BNC cable Tektronix Part Number 012-0117-00, one chassis-mount BNC thru-connector Tektronix Part Number 103-0070-00, and, if vertical clearance

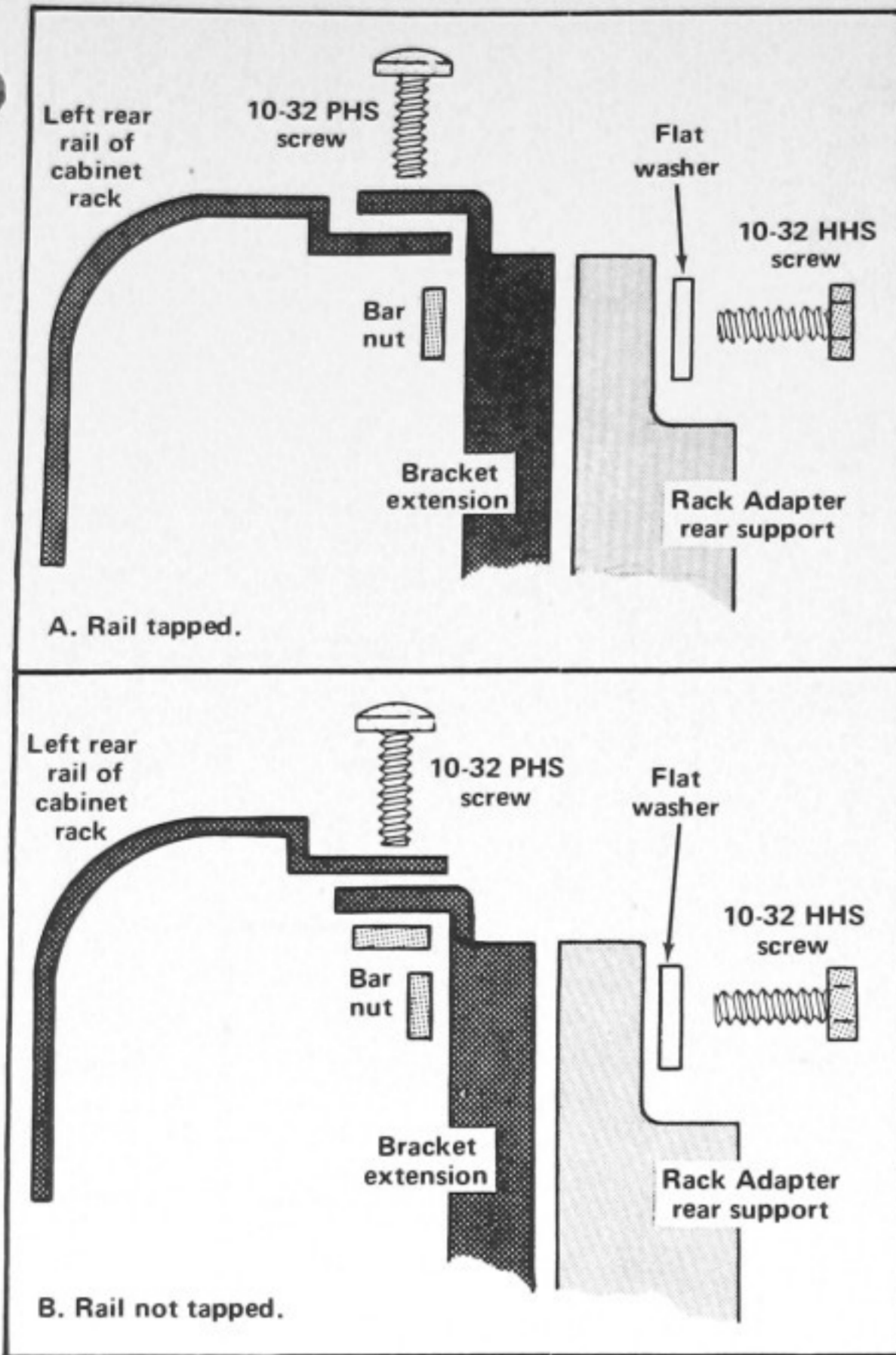

Fig. 6-4. Installing the rear bracket extensions.

above the rear panel connectors is less than approximately 1 1/4 inches, one BNC 90° elbow Tektronix Part Number 103-0031-00.

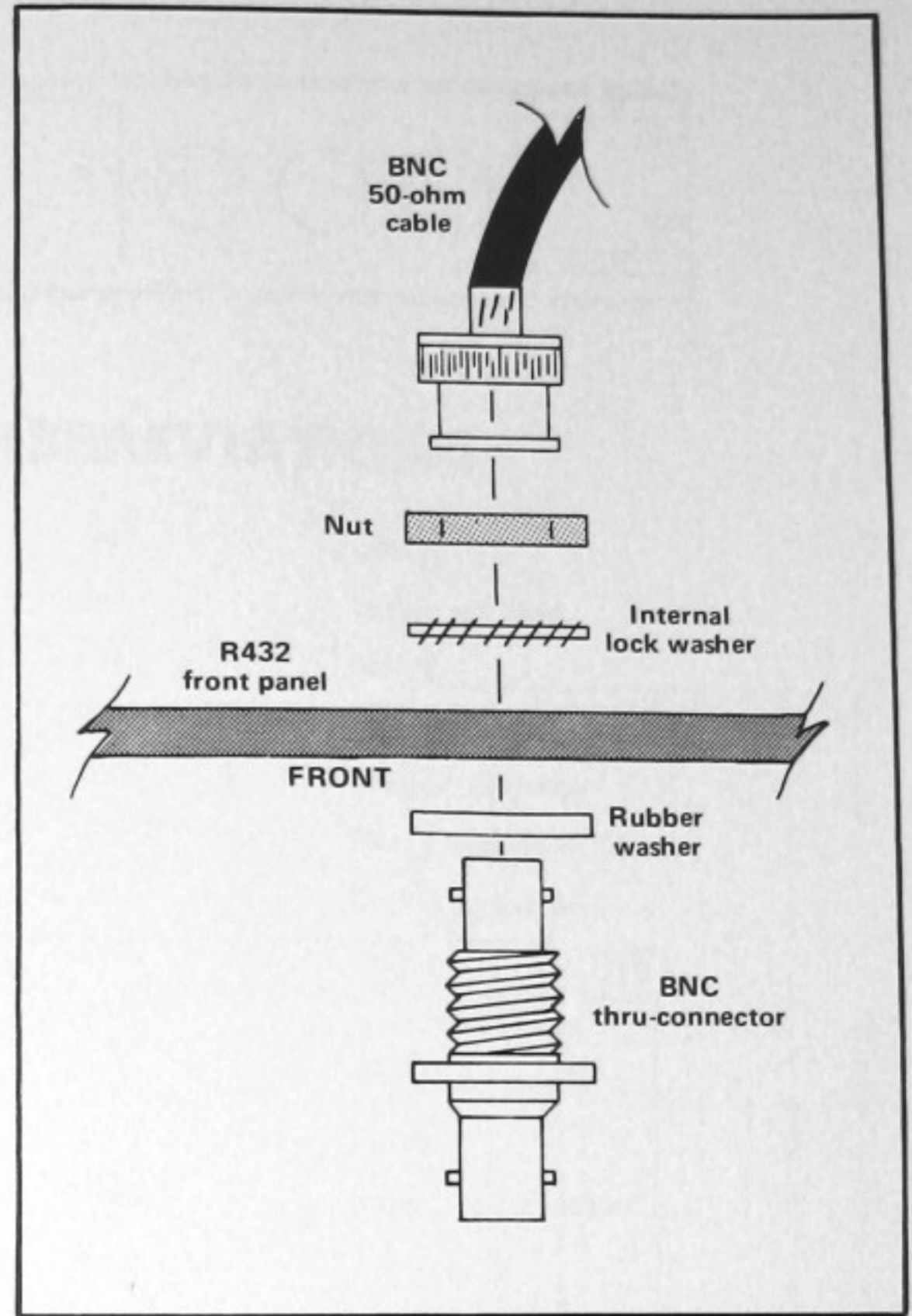

Fig. 6-5. Mounting a chassis-mount BNC thru-connector.

Remove a plastic plug from the front panel of the R432. Mount a BNC thru-connector in the hole in the front panel (see Fig. 6-5). Connect the newly-mounted BNC connector to the desired rear-panel input connector with the 30-inch 50-ohm BNC cable. If insufficient vertical clearance is available over the rear panel connector, use the BNC 90° elbow to make the connection.

Rackmounting-432

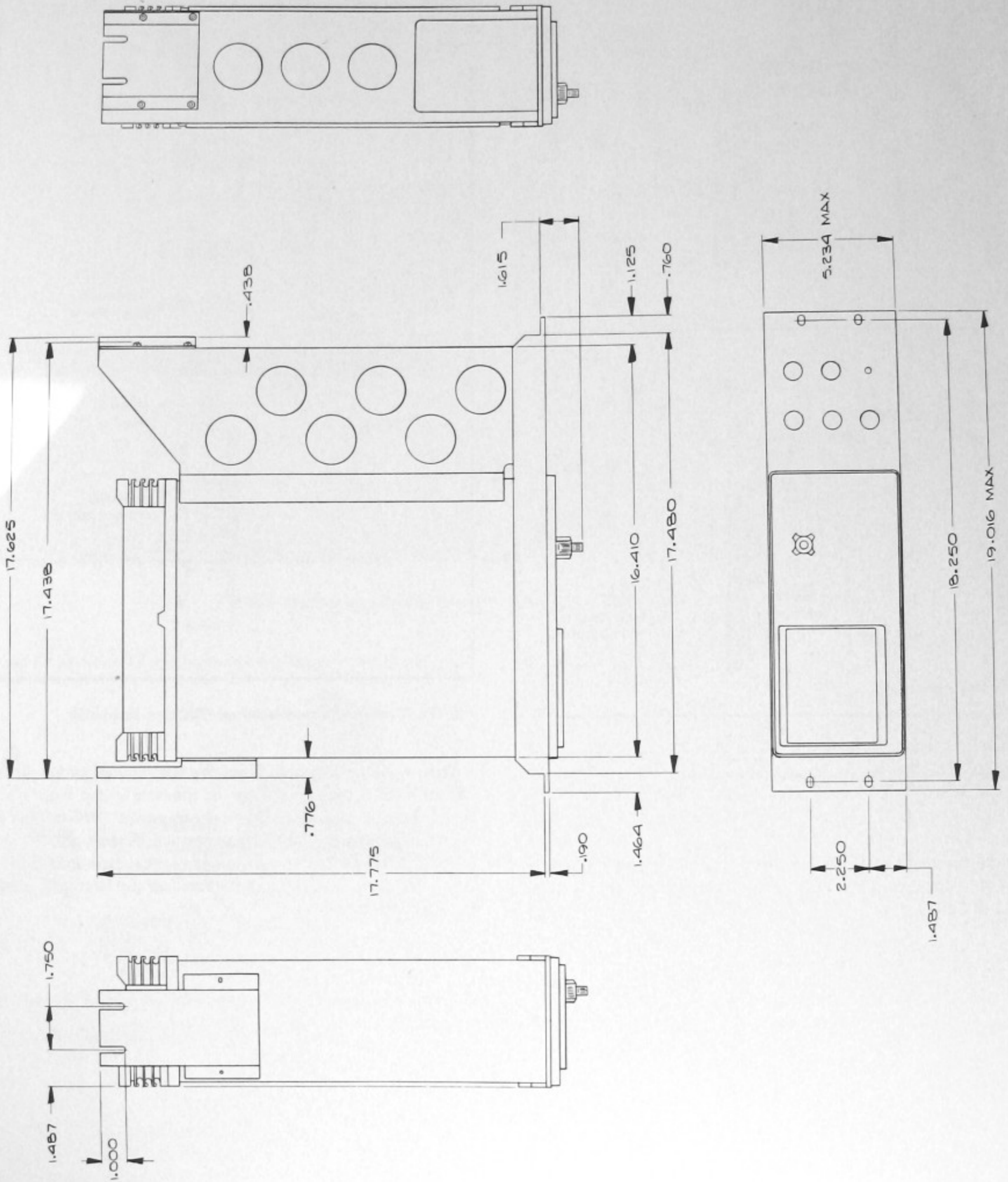

Fig. 6-6. Dimensional drawing.

PARTS LIST ABBREVIATIONS

BHB	binding head brass	int	internal
BHS	binding head steel	lg	length or long
cap.	capacitor	met.	metal
cer	ceramic	mtg hdw	mounting hardware
comp	composition	OD	outside diameter
conn	connector	OHB	oval head brass
CRT	cathode-ray tube	OHS	oval head steel
csk	countersunk	P/O	part of
DE	double end	PHB	pan head brass
dia	diameter	PHS	pan head steel
div	division	plstc	plastic
elect.	electrolytic	PMC	paper, metal cased
EMC	electrolytic, metal cased	poly	polystyrene
EMT	electrolytic, metal tubular	prec	precision
ext	external	PT	paper, tubular
F & I	focus and intensity	PTM	paper or plastic, tubular, molded
FHB	flat head brass	RHB	round head brass
FHS	flat head steel	RHS	round head steel
Fil HB	fillister head brass	SE	single end
Fil HS	fillister head steel	SN or S/N	serial number
h	height or high	S or SW	switch
hex.	hexagonal	TC	temperature compensated
HHB	hex head brass	THB	truss head brass
HHS	hex head steel	thk	thick
HSB	hex socket brass	THS	truss head steel
HSS	hex socket steel	tub.	tubular
ID	inside diameter	var	variable
inc	incandescent	w	wide or width
		WW	wire-wound

PARTS ORDERING INFORMATION

Replacement parts are available from or through your local Tektronix, Inc. Field Office or representative.

Changes to Tektronix instruments are sometimes made to accommodate improved components as they become available, and to give you the benefit of the latest circuit improvements developed in our engineering department. It is therefore important, when ordering parts, to include the following information in your order: Part number, instrument type or number, serial or model number, and modification number if applicable.

If a part you have ordered has been replaced with a new or improved part, your local Tektronix, Inc. Field Office or representative will contact you concerning any change in part number.

SPECIAL NOTES AND SYMBOLS

- ×000 Part first added at this serial number
- 00× Part removed after this serial number
- *000-0000-00 Asterisk preceding Tektronix Part Number indicates manufactured by or for Tektronix, Inc., or reworked or checked components.
- Use 000-0000-00 Part number indicated is direct replacement.

SECTION 7

ELECTRICAL PARTS LIST

CHASSIS

Values are fixed unless marked Variable.

Ckt. No.	Tektronix Part No.	Serial/Model No. Eff	No. Disc	Description		
Capacitors						
Tolerance $\pm 20\%$ unless otherwise indicated.						
C5	283-0023-00		0.1 μF	Cer	10 V	
C15	283-0023-00		0.1 μF	Cer	10 V	
C22	283-0067-00		0.001 μF	Cer	200 V	10%
C32	283-0067-00		0.001 μF	Cer	200 V	10%
C536	283-0057-00		0.1 μF	Cer	200 V	+80% -20%
C1016	290-0515-00		200 μF	Elect.	450 V	+50% -10%

Semiconductor Device, Diodes

CR1084	152-0413-00		Silicon	Rectifier, fast recovery, 400 V, 0.75 A		
VR1084	152-0298-00		Zener	1N3816	1.5 W, 140 V, 5%	
VR1085	152-0297-00		Zener	1N3814B	1.5 W, 110 V, 5%	

Delay Line Assembly

DL500	*119-0267-01		Delay line assembly			
-------	--------------	--	---------------------	--	--	--

Bulbs

DS20	150-0109-00		Incandescent, 18 V, 26 mA			
DS22	150-0109-00		Incandescent, 18 V, 26 mA			
DS30	150-0109-00		Incandescent, 18 V, 26 mA			
DS32	150-0109-00		Incandescent, 18 V, 26 mA			
DS65	150-0035-00		Neon, A1D-T 0.3 mA			

Fuse

F1000	159-0016-00		Cartridge	1.5 A	Fast-Blo	
-------	-------------	--	-----------	-------	----------	--

Electrical Parts List—432/R432

CHASSIS (cont)

Ckt. No.	Tektronix Part No.	Serial/Model No. Eff	Disc	Description
Connectors				
J1	131-0679-00			BNC, receptacle, electrical
J10	131-0679-00			BNC, receptacle, electrical
J70	131-0955-00			BNC, receptacle, electrical
J80	131-0955-00			BNC, receptacle, electrical
J85	131-0955-00			BNC, receptacle, electrical
J95	136-0098-01			Jack, Tip
Inductors				
L100	*108-0657-00			Beam rotator
L533	*114-0309-00			9.6-18.7 μ H, Var Core 276-0511-00
L584	*114-0309-00			9.6-18.7 μ H, Var Core 276-0511-00
LR9	*108-0286-00			0.17 μ H (wound on a 36 Ω , 1/8 W, 5% resistor)
LR19	*108-0286-00			0.17 μ H (wound on a 36 Ω , 1/8 W, 5% resistor)
LR533	*108-0659-00			1.5 μ H (wound on a 1.6 k Ω , 1/4 W, 5% resistor)
LR584	*108-0659-00			1.5 μ H (wound on a 1.6 k Ω , 1/4 W, 5% resistor)
Transistors				
Q530	*151-0124-00			Silicon NPN TO-5 Selected from 2N3119
Q580	*151-0124-00			Silicon NPN TO-5 Selected from 2N3119
Q1080	*151-0314-00			Silicon NPN TO-3 Replaceable by 2N5157
Resistors				
Resistors are fixed, composition, $\pm 10\%$ unless otherwise indicated.				
R22	311-0546-00			10 k Ω , Var
R32	311-0546-00			10 k Ω , Var
R40	311-1115-00			5 k Ω x 5 k Ω , Var
R41	321-0121-00			178 Ω 1/8 W Prec 1%
R42	321-0121-00			178 Ω 1/8 W Prec 1%
R44	311-1115-00			5 k Ω x 5 k Ω , Var
R50	315-0271-00			270 Ω 1/4 W 5%
R55 A, B	311-0429-00			100 k Ω x 10 k Ω , Var
R60 A, B ¹	311-1117-00			10 k Ω x 50 k Ω , Var
R80	311-0086-00			2.5 k Ω , Var
R82 A, B	311-1207-00			5 M Ω x 1 k Ω , Var
R83	301-0166-00	B010100	B059999	16 M Ω 1/2 W 5%
R83 ²	Selected	B060000	B060479	16 M Ω (nominal value)
R83	301-0166-00	B060480		16 M Ω (nominal value) Selected
R85	311-1200-00			100 k Ω , Var
R86	311-0647-00	XB190000		5 M Ω , Var
R535	*310-0694-00			1.25 k Ω 10 W WW 1%
R536	303-0470-00			47 Ω 1 W 5%

¹Furnished as a unit with S60.²Added if necessary. See end of Section 5 Calibration Section.

CHASSIS (cont)

Ckt. No.	Tektronix Part No.	Serial/Model No. Eff	No. Disc	Description			
Resistors (cont)							
R586	*310-0694-00			1.25 kΩ	10 W	WW	1%
R1002	308-0555-00	B010100	B139999	5 Ω	3 W		5%
R1002	308-0179-00	B140000		5 Ω	5 W	WW	5%
R1016	306-0474-00			470 kΩ	2 W		
Switches							
	Wired or Unwired						
S50	260-0735-00			Push		BEAM FINDER	
S60 ¹						SLOPE	
S65	260-1229-00	B010100	B219999	Pushbutton		MODE	
S65	260-1229-01	B220000		Pushbutton		MODE	
S68	260-0735-00			Push		RESET	
S1002	260-0724-00	B010100	B139999	Thermo, opens at 83.3°C, closes at 66.3°C			
S1002	260-0879-00	B140000		Thermo, opens at 88.3°C, closes at 71.7°C			
Electron Tube							
V100	*154-0632-10	B010100	B119999	CRT			
V100	*154-0665-00	B120000	B169999	CRT			
V100	*154-0665-05	B170000		CRT			

A1 INPUT AMPLIFIER Circuit Board Assembly

*670-1357-00

Complete Board

Tolerance ±20% unless otherwise indicated.

Capacitors

C121	283-0001-00		0.005 μF	Cer	500 V	
C124	283-0111-00		0.1 μF	Cer	50 V	
C125	283-0080-00		0.022 μF	Cer	25 V	+80%—20%
C126	283-0111-00		0.1 μF	Cer	50 V	
C135	283-0023-00		0.1 μF	Cer	10 V	
C171	283-0001-00		0.005 μF	Cer	500 V	
C174	283-0111-00		0.1 μF	Cer	50 V	
C175	283-0080-00		0.022 μF	Cer	25 V	+80%—20%
C176	283-0111-00		0.1 μF	Cer	50 V	
C185	283-0023-00		0.1 μF	Cer	10 V	
C187	290-0517-00		6.8 μF	Elect.	35 V	
C189	290-0517-00		6.8 μF	Elect.	35 V	

¹Furnished as a unit with R60A,B.

Electrical Parts List—432/R432

A1 INPUT AMPLIFIER Circuit Board Assembly (cont)

Ckt. No.	Tektronix Part No.	Serial/Model No. Eff	Disc	Description		
Semiconductor Device, Diodes						
CR122	*152-0321-00		Silicon	Tek Spec		
CR172	*152-0321-00		Silicon	Tek Spec		
VR124	152-0279-00		Zener	1N751A 400 mW, 5.1 V, 5%		
VR126	152-0279-00		Zener	1N751A 400 mW, 5.1 V, 5%		
VR174	152-0279-00		Zener	1N751A 400 mW, 5.1 V, 5%		
VR176	152-0279-00		Zener	1N751A 400 mW, 5.1 V, 5%		
Transistors						
Q124 A, B	151-1032-00		Silicon	FET	TO-78	Dual
Q174 A, B	151-1032-00		Silicon	FET	TO-78	Dual
Resistors						
Resistors are fixed, composition, $\pm 10\%$ unless otherwise indicated.						
R120	321-0481-00		1 M Ω	1/8 W	Prec	1%
R121	316-0104-00		100 k Ω	1/4 W		
R122	316-0470-00		47 Ω	1/4 W		
R125	321-0030-00		20 Ω	1/8 W	Prec	1%
R126	321-0030-00		20 Ω	1/8 W	Prec	1%
R134	315-0393-00		39 k Ω	1/4 W		5%
R135	315-0151-00		150 Ω	1/4 W		5%
R170	321-0481-00		1 M Ω	1/8 W	Prec	1%
R171	316-0104-00		100 k Ω	1/4 W		
R172	316-0470-00		47 Ω	1/4 W		
R175	321-0030-00		20 Ω	1/8 W	Prec	1%
R176	321-0030-00		20 Ω	1/8 W	Prec	1%
R184	315-0393-00		39 k Ω	1/4 W		5%
R185	315-0151-00		150 Ω	1/4 W		5%
R187	315-0820-00		82 Ω	1/4 W		5%
R189	315-0820-00		82 Ω	1/4 W		5%

A2 VERTICAL Circuit Board Assembly

Ckt. No.	Tektronix Part No.	Serial/Model No. Eff	Disc	Description
	*670-1365-00	B010100	B029999	Complete Board
	*670-1365-01	B030000	B179999	Complete Board
	*670-1365-02	B180000		Complete Board
Capacitors				
Tolerance $\pm 20\%$ unless otherwise indicated.				
C216	281-0622-00	B010100	B149999	47 pF Cer 500 V 1%
C216	281-0540-00	B150000		51 pF Cer 500 V 5%
C217	281-0093-00			5.5-18 pF, Var Cer
C220	281-0092-00			9-35 pF, Var Cer
C221	281-0603-00			39 pF Cer 500 V 5%
C222	281-0602-00	B010100	B069999	68 pF Cer 500 V 5%
C222	281-0571-00	B070000	B209999	82 pF Cer 500 V
C222	281-0523-00	B210000	B211809	100 pF (nominal value) Selected
C222	281-0571-00	B211810		82 pF (nominal value) Selected
C223	281-0092-00			9-35 pF, Var Cer
C224	281-0579-00			21 pF Cer 500 V 5%
C225	281-0091-00			2-8 pF, Var Cer
C226	281-0064-00			0.25-1.5 pF, Var Plastic
C227	281-0670-00			1.8 pF Cer 500 V ± 0.1 pF
C228 ¹	281-0509-00	XB230000		15 pF (nominal value) Selected
C231	281-0709-00			7 pF Cer 500 V ± 0.1 pF
C234	283-0111-00			0.1 μ F Cer 50 V
C252	281-0656-00			22 pF Cer 200 V 5%
C253	283-0111-00			0.1 μ F Cer 50 V
C256	283-0000-00			0.001 μ F Cer 500 V
C258	281-0626-00			3.3 pF Cer 200 V 5%
C262	281-0656-00			22 pF Cer 25 V +80%—20%
C272	283-0080-00			0.022 μ F Cer 500 V 10%
C278	281-0536-00	XB050000		1000 pF Cer 25 V +80%—20%
C282	283-0080-00			0.022 μ F Cer 500 V 1%
C316	281-0622-00	B010100	B149999	47 pF Cer 500 V 5%
C316	281-0540-00	B150000		51 pF Cer 500 V 5%
C317	281-0093-00			5.5-18 pF, Var Cer
C320	281-0092-00			9-35 pF, Var Cer
C321	281-0540-00			51 pF Cer 500 V 5%
C322	281-0602-00	B010100	B069999	68 pF Cer 500 V
C322	281-0571-00	B070000	B209999	82 pF Cer 500 V 5%
C322	281-0523-00	B210000	B211809	100 pF (nominal value) Selected
C322	281-0571-00	B211810		82 pF (nominal value) Selected
C323	281-0158-00	B010100	B179999	7-45 pF, Var Cer
C323	281-0123-00	B180000		5-25 pF, Var Cer
C324	283-0109-00			27 pF Cer 1000 V 5%
C325	281-0091-00			2-8 pF, Var Cer
C326	281-0064-00			0.25-1.5 pF, Var Plastic
C327	281-0661-00			0.8 pF Cer 500 V ± 0.1 pF
C328	281-0509-00	XB180000		15 pF Cer 500 V 10%
C331	281-0709-00			7 pF Cer 500 V ± 0.1 pF
C334	283-0111-00			0.1 μ F Cer 50 V
C352	281-0656-00			22 pF Cer 200 V 5%
C353	283-0111-00			0.1 μ F Cer 50 V
C356	283-0000-00			0.001 μ F Cer 500 V
C357	290-0517-00			6.8 μ F Elect. 35 V

¹Added if necessary.

A2 VERTICAL Circuit Board Assembly (cont)

Ckt. No.	Tektronix Part No.	Serial/Model No. Eff	No. Disc	Description		
Capacitors (cont)						
C359	290-0517-00			6.8 μ F	Elect.	35 V
C360	290-0523-00			2.2 μ F	Elect.	20 V
C362	281-0656-00			22 pF	Cer	200 V
C404	290-0523-00			2.2 μ F	Elect.	20 V
C408	290-0523-00			2.2 μ F	Elect.	20 V
C410	290-0523-00			2.2 μ F	Elect.	20 V
C414	290-0523-00			2.2 μ F	Elect.	20 V
C421	281-0629-00			33 pF	Cer	600 V
C424	281-0629-00			33 pF	Cer	600 V
C425	283-0238-00			0.01 μ F	Cer	50 V
C426	290-0523-00			2.2 μ F	Elect.	20 V
C430	283-0060-00			100 pF	Cer	200 V
C435	290-0523-00			2.2 μ F	Elect.	20 V
C436	283-0080-00			0.022 μ F	Cer	25 V
C442	283-0059-00			1 μ F	Cer	25 V
C452	283-0080-00			0.022 μ F	Cer	25 V
C456	281-0622-00	B010100	B149999	47 pF	Cer	500 V
C456	281-0562-00	B150000		39 pF	Cer	500 V
C460	281-0655-00	B010100	B019999	9.7 pF	Cer	500 V
C460 ¹	281-0504-00	B020000		10 pF	(nominal value) Selected	
C461	281-0093-00	B010100	B249999	5.5-18 pF, Var	Cer	
C461	281-0092-00	B250000		9-35 pF, Var	Cer	
C463	283-0010-00			0.05 μ F	Cer	50 V
C471	281-0592-00	XB100000		4.7 pF	Cer	
C472	281-0622-00	B010100	B149999	47 pF	Cer	500 V
C472	281-0562-00	B150000		39 pF	Cer	500 V
C479	281-0551-00			390 pF	Cer	500 V
C500	281-0616-00			6.8 pF	Cer	200 V
C510	283-0111-00			0.1 μ F	Cer	50 V
C525	283-0032-00			470 pF	Cer	500 V
C540	281-0616-00			6.8 pF	Cer	200 V
C565	283-0032-00			470 pF	Cer	500 V
C570	281-0540-00	B010100	B149999	51 pF	Cer	500 V
C570	281-0512-00	B150000		27 pF	Cer	500 V
C572	281-0123-00			5-25 pF, Var	Cer	100 V
C573 ²	281-0558-00	XB150000	B179999	18 pF	(nominal value) Selected	
C573	Selected	B180000				
C578	290-0517-00			6.8 μ F	Elect.	35 V

Semiconductor Device, Diodes

CR256	*152-0185-00			Silicon	Replaceable by	1N4152
CR270	*152-0185-00			Silicon	Replaceable by	1N4152
CR273	*152-0185-00			Silicon	Replaceable by	1N4152
CR275	*152-0185-00			Silicon	Replaceable by	1N4152
CR280	*152-0185-00			Silicon	Replaceable by	1N4152
CR283	*152-0185-00			Silicon	Replaceable by	1N4152
CR285	*152-0185-00			Silicon	Replaceable by	1N4152
CR356	*152-0185-00			Silicon	Replaceable by	1N4152
CR404	152-0141-02			Silicon		1N4152
CR405	152-0141-02			Silicon		1N4152

¹See step 25g of Section 5 Calibration Section.²Added when necessary.

A2 VERTICAL Circuit Board Assembly (cont)

Ckt. No.	Tektronix Part No.	Serial/Model No. Eff	Disc	Description
Semiconductor Device, Diodes (cont)				
CR406	152-0141-02			Silicon 1N4152
CR408	152-0141-02			Silicon 1N4152
CR410	152-0141-02			Silicon 1N4152
CR411	152-0141-02			Silicon 1N4152
CR412	152-0141-02			Silicon 1N4152
CR414	152-0141-02			Silicon 1N4152
CR426	*152-0185-00			Silicon 1N4152
CR428	*152-0185-00			Silicon Replaceable by 1N4152
CR431	*152-0185-00			Silicon Replalceable by 1N4152
CR432	*152-0185-00			Silicon Replalceable by 1N4152
CR433	*152-0185-00			Silicon Replalceable by 1N4152
CR440	*152-0185-00			Silicon Replalceable by 1N4152
CR521	*152-0185-00			Silicon Replalceable by 1N4152
CR551	*152-0185-00			Silicon Replalceable by 1N4152
VR227	152-0279-00			Zener Replalceable by 1N4152
VR327	152-0279-00			Zener 1N751A 400 mW, 5.1 V, 5%
VR525	152-0166-00	XB070000		Zener 1N751A 400 mW, 5.1 V, 5%
VR565	152-0166-00	XB070000		Zener 1N753A 400 mW, 6.2 V, 5%

Transistors

Q200	*151-0281-00			Silicon NPN TO-98 Tek Spec
Q202	*151-0192-00			Silicon NPN TO-92 Replaceable by MPS 6521
Q255	151-0220-00			Silicon PNP TO-18 2N4122
Q265	151-0220-00			Silicon PNP TO-18 2N4122
Q275	151-0221-00			Silicon PNP TO-18 2N4258
Q278	151-0221-00			Silicon PNP TO-18 2N4258
Q280	*151-0190-01			Silicon NPN TO-106 Tek Spec
Q300	*151-0281-00			Silicon NPN TO-98 Tek Spec
Q302	*151-0192-00			Silicon NPN TO-92 Replaceable by MPS 6521
Q355	151-0220-00			Silicon PNP TO-18 2N4122
Q365	151-0220-00			Silicon PNP TO-18 2N4122
Q420	151-0223-00			Silicon NPN TO-18 2N4275
Q425	151-0223-00			Silicon NPN TO-18 2N4275
Q435	151-0223-00			Silicon NPN TO-18 2N4275
Q440	151-0223-00			Silicon NPN TO-18 2N4275
Q454	151-0220-00			Silicon PNP TO-18 2N4122
Q470	151-0220-00			Silicon PNP TO-18 2N4122
Q505	151-0220-00			Silicon PNP TO-18 2N4122
Q515	*151-0198-00			Silicon NPN TO-92 Replaceable by MPS 918
Q520	*151-0230-00			Silicon NPN TO-105 Selected from RCA 40235
Q525	*151-0127-00			Silicon NPN TO-18 Selected from 2N2369
Q545	151-0220-00			Silicon PNP TO-18 2N4122
Q550	*151-0230-00			Silicon NPN TO-105 Selected from RCA 40235
Q555	*151-0198-00			Silicon NPN TO-92 Replaceable by MPS 918
Q565	*151-0127-00			Silicon NPN TO-18 Selected from 2N2369

Inductors

L275	*108-0443-00	XB050000	25 μ H
L285	*108-0443-00	XB050000	25 μ H

A2 VERTICAL Circuit Board Assembly (cont)

Ckt. No.	Tektronix Part No.	Serial/Model No. Eff	Disc	Description		
Resistors						
Resistors are fixed, composition, $\pm 10\%$ unless otherwise indicated.						
R200	316-0274-00			270 k Ω	$\frac{1}{4}$ W	
R202	316-0682-00			6.8 k Ω	$\frac{1}{4}$ W	
R204	316-0152-00			1.5 k Ω	$\frac{1}{4}$ W	
R210	316-0103-00			10 k Ω	$\frac{1}{4}$ W	
R212	311-1232-00			50 k Ω , Var		
R214	316-0103-00			10 k Ω	$\frac{1}{4}$ W	
R216	321-0104-00	B010100	B149999	118 Ω	$\frac{1}{8}$ W	Prec 1%
R216	321-0107-00	B150000		127 Ω	$\frac{1}{8}$ W	Prec 1%
R217 ¹	315-0160-00	B010100	B179999X	16 Ω	$\frac{1}{4}$ W	5%
R219 ²	315-0104-00	XB020000		10 k Ω	$\frac{1}{4}$ W	5%
R220	321-0907-02	B010100	B019999	98 Ω	(nominal value)	Selected
R220	321-0094-00	B020000	B209999	93.1 Ω	(nominal value)	Selected
R220	321-0093-00	B210000	B211809	90.9 Ω	(nominal value)	Selected
R220	321-0094-00	B211810		93.1 Ω	(nominal value)	Selected
R221	315-0331-00			330 Ω	$\frac{1}{4}$ W	5%
R222 ²	315-0183-00	XB020000		18 k Ω	$\frac{1}{4}$ W	5%
R223	321-0131-00	B010100	B019999	226 Ω	$\frac{1}{8}$ W	Prec 1%
R223	321-0131-00	B020000	B209999	226 Ω	(nominal value)	Selected
R223	321-0129-00	B210000	B211809	215 Ω	(nominal value)	Selected
R223	321-0130-00	B211810		221 Ω	(nominal value)	Selected
R224	315-0391-00			390 Ω	$\frac{1}{4}$ W	5%
R225	321-0172-00			604 Ω	$\frac{1}{8}$ W	Prec 1%
R226	321-0151-00			365 Ω	$\frac{1}{8}$ W	Prec 1%
R228	321-0317-00			19.6 k Ω	$\frac{1}{8}$ W	Prec 1%
R229	321-0120-00			174 Ω	$\frac{1}{8}$ W	Prec 1%
R230	321-0172-00			604 Ω	$\frac{1}{8}$ W	Prec 1%
R231	315-0561-00			560 Ω	$\frac{1}{4}$ W	5%
R232	321-0204-00			1.3 k Ω	$\frac{1}{8}$ W	Prec 1%
R235	321-0202-00			1.24 k Ω	$\frac{1}{8}$ W	Prec 1%
R236	321-0172-00			604 Ω	$\frac{1}{8}$ W	Prec 1%
R238	321-0204-00			1.3 k Ω	$\frac{1}{8}$ W	Prec 1%
R240	321-0053-00	B010100	B169999	34.8 Ω	$\frac{1}{8}$ W	Prec 1%
R240	321-0050-01	B170000		32.4 Ω	$\frac{1}{8}$ W	Prec $\frac{1}{2}\%$
R242	316-0101-00	B010100	B159999	100 Ω	$\frac{1}{4}$ W	
R242	316-0221-00	B160000		220 Ω	$\frac{1}{4}$ W	
R244	311-1116-00			100 Ω , Var		
R246	321-0053-00	B010100	B169999	34.8 Ω	$\frac{1}{8}$ W	Prec 1%
R246	321-0050-01	B170000		32.4 Ω	$\frac{1}{8}$ W	Prec $\frac{1}{2}\%$
R250	321-0175-00			649 Ω	$\frac{1}{8}$ W	Prec 1%
R252	321-0181-00			750 Ω	$\frac{1}{8}$ W	Prec 1%
R253	316-0270-00			27 Ω	$\frac{1}{4}$ W	
R255	316-0101-00			100 Ω	$\frac{1}{4}$ W	
R256	321-0232-00			2.55 k Ω	$\frac{1}{8}$ W	Prec 1%
R258	321-0255-00			4.42 k Ω	$\frac{1}{8}$ W	Prec 1%
R260	321-0175-00			649 Ω	$\frac{1}{8}$ W	Prec 1%
R262	321-0181-00			750 Ω	$\frac{1}{8}$ W	Prec 1%
R265	316-0101-00			100 Ω	$\frac{1}{4}$ W	
R270	316-0104-00			100 k Ω	$\frac{1}{4}$ W	
R273	321-0256-00			4.53 k Ω	$\frac{1}{8}$ W	Prec 1%
R274	311-1198-00			20 k Ω , Var		

¹R217 replaced with dummy resistor 131-0566-00 S/N B180000 and up. See Mechanical Parts List.

²Added if necessary.

A2 VERTICAL Circuit Board Assembly (cont)

Ckt. No.	Tektronix Part No.	Serial/Model No. Eff	Disc	Description			
Resistors (cont)							
R275	321-0207-00			1.4 k Ω	1/8 W	Prec	1%
R276	321-0177-00			681 Ω	1/8 W	Prec	1%
R277	321-0177-00			681 Ω	1/8 W	Prec	1%
R278	321-0226-00	B010100	B029999	2.21 k Ω	1/8 W	Prec	1%
R278	321-0182-00	B030000		768 Ω	1/8 W	Prec	1%
R279	321-0226-00	B010100	B029999	2.21 k Ω	1/8 W	Prec	1%
R279	321-0182-00	B030000		768 Ω	1/8 W	Prec	1%
R280	316-0104-00			100 k Ω	1/4 W		
R281	315-0302-00			3 k Ω	1/4 W		5%
R282	316-0152-00			1.5 k Ω	1/4 W		
R283	321-0256-00			4.53 k Ω	1/8 W	Prec	1%
R284	311-1198-00			20 k Ω , Var			
R285	321-0242-00			3.24 k Ω	1/8 W	Prec	1%
R286	315-0202-00			2 k Ω	1/4 W		5%
R287	321-0230-00			2.43 k Ω	1/8 W	Prec	1%
R288	321-0230-00			2.43 k Ω	1/8 W	Prec	1%
R289	321-0301-00			13.3 k Ω	1/8 W	Prec	1%
R300	316-0274-00			270 k Ω	1/4 W		
R302	316-0682-00			6.8 k Ω	1/4 W		
R304	316-0152-00			1.5 k Ω	1/4 W		
R310	316-0103-00			10 k Ω	1/4 W		
R312	311-1232-00			50 k Ω , Var			
R314	316-0103-00			10 k Ω	1/4 W		
R316	321-0104-00			118 Ω	1/8 W	Prec	1%
R317 ¹	315-0160-00	B010100	B179999X	16 Ω	1/4 W		5%
R319 ²	315-0104-00	XB020000		10 k Ω	1/4 W		5%
R320	321-0907-02	B010100	B019999	98 Ω	(nominal value)	Selected	
R320	321-0094-00	B020000	B209999	93.1 Ω	(nominal value)	Selected	
R320	321-0093-00	B210000	B211809	90.9 Ω	(nominal value)	Selected	
R320	321-0094-00	B211810		93.1 Ω	(nominal value)	Selected	
R321	315-0241-00			240 Ω	1/4 W		5%
R322 ²	315-0183-00	XB020000		18 k Ω	1/4 W		5%
R323	321-0131-00	B010100	B019999	226 Ω	1/8 W	Prec	1%
R323	321-0131-00	B020000	B209999	226 Ω	(nominal value)	Selected	
R323	321-0129-00	B210000	B211809	215 Ω	(nominal value)	Selected	
R323	321-0130-00	B211810		221 Ω	(nominal value)	Selected	
R324	315-0331-00			330 Ω	1/4 W		5%
R325	321-0172-00			604 Ω	1/8 W	Prec	1%
R326	321-0221-00			1.96 k Ω	1/8 W	Prec	1%
R328	321-0317-00			19.6 k Ω	1/8 W	Prec	1%
R329	321-0120-00			174 Ω	1/8 W	Prec	1%
R330	321-0172-00			604 Ω	1/8 W	Prec	1%
R331	315-0911-00			910 Ω	1/4 W		5%
R332	321-0204-00			1.3 k Ω	1/8 W	Prec	1%
R335	321-0202-00			1.24 k Ω	1/8 W	Prec	1%
R336	321-0172-00			604 Ω	1/8 W	Prec	1%
R338	321-0204-00			1.3 k Ω	1/8 W	Prec	1%
R340	321-0053-00	B010100	B169999	34.8 Ω	1/8 W	Prec	1%
R340	321-0050-01	B170000		32.4 Ω	1/8 W	Prec	1/2%
R342	316-0101-00	B010100	B159999	100 Ω	1/4 W		

¹R317 replaced with dummy resistor 131-0566-00 S/N B180000 and up. See Mechanical Parts List.

²Added if necessary.

A2 VERTICAL Circuit Board Assembly (cont)

Ckt. No.	Tektronix Part No.	Serial/Model No. Eff	Disc	Description		
Resistors (cont)						
R348	311-1035-00			50 k Ω , Var		
R349	316-0103-00			10 k Ω	1/4 W	
R350	321-0175-00			649 Ω	1/8 W	Prec
R352	321-0181-00			750 Ω	1/8 W	Prec
R353	316-0270-00			27 Ω	1/4 W	
R354	316-0152-00			1.5 k Ω	1/4 W	
R355	316-0101-00			100 Ω	1/4 W	
R356	321-0232-00			2.55 k Ω	1/8 W	Prec
R358	321-0255-00			4.42 k Ω	1/8 W	Prec
R360	321-0175-00			649 Ω	1/8 W	Prec
R362	321-0181-00			750 Ω	1/8 W	Prec
R365	316-0101-00			100 Ω	1/4 W	
R404	321-0273-00			6.81 k Ω	1/8 W	Prec
R408	321-0273-00			6.81 k Ω	1/8 W	Prec
R410	321-0273-00			6.81 k Ω	1/8 W	Prec
R414	321-0273-00			6.81 k Ω	1/8 W	Prec
R419	315-0622-00			6.2 k Ω	1/4 W	
R420	321-0193-00			1 k Ω	1/8 W	Prec
R421	321-0210-00			1.5 k Ω	1/8 W	Prec
R422	321-0231-00			2.49 k Ω	1/8 W	Prec
R423	321-0231-00			2.49 k Ω	1/8 W	Prec
R424	321-0210-00			1.5 k Ω	1/8 W	Prec
R425	321-0193-00			1 k Ω	1/8 W	Prec
R426	301-0152-00			1.5 k Ω	1/2 W	
R427	301-0152-00			1.5 k Ω	1/2 W	
R428	301-0152-00			1.5 k Ω	1/2 W	
R429	301-0152-00			1.5 k Ω	1/2 W	
R430	315-0203-00			20 k Ω	1/4 W	
R431	316-0104-00			100 k Ω	1/4 W	
R432	316-0183-00			18 k Ω	1/4 W	
R433	316-0104-00			100 k Ω	1/4 W	
R435	301-0102-00			1 k Ω	1/2 W	
R436	315-0273-00			27 k Ω	1/4 W	
R437	317-0100-00	B010100	B149999	10 Ω	1/8 W	
R437	315-0100-00	B150000		10 Ω	1/4 W	
R438	317-0100-00	B010100	B149999	10 Ω	1/8 W	
R438	315-0100-00	B150000		10 Ω	1/4 W	
R439	316-0101-00			100 Ω	1/4 W	
R440	315-0392-00			3.9 k Ω	1/4 W	
R442	316-0270-00			27 Ω	1/4 W	
R445	315-0302-00			3 k Ω	1/4 W	
R450	321-0263-00			5.36 k Ω	1/8 W	Prec

A2 VERTICAL Circuit Board Assembly (cont)

Ckt. No.	Tektronix Part No.	Serial/Model No. Eff	Disc	Description		
Resistors (cont)						
R452	321-0263-00			5.36 k Ω	1/8 W	Prec 1%
R453	316-0101-00			100 Ω	1/4 W	
R454	321-0208-00			1.43 k Ω	1/8 W	Prec 1%
R455	321-0218-00			1.82 k Ω	1/8 W	Prec 1%
R456	321-0164-00			499 Ω	1/8 W	Prec 1%
R457	321-0164-00			499 Ω	1/8 W	Prec 1%
R458	321-0088-00			80.6 Ω	1/8 W	Prec 1%
R460	321-0314-00			18.2 k Ω	1/8 W	Prec 1%
R461	311-1227-00			5 k Ω , Var		
R463	315-0473-00			47 k Ω	1/4 W	5%
R465	323-0155-00			402 Ω	1/2 W	Prec 1%
R466	316-0101-00			100 Ω	1/4 W	
R470	321-0228-00			2.32 k Ω	1/8 W	Prec 1%
R471	321-0202-00			1.24 k Ω	1/8 W	Prec 1%
R472	321-0164-00			499 Ω	1/8 W	Prec 1%
R474	321-0164-00			499 Ω	1/8 W	Prec 1%
R476	321-0088-00			80.6 Ω	1/8 W	Prec 1%
R500	321-0092-00			88.7 Ω	1/8 W	Prec 1%
R505	316-0270-00			27 Ω	1/4 W	
R508	321-0179-00			715 Ω	1/8 W	Prec 1%
R510	321-0074-00			57.6 Ω	1/8 W	Prec 1%
R512	316-0820-00			82 Ω	1/4 W	
R515	315-0680-00			68 Ω	1/4 W	5%
R516	316-0470-00			47 Ω	1/4 W	
R518	321-0117-00			162 Ω	1/8 W	Prec 1%
R519	317-0101-00	B010100	B149999	100 Ω	1/8 W	5%
R519	315-0101-00	B150000		100 Ω	1/4 W	5%
R520	317-0101-00	B010100	B149999	100 Ω	1/8 W	5%
R520	315-0101-00	B150000		100 Ω	1/4 W	5%
R521	321-0178-00			698 Ω	1/8 W	Prec 1%
R525	323-0095-00			95.3 Ω	1/2 W	Prec 1%
R526	315-0512-00			5.1 k Ω	1/4 W	5%
R540	321-0092-00			88.7 Ω	1/8 W	Prec 1%
R545	316-0270-00			27 Ω	1/4 W	
R548	321-0179-00			715 Ω	1/8 W	Prec 1%
R549	317-0101-00	B010100	B149999	100 Ω	1/8 W	5%
R549	315-0101-00	B150000		100 Ω	1/4 W	5%
R550	317-0101-00	B010100	B149999	100 Ω	1/8 W	5%
R550	315-0101-00	B150000		100 Ω	1/4 W	5%
R551	321-0178-00			698 Ω	1/8 W	Prec 1%
R552	321-0117-00			162 Ω	1/8 W	Prec 1%
R553	316-0820-00			82 Ω	1/4 W	
R555	316-0470-00			47 Ω	1/4 W	
R565	323-0095-00			95.3 Ω	1/2 W	Prec 1%

Electrical Parts List—432/R432

A2 VERTICAL Circuit Board Assembly (cont)

Ckt. No.	Tektronix Part No.	Serial/Model No. Eff	No. Disc	Description		
Resistors (cont)						
R566	315-0512-00			5.1 k Ω	1/4 W	5%
R568	321-0060-00			41.2 Ω	1/8 W	1%
R570	321-0168-00	B010100	B149999	549 Ω	1/8 W	Prec 1%
R570	315-0221-00	B150000	B179999	220 Ω	1/4 W	Prec 1%
R570	311-0634-00	B180000		500 Ω , Var		5%
R571	315-0361-00			360 Ω	1/4 W	5%
R572	307-0124-00			5 k Ω	Thermal	
R574	321-0060-00			41.2 Ω	1/8 W	Prec 1%
R576	315-0301-00	B010100	B109999	300 Ω	1/4 W	5%
R576	316-0151-00	B110000		150 Ω	1/4 W	
R578	323-0075-00			59 Ω	1/2 W	Prec 1%
Switches						
Wired or Unwired						
S414	260-1236-00			Push-push		OUT-INVERT
S479	260-1236-00			Push-push		OUT 5 MHz BW
Transformer						
T435	*120-0459-00			Toroid, 10 turns, bifilar		
Integrated Circuits						
U210	*155-0050-00	B010100	B239999	Monolithic, differential pre-amplifier		
U210	*155-0050-01	B240000		Monolithic, differential pre-amplifier		
U310	*155-0050-00	B010100	B239999	Monolithic, differential pre-amplifier		
U310	*155-0050-01	B240000		Monolithic, differential pre-amplifier		

A3 VERTICAL MODE SWITCH Circuit Board Assembly

*670-1358-00

Complete Board

Capacitors

Tolerance $\pm 20\%$ unless otherwise indicated.

C8	*285-0816-02			0.019 μ F	PTM	600 V	10%
C9	281-0064-00			0.25-1.5 pF, Var	Plastic		
C18	*285-0816-02			0.019 μ F	PTM	600 V	10%
C19	281-0064-00			0.25-1.5 pF, Var	Plastic		
C45	283-0080-00			0.022 μ F	Cer	25 V	+80%—20%
C47	283-0080-00			0.022 μ F	Cer	25 V	+80%—20%

A3 VERTICAL MODE SWITCH Circuit Board Assembly (cont)

Ckt. No.	Tektronix Part No.	Serial/Model No. Eff	Disc	Description
----------	--------------------	----------------------	------	-------------

Resistors

Resistors are fixed, composition, $\pm 10\%$ unless otherwise indicated.

R8	316-0105-00		1 M Ω	1/4 W
R18	316-0105-00		1 M Ω	1/4 W

Switches

Wired or Unwired

S8 A } S8 B }	260-1227-00		Push-push	AC/DC
				GND
S18 A } S18 B }	260-1227-00		Push-push	AC/DC
				GND
S45 A-E	260-1230-00		Pushbutton	VERTICAL MODE

ATTENUATOR Circuit Board Assembly

A1	*672-0019-00	B010100	B179999	Complete Board
A2	*672-0019-01	B180000		includes:
A2	*670-1357-00			INPUT AMPLIFIER Circuit Board Assembly
A2	*670-1365-00	B010100	B029999	VERTICAL AMPLIFIER Circuit Board Assembly
A4	*670-1365-01	B030000	B179999	VERTICAL AMPLIFIER Circuit Board Assembly
A5	*670-1365-02	B180000		VERTICAL AMPLIFIER Circuit Board Assembly
				CAM SWITCH Assembly CH1
				CAM SWITCH Assembly CH2
	*670-1356-00	XB210000		ATTENUATOR Circuit Board Assembly

A4 CAM SWITCH ASSEMBLY CH1

Capacitors

Tolerance $\pm 20\%$ unless otherwise indicated.

C106	*307-1010-00	B010100	B189999	2 x Hybrid
C106	*307-1010-01	B190000		2 x Hybrid
C107	*307-1010-00	B010100	B189999	2 x Hybrid
C107	*307-1010-01	B190000		2 x Hybrid
C110	*307-1012-00			5 x Hybrid
C111	*307-1012-00			5 x Hybrid
C114	*307-1013-00			10 x Hybrid
C115	*307-1013-00			10 x Hybrid
C118	*307-1014-00	B010100	B189999	100 x Hybrid
C118	*307-1014-01	B190000		10 x Hybrid
C119	*307-1014-00	B010100	B189999	100 x Hybrid
C119	*307-1014-01	B190000		100 x Hybrid

Resistor

Resistors are fixed, composition, $\pm 10\%$ unless otherwise indicated.

R245	*311-1125-00			250 Ω , Var
------	--------------	--	--	--------------------

Electrical Parts List—432/R432

A4 CAM SWITCH ASSEMBLY CH1 (cont)

Ckt. No.	Tektronix Part No.	Serial/Model No. Eff	No. Disc	Description		
				Switch		
				Wired or Unwired		
S100 ¹	*105-0227-00	B010100	B209999	Cam	CH1	VOLTS/DIV
S100 ¹	*263-1020-00	B210000		Cam	CH1	VOLTS/DIV

A5 CAM SWITCH ASSEMBLY CH2

Capacitors

Tolerance $\pm 20\%$ unless otherwise indicated.

C106	*307-1010-00	B010100	B189999	2 x Hybrid		
C106	*307-1010-01	B180000		2 x Hybrid		
C107	*307-1010-00	B010100	B189999	2 x Hybrid		
C107	*307-1010-01	B190000		2 x Hybrid		
C110	*307-1012-00			5 x Hybrid		
C111	*307-1012-00			5 x Hybrid		
C114	*307-1013-00			10 x Hybrid		
C115	*307-1013-00			10 x Hybrid		
C118	*307-1014-00	B010100	B189999	100 x Hybrid		
C118	*307-1014-01	B190000		100 x Hybrid		
C119	*307-1014-00	B010100	B189999	100 x Hybrid		
C119	*307-1014-01	B190000		100 x Hybrid		

Resistor

Resistors are fixed, composition, $\pm 10\%$ unless otherwise indicated.

R345	*311-1125-00			250 Ω , Var		
------	--------------	--	--	--------------------	--	--

Switch

Wired or Unwired

S200 ¹	*105-0227-00	B010100	B209999	Cam	CH2	VOLTS/DIV
S200 ¹	*263-1020-00	B210000		Cam	CH2	VOLTS/DIV

A6 TRIGGER SOURCE SWITCH Circuit Board Assembly

*670-1364-00

Complete Board

Capacitors

Tolerance $\pm 20\%$ unless otherwise indicated.

C70	281-0500-00		2.2 pF	Cer	500 V	± 0.5 pF
C72	283-0023-00		0.1 μ F	Cer	10 V	
C73	283-0003-00		0.01 μ F	Cer	150 V	

¹See Mechanical Parts List for replacement parts.

A6 TRIGGER SOURCE SWITCH Circuit Board Assembly (cont)

Ckt. No.	Tektronix Part No.	Serial/Model No. Eff	No. Disc	Description		
----------	--------------------	----------------------	----------	-------------	--	--

Resistors

Resistors are fixed, composition, $\pm 10\%$ unless otherwise indicated.

R61	316-0104-00	XB100000		100 k Ω	1/4 W		
R70	322-0621-00			900 k Ω	1/4 W	Prec	1%
R71	321-0617-00			111 k Ω	1/8 W	Prec	1%
R72	316-0471-00			470 Ω	1/4 W		

Switches

Wired or Unwired

S70	260-1224-00			Push-push		EXT ATTEN	
S72 A } S72 B }	260-1228-00	B010100	B219999	Pushbutton		TRIGGER SOURCE	
S72 A } S72 B }	260-1228-01	B220000		Pushbutton		TRIGGER SOURCE	

A7 TRIGGER COUPLING SWITCH Circuit Board Assembly

*670-1363-00

Complete Board

Capacitors

Tolerance $\pm 20\%$ unless otherwise indicated.

C72	283-0006-00			0.02 μ F	Cer	500 V	
C74	283-0128-00			100 pF	Cer	500 V	5%
C76	281-0510-00			22 pF	Cer	500 V	

Resistors

Resistors are fixed, composition, $\pm 10\%$ unless otherwise indicated.

R74	315-0104-00			100 k Ω	1/4 W		5%
R76	315-0563-00	B010100	B129999	56 k Ω	1/4 W		5%
R76	315-0273-00	B130000		27 k Ω	1/4 W		5%

Switches

Wired or Unwired

S74	260-1224-00			Push-push		AC/DC (TRIGGER COUPLING)	
S75 A } S75 B }	260-1226-00			Push-push		LF REJ/HF REJ (TRIGGER COUPLING)	

Electrical Parts List—432/R432

A8 HORIZONTAL Circuit Board Assembly

Ckt. No.	Tektronix Part No.	Serial/Model No. Eff	No. Disc	Description
	*670-1359-02	B010100	B019999	Complete Board
	*670-1359-04	B020000	B049999	Complete Board
	*670-1359-08	B050000	B059999	Complete Board
	*670-1359-10	B060000		Complete Board

Capacitors					
Tolerance $\pm 20\%$ unless otherwise indicated.					
C602	283-0003-00			0.01 μF	Cer 150 V
C604	283-0003-00			0.01 μF	Cer 150 V
C605	283-0080-00			0.022 μF	Cer 25 V +80%—20%
C614	283-0003-00			0.01 μF	Cer 150 V
C622	283-0003-00			0.01 μF	Cer 150 V
C624	283-0081-00			0.1 μF	Cer 25 V +80%—20%
C645	283-0067-00			0.001 μF	Cer 200 V 10%
C648	283-0026-00			0.2 μF	Cer 25 V
C650	290-0527-00			15 μF	Elect. 20 V
C663	281-0562-00	B010100	B099999	39 pF	Cer 500 V
C663	281-0549-00	B100000		68 pF	Cer 500 V 10%
C670	281-0519-00			47 pF	Cer 500 V 10%
C686	281-0504-00			10 pF	Cer 500 V 10%
C688	283-0003-00			0.01 μF	Cer 150 V
C690	283-0003-00			0.01 μF	Cer 150 V
C692	281-0511-00			22 pF	Cer 500 V 10%
C700	281-0551-00			390 pF	Cer 500 V 10%
C701	281-0617-00			15 pF	Cer 200 V
C702	290-0136-00			2.2 μF	Elect. 20 V
C706	283-0067-00			0.001 μF	Cer 200 V 10%
C709	281-0651-00			47 pF	Cer 200 V 5%
C710 A } ¹	*295-0150-00			10 μF	Matched to 1%
C710 B }				0.1 μF	
C710 C }				0.001 μF	
C715	283-0599-00			98 pF	Mica 500 V 5%
C716	281-0123-00			5-25 pF, Var	Cer 100 V
C718	290-0246-00			3.3 μF	Elect. 15 V 10%
C720	290-0247-00			5.6 μF	Elect. 6 V
C722	290-0247-00			5.6 μF	Elect. 6 V
C730	283-0067-00			0.001 μF	Cer 200 V 10%
C732	283-0004-00			0.02 μF	Cer 150 V
C734	283-0059-00			1 μF	Cer 25 V +80%—20%
C742	283-0081-00			0.1 μF	Cer 25 V +80%—20%
C761	290-0527-00			15 μF	Elect. 20 V
C764	281-0519-00			47 pF	Cer 500 V 10%
C775	283-0003-00			0.01 μF	Cer 150 V

¹Individual timing capacitors in this assembly must be ordered by the 9 digit part number, letter suffix and tolerance printed on the timing capacitor to be replaced.

Example:

F—
285-XXXX-XX

The letter suffix and the tolerance should be the same for all of the timing capacitors in the assembly.

A8 HORIZONTAL Circuit Board Assembly (cont)

Ckt. No.	Tektronix Part No.	Serial/Model No. Eff	Disc	Description
Capacitors (cont)				
C780	281-0543-00			270 pF Cer 500 V 10%
C782	281-0519-00			47 pF Cer 500 V 10%
C784	283-0001-00			0.005 μ F Cer 500 V
C794	281-0562-00			39 pF Cer 500 V
C796	290-0267-00			1 μ F Elect. 35 V
C797	283-0004-00			0.02 μ F Cer 150 V
C798	290-0267-00			1 μ F Elect. 35 V
C801	290-0246-00			3.3 μ F Elect. 15 V 10%
C805	290-0246-00			3.3 μ F Elect. 15 V 10%
C812	283-0177-00			1 μ F Cer 25 V +80%—20%
C871	281-0064-00			0.25-1.5 pF, Var Plastic
C872	283-0001-00			0.005 μ F Cer 500 V
C874	283-0008-00			0.1 μ F Cer 500 V
C876	283-0002-00			0.01 μ F Cer 500 V
C881	281-0064-00			0.25-1.5 pF, Var Plastic
C882	283-0001-00			0.005 μ F Cer 500 V
C884	283-0008-00			0.1 μ F Cer 500 V
C886	283-0002-00			0.01 μ F Cer 500 V
C896	283-0017-00			1 μ F Cer 3 V
Semiconductor Device, Diodes				
CR603	152-0246-00			Silicon Low leakage 250 mW, 40 V
CR606	*152-0185-00			Silicon Replaceable by 1N4152
CR610	*152-0185-00			Silicon Replaceable by 1N4152
CR615	*152-0185-00			Silicon Replaceable by 1N4152
CR616	*152-0185-00			Silicon Replaceable by 1N4152
CR623	*152-0185-00			Silicon Replaceable by 1N4152
CR630	*152-0185-00			Silicon Replaceable by 1N4152
CR632	*152-0185-00			Silicon Replaceable by 1N4152
CR634	*152-0185-00			Silicon Replaceable by 1N4152
CR635	*152-0185-00			Silicon Replaceable by 1N4152
CR640	*152-0185-00			Silicon Replaceable by 1N4152
CR644	152-0093-00	B010100	B099999	Tunnel 1N3716 4.7 mA
CR644	*152-0125-00	B100000		Tunnel TD3A, 4.7 mA, Tek Spec
CR655	*152-0185-00			Silicon Replaceable by 1N4152
CR656	*152-0185-00			Silicon Replaceable by 1N4152
CR657	*152-0185-00			Silicon Replaceable by 1N4152
CR660	*152-0185-00			Silicon Replaceable by 1N4152
CR662	*152-0153-00			Silicon Tek Spec
CR678	152-0093-00	B010100	B099999	Tunnel 1N3716 4.7 mA
CR678	*152-0125-00	B020000		Tunnel TD3A, 4.7 mA, Tek Spec
CR688	*152-0185-00			Silicon Replaceable by 1N4152
CR707	*152-0153-00			Silicon Tek Spec

A8 HORIZONTAL Circuit Board Assembly (cont)

Ckt. No.	Tektronix Part No.	Serial/Model No. Eff	Disc		Description
Semiconductor Device, Diodes (cont)					
CR710	*152-0185-00			Silicon	Replaceable by 1N4152
CR765	*152-0185-00			Silicon	Replaceable by 1N4152
CR770	*152-0185-00			Silicon	Replaceable by 1N4152
CR785	*152-0185-00			Silicon	Replaceable by 1N4152
CR792	*152-0153-00			Silicon	Tek Spec
CR794	*152-0153-00			Silicon	Tek Spec
CR795	*152-0153-00			Silicon	Tek Spec
CR829	*152-0185-00			Silicon	Replaceable by 1N4152
CR835	*152-0185-00	B010100	B049999	Silicon	Replaceable by 1N4152
CR835	*152-0153-00	B050000		Silicon	Tek Spec
CR836	*152-0153-00			Silicon	Tek Spec
CR840	*152-0185-00			Silicon	Replaceable by 1N4152
CR859	*152-0185-00			Silicon	Replaceable by 1N4152
CR862	*152-0185-00			Silicon	Replaceable by 1N4152
CR864	*152-0185-00			Silicon	Replaceable by 1N4152
CR865	*152-0185-00	B010100	B049999	Silicon	Replaceable by 1N4152
CR865	*152-0153-00	B050000		Silicon	Tek Spec
CR866	*152-0153-00			Silicon	Tek Spec
CR870	*152-0153-00			Silicon	Tek Spec
CR880	*152-0153-00			Silicon	Tek Spec
CR896	*152-0185-00	B010100	B159999	Silicon	Replaceable by 1N4152
CR896	152-0141-02	B160000		Silicon	1N4152
CR898	*152-0185-00	B010100	B159999	Silicon	Replaceable by 1N4152
CR898	152-0141-02	B160000		Silicon	1N4152
VR605	152-0226-00			Zener	1N751A 400 mW, 5.1 V, 5%
VR635	152-0195-00			Zener	1N751A 400 mW, 5.1 V, 5%
VR657	152-0168-00			Zener	1N963A 400 mW, 12 V, 5%
VR741	152-0168-00			Zener	1N963A 400 mW, 12 V, 5%
VR872	152-0306-00			Zener	1N960B 400 mW, 9.1 V, 5%
VR876	152-0304-00			Zener	1N968B 400 mW, 20 V, 5%
Transistors					
Q605 A,B	*151-1049-00	B010100	B019999	Silicon	JFET TO-71 N channel, dual, Tek Spec
Q605 A,B	151-1041-00	B020000		Silicon	FET TO-71 N channel junction
Q610	*151-0190-01			Silicon	NPN TO-106 Tek Spec
Q618	*151-0190-01			Silicon	NPN TO-106 Tek Spec
Q635	151-0220-00			Silicon	PNP TO-18 2N4122
Q645	151-0220-00			Silicon	PNP TO-18 2N4122
Q660	151-0220-00			Silicon	PNP TO-18 2N4122
Q665	151-0250-00			Silicon	NPN TO-104 2N5184
Q818	*151-0216-00			Silicon	PNP TO-92 Replaceable by MOT MPS 6523
Q825 A,B	*151-0261-00			Silicon	PNP TO-78 Tek Spec, dual
Q830 A,B	*151-0232-00			Silicon	NPN TO-78 Tek Spec, dual

A8 HORIZONTAL Circuit Board Assembly (cont)

Ckt. No.	Tektronix Part No.	Serial/Model No. Eff	Disc	Description
Transistors (cont)				
Q835 A,B	*151-0232-00		Silicon	NPN TO-78 Tek Spec, dual
Q836 A,B	*151-0261-00		Silicon	PNP TO-78 Tek Spec
Q861	*151-0192-00		Silicon	NPN TO-92 Replaceable by MPS 6521
Q870	*151-0192-00		Silicon	NPN TO-92 Replaceable by MPS 6521
Q874	151-0280-00		Silicon	PNP TO-5 MM4003
Q877	151-0279-00		Silicon	NPN TO-39 SE 7056
Q880	151-0164-00		Silicon	PNP TO-5 2N5447
Q884	151-0280-00		Silicon	PNP TO-5 MM4003
Q887	151-0279-00		Silicon	NPN TO-39 SE 7056
Q895	*151-0192-00		Silicon	NPN TO-92 Replaceable by MPS 6521

Resistors

Resistors are fixed, composition, $\pm 10\%$ unless otherwise indicated.

R600	322-0481-00	1 M Ω	1/4 W	Prec	1%
R602	316-0154-00	150 k Ω	1/4 W		
R603	316-0101-00	100 Ω	1/4 W		
R604	316-0151-00	150 Ω	1/4 W		
R605	321-0164-00	499 Ω	1/8 W	Prec	1%
R606	316-0470-00	47 Ω	1/4 W		
R608	316-0101-00	100 Ω	1/4 W		
R610	316-0470-00	47 Ω	1/4 W		
R612	315-0182-00	1.8 k Ω	1/4 W		5%
R613	321-0164-00	499 Ω	1/8 W	Prec	1%
R614	316-0151-00	150 Ω	1/4 W		
R615	315-0332-00	3.3 k Ω	1/4 W		5%
R616	315-0911-00	910 Ω	1/4 W		5%
R618	321-0164-00	499 Ω	1/8 W	Prec	1%
R620	321-0290-00	10.2 k Ω	1/8 W	Prec	1%
R622	321-0258-00	4.75 k Ω	1/8 W	Prec	1%
R623	315-0431-00	430 Ω	1/4 W		5%
R624	316-0101-00	100 Ω	1/4 W		
R625	315-0751-00	750 Ω	1/4 W		5%
R626	315-0112-00	1.1 k Ω	1/4 W		5%
R628	316-0392-00	3.9 k Ω	1/4 W		
R629	311-0644-00	20 k Ω , Var			
R634	316-0222-00	2.2 k Ω	1/4 W		
R635	316-0222-00	2.2 k Ω	1/4 W		
R636	301-0391-00	390 Ω	1/2 W		5%

A8 HORIZONTAL Circuit Board Assembly (cont)

Ckt. No.	Tektronix Part No.	Serial/Model No. Eff	Disc	Description		
Resistors (cont)						
R637	316-0272-00			2.7 k Ω	1/4 W	
R638	316-0222-00			2.2 k Ω	1/4 W	
R640	315-0472-00	B010100	B099999	4.7 k Ω	1/4 W	5%
R640	316-0392-00	B100000		3.9 k Ω	1/4 W	5%
R644	315-0560-00			56 Ω	1/4 W	5%
R645	315-0472-00			4.7 k Ω	1/4 W	5%
R646	315-0300-00			30 Ω	1/4 W	5%
R650	316-0101-00			100 Ω	1/4 W	
R651	315-0513-00			51 k Ω	1/4 W	5%
R652	315-0112-00			1.1 k Ω	1/4 W	5%
R654	321-0085-00			75 Ω	1/8 W	Prec 1%
R655	316-0101-00			100 Ω	1/4 W	
R656	321-0278-00			7.68 k Ω	1/8 W	Prec 1%
R657	315-0151-00			150 Ω	1/4 W	5%
R660	316-0153-00			15 k Ω	1/4 W	
R662	316-0392-00			3.9 k Ω	1/4 W	
R663	315-0101-00			100 Ω	1/4 W	5%
R665	316-0104-00			100 k Ω	1/4 W	
R666	316-0153-00			15 k Ω	1/4 W	
R667	321-0332-00			28 k Ω	1/8 W	Prec 1%
R668	321-0303-00			14 k Ω	1/8 W	Prec 1%
R669	321-0347-00			40.2 k Ω	1/8 W	Prec 1%
R670	321-0291-00			10.5 k Ω	1/8 W	Prec 1%
R672	321-0332-00			28 k Ω	1/8 W	Prec 1%
R675	321-0247-00	B010100	B019999	3.65 k Ω	1/8 W	Prec 1%
R675	321-0238-00	B020000	B049999	2.94 k Ω	1/8 W	Prec 1%
R675	321-0247-00	B050000		3.65 k Ω	1/8 W	Prec 1%
R678	321-0162-00			475 Ω	1/8 W	Prec 1%
R680	316-0101-00			100 Ω	1/4 W	
R682	321-0245-00			3.48 k Ω	1/8 W	Prec 1%
R684	321-0270-00			6.34 k Ω	1/8 W	Prec 1%
R685	321-0085-00			75 Ω	1/8 W	Prec 1%
R686	321-0164-00			499 Ω	1/8 W	Prec 1%
R687	321-0262-00			5.23 k Ω	1/8 W	Prec 1%
R688	316-0101-00			100 Ω	1/4 W	
R690	316-0101-00			100 Ω	1/4 W	
R692	321-0232-00			2.55 k Ω	1/8 W	Prec 1%
R700	316-0102-00			1 k Ω	1/4 W	
R701	316-0104-00			100 k Ω	1/4 W	
R702	316-0101-00			100 Ω	1/4 W	
R703	311-0644-00			20 k Ω , Var		
R704	316-0223-00			22 k Ω	1/4 W	
R705	321-0287-00			9.53 k Ω	1/8 W	Prec 1%

A8 HORIZONTAL Circuit Board Assembly (cont)

Ckt. No.	Tektronix Part No.	Serial/Model No. Eff	Disc	Description		
Resistors (cont)						
R706	321-0264-00		5.49 kΩ	1/8 W	Prec	1%
R707	316-0101-00		100 Ω	1/4 W		
R708	316-0561-00		560 Ω	1/4 W		
R709	316-0101-00		100 Ω	1/4 W		
R710	316-0220-00		22 Ω	1/4 W		
R711	315-0110-00		11 Ω	1/4 W		5%
R712	321-0934-00		19.19 kΩ	1/8 W	Prec	1/2%
R714	321-0418-02		221 kΩ	1/8 W	Prec	1/2%
R715	322-0510-02		2 MΩ	1/4 W	Prec	1/2%
R718	321-0154-00		392 Ω	1/8 W	Prec	1%
R719	321-0249-00		3.83 kΩ	1/8 W	Prec	1%
R720	321-0149-00		348 Ω	1/8 W	Prec	1%
R722	321-0175-00		649 Ω	1/8 W	Prec	1%
R723	321-0155-02		402 Ω	1/8 W	Prec	1/2%
R724	321-0228-00		2.32 kΩ	1/8 W	Prec	1%
R725	321-0172-02		604 Ω	1/8 W	Prec	1/2%
R726	321-0193-02		1 kΩ	1/8 W	Prec	1/2%
R727	311-0607-00		10 kΩ, Var			
R728	321-0193-00		1 kΩ	1/8 W	Prec	1%
R729	316-0123-00		12 kΩ	1/4 W		
R740	321-0209-00		1.47 kΩ	1/8 W	Prec	1%
R741	316-0151-00		150 Ω	1/4 W		
R742	316-0470-00		47 Ω	1/4 W		
R744	315-0102-00		1 kΩ	1/4 W		5%
R745	315-0332-00		3.3 kΩ	1/4 W		5%
R746	321-0300-00		13 kΩ	1/8 W	Prec	1%
R747	315-0682-00	XB050000	6.8 kΩ	1/4 W		5%
R748	315-0512-00		5.1 kΩ	1/4 W		5%
R752	315-0113-00		11 kΩ	1/4 W		5%
R754	315-0392-00		3.9 kΩ	1/4 W		5%
R756	315-0242-00		2.4 kΩ	1/4 W		5%
R760	321-0222-00		2 kΩ	1/8 W	Prec	1%
R761	321-0114-00		150 Ω	1/8 W	Prec	1%
R762	321-0362-00		57.6 kΩ	1/8 W	Prec	1%
R763	321-0191-00		953 Ω	1/8 W	Prec	1%
R764	321-0280-00		8.06 kΩ	1/8 W	Prec	1%
R765	321-0292-00		10.7 kΩ	1/8 W	Prec	1%
R766	321-0247-00		3.65 kΩ	1/8 W	Prec	1%
R768	321-0280-00		8.06 kΩ	1/8 W	Prec	1%
R770	316-0183-00		18 kΩ	1/4 W		
R772	321-0284-00		8.87 kΩ	1/8 W	Prec	1%

A8 HORIZONTAL Circuit Board Assembly (cont)

Ckt. No.	Tektronix Part No.	Serial/Model No. Eff	Disc	Description		
Resistors (cont)						
R774	321-0268-00			6.04 kΩ	1/8 W	Prec
R775	316-0101-00			100 Ω	1/4 W	1%
R778	316-0204-00			200 kΩ	1/4 W	
R780	315-0103-00			10 kΩ	1/4 W	
R782	316-0336-00			33 MΩ	1/4 W	5%
R783	316-0220-00			22 Ω	1/4 W	
R784	316-0102-00			1 kΩ	1/4 W	
R785	321-0193-00			1 kΩ	1/8 W	Prec
R786	321-0303-00			14 kΩ	1/8 W	Prec
R790	315-0820-00			82 Ω	1/4 W	5%
R791	315-0392-00			3.9 kΩ	1/4 W	5%
R792	321-0277-00			7.5 kΩ	1/8 W	Prec
R794	321-0222-00			2 kΩ	1/8 W	Prec
R795	321-0277-00	B010100	B059999	7.5 kΩ	1/8 W	Prec
R795	321-0269-00	B060000		6.19 kΩ	1/8 W	Prec
R796	321-0302-00			13.7 kΩ	1/8 W	Prec
R799	311-1126-00			10 kΩ, Var		
R801	315-0162-00			1.6 kΩ	1/4 W	5%
R803	321-0255-00			4.42 kΩ	1/8 W	Prec
R804	321-0364-00			60.4 kΩ	1/8 W	Prec
R805	315-0332-00			3.3 kΩ	1/4 W	5%
R807	321-0290-00			10.2 kΩ	1/8 W	Prec
R808	321-0364-00			60.4 kΩ	1/8 W	Prec
R809	321-0449-00			464 kΩ	1/8 W	Prec
R810	321-0336-00			30.9 kΩ	1/8 W	Prec
R812	321-0259-00			4.87 kΩ	1/8 W	Prec
R814	321-0208-00			1.43 kΩ	1/8 W	Prec
R815	321-0214-00			1.65 kΩ	1/8 W	Prec
R816	321-0225-00			2.15 kΩ	1/8 W	Prec
R817	311-0644-00			20 kΩ, Var		
R818	321-0155-00			402 Ω	1/8 W	Prec
R819	321-0296-00			11.8 kΩ	1/8 W	Prec
R825	321-0214-00			1.65 kΩ	1/8 W	Prec
R826	321-0225-00			2.15 kΩ	1/8 W	Prec
R827	321-0286-00			9.31 kΩ	1/8 W	Prec
R829	321-0222-00			2 kΩ	1/8 W	Prec
R830	316-0470-00			47 Ω	1/4 W	
R832	316-0472-00			4.7 kΩ	1/4 W	
R835	321-0292-00			10.7 kΩ	1/8 W	Prec
R836	321-0247-00			3.65 kΩ	1/8 W	Prec
R838	321-0204-00			1.3 kΩ	1/8 W	Prec
R839	321-0029-00			19.6 Ω	1/8 W	Prec

A8 HORIZONTAL Circuit Board Assembly (cont)

Ckt. No.	Tektronix Part No.	Serial/Model No. Eff	Disc	Description			
Resistors (cont)							
R840	321-0193-07			1 kΩ	1/8 W	Prec	1/10%
R841	321-0175-00			649 Ω	1/8 W	Prec	1%
R842	321-0161-00			464 Ω	1/8 W	Prec	1%
R843	316-0473-00	XB160000		47 kΩ	1/4 W		
R844	321-0117-00	B010100	B159999	162 Ω	1/8 W	Prec	1%
R844	321-0118-00	B160000		165 Ω	1/8 W	Prec	1%
R846	321-0122-00			182 Ω	1/8 W	Prec	1%
R848	321-0061-00			42.2 Ω	1/8 W	Prec	1%
R850	321-0034-00			22.1 Ω	1/8 W	Prec	1%
R852	321-0003-00			10.5 Ω	1/8 W	Prec	1%
R858	321-0029-00			19.6 Ω	1/8 W	Prec	1%
R859	321-0193-07			1 kΩ	1/8 W	Prec	1/10%
R860	316-0470-00			47 Ω	1/4 W		
R861	321-0111-00	B010100	B049999	140 Ω	1/8 W	Prec	1%
R861	321-0113-00	B050000		147 Ω	1/8 W	Prec	1%
R862	321-0186-00			845 Ω	1/8 W	Prec	1%
R863	321-0273-00			6.81 kΩ	1/8 W	Prec	1%
R864	315-0302-00			3 kΩ	1/4 W		5%
R865	321-0292-00			10.7 kΩ	1/8 W	Prec	1%
R866	321-0247-00			3.65 kΩ	1/8 W	Prec	1%
R867	316-0472-00			4.7 kΩ	1/4 W		
R868	311-0635-00			1 kΩ, Var			
R870	323-0139-00			274 Ω	1/2 W	Prec	1%
R871	324-0356-00	B010100	B059999	49.9 kΩ	1 W	Prec	1%
R871	323-0327-00	B060000		24.9 kΩ	1/2 W	Prec	1%
R872	323-0327-00	XB060000		24.9 kΩ	1/2 W	Prec	1%
R874	303-0563-00			56 kΩ	1 W		5%
R875	321-0244-00			3.4 kΩ	1/8 W	Prec	1%
R876	316-0471-00			470 Ω	1/4 W		
R877	323-0188-00			887 Ω	1/2 W	Prec	1%
R879	316-0101-00			100 Ω	1/4 W		
R880	323-0327-00	XB060000		24.9 kΩ	1/2 W	Prec	1%
R881	324-0356-00	B010100	B059999	49.9 kΩ	1 W	Prec	1%
R881	323-0327-00	B060000		24.9 kΩ	1/2 W	Prec	1%
R882	321-0143-00			301 Ω	1/8 W	Prec	1%
R884	303-0563-00			56 kΩ	1 W		5%
R885	321-0244-00			3.4 kΩ	1/8 W	Prec	1%
R886	316-0471-00			470 Ω	1/4 W		
R887	323-0188-00			887 Ω	1/2 W	Prec	1%
R888	316-0104-00			100 kΩ	1/4 W		
R889	316-0101-00			100 Ω	1/4 W		
R890	321-0256-00			4.53 kΩ	1/8 W	Prec	1%
R892	321-0236-00			2.8 kΩ	1/8 W	Prec	1%
R896	323-0118-00			165 Ω	1/2 W	Prec	1%
R898	323-0148-00			340 Ω	1/2 W	Prec	1%

Electrical Parts List—432/R432

A8 HORIZONTAL Circuit Board Assembly (cont)

Ckt. No.	Tektronix Part No.	Serial/Model No. Eff	No. Disc	Description	
Switch					
	Wired or Unwired				
S700 ¹	*105-0262-00	B010100	B049999	Cam	TIME/DIV
S700 ¹	*105-0262-01	B050000		Cam	TIME/DIV

Transformer

T645	*120-0724-00			Toroid, 2 windings
------	--------------	--	--	--------------------

Integrated Circuits

U650	156-0048-00			Linear, replaceable by CA3046
U680	156-0048-00			Linear, replaceable by CA3046
U700	*155-0028-01			Miller integrator
U760	156-0048-00			Linear, replaceable by CA3046

A9 PRIMARY POWER SUPPLY Circuit Board Assembly

*670-1350-00

Complete Board

Capacitors

Tolerance $\pm 20\%$ unless otherwise indicated.

C1020	290-0164-00		1 μ F	Elect.	150 V	
C1024	283-0203-00		0.47 μ F	Cer	50 V	
C1030	290-0420-00	XB250000	0.68 μ F	Elect.	75 V	
C1034	290-0194-00		10 μ F	Elect.	100 V	
C1036	283-0002-00		0.01 μ F	Cer	500 V	
C1038	283-0002-00		0.01 μ F	Cer	500 V	
C1044	281-0523-00		100 pF	Cer	350 V	
C1046	283-0646-00		170 pF	Mica	100 V	1%
C1062	285-0598-00	XB250000	0.01 μ F	Plastic	100 V	5%
C1071	283-0142-00		0.0027 μ F	Cer	200 V	5%
C1076	283-0142-00		0.0027 μ F	Cer	200 V	5%
C1081	281-0536-00		1000 pF	Cer	500 V	10%
C1090	281-0546-00		330 pF	Cer	500 V	10%
C1093	281-0543-00		270 pF	Cer	500 V	10%
C1095	290-0167-00		10 μ F	Elect.	15 V	

¹See Mechanical Parts List for replacement parts.

A9 PRIMARY POWER SUPPLY Circuit Board Assembly (cont)

Ckt. No.	Tektronix Part No.	Serial/Model No. Eff	Disc	Description
Semiconductor Device, Diodes				
CR1032	*152-0061-00		Silicon	Tek Spec
CR1040	*152-0185-00		Silicon	Replaceable by 1N4152
CR1056	*152-0185-00		Silicon	Replaceable by 1N4152
CR1058	*152-0185-00		Silicon	Replaceable by 1N4152
CR1060	*152-0185-00		Silicon	Replaceable by 1N4152
CR1065	*152-0185-00		Silicon	Replaceable by 1N4152
CR1066	152-0333-00		Silicon	High speed and conductance
CR1068	152-0333-00		Silicon	High speed and conductance
CR1070	*152-0185-00		Silicon	Replaceable by 1N4152
CR1071	*152-0185-00		Silicon	Replaceable by 1N4152
CR1075	*152-0061-00		Silicon	Tek Spec
CR1077	*152-0185-00		Silicon	Replaceable by 1N4152
CR1078	152-0333-00		Silicon	High speed and conductance
CR1079	152-0333-00		Silicon	High speed and conductance
CR1080	152-0333-00		Silicon	High speed and conductance
CR1081	*152-0185-00		Silicon	Replaceable by 1N4152
CR1082	*152-0185-00		Silicon	Replaceable by 1N4152
CR1085	*152-0061-00		Silicon	Tek Spec
CR1090	*152-0185-00		Silicon	Replaceable by 1N4152
CR1091	*152-0185-00		Silicon	Replaceable by 1N4152
CR1092	*152-0061-00		Silicon	Tek Spec
CR1093	*152-0185-00		Silicon	Replaceable by 1N4152
CR1094	152-0333-00		Silicon	High speed and conductance
CR1095	152-0333-00		Silicon	High speed and conductance
CR1096	152-0333-00		Silicon	High speed and conductance
CR1097	152-0333-00		Silicon	High speed and conductance
CR1098	152-0333-00		Silicon	High speed and conductance
CR1099	152-0333-00		Silicon	High speed and conductance
VR1020	152-0427-00		Zener	1N985B 400 mW, 100 V, 5%
VR1025	152-0255-00		Zener	1N971B 400 mW, 51 V, 5%
VR1047	152-0283-00		Zener	1N976B 400 mW, 43 V, 5%
VR1052	152-0282-00		Zener	1N972B 400 mW, 30 V, 5%
VR1061	152-0280-00		Zener	1N753A 400 mW, 6.2 V, 5%
VR1072	152-0304-00		Zener	1N968B 400 mW, 20 V, 5%
VR1080	152-0279-00		Zener	1N751A 400 mW, 5.1 V, 5%
VR1094	152-0255-00		Zener	1N978B 400 mW, 51 V, 5%
Bulbs				
DS1020	150-0035-00		Neon, A1D-T, 0.3 mA	
DS1024	150-0035-00		Neon, A1D-T, 0.3 mA	

Electrical Parts List—432/R432

A9 PRIMARY POWER SUPPLY Circuit Board Assembly (cont)

Ckt. No.	Tektronix Part No.	Serial/Model No. Eff	No. Disc		Description
Transistors					
Q1025	151-0250-00			Silicon	NPN TO-104 2N5184
Q1030	*151-0297-00			Silicon	NPN TO-39 High voltage, Tek Spec
Q1032	*151-0297-00			Silicon	NPN TO-39 High voltage, Tek Spec
Q1040	*151-0228-00			Silicon	PNP TO-5 Tek Spec
Q1045	*151-0228-00			Silicon	PNP TO-5 Tek Spec
Q1050	151-0508-00			Silicon	PNPN TO-98 D13T1
Q1064	151-0279-00	B010100	B219999	Silicon	NPN TO-39 SE 7056
Q1064	151-0169-00	B220000		Silicon	NPN TO-5 2N3439
Q1065	151-0164-00			Silicon	PNP TO-5 2N5447
Q1075	151-0508-00			Silicon	PNPN TO-98 D13T1
Q1078	151-0290-00	B010100	B139999	Silicon	NPN TO-5 2N4895
Q1078	151-0200-00	B140000		Silicon	NPN TO-5 2N3499
Q1090	151-0188-00			Silicon	PNP TO-92 2N3906
Q1091	151-0302-00			Silicon	NPN TO-18 2N2222A
Q1094	151-0290-00	B010100	B139999	Silicon	NPN TO-5 2N4895
Q1094	151-0124-00	B140000		Silicon	NPN TO-5 2N3119

ResistorsResistors are fixed, composition, $\pm 10\%$ unless otherwise indicated.

R1020	316-0226-00			22 M Ω	$\frac{1}{4}$ W	
R1022	316-0474-00			470 k Ω	$\frac{1}{4}$ W	
R1024	316-0225-00			2.2 k Ω	$\frac{1}{4}$ W	
R1025	316-0104-00			100 k Ω	$\frac{1}{4}$ W	
R1026	316-0101-00			100 Ω	$\frac{1}{4}$ W	
R1028	316-0105-00			1 M Ω	$\frac{1}{4}$ W	
R1030	316-0393-00			39 k Ω	$\frac{1}{4}$ W	
R1032	306-0182-00			1.8 k Ω	2 W	
R1034	303-0103-00			10 k Ω	1 W	
R1036	316-0101-00	B010100	B019999	100 Ω	$\frac{1}{4}$ W	5%
R1036	316-0221-00	B020000		220 Ω	$\frac{1}{4}$ W	
R1038	316-0154-00	XB020000		150 k Ω	$\frac{1}{4}$ W	
R1040	316-0102-00			1 k Ω	$\frac{1}{4}$ W	
R1042	316-0102-00			1 k Ω	$\frac{1}{4}$ W	
R1044	316-0103-00			10 k Ω	$\frac{1}{4}$ W	
R1045	316-0104-00			100 k Ω	$\frac{1}{4}$ W	
R1046	316-0684-00			680 k Ω	$\frac{1}{4}$ W	
R1047	316-0103-00			10 k Ω	$\frac{1}{4}$ W	
R1050	316-0102-00			1 k Ω	$\frac{1}{4}$ W	
R1052	316-0102-00			1 k Ω	$\frac{1}{4}$ W	
R1054	316-0103-00			10 k Ω	$\frac{1}{4}$ W	
R1060	316-0391-00			390 Ω	$\frac{1}{4}$ W	
R1061	316-0102-00	B010100	B219999	1 k Ω	$\frac{1}{4}$ W	
R1061	315-0122-00	B220000		1.2 k Ω	$\frac{1}{4}$ W	5%
R1062	316-0222-00			2.2 k Ω	$\frac{1}{4}$ W	
R1064	316-0103-00	B010100	B159999	10 k Ω	$\frac{1}{4}$ W	
R1064	302-0103-00	B160000		10 k Ω	$\frac{1}{2}$ W	
R1065	316-0151-00			150 Ω	$\frac{1}{4}$ W	
R1068	307-0114-00			6.2 Ω	$\frac{1}{4}$ W	5%

A9 PRIMARY POWER SUPPLY Circuit Board Assembly (cont)

Ckt. No.	Tektronix Part No.	Serial/Model No. Eff	No. Disc	Description
Resistors (cont)				
R1071	316-0331-00			330 Ω 1/4 W
R1072	316-0153-00			15 k Ω 1/4 W
R1074	311-0609-00			2 k Ω , Var
R1075	316-0681-00			680 Ω 1/4 W
R1076	316-0102-00			1 k Ω 1/4 W
R1077	316-0182-00			1.8 k Ω 1/4 W
R1078	316-0472-00			4.7 k Ω 1/4 W
R1080	316-0102-00			1 k Ω 1/4 W
R1081	316-0101-00			100 Ω 1/4 W
R1090	316-0472-00			4.7 k Ω 1/4 W
R1091	316-0221-00			220 Ω 1/4 W
R1092	316-0102-00			1 k Ω 1/4 W
R1093	316-0273-00			27 k Ω 1/4 W
R1094	316-0101-00			100 Ω 1/4 W
R1095	316-0222-00			2.2 k Ω 1/4 W

Transformers

T1036	*120-0722-00			Toroid, 5 turns, bifilar
T1064	*120-0718-00	B010100	B159999	Pot core
T1064	*120-0718-01	B160000		Pot core
T1078	*120-0720-00			Pot core
T1080	*120-0717-00			Pot core

A10 SECONDARY POWER SUPPLY Circuit Board Assembly

*670-1349-02	B010100	B119999	Complete Board
*670-1349-04	B120000	B219999	Complete Board
*670-1349-06	B220000		Complete Board

CapacitorsTolerance $\pm 20\%$ unless otherwise indicated.

C1100	290-0516-00			15 μ F	Elect.	300 V	+50%—10%
C1101	283-0008-00			0.1 μ F	Cer	500 V	
C1102	290-0200-00			12 μ F	Elect.	150 V	
C1103	290-0200-00			12 μ F	Elect.	150 V	
C1104	290-0513-00	B010100	B119999	510 μ F	Elect.	25 V	+75%—10%
C1104	290-0425-00	B120000		100 μ F	Elect.	20 V	
C1105	290-0425-00			100 μ F	Elect.	20 V	
C1106	290-0513-00	B010100	B119999	510 μ F	Elect.	25 V	+75%—10%
C1106	290-0425-00	B120000		100 μ F	Elect.	20 V	
C1107	290-0425-00			100 μ F	Elect.	20 V	
C1110	281-0525-00			470 pF	Cer	500 V	
C1115	283-0192-00			0.47 μ F	Cer	3 V	+80%—20%
C1126	283-0000-00	B010100	B219999	0.001 μ F	Cer	500 V	
C1126	283-0078-00	B220000		0.001 μ F	Cer	500 V	
C1130	283-0111-00			0.1 μ F	Cer	50 V	
C1136	283-0054-00			150 pF	Cer	200 V	5%

Electrical Parts List—432/R432

A10 SECONDARY POWER SUPPLY Circuit Board Assembly (cont)

Ckt. No.	Tektronix Part No.	Serial/Model No. Eff	Disc	Description			
Semiconductor Device, Diodes							
CR1016	152-0497-00			Silicon	Rectifier bridge, 600 V, 1.5A		
CR1100	152-0331-00			Silicon	Fast recovery 800 V, 25 mA		
CR1102	152-0413-00			Silicon	Rectifier, fast recovery, 400 V, 0.75 A		
CR1104	152-0412-00			Silicon	Rectifier, fast recovery, 50 V, 3A		
CR1106	152-0412-00			Silicon	Rectifier, fast recovery, 50 V, 3A		
CR1110	*152-0185-00			Silicon	Replaceable by 1N4152		
CR1132	*152-0185-00			Silicon	Replaceable by 1N4152		
CR1138	*152-0185-00			Silicon	Replaceable by 1N4152		
CR1150	*152-0185-00			Silicon	Replaceable by 1N4152		
VR1110	152-0195-00			Zener	1N751A 400 mW, 5.1 V, 5%		
VR1140	152-0306-00	B010100	B119999X	Zener	1N960B 400 mW, 9.1 V, 5%		
Inductors							
L1106	*108-0646-00			80 μ H			
L1104	*108-0646-00			80 μ H			
L1106	*108-0646-00			80 μ H			
Transistors							
Q1138	151-0508-00			Silicon	PNPN	TO-98	D13T1
Q1150	*151-0190-01			Silicon	NPN	TO-106	Tek Spec
Resistors							
Resistors are fixed, composition, $\pm 10\%$ unless otherwise indicated.							
R1101	316-0101-00			100 Ω	$\frac{1}{4}$ W		
R1110	316-0221-00			220 Ω	$\frac{1}{4}$ W		
R1112	316-0104-00			100 k Ω	$\frac{1}{4}$ W		
R1114	316-0823-00			82 k Ω	$\frac{1}{4}$ W		
R1115	316-0102-00			1 k Ω	$\frac{1}{4}$ W		
R1120	321-0273-00	B010100	B239999	6.81 k Ω	$\frac{1}{8}$ W	Prec	1%
R1120	321-0271-00	B240000		6.49 k Ω	$\frac{1}{8}$ W	Prec	1%
R1122	311-0635-00			1 k Ω , Var			
R1124	321-0265-00	B010100	B239999	5.62 k Ω	$\frac{1}{8}$ W	Prec	1%
R1124	321-0267-00	B240000		5.9 k Ω	$\frac{1}{8}$ W	Prec	1%
R1132	316-0474-00			470 k Ω	$\frac{1}{4}$ W		
R1136	316-0102-00			1 k Ω	$\frac{1}{4}$ W		

A10 SECONDARY POWER SUPPLY Circuit Board Assembly (cont)

Ckt. No.	Tektronix Part No.	Serial/Model No. Eff	Disc	Description	
Resistors (cont)					
R1137	316-0102-00	B010100	B119999	1 kΩ	1/4 W
R1137	315-0122-00	B120000		1.2 kΩ	1/4 W
R1138	316-0103-00			10 kΩ	1/4 W
R1139	316-0471-00			470 Ω	1/4 W
R1140	315-0182-00	XB120000		1.8 kΩ	1/4 W
					5%
R1142	316-0333-00			33 kΩ	1/4 W
R1150	316-0152-00			1.5 kΩ	1/4 W

Switch

	Wired or Unwired				
S1010	260-0834-00			Push-pull	POWER

Transformers

T1100	*120-0723-00			Toroid, 7 windings	
T1115	*120-0716-00			Line trigger	
T1150	*120-0719-00			Pot core	

Integrated Circuit

U1130	156-0053-00			Volt. reg, replaceable by Fairchild μ A723C	
-------	-------------	--	--	---	--

TRANSFORMER Assembly

	*120-0715-00	B010100	B209999	Complete Transformer Assembly	
	*120-0715-01	B210000	B219999	includes:	
	*120-0715-02	B220000			
A11				PRIMARY TRANSFORMER Circuit Board Assembly	
A12				SECONDARY TRANSFORMER Circuit Board Assembly	

Capacitors

Tolerance $\pm 20\%$ unless otherwise indicated.

C1180	283-0068-00	B010100	B209999	0.01 μ F	Cer	500 V
C1180	285-1065-00	B210000		0.01 μ F	Tub.	600 V
C1181	283-0021-00			0.001 μ F	Cer	5000 V
C1182	283-0068-00	B010100	B209999	0.01 μ F	Cer	500 V
C1182	285-1065-00	B210000		0.01 μ F	Tub.	600 V
C1184	283-0068-00	B010100	B209999	0.01 μ F	Cer	500 V
C1184	285-1065-00	B210000		0.01 μ F	Tub.	600 V
C1186	283-0068-00	B010100	B209999	0.01 μ F	Cer	500 V
C1186	285-1065-00	B210000		0.01 μ F	Tub.	600 V

Electrical Parts List—432/R432

TRANSFORMER Assembly (cont)

Ckt. No.	Tektronix Part No.	Serial/Model No. Eff	Disc		Description	
Capacitors (cont)						
C1188	283-0068-00	B010100	B209999	0.01 μ F	Cer	500 V
C1188	285-1065-00	B210000		0.01 μ F	Tub.	600 V
C1190	283-0068-00	B010100	B209999	0.01 μ F	Cer	500 V
C1190	285-1065-00	B210000		0.01 μ F	Tub.	600 V
C1192	283-0068-00	B010100	B209999	0.01 μ F	Cer	500 V
C1192	285-1065-00	B210000		0.01 μ F	Tub.	600 V
C1194	283-0068-00	B010100	B209999	0.01 μ F	Cer	500 V
C1194	285-1065-00	B210000		0.01 μ F	Tub.	600 V
C1196	283-0068-00	B010100	B209999	0.01 μ F	Cer	500 V
C1196	285-1065-00	B210000		0.01 μ F	Tub.	600 V
C1198	283-0068-00	B010100	B209999	0.01 μ F	Cer	500 V
C1198	285-1065-00	B210000		0.01 μ F	Tub.	600 V
C1199	290-0167-00			10 μ F	Elect.	15 V

Semiconductor Device, Diodes

CR1180	152-0170-00		Silicon	1N4441
CR1182	152-0170-00		Silicon	1N4441
CR1184	152-0170-00		Silicon	1N4441
CR1186	152-0170-00		Silicon	1N4441
CR1188	152-0170-00		Silicon	1N4441
CR1190	152-0170-00		Silicon	1N4441
CR1192	152-0170-00		Silicon	1N4441
CR1194	152-0170-00		Silicon	1N4441
CR1196	152-0170-00		Silicon	1N4441
CR1198	152-0170-00		Silicon	1N4441
CR1199	152-0413-00		Silicon	Rectifier, fast recovery, 400 V, 0.75 A

Resistors

Resistors are fixed, composition, $\pm 10\%$ unless otherwise indicated.

R1180	316-0103-00	10 k Ω	$\frac{1}{4}$ W
R1198	316-0103-00	10 k Ω	$\frac{1}{4}$ W

Transformer

T1085¹

¹Not individually replaceable. Furnished as a unit with *120-0715-02. See Fig. 8-21.

A13 LINE FILTER Assembly

Ckt. No.	Tektronix Part No.	Serial/Model No. Eff	No. Disc	Description
----------	--------------------	----------------------	----------	-------------

*119-0295-00 Complete Line Filter Assembly

Capacitors

Tolerance $\pm 20\%$ unless otherwise indicated.

C1004	283-0263-00		0.0022 μF	Cer	300 V	
C1106	283-0263-00		0.0022 μF	Cer	300 V	

Line Filter Assembly

FL1010 ¹				Line filter assembly
---------------------	--	--	--	----------------------

Inductor

L1004	*108-0660-00			Two 240 μH toroidal inductors, potted
-------	--------------	--	--	--

Resistor

Resistors are fixed, composition, $\pm 10\%$ unless otherwise indicated.

R1004	315-0102-00	B010100	B019999	1 k Ω	1/4 W	5%
R1004	316-0472-00	B020000		4.7 k Ω	1/4 W	

Transformer

T1004	*120-0725-00			Common mode rejection
-------	--------------	--	--	-----------------------

A14 Z AXIS Circuit Board Assembly

*670-1332-00	B010100	B059999	Complete Board
*670-1332-02	B060000	B179999	Complete Board
*670-1332-03	B180000	B189999	Complete Board
*670-1332-04	B190000		Complete Board

Capacitors

Tolerance $\pm 20\%$ unless otherwise indicated.

C902	283-0594-00		0.001 μF	Mica	100 V	1%
C906	*285-0758-01		0.05 μF	PTM	400 V	2%
C919	290-0135-00		15 pF	Elect.	20 V	
C921	283-0000-00		0.001 μF	Cer	500 V	

¹Not individually replaceable.

A14 Z AXIS Circuit Board Assembly (cont)

Ckt. No.	Tektronix Part No.	Serial/Model No. Eff	No. Disc	Description		
Capacitors (cont)						
C922	281-0523-00			100 pF	Cer	350 V
C923	281-0628-00	B010100	B229999	15 pF	Cer	600 V
C923	283-0663-00	B230000		16.8 pF	Mica	500 V
C924	283-0021-00	B010100	B159999	0.001 μ F	Cer	5000 V
C924	283-0071-00	B160000		0.0068 μ F	Cer	5000 V
C925	283-0021-00			0.001 μ F	Cer	5000 V
C926	283-0002-00			0.01 μ F	Cer	500 V
C928	283-0068-00			0.01 μ F	Cer	500 V
C932	281-0525-00			470 pF	Cer	500 V
C934	283-0162-00			0.01 μ F	Cer	5000 V
C940	283-0002-00			0.01 μ F	Cer	500 V
C942	283-0083-00			0.0047 μ F	Cer	500 V
C945	283-0002-00			0.01 μ F	Cer	500 V
C952	281-0599-00	B010100	B019999	1 pF	Cer	500 V
C952 ¹	281-0599-00	B020000		1 pF	Cer	500 V
C953	281-0064-00			0.25-1.5 pF, Var	Plastic	Selected
C957	281-0537-00	B010100	B159999	0.68 pF	Cer	500 V
C957	281-0661-00	B160000		0.8 pF	Cer	500 V
C960	283-0032-00			470 pF	Cer	500 V
C961	283-0077-00	B010100	B139999	330 pF	Cer	500 V
C961	281-0518-00	B140000		47 pF	Cer	500 V
C968	283-0000-00			0.001 μ F	Cer	500 V
C980	283-0068-00			0.01 μ F	Cer	500 V
C981	283-0162-00	XB060000		0.01 μ F	Cer	5000 V
C990	283-0162-00			0.01 μ F	Cer	5000 V
C996	290-0523-00			2.2 μ F	Elect.	20 V
C998	290-0523-00			2.2 μ F	Elect.	20 V

Semiconductor Device, Diodes

CR924	*152-0242-00		Silicon	Selected from 1N486A
CR925	*152-0242-00		Silicon	Selected from 1N486A
CR926	*152-0242-00		Silicon	Selected from 1N486A
CR928	*152-0242-00		Silicon	Selected from 1N486A
CR931	*152-0242-00		Silicon	Selected from 1N486A
CR935	*152-0242-00		Silicon	Selected from 1N486A
CR940	152-0333-00		Silicon	High speed and conductance
CR953	*152-0242-00		Silicon	Selected from 1N486A
CR954	*152-0185-00		Silicon	Replaceable by 1N4152
CR955	*152-0185-00		Silicon	Replaceable by 1N4152
CR962	*152-0185-00		Silicon	Replaceable by 1N4152
CR982	152-0333-00		Silicon	High speed and conductance
CR983	152-0333-00		Silicon	High speed and conductance
VR935	152-0241-00		Zener	1N973B 400 mW, 33 V, 5%
VR937	152-0241-00		Zener	1N973B 400 mW, 33 V, 5%

¹May be replaced with a bare wire.

A14 Z AXIS Circuit Board Assembly (cont)

Ckt. No.	Tektronix Part No.	Serial/Model No. Eff	Disc	Description		
Semiconductor Device, Diodes (cont)						
VR940	152-0195-00			Zener	1N751A	400 mW, 5.1 V, 5%
VR943	152-0241-00	XB180000		Zener	1N973B	400 mW, 33 V, 5%
VR944	152-0255-00	B010100	B179999	Zener	1N978B	500 mW, 51 V, 5%
VR944	152-0241-00	B180000		Zener	1N973B	400 mW, 33 V, 5%
VR980	152-0427-00	B010100	B079999	Zener	1N985B	400 mW, 100 V, 5%
VR980	152-0357-00	B080000		Zener	1N983B	400 mW, 82 V, 5%
VR981	152-0283-00	B010100	B079999	Zener	1N976B	400 mW, 43 V, 5%
VR981	152-0285-00	B080000		Zener	1N980B	400 mW, 62 V, 5%
VR985	152-0247-00			Zener	1N989B	400 mW, 150 V, 5%
VR986	152-0247-00			Zener	1N989B	400 mW, 150 V, 5%
VR987	152-0247-00			Zener	1N989B	400 mW, 150 V, 5%
VR988	152-0247-00			Zener	1N989B	400 mW, 150 V, 5%
VR989	152-0247-00			Zener	1N989B	400 mW, 150 V, 5%
VR990	152-0247-00			Zener	1N989B	400 mW, 150 V, 5%
VR994	152-0285-00			Zener	1N980B	400 mW, 62 V, 5%

Transistors

Q905	151-0273-00			Silicon	NPN	TO-98	2N5249
Q910	151-0273-00			Silicon	NPN	TO-98	2N5249
Q915	151-0220-00			Silicon	PNP	TO-18	2N4122
Q924	151-0250-00			Silicon	NPN	TO-106	2N5184
Q925	*151-0228-00			Silicon	PNP	TO-5	Tek Spec
Q940	151-0280-00			Silicon	PNP	TO-5	MM4003
Q950	*151-0124-00			Silicon	NPN	TO-5	Selected from 2N3119
Q954	*151-0190-01			Silicon	NPN	TO-106	Tek Spec
Q955	151-0220-00			Silicon	PNP	TO-18	2N4122
Q989	151-0279-00			Silicon	NPN	TO-39	SE 7056
Q990	151-0279-00			Silicon	NPN	TO-39	SE 7056
Q995	151-0279-00			Silicon	NPN	TO-39	SE 7056

Resistors

Resistors are fixed, composition, $\pm 10\%$ unless otherwise indicated.

R900	321-0298-00	12.4 k Ω	$\frac{1}{8}$ W	Prec	1%
R902	321-0304-00	14.3 k Ω	$\frac{1}{8}$ W	Prec	1%
R904	311-1225-00	1 k Ω , Var			
R905	321-0268-09	6.04 k Ω	$\frac{1}{8}$ W	Prec	1%
R906	321-0357-00	51.1 k Ω	$\frac{1}{8}$ W	Prec	1%
R908	321-0365-09	61.9 k Ω	$\frac{1}{8}$ W	Prec	1%
R910	321-0358-00	52.3 k Ω	$\frac{1}{8}$ W	Prec	1%
R911	315-0202-00	2 k Ω	$\frac{1}{4}$ W		5%
R912	316-0470-00	47 Ω	$\frac{1}{4}$ W		
R915	311-1226-00	2.5 k Ω , Var			

A14 Z AXIS Circuit Board Assembly (cont)

Ckt. No.	Tektronix Part No.	Serial/Model No. Eff	No. Disc	Description		
Resistors (cont)						
R916	322-0301-00			13.3 k Ω	1/4 W	Prec
R918	321-0172-00			604 Ω	1/8 W	Prec
R919	316-0270-00			27 Ω	1/4 W	1%
R920	316-0103-00			10 k Ω	1/4 W	
R921	316-0332-00			3.3 k Ω	1/4 W	
R922	316-0471-00			470 Ω	1/4 W	
R923	316-0474-00			470 k Ω	1/4 W	
R924	316-0102-00			1 k Ω	1/4 W	
R925	316-0471-00			470 Ω	1/4 W	
R926	316-0101-00			100 Ω	1/4 W	
R927	316-0471-00			470 Ω	1/4 W	
R928	316-0395-00			3.9 M Ω	1/4 W	
R930	316-0473-00			47 k Ω	1/4 W	
R931	316-0222-00	B010100	B059999	2.2 k Ω	1/4 W	
R931	321-0305-00	B060000		14.7 k Ω	1/8 W	Prec
R932	316-0221-00			220 Ω	1/4 W	1%
R934	316-0470-00			47 Ω	1/4 W	
R935	316-0103-00	B010100	B059999	10 k Ω	1/4 W	
R935	316-0472-00	B060000	B159999	4.7 k Ω	1/4 W	
R935	316-0103-00	B160000		10 k Ω	1/4 W	
R936	303-0330-00			33 Ω	1 W	5%
R937	316-0104-00			100 k Ω	1/4 W	
R940	315-0114-00			110 k Ω	1/4 W	5%
R941	316-0101-00			100 Ω	1/4 W	
R942	315-0911-00			910 Ω	1/4 W	5%
R943	316-0470-00			47 Ω	1/4 W	
R945	315-0512-00			5.1 k Ω	1/4 W	5%
R946	316-0103-00			10 k Ω	1/4 W	
R948	316-0101-00			100 Ω	1/4 W	
R949	316-0220-00			22 Ω	1/4 W	
R953	316-0101-00			100 Ω	1/4 W	
R954	316-0102-00			1 k Ω	1/4 W	
R955	316-0220-00			22 Ω	1/4 W	
R956	316-0392-00			3.9 k Ω	1/4 W	
R958	323-0363-00			59 k Ω	1/2 W	Prec
R960	315-0566-00			56 M Ω	1/4 W	5%
R961	316-0102-00			1 k Ω	1/4 W	
R962 A	*307-0274-00			39.3 M Ω	Thick film	
R962 B				140 k Ω		
R962 C				4.9 M Ω		
R962 D				29.1 M Ω		
R962 E				600 k Ω		

A14 Z AXIS Circuit Board Assembly (cont)

Ckt. No.	Tektronix Part No.	Serial/Model No. Eff	No. Disc	Description			
Resistors (cont)							
R963	311-1230-00			20 kΩ, Var			
R964	301-0755-00	XB060000		7.5 MΩ (nominal value)	Selected		
R967	311-1251-00			200 kΩ, Var			
R968	311-1257-00	B010100	B189999X	5 MΩ, Var			
R972	321-0382-00			93.1 kΩ	1/8 W	Prec	1%
R973	321-0266-00			5.76 kΩ	1/8 W	Prec	1%
R974	321-0322-00			22.1 kΩ	1/8 W	Prec	1%
R975	321-0236-00			2.8 kΩ	1/8 W	Prec	1%
R976	316-0390-00			39 Ω	1/4 W		
R978	321-0210-00			1.5 kΩ	1/8 W	Prec	1%
R979	321-0250-00			3.92 kΩ	1/8 W	Prec	1%
R980	311-1254-00			1 MΩ, Var			
R981	316-0472-00			4.7 kΩ	1/4 W		
R983	316-0333-00			33 kΩ	1/4 W		
R986	316-0106-00	B010100	B119999	10 MΩ	1/4 W		
R986	316-0335-00	B120000		3.3 MΩ	1/4 W		
R987	316-0106-00	B010100	B119999	10 MΩ	1/4 W		
R987	316-0335-00	B120000		3.3 MΩ	1/4 W		
R988	316-0103-00			10 kΩ	1/4 W		
R990	316-0226-00	B010100	B119999	22 MΩ	1/4 W		
R990	316-0156-00	B120000		15 MΩ	1/4 W		
R994	316-0223-00			22 kΩ	1/4 W		
R995	316-0475-00	B010100	B139999	4.7 MΩ	1/4 W		
R995	316-0225-00	B120000		2.2 MΩ	1/4 W		
R996	316-0220-00			22 Ω	1/4 W		

Transformer

T920	*120-0721-00			Pot core
------	--------------	--	--	----------

Integrated Circuit

U940	*155-0051-00			Monolithic, Z-axis & HV regulator
------	--------------	--	--	-----------------------------------

SECTION 8

DIAGRAMS AND CIRCUIT BOARDS

Symbols and Reference Designators

Electrical components shown on the diagrams are in the following units unless noted otherwise:

Capacitors =	Values one or greater are in picofarads (pF). Values less than one are in microfarads (μ F).
Resistors =	Ohms (Ω)

Symbols used on the diagrams are based on USA Standard Y32.2-1967.

Logic symbology is based on MIL-STD-806B in terms of positive logic. Logic symbols depict the logic function performed and may differ from the manufacturer's data.

The following special symbols are used on the diagrams:

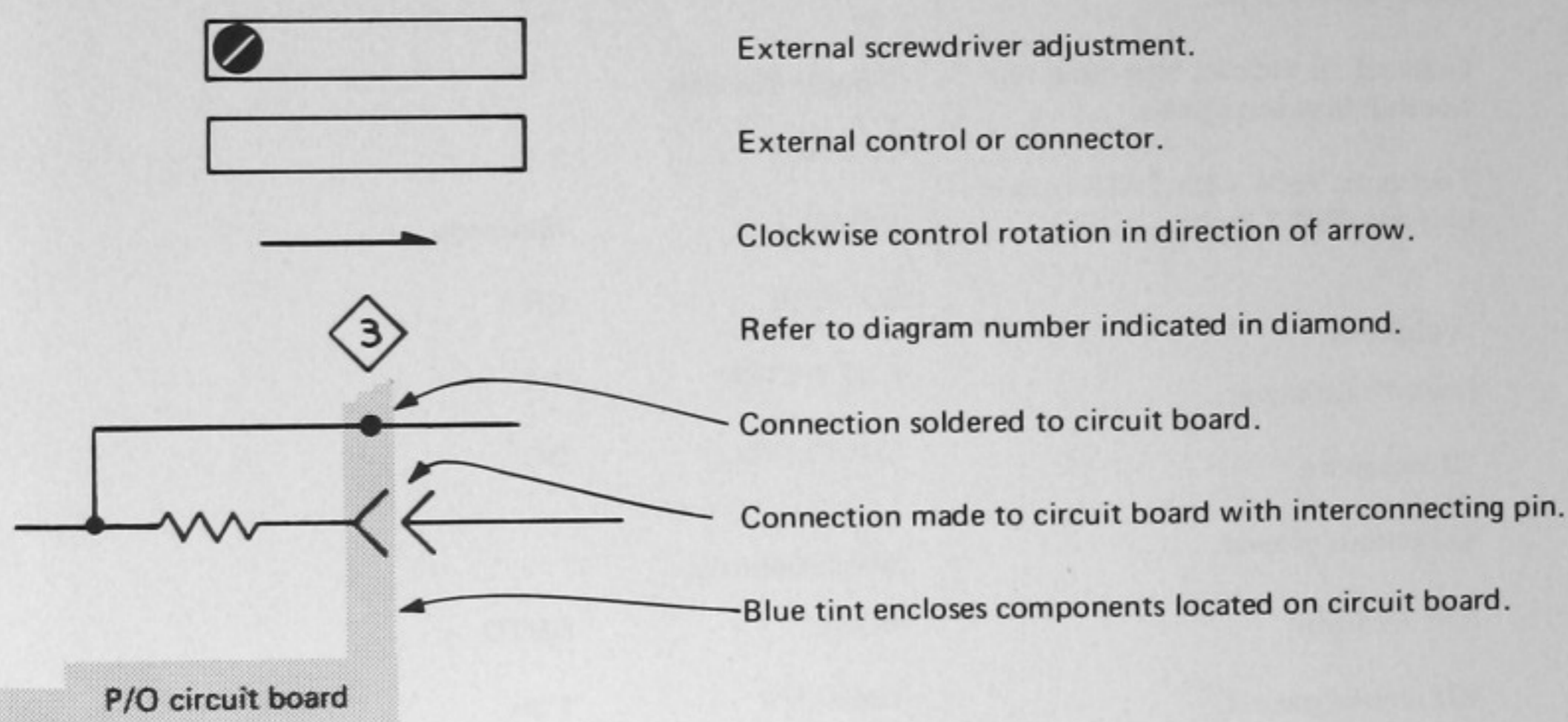

The following prefix letters are used as reference designators to identify components or assemblies on the diagrams.

A	Assembly, separable or repairable (circuit board, etc.)	LR	Inductor/resistor combination
AT	Attenuator, fixed or variable	M	Meter
B	Motor	Q	Transistor or silicon-controlled rectifier
BT	Battery	P	Connector, movable portion
C	Capacitor, fixed or variable	R	Resistor, fixed or variable
CR	Diode, signal or rectifier	RT	Thermistor
DL	Delay line	S	Switch
DS	Indicating device (lamp)	T	Transformer
F	Fuse	TP	Test point
FL	Filter	U	Assembly, inseparable or non-repairable (integrated circuit, etc.)
H	Heat dissipating device (heat sink, heat radiator, etc.)	V	Electron tube
HR	Heater	VR	Voltage regulator (zener diode, etc.)
J	Connector, stationary portion	Y	Crystal
K	Relay		
L	Inductor, fixed or variable		

VOLTAGE AND WAVEFORM TEST CONDITIONS

Typical voltage measurements and waveform photographs were obtained under the following conditions unless noted otherwise on the individual diagrams. Voltage measurements were taken with no signal applied to the vertical input. Waveform photographs were taken with the PROBE CAL 0.6 V 1 kHz signal applied to the CH 1 input connector.

Test Oscilloscope

Frequency response	DC to 40 MHz.
Deflection factor	5 millivolts to 50 volts/division.
Probe ground	432 chassis ground.
Trigger source	External to indicate true time relationship between signals.
Recommended type	Tektronix 7504 with 7A16 plug-in unit and P6052 Probe.

Voltmeter

Type	Digital multimeter.
Input impedance	10 megohms.
Range	432 chassis ground.
Range	0 to 1 kilovolt.
Reference voltage	432 chassis ground.
Recommended type (as used for voltages on diagrams)	Tektronix 7504 with 7D13 Digital Multimeter Plug-In Unit.

432 Conditions

POWER/ INTENSITY	Pulled out (on) and set for normal display intensity.
---------------------	---

Vertical Controls (both channels if applicable)

POSITION	Midrange
OUT: 5 MHz BW	Pushed in
OUT: INVERT	Pushed in
VOLTS/DIV	.1 V
Variable	CAL
Input Coupling	DC
Vertical Mode	CH 1

Trigger Controls

SLOPE	+
LEVEL	Midrange
SOURCE	CH 1
EXT ATTEN	1:1
COUPLING	DC

Sweep Controls

MODE	AUTO
TIME/DIV	1 ms
MAG	X1
Variable	Midrange

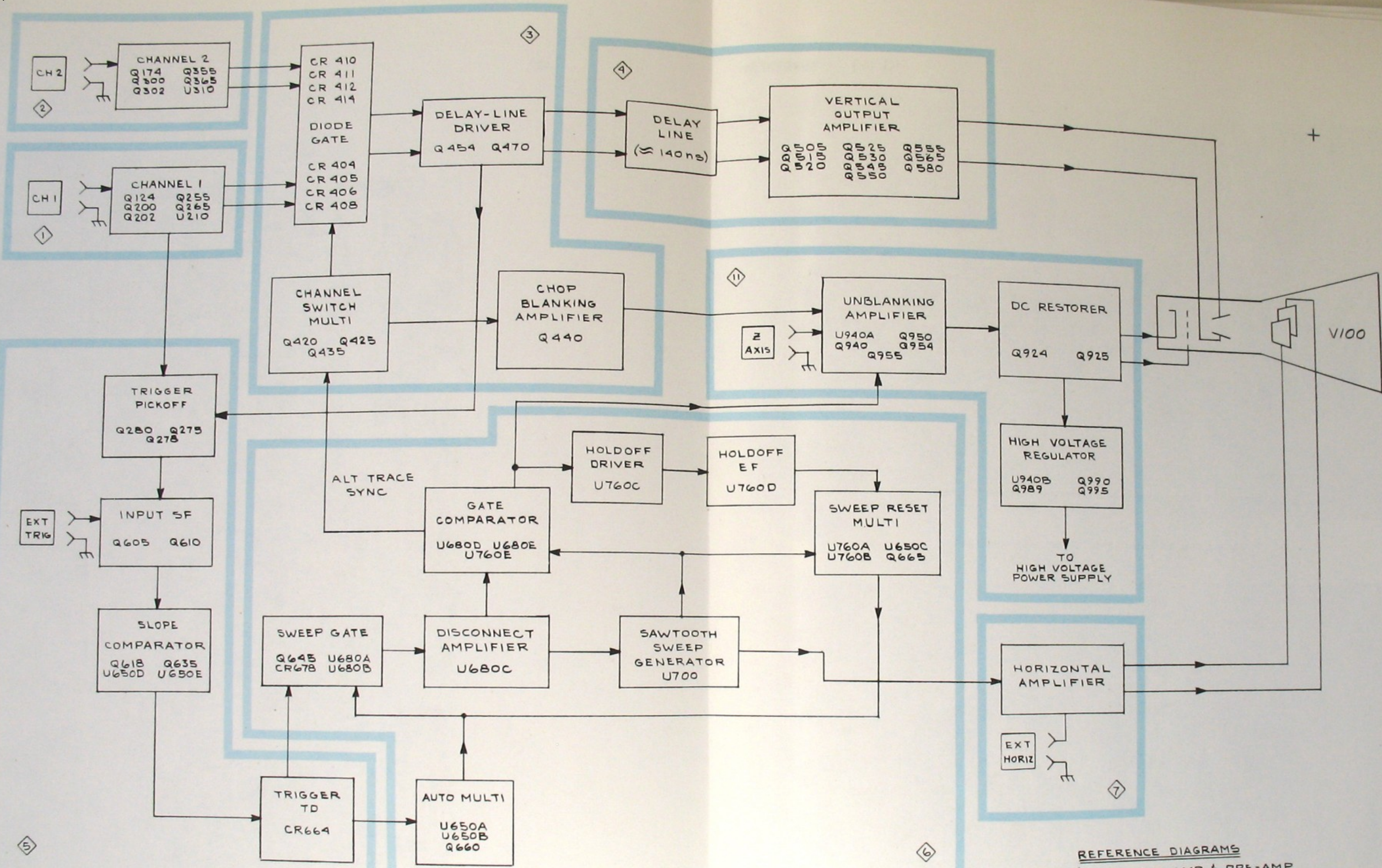

- REFERENCE DIAGRAMS**
- ① CH 1 INPUT AMP & PRE-AMP
 - ② CH 2 INPUT AMP & PRE-AMP
 - ③ CHANNEL SWITCH
 - ④ VERTICAL OUTPUT AMPLIFIER
 - ⑤ TRIGGER PICKOFF & GENERATOR
 - ⑥ SWEEP
 - ⑦ HORIZONTAL AMPLIFIER
 - ⑧ CRT CIRCUIT

BLOCK DIAGRAM

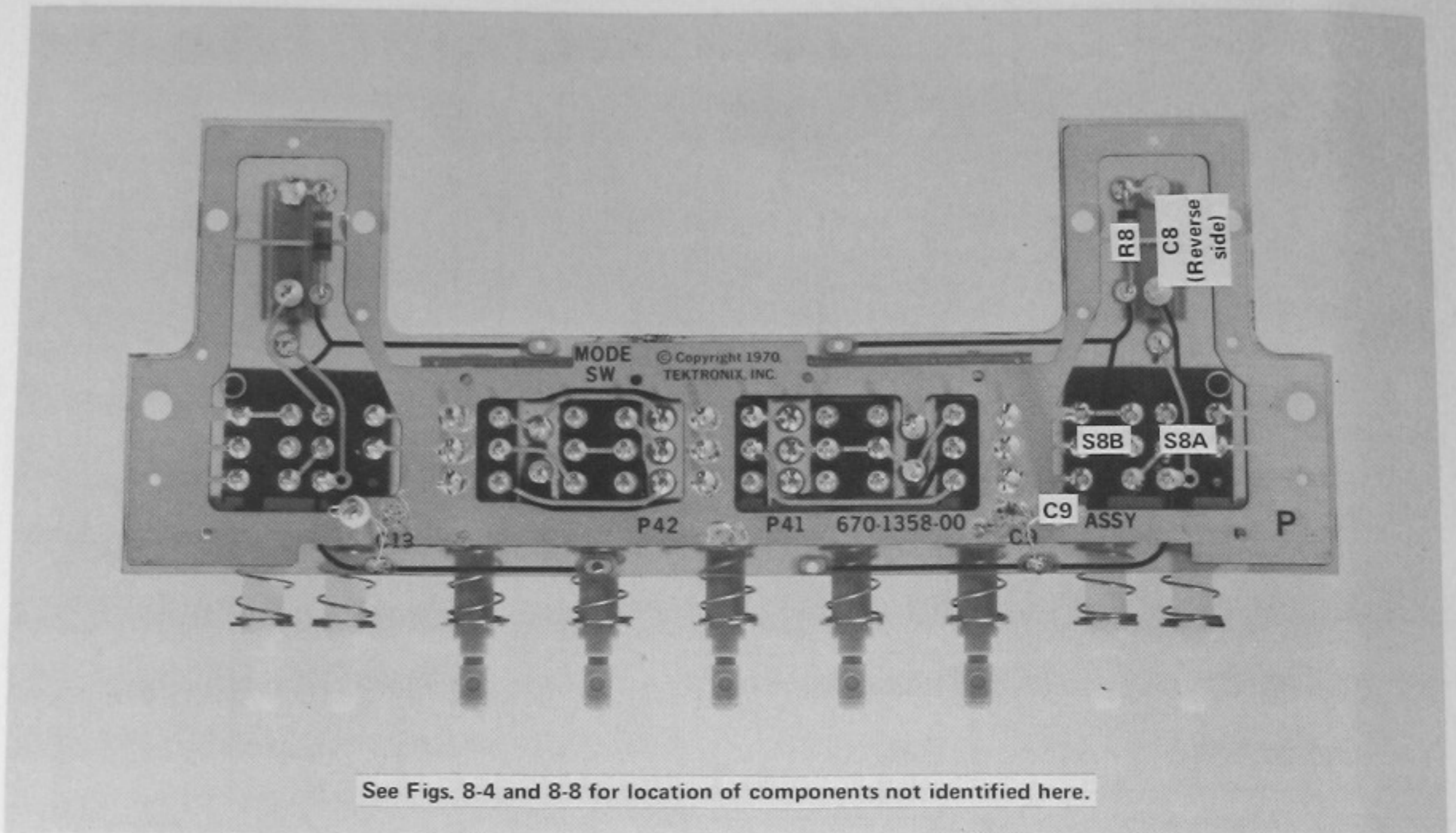

Fig. 8-1. P/O A3. Partial Vertical Mode Switch circuit board.

(A)

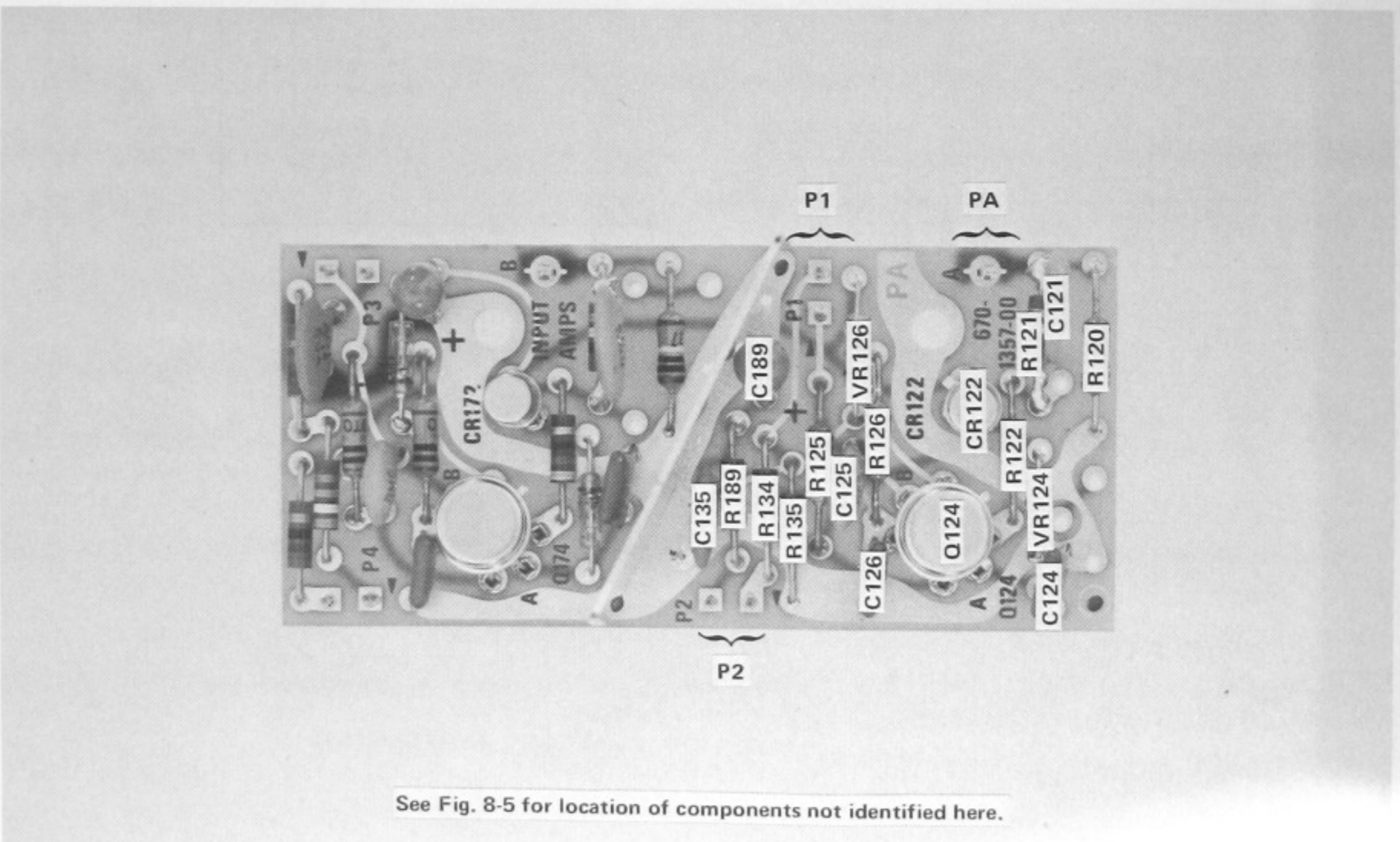
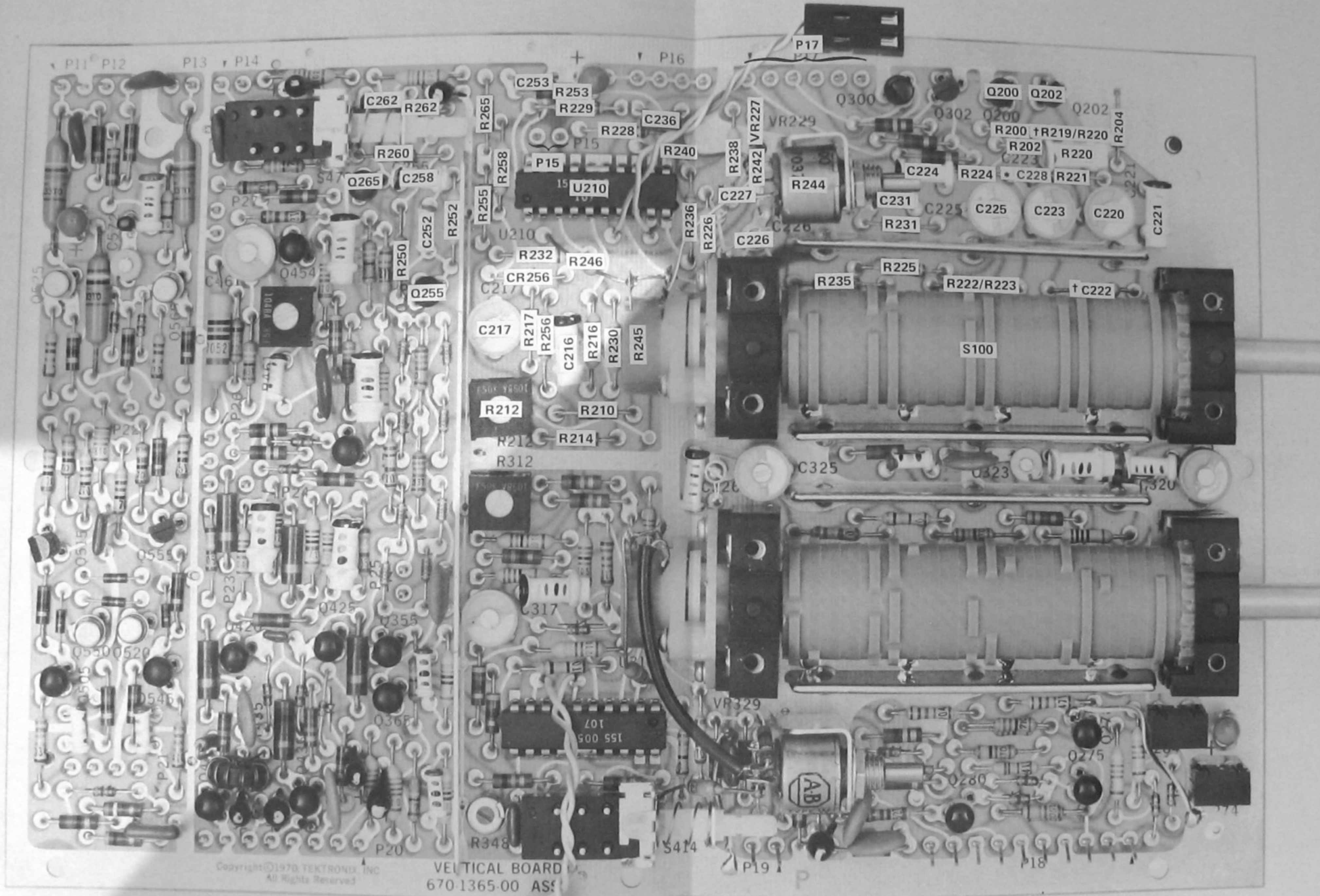

Fig. 8-2. P/O A1. Partial Input Amplifier circuit board.

(A)



Copyright © 1970 TEKTRONIX, INC.
All Rights Reserved

VERTICAL BOARD
670.1365-00 ASSY

*See Parts List for
serial number ranges.

See Figs. 8-6, 8-7, 8-9, and 8-10 for location of components not identified here.
† C222 and R220 board locations reversed in early production.

Fig. 8-3. P/O A2. Partial Vertical circuit board.

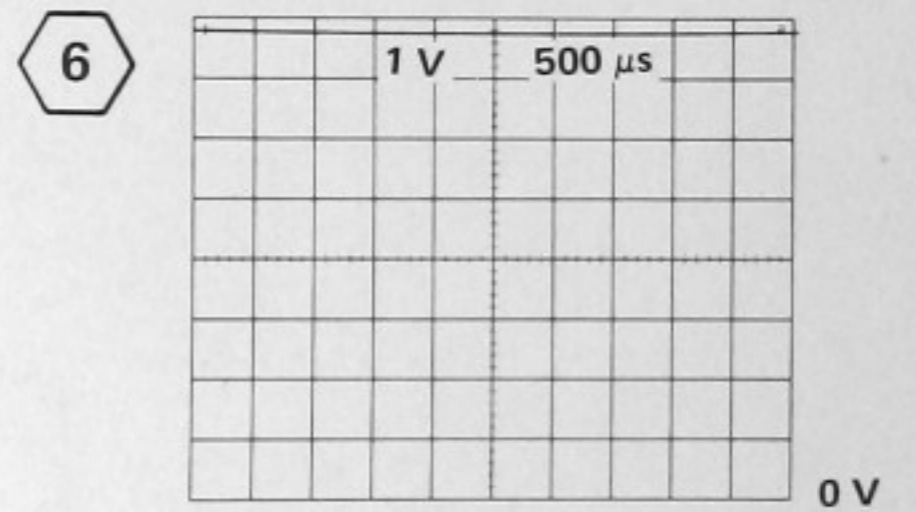
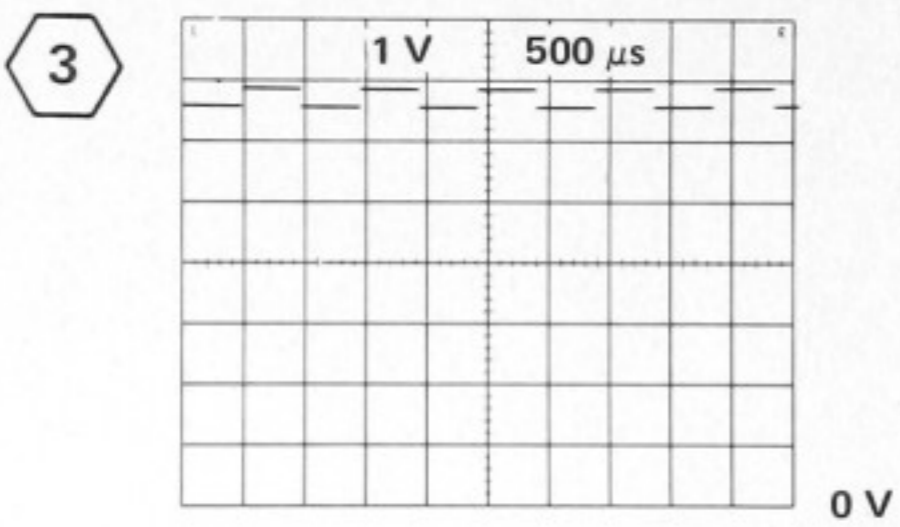
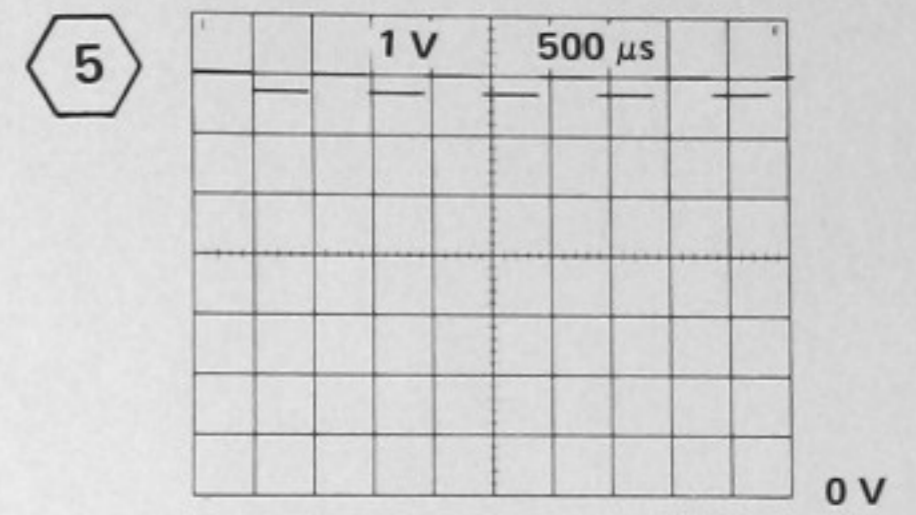
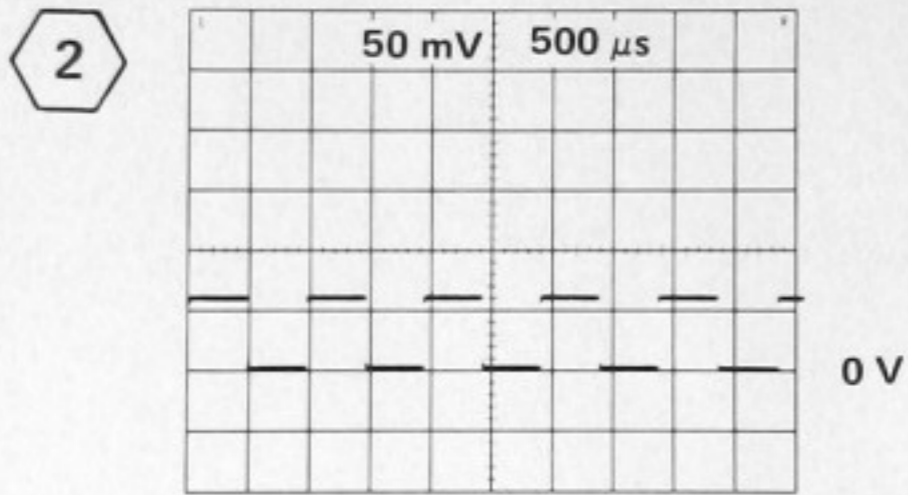
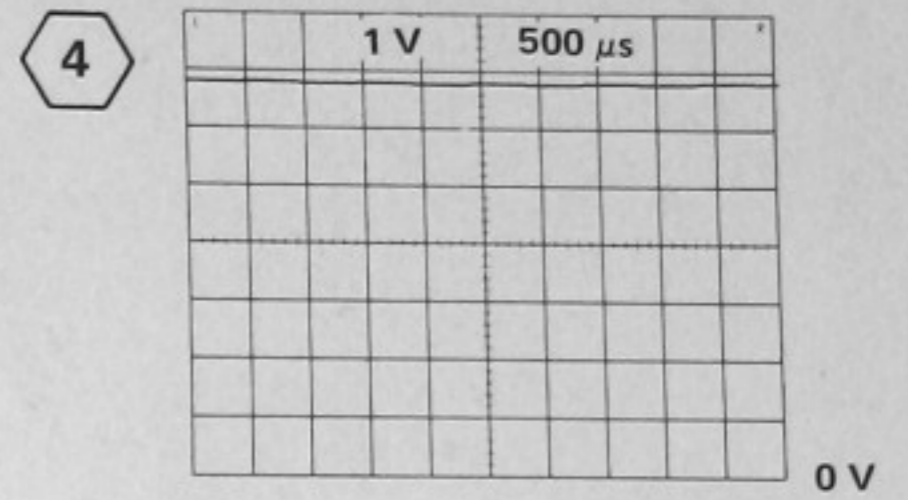
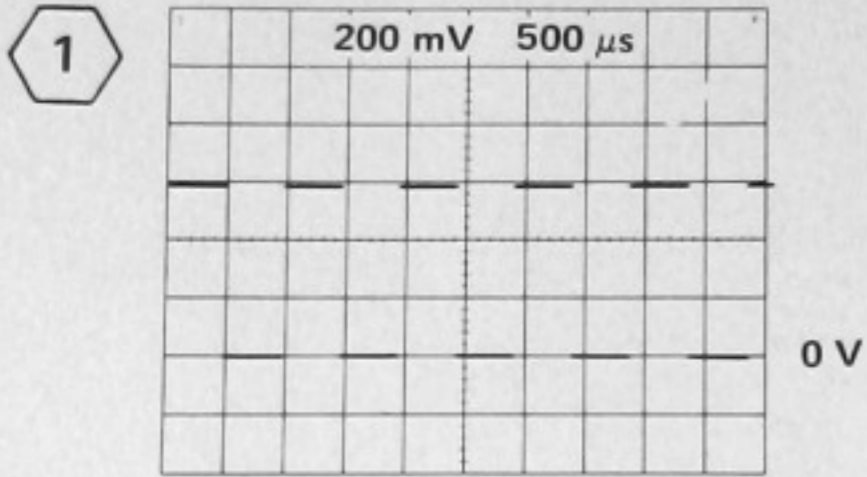

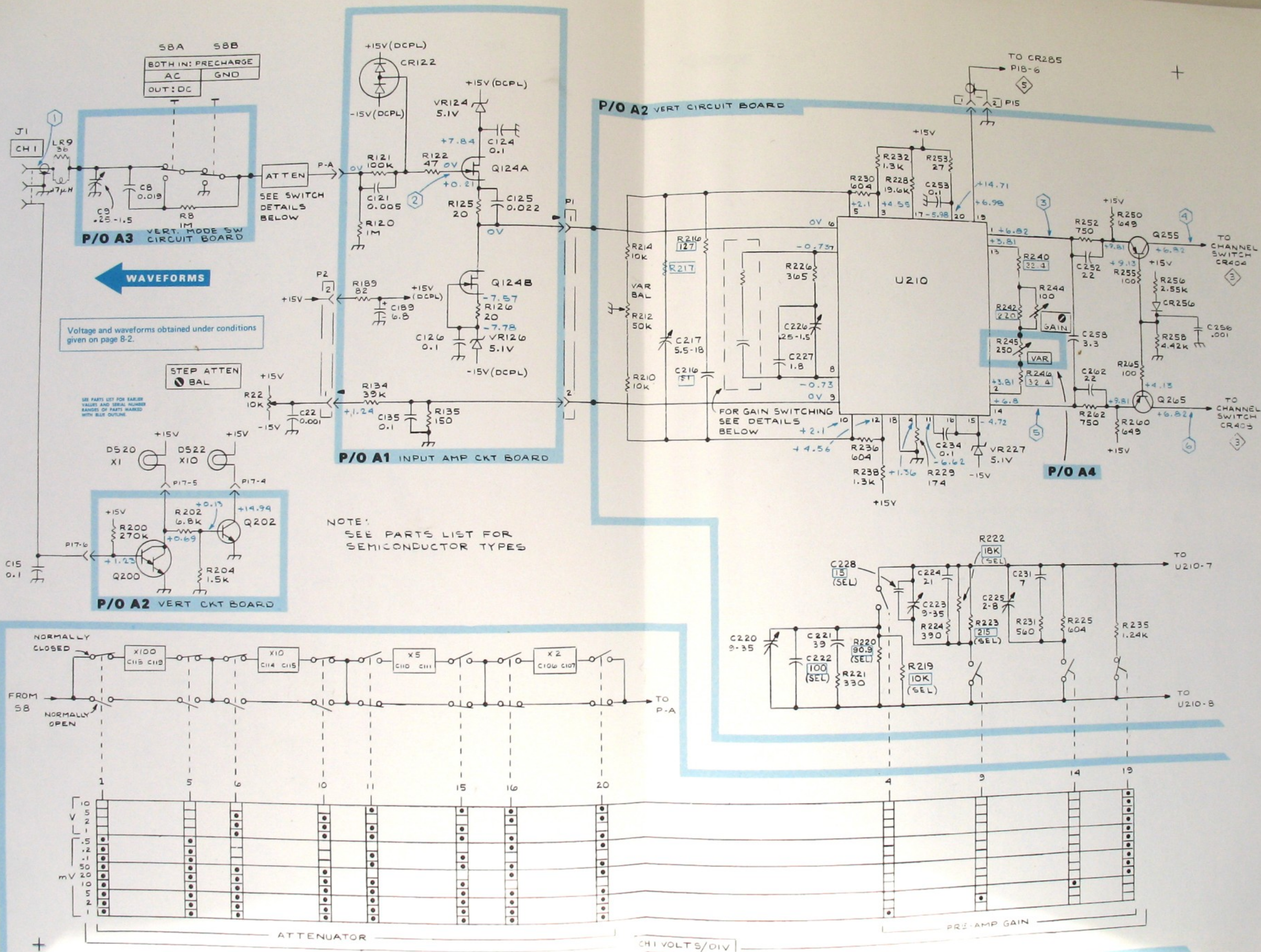

← WAVEFORMS

Voltage and waveforms obtained under conditions given on page B-2.

STEP ATTEN BAL

SEE PARTS LIST FOR EARLIER VALUES AND SERIAL NUMBER RANGES OF PARTS MARKED WITH BLUE OUTLINE

NOTE: SEE PARTS LIST FOR SEMICONDUCTOR TYPES

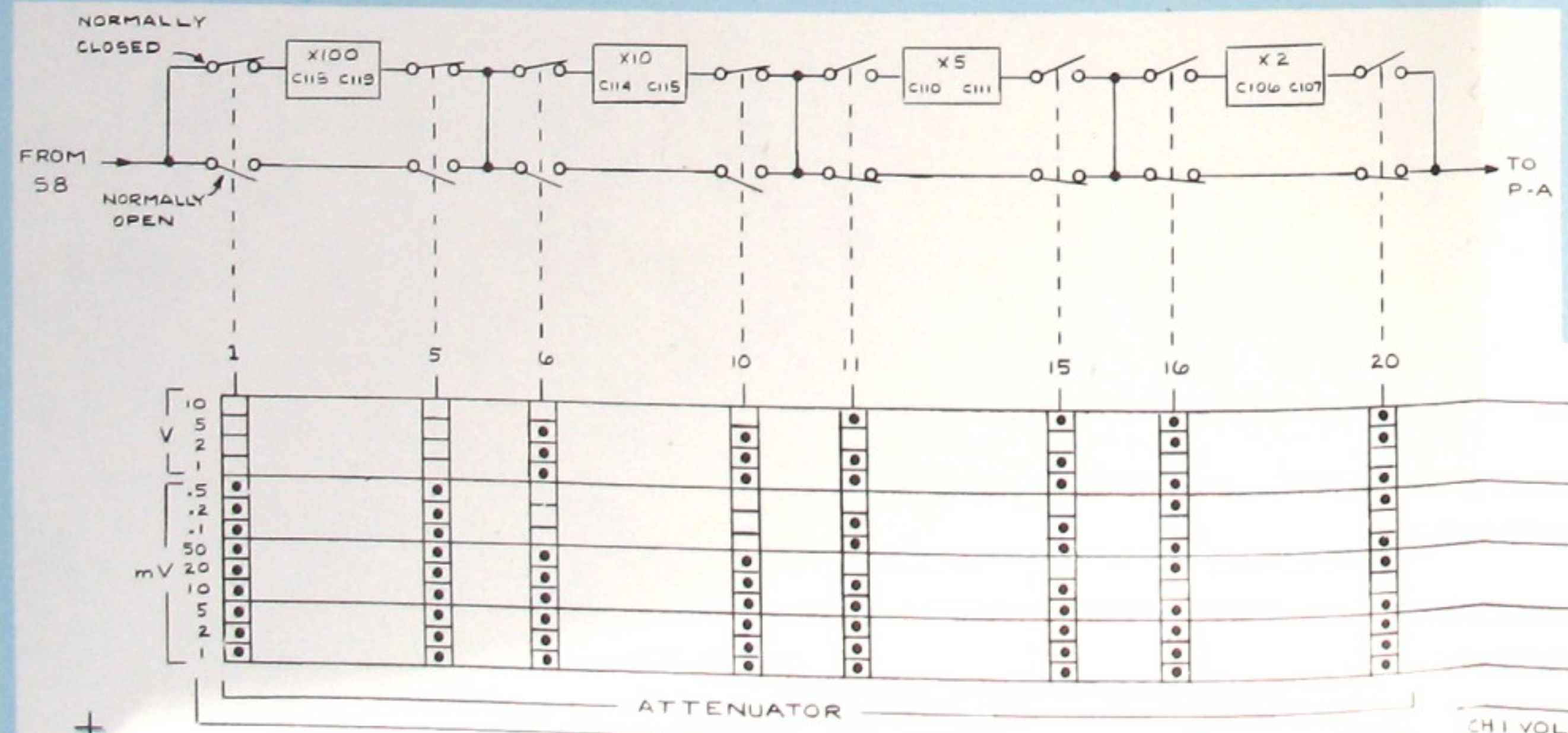

P/O A4 CHI CAM SWITCH

CHI VOLT S/DIV 5100

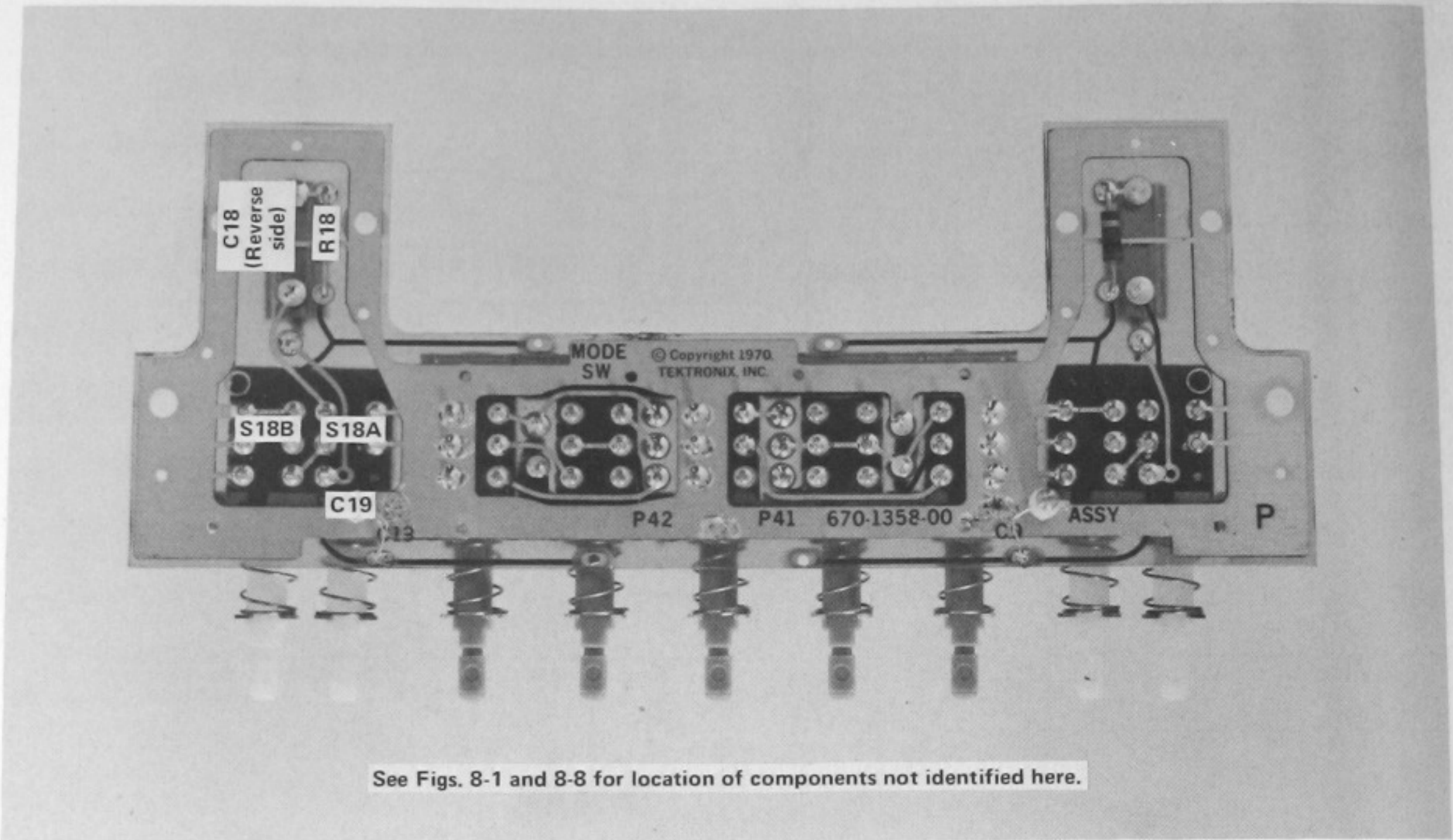

See Figs. 8-1 and 8-8 for location of components not identified here.

Fig. 8-4. P/O A3. Partial Vertical Mode Switch circuit board.

(A)

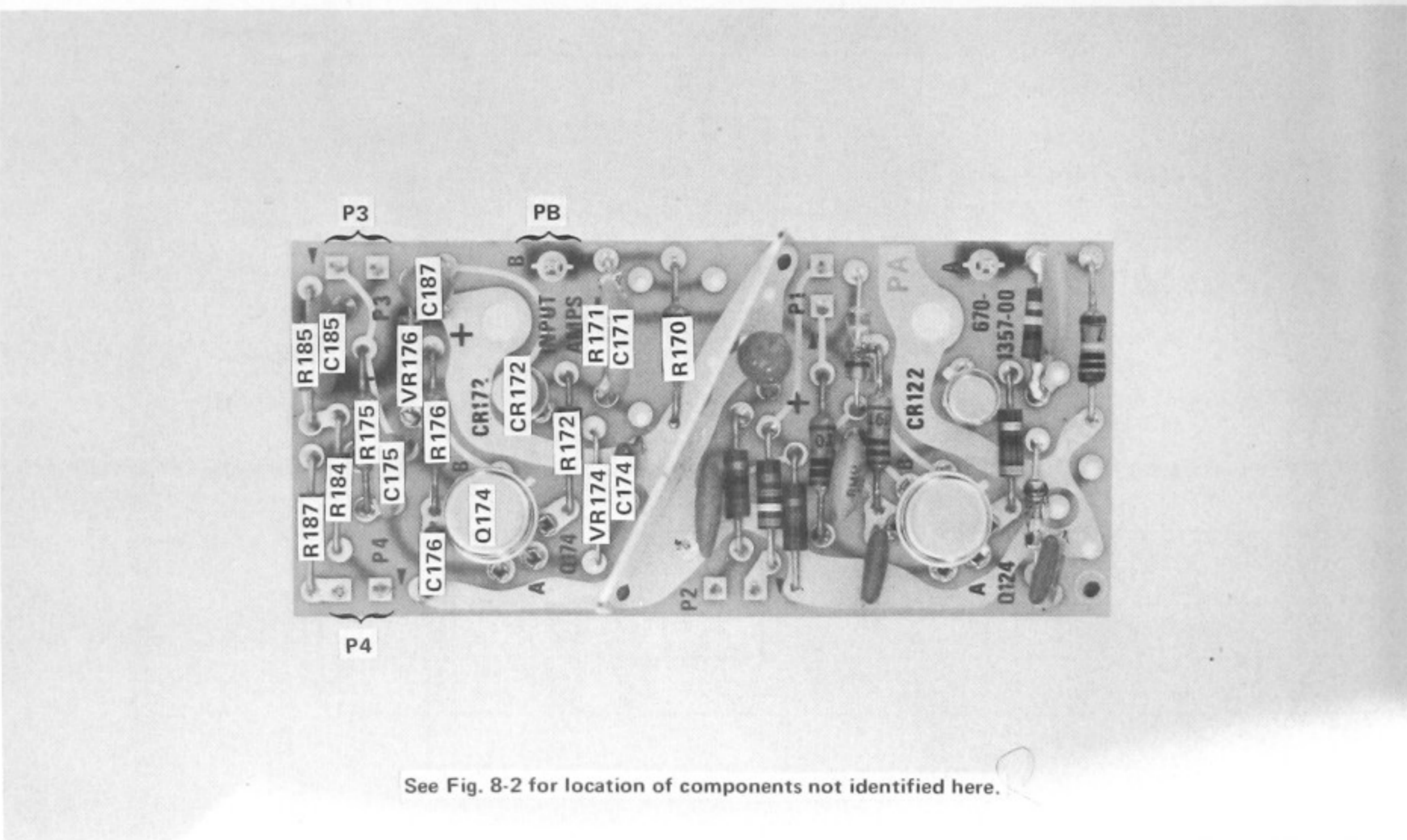

See Fig. 8-2 for location of components not identified here.

Fig. 8-5. P/O A1. Partial Input Amplifier circuit board.

(A)

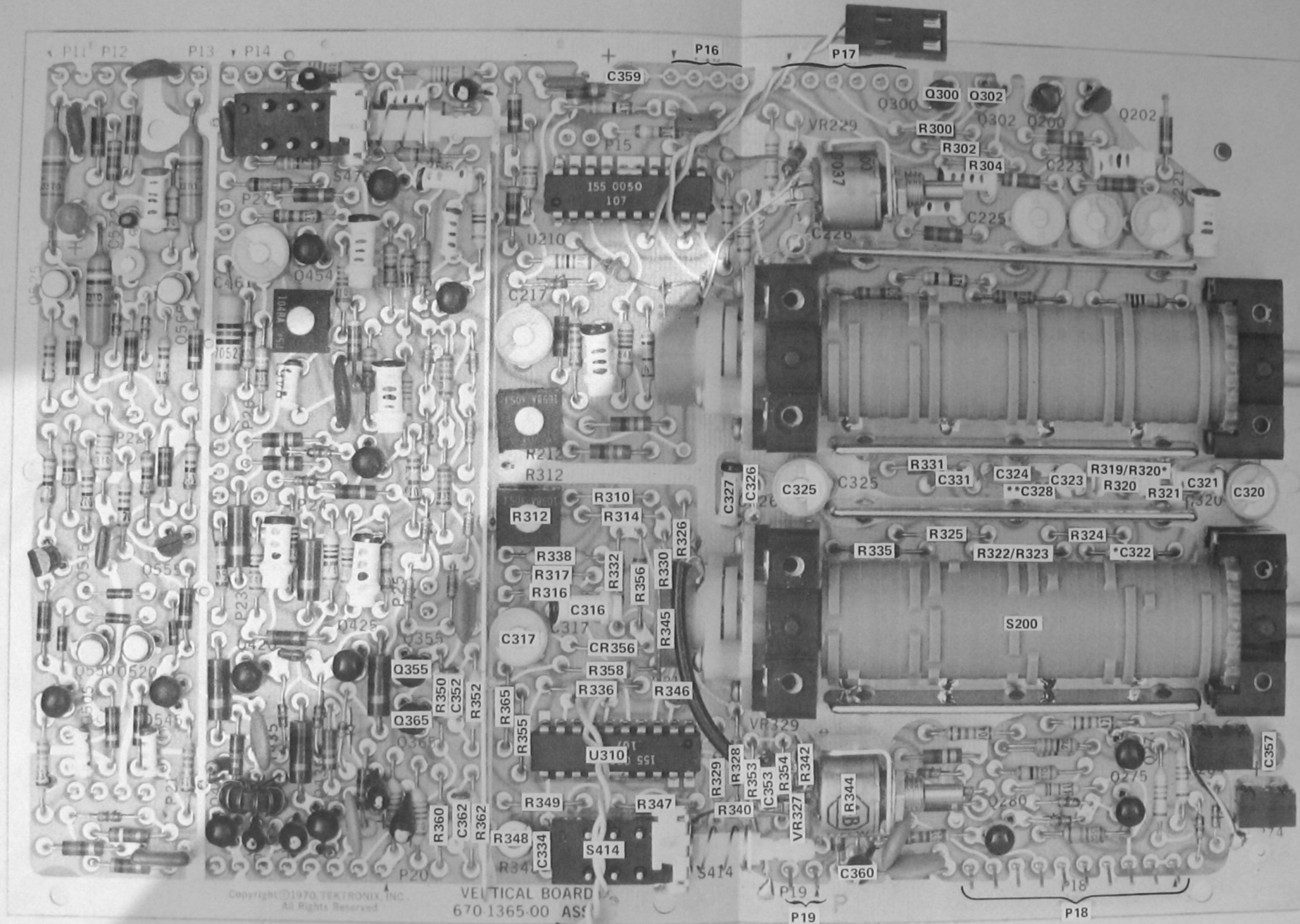

See Figs. 8-3, 8-7, 8-9, and 8-10 for location of components not identified here.
 *C322 and R320 board locations reversed in early production.
 **Added SN B180000

Fig. 8-6. P/O A2. Partial Vertical circuit board.

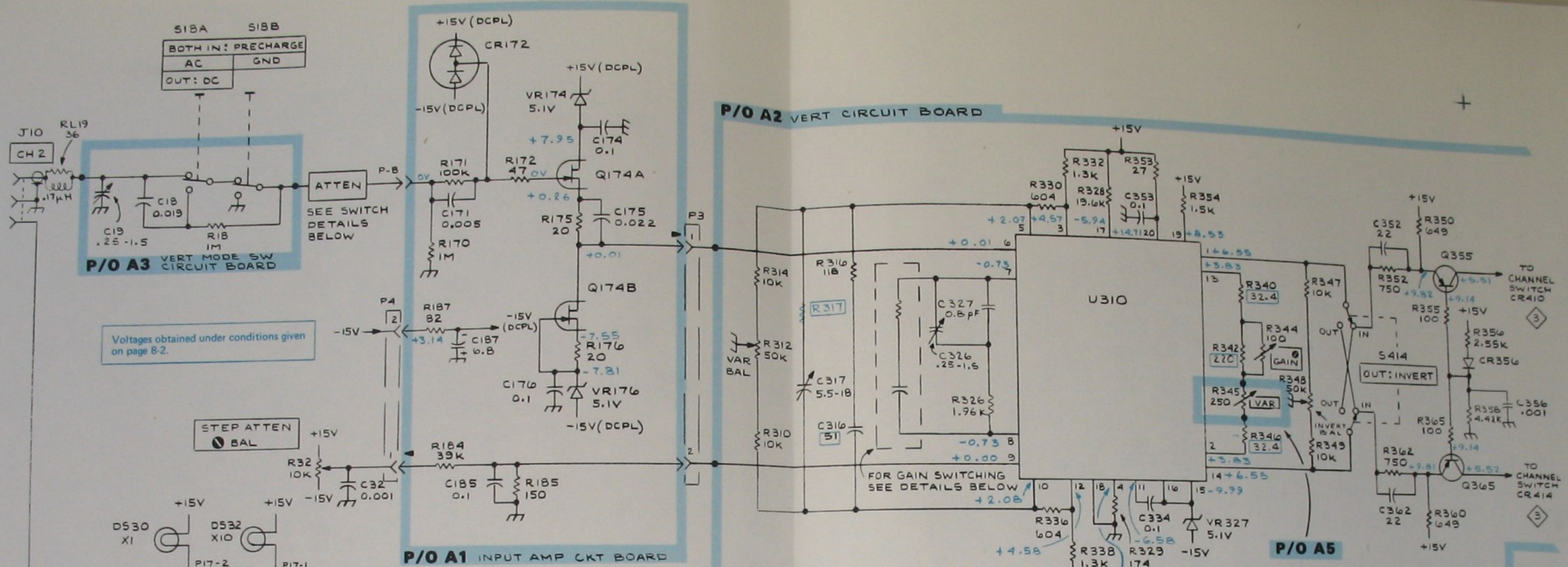

NOTE:
SEE PARTS LIST FOR SEMICONDUCTOR TYPES

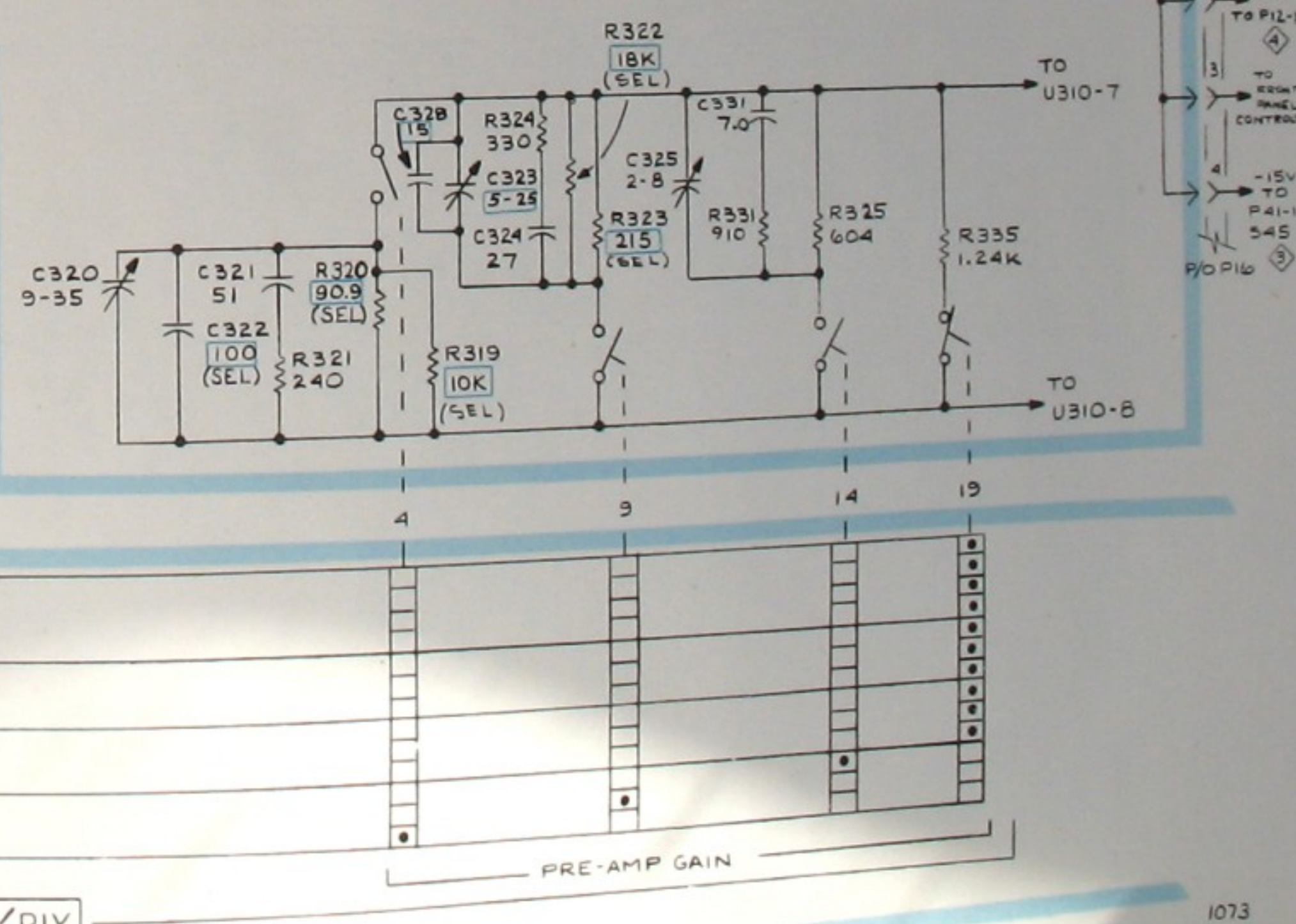
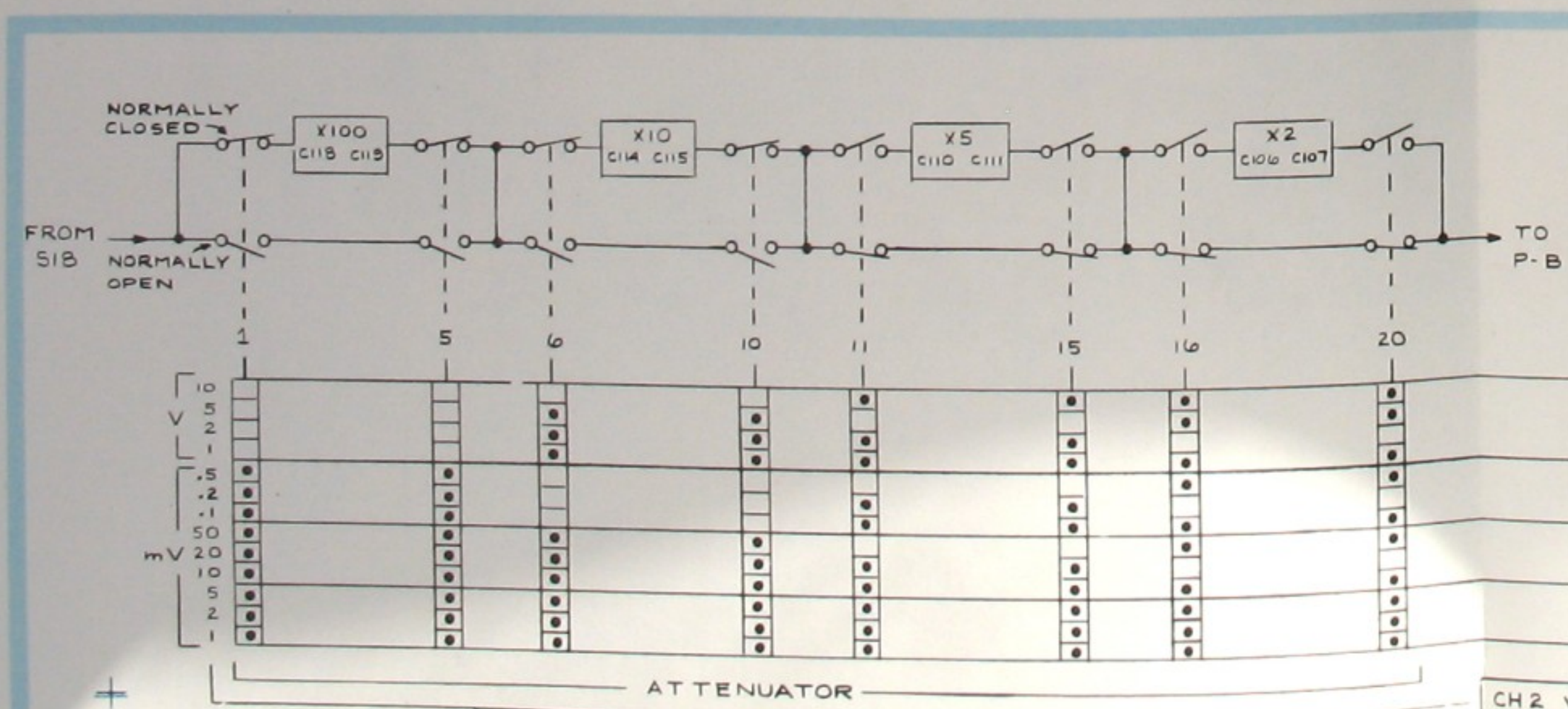

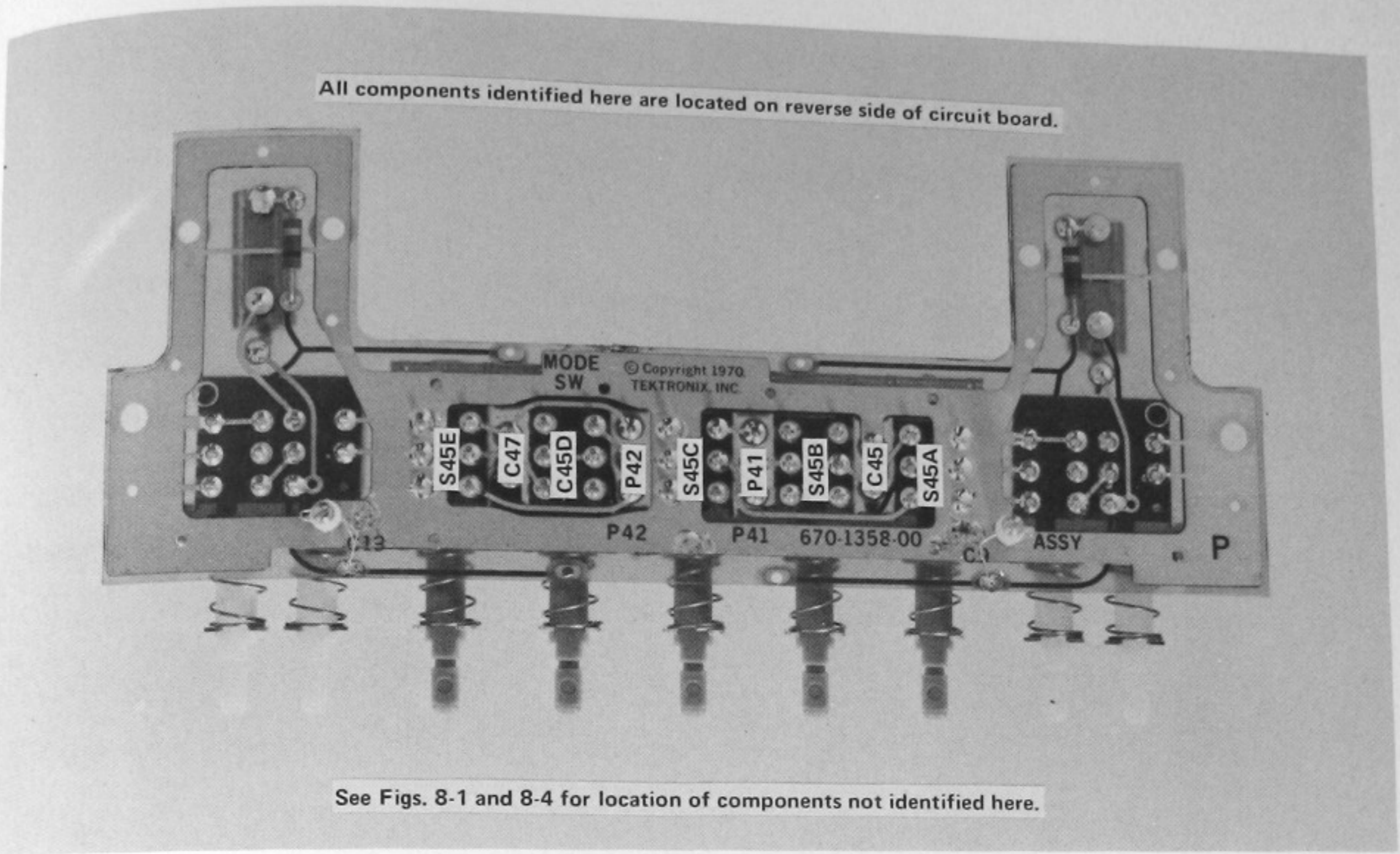
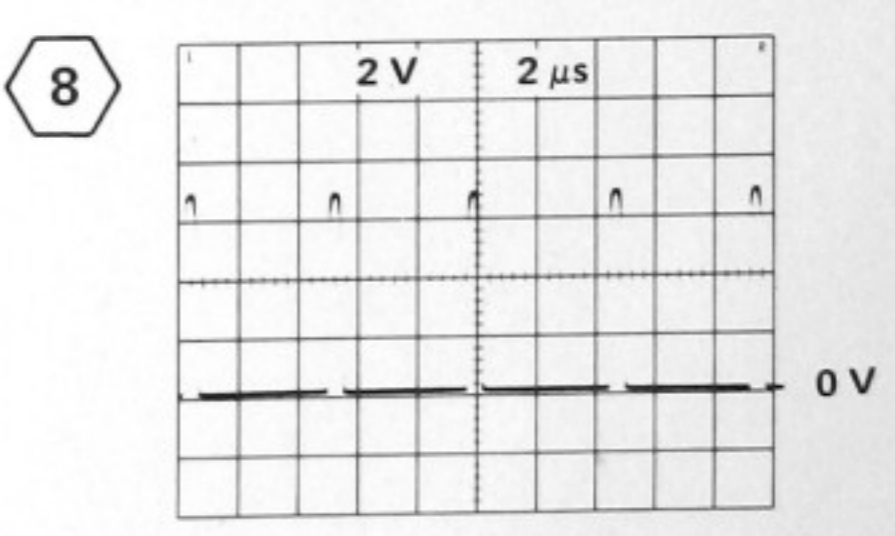
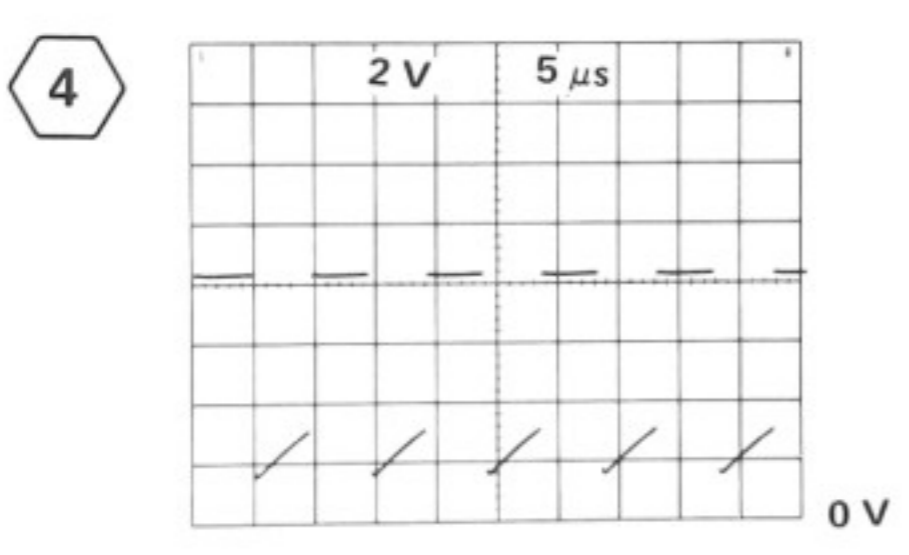
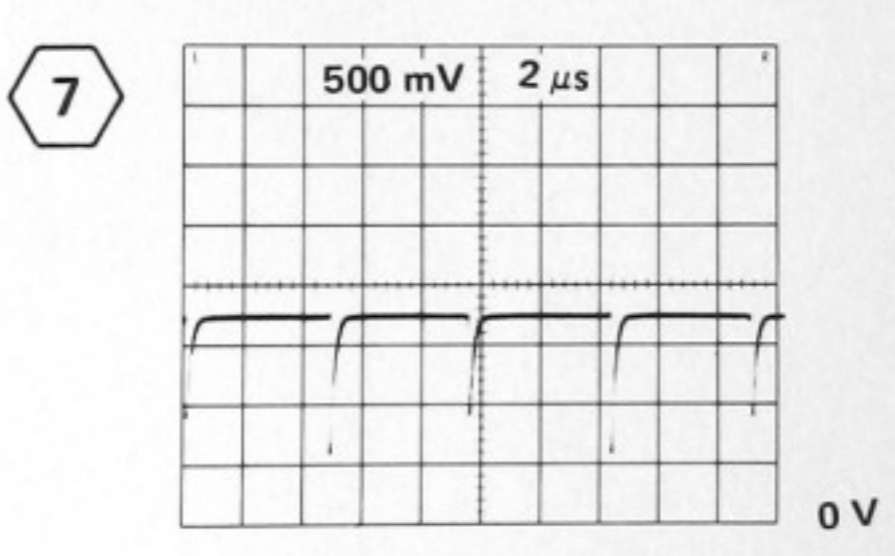
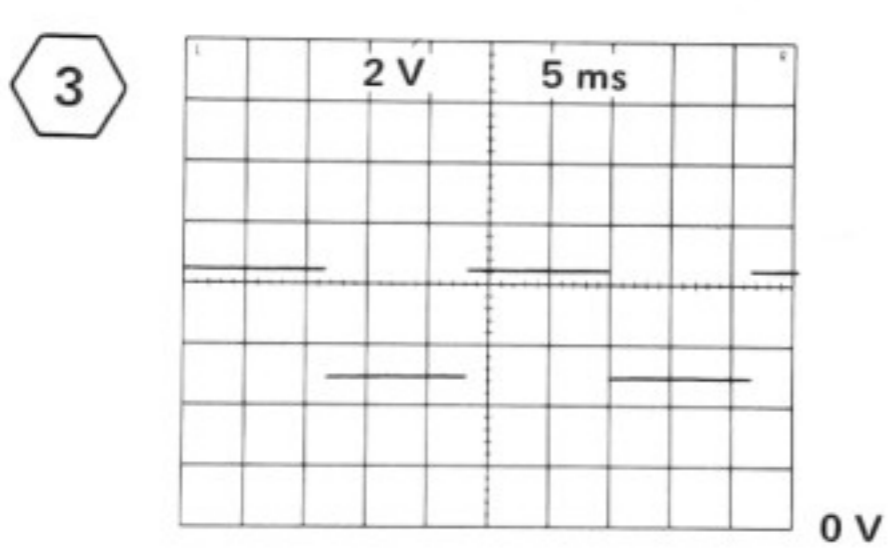
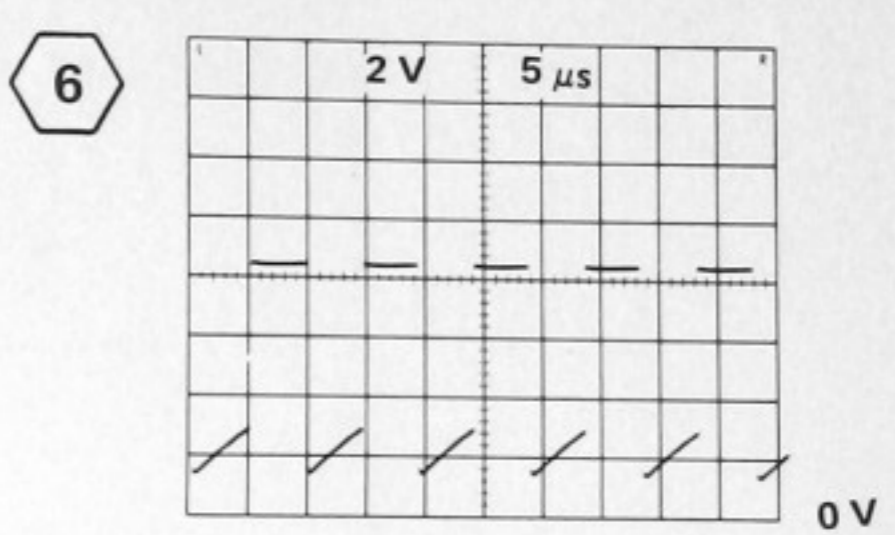
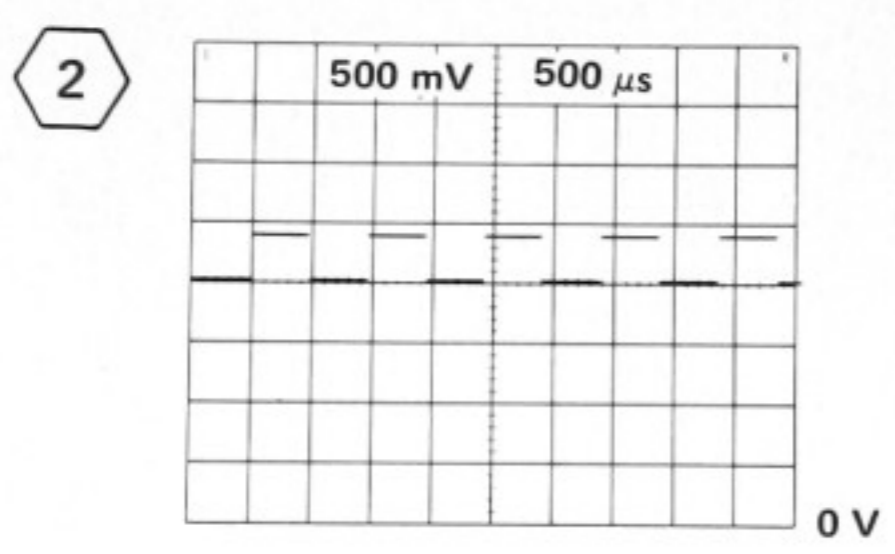
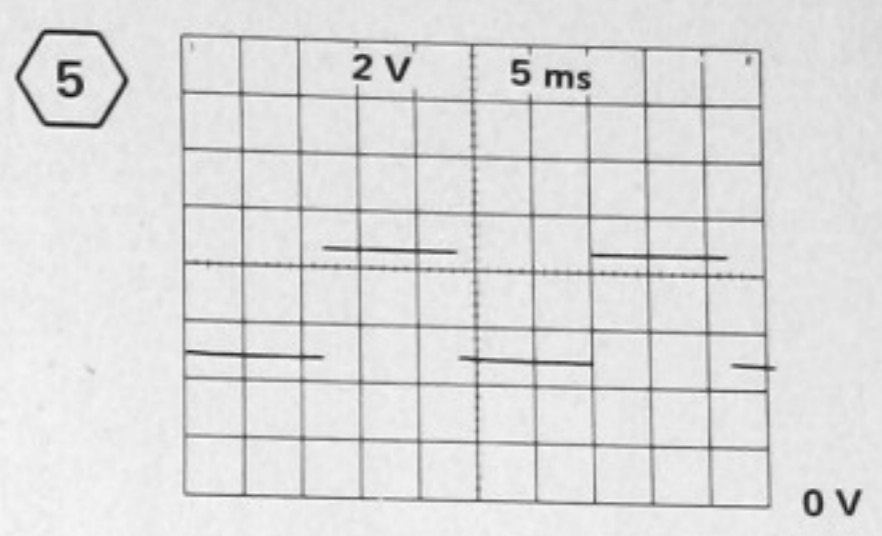
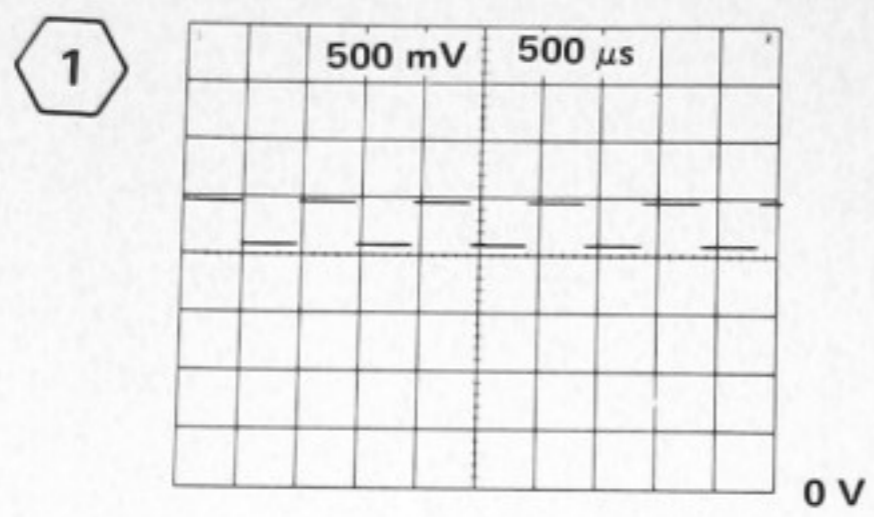
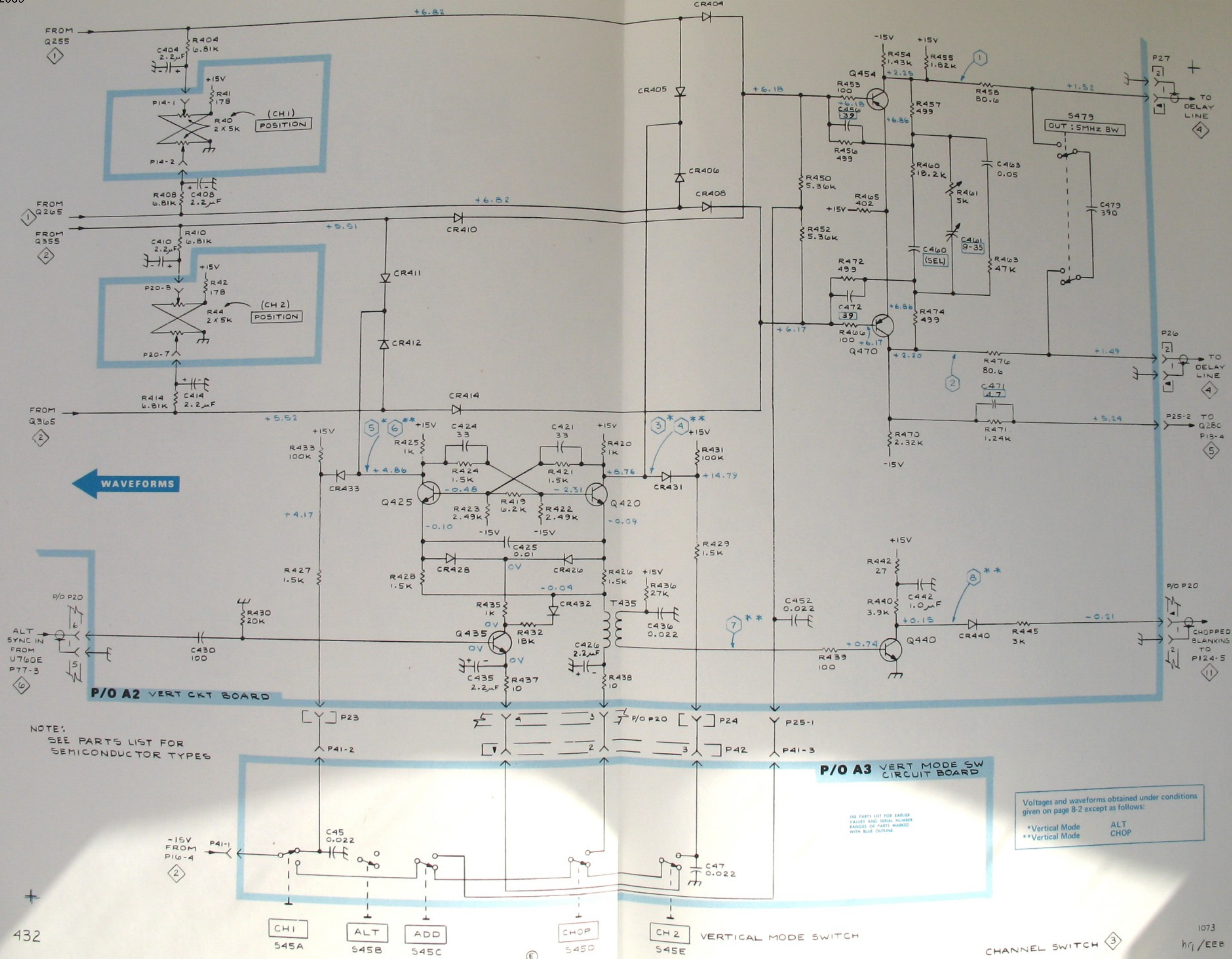

Fig. 8-8. P/O A3. Partial Vertical Mode Switch circuit board.





← WAVEFORMS

P/O A2 VERT CKT BOARD

P/O A3 VERT MODE SW CIRCUIT BOARD

NOTE:
SEE PARTS LIST FOR
SEMICONDUCTOR TYPES

Voltagess and waveforms obtained under conditions
given on page 8-2 except as follows:
*Vertical Mode ALT
**Vertical Mode CHOP

SEE PARTS LIST FOR EARLIER
VALUES AND SERIAL NUMBER
RANGES OF PARTS MARKED
WITH BLUE OUTLINE

CHI 545A ALT 545B ADD 545C CHOP 545D CH 2 545E VERTICAL MODE SWITCH

CHANNEL SWITCH ③

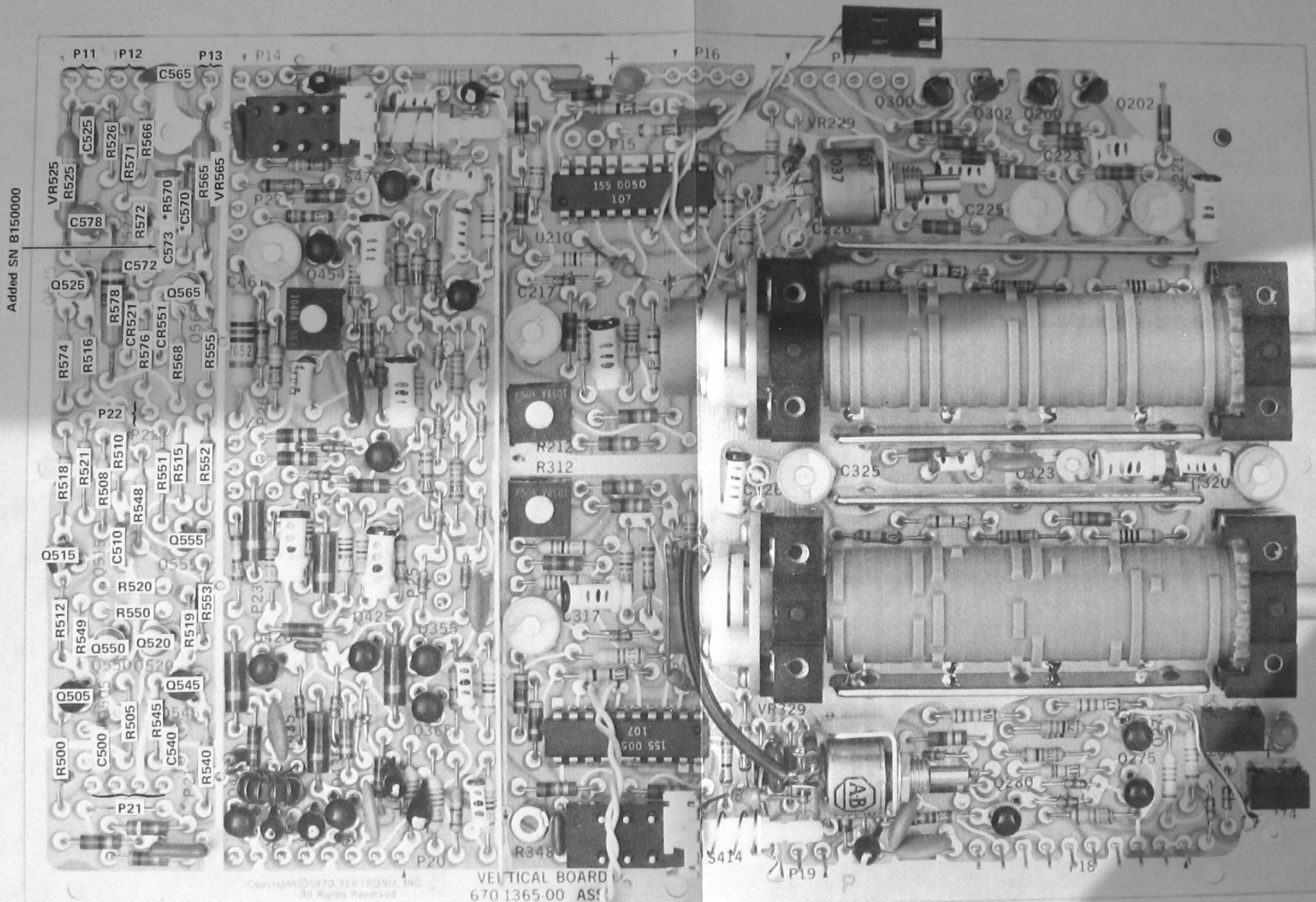

See Figs. 8-3, 8-6, 8-7, and 8-10 for location of components not identified here.

*C570 & *R570 locations reversed SN B180000

Fig. 8-9. P/O A2. Partial Vertical circuit board.

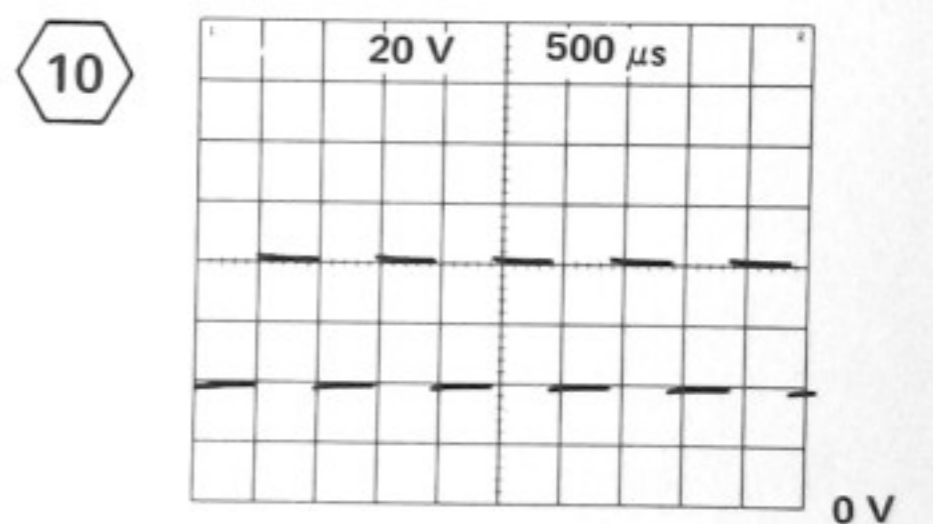
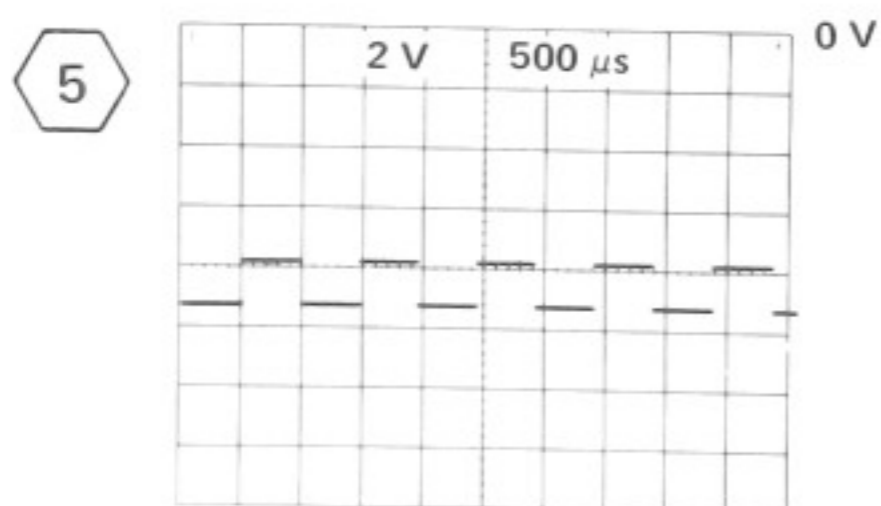
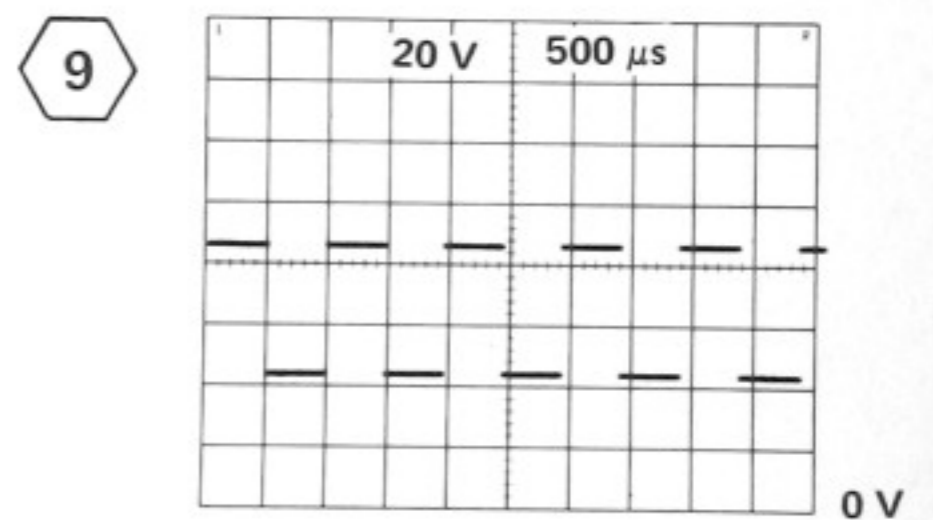
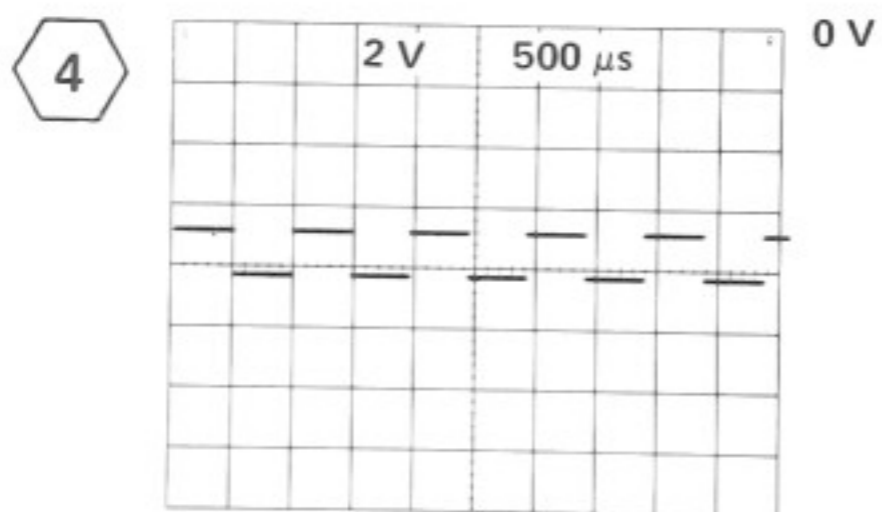
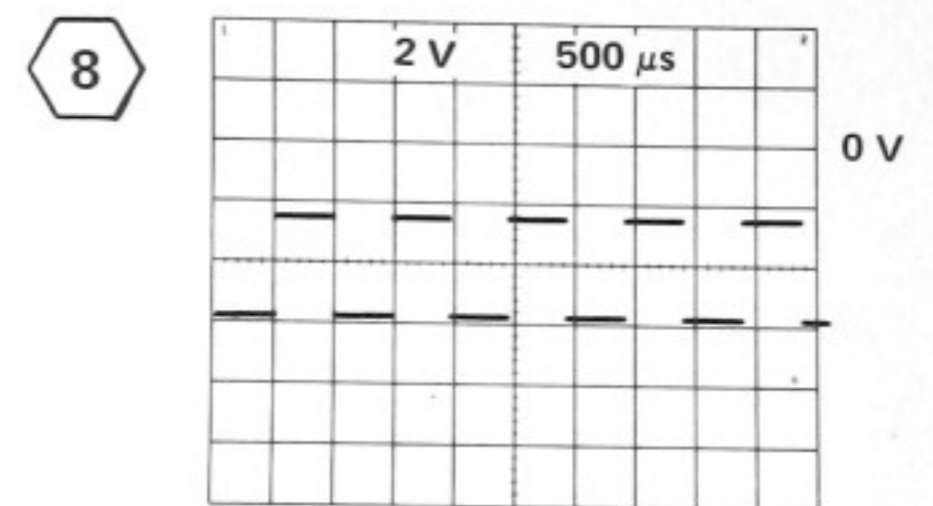
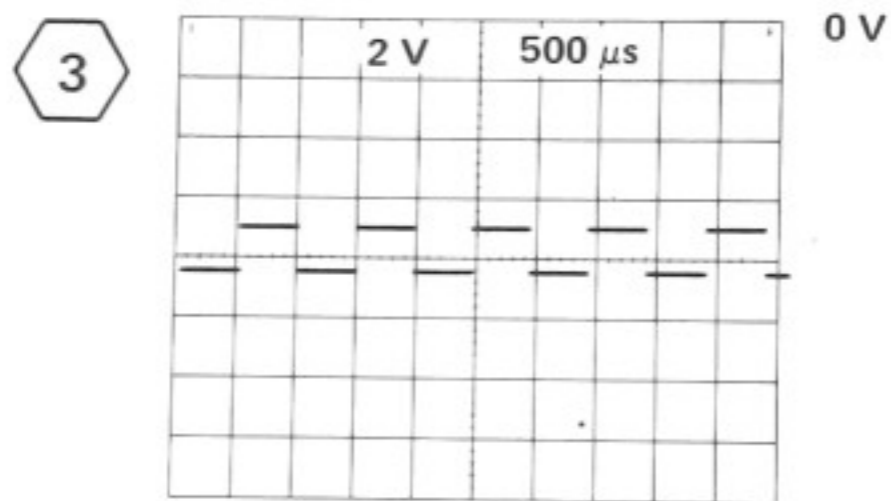
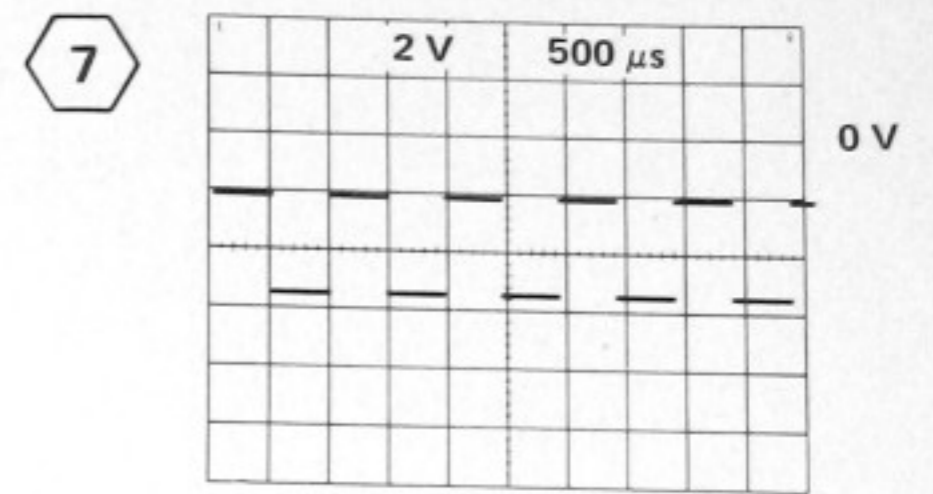
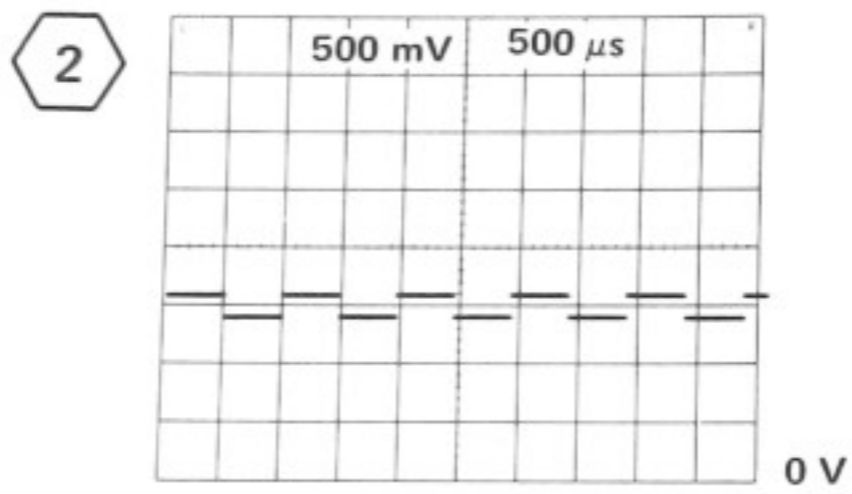
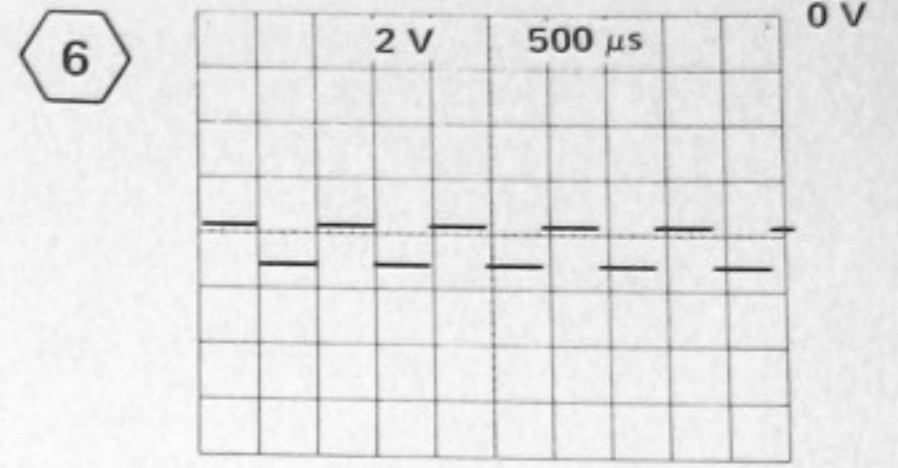
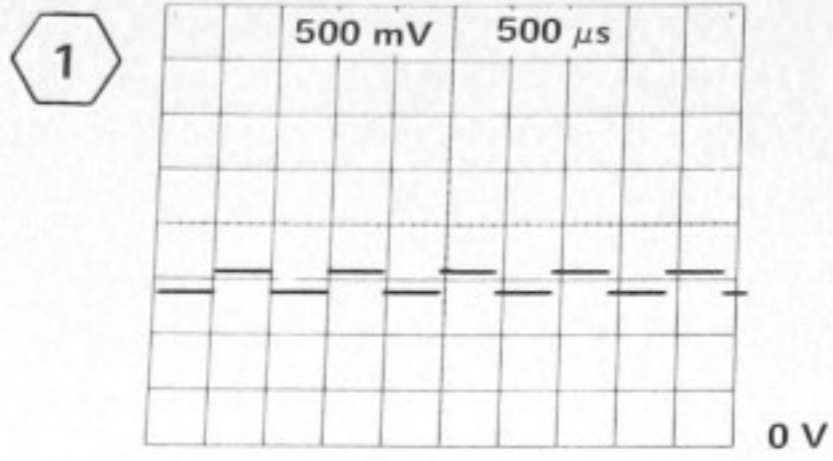

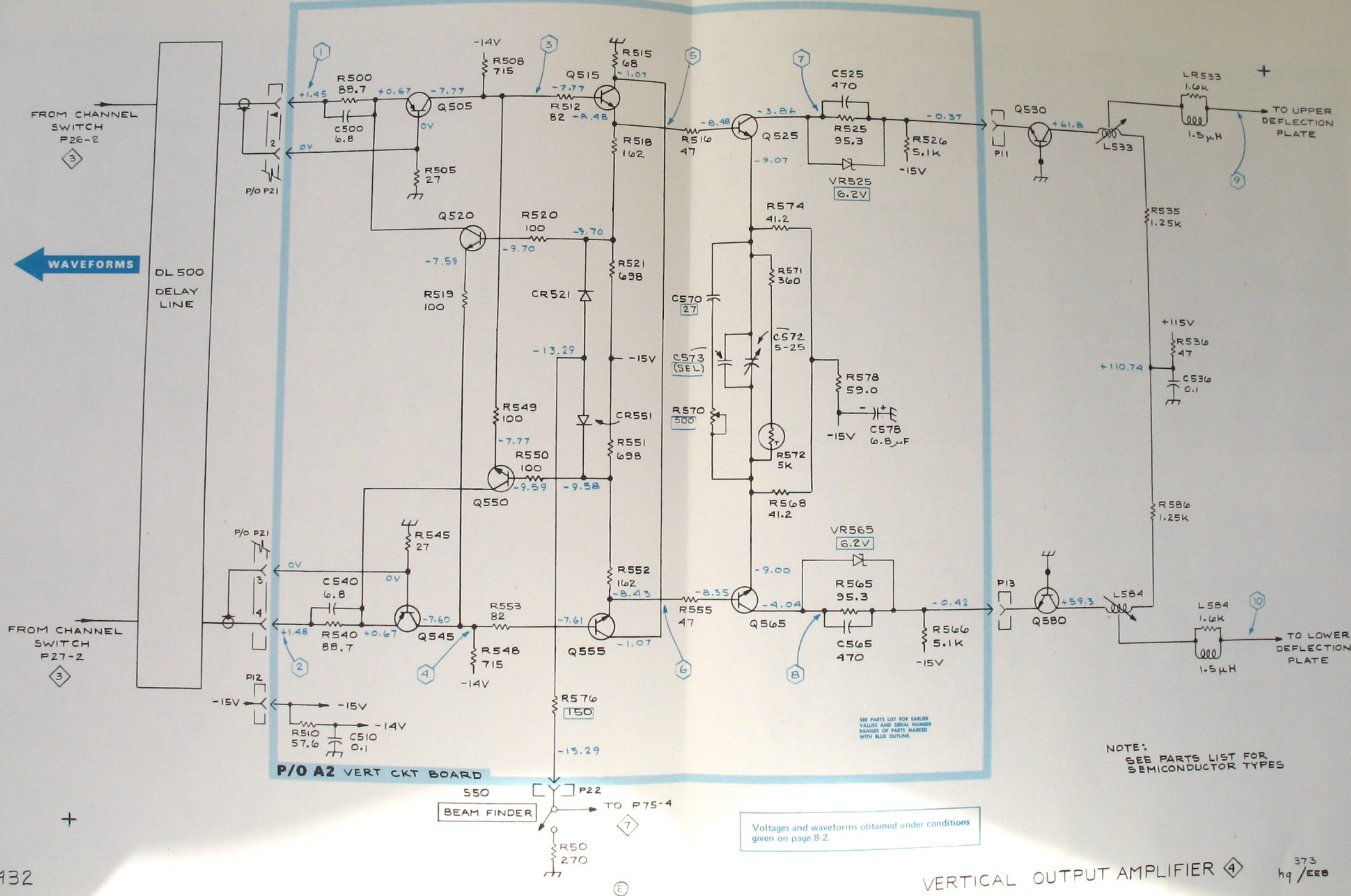

← WAVEFORMS

DL 500
DELAY
LINE

FROM CHANNEL
SWITCH
P27-2

432

10-4-66

P/O A2 VERT CKT BOARD

550 [] P22
BEAM FINDER TO P75-4

Voltages and waveforms obtained under conditions given on page 8-2.

SEE PARTS LIST FOR EARLIER VALUES AND SERIAL NUMBER RANGES OF PARTS MARKED WITH BLUE OUTLINE.

NOTE:
SEE PARTS LIST FOR SEMICONDUCTOR TYPES

VERTICAL OUTPUT AMPLIFIER 4

373
hq/EEB

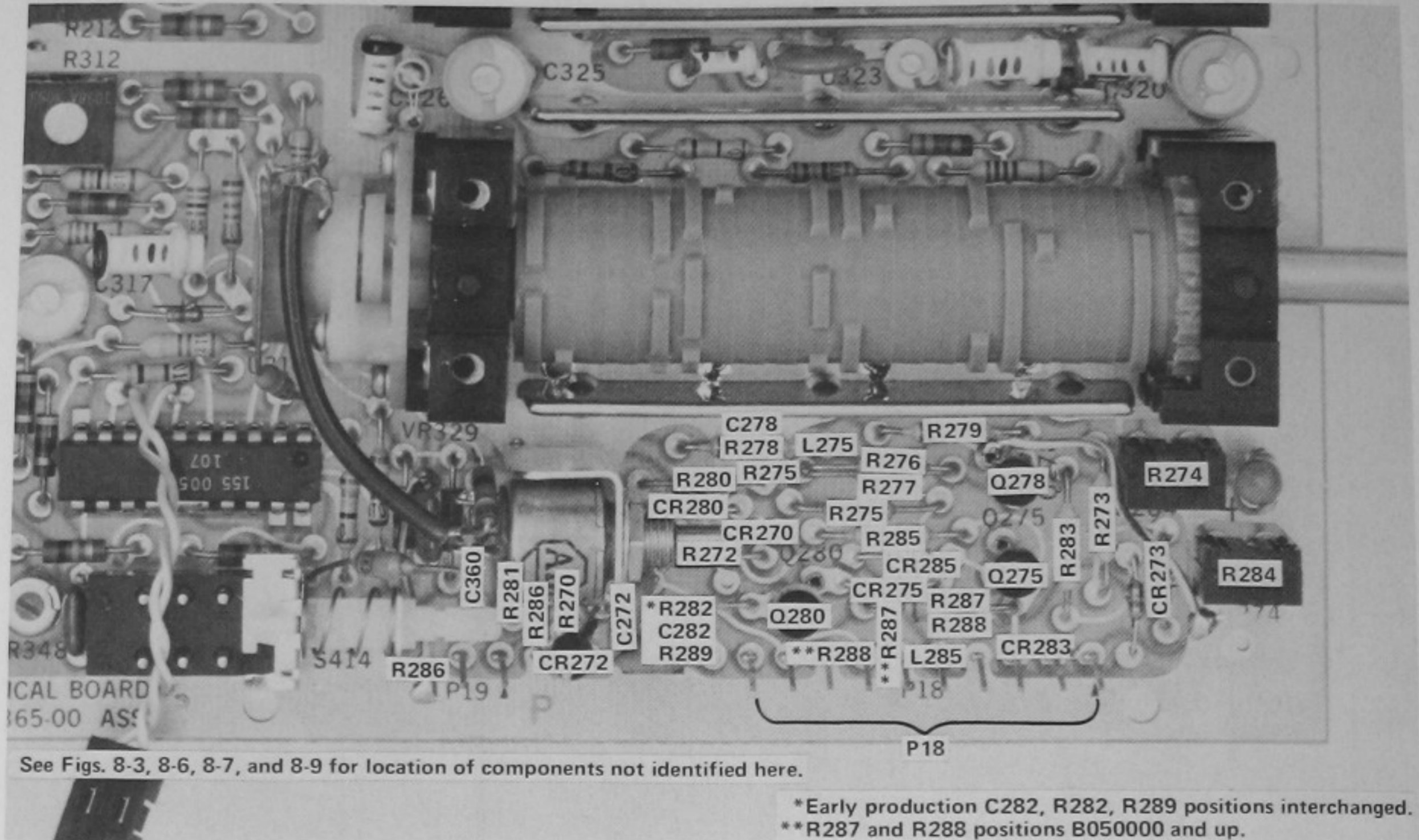

Fig. 8-10. P/O A2. Partial Vertical circuit board. ©

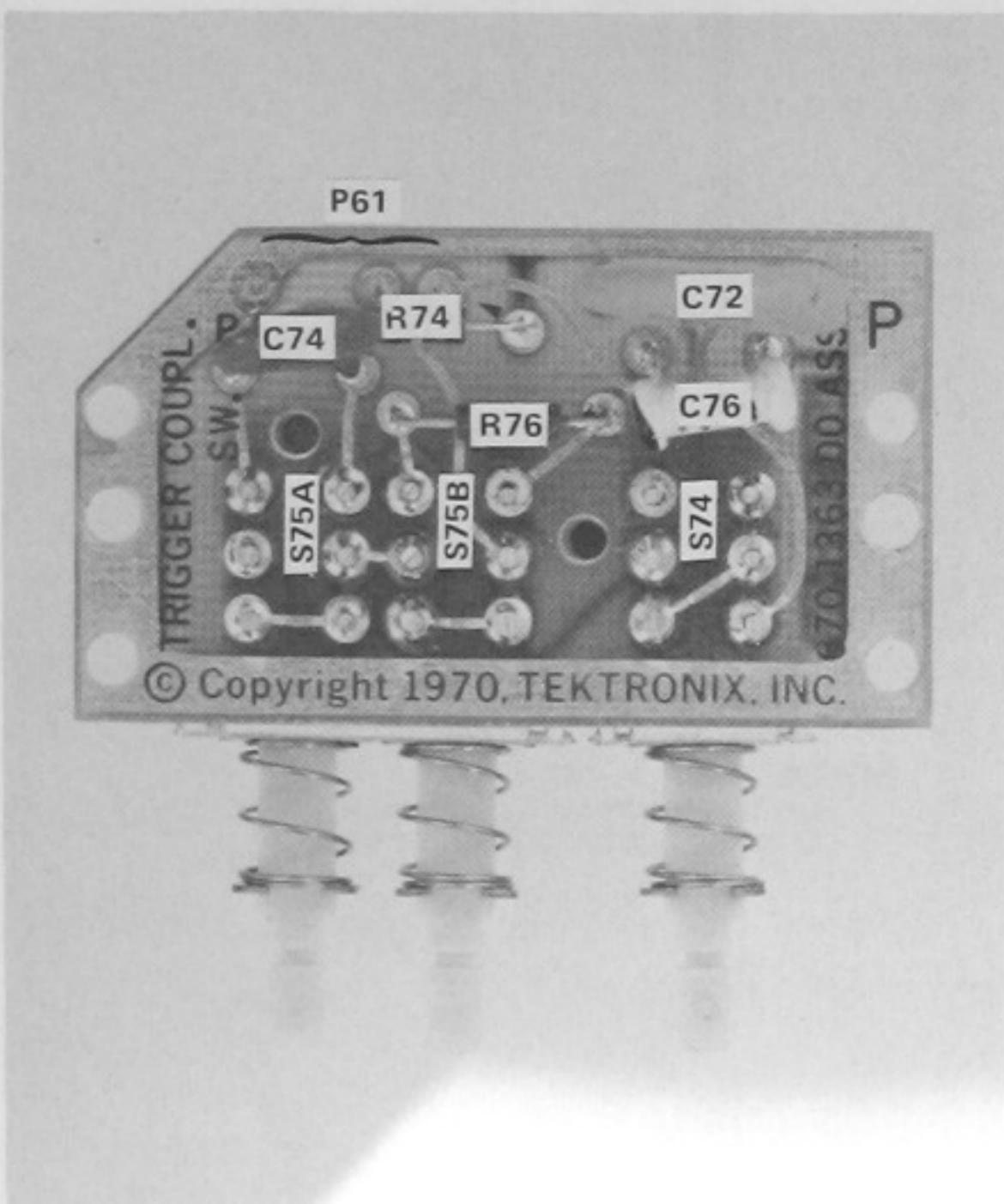

Fig. 8-11. A7. Trigger Coupling Switch Circuit board. ©

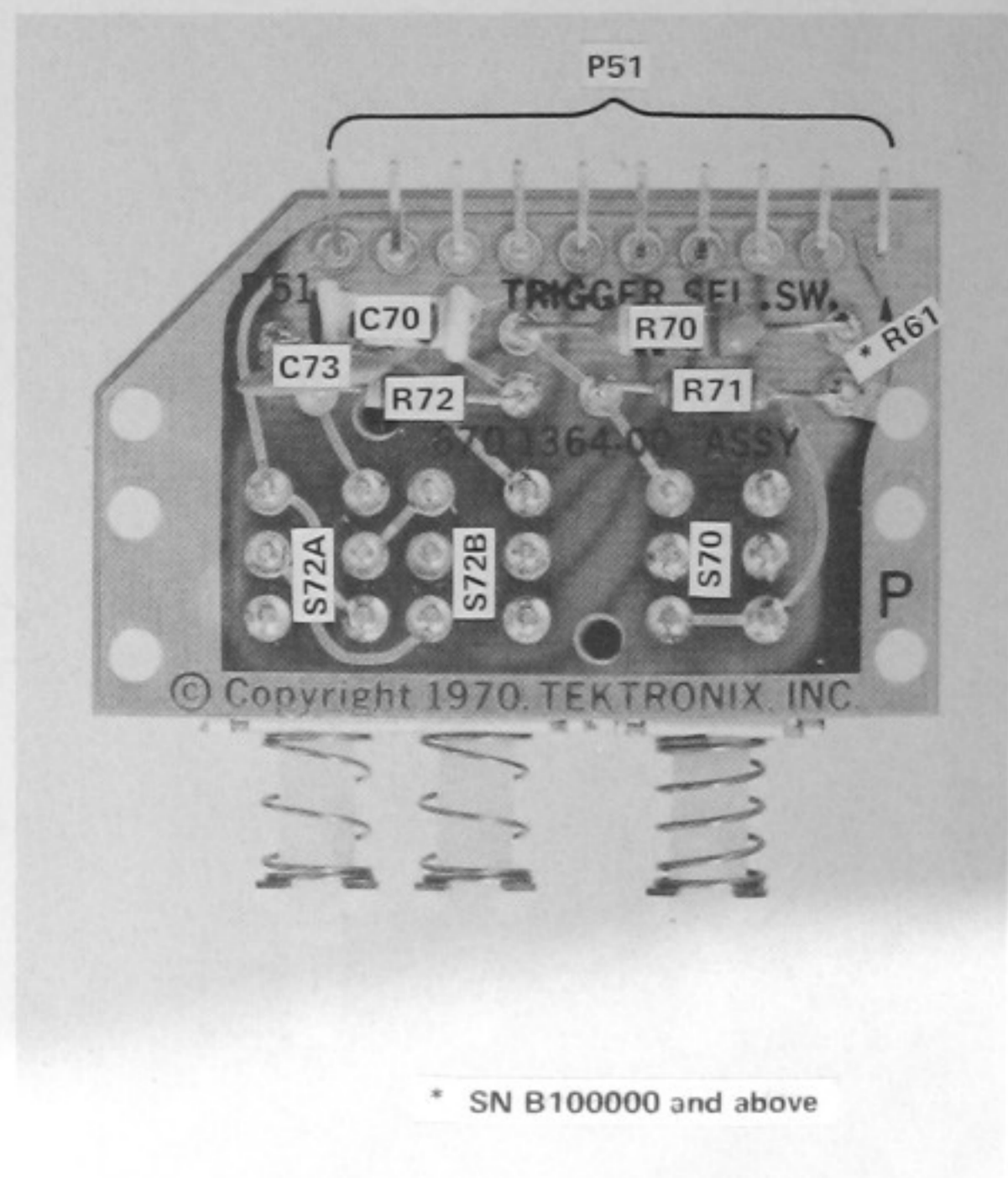
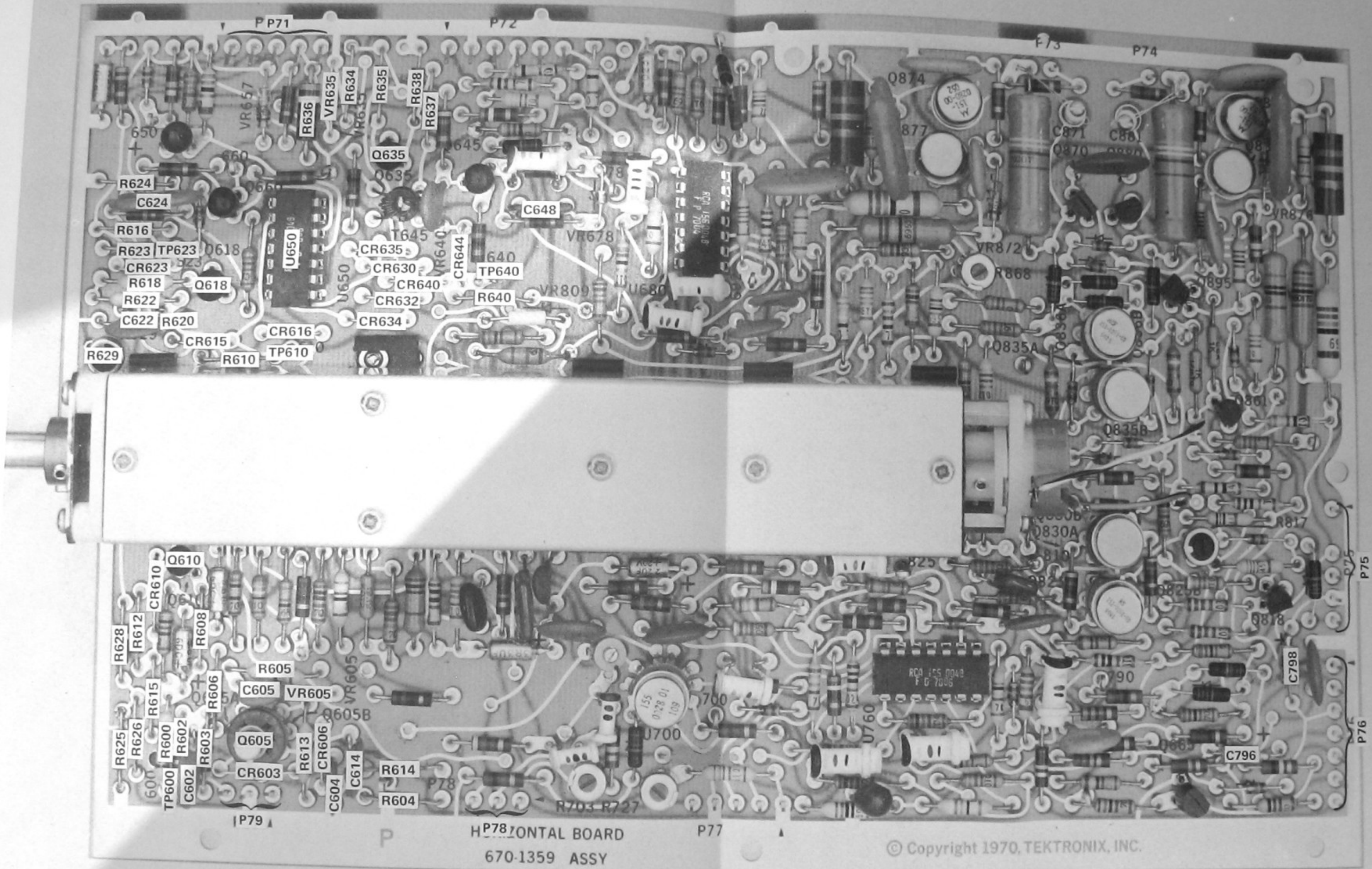
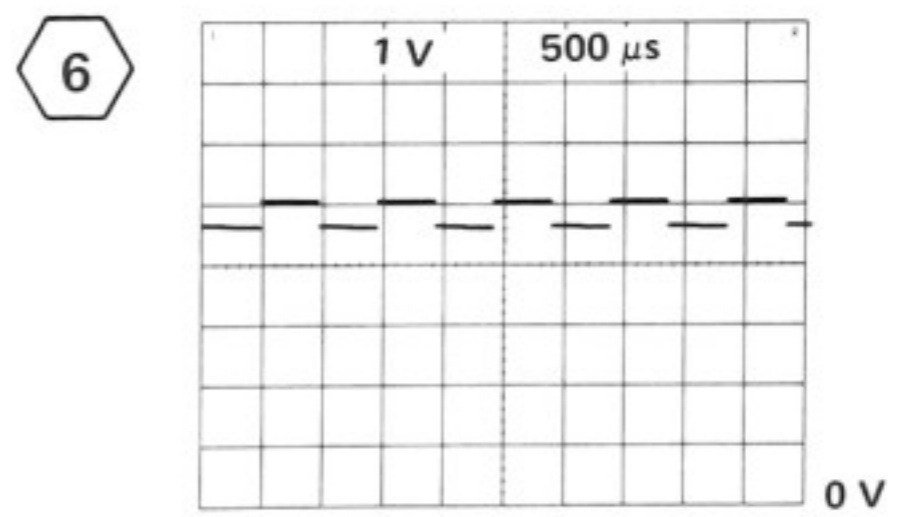
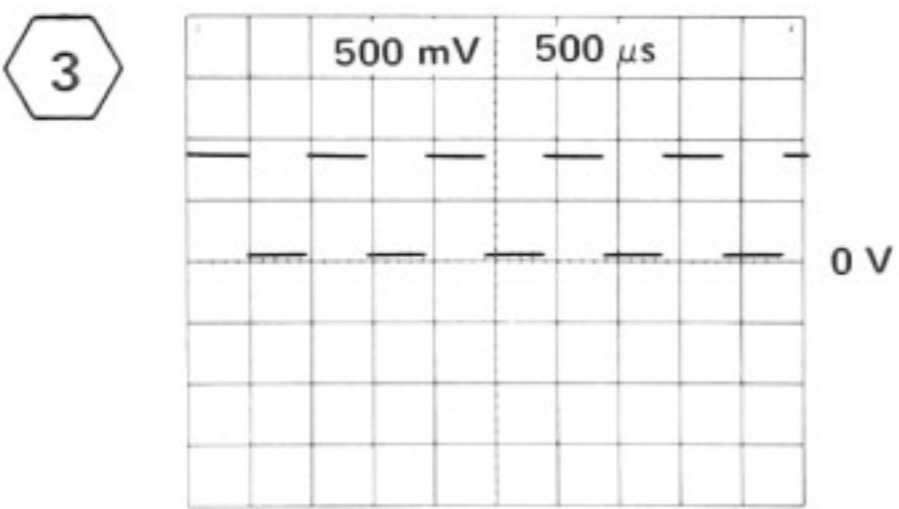
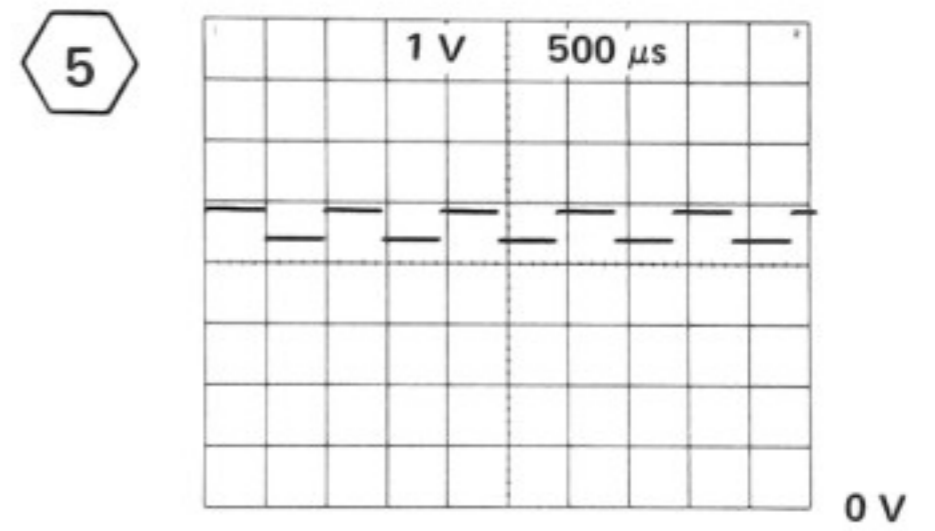
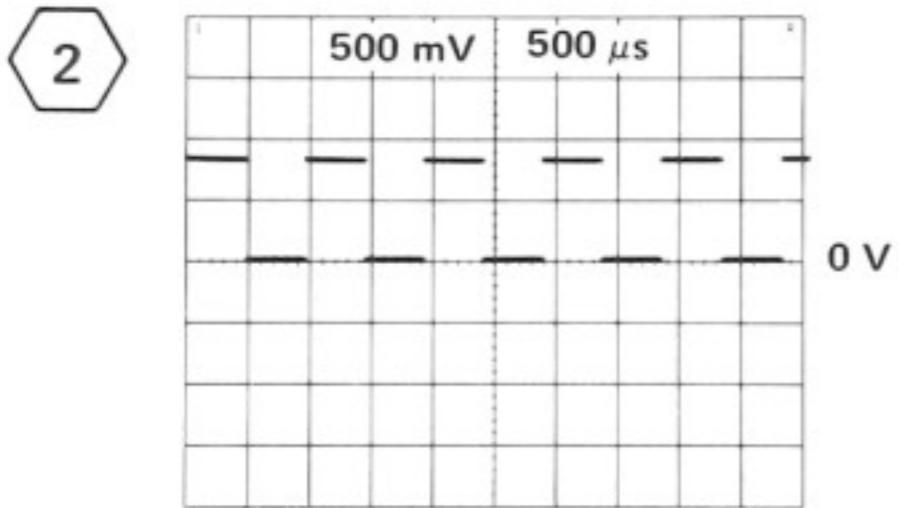
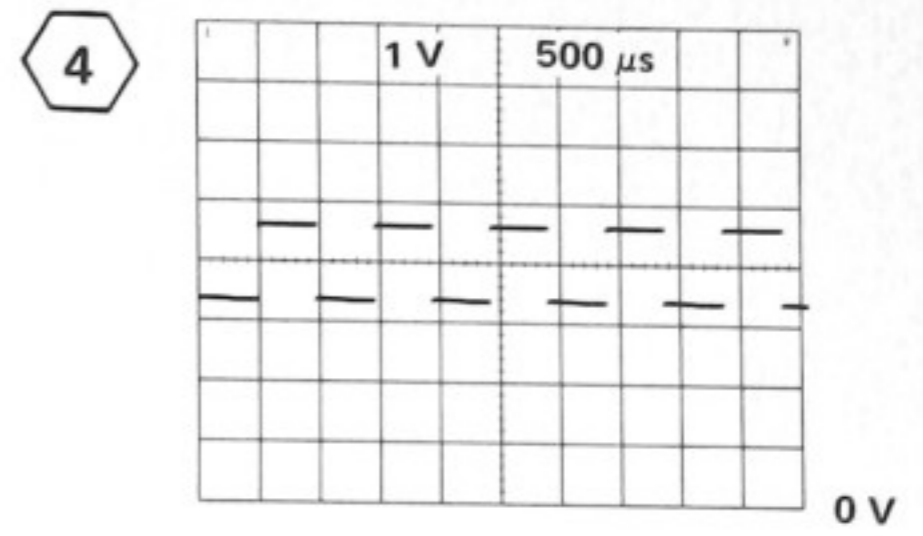
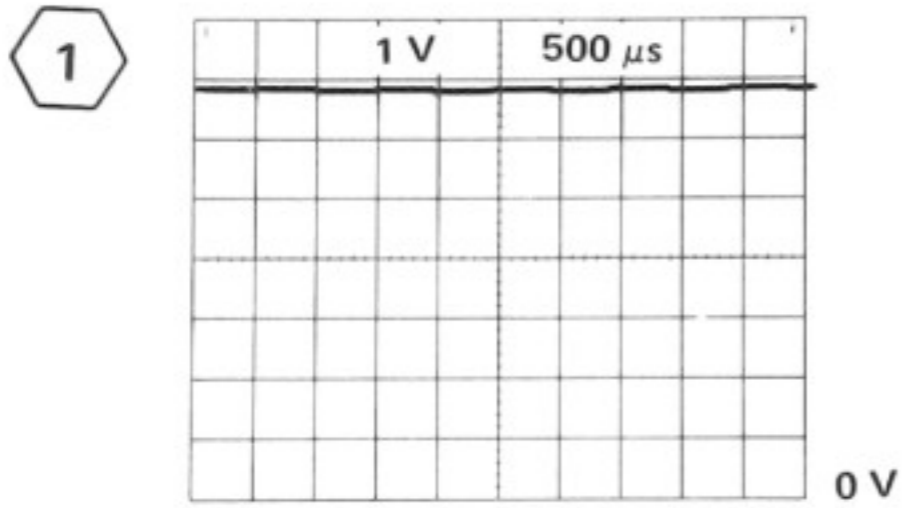

Fig. 8-12. A6. Trigger Source Switch circuit board. ©



See Figs. 8-14, 8-15, and 8-16 for location of components not identified here.

Fig. 8-13. P/O A8. Partial Horizontal circuit board.



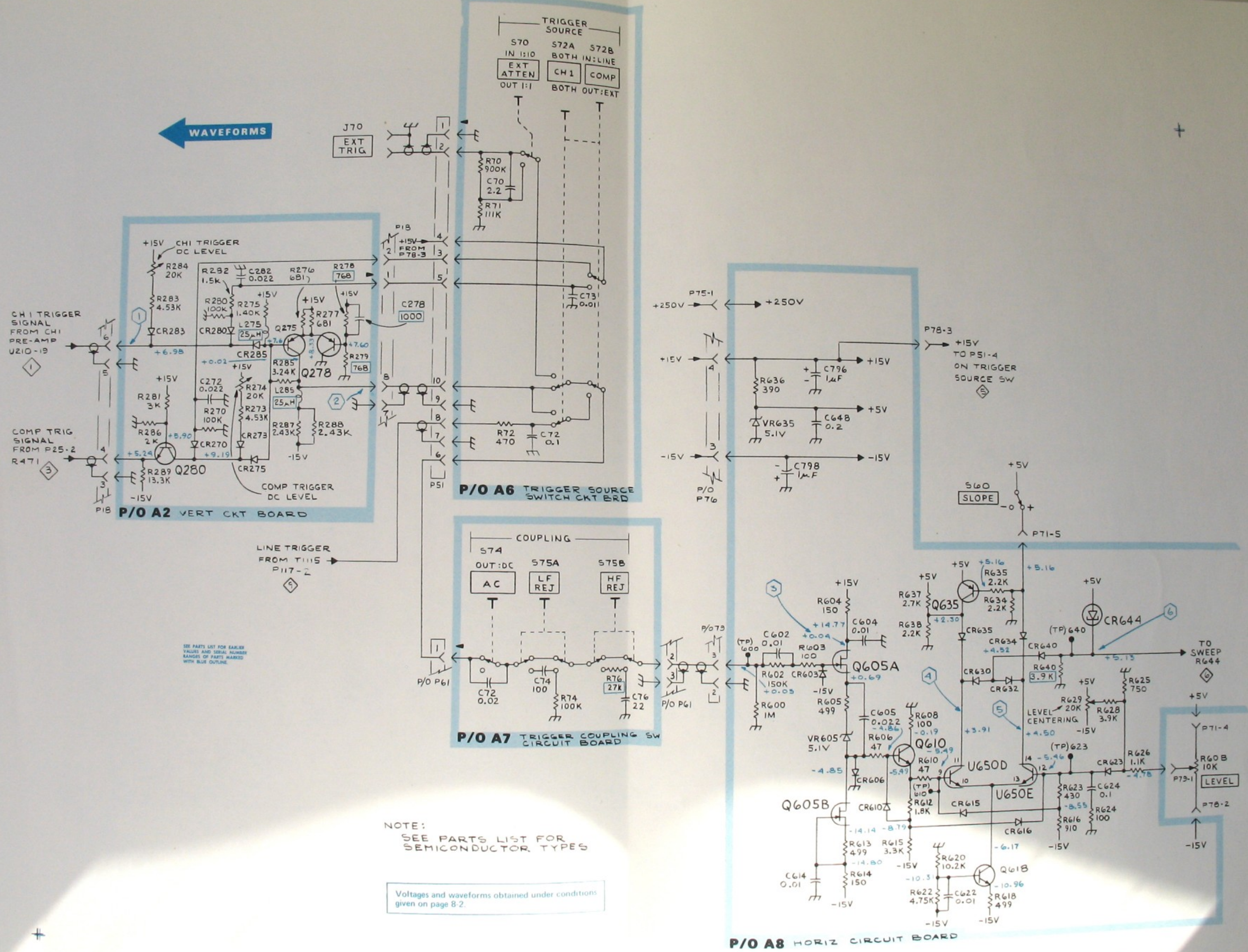

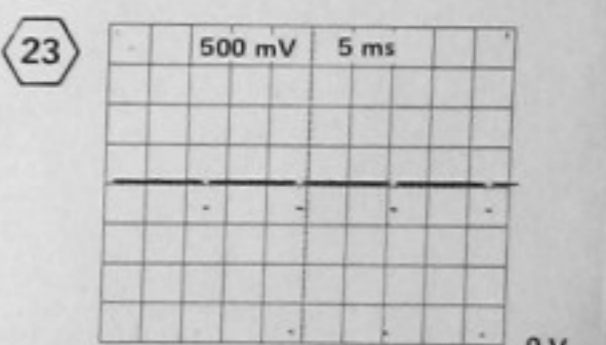
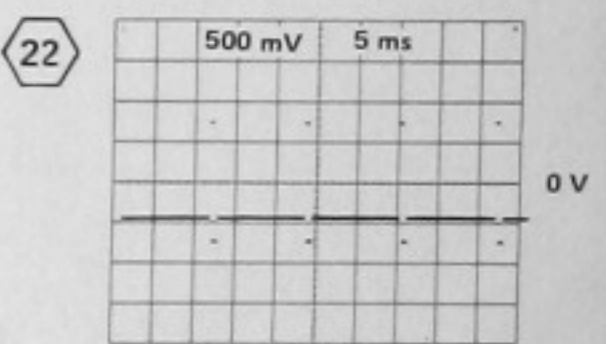
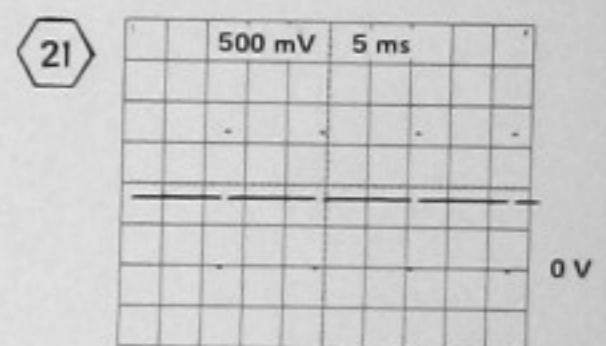
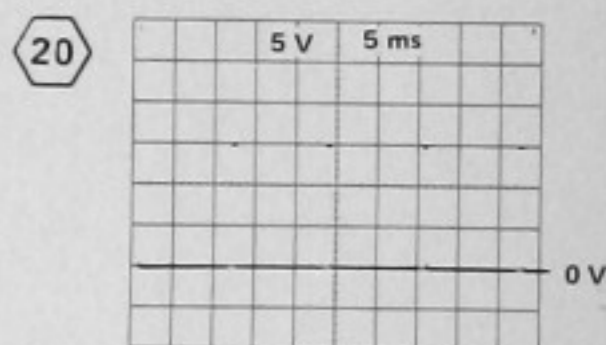
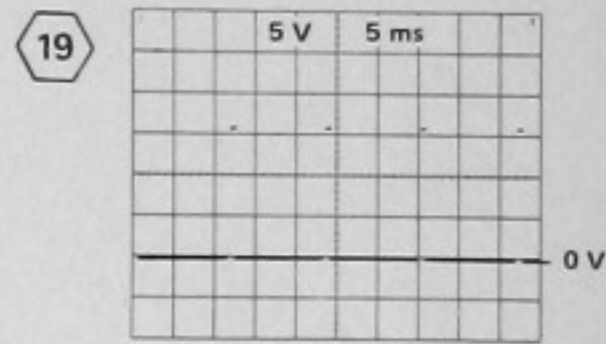
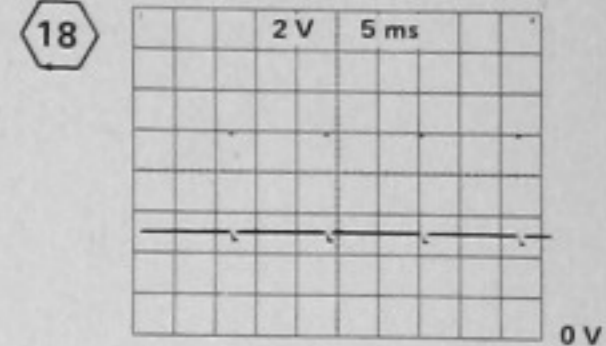
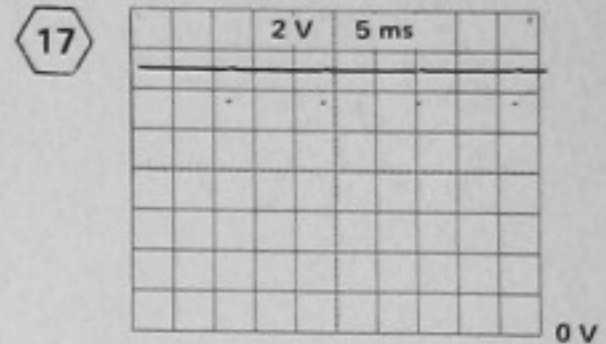
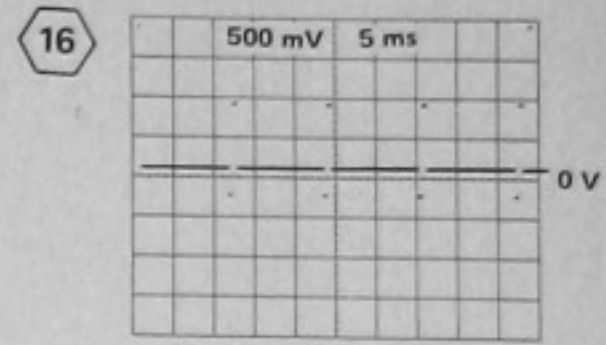
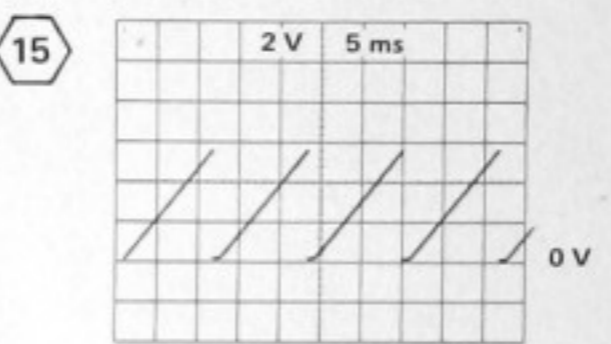
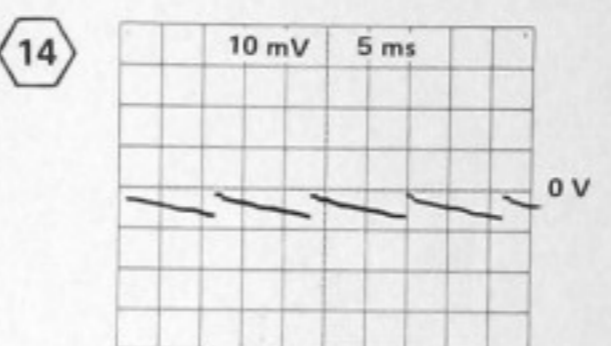
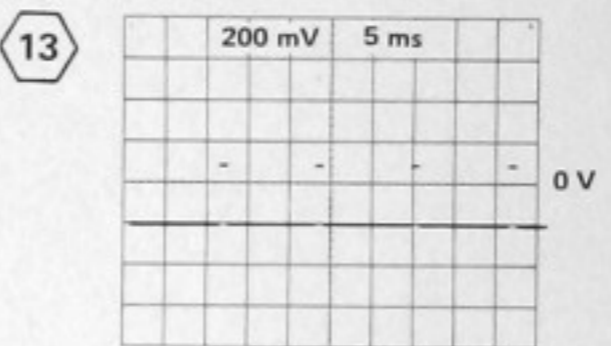
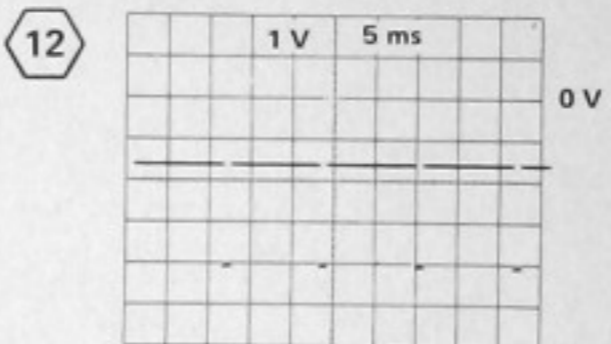
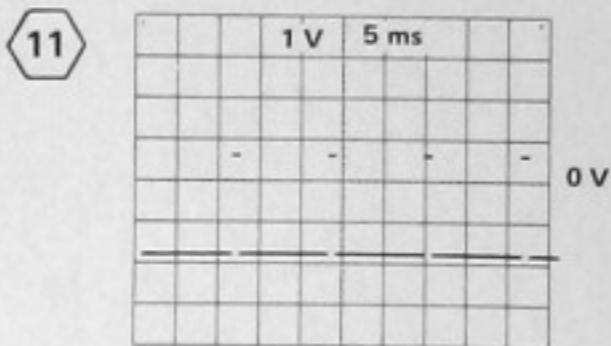
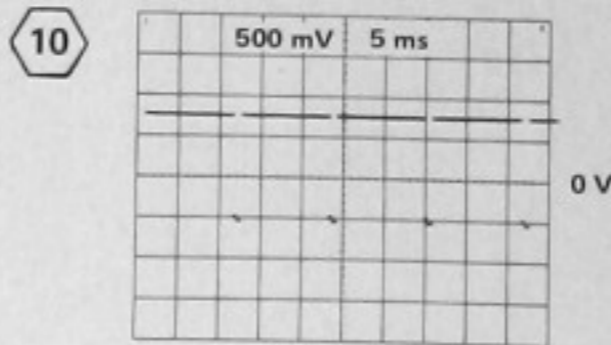
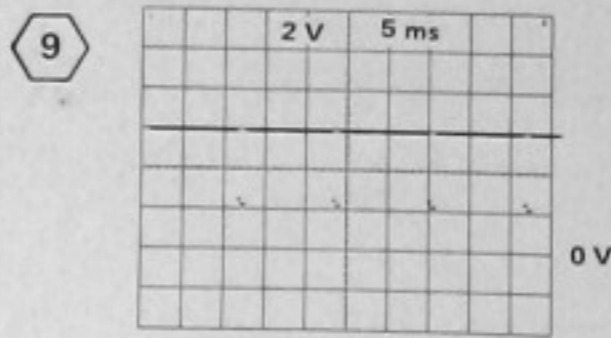
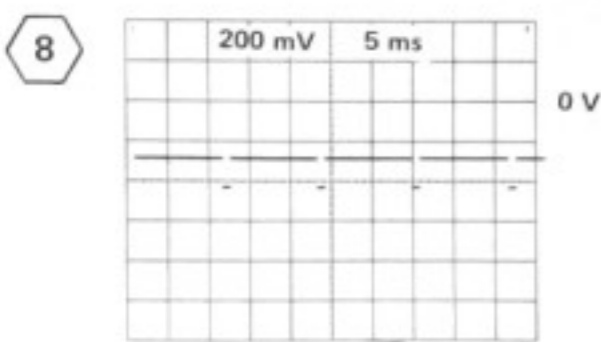
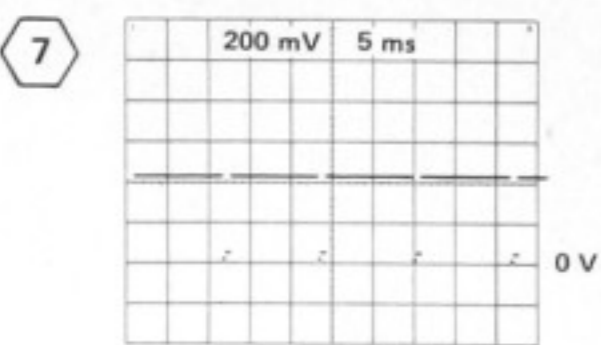
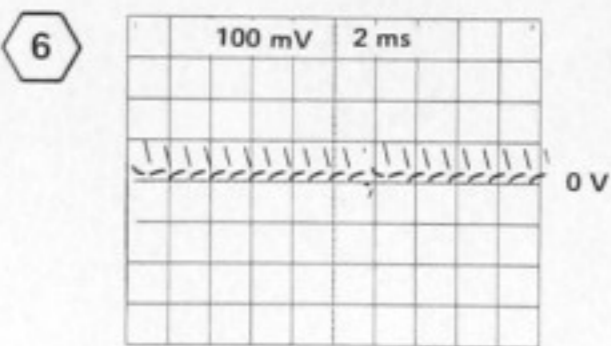
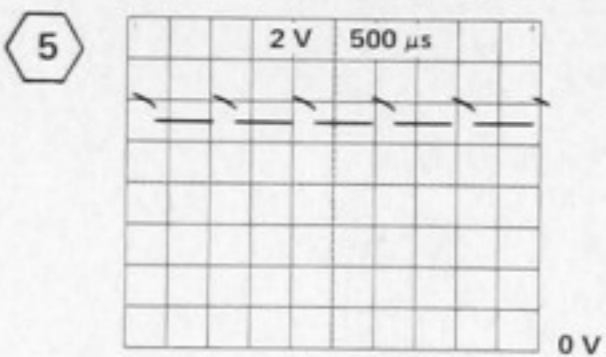
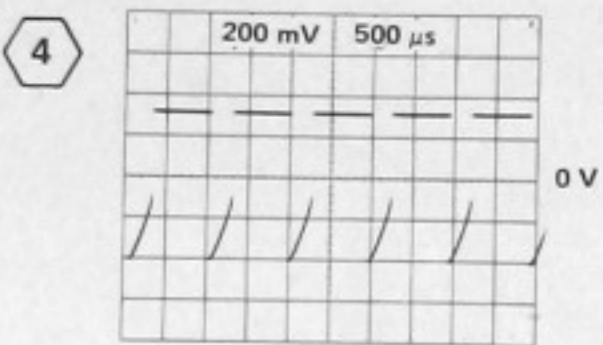
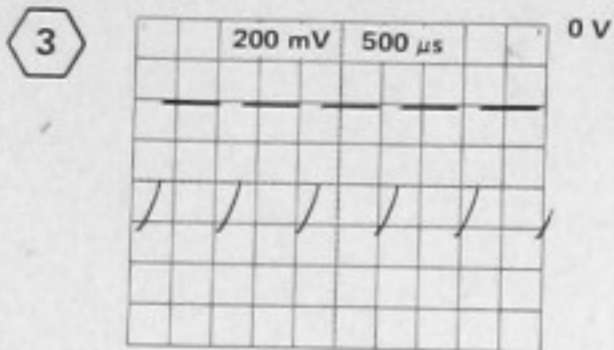
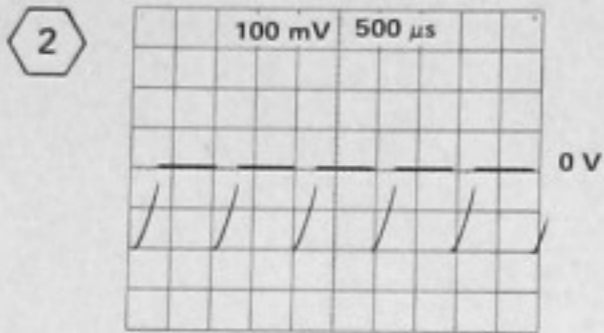
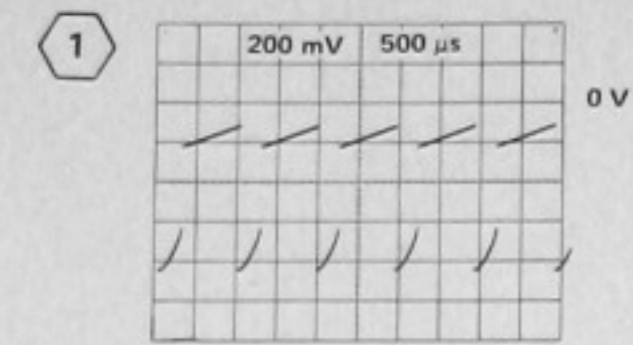

← WAVEFORMS

565	
MODE	
BOTH IN SINGLE	
NORM	AUTO

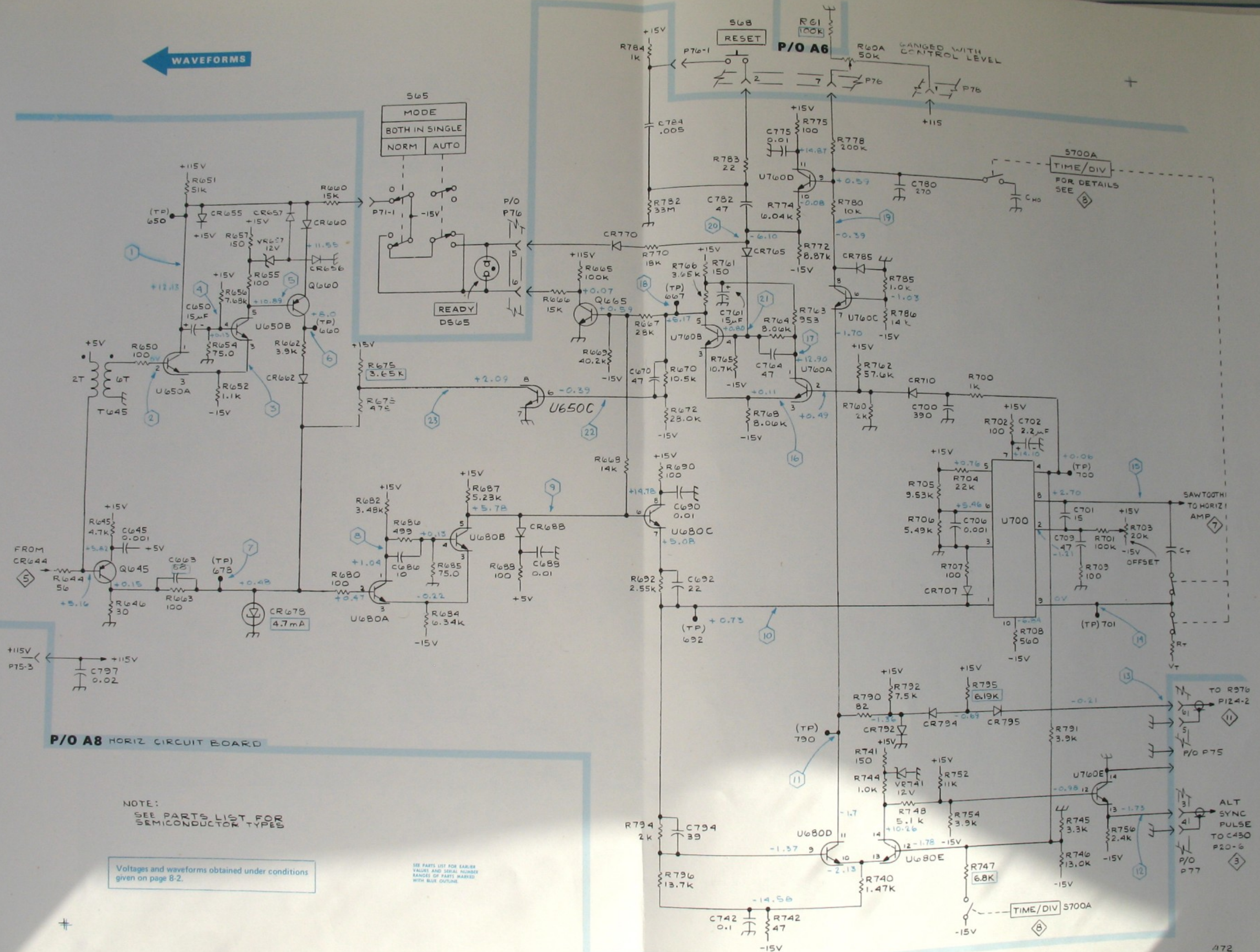

P/O A8 HORIZ CIRCUIT BOARD

NOTE: SEE PARTS LIST FOR SEMICONDUCTOR TYPES

Voltages and waveforms obtained under conditions given on page 8-2.

SEE PARTS LIST FOR EARLIER VALUES AND SERIAL NUMBER RANGES OF PARTS MARKED WITH BLUE OUTLINE

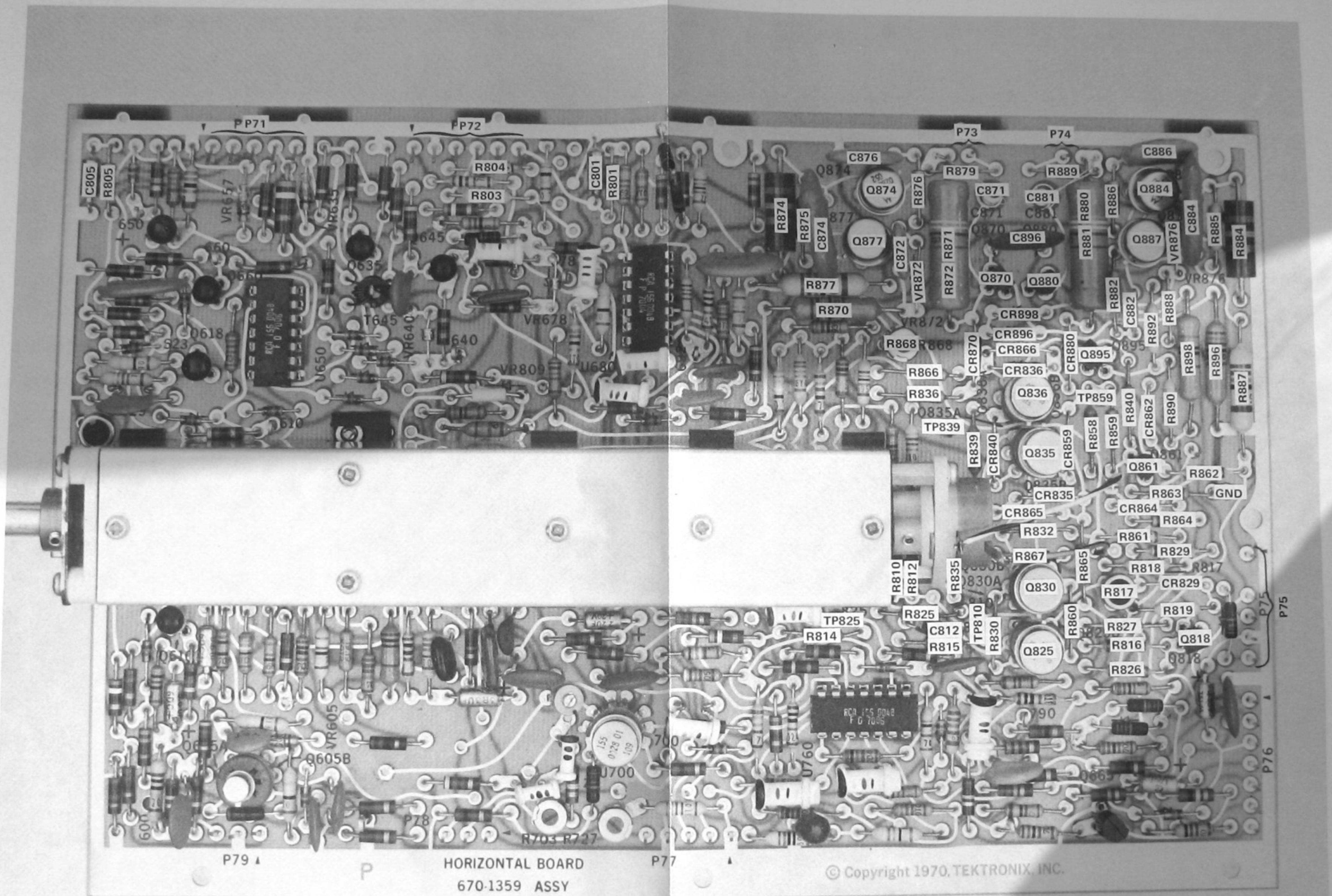

See Figs. 8-13, 8-14, and 8-16 for location of components not identified here.

Fig. 8-15. P/O A8. Partial Horizontal circuit board.

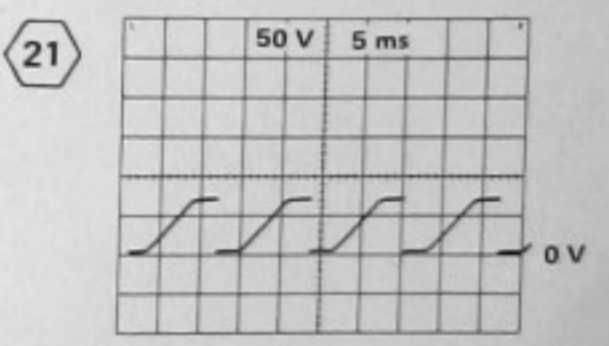
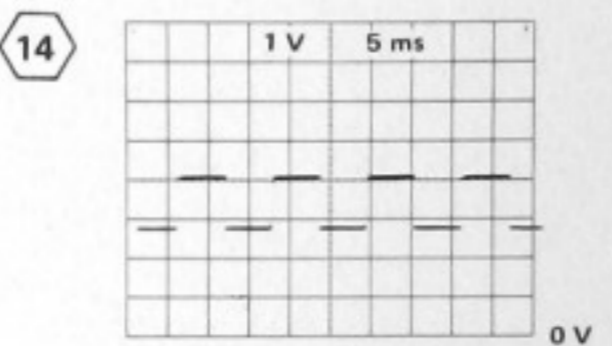
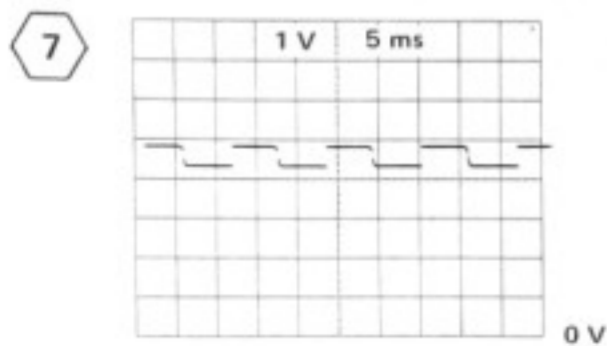
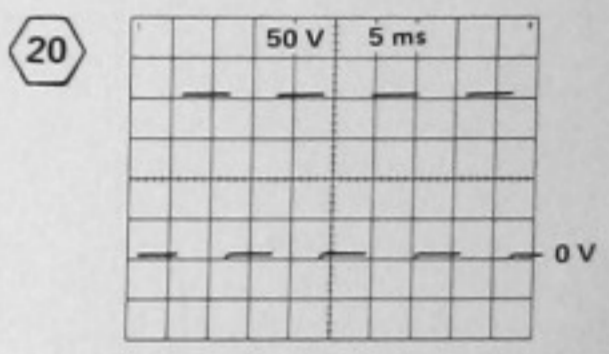
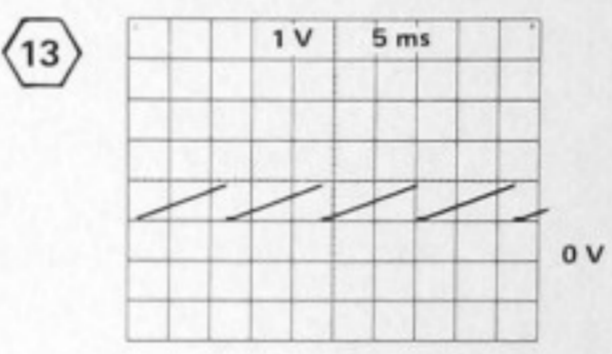
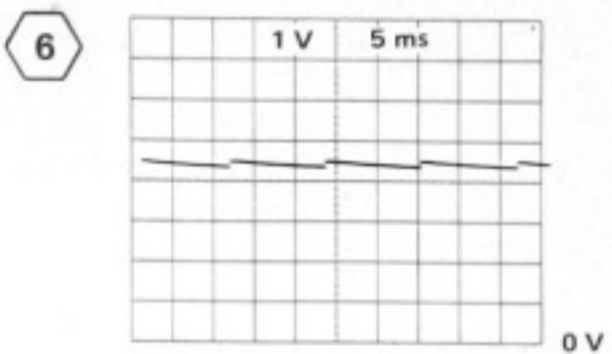
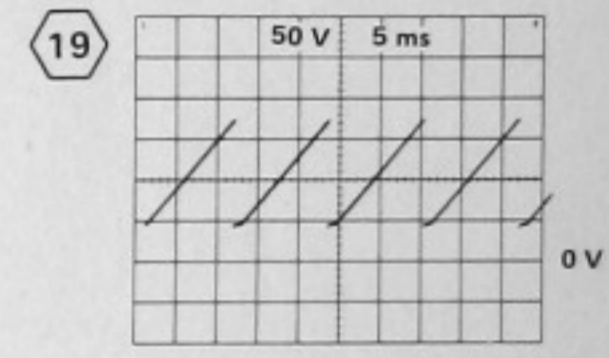
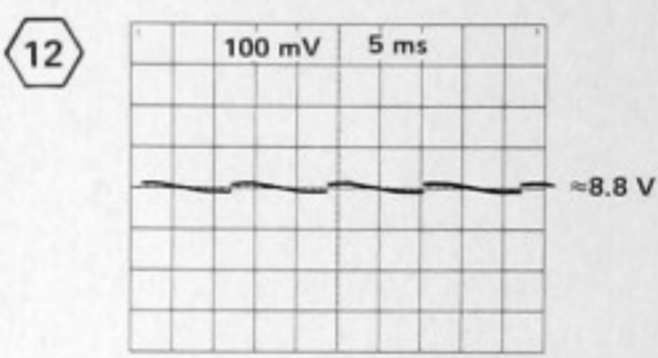
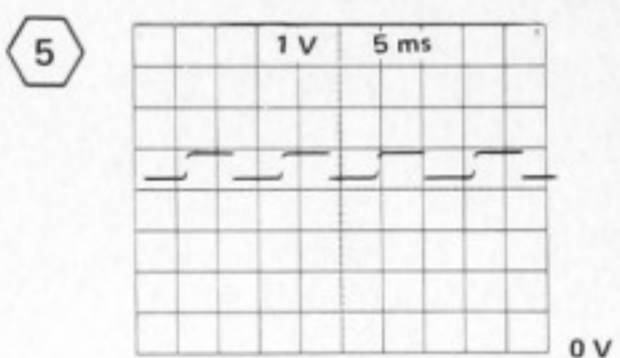
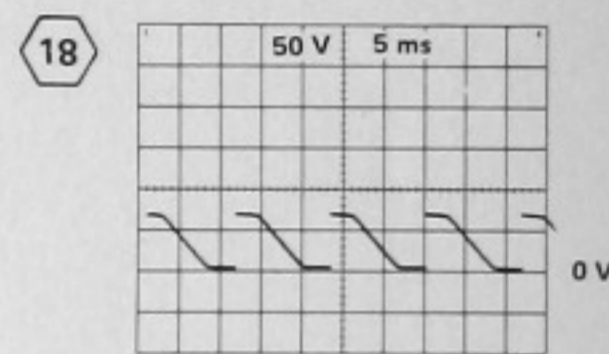
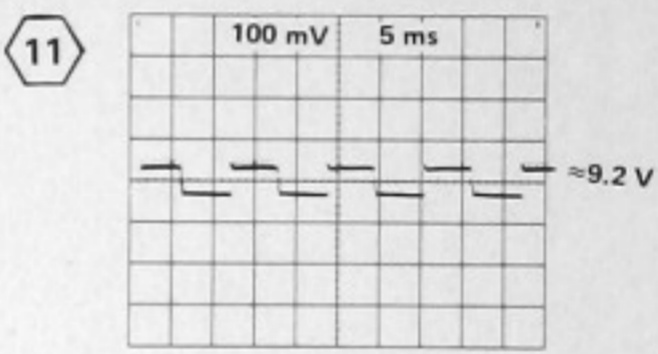
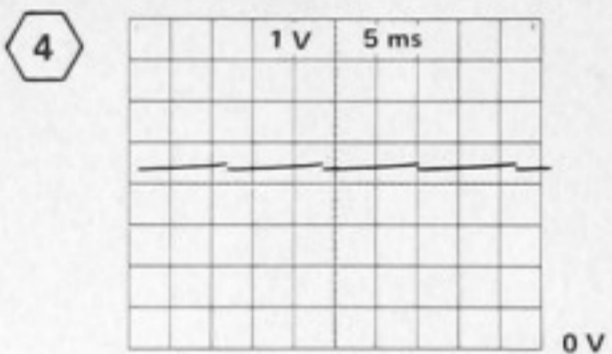
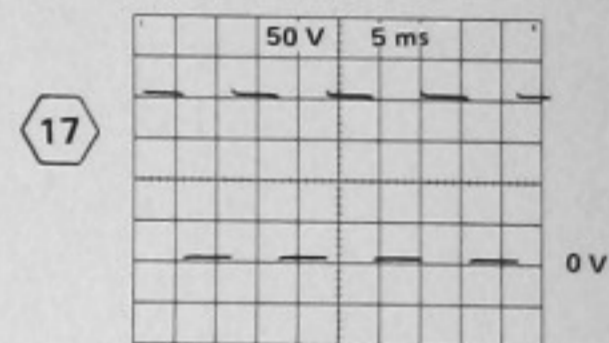
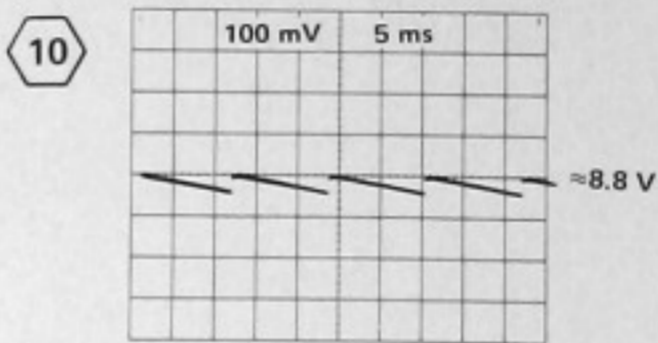
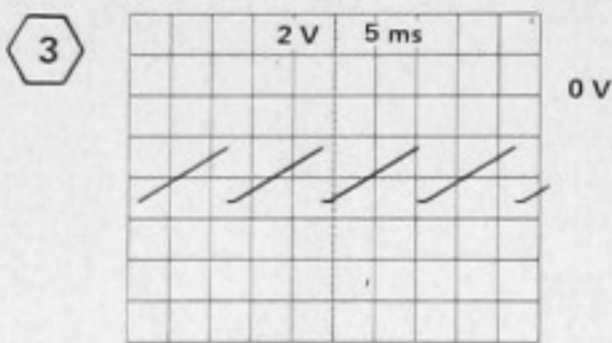
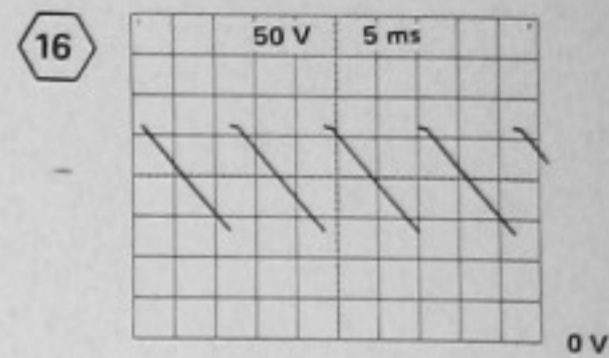
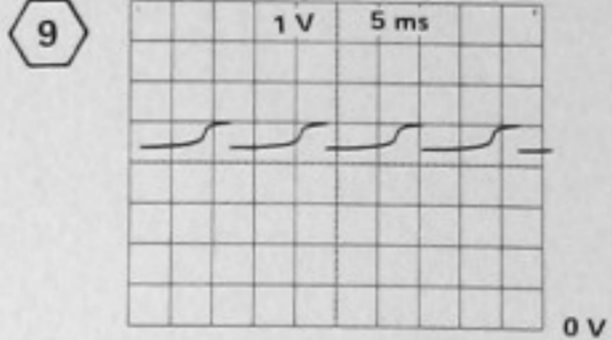
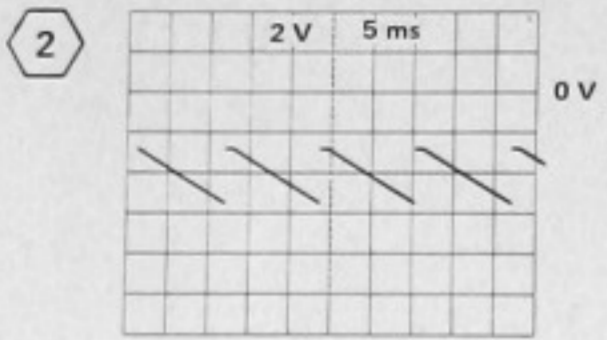
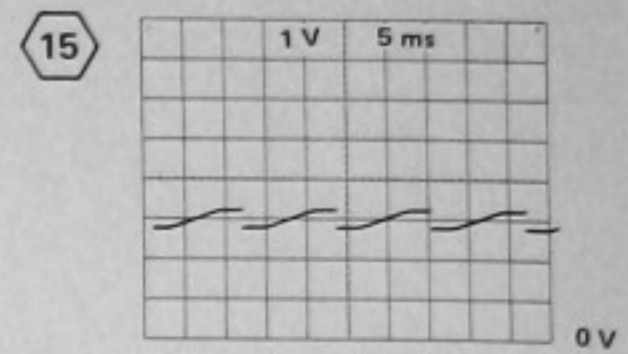
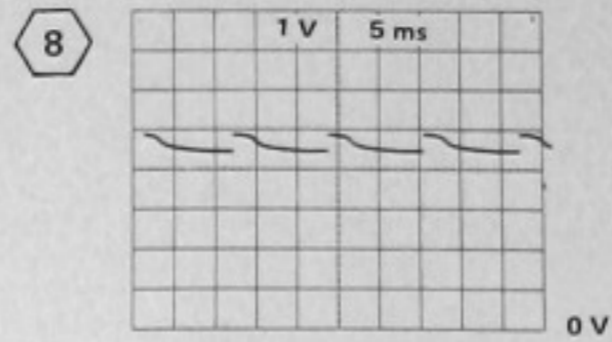
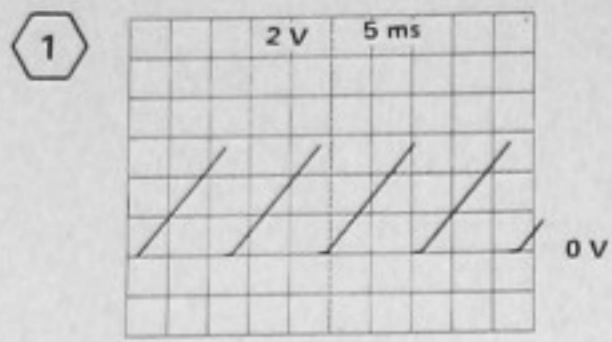

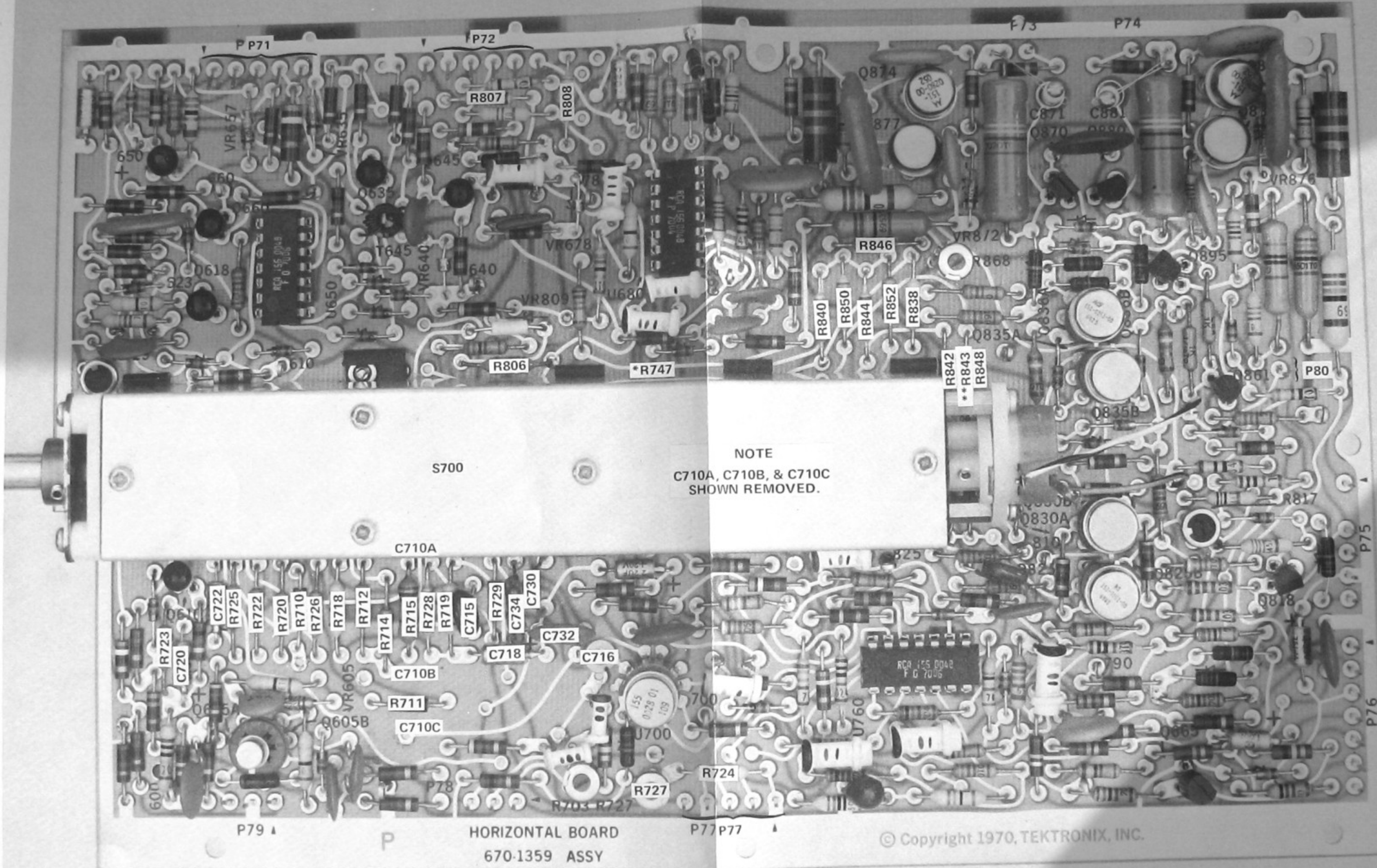

NOTE
C710A, C710B, & C710C
SHOWN REMOVED.

See Figs. 8-13, 8-14, and 8-15 for location of components not identified here.

- *B050000 and up
- **Added SN B160000

Fig. 8-16. P/O A8. Partial Horizontal circuit board.

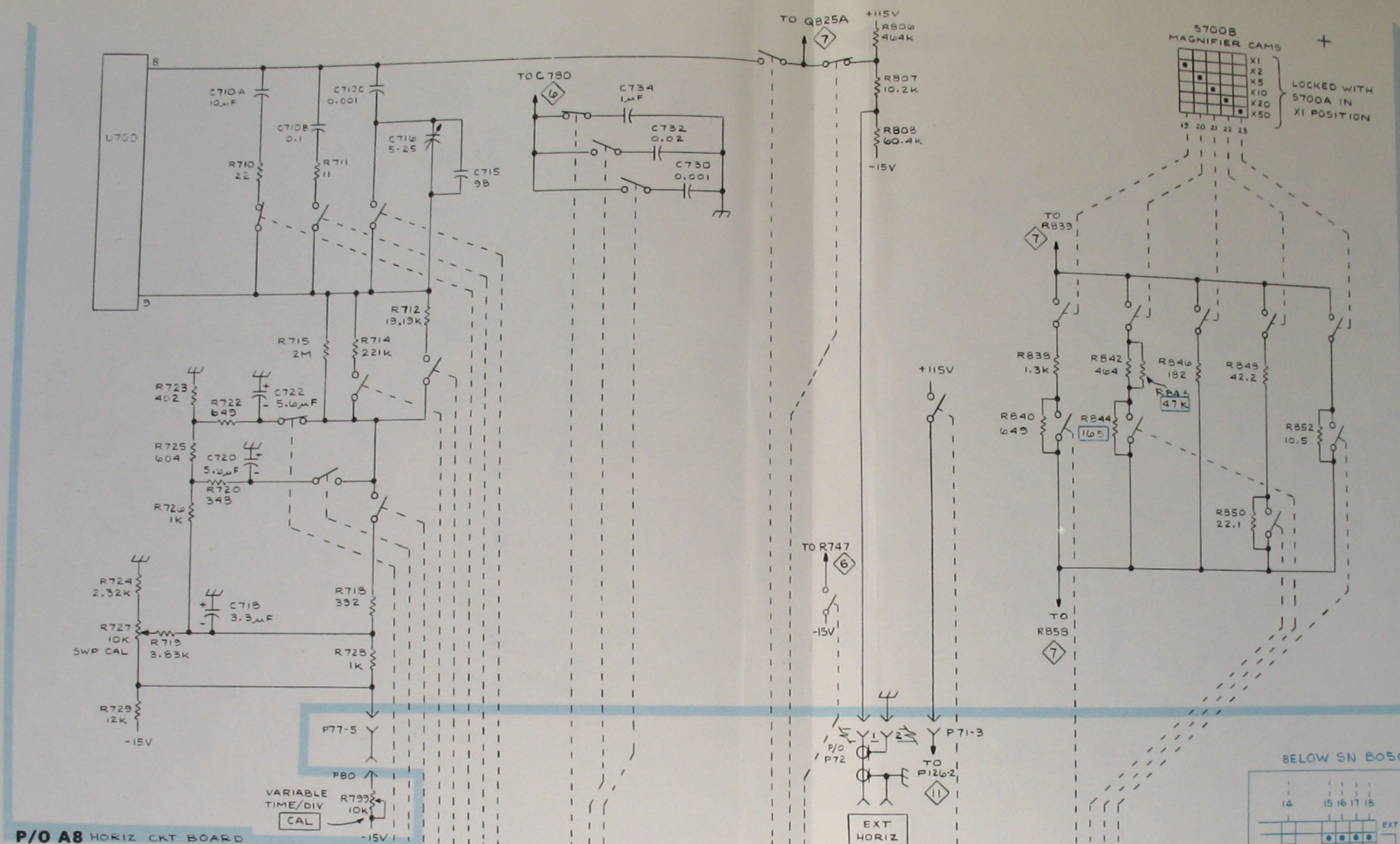

P/O A8 HORIZ CKT BOARD

SEE PARTS LIST FOR EARLIER VALUES AND SERIAL NUMBER RANGES OF PARTS MARKED WITH BLUE OUTLINE

5700A
TIME/DIV

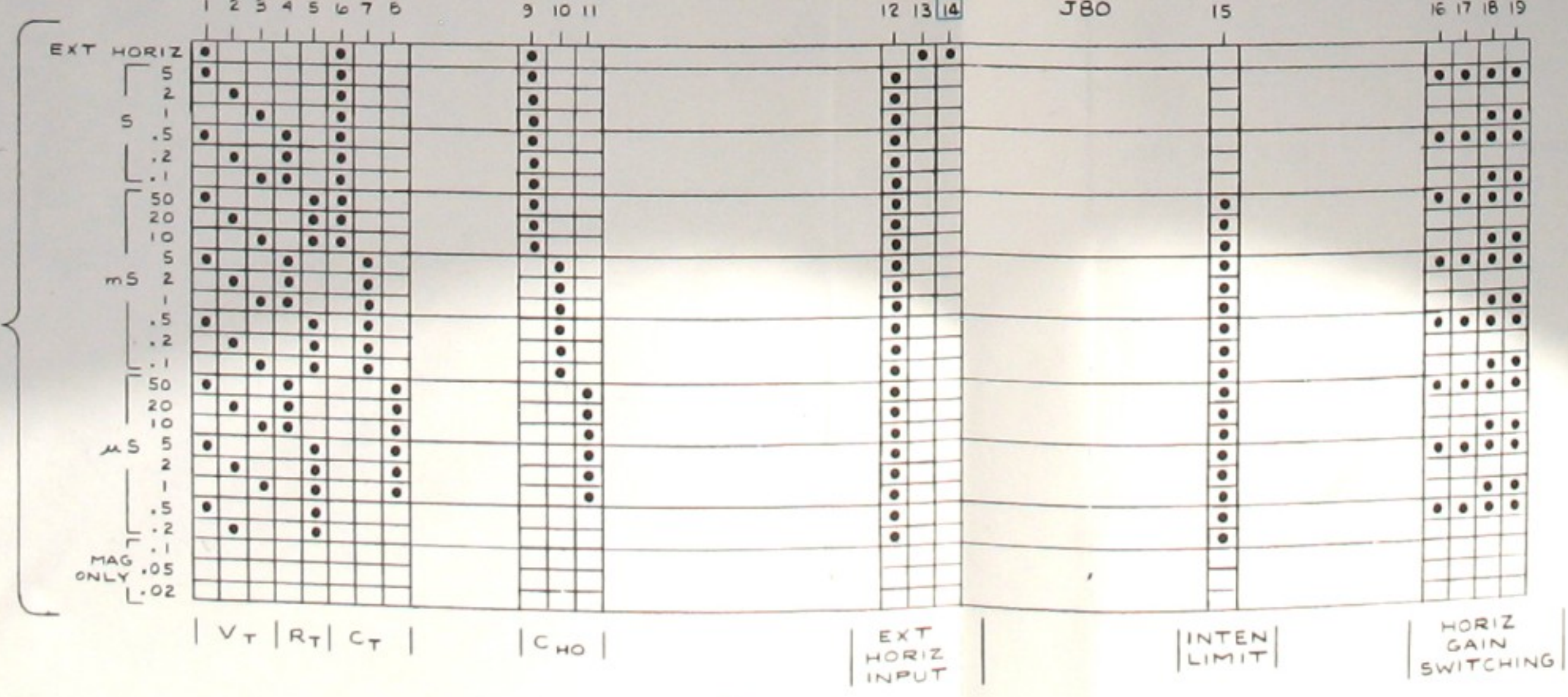

BELOW SN B050000

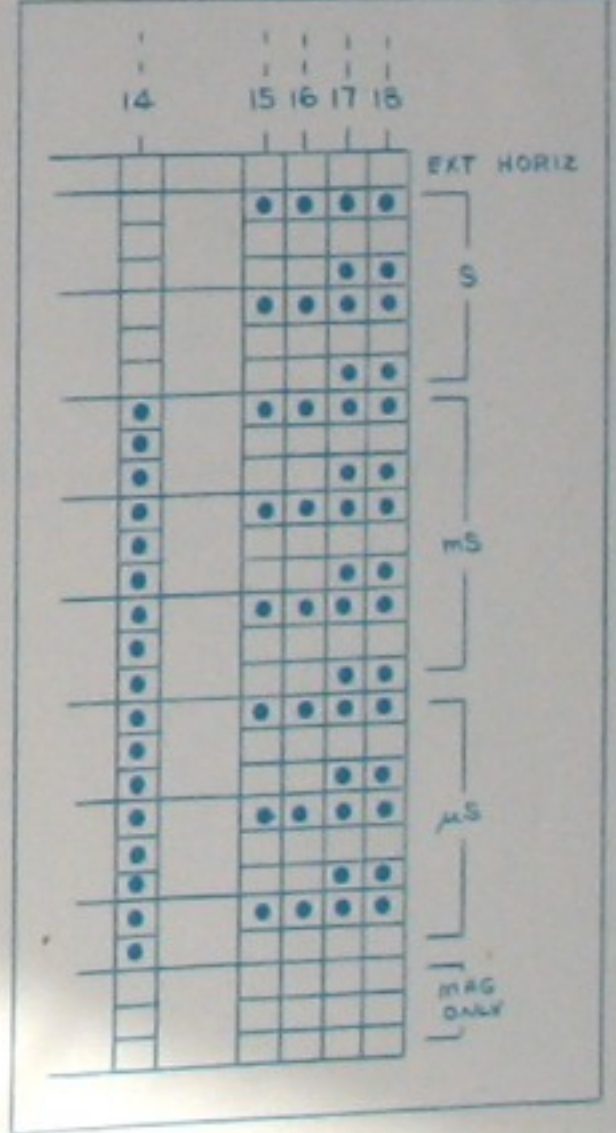

TIME/DIV SWITCH 8

Fig. 8-18 & 8-19

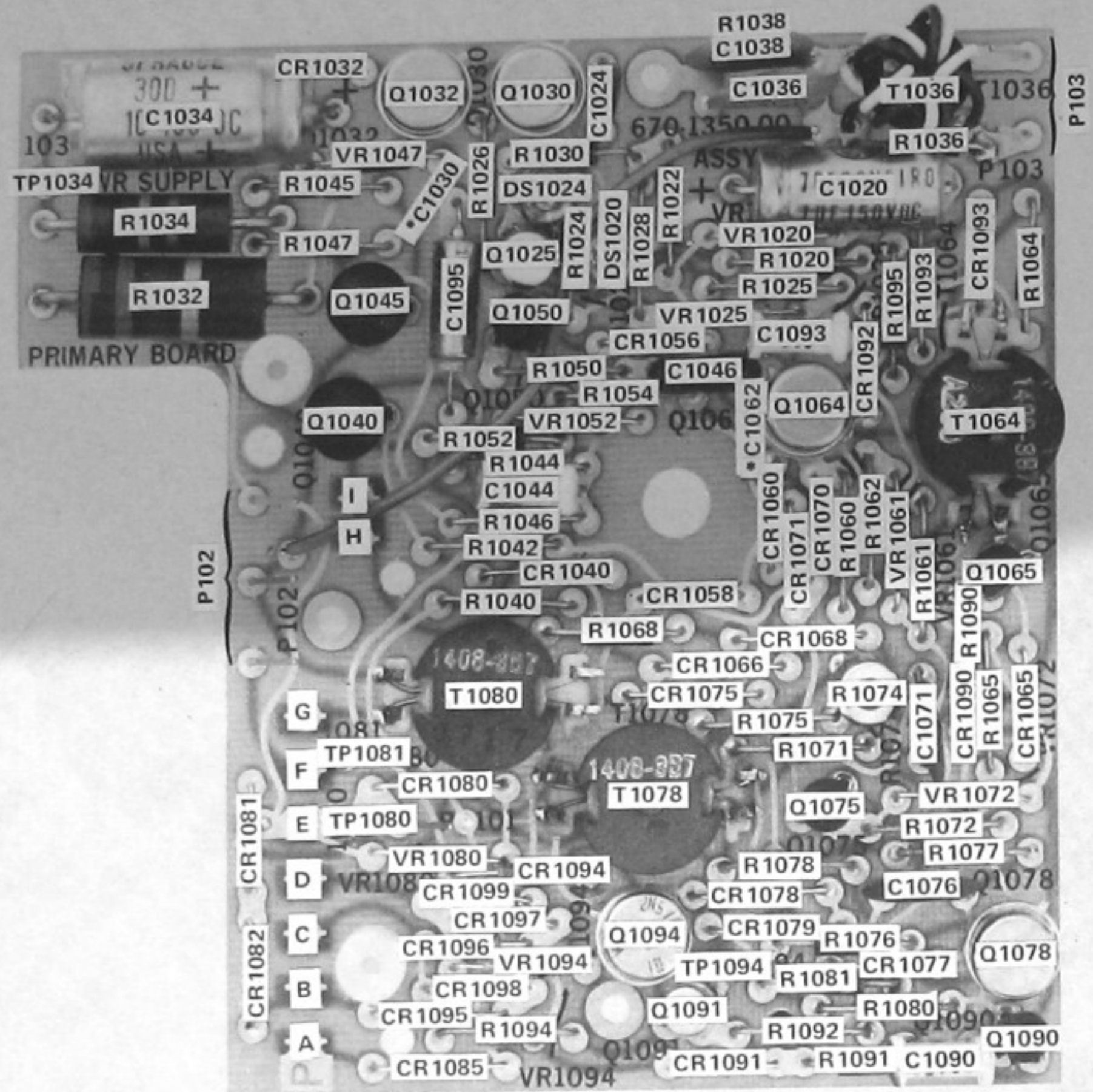

*See Parts List for serial number ranges.

Fig. 8-17. A9. Power Supply Primary circuit board.

REV. APR 1974

Ⓢ

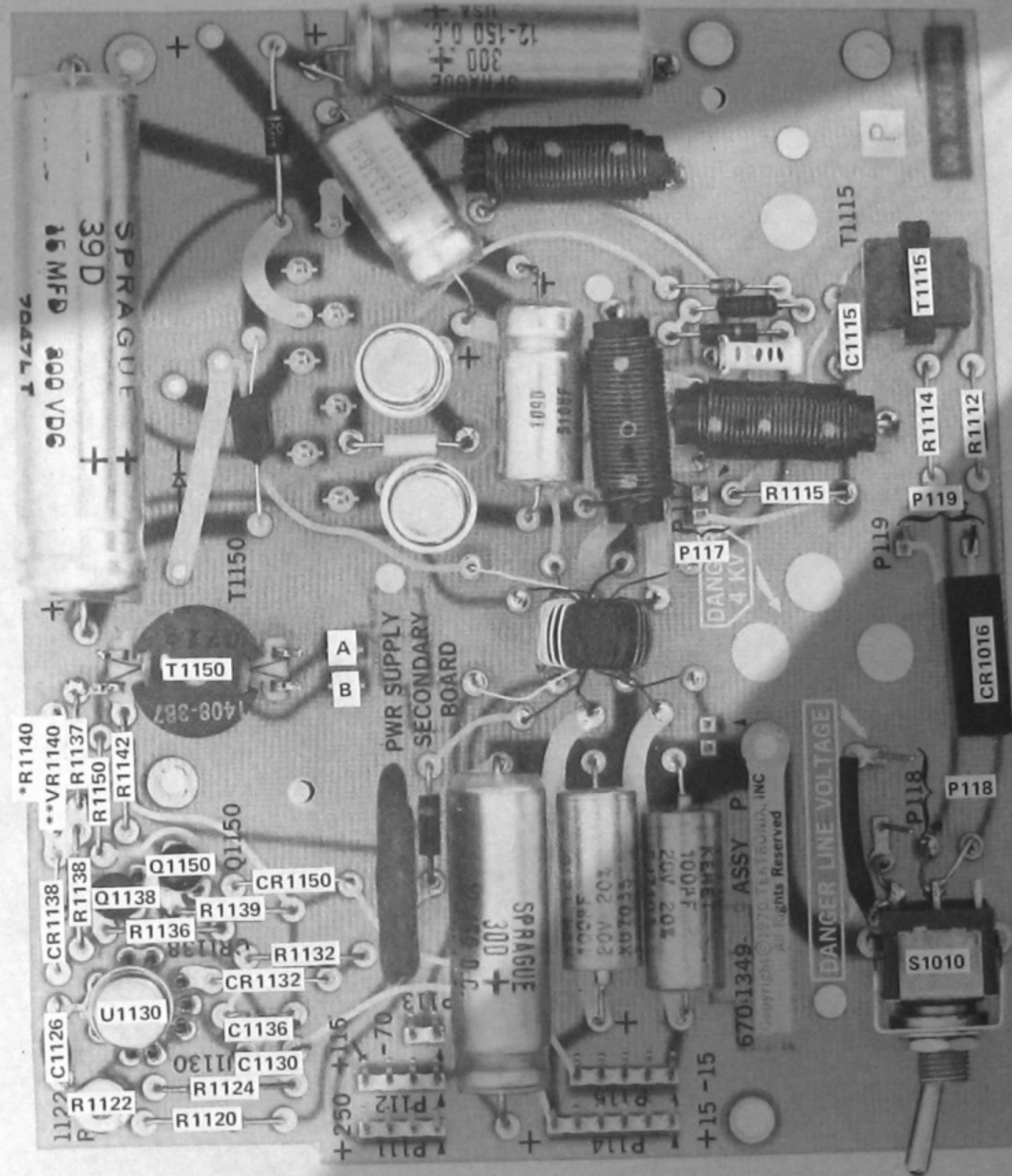

See Fig. 8-20 for location of components not identified here.

*sn B120000 & UP
**BELOW sn B120000

Fig. 8-18. P/O A10. Partial Power Supply Secondary circuit board.

Ⓢ

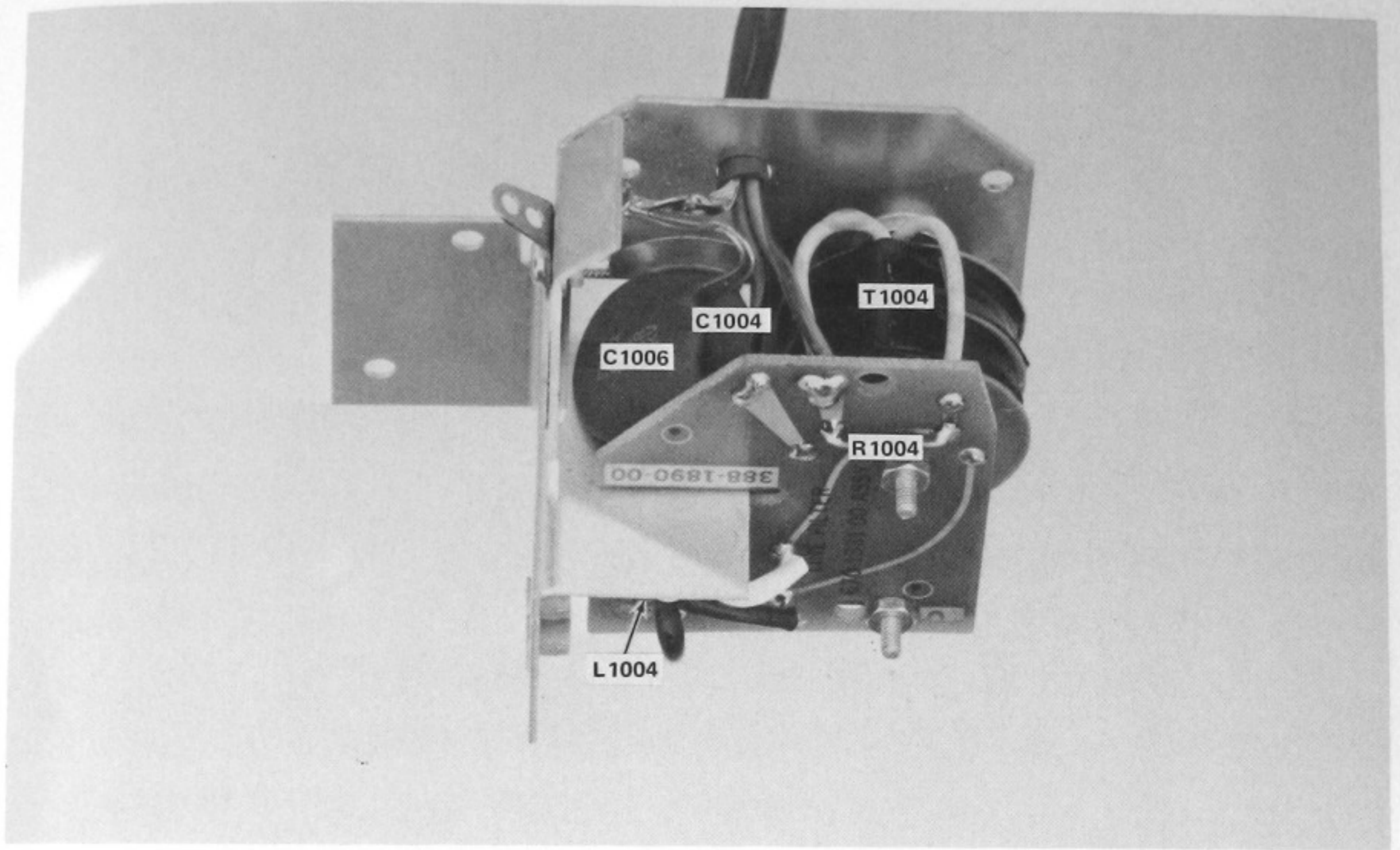
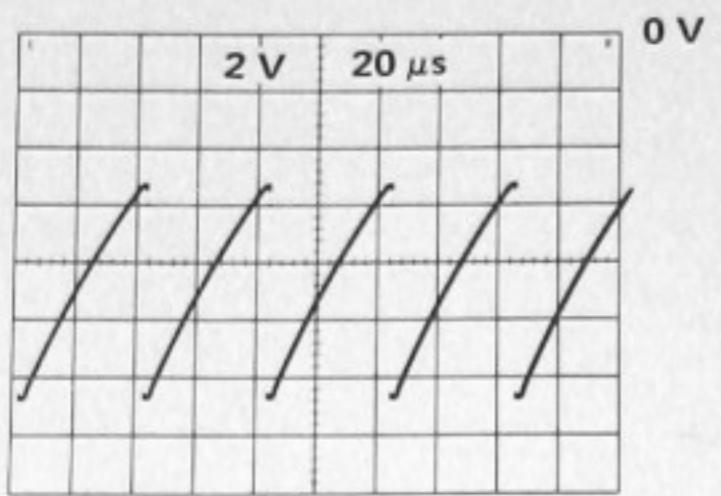

Fig. 8-19. A13. Line filter circuit board.

Ⓐ

1



2

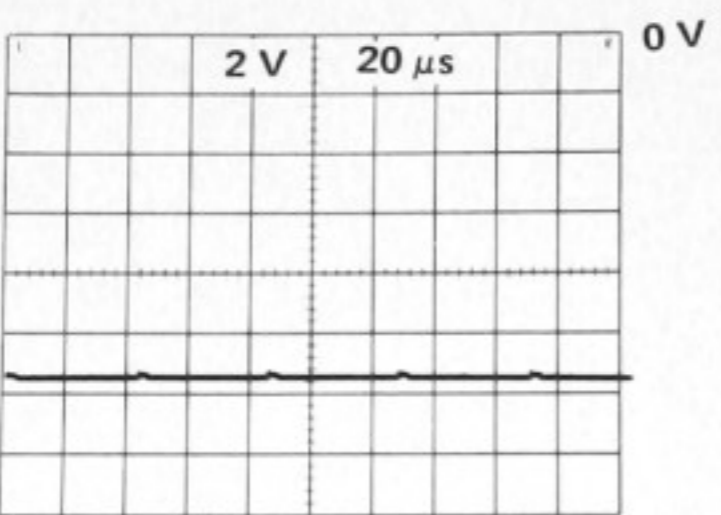

3



4

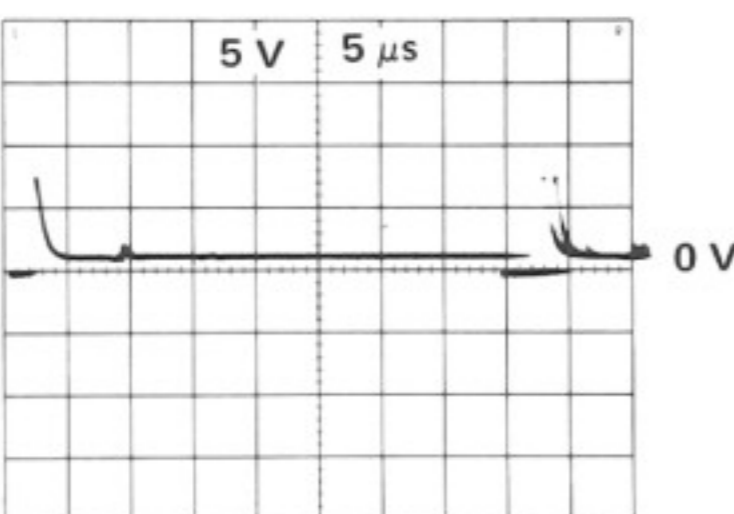

5

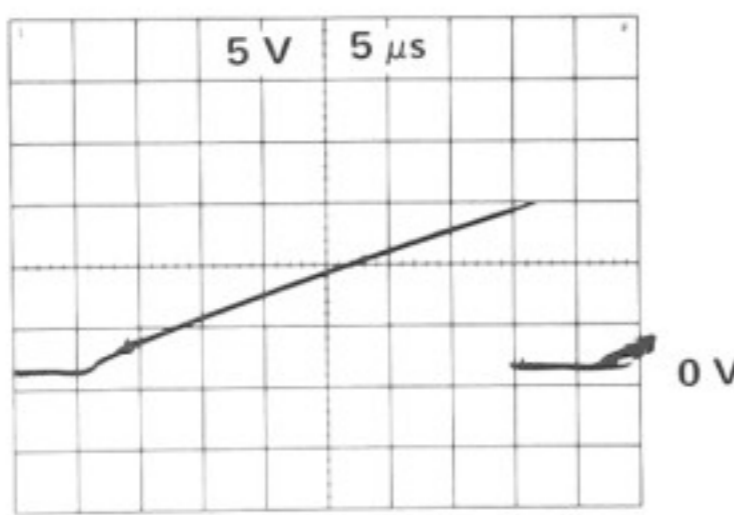

6

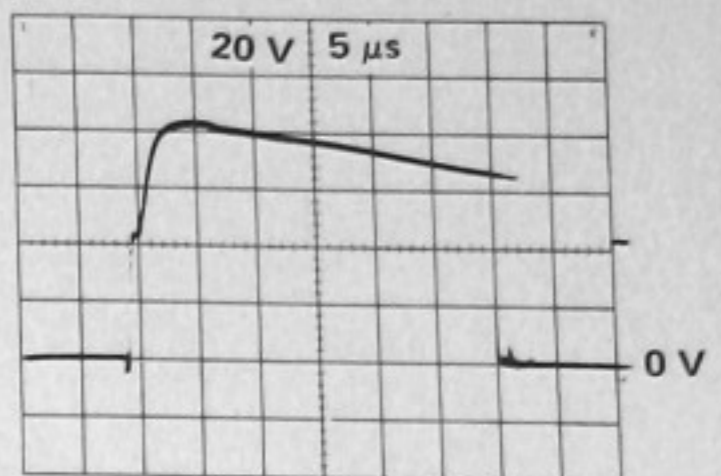

7

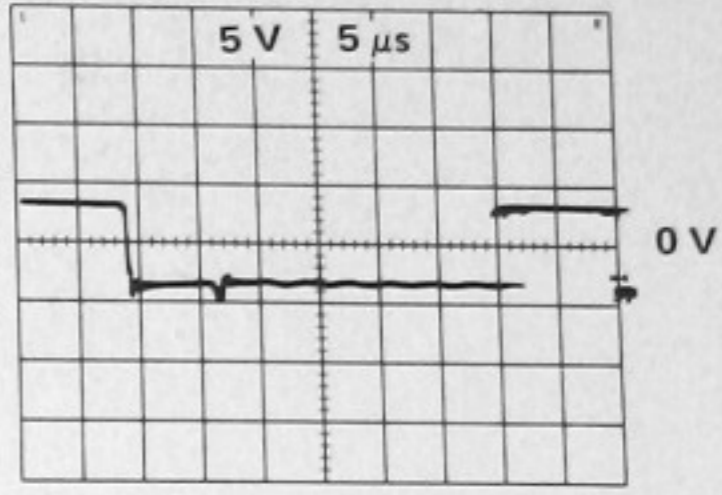

8

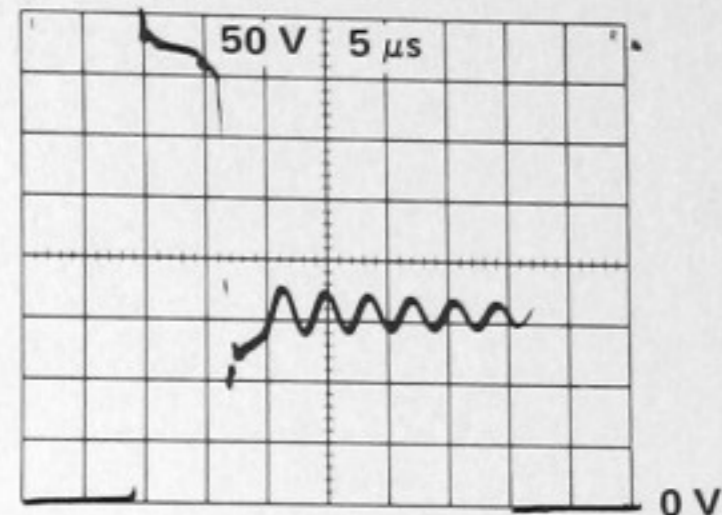

9

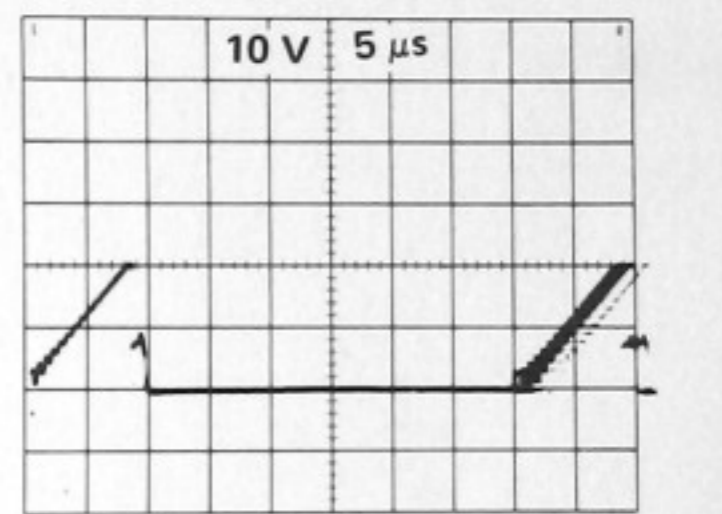

10

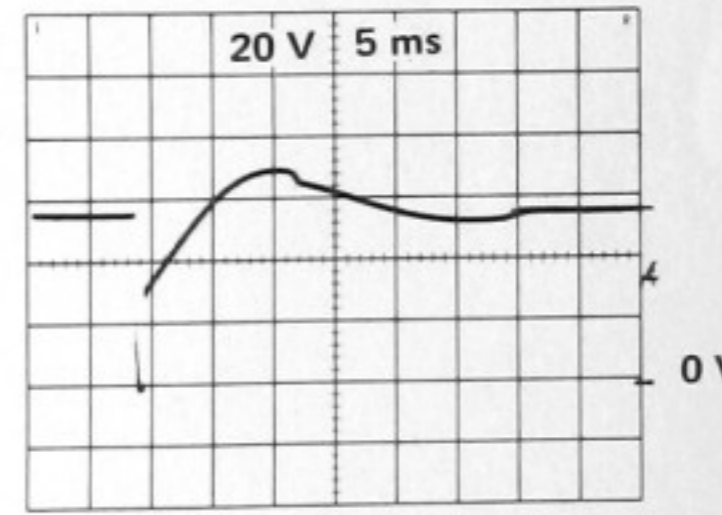

11

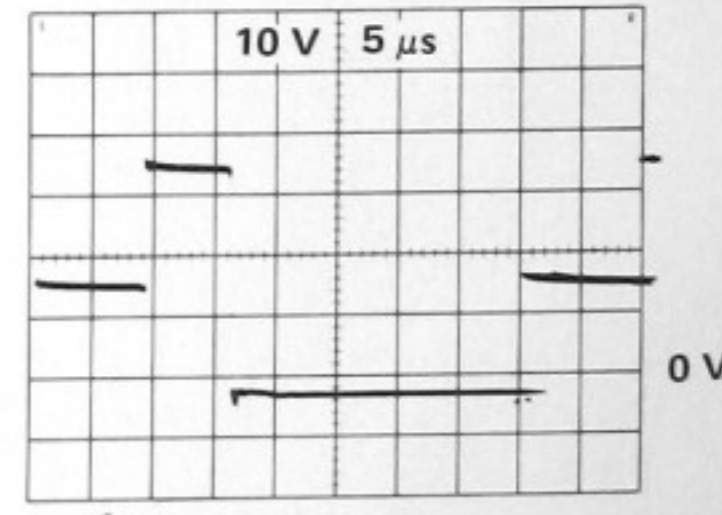

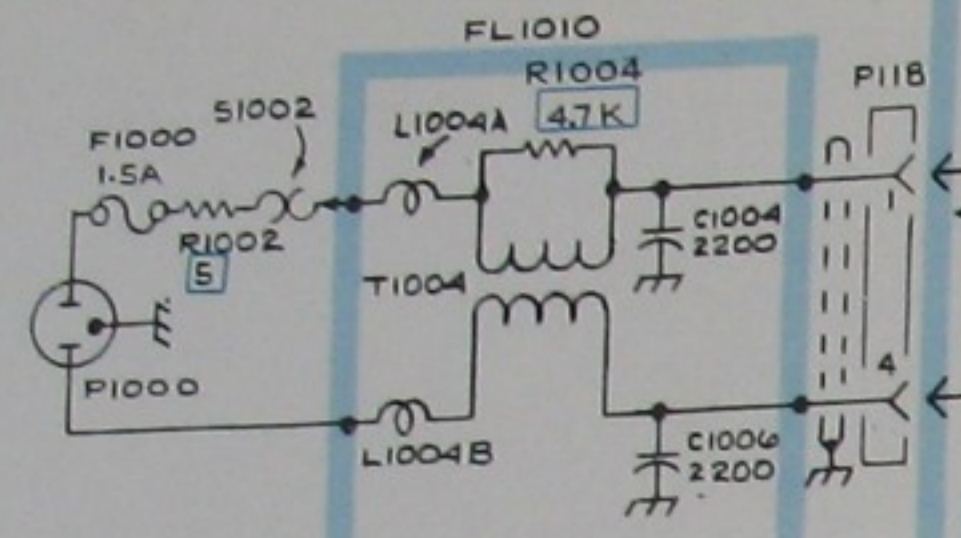

A13 LINE FILTER CKT BOARD

← WAVEFORMS

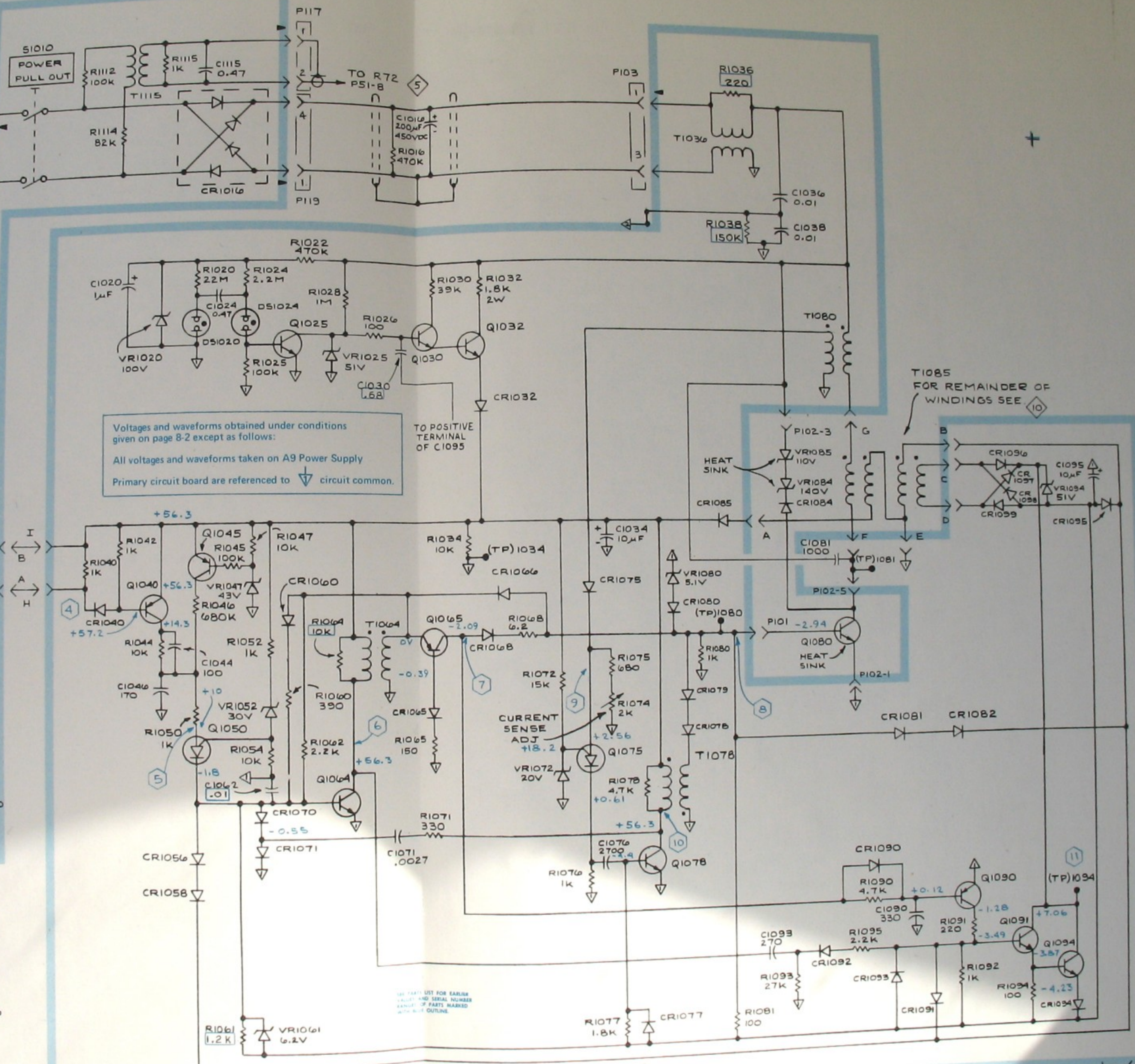

Voltages and waveforms obtained under conditions given on page 8-2 except as follows:
 All voltages and waveforms taken on A9 Power Supply Primary circuit board are referenced to circuit common.

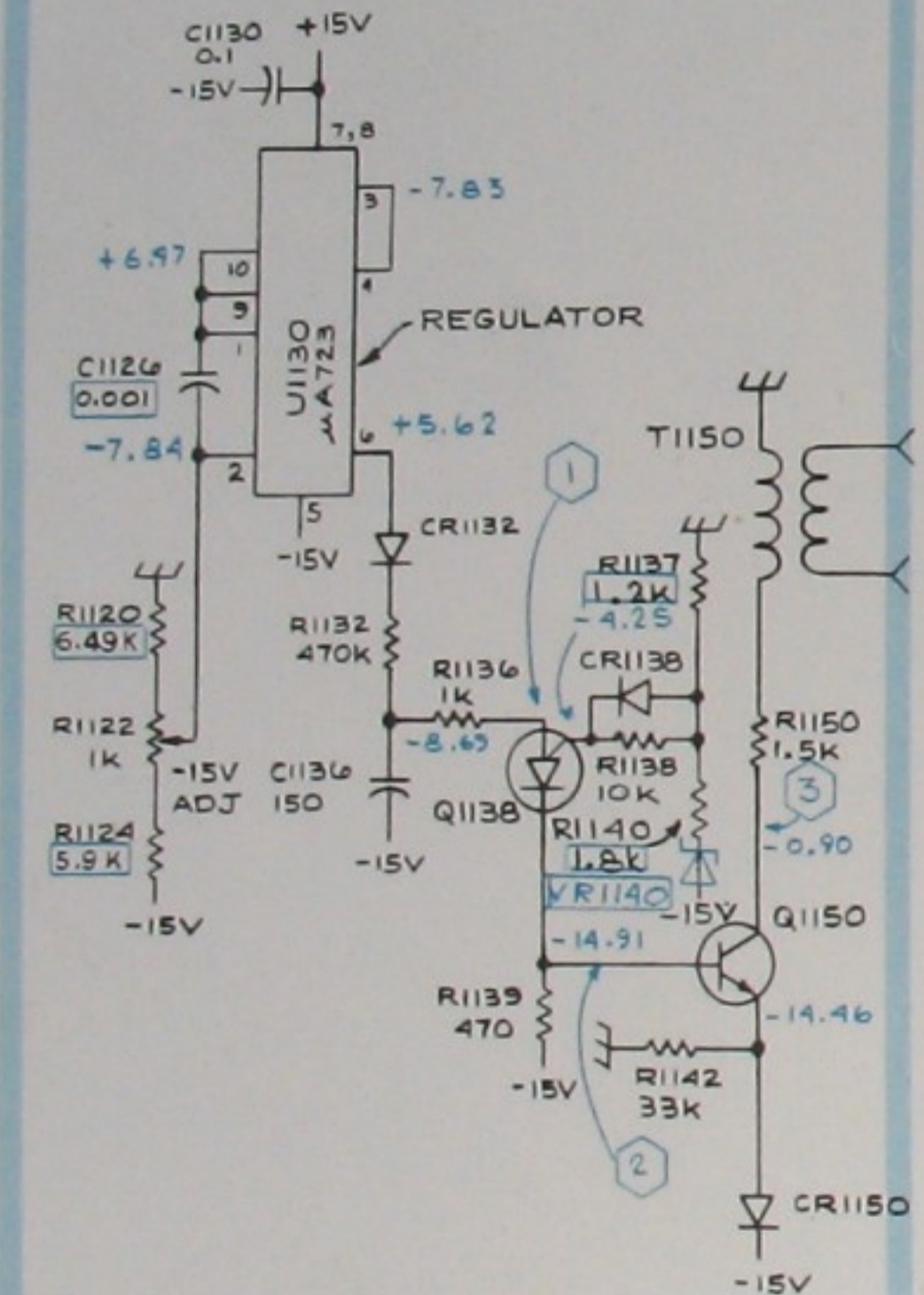

P/O A10 POWER SUPPLY SECONDARY CIRCUIT BOARD

- NOTES:
1. ↓ CIRCUIT COMMON
 2. ↓ GUARD BOX COMMON
 3. SEE PARTS LIST FOR SEMICONDUCTOR TYPES

A9 POWER SUPPLY PRIMARY CIRCUIT BOARD

POWER SUPPLY PRIMARY CIRCUIT & REGULATOR

hq/EEB
REV APR 1974

Fig. 8-21 →

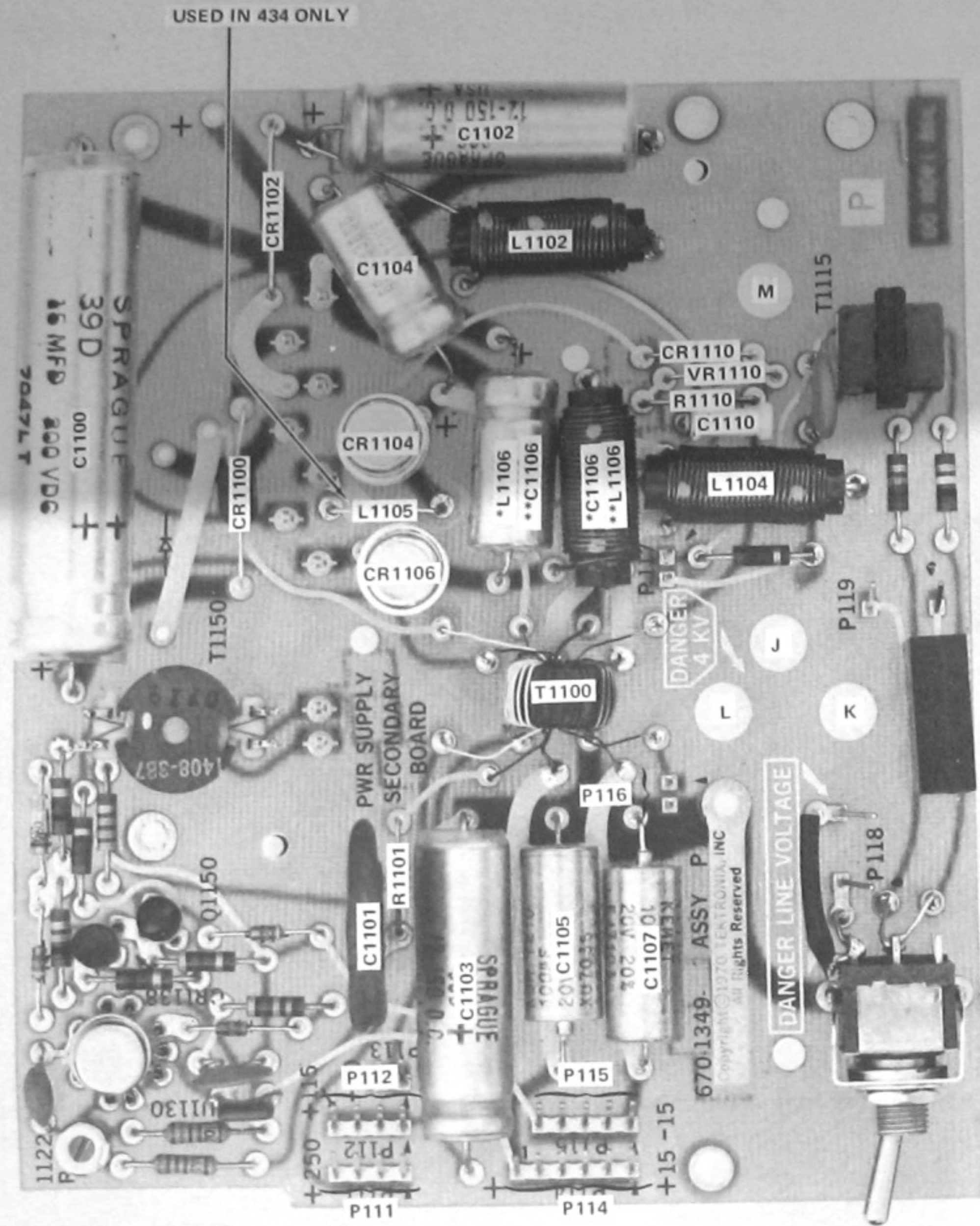

See Fig. 8-18 for location of components not identified here.

*sn B12000 & UP
**BELOW sn B12000

Fig. 8-20. P/O A10. Partial Power Supply Secondary circuit board.

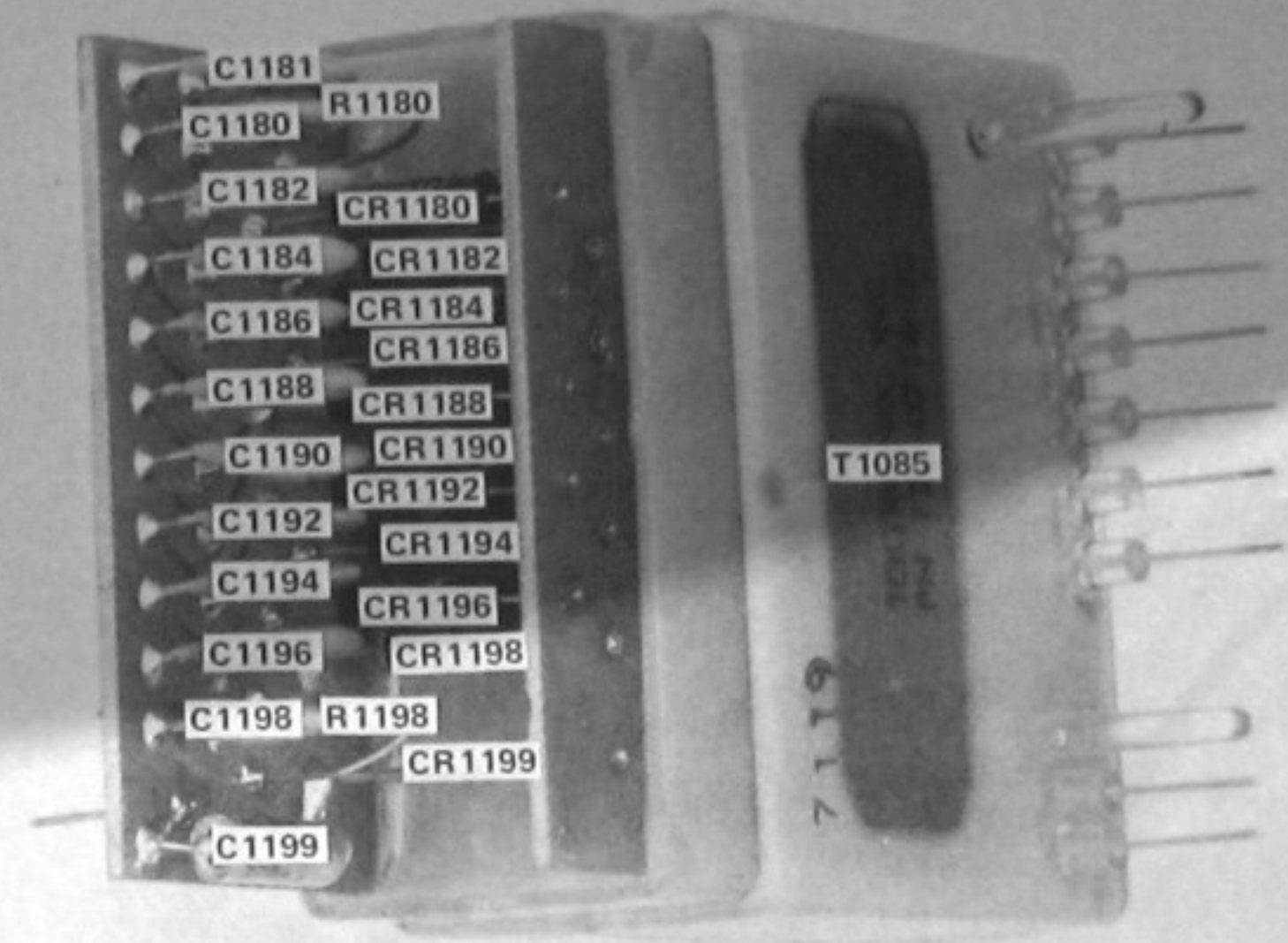
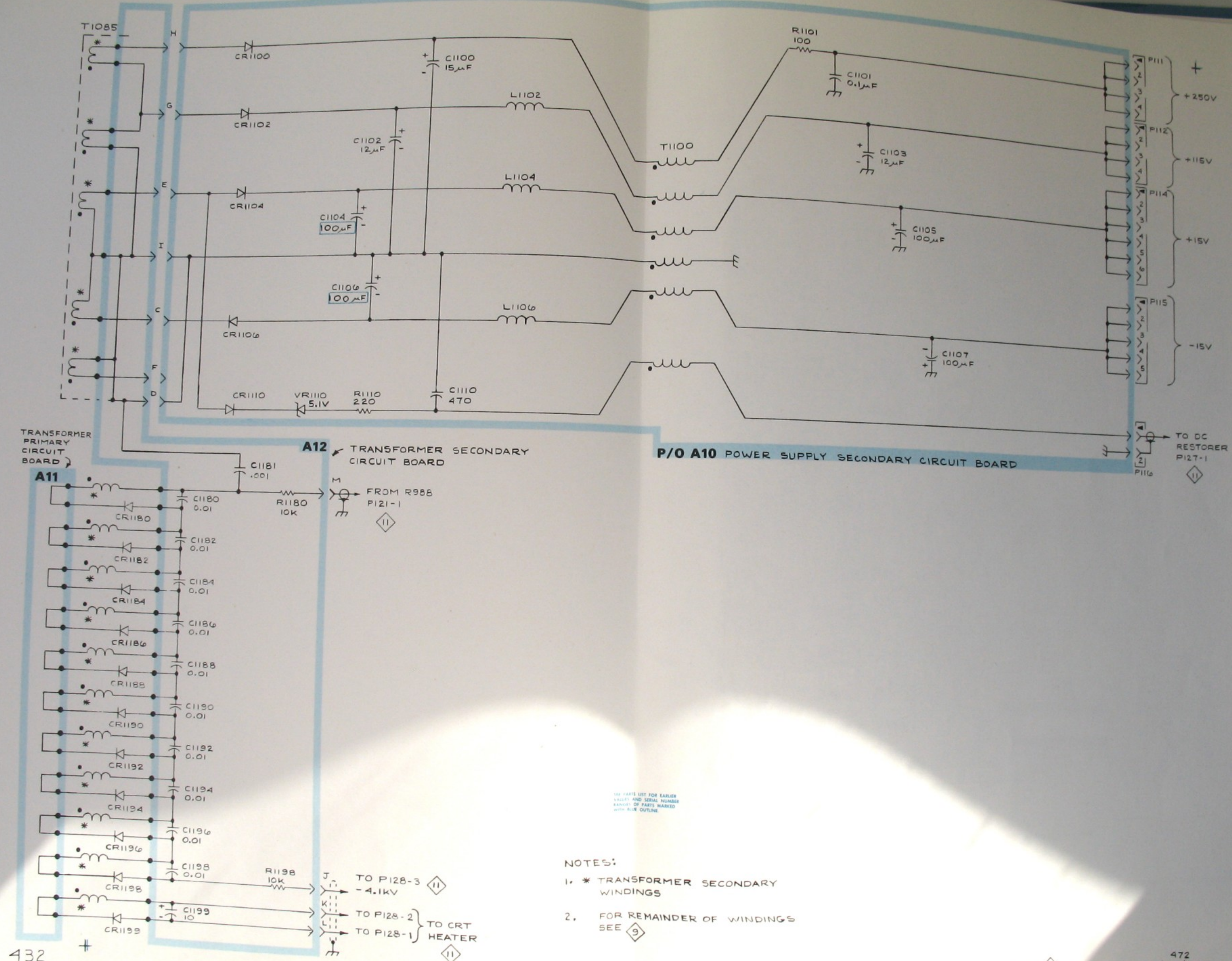

Fig. 8-21. A11 & A12. Transformer Primary and Secondary circuit boards.



SEE PARTS LIST FOR EARLIER VALUES AND SERIAL NUMBER RANGES OF PARTS MARKED WITH BLUE OUTLINE.

NOTES:

1. * TRANSFORMER SECONDARY WINDINGS
2. FOR REMAINDER OF WINDINGS SEE 9

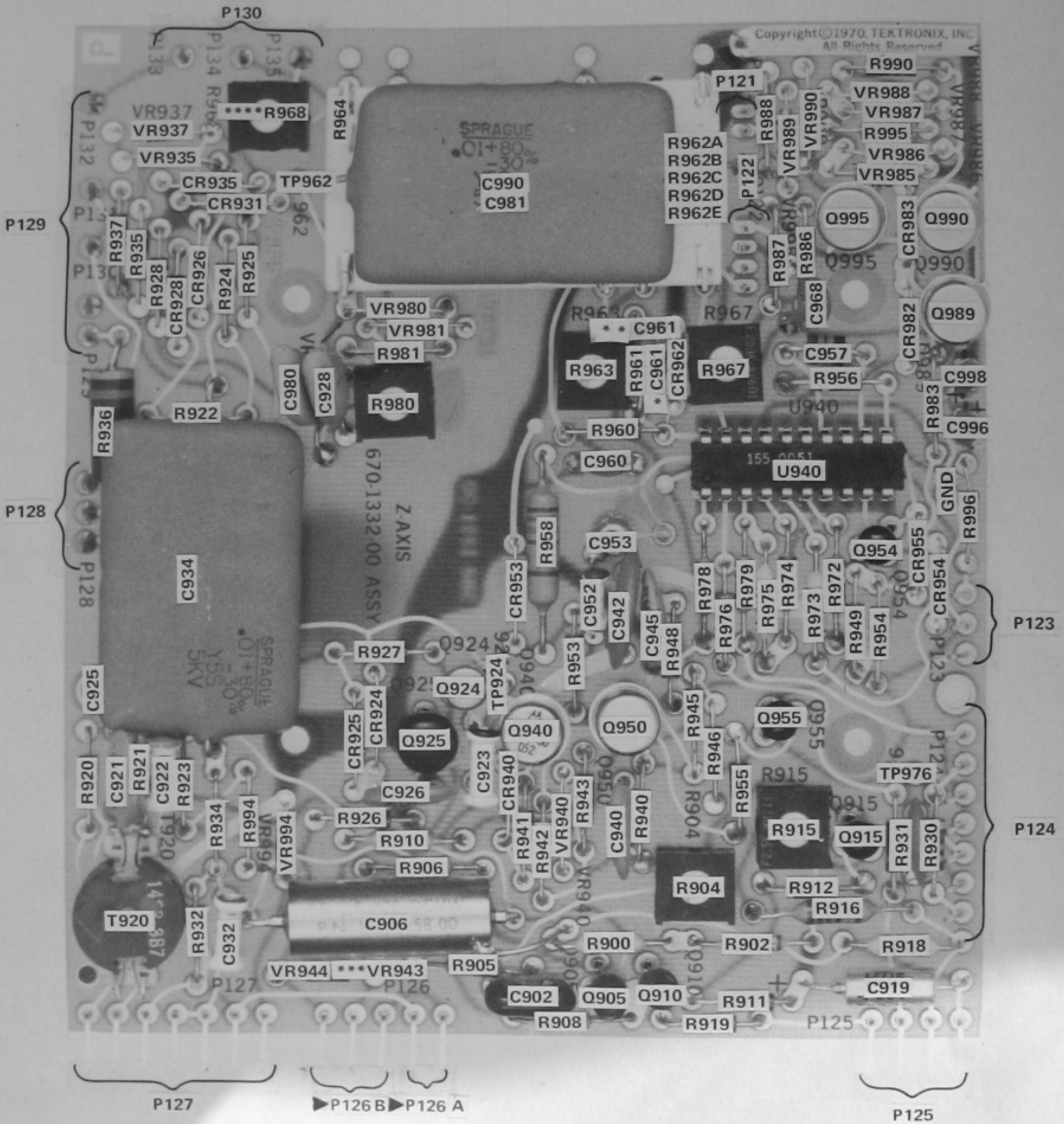

C924 on rear of board

- *Location before sn B110000
- **Location sn B110000 and above
- ***Added SN B180000
- ****Removed SN B190000

Fig. 8-22. A14. Z-Axis circuit board.

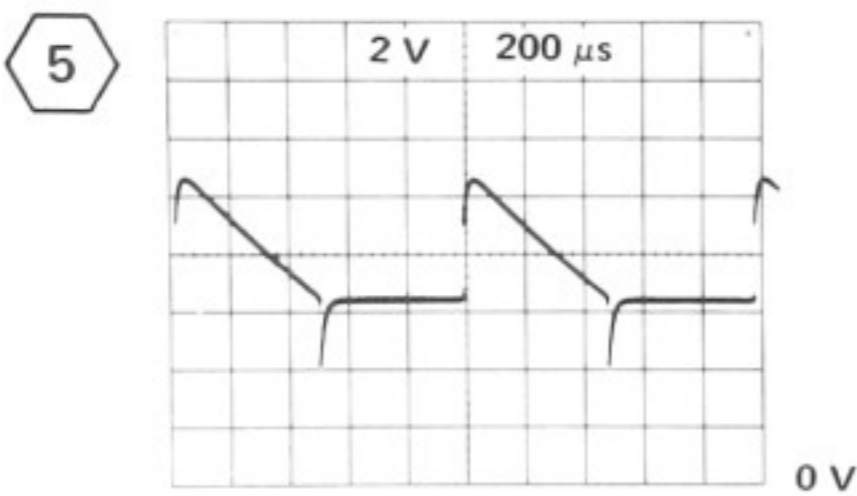
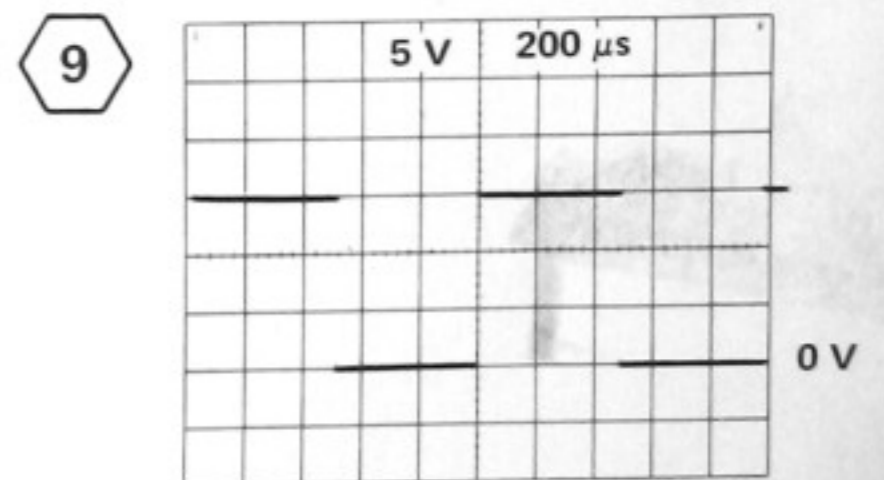
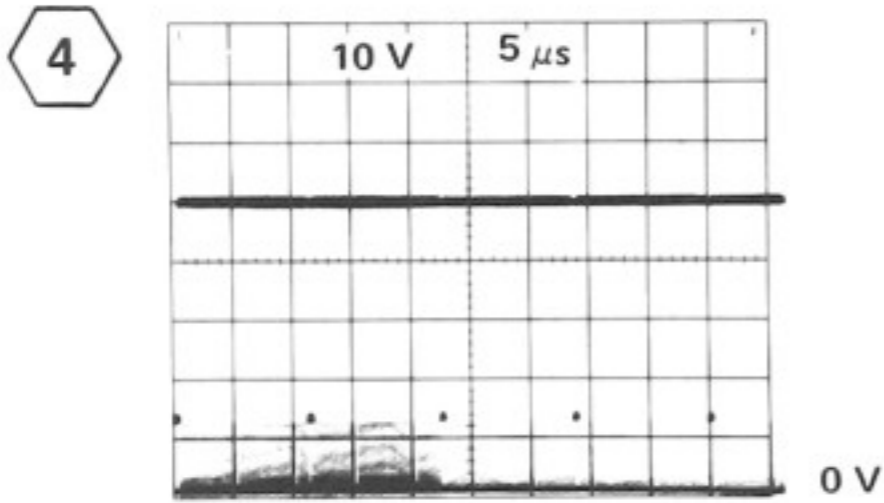
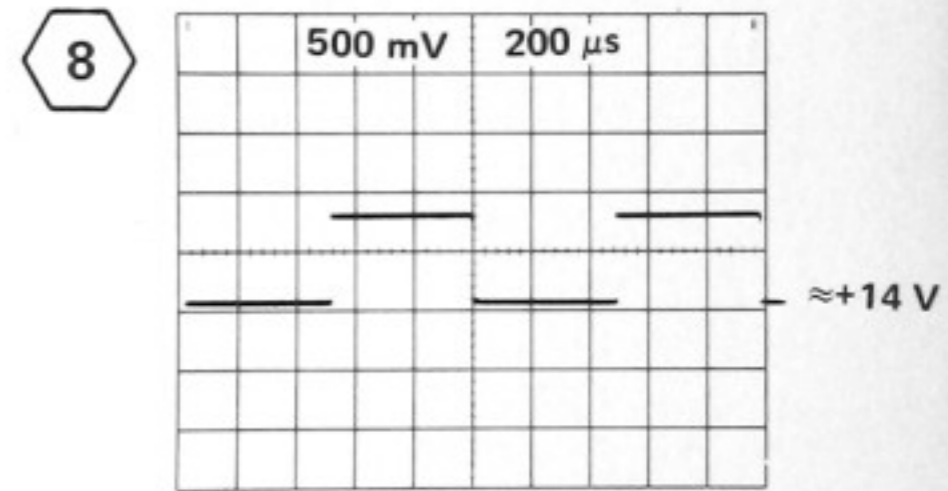
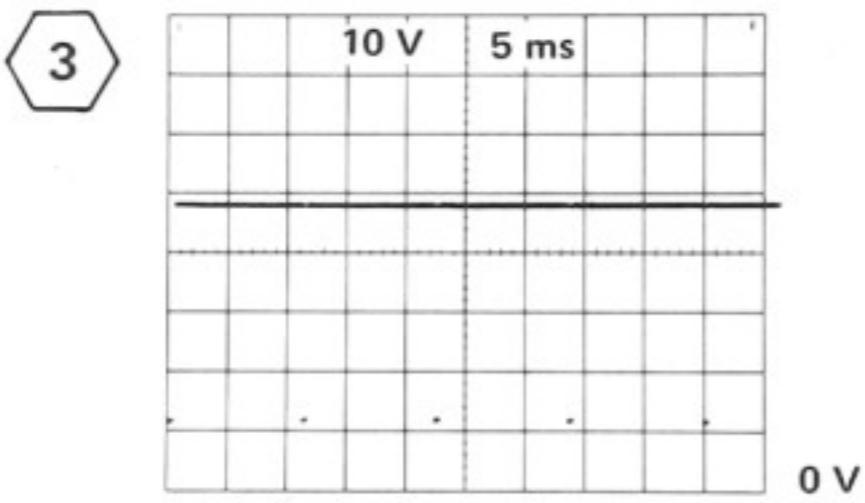
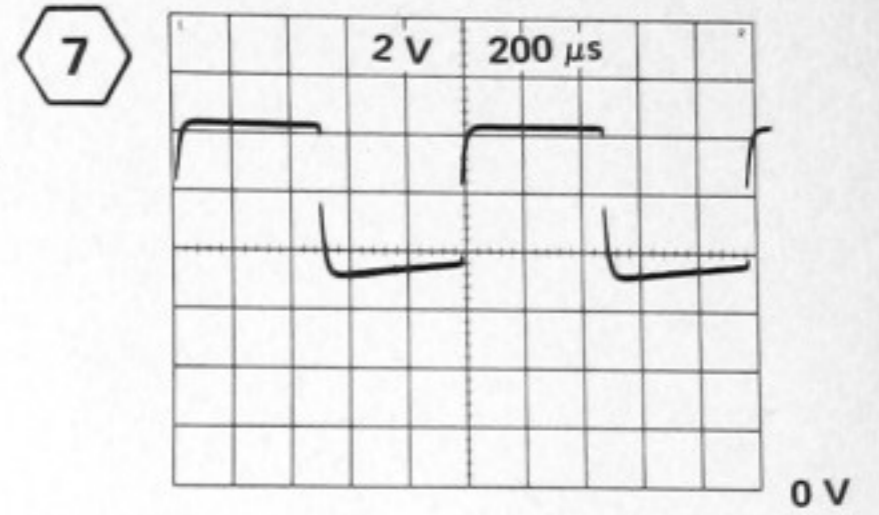
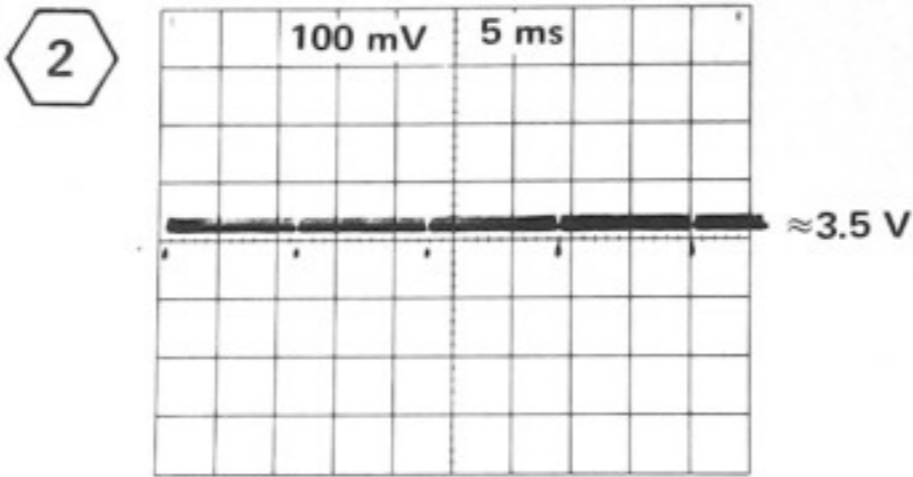
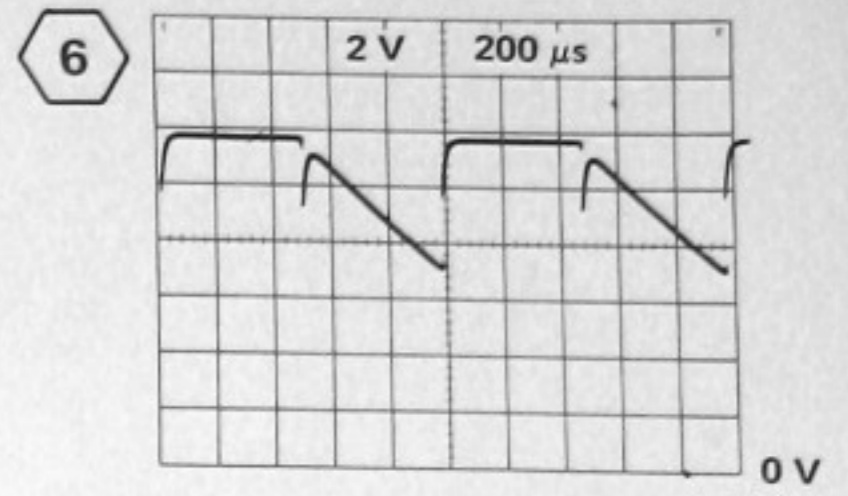
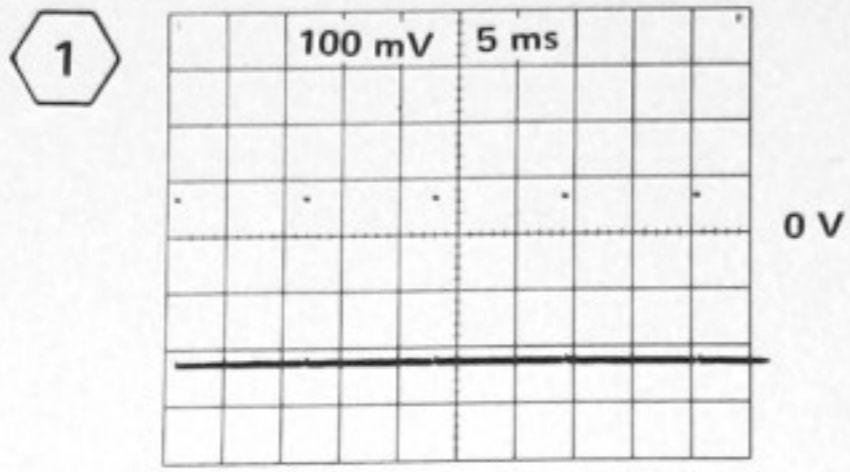

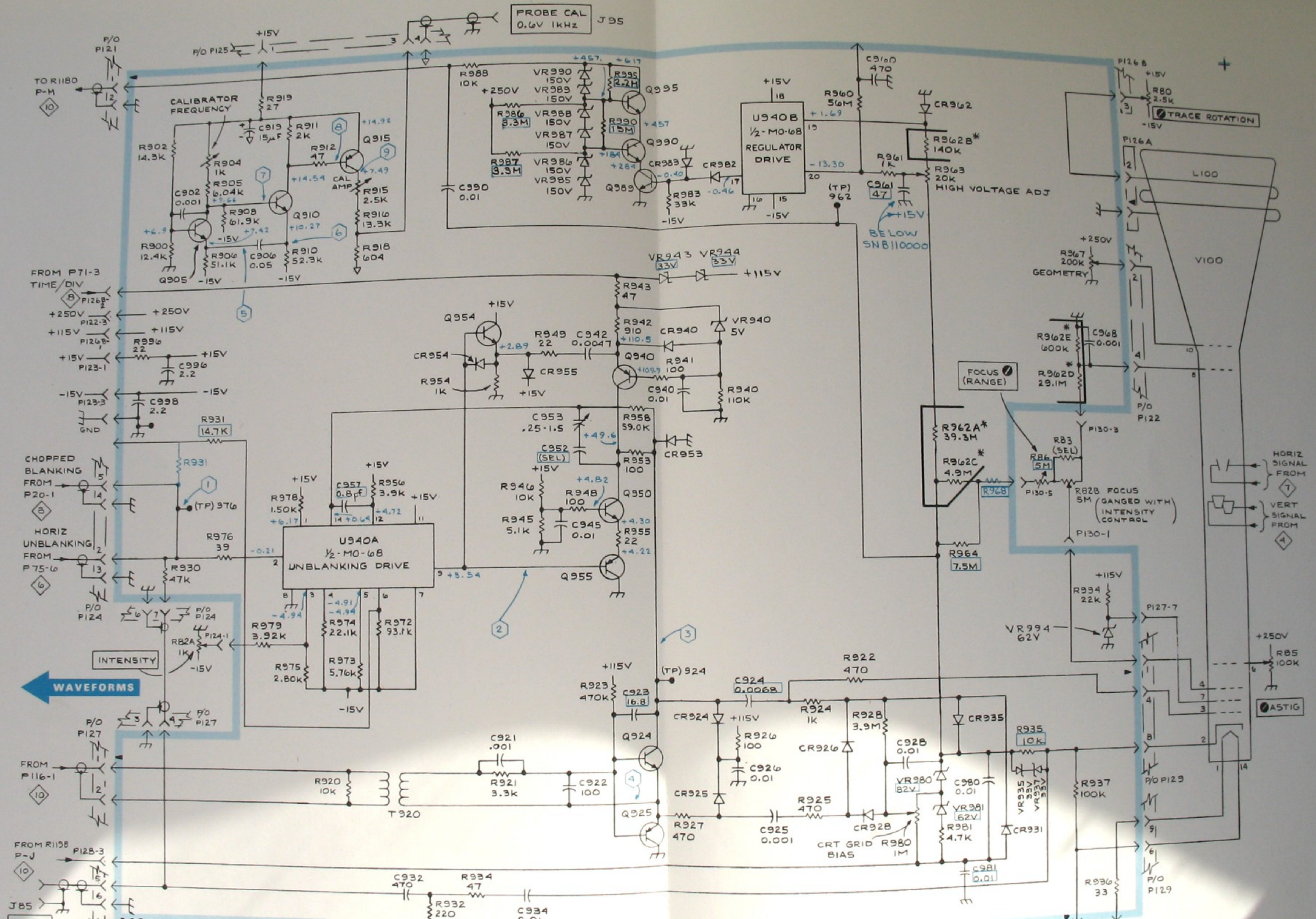

A14 Z AXIS CIRCUIT BOARD

- NOTES:
 1. *THICK FILM RESISTOR
 2. SEE PARTS LIST FOR SEMICONDUCTOR TYPES

Voltagas and waveforms obtained under conditions given on page 8-2.

SEE PARTS LIST FOR EARLIER VALUES AND SERIAL NUMBERS RANGES OF PARTS MARKED WITH BLUE OUTLINE

SECTION 9

MECHANICAL PARTS LIST

FIGURE 1 FRONT

Fig. & Index No.	Tektronix Part No.	Serial/Model Eff	No. Disc	Q					Description	
				t	y	1	2	3		4
1-1	426-0721-00			1						1 FRAME, light filter, plastic
-2	378-0678-00			1						1 FILTER, light, CRT
-3	366-0493-01			2						2 KNOB, red—VARIABLE (CH1 & CH2)
	- - - - -			-						each knob includes:
	213-0153-00			1						1 SETSCREW, 5-40 x 0.125 inch, HSS
-4	366-1281-00			2						2 KNOB, gray—VOLTS/DIV (CH1 & CH2)
	- - - - -			-						each knob includes:
	213-0153-00			2						2 SETSCREW, 5-40 x 0.125 inch, HSS
-5	366-1031-02			1						1 KNOB, red—VARIABLE
	- - - - -			-						knob includes:
	213-0153-00			1						1 SETSCREW, 5-40 x 0.125 inch, HSS
-6	366-1279-00			1						1 KNOB, gray—TIME/DIV
	- - - - -			-						knob includes:
	213-0153-00			2						2 SETSCREW, 5-40 x 0.125 inch, HSS
-7	366-1282-00			1						1 KNOB, push-on—BANDWIDTH
-8	366-1282-00			1						1 KNOB, push-on—INVERT
-9	366-1283-00			2						2 KNOB, gray—POSITION (CH1 & CH2)
	- - - - -			-						each knob includes:
	213-0153-00			1						1 SETSCREW, 5-40 x 0.125 inch, HSS
-10	366-1038-00			1						1 KNOB, gray—POWER & INTENSITY
	- - - - -			-						knob includes:
	213-0153-00			1						1 SETSCREW, 5-40 x 0.125 inch, HSS
-11	366-0494-00			1						1 KNOB, gray—POSITION
	- - - - -			-						knob includes:
	213-0153-00			1						1 SETSCREW, 5-40 x 0.125 inch, HSS
-12	366-1278-00			1						1 KNOB, light gray—SLOPE
	- - - - -			-						knob includes:
	213-0153-00			1						1 SETSCREW, 5-40 x 0.125 inch, HSS
-13	366-1280-00			1						1 KNOB, gray—LEVEL
	- - - - -			-						knob includes:
	213-0153-00			1						1 SETSCREW, 5-40 x 0.125 inch, HSS
-14	366-1257-07			1						1 PUSHBUTTON—AUTO
	366-1257-05			1						1 PUSHBUTTON—NORM
-15	366-1257-08			1						1 PUSHBUTTON—EXT ATTEN
	366-1257-06			1						1 PUSHBUTTON—COMP
	366-1257-01			1						1 PUSHBUTTON—CH 1
-16	366-1257-02			3						3 PUSHBUTTON—AC
	366-1257-10			1						1 PUSHBUTTON—HF REJ
	366-1257-09			1						1 PUSHBUTTON—LF REJ

FIGURE 1 FRONT (cont)

Fig. & Index No.	Tektronix Part No.	Serial/Model Eff	No. Disc	Q † y						Description
					1	2	3	4	5	
1-17	366-1257-03			2						PUSHBUTTON—GND
-18	366-1161-29			1						PUSHBUTTON—CH 1
	366-1161-31			1						PUSHBUTTON—ALT
	366-1161-27			1						PUSHBUTTON—ADD
	366-1161-30			1						PUSHBUTTON—CHOP
	366-1161-28			1						PUSHBUTTON—CH 2
-19	426-0681-00			12						FRAME, pushbutton, small
-20	426-0568-00			5						FRAME, pushbutton, large
-21	358-0378-00			2						BUSHING, sleeve, front panel trim, 0.187 inch
-22	358-0301-02			2						BUSHING, sleeve, front panel trim, 0.185 inch
-23	333-1397-00	B010100	B189999	1						PANEL, front
	333-1397-03	B190000		1						PANEL, front
	- - - - -			-						mounting hardware: (not included w/panel)
-24	211-0079-00			6						SCREW, 2-56 x 0.188 inch, PHS
-25	260-0735-00			2						SWITCH, push—BEAM FINDER & RESET, w/hardware
-26	358-0403-00			1						BUSHING, shaft, plastic
-27	200-0609-00			1						BASE, lampholder
-28	378-0541-00			1						FILTER, lens
-29	352-0084-00			1						HOLDER, neon, plastic, 0.65 inch long
-30	200-0935-00			4						CAP, lampholder
-31	331-0262-00			4						DIFFUSOR, light
-32	352-0157-00			4						LAMPHOLDER, plastic, 0.355 inch long
-33	378-0680-00			4						LENS, knob skirt
-34	348-0276-00			ft						SHIELDING GASKET, 2.80 feet long
-35	131-0679-00			2						CONNECTOR, receptacle, 3 contact, BNC, w/hardware
-36	- - - - -			4						RESISTOR, variable
	- - - - -			-						mounting hardware for each: (not included w/resistor)
-37	210-0538-00			1						NUT, hex., 0.25-32 x 0.312 inch
-38	- - - - -			2						RESISTOR, variable
	- - - - -			-						mounting hardware for each: (not included w/resistor)
-39	358-0409-00			1						BUSHING, 0.25-32 x 0.159 ID
-40	210-0223-00			1						LUG, solder, 0.25 inch diameter, SE
-41	210-0471-00			1						POST, hex., 0.25-32 x 0.312 x 0.594 inch long
-42	210-0046-00			1						WASHER, lock, internal, 0.261 ID x 0.40 inch OD
-43	136-0098-01			1						JACK, tip, 0.25-32 x 0.562 inch long, w/hardware
	- - - - -			-						mounting hardware: (not included w/jack)
-44	210-0223-00			1						LUG, solder, 0.25 inch diameter, SE
-45	260-1229-00	B010100	B219999	1						SWITCH, push—MODE
	260-1229-01	B220000		1						SWITCH, push—MODE
	- - - - -			-						mounting hardware: (not included w/switch)
-46	211-0034-00			2						SCREW, 2-56 x 0.50 inch, PHS
-47	166-0251-00			2						TUBE, spacer, 0.125 x 0.297 inch long

FIGURE 1 FRONT (cont)

Fig. & Index No.	Tektronix Part No.	Serial/Model No. Eff	No. Disc	Q † Y						Description
					1	2	3	4	5	
1-48	670-1363-00			1						CIRCUIT BOARD ASSEMBLY—TRIGGER COUPLING A7
	- - - - -			-						circuit board assembly includes:
	388-1922-00			1						CIRCUIT BOARD
-49	131-0589-00			3						TERMINAL, pin, 0.50 inch long
-50	260-1226-00			1						SWITCH, push, 2 button
-51	260-1224-00			1						SWITCH, push
	- - - - -			-						mounting hardware: (not included w/circuit board assembly)
-52	211-0017-00			2						SCREW, 4-40 x 0.75 inch, RHS
-53	361-0368-00			2						SPACER, pushbutton switch
-54	670-1364-00			1						CIRCUIT BOARD ASSEMBLY—TRIGGER SOURCE A6
	- - - - -			-						circuit board assembly includes:
	388-1923-00			1						CIRCUIT BOARD
-55	131-0589-00			10						TERMINAL, pin, 0.50 inch long
-56	260-1228-00	B010100	B219999	1						SWITCH, push, 2 button
	260-1228-01	B220000		1						SWITCH, push, 2 button
-57	260-1224-00			1						SWITCH, push
-58	342-0096-00			1						INSULATOR, plate, push switch
-59	337-1455-00			1						SHIELD-CONTACT ASSEMBLY
	- - - - -			-						shield-contact assembly includes:
	342-0094-00			1						INSULATOR, plate, plastic
-60	131-1086-00			2						CONTACT, ground
	- - - - -			-						mounting hardware for each: (not included w/contact)
-61	211-0007-00			2						SCREW, 4-40 x 0.188 inch, PHS
-62	670-1358-00			1						CIRCUIT BOARD ASSEMBLY—VERTICAL MODE A3
	- - - - -			-						circuit board assembly includes:
	388-1917-00			1						CIRCUIT BOARD
-63	131-0589-00			6						TERMINAL, pin, 0.50 inch long
-64	260-1227-00			2						SWITCH, push—AC GND
-65	260-1230-00			1						SWITCH, push—VERTICAL MODE
-66	337-1434-00			2						SHIELD, electrical
	- - - - -			-						mounting hardware for each: (not included w/shield)
-67	210-0406-00			2						NUT, hex., 4-40 x 0.188 inch
-68	210-0288-00			2						TERMINAL, lug, 0.125 ID x 1.125 inches long
	210-0994-00			4						WASHER, flat, 0.125 ID x 0.25 inch OD
	- - - - -			-						mounting hardware: (not included w/circuit board assembly)
-69	211-0116-00			2						SCREW, sems, 4-40 x 0.312 inch, PHB
-70	358-0363-00			3						BUSHING, for 0.25 inch shaft
	- - - - -			-						mounting hardware for each: (not included w/bushing)
-71	220-0495-00			1						NUT, hex., 0.375-32 x 0.438 inch
-72	210-0840-00			1						WASHER, flat, 0.39 ID x 0.562 inch OD
-73	386-1854-01			1						SUBPANEL, front
-74	670-1359-02	B010100	B019999	1						CIRCUIT BOARD ASSEMBLY—HORIZONTAL A8
	670-1359-04	B020000	B049999	1						CIRCUIT BOARD ASSEMBLY—HORIZONTAL A8
	670-1359-08	B050000	B059999	1						CIRCUIT BOARD ASSEMBLY—HORIZONTAL A8
	670-1359-10	B060000		1						CIRCUIT BOARD ASSEMBLY—HORIZONTAL A8
	- - - - -			-						circuit board assembly includes:
	388-1918-00	B010100	B049999	1						CIRCUIT BOARD
	388-1918-01	B050000		1						CIRCUIT BOARD
-75	131-0589-00			37						TERMINAL, pin, 0.50 inch long

FIGURE 1 FRONT (cont)

Fig. & Index No.	Tektronix Part No.	Serial/Model Eff	No. Disc	Q † Y	1 2 3 4 5					Description
					1	2	3	4	5	
-76	131-0604-00	B010100	B049999	24						CONTACT, electrical, cam switch
	131-0604-00	B050000		25						CONTACT, electrical, cam switch
-77	136-0235-00			5						SOCKET, transistor, 6 pin
-78	136-0241-00			1						SOCKET, integrated circuit, 10 pin
-79	136-0252-04			87						SOCKET, pin connector
-80	214-0579-00			18						PIN, test point
	105-0262-00	B010100	B049999	1						ACTUATOR ASSEMBLY, cam switch
	105-0262-01	B050000		1						ACTUATOR ASSEMBLY, cam switch
	- - - - -			-						actuator assembly includes:
-81	200-1208-00			1						COVER, cam switch
	- - - - -			-						mounting hardware: (not included w/cover)
-82	211-0079-00			6						SCREW, 2-56 x 0.188 inch, RHS
-83	210-0001-00			6						WASHER, lock, internal, 0.092 ID x 0.18 inch OD
-84	210-0405-00			6						NUT, hex., 2-56 x 0.188 inch
-85	344-0140-00	B010100	B039999X	1						CLIP, spring tension, plastic
	- - - - -			-						mounting hardware: (not included w/clip)
-86	211-0079-00			1						SCREW, 2-56 x 0.188 inch, RHS
-87	210-0001-00			1						WASHER, lock, internal, 0.092 ID x 0.18 inch OD
-88	210-0405-00			1						NUT, hex., 2-56 x 0.188 inch
-89	105-0232-00			1						STOP, stationary
	- - - - -			-						mounting hardware: (not included w/stop)
-90	211-0079-00			2						SCREW, 2-56 x 0.188 inch, RHS
-91	210-0001-00			2						WASHER, lock, internal, 0.092 ID x 0.18 inch OD
-92	105-0233-00			1						STOP, rotary
-93	401-0056-01			1						BEARING, rear
	- - - - -			-						mounting hardware: (not included w/bearing)
-94	210-0406-00			2						NUT, hex., 4-40 x 0.188 inch
-95	407-0653-00			1						BRACKET, center support
	- - - - -			-						mounting hardware: (not included w/bracket)
	210-0406-00			2						NUT, hex., 4-40 x 0.188 inch
-96	105-0231-00	B010100	B049999	1						DRUM, sweep
	105-0231-01	B050000		1						DRUM, sweep
-97	401-0064-00			2						BEARING, front
	- - - - -			-						mounting hardware for each: (not included w/bearing)
	210-0406-00			2						NUT, hex., 4-40 x 0.188 inch
-98	214-1127-00			2						ROLLER, detent
-99	214-1139-00 ¹			-						SPRING, flat, gold
	214-1139-02 ¹			-						SPRING, flat, green
	214-1139-03 ¹			-						SPRING, flat, red
-100	210-1131-00			1						WASHER, plastic, 0.375 ID x 0.562 inch OD
-101	376-0122-00			1						COUPLING, sweep
	- - - - -			-						coupling includes:
	213-0153-00			1						SETSCREW, 5-40 x 0.125 inch, HSS
-102	384-0799-01			1						SHAFT, 5.948 inches long, w/driver

¹Replace only with part bearing the same color code as the original part in your instrument.

FIGURE 1 FRONT (cont)

Fig. & Index No.	Tektronix Part No.	Serial/Model No. Eff	No. Disc	Q † y	1 2 3 4 5					Description
					1	2	3	4	5	
1-103	214-1541-00			1						SPRING, helical compression
-104	376-0121-00			1						COUPLER, mag
	- - - - -			-						coupler includes:
	213-0153-00			1						SETSCREW, 5-40 x 0.125 inch, HSS
-105	105-0230-00			1						DRUM, mag
-106	401-0056-00			1						BEARING, rear
	- - - - -			-						mounting hardware: (not included w/bearing)
	210-0406-00			2						NUT, hex., 4-40 x 0.188 inch
-107	354-0390-00			1						RING, retaining
-108	- - - - -			1						RESISTOR, variable
	- - - - -			-						resistor includes:
	384-1084-00			1						SHAFT, extension
	- - - - -			-						mounting hardware: (not included w/resistor)
-109	211-0079-00			2						SCREW, 2-56 x 0.188 inch, RHS
-110	210-0001-00			2						WASHER, lock, internal, 0.092 ID x 0.18 inch OD
-111	129-0301-00			2						POST, hex., 2-56 x 0.156 x 0.312 inch long
	- - - - -			-						mounting hardware for each: (not included w/post)
-112	211-0079-00			1						SCREW, 2-56 x 0.188 inch, RHS
-113	210-0001-00			1						WASHER, lock, internal, 0.092 ID x 0.18 inch OD
-114	213-0153-00			1						SETSCREW, 5-40 x 0.312 inch, HSS
	- - - - -			-						mounting hardware: (not included w/actuator assembly)
-115	211-0116-00			10						SCREW, sems, 4-40 x 0.312 inch, PHB
	- - - - -			-						mounting hardware: (not included w/circuit board assembly)
	211-0116-00			3						SCREW, sems, 4-40 x 0.312 inch, PHB (not shown)
	119-0267-01			1						DELAY LINE ASSEMBLY
	- - - - -			-						delay line assembly includes:
-116	200-1181-00			2						COVER HALF, plastic
	- - - - -			-						mounting hardware: (not included w/cover halves)
-117	211-0097-00			3						SCREW, 4-40 x 0.312 inch, PHS
-118	210-0551-00			3						NUT, hex., 4-40 x 0.25 inch
-119	119-0267-00			1						DELAY LINE
-120	352-0198-00			2						HOLDER, terminal connector, 2 wire (black)
-121	352-0200-00			1						HOLDER, terminal connector, 4 wire (black)
-122	131-0621-00			4						CONNECTOR, terminal
	131-0622-00			4						CONNECTOR, terminal
-123	348-0003-00			1						GROMMET, rubber, 0.312 inch diameter
	- - - - -			-						mounting hardware: (not included w/delay line assembly)
-124	211-0097-00			1						SCREW, 4-40 x 0.312 inch, PHS
-125	337-1424-00			1						SHIELD
	- - - - -			-						mounting hardware: (not included w/shield)
-126	211-0189-00			2						SCREW, plastic, 4-40 x 0.875 inch, PH
-127	210-0869-00			2						WASHER, plastic, 0.156 ID x 0.375 inch OD
-128	361-0396-00			2						SPACER, plastic, 0.125 ID x 0.25 OD x 0.55 inch long

FIGURE 1 FRONT (cont)

Fig. & Index No.	Tektronix Part No.	Serial/Model No. Eff	No. Disc	Q t y	1	2	3	4	5	Description
1-129	670-1332-00	B010100	B059999	1						CIRCUIT BOARD ASSEMBLY—Z AXIS A14
	670-1332-02	B060000	B179999	1						CIRCUIT BOARD ASSEMBLY—Z AXIS A14
	670-1332-03	B180000	B189999	1						CIRCUIT BOARD ASSEMBLY—Z AXIS A14
	670-1332-04	B190000		1						CIRCUIT BOARD ASSEMBLY—Z AXIS A14
	- - - - -			-						circuit board assembly includes:
	388-1891-00			1						CIRCUIT BOARD
-130	131-0589-00			37						TERMINAL, pin, 0.50 inch long
	131-0608-00			7						TERMINAL, pin, 0.365 inch long
-131	136-0252-04			56						SOCKET, connector pin
-132	214-0579-00			3						PIN, test point
	386-1635-00	XB200000		1						SUPPORT, circuit board, 0.11 inch
	386-1556-00	XB200000		1						SUPPORT, circuit board, 0.215 inch
	- - - - -			-						mounting hardware: (not included w/circuit board assembly)
-133	211-0116-00			2						SCREW, sems, 4-40 x 0.312 inch, PHB
-134	407-0905-00			2						BRACKET, storage circuit board
-135	407-0875-00			2						BRACKET, Z-axis circuit board
	- - - - -			-						mounting hardware for each: (not included w/bracket)
-136	211-0511-00			1						SCREW, 6-32 x 0.50 inch, PHS
	211-0514-00			1						SCREW, 6-32 x 0.70 inch, PHS
-137	220-0444-00			2						NUT, square, 6-32 x 0.25 inch
-138	386-1903-00			4						SUPPORT, CRT, plastic
	- - - - -			-						mounting hardware for each: (not included w/support)
-139	212-0084-00			1						SCREW, 8-32 x 0.312 inch, HHS
-140	210-0805-00			1						WASHER, flat, 0.204 ID x 0.438 inch OD
	210-0069-00			1						WASHER, lock, split, 0.168 ID x 0.293 inch OD
-141	348-0006-00			1						GROMMET, rubber, 0.75 inch diameter
-142	255-0334-00			ft						PLASTIC CHANNEL, 0.187 foot long
-143	343-0123-01			2						CLAMP, electron tube retainer
	- - - - -			-						mounting hardware: (not included w/clamp)
-144	211-0600-00			1						SCREW, 6-32 x 2 inches, Fil HS
-145	220-0444-00			1						NUT, square, 6-32 x 0.25 inch
-146	343-0124-00			1						CLAMP, electron tube retainer
	- - - - -			-						mounting hardware: (not included w/clamp)
-147	211-0599-00			2						SCREW, 6-32 x 0.75 inch, Fil HS
-148	220-0444-00			2						NUT, square, 6-32 x 0.25 inch
-149	352-0091-01			2						HOLDER, electron tube retainer
	- - - - -			-						mounting hardware for each: (not included w/holder)
-150	211-0590-00			2						SCREW, 6-32 x 0.25 inch, PHB
	334-1904-00	XB190000		1						LABEL, address
	200-0799-00	XB190000		1						COVER, vinyl, resistor
	384-1034-00	XB190000		1						SHAFT, extension, 3.14 inches long
	376-0029-00	XB190000		1						COUPLING, shaft, rigid
	358-0378-00	XB190000		1						BUSHING, sleeve, front panel trim
	407-1271-00	XB190000		1						BRACKET, angle
	342-0094-00	XB190000		1						PLATE, insulator, 1.25 x 2.25 inches
	- - - - -	XB190000		-						RESISTOR, variable
	- - - - -			-						mounting hardware: (not included w/resistor)
	210-0046-00	XB190000		2						WASHER, lock, internal, 0.261 ID x 0.40 inch OD
	210-0583-00	XB190000		1						NUT, hex., 0.25-32 x 0.312 inch

FIGURE 1 FRONT (cont)

Fig. & Index No.	Tektronix Part No.	Serial/Model Eff	No. Disc	Q					Description
				t	1	2	3	4	
1-151	386-1923-00			1					SUPPORT, CRT shield, rear
	- - - - -			-					mounting hardware: <i>(not included w/support)</i>
	211-0504-00			2					SCREW, 6-32 x 0.25 inch, PHS <i>(not shown)</i>
	210-0202-00			1					LUG, solder, SE #6 <i>(not shown)</i>
	210-1092-00			2					WASHER, flat, 0.147 ID x 0.312 inch OD
-152	342-0080-00			1					INSULATOR, strip, 1 x 8.50 inches
-153	252-0571-00			ft					EXTRUSION, 0.708 foot long
-154	337-1383-00			1					SHIELD, CRT
	- - - - -			-					mounting hardware: <i>(not included w/shield)</i>
	211-0507-00			2					SCREW, 6-32 x 0.312 inch, PHS
	210-0006-00			2					WASHER, lock, internal, 0.146 ID x 0.283 inch OD

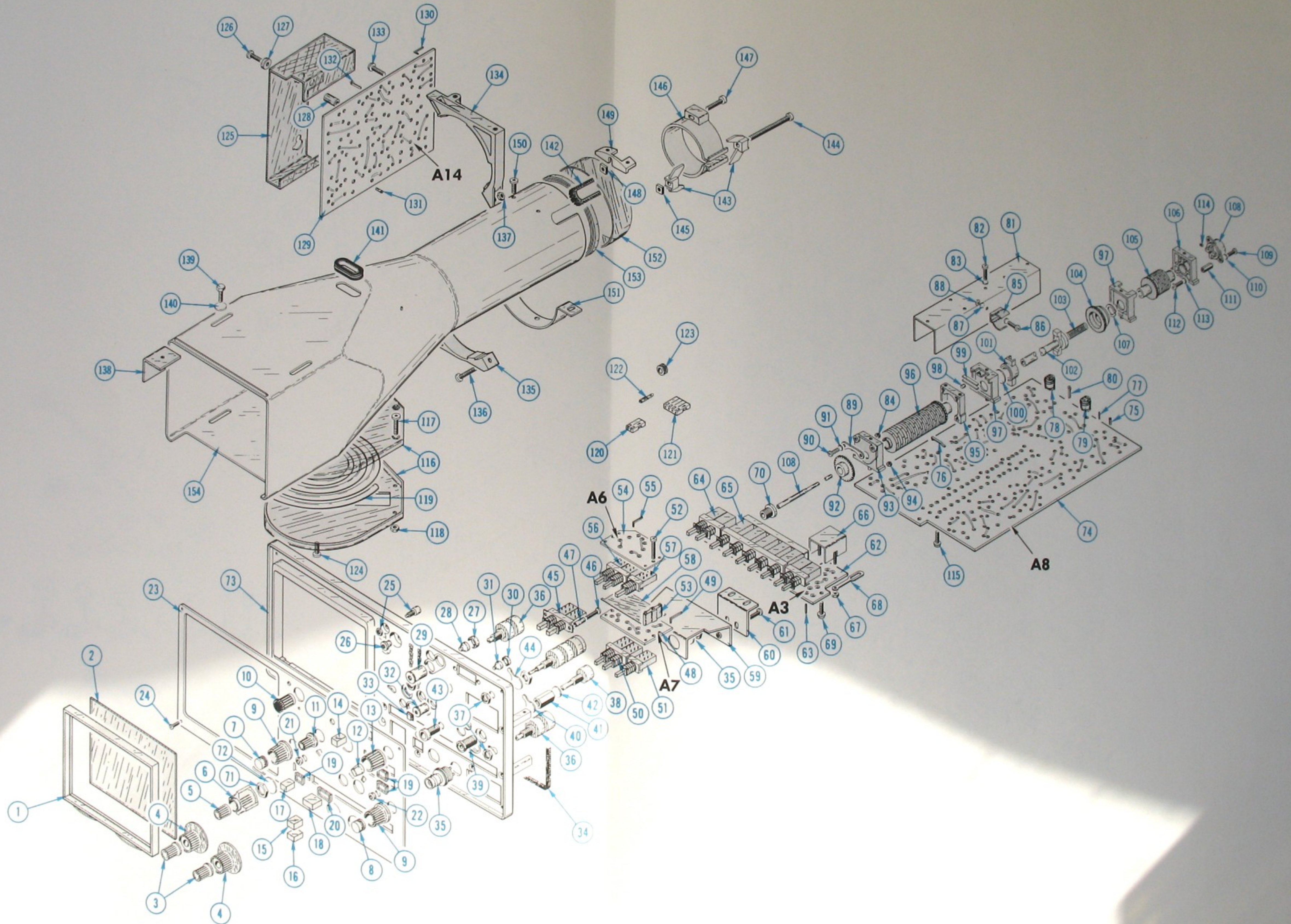

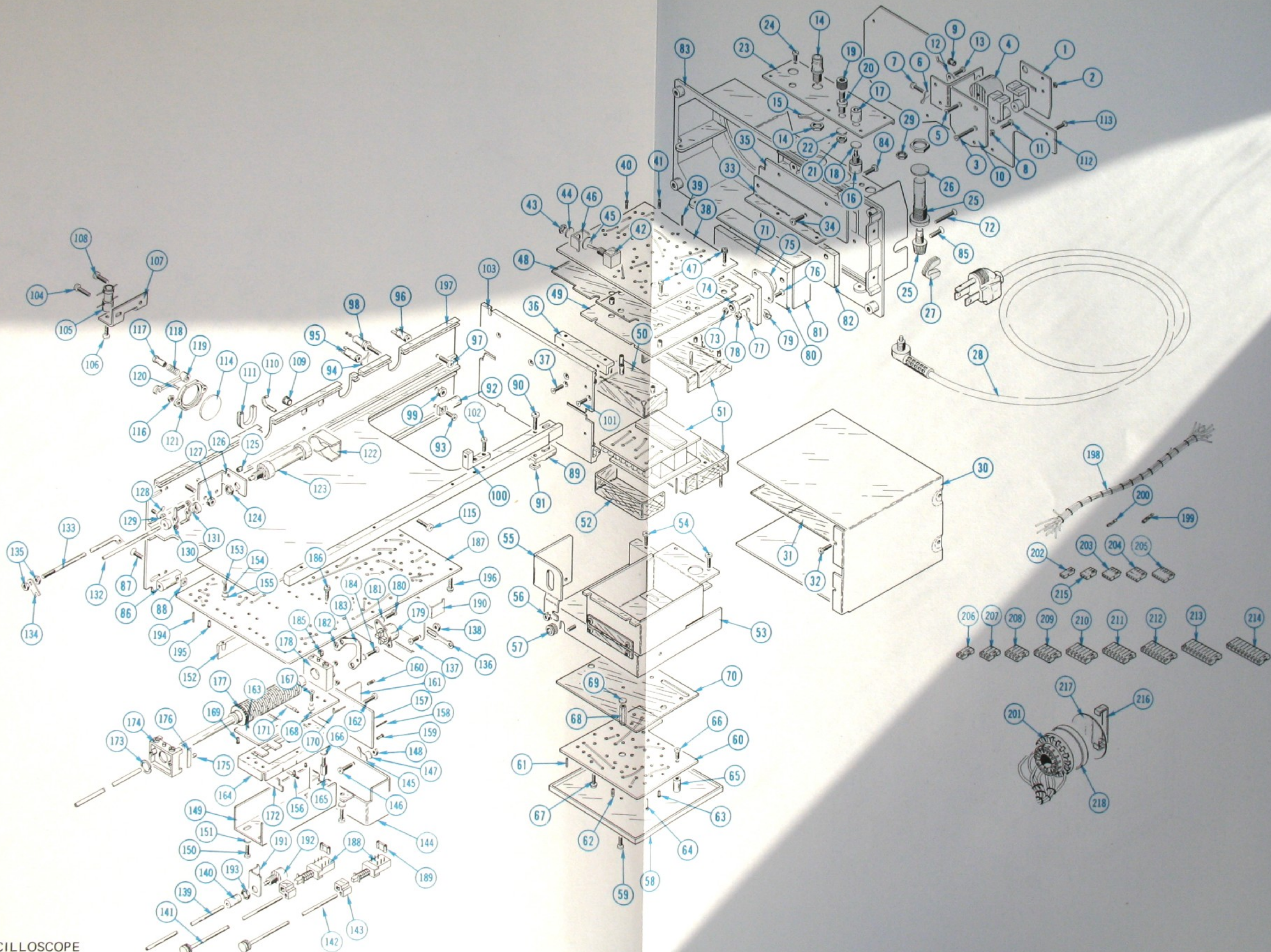

FIGURE 2 CHASSIS, REAR & STANDARD ACCESSORIES

Fig. & Index No.	Tektronix Part No.	Serial/Model No. Eff	No. Disc	Q					Description	
				†	Y	1	2	3		4
2-	119-0295-00			1						LINE FILTER ASSEMBLY
-	- - - - -			-						line filter assembly includes:
-1	388-1890-00	B010100	B149999	1						CIRCUIT BOARD—LINE FILTER A13
	388-1890-01	B150000		1						CIRCUIT BOARD—LINE FILTER A13
-	- - - - -			-						mounting hardware: (not included w/circuit board)
-2	210-0405-00			2						NUT, hex., 2-56 x 0.188 inch
-3	211-0128-00			2						SCREW, 2-56 x 1.375 inch, PHS
-4	- - - - -			1						RESISTOR
-	- - - - -			-						mounting hardware: (not included w/resistor)
-5	213-0107-00			1						SCREW, thread forming, 4-40 x 0.25 inch, 100° csk, FHS
-6	210-0201-00			2						LUG, solder, SE #4
-	- - - - -			-						mounting hardware: (not included w/lug)
-7	211-0007-00			1						SCREW, 4-40 x 0.188 inch, PHS
-8	210-0406-00			1						NUT, hex., 4-40 x 0.188 inch
-9	348-0031-00			2						GROMMET, plastic, 0.25 inch diameter
-10	441-0983-00			1						CHASSIS
-	- - - - -			-						mounting hardware: (not included w/line filter assembly)
-11	211-0007-00			2						SCREW, 4-40 x 0.188 inch, PHS
-12	- - - - -			1						SWITCH, thermostatic
-	- - - - -			-						mounting hardware: (not included w/switch)
-13	211-0008-00			2						SCREW, 4-40 x 0.25 inch, PHS
-14	131-0955-00			3						CONNECTOR, receptacle, BNC, w/hardware
-	- - - - -			-						mounting hardware for each: (not included w/connector)
-15	210-0255-00			1						TERMINAL, lug
-16	- - - - -			2						RESISTOR, variable
-	- - - - -			-						mounting hardware for each: (not included w/resistor)
-17	358-0251-00			1						BUSHING, 0.25-32 x 0.424 inch long
-18	210-0046-00			1						WASHER, lock, internal, 0.261 ID x 0.40 inch OD
-19	200-0103-00			1						NUT, knurled, 0.25-28 x 0.375 inch OD
-20	355-0507-00			1						STEM, binding post
-	- - - - -			-						mounting hardware: (not included w/stem)
-21	210-0583-00			1						NUT, hex., 0.25-32 x 0.312 inch
-22	210-0046-00			1						WASHER, lock, internal, 0.261 ID x 0.40 inch OD
-23	386-1927-00			1						PANEL, rear
-	- - - - -			-						mounting hardware: (not included w/panel)
-24	211-0007-00			6						SCREW, 4-40 x 0.188 inch, PHS
	210-0054-00			6						WASHER, lock, split #4

Mechanical Parts List—432/R432

FIGURE 2 CHASSIS, REAR & STANDARD ACCESSORIES (cont)

Fig. & Index No.	Tektronix Part No.	Serial/Model Eff	No. Disc	Q					Description	
				†	Y	1	2	3		4
2-25	352-0014-00			1						FUSEHOLDER, w/hardware
	- - - - -			-						mounting hardware: (not included w/fuseholder)
-26	210-0873-00			1						WASHER, rubber, 0.50 ID x 0.688 inch OD
-27	352-0260-00			2						HOLDER, power cord
-28	161-0033-06			1						CABLE ASSEMBLY, power
	- - - - -			-						mounting hardware: (not included w/cable assembly)
-29	210-0413-00			1						NUT, hex., 0.375-32 x 0.50 inch
	210-0012-00			1						WASHER, lock, internal, 0.375 ID x 0.50 inch OD
-30	337-1401-00	B010100	B099999	1						SHIELD, electrical
	337-1401-04	B100000		1						SHIELD, electrical
	- - - - -			-						shield includes:
-31	342-0074-00			1						INSULATOR, plate
	- - - - -			-						mounting hardware: (not included w/shield)
-32	211-0007-00			4						SCREW, 4-40 x 0.188 inch, PHS
-33	407-0935-00			1						BRACKET, angle, 3.725 inches
	- - - - -			-						mounting hardware: (not included w/bracket)
-34	211-0008-00			2						SCREW, 4-40 x 0.25 inch, PHS
-35	337-1412-00			1						SHIELD, electrical
-36	407-0934-00			1						BRACKET, angle, 2.60 inches
	- - - - -			-						mounting hardware: (not included w/bracket)
-37	211-0105-00			2						SCREW, 4-40 x 0.188 inch, 100° csk, FHS
-38	670-1349-02	B010100	B119999	1						CIRCUIT BOARD ASSEMBLY—SECONDARY POWER SUPPLY A10
	670-1349-04	B120000	B219999	1						CIRCUIT BOARD ASSEMBLY—SECONDARY POWER SUPPLY A10
	670-1349-06	B220000		1						CIRCUIT BOARD ASSEMBLY—SECONDARY POWER SUPPLY A10
	- - - - -			-						circuit board assembly includes:
	388-1908-00	B010100	B219999	1						CIRCUIT BOARD
	388-1908-02	B220000		1						CIRCUIT BOARD
-39	131-0608-00			29						TERMINAL, pin, 0.365 inch long
-40	136-0252-04			16						SOCKET, pin connector
-41	136-0263-03			9						SOCKET, terminal, pin
-42	260-0834-00			1						SWITCH, toggle, power
	- - - - -			-						mounting hardware: (not included w/switch)
-43	210-0562-00			1						NUT, hex., 0.25-40 x 0.312 inch
-44	210-0905-00			1						WASHER, flat, 0.256 ID x 0.438 inch OD
-45	210-0046-00			1						WASHER, lock, internal, 0.261 ID x 0.40 inch OD
-46	407-0936-00			1						BRACKET, component mounting
	- - - - -			-						mounting hardware: (not included w/circuit board assembly)
-47	211-0180-00			4						SCREW, sems, 2-56 x 0.25 inch, PHB
	210-1139-00			2						TERMINAL, lug, 0.99 inch ID, SE
-48	342-0068-00			1						INSULATOR, plate, circuit board
-49	441-1011-00			1						CHASSIS, circuit board

FIGURE 2 CHASSIS, REAR & STANDARD ACCESSORIES (cont)

Fig. & Index No.	Tektronix Part No.	Serial/Model No. Eff	No. Disc	Q † y	1 2 3 4 5					Description
					1	2	3	4	5	
2-50	342-0089-00			1						INSULATOR, transformer, top front
-51	- - - - -			1						TRANSFORMER
-52	342-0090-00			1						INSULATOR, transformer, bottom front
-53	337-1448-00			1						SHIELD ASSEMBLY
	- - - - -			-						mounting hardware: (not included w/shield assembly)
-54	211-0008-00			4						SCREW, 4-40 x 0.25 inch, PHS
	211-0007-00			2						SCREW, 4-40 x 0.188 inch, PHS
-55	407-0933-00			1						BRACKET, angle, power supply capacitor
	- - - - -			-						mounting hardware: (not included w/bracket)
-56	210-0586-00	B010100	B019999	3						NUT, keps, 4-40 x 0.25 inch
	210-0406-00	B020000		3						NUT, hex., 4-40 x 0.188 inch
	210-0994-00	B020000		3						WASHER, flat, 0.125 ID x 0.25 inch OD
	210-0975-00	B020000		3						WASHER, plastics, 0.14 ID x 0.375 inch OD
	210-1011-00	B020000		3						WASHER, plastic, 0.13 ID x 0.375 inch OD
-57	348-0003-00			1						GROMMET, rubber, 0.312 inch diameter
-58	337-1411-00			1						SHIELD, electrical, power supply
	- - - - -			-						mounting hardware: (not included w/shield)
-59	211-0008-00			1						SCREW, 4-40 x 0.25 inch, PHS
-60	670-1350-00			1						CIRCUIT BOARD ASSEMBLY—PRIMARY POWER SUPPLY A9
	- - - - -			-						circuit board assembly includes:
	388-1909-00			1						CIRCUIT BOARD
-61	131-0589-00			6						TERMINAL, pin, 0.50 inch long
-62	136-0263-03			9						SOCKET, pin terminal
-63	136-0252-04			39						SOCKET, pin connector
-64	214-0579-00			4						PIN, test point
-65	384-0536-00	B010100	B019999X	2						ROD, plastic
	- - - - -			-						mounting hardware for each: (not included w/rod)
-66	211-0040-00	B010100	B019999X	2						SCREW, plastic, 4-40 x 0.25 inch
	- - - - -			-						mounting hardware: (not included w/circuit board assembly)
-67	211-0180-00			3						SCREW, sems, 2-56 x 0.25 inch, PHB
-68	129-0198-00			1						POST, hex., 4-40 x 0.188 x 0.74 inch long
	- - - - -			-						mounting hardware: (not included w/post)
-69	210-0004-00			1						WASHER, lock, internal, 0.12 ID x 0.26 inch OD
	342-0162-00	XB130000		1						INSULATOR, plate, power supply
-70	342-0086-00			1						INSULATOR, plate, primary circuit board
-71	214-1527-00			1						HEAT SINK, transistor, top
	- - - - -			-						mounting hardware: (not included w/heat sink)
-72	211-0630-00			2						SCREW, 6-32 x 1.125 inches, 100° csk, FHS
-73	210-0407-00			2						NUT, hex., 6-32 x 0.25 inch
-74	342-0063-00			2						INSULATOR, bushing, plastic, 0.835 inch long
-75	- - - - -			1						TRANSISTOR
	- - - - -			-						mounting hardware: (not included w/transistor)
-76	211-0510-00			2						SCREW, 6-32 x 0.375 inch, PHS
-77	210-0202-00			1						LUG, solder, SE #6
-78	210-0457-00			2						NUT, keps, 6-32 x 0.312 inch

FIGURE 2 CHASSIS, REAR & STANDARD ACCESSORIES (cont)

Fig. & Index No.	Tektronix Part No.	Serial/Model No. Eff	No. Disc	Q † y	Description				
					1	2	3	4	5
2-79	214-1672-00			2	SPRING, helical compression, 0.25 inch long				
-80	214-1528-00			1	HEATSINK HALF, transistor, bottom				
-81	337-1451-00			1	SHIELD, electrical, primary circuit board, rear				
-82	342-0067-00			1	INSULATOR-HEATSINK, power supply				
-83	426-0708-01			1	SUBPANEL, rear				
	- - - - -			-	mounting hardware: (not included w/subpanel)				
-84	212-0023-00			1	SCREW, 8-32 x 0.375 inch, PHS				
-85	212-0040-00			2	SCREW, 8-32 x 0.375 inch, 100° csk, FHS				
-86	220-0595-00			2	NUT BLOCK, 8-32 inch thread				
	- - - - -			-	mounting hardware for each: (not included w/nut block)				
-87	211-0538-00			1	SCREW, 6-32 x 0.312 inch, 100° csk, FHS				
-88	220-0444-00			1	NUT, square, 6-32 x 0.25 inch				
-89	220-0595-00			2	NUT BLOCK, 8-32 inch thread				
	- - - - -			-	mounting hardware for each: (not included w/nut block)				
-90	211-0507-00			1	SCREW, 6-32 x 0.312 inch, PHS				
-91	220-0444-00			1	NUT, square, 6-32 x 0.25 inch				
-92	220-0595-00			1	NUT BLOCK, 8-32 inch thread				
	- - - - -			-	mounting hardware: (not included w/nut block)				
-93	211-0531-00			1	SCREW, 6-32 x 0.375 inch, Fil HS				
-94	210-0202-00			1	LUG, solder, SE #6				
-95	131-0775-00			1	TERMINAL, stud				
-96	131-0775-00	B010100	B159999	3	TERMINAL, stud				
	131-0775-00	B160000		2	TERMINAL, stud				
	- - - - -			-	mounting hardware for each: (not included w/terminal)				
-97	211-0503-00			1	SCREW, 6-32 x 0.188 inch, PHS				
	129-0069-00	XB160000		1	POST, terminal				
	- - - - -			-	mounting hardware: (not included w/post)				
	361-0008-00	XB160000		1	SPACER, plastic				
-98	129-0006-00			4	POST, connecting				
	- - - - -			-	mounting hardware for each: (not included w/post)				
-99	210-0457-00			1	NUT, keps, 6-32 x 0.312 inch				
-100	407-0884-00			1	BRACKET, angle, 2.60 inches				
	- - - - -			-	mounting hardware: (not included w/bracket)				
-101	211-0101-00			1	SCREW, 4-40 x 0.25 inch, 100° csk, FHS				
-102	211-0097-00			2	SCREW, 4-40 x 0.312 inch, PHS				
-103	337-1358-00			1	SHIELD, electrical, power supply, front				
	- - - - -			-	mounting hardware: (not included w/shield)				
-104	213-0146-00			2	SCREW, thread forming, 6-20 x 0.312 inch, PHS				

FIGURE 2 CHASSIS, REAR & STANDARD ACCESSORIES (cont)

Fig. & Index No.	Tektronix Part No.	Serial/Model No. Eff	No. Disc	Q † Y	Description				
					1	2	3	4	5
2-105	- - - - -			2	COIL				
	- - - - -			-	mounting hardware for each: <i>(not included w/coil)</i>				
-106	211-0504-00			1	SCREW, 6-32 x 0.25 inch, PHS				
-107	407-0885-00			1	BRACKET, coil				
	- - - - -			-	mounting hardware: <i>(not included w/bracket)</i>				
-108	211-0504-00			1	SCREW, 6-32 x 0.25 inch, PHS				
-109	348-0055-00			2	GROMMET, plastic, 0.25 inch				
-110	343-0089-00	B010100	B229999	2	CLAMP, cable, snap-on				
	343-0089-00	B230000		1	CLAMP, cable, snap-on				
-111	358-0215-00			3	BUSHING, plastic				
-112	386-1922-00			1	PANEL, rear				
	- - - - -			-	mounting hardware: <i>(not included w/panel)</i>				
-113	211-0065-00			7	SCREW, 4-40 x 0.188 inch, PHS				
-114	214-1138-00			2	HEATSINK, 1 inch diameter				
	- - - - -			-	mounting hardware for each: <i>(not included w/heatsink)</i>				
-115	211-0012-00			2	SCREW, 4-40 x 0.375 inch, PHS				
-116	210-0406-00			2	NUT, hex., 4-40 x 0.188 inch				
-117	210-0599-00			2	NUT, sleeve, 4-40 x 0.391 inch long				
-118	214-0368-00			1	SPRING, 0.24 inch diameter				
-119	343-0097-00			1	CLAMP, heatsink, plastic				
-120	210-0627-00			1	RIVET				
-121	352-0262-00			1	HOLDER, transistor, heatsink				
	210-0201-00			1	LUG, solder, SE #4				
-122	200-0608-00			1	COVER, variable resistor, plastic				
-123	- - - - -			1	RESISTOR, variable				
	- - - - -			-	mounting hardware: <i>(not included w/resistor)</i>				
-124	210-0562-00			1	NUT, hex., 0.25-40 x 0.312 inch				
-125	348-0031-00			1	GROMMET, plastic, 0.516 inch diameter				
-126	407-0888-00			1	BRACKET, angle, intensity control				
	- - - - -			-	mounting hardware: <i>(not included w/bracket)</i>				
-127	210-0457-00			2	NUT, keps, 6-32 x 0.312 inch				
-128	210-0201-00			1	LUG, solder, SE #4				
	- - - - -			-	mounting hardware: <i>(not included w/lug)</i>				
-129	210-0406-00			1	NUT, hex., 4-40 x 0.188 inch				
-130	376-0092-01			1	COUPLER HALF, shaft				
	- - - - -			-	coupler half includes:				
	213-0076-00			2	SETSCREW, 2-56 x 0.125 inch, HSS				

FIGURE 2 CHASSIS, REAR & STANDARD ACCESSORIES (cont)

Fig. & Index No.	Tektronix Part No.	Serial/Model No. Eff	No. Disc	Q					Description
				t	1	2	3	4	
2-131	376-0092-03			1					COUPLER HALF, shaft
	- - - - -			-					coupler half includes:
	213-0076-00			2					SETSCREW, 2-56 x 0.125 inch, HSS
-132	384-1053-00			1					SHAFT, extension, 2.741 inches long
-133	384-1083-00			1					SHAFT, extension, power switch
-134	376-0118-00			1					COUPLER, extension shaft, power switch
	- - - - -			-					mounting hardware: (not included w/coupler)
-135	210-0449-00			2					NUT, hex., 5-40 x 0.25 inch
-136	210-0288-00			1					TERMINAL, lug, 0.125 ID x 1.125 inch long
	- - - - -			-					mounting hardware: (not included w/terminal)
-137	211-0065-00			1					SCREW, 4-40 x 0.188 inch, PHS
-138	210-0586-00			1					NUT, hex., 4-40 x 0.25 inch
-139	384-1051-00			2					SHAFT, extension, 5.555 inches long
-140	376-0029-00			2					COUPLING, shaft, 0.312 x 0.50 inch long
	- - - - -			-					coupling includes:
	213-0075-00			1					SETSCREW, 4-40 x 0.094 inch long
-141	384-1052-00			1					SHAFT, extension, 8.05 inches long
-142	384-1066-00			1					SHAFT, extension, 6.20 inches long
-143	376-0114-00			2					COUPLER, plastic, pushbutton switch
	- - - - -			-					each coupler includes:
	213-0140-00			2					SETSCREW, 2-56 x 0.094 inch, HSS
-144	337-1452-00			1					SHIELD, electrical
-145	210-0201-00			1					LUG, solder, SE #4
	- - - - -			-					mounting hardware: (not included w/lug)
-146	211-0007-00			1					SCREW, 4-40 x 0.188 inch, PHS
-147	210-0004-00			1					WASHER, lock, internal, 0.12 ID x 0.26 inch OD
-148	210-0551-00			1					NUT, hex., 4-40 x 0.25 inch
	672-0019-00	B010100	B179999	1					CIRCUIT BOARD ASSEMBLY—ATTENUATOR
	672-0019-01	B180000		1					CIRCUIT BOARD ASSEMBLY—ATTENUATOR
	- - - - -			-					circuit board assembly includes:
-149	200-1199-00	B010100	B039999	2					COVER, attenuator chassis
	200-1199-01	B040000		2					COVER, attenuator chassis
	- - - - -			-					mounting hardware for each: (not included w/cover)
-150	211-0008-00	B010100	B039999	4					SCREW, 4-40 x 0.25 inch, PHS
	211-0007-00	B040000		4					SCREW, 4-40 x 0.188 inch, PHS
-151	210-0851-00	B010100	B039999	4					WASHER, flat, 0.119 ID x 0.375 inch OD
	210-0994-00	B040000		4					WASHER, flat, 0.125 ID x 0.25 inch OD
-152	337-1418-01			4					SHIELD, electrical, stiffener
	- - - - -			-					mounting hardware for each: (not included w/shield)
-153	213-0120-00			3					SCREW, thread forming, 2-32 x 0.25 inch, PHS
-154	210-0053-00			3					WASHER, lock, split, 0.092 ID x 0.175 inch OD
-155	210-1008-00			3					WASHER, flat, 0.090 ID x 0.188 inch OD

FIGURE 2 CHASSIS, REAR & STANDARD ACCESSORIES (cont)

Fig. & Index No.	Tektronix Part No.	Serial/Model No. Eff	No. Disc	Q t y	Description				
					1	2	3	4	5
2-156	670-1357-00			1	CIRCUIT BOARD ASSEMBLY—INPUT AMP A1				
	- - - - -			-	circuit board assembly includes:				
	388-1916-00			1	CIRCUIT BOARD				
-157	131-0589-00			8	TERMINAL, pin, 0.50 inch long				
-158	136-0252-04			18	SOCKET, pin connector				
-159	136-0263-03			2	SOCKET, terminal pin				
-160	337-1415-00			1	SHIELD, electrical, circuit board				
	- - - - -			-	mounting hardware: (not included w/circuit board assembly)				
-161	211-0116-00			2	SCREW, sems, 4-40 x 0.312 inch, PHB				
-162	129-0299-00			8	POST, hex., 4-40 x 0.188 x 0.333 inch long				
	- - - - -			-	mounting hardware: (not included w/circuit board assembly)				
-163	210-0004-00			1	WASHER, lock, internal, 0.12 ID x 0.26 inch OD				
-164	670-1356-00			2	CIRCUIT BOARD ASSEMBLY—ATTENUATOR (CH1-A4, CH2-A5)				
	- - - - -			-	each circuit board assembly includes:				
	388-1915-00			1	CIRCUIT BOARD				
-165	131-1031-00			8	CONTACT ASSEMBLY, top				
-166	441-0984-00	B010100	B209999	1	CHASSIS				
	441-0984-03	B210000		1	CHASSIS				
	- - - - -			-	mounting hardware: (not included w/chassis)				
-167	211-0001-00			3	SCREW, 2-56 x 0.25 inch, PHS				
	210-0053-00			3	WASHER, lock, split, 0.092 ID x 0.175 inch OD				
-168	210-1134-00			3	WASHER, flat, 0.09 ID x 0.25 inch OD				
	210-0405-00			3	NUT, hex., 2-56 x 0.188 inch				
-169	136-0252-04			8	SOCKET, pin connector				
-170	131-0590-00			1	TERMINAL, pin, 0.71 inch long				
-171	131-1030-00			8	CONTACT, electrical				
	210-0779-00			8	RIVET, 0.108 inch long				
-172	337-1406-00			1	SHIELD, electrical contact				
	263-1020-00			2	CAM SWITCH ACTUATOR ASSEMBLY				
	- - - - -			-	each switch assembly includes:				
-173	354-0391-00			1	RING, retaining				
-174	401-0081-02			1	BEARING, front				
	- - - - -			-	mounting hardware: (not included w/bearing)				
	210-0406-00			4	NUT, hex., 4-40 x 0.188 inch				
-175	214-1127-00			2	ROLLER, detent				
-176	214-1139-02			1	SPRING, flat, green				
	214-1139-03			1	SPRING, flat, red				
-177	105-0227-00			1	DRUM, cam switch				
-178	401-0113-01			1	BEARING, rear				
	- - - - -			-	mounting hardware (not included w/bearing)				
	210-0406-00			4	NUT, hex., 4-40 x 0.188 inch				
-179	- - - - -			2	RESISTOR, variable				
	- - - - -			-	mounting hardware for each: (not included w/resistor)				
-180	211-0062-00			2	SCREW, 2-56 x 0.312 inch, PHS				
-181	210-0001-00			2	WASHER, lock, internal, 0.092 ID x 0.18 inch OD				
-182	210-0405-00			2	NUT, hex., 2-56 x 0.188 inch				

FIGURE 2 CHASSIS, REAR & STANDARD ACCESSORIES (cont)

Fig. & Index No.	Tektronix Part No.	Serial/Model Eff	No. Disc	Q					Description	
				t	1	2	3	4		5
2-183	407-0900-00			2						BRACKET, variable resistor
	- - - - -			-						mounting hardware for each: <i>(not included w/bracket)</i>
-184	211-0022-00			2						SCREW, 2-56 x 0.188 inch, PHS
	210-0001-00			2						WASHER, lock, internal, 0.092 ID x 0.18 inch OD
-185	131-1157-00			4						CONTACT, electrical, ground
-186	211-0116-00			16						SCREW, sems, 4-40 x 0.312 inch, PHB
-187	670-1365-00	B010100	B029999	1						CIRCUIT BOARD ASSEMBLY—VERTICAL A2
	670-1351-01	B030000	B179999	1						CIRCUIT BOARD ASSEMBLY—VERTICAL A2
	670-1365-02	B180000		1						CIRCUIT BOARD ASSEMBLY—VERTICAL A2
	- - - - -			-						circuit board assembly includes:
	388-1924-00			1						CIRCUIT BOARD
-188	260-1236-00			2						SWITCH, push—BANDWIDTH & INVERT
	- - - - -			-						mounting hardware for each: <i>(not included w/switch)</i>
-189	361-0384-00			2						SPACER, pushbutton switch
-190	337-1413-00			1						SHIELD, electrical
	337-1459-00			1						SHIELD, electrical
-191	407-0883-00			2						BRACKET, variable resistor
-192	- - - - -			2						RESISTOR, variable
	- - - - -			-						mounting hardware for each: <i>(not included w/resistor)</i>
-193	210-0583-00			1						NUT, hex., 0.25-32 x 0.312 inch
	210-0223-00			1						TERMINAL, lug, 0.25 inch diameter, SE
	131-0566-00	XB180000		2						LINK, terminal connecting
-194	131-0589-00			52						TERMINAL, pin, 0.50 inch long
-195	136-0252-04			115						SOCKET, pin connector
	131-1031-00			8						CONTACT, ASSEMBLY, top
	210-0779-00			8						RIVET, 0.108 inch long
	- - - - -			-						mounting hardware: <i>(not included w/circuit board assembly)</i>
-196	211-0116-00			5						SCREW, sems, 4-40 x 0.312 inch, PHB
-197	426-0683-00			1						CHASSIS, main
	- - - - -			-						mounting hardware: <i>(not included w/chassis)</i>
	212-0040-00			3						SCREW, 8-32 x 0.375 inch, 100° csk, FHS <i>(not shown)</i>
-198	136-0467-00			1						WIRING HARNESS, main
	- - - - -			-						wiring harness includes:
-199	131-0621-00			88						CONNECTOR, terminal
	131-0622-00			22						CONNECTOR, terminal
-200	131-0707-00			18						CONNECTOR, terminal
	131-0708-00			2						CONNECTOR, terminal
	131-0792-00			21						CONNECTOR, terminal
-201	136-0304-02			1						SOCKET, CRT, w/contacts
-202	352-0169-00			2						HOLDER, terminal connector, 2 wire <i>(black)</i>
-203	352-0162-00			3						HOLDER, terminal connector, 4 wire <i>(black)</i>
-204	352-0163-00			2						HOLDER, terminal connector, 5 wire <i>(black)</i>
-205	352-0164-00			1						HOLDER, terminal connector, 6 wire <i>(black)</i>
-206	352-0198-00			7						HOLDER, terminal connector, 2 wire <i>(black)</i>
-207	352-0199-00			6						HOLDER, terminal connector, 3 wire <i>(black)</i>
-208	352-0200-00			2						HOLDER, terminal connector, 4 wire <i>(black)</i>
-209	352-0201-00			3						HOLDER, terminal connector, 5 wire <i>(black)</i>
-210	352-0202-00			3						HOLDER, terminal connector, 6 wire <i>(black)</i>
-211	352-0203-00			3						HOLDER, terminal connector, 7 wire <i>(black)</i>
-212	352-0204-00			1						HOLDER, terminal connector, 8 wire <i>(black)</i>
-213	352-0205-00			1						HOLDER, terminal connector, 9 wire <i>(black)</i>
-214	352-0206-00			2						HOLDER, terminal connector, 10 wire <i>(black)</i>

FIGURE 2 CHASSIS, REAR & STANDARD ACCESSORIES (cont)

Fig. & Index No.	Tektronix Part No.	Serial/Model No.		Q † Y	Description
		Eff	Disc		
2-	131-0621-00			11	CONNECTOR, terminal
	131-0865-00	B010100	B079999	4	TERMINAL, pin, S-pin, male
	131-0094-00	B080000		4	CONNECTOR, female
	131-0622-00			2	CONNECTOR, terminal
	131-0707-00			5	CONNECTOR, terminal
	131-0792-00			2	CONNECTOR, terminal
	352-0199-00			1	HOLDER, terminal connector, 3 wire (black)
-215	352-0161-00			2	HOLDER, terminal connector, 3 wire (black)
-216	343-0254-00			1	CLAMP, CRT socket
-217	367-0117-00			1	PULL, CRT socket
-218	200-0917-01			1	COVER, CRT socket

STANDARD ACCESSORIES (not shown)

010-0127-00	B010100	B039999	2	PROBE PACKAGE, P6006, 3.5 foot version
010-6061-01	B040000	B252269	2	PROBE PACKAGE, P6061, 3.50 ft. w/readout
010-6065-13	B252270		2	PROBE PACKAGE, P6065A, 6 foot
016-0165-00	XB100970		1	POUCH, accessory
070-1104-00			1	HANDBOOK, operator's
070-1103-00			1	MANUAL, instruction

FIGURE 3 CABINETS

Fig. & Index No.	Tektronix Part No.	Serial/Model No. Eff	No. Disc	Q t y	Description				
					1	2	3	4	5
3-1	200-1203-03			1	COVER, front				
-2	200-0602-00			2	COVER, handle				
-3	367-0140-01	B010100	B171389	1	HANDLE, carrying				
	367-0140-04	B171390		1	HANDLE, carrying				
	- - - - -			-	mounting hardware: (not included w/handle)				
-4	211-0512-00			4	SCREW, 6-32 x 0.50 inch, 100° csk, FHS				
-5	214-0516-00			2	SPRING, handle index				
-6	214-0513-00	B010100	B242109	2	INDEX, handle ring				
	214-0513-04	B242110		2	INDEX, handle ring				
-7	214-0515-00	B010100	B242109	2	INDEX, handle hub				
	214-0515-02	B242110		2	INDEX, handle hub				
-8	213-0139-00			2	SCREW, 10-24 x 0.375 inch, HHS				
-9	210-0805-00			2	WASHER, flat, 0.204 ID x 0.438 inch OD				
	334-1679-00			1	PLATE, identification				
-10	348-0080-01			4	FOOT, cabinet				
-11	390-0187-00	B010100	B159999	1	CABINET, wraparound				
	390-0187-01	B160000		1	CABINET, wraparound				
-12	426-0720-01			1	FRAME SECTION, cabinet				
	- - - - -			-	mounting hardware: (not included w/frame section)				
-13	212-0102-00			4	SCREW, relieved shank, 8-32 x 2 inches, PHS				
-14	348-0272-00			4	FOOT, cord wrap				
	- - - - -			-	mounting hardware for each: (not included w/foot)				
-15	213-0012-00			2	SCREW, thread forming, 4-40 x 0.375 inch, 100° csk, FHS				
-16	348-0277-00			ft	SHIELDING GASKET, electrical, 2.80 feet long				
	016-0272-00			1	RACK ADAPTER				
	- - - - -			-	rack adapter includes:				
-17	134-0067-00			5	PLUG, button, plastic				
-18	016-0120-00			1	RACKMOUNT KIT, w/hardware				
	129-0103-00			1	BINDING POST ASSEMBLY				
	- - - - -			-	binding post assembly includes:				
-19	200-0103-00			1	NUT, knurled, 0.25-28 x 0.375 inch OD				
-20	129-0077-00			1	POST, binding				
	- - - - -			-	mounting hardware: (not included w/binding post assembly)				
-21	210-0455-00			1	NUT, hex., 0.25-28 x 0.375 inch				
-22	210-0046-00			1	WASHER, lock, internal, 0.261 ID x 0.40 inch OD				
-23	437-0124-00			1	CABINET ASSEMBLY, rack adapter				
	- - - - -			-	cabinet assembly includes:				
-24	407-0250-00			2	BRACKET				
	- - - - -			-	mounting hardware for each: (not included w/bracket)				
-25	210-0458-00			4	NUT, keps, 8-32 x 0.344 inch				

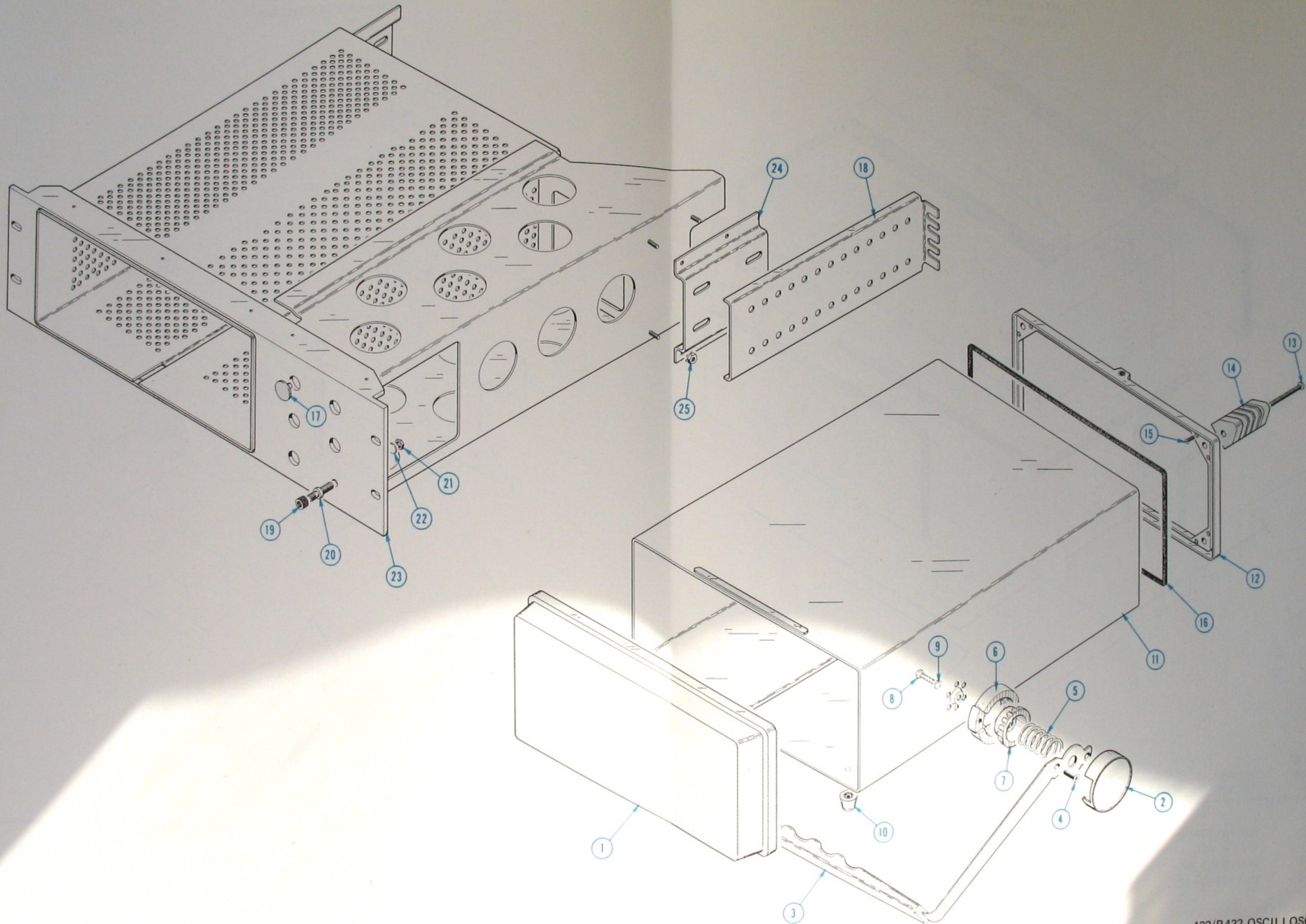

CARTON ASSEMBLY
(Part No. 065-0157-00)

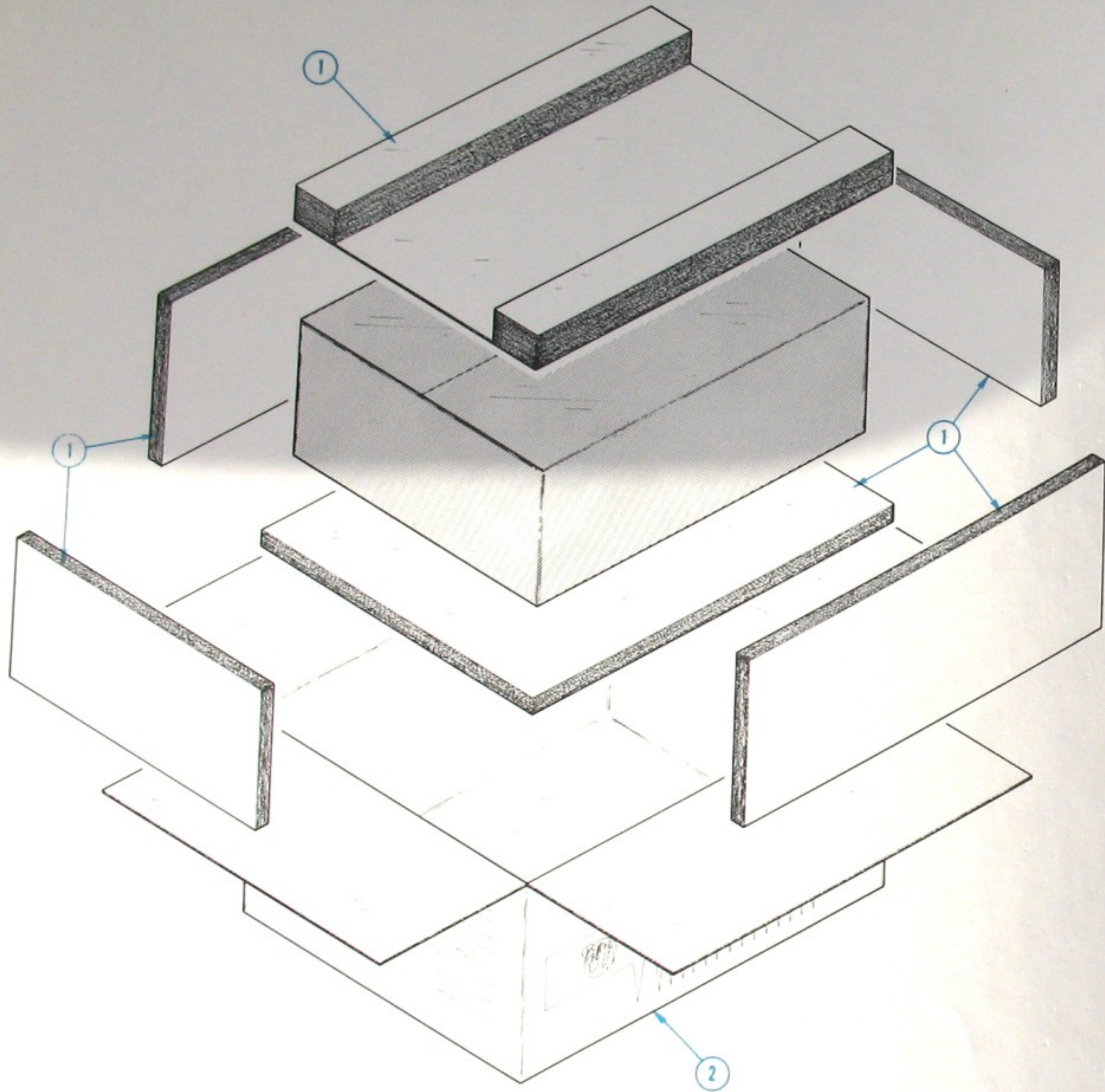

Fig. & Index No.	Tektronix Part No.	Serial/Model No. Eff	No. Disc	Q					Description	
				Y	1	2	3	4		5
4-	065-0157-00			1						CARTON ASSEMBLY
-1	004-0361-00			-						carton assembly includes:
-2	004-0461-00			1						PAD SET, 6 piece
				1						CARTON, outer

432/R432 OSCILLOSCOPE

CARTON ASSEMBLY
(Part No. 065-0157-00)

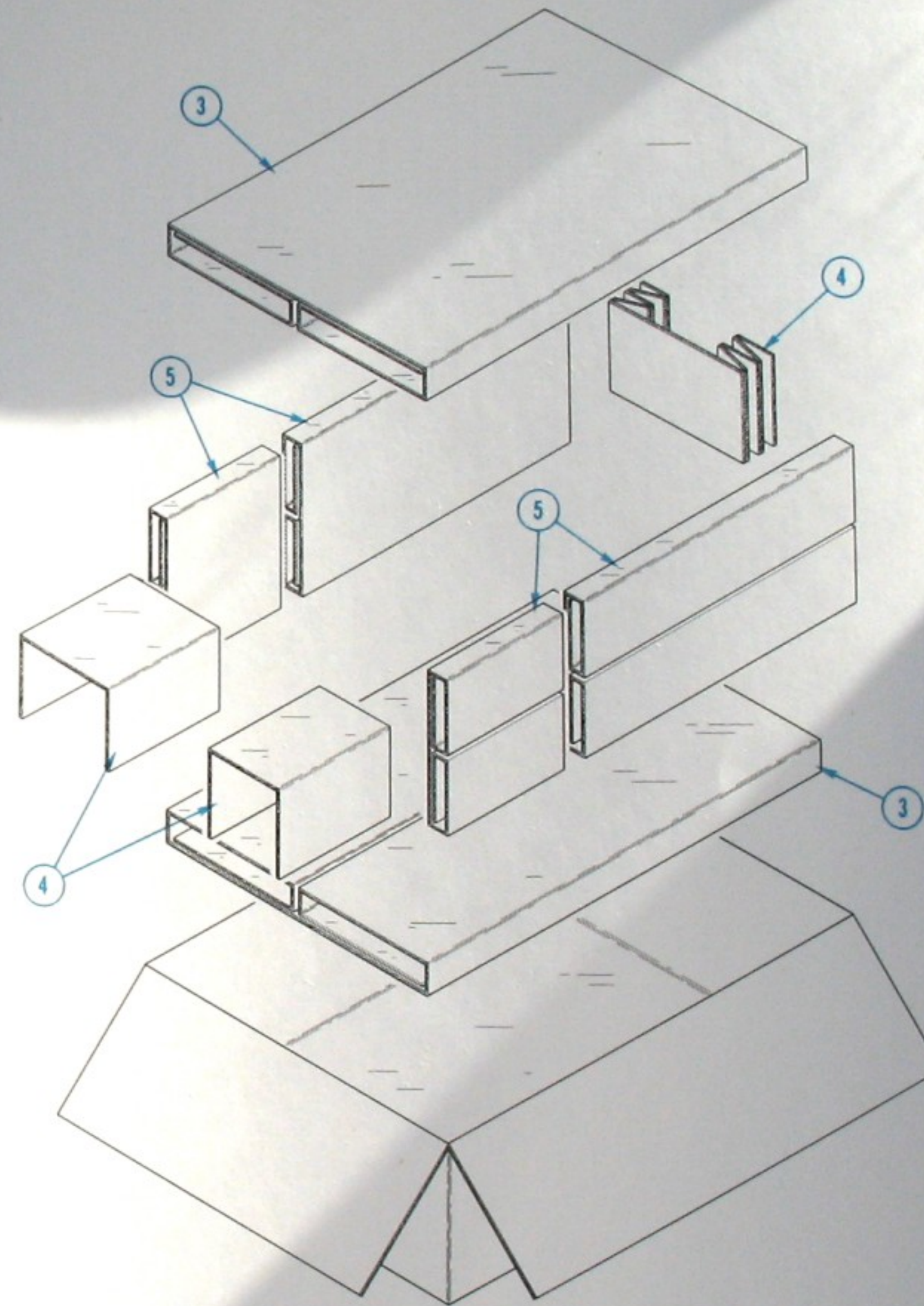

Fig. & Index No.	Tektronix Part No.	Serial/Model No. Eff	No. Disc	Q					Description	
				Y	1	2	3	4		5
-3	004-0357-00			2						PAD SET, 1 piece
-4	004-1103-00			1						PAD SET, 3 piece
-5	004-1102-00			1						PAD SET, 4 piece
-6	004-0460-00			1						CARTON, inner

CARTON ASSEMBLY
(Part No. 065-0156-00)

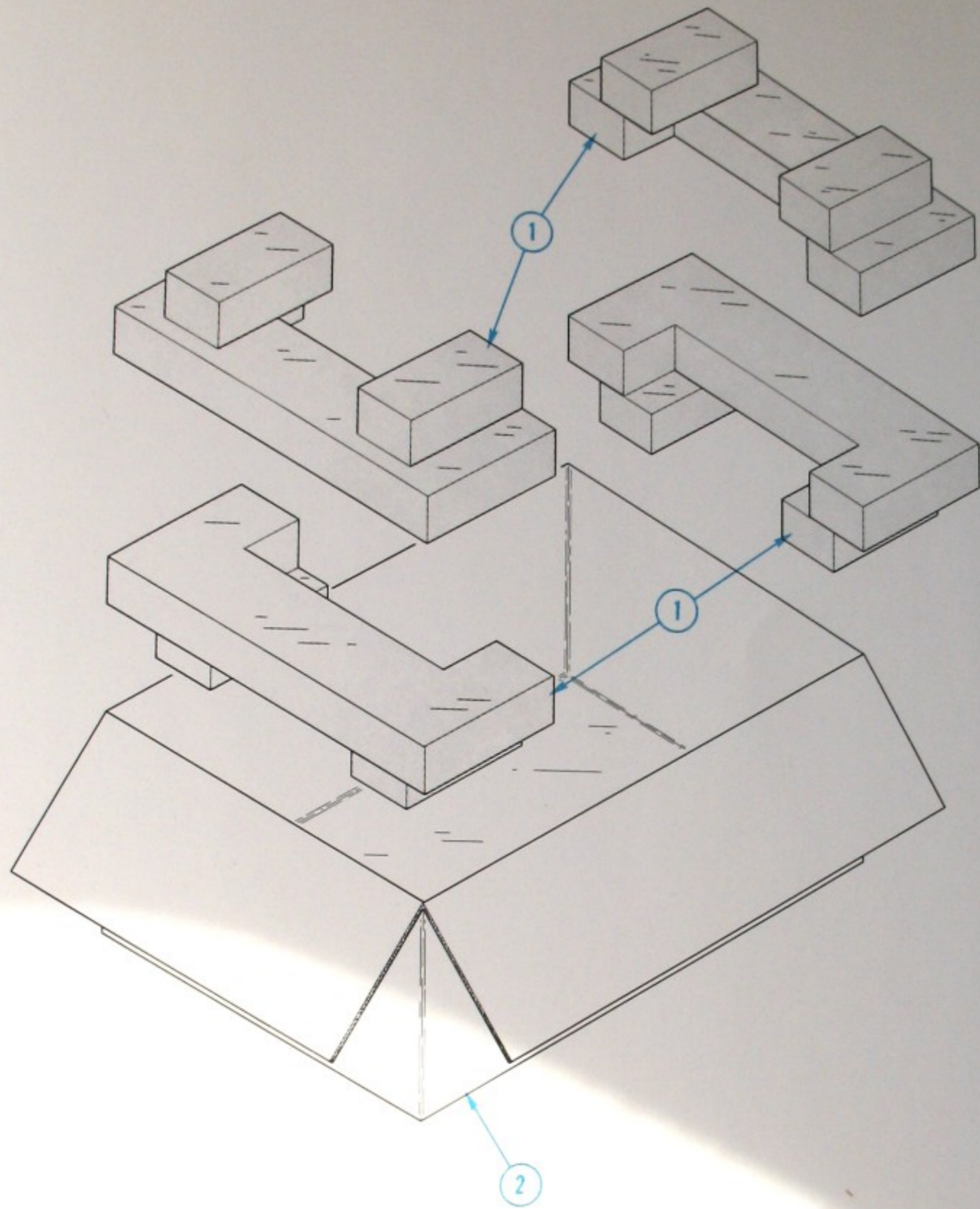

Fig. & Index No.	Tektronix Part No.	Serial/Model No. Eff	No. Disc	Q					Description	
				†	Y	1	2	3		4
5-	065-0156-00			1						CARTON ASSEMBLY
-1	004-0285-00			-						carton assembly includes:
-2	004-0704-00			2						ETHAFRAME
	004-0794-00			1						CARTON, accessory
				1						CARTON



MANUAL CHANGE INFORMATION

At Tektronix, we continually strive to keep up with latest electronic developments by adding circuit and component improvements to our instruments as soon as they are developed and tested.

Sometimes, due to printing and shipping requirements, we can't get these changes immediately into printed manuals. Hence, your manual may contain new change information on following pages.

A single change may affect several sections. Sections of the manual are often printed at different times, so some of the information on the change pages may already be in your manual. Since the change information sheets are carried in the manual until ALL changes are permanently entered, some duplication may occur. If no such change pages appear in this section, your manual is correct as printed.



MANUAL CHANGE INFORMATION

PRODUCT <u>432/R432 & 434/ R434</u> EFF SN <u>B260000-up</u>	CHANGE REFERENCE <u>M21,597</u> DATE <u>4-29-74</u>
---	--

CHANGE:	DESCRIPTION
---------	-------------

ELECTRICAL PARTS LIST CHANGE

A2 VERTICAL Circuit Board Assembly

CHANGE TO:

R230	321-0172-02	604 Ω	1/8 W	Prec	1/2%
R236	321-0172-02	604 Ω	1/8 W	Prec	1/2%
R330	321-0172-02	604 Ω	1/8 W	Prec	1/2%
R336	321-0172-02	604 Ω	1/8 W	Prec	1/2%

(Located on CH 1 & CH 2 INPUT AMPLIFIER & PREAMP diagrams 1 and 2)



TEKTRONIX®

*committed to
technical excellence*

MANUAL CHANGE INFORMATION

PRODUCT 432/R432 and

434/R434

CHANGE REFERENCE M21,597

DATE 6-6-74 ^{ADDENDUM #1}

CHANGE:

DESCRIPTION

432/R432 EFF SN B260000-up

434/R434 EFF SN B260000-up

(Affects A8 670-1359-11 HORIZONTAL Circuit Board Assembly, see diagram 6)

REMOVE:

C775 283-0003-00 0.01 μ F Cer 150 V



TEKTRONIX®

*committed to
technical excellence*

MANUAL CHANGE INFORMATION

PRODUCT GENERAL

CHANGE REFERENCE S23,351

DATE 6-10-76 REV. _____

CHANGE:

DESCRIPTION

This applies to all instruments with detachable cord.

WARNING

To avoid electrical shock or equipment damage, be sure to replace the cord set only with another of the same polarity.

Power Cord Conductor Identification

Conductor	Color	Alternate Color
Ungrounded (Line)	Brown	Black
Grounded (Neutral)	Blue	White
Grounding (Earthing)	Green-Yellow	Green-Yellow



MANUAL CHANGE INFORMATION

TEKTRONIX®
committed to
technical excellence

PRODUCT 432/R & 434/R

CHANGE REFERENCE M22,410

EFF SN B270000-up

DATE 9-13-74

CHANGE:

DESCRIPTION

ELECTRICAL PARTS LIST AND SCHEMATIC CHANGES

CHANGE TO:

DIAGRAM 11 CRT CIRCUIT & CALIBRATOR &
A14 Z AXIS Circuit Board Assembly

A14	670-1332-05	Complete Board			
C926	283-0068-00	0.01 μ F	Cer	500 V	
C940	283-0068-00	0.01 μ F	Cer	500 V	
C945	283-0068-00	0.01 μ F	Cer	500 V	
C996	290-0525-00	4.7 μ F	Elect.	50 V	20%
C998	290-0525-00	4.7 μ F	Elect.	50 V	20%
CR924	152-0413-00	Silicon	Selected from 1N4936		
CR925	152-0413-00	Silicon	Selected from 1N4936		
CR926	152-0429-00	Silicon	Selected from VG-5X		
CR928	152-0429-00	Silicon	Selected from VG-5X		
CR931	152-0429-00	Silicon	Selected from VG-5X		
CR935	152-0429-00	Silicon	Selected from VG-5X		
CR953	152-0413-00	Silicon	Selected from 1N4936		
R926	316-0471-00	470 Ω	1/4 W	10%	
R927	316-0102-00	1 K	1/4 W	10%	
R979	321-0248-00	3.74 k Ω	1/8 W	Prec	1%

REMOVE:

VR935	152-0241-00	Zener	1N973B	400 mW, 33V, 5%	
VR937	152-0241-00	Zener	1N973B	400 mW, 33V, 5%	
R925	316-0471-00	470 Ω	1/4 W	10%	
(replaced with dummy resistor)					

ADD:

W925	131-0566-00	Link, terminal connecting, dummy resistor			
------	-------------	---	--	--	--