

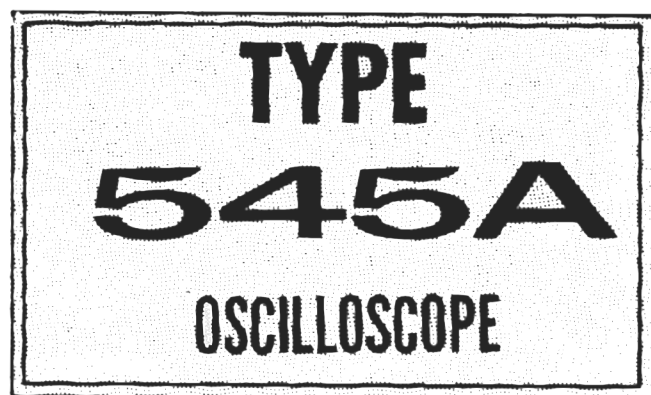

TYPE
545A
OSCILLOSCOPE

INSTRUCTION MANUAL

INSTRUCTION MANUAL



Tektronix, Inc.

S.W. Millikan Way • P. O. Box 500 • Beaverton, Oregon • Phone MI 4-0161 • Cables: Tektronix

Tektronix International A.G.

Terrassenweg 1A • Zug, Switzerland • PH. 042-49192 • Cable: Tekintag, Zug Switzerland • Telex 53.574
070-163



WARRANTY

All Tektronix instruments are warranted against defective materials and workmanship for one year. Tektronix transformers, manufactured in our own plant, are warranted for the life of the instrument.

Any questions with respect to the warranty mentioned above should be taken up with your Tektronix Field Engineer.

Tektronix repair and replacement-part service is geared directly to the field, therefore all requests for repairs and replacement parts should be directed to the Tektronix Field Office or Representative in your area. This procedure will assure you the fastest possible service. Please include the instrument Type and Serial number with all requests for parts or service.

Specifications and price change privileges reserved.

Copyright © 1960 by Tektronix, Inc., Beaverton, Oregon. Printed in the United States of America. All rights reserved. Contents of this publication may not be reproduced in any form without permission of the copyright owner.



CONTENTS

Warranty

- Section 1 **Characteristics**
- Section 2 **Operating Information**
- Section 3 **Applications**
- Section 4 **Circuit Description**
- Section 5 **Maintenance**
- Section 6 **Calibration Procedure**
- Section 7 **Accessories**
- Section 8 **Parts List and Circuit Diagrams**

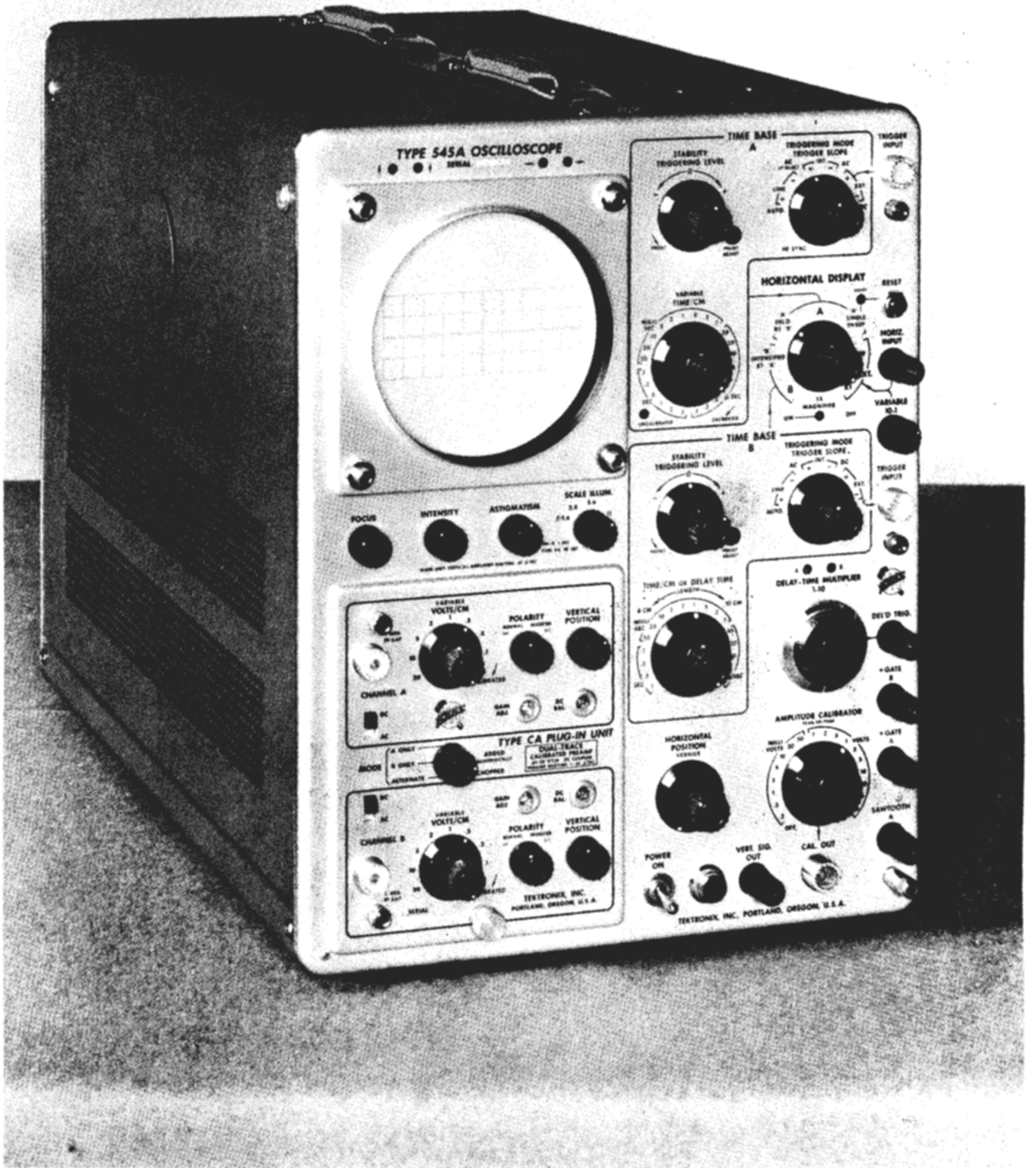

Type 545A

CHARACTERISTICS

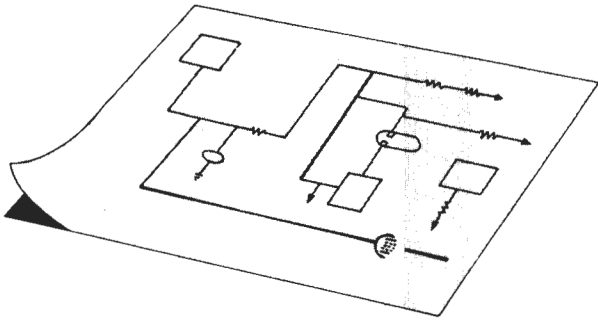

General Information

The Tektronix Type 545A Oscilloscopes are wide-range general-purpose laboratory instruments. The Type 545A provides accurate measurements in the dc to 30 mc range. The instrument can be operated with any Tektronix letter-series plug-in unit to satisfy the requirements for virtually any application.

Special circuits incorporated in the Type 545A Oscilloscope permit an accurate, continuously variable delay in the presentation of the sweep from 1 microsecond to 10 seconds after receipt of a triggering impulse. This feature permits observation of a small portion of the normal sweep, accurate measurement of waveform jitter, precise time measurements, as well as many other uses.

Vertical-Deflection System

All specifications for the Vertical-Deflection System of the Type 545A Oscilloscope depend upon the plug-in unit used with the instrument. The following specifications are given assuming that a Type K Plug-In Unit is used.

Type 545A:

Bandpass	DC to 30 mc (3 db down at 30 mc) $\pm 1/2$ db.
Risetime	0.012 microseconds

Triggering Modes

Time Base A—Automatic, AC, DC, AC Low Frequency Reject, and High Frequency Sync.

Time Base B—Automatic, AC, and DC.

Triggering Signal Requirements

Internal triggering—a signal producing 2 millimeters of vertical deflection.

External triggering—a signal of 0.2 volts to 10 volts.

Sweep will trigger on larger signals, but TRIGGERING LEVEL control operates over a ± 10 volt range.

High Frequency Sync.—Assures a stable display of sine wave signals to approximately 30 mc. Requires a signal producing 2 centimeters of vertical deflection or an external signal of more than 2 volts.

Sweep Rates

Time Base A—0.1 microseconds to 5 seconds per centimeter in 24 accurately calibrated steps. An uncalibrated control permits sweep rates to be varied continuously between 0.1 microseconds and approximately 12 seconds per centimeter.

Calibrated sweep rates are typically within 1%, and in all cases within 3%, of the indicated sweep rate.

Time Base B—2 microseconds to 1 second per centimeter in 18 accurately calibrated steps. Sweep rates are typically within 1%, and in all cases within 3%, of the indicated sweep rate.

Magnifier

Provides a 5-times magnification of the center 2-centimeter portion of the oscilloscope display. Extends the fastest Time Base A sweep rate to 0.02 microseconds per centimeter and the fastest Time Base B sweep rate to 0.4 microseconds per centimeter.

External Horizontal Input

Deflection factor—approximately 0.2 to 15 volts per centimeter, continuously variable.

Frequency response—from dc to 240 kc. Response down 3 db at 240 kc.

Horizontal input connector characteristics—1 megohm paralleled by approximately 55 μ f.

Delayed Sweep

Sweep delay continuously variable from 1 microsecond to 10 seconds. Actual delay steps (between 1.00 and 10.00) are within 1% of the indicated delay from 2 μ sec/cm to 0.1 sec/cm; within 3% from 0.2 sec/cm to 1 sec/cm. Incremental delay accuracy is within 0.2%.

Time jitter—1 part in 20,000.

Cathode-Ray Tube

Type 545A Oscilloscope—Type T543P2.

Phosphors—Type P2 phosphor normally supplied; P1, P7, and P11 phosphors optional. Other phosphors available on special order.

Unblanking—dc coupled.

Characteristics — Type 545A

Accelerating potential—10,000 volts.

Usable viewing area:

Type 545A Oscilloscope—4 by 10 centimeters.

Line voltage requirements—105 to 125 volts, or 210 to 250 volts.

Power—approximately 500 watts with a Type CA Plug-In Unit installed.

Line frequency—50 to 60 cycles.

Graticule

Illumination—variable edge lighting.

Type 545A graticule markings—marked in 4 vertical and 10 horizontal 1-centimeter divisions with 2-millimeter markings on the centerlines.

Amplitude Calibrator

Waveform—square-waves at approximately 1,000 cycles.

Output voltage—0.2 millivolts peak-to-peak to 100 volts peak-to-peak in 18 steps.

Accuracy—peak-to-peak amplitudes of square-waves within 3% of indicated voltage.

Output Waveforms Available

Delayed trigger pulse—approximately 5 volts in amplitude, occurring at the end of the delay period.

Positive Gate B—approximately 20 volts peak-to-peak with same duration as sweep B.

Positive Gate A—approximately 20 volts peak-to-peak with same duration as sweep A.

Sawtooth A—sweep A sawtooth waveform, approximately 150 volts peak.

Vertical signal output—output from vertical deflection system. Approximately 1.5 volts peak-to-peak per centimeter of vertical deflection.

Power Supplies

Electronically regulated for stable operation with widely varying line voltages and loads.

Ventilation

Forced filtered air. Thermal relay interrupts instrument power in the event of overheating.

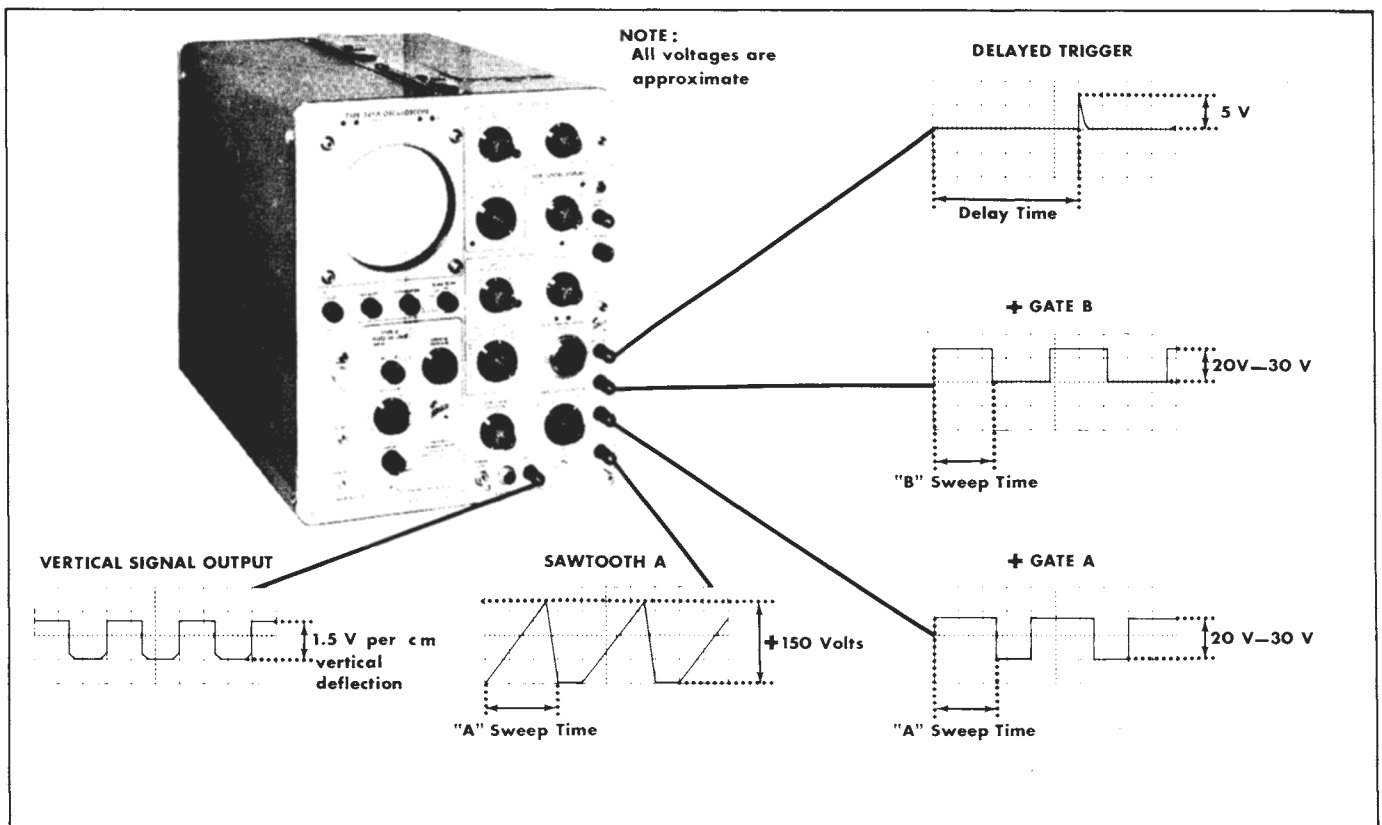

Fig. 1-1. Output waveforms available at the Oscilloscope front panel.

Construction

Aluminum-alloy chassis and three-piece cabinet. Photo etched anodized panel, blue wrinkle-finished cabinet.

Dimensions—see Figure 1-2.

Weight—65 pounds.

Accessories

- 1—3 to 2-wire Adapter, 103-013
- 2—Type 6000 Probes, 010-020
- 2—Type A510 Binding-Post Adapters, 013-004
- 1—Test Lead (012-031).
- 1—Type F510-5 Green Filter (378-514).
- 2—Operator's Manuals.
- 1—Operator's Handbook.
- 1—3-conductor power cord, 161-010

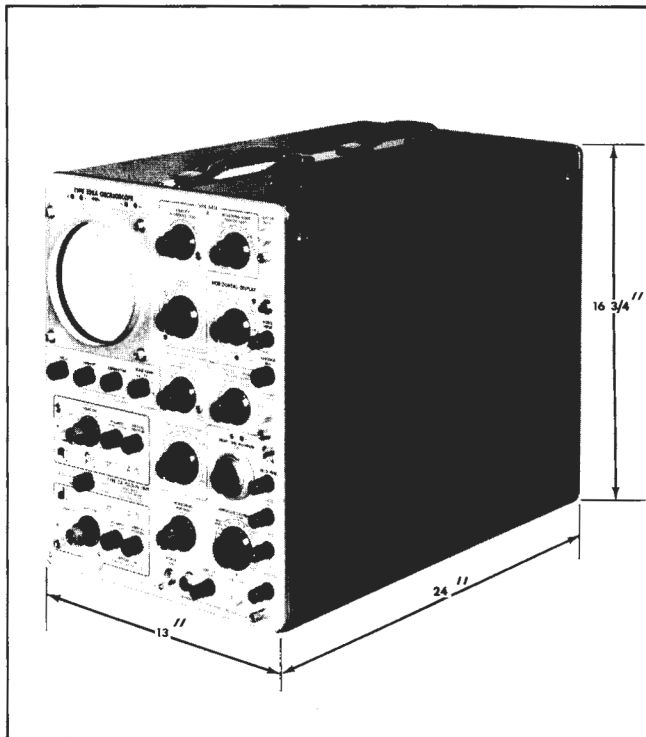

Fig. 1-2. Type 545A Oscilloscope Dimensions.

Type N

The Type N Sampling Unit is designed for use with Tektronix plug-in type Oscilloscopes. The sampling system thus formed permits the display of repetitive signals with fractional nanosecond (10^{-9} second or nsec) risetime. By taking successive samples at a slightly later time at each recurrence of the pulse under observation, the Type N reconstructs the pulse on a relatively long time-base. Specifications of the Type N include a risetime of 0.6 nsec, corresponding to a maximum bandpass of approximately 600 mc; a sensitivity of 10 mv/cm with 2 mv or less noise; and a dynamic range of ± 120 mv minimum linear range before overloading results.

Accidental overload of ± 4 volts dc is permissible.

Type P

The Type P Plug-In Unit generates a fast-rise step-function test signal of known waveform, simulating the output of an ideally compensated Type K Unit driven with a Tektronix Type 107 Square-Wave Generator. The Type P permits the standardization of the main-unit vertical amplifier transient response of a Tektronix convertible oscilloscope. Risetime of the Type P is approximately 4 nanoseconds when it is used to standardize a Type 540-Series Oscilloscope. Pulse repetition rate is 240 step functions per second, with either positive or negative polarity. Step function amplitude is continuously adjustable between 0 and 3 major graticule divisions.

Type Q

The Type Q Plug-In Unit permits any Tektronix convertible oscilloscope such as the Type 545A to be operated with strain gages and other transducers. Excitation voltages for the strain gages and transducers are provided by the plug-in unit. The unit provides high gain, low noise, and extremely low drift. Frequency response of the Type Q Plug-In Unit is DC to 6 kc; risetime is approximately 60 microseconds. Strain sensitivity is calibrated in 10 steps from 10 microstrain per major graticule division to 10,000 microstrain per division, and is continuously variable between steps.

Type R

The Type R Plug-In Unit is a combined power supply and pulse generator which is used to measure the high-frequency characteristics of junction transistors by the pulse-response method. When the Type R is used in an oscilloscope having a delay line; delay time, risetime, storage time, and fall-time may be displayed simultaneously. A pushbutton switch connects a front-panel terminal directly to the input of the oscilloscope for observing externally derived waveforms.

Pulse risetime of the Type R unit is less than 5 nanoseconds, so measurements depend on the risetime of the oscilloscope used. Pulse amplitudes are in 8 fixed, calibrated steps from .05 to 10 volts, adjustable between steps. Pulse recurrence frequency is 120 pulses per second.

Type S

The Type S Plug-In Unit is designed for use with Tektronix Wide-Band convertible oscilloscopes. The slower risetime of the Tektronix 530-Series Oscilloscopes will affect the ability of the S Unit to analyze fast semiconductor diodes. Using the Type S, voltage across a test diode is displayed as a function of time.

Certain diode parameters, such as junction resistance, junction capacitance, and the stored charge at the junction, can be measured readily and reliably from the display. Performance of a diode in a particular circuit can be predicted by analyzing the recovery and "turn-on" characteristics. Since it is essentially a means for plotting voltage across an element while passing constant current through it, the unit can be used for other applications as well. For

Characteristics — Type 545A

PLUG-IN PREAMPLIFIER CHARACTERISTICS FOR TYPE 545A OSCILLOSCOPES

PLUG-IN TYPE	CALIBRATED DEFLECTION FACTOR	PASSBAND	RISETIME	INPUT CAPACITANCE
Type A Wide-Band DC Coupled	0.05 v/cm to 20 v/cm	dc to 14 mc dc to 20 mc	18 nsec	47 pf
TYPE B Wide-Band High Gain DC Coupled	5 mv/cm to 0.05 v/cm 0.05 v/cm to 20 v/cm	2 c to 12 mc dc to 20 mc	30 nsec 18 nsec	47 pf
TYPE CA Dual-Trace DC Coupled	0.05 v/cm to 20 v/cm	dc to 24 mc	15 nsec	20 pf
TYPE D High-Gain DC Coupled Differential	1 mv/cm to 50 v/cm	dc to 2 mc	0.18 μ sec	47 pf
Type E Low-Level AC Coupled Differential	50 μ v/cm to 10 mv/cm	0.06 cycles to 60 kc	6 μ sec	50 pf
TYPE G DC Coupled Differential Wide-Band	0.05 v/cm to 20 v/cm	dc to 20 mc	18 nsec	47 pf
TYPE H DC Coupled High-Gain Wide-Band	5 mv/cm to 20 v/cm	dc to 15 mc	23 nsec	47 pf
TYPE K Fast-Rise DC Coupled	0.05 v/cm to 20 v/cm	dc to 30 mc	12 nsec	20 pf
TYPE L Fast-Rise High-Gain DC Coupled	5 mv/cm to 2 v/cm 0.05 v/cm to 20 v/cm	3 c to 24 mc dc to 30 mc	15 nsec 12 nsec	20 pf
TYPE N* Pulse Sampling	10 mv/cm	600 mc	0.6 nsec	Input Impedance 50 ohms
TYPE P* is a fast-rise step-function test signal unit.				
TYPE Q* Strain Gage	10 μ strain/div to 10,000 μ strain/div	dc to 6 kc	60 μ sec	Adjustable
TYPE R* Transistor Risetime	0.5 ma/cm to 100 ma/cm		12 nsec	
TYPE S* Semiconductor Diode Recovery	0.05 v/cm and 0.05 v/cm			
TYPE T* Time-Base Generator				
TYPE Z* DC Coupled Differential Comparator	0.05 v/cm to 25 v/cm	dc to 13 mc	27 nsec	27 pf

*More data available on the special purpose plug-in units in the following paragraphs.

example: observing the junction characteristics of transistors, or measuring the resistance, capacitance or inductance of circuit components.

The Type S offers calibrated forward currents in five fixed steps from 1 to 20 milliamps, and reverse currents calibrated in six steps from 0 to 2 milliamps. Diode shunt capacitance is 9 picofarads, and deflection factors are 0.05 v/cm and 0.5 v/cm, calibrated.

Type T

The Type T Time-Base Generator provides sawtooth sweep voltages from 0.2 μ sec/div to 2 sec/div. The trigger source may be line frequency, external, ac or dc coupled, automatic or high-frequency sync. The triggering point can be on either rising or falling slope of the waveform, and triggering level is adjustable. A signal of 0.2 to 50 volts is required for triggering.

Type Z

The Type Z Plug-In Unit extends the accuracy of oscilloscope voltage measurements. It can be used in three modes of operation: (1) as a conventional preamplifier, (2) as a differential input preamplifier, or (3) as a calibrated differential comparator. With sensitivity of 50 mv/cm and insertion voltage range of ± 100 volts, the effective scale range is ± 2000 cm. Maximum resolution of the Type Z Unit is .005%.

As a conventional preamplifier, the Type Z Unit offers a passband of dc to 13 mc for the 545A for signals that do not overscan the screen. The deflection factors are 0.05 volts/cm to 25 v/cm in 9 fixed, calibrated steps.

As a differential input preamplifier, the Type Z accepts a common-mode signal level ± 100 volts with input attenuation X1, and offers a common-mode rejection ratio of 40,000 to 1. Maximum input signal is 1 volt/7 nsec, or —1 volt/5 nsec.

As a calibrated differential comparator, the Type Z makes available three comparison voltage ranges; from zero to ± 1 volt, zero to ± 10 volts, zero to ± 100 volts.

SECTION 2

OPERATING INSTRUCTIONS

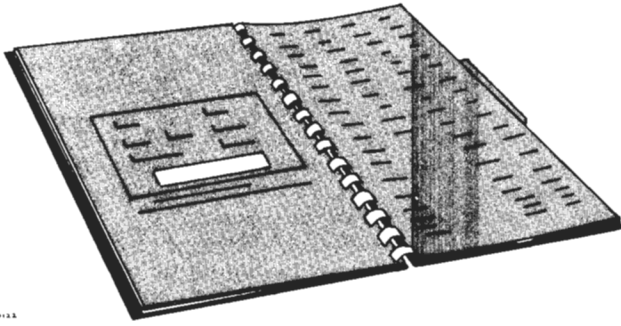

The Type 545A Oscilloscope is an extremely versatile instrument which is adaptable to a great number of applications. However, to make use of the full potentialities of the instrument, it is necessary that you understand completely the operation of each control. This portion of the Instruction Manual is intended to provide you with the basic information that you require. If you are familiar with other Tektronix Oscilloscopes, you should have very little difficulty in understanding the operation of the Type 545A since the function of many controls is the same as the function of corresponding controls on other Tektronix instruments.

Plug-In Units

The Type 545A Oscilloscope is designed to operate with any one of the Tektronix letter-series plug-in units. The particular plug-in unit used must be selected by you to satisfy the requirements of your application. In selecting the plug-in unit for any particular application, you must consider the bandpass, sensitivity, and the type of input required for that application. The plug-in units available will satisfy the requirements for most applications.

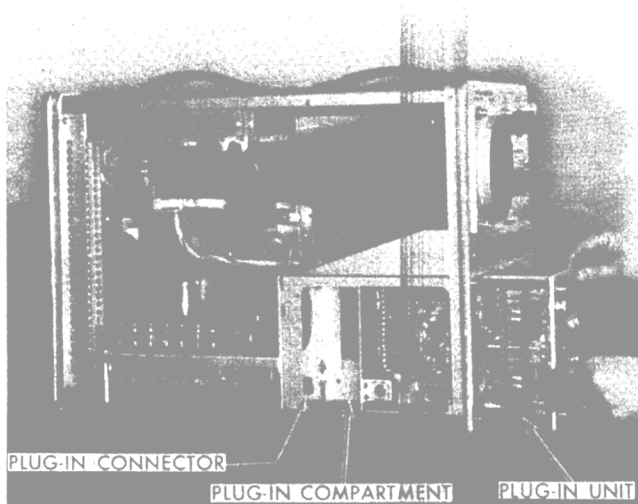

Fig. 2-1. Inserting the selected plug-in unit into the oscilloscope plug-in unit compartment.

Preparation for use

When the plug-in unit has been selected, insert it into the plug-in compartment of the oscilloscope and press firmly to insure that the connectors make proper contact (see Figure 2-1). Tighten the plug-in unit locking control to hold the unit securely in place and turn the oscilloscope INTENSITY control fully counterclockwise. Connect the power cord to the rear of the instrument and to the power line and place the POWER switch in the ON position.

Time Delay

Time delay relays used in Type 545A Oscilloscopes delay operation of the instrument for approximately 25 seconds after the POWER switch is turned on to allow a brief tube-warmup period. The delay allows the tubes sufficient time to heat before the dc operating voltages are applied.

If the ac power is off for only an instant, the normal 25-second delay will occur before the instrument returns to full operation. This delay will occur regardless of whether the ac power is off because of a momentary power failure or is turned off with the POWER switch.

Focus and Astigmatism Controls

The FOCUS and ASTIGMATISM controls operate in conjunction with each other to allow you to obtain a sharp, clearly defined spot or trace. The proper setting of the ASTIGMATISM control is obtained by rotating the FOCUS control fully clockwise, setting the HORIZONTAL DISPLAY switch to EXT. X10, and adjusting the INTENSITY control to obtain a spot on the screen. After positioning the spot to the center of the screen, the ASTIGMATISM control is adjusted for the most nearly circular spot possible. The FOCUS control is then adjusted to reduce the spot diameter as much as possible. (You must be certain that all input signals to the oscilloscope are disconnected when you adjust the FOCUS and ASTIGMATISM controls.)

Intensity Control

The INTENSITY control is used to adjust the brightness of the oscilloscope display. This permits you to compensate for changes in brightness resulting from changes in the sweep or triggering rate. The INTENSITY control is rotated clockwise to increase brightness and counterclockwise to decrease brightness. Care must be taken when using the INTENSITY control that the brightness is not turned up to

the point where the face of the cathode-ray tube is permanently damaged. If the intensity of the beam is turned up too far, the phosphor on the face of the crt may be burned. The intensity of the beam should never be turned up to the point where a halo forms around the spot.

Graticule Illumination Control

The graticule used with the Type 545A Oscilloscope is accurately marked with 10 horizontal and 4 vertical 1-centimeter divisions with 2-millimeter markings on the center-lines. These graticule markings allow you to make time and voltage measurements from the oscilloscope screen.

The graticule is illuminated by two lamps located at the top edge of the graticule. This illumination can be controlled so that the graticule markings appear either red or white, as desired. The graticule markings are changed from red to white or from white to red by removing the graticule cover and rotating the graticule through 180° about an axis through the center of the graticule (see Figure 2-2). As a general rule, white graticule markings are superior to red for photographic purposes.

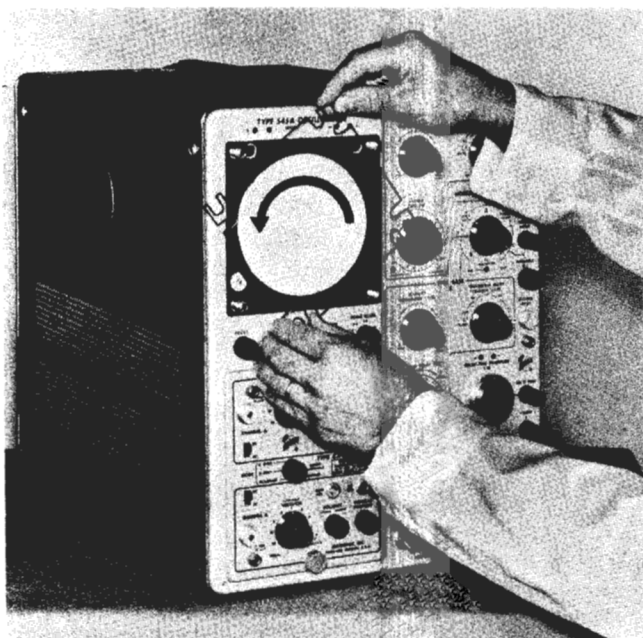

Fig. 2-2. Rotating the graticule to change the color of the graticule markings from red to white or from white to red.

Graticule illumination is adjusted by the SCALE ILLUM control located just under the oscilloscope screen. Rotating the control clockwise increases the brightness of the graticule markings and rotating the control counterclockwise decreases the brightness. For convenience in photographic work, the SCALE ILLUM control is marked in approximate f-stops. These f-stops can be used with a shutter speed of 1 second when TRI-X film is used or with a shutter speed of 10 seconds when Type 44 Polaroid film is used. Regardless of the type of film used, white graticule markings should be used. To obtain satisfactory waveform photographs, the intensity of the trace must approximately match the brightness of the graticule markings.

Positioning Controls

Three controls are used with the Type 545A Oscilloscope to allow you to position the trace to the desired point on the oscilloscope screen. Two of these controls are used to set the horizontal position of the trace and are located on the front panel of the instrument. The third control is used to set the vertical position of the trace and is located on the front panel of the plug-in unit used with the oscilloscope. (The Type 53/54C and Type CA Dual-Trace Plug-In Units have two Vertical Positioning controls.)

The two HORIZONTAL POSITION controls cause the trace to move to the right when they are rotated in the clockwise direction and to the left when they are rotated counterclockwise. The combination of the two controls has a total positioning range of approximately 12 centimeters with the sweep magnifier off or approximately 60 centimeters with the sweep magnifier on. The black HORIZONTAL POSITION control has approximately three times the range of the red VERNIER control. The fine range of adjustment of the VERNIER control makes this control particularly useful whenever fine horizontal positioning is required, as for example, when the sweep magnifier is used.

The vertical positioning control has sufficient range to allow the trace to be positioned completely off the top or bottom of the screen or to any intermediate point. The trace moves up when the control is rotated clockwise and down when the control is rotated counterclockwise.

Beam Position Indicators

Four small indicator lights located just above the oscilloscope screen indicate the position of the spot or trace. When one of these lamps is lit, it indicates that the trace is off-centered in the direction of the arrow. These four lights allow you to position the spot to the center of the screen even though the intensity is so low that the trace is not visible. When the sweep is running, the spot moves from the left side of the screen to the right and may cause both horizontal lamps to light each time the sweep runs.

Input Signal Connections

The electrical waveform to be observed is applied to one of the plug-in unit input connectors. The waveform is then connected through the vertical-deflection system of the plug-in unit and the oscilloscope to cause the spot to be deflected vertically and to trace out the waveform on the screen of the crt. The vertical size of the displayed waveform is adjusted with the plug-in unit VOLTS/CM switch. The VOLTS/CM switch is an accurately calibrated control which, when used with the graticule, allows you to make precise voltage measurements from the displayed waveforms. The operation of other plug-in unit controls varies between plug-in units. For information regarding the operation of these controls, refer to the instruction manual for the plug-in unit you are using.

Certain precautions must be taken when you are connecting the oscilloscope to the input signal source to insure that accurate information is obtained from the oscilloscope display. This is particularly true when you are observing low-level signals or waveforms containing high- or extremely

low-frequency components. For applications where you are observing low-level signals, unshielded input leads are entirely unsatisfactory due to their tendency to pick up stray signals which produce erroneous oscilloscope displays. Shielded cables should be used whenever possible, with the shield connected to the chassis of both the oscilloscope and the signal source. Regardless of the type of input lead used, leads should be kept as short as possible.

Distortion of the input waveform may result if very low-frequency input signals are ac coupled into the oscilloscope, if high-frequency waveforms are not properly terminated, or if the input waveform contains high-frequency components which exceed the pass band of the oscilloscope and plug-in unit combination. You must be aware of the limitations of the instrument.

In analyzing the displayed waveform, you must consider the loading effect that the oscilloscope has on the input-signal source. In most cases this loading effect is negligible; however in some applications, loading caused by the oscilloscope may materially alter the results obtained. In such cases you may wish to reduce the amount of loading to a negligible amount through the use of a probe.

Use of Probes

Occasionally connecting the input of an oscilloscope to a signal source loads the source sufficiently to adversely affect both the operation of the source and the waveform displayed on the oscilloscope. In such cases an attenuator probe may be used to decrease both the capacitive and resistive loading caused by the oscilloscope to a negligible value.

In addition to providing isolation of the oscilloscope from the signal source, an attenuator probe also decreases the amplitude of the displayed waveform by the attenuation factor of the probe. Use of a probe allows you to increase the vertical-deflection factors of the oscilloscope to observe large-amplitude signals which are beyond the normal limits of the oscilloscope and plug-in combination. Signal amplitudes, however, must be limited to the maximum allowable value of the probe used.

Before using a probe you must check (and adjust if necessary) the compensation of the probe to prevent distortion of the applied waveform. To adjust the probe compensation control, place the HORIZONTAL DISPLAY switch to A, the

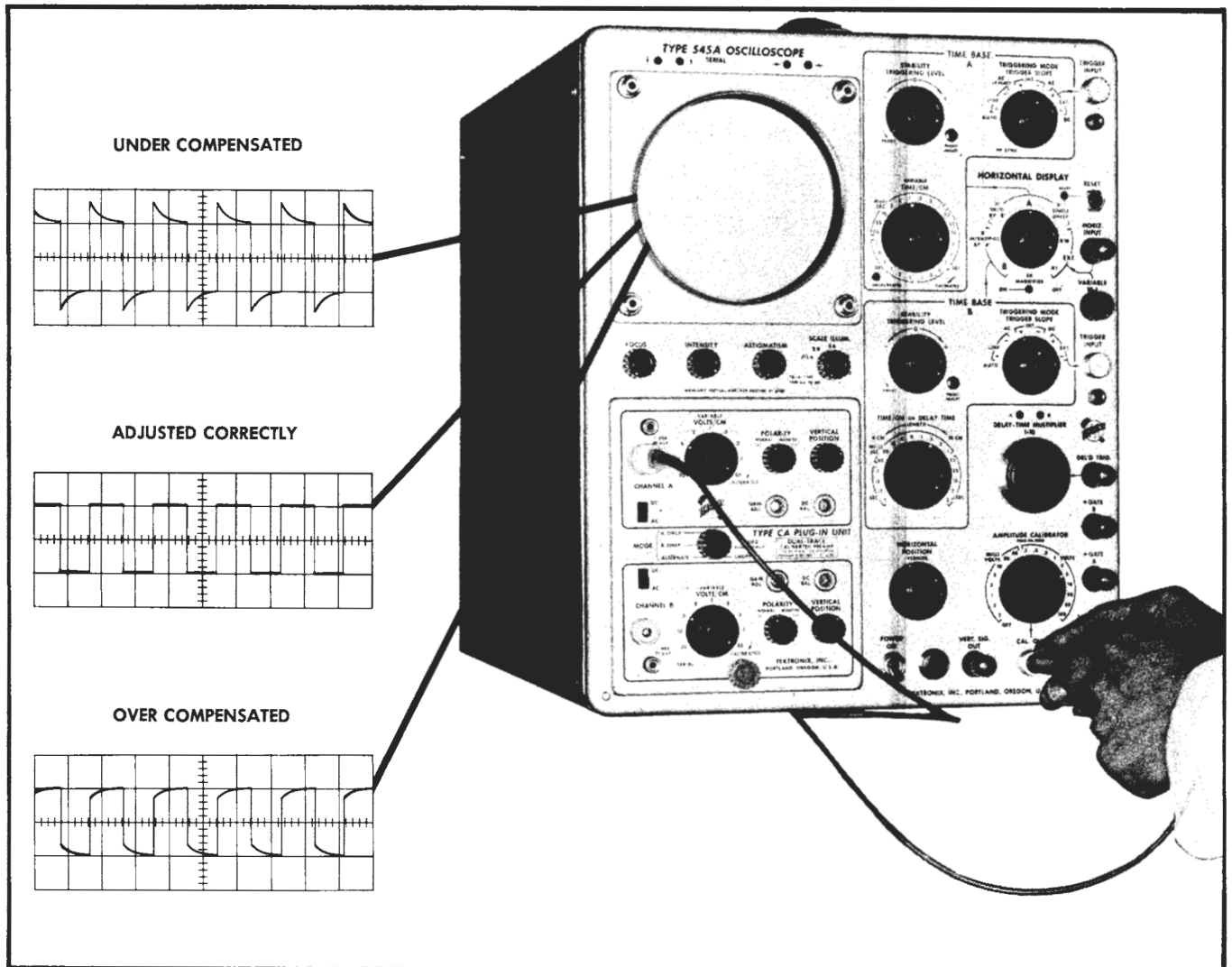

Fig. 2-3. When compensating the probe it is adjusted to obtain an undistorted presentation of the calibrator square-waves.

Operating Instructions — Type 545A

TIME BASE A TRIGGERING MODE switch to AUTO, and the TIME BASE A TRIGGER SLOPE switch to +INT. Turn up the intensity until the trace is visible and connect the probe tip to the CAL OUT connector. Set the AMPLITUDE CALIBRATOR switch for 2 centimeters of displayed signal. Set the TIME BASE A TIME/CM switch to display approximately 3 or 4 cycles of the Calibrator waveform and adjust the probe compensation control to obtain flat tops on the displayed Calibrator square-waves (see Figure 2-3).

First unlock the Locking Sleeve by turning it counter-clockwise. The probe is then compensated by rotating the probe body while watching the oscilloscope display for the desired waveform. When compensation is completed, carefully turn the Locking Sleeve clockwise to lock it without disturbing the adjustment of the probe.

Horizontal Sweep

The usual oscilloscope display is a graphical presentation of instantaneous voltage versus time. Voltage information is presented by vertical deflection of the trace and time information is presented by horizontal deflection. To obtain a useful display, it is necessary for the spot formed by the electron beam to be deflected horizontally at a known rate so that any horizontal distance on the screen represents a definite known period of time. The trace formed by the deflection of the spot across the screen is known as the horizontal sweep. Since the horizontal deflection of the spot bears a definite relationship to time and provides the means for making time measurements from the screen, the horizontal sweep is also known as the time base.

The Type 545A Oscilloscope features two independent time-base units: Time Base A and Time Base B. Either of the two time bases may be displayed on the oscilloscope screen at any time. Controls affecting Time Base A and Time Base B operation are in the correspondingly labeled blocks on the oscilloscope front panel. The HORIZONTAL DISPLAY switch determines which time base is used and the type of display to be presented. Time Base A is selected when the HORIZONTAL DISPLAY switch is in position A and Time Base B is selected when the switch is in position B.

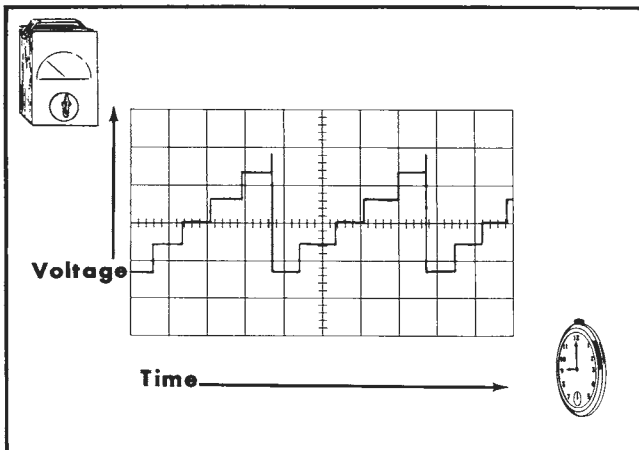

Fig. 2-4. The oscilloscope plots instantaneous voltage versus time, thereby serving both as a voltmeter and a timer.

The rate at which the spot is deflected across the screen is accurately controlled by the setting of the appropriate TIME/CM controls. The settings of the TIME/CM controls determine the sweep speed and the horizontal size of the displayed waveform. The controls are set to display the portion of the waveform you wish to observe.

Time Base A has 24 accurately calibrated sweep rates ranging from .1 microsecond to 5 seconds per centimeter. These calibrated sweep rates are obtained only when the VARIABLE TIME/CM control is in the fully clockwise position. The VARIABLE TIME/CM control permits you to vary the sweep rate continuously between .1 microsecond and approximately 12 seconds per centimeter. All sweep rates obtained with the VARIABLE TIME/CM control in any position but fully clockwise are uncalibrated. Uncalibrated sweep rates are indicated when the UNCALIBRATED lamp is lit.

Time Base B has sweep rates ranging from 2 microseconds to 1 second per centimeter in 18 steps. There is no VARIABLE TIME/CM control for Time Base B. The red LENGTH control adjusts the sweep length between approximately 4 and 10 centimeters.

Sweep Triggering

The oscilloscope display is formed by the repetitive sweep of the spot across the oscilloscope screen. If the sweeps are allowed to occur at random or at a rate unrelated to the rate of occurrence of the input waveform, the displayed waveform will be traced out at a different point on the screen each time the sweep runs. This will either cause the waveform to drift across the screen or to be indistinguishable.

In most cases it is desirable for a repetitive waveform to appear stationary on the oscilloscope screen so that the characteristics of the waveform can be examined in detail. As a necessary condition for this type of display, the start of the sweep must bear a definite, fixed-time relationship to the appearance of the input waveform. This means that the sweep must be synchronized with the input waveform. In the Type 545A Oscilloscope this is accomplished by starting (triggering) the sweep with the displayed waveform or with another waveform bearing a definite time relationship to the displayed waveform.

The following paragraphs outline the means for selecting the triggering source, triggering slope, and triggering level with specific information regarding the operation of the controls affecting triggering. Triggering controls for Time Base A and Time Base B are virtually identical so that the following information is applicable to both time-base units. Triggering of the sweep is adjusted by the respective STABILITY, TRIGGERING LEVEL, TRIGGERING MODE, and TRIGGER SLOPE controls.

Selecting the Triggering Source

In preparing the Type 545A Oscilloscope for triggered operation of the sweep, it is first necessary to select the triggering signal source which will provide the best display for the particular application. The sweep can be triggered by the displayed waveform, a line-frequency waveform,

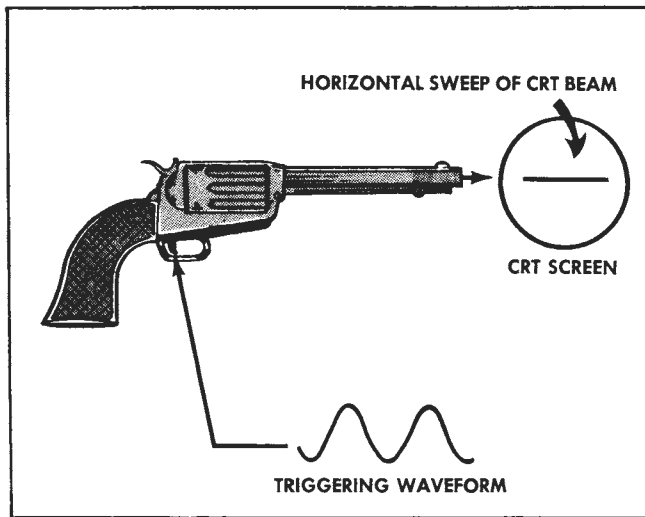

Fig. 2-5. In triggered-sweep operation the horizontal sweep of the crt beam is started by the trigger waveform.

or by an externally derived waveform. This selection is made by the setting of the TRIGGER SLOPE control. Each type of triggering has certain advantages for some applications.

Triggering from the displayed waveform is the method most commonly used. The displayed waveform is selected when the TRIGGER SLOPE control is in either the +INT. or -INT. position. Internal triggering is convenient since no external triggering connections are required. Satisfactory results are obtained in most applications.

When you are observing a waveform which is related to the line frequency, you may wish to trigger the sweep from a line-frequency waveform. This can be done by placing the TRIGGER SLOPE switch in either the +LINE or the -LINE position. This type of triggering is particularly useful in observing waveforms which bear a definite relationship to the line frequency. The shape and the amplitude of the triggering waveform remains constant to provide extremely stable triggering.

To trigger the sweep from some external waveform, connect the triggering waveform to the appropriate TRIGGER INPUT connector and place the TRIGGER SLOPE switch in either the +EXT. or -EXT. position. External triggering provides definite advantages over other methods of triggering in certain cases. With external triggering, the triggering signal usually remains constant in amplitude and shape. It is thereby possible to observe the shaping and amplification of a signal in an external circuit without resetting the oscilloscope triggering controls for each observation. Also, time and phase relationships between the waveforms at different points in the circuit can be seen. If, for example, the external triggering signal is derived from the waveform at the input to a circuit, the time relationship and phase of the waveforms at each point in the circuit are compared to the input signal by the display presented on the oscilloscope screen.

When you are using external triggering and a stable triggering signal, it is possible to observe and accurately measure jitter of the displayed waveform. This is not possible when the sweep is triggered internally.

Selecting the Triggering Slope

The horizontal sweep can be triggered on either the rising (+slope) or falling (-slope) portion of the triggering waveform as determined by the position of the TRIGGER SLOPE switch. When the switch is in one of the + positions, the sweep is triggered on the rising portion of the triggering waveform; when the TRIGGER SLOPE switch is in one of the - positions, the sweep is triggered on the falling portion of the waveform (see Figure 2-7).

In many applications the triggering slope is not important since triggering on either slope will provide a display which is suitable to the application. However, in many other cases, such as pulse measurements, the triggering slope is very important. If, while using a fast sweep, you may wish to observe the rise of a pulse, it will be necessary for you to trigger the sweep on the rising portion of the waveform by placing the TRIGGER SLOPE switch in one of the + positions. To observe the fall of a pulse at a fast sweep rate, it will be necessary to trigger the sweep on the falling portion of the waveform by placing the TRIGGER SLOPE switch in one of the - positions. In either case, selection of the wrong triggering slope will make it impossible for you to observe the portion of the waveform you wish to check.

Selecting the Triggering Mode

After selecting the triggering source and triggering slope, it is next necessary to select the triggering mode which will allow you to obtain the desired display. Time Base A has five triggering modes while Time Base B has three. Not available for Time Base B are the HF SYNC and AC LF REJECT triggering modes.

Each of the triggering modes is designed to provide stable triggering from a certain type of waveform. For most applications, however, several of the triggering modes will work equally well. For applications of this type, the triggering mode used is purely a matter of choice. The primary thing to consider in choosing the triggering mode is whether or not it allows you to obtain the display you want.

To determine the best mode of operation for a particular application, it is usually best to try each triggering mode in the application. The AUTOMATIC mode should be tried first since this triggering mode provides stable triggering in most applications without the necessity of setting the STABILITY or TRIGGERING LEVEL controls. If the AUTOMATIC mode does not provide the desired display, it will then be necessary for you to try one or more of the other triggering modes.

Automatic Triggering Mode

The AUTOMATIC mode is most frequently used because of its ease of operation. This mode is useful in obtaining stable triggering from waveforms with frequencies of from approximately 60 cycles to 2 megacycles. The principal advantage of this type of operation is that it is not necessary to adjust either the STABILITY or TRIGGERING LEVEL controls to obtain a stable display. This permits you to observe a large number of waveforms with different shapes

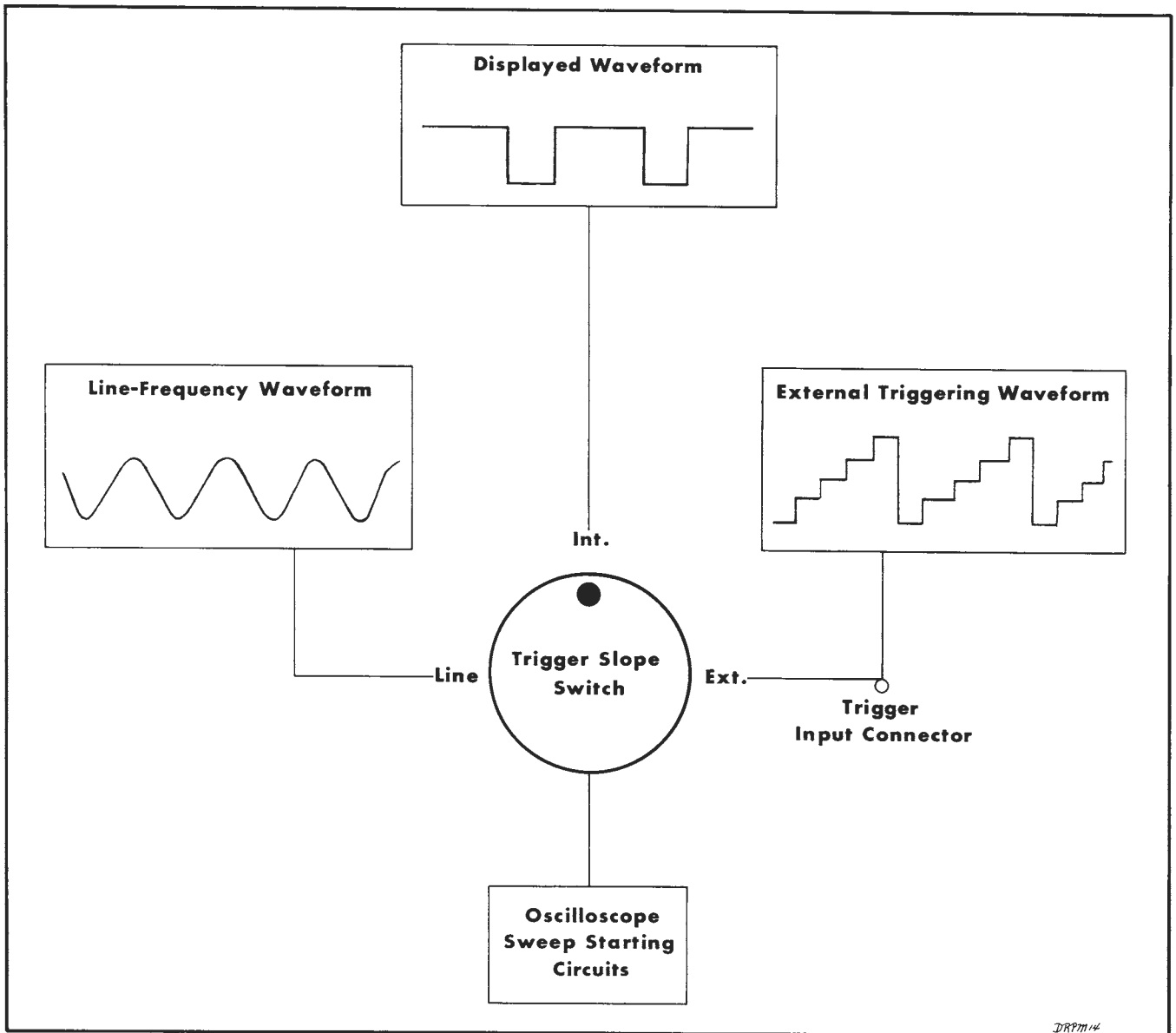

Fig. 2-6. The triggering signal is selected from three possible sources with the TRIGGER SLOPE control.

and amplitudes without adjusting any of the triggering controls. In the absence of a triggering signal, the sweep continues to run to provide a convenient reference trace on the oscilloscope screen.

The AUTOMATIC triggering mode is selected by placing the TRIGGERING MODE switch in the AUTO. position. The triggering source and slope is then selected and the input signal is applied to the oscilloscope. No other control adjustments are required. Since the TRIGGERING LEVEL control has no effect on the display when AUTOMATIC trig-

gering is used, it is impossible to select the point on the triggering waveform where the sweep is triggered. Each sweep is instead triggered at the average voltage point of the waveform.

DC Triggering Mode

The DC triggering mode is selected by placing the TRIGGERING MODE switch in the DC position. This mode permits excellent triggering on all types of waveforms in the

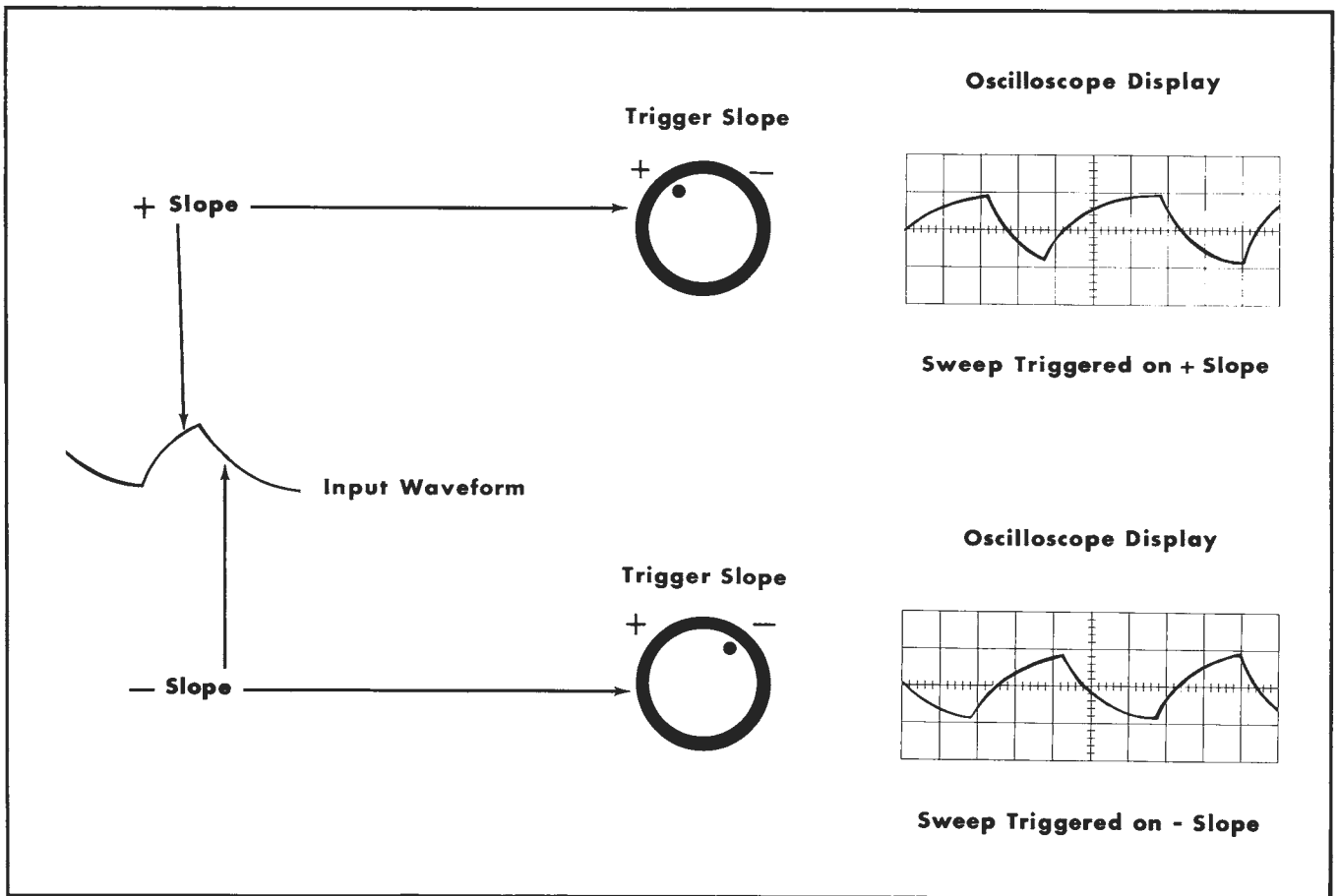

Fig. 2-7. Effects on the oscilloscope display produced by + and - settings if the TRIGGER SLOPE control.

frequency range from dc to approximately 5 mc. The DC mode also permits the selection of the point on the triggering waveform where the sweep is triggered through the use of the TRIGGERING LEVEL control.

To use the DC triggering mode you must set the STABILITY and TRIGGERING LEVEL controls after first selecting the triggering signal source and slope. The method used to set the STABILITY and TRIGGERING LEVEL controls is the same for the DC mode, AC mode, and AC Low Frequency Reject mode. The STABILITY control must be set properly before the TRIGGERING LEVEL control can be adjusted.

The STABILITY control has a PRESET position at the fully counterclockwise setting of the control. This position permits proper triggering in most applications without necessitating additional adjustment of the STABILITY control. If it becomes impossible or difficult for you to obtain proper triggering with the STABILITY control at PRESET, you must then adjust the control. This is done with the TRIGGERING LEVEL control fully counterclockwise. The STABILITY control is rotated clockwise from the PRESET position until a trace appears on the screen. The proper setting for the control is then obtained by rotating the knob slowly counterclockwise until the trace just disappears.

The TRIGGERING LEVEL control determines the point on the triggering waveform where triggering of the sweep occurs. This control is set to provide the display you want

while at the same time causing stable triggering. Rotating the control clockwise causes the sweep to trigger at more positive points on the waveform while rotating the control counterclockwise causes the sweep to trigger at more negative points. If the displayed waveform is vertically centered under the graticule, setting the TRIGGERING LEVEL control at 0 will cause the sweep to start at approximately the mid-voltage point of the waveform. In the DC mode, rotating the vertical position control will change the point on the triggering waveform where the sweep is started.

The + and - markings for the TRIGGERING LEVEL control should not be confused with similar markings for the TRIGGER SLOPE control. The markings on the TRIGGER SLOPE control indicate only whether triggering occurs on the rising or falling portion of the triggering waveform. The markings for the TRIGGERING LEVEL control indicate whether triggering occurs on the upper portion or lower portion of the waveform.

AC Triggering Mode

Selection of the AC triggering mode is made by placing the TRIGGERING MODE switch in the AC position. This mode provides useful triggering in the frequency range of approximately 15 cycles to 5 mc. These frequency limits vary slightly depending upon the shape and amplitude of

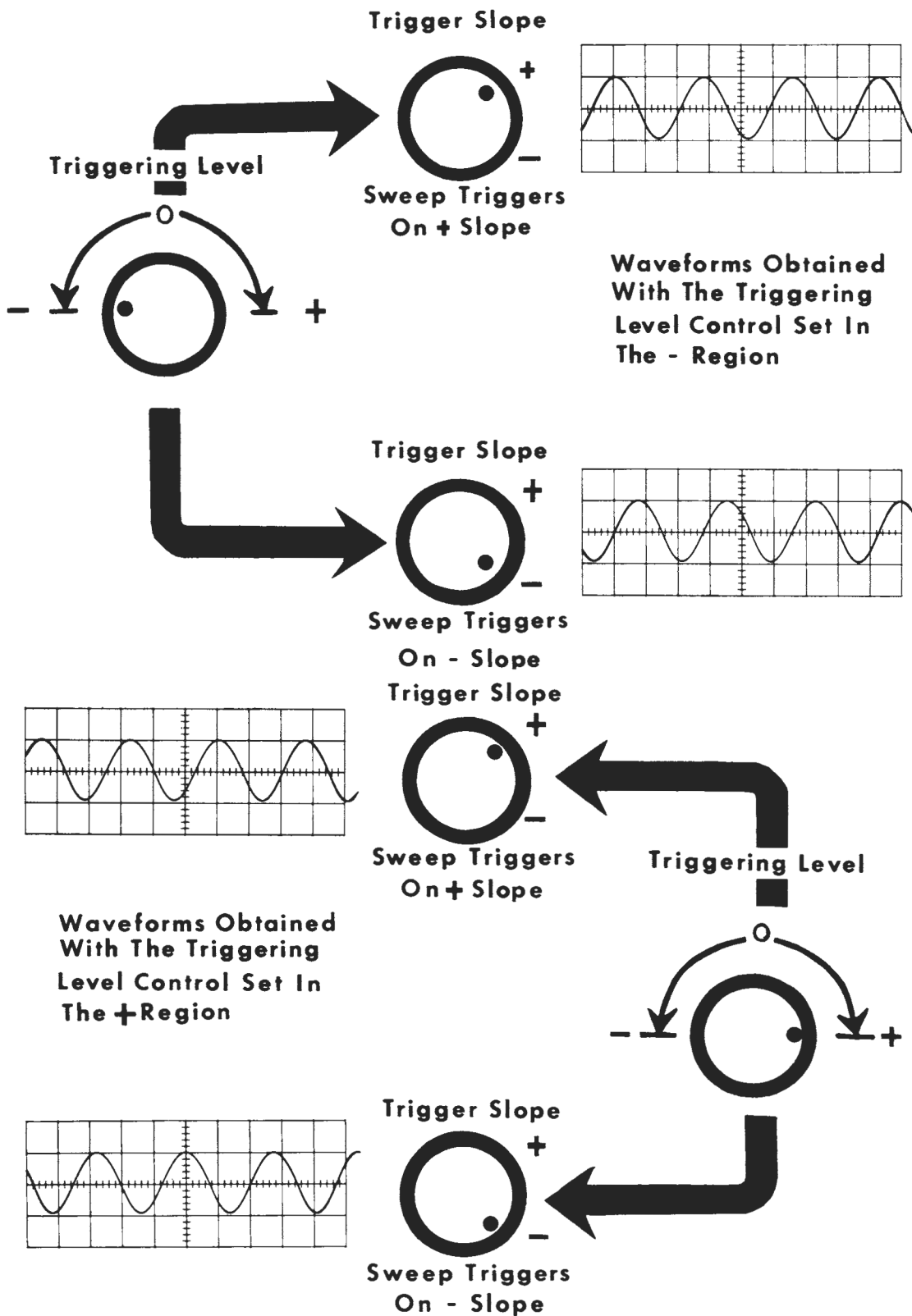

Fig. 2-8. Effects on the oscilloscope display produced by + and - settings of the TRIGGERING LEVEL control. When the TRIGGERING LEVEL control is set in the + region, the sweep is triggered on the upper portion of the input waveform; when it is set in the - region, the sweep is triggered on the lower portion of the input waveform. The TRIGGER SLOPE control determines whether the sweep is triggered on the rising portion or the falling portion of the input waveform.

the triggering waveform. In the AC mode, triggering is unaffected by the dc components of the triggering signal or by the vertical positioning of the trace. The triggering level can be selected to provide the desired display using the STABILITY and TRIGGERING LEVEL controls. These two controls are set as described for the DC triggering mode.

AC Low Frequency Reject Triggering Mode

The AC Low Frequency Reject triggering mode is used when the TRIGGERING MODE switch is in the AC LF REJECT position. This mode is similar to the AC mode except that low-frequency waveforms are rejected by the triggering circuit. This triggering mode works well with high-frequency waveforms, but it may be difficult to obtain stable triggering with frequencies below approximately 1000 cycles.

Occasionally you may be required to obtain stable triggering from a fairly high-frequency waveform that is mixed with a great deal of low-frequency noise or line-frequency pickup. In such cases the additional noise and pickup can make it very difficult to obtain a stable display. If this occurs, you can select the AC Low Frequency Reject triggering mode, thereby eliminating the effects of the low frequency noise and pickup. The low frequencies are blocked from the triggering circuit while the high-frequency triggering waveform is passed to produce the stable triggering that you require. In all other respects the AC Low Frequency Reject triggering mode is identical to the AC mode.

High Frequency Synchronization Mode

The High Frequency Synchronization Mode permits stable displays of waveforms with frequencies higher than approximately 5 mc. Stability of the display is adjusted with the STABILITY control. The TRIGGERING LEVEL control is not used. To use the High Frequency Synchronization Mode, place the TRIGGERING MODE switch in the HF SYNC position. Rotate the STABILITY control clockwise until a trace appears. Continue to adjust the STABILITY control until a stable display is obtained.

Although the synchronization signal source is selected with the TRIGGER SLOPE control, the slope cannot be selected. Also you cannot use the PRESET position of the STABILITY control in this mode.

Free-Running Sweep Operation

In the usual oscilloscope application, the sweep is triggered or synchronized by the input waveform. However, in some applications it may be more desirable to reverse the process and initiate the input waveform through use of a periodically recurrent waveform from the oscilloscope. In this type of application the sweep is caused to free-run and an output from either the +GATE or SAWTOOTH connectors is used to trigger or synchronize the input waveform (see Figure 2-9).

The sweep can be made to free run with any setting of the TRIGGERING mode switch by rotating the STABILITY

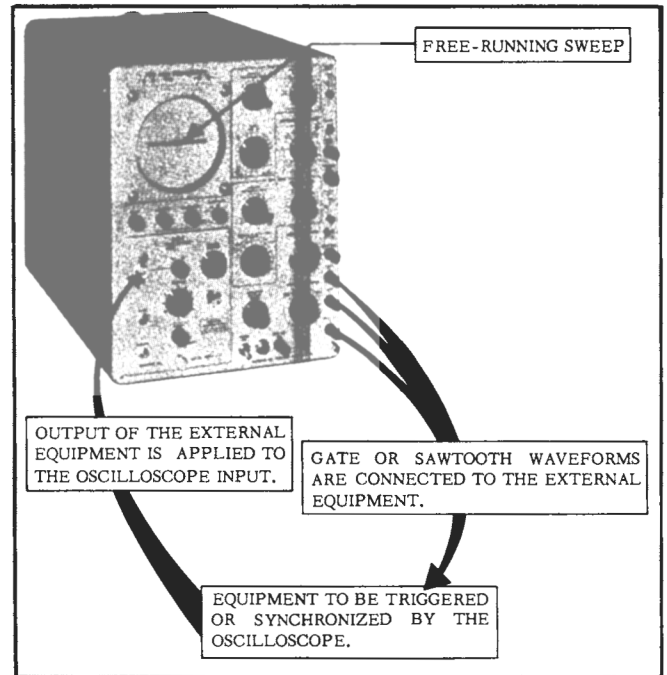

Fig. 2-9. Using the +Gate or Sawtooth output waveforms to synchronize or trigger external equipment.

control fully clockwise. In all positions of the TRIGGERING MODE switch except AUTO, the number of sweeps per second is determined by the setting of the TIME/CM controls. In the AUTO. position, the sweep repetition rate remains at approximately 50 sweeps per second regardless of the setting of the TIME/CM control.

In addition to providing the means for controlling an applied waveform, a free-running sweep also provides a convenient reference trace on the oscilloscope screen without requiring an input signal. This trace can then be used to position the sweep or to establish a voltage reference line.

Delayed Sweep

With the Type 545A Oscilloscope the start of the horizontal sweep can be delayed for a period of from 1 microsecond to 10 seconds after application of the triggering

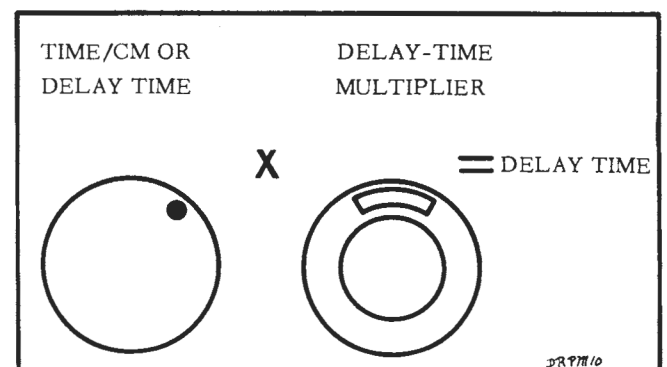

Fig. 2-10. Calculating delay time.

Operating Instructions — Type 545A

waveform. This is done through simultaneous use of Time Base A and Time Base B. In this application Time Base B is used to provide the accurate time delay while Time Base A presents a normal horizontal sweep at the end of the delay period. The duration of the sweep delay is controlled by the Time Base B TIME/CM OR DELAY TIME switch and the DELAY-TIME MULTIPLIER control.

The delayed sweep feature of the Type 545A Oscilloscope can be used in a number of special applications to increase the versatility of the instrument. Such applications include high magnification of a selected portion of an undelayed sweep, accurate time measurements, and accurate measurements of waveform jitter. Also, it is possible to pick off and display any desired line of a television scan or to check pulse-time modulation. In addition, the delayed sweep feature is readily adaptable to a great number of other applications.

The delayed sweep is selected when the HORIZONTAL DISPLAY switch is in the 'A' DEL'D BY 'B' position. The amount of delay occurring from the application of the triggering waveform until the sweep runs is indicated directly by the settings of the TIME/CM OR DELAY TIME switch and the DELAY TIME MULTIPLIER control. The settings

of the two controls are multiplied together to obtain the actual delay time. For example, if the TIME/CM OR DELAY TIME switch is set at 1 MILLISEC and the vernier dial of the DELAY TIME MULTIPLIER control indicates 6.75, the delay time is 6.75 milliseconds. When the Time Base A STABILITY control is in the fully clockwise position, the horizontal sweep starts immediately at the completion of the delay period at a rate determined by the settings of the Time Base A TIME/CM controls.

There are actually two modes of delayed sweep operation available in the Type 545A Oscilloscope (see Figure 2-11). In one mode the delayed sweep is started immediately after the completion of the delay time. This is the mode described previously and is obtained with the Time Base A STABILITY control fully clockwise. This mode permits you to select continuously variable delay times and is the mode of operation used to make accurate time and waveform jitter measurements as well as most other measurements.

The second delayed-sweep mode is different from the first in that the sweep does not start at the completion of the delay time until a triggering waveform is applied to Time Base A. The delay time in this mode is not continuously variable and is dependent not only on the settings of

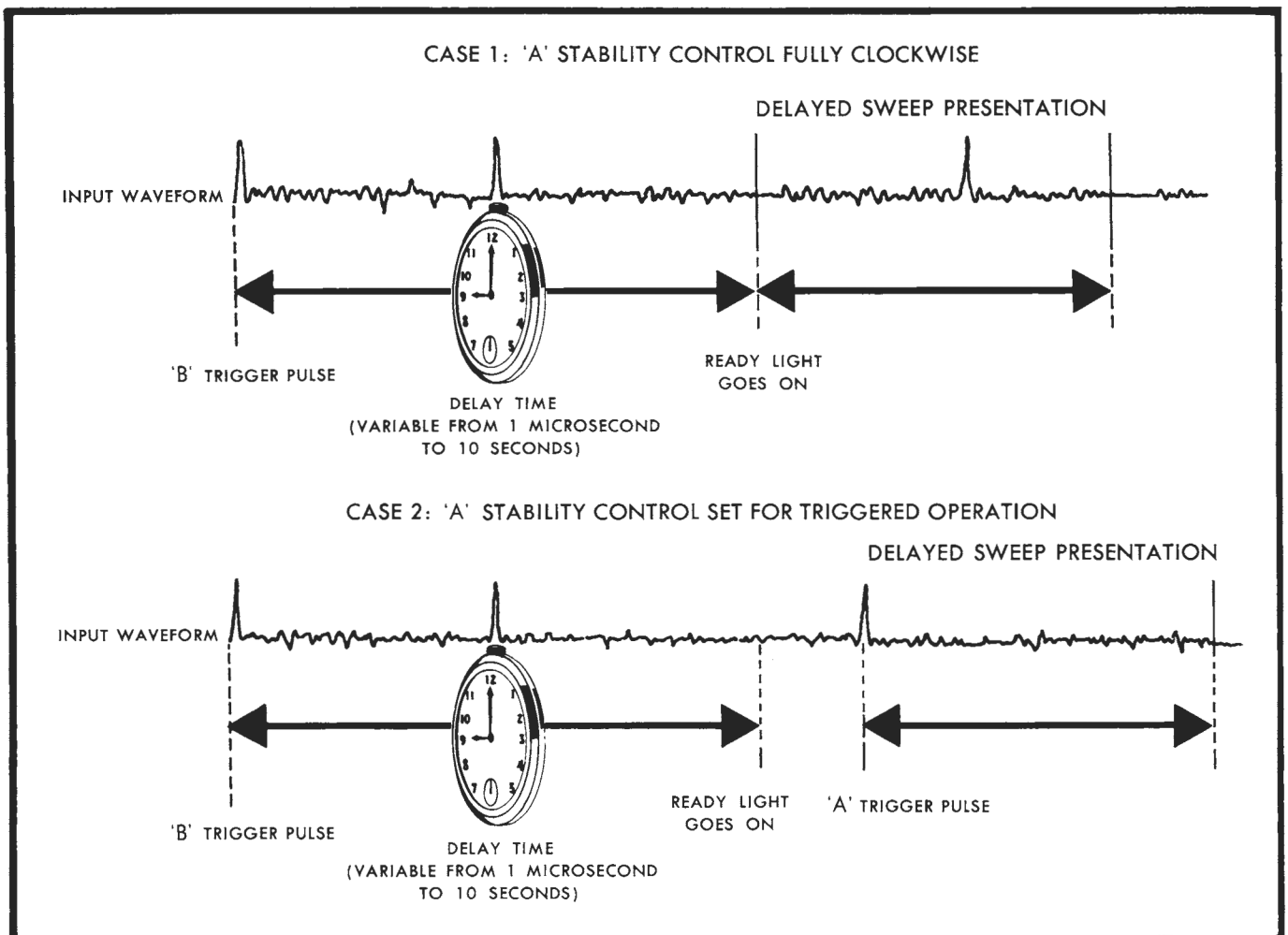

Fig. 2-11. Comparison of the two delayed-sweep modes. In each case the waveform shown represents the input to the oscilloscope. The waveform shown in the delayed-sweep presentation boxes represents the portion of the input waveform that is actually displayed on the oscilloscope screen. Note that in Case 2 an additional triggering pulse is required before the delayed sweep will occur.

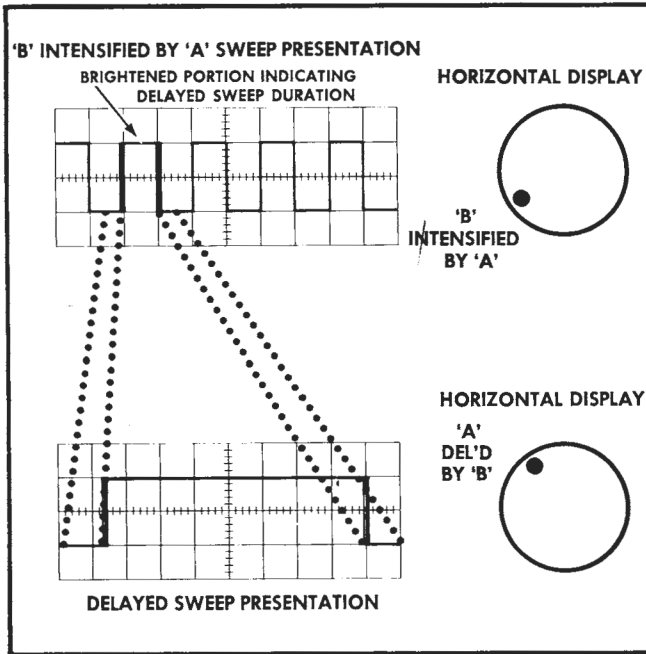

Fig. 2-12. Correlation of the 'B' INTENSIFIED BY 'A' and 'A' DEL'D BY 'B' positions of the HORIZONTAL DISPLAY switch.

the delay-time controls, but on the occurrence of the Time Base A triggering waveform as well. The primary purpose of this mode is to eliminate jitter from the displayed waveform. Since the sweep is triggered by the input waveform, jitter is eliminated from the display even though it is inherent in the input waveform.

The second delayed-sweep mode is also obtained with the HORIZONTAL DISPLAY switch in the 'A' DEL'D BY 'B' position. In this mode, however, the Time Base A triggering controls are set to provide normal triggering. The STABILITY control is not placed in the fully clockwise position.

When the HORIZONTAL DISPLAY switch is placed in the 'B' INTENSIFIED BY 'A' position, you can obtain a normal sweep presentation using Time Base B. If all other controls are set for delayed sweep operation and the Time Base A TIME/CM switch is set for a faster sweep rate than the Time Base B control, a portion of the displayed waveform will be brightened. The start of this brightened portion indicates the start of the delayed sweep and the length of the brightened portion indicates the delayed sweep duration. The start of the brightened portion can be positioned left or right with the DELAY-TIME MULTIPLIER control. The length of the brightened portion can be adjusted with the Time Base A TIME/CM control. Using these two controls, it is possible to include any portion of the displayed waveform in the brightened area.

To expand a portion of the display obtained with the HORIZONTAL DISPLAY switch in the 'B' INTENSIFIED BY 'A' position, adjust the DELAY-TIME MULTIPLIER and Time Base A TIME/CM controls to include the portion you wish to expand in the brightened area (see Figure 2-12). Then place the HORIZONTAL DISPLAY switch in the 'A' DEL'D BY 'B' position. This expands the brightened portion to the full width of the screen. The amount of magnification is the ratio of the Time Base B TIME/CM OR DELAY TIME control

setting to the Time Base A TIME/CM control setting. For example, if the Time Base B TIME/CM OR DELAY TIME switch is set at 1 MILLISEC and the Time Base A TIME/CM switch is set at 1 μ SEC, the brightened portion of the sweep is magnified horizontally 1,000 times. Using this method, practical sweep magnifications up to approximately 10,000 times are attainable.

At times when you are using the delayed sweep with high magnification, the intensity of the trace will be so low that it is difficult to see. In many of these cases the intensity cannot be improved significantly with the INTENSITY control. However, the intensity can often be increased by using the Time Base B SWEEP LENGTH control to increase the duty cycle. To set the SWEEP LENGTH control, place the HORIZONTAL DISPLAY switch in the 'B' INTENSIFIED BY 'A' position. Adjust the SWEEP LENGTH control until the sweep runs to a point just past the brightened portion of the trace. Then return the HORIZONTAL DISPLAY switch to the 'A' DEL'D BY 'B' position.

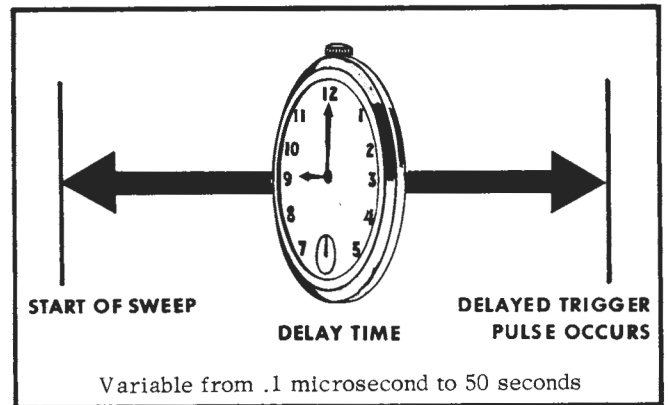

Fig. 2-13. Occurrence of the delayed triggering pulse. The delay time is adjusted with the DELAY-TIME MULTIPLIER control. The delayed triggering pulse occurs at the end of the delay time.

Delayed Trigger

A delayed triggering pulse can be obtained from the DEL'D TRIG. connector of the oscilloscope any time from .1 microsecond to 50 seconds after the start of a sweep. When the oscilloscope is set for delayed sweep operation, the delayed trigger occurs at the start of the delayed sweep. This delayed triggering pulse can be used to initiate some action after a known time interval, and when used with the delayed sweep, permits you to observe the resulting action.

In the B, 'B' INTENSIFIED BY 'A', 'A' DEL'D BY 'B', EXT. X1, and EXT. X10 positions of the HORIZONTAL DISPLAY switch, the delayed trigger is controlled by Time Base B. In the other two positions of the HORIZONTAL DISPLAY switch, the delayed trigger is controlled by Time Base A.

To obtain a delayed trigger you must first adjust the appropriate time-base unit for triggered operation or for free-running operation, depending upon the application. The delay is then set with the appropriate TIME/CM control and the DELAY-TIME MULTIPLIER. The lights above the DELAY-TIME MULTIPLIER control indicate which time-base unit is used to produce the delayed trigger with each setting of the HORIZONTAL DISPLAY switch.

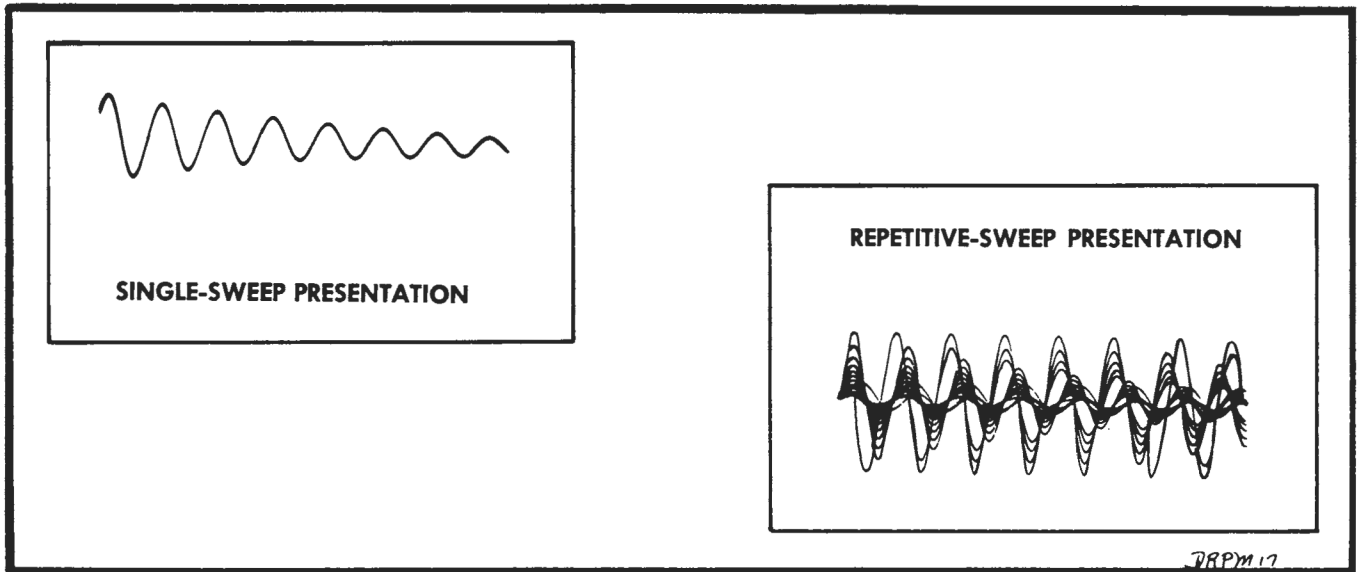

Fig. 2-14. Comparison of single sweep and repetitive sweep presentation of a damped sine wave. In the repetitive sweep presentation, it is difficult to determine what is being presented. However, in the single sweep presentation the damped sine wave can be clearly seen.

The usual oscilloscope display formed by a repetitive sweep is entirely satisfactory for most applications. However, in applications where the displayed waveform is not repetitive or varies in amplitude, shape, or time interval, a repetitive sweep produces a jumbled display. When observing a waveform of this type, it is usually advantageous to use a single-sweep presentation.

The Type 545A Oscilloscope permits you to obtain a single-sweep presentation and to eliminate all subsequent sweeps so that information is clearly recorded without the confusion resulting from multiple traces. The single-sweep feature is selected by placing the HORIZONTAL DISPLAY switch in the 'A' SINGLE SWEEP position. In this position, only Time Base A is used. The RESET button controls the start of the single sweep.

When the STABILITY control is set fully clockwise or the TRIGGERING MODE switch is in the AUTO. position, a single sweep runs immediately each time the RESET button is depressed. However, if Time Base A is set for triggered operation with the TRIGGERING MODE switch in other than AUTO. or HF SYNC positions, the single sweep does not occur when the RESET button is depressed unless a triggering signal is applied to Time Base A. Instead the READY lamp lights to indicate that the sweep is ready to be triggered. When a triggering signal occurs, the single sweep runs and the READY light goes out. Each time the RESET button is depressed the procedure is repeated.

External Horizontal Input

For special applications you can deflect the trace horizontally with some externally derived waveform. This allows you to use the oscilloscope to plot one function versus another.

To use an external horizontal input, connect the externally derived waveform to the HORIZ. INPUT connector and place

the HORIZONTAL DISPLAY switch in either EXT. position. The horizontal deflection factor is continuously variable from approximately .2 to approximately 15 volts per centimeter with the VARIABLE 10-1 control and the HORIZONTAL DISPLAY switch.

Sweep Magnifier

The sweep magnifier allows you to expand any two-centimeter portion of the displayed waveform to the full ten-centimeter width of the graticule. This is done by first using the HORIZONTAL POSITION control to move the

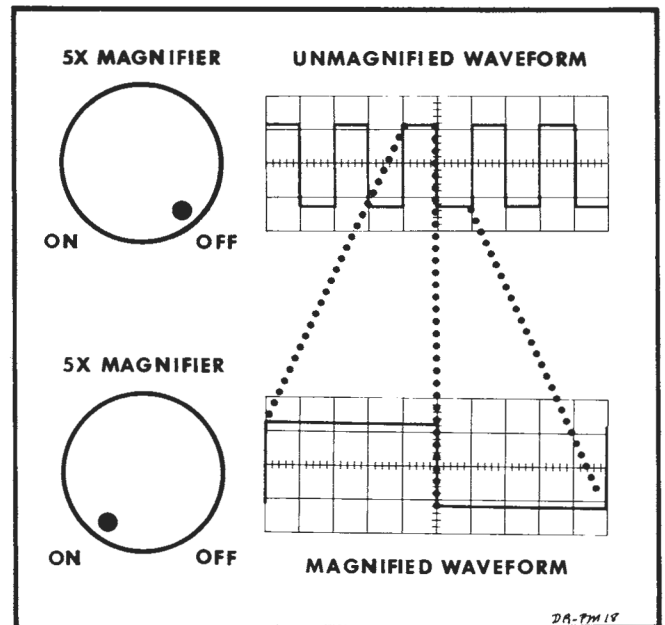

Fig. 2-15. Operation of the sweep magnifier.

portion of the display you wish to expand to the center of the graticule, then placing the 5X MAGNIFIER switch in the ON position. When the 5X MAGNIFIER switch is at ON, the 5X MAGNIFIER lamp lights to indicate the magnifier is on. Any portion of the original unmagnified display can then be observed by rotating the HORIZONTAL POSITION controls. The sweep magnifier can be used with either time base unit.

In magnified sweep operation, the sweep speed indicated by the position of the TIME/CM control is divided by 5 to obtain the actual time required for the spot to move one centimeter. For example, if the TIME/CM control is set at 5 MILLISEC, the actual time per centimeter is 5 milliseconds divided by 5, or 1 millisecond per centimeter. The actual time per centimeter must be used for all measurements of time.

Amplitude Calibrator

The amplitude calibrator provides a convenient source of square waves of known amplitude at a frequency of approximately 1 kc. The square waves are used primarily to adjust probes and to verify the calibration of the vertical-deflection system of the oscilloscope and plug-in unit.

Calibrator square-waves are adjustable from .2 millivolts, peak-to-peak, to 100 volts, peak-to-peak, in 18 steps. The amplitude is controlled by the setting of the AMPLITUDE CALIBRATOR switch and is accurate within 3% of the AMPLITUDE CALIBRATOR switch setting when the output is connected to a high impedance load.

Dual-Trace Displays

The Type CA Plug-In Unit allows you to obtain two separate traces on the face of the crt. This permits you to display two functions simultaneously. Detailed instructions for operating the Type CA Unit in conjunction with the Type 545A Oscilloscope are contained in the Instruction Manual for the Type CA Unit.

When you are using the Type CA Unit in the chopped mode to obtain a dual-trace presentation, switching transients will be displayed on the screen. You can eliminate these switching transients by placing the CRT CATHODE SELECTOR switch on the rear of the instrument in the DUAL-TRACE CHOPPED BLANKING position.

Intensity Modulation

The crt display of the Type 545A Oscilloscope can be intensity modulated by an external signal to display additional information. This is done by disconnecting the grounding bar from the EXTERNAL CRT CATHODE connector at the rear of the instrument and connecting the external signal to this terminal. The CRT CATHODE SELECTOR switch must be in the EXTERNAL CRT CATHODE position.

When you wish to make very accurate time measurements from the crt display, you can intensity modulate the beam with time markers and make your measurements directly from the time markers presented on the screen. A positive signal of approximately 25 volts is required to cut off the beam from normal intensity.

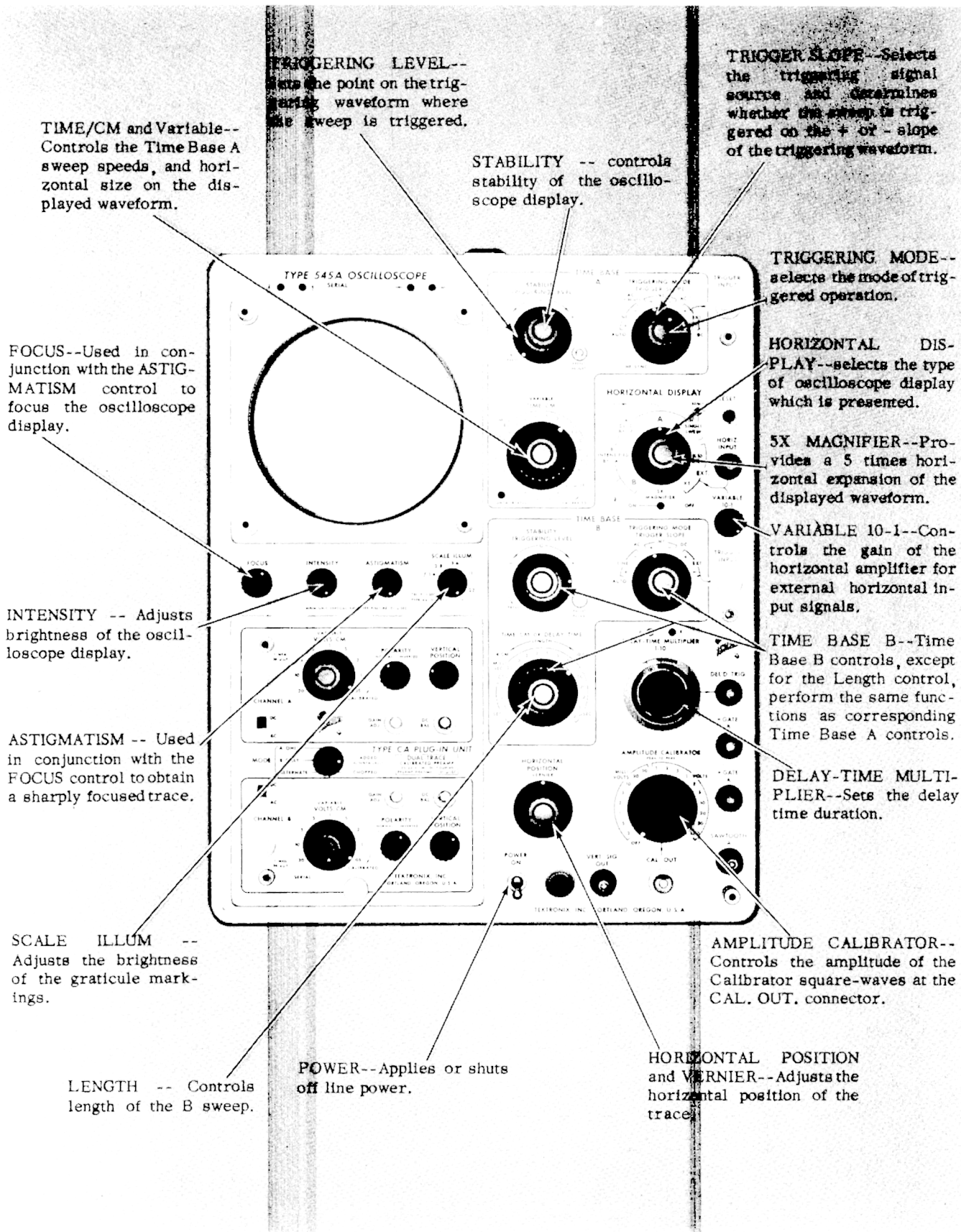
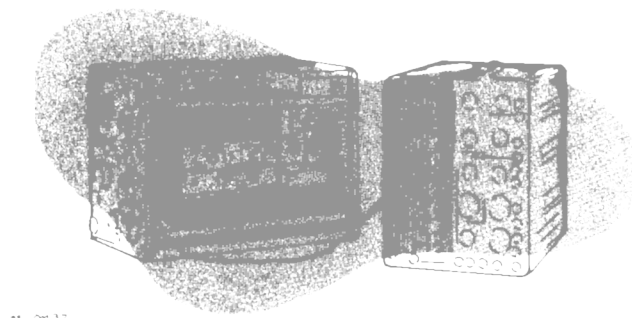

Fig. 2-16. Functions of the Type 545A Oscilloscope front panel controls.

APPLICATIONS



38-10132

Voltage Measurements

The Type 545A Oscilloscope can be used to measure the voltage of the input waveform by using the calibrated vertical-deflection factors of the instrument and associated plug-in unit. The method used for all voltage measurements is basically the same although the actual techniques vary somewhat depending on the type of voltage measurements required. Essentially there are two types of voltage measurements: ac-component voltage measurements and instantaneous voltage measurements with respect to some reference potential. Many waveforms contain both ac and dc voltage components. It is often necessary to measure one or both of these components.

When making voltage measurements, you should display the waveform over as large a vertical portion of the screen as possible for maximum accuracy. Also, it is important that you do not include the width of the trace in your measurements. You should consistently make all measurements from one side of the trace. If the bottom side of the trace is used for one reading, it should be used for all succeeding readings. The VARIABLE VOLTS/CM control must be in the CALIBRATED position.

AC Component Voltage Measurements

To measure the ac component of a waveform, the plug-in unit input selector switch should usually be set to one of the AC positions. In these positions only the ac components of the input waveform are displayed on the oscilloscope screen. However, when the ac component of the input waveform is of very low frequency it is necessary for you to make voltage measurements with the input selector switch in one of the DC positions to prevent errors.

To make a peak-to-peak voltage measurement on the ac component of a waveform, perform the following steps (see Figure 3-1):

1. With the aid of the graticule, measure the vertical distance in centimeters from the positive peak to the negative peak.
2. Multiply the vertical distance measured by the setting of the plug-in unit VOLTS/CM control to obtain the indicated voltage.
3. Multiply the indicated voltage by the attenuation factor of the probe used to obtain the actual peak-to-peak voltage.

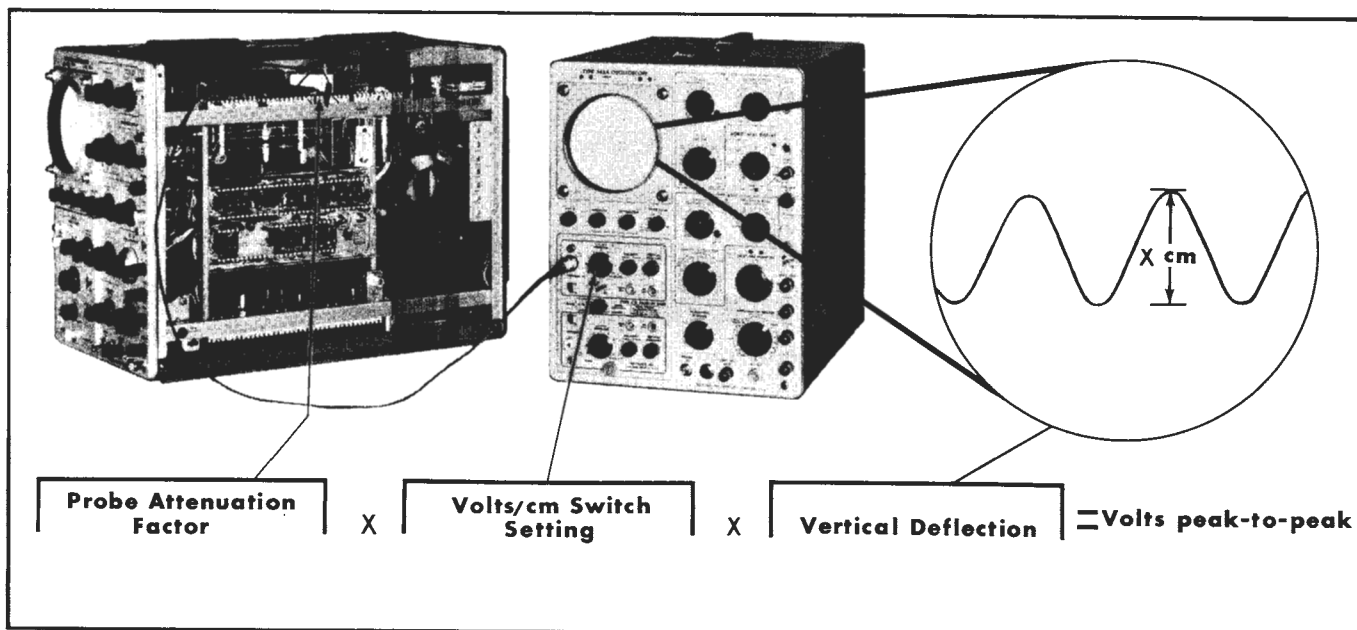

Fig. 3-1. Measuring the peak-to-peak ac component voltage of an applied waveform.

Applications — Type 545A

As an example of the method, assume that using a 10X probe and a deflection factor of 1 volt per centimeter, you measure a vertical distance between peaks of 4 centimeters. In this case then, 4 centimeters multiplied by 1 volt per centimeter gives you an indicated voltage of 4 volts peak-to-peak. The indicated voltage multiplied by the probe's attenuation factor of 10 then gives you the true peak-to-peak amplitude of 40 volts.

When sinusoidal waveforms are measured, the peak-to-peak voltage obtained can be converted to peak, rms, or average voltage through use of standard conversion factors.

Instantaneous Voltage Measurements

The method used to measure instantaneous voltages is virtually identical to the method described previously for the measurement of the ac components of a waveform. However for instantaneous voltage measurements the plug-in unit input selector switch must be placed in one of the DC positions. Also since instantaneous voltages are measured with respect to some potential (usually ground) a reference line must be established on the oscilloscope screen which corresponds to that potential. If, for example, voltage measurements are to be made with respect to +100 volts, the reference line would correspond to +100 volts. In the following procedure the method is given for establishing this reference line as ground since measurements with respect to ground are by far the most common type. The same general method may be used to measure voltage with respect to any other potential, however, so long as that potential is used to establish the reference line.

To obtain an instantaneous voltage measurement with respect to ground, perform the following steps (see Figure 3-2):

1. To establish the voltage reference line, touch the probe tip to an oscilloscope ground terminal (or if the reference line is to represent a voltage other than ground, to a source of that voltage) and adjust the oscilloscope controls to obtain a free-running sweep. Vertically position the trace to a convenient point on the oscilloscope screen. This point will depend on the polarity and amplitude of the input signal, but should always be chosen so that the trace lies along one of the major divisions of the graticule. The graticule divisions corresponding to the position of the trace is the voltage reference line and all voltage measurements must be made with respect to this line. (Do not adjust the vertical positioning control after the reference line has been established.)

2. Remove the probe tip from ground and connect it to the signal source. Adjust the triggering controls for a stable display.

3. Using the graticule, measure the vertical distance in centimeters from the desired point on the waveform to the voltage reference line.

4. Multiply the setting of the VOLTS/CM control by the distance measured to obtain the indicated voltage.

5. Multiply the indicated voltage by the attenuation factor of the probe you are using to obtain the actual voltage with respect to ground (or other reference voltage).

As an example of this method, assume that you are using a 10X probe and deflection factor of .2 volts per centimeter. After setting the voltage reference line at the second from the bottom division of the graticule, you measure a distance of 3 centimeters to the point you wish to check. In this case then, 3 centimeters multiplied by .2 volts per centimeter gives you an indicated .6 volts. Since the voltage point is above the voltage reference line the polarity is

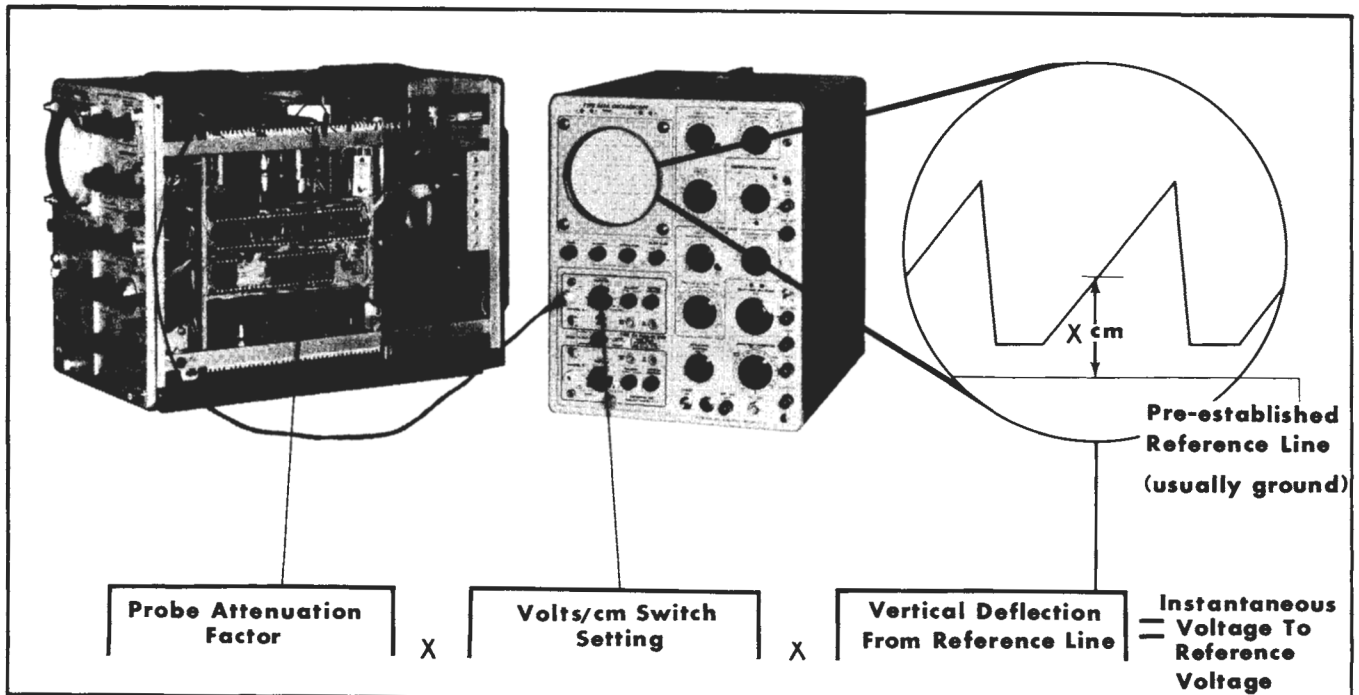

Fig. 3-2. Measuring the instantaneous voltage with respect to ground (or some other reference voltage).

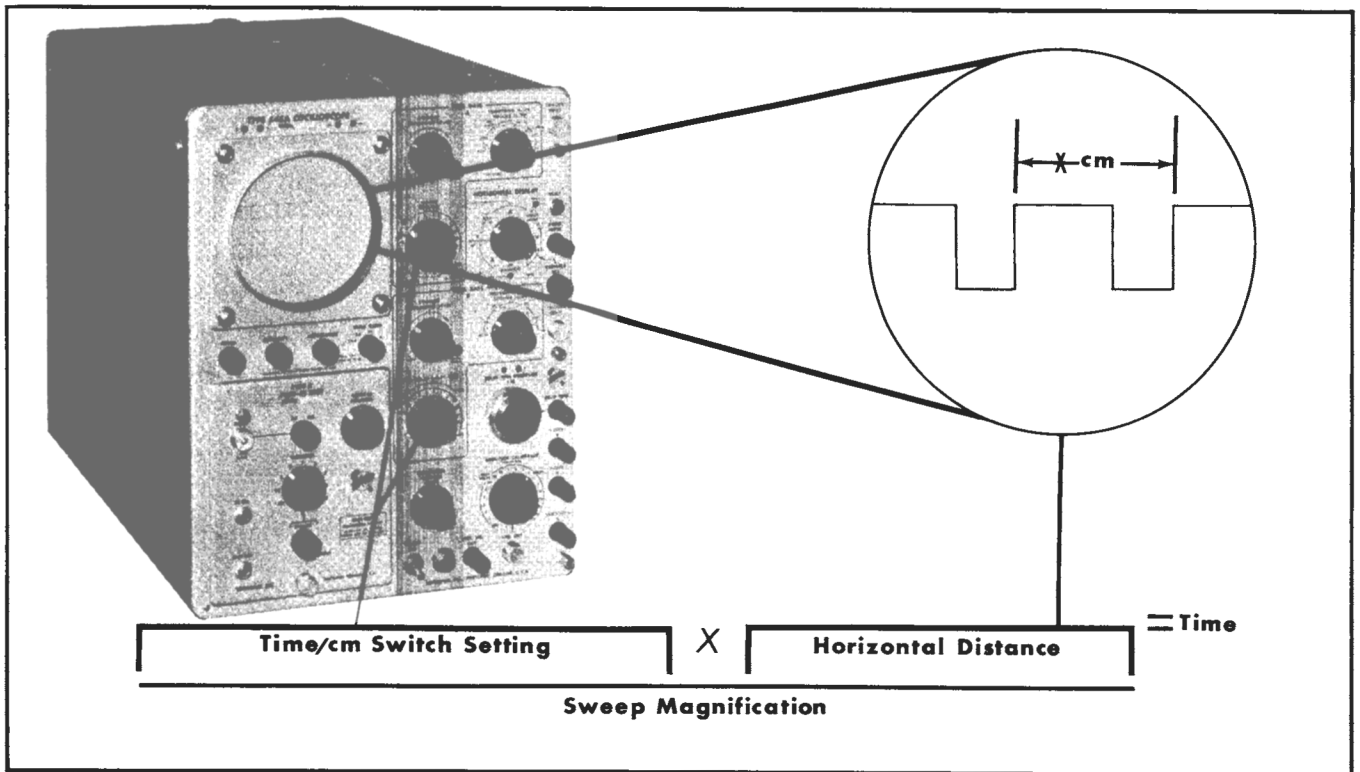

Fig. 3-3. Measuring time interval between events displayed on the oscilloscope screen.

indicated to be positive. The indicated voltage multiplied by the probe's attenuation factor of 10 then gives you the actual voltage of positive 6 volts.

Time Measurements

The calibrated sweeps of the Type 545A Oscilloscope cause any horizontal distance on the screen to represent a definite known interval of time. Using this feature you can accurately measure the time lapse between two events displayed on the oscilloscope screen. One method which produces sufficient accuracy for most applications is as follows (see Figure 3-3):

1. Using the graticule, measure the horizontal distance between the two displayed events whose time interval you wish to find.
2. Multiply the distance measured by the setting of the appropriate TIME/CM control to obtain the apparent time interval. (The VARIABLE TIME/CM control must be in the CALIBRATED position).
3. Divide the apparent time interval by 5 if the magnifier is on, and 1 if the magnifier is off, to obtain the actual time interval.

For example, assume that the TIME/CM switch setting is 1 MILLISEC, the MAGNIFIER is ON, and that you measure a horizontal distance of 5 centimeters between events. In this example then, 5 centimeters multiplied by 1 millisecond per centimeter gives you an apparent time interval of 5

milliseconds. The apparent time divided by 5 then gives you the actual time interval of 1 millisecond.

Another method for measuring time intervals involves the use of the delayed sweep feature of the Type 545A Oscilloscope. In this method the HORIZONTAL DISPLAY switch is placed in the 'B' INTENSIFIED BY 'A' position to brighten a portion of the trace. The brightened portion of the trace and the DELAY-TIME MULTIPLIER control are then used to make the time measurements. This method provides a very high degree of accuracy when care is taken in making the measurements. The method is summarized as follows:

1. Place the HORIZONTAL DISPLAY switch in the 'B' INTENSIFIED BY 'A' position and adjust the Time Base B triggering controls for a stable display of the input waveform. Adjust Time Base A for free-running operation.
2. Turn the intensity down until the brightened portion of the trace is easily distinguishable. Adjust the Time Base A TIME/CM controls to reduce the brightened area to a small spot or to cover as small a portion of the trace as possible.
3. Using the DELAY-TIME MULTIPLIER control, position the start of the brightened portion of the beginning of the interval you wish to measure. Record the setting of the DELAY-TIME MULTIPLIER control.
4. Using the DELAY-TIME MULTIPLIER control, position the start of the brightened portion of the trace to the end of the interval you wish to measure. Again record the setting of the DELAY-TIME MULTIPLIER control.

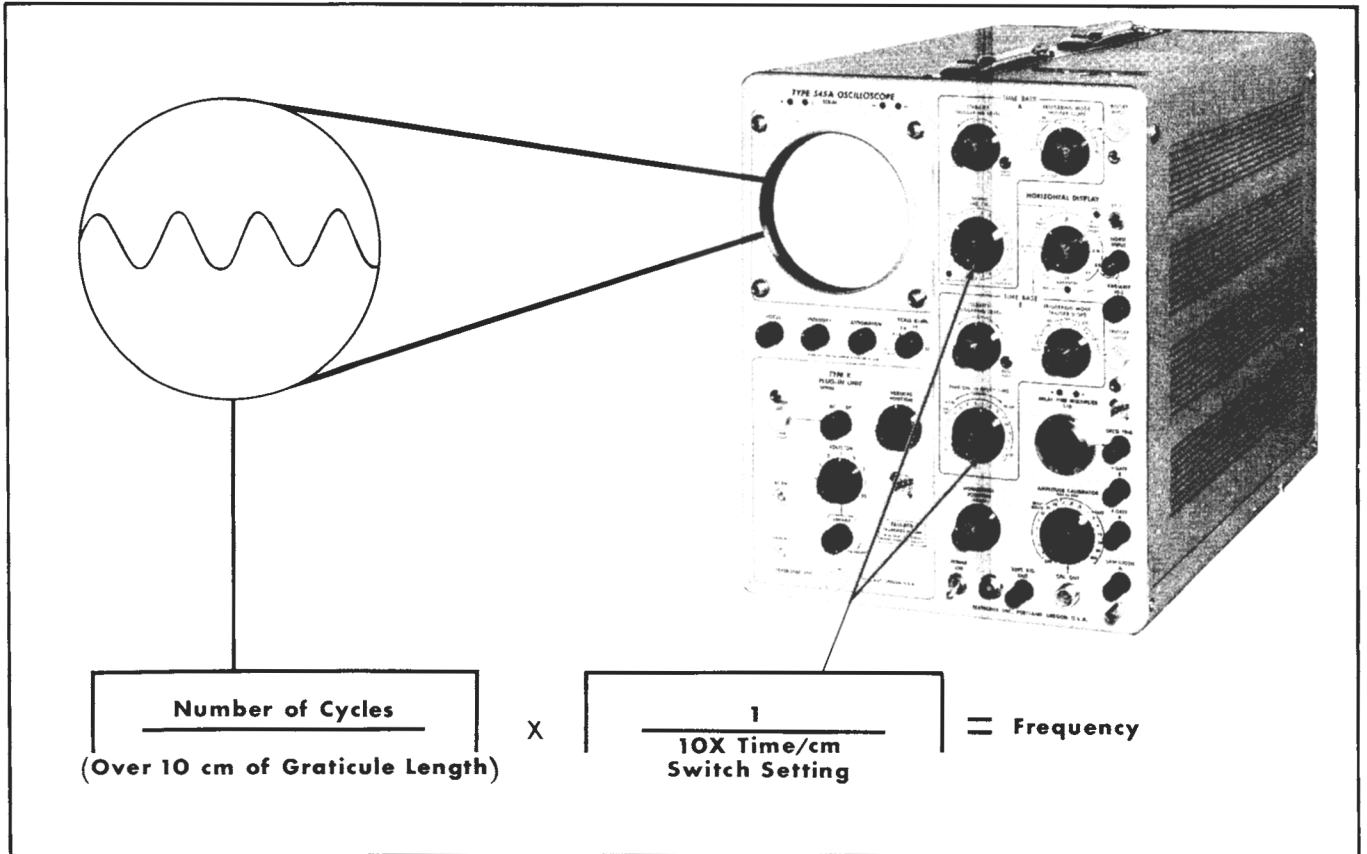

Fig. 3-4. Measuring the frequency of a repetitive input signal.

5. Subtract the first DELAY-TIME MULTIPLIER control setting from the second and multiply the result by the setting of the Time Base B TIME/CM control. The figure obtained is the time interval between the two events. The figure obtained is correct regardless of whether the magnifier is on or off.

Frequency Measurements

Using the methods described in the previous section, you can measure the period (time required for one cycle) of a recurrent waveform. The frequency of the waveform can then easily be calculated since frequency is the reciprocal of the period. For example, if the period of a recurrent waveform is accurately measured and found to be 0.2 microseconds, the frequency is the reciprocal of 0.2 microseconds, or 5 mc.

At any given oscilloscope sweep rate, the number of cycles of the input waveform that is displayed on 10 centimeters of the screen is dependent on the frequency of the input waveform. Frequencies can usually be measured faster by the following method than by the one given in the last paragraph.

If you divide the cycles per unit of length by the time required for the input waveform to sweep this unit of length, you get the frequency. The total number of cycles are found for 10 cm for greater accuracy. Since the TIME/CM switch gives time for 1 cm, multiply this setting by 10 to have the time required for 10 cm. (See Fig. 3-4).

To obtain the frequency of a repetitive input signal, perform the following steps:

1. Adjust the TIME/CM control to display several cycles of the input waveform. Insure that the VARIABLE TIME/CM control is in the CALIBRATED position.
2. Count the number of cycles of the waveform shown on the 10 centimeters of the graticule.
3. Divide this number by 10 times the TIME/CM switch setting. This gives you the frequency of the input waveform.

For example, assume that when you are using a sweep rate of 50 milliseconds per centimeter, you count 7.2 cycles in 10 centimeters. The frequency is 7.2 cycles divided by 50 milliseconds times 10, or 500 milliseconds. 500 milliseconds are 500 x .001 seconds, or .5 seconds. 7.2 cycles per 1/2 second gives you 14.4 cycles per second.

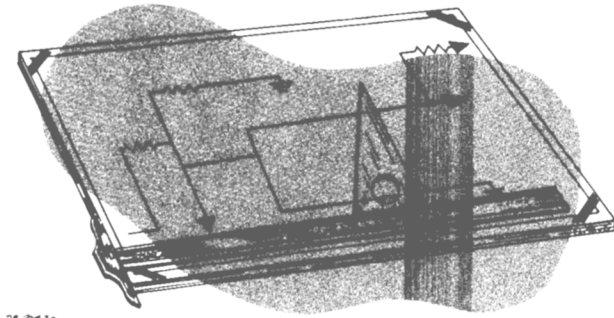
CIRCUIT
DESCRIPTION

VERTICAL DEFLECTION SYSTEM

General

The dc-coupled, push-pull, main Vertical Amplifier provides the necessary gain to drive the Delay Line and the vertical deflection plates of the crt. The main units of the Vertical Amplifier are the Input Amplifier stage V1014 and V1024, the cathode follower stages V1033 and V1043, and the 6-section Distributed Amplifier output stage. Other circuits of importance are the Trigger Pickoff Amplifier V1054 and V1064, the Trigger Pickoff C.F. V1223B, the Vert. Sig. Out. C.F. V1223A, and the Indicator Amplifiers and lamps, V1084A and B1083, and V1084B and B1087, respectively.

Input Circuit

The signal input from the plug-in unit is coupled through terminals 1 and 3 of the interconnecting plug to the grids of the Input Amplifier stage. GAIN ADJ., R1027 varies the cathode degeneration, and thus sets the gain of the stage to agree with the Preamplifier's front-panel calibration when the VARIABLE knob is in the CALIBRATED position.

The Input Amplifier is coupled to the Distributed Amplifier by the cathode followers V1033 and V1043. The cathode followers isolate the Distributed Amplifier from the Input Amplifier, and provide the necessary low-impedance drive for the Distributed Amplifier's grid line.

High-frequency compensation for the Input Amplifier is provided by the variable peaking coils L1014 and L1024. Variable inductors L1036 and L1046 provide additional peaking at the very high frequencies.

Output Stage

The output stage is a 6-section Distributed Amplifier. The tapped inductors in the transmission line, between each grid and between each plate, isolate each section from the capacitance of the adjacent sections.

The input signal for each tube is obtained from the grid line, which is driven by the cathode followers V1033 and V1043. The amplified signal at each plate, fed to the plate line, becomes an integral part of the wave traveling down the line toward the deflection plates.

The vertical signal is delayed 0.2 microsecond between the input to the grid line and the vertical deflection plates.

This delay insures that the very "front" of fast vertical signals can be observed. About 0.015 microsecond of the total delay time occurs in the Distributed Amplifier; the remaining 0.185 microsecond occurs in the Delay Line.

The tapped inductors between each section of the Distributed Amplifier provide about 0.003 microsecond of delay. By making the delay time in the grid and plate lines equal, the signal arriving at each plate, through the electron stream of the tube, will be synchronous with the signal moving down the plate line from the preceding sections.

DC Shift Compensation

DC shift in the amplifiers—a condition whereby the dc and very low-frequency transconductance is less than at mid-frequencies—is compensated for in two ways. R1090 and C1093B in plate line L1104, and R1095 and C1093D in plate line L1114, form a low-frequency boost network; the time constant of this network is such that the termination resistance of the line is increased in the range from very low frequencies to dc. A longer time constant, for extremely low-frequency and dc compensation is provided by R1092, R1094 and C1093A in one plate line, and by R1097, R1099 and C1093C in the other, which provide a small amount of positive feedback from the plate lines to the plate circuits of the Input Amplifier. A variable resistor R1091, the DC SHIFT ADJ. control, is connected between the two networks to adjust for the proper amount of compensation.

Beam-Position Indicators

The beam-position indicators B1083 and B1087 located on the front panel above the crt, indicate the relative vertical position of the trace with respect to the center of the graticule. When the beam is centered vertically, the potential across either neon is insufficient to light it. As the beam is positioned up or down the screen, however, the current through the Indicator Amplifiers, and hence the voltage across the neons will change. The voltage across one will increase, causing it to light, and the voltage across the other will decrease, causing it to remain extinguished. The neon that lights will indicate the direction in which the beam has been moved.

Trigger Pickoff

When internal triggering of the Time Base Generator is desired (black TRIGGER SLOPE knob on either the + or

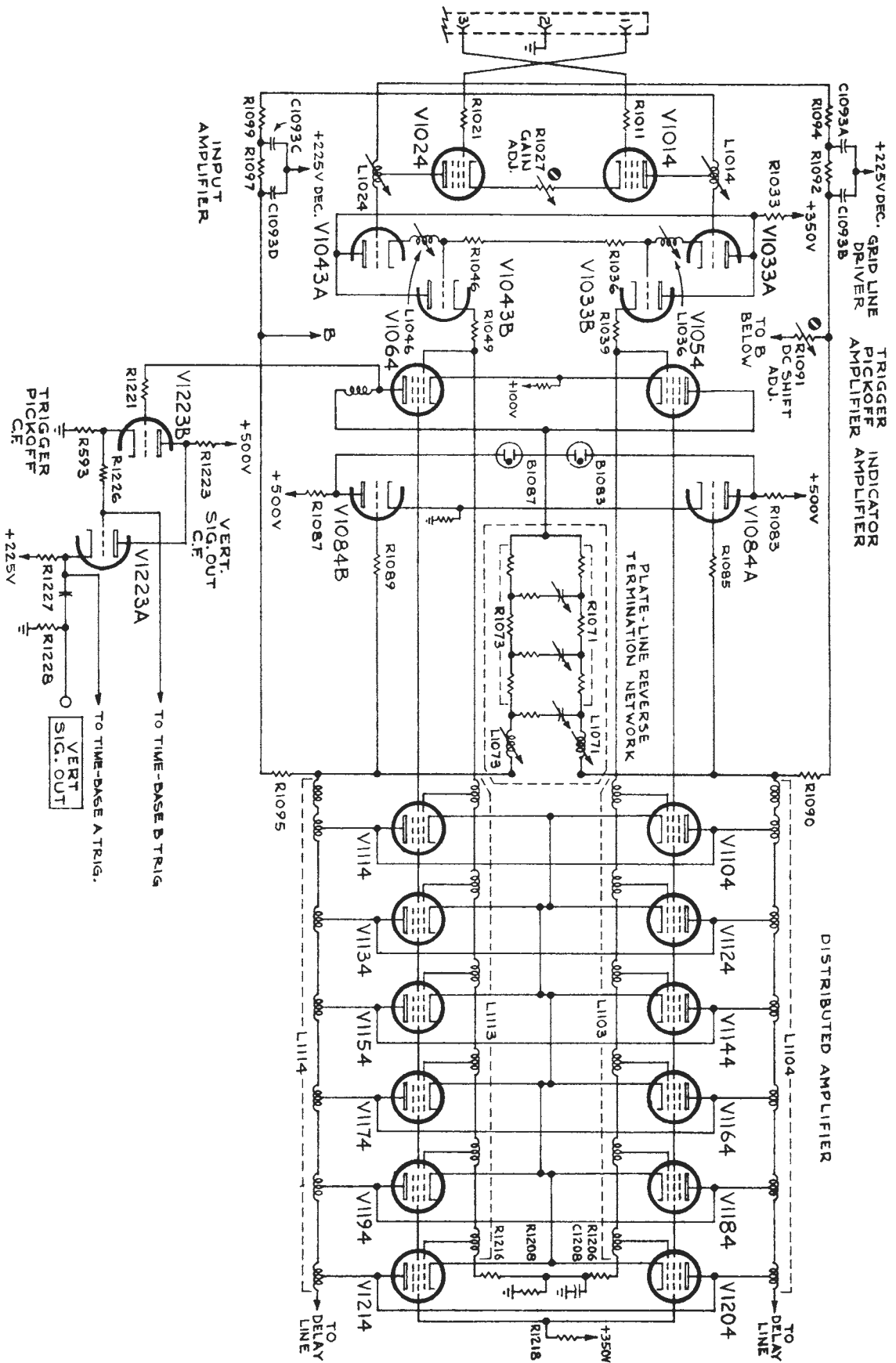

Fig. 4-1. Simplified Vertical Amplifier.

—INT. position), a "sample" of the vertical signal is used to develop the triggering pulse. This "sample" is obtained from the trigger pickoff circuit consisting of the Trigger Pickoff Amplifier V1054 and V1064, and Trigger Pickoff C.F. V1223B.

This "sample" of the vertical signal is also ac-coupled through V1223A and C1228, to a front-panel binding post labeled VERT. SIG. OUT.

Delay Line

The output signal from the Vertical Amplifier is coupled through the Balanced Delay Line to the vertical deflection plates of the crt. The function of the Delay Line is to retard the arrival of the waveform at the deflection plates until the crt has been unblanked and the horizontal sweep started. This delay, as mentioned previously, insures that the very "front" of fast vertical signals can be observed. The line is adjusted, by means of the variable capacitors connected across the line, for optimum transient response.

The entire Delay Line, which includes the plate line in the Distributed Amplifier, is reverse-terminated in its characteristic impedance. The Termination Network, shown on the Vertical Amplifier diagram, is designed to dissipate both the dc and signal energy in the line by presenting a constant resistance over the frequency range of the amplifier. The terminating resistors R1071 and R1073 are specially made, wirewound, noninductive, distributed resistors. The 600 ohms total resistance in each is "tapered", or distributed in steps. The largest segment of the terminating resistance appears nearest the line; the smallest segment appears at the opposite end. Each step of the resistance is then tuned, by means of the variable capacitors, so the network will present an optimum load to the line.

HORIZONTAL DEFLECTION SYSTEM

Time-Base Trigger

General

The Time-Base Trigger develops a pulse which will initiate a cycle of action in the Time Base Generator. To display signals below five megacycles, a TRIGGERING MODE switch allows the operator to select the type of triggered operation most suitable for the waveform to be displayed. A second switch, the TRIGGER SLOPE switch, allows the operator to select the "slope", either positive or negative, which will cause triggered operation of the sweep. To display signals above five megacycles, the Time Base Trigger is bypassed, and the signal is applied to the Sweep-Gating Multivibrator in the Time-Base Generator. (HIGH FREQUENCY SYNC. mode.) No choice of triggering slope is available in this mode.

Trigger-Input Amplifier

Triggering signals may be developed from several sources. The most common source of triggering signals utilizes the internal circuitry of the oscilloscope to sample the signal present in the vertical amplifier. Using an internal source

of triggering signal, either triggered operation in the various triggering modes, or synchronized operation, is available.

Triggered or synchronized operation of the time-base circuitry may also be effected from external sources. Operation in any of the available modes is possible with external signals.

In +Line or —Line positions of the TRIGGER SLOPE switch a voltage at the power line frequency is used to develop the triggering signal.

The Trigger-Input Amplifier is a polarity-inverting, cathode-coupled amplifier. It serves two basic functions in the Time-Base Trigger. First, it provides a source of negative-going signal to drive the following stage. Secondly, by means of the TRIGGERING LEVEL control, it enables the operator to select the signal at which triggered operation of the Time-Base will occur.

To trigger from a negative-going signal, the grid of the V24A section is connected to the input signal source. The grid of the V24B section is connected to a dc bias source, which is adjustable with the TRIGGERING LEVEL control. This bias voltage establishes the voltage present at the plate under no-signal conditions.

The voltage at the grid of V24A and the voltage at the plate of V24B are in phase with each other; that is, they both go through ac zero in the same direction at the same time. Thus, the V24A section acts as a cathode-follower, and the signal voltage developed across the cathode resistor becomes the input signal to the V24B section.

To trigger from a positive-going signal, the grid of the V24A section is connected to the TRIGGERING LEVEL control, and the grid of V24B is connected to the input signal. With this configuration, the voltage at the plate of the V24B section will be 180 degrees out of phase with the input-signal voltage.

In each of the cases outlined above, a negative-going signal is produced at the plate of the V24B section of the Trigger-Input Amplifier irrespective of the polarity of the input signal.

Also, the amplitude of the triggering signal necessary to cause operation of the following stage is determined by the setting of the TRIGGERING LEVEL control.

Trigger Multivibrator

The Trigger Multivibrator is a dc-coupled multivibrator. In the quiescent state, ready to receive a signal, the V45A section is conducting and the plate voltage is down. Since the plate is dc-coupled to the grid of the V45B section, that grid is held below cutoff. With the V45B section cut off its plate voltage is up and no output is developed.

The negative-going portion of the signal from the Trigger-Input Amplifier is required to drive the grid of the V45A section down. As the V45A section grid is driven negative the current flow through the tube is restricted, and the voltage at the plate starts to rise.

The rise in voltage at the plate of the V45A section carries the grid of the V45B section in the positive direction.

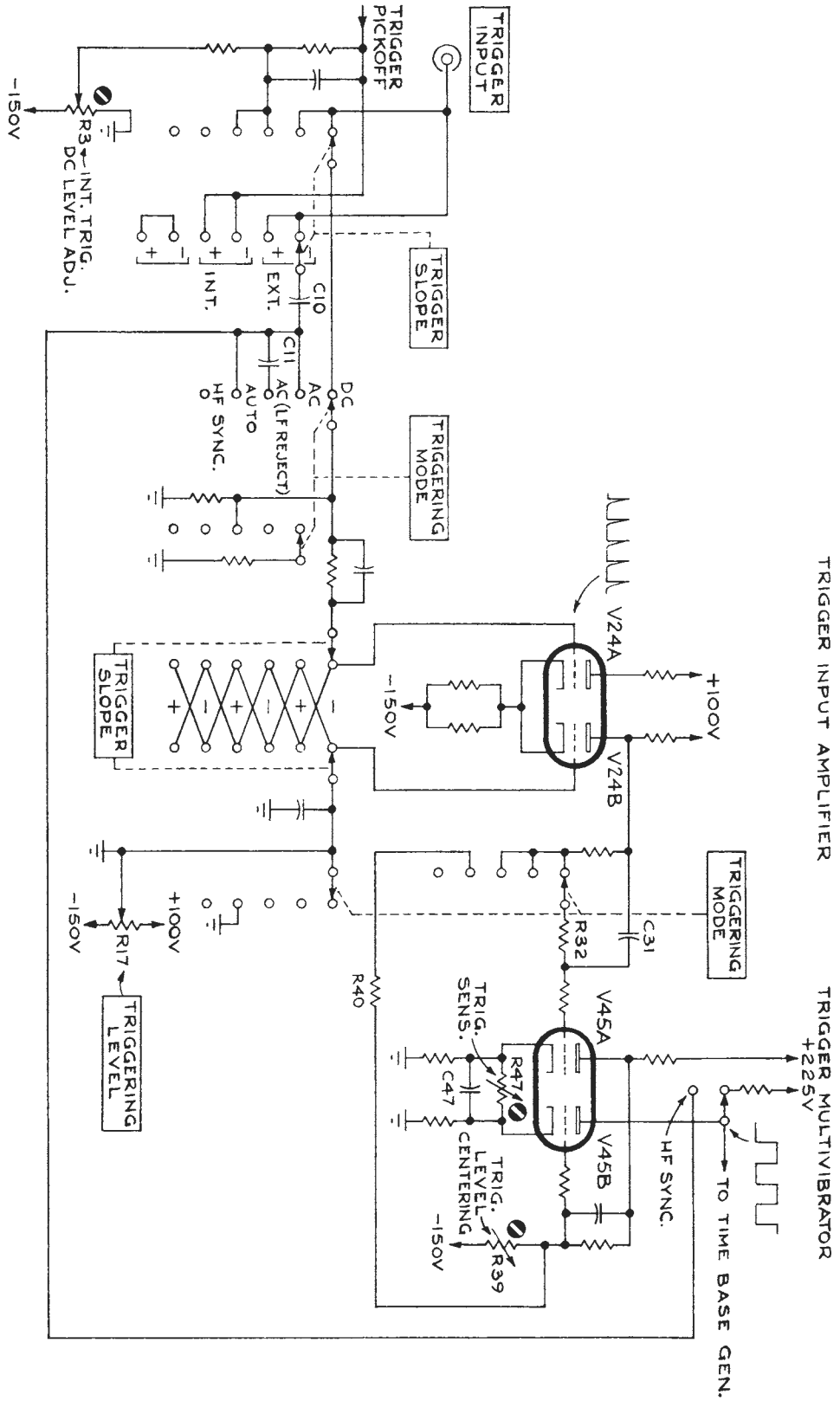

Fig. 4-2. Simplified Time-Base Trigger Circuit.

The cathodes of both sections are coupled together, and follow the action of the grids. With the V45B section grid going in a positive direction, and the cathode in a negative direction, the V45B section starts to conduct. As the V45B section starts to conduct the cathodes of both sections follow the action of the V45B section grid; hence the cathode voltage starts to rise.

As the V45A section grid goes down and its cathode goes up it stops conducting. As the V45B section conducts, its plate voltage drops, creating a negative step at the output. This transition occurs rapidly, regardless of how slowly the pentode grid falls.

When the signal applied to the grid of the V45A section goes in a positive direction the action described in the previous paragraphs reverses itself. That is, the V45A section will start to conduct once more, while the V45B section will be cut off.

In the AUTO. position of the TRIGGERING MODE switch the Trigger Multivibrator is converted from a bistable configuration to a recurrent configuration. This is accomplished by coupling the grid circuit of the V45A section to the grid circuit of the V45B section. In addition, the dc coupling between the grid of the V45B section of the Trigger Multivibrator and the plate of the V45A section of the Trigger-Input amplifier is replaced by ac coupling.

In the AUTO. triggering mode the Trigger Multivibrator will free run in the absence of a triggering signal. For example, assume that the grid of the V45A section is just being driven into cutoff. The voltage at the plate of the V45A section starts to rise, carrying with it the grid of the V45B section. As the voltage at the grid of the V45B section starts to rise, the V45B section starts to conduct.

The rising voltage at the grid of the V45B section is coupled to the grid of the V45A section through R40. The grid of V45A is prevented from rising immediately by the action of C31, which must be charged sufficiently to raise the voltage at the grid of the V45A section above cutoff.

As the V45A section starts to conduct, its plate voltage drops, which in turn lowers the voltage at the grid of the V45B section. The voltage at the grid of V45A starts dropping exponentially towards cutoff. When the V45A section reaches cutoff, the circuit has completed one cycle of an approximately 50-cycle repetition rate.

The Trigger Multivibrator produces a square-wave which is coupled to the Time-Base Generator. This square wave is differentiated in the Time-Base Generator to produce a sharp, negative-going pulse which is used to trigger the Time-Base Generator in the proper time sequence when triggered operation is desired. For synchronized operation of the Time-Base Generator, the TRIGGERING MODE switch is placed in the HF SYNC position. This couples the signal present at the input of the Time-Base Trigger directly into the Time-Base Generator, and the Time-Base Trigger circuitry is not used in the HF Sync mode.

Time-Base Generator

General

The Time-Base Generator consists of three main circuits: the Sweep-Gating Multivibrator, the Miller Runup Circuit,

and the Holdoff Circuit. The simplified schematic diagram of Fig. 4-3 shows the basic parts of each circuit, and the interconnections between circuits.

The Time-Base Trigger circuit furnishes the waveform which initiates a cycle of action in the Time-Base Generator. Square waves from the output of the Trigger Multivibrator are fed to the Time-Base Generator where they are differentiated and used as trigger pulses. In analyzing the action of the Time-Base Generator we will assume it to be in the quiescent state, just before the arrival of a suitable trigger pulse.

In the quiescent state of the Time-Base Generator V135A is conducting.

Square waves, generated by the Time-Base Trigger circuitry, are differentiated by the C131, R131 network.

If the STABILITY control, R110 is now advanced, the grid of V135A becomes more negative. As the grid of V135A becomes more negative, a point is reached at which a negative-going triggering pulse from the C131, R131 network will drive V135A into cutoff.

As V135A is driven to cutoff the plate voltage rises, carrying with it the grid of the cathode-follower stage, V135B. V135B, used as a cathode follower between the two halves of the multivibrator, isolates the positive-going plate of V135A from the capacitance of the loads requiring a positive-going pulse. This results in a faster rise of the positive-going pulse at the plate of V135A.

The cathode of V135B follows the action of the grid closely. This cathode is long-tailed through the resistors R141, R143. Since the grid of V145 has a certain shunt capacitance to ground, C141 is connected in parallel with R141 to compensate for this capacitance.

The voltage rise at the cathode of V135B drives the grid of V145 above cutoff. As V145 begins to conduct its plate voltage drops rapidly. Any spiking which may occur is attenuated by the C141, R141 network.

When V145 is conducting at the maximum determined by circuit parameters, the Sweep-Gating Multivibrator has reached its other stable state and the action of the Miller Runup circuit has been initiated.

Miller Run-up Circuit

The Miller Run-Up circuit is essentially a Class A amplifier employing negative feedback. The positive-going voltage at the plate of the Miller Tube is fed back to the grid through the Run-Up Cathode Follower, V173, in such a manner as to oppose the attempt of the grid to go negative. Because the gain of the Miller Tube is high, (approximately 200) it is possible to maintain an essentially linear rate of charge on the Timing Capacitor.

In the quiescent state of the Time-Base Generator the voltage at the plate of the Miller tube is determined by the voltage drop across a dc network formed by the neon lamp, B167, the Runup C.F., and the On-Off Diodes. The purpose of this dc network is to establish a voltage at the plate of the Miller Tube of such value that the tube will operate above the knee, and hence over the linear region of its characteristic curve.

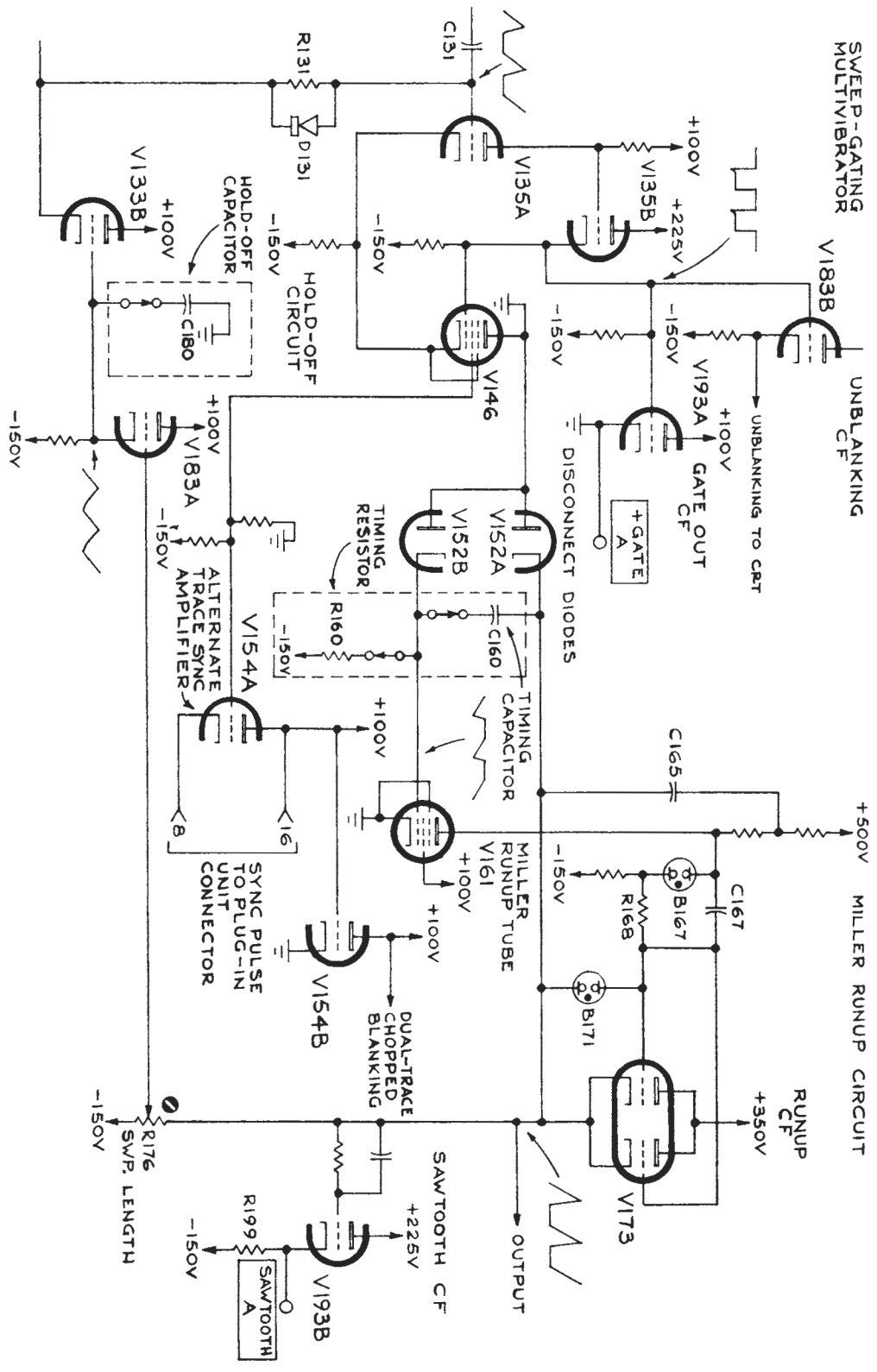

Fig. 4-3. Simplified Time-Base Generator.

The grid of the Miller Tube, V161, is returned to the -150-volt supply through the Timing Resistor, R160. In the quiescent state of the Time-Base Generator the grid of the Miller Tube is held slightly negative, but well above cutoff, by the flow of the current through the A section of the On-Off Diode. When the On-Off Diodes stop conducting the grid of the Miller Tube tends to become more negative.

As the grid of the Miller Tube starts negative the plate becomes more positive. This positive-going excursion of the plate carries the grids of V173, the Run-Up Cathode Follower, with it. The voltage at the grids of V173 is maintained at a constant difference with respect to the Miller Tube plate voltage by the voltage drop across the neon bulb, B167. C167 and R168 form a network connected around B167 to improve the risetime. A bootstrap capacitor, C165, is connected between a tap on the Miller Tube plate load and the cathode of V173. This bootstrap capacitor increases the charging rate of the stray capacitances in the Miller Tube plate circuit. Its action is most important in the generation of fast time-bases.

The cathode of V173 follows the action of the grids closely. This results in a linear rise in the voltage at the upper end of the Timing Capacitor, C160. Since the charge on the capacitor cannot change instantaneously this voltage is coupled to the grid of the Miller Tube in a direction to correct for the attempt of the Miller Tube grid to go negative.

Current to charge the Timing Capacitor is supplied through the Timing Resistor, R160. Since the voltage across the Timing Resistor is virtually constant a constant current source is thus provided for charging the Timing Capacitor.

The linear voltage rise at the cathode of V173 is used as the Time-Base sawtooth. This voltage rise continues until a positive step from the Sweep-Gating Multivibrator raises the plate voltage of the On-Off Diodes to the point at which they begin to conduct.

The positive-going voltage at the cathode of V173 is coupled back to the input of the Sweep-Gating Multivibrator and causes that circuit to revert to its other state. It is kept from acting on further trigger pulses by the action of the Holdoff Circuit.

The waveform coupled to the Time-Base Generator from the Time-Base Trigger circuit contains both positive- and negative-going pulses. To prevent a negative-going pulse from triggering the Sweep-Gating Multivibrator before the action of the Time-Base Generator is completed the grid of V135A must be held above cutoff.

Holdoff Circuit

The Holdoff Circuit keeps the grid of V135A above cutoff until the capacitances in the Time-Base Generator have had time to reach their quiescent state. The point at which the Holdoff Circuit will allow the Sweep-Gating Multivibrator to return to its quiescent state is determined by the adjustment of R176.

The sawtooth present at the cathode of the Run-up Cathode-Follower is coupled to the grid of V183A through R176. During calibration R176 is adjusted so that the time-base terminates after it has passed the right-hand limit of the

graticule. R176 adjusts the voltage at the grid of V183A and consequently at the cathode of V183A and on the capacitor C180.

The positive-going pulse from the cathode of V183A is coupled to the bus connecting the cathode of V183A and the grid of V133B. The action of the capacitor C180 retards the voltage at the grid of V133B. The value of C180 is chosen so that its capacitance will prevent the voltage at the grid of V133B from falling until all capacitances in the Time-Base Generator have returned to their quiescent level.

Output Waveforms

Various waveforms available during the cycle of action in the Time-Base Generator are made available through cathode followers for other functions. Shown in Fig. 4-3 are the unblanking pulse, the +Gate, and the Sawtooth from the Time-Base. The same signal used to provide the +Gate is used to provide the unblanking signal for the crt circuit.

Unblanking

In the quiescent state of the Time-Base Generator the crt beam is cut off. To allow the crt beam to be seen the potential at the control grid of the crt must be raised. The voltage rise appearing at the cathode of V135B in the Time-Base Generator is used to drive a cathode-follower in the crt circuit. This "unblanks" the beam during the time a sawtooth is generated, permitting the left-to-right motion on the beam to be seen.

The end of the unblanking pulse coincides with the end of the time-base, and the crt is "blanked" during the retrace portion of the sweep, and during quiescent periods of the Time-Base Generator.

Sweep "B" Circuits

In the Type 545A, the operator is offered a selection of two sweep circuits of very similar configuration and operating principles. The Time-Base Trigger B and Time-Base Generator B circuits are practically identical to those found in Time-Base A. There are, however, some noticeable differences between the Time Base A and Time Base B Timing switches, due to the difference in sweep rate selections between the two circuits.

Delay Pickoff Circuit

Delayed triggers can be applied to Sweep Generator A from the Delayed Trigger Amplifier, V114, through V133A which acts as a coupling C.F. to apply delayed triggers to the Sweep-Gating Multivibrator. Delayed Trigger Pulses are applied to the grid of V114 from the cathode of V428B.

These pulses are shaped and amplified in the Delay Pickoff Circuit, comprised of V414, V424, V445 and V428. The first stage of this circuit, V414 and V424 combine to form a difference amplifier which picks off a sample of the sawtooth output from Sweep Generator A or B and converts it into a positive pulse of step form. Before the pickoff

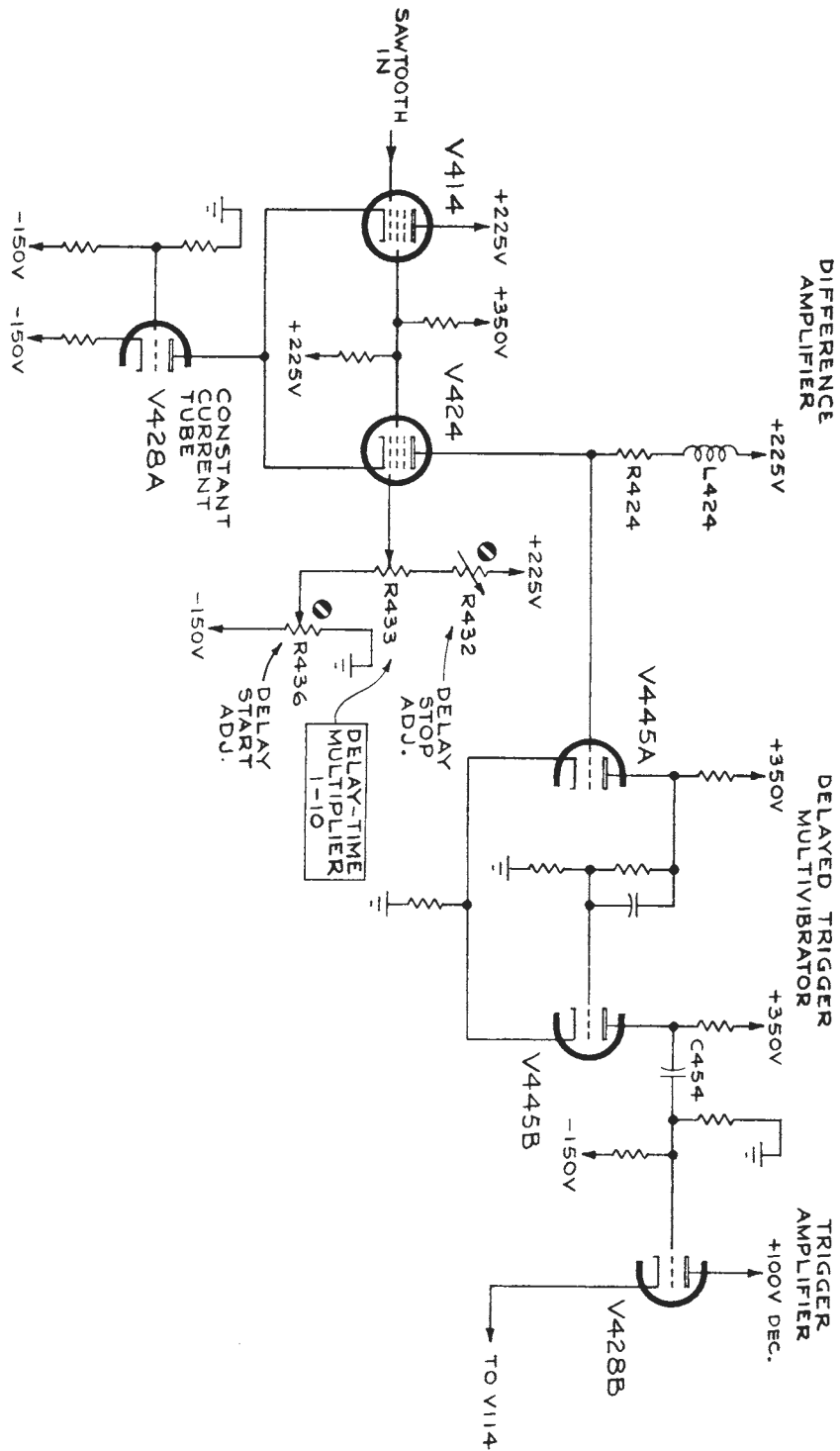

Fig. 4-4. Simplified Delay Pickoff Circuit.

time, V414 is cut off. Its cathode is tied to the cathode of V424 which is conducting, and therefore determining the common-cathode voltage.

The common-cathode voltage is adjustable by means of R433, a 10-turn helical resistor, labeled DELAY-TIME MULTIPLIER 1-10 on the front panel. V428A is a constant-current triode supplying cathode current to the difference amplifiers from the -150 volt supply. This arrangement permits the cathode of V424 to follow its grid over a wide range with very little variation of cathode voltage.

Plate current through R424 and L424 therefore also remains very nearly constant while V424 is conducting, no matter at what voltage the grid is set by the DELAY-TIME MULTIPLIER control, R433. This is important because the plate voltage of V424 is required to hold the grid voltage of the shaper stage, V445A, near the triggering point.

The positive-going delaying-sweep sawtooth raises the grid of non-conducting V414 toward its cathode voltage. When the grid rises past the cathode voltage set by the DELAY-TIME MULTIPLIER control, V414 conducts and V424 cuts off.

Delayed Trigger Multivibrator

When V424 cuts off because of conduction in V414, its plate rises, carrying the grid of trigger shaper V445A positive past its transition point. The trigger-shaper stage is regenerative so as to produce a fast transition, and the resulting positive step at the plate of V445B is differentiated through C454 and used to arm or to trigger the main-sweep circuits. The sharp differentiated pulse is transmitted to the succeeding circuits through cathode follower V428B.

Two internal screwdriver controls located on the "B" sweep gate at the right side of your oscilloscope and labeled, respectively, Delay Start Adj. and Delay Stop Adj., precisely adjust the upper and lower V424 grid voltage limits set by the DELAY-TIME MULTIPLIER so that centimeters of delay can be read within a fraction of one percent directly from the micrometer dial of the DELAY-TIME MULTIPLIER.

Single Sweep Operation

When the HORIZONTAL DISPLAY switch is in the A SINGLE SWEEP position, plate voltage is applied to V133A and this tube operates in conjunction with V125 as a bistable multivibrator.

In the first stable state that exists after the completion of a sweep, V125 is cut off and V133A is conducting. In this state the divider between the plate of V125 and the grid of V133A sets the cathode voltage of the Lockout Multivibrator and consequently the grid voltage of V135A. The Lockout Level Adj. R125 is adjusted to set the grid of V135A high enough so that the Sweep-Gating Multivibrator cannot be triggered; this "locks out" the sweep.

Depressing the RESET switch grounds C102 and R102. The resulting positive pulse at the grid of V125 forces the Lockout Multivibrator into its other stable state with V125 conducting and V133A cut off. With V133A cut off, its plate

voltage rises and ignites the READY light. With V125 conducting, the STABILITY control regains control over the grid level of V135A.

Depending on the adjustment of the STABILITY control, a sweep can now be produced in one of two ways. If the STABILITY control is turned full right (cw) the grid of V135A will be pulled down and cause the Sweep-Gating Multivibrator to switch to its other state and initiate a sweep. If the STABILITY control is adjusted for triggered operation, the sweep will be initiated by the first negative trigger pulse to arrive at the grid of V135A.

As the sweep begins, the rising sawtooth voltage pulls up the cathode of V133B by the holdoff action previously described. As the cathodes of the Lockout Multivibrator follow the cathode of V133B up, V125 cuts off and V133A conducts. As the cathodes continue to rise, following the rise in the sawtooth sweep voltage, V133A cuts off again. Both tubes are then held cutoff for the remainder of the sweep and the READY light stays on. When the grid of V135A rises to the point at which the Sweep-Gating Multivibrator is reverted, the sweep is terminated.

As the Hold-off Capacitor C180 discharges, the cathodes of the Lockout Multivibrator start to fall. The grid level of V133A is such that this tube comes out of cutoff first; thus, V133A conducts and V125 remains in cutoff. As V133A conducts its plate drops, extinguishing the READY light. A new sweep cannot be initiated until the RESET switch is depressed again.

Unblanking

The positive rectangular pulse at the cathode of V135B, in the Sweep-Gating Multivibrator circuit, is coupled through a cathode follower V183B (shown on the CRT circuit diagram, Fig. 4-10) to the grid supply for the crt. This pulse, whose start and duration are coincident with the rising portion of the sawtooth sweep waveform, pulls up the grid of the crt. This unblanks the crt during the trace portion of the sweep and permits the trace to be observed.

Output Waveforms

The positive pulse coupled to the crt circuit for unblanking is also coupled through a cathode follower V193A to a front-panel binding post labeled +GATE A. This positive gate waveform starts at ground and rises to +20 volts.

The sweep sawtooth voltage at the cathode of V173 is coupled through a cathode follower V193B to a front-panel binding post labeled SAWTOOTH A. This waveform, which starts at about ground, provides a 150-volt linear rise in voltage.

Dual Trace Sync and Blanking

Synchronizing pulses for dual-trace plug-in preamplifiers are supplied by V154A. When multi tube V145 cuts off a sharply differentiated positive pulse is developed at its screen. This pulse, coupled to the grid of V154A, produces a negative trigger at the plate of V154A. This trigger then

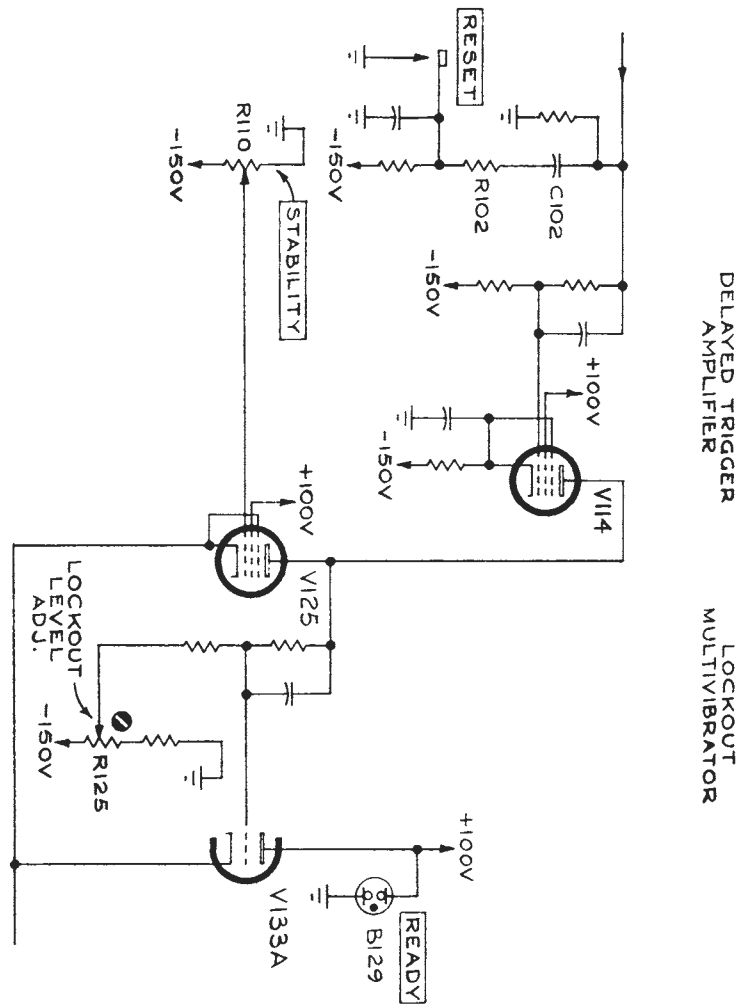

Fig. 4-5. Simplified Single-Sweep Circuit.

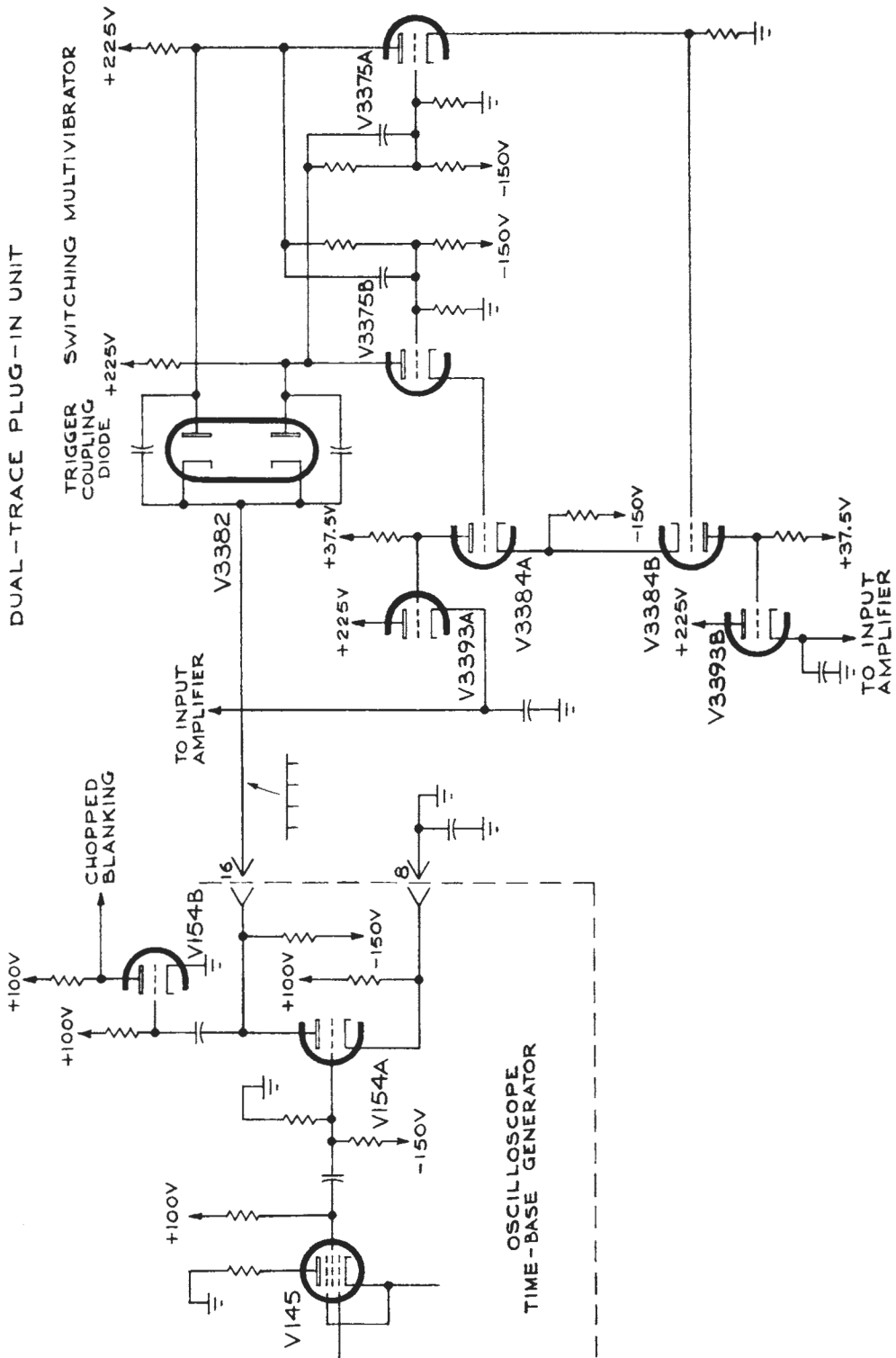

Fig. 4-6. Simplified Alternate-Trace Operation Circuitry.

Circuit Description — Type 545A

switches the multivibrator in the dual-trace unit employed for alternate sweeps.

When the dual-trace multi is connected for free-running operation to produce chopped sweeps, a negative pulse is coupled from the multi to the grid of V154B. The resultant positive pulse at the plate of V154B is coupled to the cathode of the crt to blank out the beam during switching. Refer to the manual for the dual-trace unit for a detailed description of the switching operation.

Alternate-Trace Operation

Alternate-trace operation is available with Tektronix convertible oscilloscopes by employing the 53C, 53/54C or Type CA plug-in preamplifiers. Additional circuitry in the Time-Base Generator circuit provides a pulse to "flip" a bistable multivibrator in the plug-in. This multivibrator provides a change in dc level at the inputs of the amplifiers in the plug-in. This change in dc level is used as a positioning voltage which separates the two traces a distance selected by the operator.

The Time-Base Generator circuitry necessary for alternate-trace operation utilizes an amplifier which amplifies the signal present at the grid of V154A. The signal at the plate of the amplifier, V154A, is connected to pin 16 of the interconnecting socket, while the signal at the cathode is connected to pin 8 of the interconnecting socket. Fig. 4-3 shows the Time-Base Generator circuitry involved. Fig. 4-6 shows the plug-in circuitry which affects the positioning.

Negative-going pulses, generated at the end of each time-base by the Sweep-Gating Multivibrator in the Time-Base Generator, are amplified by the amplifier, V154A. The pulses are coupled through the interconnecting socket to the Trigger Coupling Diode in the plug-in. Each trigger causes the multivibrator to "flip" from one stable state to another at a rate determined by the repetition rate of the Time-Base Generator.

The square-waves present at the cathodes of the multivibrator tubes are used to drive the amplifiers, V3384A and V3384B. The signals from these amplifiers are used to drive V3393B and V3393A; cathode followers which isolate the multivibrator circuitry from the signal amplifiers. The output of the cathode followers raises or lowers the plate voltage of the Input Amplifiers as the multivibrator passes from one stable state to the other.

In later Tektronix instruments an additional stage has been added in the Time-Base Generator to provide blanking when the plug-in is operated in the CHOPPED MODE. This is shown as V154B in Fig. 4-3. In the CHOPPED MODE of operation the multivibrator in the plug-in free runs at a rate determined by circuit constants. Transients generated during free-running operation are blanked from appearing on the crt screen by the action of V154B.

Horizontal Amplifier

The Horizontal Amplifier converts the single-ended sawtooth output of the Time-Base Generator into push-pull signal suitable for driving the horizontal plates of the crt.

The gain of the amplifier may be varied by a factor of five by means of the 5X MAGNIFIER switch. In addition, controls are provided for horizontal positioning and adjustment of the horizontal linearity.

The sawtooth waveform from the Time-Base Generator is coupled to the Input Cathode Follower through the R330, C330 network. This network attenuates the input signal and provides a means of compensating the input circuitry for optimum frequency response. During calibration C330 is adjusted for best response to a square wave.

The HORIZONTAL POSITION and VERNIER controls adjust the dc level at the grid of V343A. This change in dc level changes the dc level on the signal path through the amplifier, thus changing the dc voltage applied to the crt horizontal deflection plates and affecting horizontal positioning.

Coupling between the Input CF and the Driver CF is made by the 5X MAGNIFIER switch. When this switch is in the OFF position the signal from the Input CF must pass through the network formed by C348 in parallel with the series combination R348, and R349. R348, a variable resistor, allows the operator to adjust the length of the time base by varying the attenuation applied to the signal. C348, a variable capacitor, is adjusted to provide optimum linearity of the time base on the fastest time bases.

This network attenuates the signal by a factor of five. To provide magnification of the time base, the network is removed when the 5X MAGNIFIER switch is turned to the ON position.

The gain of the Horizontal Amplifier is controlled by a negative-feedback circuit. The signal appearing at the left-hand deflection plate is fed back to the input of the Driver CF. R358 is an adjustable resistor which allows the operator to vary the dc voltage applied to the feedback loop.

By changing the dc voltage at this point the operator can adjust the position of the unmagnified sweep so that it will correspond with the position of the magnified sweep.

The output waveform from the Horizontal Amplifier is taken from V364A and V384A. The cathodes of these tubes are connected through a network which includes the Mag. Gain control. This control enables the operator to adjust the gain of the Horizontal Amplifier so that the ratio between the magnified and unmagnified sweeps is correct. C375, in parallel with the Mag. Gain control, has considerable effect on the linearity at the beginning of the time base, and is adjusted while displaying a signal with a high repetition rate.

Part of the signal appearing at the plates of the output amplifiers is used to drive the Output CFs. Note that the cathode of V364B is connected to the plate of V398, a pentode. The function of the Output CFs is to drive the capacitance of the horizontal deflection plates and the associated wiring. To assure a sufficient flow of current at fast time bases, the pentode, V398 is used to supply current to the Output CF which drives the negative-going, or left-hand deflection plate. A pentode is chosen as a current booster, since its plate characteristic provides a flat-topped pulse of current. The pulse to drive the grid of the pentode is derived from the waveform at the right-hand deflection plate. This waveform is differentiated by the C390, R390 network before being applied to the grid. Its amplitude is

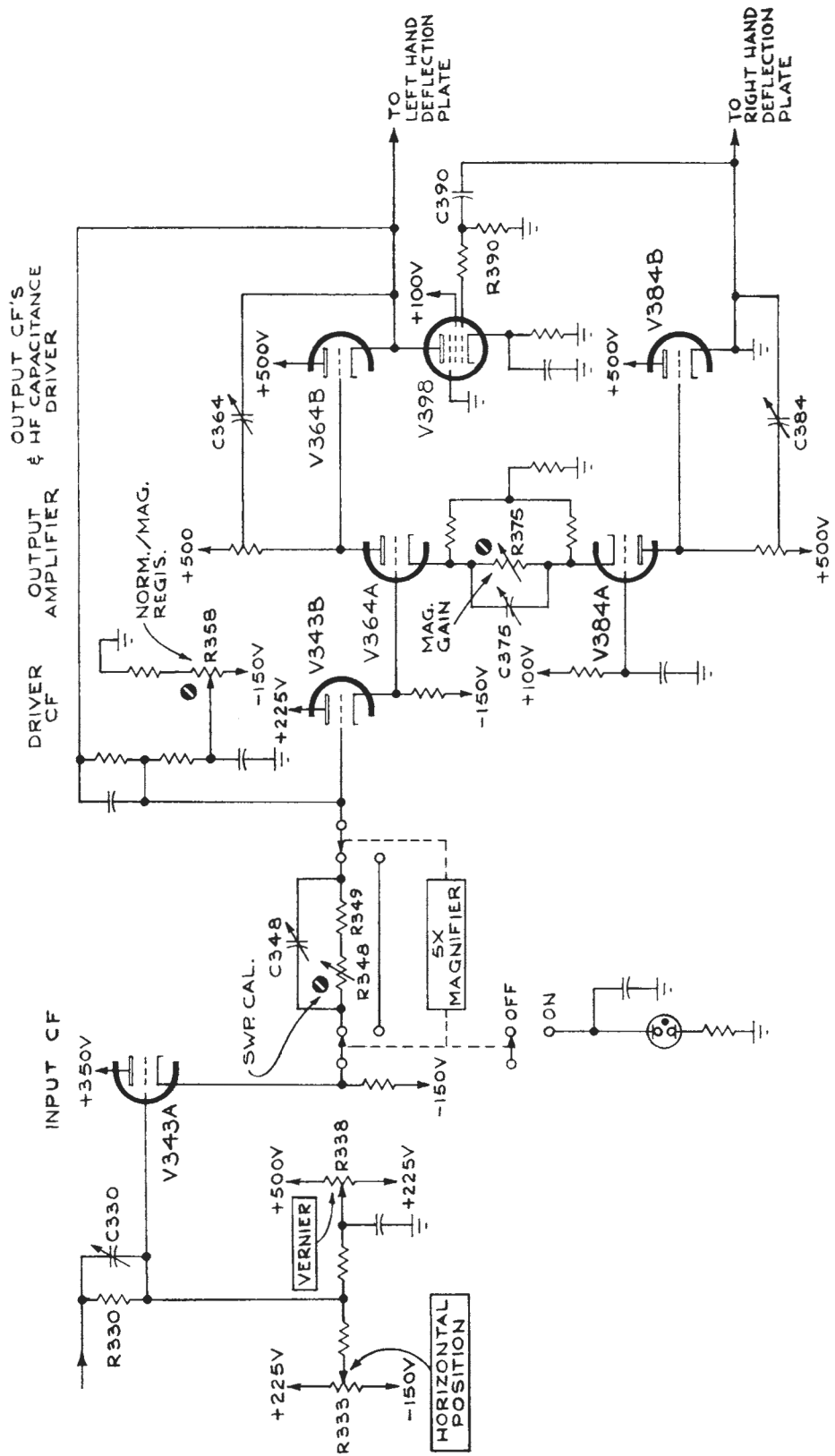

Fig. 4-7. Simplified Horizontal Amplifier.

Circuit Description — Type 545A

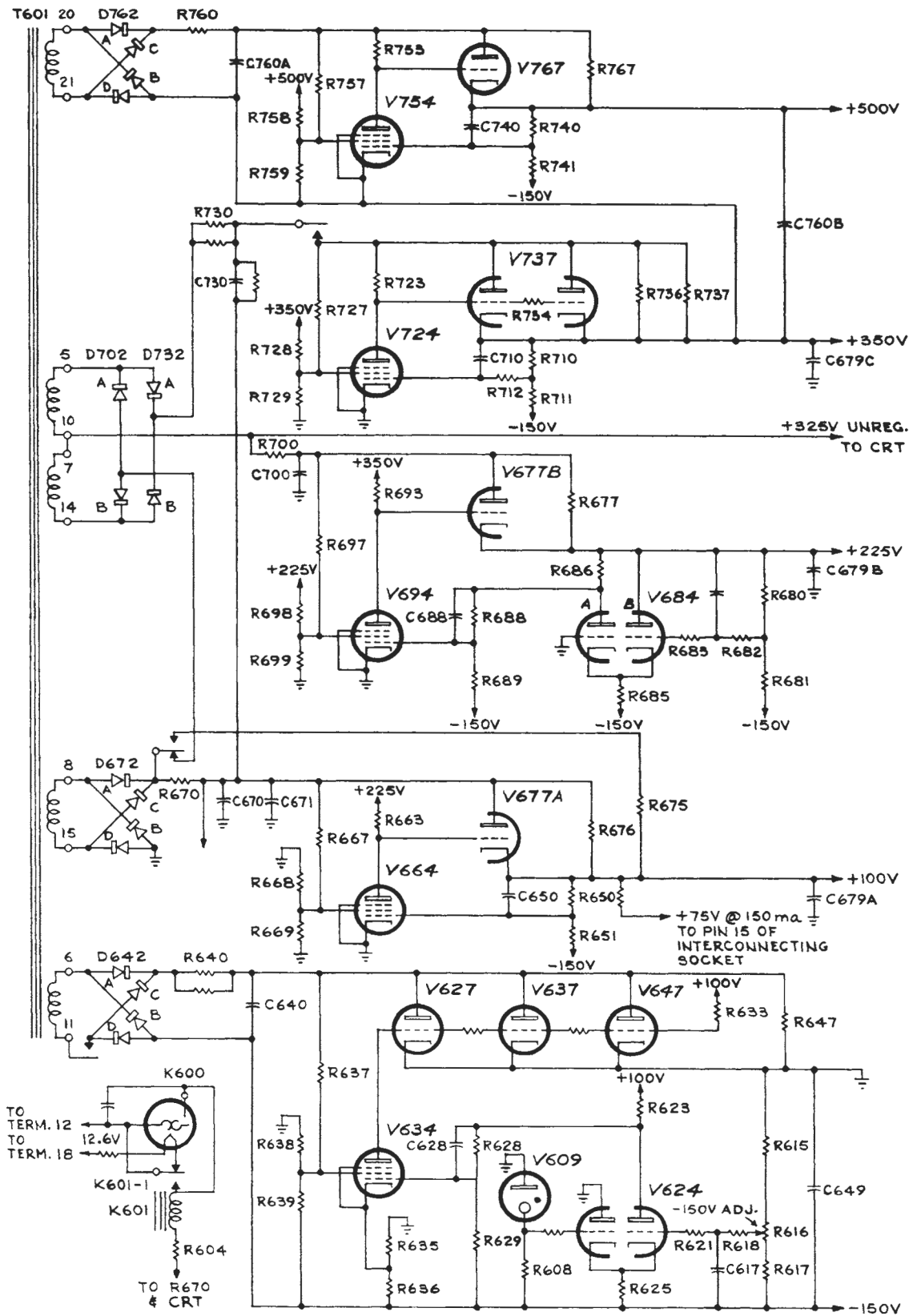
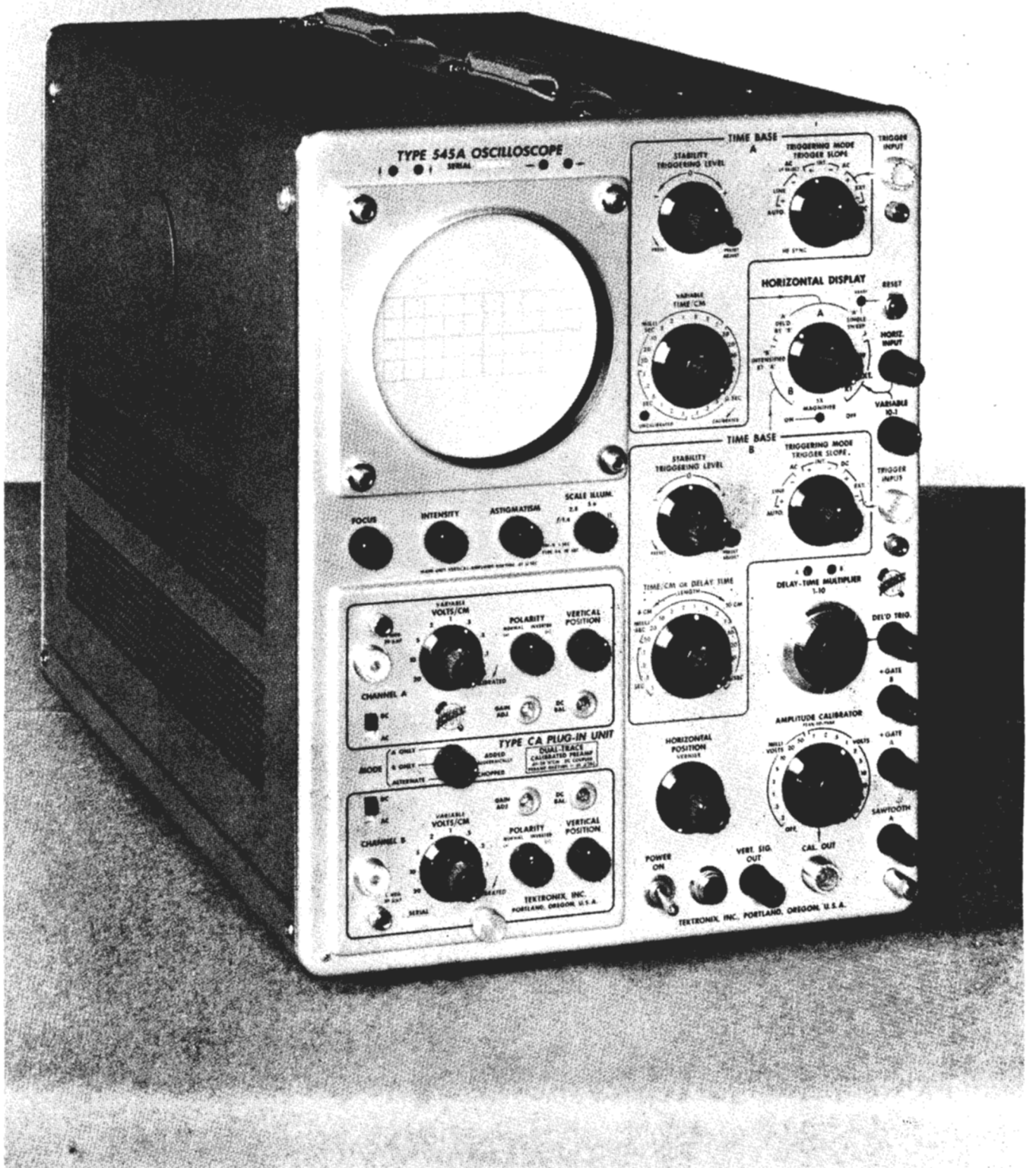

Fig. 4-8. Simplified Low-Voltage Power Supply.



Type 545A

CALIBRATOR

The Calibrator is a square-wave generator whose approximately 1-kc output is available at a front-panel connector labeled CAL. OUT. It consists of a multivibrator V875 and V885A connected so as to switch the cathode follower V885B between two operating states . . . cutoff and conduction.

During the negative portion of the Multivibrator waveform the grid of V885B is driven well below cutoff and its cathode rests at ground potential. During the positive portion of the waveform V875 is cut off and its plate rests slightly below +100 volts. The voltage at the plate of V875 when this tube is cut off, is determined by the setting of the Cal. Adj. control R879, part of the divider connected between +100 volts and ground.

Cathode-follower V885B has a precision, tapped divider for its cathode resistor. When the Cal. Adj. control is properly adjusted, the cathode of V885B is at +100 volts when V875 is cut off. By means of the tapped divider R885 through R893 and a second 1000/1 divider R896-R897, output voltages from .2 millivolts to 100 volts, in steps, are available. C885, connected between the cathode of V885B and ground, corrects the output waveform for a slight overshoot.

CRT CIRCUITS

Cathode-Ray Tube Control Circuits

The INTENSITY control R826 varies the voltage at the grid of the crt to control the beam current. The FOCUS control R856 varies the voltage at the focusing ring to focus the trace. The ASTIGMATISM control R864 varies the voltage at the astigmatism anode to focus the spot in both dimensions simultaneously. The Geom Adj. R861 varies the field the beam encounters as it emerges from the deflection system to control the linearity at the extremes of deflection.

The CRT CATHODE SELECTOR switch SW848 connects the cathode of the crt through C848 to either a rear-panel binding post labeled EXTERNAL CRT CATHODE or to the plate of V154B in the Time-Base Generator circuit. When in the DUAL-TRACE CHOPPED BLANKING position, the cathode of the crt is connected to receive positive pulses from the Time-Base Generator circuit to blank the crt during switching while operating a dual-trace plug-in unit in the chopped mode.

When SW848 is in the EXTERNAL CRT CATHODE position, the cathode circuit of the crt is connected to the binding post mentioned previously. A bare bus bar normally connects the binding post to ground. When intensity modulation of the beam is desired, the bus bar can be removed so that the modulating signal can be coupled to the crt cathode.

High-Voltage Supply

A single 60-kc Hartley oscillator furnishes power for the three power supplies that provide accelerating potentials for the crt. The main components in the Oscillator circuit are the pentode V800 and the primary of T801 tuned by C808. A half-wave rectifier V862 provides -1350 volts for the crt cathode. A half-wave voltage-tripler circuit, V832, V842, and V852, provides +8650 volts for the post-anode accelerator. This provides a total accelerating voltage of 10,000 volts. Both supplies are tied to the +100-volt regulated supply through the decoupling filter R801-C801.

A floating half-wave rectifier V822 furnishes bias voltage (about -1450 volts) for the crt grid. This floating grid supply, independent of the cathode supply, is required in order to provide dc-coupled unblanking to the crt grid. All three supplies employ capacitor-input filters.

The -1350-volt cathode supply is regulated by comparing to the -150-volt regulated supply (the cathode of V814B) a voltage near -150 volts obtained from a tap on the divider connected between the decoupled +100-volt bus and the -1350-volt bus. The total resistance of the divider, and hence the voltage across the divider, is determined by the setting of R840 labeled H.V. Adj. When this control is properly adjusted, the voltage of the H.V. Adj. Test Pt. will be exactly -1350 volts.

If variations in loading should tend to change the voltage on the -1350-volt bus, an error signal will exist between the grid and cathode of V814B. The error signal will be amplified by V814B and V814A; the output of V814A varies the screen voltage of the oscillator tube V800, thereby controlling its output.

The -8650-volt supply and the negative bias supply are regulated indirectly, as the output voltage of all three supplies is proportional to the output of the Oscillator circuit.

Unblanking

As mentioned previously, dc-coupled unblanking is accomplished by employing separate power supplies for the grid and cathode of the crt. The unblanking pulses from the Time-Base Generator are transmitted to the crt grid through the cathode follower, V183B and the floating grid supply.

At the faster sweep rates the stray capacitance in the circuit makes it difficult to pull up the floating supply fast enough to unblank the crt in the required time. To overcome this, an isolation network composed of C827, R827, and R828 is employed. By this arrangement the fast leading edge of the unblanking pulse is coupled through C827 to the grid of crt. For short-duration unblanking pulses, at the faster sweep rates, the power supply itself is not appreciably moved.

The longer unblanking pulses, at the slower sweep rates, charge the stray capacitance in the circuit through R827. This pulls up the floating supply and holds the grid at the unblanked potential for the duration of the unblanking pulse.

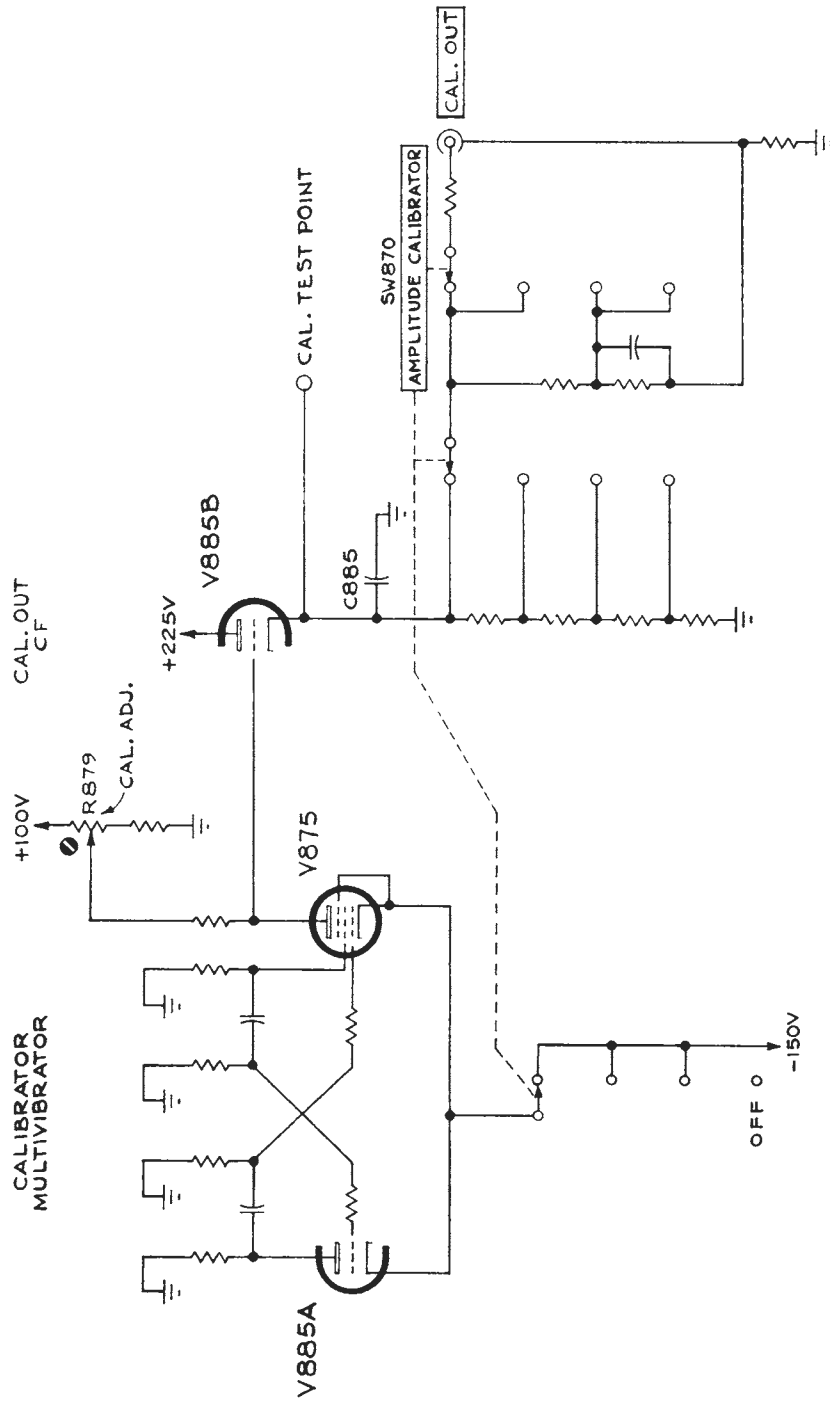

Fig. 4-9. Simplified Calibrator Circuit.

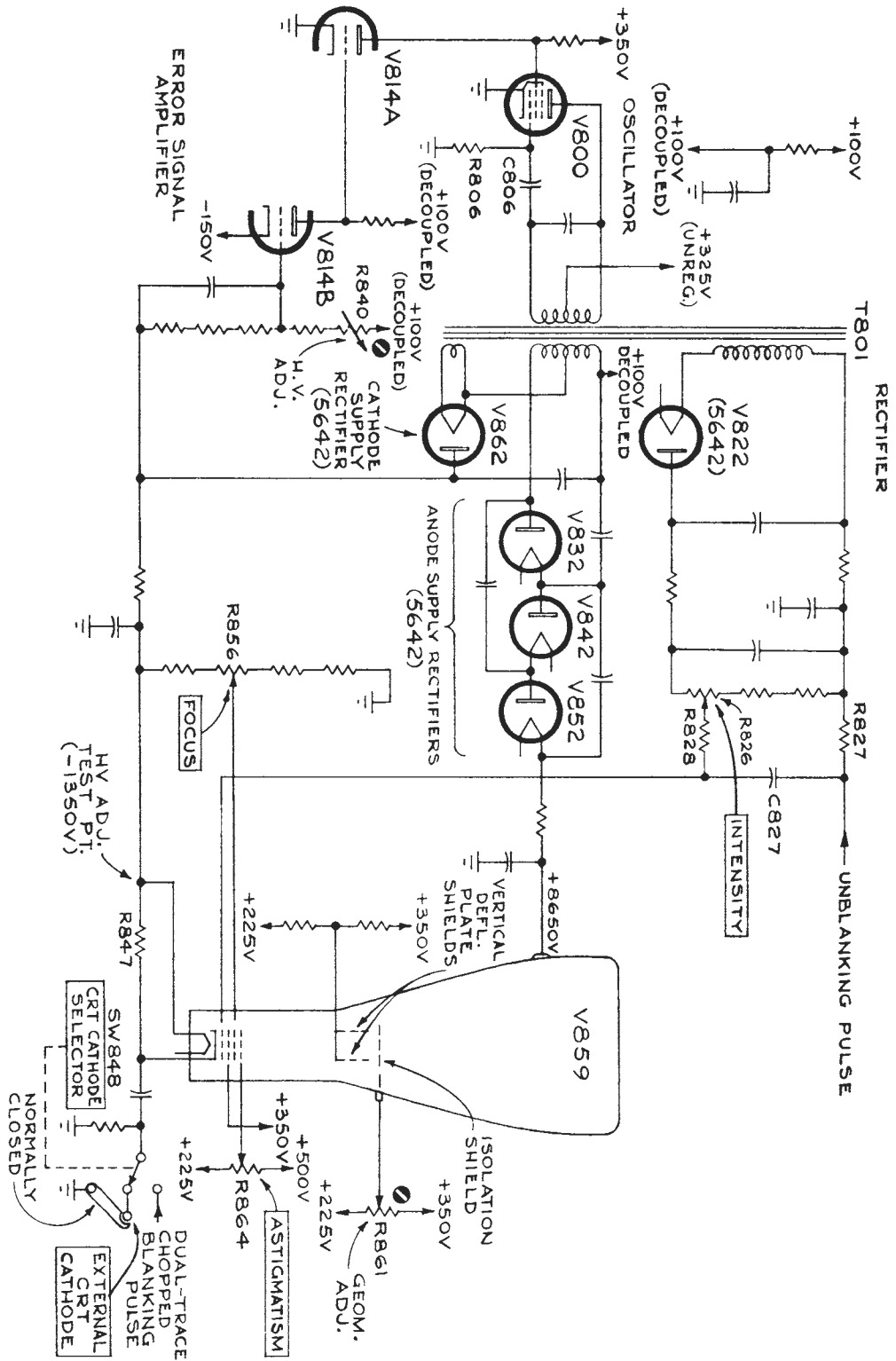
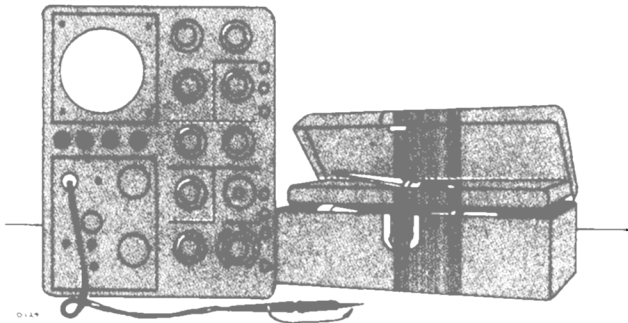

Fig. 4-10. Simplified Cathode-Ray Tube Circuit.

MAINTENANCE



PREVENTIVE MAINTENANCE

Air Filter

Care must be taken to assure free ventilation of the Type 545A inasmuch as some of the components are operated at dissipation levels such that excessive interior temperatures will result without adequate air circulation. To assure free passage of air the instrument must be placed so that the air intake is not blocked and the filter must be kept clean. Moreover, the side panels and bottom cover must be in place for proper air circulation. Do not remove covers except during maintenance.

A washable EZ KLEEN filter is used at the air intake port of the instrument. Under normal operating conditions the filter should be inspected and cleaned if necessary every three to four months. More frequent inspection is required when the operating conditions are more severe.

The following cleaning instructions are issued by the filter manufacturer:

- (1) If grease or dirt load is light, remove filter from installation and rap gently on hard surface to remove

loose dirt. Flush remaining dirt or grease out of filter with a stream of hot water or steam.

- (2) If load is too heavy for treatment described in (1), prepare mild soap or detergent solution in pan or sink deep enough to cover filter when laid flat. Agitate filter up and down in solution until grease or dirt is loosened and floated off.
- (3) Rinse filter and let dry.
- (4) Dip or spray filter with fresh Filter Coat or Handi-Coater. These products are available from the local representative of the Research Products Corporation and from most air conditioner suppliers.

Fan Motor

The fan motor bearings should be lubricated every three or four months with a few drops of light machine oil (see Fig. 5-1). Failure to lubricate the bearings periodically will cause the fan to slow down or stop thereby causing the instrument to overheat. If your oscilloscope is equipped with a dc fan motor — modification number 101 — and if

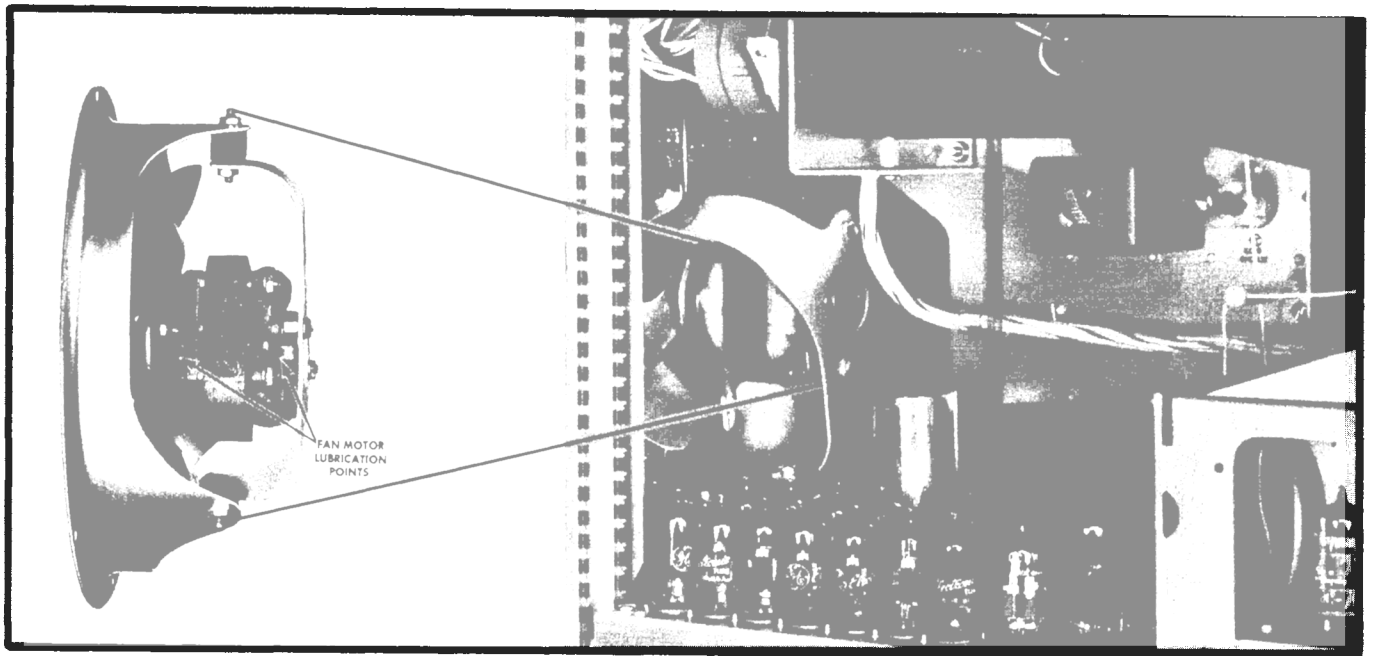

Fig. 5-1. Location of the fan motor lubrication points.

Maintenance — Type 545A

it operates throughout the working day, we suggest that you oil the bearings lightly once a month.

You should check the condition of the brushes of dc fans every other month since their life expectancy is approximately 6 months under conditions of daily use.

Fan Connections

The cooling fan is powered by a 117-volt ac motor. When the instrument is operating from a 117-volt line source, the fan is connected as illustrated in Fig. 5-2. The ceramic strip shown in the illustration is located adjacent to one corner of the power transformer.

If the instrument is converted to operate from a 234-volt line source, one of the fan connections must be changed so that the fan can operate from a 117-volt source. To make the change, unsolder the fan lead in the fifth slot at the ceramic strip, lift it free, and move it to the third slot as illustrated by the dotted line in Fig. 5-2. Use silver-bearing solder to solder the lead into the slot. The other fan lead connected at the second slot is not changed during the conversion from one line voltage to the other.

Visual Inspection

You should visually inspect the entire oscilloscope every few months for possible circuit defects. These defects may include such things as loose or broken connections, damaged binding posts, improperly seated tubes, scorched wires or resistors, missing tube shields, or broken terminal strips.

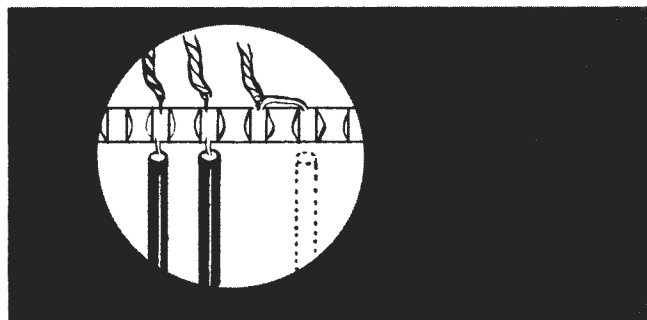
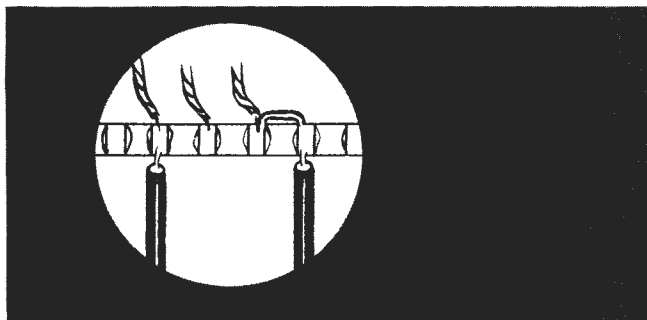

Fig. 5-2. Fan connections for 117 V ac operation. The dotted line indicates the fan lead change required for operation on 234 V ac.

For most visual troubles the remedy is apparent; however, particular care must be taken when heat-damaged components are detected. Overheating of parts is often the result of other, less apparent, defects in the circuit. It is essential that you determine the cause of overheating before replacing heat-damaged parts in order to prevent further damage.

Soldering and Ceramic Strips

Many of the components in your Tektronix instrument are mounted on ceramic terminal strips. The notches in these strips are lined with a silver alloy. Repeated use of excessive heat, or use of ordinary tin-lead solder will break down the silver-to-ceramic bond. Occasional use of tin-lead solder will not break the bond if excessive heat is not applied.

If you are responsible for the maintenance of a large number of Tektronix instruments, or if you contemplate frequent parts changes, we recommend that you keep on hand a stock of solder containing about 3% silver. This type of solder is used frequently in printed circuitry and should be readily available from radio-supply houses. If you prefer, you can order the solder directly from Tektronix in one-pound rolls. Order by Tektronix part number 251-514.

Because of the shape of the terminals on the ceramic strips it is advisable to use a wedge-shaped tip on your soldering iron when you are installing or removing parts from the strips. Fig. 5-3 will show you the correct shape for the tip of the soldering iron. Be sure to file smooth all surfaces of the iron which will be tinned. This prevents solder from building up on rough spots where it will quickly oxidize.

When removing or replacing components mounted on the ceramic strips you will find that satisfactory results are obtained if you proceed in the manner outlined below.

1. Use a soldering iron of about 75-watt rating.
2. Prepare the tip of the iron as shown in Fig. 5-3.

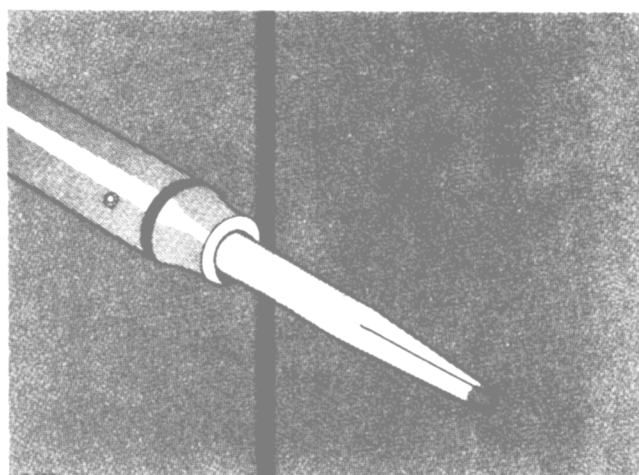

Fig. 5-3. Soldering iron tip properly shaped and tinned.

3. Tin only the first 1/16 to 1/8 inch of the tip. For soldering to ceramic terminal strips tin the iron with solder containing about 3% silver.
4. Apply one corner of the tip to the notch where you wish to solder (see Fig. 5-4).
5. Apply only enough heat to make the solder flow freely.
6. Do not attempt to fill the notch on the strip with solder; instead, apply only enough solder to cover the wires adequately, and to form a slight fillet on the wire as shown in Fig. 5-5.

In soldering to metal terminals (for example, pins on a tube socket) a slightly different technique should be employed. Prepare the iron as outlined above, but tin with ordinary tin-lead solder. Apply the iron to the part to be soldered as shown in Fig. 5-6. Use only enough heat to allow the solder to flow freely along the wire so that a slight fillet will be formed as shown in Fig. 5-5.

General Soldering Considerations

When replacing wires in terminal slots clip the ends neatly as close to the solder joint as possible. In clipping the ends of wires take care the end removed does not fly across the room as it is clipped.

Occasionally you will wish to hold a bare wire in place as it is being soldered. A handy device for this purpose is a short length of wooden dowel, with one end shaped as

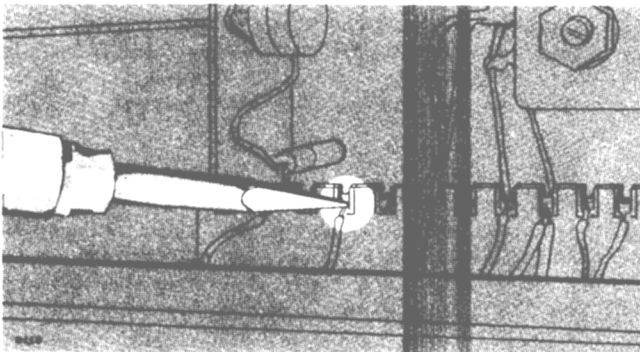

Fig. 5-4. Correct method of applying heat in soldering to a ceramic strip.

shown in Fig. 5-7. In soldering to terminal pins mounted in plastic rods it is necessary to use some form of "heat sink" to avoid melting the plastic. A pair of long-nosed pliers (see Fig. 5-8) makes a convenient tool for this purpose.

Ceramic Strips

Two distinct types of ceramic strips have been used in Tektronix instruments. The earlier type mounted on the chassis by means of #2-56 bolts and nuts. The later type

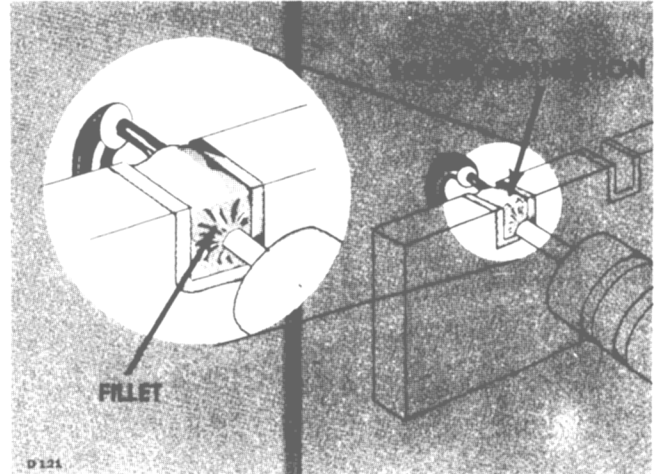

Fig. 5-5. A slight fillet of solder is formed around the wire when heat is applied correctly.

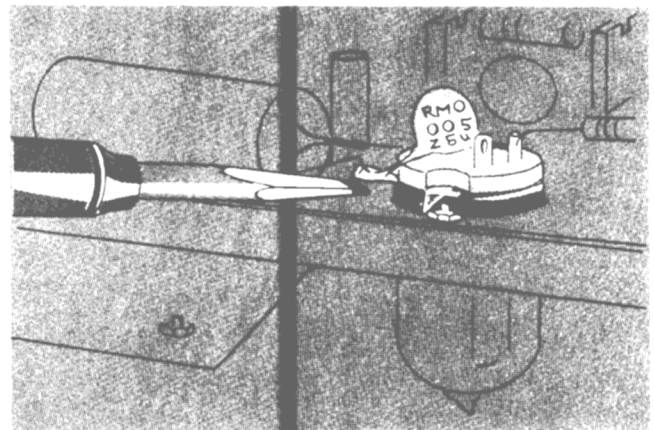

Fig. 5-6. Soldering to a terminal. Note the slight fillet of solder—exaggerated for clarity—formed around the wire.

is mounted with snap-in, plastic fittings. Both styles are shown in Fig. 5-9.

To replace ceramic strips which bolt to the chassis, screw a #2-56 nut onto each mounting bolt, positioning the bolt so that the distance between the bottom of the bolt and the bottom of the ceramic strip equals the height at which you wish to mount the strip above the chassis. Secure the nuts to the bolts with a drop of red glyptal. Insert the bolts through the holes in the chassis where the original strip was mounted, placing a #2 starwasher between each nut and the chassis. Place a second set of #2 flatwashers on the protruding ends of the bolts, and fasten them firmly with another set #2-56 nuts. Place a drop of red glyptal over each of the second set of nuts after fastening.

Mounting Later Ceramic Strips

To replace strips which mount with snap-in plastic fittings, first remove the original fittings from the chassis.

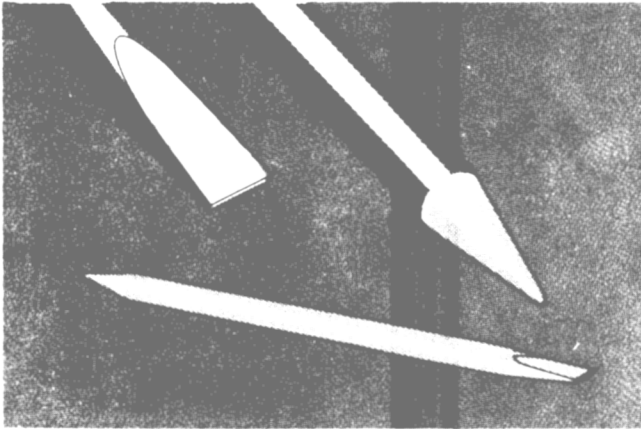

Fig. 5-7. A soldering aid constructed from a 1/4 inch wooden dowel.

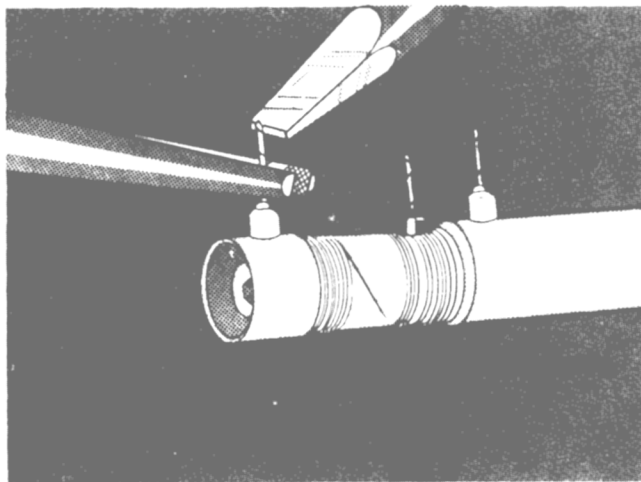

Fig. 5-8. Soldering to a terminal mounted in plastic. Note the use of the long-nosed pliers between the iron and the coil form to absorb the heat.

Assemble the mounting post on the ceramic strip. Insert the nylon collar into the mounting holes in the chassis. Carefully force the mounting post into the nylon collars. Snip off the portion of the mounting post which protrudes below the nylon collar on the reverse side of the chassis.

NOTE

Considerable force may be necessary to push the mounting rods into the nylon collars. Be sure that you apply this force to that area of the ceramic strip directly above the mounting rods.

L.V. Power Transformer Connections

Unless tagged otherwise your instrument is connected at the factory for operation at 105 to 125 volts, 50 to 60 cycles ac, (117 volts nominal). However, provisions are made for easy conversion to operation at 210 to 250 volts, 50 to 60 cycles (234 volts nominal). The power transformer

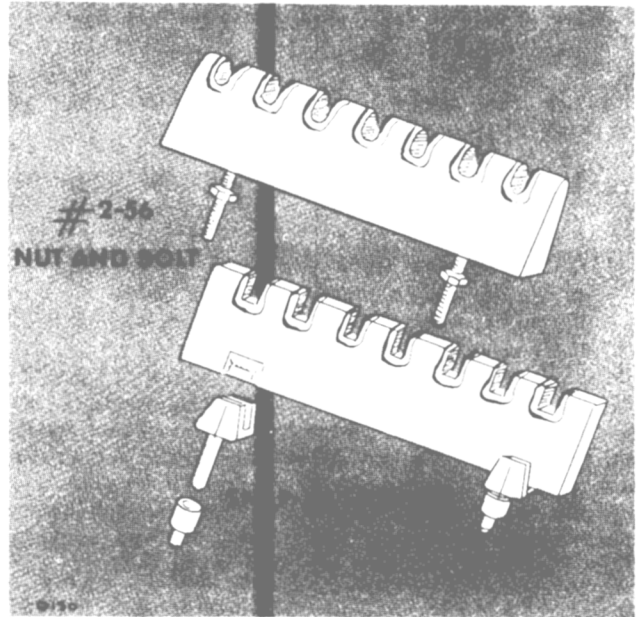

Fig. 5-9. Two types of ceramic strip mountings.

T601 is provided with split input windings which are normally connected in parallel for 117-volt operation but which can be connected in series for 234-volt operation. Each of these split windings terminates in a group of four terminal lugs arranged in a square on the underside of the transformer, and numbered 1, 2, 3, and 4 in a clockwise direction.

Terminals 1 and 3 are connected to one winding and terminals 2 and 4 are connected to the second winding. The ac input leads are connected to terminals 1 and 4 for both 117-volt and 234-volt operation, so these connections do not have to be changed when converting from one line voltage to the other.

When wired for 117-volt operation terminals 1 and 2 are joined by a bare bus wire and terminals 3 and 4 are similarly joined, as shown in Fig. 5-10 (a). To convert to 234-volt operation remove the bare bus wires between these terminals and substitute a single connecting wire between terminals 2 and 3, as shown in Fig. 5-10 (b).

TROUBLESHOOTING PROCEDURE

This section of the manual contains information for troubleshooting your oscilloscope. Before attempting to troubleshoot the instrument, however, make sure that any apparent trouble is actually due to a malfunction within the instrument and not to improper control settings or to a faulty plug-in unit. Instructions for the operation of the oscilloscope and general information concerning plug-in operation, are contained in the Operating Instructions section of this manual. Operating instructions for a specific plug-in unit will be found in the manual for that unit.

To determine that the oscilloscope is at fault, the plug-in unit may be replaced with another known to be in good

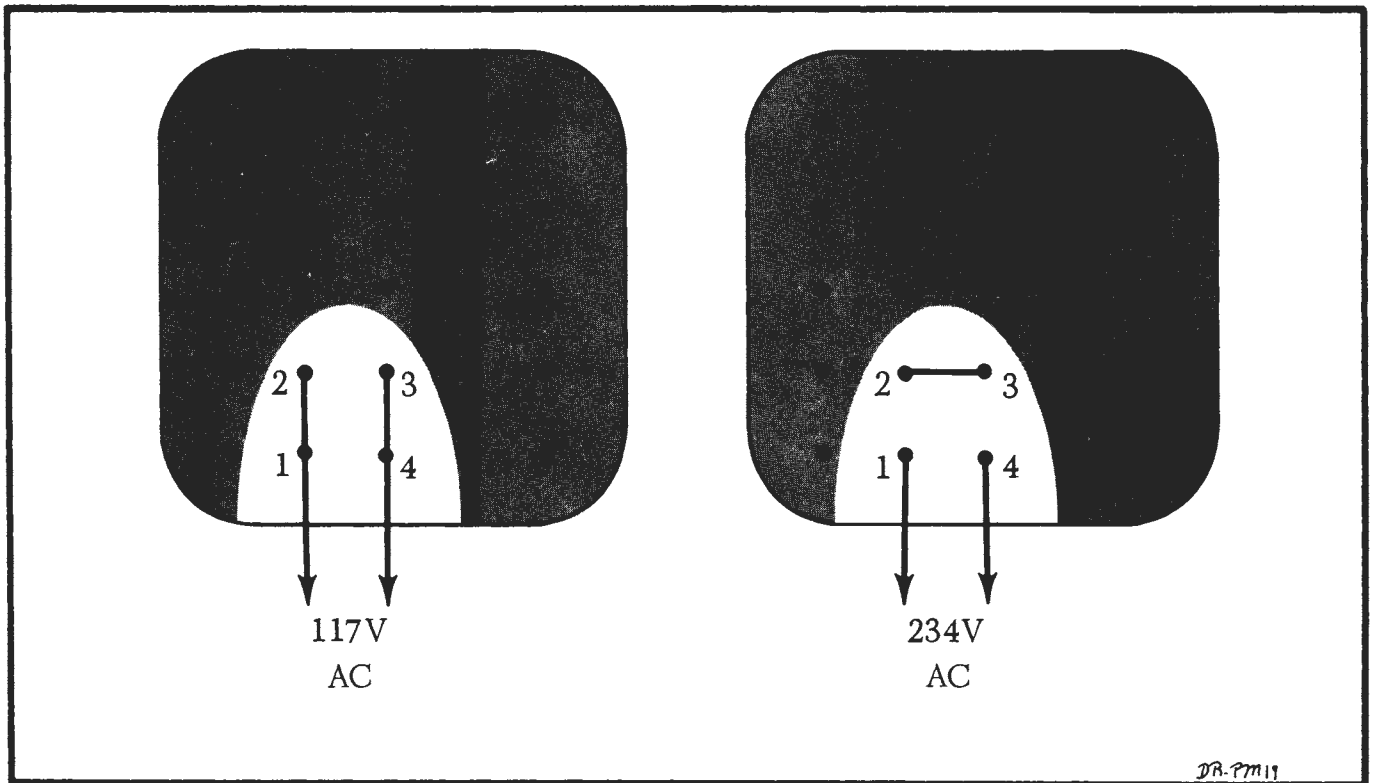

Fig. 5-10. Converting the power transformer from 105-125 volt operation to 210-250 volt operation.

operating condition. If the trouble is still apparent, it is almost a certainty that the oscilloscope is at fault. However, should the trouble appear to have been corrected by replacing the plug-in unit, the trouble most likely lies within the original plug-in unit and not with the oscilloscope.

Tube failure is the most prevalent cause of circuit failure. For this reason, the first step in troubleshooting any circuit in the instrument is to check for defective tubes, preferably by direct substitution. Do not depend on tube testers to adequately indicate the suitability of a tube for certain positions within the instrument. The criterion for usability of a tube is whether or not it works satisfactorily in the instrument. Be sure to return all good tubes to their sockets; if this procedure is followed less recalibration of the instrument will be required upon completion of the servicing.

When replacing any tube in the instrument, check first to see that components through which the tube draws current have not been damaged. Shorted tubes will sometimes overload and damage plate-load and cathode resistors. These damaged components can generally be located by a visual inspection of the wiring. If no damaged components are apparent, and if tube replacement does not restore operation, it will be necessary to make measurements or other checks within the circuit to locate the trouble.

The component number of each resistor, inductor, capacitor, vacuum tube, control and switch is shown on the circuit diagrams. The following chart lists the component numbers associated with each circuit:

- All numbers less than 100 Time-Base Trigger
- 100 series Time-Base Generator

- 200 series Time-Base Generator B
- 300 series Horizontal Amplifier
- 400 series Delay Pickoff
- 600 series and 700 series Low-Voltage Power Supply
- 800 series CRT Circuits and High-Voltage and Square-Wave Calibrator
- 1000, 1100, 1200 series . Vertical Amplifier
- 1300 series Delay Line

Switch wafers shown on the schematic diagrams are coded to indicate the position of the wafer on the actual switches. The number portion of the code refers to the wafer number on the switch assembly. Wafers are numbered from the front of the switch to the rear. The letters F and R indicate whether the front or the rear of the wafer is used to perform the particular switching function. Photographic details of these switches are shown on the same fold-out page as the corresponding schematic diagram. These photographs are provided as parts location guides.

CIRCUIT TROUBLESHOOTING

Although the Type 545A is a complex instrument, it can be thought of as consisting of eight main circuits, in addition to the Calibrator circuit. These are the:

1. Low-Voltage Power Supply.
2. CRT Circuit and High-Voltage Power Supply.

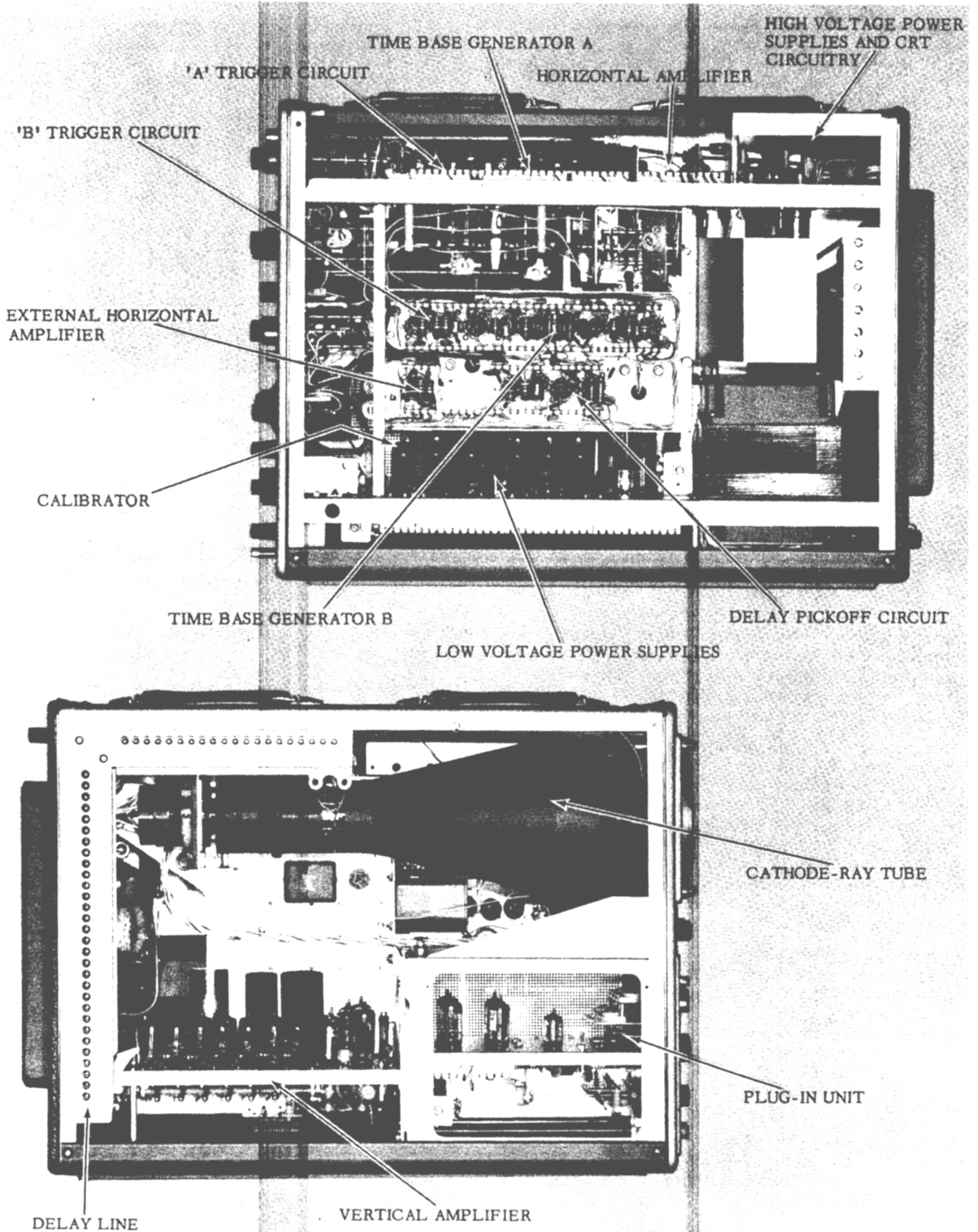

Fig. 5-11. Physical location of the circuits which compose the Type 545A Oscilloscope.

3. Vertical Amplifier and Delay Line.
4. Time-Base "A" Trigger Circuit.
5. Time-Base "B" Trigger Circuit.
6. Time-Base "A" Generator.
7. Time-Base "B" Generator.
8. Horizontal Amplifier.

The first circuit to check, for practically any type of trouble, is the Low-Voltage Power Supply. Because of the circuit configuration employed, it is possible for an improper power supply voltage to affect one circuit more than the others. For example, if the gain of the Vertical Amplifier should decrease slightly, while the other circuits appear to be functioning normally, this could be due to an improper supply voltage and not to any condition originating in the Vertical Amplifier. In cases of this type, valuable time can be saved by checking the power supply first.

On the other hand, the crt display can often be used to isolate trouble to one particular circuit when trouble obviously exists in that circuit. If there is no vertical deflection, for example, when the intensity and horizontal deflection appear to be normal, it is apparent that an open condition exists in the Vertical Amplifier and this circuit should be investigated first.

Front-Panel Checks

The following front-panel checks will help you to isolate the trouble in an instrument to a given circuit. The interrelation between circuits is such that these checks are not always completely accurate in isolating a trouble to a given circuit. If you are unfamiliar with the instrument these front-panel checks may prove helpful in starting to look for the trouble.

Before attempting any of the following front-panel checks make sure that the plug-in installed in the instrument is operating correctly. If the pilot lamp fails to light when the POWER switch is turned on to the ON position, and if the fan fails to operate, turn to the section on troubleshooting the Low-Voltage Power Supply. If the pilot light and fan both operate but the Time-Delay Relay fails to operate with an audible "click" after one minute you should also consult the section on Troubleshooting the Low-Voltage Power Supply.

With an operating plug-in installed, and the pilot light and fan both operating, allow the oscilloscope to run for several minutes.

Set the front-panel controls as follows:

STABILITY	full right (clockwise)
TRIGGERING LEVEL	0
TRIGGERING MODE	AC
TRIGGER SLOPE	+INT.
VARIABLE (TIME/CM)	full right
TIME/CM	5 MILLISEC
HORIZONTAL DISPLAY	A
FOCUS	mid-scale

INTENSITY	full-left (counterclockwise)
ASTIGMATISM	mid-scale
SCALE ILLUMINATION	mid-scale
HORIZONTAL POSITION	mid-scale
VERNIER	mid-scale

The settings of other controls are not critical at this time.

If you are using a Type TU1 or TU2 Test-Load Plug-in Unit set the toggle switch to the 1:1 position and the AMPLITUDE CALIBRATOR switch to the .2 VOLTS position. If using another type of plug-in set the VOLTS/CM switch to 1 volt and the AMPLITUDE CALIBRATOR switch to 2 VOLTS.

Using a patch cord which introduces no attenuation connect the CAL. OUT connector to the INPUT connector of the plug-in preamplifier. Advance the INTENSITY control to the mid-scale position.

Now examine the face of the crt. If no display is evident examine the Beam-Position Indicator lamps. If the display is positioned off the screen vertically turn the VERTICAL POSITION control from one extreme position to the other, watching the face of the crt as you do so. If no display appears, and operation of the VERTICAL POSITION control has no effect on the Beam-Position Indicator lamps turn to the section on Troubleshooting the Vertical Amplifier.

If the display which appears consists of a horizontal line, you may check the operation of the calibrator by removing the end of the patch cord which is inserted into the CAL. OUT connector and holding it in your hand. A series of sloping vertical lines appearing on the crt indicate that the Vertical Amplifier is operating, and that the Amplitude Calibrator is probably inoperative. See the section on Troubleshooting the Amplitude Calibrator for the remedy.

If the operation of the VERTICAL POSITION control causes the vertical Beam-Position Indicator lamps to indicate the display as centered, rotate the HORIZONTAL POSITION control from one extreme position to the other. If the horizontal Beam-Position Indicator lamps still indicate the display is off the screen refer to the section on Troubleshooting the Horizontal Amplifier.

If both sets of Beam Position lamps indicate that the display is centered, but no display is observed, CAUTIOUSLY advance the INTENSITY control. Watch for a display to appear on the screen. If no display is seen or if the display is of low intensity but otherwise normal, refer to the section on Troubleshooting the CRT Circuit.

TROUBLESHOOTING THE VERTICAL AMPLIFIER

No Spot or Trace Visible on CRT

If all power supply voltages are normal, and the crt is known to be good, failure to obtain a spot or trace on the screen will be due to improper positioning voltages. This condition is caused by a dc unbalance in either or both of the deflection amplifier circuits.

Maintenance — Type 545A

To determine which circuit is at fault, adjust the Time-Base controls for a free-running sweep at 1 millisc/cm (STABILITY control full right). Set the INTENSITY control to midscale. Using a screwdriver with an insulated handle, short the deflection plates together at the neck pins on the crt. These are the pins marked BLUE (UPPER) and BROWN (LOWER). Be extremely careful not to short either pin to the metal shield around the crt, or to the pin marked ORANGE (GEOM). If the dc unbalance is being produced in the vertical deflection circuit the trace will appear at or near the center of the crt when the vertical deflection plates are shorted together. If the trace does not appear, however, the trouble does not lie in the vertical circuit and the dc balance of the horizontal circuit can be checked in a like manner.

If it is determined that the vertical deflection circuit is unbalanced, the next step is to check the Delay Line. For this check, and for others to follow, it is convenient to have a short lead (about 6 to 10 inches) with a rubber-covered alligator clip on each end (see Fig. 5-12). Connect this lead across the input to the Delay Line (at the output from the Distributed Amplifier). If the trace appears on the crt the Delay Line is not at fault. If the trace does not appear, check for an open line. This can be done by turning off the instrument and checking the continuity of both sides of the line with an ohmmeter.

If the Delay Line is not at fault, connect the shorting strap across the input of the Distributed Amplifier. If the trace does not appear when these grids are connected together, the trouble lies in the Distributed Amplifier. Check for an open grid or plate line. Check R1206 and R1216 at the grid line termination, and check R1071 and R1073 and the associated circuitry at the plate line termination. Refer to the simplified diagram of a distributed amplifier shown in Fig. 4-1 for the location of these components: then

refer to the schematic diagram for your instrument for the exact value. Fig. 4-1 shows the normal location of these components in a vertical amplifier.

If the trouble is being caused by tubes, it may help to connect the shorting strap between the grids of that pair of distributed amplifier tubes closest to the input of the delay line. Then move the shorting strap back stage-by-stage toward the input of the distributed amplifier until a point is reached at which the trace no longer appears as the opposite grids are shorted together.

The trouble will then lie in that part of the circuit between the shorting strap and the Delay Line. It is unlikely that just one tube in the Distributed Amplifier could be responsible for the trouble because the current from each tube is only a small portion of the total current flowing in the plate circuit.

If the trace appears when the input grids to the Distributed Amplifier are connected together, the trouble is occurring ahead of the Distributed Amplifier in one of the input stages. If the tube replacement does not correct the trouble, then look for open peaking coils, defective resistors, and shorted or leaky capacitors.

After replacing tubes in the distributed amplifier or other sections of the Type 545A vertical amplifier, it is necessary to check the various stages for balance between paired tubes on opposite sides of the amplifier. To check the balance of the 6DK6 stages, insert a Type TU-2 Test Load Unit in your oscilloscope. Short together the vertical deflection plates of the CRT to determine the Electrical Center and adjust VERTICAL POSITIONING so that the trace is at the electrical center. Jumper the grid lines of the 6DK6 stages together. Then attach a meter lead or suitable connector between the +225 volt output of the TU-2 and the cathodes of each pair of 6DK6 tubes in order. Unbalance of the

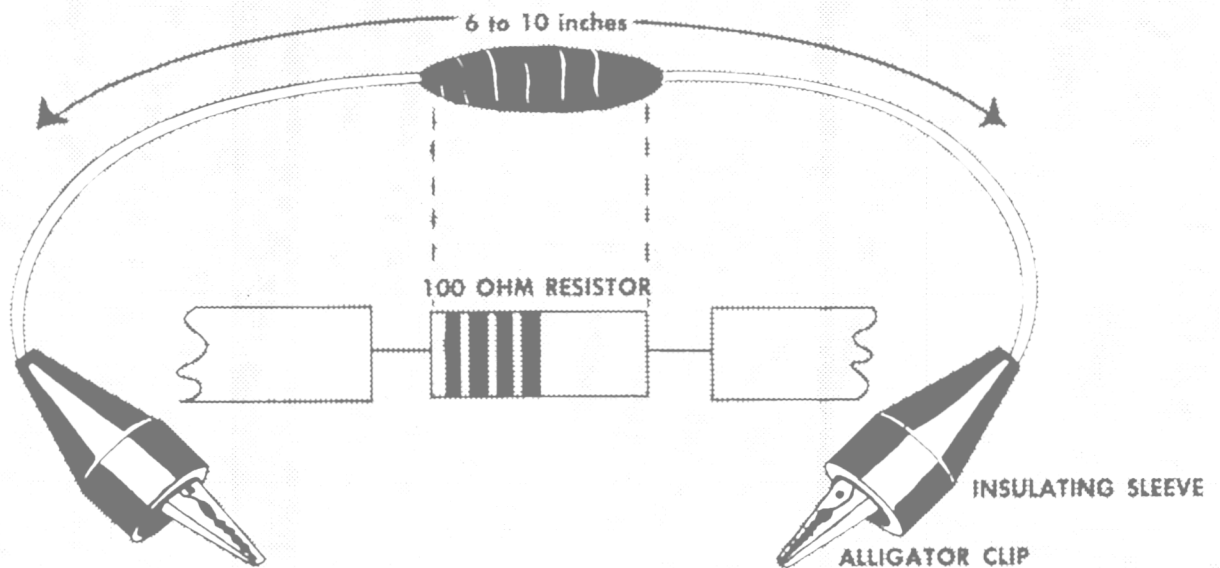

Fig. 5-12. Shorting strap useful in locating an unbalanced stage in vertical or horizontal amplifier. Insulating tape covers the 100-ohm resistor.

stage is indicated by a sudden shift in vertical location of the crt trace. Balancing should begin with the last pair of tubes toward the rear of the oscilloscope and continue successively toward the front. By interchanging tubes from side to side and between pairs, unbalance should be reduced to a minimum in the 6DK6 stage. Then proceed forward to the 6DJ8 tubes following the same procedure to obtain a minimum of unbalance. Matching of the 12BY7 stage is most critical of all. This can be accomplished by simply placing a jumper between the 12BY7 grids and pushing the ZERO REFERENCE button on the front of the TU-2.

Insufficient or No Vertical Deflection

Insufficient deflection indicates a change in the gain characteristics of the Vertical Amplifier. If only a slight change in deflection is apparent, the circuit can normally be recalibrated for gain. In this event, refer to the Calibration Procedure section of this manual.

If the change in deflection is more pronounced, or if there is no deflection at all, the tubes should first be checked. Then check for components which can affect the gain of the circuit but not the dc balance. Such components would be the common cathode resistors and the GAIN ADJ. control; common screen resistors and common plate load resistors.

Waveform Distortion

Any waveform distortion produced by the distributed amplifier will generally be of high-frequency nature. There will be no low-frequency distortion since the deflection circuit is dc-coupled from input to output (unless one or more of the tubes enter into heavy grid current, a condition that will produce other types of distortion as well).

A distortion-free positive step function, having a risetime of 10 nanoseconds or less, may be used to observe the high-frequency characteristics of the oscilloscope-plug-in combination. This is illustrated in the waveform photographs of Figs. 5-13, 5-14, 5-15. Fig. 5-13 (a) shows a display of the 3-nanosecond risetime square-wave output of the Tektronix Type 107 Square-Wave Generator; this photograph was taken on a standard Type 545A Oscilloscope with a Type K Plug-In Unit. The straight leading edge, square corner and flat top are indicative of the frequency response of a properly adjusted Type 545A/K-Unit combination. Fig. 5-13 (b) shows the same waveform except for a small aberration in the top about 2 centimeters to the right of the leading corner. This aberration is known as the termination "bump", and was obtained by detuning the Delay Line termination network slightly. The oscilloscope was adjusted for a sweep rate of $.2 \mu\text{sec}/\text{cm}$ for these photographs; the termination bump therefore occurs $.4$ microsecond after the leading corner. Since the Delay Line is reverse terminated, this corresponds to twice the $.2$ -microsecond delay time of the circuit.

Any waveform distortion that may be produced by the vertical deflection circuit will occur between the leading corner and the termination bump. The vertical deflection circuit in the Type 545A may be divided into three parts, and each part will affect the waveform in a different man-

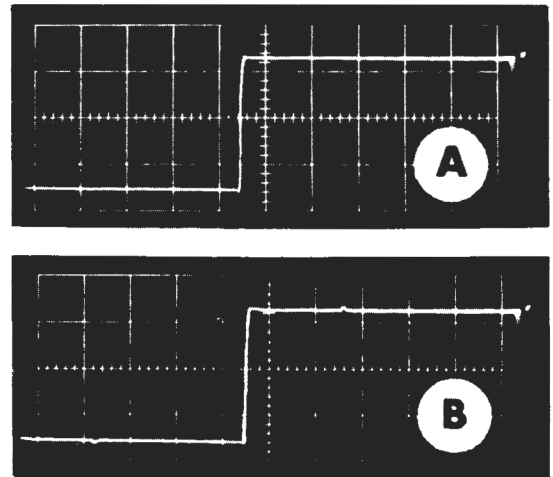

Fig. 5-13. (a). A 450-kc, 3 nanosecond risetime square wave displayed on properly adjusted Type 545A/K-unit combination. (b). The small aberration in the top of the waveform is a termination bump produced by an improperly terminated Delay Line.

ner. An analysis of the distortion is therefore helpful in determining which part of the circuit is at fault. The three parts are:

- (1) The plug-in unit and input stage of the main Vertical Amplifier.
- (2) The Distributed Amplifier.
- (3) The Delay Line.

The plug-in unit and the input stage of the main Vertical Amplifier will affect only the leading corner of the step

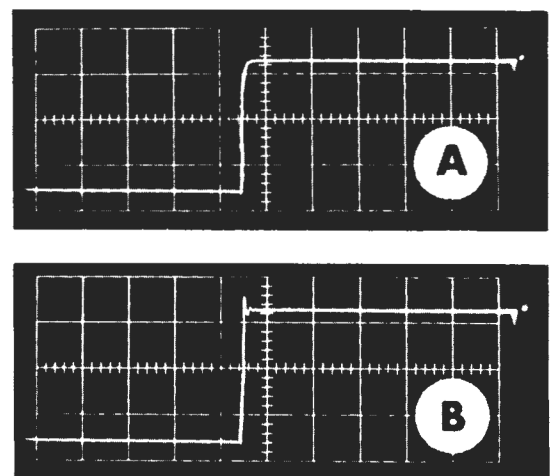

Fig. 5-14. (a). Rolloff at leading corner caused by an under-compensated Input Amplifier Stage. (b). Ringing produced by an overcompensated Input Amplifier Stage.

function. Assuming the trouble is not being caused by the plug-in unit, the Input Amplifier stage and the cathode follower circuit can be investigated for the type of distortion shown in Fig. 5-14. Fig. 5-14(a) shows rolloff, or under-shoot, at the leading corner of the step function. Rolloff is the result of insufficient high-frequency compensation. A small amount of rolloff is normally due to a change, with age, in the characteristics of the circuit components, and can usually be compensated by adjusting the variable peaking coils. If the rolloff is more pronounced the tubes should be checked. If a tube cannot deliver current, instantaneously on demand, the transients in the signal will not be produced.

Shorted or partially shorted peaking coils will result in a rolloff. Be especially careful when soldering around the peaking circuits as hot solder dropping on a coil may burn through the insulation and short the turns.

Ringing at the leading corner, shown in Fig. 5-14(b), is produced by an overcompensated amplifier. This is generally caused by misadjusting the peaking coils. An overshoot at the leading edge, without ringing, can also be produced by an over-compensated amplifier; in this case the degree of compensation is not sufficient to produce ringing. In both of these cases the distortion can generally be eliminated by readjusting the variable peaking coils.

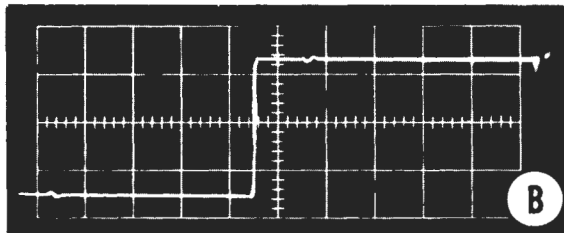
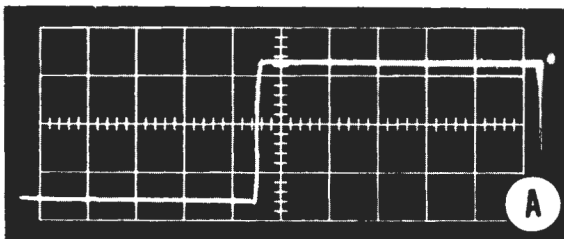

Fig. 5-15. (a). Rolloff and aberrations in top of pulse are due to a low Gm tube in the Distributed Amplifier. (b). Small aberrations in top of pulse are caused by a slightly misadjusted portion of the Delay Line.

An overshoot at the leading edge of a fast-rise pulse may also be the result of cathode interface in one of the amplifier tubes. Since the constant of the interface layer is normally in the range from .1 to 3 μ sec, this effect is most noticeable on waveforms whose period is long compared to the interface time constant. This condition is produced by the tubes themselves, so it is important to first check the tubes when such distortion is evident.

The Distributed Amplifier will affect the step function both at the leading corner and in the vicinity of the termination bump. A typical example is that shown in Fig. 5-15(a).

The rounded corner, and the aberrations about .4 μ sec following the corner, were produced by replacing V1204 with a tube whose Gm was quite low. This points up the importance of the tubes in maintaining the proper frequency response in pulse amplifiers. Other factors causing similar effects would be shorted coils in the plate and grid lines, off-value resistors, leaky or open capacitors, or improper adjustment of the capacitors across the plate lines.

The Delay Line will affect the pulse from the corner to the termination bump. If the line is badly detuned the top of the pulse will be uneven, instead of smooth and flat as shown in Fig. 5-15(a) and the leading corner may either overshoot or rolloff. If just one or two sections of the line are detuned, either due to a shorted coil or a defective capacitor, an aberration will appear in the waveform in the region affected by the defective component. Since the Delay Line is reverse-terminated, the end of the line nearest the cathode-ray tube will affect the start of the pulse, and the beginning of the line (at the output of the Distributed Amplifier) will affect the waveform in the region of the termination bump. Sections of the line between the two ends will affect the waveform in the region between the corner and the termination bump. The location of an aberration in the top of the pulse, with respect to the leading corner and the termination bump, will indicate the relative section of the line in which the trouble is occurring. For example, the small aberrations shown in Fig. 5-15(b) were produced by slightly detuning two sections of the line about midway between the Distributed Amplifier and the cathode-ray tube.

TROUBLESHOOTING THE TIME-BASE TRIGGER CIRCUIT

Unstable Triggering

If the sweep generator is not being properly triggered a stable display of a waveform will not be possible. If the sweep can be turned off and on with the STABILITY control (for any setting of the TRIGGERING MODE switch except AUTOMATIC) the sweep generator is capable of being triggered; this indicates the trigger circuitry is not functioning properly. The first step is to replace the Trigger Pickoff tube V1223 in the Vertical Amplifier. The operation of this stage can also be checked by observing the signal available at the VERT. SIG. OUT binding post with another oscilloscope. If no signal is available at this connector the Trigger Pickoff stage is defective; a proper signal at this connector indicates the stage is functioning correctly.

If the Trigger Pickoff stage is operating correctly, trouble exists in the Time-Base Trigger circuit. To check the quiescent stage of the circuit, set the TRIGGERING MODE switch to AC, the TRIGGER SLOPE switch to -INT. and the TRIGGERING LEVEL control to 0. Next, connect a jumper wire from the junction of R19, R20, and C20 (on the Trigger Switch; Fig. 6-7) to ground. This fixes the voltage at the grid of V24B at ground potential. Then measure the voltage at the plate of V24B; this should be about +85 volts. If this voltage does not measure very close to +85 volts, replace the Trigger Input tube V24. If necessary, check for off-value resistors, broken leads and poor switch contacts.

The next step is to connect the voltmeter between the plate of V24B and the grid of V45B (the junction of R41, R37, C37 and R38 is more convenient than the grid of V45B). The voltage between the plate of V24B and the grid of V45A (or the divider side of R41) should not exceed about 2.75 volts. It is the function of the Trig. Level Centering control R39 to set the voltage at the grid of V45B approximately equal to the voltage at the grid of V45A. With the grids of V45 at about the same voltage the center of the hysteresis of the Trigger Multivibrator circuit will be at the proper level. It is difficult to measure the voltage directly between the two grids of V45 due to the loading of the voltmeter; for this reason we suggest the voltage be measured between the plate of V24B and the grid circuit of V45B. A voltage of 2.5 to 2.75 volts between these points will indicate proper quiescent operation.

If the voltage at the grid of V45B cannot be adjusted to within 2.5 to 2.75 volts of the voltage at the plate of V24B, trouble in the Trigger Multivibrator is indicated. Replace the tube; then, if necessary, check for off-value resistors, broken leads and poor switch connections.

Conversely, if the voltages are found to be correct, the adjustment of the Trig. Sens. control R47 can be checked. Refer to Step (7) in the Calibration Procedure for the proper method of checking the adjustment of this control.

When triggering in the DC mode from the signal being observed (TRIGGER SLOPE at + or -INT.), the Int. Trig. DC Level Adj., R3 and its associated components are connected to the input grid of V24. This control is adjusted so that the input grid (pin 7 at -INT; pin 2 at +INT.) is at ground potential when the trace is centered vertically on the crt. If the voltage at the input grid cannot be adjusted to zero when the triggering-switch controls are in the indicated positions, this control and its associated components should be checked.

TROUBLESHOOTING THE TIME-BASE GENERATOR

No Horizontal Sweep

If the Time-Base Generator is not producing a sawtooth sweep voltage when the STABILITY control is adjusted for a free-running sweep some defect in the generator is hanging up the Miller circuit. Depending on the on-off characteristics of the diodes V152, the Miller circuit may be hung up at either the high end or the low end of the sawtooth. The manner in which it is hung up may be determined by measuring the voltage at the SAWTOOTH A binding post. If the Miller circuit is hung up at the high end of the sawtooth the voltage at the front-panel binding post will measure about +200 volts; if hung up at the low end, the voltage at this point will measure anywhere between ground and -20 to -30 volts, depending on the cause.

If the Miller circuit is hung up at the high end of the sawtooth a check of the voltage at the grid of the Miller tube will offer a clue to the cause of the trouble. The static voltage at the Miller grid is determined by conduction through the Timing Resistor, R160 (from -150-volt bus), the lower diode V152B, and the divider R147-R148. It will be

impossible to measure the exact voltage at the Miller grid because of the loading of the meter. However, if a 20,000- Ω/v meter, or a vacuum-tube voltmeter is used, the voltage reading obtained will be sufficient to indicate the source of the trouble. For example, if a voltage reading more negative than about -15 volts is obtained, there is probably no conduction through the Timing Resistor. This would indicate an open divider, R147-148, assuming the diode V152 to be good.

If the Miller circuit is hung up at the low end of the sawtooth, as indicated by a voltage reading of zero or a few volts negative, a check of the voltage at the plate of the Miller tube will offer a clue to the cause. If this voltage is quite high (about +300 volts), check the neon lamp B167 and the Runup CF tube V173. If the voltage at the plate of the Miller tube is zero or slightly negative, check for an open plate-load resistor R164, R165 or R166.

However, if the voltage at the plate of the Miller tube is near the quiescent level (about +45 volts) the trouble will generally lie ahead of the Miller tube. The result of the trouble is that the On-Off Diodes V152 cannot be gated off; they are conducting heavily and clamping the grid of the Miller tube near ground. If all of the tubes have been checked, then check for open plate and cathode resistors in the Sweep-Gating Multivibrator circuit, the Hold-Off circuit and the Runup CF circuit. Also check that the STABILITY control can vary the voltage at the grid of V125.

Improper Triggering

If the sweep cannot be triggered properly, the gating pulse from the Multivibrator is not turning the diodes V152 off and on properly. The start of the gating pulse, which turns the diodes off and starts the sweep, is initiated by the triggering pulse at the grid of V135A. The end of the gating pulse, which turns the diodes on and initiates the retrace, is controlled by the hold-off waveform at the grid of V135A. The Sweep-Gating Multivibrator can be eliminated as the cause of the trouble if the sweep can be turned off and on with the STABILITY control. The main component to check, in addition to the tubes, is the differentiating capacitor C131.

Nonlinear Sweep

A nonlinear sweep voltage will be generated if the current charging the Timing Capacitor C160 does not remain constant. If the nonlinearity occurs at all sweep rates a defective Miller tube will be the probable cause. If the nonlinearity occurs only at certain sweep rates a leaky timing Capacitor will be the probable cause but the Miller tube should not be overlooked. A defective bootstrap capacitor C165 can cause the sweep to be nonlinear at the faster sweep rates.

Insufficient Horizontal Deflection

If the horizontal trace starts at the left side of the graticule, but does not extend to the right side, the Hold-Off circuit is causing V135A to conduct too soon after the triggering pulse had forced it into cutoff. If the trace cannot

be expanded the full length of the graticule with the Swp. Length control R176, check the resistance values in the cathode circuit of V173.

TROUBLESHOOTING THE HORIZONTAL AMPLIFIER

No Spot or Trace Visible on CRT

To determine that the Horizontal Amplifier is in a state of dc unbalance, short the horizontal deflection plates together at the neck pins of the crt in the manner explained for troubleshooting the Vertical Amplifier. The horizontal deflection plates are marked RED (LEFT) and GREEN (RIGHT). The INTENSITY control should be set to mid-scale. If a spot appears when the horizontal deflection plates are shorted together (it may be necessary to adjust the Vertical POSITIONING control), the trouble lies in the Horizontal Amplifier.

CAUTION

Do not permit the spot to remain on the crt at this setting of the INTENSITY control. Either reduce intensity until the spot is just visible, or remove the short from the horizontal deflection plates.

The procedure for troubleshooting the Horizontal Amplifier to locate the defective stage, is similar to that explained for troubleshooting the Vertical Amplifier for unbalance. The shorting strap can be moved from the deflection plates back toward the Input Amplifier stage, until a point is reached where the trace does not appear. When the stage at fault is determined, check for defective tubes and components associated with the stage.

Insufficient or No Horizontal Deflection

If the gain of the Horizontal Amplifier decreases, the trace will not extend from the left to the right side of the graticule. In addition, the timing will no longer correspond to the calibrated value indicated by the TIME/CM switch. (This is to distinguish the condition of insufficient sweep produced by a malfunction in the Horizontal Amplifier from one produced in the Time-Base Generator, e.g., an improper adjustment of the Swp. Length control. In the latter case the trace will start at the left side of the graticule, for the normal setting of the HORIZONTAL POSITION control, and the timing will not be affected.)

If the change in gain is slight, as indicated by improper timing and a slightly decreased sweep, the amplifier can usually be recalibrated. Since the gain of the Horizontal Amplifier regulates the timing of the sweep, care must be taken to insure that the gain adjustments are accurately made. Be sure to refer to the Calibration Procedure if it is necessary to adjust the gain of the Horizontal Amplifier.

If the decrease in gain of the Horizontal Amplifier is more pronounced, or if there is no sweep at all (in which case only a spot will be visible on the horizontal axis), check for defective components which can affect the gain but not the dc balance. In addition to the tubes, such components would be the common cathode resistors and controls.

TROUBLESHOOTING THE LOW-VOLTAGE POWER SUPPLY

Proper operation of every circuit in your instrument depends on proper operation of the Power Supply. The regulated dc voltages must remain within their specified tolerances for the instrument to retain its calibration.

CAUTION

Exercise care in checking the power supply. Because of their high current capabilities and low impedance, the Low-Voltage supplies can produce more harmful shocks than the high-voltage supply in the CRT circuit.

Open Power Circuit (Dead Circuit)

If the pilot lamp and the fan do not come on when the power is turned on, check the source of power and the power cord connections. Check the fuse. If the fuse is blown replace it with one of the proper value and turn the instrument on again. If the new fuse blows immediately, check the power transformer for shorted primary or secondary windings. Also check for shorted rectifiers. If the new fuse does not blow until the time-delay relay has activated (a "click" can be heard), check for a shorted condition in the regulator circuits and the loading on the supply.

If the fuse is good, check for an open primary winding in the power transformer. If your instrument is wired for 234-volt operation, check for an open Thermal Cutout Switch; the resistance of this switch is about .1 Ω . (If your instrument is wired for 117-volt operation, the fan will come on even though the Thermal Cutout Switch may be open).

If both the fan and pilot light come on, the primary circuit of the power transformer is operating normally.

Incorrect Output Voltage

The voltage for each test point is silk-screened on the lip of the chassis adjacent to the ceramic strip on which the test points are located. Refer to Fig. 5-16 for a low-voltage check point location.

Each regulated bus is identified by a color-coded wire. The -150-volt bus is coded brown, green and brown on a black wire; the +100-volt bus is coded brown, black and brown on a white wire; the +225-volt bus is coded red, red and brown on a white wire; the +350-volt bus is coded orange, green and brown on a white wire; and the +500-volt bus is coded green, black and brown on a white wire.

If any of the supplies fail to regulate the first thing to check is the line voltage. The supplies are designed to regulate between 105 and 125 volts with the design center at 117 volts, or between 210 and 250 volts with the design center at 234 volts, rms, 50-60 cycle single phase ac.

When possible, check the resistance values between the outputs of the Low-Voltage Power supplies and ground.

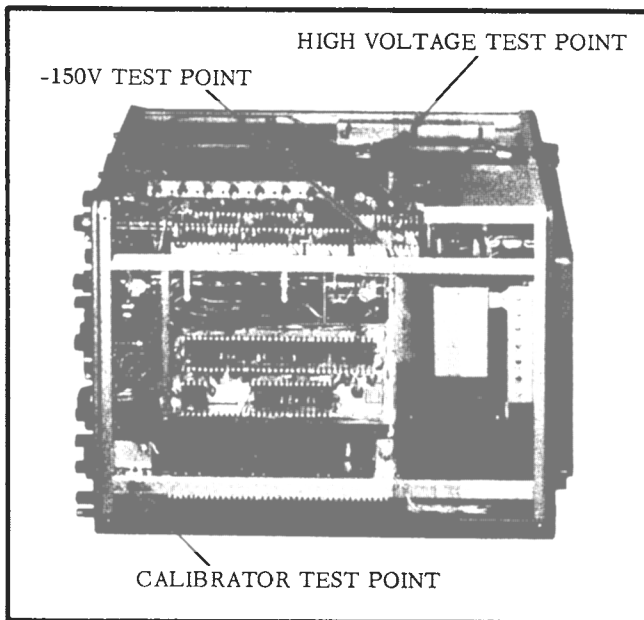

Fig. 5-16. Location of Power Supply and Calibrator test points.

If the resistance values between the regulated buses and ground check out, check the tubes (if this has not already been done). Then make sure that the line voltage is set near the design center for your instrument (117 or 234 v) and check the rms voltage across the secondary winding for each supply; the nominal value of each secondary voltage, when the line is set to the design center, is indicated on the circuit diagram. If the secondary voltages are all correct, check the operation of the bridge rectifiers. This can be done by measuring the rectified voltage at the input to each regulator. These values are also indicated on the circuit diagram. Then check for off-value resistors, especially in the dividers, and for open or leaky capacitors.

The material that follows may be used as a quick index for troubleshooting the regulator circuits.

If the output voltage is high with excessive ripple, check:

- a. For high line voltage.
- b. For open voltage-regulator tube.
- c. The amplifier tubes in the regulator circuit.
- d. For insufficient loading.

If the output voltage is high with normal ripple, check:

- a. For proper resistance value in the dividers refer to the schematic for your instrument to determine the location of the resistors involved. Since these are generally precision resistors ($\pm 1\%$ tolerance) the use of a good bridge is recommended in checking the value.

If the output is low with excessive ripple, check:

- a. For low line voltage.
- b. For shorted voltage-regulator tube.
- c. The series tubes in the regulator circuit.
- d. For excessive loading.

- e. Open or leaky filter capacitors.
- f. Defective rectifiers.

If the output is low with normal ripple, check:

- a. The resistance values in the dividers.
- b. The capacitors across the dividers.

NOTE

If any components in the -150 -volt supply are changed, or if the setting of the -150 Adj. control is changed, it will be necessary to recalibrate the instrument.

TROUBLESHOOTING THE CALIBRATOR

Asymmetrical Output

If the output square wave is not symmetrical (the positive portion has a duration different from that of the negative portion) the two tubes in the Multivibrator circuit are not being held cutoff for equal periods. This will normally be caused by a defective tube. If tube replacement does not correct the waveform the circuit components must be checked. The triode in the Multivibrator is held cutoff for an interval determined by the discharge of C871 and the pentode is held cutoff for an interval determined by the discharge of C874. A change in the value of either capacitor, or in the value of the resistor through which they discharge, could produce an asymmetrical waveform.

In addition, the time needed for these capacitors to discharge a given amount is affected by the potential toward which they discharge; this would be the voltage at the plate of the triode in the case of C874, and the voltage at the screen of the pentode in the case of C871. Since these voltages are affected by the value of R870 and R875, these resistors should be checked. The resistors in the plate circuit of the pentode should also be checked, since they will affect the plate-to-screen ratio of the pentode.

Incorrect Output Voltage

The amplitude of the output square wave is determined almost entirely by the resistance value in the divider in the cathode-follower stage. A quick check of the resistance values can be made by turning off the Calibrator and measuring the voltage at the Cal. Test Pt.; if this point does not measure exactly $+100$ volts the output voltages when the Calibrator is turned on will not be correct.

The Cal. Adj. control R879 will vary the voltage at the test point over about a 10-volt range. If this voltage cannot be set to exactly $+100$ volts, and if the tubes have been replaced, then one or more of the precision resistors in the divider have changed in value.

TROUBLESHOOTING THE CRT CIRCUIT

The intensity, focus, geometry and calibration of the crt display depend on proper operation of the high-voltage supplies in the CRT Circuit.

No Intensity

If the low-voltage power supply is operating normally, but no spot or trace is visible on the crt, the trouble could be a defective crt, a defect in the crt cathode circuit including the supply, or an unbalanced dc condition in either or both of the deflection amplifiers. In the latter case the dc unbalance is producing improper positioning voltages and the beam is being deflected off the screen.

To determine which circuit is at fault, turn the INTENSITY control full right (cw). If a flare is observed on the crt screen (it may be necessary to darken the room), one of the deflection amplifiers is probably at fault; the procedure for troubleshooting these circuits follows a bit later in this section. If no flare is observed with the INTENSITY control turned full right, the trouble will either be due to a defective crt or to an inoperative cathode supply circuit. The cathode supply can be checked by measuring the voltage at the H.V. Adj. Test Pt. In the majority of instruments the test point is located at the top left rear of the instrument. Fig. 5-16 shows the location of typical high-voltage test points. Refer to the schematic diagrams for your instrument to determine the correct voltage. If the voltage reading you obtain is in the vicinity of the correct voltage noted on the schematic, turn the instrument off, and measure the value of the 27K resistor attached to the test point (see Fig. 5-16). If this resistor is not open a defective crt is indicated.

If the voltage at the H.V. Adj. Test Pt. is zero or abnormally low replace the Oscillator tube and the Error-Signal Amplifier tube. If this does not restore operation the Oscillator circuit should be checked.

A quick check on the operation of the Oscillator circuit can be made by observing the heater glow in the 5642 rectifier tubes, located under the shield at the upper right rear of the instrument. These tubes are visible through the opening in the side of the shield. If no heater glow is visible the Oscillator circuit is inoperative. This could be due to an open high-voltage transformer, or to a defective component in the oscillator or error-signal amplifier circuits.

If heater glow is visible in the rectifier tubes, the Oscillator circuit is operating. If the heater glow appears to be dim, however, the output of the Oscillator may be insuf-

ficient for proper operation. A more accurate check on the Oscillator may be made by removing the shield covering the high-voltage transformer and measuring the bias at the grid of the oscillator tube. This can be measured at the junction of the 100 k resistor and the .01- μ fd capacitor. See the simplified schematic, Fig. 4-10 for normal circuit configuration in the high-voltage oscillator. The voltage at this point should measure about -6.5 volts.

CAUTION

Do not let your hand or body touch the chassis when making this check. Secondary reactions to an otherwise harmless shock might result in a painful injury.

If the Oscillator circuit is operating properly, but the voltage at the H.V. Adj. Test Pt. does not measure in the vicinity of that indicated on the schematic diagram for the instrument, the 5642 rectifier tube, V822, shown in the simplified schematic of Fig. 4-10, is most likely defective.

Abnormal Intensity

If a trace is visible on the crt, the relative intensity of the trace may be used to identify trouble in either the negative bias supply or the positive anode supply.

If the trace is excessively brilliant, and if the brilliancy does not change as the INTENSITY control is adjusted, check the negative bias supply including the lead to the first grid of the crt. Check for a defective rectifier tube V822, (shown in the simplified schematic diagram of Fig. 4-10), an open supply winding or filament winding, an open resistor including the INTENSITY control, or a shorted or leaky capacitor. If trouble is not found in any of these components, a defective crt is indicated.

If the intensity of the trace is extremely low, check for an inoperative positive supply. Also check the anode connection to the crt, including R836 and C836.

If the accelerating potentials appear to be too high, as evidenced by decreased deflection sensitivity, check the Error-Signal Amplifier circuit.

If a badly distorted trace or spot is visible on the crt, check the Geom. Adj. control and its connection to the neck pin on the crt, and the ASTIGMATISM control and its connection to the crt base socket. If the FOCUS control has no effect on the trace, check this control and its connection to the crt base socket.

NOTE

If any components in the Oscillator, Error-Signal Amplifier or cathode supply circuit are changed, or if the setting of the H.V. Adj. Control is changed it will be necessary to recalibrate the instrument.

CALIBRATION PROCEDURE

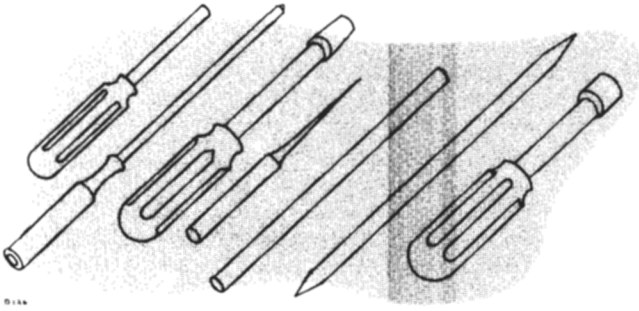

The Type 545A Oscilloscope is a stable instrument and should not require frequent calibration. However, it will be necessary to calibrate certain parts of the instrument when tubes or components are changed, and periodic calibration is desirable from the standpoint of preventive maintenance.

In the instructions that follow, the steps are arranged in the proper sequence for full calibration. Each numbered step contains the information necessary to make one adjustment. If a complete calibration is not necessary, you may perform individual steps, PROVIDING that the steps performed do not affect other adjustments. It is most important that you are fully aware of the interaction of adjustments. Generally speaking, the interaction of controls will be apparent in the schematic diagrams. If you are in doubt, check the calibration of the entire section on which you are working.

If you make any adjustments on the power supplies, you will have to check the calibration of the entire instrument. In particular the sweep rates and vertical deflection factors must be checked.

EQUIPMENT REQUIRED

The following equipment is necessary for a complete calibration of the Type 545A Oscilloscope.

(1.) A DC voltmeter having a sensitivity of at least 5000 Ω/v and calibrated for an accuracy of at least 1% at 100, 150, 225, 350 and 500 volts, and for an accuracy of at least 3% at 1350 volts. Portable multimeters should be regularly checked against an accurate standard and corrected readings noted, where necessary, at the above listed voltages.

BE SURE YOUR METER IS ACCURATE

(2.) An accurate rms-reading ac voltmeter, having a range of 0-150 volts. (0-250 or 0-300 for 234 v. operation).

(3.) Variable auto-transformer (e.g. Powerstat or Variac) having a rating of at least 6.25 amperes.

(4.) Time-Mark Generator, Tektronix Type 180, 180A or equivalent, having markers at 1 μsec , 10 μsec , 50 μsec , 100 μsec , 1 msec, 5 msec, 10 msec, 100 msec, 1 sec, and 5 sec and sine-wave outputs of 10 mc and 50 mc, all having an accuracy of at least 1%.

(5.) Square-Wave Generator, Tektronix Type 107 or equivalent, having a risetime of no more than 7 nano-seconds, and a frequency of approximately 500 kc. The top of the square-wave must be free of overshoot and wrinkles. A Tektronix Type P Unit may be used in place of the Type 107. A Type P52 Coaxial Cable and a Type B52R Terminating Resistor is required with the Type 107.

(6.) Tektronix Type K or Type L Plug-In Unit. (If delay-line adjustment is not required, other Tektronix Plug-In Units may be substituted.)

(7.) Low-Capacitance Recalibration Tools: Tektronix part numbers 003-000, 003-007 and 003-301. (See Recalibration Tools in Accessories Section of Operator's Manual and Fig. 6-11).

(8.) Tektronix Type P6000 or P410A Probe.

(9.) Test Oscilloscope, Tektronix Type 316 or equivalent, providing triggered sweeps and a bandpass of at least dc to 10 mc.

(10.) Gain Set Adapter, Tektronix Type EP53A.

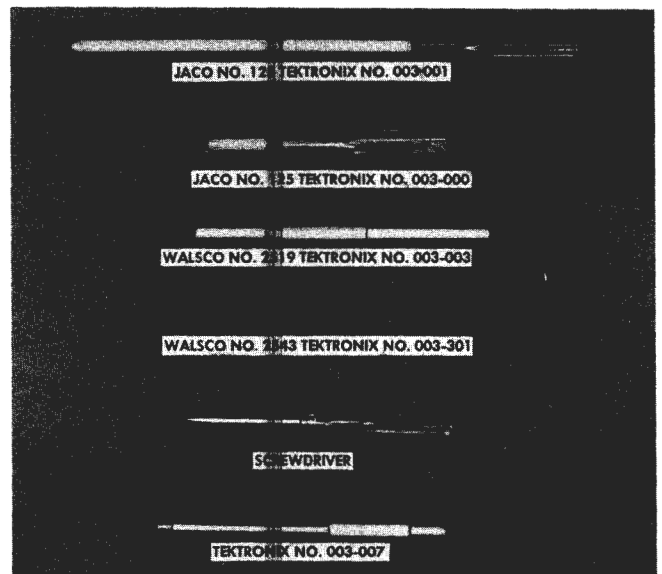

Fig. 6-1. Suggested Calibration Tools.

Calibration Procedure — Type 545A

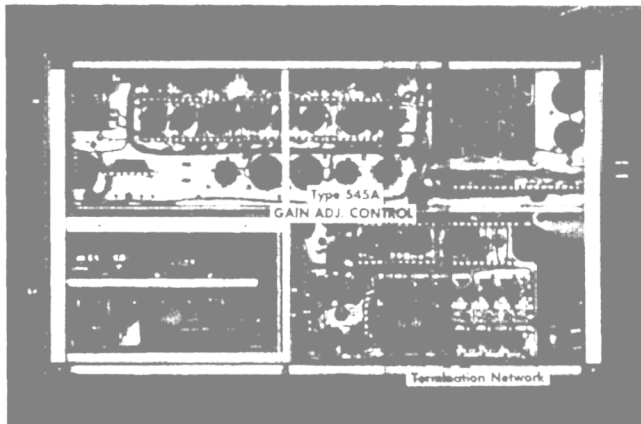

Fig. 6-2. Bottom view of the Type 545A Oscilloscope showing the location of the GAIN ADJ. control.

PRELIMINARY

Remove the side covers and bottom plate from the instrument to be calibrated and install the Type K or Type L Unit.

Set the front-panel controls as follows:

INTENSITY	full left
HORIZONTAL DISPLAY	A

TRIGGERING MODE (A and B)	AC
TRIGGER SLOPE (A and B)	+INT.
STABILITY (A and B)	full left, but not PRESET
TIME/CM (A and B)	.5 MILLISEC
VARIABLE	CALIBRATED (full right)
CALIBRATOR	OFF

Plug-In Unit

AC/DC	DC
VOLTS/CM	.05
VARIABLE	CALIBRATED (full right)

NOTE

Settings for all controls not listed above are not pertinent to this part of the procedure and the controls may be left in any position.

Check the rear panel of the instrument to be sure the metal strap between EXTERNAL CRT CATHODE and GROUND binding posts is in place, and that the CRT SELECTOR switch is away from the DUAL-TRACE CHOPPED BLANKING position. Connect the instrument and the ac meter to the autotransformer output and turn on all equipment. Adjust the autotransformer to the design-center voltage for which your instrument is wired (117 or 234 v.) and allow at least 5 minutes warmup before making any adjustments.

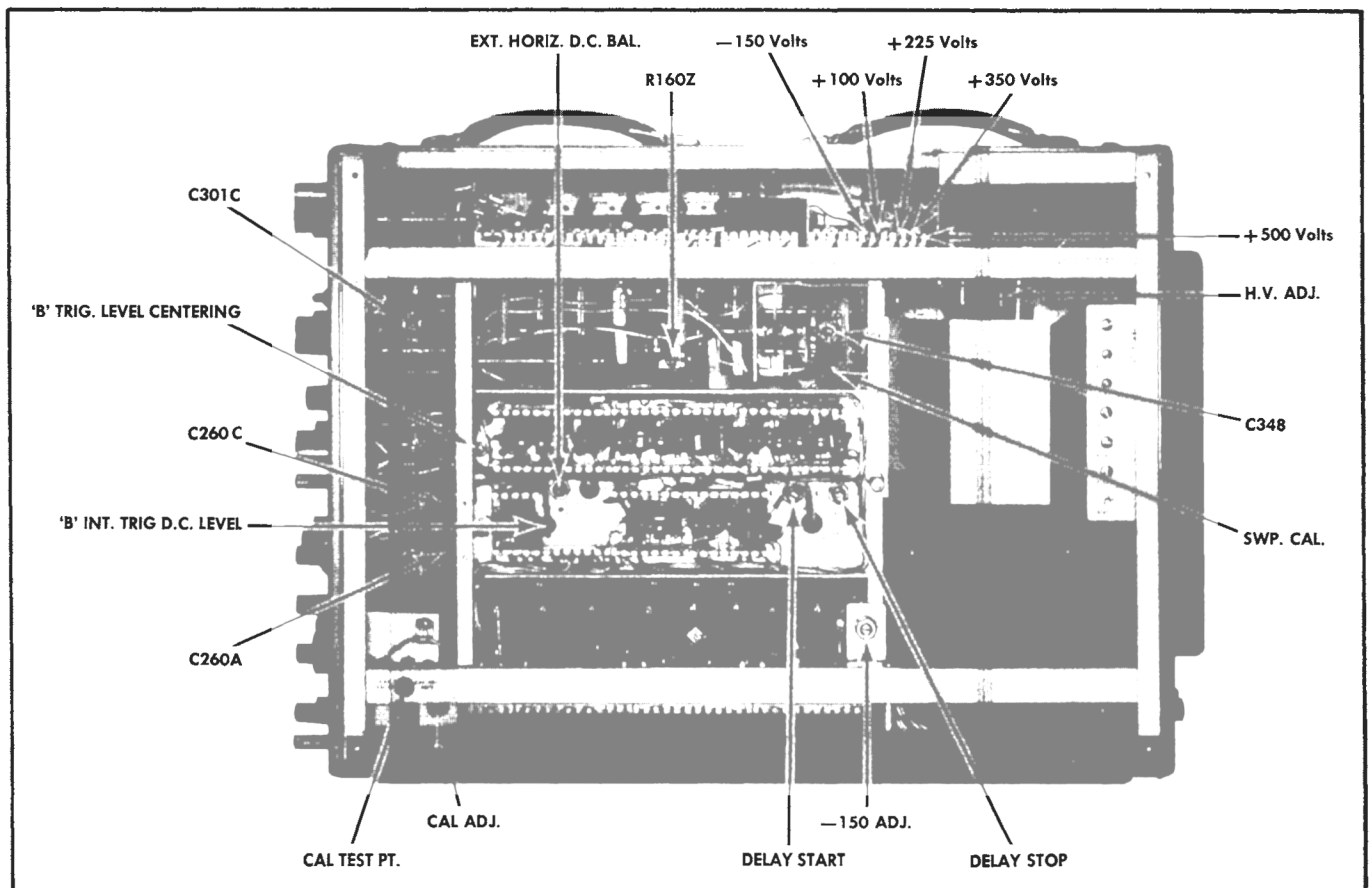

Fig. 6-3. Right-Side View of the Oscilloscope showing the internal controls locations.

PROCEDURE

1. Low-Voltage Power Supplies

Measure the output voltage of the -150 v , $+100\text{ v}$, $+225\text{ v}$, $+350\text{ v}$ and $+500\text{ v}$ supplies at the points indicated on the right side view, Fig. 6-3. Be sure your meter is accurate (see Equipment Required, Fig. 6-1). The output voltage of the -150 v supply must be between -147 v and -153 v , and the other regulated supplies must be within 2% of their rated values. You should be able to set the -150 V Adj. control (see Right Side View, Fig. 6-3) so that all of these voltages are within the specified tolerance. Bear in mind that the calibration of the entire instrument is affected by changes in the power supply voltages. Don't adjust the -150 v unless one or more of the supplies is actually out of tolerance.

To check the above supplies for proper regulation, vary the autotransformer voltage between 105 v and 125 v (or from 210 v to 250 v if the power transformer is connected for 234 v operation). All of the regulated voltages should remain essentially constant.

The ripple present on any of the regulated supplies, as measured with a test scope at the voltage check points, will be well under 10 mv. , with AMPLITUDE CALIBRATOR-OFF, and neither sweep operating.

2. AMPLITUDE-CALIBRATOR Adjustment

The Cal. Adj. control should be set to provide a dc output of 100 volts when the AMPLITUDE CALIBRATOR switch is in the OFF position. Under these conditions, the calibrator output will be within 3% of the front-panel readings.

To make this adjustment connect the voltmeter between the Cal. Test Pt. jack and ground (see Right Side View, Fig. 6-3), turn the AMPLITUDE CALIBRATOR switch to the OFF position, and adjust the Cal. Adj. control for a reading of exactly 100 volts. To assure suitable symmetry of the calibrator waveform, the reading at this point should not be less than 45 v nor more than 55 v when the calibrator is turned on (to any of the output voltage settings). Readings outside this range are generally caused by unbalanced multivibrator tubes (V875 or V885A).

3. High-Voltage Power Supply Adjustment

This adjustment determines the total accelerating potential on the crt, and thus affects the deflection sensitivity.

Connect the voltmeter between ground and the high-voltage check point (see Top-View, Fig. 6-4), and set the H.V. Adj. (see Right Side View, Fig. 6-3) for a meter reading of exactly -1350 volts . If your meter has a full scale reading of 1200 v , you can connect the positive meter lead to the -150 v supply, at any convenient point, and set the H.V. Adj. for a meter reading of -1200 v .

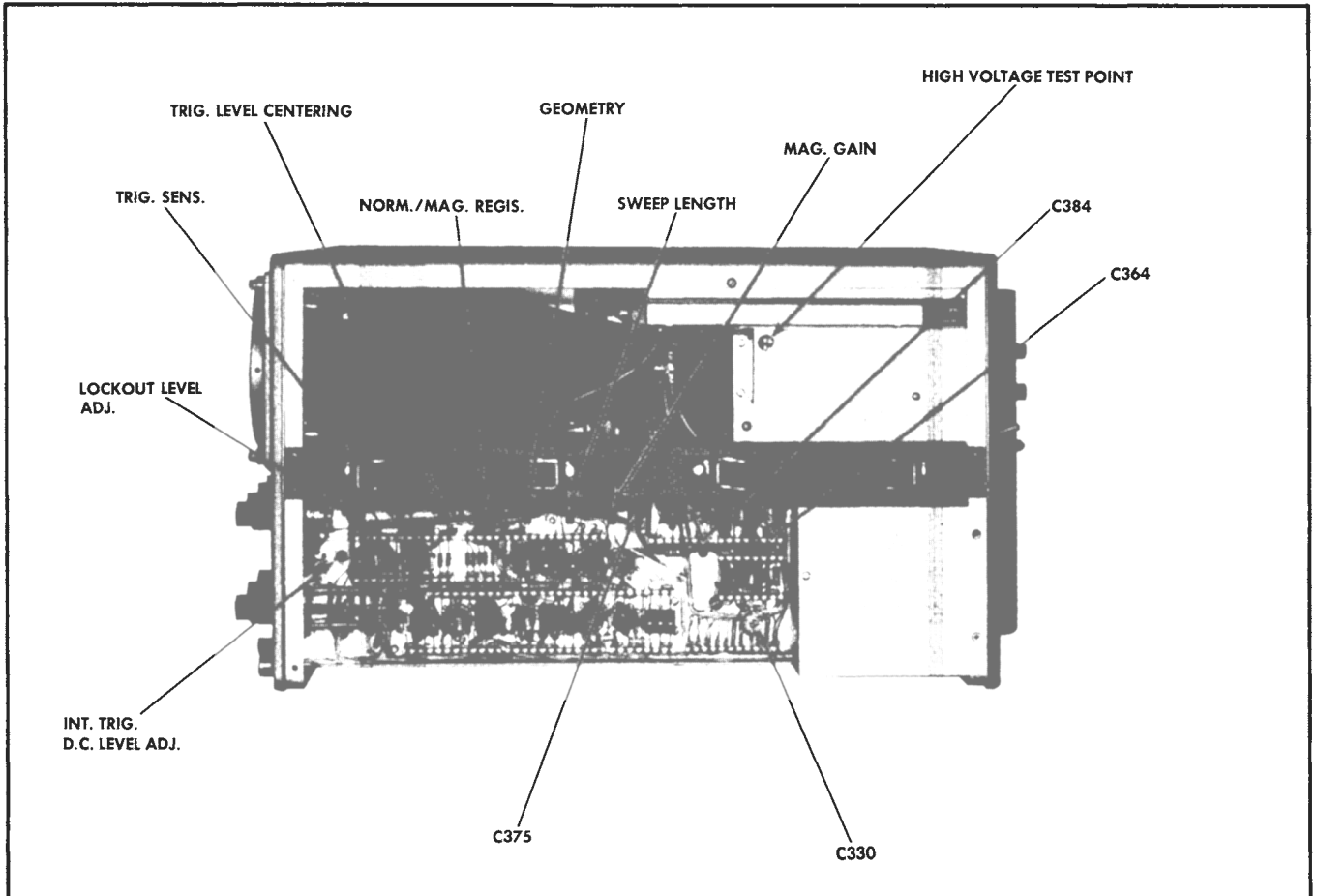

Fig. 6-4. Top View of the Oscilloscope showing locations of internal controls.

4. CRT Alignment

If the crt has been replaced, or if, due to considerable handling, the trace does not align with the graticule, you should make this adjustment before proceeding with the calibration.

With the crt base clamp loose (see Left Side View, Fig. 6-5), and no vertical signal applied, free run TIME BASE A, by turning the STABILITY control full right. Position the

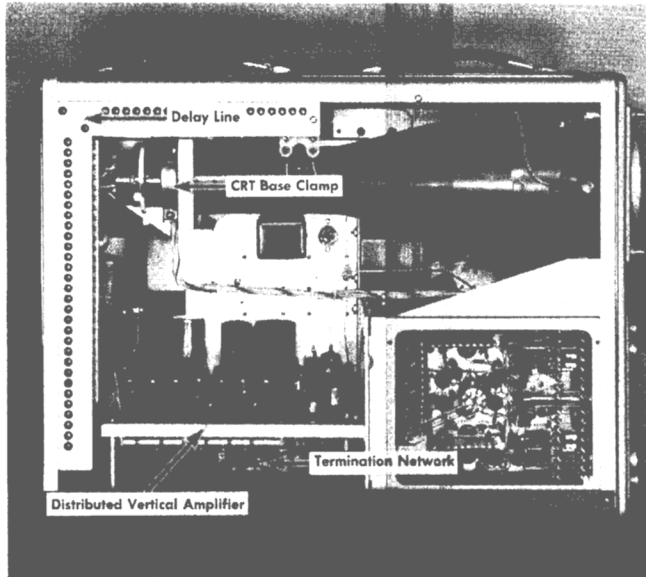

Fig. 6-5. Left-Side View of the Type 545A Oscilloscope showing locations of major components.

trace directly behind the center graticule line. If the trace and the graticule line do not coincide over the width of the graticule, rotate the crt until they are properly aligned.

After aligning, push the crt forward until it rests snugly against the graticule, and tighten the crt base clamp. Re-check the alignment of the trace after tightening the clamp to be sure the crt didn't rotate while the clamp was being tightened.

5. CRT Geometry

The geometry of the crt display is adjusted by means of the GEOMETRY control. To achieve optimum linearity,

vertical lines are displayed on the crt and the GEOMETRY control is adjusted for minimum curvature of the lines. Non-linearity is most noticeable at the edges of the graticule.

Set front panel controls as follows (use TIME BASE A):

HORIZONTAL DISPLAY	A
TRIGGERING MODE	AC
TRIGGER SLOPE	+INT
TIME/CM	.5 MILLISEC
VARIABLE	CALIBRATED (full right)
VOLTS/CM (plug-in)	.2

Connect 500 μ sec markers from the Type 180 or 180A to the INPUT connector and position the base line of the timing comb below the bottom of the crt face so it is not visible. Adjust the GEOMETRY control (see Top View, Fig. 6-4) for straight vertical lines running parallel to the left and right edges of the graticule (see Fig. 6-6).

NOTE

The amplitude calibrator may be used for this step, but due to the low intensity of the vertical lines, the adjustment is somewhat more difficult.

6. 'A' Trigger Level Centering and Trigger Sensitivity

Reset front-panel controls as follows.

STABILITY	full right (cw)
TRIGGERING LEVEL	0
TRIGGERING MODE	AC SLOW (AC)
TRIGGER SLOPE	+INT.
TIME/CM	.5 mSEC
VARIABLE	CALIBRATED
HORIZONTAL DISPLAY	A
CALIBRATOR	10 MILLIVOLTS

PLUG-IN UNIT

AC/DC	DC
VOLTS/CM	.05
VARIABLE	CALIBRATED

Connect a test lead from the CAL. OUT connector to the INPUT connector on the plug-in unit; this should result in a free-running trace having an amplitude of about 2 millimeters (1 minor division). Center the trace vertically on the

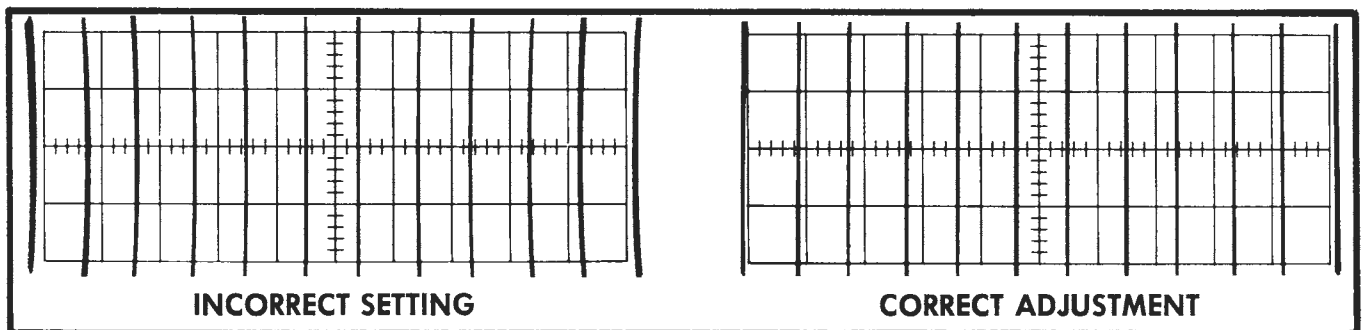

Fig. 6-6. Waveforms obtained while adjusting the geometry of a Type 545A Oscilloscope.

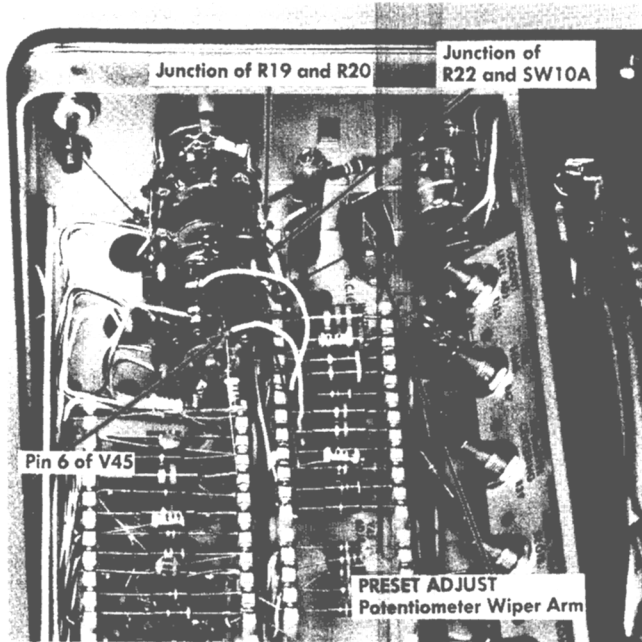

Fig. 6-7. Time Base A Triggering Circuit test points.

screen and adjust the INTENSITY, FOCUS and ASTIGMATISM controls for best definition. Then ground the junction of R19 and R20 with a short clip lead. This junction is located on top of the Trigger switch (see Fig. 6-7).

Preset the Trigger Sensitivity control full left (ccw) and the Trigger Level Centering control full right (cw). Turn the STABILITY control left until the trace just disappears from the crt screen, then two or three degrees further left.

Turn the Trigger Level Centering control to the left until the display reappears on the screen. If the display does not appear, turn the Trigger Sensitivity control to the right a few degrees, and repeat the adjustment of the Trigger Level Centering control until the display reappears. Reduce the amplitude of the signal by turning the VARIABLE gain control on the plug-in unit slowly toward the full left position, at the same time continuing the adjustment of the Trigger Level Centering and Trigger Sensitivity controls to keep the trace on the screen. Then switch the TRIGGER SLOPE control to —INT. and +INT.; it may be necessary to turn the Trigger Level Centering control back to the right a bit to obtain a stable display. Then while switching back and forth between +INT. and —INT., slightly readjust both the Trigger Level Centering and Trigger Sensitivity controls for stable triggering in both positions.

7. Internal Triggering DC Level

Increase the setting of the CALIBRATOR to 20 millivolts. Return the VARIABLE gain to the CALIBRATED position, center the display vertically, and turn the TRIGGERING MODE switch to the DC position. Then, while switching the TRIGGER SLOPE control back and forth between +INT. and —INT., adjust the Int. Trig. DC Level Adj. control for stable triggering in both positions. It may be necessary to slightly adjust the VERTICAL POSITION control to obtain stable triggering.

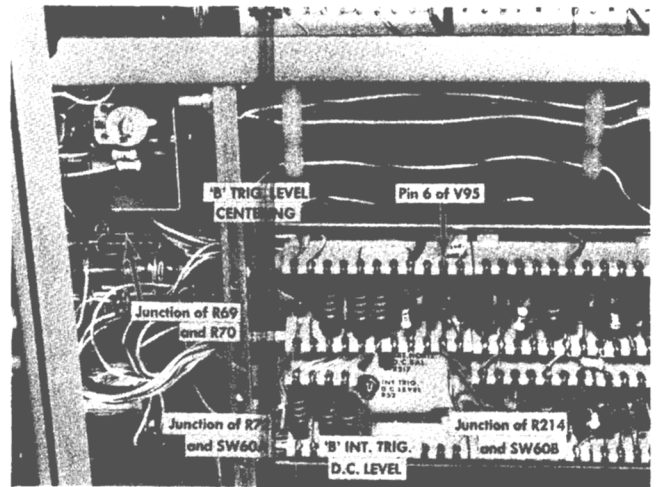

Fig. 6-8. Time Base B Triggering Circuit Test points.

8. 'A' Trigger Level

Remove the jumper and turn the TRIGGERING LEVEL control until the wave-form is triggered at the same point as that observed when the shorting lead was connected. The white dot on the TRIGGERING LEVEL knob should now point at 0. If it doesn't, loosen the knob and move it to this position.

9. 'A' Preset Adjust

Place the 'A' TRIGGERING MODE switch at AUTO. and the TRIGGER SLOPE switch at +LINE. Connect the dc voltmeter between the PRESET ADJUST potentiometer wiper arm (see Fig. 6-7) and ground and rotate the potentiometer full left. Now, rotate the control slowly to the right until a trace first appears and note the meter reading at this point. Next, continue to rotate this control until the trace brightens and again note the meter reading. Finally, set the PRESET ADJUST control to obtain a meter reading midway between the two previously noted meter readings.

10. 'B' Trigger Level Centering

It will be the controls for TIME BASE 'B' that you will set up now.

Set up the oscilloscope as indicated in Step 6, except for the HORIZONTAL DISPLAY switch. It will be set to 'B' position. Then ground the junction of R69 and R29 with a short clip lead. This junction is located on top of the Trigger switch (see Fig. 6-8).

Preset the Trigger Level Centering control full right (cw). Turn the STABILITY control left until the trace just disappears from the crt screen, then two or three degrees further left.

Turn the Trigger Level Centering control to the left until the display reappears on the screen. Reduce the amplitude of the signal by turning the VARIABLE gain control on the plug-in unit slowly toward the full left position, at the same time continuing the adjustment of the Trigger Level

Calibration Procedure — Type 545A

Centering. Then while switching back and forth between +INT. and -INT., slightly readjust the Trigger Level Centering control for stable triggering in both positions.

11. 'B' Internal Triggering DC Level

Increase the setting of CALIBRATOR to 20 millivolts. Return the VARIABLE gain control to the CALIBRATED POSITION, center the display vertically, and turn the TRIGGERING MODE switch to the DC position. Then, while switching the TRIGGER SLOPE control back and forth between +INT. and -INT., adjust the Int. Trig. DC Level Adj. control for stable triggering in both positions. It may be necessary to slightly adjust the VERTICAL POSITION control to obtain stable triggering.

12. 'B' Triggering Level

Remove jumper and turn the TRIGGERING LEVEL control until the waveform is triggered at the same point as that observed when the shorting lead was connected. The white dot on the TRIGGERING LEVEL knob should now point at 0. If it doesn't, loosen the knob and move it to this position.

13. 'B' Preset Adjust

Place the 'B' TRIGGERING MODE switch at AUTO and the 'B' TRIGGER SLOPE switch at +LINE. Connect the dc voltmeter between ground and the junction of R214 and SW60B (see Fig. 6-8), and rotate the 'B' PRESET ADJUST control full left. Now, rotate the control slowly to the right until a trace first appears, and note the meter reading at this point. Next continue to rotate this control until the trace brightens, and again note the meter reading. Finally, set the PRESET ADJUST control to obtain a meter reading midway between the two previously noted readings.

14. Adjust 5X Magnifier Gain

Set controls as follows:

HORIZONTAL DISPLAY	'B'
TRIGGERING MODE (B)	AC
TRIGGER SLOPE (B)	+INT
TIME/CM (B)	1 MILLISEC
5X MAGNIFIER	ON
VOLTS/CM (Plug-In)	2

Connect 1 millisecond and 100 microsecond markers from the Type 180A to the vertical input and adjust the 'B' triggering for a stable display. If necessary adjust Mag. Gain (see Top View Fig. 6-4) to display 1 large marker every 5 cm, and 2 small markers every cm. Position the display horizontally to observe linearity on both ends. Check that the neon lamp lights when MAGNIFIER is switched on.

15. Adjust Sweep Magnifier Registration

With the MAGNIFIER ON, position the display so that the first time marker is directly behind the center graticule line. Turn the MAGNIFIER OFF and adjust Norm./Mag. Regis. (see Top View Fig. 6-4) so that the first time marker again falls directly behind the center graticule line.

16. Adjust External Horizontal DC Balance

Connect a jumper from the 'A' SAWTOOTH to the vertical INPUT, switch the HORIZONTAL DISPLAY to EXT. X1 and turn 'A' STABILITY full right. Turn the HORIZONTAL POSITION control to the left to position a vertical trace to the left vertical graticule line. Now, adjust the Ext. Horiz. DC Bal. (see Right Side View, Fig. 6-3) control for no horizontal shift of the trace while turning the horizontal VARIABLE 10-1 front-panel control.

17. Check EXT. HORIZ. INPUT Deflection Factor

With conditions as in Step 16 above, connect a jumper from CAL. OUT to HORIZ. INPUT, set CALIBRATOR for .2 volt and turn VARIABLE 10-1 control full right. At least one centimeter of horizontal deflection must be observed between the two vertical lines. Increase the CALIBRATOR to 2 VOLTS and adjust VARIABLE 10-1 for exactly 10 cm of horizontal deflection between the vertical lines. Now switch HORIZONTAL DISPLAY to EXT. X10. Horizontal deflection should now be 1 centimeter. (Attenuator accuracy $\pm 2\%$).

18. Adjust External Horizontal Input Compensation

Connect a jumper from 'A' SAWTOOTH to the vertical INPUT. Feed .5 VOLT from CAL. OUT. to both HORIZ. INPUT and 'A' TRIGGER INPUT. Set the controls as follows:

HORIZONTAL DISPLAY	EXT. X1
TRIGGER SLOPE (A)	-EXT.
TIME/CM	1 MILLISEC
VOLTS/CM (Plug-In)	10

Adjust 'A' STABILITY and TRIGGERING LEVEL controls for a stable square-wave, displayed vertically. Adjust C330 (see Top View, Fig. 6-4) for optimum square wave response. Now switch the HORIZONTAL DISPLAY to EXT. X10, increase CALIBRATOR signal to 5 VOLTS, and adjust C301C (see Right Side View, Fig. 6-3) for optimum flattop.

19. Adjust Sweep Calibration

Set controls as follows:

HORIZONTAL DISPLAY	B
TIME/CM (B)	1 MILLISEC
TRIGGERING MODE	AC
TRIGGER SLOPE	+INT
5X MAGNIFIER	OFF
VOLTS/CM (Plug-In)	2

Connect 1 millisecond markers from the Type 180A to the Vertical INPUT and adjust 'B' triggering for a stable display. Adjust Sweep Cal (see Right Side View, Fig. 6-3) for 1 time-marker per centimeter.

NOTE

Any non-linearity present in the sweep will always be in the first and last centimeter. Consequently all timing adjustments should be made from the 1 cm line to the 9 cm line in the graticule.

20. Adjust Time Base A to Time Base B

Switch HORIZONTAL DISPLAY to A, set TIME/CM to 1 MILLISEC, VARIABLE to CALIBRATED, and adjust 'A' triggering for a stable display. Adjust R160Z (see Right Side View, Fig. 6-3) for the same timing as that obtained for the 'B' sweep in Step 19 above, $\pm 5\%$.

21. Adjust Time Base A Sweep Length

With controls as in Step 20 above, adjust the Sweep Length control (see Top View, Fig. 6-4) for a sweep length of 10.5 centimeters.

22. Check Time Base B Sweep Rates

Starting with conditions as in Step 19 above, Check TIME BASE B sweep rates according to the following table:

TIME BASE B	TYPE 180A	Markers displayed
1 MILLISEC	1 MILLISECOND	1/cm
2 MILLISEC	1 MILLISECOND	2/cm
5 MILLISEC	5 MILLISECOND	1/cm
10 MILLISEC	10 MILLISECOND	1/cm
20 MILLISEC	10 MILLISECOND	2/cm
50 MILLISEC	50 MILLISECOND	1/cm
.1 SEC	100 MILLISECOND	1/cm
.2 SEC	100 MILLISECOND	2/cm
.5 SEC	500 MILLISECOND	1/cm
1 SEC	1 SECOND	1/cm

23. Check Time Base A Sweep Rates

Starting with conditions as in Step 20 above, check TIME BASE A sweep rates according to the following table:

TIME BASE A	TYPE 180A	Markers displayed
1 MILLISEC	1 MILLISECOND	1/cm
2 MILLISEC	1 MILLISECOND	2/cm
5 MILLISEC	5 MILLISECOND	1/cm
10 MILLISEC	10 MILLISECOND	1/cm
20 MILLISEC	10 MILLISECOND	2/cm
50 MILLISEC	50 MILLISECOND	1/cm
.1 SECOND	100 MILLISECOND	1/cm
.2 SECOND	100 MILLISECOND	2/cm
.5 SECOND	500 MILLISECOND	1/cm
1 SECOND	1 SECOND	1/cm
2 SECOND	1 SECOND	2/cm
5 SECOND	5 SECOND	1/cm

24. Check Time-Base A—Variable Time/CM Control and Uncalibrated Neon.

The VARIABLE control provides for a complete range of control between the calibrated TIME/CM steps. To check

operation of this control, set TIME/CM to 1 MILLISEC—CALIBRATED, connect 5 MILLISECOND markers from the Type 180A to the VERTICAL INPUT and trigger the oscilloscope for a stable display consisting of 1 marker for each 5 cm. Next, turn the VARIABLE control full left. The display should now consist of markers every 2 cm or less. Check to see that the UNCALIBRATED neon indicator lamp is lit in all positions of the VARIABLE control except when switched to the CALIBRATED position.

25. Adjust Time Base A Sweep rates, 50 $\mu\text{sec/cm}$ to .02 $\mu\text{sec/cm}$.

Set TIME BASE A TIME/CM to .1 MILLISEC, apply 10 MICROSECOND markers from the Type 180A to the Vertical INPUT, and adjust the triggering for a stable display. Turn the 5X MAGNIFIER to ON and horizontally position the trace so that the first time marker is aligned with the center graticule line. Then switch the TIME/CM switch to 50 μSEC and check for horizontal shift of the first marker. If shift occurs, adjust C330 (see Top View, Fig. 6-4) until the first marker of both the .1 MILLISEC and 50 MICROSEC positions occur at the same point.

Turn the 5X MAGNIFIER to OFF, TIME BASE A TIME/CM to 10 μSEC and proceed with the following adjustments:

TIME/CM	TYPE 180A	Adjustments	Observe
10 μSEC	10 MICROSECOND	C160E	1 marker/cm.
1 μSEC	1 MICROSECOND	C160C	1 marker/cm.
.5 μSEC	1 MICROSECOND	C160A	1 marker/2 cm. Position 2nd marker to 2nd line on graticule
.1 μSEC	10 MC	†C375 for linearity and C348 for time	1 cycle/cm
2 μSEC	1 MICROSECOND	Check timing range	2 markers/cm.
5 μSEC	5 MICROSECOND	Check timing range	1 marker/cm.
.1 μSEC X5	50 MC*	C364 and C384 (See Fig. 6-4)	1 cycle/cm.

† C375 only affects the first part of the display. There is considerable reaction between C348 and both C160A and C160C. The adjustments of C348 and C160A should be repeated back and forth several times to obtain optimum linearity with correct timing, after which C160C should be readjusted if necessary. Timing adjustments should be made, as usual, between the first and ninth centimeter lines of the graticule.

* Couple 50 MC from Type 180A through a small capacitor (100 μf) directly to one of the vertical plates of the crt. C364 and C384 should be set as nearly at the same capacity as possible. It may be necessary to slightly readjust C375 to obtain best possible linearity.

26. Check 'B' Sweep Length

Place the HORIZONTAL DISPLAY switch at B, the 'B' TIME/CM switch at .5 MILLISEC, and adjust for a free running sweep. Rotate the LENGTH control and check that the sweep length changes between approximately 3.5 and 10.5 centimeters. If the sweep length range is incorrect, substitute resistance values for R277 and R278 which will allow the proper range. R277 is normally between 12 k and 18 k; R278 is usually between 47 k and 68 k.

27. Set Delay Start and Delay Stop Adjustments

Set the HORIZONTAL DISPLAY switch at 'B' INTENSIFIED BY 'A'. Apply 500 μ second markers from the time-mark generator to the oscilloscope vertical input. Set the 'A' TIME/CM switch at 50 μ SEC and the 'B' TIME/CM switch at .5 MILLISEC. Adjust the 'B' triggering controls for a stable display. Rotate the 'A' STABILITY control fully clockwise. A portion of the display will be brightened. Set the DELAY-TIME MULTIPLIER control at 1.00. Adjust the Delay Start (see Right Side View, Fig. 6-3) control until the brightened portion starts at the first time mark (one centimeter from the start of the trace). Set the DELAY-TIME MULTIPLIER control at 9.00 and adjust the DELAY STOP (see Right Side View, Fig. 6-3) control until the brightened portion starts at the ninth time mark (nine centimeters from the start of the trace). Repeat the Delay Start and Delay Stop adjustments until a satisfactory setting is obtained for both controls. Set the DELAY-TIME MULTIPLIER control at 1.00 and place the HORIZONTAL DISPLAY switch at 'A' DEL'D BY 'B'. Adjust the Delay Start control so that the leading edge of the time mark is at the start of the trace. Set the DELAY-TIME MULTIPLIER control at 9.00 and adjust the Delay Stop control until the leading edge of the time mark is at the start of the trace.

28. Adjust Time Base B Sweep Rates

Place the HORIZONTAL DISPLAY switch at 'B' INTENSIFIED BY 'A'. Set the 'A' TIME/CM switch at 5 μ SEC and the 'B' TIME/CM switch at 50 μ SEC. Connect 50 μ second time markers to the oscilloscope vertical input and adjust the 'B' triggering controls for a stable display. Rotate the 'A' STABILITY control fully clockwise. Adjust the DELAY-TIME MULTIPLIER control to place the start of the brightened portion of the trace at the first marker (one centimeter from the start of the trace). Place the HORIZONTAL DISPLAY switch at 'A' DEL'D BY 'B' and adjust the DELAY-TIME MULTIPLIER control so that the leading edge of the time marker is at the start of the trace. Record the DELAY-TIME MULTIPLIER control setting. Adjust the DELAY-TIME MULTIPLIER control for a setting 8.00 higher than the setting recorded. Adjust C260C (see Right Side View, Fig. 6-3) until the leading edge of the ninth time marker is at the start of the trace.

Repeat the procedure outlined in the previous paragraph with the 'A' TIME/CM switch at .5 μ SEC, the 'B' TIME/CM switch at 5 μ SEC, and 5 μ second markers connected to the oscilloscope. The adjustment should be made with C260A (see Right Side View, Fig. 6-3).

29. Set Lockout Level Adjust

Set the HORIZONTAL DISPLAY switch at 'A' DEL'D BY 'B' the 'B' STABILITY control fully clockwise, and the 'A' TIME/CM switch at .1 MILLISEC. Slowly adjust the 'A' STABILITY control until the sweep first appears. Connect the test oscilloscope through a 10X probe to pin 3 of V133 using dc coupling. Adjust the test oscilloscope so that the displayed waveform has a vertical amplitude of four divisions. Adjust the Lockout Level Adj. control (see Top View, Fig. 6-4) until the square-wave portion of the displayed waveform is 2.4 divisions in amplitude. During adjustments, the 'A' STABILITY control should be checked frequently to be sure that it is set where the sweep just runs. At the completion of the adjustment, the square wave portion should be 2.4 centimeters in amplitude, the sawtooth portion should be 1.6 centimeters in amplitude.

30. Set Vertical Gain

Connect the EP53A Gain Set Adapter between the oscilloscope and plug-in unit. Connect a jumper from the CAL. OUT connector to the connector on the gain set adapter. Place the AMPLITUDE CALIBRATOR switch in the .2 VOLTS position and adjust the oscilloscope for a stable display. Set the Gain Adj. (see Figure 6-2) control for exactly 2 centimeters of vertical deflection.

31. Adjust Delay Line and High Frequency Compensations

Delay Line adjustments are probably the most difficult adjustments to make. This is due to interaction between the large number of controls. The adjustments can be made properly with a minimum of difficulty if the proper procedure is followed and if care is used in making the adjustments. In general, it is not necessary to completely readjust the delay line. Rather it is a case of occasionally touching up the line for best results. Before attempting to adjust the line, briefly run through this procedure to establish the basic concepts in your mind. This will make the actual adjustments considerably easier. Be sure that the line requires adjustment before attempting to adjust it.

In general the procedure for adjusting the delay line and high frequency controls involves application of a fast rising pulse or square wave to the vertical amplifier. The delay line is then adjusted for minimum distortion of the pulse or square wave displayed on the screen. In particular, the delay line and amplifier high frequency controls are adjusted for three characteristics of the displayed waveform: fastest possible risetime without overshoot, minimum irregularities on the top of the pulse, and minimum slope of the top of the waveform.

Displaying the Test Signal

To determine the extent of misadjustment of the delay line in your instrument, you will need to closely examine a displayed fast rising pulse or square wave. The waveform used to make this examination should have a risetime of no more than 7 nanoseconds. A Tektronix Type 107 Square-Wave Generator or a Tektronix Type P Plug-In Unit is recommended.

If a Type 107 Square-Wave Generator is used, the frequency control should be set to obtain approximately 400 kc square waves. The output of the generator should be connected through a 52 ohm coaxial cable and termination resistor to the input of either a Type K or a Type L Plug-In Unit. The termination resistor should be connected at the input to the plug-in unit.

When a Type P Plug-In Unit is used, it is only necessary to insert the unit into the plug-in compartment of the oscilloscope. The pulse frequency of the P Unit is fixed.

If it is necessary to use a signal generator other than a Type 107 or Type P, you must check the output waveform from the generator for suitability. Obviously a waveform which is distorted in any manner is not suitable for adjusting the delay line of an oscilloscope. A good check on the suitability of your test equipment is to display the output waveform on another Tektronix oscilloscope with a delay line known to be correctly adjusted.

When the input signal has been connected, adjust the oscilloscope triggering controls for a stable display using Time Base A. Rotate the TIME/CM control to .1 μ SEC and adjust the oscilloscope and signal source for approximately 3 centimeters of vertical deflection.

With the oscilloscope display, it is possible to check the delay line and amplifier adjustments for proper setting. There are three general characteristics which you will have to appraise, and to do this, you will need to use three different sweep rates. The first characteristic to look for is the level of the display; the second is the amount of bumpiness contained in the flat top of the displayed waveform; and the third is the risetime of the displayed waveform.

Determining the Level of the Display

The level of the display refers to the top of the displayed waveform. The waveform should show neither an upward nor downward slope anywhere along the top of the waveform. Any slope of the waveform can most easily be seen with a sweep rate of approximately 5 μ seconds per centimeter.

Checking the Bumpiness of the Display

The next characteristic to look for in the displayed waveform is the bumpiness in the top portion of the waveform immediately following the rise. This is the portion of the waveform affected by the delay line adjustments. To make this observation, use a sweep rate of approximately .2 μ seconds per centimeter.

There are two general types of bumps to be found in a poorly adjusted delay line. The first type is the irregularity caused by the misadjustment of a group of capacitors. This type is indicated by a fairly long duration bump. If the bumps occur at random intervals along the delay line, they are probably due to misadjustment of the delay line and can usually be corrected by a few slight adjustments. However, if there is a certain rhythmic waviness or symmetry to their appearance, the trouble may be due to a faulty adjustment in the terminating network. The trouble could

also be an improper adjustment of the amplifier high frequency compensation. In either case a complete adjustment may be necessary.

The second kind of bump is caused by misadjustment of a single delay line capacitor. This is indicated by a very short duration bump. This type can be easily corrected by readjustment of the misadjusted capacitor. The proper capacitor can be determined by observing the location of the bump on the displayed waveform.

Checking the Rise of the Displayed Waveform

The third characteristic to be investigated in the displayed waveform is the extreme leading edge and corner. This part of the waveform is affected by the vertical amplifier high frequency peaking coils and the delay line adjustments closest to the cathode-ray tube neck connections. These adjustments collectively determine the high frequency response of the vertical deflection system and for that reason are of the utmost importance.

The leading edge of the displayed waveform is best observed with a sweep speed of approximately .1 μ second per centimeter. The corner should be sharp as possible with no overshoot. While it is necessary that the corner be as sharp as possible for optimum frequency response, it is also necessary that there be no wrinkles or bumpiness in this portion of the display.

There is a good deal of similarity in the effect of the amplifier peaking coils and the delay line adjustments. For this reason, it is sometimes difficult to ascertain which adjustments are faulty. The adjustment at fault can usually be determined by the location and occurrence of the waveform irregularities.

NOTE

In the procedure that follows, the trimmer capacitors in the Type 545A Oscilloscope vertical amplifier are considered to be a part of the delay line. They are adjusted in the same manner as other delay line capacitors.

Physical Presetting

Perhaps the most important single bit of information for a line tuner is knowledge of the approximate positions of the various adjustments in a properly adjusted instrument. This knowledge will give him a good starting off point. And later, during the adjustment procedure, he can use the information as a check on his progress.

The variable inductors in the vertical amplifier and at the neck connections to the crt are normally preset so that the slugs are just out of the coils. They can be set by shining a light through the coil forms and adjusting the slugs. By presetting the slugs in this manner you will reduce the effects of the inductors during the delay line adjustment procedure. Then, during the last step of the adjustment procedure, you will move the slugs into the coils (usually about two or three turns).

If in your preliminary investigation, you detected a cyclic waviness in the display, or if there was extreme over-

Calibration Procedure — Type 545A

shoot at the leading edge, you will probably save yourself considerable time by presetting the variable inductors. Usually, turning the slugs too far out of the coil will only result in a rounding off of the leading edge. However, turning the slugs too far into the coil windings will result in severe wrinkles in the displayed waveform — wrinkles which can frequently be reduced by misadjusting the delay line. This might give you the impression that the delay line was at fault instead of the high frequency peaking coils.

The variable capacitors in the delay line will not, as a rule, require presetting. If the performance of the instrument has deteriorated as a result of normal use and handling, the delay line should require only touching up. The original physical positions of the capacitors should be very nearly correct. On the other hand, if the instrument has been tampered with, or if it has been subject to severe vibration or rough handling, it may be desirable to preset the delay line capacitors as described in the following paragraph.

In a properly adjusted delay line, the adjusting screw extends above the capacitor body about $\frac{3}{8}$ inch. The important characteristic is that the tops of all the delay line adjusting screws be about the same height. It is very important to keep this characteristic in mind as you adjust the delay line. Normally, trimmers located at points where fixed capacitors are connected across the delay line are somewhat higher than other trimmer capacitors.

If you can observe a waviness in the height of the adjusting screws (while at the same time, the display is level), the trouble is probably due to misadjustment of the inductors in the vertical amplifier. In this event, you should recheck the physical positions of the slugs as described in the previous paragraphs.

If, in the preliminary inspection, you noticed a bump following the termination bump, (that is, on the portion of the delay line not normally affected by delay line adjustments), be sure to check the termination inductors for balance. The slugs in both inductors should be equidistant from the coil windings. When you adjust the slugs, be sure to adjust each slug the same amount.

As a final step in the physical presetting procedure, dress the leads to the crt vertical-deflection plates. They are to be uniformly spaced both with respect to each other and with respect to the crt shield.

Establishing a Level Display

The level of the flat top of the displayed waveform is determined by the collective effect of all the delay line capacitors. When the delay line is properly adjusted, the top of the displayed waveform should be almost perfectly flat.

To make the display level, adjust each delay line capacitor a small amount in a direction that will result in a level display. Start at the termination network by adjusting the inductors and capacitors for a termination bump of minimum amplitude. Then, advance from capacitor to capacitor on the delay line, working toward the crt end. During your first attempt, you will probably find it most convenient to use a sweep rate of approximately 5 μ seconds per centimeter. After you have adjusted all of the capacitors to

gain an average level over the length of the flat top of the displayed waveform, you can advance the sweep rate to 2 μ seconds per centimeter and repeat the procedure. This time, however, try to adjust the capacitors for a smooth transition from bump to bump, while at the same time maintaining a satisfactory level. The important thing to remember is to reduce the amplitude of all the bumps by the same amount and not try to achieve a perfectly straight line at this time.

Removing the Bumps and Wrinkles

After you have established a level display with the amplitude of the bumps and wrinkles reduced to within a trace width of the level line, you can start to remove the wrinkles and bumps over smaller sections of the display. It is usually best to start at the terminated end of the delay line and work toward the crt end.

Set TIME/CM switch at .5 μ SEC and proceed to remove the bumps caused by the termination network. Do not try to arrive at a perfectly straight line during your first attempt. Just reduce the bumps by one-half. Then advance to the first group of 4 or 5 capacitors in the delay line and adjust them for a smooth line over the portion of the display that they affect. Keep in mind that each capacitor will only require a slight adjustment — a mere "touch" — and that it is the combined effect of the group of capacitors that you should be concerned with.

While you are adjusting a group of capacitors to remove a bump or wrinkle, be sure to frequently turn to a sweep rate of 2 or 5 microseconds/centimeter and check the level of the display.

Advance along the delay line from each group of capacitors to the next until you have traversed the entire length. Then, turn the TIME/CM switch to .02 μ SEC and repeat the process. This time, however, you must be extra careful. The capacitors that require adjustment will only need a slight touch — to do otherwise might nullify all of your efforts up to this point. Be sure to check the level of the display frequently. It is very easy to concentrate on removing a particularly stubborn bump and, in so doing, introduce an upward or downward slope in the display.

At this point in the adjustment procedure, it will not be necessary to adjust every capacitor. Touching up here and there will probably produce the desired results.

Adjusting the High Frequency Compensation

If you have successfully completed the adjustment procedure up to this point, the display should be level and free of bumps and wrinkles with a pronounced rolloff on the leading edge. During this final part of the adjustment procedure, you will strive for a square corner on the leading edge, while at the same time maintaining the proper level without introducing wrinkles or bumps.

Set the TIME/CM switch at .2 μ SEC and position the display to afford a good view of the leading edge and corner. The inductors in the vertical amplifier and near the crt affect this portion of the waveform. The delay line capacitors nearest the crt also affect the leading edge of the

waveform. It is important that you adjust each pair of inductors in conjunction with each other. Each inductor should be set at the same position as its corresponding-opposite inductor.

Adjust the inductors, in pairs for the squarest possible corner. It may be necessary to readjust the first two or three capacitors closest to the crt in order to achieve a wrinkle-free corner.

At this time the displayed waveform should be level on top, there should be virtually no bumps or wrinkles, and the risetime of the displayed waveform should be within specifications for the instrument. A risetime check on the displayed waveform gives a very good check on the completeness of the adjustments.

BANDPASS CHECKS

Install a properly calibrated Type K Unit in the oscilloscope and connect the output cable from the Constant-Amplitude Signal Generator to the INPUT Connector of the Type K Unit. Set the front-panel controls as follows:

STABILITY	full right
TRIGGERING LEVEL	any position

TRIGGER SLOPE	INT. (+ or —)
TRIGGERING MODE	AC LF REJECT, AC or DC
TIME/CM	1 MILLISEC
VARIABLE	CALIBRATED
HORIZONTAL DISPLAY	A

Type K Unit

AC/DC	DC
VOLTS/CM	.05
VARIABLE	CALIBRATED

Set the frequency controls on the Signal GENERATOR for an output frequency of 500 kc, and adjust the amplitude controls for a vertical deflection of exactly 4 centimeters. Position the display on the crt (with the VERTICAL POSITION control) so that the deflection extends exactly from the top graticule mark to the bottom graticule mark.

Then increase the output frequency of the Signal Generator to 30 mc (make sure the VOLTS/CM and VARIABLE controls are set to .05 and CALIBRATED, respectively); the deflection should be at least 2.8 centimeters at 30 mc. If not, the Vertical Amplifier and the Delay Line (and possible the Type K Unit) are in need of further adjustment.

PARTS LIST *and*

DIAGRAMS

Part Number	Value	Material	Construction	Voltage	Capacitance	Tektronix Part Number
C141	0.001	Cer.	Fixed	50V	1.0%	281-546
C142	0.001	Cer.	Fixed	50V	1.0%	281-546
C143	0.001	Cer.	Fixed	50V	1.0%	281-546
C144	0.001	Cer.	Fixed	50V	1.0%	281-546
C145	0.001	Cer.	Fixed	50V	1.0%	281-546
C146	0.001	Cer.	Fixed	50V	1.0%	281-546
C147	0.001	Cer.	Fixed	50V	1.0%	281-546
C148	0.001	Cer.	Fixed	50V	1.0%	281-546
C149	0.001	Cer.	Fixed	50V	1.0%	281-546
C150	0.001	Cer.	Fixed	50V	1.0%	281-546
C151	0.001	Cer.	Fixed	50V	1.0%	281-546
C152	0.001	Cer.	Fixed	50V	1.0%	281-546
C153	0.001	Cer.	Fixed	50V	1.0%	281-546
C154	0.001	Cer.	Fixed	50V	1.0%	281-546
C155	0.001	Cer.	Fixed	50V	1.0%	281-546
C156	0.001	Cer.	Fixed	50V	1.0%	281-546
C157	0.001	Cer.	Fixed	50V	1.0%	281-546
C158	0.001	Cer.	Fixed	50V	1.0%	281-546
C159	0.001	Cer.	Fixed	50V	1.0%	281-546
C160	0.001	Cer.	Fixed	50V	1.0%	281-546
C161	0.001	Cer.	Fixed	50V	1.0%	281-546
C162	0.001	Cer.	Fixed	50V	1.0%	281-546
C163	0.001	Cer.	Fixed	50V	1.0%	281-546
C164	0.001	Cer.	Fixed	50V	1.0%	281-546
C165	0.001	Cer.	Fixed	50V	1.0%	281-546
C166	0.001	Cer.	Fixed	50V	1.0%	281-546
C167	0.001	Cer.	Fixed	50V	1.0%	281-546
C168	0.001	Cer.	Fixed	50V	1.0%	281-546
C169	0.001	Cer.	Fixed	50V	1.0%	281-546
C170	0.001	Cer.	Fixed	50V	1.0%	281-546
C171	0.001	Cer.	Fixed	50V	1.0%	281-546
C172	0.001	Cer.	Fixed	50V	1.0%	281-546
C173	0.001	Cer.	Fixed	50V	1.0%	281-546
C174	0.001	Cer.	Fixed	50V	1.0%	281-546
C175	0.001	Cer.	Fixed	50V	1.0%	281-546
C176	0.001	Cer.	Fixed	50V	1.0%	281-546
C177	0.001	Cer.	Fixed	50V	1.0%	281-546
C178	0.001	Cer.	Fixed	50V	1.0%	281-546
C179	0.001	Cer.	Fixed	50V	1.0%	281-546
C180	0.001	Cer.	Fixed	50V	1.0%	281-546
C181	0.001	Cer.	Fixed	50V	1.0%	281-546
C182	0.001	Cer.	Fixed	50V	1.0%	281-546
C183	0.001	Cer.	Fixed	50V	1.0%	281-546
C184	0.001	Cer.	Fixed	50V	1.0%	281-546
C185	0.001	Cer.	Fixed	50V	1.0%	281-546
C186	0.001	Cer.	Fixed	50V	1.0%	281-546
C187	0.001	Cer.	Fixed	50V	1.0%	281-546
C188	0.001	Cer.	Fixed	50V	1.0%	281-546
C189	0.001	Cer.	Fixed	50V	1.0%	281-546
C190	0.001	Cer.	Fixed	50V	1.0%	281-546
C191	0.001	Cer.	Fixed	50V	1.0%	281-546
C192	0.001	Cer.	Fixed	50V	1.0%	281-546
C193	0.001	Cer.	Fixed	50V	1.0%	281-546
C194	0.001	Cer.	Fixed	50V	1.0%	281-546
C195	0.001	Cer.	Fixed	50V	1.0%	281-546
C196	0.001	Cer.	Fixed	50V	1.0%	281-546
C197	0.001	Cer.	Fixed	50V	1.0%	281-546
C198	0.001	Cer.	Fixed	50V	1.0%	281-546
C199	0.001	Cer.	Fixed	50V	1.0%	281-546
C200	0.001	Cer.	Fixed	50V	1.0%	281-546

Cer. Ceramic
Comp. Composition
EMC Electrolytic, metal cased
f Farad
G Giga, or 10⁹
GMV Guaranteed minimum value
h Henry
K or k Kilohms or kilo (10³)
M/Cer. Mica or Ceramic
M or meg Megohms or mega (10⁶)
μ Micro, or 10⁻⁶
μμ Micromicro or 10⁻¹²
m milli or 10⁻³

ABBREVIATIONS

n Nano or 10⁻⁹
Ω ohm
p Pico or 10⁻¹²
PTB Paper, "Bathtub"
PMC Paper, metal cased
Poly. Polystyrene
Prec. Precision
PT Paper Tubular
T Terra or 10¹²
v Working volts DC
Var. Variable
w Watt
WW Wire-wound

SPECIAL NOTES AND SYMBOLS

+ and up
† Approximate serial number.
X000 Part first added at this serial number.
000X Part removed after this serial number.
* 000-000 Asterisk preceding Tektronix Part Number indicates manufactured by or for Tektronix, also reworked or checked components.
(Mod. w/) Simple replacement not recommended.
Modify to value for later instruments and change other parts to match.



MANUFACTURERS OF CATHODE-RAY OSCILLOSCOPES

HOW TO ORDER PARTS

Replacement parts are available through your local Tektronix Field Office.

Improvements in Tektronix instruments are incorporated as soon as available. Therefore, when ordering a replacement part it is important to supply the part number including any suffix, instrument type, serial number, plus a modification number where applicable.

If the part you have ordered has been improved or replaced, your local Field Office will contact you if there is a change in part number.

PARTS LIST

ABBREVIATIONS

Cer.	Ceramic	m	milli or 10 ⁻³
Comp.	Composition	Ω	ohm
EMC	Electrolytic, metal cased	PTB	Paper, "Bathtub"
f	Farad	PMC	Paper, metal cased
GMV	Guaranteed Minimum value	Poly.	Polystyrene
h	Henry	Prec.	Precision
k	Kilohm or 10 ³ ohms	PT	Paper Tubular
M/Cer.	Mica or Ceramic	v	Working volts DC
meg	Megohm or 10 ⁶ ohms	Var.	Variable
μ	Micro. or 10 ⁻⁶	w	Watt
μμ	Micromicro or 10 ⁻¹²	WW	Wire-wound

Special Notes and Symbols

+ and up

† Approximate serial number.

X000 Part first added at this serial number.

000X Part removed after this serial number.

(Mod. w/) Simple replacement not recommended. Modify to value for later instruments and change other parts to match.

Bulbs

		Tektronix Part Number
B129	NE-2	150-002
B160W	NE-2	150-002
B167	NE-2	150-002
B171	NE-2	150-002
B267	NE-2	150-002
B271	NE-2	150-002
B347	NE-2	150-002
B386	NE-2	150-002
B397	NE-2	150-002
B398	NE-2	150-002
B434A	NE-2	150-002
B434B	NE-2	150-002
B601	Incandescent, #47	150-001
B602	Incandescent, #47	150-001
B603	Incandescent, #47	150-001
B1083	NE-2	150-002
B1087	NE-2	150-002

Capacitors

C1	4.7 μμf	Cer.	Fixed	500 v	±1 μμf	281-501
C10	.0022 μf	PTM	Fixed	400 v		Use 285-543
C11	100 μμf	Cer.	Fixed	350 v	±20 μμf	281-523
C15	.001 μf	Cer.	Fixed	500 v		283-000
C20	.001 μf	Cer.	Fixed	500 v		283-000

Capacitors (continued)

							Tektronix Part Number
C24		47 $\mu\mu\text{f}$	Cer.	Fixed	500 v	$\pm 9.4 \mu\mu\text{f}$	281-518
C31		.01 μf	PTM	Fixed	400 v		285-510
C37		22 $\mu\mu\text{f}$	Cer.	Fixed	500 v	$\pm 4.4 \mu\mu\text{f}$	281-510
C47		.005 μf	Cer.	Fixed	500 v		283-001
C51		6.8 $\mu\mu\text{f}$	Cer.	Fixed	500 v		281-541
C60		.001 μf	PTM	Fixed	600 v		285-501
C65		.001 μf	Cer.	Fixed	500 v		283-000
C70		.001 μf	Cer.	Fixed	500 v		283-000
C74	20420-up	.005 μf	Cer.	Fixed	500 v		283-001
C76	20420-up	.005 μf	Cer.	Fixed	500 v		283-001
C78		.001 μf	Cer.	Fixed	500 v		283-000
C81		.005 μf	Cer.	Fixed	500 v		283-001
C87		22 $\mu\mu\text{f}$	Cer.	Fixed	500 v	$\pm 2.2 \mu\mu\text{f}$	281-511
C102		22 $\mu\mu\text{f}$	Cer.	Fixed	500 v	$\pm 2.2 \mu\mu\text{f}$	281-511
C103		.001 μf	Cer.	Fixed	500 v		283-000
C105		.001 μf	Cer.	Fixed	500 v		283-000
C109		.005 μf	Cer.	Fixed	500 v		283-001
C116		.001 μf	Cer.	Fixed	500 v		283-000
C123		10 $\mu\mu\text{f}$	Cer.	Fixed	500 v	$\pm 1 \mu\mu\text{f}$	281-504
C129		.005 μf	Cer.	Fixed	500 v		283-001
C131		27 $\mu\mu\text{f}$	Cer.	Fixed	500 v	$\pm 5.4 \mu\mu\text{f}$	281-513
C134		8 $\mu\mu\text{f}$	Cer.	Fixed	500 v	$\pm 0.5 \mu\mu\text{f}$	281-503
C138		.005 μf	Cer.	Fixed	500 v		283-001
C141		8 $\mu\mu\text{f}$	Cer.	Fixed	500 v	$\pm 0.5 \mu\mu\text{f}$	281-503
C150		82 $\mu\mu\text{f}$	Cer.	Fixed	500 v	$\pm 8.2 \mu\mu\text{f}$	281-528
C151		.005 μf	Cer.	Fixed	500 v		283-001
C157		12 $\mu\mu\text{f}$	Cer.	Fixed	500 v	$\pm 2 \mu\mu\text{f}$	281-506
C160A		3-12 $\mu\mu\text{f}$	Cer.	Var.			281-007
C160B		82 $\mu\mu\text{f}$	Mica	Fixed		5%	283-534
C160C		4.5-25 $\mu\mu\text{f}$	Cer.	Var.			281-010
C160D		82 $\mu\mu\text{f}$	Mica	Fixed		5%	283-534
C160E		4.5-25 $\mu\mu\text{f}$	Cer.	Var.			281-010
C160F		.001 μf	Mylar			$\pm 1/2 \%$	*291-008
C160G		.01 μf	} Mylar timing series				
C160H		.1 μf				$\pm 1/2 \%$	*291-007
C160J		1 μf					
C160K	X31660-up	270 $\mu\mu\text{f}$	Cer.	Fixed	500 v		281-543
C165	20001-20002	82 $\mu\mu\text{f}$	Cer.	Fixed	500 v	5%	281-528
C165	20003-up	470 $\mu\mu\text{f}$	Cer.	Fixed	500 v	$\pm 94 \mu\mu\text{f}$	281-525
C167		.001 μf	Cer.	Fixed	500 v		283-000
C180A		220 $\mu\mu\text{f}$	Mica	Fixed		10%	283-536
C180B		.0022 μf	PTM	Fixed	400 v		285-543
C180C		.022 μf	PTM	Fixed	400 v		285-515
C180D		.1 μf	PTM	Fixed	400 v		285-526
C180E		.1 μf	PTM	Fixed	400 v		285-526
C181	20001-20129	39 $\mu\mu\text{f}$	Cer.	Fixed	500 v	$\pm 3.9 \mu\mu\text{f}$	281-517
C181	20130-up	27 $\mu\mu\text{f}$	Cer.	Fixed	500 v	$\pm 1.35 \mu\mu\text{f}$	281-515
C187		.005 μf	Cer.	Fixed	500 v		283-001
C190	20001-20988	18 $\mu\mu\text{f}$	Cer.	Fixed	500 v	$\pm 10 \%$	Use 281-509
C190	20989-up	15 $\mu\mu\text{f}$	Cer.	Fixed	500 v	$\pm 10 \%$	281-509
C193		.005 μf	Cer.	Fixed	500 v		283-001
C196		.001 μf	Cer.	Fixed	500 v		283-000

Capacitors (continued)

							Tektronix Part Number
C221		47 $\mu\mu\text{f}$	Cer.	Fixed	500 v	$\pm 9.4 \mu\mu\text{f}$	281-518
C234		10 $\mu\mu\text{f}$	Cer.	Fixed	500 v	$\pm 1 \mu\mu\text{f}$	281-504
C241		3.3 $\mu\mu\text{f}$	Cer.	Fixed		$\pm .25 \mu\mu\text{f}$	281-534
C250		39 $\mu\mu\text{f}$	Cer.	Fixed	500 v	$\pm 3.9 \mu\mu\text{f}$	281-516
C260A		3-12 $\mu\mu\text{f}$	Cer.	Var.			281-007
C260B		39 $\mu\mu\text{f}$	Mica	Fixed	500 v	5%	283-533
C260C		7-45 $\mu\mu\text{f}$	Cer.	Var.			281-012
C260D	20001-24951	.00046 μf	}	Manufactured by Tektronix			291-026
C260D	24952-up	480 $\mu\mu\text{f}$					
C260E		.005 μf					
C260F		.05 μf					
C260G		.5 μf					
C267		.001 μf	Cer.	Fixed	500 v		283-000
C280A		22 $\mu\mu\text{f}$	Cer.	Fixed	500 v	$\pm 4.4 \mu\mu\text{f}$	281-510
C280B		470 $\mu\mu\text{f}$	Cer.	Fixed		$\pm 94 \mu\mu\text{f}$	281-252
C280C		.0047 μf	PTM	Fixed	400 v		285-506
C280D		.047 μf	PTM	Fixed	400 v		285-519
C280E		.047 μf	PTM	Fixed	400 v		285-519
C295		15 $\mu\mu\text{f}$	Cer.	Fixed	500 v	$\pm 1.5 \mu\mu\text{f}$	281-509
C301C		7-45 $\mu\mu\text{f}$	Cer.	Var.			281-012
C301E		330 $\mu\mu\text{f}$	Cer.	Fixed	500 v	$\pm 10\%$	281-546
C301H	20001-20002	22 $\mu\mu\text{f}$	Cer.	Fixed	500 v		281-511
C301H	20003-up	12 $\mu\mu\text{f}$	Cer.	Fixed	500 v	$\pm 1.2 \mu\mu\text{f}$	281-506
C320		.005 μf	Cer.	Fixed	500 v		283-001
C330		4.5-25 $\mu\mu\text{f}$	Cer.	Var.	500 v		281-010
C336		.005 μf	Cer.	Fixed	500 v		283-001
C340		4.7 $\mu\mu\text{f}$	Cer.	Fixed	500 v	$\pm 1 \mu\mu\text{f}$	281-501
C347		.001 μf	Cer.	Fixed	500 v		283-000
C348		3-12 $\mu\mu\text{f}$	Cer.	Var.	500 v		281-007
C355		1.5 $\mu\mu\text{f}$	Cer.	Fixed	500 v	$\pm 0.5 \mu\mu\text{f}$	281-526
C356		.005 μf	Cer.	Fixed	500 v		283-001
C364		3-12 $\mu\mu\text{f}$	Cer.	Var.	500 v		281-036
C375		9-180 $\mu\mu\text{f}$	Mica	Var.	500 v		281-023
C380		6.25 μf	EMT	Fixed	300 v		290-000
C384		3-12 $\mu\mu\text{f}$	Cer.	Var.	500 v		281-036
C390		4.7 $\mu\mu\text{f}$	Cer.	Fixed	500 v	$\pm 1 \mu\mu\text{f}$	281-501
C393		.047 μf	PTM	Fixed	400 v		285-519
C396	23190-up	.005 μf	Cer.	Fixed	500 v		283-001
C421		.01 μf	Cer.	Fixed	500 v		283-002
C426		.005 μf	Cer.	Fixed	500 v		283-001
C444		22 $\mu\mu\text{f}$	Cer.	Fixed	500 v	$\pm 2.2 \mu\mu\text{f}$	281-511
C454		47 $\mu\mu\text{f}$	Cer.	Fixed	500 v	$\pm 9.4 \mu\mu\text{f}$	281-518
C457		.005 μf	Cer.	Fixed	500 v		283-001
C601	20,001-27729	.02 μf	Cer.	Fixed	150 v		283-004
C601	27730-up	.1 μf	Cer.	Discap	500 v		283-008
C610		.01 μf	PTM	Fixed	400 v		285-510
C617		.01 μf	PTM	Fixed	400 v		285-510
C628		.01 μf	PTM	Fixed	400 v		285-510
C640		125 μf	EMC	Fixed	350 v		290-044
C648		.01 μf	Cer.	Fixed	500 v		283-002
C649		2 x 40 μf	EMC	Fixed	250 v		290-040
C650		.01 μf	PTM	Fixed	400 v		285-510

Capacitors (continued)

						Tektronix Part Number
C670		150 μ f	EMC	Fixed	250 v	290-048
C671		150 μ f	EMC	Fixed	250 v	290-048
C679A,B,C		3 x 10 μ f	EMC	Fixed	450 v	290-033
C680		.01 μ f	PTM	Fixed	400 v	285-510
C688		.01 μ f	PTM	Fixed	400 v	285-510
C700		125 μ f	EMC	Fixed	450 v	290-045
C710	20001-21649	.01 μ f	PTM	Fixed	400 v	Use 285-511
C710	21650 up	.01 μ f	PTM	Fixed	600 v	285-511
C730		125 μ f	EMC	Fixed	350 v	290-044
C740		.01 μ f	PTM	Fixed	400 v	285-510
C760A,B		2 x 40 μ f	EMC	Fixed	450 v	290-042
C775		.005 μ f	Cer.	Fixed	500 v	283-001
C777		.005 μ f	Cer.	Fixed	500 v	283-001
C780		.005 μ f	Cer.	Fixed	500 v	283-001
C783		.01 μ f	Cer.	Fixed	500 v	283-002
C785		.01 μ f	Cer.	Fixed	500 v	283-002
C801		.047 μ f	PTM	Fixed	400 v	285-519
C802		2 x 20 μ f	EMC	Fixed	450 v	290-037
C803		.001 μ f	PTM	Fixed	600 v	285-501
C806		.01 μ f	PTM	Fixed	400 v	285-510
C808		.001 μ f	PTM	Fixed	600 v	285-501
C819	X28860-up	.1 μ f	Cer.	Fixed	100 v	283-012
C820	20001-24920	.0068 μ f	PTM	Fixed	3000 v	285-508
C820	24921-up	.01 μ f	Cer.	Fixed	2000 v	283-011
C821	20001-23289	.015 μ f	PTM	Fixed	3000 v	285-513
C821	23290-up	.01 μ f	Cer.	Fixed	2000 v	283-011
C822	20130-up	470 μ mf	Cer.	Fixed		$\pm 94 \mu$ mf 281-525
C827	20001-23289	.015 μ f	PTM	Fixed	3000 v	285-513
C827	23290-up	.01 μ f	Cer.	Fixed	2000 v	283-011
C828	23290-up	.01 μ f	Cer.	Fixed	2000 v	283-011
C829	X28860-up	.001 μ f	Cer.	Fixed	500 v	283-000
C831	20001--24920	.0068 μ f	PTM	Fixed	3000 v	285-508
C831	24921-up	.01 μ f	Cer.	Fixed	2000 v	283-011
C832	20001-23839	.0068 μ f	PTM	Fixed	5000 v	Use 283-034
C832	23840-up	.005 μ f	Cer.	Fixed	4000 v	283-034
C833	20001-23106	.00047 μ f	PTM	Fixed	10,000 v	Use 281-556
C833	23107-up	500 μ mf	Cer.	Fixed	10,000 v	281-556
C834	20001-23106	.00047 μ f	PTM	Fixed	10,000 v	Use 281-556
C834	23107-up	500 μ mf	Cer.	Fixed	10,000 v	281-556
C836	20001-23106	.00047 μ f	PTM	Fixed	10,000 v	Use 281-556
C836	23107-up	500 μ mf	Cer.	Fixed	10,000 v	281-556
C841		.01 μ f	Cer.	Fixed	500 v	283-002
C842	20001-24920	.0068 μ f	PTM	Fixed	3000 v	285-508
C842	24921-up	.01 μ f	Cer.	Fixed	2000 v	283-011
C845	20001-23289	.015 μ f	PTM	Fixed	3000 v	285-513
C845	23290-up	.01 μ f	Cer.	Fixed	2000 v	283-011
C848	20001-23289	.015 μ f	PTM	Fixed	3000 v	285-513
C848	23290-up	.01 μ f	Cer.	Fixed	2000 v	283-011
C871		330 μ mf	Mica	Fixed	500 v	10% 283-518
C874		330 μ f	Mica	Fixed	500 v	10% 283-518

Capacitors (continued)

						Tektronix Part Number
C885	27 μmf	Cer.	Fixed	500 v	$\pm 5.4 \mu\text{mf}$	281-513
C897	.001 μf	Cer.	Fixed	500 v		283-000
C1003	2 x 20 μf	EMC	Fixed	450 v		290-036
C1005A	40 μf	EMC	Fixed	475 v	}	290-063
C1005B	20 μf	EMC	Fixed	475 v		
C1005C	10 μf	EMC	Fixed	475 v		
C1007	.1 μf	PTM	Fixed	400 v		285-526
C1013	.005 μf	Cer.	Fixed	500 v		283-001
C1029	.001 μf	Cer.	Fixed	500 v		283-000
C1031	.005 μf	Cer.	Fixed	500 v		283-001
C1033	.005 μf	Cer.	Fixed	500 v		283-001
C1039	.001 μf	Cer.	Fixed	500 v	10%	281-536
C1049	.001 μf	Cer.	Fixed	500 v	10%	281-536
C1052	.001 μf	Cer.	Fixed	500 v		283-000
C1054	.005 μf	Cer.	Fixed	500 v		283-001
C1056	150 $\mu\mu\text{f}$	Cer.	Fixed	500 v	$\pm 30 \mu\text{mf}$	281-524
C1062	.001 μf	Cer.	Fixed	500 v		283-000
C1075	8-50 $\mu\mu\text{f}$	Cer.	Var.	500 v		281-022
C1077	8-50 $\mu\mu\text{f}$	Cer.	Var.	500 v		281-022
C1078	.7-3 $\mu\mu\text{f}$	Tub.	Var.	500 v		281-027
C1085	.005 μf	Cer.	Fixed	500 v		283-001
C1089	.005 μf	Cer.	Fixed	500 v		283-001
C1093A,B,C,D	4 x 75 μf	EMC	Fixed	150 v		290-071
C1102	.001 μf	Cer.	Fixed	500 v		283-000
C1104	.7-3 $\mu\mu\text{f}$	Tub.	Var.	500 v		281-027
C1105	150 $\mu\mu\text{f}$	Cer.	Fixed	500 v	$\pm 30 \mu\text{mf}$	281-524
C1106	150 $\mu\mu\text{f}$	Cer.	Fixed	500 v	$\pm 30 \mu\text{mf}$	281-524
C1112	.001 μf	Cer.	Fixed	500 v		283-000
C1122	.001 μf	Cer.	Fixed	500 v		283-000
C1124	.7-3 $\mu\mu\text{f}$	Tub.	Var.	500 v		281-027
C1126	150 $\mu\mu\text{f}$	Cer.	Fixed	500 v	$\pm 30 \mu\text{mf}$	281-524
C1132	.001 μf	Cer.	Fixed	500 v		283-000
C1142	.001 μf	Cer.	Fixed	500 v		283-000
C1144	.7-3 $\mu\mu\text{f}$	Tub.	Var.	500 v		281-027
C1146	150 $\mu\mu\text{f}$	Cer.	Fixed	500 v	$\pm 30 \mu\text{mf}$	281-524
C1152	.001 μf	Cer.	Fixed	500 v		283-000
C1162	.001 μf	Cer.	Fixed	500 v		283-000
C1164	.7-3 $\mu\mu\text{f}$	Tub.	Var.	500 v		281-027
C1166	150 $\mu\mu\text{f}$	Cer.	Fixed	500 v	$\pm 30 \mu\text{mf}$	281-524
C1172	.001 μf	Cer.	Fixed	500 v		283-000
C1182	.001 μf	Cer.	Fixed	500 v		283-000
C1184	.7-3 $\mu\mu\text{f}$	Tub.	Var.	500 v		281-027
C1186	150 $\mu\mu\text{f}$	Cer.	Fixed	500 v	$\pm 30 \mu\text{mf}$	281-524
C1192	.001 μf	Cer.	Fixed	500 v	GMV	283-000
C1202	.001 μf	Cer.	Fixed	500 v	GMV	283-000
C1204	.7-3 $\mu\mu\text{f}$	Tub.	Var.	500 v		281-027
C1205	150 $\mu\mu\text{f}$	Cer.	Fixed	500 v	20%	281-524
C1208	.005 μf	Cer.	Fixed	500 v	GMV	283-001
C1212	.001 μf	Cer.	Fixed	500 v	GMV	283-000
C1223	.001 μf	Cer.	Fixed	500 v	GMV	283-000
C1228	.022 μf	PTM	Fixed	600 v	20%	285-517

Capacitors (continued)

						Tektronix Part Number
C1301	.7-3 $\mu\mu\text{f}$	Tub.	Var.	500 v		281-037
C1302	.7-3 $\mu\mu\text{f}$	Tub.	Var.	500 v		281-037
C1303	.7-3 $\mu\mu\text{f}$	Tub.	Var.	500 v		281-037
C1304	.7-3 $\mu\mu\text{f}$	Tub.	Var.	500 v		281-037
C1305	.7-3 $\mu\mu\text{f}$	Tub.	Var.	500 v		281-037
C1306	.7-3 $\mu\mu\text{f}$	Tub.	Var.	500 v		281-037
C1307	.7-3 $\mu\mu\text{f}$	Tub.	Var.	500 v		281-037
C1308	.7-3 $\mu\mu\text{f}$	Tub.	Var.	500 v		281-037
C1309	.7-3 $\mu\mu\text{f}$	Tub.	Var.	500 v		281-037
C1310	.7-3 $\mu\mu\text{f}$	Tub.	Var.	500 v		281-037
C1311	.7-3 $\mu\mu\text{f}$	Tub.	Var.	500 v		281-037
C1312	.7-3 $\mu\mu\text{f}$	Tub.	Var.	500 v		281-037
C1313	.7-3 $\mu\mu\text{f}$	Tub.	Var.	500 v		281-037
C1314	.7-3 $\mu\mu\text{f}$	Tub.	Var.	500 v		281-037
C1315	.7-3 $\mu\mu\text{f}$	Tub.	Var.	500 v		281-037
C1316	.7-3 $\mu\mu\text{f}$	Tub.	Var.	500 v		281-037
C1317	.7-3 $\mu\mu\text{f}$	Tub.	Var.	500 v		281-037
C1318	.7-3 $\mu\mu\text{f}$	Tub.	Var.	500 v		281-037
C1319	.7-3 $\mu\mu\text{f}$	Tub.	Var.	500 v		281-037
C1320	.7-3 $\mu\mu\text{f}$	Tub.	Var.	500 v		281-037
C1321	.7-3 $\mu\mu\text{f}$	Tub.	Var.	500 v		281-037
C1322	.7-3 $\mu\mu\text{f}$	Tub.	Var.	500 v		281-037
C1323	.7-3 $\mu\mu\text{f}$	Tub.	Var.	500 v		281-037
C1324	.7-3 $\mu\mu\text{f}$	Tub.	Var.	500 v		281-037
C1325	.7-3 $\mu\mu\text{f}$	Tub.	Var.	500 v		281-037
C1326	.7-3 $\mu\mu\text{f}$	Tub.	Var.	500 v		281-037
C1327	.7-3 $\mu\mu\text{f}$	Tub.	Var.	500 v		281-037
C1328	.7-3 $\mu\mu\text{f}$	Tub.	Var.	500 v		281-037
C1329	.7-3 $\mu\mu\text{f}$	Tub.	Var.	500 v		281-037
C1330	.7-3 $\mu\mu\text{f}$	Tub.	Var.	500 v		281-037
C1331	.7-3 $\mu\mu\text{f}$	Tub.	Var.	500 v		281-037
C1332	.7-3 $\mu\mu\text{f}$	Tub.	Var.	500 v		281-037
C1333	.7-3 $\mu\mu\text{f}$	Tub.	Var.	500 v		281-037
C1334	.7-3 $\mu\mu\text{f}$	Tub.	Var.	500 v		281-037
C1335	.7-3 $\mu\mu\text{f}$	Tub.	Var.	500 v		281-037
C1336	.7-3 $\mu\mu\text{f}$	Tub.	Var.	500 v		281-037
C1337	.7-3 $\mu\mu\text{f}$	Tub.	Var.	500 v		281-037
C1338	.7-3 $\mu\mu\text{f}$	Tub.	Var.	500 v		281-037
C1339	.7-3 $\mu\mu\text{f}$	Tub.	Var.	500 v		281-037
C1340	.7-3 $\mu\mu\text{f}$	Tub.	Var.	500 v		281-037
C1341	.7-3 $\mu\mu\text{f}$	Tub.	Var.	500 v		281-037
C1342	.7-3 $\mu\mu\text{f}$	Tub.	Var.	500 v		281-037
C1343	.7-3 $\mu\mu\text{f}$	Tub.	Var.	500 v		281-037
C1344	.7-3 $\mu\mu\text{f}$	Tub.	Var.	500 v		281-037
C1345	.7-3 $\mu\mu\text{f}$	Tub.	Var.	500 v		281-037
C1346	.7-3 $\mu\mu\text{f}$	Tub.	Var.	500 v		281-037
C1347	.7-3 $\mu\mu\text{f}$	Tub.	Var.	500 v		281-037
C1348	.7-3 $\mu\mu\text{f}$	Tub.	Var.	500 v		281-037
C1349	.7-3 $\mu\mu\text{f}$	Tub.	Var.	500 v		281-037
C1350	.7-3 $\mu\mu\text{f}$	Tub.	Var.	500 v		281-037

Capacitors (continued)

							Tektronix Part Number
C1360		1.5 $\mu\mu\text{f}$	Cer.	Fixed	500 v	$\pm 0.25 \mu\mu\text{f}$	281-529
C1361		1.5 $\mu\mu\text{f}$	Cer.	Fixed	500 v	$\pm 0.25 \mu\mu\text{f}$	281-529
C1362		1.5 $\mu\mu\text{f}$	Cer.	Fixed	500 v	$\pm 0.25 \mu\mu\text{f}$	281-529
C1363		1.5 $\mu\mu\text{f}$	Cer.	Fixed	500 v	$\pm 0.25 \mu\mu\text{f}$	281-529
C1364		1.5 $\mu\mu\text{f}$	Cer.	Fixed	500 v	$\pm 0.25 \mu\mu\text{f}$	281-529
C1365		1.5 $\mu\mu\text{f}$	Cer.	Fixed	500 v	$\pm 0.25 \mu\mu\text{f}$	281-529
C1366		1.5 $\mu\mu\text{f}$	Cer.	Fixed	500 v	$\pm 0.25 \mu\mu\text{f}$	281-529
C1367		1.5 $\mu\mu\text{f}$	Cer.	Fixed	500 v	$\pm 0.25 \mu\mu\text{f}$	281-529
C1368		1.5 $\mu\mu\text{f}$	Cer.	Fixed	500 v	$\pm 0.25 \mu\mu\text{f}$	281-529
C1369		1.5 $\mu\mu\text{f}$	Cer.	Fixed	500 v	$\pm 0.25 \mu\mu\text{f}$	281-529
C1370		1.5 $\mu\mu\text{f}$	Cer.	Fixed	500 v	$\pm 0.25 \mu\mu\text{f}$	281-529
C1371		1.5 $\mu\mu\text{f}$	Cer.	Fixed	500 v	$\pm 0.25 \mu\mu\text{f}$	281-529
C1372		1.5 $\mu\mu\text{f}$	Cer.	Fixed	500 v	$\pm 0.25 \mu\mu\text{f}$	281-529
C1373		1.5 $\mu\mu\text{f}$	Cer.	Fixed	500 v	$\pm 0.25 \mu\mu\text{f}$	281-529
C1374		1.5 $\mu\mu\text{f}$	Cer.	Fixed	500 v	$\pm 0.25 \mu\mu\text{f}$	281-529
C1375		1.5 $\mu\mu\text{f}$	Cer.	Fixed	500 v	$\pm 0.25 \mu\mu\text{f}$	281-529
C1380		.68 $\mu\mu\text{f}$	Cer.	Fixed	500 v	$\pm 0.136 \mu\mu\text{f}$	281-537
C1381		.68 $\mu\mu\text{f}$	Cer.	Fixed	500 v	$\pm 0.136 \mu\mu\text{f}$	281-537
C1382		1 $\mu\mu\text{f}$	Cer.	Fixed	500 v	$\pm 0.2 \mu\mu\text{f}$	281-538
C1384		.68 $\mu\mu\text{f}$	Cer.	Fixed	500 v	$\pm 0.136 \mu\mu\text{f}$	281-537
C1385		.68 $\mu\mu\text{f}$	Cer.	Fixed	500 v	$\pm 0.136 \mu\mu\text{f}$	281-537

Diodes

D122		T12G or HD2607					152-008
D131	21109-up	T12G					152-008
D642A,B,C,D		Silicon Diode					152-047
D672A,B,C,D		Silicon Diode					152-047
D679	X29230-up	Silicon Diode					152-047
D702A,B,		Silicon Diode					152-047
D732A,B		Silicon Diode					152-047
D762A,B,C,D		Silicon Diode					152-047

Fuses

F601		6.25 amp, Slo-Blo 3AG for 117 v operation	50 cycle				159-011
F601		6 amp, Fast-Blo 3AG for 117 v operation	60 cycle				159-013
F601		3 amp, Fast-Blo 3AG for 234 v operation	60 cycle				159-015
F601		3 amp, Slo-Blo 3AG for 234 v operation	50 cycle				159-005
F1054	X29960-up	150 MA, Fast-Blo					159-049

Inductors

LR149		1.2 mh	Fixed				108-164
L249		4.7 mh	Fixed				108-165
L424		280 μh	Fixed				108-015
L1014		1.8-3.9 μh	Var.	core 276-506			114-112
L1015		.45 μh	Fixed				108-062
L1024		1.8-3.9 μh	Var.	core 276-506			114-112
L1025		.45 μh	Fixed				108-062
L1036		.3-.55 μh	Var.	core 276-506			114-111
L1046		.3-.55 μh	Var.	core 276-506			114-111
LR1064		8.4 μh	Fixed				108-157
L1071		.3-.5 μh	Var.	core 276-506			114-092
L1073		.3-.5 μh	Var.	core 276-506			114-092
L1103		Grid Line					108-145
L1104		Plate line					108-139
L1113		Grid Line					108-145
L1114		Plate line					108-139
L1304		Delay Line 30 section Coil	Fixed			Use	108-177
L1305		Delay Line 30 section Coil	Fixed			Use	108-177
L1334		Delay Line 20 section Coil	Fixed			Use	108-176

Inductors

L1335	Delay Line 20 section Coil	Fixed
L1354	.9-1.6 μ h	Var.
L1355	.9-1.6 μ h	Var.

Tektronix
Part Number
Use 108-176
114-038
114-038

Resistors

R1		1 meg	1/2 w	Fixed	Comp.	5%	301-105
R2		390 k	1/2 w	Fixed	Comp.	5%	301-394
R3		50 k	2 w	Var.	Comp.	20%	311-023
R4		100 k	1/2 w	Fixed	Comp.	10%	302-104
R12		1 meg	1/2 w	Fixed	Comp.	10%	302-105
R13		100 k	1/2 w	Fixed	Comp.	10%	302-104
R15		470 k	1/2 w	Fixed	Comp.	10%	302-474
R17*		100 k	2 w	Var.	Comp.	20%	311-096
R18		22 k	1/2 w	Fixed	Comp.	10%	302-223
R19		470 k	1/2 w	Fixed	Comp.	10%	302-474
R20		56 k	1/2 w	Fixed	Comp.	10%	302-563
R22		47 Ω	1/2 w	Fixed	Comp.	10%	302-470
R23		47 Ω	1/2 w	Fixed	Comp.	10%	302-470
R24		4.7 k	1 w	Fixed	Comp.	10%	304-472
R25		4.7 k	1 w	Fixed	Comp.	10%	304-472
R28		33 k	2 w	Fixed	Comp.	10%	306-333
R29		39 k	2 w	Fixed	Comp.	10%	306-393
R31		47 k	1/2 w	Fixed	Comp.	10%	302-473
R32		47 k	1/2 w	Fixed	Comp.	10%	302-473
R33		47 Ω	1/2 w	Fixed	Comp.	10%	302-470
R34		680 Ω	1/2 w	Fixed	Comp.	10%	302-681
R35		1.5 k	1/2 w	Fixed	Comp.	10%	302-152
R37		100 k	1/2 w	Fixed	Comp.	10%	302-104
R38		120 k	1/2 w	Fixed	Comp.	10%	302-124
R39		100 k	2 w	Var.	Comp.	20%	311-026
R40		2.7 meg	1/2 w	Fixed	Comp.	10%	302-275
R41		47 Ω	1/2 w	Fixed	Comp.	10%	302-470
R43	20001-21108	820 Ω	1/2 w	Fixed	Comp.	10%	Use 302-152
R43	21109-up	1.5 k	1/2 w	Fixed	Comp.	10%	302-152
R44		1 meg	1/2 w	Fixed	Comp.	10%	302-105
R46		18 k	1 w	Fixed	Comp.	10%	304-183
R47		500 Ω	2 w	Var.	Comp.	10%	311-005
R48		18 k	1 w	Fixed	Comp.	10%	304-183
R51	20001-22409	1 meg	1/2 w	Fixed	Comp.	10%	Use 301-105
R51	22410-up	1 meg	1/2 w	Fixed	Comp.	5%	301-105
R52	20001-22409	390 k	1/2 w	Fixed	Comp.	10%	Use 301-394
R52	22410-up	390 k	1/2 w	Fixed	Comp.	5%	301-394
R53		50 k	.2 w	Var.	Comp.	20%	311-125
R54		100 k	1/2 w	Fixed	Comp.	10%	302-104
R62		1 meg	1/2 w	Fixed	Comp.	10%	302-105
R65		470 k	1/2 w	Fixed	Comp.	10%	302-474
R67**		100 k	2 w	Var.	Comp.	20%	311-096
R68		22 k	1/2 w	Fixed	Comp.	10%	302-223
R69		470 k	1/2 w	Fixed	Comp.	10%	302-474
R70		56 k	1/2 w	Fixed	Comp.	10%	302-563
R72		100 Ω	1/2 w	Fixed	Comp.	10%	302-101
R73		100 Ω	1/2 w	Fixed	Comp.	10%	302-101
R74	20420-up	47 Ω	1/2 w	Fixed	Comp.	10%	302-470
R75		33 k	2 w	Fixed	Comp.	10%	306-333
R76	20420-up	47 Ω	1/2 w	Fixed	Comp.	10%	302-470
R78		500 Ω	.2 w	Var.	Comp.	20%	311-066
R79		33 k	2 w	Fixed	Comp.	10%	306-333

*Concentric with R110 and SW110. Furnished as a unit.

**Concentric with R210 and SW210. Furnished as a unit.

Resistors (continued)

							Tektronix Part Number
R81		220 k	1/2 w	Fixed	Comp.	10%	302-224
R82		220 k	1/2 w	Fixed	Comp.	10%	302-224
R83		100 Ω	1/2 w	Fixed	Comp.	10%	302-101
R84		1.5 k	1/2 w	Fixed	Comp.	10%	302-152
R85	20001-21295	1.8 k	1/2 w	Fixed	Comp.	5%	Use 301-152
R85	21296 up	1.5 k	1/2 w	Fixed	Comp.	5%	301-152
R87		100 k	1/2 w	Fixed	Comp.	10%	302-104
R88		270 k	1/2 w	Fixed	Comp.	10%	302-274
R90	101-33014	1.2 meg	1/2 w	Fixed	Comp.	10%	Use 302-225
R90	33015-up	2.2 meg	1/2 w	Fixed	Comp.	10%	302-225
R91		100 Ω	1/2 w	Fixed	Comp.	10%	302-101
R93		1.2 k	1/2 w	Fixed	Comp.	10%	302-122
R96		33 k	2 w	Fixed	Comp.	10%	306-333
R101		1 k	1/2 w	Fixed	Comp.	10%	302-102
R102		22 k	1/2 w	Fixed	Comp.	10%	302-223
R103		22 meg	1/2 w	Fixed	Comp.	10%	302-226
R105		390 k	1/2 w	Fixed	Comp.	10%	302-394
R106		1 meg	1/2 w	Fixed	Comp.	10%	302-105
R107		47 Ω	1/2 w	Fixed	Comp.	10%	302-470
R109		220 k	1/2 w	Fixed	Comp.	10%	302-224
R110*		100 k	2 w	Var.	Comp.	20%	311-096
R111	20001-25639	100 k	.2 w	Var.	Comp.	20%	Use 311-219
R111	25640-up	200 k	.2 w	Var.	Comp.	20%	311-219
R114		470 k	1/2 w	Fixed	Comp.	5%	301-474
R115		100 k	1/2 w	Fixed	Comp.	5%	301-104
R116		180 k	1/2 w	Fixed	Comp.	5%	301-184
R121		47 Ω	1/2 w	Fixed	Comp.	10%	302-470
R122		68 k	1 w	Fixed	Comp.	10%	304-683
R123		270 k	1/2 w	Fixed	Comp.	10%	302-274
R124		470 k	1/2 w	Fixed	Comp.	10%	302-474
R125		50 k	1/2 w	Var.	Comp.	20%	311-023
R126		100 k	1/2 w	Fixed	Comp.	10%	302-104
R127		47 Ω	1/2 w	Fixed	Comp.	10%	302-470
R128		12 k	1/2 w	Fixed	Comp.	10%	302-123
R129		10 k	1/2 w	Fixed	Comp.	10%	302-103
R130		22 k	2 w	Fixed	Comp.	10%	306-223
R131		1 k	1/2 w	Fixed	Comp.	10%	302-102
R132		47 Ω	1/2 w	Fixed	Comp.	10%	302-470
R134**		6 k	Manufactured by Tektronix				310-555
R137		47 Ω	1/2 w	Fixed	Comp.	10%	302-470
R138		47 Ω	1/2 w	Fixed	Comp.	10%	302-470
R141		33 k	1 w	Fixed	Prec.	1%	310-070
R143		30 k	1 w	Fixed	Prec.	1%	310-072
R144		8 k	5 w	Fixed	WW	5%	308-053
R146		47 Ω	1/2 w	Fixed	Comp.	10%	302-470
R147		1 k	1/2 w	Fixed	Comp.	10%	302-102
R148		47 k	1/2 w	Fixed	Comp.	10%	302-473
R150		270 Ω	1/2 w	Fixed	Comp.	10%	302-271
R151		68 k	1/2 w	Fixed	Comp.	5%	301-683
R152		1 meg	1/2 w	Fixed	Comp.	5%	301-105
R153		10 k	1/2 w	Fixed	Comp.	10%	302-103

* Concentric with R17 and Ganged with SW110. Furnished as a unit.

** Center tap.

Resistors (continued)

							Tektronix Part Number
R155		1.8 meg	1/2 w	Fixed	Comp.	10%	302-185
R156		1 meg	1/2 w	Fixed	Comp.	10%	302-105
R157		470 k	1/2 w	Fixed	Comp.	10%	302-474
R158		1 k	1/2 w	Fixed	Comp.	10%	302-102
R159		3.3 k	2 w	Fixed	Comp.	10%	306-332
R160A		100 k	1/2 w	Fixed	Prec.	1%	309-045
R160B		200 k	1/2 w	Fixed	Prec.	1%	309-051
R160C		500 k	1/2 w	Fixed	Prec.	1%	309-003
R160D		1 meg	1/2 w	Fixed	Prec.	1%	309-014
R160E		2 meg	1/2 w	Fixed	Prec.	1%	309-023
R160F		5 meg	1/2 w	Fixed	Prec.	1%	309-087
R160G		10 meg	1 w	Fixed	Prec.	1%	310-107
R160H		10 meg	1 w	Fixed	Prec.	1%	310-107
R160J		30 meg	2 w	Fixed	Prec.	1%	310-505
R160T	24140-up	56 k	1 w	Fixed	Comp.	10%	304-563
R160V	24140-up	1 meg	1/2 w	Fixed	Comp.	10%	302-105
R160W		100 k	1/2 w	Fixed	Comp.	10%	302-104
R160X		10 k	1/2 w	Fixed	Comp.	10%	302-103
R160Y		20 k	2 w	Var.	WW	10%	311-108
R160Z		500 Ω	.2 w	Var.	Comp.	20%	311-066
R164		22 k	2 w	Fixed	Comp.	10%	306-223
R165		22 k	2 w	Fixed	Comp.	10%	306-223
R166		22 k	2 w	Fixed	Comp.	10%	306-223
R167		1.5 meg	1/2 w	Fixed	Comp.	10%	302-155
R168		47 k	1/2 w	Fixed	Comp.	10%	302-473
R171		47 Ω	1/2 w	Fixed	Comp.	10%	302-470
R172		47 Ω	1/2 w	Fixed	Comp.	10%	302-470
R173		470 Ω	1/2 w	Fixed	Comp.	10%	302-471
R174		8 k	5 w	Fixed	WW	5%	308-053
R176		2 k	2 w	Var.	Comp.		311-008
R178		4 k	5 w	Fixed	WW	5%	308-051
R180A		470 k	1/2 w	Fixed	Comp.	10%	302-474
R180B		4.7 meg	1/2 w	Fixed	Comp.	10%	302-475
R181		4.7 meg	1/2 w	Fixed	Comp.	10%	302-475
R183		47 Ω	1/2 w	Fixed	Comp.	10%	302-470
R186		47 Ω	1/2 w	Fixed	Comp.	10%	302-470
R187		47 Ω	1/2 w	Fixed	Comp.	10%	302-470
R189		56 k	2 w	Fixed	Comp.	10%	306-563
R190		47 k	1/2 w	Fixed	Comp.	10%	302-473
R191	20001-24139	120 k	1/2 w	Fixed	Comp.	10%	Use 301-114
R191	24140-up	110 k	1/2 w	Fixed	Comp.	5%	301-114
R192		47 Ω	1/2 w	Fixed	Comp.	10%	302-470
R193		47 Ω	1/2 w	Fixed	Comp.	10%	302-470
R194		4.7 k	1 w	Fixed	Comp.	10%	304-472
R196		100 k	1/2 w	Fixed	Comp.	10%	302-104
R199		100 k	1 w	Fixed	Comp.	10%	304-104
R210*		100 k	2 w	Var.	Comp.	20%	311-096
R211	20001-25639	200 k	2 w	Var.	Comp.	20%	Use 311-219
	25640-up	100 k	.5 w	Var.	Comp.	20%	Use 311-110
R214		100 k	1/2 w	Fixed	Comp.	10%	302-104

* Concentric with R67 and SW210. Furnished as a unit.

Resistors (continued)

Tektronix
Part Number

R215		27 k	1/2 w	Fixed	Comp.	5%	301-273
R216		39 k	1/2 w	Fixed	Comp.	5%	301-393
R221		100 Ω	1/2 w	Fixed	Comp.	10%	302-101
R230		22 k	1 w	Fixed	Comp.	10%	304-223
R232		100 Ω	1/2 w	Fixed	Comp.	10%	302-101
R233		5.6 k	1/2 w	Fixed	Prec.	1%	309-132
R234		5 k	1/2 w	Fixed	Prec.	1%	309-159
R235		270 k	1/2 w	Fixed	Comp.	10%	302-274
R237		100 Ω	1/2 w	Fixed	Comp.	10%	302-101
R241		33 k	1 w	Fixed	Prec.	1%	310-070
R243		30 k	1 w	Fixed	Prec.	1%	310-072
R244		15 k	5 w	Fixed	WW	5%	308-108
R246		100 Ω	1/2 w	Fixed	Comp.	10%	302-101
R247		2.2 k	1/2 w	Fixed	Comp.	10%	302-222
R248		47 k	1/2 w	Fixed	Comp.	10%	302-473
R249		8.2 k	1/2 w	Fixed	Comp.	10%	302-822
R250		2.7 k	1/2 w	Fixed	Comp.	10%	302-272
R260A		404 k	1/2 w	Fixed	Prec.	1/4%	312-567
R260B		606 k	1/2 w	Fixed	Prec.	1/4%	312-568
R260C		1.01 meg	1/2 w	Fixed	Prec.	1/4%	312-571
R260D		4.04 meg	1/2 w	Fixed	Prec.	1/4%	312-575
R260E		6.06 meg	1/2 w	Fixed	Prec.	1/4%	312-576
R260F		10.1 meg	1/2 w	Fixed	Prec.	1/4%	312-577
R264		220 k	2 w	Fixed	Comp.	10%	306-224
R267		1.5 meg	1/2 w	Fixed	Comp.	10%	302-155
R268		100 k	1/2 w	Fixed	Comp.	10%	302-104
R271		100 Ω	1/2 w	Fixed	Comp.	10%	302-101
R274		15 k	2 w	Fixed	Comp.	10%	306-153
R276	20001-20319 20320-up	10 k	2 w	Var.	Comp.	10%	Use 311-016
R276		10 k	2 w	Var.	Comp.		311-016
R277		Selected					
R278		Selected					
R279		12 k	2 w	Fixed	Comp.	10%	306-123
R280		1.2 meg	1/2 w	Fixed	Comp.	10%	302-125
R281		4.7 meg	1/2 w	Fixed	Comp.	10%	302-475
R282		1 k	1/2 w	Fixed	Comp.	10%	302-102
R283	20001-21879 21880-up	100 Ω	1/2 w	Fixed	Comp.	10%	Use 302-102
R283		1 k	1/2 w	Fixed	Comp.	10%	302-102
R291		100 Ω	1/2 w	Fixed	Comp.	10%	302-101
R293		82 k	2 w	Fixed	Comp.	10%	306-823
R295		39 k	1/2 w	Fixed	Comp.	10%	302-393
R296		100 k	1/2 w	Fixed	Comp.	10%	302-104
R297		100 Ω	1/2 w	Fixed	Comp.	10%	302-101
R299		10 k	1/2 w	Fixed	Comp.	10%	302-103
R300		47 Ω	1/2 w	Fixed	Comp.	10%	302-470
R301C		900 k	1/2 w	Fixed	Prec.	1%	309-111
R301E		111 k	1/2 w	Fixed	Prec.	1%	309-046
R303		1 meg	1/2 w	Fixed	Comp.	10%	302-105
R311		1 k	1/2 w	Fixed	Comp.	10%	302-102
R313		33 k	2 w	Fixed	Comp.	10%	306-333

Resistors (continued)

Tektronix
Part Number

R314	20001-21879	10 k	2 w	Var.	Comp.	10%	Use 311-112	
R314	21880-up	15 k	2 w	Var.	Comp.	20%	311-112	
R315		33 k	2 w	Fixed	Comp.	10%	306-333	
R317		100 k	2 w	Var.	Comp.	20%	311-026	
R319		220 k	1/2 w	Fixed	Comp.	10%	302-224	
R320		3.3 k	1/2 w	Fixed	Comp.	10%	302-332	
R321		100 Ω	1/2 w	Fixed	Comp.	10%	302-101	
R324	20001-21879	22 k	2 w	Fixed	Comp.	10%	Use 306-273	
R324	21880-up	27 k	2 w	Fixed	Comp.	10%	306-273	
R330		1.5 meg	1/2 w	Fixed	Prec.	1%	309-017	
R332		3.5 meg	1/2 w	Fixed	Prec.	1%	309-086	
R333*		100 k	2 w	Var.	Comp.	20%	311-149	
R336		12.1 meg	1/2 w	Fixed	Prec.	1%	309-268	
R338*		200 k	2 w	Var.	Comp.	20%	311-149	
R340		2.2 k	1/2 w	Fixed	Comp.	10%	302-222	
R341		100 Ω	1/2 w	Fixed	Comp.	10%	302-101	
R345		100 k	1 w	Fixed	Comp.	10%	304-104	
R347		100 k	1/2 w	Fixed	Comp.	10%	302-104	
R348		50 k	.2 w	Var.	Comp.	20%	311-125	
R349	20001-23839	111 k	1/2 w	Fixed	Prec.	1%	Use 309-091	
R349	23840-up	120 k	1/2 w	Fixed	Prec.	1%	309-091	
R351		100 Ω	1/2 w	Fixed	Comp.	10%	302-101	
R353		100 k	1 w	Fixed	Comp.	10%	304-104	
R355		400 k	1 w	Fixed	Prec.	1%	310-094	
R356		400 k	1 w	Fixed	Prec.	1%	310-094	
R357	20001-28589	22 k	1/2 w	Fixed	Comp.	10%	Use 304-223	
R357	28590-up	22 k	1 w	Fixed	Comp.	10%	304-223	
R358	20001-24139	10 k	2 w	Var.	Comp.		Use 311-018	
R358	24140-up	20 k	2 w	Var.	Comp.		311-018	
R361		47 Ω	1/2 w	Fixed	Comp.	10%	302-470	
R364		6—25 k Manufactured by Tektronix						310-506
R366		47 Ω	1/2 w	Fixed	Comp.	10%	302-470	
R373		2.2 k	1 w	Fixed	Comp.	10%	304-222	
R375		2 k	2 w	Var.	Comp.		311-008	
R376		2.2 k	1 w	Fixed	Comp.	10%	304-222	
R377		6 k	5 w	Fixed	WW	5%	308-052	
R380		100 Ω	1/2 w	Fixed	Comp.	10%	302-101	
R381		47 Ω	1/2 w	Fixed	Comp.	10%	302-470	
R384		6—30 k Manufactured by Tektronix						310-507
R386		100 Ω	1/2 w	Fixed	Comp.	10%	302-101	
R387		39 k	2 w	Fixed	Comp.	10%	306-393	
R388		39 k	2 w	Fixed	Comp.	10%	306-393	
R390		2.2 k	1/2 w	Fixed	Comp.	10%	302-222	
R391		47 Ω	1/2 w	Fixed	Comp.	10%	302-470	
R393		390 Ω	1/2 w	Fixed	Comp.	10%	302-391	
R396		470 k	1/2 w	Fixed	Comp.	10%	302-474	
R397		820 k	1/2 w	Fixed	Comp.	10%	302-824	
R398		820 k	1/2 w	Fixed	Comp.	10%	302-824	
R399		470 k	1/2 w	Fixed	Comp.	10%	302-474	
R410		1 meg	1/2 w	Fixed	Comp.	10%	302-105	
R411		100 Ω	1/2 w	Fixed	Comp.	10%	302-101	

*R333 and R338 are concentric.

Resistors (continued)

							Tektronix Part Number
R415		47 k	1/2 w	Fixed	Comp.	10%	302-473
R416		12 k	1/2 w	Fixed	Comp.	10%	302-123
R421		100 Ω	1/2 w	Fixed	Comp.	10%	302-101
R424		10 k	1/2 w	Fixed	Comp.	10%	302-103
R425		100 k	1/2 w	Fixed	Comp.	10%	302-104
R426		47 k	1/2 w	Fixed	Comp.	10%	302-473
R427		100 Ω	1/2 w	Fixed	Comp.	10%	302-101
R428		10 k	1/2 w	Fixed	Comp.	10%	302-103
R431		10 k	5 w	Fixed	WW	5%	308-054
R432		10 k	2 w	Var.	WW		311-015
R433		30 k	3 w	Var.	helipot	.1%	311-022
R434		100 k	1/2 w	Fixed	Comp.	10%	302-104
R436		2 k	2 w	Var.	WW	5%	311-141
R437		15 k	5 w	Fixed	WW	5%	308-108
R441		100 Ω	1/2 w	Fixed	Comp.	10%	302-101
R443		2.7 k	1/2 w	Fixed	Comp.	10%	302-272
R444		95 k	1/2 w	Fixed	Prec.	1%	309-044
R446		150 k	1/2 w	Fixed	Prec.	1%	309-049
R447		39 k	2 w	Fixed	Comp.	10%	306-393
R451		100 Ω	1/2 w	Fixed	Comp.	10%	302-101
R453		3.3 k	1/2 w	Fixed	Comp.	10%	302-332
R454		10 k	1/2 w	Fixed	Comp.	10%	302-103
R455		270 k	1/2 w	Fixed	Comp.	10%	302-274
R456		100 Ω	1/2 w	Fixed	Comp.	10%	302-101
R457		47 Ω	1/2 w	Fixed	Comp.	10%	302-470
R458		1 k	1/2 w	Fixed	Comp.	10%	302-102
R593*		30 k	10 w	Fixed	WW	5%	308-027
R600		12 Ω	1 w	Fixed	Comp.	10%	304-120
R601		30 Ω	3 w	Fixed	WW	5%	308-142
R602		50 Ω	2 w	Var.	WW	5%	311-055
R604	X27730-up	6 k	5 w	Fixed	WW	5%	308-052
R608		33 k	1/2 w	Fixed	Comp.	10%	302-333
R610		100 k	1/2 w	Fixed	Comp.	10%	302-104
R615		68 k	1 w	Fixed	Prec.	1%	310-054
R616		10 k	2 w	Var.	WW	20%	311-015
R617		50 k	1 w	Fixed	Prec.	1%	310-086
R618		100 k	1/2 w	Fixed	Comp.	10%	302-104
R621		1 k	1/2 w	Fixed	Comp.	10%	302-102
R623		470 k	1/2 w	Fixed	Comp.	10%	302-474
R625		100 k	1/2 w	Fixed	Comp.	10%	302-104
R628		2.7 meg	1/2 w	Fixed	Comp.	10%	302-275
R629		2.7 meg	1/2 w	Fixed	Comp.	10%	302-275
R633		1 meg	1/2 w	Fixed	Comp.	10%	302-105
R635		15 k	1 w	Fixed	Comp.	10%	304-153
R636		15 k	1 w	Fixed	Comp.	10%	304-153
R637		150 k	1/2 w	Fixed	Comp.	10%	302-154
R638		27 k	1/2 w	Fixed	Comp.	10%	302-273
R639		68 k	1/2 w	Fixed	Comp.	10%	302-683
R640		10 Ω	1 w	Fixed	Comp.	10%	304-100
R641		10 Ω	1 w	Fixed	Comp.	10%	304-100
R643		1 k	1/2 w	Fixed	Comp.	10%	302-102

* Cathode resistor for V1223.

Resistors (continued)

							Tektronix Part Number
R644		1 k	1/2 w	Fixed	Comp.	10%	302-102
R647	20,001-up	750 Ω	25 w	Fixed	WW	5%	308-147
R648		10 Ω	1/2 w	Fixed	Comp.	10%	302-100
R650		333 k	1 w	Fixed	Prec.	1%	310-056
R651		490 k	1 w	Fixed	Prec.	1%	310-057
R663		1.5 meg	1/2 w	Fixed	Comp.	10%	302-155
R667		680 k	1/2 w	Fixed	Comp.	10%	302-684
R668		47 k	1/2 w	Fixed	Comp.	10%	302-473
R669		39 k	1/2 w	Fixed	Comp.	10%	302-393
R670		10 Ω	2 w	Fixed	Comp.	5%	306-100
R675	20001-20319	750 Ω	10 w	Fixed	WW	10%	308-016
R675	20320-up	750 Ω	25 w	Fixed	WW	5%	308-147
R676		1.5 k	10 w	Fixed	WW	5%	308-055
R677	20001-20139	1.25 k	25 w	Fixed	WW	5%	308-102
R677	20140-up	1.5 k	25 w	Fixed	WW	5%	308-040
R680		333 k	1 w	Fixed	Prec.	1%	310-056
R681		220 k	1 w	Fixed	Prec.	1%	310-055
R682		120 k	1/2 w	Fixed	Comp.	10%	302-124
R683		1 k	1/2 w	Fixed	Comp.	10%	302-102
R685		82 k	1 w	Fixed	Comp.	10%	304-823
R686		180 k	1/2 w	Fixed	Comp.	10%	302-184
R688		1.5 meg	1/2 w	Fixed	Comp.	10%	302-155
R689		2.2 meg	1/2 w	Fixed	Comp.	10%	302-225
R693		1.5 meg	1/2 w	Fixed	Comp.	10%	302-155
R697		1 meg	1/2 w	Fixed	Comp.	10%	302-105
R698		270 k	1/2 w	Fixed	Comp.	10%	302-274
R699		56 k	1/2 w	Fixed	Comp.	10%	302-563
R700		10 Ω	2 w	Fixed	Comp.	10%	306-100
R710	20001-27049	236 k	1 w	Fixed	WW	1%	308-083
R710	27050-up	237 k	1 w	Fixed	Prec.	1%	310-124
R711		100 k	1/2 w	Fixed	Prec.	1%	Use 309-334
R712		150 k	1/2 w	Fixed	Comp.	10%	302-154
R723		1.5 meg	1/2 w	Fixed	Comp.	10%	302-155
R727		1 meg	1/2 w	Fixed	Comp.	10%	302-105
R728		560 k	1/2 w	Fixed	Comp.	10%	302-564
R729		47 k	1/2 w	Fixed	Comp.	10%	302-473
R730		10 Ω	1 w	Fixed	Comp.	10%	304-100
R731		10 Ω	1 w	Fixed	Comp.	10%	304-100
R732		82 k	2 w	Fixed	Comp.	10%	306-823
R734		1 k	1/2 w	Fixed	Comp.	10%	302-102
R736		1.5 k	25 w	Fixed	WW	5%	308-040
R737		2 k	25 w	Fixed	WW	5%	308-065
R740		220 k	1 w	Fixed	Prec.	1%	310-055
R741		720 k	1 w	Fixed	Prec.	1%	310-059
R753		1 meg	1/2 w	Fixed	Comp.	10%	302-105
R757		150 k	1/2 w	Fixed	Comp.	10%	302-154
R758		120 k	1/2 w	Fixed	Comp.	10%	302-124
R759		27 k	1/2 w	Fixed	Comp.	10%	302-273
R760		10 Ω	1/2 w	Fixed	Comp.	10%	302-100

Resistors (continued)

Tektronix
Part Number

R767		3 k	8 w	Fixed	WW	5%	308-113
R780		150 k	1/2 w	Fixed	Comp.	10%	302-154
R785		100 k	1/2 w	Fixed	Comp.	10%	302-104
R801		1 k	1/2 w	Fixed	Comp.	10%	302-102
R802		390 Ω	2 w	Fixed	Comp.	10%	306-391
R803		56 k	2 w	Fixed	Comp.	10%	306-563
R806		100 k	1/2 w	Fixed	Comp.	10%	302-104
R807		1 k	1/2 w	Fixed	Comp.	10%	302-102
R814		470 k	1/2 w	Fixed	Comp.	10%	302-474
R818	X28860-up	1.8 meg	1/2 w	Fixed	Comp.	10%	302-185
R819	X28860-up	1.8 meg	1/2 w	Fixed	Comp.	10%	302-185
R820		47 k	1/2 w	Fixed	Comp.	10%	302-473
R822	X20130-up	33 k	1/2 w	Fixed	Comp.	10%	302-333
R824		4.7 meg	2 w	Fixed	Comp.	10%	306-475
R825		4.7 meg	2 w	Fixed	Comp.	10%	306-475
R826		1 meg	2 w	Var.	Comp.		311-041
R827	X20001-23289	100 k	1/2 w	Fixed	Comp.	10%	302-104
R827	23290-up	33 k	1/2 w	Fixed	Comp.	10%	302-333
R828		1 meg	1/2 w	Fixed	Comp.	10%	302-105
R829	X28860-up	22 k	1/2 w	Fixed	Comp.	10%	302-223
R836		1 meg	1/2 w	Fixed	Comp.	10%	302-105
R840		2 meg	2 w	Var.	Comp.		311-042
R841		2.2 meg	1/2 w	Fixed	Comp.	10%	302-225
R842		4.7 meg	1/2 w	Fixed	Comp.	10%	302-475
R843		4.7 meg	1/2 w	Fixed	Comp.	10%	302-475
R844		4.7 meg	1/2 w	Fixed	Comp.	10%	302-475
R845		10 k	1/2 w	Fixed	Comp.	10%	302-103
R847		27 k	1/2 w	Fixed	Comp.	10%	302-273
R848		1 meg	1/2 w	Fixed	Comp.	10%	302-105
R853		2.2 meg	2 w	Fixed	Comp.	10%	306-225
R854		2.2 meg	2 w	Fixed	Comp.	10%	306-225
R856		2 meg	2 w	Var.	Comp.		311-043
R857		1 meg	2 w	Fixed	Comp.	10%	306-105
R861		100 k	2 w	Var.	Comp.	20%	311-026
R862		100 k	1/2 w	Fixed	Comp.	10%	302-104
R863		150 k	1/2 w	Fixed	Comp.	10%	302-154
R864		50 k	2 w	Var.	Comp.		311-023
R870		150 k	1/2 w	Fixed	Comp.	10%	302-154
R871		2.7 meg	1/2 w	Fixed	Comp.	10%	302-275
R872		1 k	1/2 w	Fixed	Comp.	10%	302-102
R874		3.9 meg	1/2 w	Fixed	Comp.	10%	302-395
R875		68 k	1/2 w	Fixed	Comp.	10%	302-683
R876		1 k	1/2 w	Fixed	Comp.	10%	302-102
R878		33 k	1 w	Fixed	Comp.	10%	304-333
R879		10 k	2 w	Var.	Comp.		311-016
R880		100 k	1/2 w	Fixed	Comp.	10%	302-104
R883		100 Ω	1/2 w	Fixed	Comp.	10%	302-101
R885		9.5 k	1/2 w	Fixed	Prec.	1%	309-121
R886		6.375 k	1/2 w	Fixed	Prec.	1%	309-119
R887		2.1 k	1/2 w	Fixed	Prec.	1%	309-117
R888		1.025 k	1/2 w	Fixed	Prec.	1%	309-116
R889		610 Ω	1/2 w	Fixed	Prec.	1%	309-113

Resistors (continued)

							Tektronix Part Number
R890		200 Ω	$\frac{1}{2}$ w	Fixed	Prec.	1%	309-073
R891		100 Ω	$\frac{1}{2}$ w	Fixed	Prec.	1%	309-112
R892		60 Ω	$\frac{1}{2}$ w	Fixed	Prec.	1%	309-067
R893		40 Ω	$\frac{1}{2}$ w	Fixed	Prec.	1%	309-066
R896		100 k	$\frac{1}{2}$ w	Fixed	Prec.	1%	309-045
R897		100 Ω	$\frac{1}{2}$ w	Fixed	Prec.	1%	309-112
R898		100 Ω	$\frac{1}{2}$ w	Fixed	Comp.	10%	302-101
R899		.25 Ω	1 w	Fixed	WW	10%	308-090
R1003		100 Ω	1 w	Fixed	Comp.	10%	304-101
R1005		100 Ω	1 w	Fixed	Comp.	10%	304-101
R1007		47 Ω	$\frac{1}{2}$ w	Fixed	Comp.	10%	302-470
R1008		47 Ω	$\frac{1}{2}$ w	Fixed	Comp.	10%	302-470
R1009		100 Ω	1 w	Fixed	Comp.	10%	304-101
R1011		27 Ω	$\frac{1}{2}$ w	Fixed	Comp.	10%	302-270
R1013		910 Ω	2 w	Fixed	Comp.	5%	305-911
R1014		500 Ω	$\frac{1}{2}$ w	Fixed	Prec.	1%	309-179
R1016		3 k	5 w	Fixed	WW	5%	308-062
R1017		10 k	8 w	Fixed	WW	5%	308-126
R1018		330 Ω	$\frac{1}{2}$ w	Fixed	Comp.	10%	302-331
R1019		470 k	$\frac{1}{2}$ w	Fixed	Comp.	10%	302-474
R1021		27 Ω	$\frac{1}{2}$ w	Fixed	Comp.	10%	302-270
R1024		500 Ω	$\frac{1}{2}$ w	Fixed	Prec.	1%	309-179
R1026		330 Ω	$\frac{1}{2}$ w	Fixed	Comp.	10%	302-331
R1027		200 Ω	2 w	Var.	Comp.		311-004
R1029		470 k	$\frac{1}{2}$ w	Fixed	Comp.	10%	302-474
R1031		2.2 k	1 w	Fixed	Comp.	10%	304-222
R1033		2.5 k	5 w	Fixed	WW	5%	308-127
R1036		27 k	2 w	Fixed	Comp.	10%	306-273
R1039		33 Ω	$\frac{1}{2}$ w	Fixed	Comp.	10%	302-330
R1046		27 k	2 w	Fixed	Comp.	10%	306-273
R1049		33 Ω	$\frac{1}{2}$ w	Fixed	Comp.	10%	302-330
R1052		470 k	$\frac{1}{2}$ w	Fixed	Comp.	10%	302-474
R1054		167 Ω	5 w	Fixed	WW	5%	308-104
R1055		4.5 k	5 w	Fixed	WW	5%	308-066
R1062		470 k	$\frac{1}{2}$ w	Fixed	Comp.	10%	302-474
R1071		600 Ω	5 w	Pair matched within $\frac{1}{2}$ %			312-587
R1073		600 Ω	5 w				
R1075		220 Ω	$\frac{1}{4}$ w	Fixed	Comp.	10%	316-221
R1077		47 Ω	$\frac{1}{4}$ w	Fixed	Comp.	10%	316-470
R1078		150 Ω	$\frac{1}{4}$ w	Fixed	Comp.	10%	316-151
R1080	20001-28859	150 k	$\frac{1}{2}$ w	Fixed	Comp.	10%	302-154
R1080	28860-up	100 k	$\frac{1}{2}$ w	Fixed	Comp.	10%	302-104
R1081		330 k	$\frac{1}{2}$ w	Fixed	Comp.	10%	302-334
R1083	20001-28859	390 k	$\frac{1}{2}$ w	Fixed	Comp.	10%	302-394
R1083	28860-up	330 k	$\frac{1}{2}$ w	Fixed	Comp.	10%	302-334
R1084		680 k	$\frac{1}{2}$ w	Fixed	Comp.	10%	302-684
R1085		1 meg	$\frac{1}{4}$ w	Fixed	Comp.	10%	316-105
R1087	20001-28859	390 k	$\frac{1}{2}$ w	Fixed	Comp.	10%	302-394
R1087	28860-up	330 k	$\frac{1}{2}$ w	Fixed	Comp.	10%	302-334
R1089		1 meg	$\frac{1}{4}$ w	Fixed	Comp.	10%	316-105
R1090	20001-29259	8.2 k	Selected			10%	316-822
R1090	29260-up	6.8 k	Selected				316-682
R1091		250 k	2 w	Var.	Comp.		311-061
R1092		47 k	$\frac{1}{2}$ w	Fixed	Comp.	10%	302-473

Resistors (continued)

Tektronix
Part Number

R1093	X29960-up	56 k	1 w	Fixed	Comp.	10%	304-563
R1094		68 k	1/10 w	Fixed	Comp.	10%	307-006
R1095	20,001-29259	8.2 k	Selected			10%	316-822
R1095	29260-up	6.8 k	Selected			10%	316-682
R1097		47 k	1/2 w	Fixed	Comp.	10%	302-473
R1099		68 k	1/10 w	Fixed	Comp.	10%	307-006
R1102		470 k	1/2 w	Fixed	Comp.	10%	302-474
R1105		4.5 k	5 w	Fixed	WW	5%	308-066
R1112		470 k	1/2 w	Fixed	Comp.	10%	302-474
R1122		470 k	1/2 w	Fixed	Comp.	10%	302-474
R1125		4.5 k	5 w	Fixed	WW	5%	308-066
R1132		470 k	1/2 w	Fixed	Comp.	10%	302-474
R1142		470 k	1/2 w	Fixed	Comp.	10%	302-474
R1145		4.5 k	5 w	Fixed	WW	5%	308-066
R1152		470 k	1/2 w	Fixed	Comp.	10%	302-474
R1162		470 k	1/2 w	Fixed	Comp.	10%	302-474
R1165		4.5 k	5 w	Fixed	WW	5%	308-066
R1172		470 k	1/2 w	Fixed	Comp.	10%	302-474
R1182		470 k	1/2 w	Fixed	Comp.	10%	302-474
R1185		4.5 k	5 w	Fixed	WW	5%	308-066
R1192		470 k	1/2 w	Fixed	Comp.	10%	302-474
R1202		470 k	1/2 w	Fixed	Comp.	10%	302-474
R1205		4.5 k	5 w	Fixed	WW	5%	308-066
R1206		360 Ω	1/2 w	Fixed	Comp.	5%	301-361
R1208		12 k	8 w	Fixed	WW	5%	308-069
R1212		470 k	1/2 w	Fixed	Comp.	10%	302-474
R1216		360 Ω	1/2 w	Fixed	Comp.	5%	301-361
R1218		1 k	5 w	Fixed	WW	5%	308-106
R1221		100 Ω	1/2 w	Fixed	Comp.	10%	302-101
R1223		4.7 k	2 w	Fixed	Comp.	10%	306-472
R1226		100 Ω	1/2 w	Fixed	Comp.	10%	302-101
R1227		15 k	2 w	Fixed	Comp.	10%	306-153
R1228		1 meg	1/2 w	Fixed	Comp.	10%	302-105
R1229		1 k	1/2 w	Fixed	Comp.	10%	302-102
R1301		1 k	1/2 w	Fixed	Comp.	10%	302-102
R1302		1 k	1/2 w	Fixed	Comp.	10%	302-102
R1303		1 k	1/2 w	Fixed	Comp.	10%	302-102
R1304		1 k	1/2 w	Fixed	Comp.	10%	302-102
R1305		1 k	1/2 w	Fixed	Comp.	10%	302-102
R1306		1 k	1/2 w	Fixed	Comp.	10%	302-102
R1307		1 k	1/2 w	Fixed	Comp.	10%	302-102
R1308		1 k	1/2 w	Fixed	Comp.	10%	302-102

Switches

WIRED UNWIRED

SW10A	TRIGGER SLOPE	}	TIME BASE A	*262-174 260-099
SW10B	TRIGGERING MODE			
SW60A*	TRIGGER SLOPE	}	TIME BASE B	*262-209 260-261
SW60B*	TRIGGERING MODE			
SW103	RESET, push button, SPST			260-017

*SW60A and SW60B are concentric controls.

Switches (continued)

			Tektronix Part Number	
			Wired	Unwired
SW110		PRESET, (TIME BASE A)		† 311-096
SW160	20001-20129	TIME/CM (TIME BASE A)	*262-206	260-230
SW160	20130-up	TIME/CM (TIME BASE A)	*262-245	260-230
SW210		PRESET (TIME BASE B)		‡ 311-096
SW260		TIME/CM OR DELAY TIME (TIME BASE B)	*262-208	260-260
SW301**		HORIZONTAL DISPLAY (FRONT)	*262-210	260-262
SW347A**		HORIZONTAL DISPLAY {	*262-312	*260-263
SW347B***		5X MAGNIFIER }		
SW601		POWER ON, SPST		260-134
SW848		CRT CATHODE SELECTOR, SPDT		260-209
SW870		AMPLITUDE CALIBRATOR	*262-207	260-253

Thermal Cutout

TK601		133° Thermo Cutout		260-208
-------	--	--------------------	--	---------

Transformers

T601		Power		120-120
T801		High Voltage		120-036

Relays

K600		6N045T 45 sec. thermal time delay 6.3 v		148-002
K601	20001-27729	4PDT, 6.3 v		148-004
K601	27730-up	DC Relay Coil, 2000 Ω		148-016

Vacuum Tubes

V24		6DJ8		154-187
V45		6DJ8		154-187
V74		6DJ8		154-187
V95		6DJ8		154-187
V114		6AU6		154-022
V125		6AU6		154-022
V133		6DJ8		154-187
V135		6DJ8		154-187
V145		12BY7		154-047
V152		6AL5		154-016
V154		6DJ8		154-187
V161		6CL6		154-031
V173		6DJ8		154-187

**SW301 and SW347A are ganged.

***SW347B is concentric with SW301 and SW347A.

†Ganged with R110, concentric with R17. Furnished as a unit.

‡ Concentric with R67, R210. Furnished as a unit.

Vacuum Tubes (continued)

		Tektronix Part Number
V183	6DJ8	154-187
V193	6DJ8	154-187
V233	6DJ8	154-187
V235	6DJ8	154-187
V245	6AU6	154-022
V252	12AL5	154-038
V261	12AU6	154-040
V283	6DJ8	154-187
V293	6DJ8	154-187
V314	6DJ8	154-187
V343	6DJ8	154-187
V364	6DJ8	154-187
V384	6DJ8	154-187
V398	6CL6	154-031
V414	6AU6	154-022
V424	6AU6	154-022
V428	6DJ8	154-187
V445	6DJ8	154-187
V609	5651	154-052
V624	12AX7	154-043
V627	12B4	154-044
V634	6AU6	154-022
V637	12B4	154-044
V647	12B4	154-044
V664	6AU6	154-022
V677	6080	154-056
V684	12AX7	154-043
V694	6AU6	154-022
V724	6AU6	154-022
V737	6080	154-056
V754	6AU6	154-022
V767	12B4	154-044
V800	6AU5	154-021
V814	12AU7	154-041
V822	5642	154-051
V832	5642	154-051
V842	5642	154-051
V852	5642	154-051
V859	T543/P2	*154-175
V862	5642	154-051
V875	6AU6	154-022
V885	12AU7	154-041
V1014†	12BY7 Selected	157-053
V1024†	12BY7 Selected	157-053
V1033	6DJ8	154-187
V1043	6DJ8	154-187
V1054	8136/6DK6	154-367
V1064	8136/6DK6	154-367
V1084	12AU7	154-041
V1104	8136/6DK6	154-367

Vacuum Tubes (continued)

		Tektronix Part Number
V1114	8136/6DK6	154-367
V1124	8136/6DK6	154-367
V1134	8136/6DK6	154-367
V1144	8136/6DK6	154-367
V1154	8136/6DK6	154-367
V1164	8136/6DK6	154-367
V1174	8136/6DK6	154-367
V1184	8136/6DK6	154-367
V1194	8136/6DK6	154-367
V1204	8136/6DK6	154-367
V1214	8136/6DK6	154-367
V1223	6DJ8	154-187

† V1014 & V1024 furnished as a unit.

Mechanical Parts List Type 545A

	Tektronix Part Number
ADAPTOR, POWER CORD, 3-wire to 2-wire	103-013
ANGLE, FRAME, ALUM., EXT. TOP LEFT 207/16	122-019
ANGLE, FRAME, ALUM., EXT. RT. BOTTOM SN 101-24602	122-050
ANGLE, FRAME, ALUM., EXT. LEFT BOTTOM SN 101-24602	122-051
ANGLE, FRAME, ALUM., EXT. LEFT BOTTOM 207/16 SN 24603-up	122-070
ANGLE, FRAME, ALUM., EXT. RT. BOTTOM 207/16 SN 24603-up	122-071
BAR, ALUM., 3/8 x 107/32 Swivel Support w/4 6-32 tapped holes	381-063
BAR, ALUM., 3/8 x 913/16, Swivel Support	381-064
BAR, ALUM., 3/16 x 1/2 x 13/4, Retaining w/2 8-32 tapped holes	381-073
BAR, ALUM., 1/4 x 1/4 x 117/32, Support, tapped 6-32	381-107
BAR, ALUM., EXT. CHANNEL TOP SUPPORT SN 101-24602	381-121
BAR, ALUM., EXT. CHANNEL TOP SUPPORT 207/16 SN 24603-up	381-149
BASE, ALUM., CRT ROTATOR, BLACK SN 22060-up	432-022
BOLT, CAPTIVE Alum. 3/8 OD x 113/32	214-008
BOLT, SPADE, STEEL, 6-32 x 3/8	214-012
BOLT, SPADE, STEEL, 6-32 x 7/8	214-013
BRACKET, ALUM., .080 x 1 x 11/2 x 1/2	406-022
BRACKET, ALUM., —150 Adj.	406-108
BRACKET, PLASTIC, 13/16 x 11/2, Molded Coil Mtg.	406-175
BRACKET, SP. PHOS. BRONZE, .013 x 3/4 x 21/4 x 5/8	406-239
BRACKET, NYLON MOLDED, .160 x 3/4	406-244
BRACKET, PHOS. BRONZE, 3/4 x 1/2 x 15/16, Ground Clip	406-245
BRACKET, ALUM., .080 x 43/8 x 31/2 x 15/8, CRT Support	406-251
BRACKET, ALUM., .080 x 2 x 51/2 x 5/8, WW Res. Mtg.	406-435
BRACKET, ALUM., .063 x 25/16 x 1 x 11/4, Time/CM Switch	406-449
BRACKET, ALUM., .063 x 27/32 x 15/16 x 7/8, Mag. Switch	406-450
BRACKET, ALUM., .080 x 21/8 x 17/8 x 9/32, Horiz. Disp. Sw.	406-451
BRACKET, ALUM., POT (7)	406-454
BRACKET, ALUM., .063 x 321/32 x 1, Time/CM SN 20960-up	406-497
BUSHING, ALUM., 3/8-32 x 9/16 x .412	358-010
BUSHING, NYLON, for 5-way binding post	358-036
BUSHING, BANANA JACK, BRASS 1/4-32 x 13/32 x .159 ID x .375 OD	358-054
CABLE, HARNESS, F & I	179-061
CABLE, HARNESS, VA	179-179

Mechanical Parts List (continued)

	Tektronix Part Number
CABLE, HARNESS, POWER	179-296
CABLE, HARNESS, RECTIFIER	179-298
CABLE, HARNESS, SWEEP SN 101-23505	179-300
CABLE, HARNESS, DELAY SWEEP #1 SN 101-20420	179-301
CABLE, HARNESS, DELAY SWEEP #1 SN 20421-up	179-371
CABLE, HARNESS, DELAY SWEEP #2 SN 101-26779	179-302
CABLE, HARNESS, DELAY SWEEP #2 SN 26780-up	179-506
CABLE, HARNESS, 110 VOLTS POWER	179-306
CABLE, HARNESS, 110 VOLT RECTIFIER	179-305
CABLE, HARNESS, POWER #2	179-324
CABLE, HARNESS, SWEEP SN 23506-up	179-405
CAM, NYLON 3/8" OD .150 hi.	401-004
CAN, 202-013, 500A Rect. Bracket	202-015
CAP, FUSE, 3 AG	200-015
CHASSIS, DELAY LINE, Horiz. 10"	441-100
CHASSIS, DELAY LINE, Horiz. 8 1/8"	441-114
CHASSIS, DELAY LINE, Vert. 12 1/4"	441-115
CHASSIS, DELAY LINE, Vert.	441-137
CHASSIS, VA	441-219
CHASSIS, F & I	441-142
CHASSIS, POWER	441-238
CHASSIS, SWEEP, Silk Screened	441-240
CHASSIS, DELAY SWEEP	441-242
CLAMP, CABLE, 1/8" Plastic	343-001
CLAMP, CABLE, 3/16" Plastic	343-002
CLAMP, CABLE, 1/4" Plastic	343-003
CLAMP, CABLE, 5/16" Plastic	343-004
CLAMP, CABLE, 7/16" Plastic	343-005
CLAMP, CABLE, 1/2" Plastic	343-006
CLAMP, CABLE, 3/8" Plastic	343-013
CLAMP, STAINLESS STEEL, 27/32 ID w/2 mtg. feet SN 101-22059	343-034
CLAMP, CABLE, 5/16" (half) Plastic	343-042
CLAMP, #20 Wire for Neon Bulbs	343-043
CONNECTOR, CHASSIS MT., 16-contact female	131-018
CONNECTOR, CABLE, CRT PIN	131-049
CONNECTOR, CHASSIS MT., (CALOUT) COAX	131-064

Mechanical Parts List (continued)

	Tektronix Part Number
CONNECTOR, CHASSIS MT., COAX 1-contact female 1/2" D hole	131-081
CONNECTOR, CABLE, 31" ANODE ASS'Y	131-086
CONNECTOR, CHASSIS MT., 3-wire Tekmotor Base, male	131-102
CONNECTOR, BINDING POST ADAPTOR	013-004
CORD, PATCH BANANA PLUG, both ends 18" Red	012-031
CORD, POWER, 16 ga., 8 ft., 3-wire w/male & female, round ground	161-010
COUPLING, 1 long, w/2 tapped holes	376-007
COUPLING, POT WIRE STEEL	376-014
COVER, GRATICULE	200-025
COVER, CRT ANODE & PLATE ASS'Y	200-112
DIAL, DUODIAL w/o brakes	331-022
EYELET, .190-.183 OD tapped barrel	210-601
FAN, ALUM., 7" blade	369-007
FILTER, AIR	378-011
GRATICULE, 5"	331-034
GROMMET, RUBBER 1/4"	348-002
GROMMET, RUBBER 5/16"	348-003
GROMMET, RUBBER 3/8"	348-004
GROMMET, RUBBER 1/2"	348-005
GROMMET, RUBBER 3/4"	348-006
GROMMET, RUBBER 5/8"	348-012
HOLDER, NYLON, NEON, Double molded 7/8 x 1.088	352-006
HOLDER, NYLON, NEON, Bulb, single, black molded 1 1/16 x .90 dia.	352-008
HOLDER, FUSE, 3 AG	352-010
HOLDER, NYLON, for Coil Form 3/16 dia. x 9/16 lg. molded w/o pin	352-016
HOLDER, NYLON, for Coil Form 3/16 dia. x 9/16 lg. molded w/pin	352-017
HOUSING, AIR FILTER SN 101-24602	380-008
HOUSING, AIR FILTER SN 24603-up	380-018
JEWEL, PILOT LIGHT, RED	378-518
KNOB, SMALL RED .694 dia. x 13/32 hi, 3/16 insert hole SN 22060-up	366-032
KNOB, SMALL BLACK .694 dia. x 1/2 hi, 1/4 insert hole	366-033
KNOB, SMALL RED .780 OD x .451 hi, 1/8 hole part way	366-038
KNOB, SMALL RED .780 OD x .451 hi, 3/16 hole part way	366-039
KNOB, LARGE BLACK, 1.375 OD x .650 hi, 1/4 hole thru	366-040
KNOB, LARGE BLACK, 1.375 OD x .650 hi, 17/64 hole thru	366-046
KNOB, LARGE BLACK, 1.625 OD x .655 hi, .250 ID thru	366-058

Mechanical Parts List (continued)

	Tektronix Part Number
KNOB, LARGE BLACK, 1.625 OD x .655 hi, 1/4 hole part way	366-060
LOCKWASHER, STEEL INT #4	210-004
LOCKWASHER, STEEL INT #6	210-006
LOCKWASHER, STEEL EXT #8	210-007
LOCKWASHER, STEEL INT #8	210-008
LOCKWASHER, STEEL INT #10	210-010
LOCKWASHER, STEEL INT 1/4	210-011
LOCKWASHER, STEEL POT INT 3/8 x 1/2	210-012
LOCKWASHER, STEEL INT 3/8 x 11/16	210-013
LOCKWASHER, STEEL #5	210-017
LUG, SOLDER SE4	210-201
LUG, SOLDER SE6 w/2 wire holes	210-202
LUG, SOLDER DE6	210-204
LUG, SOLDER SE8	210-205
LUG, SOLDER SE10, long	210-206
LUG, SOLDER POT Plain 3/8	210-207
LUG, SOLDER 1/4" hole lock round perimeter (.018 thick)	210-223
LUG, SOLDER #10 Non-locking 7/8" long	210-224
LUG, SOLDER SE8, long	210-228
MOTOR, FAN	147-001
MOUNT, FAN MOTOR 7"	426-047
NUT, CAP HEX 8-32 x 5/16	210-402
NUT, HEX 4-40 x 3/16	210-406
NUT, HEX 6-32 x 1/4	210-407
NUT, HEX 8-32 x 5/16	210-409
NUT, HEX 10-32 x 5/16	210-410
NUT, HEX 3/8-32 x 1/2	210-413
NUT, HEX 15/32-32 x 9/16	210-414
NUT, KNURLED, GRATICULE 3/8-24 x 9/16 x 3/16	210-424
NUT, HEX 1/2" x 5/8" lg, 3/8-32 Int. thread (Pot)	210-444
NUT, HEX 10-32 x 3/8 x 1/8 thick	210-445
NUT, HEX 5-40 x 1/4	210-449
NUT, HEX 1/4-28 x 3/8 x 3/32	210-455
NUT, KEPS 6-32 x 5/16	210-457
NUT, KEPS 8-32 x 11/32	210-458

Mechanical Parts List (continued)

	Tektronix Part Number
NUT, HEX 8-32 x 1/2 x 23/64 thick body, 25w res. mtg.	210-462
NUT, POT MINIATURE HEX 1/4-32 x 5/16 dia. x 19/32 lg.	210-471
NUT, SWITCH 15/32-32 x 5/64, 12-sided	210-473
NUT, HEX 6-32 x 5/16 x .194 body, 5-10w res. mtg.	210-478
NUT, HEX 3/8-32 x 1/2 x 11/16	210-494
NUT, 3/8 x 10-32, Cad. Plated	210-501
NUT, 3/8 x 10-32, CRT ROTATOR SN 22060-up	210-502
NUT, 21/32 x 2 1/2 tapped 6-32 both ends, CRT ROTATOR SECURING	210-503
NUT, HEX 10-32 x 3/8 x 1/8	210-564
PANEL, FRONT w/Mod No. slot	333-481
PLATE, ALUM., .125 x 5 1/16 x 6 1/16, Plug-In Housing	386-355
PLATE, BAKELITE 3/32 x 2 3/4 x 5 1/4	386-358
PLATE, BRASS .040 x 2/16 x 1 17/32, Connecting	386-374
PLATE, ALUM., .040 x 4 3/4 x 4 5/8, Air Deflector SN 101-24053	386-496
PLATE, ALUM. .040 x 4 1/4 x 4 15/16, Air Deflector SN 24054-up	386-921
PLATE, ALUM., .063 x 9 1/8 x 6 7/16, Plug-In Housing Side	386-566
PLATE, ALUM., .050 x 20 3/8 x 10 43/64, Cab. Bottom SN 101-24602	386-597
PLATE, ALUM., .050 x 20 3/8 x 10 43/64 Cab. Bottom SN 24603-up	387-061
PLATE, CAB. SIDE, LEFT SN 101-24602	386-736
PLATE, CAB., SIDE LEFT SN 24603-up	387-077
PLATE, SUBPANEL, REAR	386-766
PLATE, REAR OVERLAY SN 101-24602	387-767
PLATE, REAR OVERLAY SN 24603-up	386-078
PLATE, CAB. SIDE w/box SN 101-24602	386-770
PLATE, CAB., SIDE w/box SN 24603-up	387-076
PLATE, ALUM. .080 x 11 5/8 x 11 1/2, Silicon Rect. Mtg.	386-886
PLATE, SUBPANEL, FRONT	386-888
PLATE, TEXTOLITE, 3/32 x 11 5/16 x 12 1/4 Delay Line	386-948
PLATE, TEXTOLITE, 3/32 x 2 1/4 x 8 1/8 Delay Line	386-949
PLATE, TEXTOLITE, 3/32 x 1 1/8 x 2 w/8 eyelets, termination	386-963
PLATE, TEXTOLITE, 3/32 x 1 x 5 1/16, Plate Line	386-964
PLUG, CRT CONTACT, nickel plated	134-031
POST, BINDING, 5-way Stem & Cap Ass'y only fluted cap	129-036
POST, BINDING, BPN13, metal, long	129-051
POST, BINDING, BPN13, metal, short	129-053
RING, SECURING STEEL .335 OD x .145 ID x .025 thick	354-048

Mechanical Parts List (continued)

	Tektronix Part Number
RING, FAN ALUM. $7\frac{3}{8}$ ID w/mtg. ears	354-053
RING, LOCKING SWITCH $2\frac{3}{32}$ OD x $1\frac{5}{32}$ ID	354-055
RING, NYLON MOLDED, ROTATING, 2.215 ID w/handle SN 101-22059	354-066
RING, SECURING 2.4 OD x $2\frac{1}{16}$ ID x $1\frac{3}{16}$ CRT Rotator, SN 22060-up	354-078
RING, NYLON WHITE CLAMPING, $2\frac{3}{32}$ OD x $2\frac{5}{64}$ OD x $\frac{3}{8}$ CRT Rotator, SN 22060-up	354-079
RING, CLAMPING ASS'Y	354-103
ROD, SPACING ALUM. $\frac{1}{4}$ x $3\frac{1}{8}$, tapped 6-32 both ends	384-135
ROD, EXT., STEEL, $\frac{1}{8}$ x $8\frac{7}{16}$	384-162
ROD, EXT., STEEL, $\frac{1}{8}$ x $5\frac{5}{8}$	384-180
ROD, SPACING ALUM. ROUND $\frac{3}{8}$ x 3, tapped 8-32 both ends	384-527
ROD, NYLON, $\frac{5}{16}$ dia. x 1 tapped 6-32 one end w/ #44 hole	385-135
ROD, NYLON, $\frac{5}{16}$ dia. x $1\frac{5}{8}$ tapped 6-32 one end w/ #44 hole	385-138
ROD, ALUM. HEX $\frac{1}{4}$ x $\frac{7}{16}$	385-080
ROD, NYLON, $\frac{5}{16}$ dia. x $2\frac{1}{4}$ tapped 6-32 one end w/2 #44 holes	385-137
ROD, NYLON, $\frac{5}{16}$ OD x $1\frac{9}{16}$ tapped 6-32 both ends	385-090
ROD, NYLON, $\frac{1}{4}$ x $1\frac{1}{4}$ tapped 6-32 one end w/3 #44 holes	385-136
ROD, ALUM., $\frac{1}{4}$ x $3\frac{5}{16}$ tapped 6-32 both ends	385-106
ROD, NYLON, $\frac{5}{16}$ x $1\frac{5}{8}$ tapped 6-32 one end w/3 #50 holes, 1 # $1\frac{1}{16}$	385-129
ROD, ALUM., HEX $\frac{3}{8}$ x $\frac{5}{8}$ tapped 6-32, $\frac{1}{4}$ -28	385-142
SCREW 4-40 x $\frac{3}{16}$ BHS	211-007
SCREW 4-40 x $\frac{1}{4}$ BHS	211-008
SCREW 4-40 x $\frac{5}{16}$ BHS	211-011
SCREW 4-40 x $\frac{3}{8}$ RHS	211-013
SCREW 4-40 x $\frac{5}{8}$ RHS	211-016
SCREW 4-40 x $\frac{1}{4}$ FHS	211-023
SCREW 4-40 x $\frac{3}{8}$ FHS	211-025
SCREW 4-40 x 1 FHS	211-031
SCREW 4-40 x $\frac{5}{16}$ Pan HS w/lockwasher	211-033
SCREW 4-40 x $\frac{1}{2}$ BH Nylon	211-036
SCREW 6-32 x $\frac{3}{16}$ BHS	211-503
SCREW 6-32 x $\frac{1}{4}$ BHS	211-504
SCREW 6-32 x $\frac{5}{16}$ BHS	211-507
SCREW 6-32 x $\frac{3}{8}$ BHS	211-510
SCREW 6-32 x $\frac{1}{2}$ BHS	211-511
SCREW 6-32 x $\frac{1}{2}$ FHS	211-512

Mechanical Parts List (continued)

	Tektronix Part Number
SCREW 6-32 x 7/8 BHS	211-516
SCREW 6-32 x 5/8 FHS 100°	211-522
SCREW 6-32 x 1 1/4 BHS	211-529
SCREW 6-32 x 1 3/4 BHS	211-530
SCREW 6-32 x 5/16 Pan HS w/lockwasher	211-534
SCREW 6-32 x 3/8 Truss HS Phillips	211-537
SCREW 6-32 x 5/16 RHS	211-543
SCREW 6-32 x 1 1/2 RHS Phillips	211-553
SCREW 6-32 x 1 RHS	211-560
SCREW 6-32 x 3/8 Hex Soc FH Cap	211-561
SCREW 6-32 x 1/4 Truss HS Phillips	211-565
SCREW 8-32 x 5/16 BHS	212-004
SCREW 8-32 x 1/2 BHS	212-008
SCREW 8-32 x 3/8 BHS	212-023
SCREW 8-32 x 1 1/4 RHS	212-031
SCREW 8-32 x 1 3/4 Fil HS	212-037
SCREW 8-32 x 3/8 Truss HS Phillips	212-039
SCREW 8-32 x 3/8 FHS 100° Phillips	212-040
SCREW 10-32 x 3 RHS	212-511
SCREW 10-32 x 7/8 RHS	212-548
SCREW, THREAD CUTTING, 4-40 x 3/8 FHS	213-012
SCREW, THREAD CUTTING, 4-40 x 1/4 PHS Phillips	213-035
SCREW, THREAD CUTTING, 6-32 x 3/8 Truss HS Phillips	213-041
SCREW, THREAD CUTTING, 5-32 x 3/16 Pan H Steel Phillips	213-044
SCREW, SELF TAPPING, 4-40 x 5/16 Pan Head Phillips	213-045
SCREW, THREAD FORMING 6-32 x 3/8 THS	213-104
SHIELD, SOCKET, .770 ±.005	337-004
SHIELD, SOCKET, 29/32 ID	337-005
SHIELD, TUBE, 7/8 ID w/spring 1 3/8 hi.	337-006
SHIELD, TUBE, 1 1/32 ID w/spring 1 5/16 hi.	337-008
SHIELD, TUBE, 1 1/32 ID w/spring 2 13/32 hi.	337-009
SHIELD, PLUG-IN HOUSING TOP, ALUM. 5 5/16 x 8 3/4 x 2 1/8	337-066
SHIELD, CRT	337-088
SHIELD, ALUM., 7 7/8 x 6 13/32, Plug-In Housing	337-091
SHIELD, ALUM., 6 3/4 x 3 3/8 x 1 1/2, F & I	337-148
SHIELD, 5" GRATICULE LIGHT	337-187
SHIELD, ALUM., 1 5/8 x 1 7/8 x 1 1/8	337-279
SHIELD, 500A SERIES HV	337-287

Mechanical Parts List (continued)

	Tektronix Part Number
SHIELD, RECT. PLEXI 5 x 2 $\frac{1}{2}$ x $\frac{1}{16}$	337-288
SHIELD, ALUM., 2 x 4 $\frac{3}{8}$, SWEEP AMP	337-289
SHIELD, ALUM., 1 $\frac{3}{4}$ x 1 $\frac{5}{16}$, UPPER CAL	337-290
SHIELD, ALUM., 2 $\frac{1}{2}$ x 2 $\frac{3}{8}$ x 1 $\frac{1}{16}$, LOWER CAL	337-291
SHOCKMOUNT, RUBBER, 275-1 Hollow $\frac{1}{2}$ " dia. x $\frac{5}{8}$ hi.	348-008
SOCKET, GRATICULE LAMP	136-001
SOCKET, STM7G	136-008
SOCKET, STM8, Ground	136-011
SOCKET, STM9G	136-015
SOCKET, STM14 1 $\frac{1}{8}$ " thick, Mica, 14-Pin	136-019
SOCKET, STM9S	136-022
SOCKET, LIGHT JEWEL	136-025
SOCKET, TIP JACK, BLACK NYLON $\frac{1}{2}$ " OD threaded $\frac{3}{8}$ -32 x $\frac{1}{2}$	136-037
SOCKET, 7-pin Tube, BAKE, GND. LUGS w/1 $\frac{1}{8}$ " dia. mtg. holes	136-044
SPACER, $\frac{5}{32}$ nylon, molded .156-.250 dia. x .063 for ceramic strip	361-007
SPACER, $\frac{3}{8}$ nylon, molded .156-.250 dia. x .313 for ceramic strip	361-009
STOP, ALUM. HEX, $\frac{1}{4}$ x $\frac{3}{4}$ threaded 6-32 one end, Delay Sweep Chassis	105-014
STRAP, MOUNTING 535 HV Transf. Alum. .025 x $\frac{5}{16}$ x 4 $\frac{1}{4}$	346-001
STRIP, FELT $\frac{1}{8}$ x 1 x 5 $\frac{3}{4}$ Grey	124-068
STRIP, CERAMIC $\frac{3}{4}$ x 2 notches, clip mounted	124-086
STRIP, CERAMIC $\frac{3}{4}$ x 4 notches, clip mounted	124-088
STRIP, CERAMIC $\frac{3}{4}$ x 7 notches, clip mounted	124-089
STRIP, CERAMIC $\frac{3}{4}$ x 9 notches, clip mounted	124-090
STRIP, CERAMIC $\frac{3}{4}$ x 11 notches, clip mounted	124-091
STRIP, CERAMIC 1 notch, clip mounted	124-100
STUD, STEEL, 10-32 x 2 $\frac{7}{16}$, 2 under shoulder	355-044
STUD, STEEL, $\frac{3}{16}$ x 3 $\frac{1}{4}$ x 10-32, thread 2 $\frac{1}{4}$ down, CRT Rotator	355-049
TAG, VOLTAGE RATING 117V-105-125 VOLTS, 50-60 cycle	334-649
TUBE, SPACER ALUM., .180 ID x $\frac{1}{4}$ OD x $\frac{5}{8}$ lg.	166-037
TUBE, SPACER ALUM., .180 ID x $\frac{1}{4}$ OD x $\frac{3}{4}$ lg.	166-038
TUBE, SPACING ALUM., .180 ID x $\frac{1}{4}$ OD x 1 $\frac{23}{32}$ tapped 6-32	166-099
TUBE, FORM COIL ZYTEL, .242 ID x $\frac{5}{16}$ OD x $\frac{1}{8}$ th. Retaining	166-103
TUBE, SPACING ALUM., .245 ID x $\frac{3}{8}$ OD x 2 $\frac{19}{32}$ lg.	166-105
TUBE, SPACING ALUM., .180 ID x $\frac{1}{4}$ OD x $\frac{7}{32}$, 1 end counter sunk	166-107
TUBE, SPACER ALUM., .065 ID x $\frac{3}{8}$ OD x 1 $\frac{3}{16}$	166-143
WASHER, STEEL, 6L x $\frac{3}{8}$ x .032	210-803

Mechanical Parts List (continued)

	Tektronix Part Number
WASHER, STEEL, 8S x $\frac{3}{8}$ x .032	210-804
WASHER, STEEL, 10S x $\frac{7}{16}$ x .036	210-805
WASHER, BRASS, CENTERING RES. 25 W	210-809
WASHER, FIBER, #6 Shouldered	210-811
WASHER, FIBER, #10	210-812
WASHER, RUBBER, WAN 13-20	210-816
WASHER, ALUM., RECTIFIER $\frac{1}{4}$ ID x $\frac{1}{2}$ OD x .046	210-821
WASHER, STEEL, .390 ID x $\frac{9}{16}$ OD x .020	210-840
WASHER, STEEL, .119 ID x $\frac{3}{8}$ OD x .025 thick, flat (#41)	210-851
WASHER, RUBBER, $\frac{1}{2}$ ID x $1\frac{1}{16}$ OD x $\frac{3}{64}$, for fuse holder	210-873
WASHER, CENTERING $\frac{3}{8}$ OD x $\frac{1}{8}$ " thick	210-886
WASHER, STEEL, flat .470 ID x $2\frac{1}{32}$ OD x .030 thick	210-902
WASHER, WAVY, .007 Phos. Bronze .492 OD x .320 ID x .035	210-914

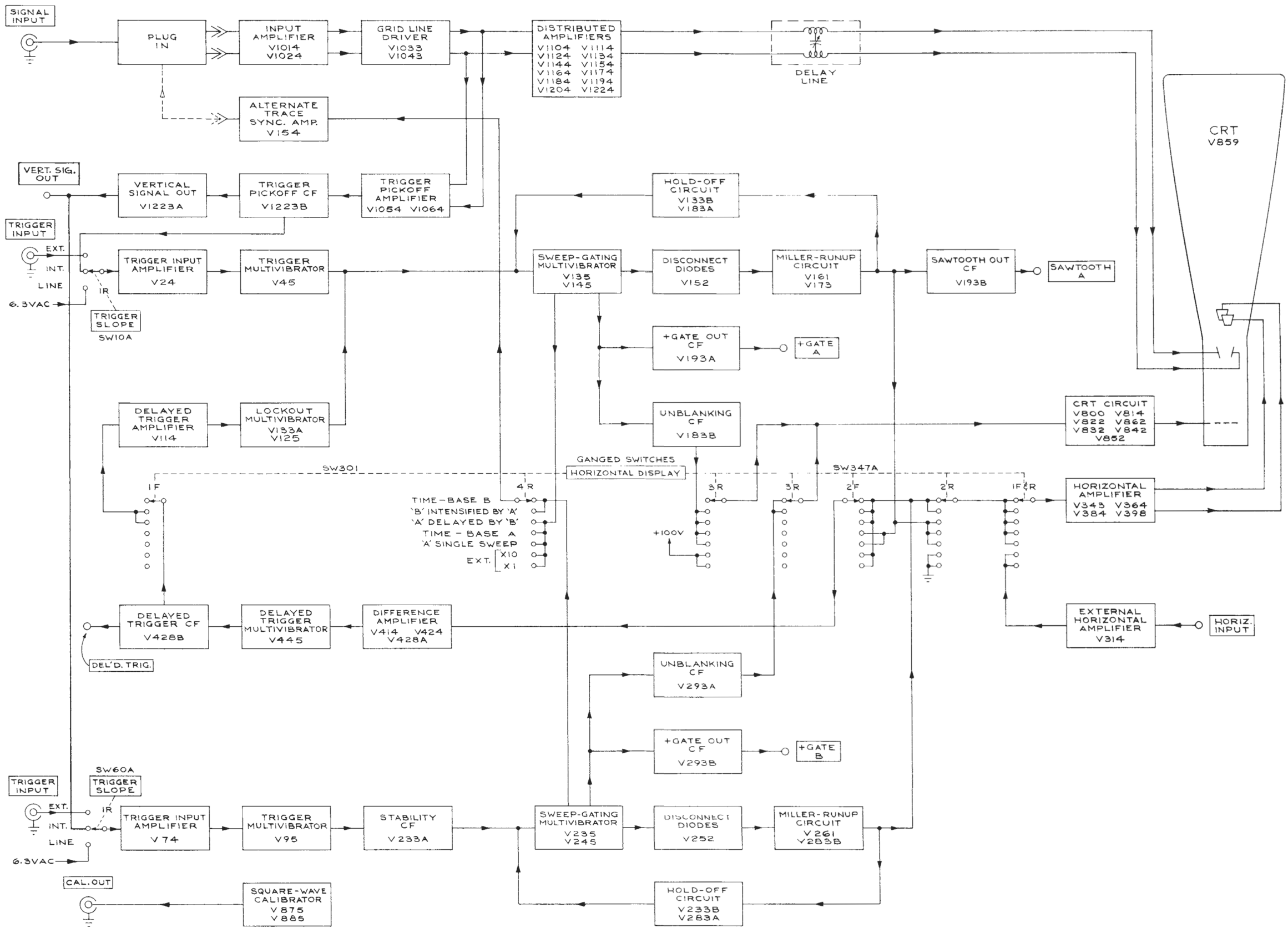

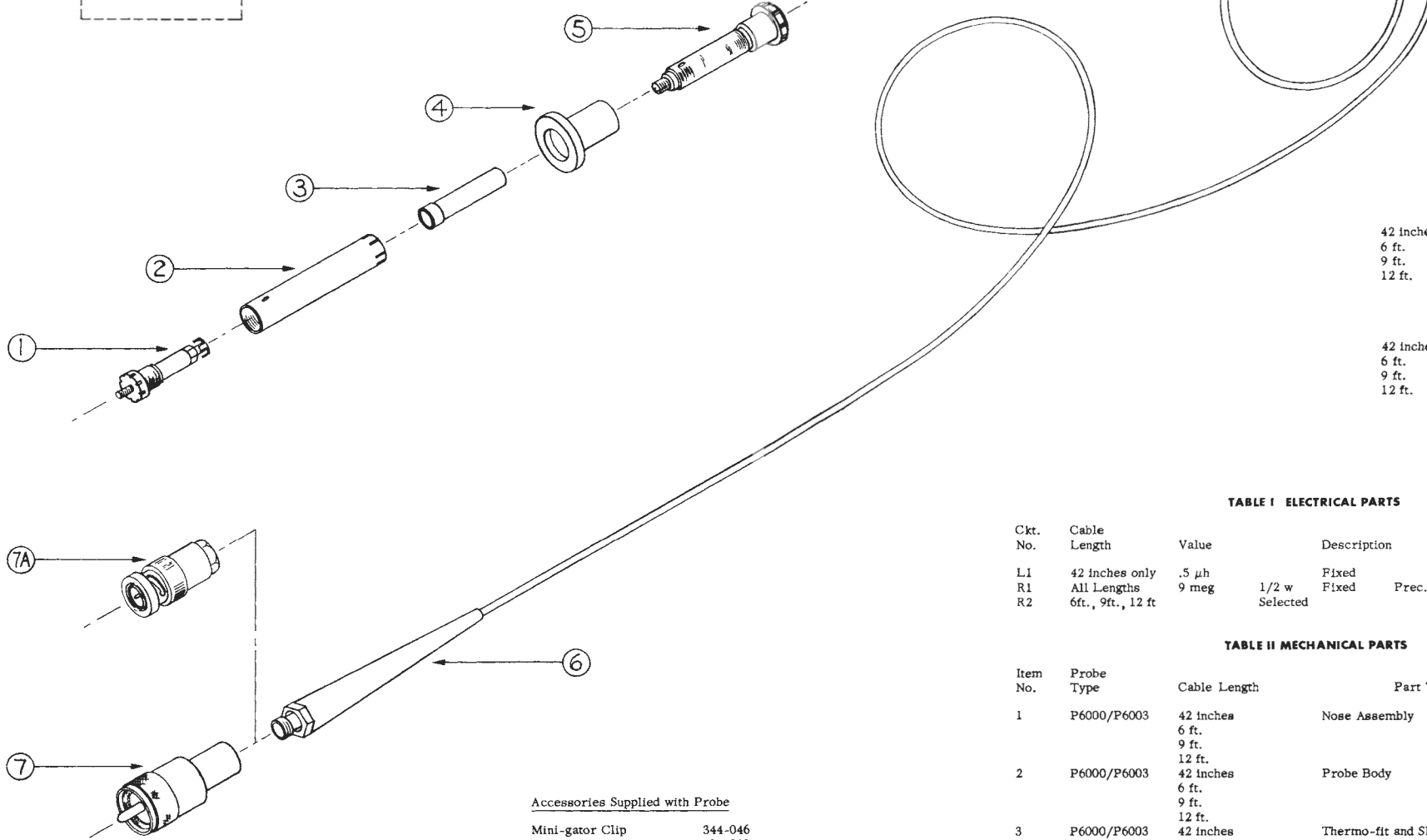
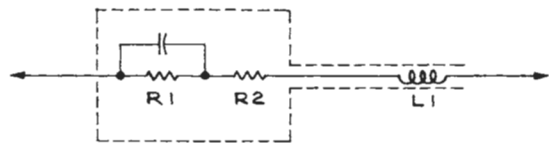

PROBES THIS SHEET COVERS

P6000

42 inches	Tektronix Part No.	010-020
6 ft.		010-030
9 ft.		010-035
12 ft.		010-041

P6003

42 inches	Tektronix Part No.	010-027
6 ft.		010-031
9 ft.		010-045
12 ft.		010-046

TABLE I ELECTRICAL PARTS

Ckt. No.	Cable Length	Value	Description	Tektronix Part No.
L1	42 inches only	.5 μ h	Fixed	108-211
R1	All Lengths	9 meg	1/2 w Fixed Prec. 2%	309-232
R2	6ft., 9ft., 12 ft		Selected	

TABLE II MECHANICAL PARTS

Item No.	Probe Type	Cable Length	Part Title	Tektronix Part No.
1	P6000/P6003	42 inches	Nose Assembly	206-014
		6 ft.		206-014
		9 ft.		206-068
		12 ft.		206-056
2	P6000/P6003	42 inches	Probe Body	204-021
		6 ft.		204-021
		9 ft.		204-021
		12 ft.		204-057
3	P6000/P6003	42 inches	Thermo-fit and Sleeve Assembly	166-212
		6 ft.		166-214
		9 ft.		166-219
		12 ft.		166-216
4	P6000	42 inches	Locking Ring	105-022
		P6003		105-028
		P6000		105-024
		P6003		105-025
		P6000		105-029
		P6003		105-033
		P6000		105-030
5	P6000/P6003	All Lengths	Assembly Base Bushing	358-121
		P6000		175-159
		P6003		175-162
		P6000		175-165
6	P6000	42 inches	Cable Assembly	175-168
		P6000		175-165
		P6003		175-171
		P6000		175-171
		P6003		175-174
		P6000		175-177
		P6003		175-180
7	P6000	All Lengths	Connector, UHF	131-058
7A	P6003	All Lengths	Connector, BNC	131-185

Accessories Supplied with Probe

Mini-gator Clip	344-046
Banana Plug	134-013
Probe Holder	352-024
Hook Tip	206-105
BNC Tip	206-015
Spring Tip	206-060
Pincer Tip	013-027
5 inch Ground Strap	175-124
12 inch Ground Strap	175-125

Accessories That May be Purchased

BNC to Probe Adaptor	013-020
Spring Tip without Shank	206-061
Pinjack Tip, Insulated	206-054
Insert Tip	206-052
Pinjack Tip	206-045
Straight Tip	206-104
18 inch Ground Strap	175-184

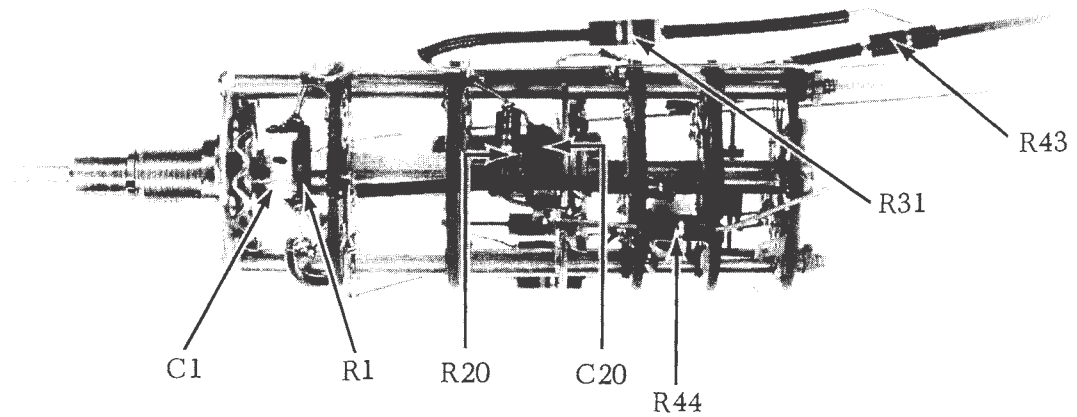

TIME BASE A TRIGGER SLOPE
TRIGGERING MODE SWITCH

Top View

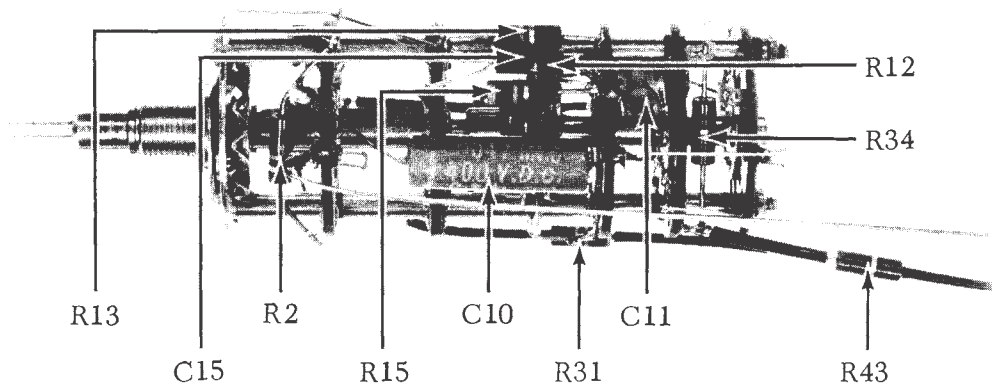

TIME BASE A TRIGGER SLOPE
TRIGGERING MODE SWITCH

Bottom View

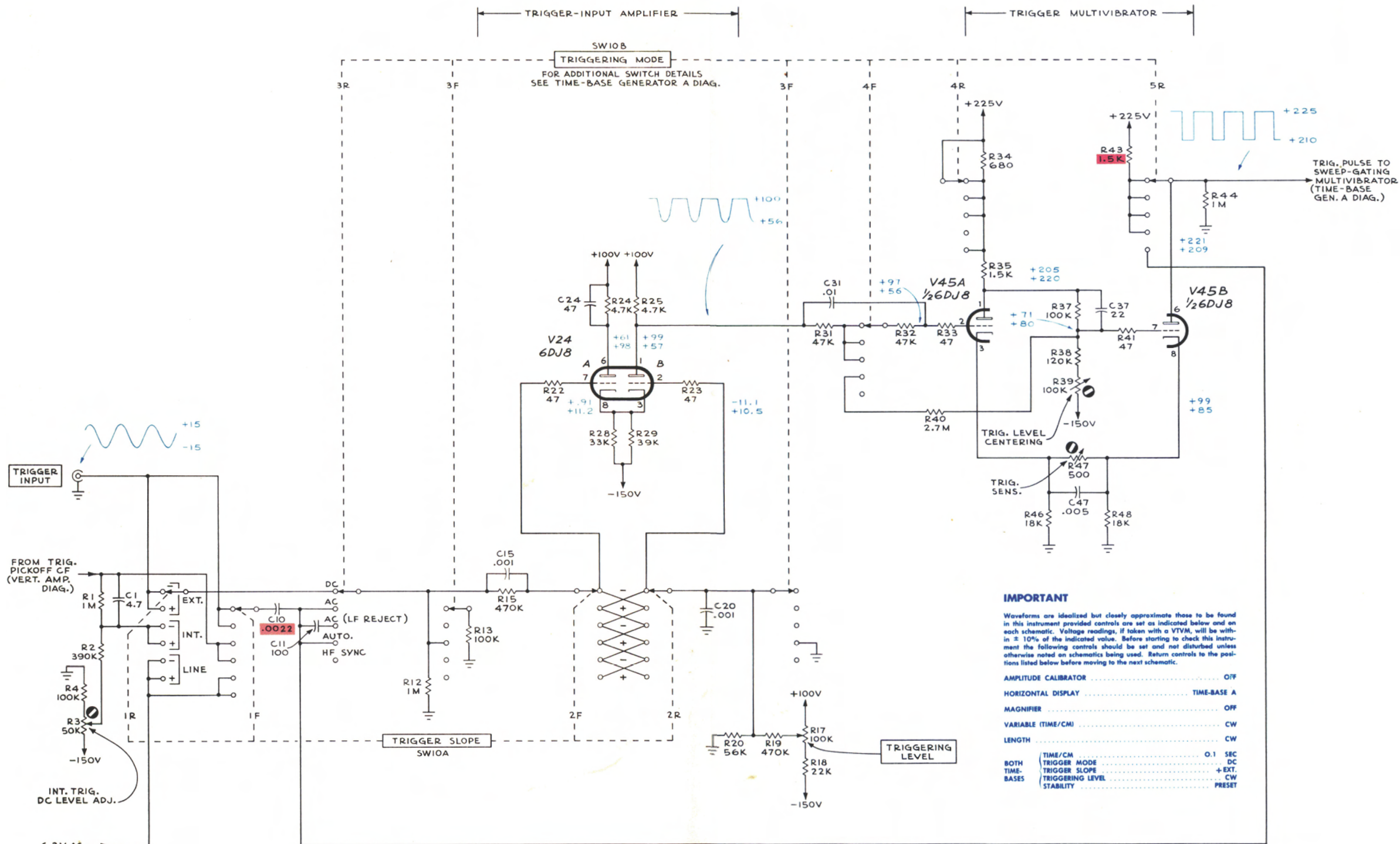

IMPORTANT

Waveforms are idealized but closely approximate those to be found in this instrument provided controls are set as indicated below and on each schematic. Voltage readings, if taken with a VTVM, will be within $\pm 10\%$ of the indicated values. Before starting to check this instrument the following controls should be set and not disturbed unless otherwise noted on schematics being used. Return controls to the positions listed below before moving to the next schematic.

- AMPLITUDE CALIBRATOR OFF
- HORIZONTAL DISPLAY TIME-BASE A
- MAGNIFIER OFF
- VARIABLE (TIME/CM) CW
- LENGTH CW
- BOTH TIME-BASES
 - TRIGGER MODE DC
 - TRIGGER SLOPE +EXT.
 - TRIGGERING LEVEL CW
 - STABILITY PRESET

SEE PARTS LIST FOR EARLIER VALUES & S/N CHANGES OF PARTS MARKED

WAVEFORMS AND VOLTAGE READINGS
WERE OBTAINED WITH CONTROLS SET AS FOLLOWS:

EXTERNAL TRIGGER SIGNAL
FOR WAVEFORMS 2KC
FOR VOLTAGES NONE

TRIGGERING LEVEL
FOR WAVEFORMS CW
FOR UPPER VOLTAGE READINGS CCW
FOR LOWER VOLTAGE READINGS CW

SEE ALSO IMPORTANT NOTE ON THIS DIAGRAM

GAB
11-9-61

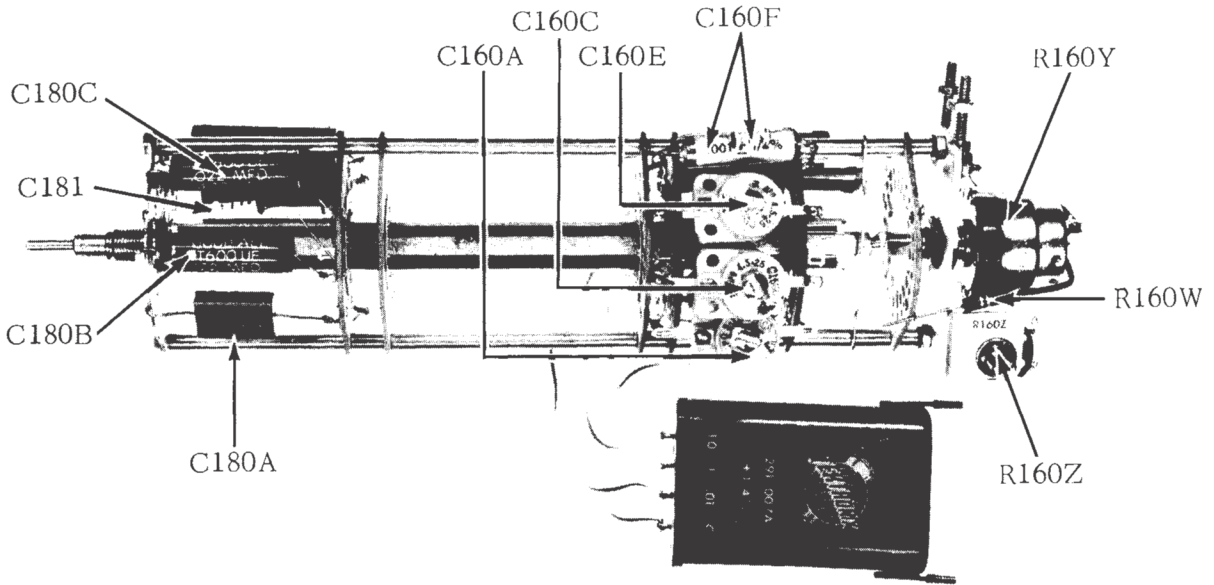

TIME BASE A TIME/CM SWITCH

Right Side View

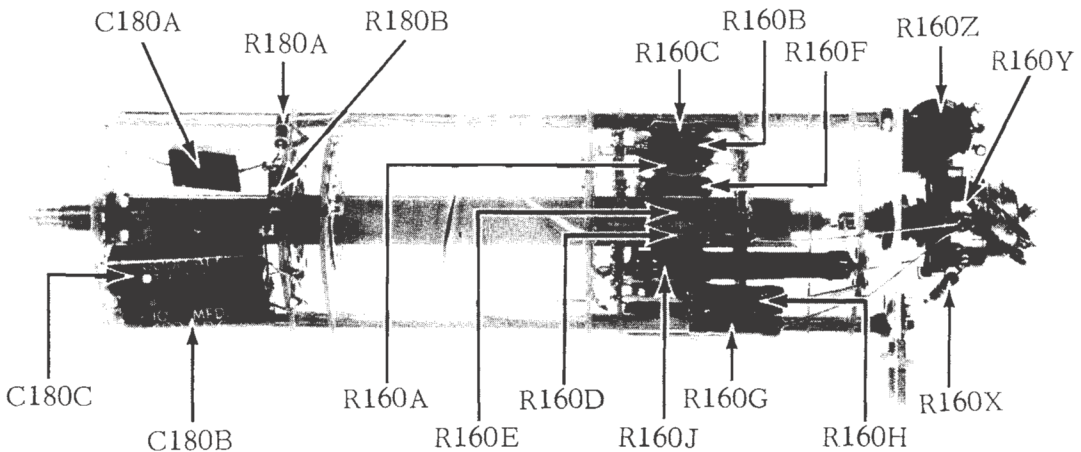

TIME BASE A TIME/CM SWITCH

Left Side View

TO CATH., PIN 8, V183A
HOLD-OFF CF
(TIME-BASE GEN. A DIAG.)

TO GRID, PIN 9, V161
MILLER RUNUP TUBE
(TIME-BASE GEN. DIAG.)

TO CATH., PINS 3 & 8, V173
RUNUP CF
(TIME-BASE GEN. A DIAG.)

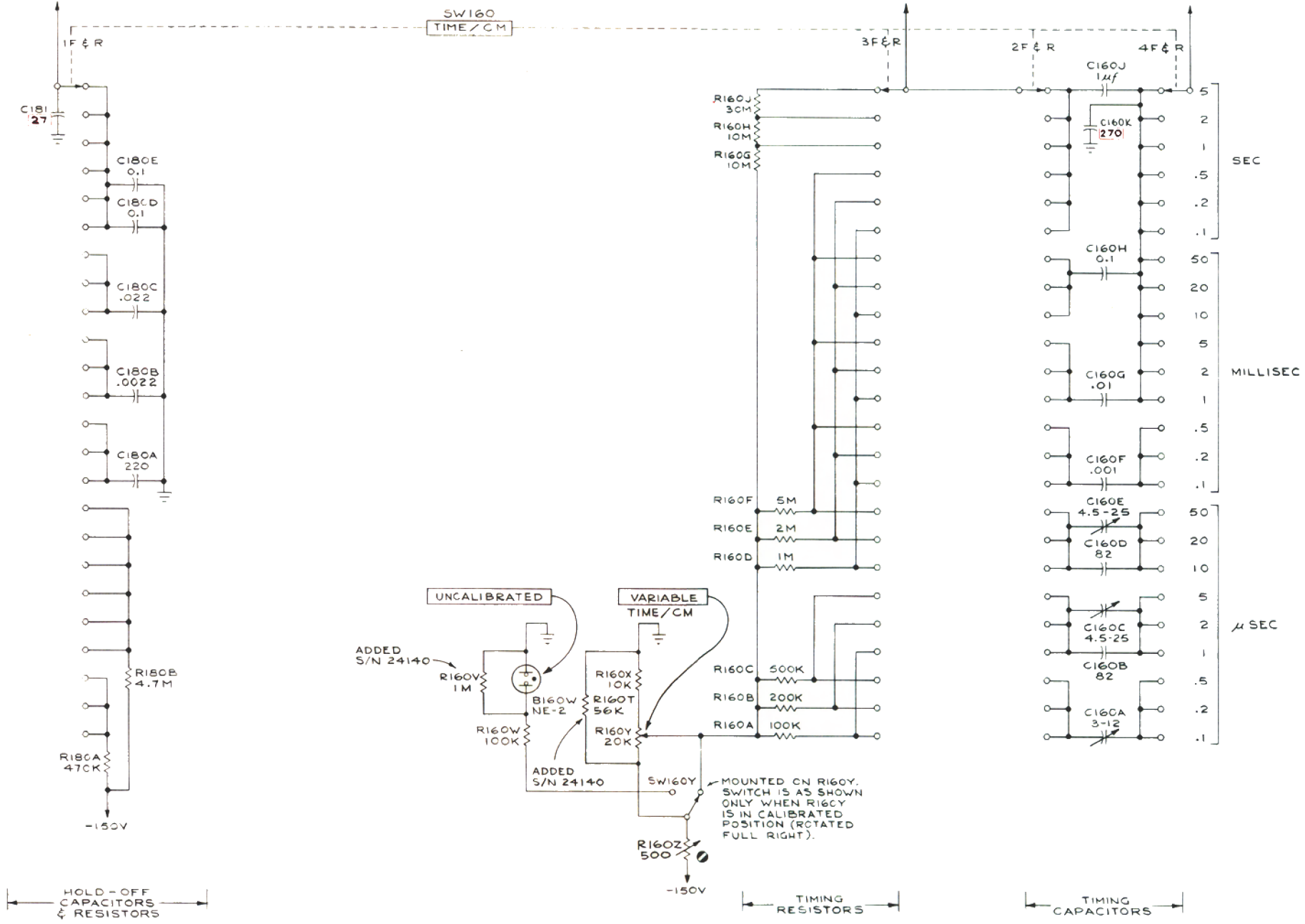

SEE PARTS LIST FOR EARLIER
VALUES AND S/N CHANGES OF
PARTS MARKED WITH RED
TINT BLOCKS

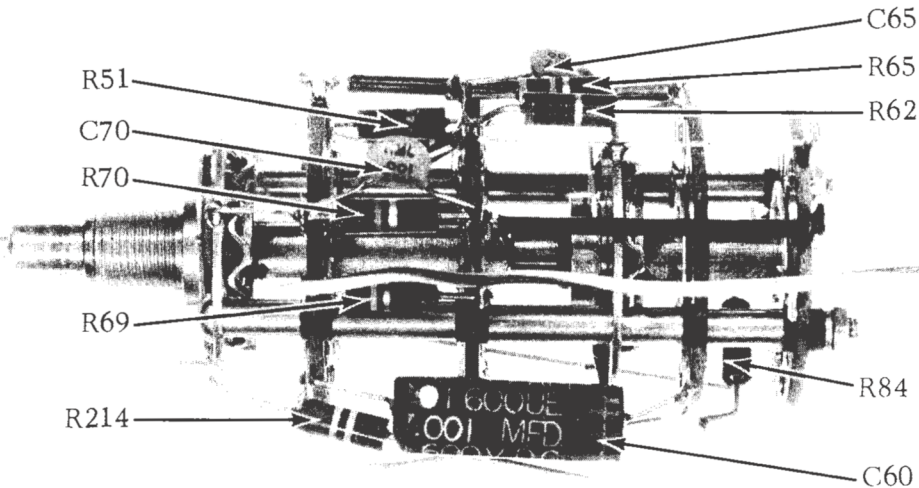

TIME BASE B TRIGGER SLOPE TRIGGERING MODE SWITCH

Top View

545A

A

TRIGGER INPUT AMPLIFIER

TRIGGER MULTIVIBRATOR

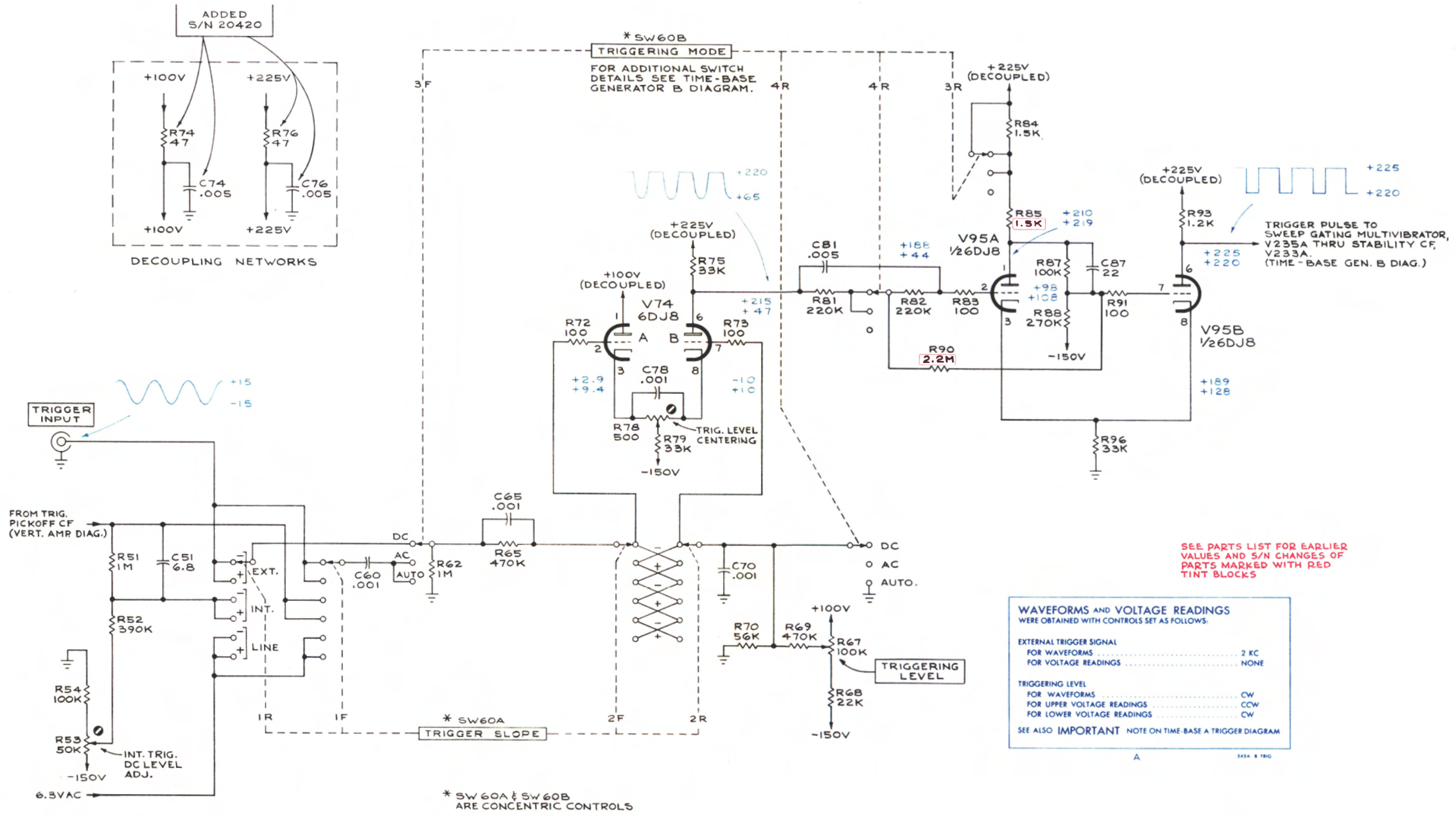

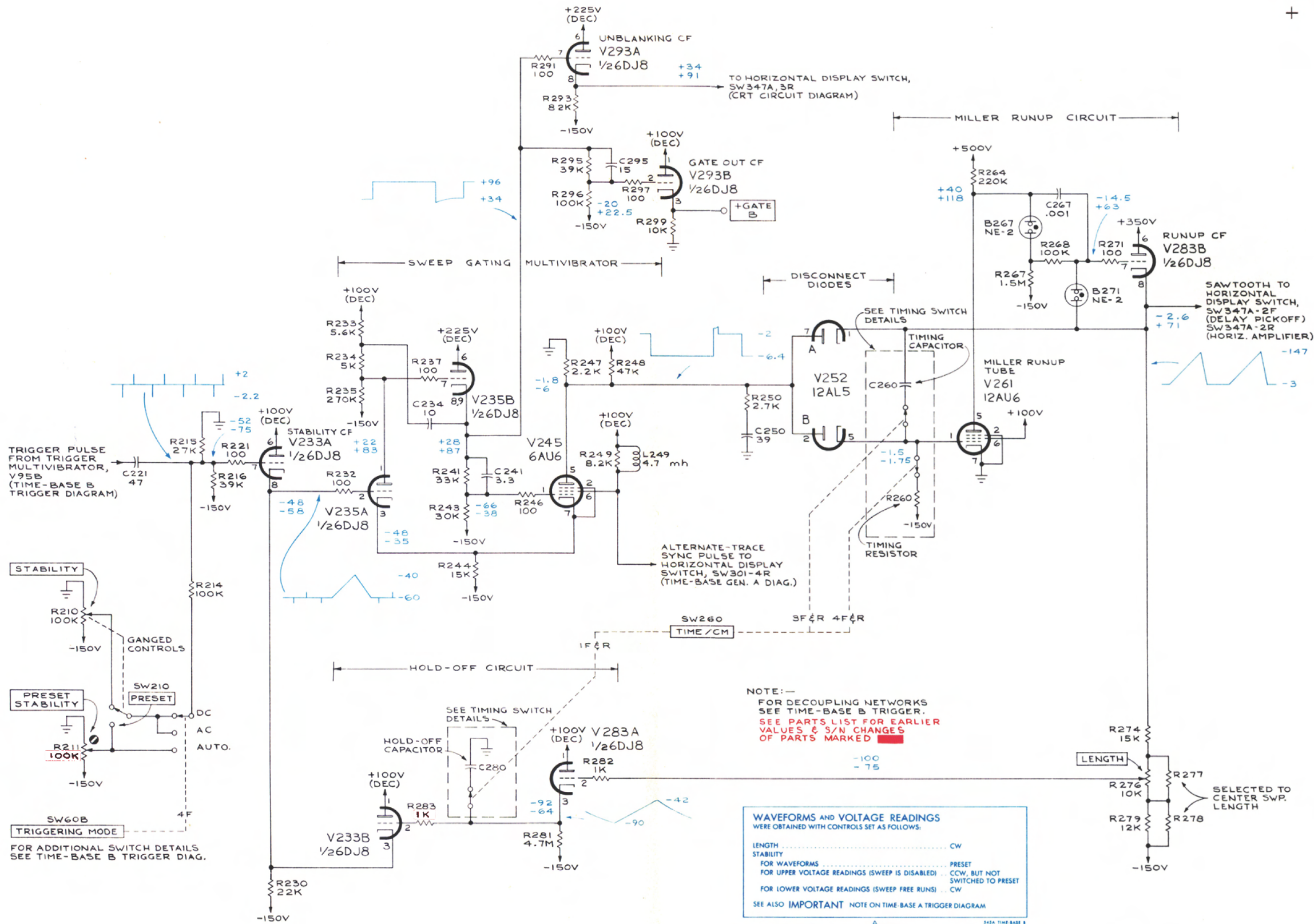

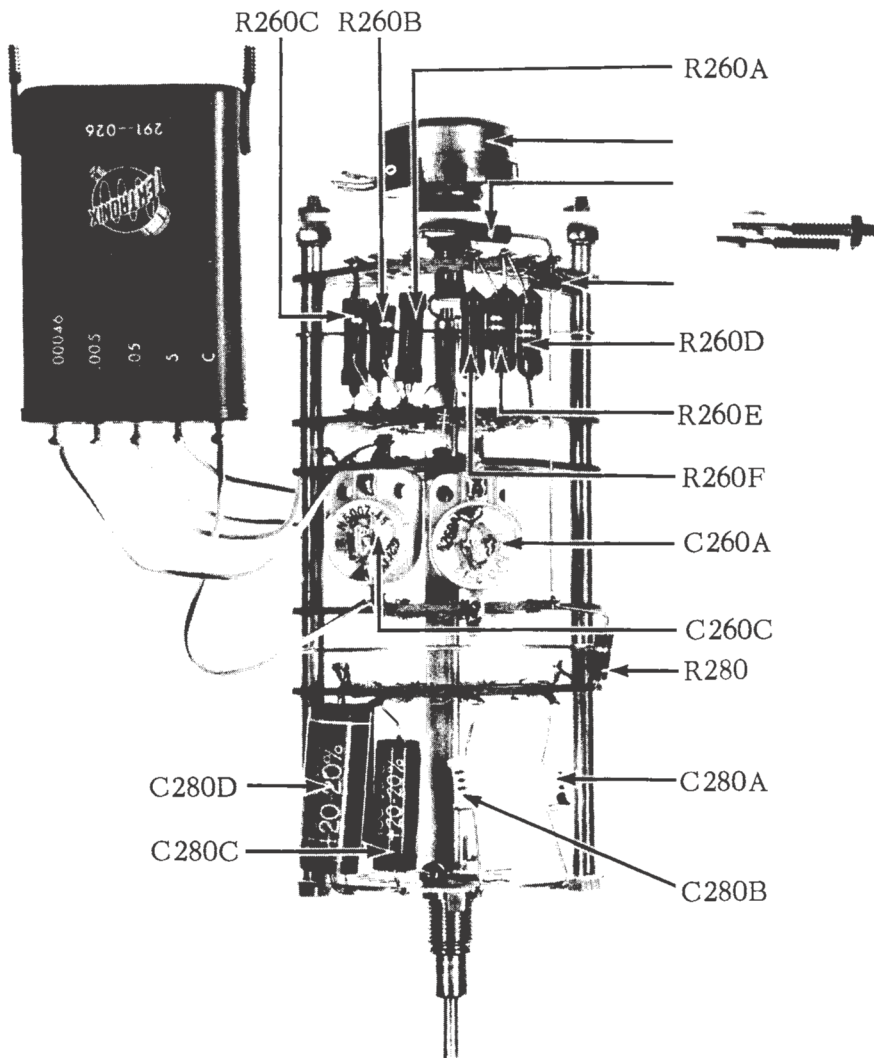

TIME BASE B TIME/CM SWITCH

Right Side View

TO CATH., PIN 3, V283A
HOLD-OFF CF
(TIME-BASE GEN. B DIAG.)

TO CATH., PIN 8, V283B
RUNUP CF
(TIME-BASE GEN. B DIAG.)

TO GRID, PIN 1, V261
MILLER RUNUP TUBE
(TIME-BASE GEN. B DIAG.)

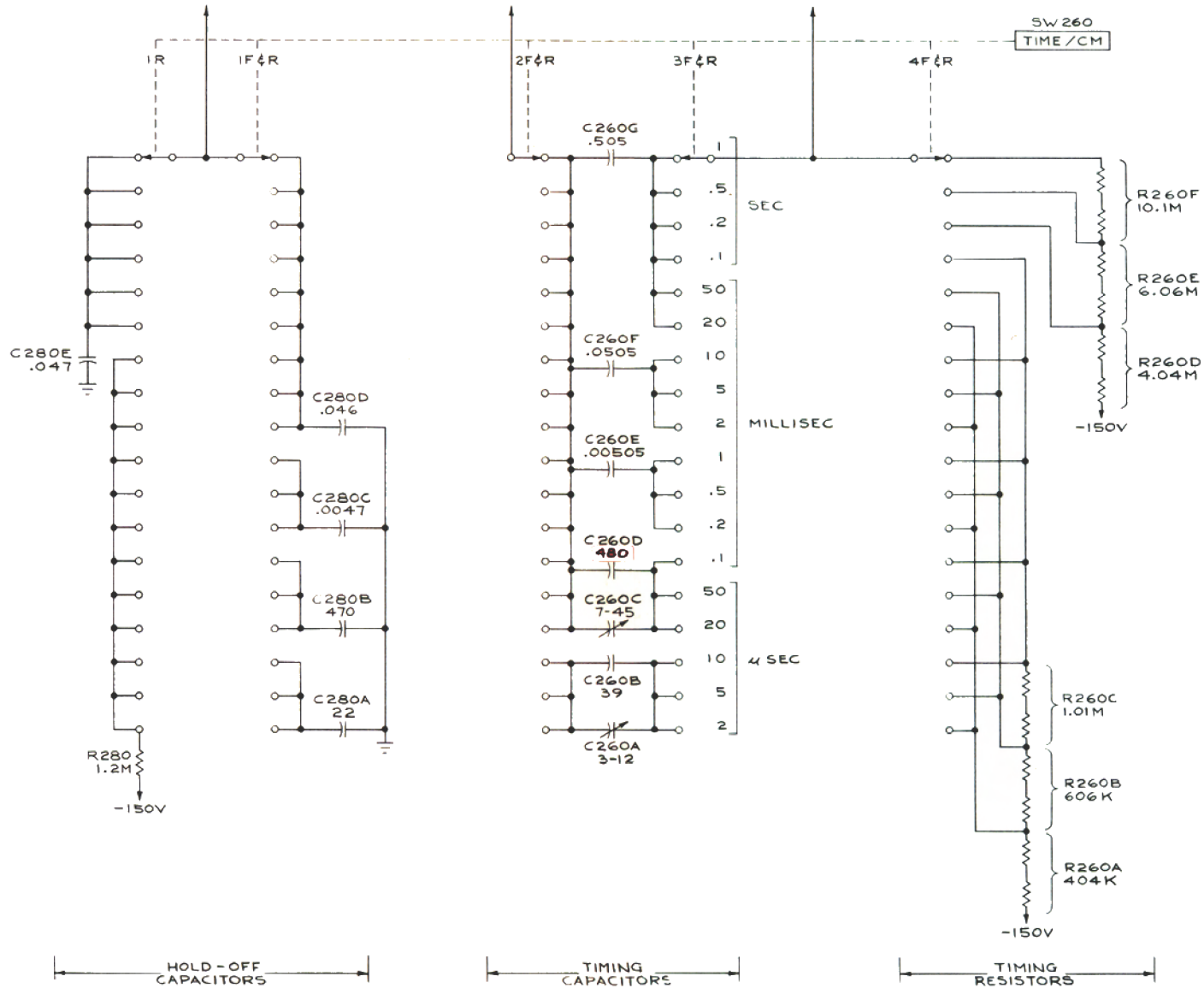

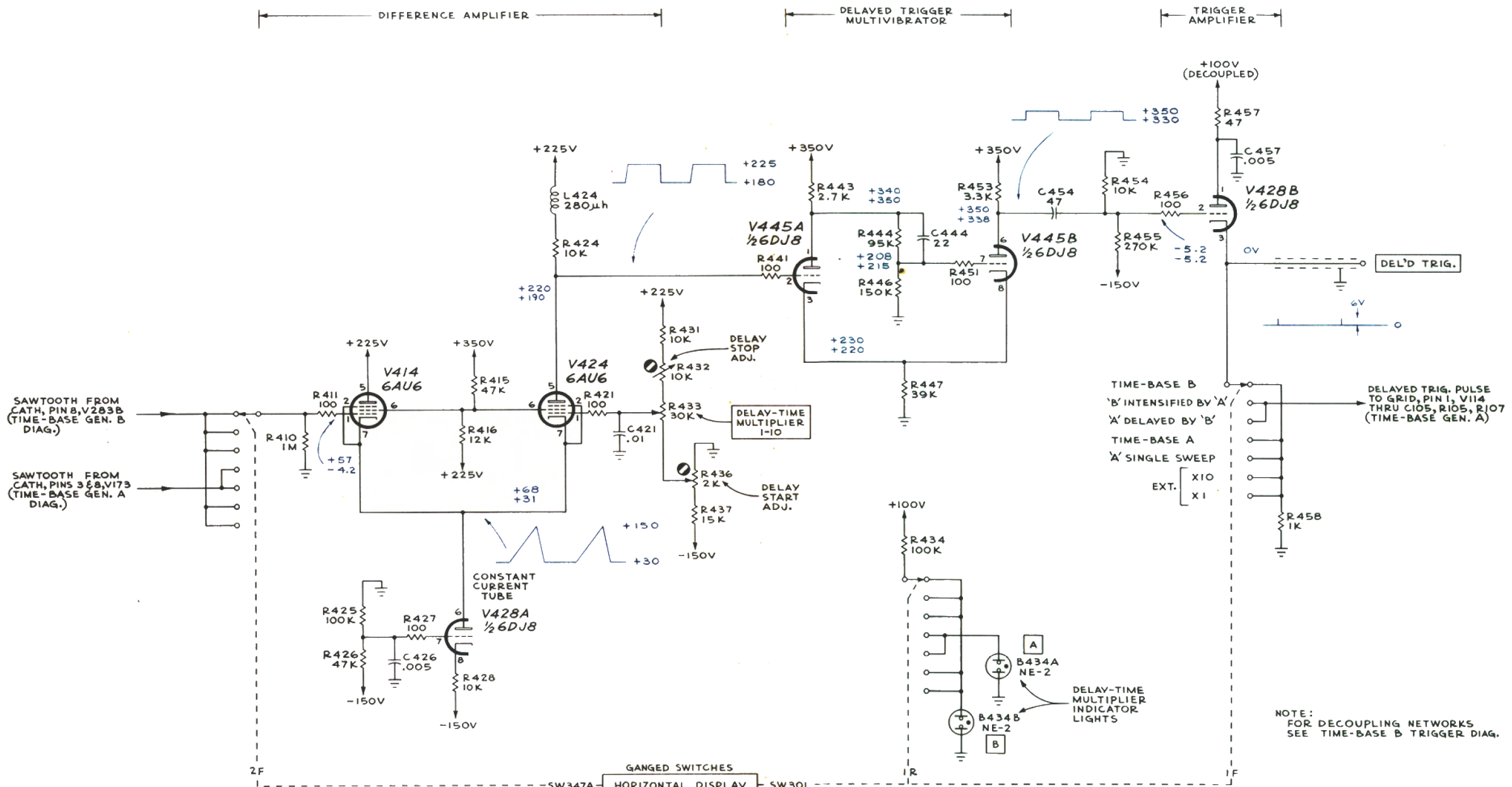

SAWTOOTH FROM CATH. PIN 8, V283B (TIME-BASE GEN. B DIAG.)

SAWTOOTH FROM CATH. PINS 3 & 8, V173 (TIME-BASE GEN. A DIAG.)

CONSTANT CURRENT TUBE
V428A
½ 6DJ8

GANGED SWITCHES

SW347A HORIZONTAL DISPLAY SW301

FOR ADDITIONAL SWITCH DETAILS SEE:
C.R.T. DIAG.
HORIZ. AMP. DIAG.
BLOCK DIAG.
EXT. HORIZ. AMP. DIAG.
TIME-BASE GEN. A DIAG.

WAVEFORMS AND VOLTAGE READINGS

WERE OBTAINED WITH CONTROLS SET AS FOLLOWS:

EXT. TRIGGER INPUT SIGNAL (TIME-BASE-A) 2 KC
HORIZONTAL DISPLAY TIME-BASE A
DELAY-TIME MULTIPLIER 2.0
STABILITY (TIME-BASE A) PRESET
FOR WAVEFORMS PRESET
FOR UPPER VOLTAGE READINGS CW
FOR LOWER VOLTAGE READINGS CW, BUT NOT SWITCHED TO PRESET

SEE ALSO IMPORTANT NOTE ON TIME-BASE A TRIGGER DIAGRAM

NOTE:
FOR DECOUPLING NETWORKS
SEE TIME-BASE B TRIGGER DIAG.

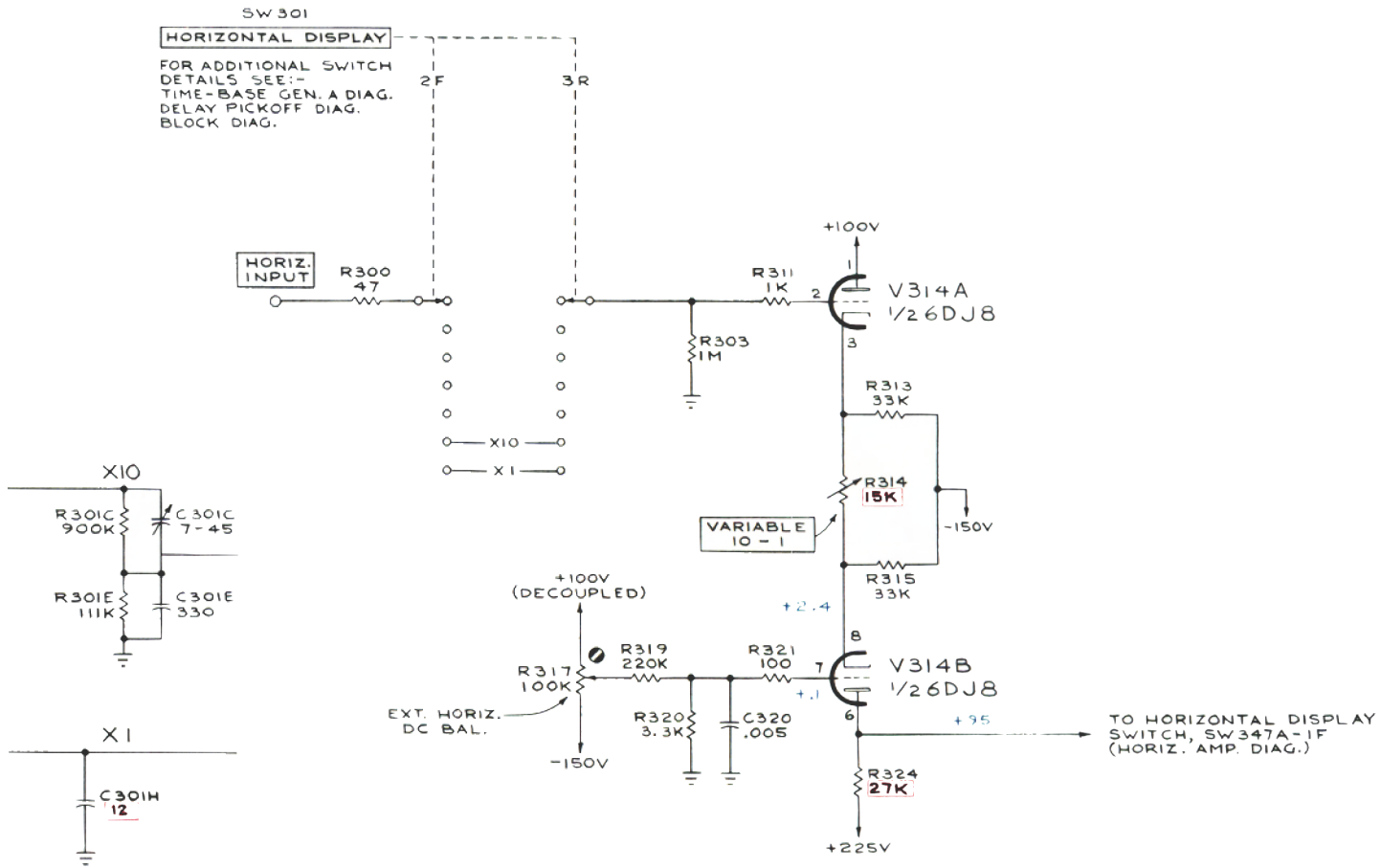

NOTE:-

FOR DECOUPLING NETWORKS
SEE TIME-BASE B TRIGGER.

SEE PARTS LIST FOR EARLIER
VALUES AND S/N CHANGES
OF PARTS MARKED

VOLTAGE READINGS WERE OBTAINED
WITH CONTROLS SET AS FOLLOWS:

EXTERNAL HORIZONTAL INPUT SIGNAL	NONE
HORIZONTAL DISPLAY	EXT X10
VARIABLE 10-1	CW

SEE ALSO IMPORTANT NOTE ON TIME-BASE A TRIGGER DIAGRAM

A

TYPE 545A HORIZ. AMP.

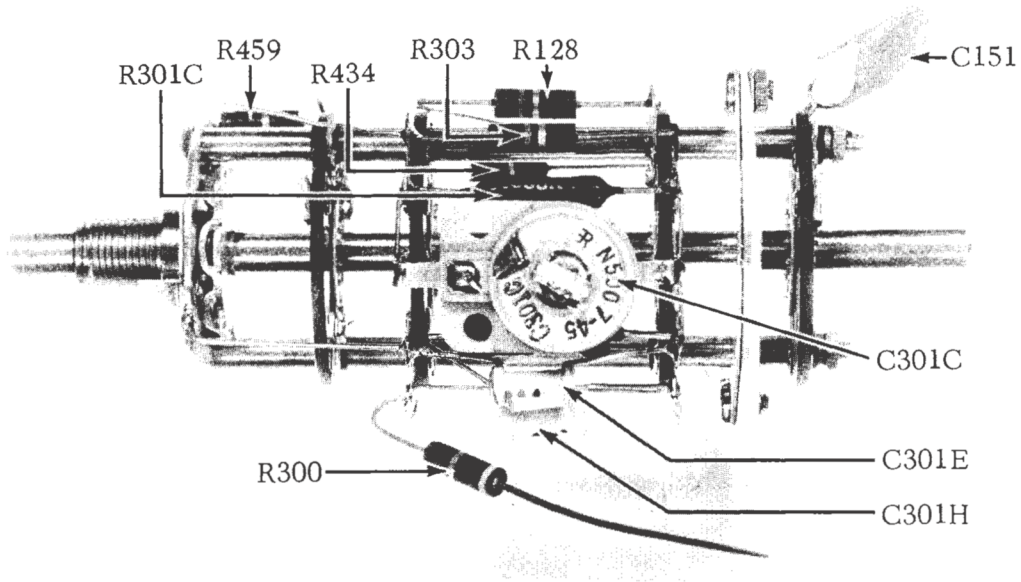

HORIZONTAL DISPLAY SWITCH

Right Side View

545A

A

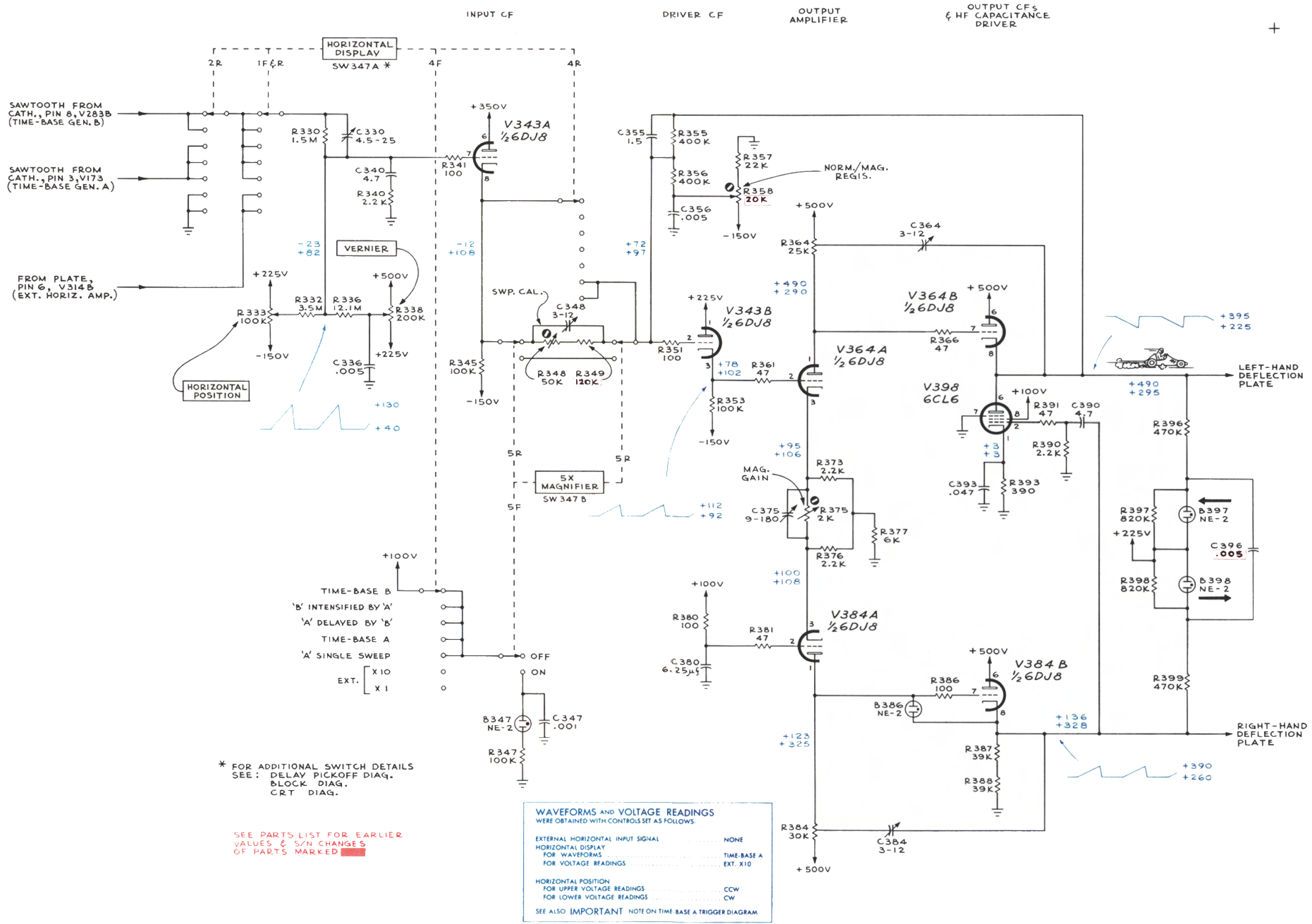

TYPE 545A OSCILLOSCOPE

HORIZONTAL AMPLIFIER

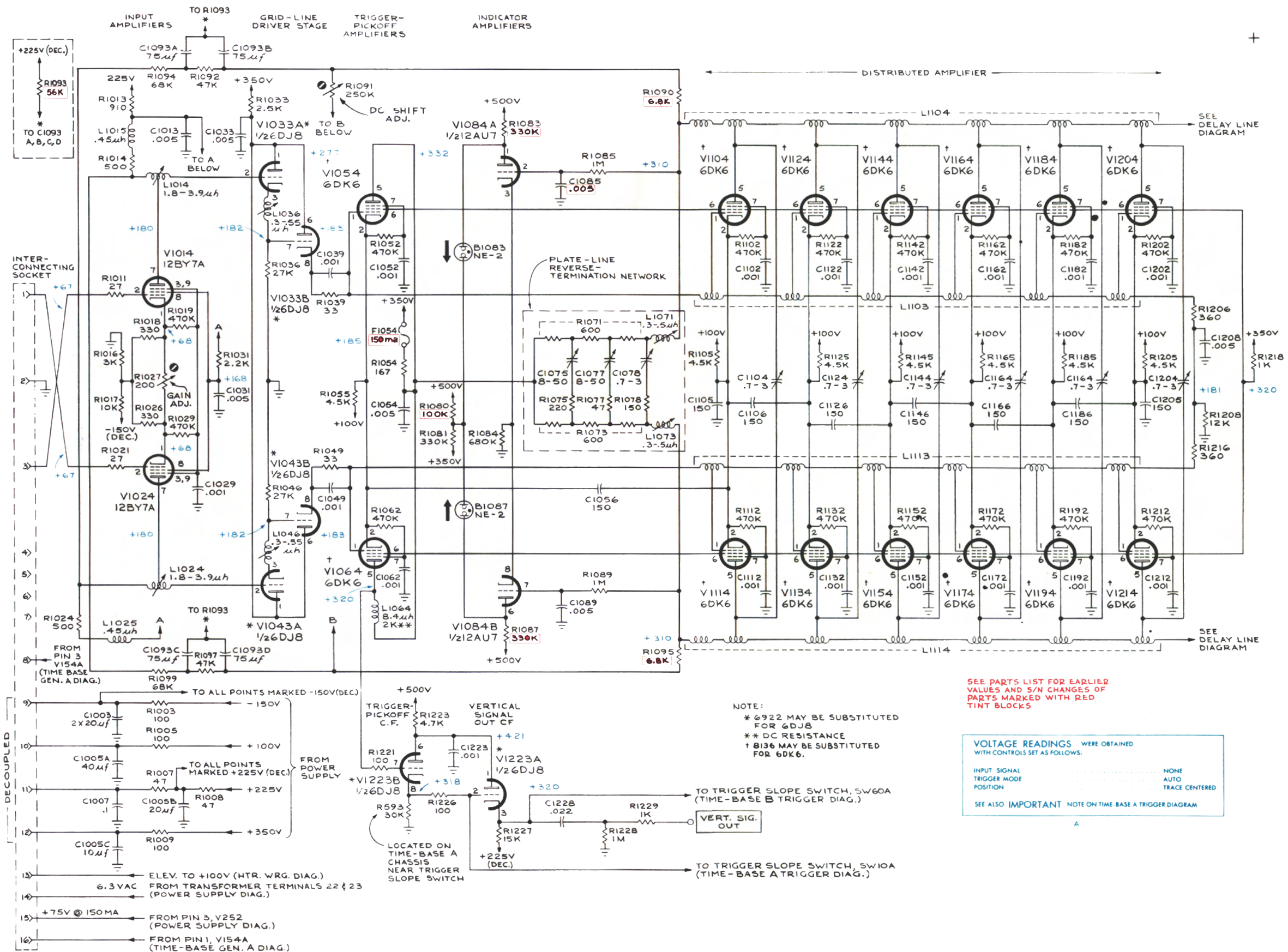

SEE PARTS LIST FOR EARLIER VALUES AND S/N CHANGES OF PARTS MARKED WITH RED TINT BLOCKS

NOTE:
 * 6922 MAY BE SUBSTITUTED FOR 6DJ8
 ** DC RESISTANCE
 † 8136 MAY BE SUBSTITUTED FOR 6DK6.

VOLTAGE READINGS WERE OBTAINED WITH CONTROLS SET AS FOLLOWS:
 INPUT SIGNAL NONE
 TRIGGER MODE AUTO
 POSITION TRACE CENTERED
 SEE ALSO IMPORTANT NOTE ON TIME-BASE A TRIGGER DIAGRAM

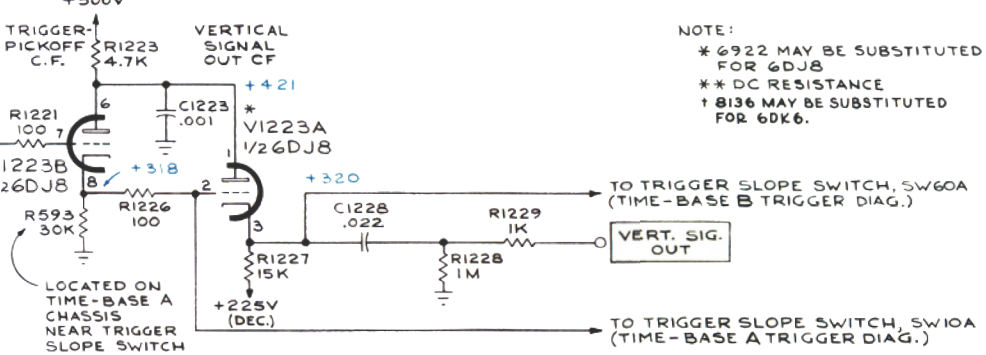
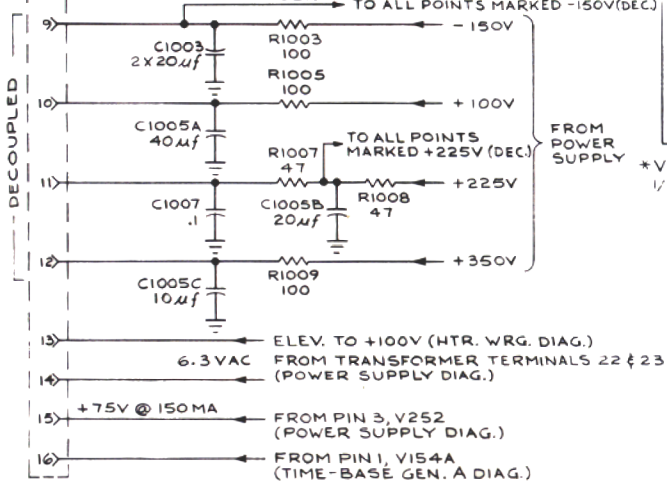

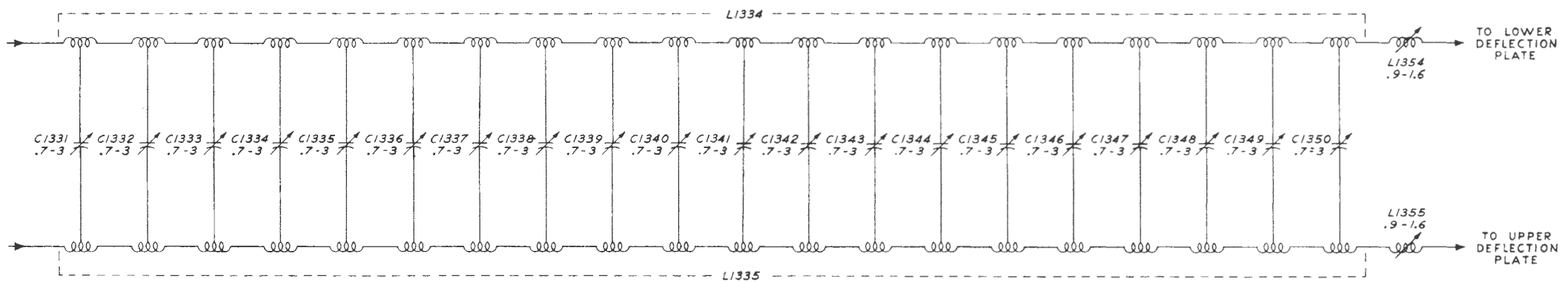
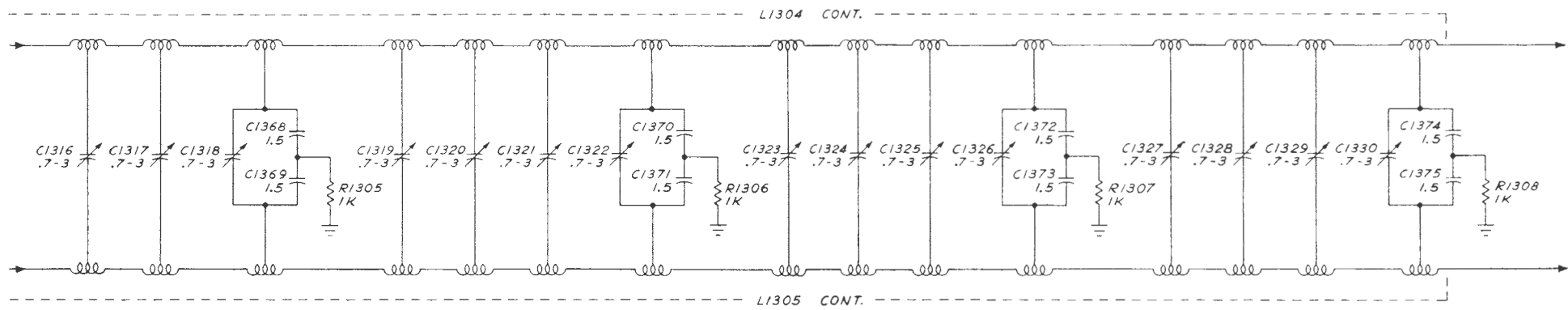
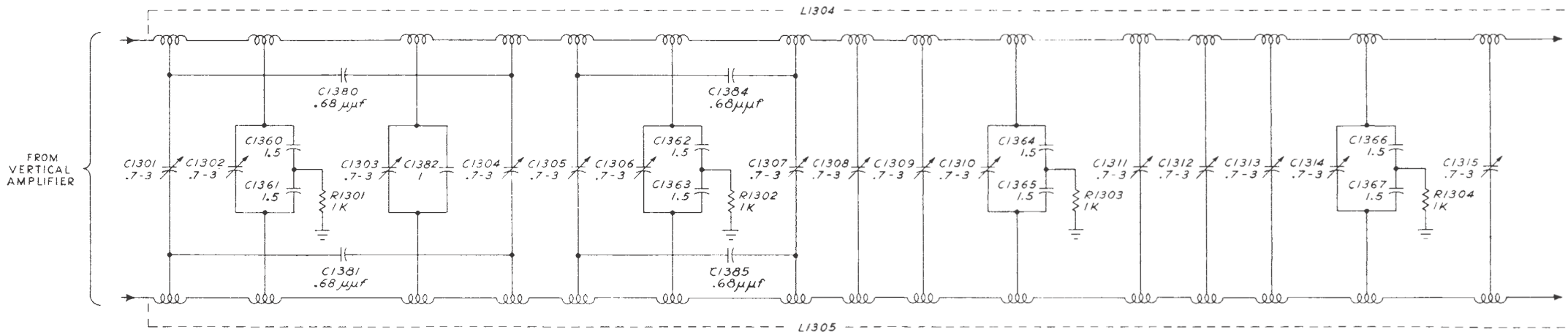

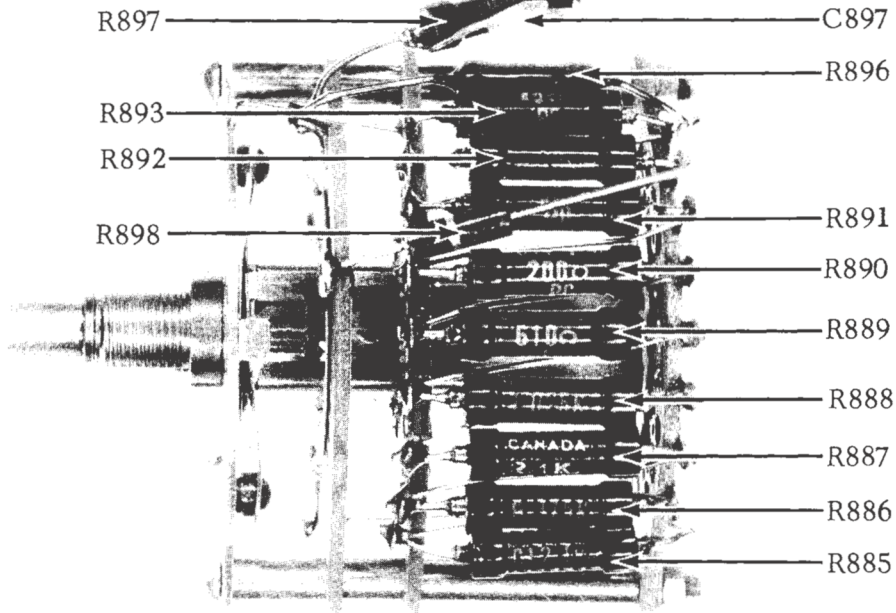

AMPLITUDE CALIBRATOR SWITCH

Bottom View

545A

A

CALIBRATOR MULTIVIBRATOR

CAL. OUT CF

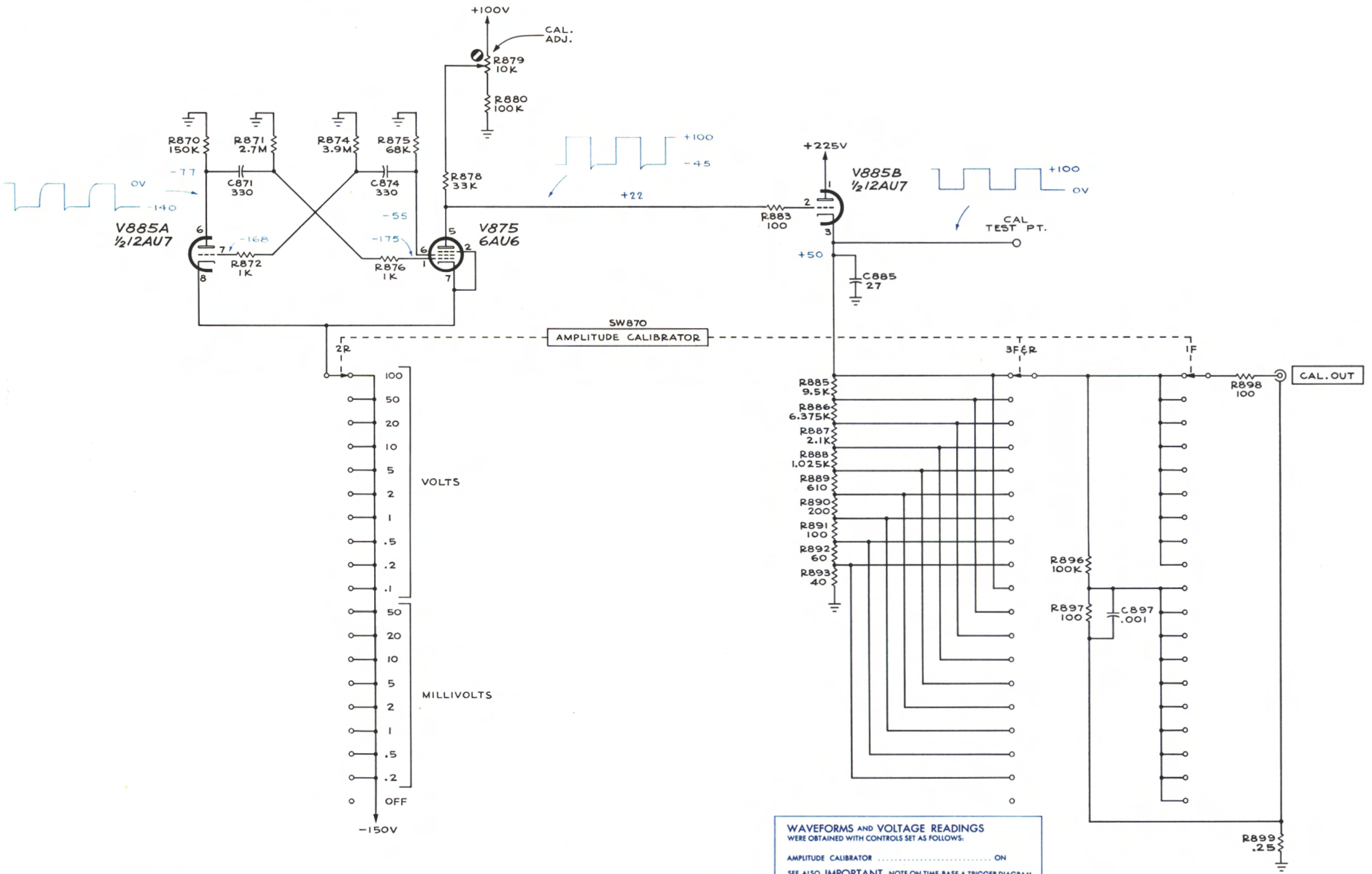

SW870
AMPLITUDE CALIBRATOR

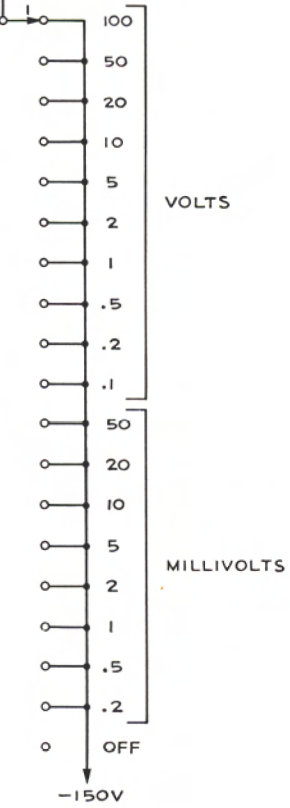

WAVEFORMS AND VOLTAGE READINGS
WERE OBTAINED WITH CONTROLS SET AS FOLLOWS:
AMPLITUDE CALIBRATOR ON
SEE ALSO IMPORTANT NOTE ON TIME-BASE A TRIGGER DIAGRAM

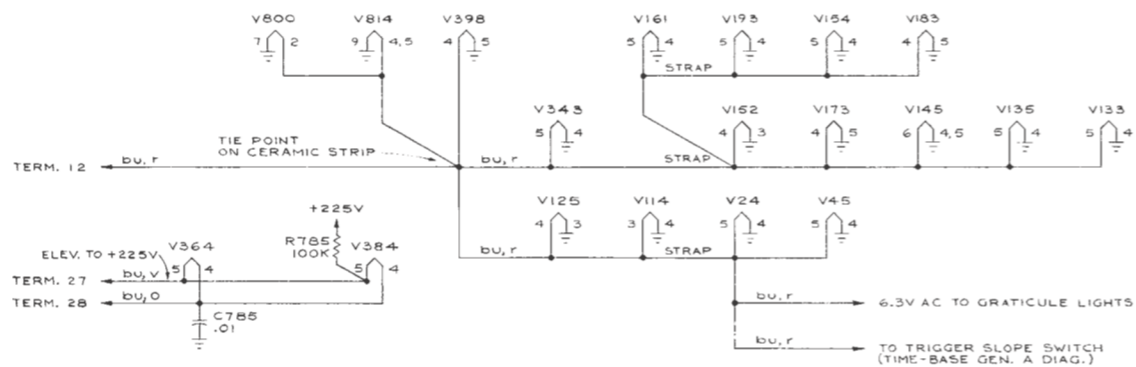

TIME-BASE A CHASSIS

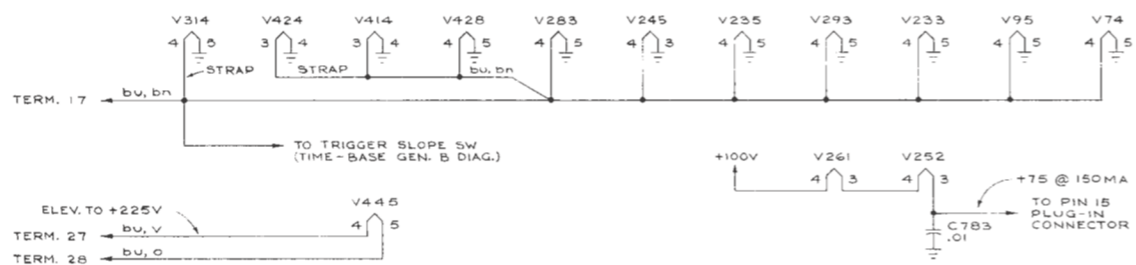

TIME-BASE B CHASSIS

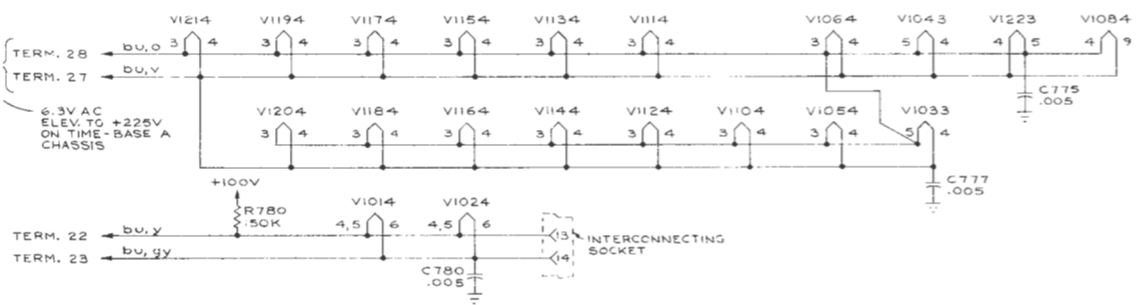

VERTICAL AMPLIFIER CHASSIS

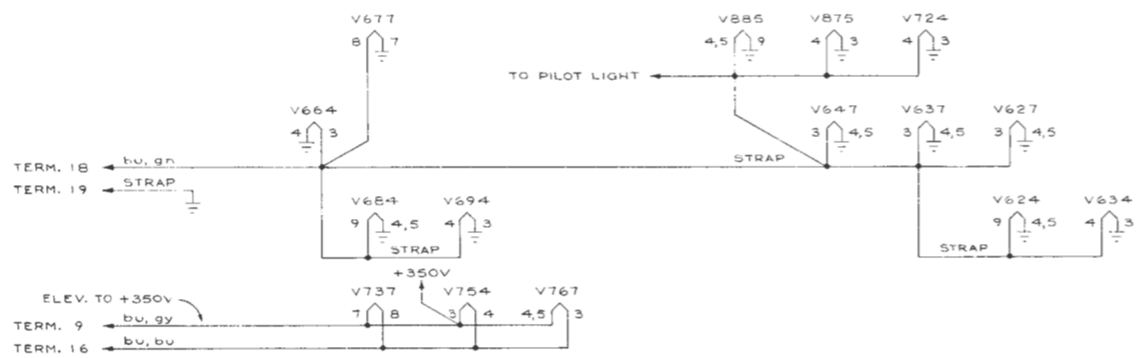

POWER SUPPLY CHASSIS

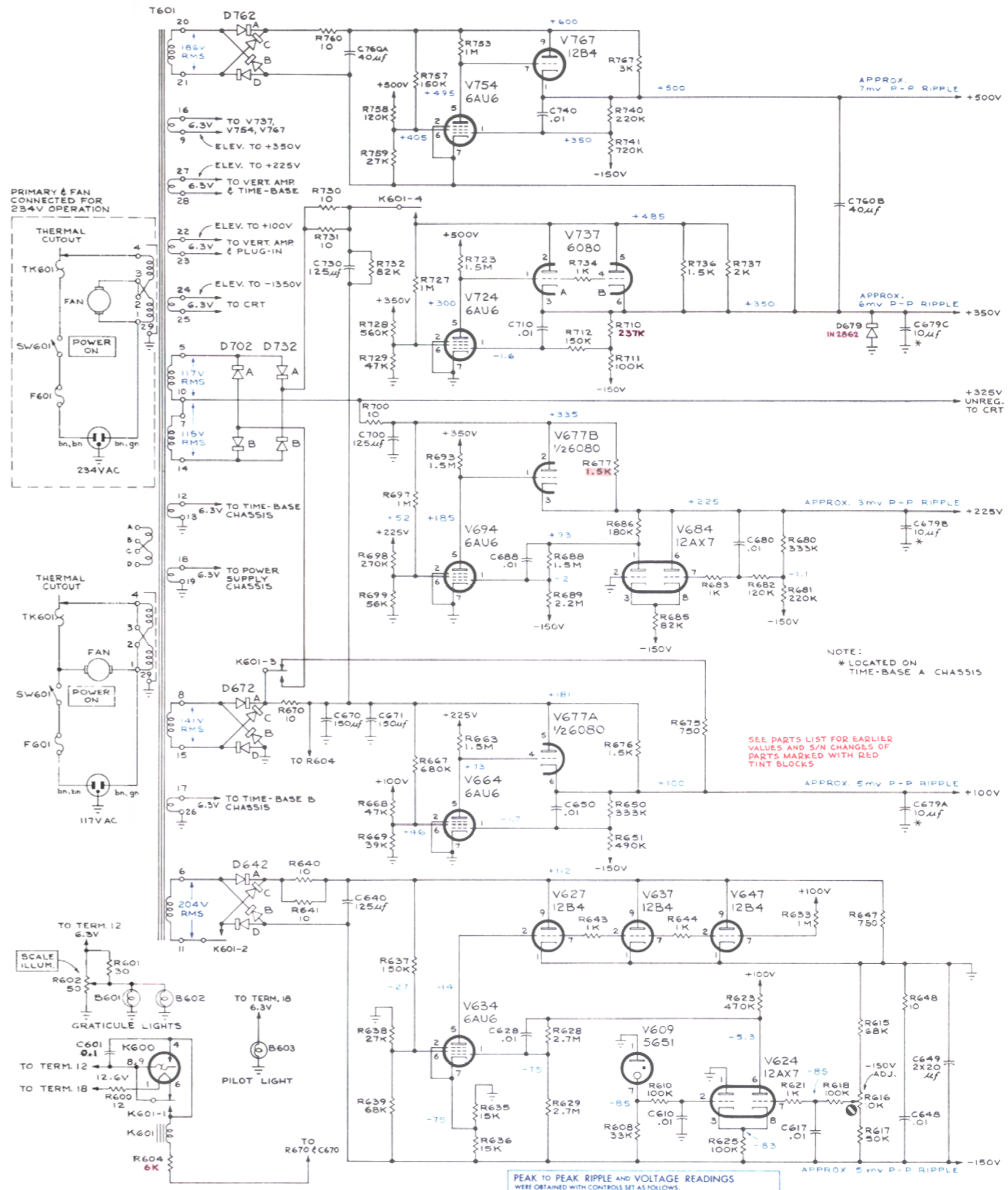

FOR ADDITIONAL SWITCH DETAILS
SEE: HORIZ. AMP. DIAG.
DELAY PICKOFF DIAG.
BLOCK DIAG.

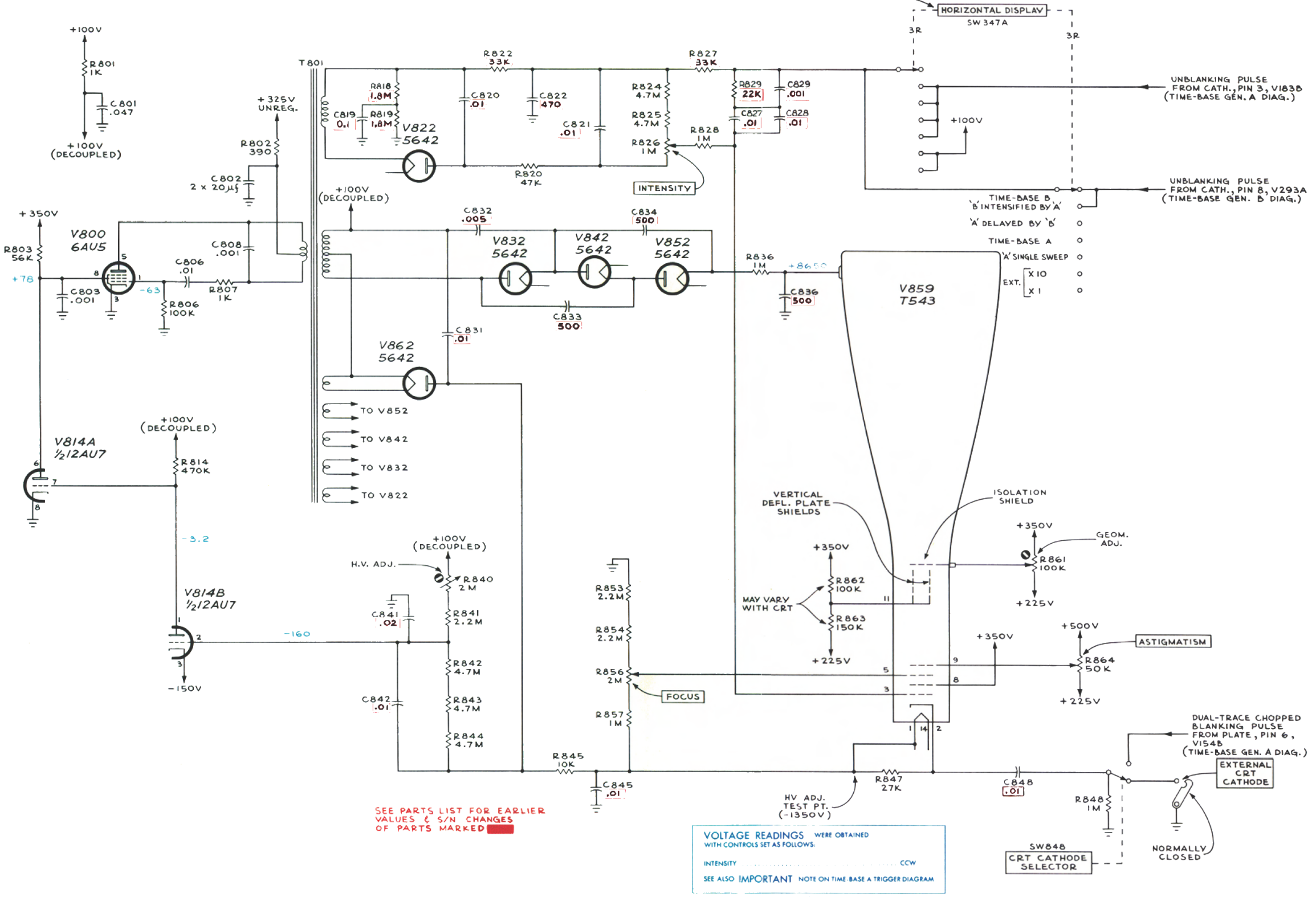

SEE PARTS LIST FOR EARLIER
VALUES & S/N CHANGES
OF PARTS MARKED

VOLTAGE READINGS WERE OBTAINED
WITH CONTROLS SET AS FOLLOWS:
INTENSITY CCW
SEE ALSO IMPORTANT NOTE ON TIME-BASE A TRIGGER DIAGRAM

MANUAL CHANGE INFORMATION

At Tektronix, we continually strive to keep up with latest electronic developments by adding circuit and component improvements to our instruments as soon as they are developed and tested.

Sometimes, due to printing and shipping requirements, we can't get these changes immediately into printed manuals. Hence, your manual may contain new change information on following pages. If it does not, your manual is correct as printed.

TYPE 545A
Direct Replacement

BAR, ALUM, TOP SUPPORT SN24603 change to 381-204

Type	531A	Mod.	3696
	RM31A	Mod.	3697
	535A	Mod.	3700
	RM35A	Mod.	3701
	541A	Mod.	3702
	RM41A	Mod.	3703
	545A	Mod.	3706
	RM45A	Mod.	3707

C841 Changed to .02 μ f Discap 600V 283-006