

Tektronix[®]
COMMITTED TO EXCELLENCE

Instructions

A6303

Current Probe

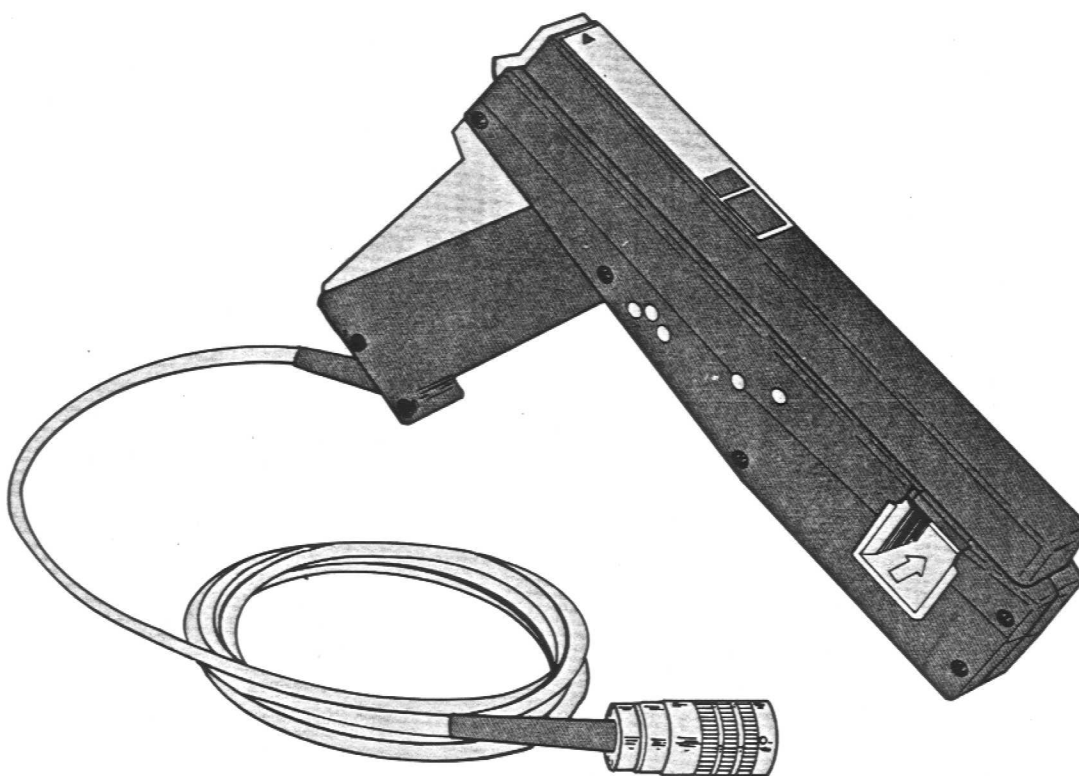

3906-01

DESCRIPTION

The A6303 is a dc to 15 MHz probe capable of measuring currents to 100 A continuous (dc + peak ac). It will also measure up to 500 A peak pulse current if the amp-second rating is not exceeded. The A6303 is designed for use with a current probe amplifier.

A Hall generator device is used in the probe to provide dc and low-frequency current information. Low-frequency (from the Hall device) and high-frequency information (from the current transformer) are combined in the current probe amplifier to produce an accurate representation of the current being measured.

A spring-loaded slide permits the current transformer core to open and close around a conductor. The slide is pushed forward into a closed position and a thumb actuated lock keeps the slide closed for current measurements. A multi-pin connector is provided to permit connection of the probe to a current probe amplifier.

SPECIFICATION

The following instrument specification applies over an ambient range of 0°C to 50°C, providing the instruments were calibrated in an ambient temperature range between +20°C and +30°C. The amplifier and probe must operate for at least 20 minutes before making measurements.

Table 1
ELECTRICAL CHARACTERISTICS

Characteristics	Performance Characteristics	Supplemental Information
Bandwidth	Dc to at least 15 MHz	
Risetime	23 ns or less	
Aberrations	$\leq \pm 5\%$, total not to exceed 7% p-p on 100 MHz oscilloscope system	
Noise	≤ 3 mA measured tangentially	Probe amplifier bandwidth at 100 MHz, coupling in dc, sensitivity 10 mA
Maximum Input Current		
Dc + peak ac		100 A maximum (ac current not to exceed derating curve for continuous operation); see derating curve, Fig. 1
Peak Pulse		500 A maximum for pulses greater than 100 A the pulse amp-sec is not to exceed 10,000 amp/ μ sec
Maximum Voltage on bare conductor being tested		700 V (dc + peak ac)
External Voltage Feedthrough Susceptibility		≤ 2.5 mA/V at 15 MHz

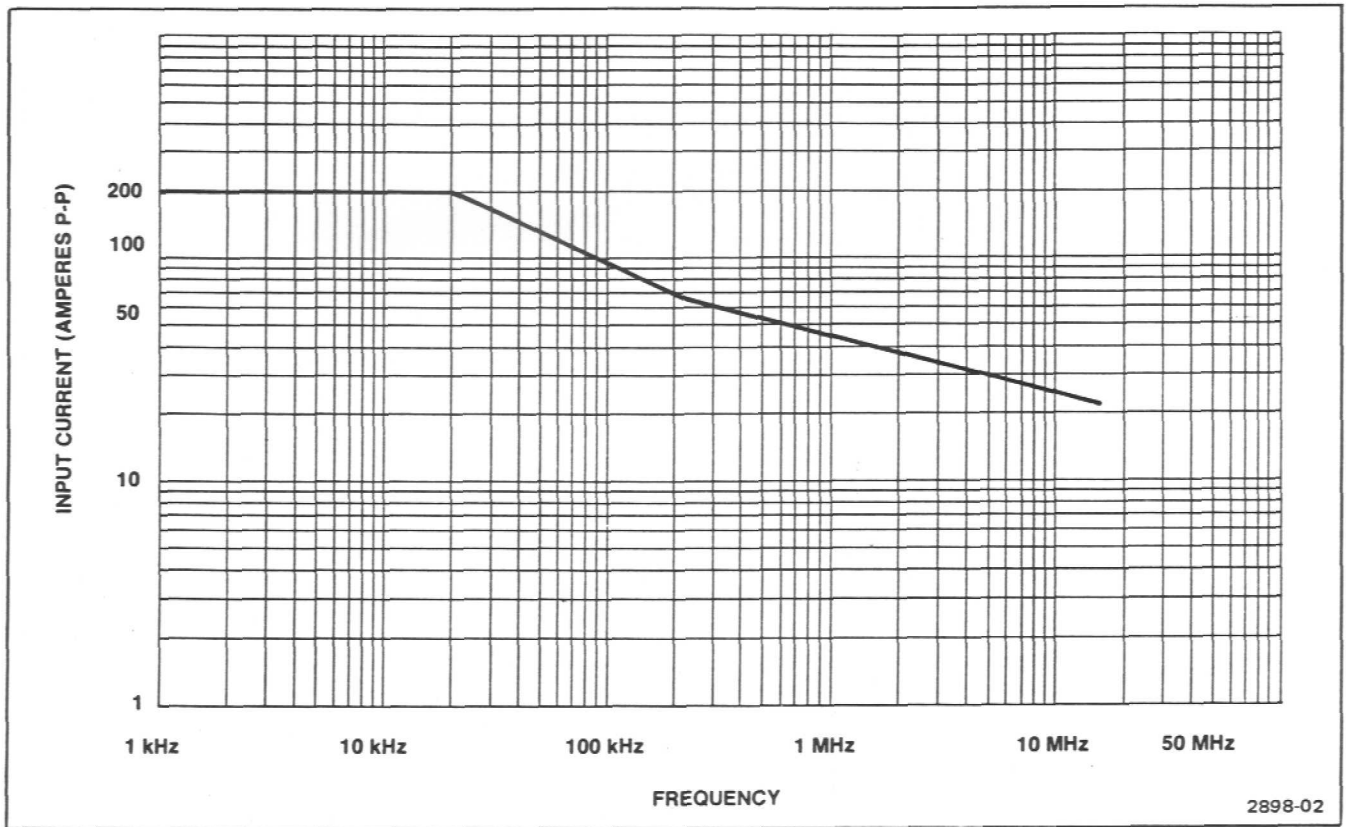

Fig. 1. Maximum input current versus frequency.

Table 2
ENVIRONMENTAL CHARACTERISTICS

Characteristics	Information
Temperature	
Non-Operating (Storage)	-40°C to +75°C.
Operating	0°C to +50°C.
Altitude	
Non-Operating	50,000 feet.
Operating	15,000 feet.

Table 3
PHYSICAL CHARACTERISTICS

Characteristics	Information
Dimensions, Probe Head	
Length	10.5 inches.
Height	6.1 inches.
Width	1.6 inches.
Jaw Size	1.0X0.83 inch, rectangular

OPERATING CONSIDERATIONS

Insertion Impedance

The insertion impedance of the current probe is the equivalent circuit that is placed in the circuit under test when the probe is clamped around a conductor. When observing fast-rise signals, consider the insertion impedance.

Figure 2 shows the relationship of frequency to insertion impedance for A6303 Current Probes.

NOTE

The A6303 Current Probe measures magnetic flux around a conductor, which is caused by current in that conductor. Remember this when reading dc currents in ferrous leads (like transistor leads) that may be magnetized. This lead flux causes erroneous readings in the more sensitive current probe amplifier settings.

Circuit Loading

To minimize loading of critical circuits, clamp the probe at the low or ground end of a component lead whenever possible.

Direction of Current Flow

To display correct polarity, the probe should be clamped around a conductor with the arrow pointing in the direction of conventional current flow (positive to negative).

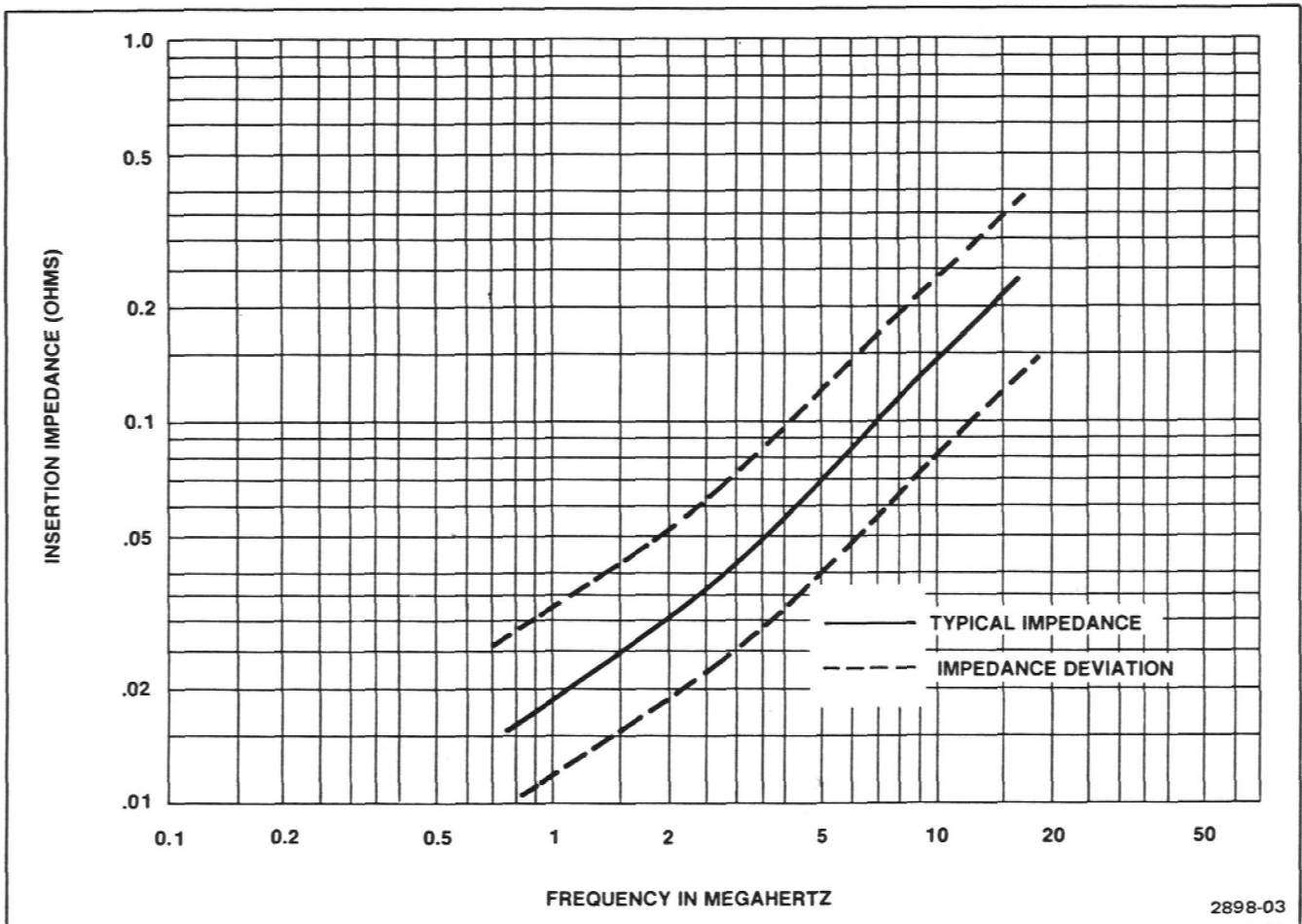

Fig. 2. Insertion impedance versus frequency.

High Currents

When measuring high currents, do not disconnect the probe cable from the current probe amplifier while the probe is clamped around a conductor. With the probe cable disconnected, the high voltage developed in the secondary winding may damage the current probe transformer.



Do not let probe transformer core touch bare conductors. The core is not insulated.

Maximum Input Current

Figure 1 shows the maximum input current in amperes, peak-to-peak, vs. signal frequency. Current is derated for a continuous signal to prevent excessive heat in the probe head.

Connecting the Probe

Connect the probe to the current probe amplifier. When the probe is not in use, leave the slide in the locked position. Prior to use, to remove any magnetic flux present in the probe transformer core, always degauss the probe. To degauss, apply the degauss signal while the current probe is disconnected from any current-carrying conductor. Be sure that the slide is in the locked position. See Fig. 3.

NOTE

The probe may be connected or disconnected with the current probe amplifier turned on. It must be degaussed after being connected or re-connected. It must not be disconnected while it is clamped around a current-carrying conductor.

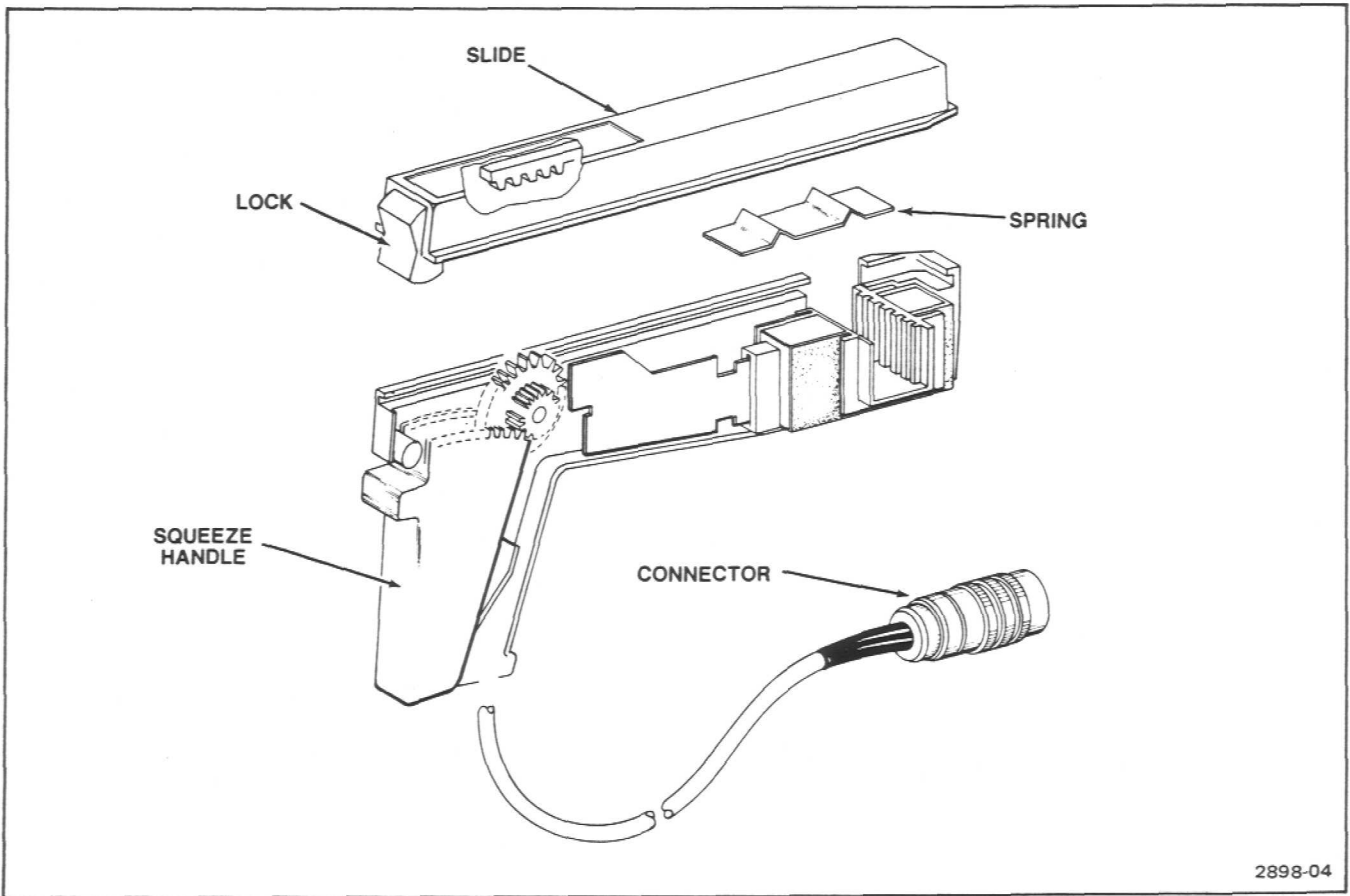

2898-04

Fig. 3. Controls and connectors on A6303.

THEORY OF OPERATION

Detailed Circuit Description

Circuits unique to this instrument are described in detail. A block diagram and schematic are located at the back of this manual. Refer to these drawings throughout the following circuit description.

The Probe

The probe has a stationary core transformer with a secondary winding, a movable core that slides over the end of the stationary core, and a Hall-generator device. The Hall device is a thin rectangular sheet of semiconductor material sandwiched in the stationary portion of the transformer core.

A resistor network in the probe and the dc voltages from pins A and D of the cable connector establish a bias current of approximately 20 mA through the length of the Hall device.

When the probe is coupled around a current-carrying conductor, the magnetic field of the conductor develops a voltage at the Hall device output terminals. The resultant output voltage varies in direct proportion to the current passing through the conductor. When the Hall device is subjected to a low-frequency current, the waveforms at the output terminals are proportional in amplitude. The direction of current flow in the conductor determines the polarity of the output waveform (see Fig. 4).

Because of feedback from the current probe amplifier, the transformer core operates at very low flux densities. This is accomplished by applying the current probe amplifier output voltage to the transformer coil. The current through the coil generates a magnetic flux in the core opposite and approximately equal to the flux generated by the current signal being measured.

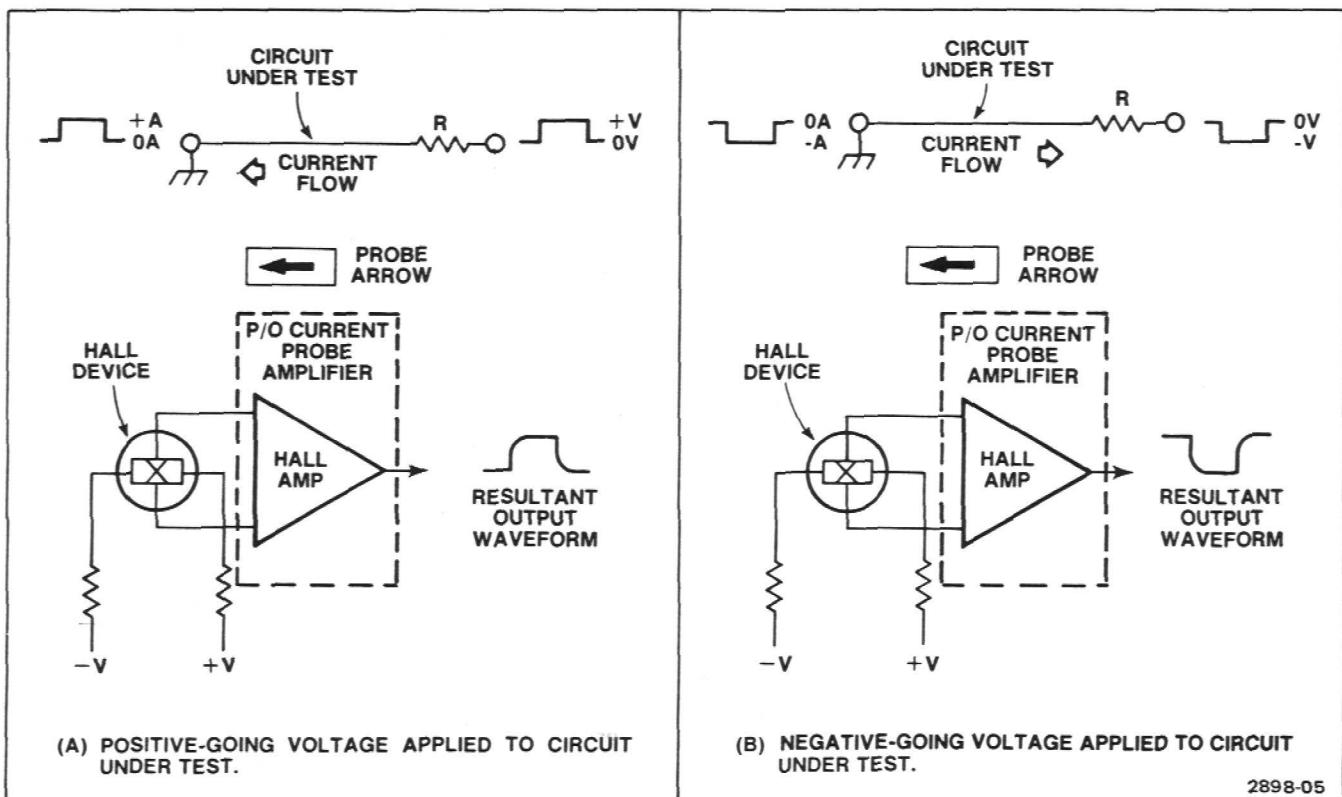

Fig. 4. Output of Hall device related to direction of current flow.

PERFORMANCE CHECK PROCEDURE

Introduction

This procedure checks the electrical characteristics that appear in the Specification portion of this manual. If the instrument fails to meet the requirements given in this performance check, an adjustment procedure should be performed. This procedure can also be used by an incoming inspection facility to determine acceptability of performance.

The electrical characteristics are valid only if the current probe amplifier is calibrated at an ambient temperature of +20°C to +30°C and operated at an ambient temperature of 0°C to +50°C. Forced air circulation for the current probe amplifier is required for ambient temperature above +40°C.

Tolerances that are specified in this performance check procedure apply to the instrument under test and do not include test equipment error.

Test Equipment Required

The following test equipment, or equivalent, is required to perform the performance check. Test equipment characteristics listed are the minimum required to verify the performance of the equipment under test. Substitute equipment must meet or exceed the stated requirements. All test equipment is assumed to be operating within tolerances.

Modification of the test procedure may be required if alternate test equipment is substituted.

Special test devices are used where necessary to facilitate the procedure. Most of these are available from Tektronix, Inc., and can be ordered through your local Tektronix Field Office or representative.

Table 4
TEST EQUIPMENT REQUIRED

Description	Performance Requirements	Application	Examples
Test Oscilloscope	Bandwidth, 150 MHz; vertical deflection, 5 mV/Div; time/div, 2 ms.	All measurements	TEKTRONIX 7704A with 7A16A Amplifier and 7B80 Time Base
Calibration Generator	Pulse Output: period 1 μ s to 10 ms; duty cycle, \approx 50%; amplitude range, 0.5 V or less to at least 5 V. Leading edge aberrations \leq 2% into 50 Ω . Risetime (terminated into 50 Ω) \leq 10 ns.	Risetime, aberrations, noise measurements	TEKTRONIX PG 506 ^a Pulse Generator
Constant Amplitude Sine Wave Generator	Frequency range, to at least 30 MHz with 50 kHz reference frequency amplitude range, to 5.5 V p-p; impedance, 50 Ω ; amplitude accuracy (50 kHz reference) within 3% of indicated amplitude on 5 V range, into 1% termination; flatness, output amplitude does not vary more than 3% from actual amplitude of 50 kHz reference.	Bandwidth checks	TEKTRONIX SG 503 ^a Levelled Sine Wave Generator
Current Probe Amplifier	Bandwidth, 100 MHz; Current/Div accuracy, within 3%	All measurements	TEKTRONIX AM 503 ^a Current Probe Amplifier

Table 4 (cont)
TEST EQUIPMENT REQUIRED

Description	Performance Requirements	Application	Examples
Cable (2 required)	Impedance, 50 Ω ; length, 42 inches; connectors, bnc.	All measurements	Tektronix Part No. 012-0057-01
Termination	Impedance, 50 Ω ; connector, bnc.	All measurements	Tektronix Part No. 011-0049-01
10X Attenuator (2 required)	Attenuation accuracy, $\pm 2\%$; connector, bnc.	Noise check	Tektronix Part No. 011-0059-02
Calibration Fixture (Current Loop)	Impedance, 50 Ω .	All measurements	Tektronix Part No. 067-0865-00

^a Requires TM 500-Series Power Module.

Preliminary Procedure

1. Ensure that all power switches are off.
2. Ensure that all test equipment and the power module into which the current probe amplifier will be installed are suitably adapted to the line voltage to be applied.
3. Install a current probe amplifier into the power module and connect the A6303 Current Probe. Install all other applicable TM 500-Series test equipment into the power module.
4. Connect the power module(s) and test equipment to a suitable line voltage source. Turn all equipment on and allow at least 20 minutes for the equipment to warm up and stabilize.
5. Set the test oscilloscope vertical sensitivity for 10 mV/Div.
6. With the test oscilloscope input coupling switch at ground, position the trace vertically to graticule center. Switch input coupling to dc.
7. Set the current probe amplifier function to adjust the dc level for zero output (trace centered on the test oscilloscope graticule).
8. Set current probe amplifier sensitivity for 10 mA/div.

NOTE

All steps in the Performance Check require the following setup. (See Fig. 5.) With each of the more complex steps, an equipment setup illustration is provided. Titles for front-panel controls and connectors are initial capitals in this procedure (e.g., Current/Div, Balance, etc.).

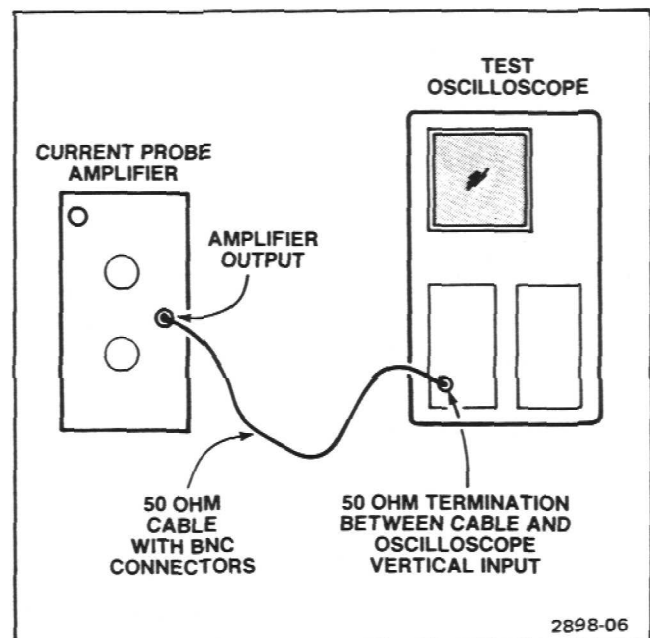

Fig. 5. Setup for preliminary procedure.

A6303 Current Probe

- 9. Momentarily apply degaussing voltage to the probe.
- 10. Set current probe amplifier to dc.

11. Set current probe amplifier dc balance for zero output (trace centered on test oscilloscope graticule).

1. Risetime Check

See Fig. 6 for test setup.

Set controls:

Current Probe Amplifier	
Bandwidth	Full
Current/Div	50 mA
Calibration Generator	
Period	1 μ s
Function	High Amp
Test Oscilloscope	
Volts/Div	5 mV
Input Coupling	dc
Time/Div	200 ns

- a. Adjust calibration generator output for four-division vertical display on test oscilloscope.
- b. Adjust test oscilloscope vertical sensitivity for a five-division display (uncalibrated).
- c. Switch test oscilloscope Time/Div to 5 ns.

d. Measure risetime between 10% and 90% amplitude points.

e. CHECK—for ≤ 23 ns risetime.

2. Aberrations Check

See Fig. 6 for test setup.

Set controls:

Calibration Generator	
Function	High Amp
Period	1 μ s
Current Probe Amplifier	
Bandwidth	Full
Current/Div	50 mA
Test Oscilloscope	
Time/Div	.2 ms
Volts/Div	5 mV
Input Coupling	dc

- a. Set calibration generator for 4 Div display.
- b. Adjust test oscilloscope vertical sensitivity for a five-division display (uncalibrated).
- c. CHECK—to display flat within $\pm 5\%$; total aberrations $\leq 7\%$ peak to peak.

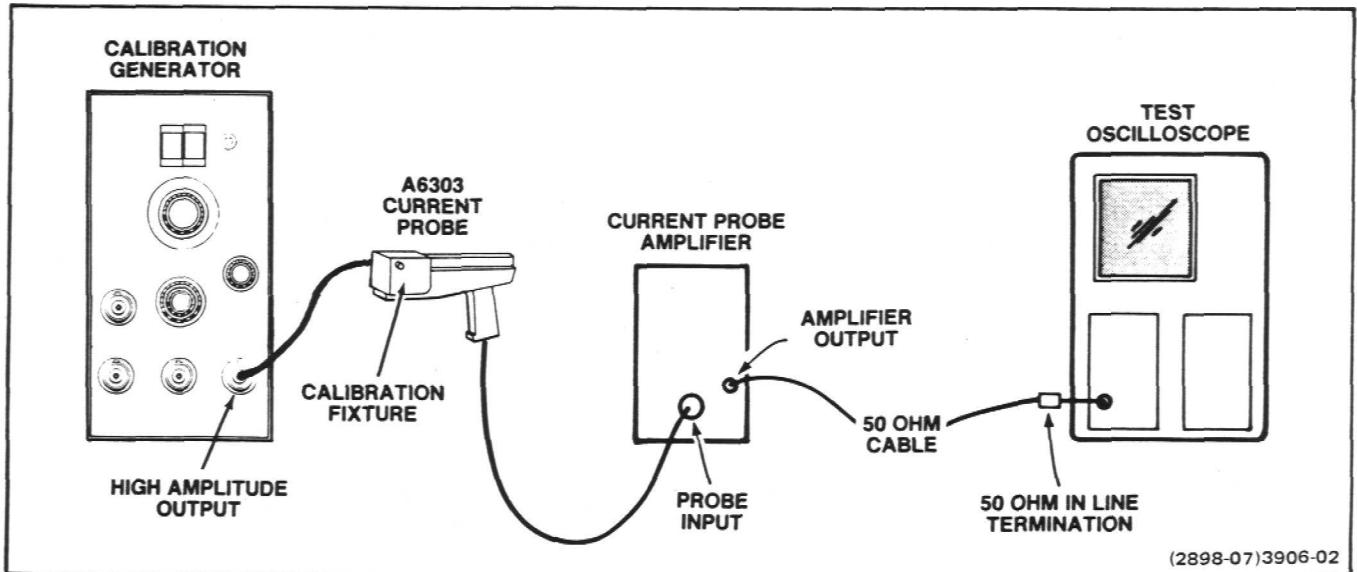

Fig. 6. Test setup for risetime check.

3. Noise Check

See Fig. 8 for test setup.

Set Controls:

Current Probe Amplifier

Current/Div 10 mA
 Bandwidth Full

Test Oscilloscope

Time/Div 0.1 ms
 Volts/Div 10 mV

Calibration Generator

Frequency 1 kHz
 Function High Amplitude

a. Adjust calibration generator amplitude until two free-running traces just merge (no dark area between traces). See Fig. 9.

b. Remove one 5X attenuator.

c. Measure the display amplitude on the test oscilloscope. Divide display amplitude by 5.

Example: one division of display at 10 mV/Div = 10 mV (equivalent to 10 mA), divided by 5 = 2.0 mA of noise, measured tangentially.

d. CHECK—for ≤ 3 mA maximum noise, measured tangentially.

4. Bandwidth Check

See Fig. 10 for test setup.

Set controls:

Current Probe Amplifier

Bandwidth Full
 Current/Div 10 mA

Test Oscilloscope

Volts/Div 10 mV

Sine Wave Generator

Frequency 50 kHz reference

a. Set constant amplitude sine-wave generator amplitude for six division display on test oscilloscope.

b. Increase constant amplitude sine-wave generator frequency until test oscilloscope vertical display amplitude decreases to 4.2 divisions.

c. CHECK—that constant amplitude sine-wave generator frequency is 15 MHz or greater.

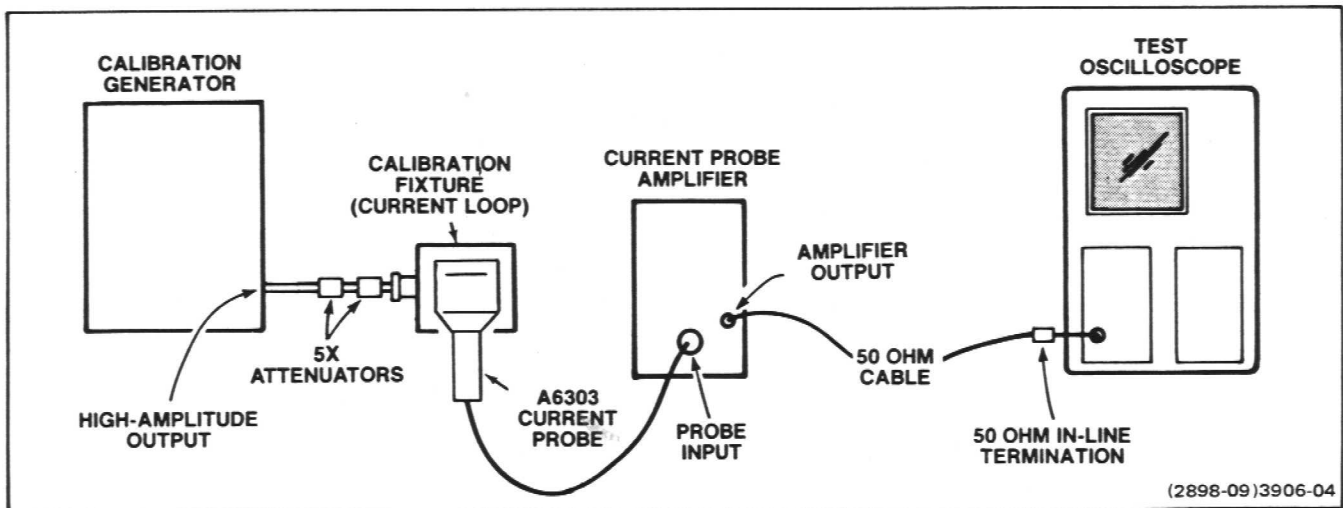

Fig. 8. TEST SETUP for noise check.

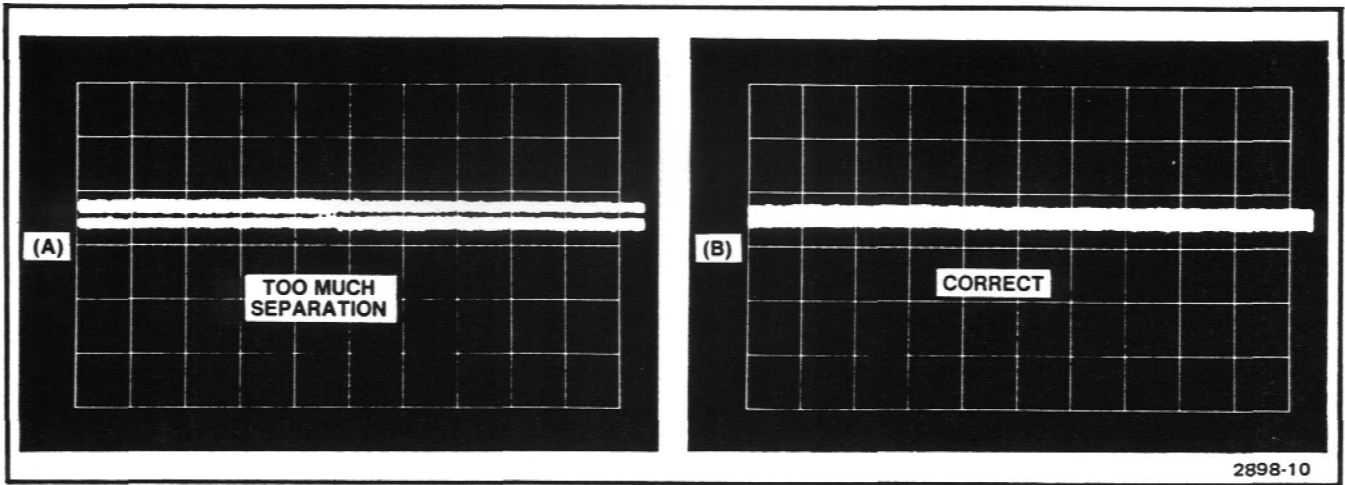

Fig. 9. Display of tangentially-measured noise (A) incorrect; dark area showing between traces, (B) correct display.

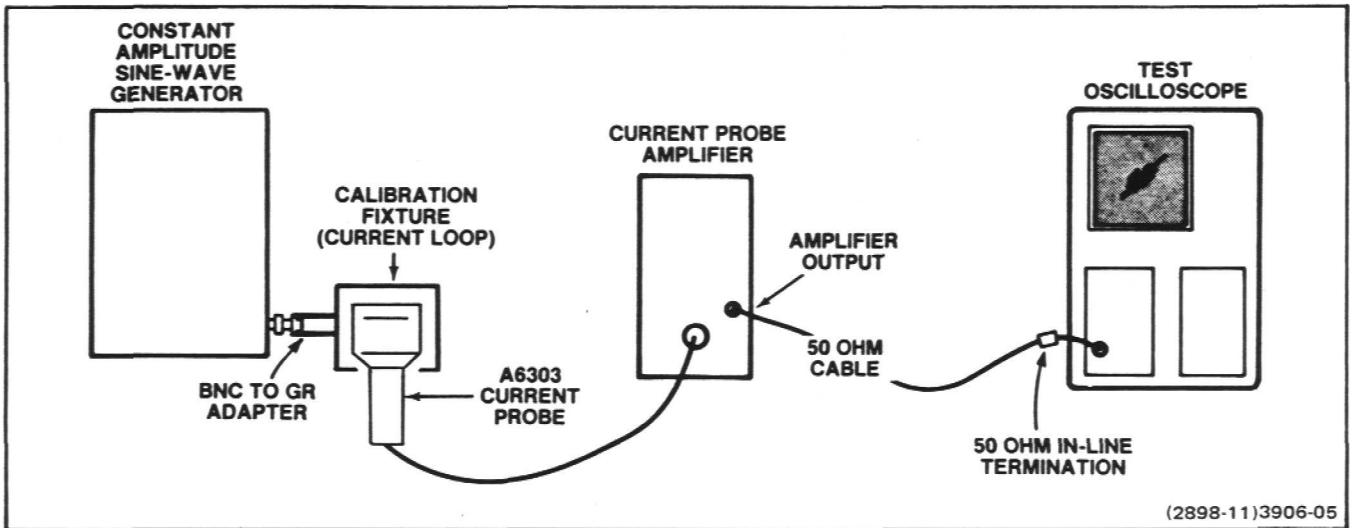

Fig. 10. Test setup for bandwidth check.

ADJUSTMENT PROCEDURE

Introduction

This section contains information necessary to perform complete instrument adjustments. This procedure is not intended as a troubleshooting guide, and any trouble found during adjustment should be corrected before continuing. Refer to Maintenance for further information.

Adjustment Interval

To maintain instrument accuracy, check the performance of the A6303 every 1000 hours of operation, or every six months if used infrequently.

Tektronix Field Service

Tektronix field Service Centers and the Factory Service Center provide instrument repair and adjustment service. Contact your local Tektronix Field Office or representative for further information.

Using the Procedure

Completion of each step in this procedure ensures that the instrument is correctly adjusted and operating within the specified limits. A partial adjustment may be desirable after replacing components, or to touch up the adjustment of a portion of the instrument.

Test Equipment Required

The test equipment listed in Table 5, or equivalent, is required for adjustment of the A6303. Specifications given for the test equipment are the minimum necessary for accurate adjustment and measurement. All test equipment is assumed to be correctly calibrated and operating within specification.

If other test equipment is substituted, control settings or calibration setup may need to be altered to meet the requirements of the equipment used.

Table 5
TEST EQUIPMENT REQUIRED

Description	Performance Requirements	Application	Example
Test Oscilloscope	Bandwidth, 150 MHz; vertical deflection, 5 mV/Div; Time/Div, 2 ms.	All measurements.	TEKTRONIX 7704A with 7A16A Amplifier and 7B80 Time Base.
Calibration Generator	Pulse output; period 1 μ s to 10 ms duty cycle, \approx 50%; amplitude, 5 V p-p, into 50 Ω .	Adjust compensation.	TEKTRONIX PG 506 ^a Pulse Generator.
Current Probe Amplifier	Bandwidth 100 MHz; risetime, 3.5 ns or less.	All measurements.	TEKTRONIX AM 503 ^a current probe amplifier.
Cable (2 required)	Impedance, 50 Ω ; length, 42 inches; connectors, bnc.	All measurements.	Tektronix Part No. 012-0057-01.
Termination	Impedance, 50 Ω ; connector, bnc.	All measurements.	Tektronix Part No. 011-0049-01.
Calibration Fixture (Current loop)	Impedance, 50 Ω ; connector, bnc.	All measurements.	Tektronix Part No. 067-0865-00.

^a Requires TM 500-Series Power Module.

A6303 Current Probe

1. Adjust Offset

a. Install the current probe amplifier into the power module and connect the A6303 Current Probe. Install all other applicable TM 500-Series test equipment into the power module.

b. Connect the power module(s) and test equipment to a suitable line voltage source. Turn all equipment on and allow at least 20 minutes for the equipment to warm up and stabilize.

c. Connect the current probe amplifier output through a 50 Ω cable and 50 Ω termination to the test oscilloscope vertical input.

d. Set the test oscilloscope vertical sensitivity for 10 mV/Div.

e. With the test oscilloscope input coupling switch at ground, position the trace vertically to graticule center. Switch input coupling to dc.

f. Set the current probe amplifier function to adjust the dc level for zero output (trace centered on the test oscilloscope graticule).

g. Set current probe amplifier sensitivity for 10 mA/Div.

h. Momentarily apply degaussing voltage to the probe.

i. Set current probe amplifier to dc.

j. Set current probe amplifier balance to mid-position.

k. Remove plug on A6303 to access R45. (Refer to Fig. 11.)

l. ADJUST—R45 to bring trace to test oscilloscope graticule center.

m. Momentarily apply degaussing voltage to the probe.

n. If necessary, re-adjust R45 to bring trace to test oscilloscope graticule center.

o. Replace plug over R45 access hole.

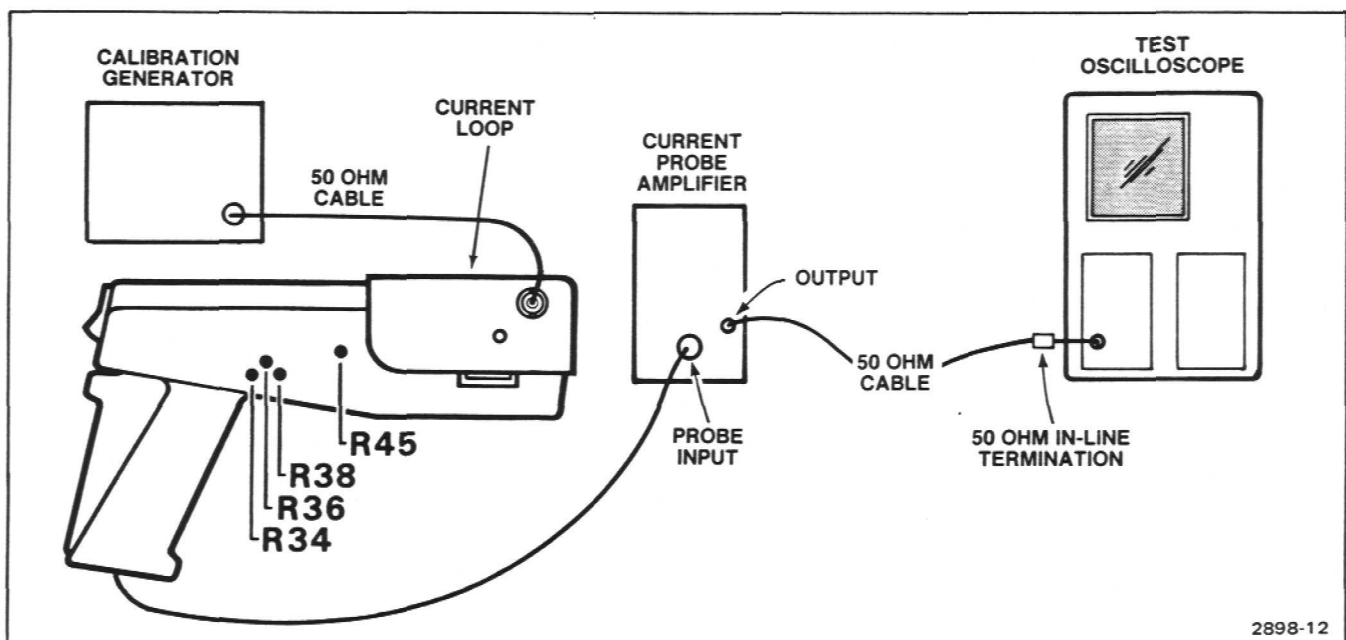

Fig. 11. Test setup for transient response adjustment.

2. Adjust Transient Response

Preliminary settings:

Test Oscilloscope

Volts/Div 1 V
 Input Coupling dc
 Time/Div 50 μ s

Calibration Generator

Period 0.1 ms
 Function High Amp

a. Connect the calibration generator High Amplitude Output through a 50 Ω cable and 50 Ω termination to the test oscilloscope Vertical input.

b. Set the calibration generator amplitude for a vertical amplitude of 5 divisions (5 volts).

NOTE

Do not change the calibration generator amplitude for the remainder of this procedure.

c. Connect equipment as shown in Fig. 11.

d. Set controls:

Current Probe Amplifier

Bandwidth Full
 Current/Div 50 mA

Test Oscilloscope

Volts/Div 5 mV
 Time/Div 5 ms

Calibration Generator

Period 10 ms
 Function High Amp

e. Remove plugs on A6303 to access R34, R36, and R38. (Refer to Fig. 11).

f. ADJUST—R38 for a four-division display.

g. Change the calibration generator frequency to 1 kHz.

h. ADJUST—R34 and R36 for optimum transient response.

i. Use Table 6 for completing the adjustments.

NOTE

After replacing components, it may be necessary to add or remove L38 beads to adjust the transient response.

**Table 6
 TRANSIENT RESPONSE ADJUSTMENTS**

Adjustment	Repetition Rate	Period	Test Oscilloscope Sweep Speed
R38	1 kHz	1 ms	200 μ s
R38	100 Hz	10 ms	2 ms
R36	100 kHz	.1 ms	2 μ s
R34	100 kHz	.1 ms	2 μ s

NOTE

The adjustments interact and may require readjusting for optimum transient response with the proper gain.

MAINTENANCE

CLEANING

Dirt that accumulates on the probe head can be removed with a soft cloth dampened in a mild detergent and water solution. Abrasive cleaners should not be used.



Avoid the use of chemical cleaning agents which might damage the plastics used in this instrument. In particular, avoid chemicals which contain benzene, toluene, xylene, acetone, or similar solvents.

Recommended cleaning agents are isopropyl alcohol (Isopropanol) or ethyl alcohol (Fotocol or Ethanol).

SERVICING

The following servicing instructions are for use by qualified personnel only. To avoid personal injury do not perform any servicing other than that contained in Operating Considerations unless you are qualified to do so.

Obtaining Replacement Parts

Most electrical and mechanical parts can be obtained through your local Tektronix field Office or representative. Before you purchase or order a part from a source other than Tektronix, Inc., please check the Replaceable Electrical Parts list for the proper value, rating, tolerance, and description.

Lubrication

Do not lubricate the gap between the stationary and movable transformer core pieces. Any lubricant between the core pieces should be removed with a recommended cleaning agent.

Slide Switch. This switch is lubricated before leaving the factory. Should the switch become noisy, clean and lubricate with a switch cleaning lubricant.

Movable Plastic Parts. Should the plastic slide assembly require lubrication, apply silicone-based grease sparingly to the plastic.

Probe Disassembly (see Fig. 12)

1. Lock the slide.
2. Place the probe on a flat surface with the screw heads facing up.
3. Remove the eight retaining screws from the case.
4. While holding the slide and squeeze-handle, lift the top part of the probe body off.
5. If desired, remove the slide.



There is a spring in the handle that can pop out and cause injury unless proper precautions are used in disassembling the probe.

6. You can now release the slide and the squeeze-handle.



Cover the handle area with a cloth to restrict travel of the spring, should it accidentally come out.

Probe Assembly (see Fig. 12)



There is a spring in the handle that can pop out and cause injury unless proper precautions are used in assembling the probe.

1. Assemble the squeeze-handle and torsion spring in the left part of the probe body. (The left part has two terminals with the interconnecting cable attached. It also has the threaded holes for the eight retaining screws.)

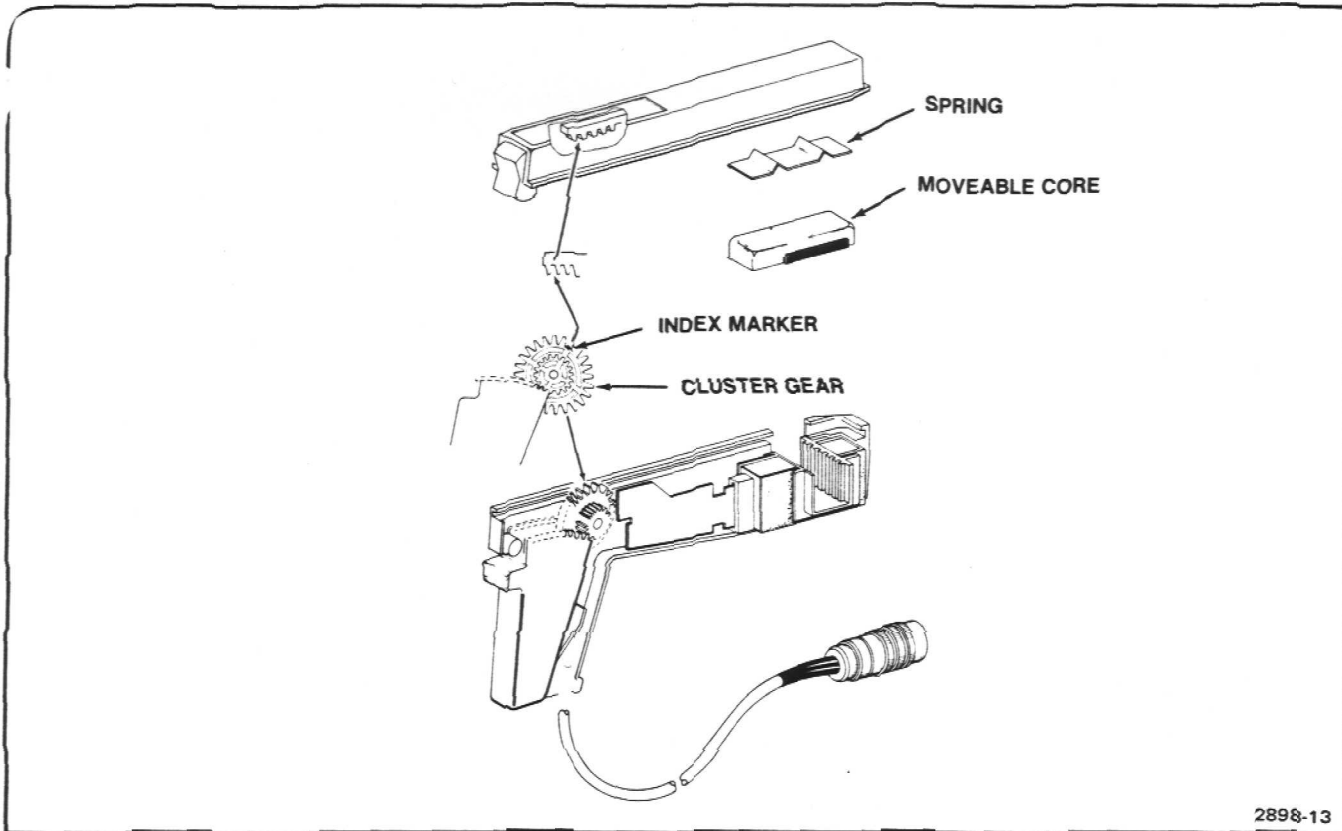

Fig. 12. Probe cluster gear and transformer assembly.

2. Install the cluster gear as follows:
 - a. Take the cluster gear and note the index mark on the larger gear. The teeth of the large and small gears are in line at the index mark and 180° from the index.
 - b. On the small gear, find the in-line-tooth that is 180° from the index mark.
 - c. Place the cluster gear on its axle (a post protruding up from the probe body). The larger gear fits between the two gear segments on the top of the squeeze-handle. Engage the tooth mentioned in part b with the first groove of the squeeze-handle as shown in Fig. 12.
3. Install the cable assembly and the circuit board.
4. Plug the circuit board into the transformer assembly.
5. Place the transformer assembly in the probe body. (Ensure transformer is pressed all the way down.)
6. Install the spring and the top of the transformer core in the slide.
7. Loosen the screws that hold the lock-bar retainer.
8. Place the lock in the unlocked position.
9. Push the lock-bar retainer against the transformer.
10. Tighten the lock-bar retainer screws.
11. Place the slide, while moving the squeeze-handle, so the indexed tooth on the large gear engages the first groove on the gear rack in the slide (see Fig. 12).
12. Install the right part of the probe body as follows:
 - a. Insert the axle for the cluster gear into the hole in the gear.

A6303 Current Probe

b. Press the probe body halves together in the front of the probe and in the gear-axle area. (Ensure that the probe cable and bushing are properly in the groove.)

13. Install the eight retaining screws.

NOTE

The transformer assembly (T5), when ordered, comes with an offset resistor (R43). The polarity marking (+ or -) on the tape attached to the transformer indicates which bias resistor position it will be tied to (A is +, B is -).

This concludes the assembly.

CROSS INDEX—MFR. CODE NUMBER TO MANUFACTURER

Mfr. Code	Manufacturer	Address	City, State, Zip
00853	SANGAMO ELECTRIC CO., S. CAROLINA DIV.	P.O. BOX 128	PICKENS, SC 29671
01121	ALLEN-BRADLEY COMPANY	1201 2ND STREET SOUTH	MILWAUKEE, WI 53204
32997	BOURNS, INC., TRIMPOT PRODUCTS DIV.	1200 COLUMBIA AVE.	RIVERSIDE, CA 92507
51642	CENTRE ENGINEERING INC.	2820 E COLLEGE AVENUE	STATE COLLEGE, PA 16801
56289	SPRAGUE ELECTRIC CO.	87 MARSHALL ST.	NORTH ADAMS, MA 01247
73138	BECKMAN INSTRUMENTS INC., HELIPOT DIV.	2500 HARBOR BLVD.	FULLERTON, CA 92634
76493	BELL INDUSTRIES, INC.		
	MILLER, J. W., DIV.	19070 REYES AVE., P O BOX 5825	COMPTON, CA 90224
80009	TEKTRONIX, INC.	P O BOX 500	BEAVERTON, OR 97077
000AH	STANDARD PRESSED STEEL CO., UNBRAKO DIV.	8535 DICE ROAD	SANTA FE SPRINGS, CA 90670
000BK	STAUFFER SUPPLY	105 SE TAYLOR	PORTLAND, OR 97214
000CY	NORTHWEST FASTENER SALES, INC.	7923 SW CIRRHUS DRIVE	BEAVERTON, OR 97005
02768	ILLINOIS TOOL WORKS, INC., FASTEX DIV.	195 ALGONQUIN ROAD	DES PLAINES, IL 60016
12360	ALBANY PRODUCTS CO., DIV. OF PNEUMO DYNAMICS CORPORATION	145 WOODWARD AVENUE	SOUTH NORWALK, CT 06586
80009	TEKTRONIX INC.	P O BOX 500	BEAVERTON, OR 97077
83385	CENTRAL SCREW CO.	2530 CRESCENT DR.	BROADVIEW, IL 60153
86928	SEASTROM MFG. COMPANY INC.	701 SONORA AVENUE	GLENDALE, CA 91201

A6303 Current Probe

Ckt No.	Tektronix Part No.	Serial/Model No. Eff	Dscont	Name & Description	Mfr Code	Mfr Part Number
REPLACEABLE ELECTRICAL PARTS						
A1	670-4354-00			CKT BOARD ASSY:PROBE	80009	670-4354-00
C13	283-0111-00			CAP.,FXD,CER DI:0.1UF,20%,50V	56289	273C11
C17	283-0111-00			CAP.,FXD,CER DI:0.1UF,20%,50V	56289	273C11
C27	283-0644-00			CAP.,FXD,MICA D:150PF,1%,500V	00853	D155F151F0
C33	283-0647-00			CAP.,FXD,MICA D:70PF,1%,100V	00853	D155E700F0
C38	283-0212-00			CAP.,FXD,CER DI:2UF,20%,50V	51642	400-050-Z5U205M
C41	283-0176-00			CAP.,FXD,CER DI:0.0022UF,20%,50V	56289	272C5
L33	108-0226-00			COIL,RF:100UH	76493	DWG B4257
L34	108-0240-00			COIL,RF:FIXED,820UH	76493	B5147
L38	276-0543-00			SHLD BEAD,ELEK:FERRITE	80009	276-0543-00
L38	----			(NOMINAL VALUE SELECTED-3 BEADS)		
LR30	108-0916-00			COIL,RF:FIXED,615NH	80009	108-0916-00
LR32	108-0917-00			COIL,RF:FIXED,275NH	80009	108-0917-00
R10	317-0681-00			RES.,FXD,CMPSN:680 OHM,5%,0.125W	01121	BB6815
R12	317-0681-00			RES.,FXD,CMPSN:680 OHM,5%,0.125W	01121	BB6815
R13	317-0332-00			RES.,FXD,CMPSN:3.3K OHM,5%,0.125W	01121	BB3325
R14	317-0681-00			RES.,FXD,CMPSN:680 OHM,5%,0.125W	01121	BB6815
R16	317-0681-00			RES.,FXD,CMPSN:680 OHM,5%,0.125W	01121	BB6815
R17	317-0332-00			RES.,FXD,CMPSN:3.3K OHM,5%,0.125W	01121	BB3325
R18	317-0681-00			RES.,FXD,CMPSN:680 OHM,5%,0.125W	01121	BB6815
R20	317-0681-00			RES.,FXD,CMPSN:680 OHM,5%,0.125W	01121	BB6815
R22	317-0202-00			RES.,FXD,CMPSN:2K OHM,5%,0.125W	01121	BB2025
R26	317-0101-00			RES.,FXD,CMPSN:100 OHM,5%,0.125W	01121	BB1015
R34	311-1757-00			RES.,VAR,NONWIR:2.5K OHM,10%,0.50W	32997	3326H-G48-252
R35	----			SELECTED		
R36	311-1757-00			RES.,VAR,NONWIR:2.5K OHM,10%,0.50W	32997	3326H-G48-252
R37	317-0101-00			RES.,FXD,CMPSN:100 OHM,5%,0.125W	01121	BB1015
R38	311-1757-00			RES.,VAR,NONWIR:2.5K OHM,10%,0.50W	32997	3326H-G48-252
R41	317-0270-00			RES.,FXD,CMPSN:27 OHM,5%,0.125W	01121	BB2705
R43	----			SELECTED		
R43	----			(AVAILABLE UNDER 120-1102-00 ONLY,SEE T5)		
R45	311-0607-00			RES.,VAR,NONWIR:10K OHM,10%,0.50W	73138	82-25-2
R46	317-0104-00			RES.,FXD,CMPSN:100K OHM,5%,0.125W	01121	BB1045
T5	120-1102-00			TRANSFORMER,CUR:TOP AND BOTTOM	80009	120-1102-00
T5	----			(SELECTED WITH R43)		
T10	120-0459-00			XFMR,TOROID:10 TURNS,BIFILAR	80009	120-0459-00
T12	120-0459-00			XFMR,TOROID:10 TURNS,BIFILAR	80009	120-0459-00
T14	120-0459-00			XFMR,TOROID:10 TURNS,BIFILAR	80009	120-0459-00
T15	120-1081-00			TRANSFORMER,RF:COMMON MODE FILTER	80009	120-1081-00
T16	120-0459-00			XFMR,TOROID:10 TURNS,BIFILAR	80009	120-0459-00
T18	120-0459-00			XFMR,TOROID:10 TURNS,BIFILAR	80009	120-0459-00
T20	120-0459-00			XFMR,TOROID:10 TURNS,BIFILAR	80009	120-0459-00
T21	120-1082-00			TRANSFORMER,RF:TOROID	80009	120-1082-00
T23	120-1082-00			TRANSFORMER,RF:TOROID	80009	120-1082-00
T25	120-1082-00			TRANSFORMER,RF:TOROID	80009	120-1082-00

A6303 Current Probe

Fig. & Index No.	Tektronix Part No.	Serial/Model No. Eff	Dscont	Qty	1	2	3	4	5	Name & Description	Mfr Code	Mfr Part Number
REPLACEABLE MECHANICAL PARTS												
1-	A6303			1						PROBE,CURRENT:	80009	A6303
-1	204-0712-01			1						.BODY HALF,PROBE:RIGHT W/CONTACTS(ATTACHING PARTS).....	80009	204-0712-01
-2	211-0183-00			2						.SCREW,MACHINE:4-40 X 0.50 INCH,SOC HEX HD	000AH	OBD
-3	211-0093-00			6						.SCR,CAP,SOC HD:4-40 X 0.75 INCH L,STL	000BK	OBD
-4	348-0023-00			4						.PLUG,HOLE:(END ATTACHING PARTS).....	02768	207090201000101
-5	351-0481-01			1						.SLIDE,LOCK BAR:W/CONTACTS	80009	351-0481-01
	351-0549-01			1						.SL ASSY,PROBE:	80009	351-0549-01
-6	105-0717-00			1						.LATCH,THUMB:ROCKER(ATTACHING PARTS).....	80009	105-0717-00
-7	211-0668-00			2						.SCREW,CAP:2-56 X 0.188,HEX SCH,STEEL(END ATTACHING PARTS).....	000CY	OBD
-8	214-2421-00			1						.PIN,STR,HDLS:0.094 DIA X 0.845 L,SST,PSV	80009	214-2421-00
-9	214-2420-00			1						.PIN,ROCKER:0.156 DIA X 0.745 L,SST PSV	80009	214-2420-00
-10	343-0621-00			1						.RTNR,LOCK BAR:(ATTACHING PARTS).....	80009	343-0621-00
-11	211-0182-00			2						.SCR,ASSEM WSHR:2-56 X 0.312 INCH,PNH,STL(END ATTACHING PARTS).....	12360	OBD
-12	214-2422-00			1						.SPRING,FLAT:UPPER CAN	80009	214-2422-00
-13	334-4347-00			1						.MARKER,IDENT:MKD A6303	80009	334-4347-00
-14	351-0482-01			1						.SLIDE,PROBE:TEK BLUE PC	80009	351-0482-01
-15	367-0218-00			1						.HANDLE,SQUEEZE:PROBE	80009	367-0218-00
-16	214-2446-00			1						.SPR,HLCL,TRSN:0.1 OD X 0.5 L,MUSIC WIRE	80009	214-2446-00
-17	401-0352-00			1						.GR CLUSTER,SPUR:(2)18 & (1)24 T,PLASTIC	80009	401-0352-00
-18	----			1						.TRANSFORMER,CUR:TOP & BOTTOM(SEE T5 REPL)		
-19	----			-						.CKT BOARD ASSY:PROBE(SEE A1 REPL)		
-20	352-0480-00			1						.HOLDER,TOROID:(ATTACHING PARTS).....	80009	352-0480-00
-21	211-0121-00			1						.SCR,ASSEM WSHR:4-40 X 0.438 INCH,PNH BRS	83385	OBD
-22	210-0551-00			1						.NUT,PLAIN,HEX:4-40 X 0.25 INCH,STL	000BK	OBD
-23	210-1275-00			1						.WASHER,FLAT:0.128 ID X 0.32 THK,FIBRE(END ATTACHING PARTS).....	86928	5602-62-32
-24	175-2001-01			1						.CA ASSY,SP,ELEC:6,30 AWG,2,50 OHM COAX	80009	175-2001-01
	343-0149-00			1						.CLAMP,LOOP:NYLON	80009	343-0149-00
-25	204-0713-01			1						.BODY HALF,PROBE:LEFT W/CONTACTS	80009	204-0713-01
STANDARD ACCESSORIES												
	070-3906-01			1						SHEET,TECHNICAL:INSTR,A6303	80009	070-3906-01
	016-0622-01			1						CASE,CRYG,PROBE:W/INSERT	80009	016-0622-01

A6303 Current Probe

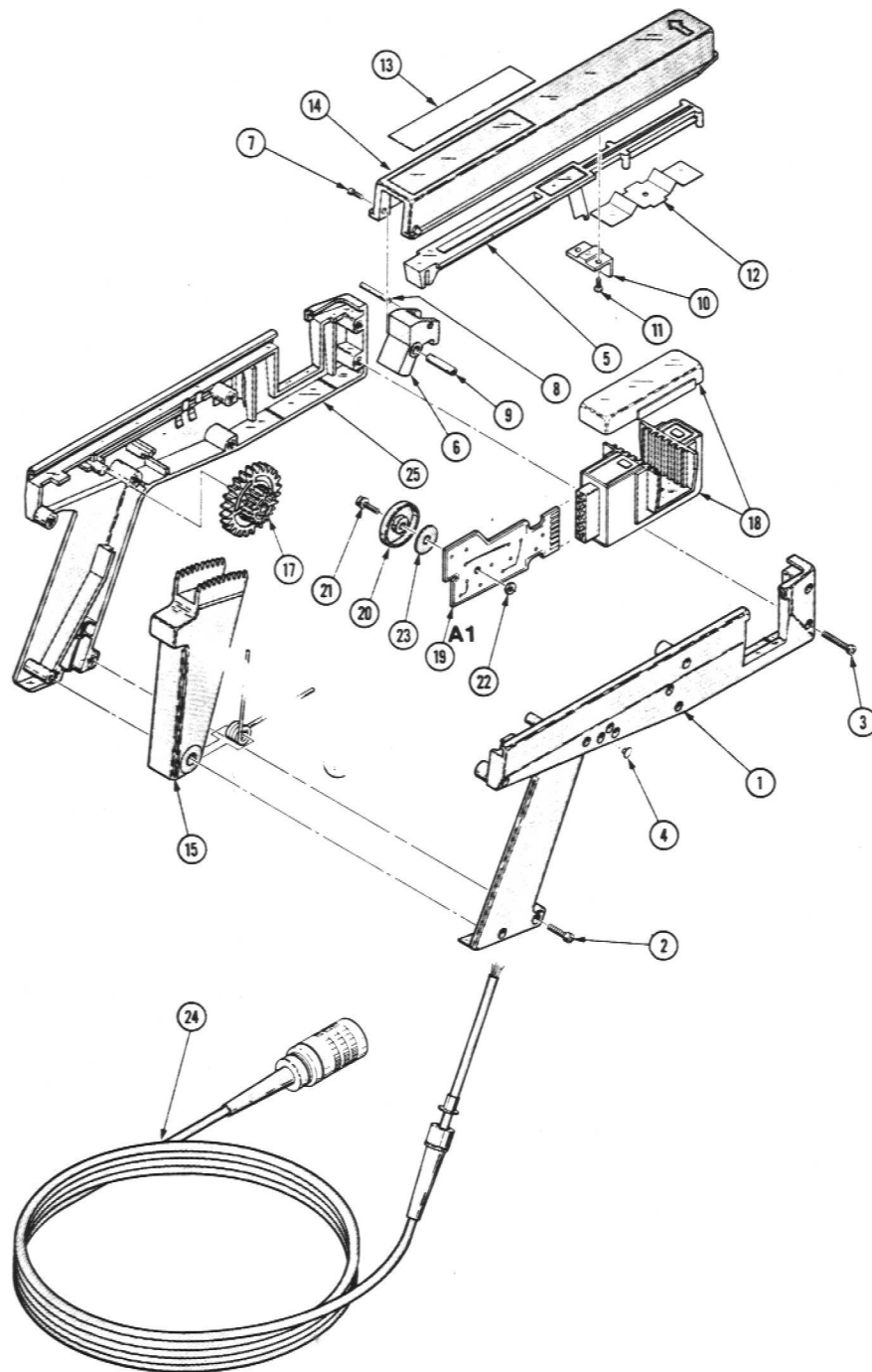

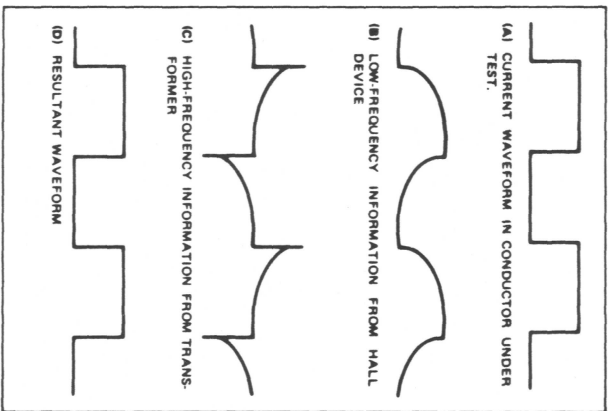
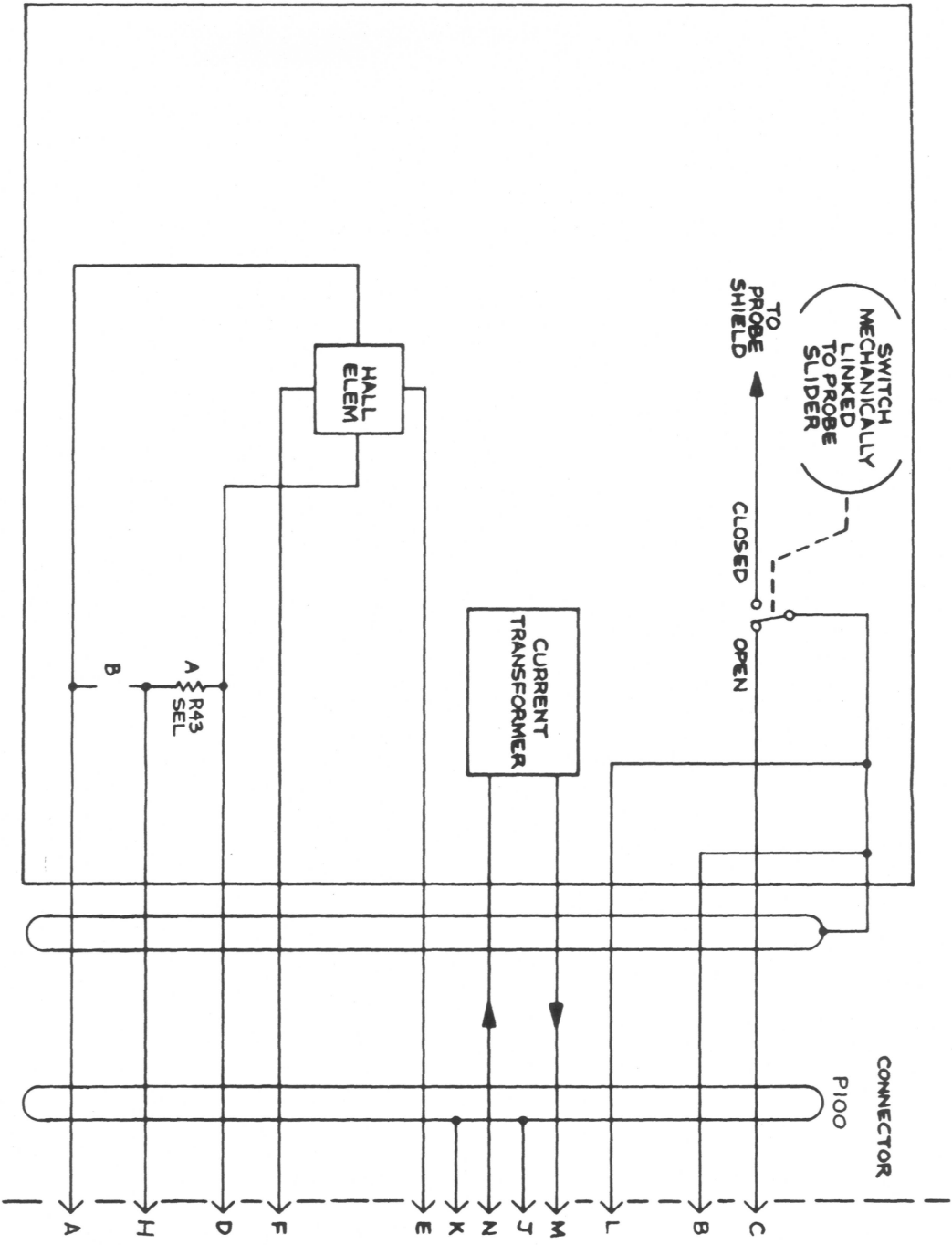

A6303

(2898-14) 3906-6
REV AUG 1981

BLOCK DIAGRAM

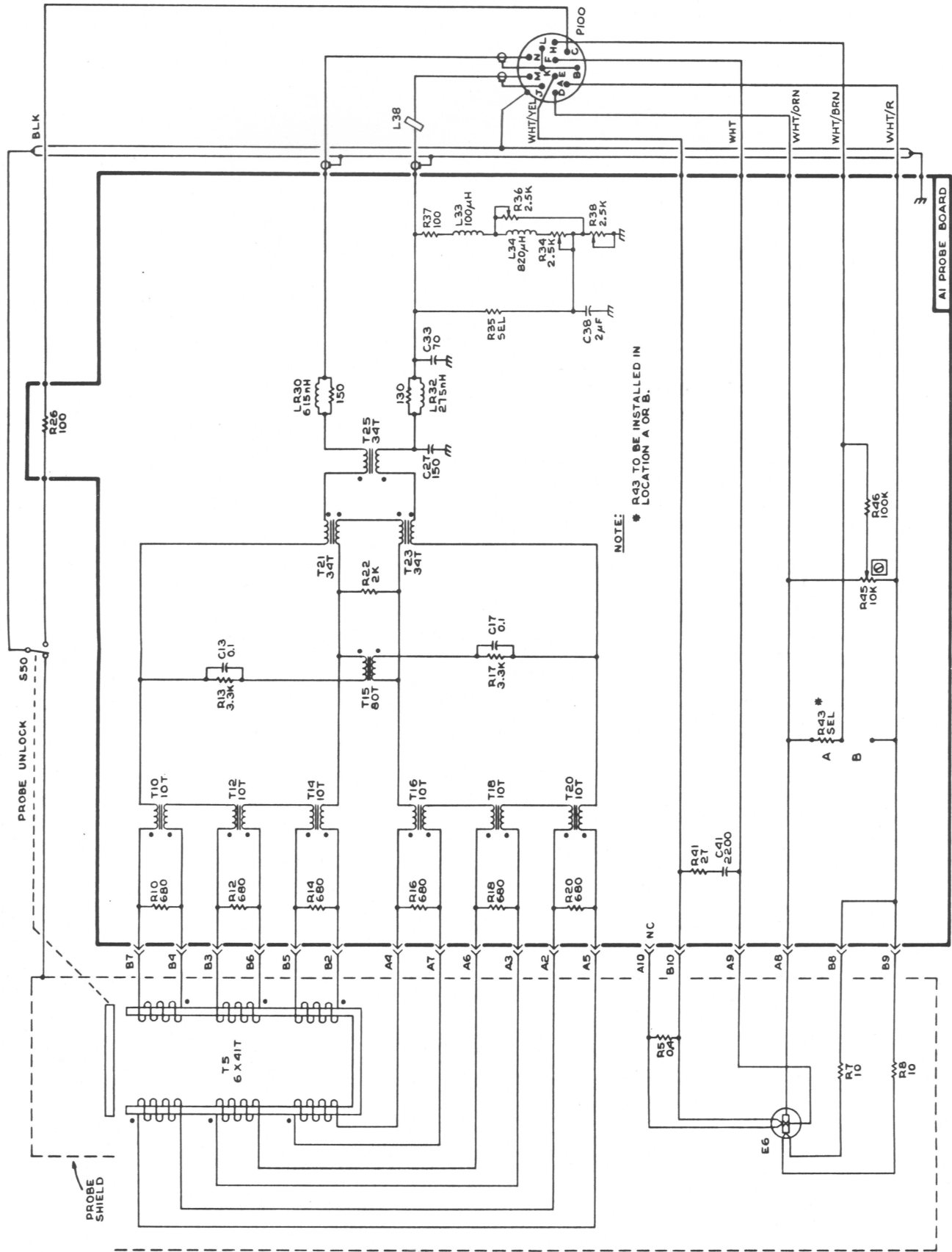

(2898-17)3906-7
REV AUG 1981

A6303 PROBE

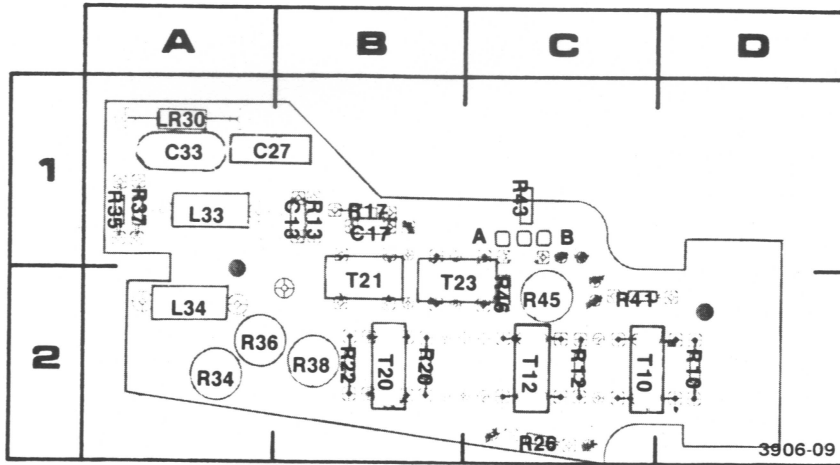

Location of parts on Probe board front.

CKT NO.	GRID LOC.	CKT NO.	GRID LOC.	CKT NO.	GRID LOC.
C13	B1	R12	C2	R43	C1
C17	B1	R13	B1	R45	C2
C27	A1	R17	B1	R46	C2
C33	A1	R20	B2	T10	C2
LR30	A1	R22	B2	T12	C2
L33	A1	R26	C2	T20	B2
L34	B1	R34	B1	T21	B2
R10	D2	R36	B1	T23	B2
		R37	A1		
		R38	B2		
		R41	C2		

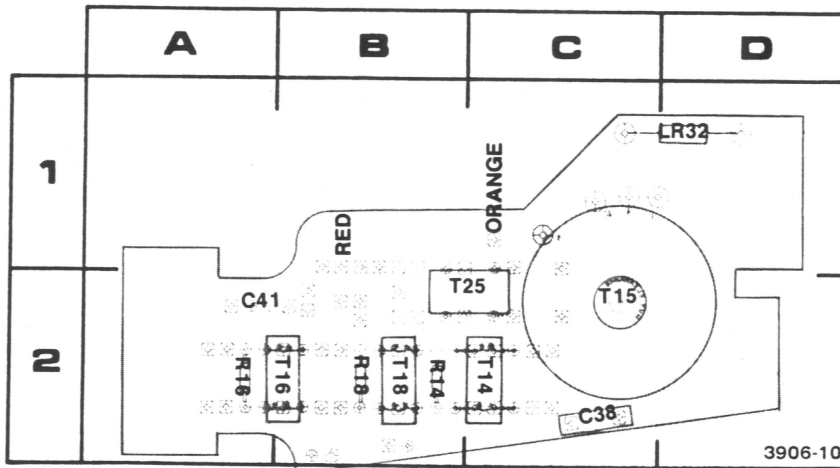

Location of parts on Probe board rear.

CKT NO.	GRID LOC.	CKT NO.	GRID LOC.
C38	C2	R18	B2
C41	A2	T14	C2
LR32	D1	T15	C2
R14	B2	T16	B2
R16	A2	T18	B2
		T25	C2