

Service Manual



TDS 420A, TDS 430A & TDS 460A Digitizing Oscilloscopes

070-9703-06

This document applies to instruments with serial numbers B050000 and above.

Warning

The servicing instructions are for use by qualified personnel only. To avoid personal injury, do not perform any servicing unless you are qualified to do so. Refer to all safety summaries prior to performing service.

www.tektronix.com

Copyright © Tektronix, Inc. All rights reserved.

Tektronix products are covered by U.S. and foreign patents, issued and pending. Information in this publication supercedes that in all previously published material. Specifications and price change privileges reserved.

Tektronix, Inc., P.O. Box 500, Beaverton, OR 97077

TEKTRONIX and TEK are registered trademarks of Tektronix, Inc.

WARRANTY

Tektronix warrants that the products that it manufactures and sells will be free from defects in materials and workmanship for a period of three (3) years from the date of shipment. If a product proves defective during this warranty period, Tektronix, at its option, either will repair the defective product without charge for parts and labor, or will provide a replacement in exchange for the defective product.

In order to obtain service under this warranty, Customer must notify Tektronix of the defect before the expiration of the warranty period and make suitable arrangements for the performance of service. Customer shall be responsible for packaging and shipping the defective product to the service center designated by Tektronix, with shipping charges prepaid. Tektronix shall pay for the return of the product to Customer if the shipment is to a location within the country in which the Tektronix service center is located. Customer shall be responsible for paying all shipping charges, duties, taxes, and any other charges for products returned to any other locations.

This warranty shall not apply to any defect, failure or damage caused by improper use or improper or inadequate maintenance and care. Tektronix shall not be obligated to furnish service under this warranty a) to repair damage resulting from attempts by personnel other than Tektronix representatives to install, repair or service the product; b) to repair damage resulting from improper use or connection to incompatible equipment; c) to repair any damage or malfunction caused by the use of non-Tektronix supplies; or d) to service a product that has been modified or integrated with other products when the effect of such modification or integration increases the time or difficulty of servicing the product.

THIS WARRANTY IS GIVEN BY TEKTRONIX IN LIEU OF ANY OTHER WARRANTIES, EXPRESS OR IMPLIED. TEKTRONIX AND ITS VENDORS DISCLAIM ANY IMPLIED WARRANTIES OF MERCHANTABILITY OR FITNESS FOR A PARTICULAR PURPOSE. TEKTRONIX' RESPONSIBILITY TO REPAIR OR REPLACE DEFECTIVE PRODUCTS IS THE SOLE AND EXCLUSIVE REMEDY PROVIDED TO THE CUSTOMER FOR BREACH OF THIS WARRANTY. TEKTRONIX AND ITS VENDORS WILL NOT BE LIABLE FOR ANY INDIRECT, SPECIAL, INCIDENTAL, OR CONSEQUENTIAL DAMAGES IRRESPECTIVE OF WHETHER TEKTRONIX OR THE VENDOR HAS ADVANCE NOTICE OF THE POSSIBILITY OF SUCH DAMAGES.

Contacting Tektronix

Phone	1-800-833-9200*
Address	Tektronix, Inc. Department or name (if known) 14200 SW Karl Braun Drive P.O. Box 500 Beaverton, OR 97077 USA
Web site	www.tektronix.com
Sales support	1-800-833-9200, select option 1*
Service support	1-800-833-9200, select option 2*
Technical support	Email: techsupport@tektronix.com 1-800-833-9200, select option 3* 1-503-627-2400 6:00 a.m. - 5:00 p.m. Pacific time

* **This phone number is toll free in North America. After office hours, please leave a voice mail message. Outside North America, contact a Tektronix sales office or distributor; see the Tektronix web site for a list of offices.**

Table of Contents

List of Figures	iii
List of Tables	vi
General Safety Summary	ix
Service Safety Summary	xi
Preface	xiii
Introduction	xvi
Before Servicing	xvi
Strategy for Servicing	xvi
Tektronix Service	xvii

Specifications

Product Description	1-1
Nominal Traits	1-7
Warranted Characteristics	1-15
Typical Characteristics	1-23

Operating Information

Installation	2-1
Supplying Operating Power	2-1
Operating Environment	2-3
Applying and Interrupting Power	2-4
Repackaging Instructions	2-5
Installed Options	2-5
Operating Information	2-7
Screen Layout	2-7
Basic Procedures	2-7

Theory of Operation

Theory of Operation	3-1
Logic Conventions	3-1
Module Overview	3-1

Performance Verification

Performance Verification Procedures	4-1
Brief Procedures	4-5
Self Tests	4-5
Functional Tests	4-7
Performance Tests	4-15
Prerequisites	4-15
Equipment Required	4-16
Test Record	4-18

Signal Acquisition System Checks	4-20
Time Base System Checks	4-34
Trigger System Checks	4-38
Output Signal Check	4-53
Sine Wave Generator Leveling Procedure	4-55

Adjustment Procedures

Adjustment Procedures	5-1
Requirements for Performance	5-1
Usage	5-2
Equipment Required	5-5
Adjustment Instructions	5-7
Probe Adjustment	5-10
Monitor Assembly Adjustment	5-21

Maintenance

Maintenance	6-1
Related Maintenance Procedures	6-1
Preparation	6-2
Inspection and Cleaning	6-4
Removal and Installation Procedures	6-9
Preparation — Please Read	6-9
Access Procedure	6-13
Procedures for Module Removal and Installation	6-23
Disassembly for Cleaning	6-71
Troubleshooting	6-75
Diagnostics	6-75
Firmware Updates	6-76
Troubleshooting Equipment	6-77

Options

Electrical Parts List

Diagrams

Mechanical Parts List

List of Figures

Figure 1-1: TDS 400A Dimensional Drawing	1-13
Figure 2-1: Map of Display Functions	2-8
Figure 4-1: Map of Display Functions	4-3
Figure 4-2: Verifying Adjustments and Signal Path Compensation	4-6
Figure 4-3: Universal Test Hookup for Functional Tests	4-8
Figure 4-4: Initial Test Hookup	4-20
Figure 4-5: Initial Test Hookup	4-23
Figure 4-6: Initial Test Hookup	4-26
Figure 4-7: Measurement of Analog Bandwidth	4-29
Figure 4-8: Initial Test Hookup	4-31
Figure 4-9: Measurement of Channel Delay	4-33
Figure 4-10: Initial Test Hookup	4-34
Figure 4-11: Measurement of Accuracy — Long-Term and Delay-Time	4-37
Figure 4-12: Initial Test Hookup	4-38
Figure 4-13: Initial Test Hookup	4-41
Figure 4-14: Measurement of Trigger Sensitivity	4-43
Figure 4-15: Initial Test Hookup	4-45
Figure 4-16: Confirming Auxiliary Triggering at Maximum Triggering Frequency	4-46
Figure 4-18: Initial Test Hookup	4-49
Figure 4-19: Adjusting Sync Pulse Amplitude	4-51
Figure 4-20: Measurement of Video Sensitivity	4-52
Figure 4-21: Initial Test Hookup	4-54
Figure 4-22: Measurement of Probe Compensator Limits	4-55
Figure 4-23: Sine Wave Generator Leveling Equipment Setup	4-56
Figure 4-24: Equipment Setup for maximum Amplitude	4-57
Figure 5-1: Hookup for Probe Compensation	5-10
Figure 5-2: Performing Probe Compensation	5-11
Figure 5-3: Proper and Improper Probe Compensation	5-12
Figure 5-4: Exposing the Inner Probe Tip	5-13
Figure 5-5: Initial Test Hookup	5-13
Figure 5-6: Exposing the Probe Body	5-16

Figure 5-7: Initial Test Hookup	5-16
Figure 5-8: Probe Test Hookup	5-18
Figure 5-9: Locations of Probe Adjustments	5-19
Figure 5-10: Adjustments vs. Front-Corner Response	5-20
Figure 5-11: Monitor Adjustment Locations	5-23
Figure 5-12: Five and Ten Percent Luminance Patches	5-24
Figure 5-13: Composite Pattern for Focusing	5-25
Figure 6-1: Oscilloscope Orientation	6-11
Figure 6-2: Cabinet and Front-Panel Mounted Modules	6-16
Figure 6-3: Internal Modules	6-19
Figure 6-4: Cables and cable routing, B010100 - B079999	6-22
Figure 6-5: Cables and cable routing, B080000 & up	6-23
Figure 6-6: Knob and shaft removal	6-25
Figure 6-7: Line fuse and line cord removal	6-26
Figure 6-8: Front cover, rear cover, cabinet, emi gasket, and cabinet handle and feet removal	6-28
Figure 6-9: Trim ring, menu elastomer, and menu buttons removal	6-31
Figure 6-10: EMI gasket removal and installation	6-33
Figure 6-11: Disk drive removal	6-34
Figure 6-12: A06 Front-Panel assembly, ESD shield, and menu flex and probe code flex circuits removal	6-36
Figure 6-13: Disassembly of the front-panel assembly	6-37
Figure 6-14: A05 Attenuator removal	6-40
Figure 6-15: A26 Monitor assembly removal	6-43
Figure 6-16: A08 Jumper board assembly, D1 Bus, and board supports removal	6-44
Figure 6-17: A03 CPU removal	6-46
Figure 6-18: A02 Display assembly removal	6-48
Figure 6-19: A09 DSP assembly removal	6-49
Figure 6-20: A01 Backplane assembly and its mount removal	6-51
Figure 6-21: Battery removal	6-54
Figure 6-22: Power factor correction module removal, B080000 & up	6-56
Figure 6-23: A24 Low voltage power supply removal, B080000 & up	6-59
Figure 6-24: A25 Low voltage power supply removal, B010100 - B079999	6-61
Figure 6-25: Fan and fan mount removal	6-64

Figure 6-26: Line filter removal	6-65
Figure 6-27: Auxiliary power supply removal, B010100 - B079999	6-68
Figure 6-28: A04 Acquisition Board Removal	6-70
Figure 6-29: Accessing the protection switch	6-76
Figure 6-30: Console port connections	6-79
Figure 6-31: Primary Troubleshooting Procedure	6-80
Figure 6-32: A03 CPU Board Connector P1	6-81
Figure 6-33: Module Isolation Troubleshooting Procedure	6-82
Figure 6-34: Low Voltage Power Supply Troubleshooting Procedure	6-84
Figure 6-35: Power Supply Overload Troubleshooting Procedure	6-86
Figure 6-36: A25 Low Voltage Power Supply Module (Right Side)	6-87
Figure 6-37: Monitor Troubleshooting Procedure	6-88
Figure 6-38: Horizontal and Vertical Sync Signals	6-89
Figure 6-39: A Video Signal with White, Black, and Blanking Levels	6-89
Figure 6-40: A26 Monitor Connector J440	6-90
Figure 6-41: A07 Auxiliary Power Connectors J4 and J7	6-90
Figure 6-42: A02 Display Connector J2	6-91
Figure 6-43: Processor/Front Panel Troubleshooting Procedure ...	6-92
Figure 6-44: A06 Front Panel Board Power Connectors J101 and J106	6-93
Figure 6-45: Attenuator/Acquisition Troubleshooting Procedure ..	6-94
Figure 6-46: A08 Jumper and A05 Attenuator Boards Signal Locations	6-95
Figure 6-47: Acquisition and Attenuator Power Troubleshooting Procedure	6-96
Figure 6-48: A04 Acquisition Board Power Connector	6-97
Figure 6-49: Backplane Troubleshooting Procedure	6-98
Figure 6-50: A01 Backplane Module	6-100
Figure 6-51: I2C Isolation Troubleshooting Procedure	6-101
Figure 6-52: Console Troubleshooting Procedure	6-102
Figure 9-1: TDS 400A Interconnections, B010100 - B079999	9-2
Figure 9-2: TDS 400A Interconnections, B010100 - B079999 (Cont)	9-3
Figure 9-3: TDS 400A Block Diagram, B010100 - B079999	9-4
Figure 9-4: TDS 400A Block Diagram, B010100 - B079999 (Cont)	9-5

Figure 9-5: TDS 400A Interconnections, B080000 & up	9-6
Figure 9-5: TDS 400A Interconnections, B080000 & up (Cont.) ...	9-7
Figure 9-6: TDS 400A Block Diagram, B080000 & up	9-8
Figure 9-6: TDS 400A Block Diagram, B080000 & up (Cont.)	9-9
Figure 10-1: External and front panel modules	10-7
Figure 10-2: Internal modules (B010100 - B079999)	10-9
Figure 10-3: Internal modules (B080000 - Up)	10-11
Figure 10-4: Cables and routing (B010100 - B079999)	10-13
Figure 10-5: Cables and routing (B080000 - Up)	10-15

List of Tables

Table 1-1: Key Features of the TDS 400A Oscilloscopes	1-1
Table 1-2: Record Length vs. Divisions per Record	1-3
Table 1-3: Nominal Traits — Signal Acquisition System	1-7
Table 1-4: Nominal Traits — Time Base System	1-9
Table 1-5: Nominal Traits — Triggering System	1-9
Table 1-6: Nominal Traits — Display System	1-10
Table 1-7: Nominal Traits — Data Storage	1-10
Table 1-8: Nominal Traits — GPIB Interface, Video Output, and Power Fuse	1-10
Table 1-9: Nominal Traits — Mechanical	1-11
Table 1-10: Warranted Characteristics — Signal Acquisition System	1-15
Table 1-11: Warranted Characteristics — Time Base System	1-17
Table 1-12: Warranted Characteristics — Triggering System	1-18
Table 1-13: Warranted Characteristics — Probe Compensator Output	1-18
Table 1-14: Warranted Characteristics — Power Requirements ..	1-18
Table 1-15: Warranted Characteristics — Environmental, Safety, and Reliability	1-19
Table 1-16: Certifications and compliances	1-20
Table 1-17: Typical Characteristics — Signal Acquisition System .	1-23
Table 1-18: Typical Characteristics — Time Base System	1-24
Table 1-19: Typical Characteristics — Triggering System	1-25
Table 1-20: Typical Characteristics — Data Handling	1-26
Table 2-1: Power-Cord Conductor Identification	2-2
Table 2-2: Power Cord Identification	2-2
Table 2-3: Effects of Corrupted Data	2-4
Table 4-1: Test Equipment	4-16
Table 4-2: DC Offset Accuracy	4-22
Table 4-3: Analog Bandwidth (TDS 420A)	4-27
Table 4-4: Analog Bandwidth (TDS 430A and TDS 460A)	4-28
Table 5-1: Adjustments Required for Module Replaced	5-3
Table 5-2: Adjustments and Dependencies	5-4
Table 5-3: Test Equipment, Fixtures, and Supplies	5-5

Table 5-4: GPIB Board Configuration1	5-7
Table 6-1: Relative Susceptibility to Static-Discharge Damage	6-3
Table 6-2: External Inspection Check List	6-5
Table 6-3: Internal Inspection Check List	6-6
Table 6-4: Tools Required for Module Removal	6-12
Table 6-5: Access Instructions for Modules in Figure 6-2	6-15
Table 6-6: Access Instructions for Modules in Figure 6-3	6-17
Table 6-7: Access (and Removal) Instructions for Cables in Figure 6-4	6-20
Table 6-8: Troubleshooting Test Equipment, Fixtures, and Supplies	6-77
Table 6-9: Connections for a 9 to 25 Pin Null Modem Cable	6-78
Table 6-10: Diagnostic Failure Priority Lists	6-83
Table 6-11: Normal Output Voltage	6-85
Table 6-12: Power Supply Maximum Current	6-87
Table 6-13: Front Panel Connector Voltages	6-93
Table 6-14: Channel and P1 Signal Locations	6-95
Table 6-15: A05 Attenuator Board Power	6-96
Table 6-16: A04 Acquisition Board Power	6-97
Table 6-17: Regulator Voltages	6-99
Table 6-18: J7 Voltages	6-99
Table 6-19: J8 Front Panel Voltages	6-99
Table 7-1: International Power Cords	7-2
Table 7-2: Standard Accessories	7-2
Table 7-3: Optional Accessories	7-3
Table 7-4: Compatible Probes	7-3
Table 7-5: Accessory Software	7-5

General Safety Summary

Review the following safety precautions to avoid injury and prevent damage to this product or any products connected to it.

To avoid potential hazards, use this product only as specified.

Only qualified personnel should perform service procedures.

Injury Precautions

Use Proper Power Cord. To avoid fire hazard, use only the power cord specified for this product.

Avoid Electric Overload. To avoid electric shock or fire hazard, do not apply a voltage to a terminal that is outside the range specified for that terminal.

Avoid Electric Shock. To avoid injury or loss of life, do not connect or disconnect probes or test leads while they are connected to a voltage source.

Ground the Product. This product is grounded through the grounding conductor of the power cord. To avoid electric shock, the grounding conductor must be connected to earth ground. Before making connections to the input or output terminals of the product, ensure that the product is properly grounded.

Do Not Operate Without Covers. To avoid electric shock or fire hazard, do not operate this product with covers or panels removed.

Use Proper Fuse. To avoid fire hazard, use only the fuse type and rating specified for this product.

Do Not Operate in Wet/Damp Conditions. To avoid electric shock, do not operate this product in wet or damp conditions.

Do Not Operate in an Explosive Atmosphere. To avoid injury or fire hazard, do not operate this product in an explosive atmosphere.

Product Damage Precautions

Use Proper Power Source. Do not operate this product from a power source that applies more than the voltage specified.

Provide Proper Ventilation. To prevent product overheating, provide proper ventilation.

Do Not Operate With Suspected Failures. If you suspect there is damage to this product, have it inspected by qualified service personnel.

Symbols and Terms

Terms in this Manual. These terms may appear in this manual:



WARNING. *Warning statements identify conditions or practices that could result in injury or loss of life.*



CAUTION. *Caution statements identify conditions or practices that could result in damage to this product or other property.*

Terms on the Product. These terms may appear on the product:

DANGER indicates an injury hazard immediately accessible as you read the marking.

WARNING indicates an injury hazard not immediately accessible as you read the marking.

CAUTION indicates a hazard to property including the product.

Symbols on the Product. The following symbols may appear on the product:



DANGER
High Voltage



Protective Ground
(Earth) Terminal



ATTENTION
Refer to Manual

**Certifications and
Compliances**

Refer to the specifications section for a listing of certifications and compliances that apply to this product.

Service Safety Summary

Only qualified personnel should perform service procedures. Read this *Service Safety Summary* and the *General Safety Summary* before performing any service procedures.

Do Not Service Alone. Do not perform internal service or adjustments of this product unless another person capable of rendering first aid and resuscitation is present.

Disconnect Power. To avoid electric shock, disconnect the main power by means of the power cord or, if provided, the power switch.

Use Caution When Servicing the CRT. To avoid electric shock or injury, use extreme caution when handling the CRT. Only qualified personnel familiar with CRT servicing procedures and precautions should remove or install the CRT.

CRTs retain hazardous voltages for long periods of time after power is turned off. Before attempting any servicing, discharge the CRT by shorting the anode to chassis ground. When discharging the CRT, connect the discharge path to ground and then the anode. Rough handling may cause the CRT to implode. Do not nick or scratch the glass or subject it to undue pressure when removing or installing it. When handling the CRT, wear safety goggles and heavy gloves for protection.

Use Care When Servicing With Power On. Dangerous voltages or currents may exist in this product. Disconnect power, remove battery (if applicable), and disconnect test leads before removing protective panels, soldering, or replacing components.

To avoid electric shock, do not touch exposed connections.

X-Radiation. To avoid x-radiation exposure, do not modify or otherwise alter the high-voltage circuitry or the CRT enclosure. X-ray emissions generated within this product have been sufficiently shielded.

Preface

This service manual provides service information for the TDS 420A, TDS 430A, and TDS 460A Digitizing Oscilloscopes.

STOP. If servicing a TDS 430A, follow the procedures for the TDS 460A, but ignore all references to CH 3 and CH 4.

Manual Structure

This manual is divided into Chapters such as *Specifications* and *Theory of Operation*. Further, it is divided into subsections such as *Product Description* and *Removal and Installation Procedures*.

Sections containing procedures also contain introductions to those procedures. Be sure to read these introductions because they provide information needed to do the service correctly and efficiently. A brief description of each manual chapter follows:

- *Specifications* contains a product description of the digitizing oscilloscope and tables of the characteristics and descriptions that apply to it.
- *Operating Information* is this chapter. It includes a description of how this manual is structured as well as general information and operating instructions at the level needed to safely power on and service this oscilloscope. A statement of the service strategy that this manual supports and instructions for shipment of the digitizing oscilloscope are found in this chapter.
- *Theory of Operation* contains circuit descriptions that support general service and fault isolation.
- *Performance Verification* contains a collection of procedures for confirming that this digitizing oscilloscope functions properly and meets warranted limits.
- *Adjustment Procedures* contains a collection of procedures for adjusting this digitizing oscilloscope to meet warranted limits.
- *Maintenance* contains information and procedures for doing preventive and corrective maintenance of the digitizing oscilloscope. Instructions for cleaning, for module removal and installation, and for fault isolation to a module are found here.

- *Options* contains information on the factory-installed options that may be present in your oscilloscope.
- *Electrical Parts List* contains a statement referring you to the *Mechanical Parts List*, where both electrical and mechanical modules are listed. See below.
- *Diagrams* contains a block diagram and an interconnection diagram useful for isolating failed modules.
- *Mechanical Parts List* includes a table of all replaceable modules, their descriptions, and their Tektronix part numbers.

Manual Conventions

This manual uses certain conventions which you should become familiar with before doing service.

Modules Throughout this manual, any replaceable component, assembly, or part of this digitizing oscilloscope is referred to generically as a module. In general, a module is an assembly, like a circuit board, rather than a component, like a resistor or an integrated circuit. Sometimes a single component is a module; for example, the chassis of the oscilloscope is a module.

Safety Symbols and terms related to safety appear in the *General Safety Summary* and *Service Safety Summary* found at the beginning of this manual.

Symbols Besides the symbols related to safety, this manual uses the following symbols:

STOP. This “stop sign” labels information which you must read in order to correctly do service and to avoid incorrectly using or applying service procedures.

 The clock icon labels procedure steps which require a pause to wait for the oscilloscope to complete some operation before you can continue.

 Various icons such as the example icon at the left are used in procedures to help identify certain readouts and menu functions on screen.

Related Manuals

These other manuals are available for the TDS 430A, TDS 420A, and TDS 460A Digitizing Oscilloscopes:

- The *Reference* gives you a quick overview of how to operate your oscilloscope.
- The *User Manual* provides instructions on how to operate your oscilloscope.
- The *Programmer Manual* provides complete information on programming and remote control of the oscilloscope through the GPIB.

Introduction

This section contains general information critical to safe and effective servicing of this oscilloscope, the manual service strategy, and a description of repair and warranty services available from Tektronix.

Before Servicing

This manual is for servicing the TDS 420A, TDS 430A, & TDS 460A Digitizing Oscilloscopes. To prevent injury to yourself or damage to the oscilloscope, do the following before you attempt service:

- Be sure you are a qualified service person.
- Read the safety summaries found at the beginning of this manual.
- Read *Strategy for Servicing and Supplying Operating Power* in this subsection.

When using this manual for servicing, be sure to heed all warnings, cautions, and notes.

STOP. *If servicing a TDS 430A, follow the procedures for the TDS 420A, but ignore all references to CH 3 and CH 4.*

Strategy for Servicing

STOP. *Throughout this manual, any field-replaceable component, assembly, or part of this oscilloscope is referred to generically as a module.*

This manual contains all the information needed for periodic maintenance of your oscilloscope. (Examples of such information are procedures for checking performance and for readjustment.) Further, it contains all information for corrective maintenance down to the module level. This means that the procedures, diagrams, and other troubleshooting aids help isolate failures to a specific module, rather than to components of that module. Once a failure is isolated, replace the module with a fully tested module obtained from the factory.

All modules are listed in Chapter 10, *Mechanical Parts List*. To isolate a failure to a module, use the fault isolation procedures found in Chapter 6, *Maintenance*.

To remove and replace any failed module, follow the instructions in *Removal and Installation Procedures*, also found in Chapter 6.

Tektronix Service

Tektronix provides service to cover repair under warranty as well as other services that may provide a cost-effective answer to your service needs.

Whether providing warranty repair service or any of the other services listed below, Tektronix service technicians, trained on Tektronix products, are best equipped to service your digitizing oscilloscope. Tektronix technicians are apprised of the latest information on improvements to the product as well as the latest new options to the product.

Warranty Repair Service

Tektronix warrants this product for three years from date of purchase, excluding probes for which the warranty is one year. (The warranty appears on the back of the title page in this manual.) Tektronix technicians provide warranty service at most Tektronix service locations worldwide. Your Tektronix product catalog lists all service locations worldwide.

Repair or Calibration Service

The following services may be purchased to tailor repair and/or calibration of your digitizing oscilloscope to fit your requirements.

Option 95. With this option, Tektronix ships a test data report for the oscilloscope.

At-Depot Service. Tektronix offers several standard-priced adjustment (calibration) and repair services:

- A single repair or adjustment
- Calibrations using equipment and procedures that meet the traceability standards specific to the local area
- Annual maintenance agreements that provide for either calibration and repair or calibration only of the oscilloscope

Of these services, the annual maintenance agreement offers a particularly cost-effective approach to service for many owners of the TDS 400A Digitizing Oscilloscopes. You can purchase such agreements to span several years.

Self Service

Tektronix supports repair to the module level by providing *Module Exchange* and *Module Repair and Return*.

Module Exchange. This service reduces down time for repair by allowing you to exchange most modules for remanufactured ones. Tektronix ships you an updated and tested exchange module from the Beaverton, Oregon service center, typically within 24 hours. Each module comes with a 90-day service warranty.

For More Information. Contact your local Tektronix service center or sales engineer for more information on any of the repair or adjustment services just described.

Product Description

This Chapter begins with a general description of the traits of the TDS 400A Digitizing Oscilloscopes. Three sections follow, one for each of three classes of traits: *nominal traits*, *warranted characteristics*, and *typical characteristics*.

General

The TDS 400A Digitizing Oscilloscopes are portable, four-channel instruments suitable for use in a variety of test and measurement applications and systems. Table 1-1 lists key features.

Table 1-1: Key Features of the TDS 400A Oscilloscopes

Feature	Description
Digitizing rate, maximum	100 MS/s on each channel simultaneously
Analog bandwidth	TDS 460A: 400 MHz TDS 420A: 200 MHz TDS 430A: 400 MHz
Channels	TDS 460A: Four, each with 8-bit resolution TDS 420A: Four, each with 8-bit resolution TDS 430A: Two, each with 8-bit resolution
Record lengths, maximum	30,000 samples (120,000 with option 1M)
Acquisition modes	Sample, envelope, average, high-resolution, and peak-detect
Trigger modes	Edge With Option 05, video trigger modes include: NTSC, SECAM, PAL, and Custom
Display Modes	Infinite and variable persistence, roll, fit to screen, and dual waveform zoom
Storage	A 1.44 Mbyte, 3.5 inch, DOS 3.3-or-later floppy disk and NVRAM storage for saving waveforms, hardcopies, and setups
I/O	Full GPIB programmability Hardcopy output using GPIB and, with Option 13, RS-232 or Centronics ports
Math	Including: invert, add, subtract, multiply, and with Option 2F, integral, differential, and FFT
User interface	A graphical user interface, on-line help, and a logical front-panel layout

User Interface

This digitizing oscilloscope uses a combination of front-panel buttons, knobs, and on-screen menus to control its many functions. The front-panel controls are grouped according to function: vertical, horizontal, trigger, and special. Within each group, any function likely to get adjusted often, such as vertical positioning or the time base setting, is set directly by its own front-panel knob.

Menus Those functions for which control settings are usually changed less often, such as vertical coupling and horizontal mode, are set indirectly. That is, pressing one (sometimes two) front-panel button, such as VERTICAL, displays a menu of functions at the bottom of the screen that are related to that button. (For the VERTICAL button, the menu displayed contains functions such as coupling and bandwidth.) Using the buttons below this *main* menu to select a function, such as coupling, displays a *side* menu of settings for that function, such as AC, DC, or GND (ground) coupling, at the right side of the screen. Use the buttons to the right of the menu to select a setting, such as DC.

Indicators Several on-screen readouts help you keep track of the settings for various functions, such as vertical and horizontal scale and trigger level. There are also readouts to display the results of measurements made using cursors or using the automatic parameter extraction feature (called measure) and readouts to display the status of the oscilloscope.

General Purpose Knob Menus are also used to assign the general purpose knob to adjust a selected parameter function. The method employed is the same as for *selecting* a function, except the final selection in the side menu causes the general purpose knob to *adjust* some function, such as the position of measurement cursors on screen or the setting for the fine gain of a channel.

GUI The user interface also makes use of a GUI, or Graphical User Interface, to make setting functions and interpreting the display more intuitive. Some menus and status are displayed using iconic representations of function settings such as those shown here for full, 100 MHz, and 20 MHz bandwidth. Such icons allow you to more readily determine status or the available settings.

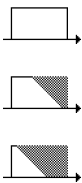

Signal Acquisition System

The signal acquisition system provides vertical channels with calibrated vertical scale factors from 1 mV to 10 V per division. All input channels can be acquired simultaneously.

You can display, vertically position, and offset each input channel. You can also limit their bandwidth (to either 100 MHz or 20 MHz), specify their vertical coupling, and adjust their fine gain.

Besides the input channels, up to three math waveforms and four reference waveforms are available for display. (A math waveform results when you specify operations such as add or invert; a reference waveform results when you save a live waveform in a reference memory.)

Horizontal System

There are three horizontal display modes: main only, main intensified, and delayed only. You can select among various horizontal record length settings (see Table 1-2).

Table 1-2: Record Length vs. Divisions per Record

Record Length ^{1, 2}	Divisions per Record (50 Points/Division)
120,000	2400 divs
60,000	1200 divs
30,000	600 divs
15,000	300 divs
5,000	100 divs
2,500	50 divs
1,000	20 divs
500	10 divs

¹ The 60,000 and 120,000 point record lengths are available only with Option 1M.

² If you select the Hi Res acquisition mode, the maximum Option 1M record length reduces to 60,000 points.

Both the delayed only display and the intensified zone on the main intensified display can be delayed by time with respect to the main trigger. You can set both to display immediately after the delay (delayed runs after main mode); you can set the delayed display to display at the first valid trigger after the delay (delayed triggerable mode).

The delayed display (or the intensified zone) can also be delayed by a selected number of events. In such a case, the events source is the delayed trigger source. For any events signal, the delayed-trigger system conditions the signal by determining the source, coupling, and other things, of that signal.

At time base settings of 20 ms per division or slower the records are displayable using Roll mode. Both untriggered roll and triggered roll modes are available.

Trigger System

The triggering system comprises a complete set of features for triggering the signal-acquisition system. In edge trigger mode, you can select the source, slope, coupling, mode (auto or normal), and holdoff.

Oscilloscopes ordered with Option 5 also have the video trigger mode. This trigger mode allows triggering on NTSC-standard, PAL-standard, SECAM-standard, and custom video waveforms. You can configure the triggering for interlaced or non-interlaced scanning, different scan rates, field selection, line selection, and for delay by line or time.

You can choose where the trigger point is located within the acquired waveform record by selecting the amount of pretrigger data displayed. You can select presets of 10%, 50%, and 90% of pretrigger data in the horizontal menu, or you can assign the General Purpose knob to set pretrigger data to any value within the limits of trigger position resolution.

Acquisition Control

Depending on your measurement requirements, you can specify the mode and manner in which signals are acquired and processed:

- You can select equivalent-time sampling on repetitive signals or interpolation of points sampled on non-repetitive signals. Both can increase the apparent sample rate on the waveform when maximum real-time rates are reached.
- You can use peak-detect, high-resolution, sample, envelope, and average modes to acquire signals.
- You can set the acquisition to stop after a single acquisition (or sequence of acquisitions if acquiring in average or envelope modes).

On-Board User Assistance

Two features that help you set up this digitizing oscilloscope to make your measurements are help and autose.

Help Help displays operational information about any front-panel control. When help mode is in effect, manipulating any front-panel control causes the digitizing oscilloscope to display information about that control. When help is first invoked, an introduction to help is displayed on screen.

Autose Autose automatically sets up the digitizing oscilloscope for a viewable display based on the input signal.

Measurement Assistance

Once you have set up to make your measurements, the features cursor and measure can help you quickly make those measurements.

Cursor Two types of cursors are provided for making parametric measurements on the displayed waveforms. Voltage can be measured between the positions of H Bar (horizontal) cursors, and time can be measured between V Bar (vertical) cursors. These are delta measurements; that is, measurements based on the difference between two cursors.

You can use both V Bar and H Bar cursors to make absolute measurements—measurements relative to a defined level or event. In the case of the H Bars, either cursor can be selected to read out its voltage with respect to the ground reference level of any channel; in the case of the V Bars, its time with respect to the trigger point (event) of the acquisition.

For time measurements, units can be either base (seconds or clocks) or inverse base (Hertz or 1/clocks).

Measure Measure can automatically extract parameters from the signal input to the digitizing oscilloscope. Any four out of the more than 20 parameters available can be displayed on the screen. The displayed parameters are extracted continuously and the results updated on screen as the digitizing oscilloscope continues to acquire waveforms.

Storage

TDS 400A Digitizing Oscilloscopes can save acquired waveforms in any of four nonvolatile REF (reference) memories. You can save any input-channel waveform to any REF memory, or you can move a stored reference from one REF memory to another. You can display any or all of the saved waveforms for comparison with the waveforms being currently acquired.

I/O

TDS 400A Digitizing Oscilloscopes are fully controllable and capable of sending and receiving waveforms over the GPIB interface (IEEE Std 488.1-1987/IEEE Std 488.2-1987 standard). Self-compensation and self-diagnostic features built into the digitizing oscilloscope to aid in fault detection and servicing are also accessible using commands sent from a GPIB controller. The oscilloscope also provides the following output capabilities:

- Output of the current oscilloscope screen, including waveforms, to a variety of graphic printers and plotters to obtain hard copies. You can start a hardcopy from the oscilloscope front panel; you are not required to connect into a system-controller environment. The hard copies obtained are WYSIWYG (What-You-See-Is-What-You-Get), based on what is displayed at the time hardcopy is invoked.
- Output of display hard copies, of oscilloscope control setups, and of waveforms to a floppy disk in the oscilloscope file system.
- Output of the oscilloscope display for monitoring (or other processing) from a VGA-compatible video output on the oscilloscope rear panel.

Display

The TDS 400A Digitizing Oscilloscopes offer flexible display options. You can customize the following attributes of your display:

- Intensity: waveforms, readouts, graticule, and other things
- Style of waveform display(s): vectors or dots, intensified or non-intensified samples, and infinite or variable persistence
- Display format: XY or YT and graticule type

This digitizing oscilloscope also provides an easy way to focus in on those waveform features you wish to examine up close. By using ZOOM, you can magnify the waveform parameter using the vertical and horizontal controls to expand (or contract) and position it for viewing.

Nominal Traits

Nominal traits are described using simple statements of fact such as “Four, all identical” for the trait “Input Channels, Number of,” rather than in terms of limits that are performance requirements.

Table 1-3: Nominal Traits — Signal Acquisition System

Name	Description	
Bandwidth Selections	20 MHz, 100 MHz, and FULL (TDS 420A: 200 MHz, TDS 430A and TDS 460A: 400 MHz)	
Digitizers, Number of	TDS 430A: Two, both identical TDS 420A and TDS 460A: Four, all identical	
Digitized Bits, Number of	8 bits ¹	
Digitized Resolution, Hi Res Mode	Clock, Internal: $\text{Resolution}_{\text{HiRes}} \cong 8 \leq \left[8 + 0.5 \text{Log}_2 \left(\frac{\text{time/div}}{500 \cdot 10^{-9}} \right) \right] \leq 15 \text{ bits}$ Clock, External: $\text{Resolution}_{\text{HiRes}} \cong 8 \leq \left[8 + 0.5 \text{Log}_2 \left(\frac{100,000,000}{\text{ClockExternalMenu}} \right) \right] \leq 11.8 \text{ bits}$	
Bandwidth, Hi Res Mode	Clock, Internal: For $1\mu\text{s/div}$ and slower, $\text{BW}_{\text{HiRes}} \cong 0.44 \cdot \left(\frac{50}{\text{time/div}} \right) \text{ Hz}$ Clock, External: $\text{BW}_{\text{HiRes}} \cong 44 \cdot \left(\frac{\text{ClockExternalMenu}}{100} \right) \text{ Hz}$	
Input Channels, Number of	TDS 430A: Two, both identical, called CH 1 and CH 2 TDS 420A and TDS 460A: Four, all identical, called CH 1 through CH 4	
Input Coupling	DC, AC, or GND ²	
Input Resistance Selections	1 MΩ or 50 Ω	
Ranges, Offset, All Channels	Volts/Div Setting	Offset Range
	1 mV/div to 99.5 mV/div	±1 V
	100 mV/div to 995 mV/div	±10 V
	1 V/div to 10 V/div	±100 V
Range, Position	±5 divisions	
Range, Sensitivity ³	1 mV/div to 10 V/div	

Table 1-3: Nominal Traits — Signal Acquisition System (Cont.)

Name	Description	
Rise Time ⁴ (TDS420A)	Volts/Div Setting	Rise Time
	5 mV/div-10 V/div	1.75 ns
	2 mV/div-4.98 mV/div	2.33 ns
	1 mV/div-1.99 mV/div	3.68 ns
Rise Time ⁴ (TDS 430A and TDS 460A)	Volts/Div Setting	Rise Time
	5 mV/div-10 V/div	875 ps
	2 mV/div-4.98 mV/div	1.4 ns
	1 mV/div-1.99 mV/div	3.5 ns

- ¹ Displayed vertically with 25 digitization levels (DLs) per division and 10.24 divisions dynamic range with zoom off. A DL is the smallest voltage level change resolved by the 8-bit A-D Converter with the input scaled to the volts/division setting of the channel used. Expressed as a voltage, a DL is equal to 1/25 of a division times the volts/division setting.
- ² GND input coupling disconnects the input connector from the attenuator and connects a ground reference to the input of the attenuator.
- ³ The sensitivity ranges from 1 mV/div to 10 V/div in a 1-2-5 sequence of coarse settings. Between consecutive coarse settings, the sensitivity can be finely adjusted with a resolution of 1% of the more sensitive setting. For example, between 50 mV/div and 100 mV/div, the volts/division can be set with 0.5 mV resolution.
- ⁴ Rise time is defined by the following formula:
$$Rise\ Time\ (ns) = \frac{420}{BW\ (MHz)}$$

Table 1-4: Nominal Traits — Time Base System

Name	Description
Range, Sample-Rate ^{1,3}	2.5 Samples/s to 100 MSamples/s
Range, Equivalent Time or Interpolated Waveform Rate ^{2,3}	200 MSamples/s to 50 GSamples/s
Range, Seconds/Division	1 ns/div to 20 s/div
Range, Time Base Delay Time	0 to 20 seconds
Reference Frequency, Time Base	100 MHz
Record Length Selection	500, 1,000, 2,500, 5,000, 15,000, and 30,000 points. Record lengths of 60,000 and 120,000 points are available with Option 1M ⁴
Sampling Edge, External Clock	Negative edge, with TTL threshold and tolerances
Hi Res Averaging Period, External Clock	Hi Res averaging done over period 1/(maximum external clock rate ⁵), but within <100 ns to 2 μ s. An external clock edge before this period ends produces an invalid sample.

- ¹ **The range of real-time rates, expressed in samples/second, at which a digitizer samples signals at its inputs and stores the samples in memory to produce a record of time-sequential samples.**
- ² **The range of waveform rates for equivalent time or interpolated waveform records.**
- ³ **The Waveform Rate (WR) is the equivalent sample rate of a waveform record. For a waveform record acquired by real-time sampling of a single acquisition, the waveform rate is the same as the real-time sample rate; for a waveform created by interpolation of real-time samples from a single acquisition or by equivalent-time sampling of multiple acquisitions, the waveform rate is faster than the real time sample rate. For all three cases, the waveform rate is 1/(Waveform Interval) for the waveform record, where the waveform interval (WI) is the time between the samples in the waveform record.**
- ⁴ **In Hi Res, the maximum Option 1M record length is 60,000 points.**
- ⁵ **You set the maximum external clock rate using the Horizontal Clock menu. The Hi Res samples are averaged over a 10 to 40 ns shorter period than shown by the readout.**

Table 1-5: Nominal Traits — Triggering System

Name	Description	
Range, Events Delay	1 to 9,999,999	
Ranges, Trigger Level or Threshold	Source	Range
	Any Channel	\pm 12 divisions from center of screen
	Line	\pm 400 Volts

Table 1-6: Nominal Traits — Display System

Name	Description
Video Display Resolution	640 pixels horizontally by 480 pixels vertically in a display area of 5.04 inches horizontally by 3.78 inches vertically
Waveform Display Graticule	A single graticule 401 × 501 pixels (8 × 10 divisions, with divisions that are 1 cm by 1 cm)
Waveform Display Grey Scale	16 levels in variable-persistence display style

Table 1-7: Nominal Traits — Data Storage

Name	Description
Capacity, Nonvolatile Waveform Memory	Total capacity is 120,000 points (one to four waveforms acquired with any combination of record lengths that add up to 120,000 points). For available record lengths, see <i>Record Length Selection</i> on page 1-9 of this chapter.
Capacity, Nonvolatile Setup Memory	Ten setups
Batteries ¹ Required	Two lithium poly-carbon monofluoride. Both are type BR2/3A, UL listed. Both are rated at 3.0 volt, 1.2 amp-hour.

¹ **Batteries are not accessible from the outside of the instrument; therefore, a service technician must replace them.**

Table 1-8: Nominal Traits — GPIB Interface, Video Output, and Power Fuse

Name	Description
Interface, GPIB	GPIB interface complies with IEEE Std 488.1-1987 and IEEE Std 488.2-1987.
Interface, RS-232 (Option 13 only)	RS-232 interface complies with EIA/TIA 574.
Interface, Centronics (Option 13 only)	Centronics interface complies with Centronics interface standard C332-44 Feb 1977, REV A.
Power Supply, Printer (Option 13 only)	Supply Voltage: +6.5 VDC Maximum Current: 2 Amps, DC continuous 4 Amps DC maximum for durations < 10 msec
Output, Video	Provides a video signal ¹ , non-interlaced, with levels that comply with ANSI RS343A. Output is through a rear-panel DB-15 connector.
Fuse Rating	Either of two fuses ² may be used: a 0.25" × 1.25" (UL 198.6, 3AG): 8A FAST, 250 V, or a 5 mm × 20 mm, (IEC 127): 6.3 A FAST, 250 V.

¹ **VGA compatible at 30.6 kHz sync rate.**

² **Each fuse type requires its own fuse cap.**

Table 1-9: Nominal Traits — Mechanical

Name	Description
Cooling Method	Forced-air circulation with no air filter
Construction Material	Chassis parts constructed of aluminum alloy; front panel constructed of plastic laminate; circuit boards constructed of glass-laminate. Plastic parts are polycarbonate.
Finish Type	Tektronix Blue textured vinyl finish on aluminum cabinet
Weight	<p>Standard digitizing oscilloscope</p> <ul style="list-style-type: none"> 9.8 kg (21.6 lbs), oscilloscope only 11.4 kg (25.1 lbs), with front cover, accessories, and accessories pouch installed 15.7 kg (34.6 lbs), when packaged for domestic shipment 225 grams (0.5 lbs) Floppy Disk Drive only <p>Rackmount digitizing oscilloscope</p> <ul style="list-style-type: none"> 9.4 kg (20.6 lbs) plus the weight of rackmount parts, for the rackmounted digitizing oscilloscope (Option 1R) 17.5 kg (38.6 lbs), when the rackmounted digitizing oscilloscope is packaged for domestic shipment <p>Rackmount conversion kit</p> <ul style="list-style-type: none"> 4.5 kg (10.0 lbs), parts only; 7.9 kg (17.5 lbs), parts plus package for domestic shipping

Table 1-9: Nominal Traits — Mechanical (Cont.)

Name	Description
Overall Dimensions	<p>Standard digitizing oscilloscope</p> <p>Height 191 mm (7.5 in), when feet and accessories pouch are installed. 165 mm (6.5 in), without the accessories pouch installed</p> <p>Width 381 mm (15 in), with handle</p> <p>Depth 471 mm (18.55 in), oscilloscope only; 490 mm (19.28 in), with optional front cover installed; 569 mm (22.4 in), with handle fully extended</p> <p>Rackmount digitizing oscilloscope</p> <p>Height 178 mm (7.0 in)</p> <p>Width 483 mm (19.0 in)</p> <p>Depth 472 mm (18.6 in), without front-panel handles; 517 mm (20.35 in), with front-panel handles installed</p>

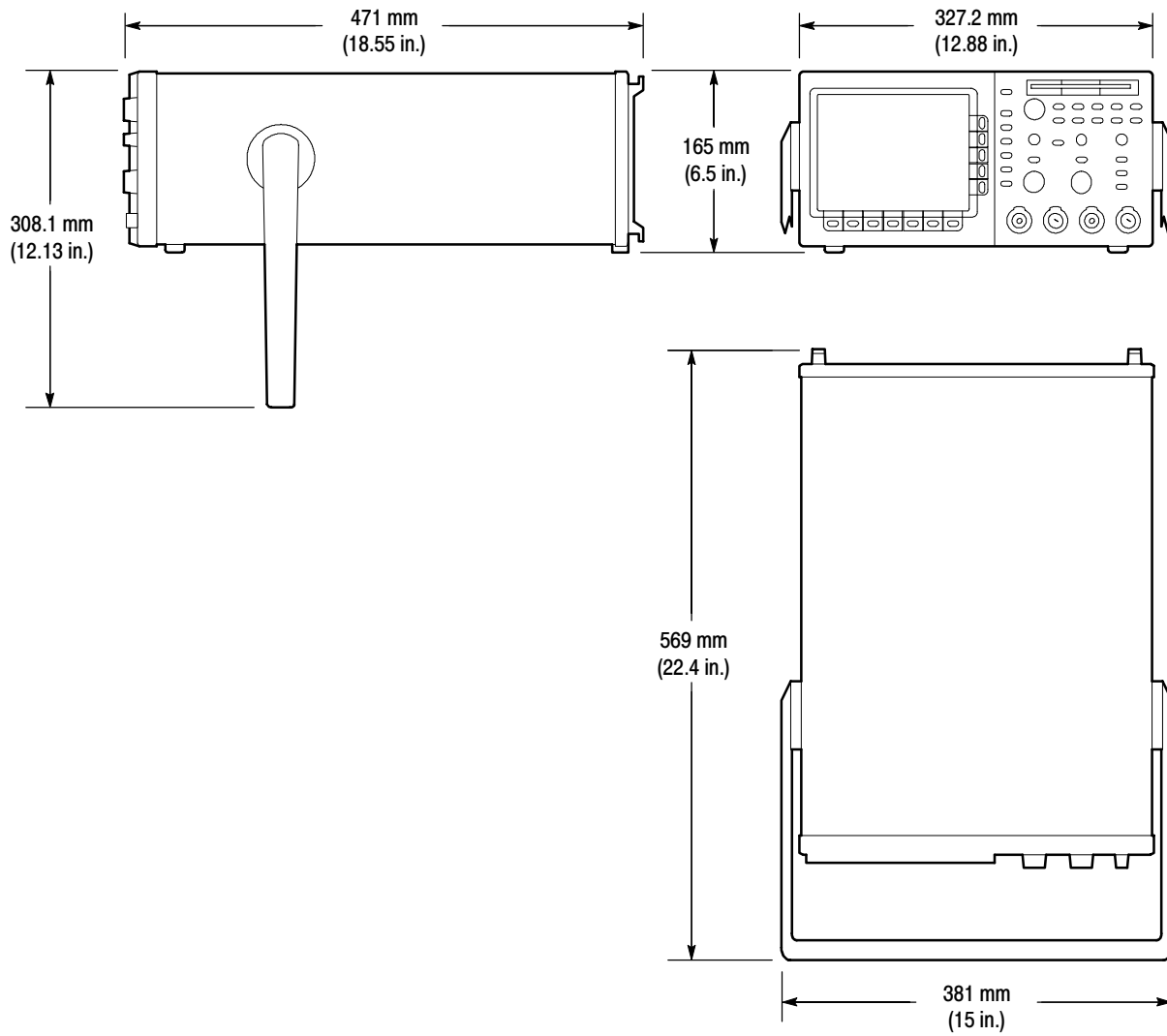

Figure 1-1: TDS 400A Dimensional Drawing

Warranted Characteristics

This section lists the various *warranted characteristics* that describe the TDS 400A Digitizing Oscilloscopes. Included are electrical and environmental characteristics.

Warranted characteristics are described in terms of quantifiable performance limits which are warranted. This section lists only warranted characteristics. A list of *typical characteristics* starts on page 1-23.

NOTE. In these tables, those warranted characteristics that are checked in the procedure Performance Tests, on page 4-15, appear in **boldface type** under the column **Name**.

Performance Conditions

The electrical characteristics found in these tables of warranted characteristics apply when the oscilloscope is adjusted at an ambient temperature between +20° C and +30° C, has had a warm-up period of at least 20 minutes, and is operating at an ambient temperature between 0° C and +50° C (unless otherwise noted).

Table 1-10: Warranted Characteristics — Signal Acquisition System

Name	Description	
Accuracy, DC Voltage Measurement, Averaged	Measurement Type	DC Accuracy
	Average of ≥ 16 waveforms	$\pm(1.5\% \times (\text{reading} - \text{Net Offset}^1) + \text{Offset Accuracy} + 0.06 \text{ div} \times \text{Vertical Scale})$
	Delta volts between any two averages of ≥ 16 waveforms ²	$\pm(1.5\% \times \text{reading} + 0.3 \text{ mV} + 0.1 \text{ div} \times \text{Vertical Scale})$
Accuracy, DC Gain³	$\pm 1.5\%$	
Accuracy, Offset	Volts/Div Setting	Offset Accuracy
	1 mV/div-9.95 mV/div	$\pm(0.4\% \times \text{Net Offset}^1 + (0.9 \text{ mV} + 0.1 \text{ div} \times \text{Vertical Scale}))$
	10 mV/div-99.5 mV/div	$\pm(0.4\% \times \text{Net Offset}^1 + (1.5 \text{ mV} + 0.1 \text{ div} \times \text{Vertical Scale}))$
	100 mV/div-995 mV/div	$\pm(0.4\% \times \text{Net Offset}^1 + (15 \text{ mV} + 0.1 \text{ div} \times \text{Vertical Scale}))$
	1 V/div-10 V/div	$\pm(0.4\% \times \text{Net Offset}^1 + (150 \text{ mV} + 0.1 \text{ div} \times \text{Vertical Scale}))$
Accuracy, Position⁴	$\pm(1.5\% \times (\text{Position} \times \text{Volts/div}) + \text{Offset Accuracy} + 0.04 \text{ div})$	

Table 1-10: Warranted Characteristics — Signal Acquisition System (Cont.)

Name	Description		
Analog Bandwidth, DC-50 Ω Coupled to BNC and Bandwidth Selection is Full	Volts/Div	TDS 420A Bandwidth⁵	TDS 430A and TDS 460A Bandwidth⁵
	5 mV/div-10 V/div	DC-200 MHz	DC-400 MHz
	2 mV/div-4.98 mV/div	DC-150 MHz	DC-250 MHz
	1 mV/div-1.99 mV/div	DC-95 MHz	DC-100 MHz
Cross Talk (Channel Isolation)	Volts/Div	Isolation	
	> 500 mV/div	$\geq 40:1$ at 50 MHz for any two channels having equal volts/division settings	
	≤ 9.95 mV/div	$\geq 40:1$ at 50 MHz for any two channels having equal volts/division settings	
	10 mV/div-500 mV/div	$\geq 80:1$ at 100 MHz and $\geq 30:1$ at full bandwidth for any two channels having equal volts/division settings	
Delay Between Channels, Full Bandwidth, Equivalent Time	≤ 200 ps between CH 1 and CH 2 and between CH 3 and CH 4 when both channels have equal volts/division and coupling settings		
	≤ 450 ps for any other combination of two channels with equal volts/division and coupling settings		
Input Impedance, DC-1 M Ω Coupled	1 M Ω $\pm 0.5\%$ in parallel with 15 pF ± 2.0 pF. Matched between channels to within $\pm 1\%$ for resistance and ± 1.0 pF for capacitance		
Input Impedance, DC-50 Ω Coupled (TDS 420A)	50 Ω $\pm 1\%$ with VSWR $\leq 1.2:1$ from DC-200 MHz		
Input Impedance, DC-50 Ω Coupled (TDS 430A and TDS 460A)	50 Ω $\pm 1\%$ with VSWR $\leq 1.6:1$ from DC-400 MHz		
Input Voltage, Maximum, DC-1 M Ω , AC-1 M Ω , or GND Coupled	Volt/Div	Rating	
	0.1 V/div-10 V/div	300 V CAT II; derate at 20 dB/decade above 10 MHz until the minimum rating of ± 5 V (DC + peak AC) is reached	
	1 mV/div-99.9 mV/div	300 V CAT II; derate at 20 dB/decade above 10 kHz until the minimum rating of ± 5 V (DC + peak AC) is reached	
Input Voltage, Maximum, DC-50 Ω or AC-50 Ω Coupled	5 V _{RMS} , with peaks less than or equal to ± 30 V		

Table 1- 10: Warranted Characteristics — Signal Acquisition System (Cont.)

Name	Description
Lower Frequency Limit, AC Coupled	≤ 10 Hz when AC-1 M Ω coupled; ≤ 200 kHz when AC-50 Ω coupled ⁶
¹	Net Offset = Offset - (Position \times Volts/Div). Net Offset is the voltage level at the center of the A-D converter dynamic range. Offset Accuracy is the accuracy of this voltage level.
²	The samples must be acquired under the same setup and ambient conditions.
³	DC Gain Accuracy is confirmed in the Performance Verification Procedure by passing the checks for Offset Accuracy and DC Voltage Measurement Accuracy (Averaged).
⁴	Position Accuracy is confirmed in the Performance Verification Procedure by passing the checks for Offset Accuracy and DC Voltage Measurement Accuracy (Averaged).
⁵	The limits given are for the ambient temperature range of 0° C to +30° C. Reduce the upper bandwidth frequencies by 2.5 MHz for each °C above +30° C.
⁶	The AC Coupled Lower Frequency Limits are reduced by a factor of 10 when 10X, passive probes are used.

Table 1- 11: Warranted Characteristics — Time Base System

Name	Description
Accuracy, Long Term Sample Rate and Delay Time	± 150 ppm over any ≥ 1 ms interval
Accuracy, Absolute Time and Delay Time Measurements ^{1,2}	For single-shot acquisitions using sample or high-resolution acquisition modes and a bandwidth limit setting of 100 MHz: $\pm (1 \text{ WI} + 150 \text{ ppm of } \text{Reading} + 450 \text{ ps})$ For single-shot acquisitions using sample or high-resolution acquisition modes and a bandwidth limit setting of 20 MHz: $\pm (1 \text{ WI} + 150 \text{ ppm of } \text{Reading} + 1.3 \text{ ns})$ For repetitive acquisitions using average acquisition mode with ≥ 8 averages and a bandwidth limit setting of FULL: $\pm (1 \text{ WI} + 150 \text{ ppm of } \text{Reading} + 200 \text{ ps})$
Accuracy, Delta Time Measurement^{1,2}	For single-shot acquisitions using sample or high-resolution acquisition modes and a bandwidth limit setting of 100 MHz: $\pm (1 \text{ WI} + 150 \text{ ppm of } \text{Reading} + 650 \text{ ps})$ For repetitive acquisitions using average acquisition mode with ≥ 8 averages and a bandwidth limit setting of FULL: $\pm (1 \text{ WI} + 150 \text{ ppm of } \text{Reading} + 300 \text{ ps})$

¹ **For input signals ≥ 5 divisions in amplitude and a slew rate of ≥ 2.0 divisions/ns at the delta time measurement points. Signal must have been acquired at a volts/division setting ≥ 5 mV/division and not in Events mode.**

² **The WI (waveform interval) is the time between the samples in the waveform record. Also, see the footnotes for Sample Rate Range and Equivalent Time or Interpolated Waveform Rates in Table 1-4 on page 1-9.**

Table 1-12: Warranted Characteristics — Triggering System

Name	Description
Accuracy, Trigger Level or Threshold, DC Coupled	$\pm(2\% \text{ of } \text{Setting} - \text{Net Offset}^1 + 0.2 \text{ div} \times \text{volts/div setting} + \text{Offset Accuracy})$ for any channel as trigger source and for signals having rise and fall times ≥ 20 ns
Sensitivity, Edge-Type Trigger, DC Coupled²	0.35 division from DC to 50 MHz, increasing to 1 division at 350 MHz (TDS 420A) or 500 MHz (TDS 430A and TDS 460A) for any channel as trigger source
Sensitivity, Video-Type, TV Field and TV Line²	0.6 division of video sync signal
Pulse Width, minimum, Events-Delay	5 ns
Auxiliary Trigger Input, External Clock Input	Connector: BNC at rear panel Input Load: equivalent to three TTL gate loads Input Voltage (maximum): -5 VDC to +10 VDC (TTL levels recommended)
Auxiliary Trigger, Maximum Input Frequency	10 MHz Duty Cycle High and low levels must be stable for ≥ 50 ns
Frequency, External Clock	DC to 10 MHz High and low levels must be stable for ≥ 50 ns

¹ **Net Offset = Offset - (Position × Volts/Div). Net Offset is the voltage level at the center of the A-D converter dynamic range. Offset Accuracy is the accuracy of this voltage level.**

² **The minimum sensitivity for obtaining a stable trigger. A stable trigger results in a uniform, regular display triggered on the selected slope. The trigger point must not switch between opposite slopes on the waveform, and the display must not “roll” across the screen on successive acquisitions. The TRIG'D LED stays constantly lighted when the SEC/DIV setting is 2 ms or faster but may flash when the SEC/DIV setting is 10 ms or slower.**

Table 1-13: Warranted Characteristics — Probe Compensator Output

Name	Description	
Output Voltage and Frequency, Probe Compensator	Characteristic	Limits
	Voltage	0.5 V (base-top) $\pm 5\%$ into a 1 M Ω load
	Frequency	1 kHz $\pm 5\%$

Table 1-14: Warranted Characteristics — Power Requirements

Name	Description
Source Voltage and Frequency	100 to 240 VAC $\pm 10\%$ CAT II, continuous range, for 50 Hz/60 Hz 115 VAC $\pm 10\%$ CAT II, continuous range, for 400 Hz
Power Consumption	≤ 250 Watts

Table 1- 15: Warranted Characteristics — Environmental, Safety, and Reliability

Name	Description
Atmospherics	<p>Temperature¹:</p> <p>Operating, +0° C to +50° C (disk drive operation limited to +4° C minimum); Nonoperating, -22° C to +60° C</p> <p>Relative humidity:</p> <p>Operating without disk, to 80%, at or below +29° C; to 20%, at or below +50° C; Operating with disk, 20% (+4° C to +50° C) to 80% (+4° C to +29° C) ; Nonoperating, 20% (+4° C to +60° C) to 90% (+22° C to +40° C)</p> <p>Altitude:</p> <p>Operating, to 15,000 ft. (4570 m); Nonoperating, to 40,000 ft. (12190 m)</p>

¹ Maximum operating temperature is decreased 1° C per 1000 feet (305 meters) above 5000 feet (1525 meters).

Table 1-16: Certifications and compliances

Category	Standards or description																
EC Declaration of Conformity - EMC ¹	<p>Meets intent of Directive 89/336/EEC for Electromagnetic Compatibility. Compliance was demonstrated to the following specifications as listed in the Official Journal of the European Communities:</p> <table> <tr> <td>EN 61326</td> <td>EMC requirements for Class A electrical equipment for measurement, control and laboratory use.²</td> </tr> <tr> <td>IEC 61000-4-2</td> <td>Electrostatic discharge immunity (Performance criterion B)</td> </tr> <tr> <td>IEC 61000-4-3</td> <td>RF electromagnetic field immunity³ (Performance criterion A)</td> </tr> <tr> <td>IEC 61000-4-4</td> <td>Electrical fast transient / burst immunity (Performance criterion B)</td> </tr> <tr> <td>IEC 61000-4-5</td> <td>Power line surge immunity (Performance criterion B)</td> </tr> <tr> <td>IEC 61000-4-6</td> <td>Conducted RF immunity (Performance criterion A)</td> </tr> <tr> <td>IEC 61000-4-11</td> <td>Voltage dips and interruptions immunity (Performance criterion B)</td> </tr> <tr> <td>EN 61000-3-2</td> <td>AC power line harmonic emissions</td> </tr> </table>	EN 61326	EMC requirements for Class A electrical equipment for measurement, control and laboratory use. ²	IEC 61000-4-2	Electrostatic discharge immunity (Performance criterion B)	IEC 61000-4-3	RF electromagnetic field immunity ³ (Performance criterion A)	IEC 61000-4-4	Electrical fast transient / burst immunity (Performance criterion B)	IEC 61000-4-5	Power line surge immunity (Performance criterion B)	IEC 61000-4-6	Conducted RF immunity (Performance criterion A)	IEC 61000-4-11	Voltage dips and interruptions immunity (Performance criterion B)	EN 61000-3-2	AC power line harmonic emissions
EN 61326	EMC requirements for Class A electrical equipment for measurement, control and laboratory use. ²																
IEC 61000-4-2	Electrostatic discharge immunity (Performance criterion B)																
IEC 61000-4-3	RF electromagnetic field immunity ³ (Performance criterion A)																
IEC 61000-4-4	Electrical fast transient / burst immunity (Performance criterion B)																
IEC 61000-4-5	Power line surge immunity (Performance criterion B)																
IEC 61000-4-6	Conducted RF immunity (Performance criterion A)																
IEC 61000-4-11	Voltage dips and interruptions immunity (Performance criterion B)																
EN 61000-3-2	AC power line harmonic emissions																
Australia / New Zealand Declaration of Conformity - EMC	<p>Complies with EMC provision of Radiocommunications Act per the following standard(s):</p> <table> <tr> <td>AS/NZS 2064.1/2</td> <td>Industrial, Scientific, and Medical Equipment: 1992</td> </tr> </table>	AS/NZS 2064.1/2	Industrial, Scientific, and Medical Equipment: 1992														
AS/NZS 2064.1/2	Industrial, Scientific, and Medical Equipment: 1992																
FCC Compliance	Emissions comply with FCC Code of Federal Regulations 47, Part 15, Subpart B, Class A Limits.																

¹ **To maintain emission requirements when connecting cables to this oscilloscope, use only a high-quality, double-shielded (braid and foil) cable. The cable shield must have low impedance connections to both connector housings. Acceptable cables are listed:**

GPIB	Tektronix part numbers 012-0991-00, -01, -02 and -03
Centronics	Tektronix part number 012-1214-00
RS-232	CA part number 0294-9
VGA Video	LCOM part number CTL3VGAMM-5

² **Emissions which exceed the levels required by this standard may occur when this equipment is connected to a test object.**

³ **≤ 0.5 division waveform displacement, or ≤ 1.0 division increase in peak-to-peak noise when subjected to a 3 V/m electromagnetic field over the frequency range of 80 MHz to 1000 MHz.**

Table 1- 16: Certifications and compliances (cont.)

Category	Standards or description
EC Declaration of Conformity - Low Voltage	<p>Compliance was demonstrated to the following specification as listed in the Official Journal of the European Union:</p> <p>Low Voltage Directive 73/23/EEC, amended by 93/69/EEC</p> <p>EN 61010-1/A2:1995 Safety requirements for electrical equipment for measurement control and laboratory use.</p>
U.S. Nationally Recognized Testing Laboratory Listing	<p>UL3111-1 Standard for electrical measuring and test equipment.</p>
Canadian Certification	<p>CAN/CSA C22.2 No. 1010.1 Safety requirements for electrical equipment for measurement, control, and laboratory use.</p>
Additional Compliance	<p>ISA-S82.02.01-1999 Safety standard for electrical and electronic test, measuring, controlling, and related equipment.</p> <p>IEC61010-1/A2:1995 Safety requirements for electrical equipment for measurement, control, and laboratory use.</p>
Installation (Overvoltage) Category	<p>Terminals on this product may have different installation (overvoltage) category designations. The installation categories are:</p> <p>CAT III Distribution-level mains (usually permanently connected). Equipment at this level is typically in a fixed industrial location.</p> <p>CAT II Local-level mains (wall sockets). Equipment at this level includes appliances, portable tools, and similar products. Equipment is usually cord-connected.</p> <p>CAT I Secondary (signal level) or battery operated circuits of electronic equipment.</p>
Pollution Degree	<p>A measure of the contaminates that could occur in the environment around and within a product. Typically the internal environment inside a product is considered to be the same as the external. Products should be used only in the environment for which they are rated.</p> <p>Pollution Degree 2 Normally only dry, nonconductive pollution occurs. Occasionally a temporary conductivity that is caused by condensation must be expected. This location is a typical office/home environment. Temporary condensation occurs only when the product is out of service.</p>
Safety Class	<p>Class 1 (as defined in IEC 1010-1, Annex H) - grounded product</p>

Typical Characteristics

This section contains tables that list the various *typical characteristics* that describe the TDS 400A Digitizing Oscilloscopes.

Typical characteristics are described in terms of typical or average performance. Typical characteristics are not warranted.

This subsection lists only typical characteristics. A list of warranted characteristics starts on page 1-15.

Table 1-17: Typical Characteristics — Signal Acquisition System

Name	Description		
Accuracy, DC Voltage Measurement, Not Averaged	Measurement Type	DC Accuracy	
	Any Sample	$\pm(1.5\% \times (\text{reading} - \text{Net Offset}^1)) + \text{Offset Accuracy} + 0.13 \text{ div} + 0.6 \text{ mV}$	
	Delta Volts between any two samples ²	$\pm(1.5\% \times \text{reading}) + 0.26 \text{ div} + 1.2 \text{ mV}$	
Frequency Limit, Upper, 100 MHz Bandwidth Limited	100 MHz		
Frequency Limit, Upper, 20 MHz Bandwidth Limited	20 MHz		
Nonlinearity	< 1 DL, differential; \leq 1 DL, integral, independently based ³		
Analog Bandwidth, DC-1 M Ω Coupled with Standard-Accessory Probe Attached	Volts/Div	TDS 420A Bandwidth	TDS 430A and TDS 460A Bandwidth
	5 mV/div-10 V/div	DC-200 MHz	DC-400 MHz
	2 mV/div-4.98 mV/div	DC-150 MHz	DC-250 MHz
	1 mV/div-1.99 mV/div	DC-100 MHz	DC-100 MHz

Table 1-17: Typical Characteristics — Signal Acquisition System (Cont.)

Name	Description				
Step Response Settling Error	Volts/Div Setting	Step Amplitude	Settling Error (%) ⁴		
			20 ns	500 ns	20 ms
	1 mV/div-99.5 mV/div	≤2 V	≤0.5	≤0.2	≤0.1
	100 mV/div-995 mV/div	≤20 V	≤2.0	≤0.5	≤0.2
	1 V/div-10 V/div	≤200 V	≤2.0	≤0.5	≤0.2

- ¹ **Net Offset = Offset - (Position x Volts/Div). Net Offset is the voltage level at the center of the A-D converter dynamic range. Offset Accuracy is the accuracy of this voltage level.**
- ² **The samples must be acquired under the same setup and ambient conditions.**
- ³ **A DL (digitization level) is the smallest voltage level change that can be resolved by the 8-bit A-D Converter with the input scaled to the volts/division setting of the channel used. Expressed as a voltage, a DL is equal to 1/25 of a division times the volts/division setting.**
- ⁴ **The values given are the maximum absolute difference between the value at the end of a specified time interval after the mid-level crossing of the step and the value one second after the mid-level crossing of the step, expressed as a percentage of the step amplitude.**

Table 1-18: Typical Characteristics — Time Base System

Name	Description
Aperture Uncertainty	For real-time or interpolated records having duration ≤1 minute: $\leq(50 \text{ ps} + 0.03 \text{ ppm} \times \text{Record Duration}) \text{ RMS}$ For equivalent time records: $\leq(50 \text{ ps} + 0.06 \text{ ppm} \times \text{WI}^1) \text{ RMS}$
Fixed Error in Sample Time	≤50 ps
External Clock sampling uncertainty	±8 ns
External Clock Edge to Sampling Time Delay	Sample -20 ns (Sample edge is delayed relative the the sample moment.) Hi Res Hi Res averaging starts within ± 8 ns of the clock edge. Averaging stops after 1/(maximum external clock rate ²) Peak Detect Runs continuously at 100 MS/s
External Clock Minimum Prerecord points	55 points before the first visible sample in the record at the maximum clock speed 35 points before the first visible sample in the record at slow clock speeds
External Clock Minimum Postrecord points	25 points after the last visible sample in the record

- ¹ **The WI (waveform interval) is the time between the samples in the waveform record. Also, see the footnotes for *Sample Rate Range* and *Equivalent Time or Interpolated Waveform Rates* in Table 1-4 on page 1-9.**
- ² **You set the maximum external clock rate using the Horizontal Clock menu.**

Table 1-19: Typical Characteristics — Triggering System

Name	Description		
Error, Trigger Position, Edge Triggering	Acquire Mode		Trigger-Position Error^{1,2}
	Sample, Hi-Res, Average		$\pm(1 WI + 1 ns)$
	Peak Detect, Envelope		$\pm(2 WI + 1 ns)$
Holdoff, Variable, Main Trigger, Internal Clock and non TV Trigger	Main Horizontal Scale	Minimum Holdoff	Maximum Holdoff
	$\leq 100 ns/div$	1 μs	5 \times Min Holdoff
	$\geq 100 ms/div$	1 s	5 \times Min Holdoff
	Otherwise	10 \times sec/div	5 \times Min Holdoff
Holdoff, Variable, External Clock	0 to 100 ms		
Auto Trigger Operation, External Clock	Auto triggers 2 s after the last normal trigger or appropriated trigger mode is entered		
Lowest Frequency for Successful Operation of "Set Level to 50%" Function	20 Hz		
Sensitivity, Edge Trigger, Not DC Coupled ³	Trigger Coupling		Typical Signal Level for Stable Triggering
	AC		Same as DC-coupled limits ⁴ for frequencies above 60 Hz. Attenuates signals below 60 Hz
	Noise Reject		Three and one-half times the DC-coupled limits ⁴
	High Frequency Reject		One and one-half times the DC-coupled limits ⁴ from DC to 30 kHz. Attenuates signals above 30 kHz
	Low Frequency Reject		One and one-half times the DC-coupled limits ⁴ for frequencies above 80 kHz. Attenuates signals below 80 kHz
Video Mode (Option 05 Equipped Instruments Only)	<p>Line Rate Class: Four classes are provided as follows</p> <ul style="list-style-type: none"> ■ NTSC, which provides a default line rate compatible with the NTSC standard (525/60) ■ PAL, which provides a default line rate compatible with the PAL standard (625/50) ■ SECAM, which provides a default line rate compatible with the SECAM standard (625/50) ■ Custom, which provides user selectable line rate ranges (see <i>Custom Line Rate Ranges</i> below) <p>Custom Line Rate Ranges: 15 kHz-20 kHz, 20 kHz-25 kHz, 25 kHz-35 kHz, and 35 kHz-64 kHz</p> <p>Holdoff: Automatically adjusts to 58 ms (nominal) for NTSC class; to 150 ms (nominal) for PAL and SECAM. A holdoff of 0 to 100 typically covers a range of 1 to 400 ms</p> <p>Triggerable on Field Selections: Odd, Even, or Both</p> <p>Delayed Acquisition: Settable for delay by line number or runs after time delay</p>		
Frequency, Maximum for Events Delay ⁵	90 MHz		

Table 1-19: Typical Characteristics — Triggering System (Cont.)

Name	Description
Width, Minimum Pulse and Rearm, Events Delay ⁶	5 ns

- ¹ The trigger position errors are typically less than the values given here. These values are for triggering signals having a slew rate at the trigger point of ± 0.5 division/ns.
- ² The waveform interval (WI) is the time between the samples in the waveform record. Also, see the footnote for the characteristics *Sample Rate Range* and *Equivalent Time or Interpolated Waveform Rates* in Table 1-4 on page 1-9.
- ³ The minimum sensitivity for obtaining a stable trigger. A stable trigger results in a uniform, regular display triggered on the selected slope. The trigger point must not switch between opposite slopes on the waveform, and the display must not “roll” across the screen on successive acquisitions. The TRIG'D LED stays constantly lighted when the SEC/DIV setting is 2 ms or faster but may flash when the SEC/DIV setting is 10 ms or slower.
- ⁴ See the characteristic *Sensitivity, Edge-Type Trigger, DC Coupled* in Table 1-12, which begins on page 1-18.
- ⁵ The maximum frequency for a delaying events input.
- ⁶ The minimum pulse width and rearm width required for recognizing a delaying event.

Table 1-20: Typical Characteristics — Data Handling

Name	Description
Time, Data-Retention, Nonvolatile Memory ^{1,2}	Internal batteries, installed at time of manufacture, have a life of ≥ 5 years when operated and/or stored at an ambient temperature from 0° C to 50° C. Retention time of the nonvolatile memories is equal to the remaining life of the batteries
Nonvolatile Memory Save Time	10 seconds
Floppy Disk Drive Capacity	3.5 in. floppy disk, 720 KB or 1.44 MB, compatible with DOS 3.3 format for storing waveforms, hard copies, and instrument setups

- ¹ The time that reference waveforms, stored setups, and calibration constants are retained when there is no power to the oscilloscope.
- ² Data is maintained by lithium poly-carbon monofluoride.

Installation

This chapter contains information about supplying operating power, the operating environment, applying and interrupting power, repackaging for shipment, and installed options.

Supplying Operating Power

STOP. Read all information and heed all warnings in this chapter before connecting the digitizing oscilloscope to a power source.



WARNING. AC POWER SOURCE AND CONNECTION. The digitizing oscilloscope operates from a single-phase power source. It has a three-wire power cord and a two-pole three-terminal grounding type plug. The voltage to ground (earth) from either pole of the power source must not exceed the 250 V_{RMS} maximum rated operating voltage.

Before making connection to the power source, be sure the digitizing oscilloscope has a suitable two-pole three-terminal grounding-type plug.

GROUNDING. This instrument is safety Class 1 equipment (IEC designation). All accessible conductive parts are directly connected through the grounding conductor of the power cord to the grounded (earthing) contact of the power plug.

The power input plug must be inserted only in a mating receptacle with a grounding contact where earth ground has been verified by a qualified service person. Do not defeat the grounding connection. Any interruption of the grounding connection can create an electric shock hazard.

For electric shock protection, the grounding connection must be made before making connection to the oscilloscope input or output terminals.

Power Cord Information

A power cord with appropriate plug configuration is supplied with each digitizing oscilloscope. Table 2-1 gives the color coding of the conductors in the power cord. If you require a power cord other than the one supplied, refer to Table 2-2.

Table 2-1: Power-Cord Conductor Identification

Conductor	Color	Alternate Color
Ungrounded (Line)	Brown	Black
Grounded (Neutral)	Light Blue	White
Grounded (Earthing)	Green/Yellow	Green

Table 2-2: Power Cord Identification

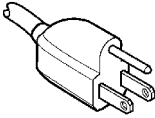
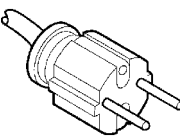
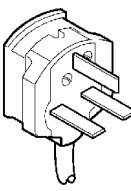
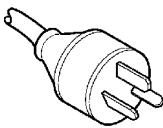
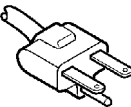
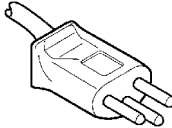
Plug Configuration	Normal Usage	Option Number
	North America 125 V	Standard
	Europe 230 V	A1
	United Kingdom 230 V	A2
	Australia 230 V	A3
	North America 230 V	A4
	Switzerland 230 V	A5

Operating Voltage

The line voltage ranges and their associated line frequency ranges over which this oscilloscope operates are listed in Chapter 1 *Specification*. See *Source Voltage and Frequency* on page NO TAG for those ranges.



CAUTION. Before stepping the source line voltage from one range to a higher range, set the principal power switch (rear panel) to its OFF position. Failure to do so can damage the oscilloscope.

There are two fuses. Either fuse may be used throughout the line voltage and frequency ranges. These two fuses are not totally interchangeable as each requires a different fuse cap. The fuses and their caps are listed by part number in Chapter 10, *Mechanical Parts List*.

Memory Backup Power

Replaceable lithium batteries maintain internal memory modules to allow the digitizing oscilloscope to retain the following data upon loss of the AC power source: stored adjustment constants, saved front-panel settings, current front-panel settings (oscilloscope status), and saved waveforms.

These batteries have a shelf life of about five years. Partial or total loss of stored settings upon powering on may indicate that you need to replace the batteries.

Operating Environment

The following environmental requirements are provided to ensure proper operation and long oscilloscope life.

Operating Temperature

Operate the oscilloscope where the ambient air temperature is between 0° C and +50° C, and store the oscilloscope at an ambient temperature from -40° C to +75° C. After storage at temperatures outside the operating limits, allow the chassis to stabilize at a safe operating temperature before applying power.

Ventilation Requirements

The digitizing oscilloscope is cooled by air drawn in and exhausted through its cabinet side panels by an internal fan. To ensure proper cooling of the oscilloscope, allow at least 50.8 mm (2 inches) clearance on both sides and 19 mm ($\frac{3}{4}$ inch) on the bottom of the digitizing oscilloscope. (The feet on the bottom of the oscilloscope provide the required clearance when set on flat surfaces.) The top of the oscilloscope does not require ventilation clearance.



CAUTION. If air flow is restricted, the power supply of the digitizing oscilloscope may temporarily shut down.

Applying and Interrupting Power

Consider the following information when you power up or power down the oscilloscope or when power is interrupted due to an external power failure.

Power-On Upon powering on, the oscilloscope runs its power-on self check. If the self check passes, the oscilloscope displays a “passed” status message and a prompt to press CLEAR MENU to continue. If the self check fails, the oscilloscope displays a diagnostic log that identifies the area(s) that failed and a prompt to press CLEAR MENU to continue. See Chapter 6, *Maintenance*, for information on diagnostics and fault isolation.

Power-Off



CAUTION. *DO NOT power down the oscilloscope when either running a signal path compensation or when doing any of the adjustments described in Chapter 5, Adjustment Procedures. To do so might result in the loss of internally stored adjustment constants.*

In general, do not power off the oscilloscope when doing operations that affect the data types listed in Table 2-3. Wait for the oscilloscope to finish the operation when doing adjustments, saving waveforms, or saving setups. After operations complete, wait at least four more seconds before turning the power off.

Improper power-down or unexpected loss of power to the oscilloscope can result in corruption of non-volatile RAM (NVRAM). The following table describes the messages displayed when power is restored after an abnormal power-down.

Table 2-3: Effects of Corrupted Data

Corrupted Data Type	Results
Adjustment Constants:	
■ Signal Path Compensation	A signal path compensation is required.
■ Voltage Reference	A voltage reference adjustment is required (Chapter 5)
■ Low or High Frequency Response	A frequency response adjustment is required (Chapter 5)
■ Trigger Skew	A trigger skew adjustment is required (Chapter 5)
Error Log	Errors logged are lost

Table 2-3: Effects of Corrupted Data (Cont.)

Corrupted Data Type	Results
Reference Waveforms	Waveform Lost
Saved Setups	Setup Lost

Repackaging Instructions

Use a corrugated cardboard shipping carton having a test strength of at least 125 kg (275 pounds) and with an inside dimension at least 152.4 mm (6 inches) greater than the oscilloscope dimensions. (The original shipping carton, if available, meets these requirements.)

If the oscilloscope is being shipped to a Tektronix Service Center, enclose the following information: the owner's address, the name and phone number of a contact person, the type and serial number of the oscilloscope, the reason for returning to oscilloscope, and a complete description of the service required.

Seal the shipping carton with an industrial stapler or strapping tape.

Mark the address of the Tektronix Service Center and also your own return address on the shipping carton in two prominent locations.

Installed Options

Your oscilloscope may be equipped with one or more options. Except for the line-cord options described by Table 2-2 (on page 2-2 of this chapter), all options and optional accessories are listed and described in Chapter 7, *Options*. For further information and prices of oscilloscope options, see your Tektronix Products catalog or contact your Tektronix Field Office.

Operating Information

Before doing service, read the following operating instructions. These instructions are at the level appropriate for servicing this digitizing oscilloscope. The complete operators instructions are found in the user manual.

Additional instructions are integrated into the service procedures found in later chapters of this manual. For instance, the procedures found in the *Performance Verification* chapter, starting on page NO TAG, contain instructions for making the front-panel settings required to check each oscilloscope characteristic included there. Also, the general instructions for operating the internal diagnostic routines are found in the, *Maintenance* chapter, starting on page 6-1. You may also find the *Product Description*, starting on page 4-1, useful for understanding how the oscilloscope functions.

Screen Layout

The screen layout is illustrated in Figure 2-1 on page 2-8. Note that the figure illustrates a full graticule; you may also select a grid, crosshair, or frame graticule from the display menu.

Basic Procedures

How to Power On

Push the principal power switch found on the rear panel of the digitizing oscilloscope, then push the **ON/STBY** (standby) switch to toggle the digitizing oscilloscope into operation. The switch at the rear panel is the true power disconnect switch. The **ON/STBY**(standby) switch simply toggles operation on and off.



WARNING. *The principal power switch at the rear panel is the true power disconnect switch. The **ON/STBY** (standby) switch simply toggles operation on and off. When connected to a power source and when the principal power switch is on, some power supply circuitry in this digitizing oscilloscope is energized regardless of the setting of the **ON/STBY** switch.*

When connecting or disconnecting the line cord to or from the power source, the principal power switch should be off.

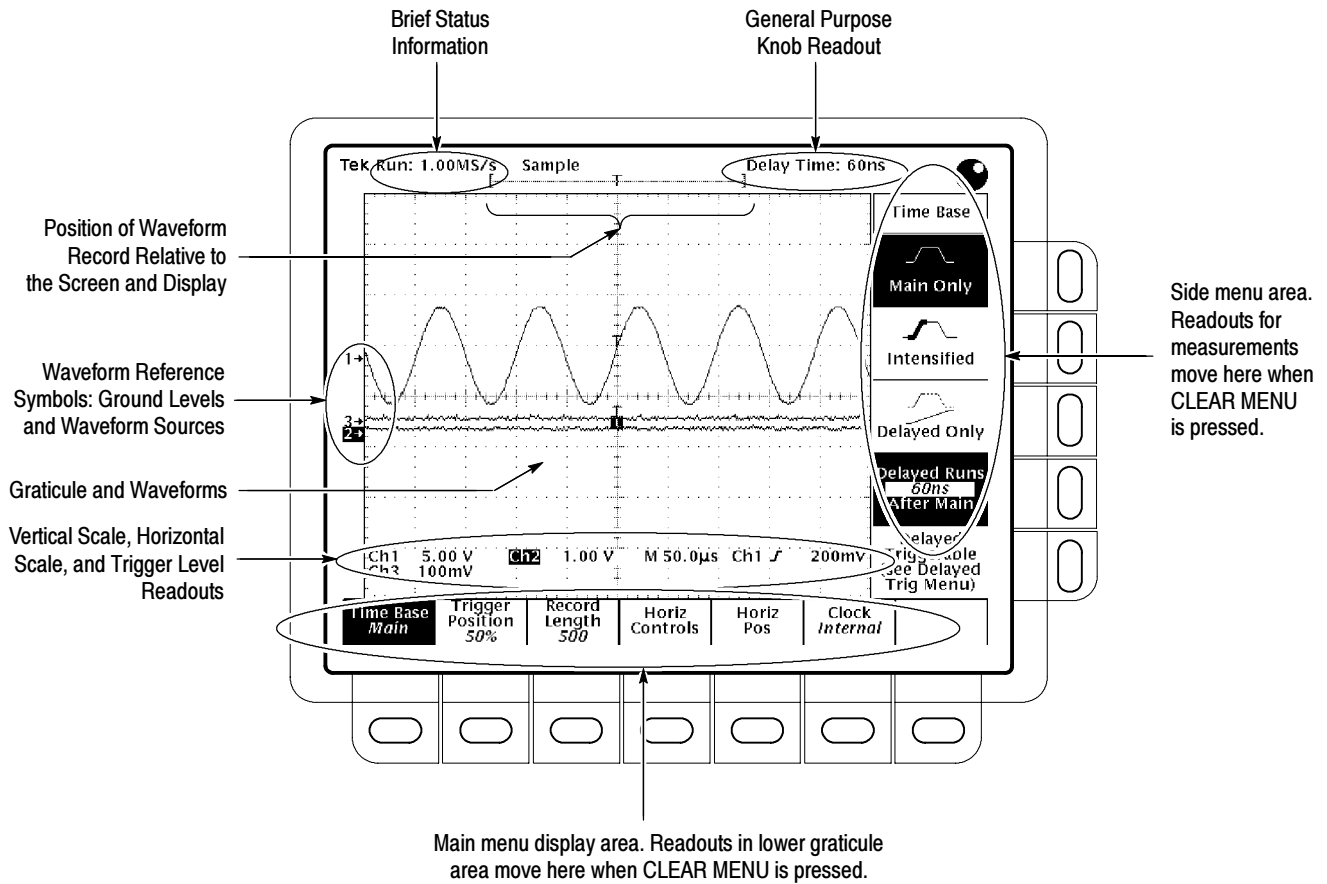

Figure 2- 1: Map of Display Functions

Using Help

Push the **HELP** front-panel button to enter help mode. Front-panel knobs and buttons now display information about their function when turned or pushed. Push **HELP** again to exit help mode.

To get help information on a menu item, display the menu desired (if you are in help mode, exit help first). Push **HELP**. Now the menu buttons display information about their function when pushed.

Using the Status Menu

Push the **SHIFT** button, and then press the **STATUS** front-panel button. Then press the **STATUS** main-menu button to display the status menu. The messages reflect the state of the acquisition system, whether it is running or stopped (and if it is stopped, why), as well as setup-related information.

Setting Functions

You set most functions by either using one or two front-panel buttons or knobs, or by pushing a front-panel button to use a main menu, and then a side menu to set the function. The following steps illustrate both procedures.

1. Locate the block that contains the function to be set.

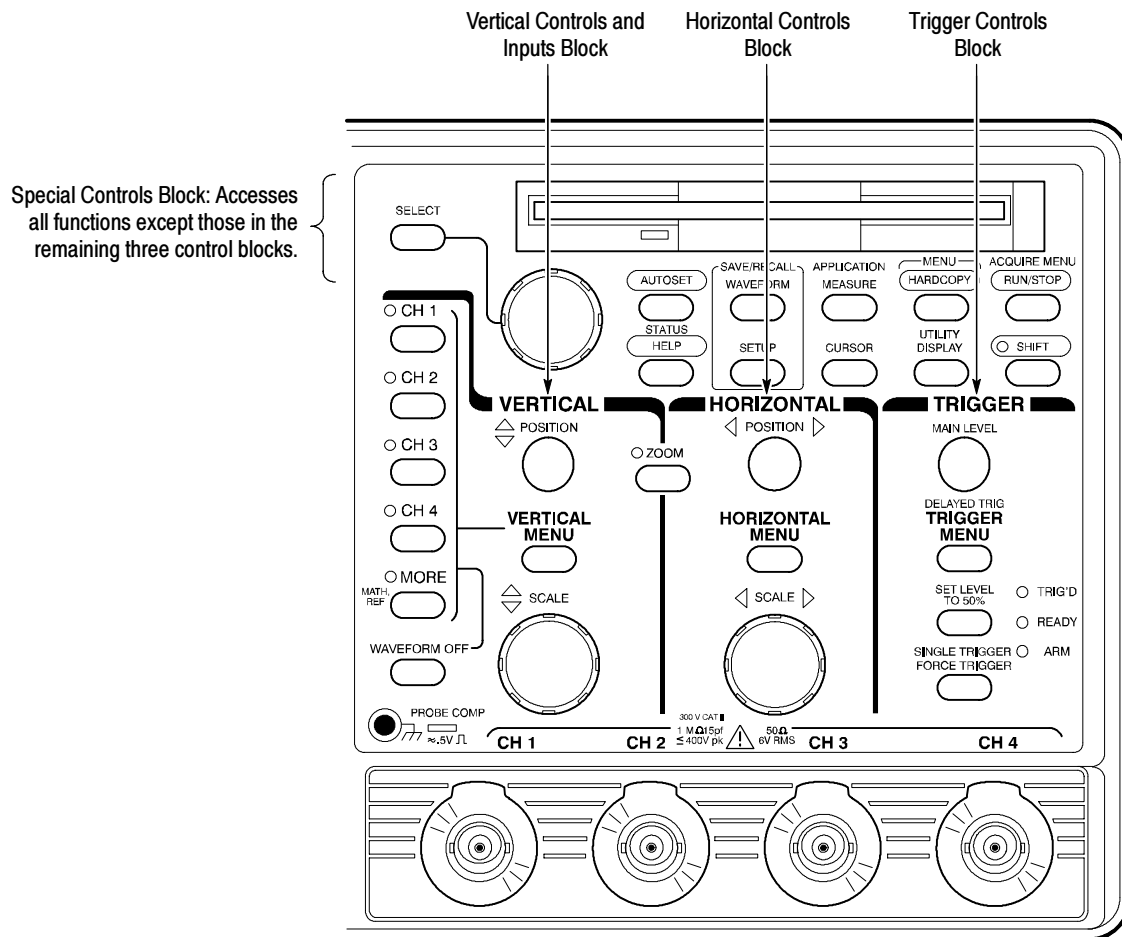

2. Select the waveform source(s). Position, scale, and set trigger level for waveform source(s) directly from the front-panel. (Note that parentheses-enclosed numbers appear within the following steps. Each number refers to the control(s) labeled with the same number in the figure that precedes the step.)

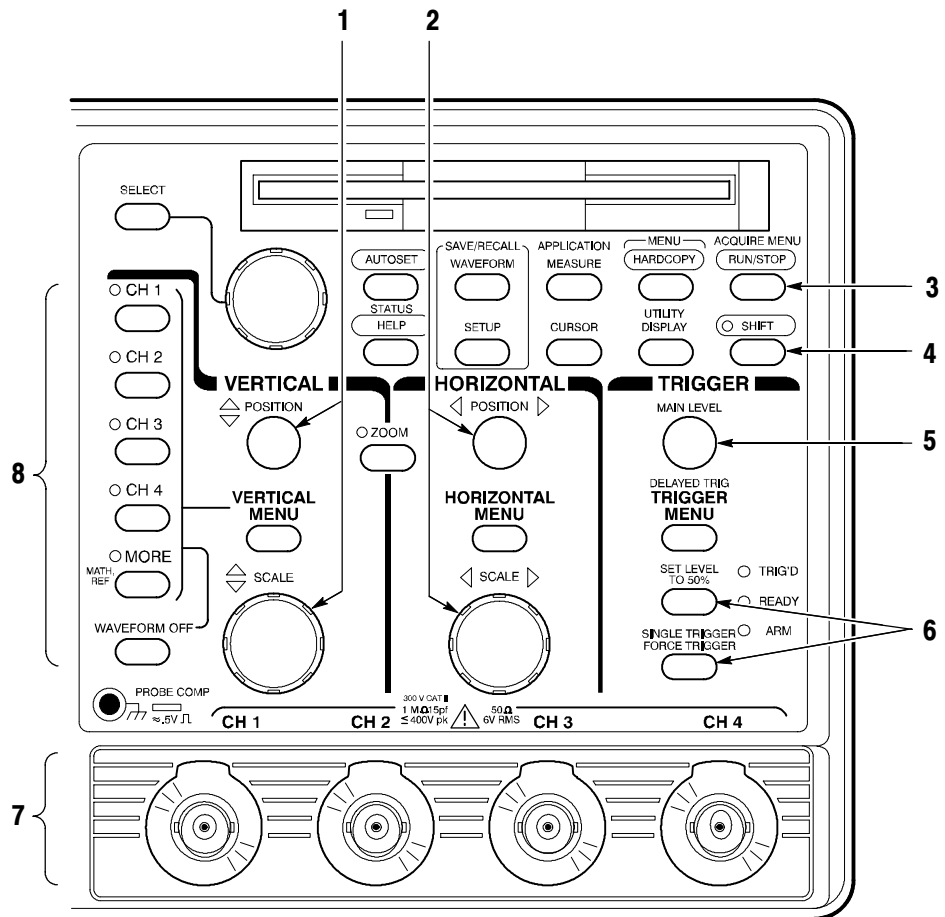

- a. Input waveforms into these channels (7). Example: **CH 1**.
- b. Push any channel button (8) to display its waveform. The last channel selected determines which waveform is positioned and scaled. The indicator above the channel last selected is lighted. Example: Push **CH 1**; then **CH 2**.
- c. Vertically (1) and horizontally (2) scale and position the waveform(s) selected. Example: Set the scale to 100 mV/div, and center the waveform on screen.
- d. Stop and start acquiring waveforms (3). Example: Push **RUN/STOP** if not acquiring.

- e. Adjust trigger level (5) to trigger the waveform(s) selected, or use these buttons (6) to either set a trigger level at the mid-amplitude level of the selected waveform or to force a single trigger. Example: Push **SET LEVEL TO 50%**.
3. Set all other functions using menus.
- a. Choose the waveform source (8) first if setting a vertical function; else skip to step b. Example: Push **CH 2**.
 - b. Push **SHIFT** (4) if the function to be set is highlighted in blue; else skip to step c.

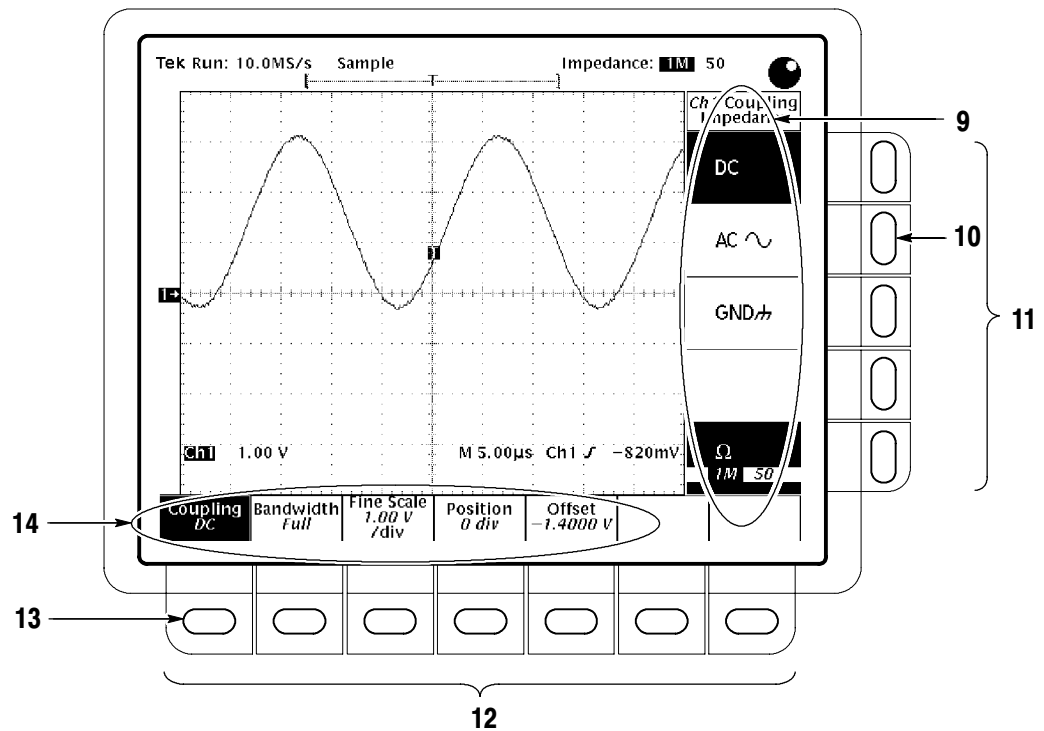

- c. Push the front-panel button that corresponds to the menu containing the function. A main menu (14) for selecting among related functions appears. Example: Push **VERTICAL MENU**.

Note the two labels: the top label is a function to choose from; the bottom label tells you the current setting for that function. **Offset** is currently set to **-1.4 V**.

- d. Select a function from the main menu using the main menu buttons (12). A side menu for selecting among the available settings for that function appears. Example: Push **Coupling** (13).

- e. Select the setting for the function from the side menu (9) using the side menu buttons (11). Example: Push **AC** (10).

How to Set Complex Functions

A few functions require more than just two levels (main and side) of menus to completely specify their settings. In such cases, either the main menu, the side menu, or both are modified to supply additional choices. The procedures that follow show both schemes.

1. Set up a function using pop-up menus:

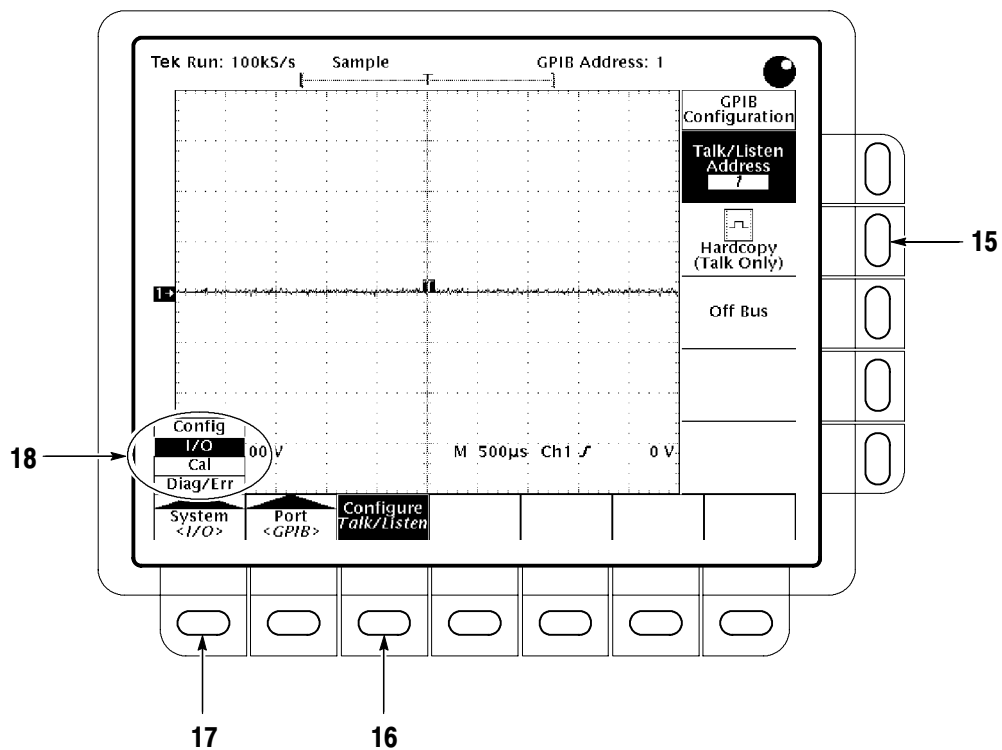

- a. For some selections, pushing a main menu button pops up a menu (18) of subfunctions. Example: Push **SHIFT**; then push **UTILITY**. Now push **System** (17).

Note the pop-up menu for **System** is set to **I/O** (input/output). All the main menu buttons to the right of the pop-up menu are labeled with subfunctions of **I/O**.

- b. Pushing the button that popped up the menu (17) toggles through the pop-up menu choices. Example: Repeatedly push **System** to toggle through the pop-up menu. Notice the other main-menu button labels change accordingly. Toggle back to **I/O**.

- c. Complete the setting of the desired mode by selecting from the main menu and the side menu that results. Example: Push **Configure** (16), and then push **Hardcopy (Talk only)** (15).
2. Set up a function using the general purpose knob (20). (The examples of possible menu selections in the substeps that follow assume you have pushed **TRIGGER MENU**.)

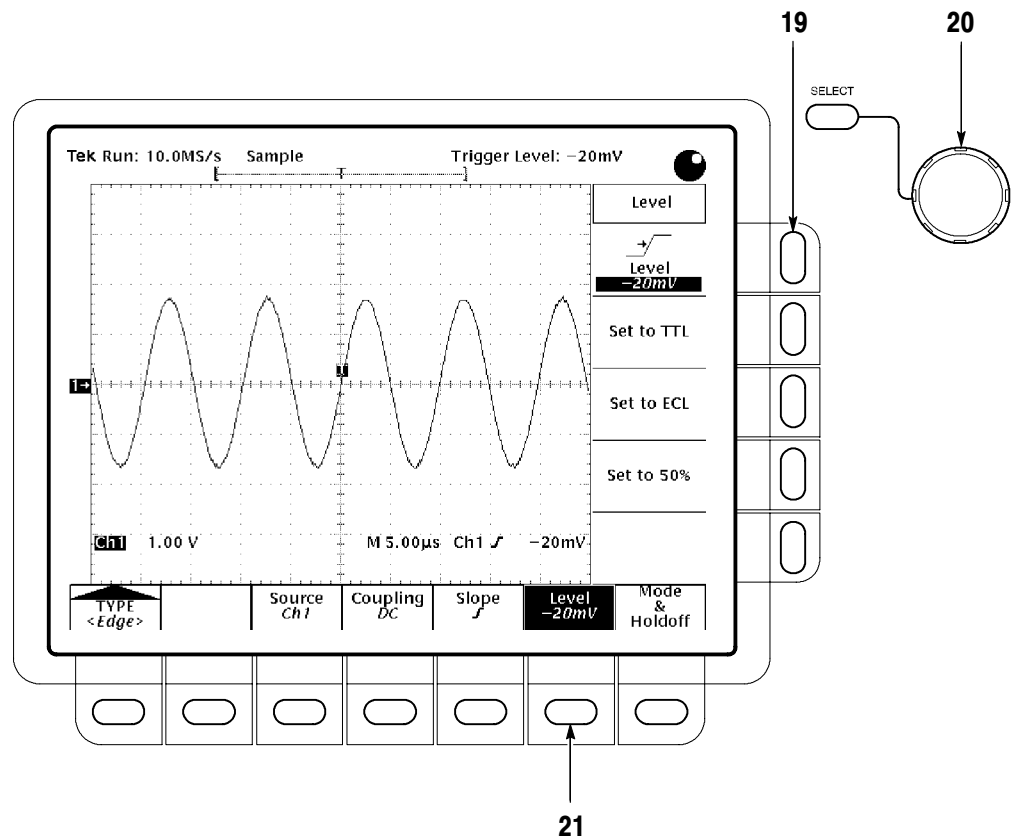

- a. Pushing some main menu buttons displays a side menu with labels containing readouts that you can vary. Example: Push **Level** (21).
- b. Pushing the side-menu button assigns the knob to control the readout appearing in the button label. It also copies the readout to the general purpose knob readout area in the right corner of the screen. Example: Push **Level** (19).
- c. Use the general purpose knob (20) to adjust the trigger level to the setting desired. Example: Turn the knob to **-20 mV**.

More About the General Purpose Knob. As you have just seen, the general purpose knob is used to extend the number of choices available to a side menu button. You can also assign the general purpose knob to control additional functions. Some of these additional functions include:

- Cursor positioning
- Display intensities
- Delay time
- Number of events
- Trigger position
- Holdoff
- Offset
- Variable persistence
- File system

In all cases, the menus are used to select the function to which the general purpose knob is assigned. The following attributes apply to this knob:

- Depending on the function it is assigned to control, the general purpose knob varies numerical readouts, positions objects (cursors) on screen, or selects between icon-label settings that show up in side-menu labels.
- The general purpose knob has a readout area at the upper-right corner of the screen. (See Figure 2-1.) This readout always reflects the name and value of the function that the general purpose knob is currently controlling.
- The general purpose knob is affected by the **SHIFT** button. Pressing shift toggles the knob between its fine and coarse modes. Fine mode is used for most adjustments; coarse mode is used to traverse large parts of the adjustment range in less time.
- Whenever the general purpose knob assignment is changed, a knob icon appears immediately to the left of the general purpose knob readout to notify you of the assignment change. The icon is removed as soon as you use the general purpose knob to change the value of the function it is assigned to.
- To assign the general purpose knob to control a function, display the menu containing the function; then select the function. (Note that the general purpose knob cannot control all functions.)

- Whenever the menu is removed, the general purpose knob is not assigned and does not control a function. (An exception is the cursor function. If cursors are turned on, removing the menu leaves the knob assigned to control the cursors until reassigned by selecting another menu and function that uses the knob.)
- The general purpose knob also has a **SELECT** button. Use the select button to toggle the knob between the control of either of the two cursors displayed when H-bar or V-bar cursors are turned on in the cursor menu, to select the active graticule in zoom preview, to traverse the file system, and to enter characters when naming files.

Display and Utility Menus. Using the techniques described for using menus, you can access and change functions in the display menu and utilities menu. In the Display menu, you can set the following functions:

- Intensity: waveforms, readouts, and graticule
- Style of waveform display(s): vectors or dots, intensified or non-intensified samples, and infinite or variable persistence
- Display format: XY or YT
- Graticule format: full, grid, crosshair, frame, NTSC, and PAL
- Waveform interpolation filter and readout options

From the Utility menu, you can configure the GPIB port (talk/listen, address, etc.) and access internal routines for self diagnostics and self compensation. Instructions for setting up communication over the GPIB are found in the *Adjustment Procedures*, starting on page 5-1.

Theory of Operation

This chapter describes the electrical operation of the Tektronix TDS 420A, TDS 430A, and TDS 460A Digitizing Oscilloscopes using the major circuit blocks or modules.

This chapter has two main parts:

- **Logic Conventions** describes how logic functions are discussed and represented in this manual.
- **Module Overview** describes circuit operation from a functional block perspective.

Logic Conventions

The digitizing oscilloscope contains many digital logic circuits. This manual refers to these circuits with standard logic symbols and terms. Unless otherwise stated, all logic functions are described using the positive-logic convention: the more positive of the two logic levels is the high (1) state, and the more negative level is the low (0) state. Signal states may also be described as “true” meaning their active state or “false” meaning their non-active state. The specific voltages that constitute a high or low state vary among the electronic devices.

Active-low signals are indicated by a tilde prefixed to the signal name (~RESET). Signal names are either active-high, active-low, or have both active-high and active-low states.

Module Overview

This module overview describes the basic operation of each functional circuit block as shown in Figure 9-2 on page 9-8.

General The digitizing oscilloscope is a portable, multichannel instrument. Each channel provides a calibrated vertical scale factor. All channels can be acquired simultaneously.

Input Signal Path A signal enters the oscilloscope through a probe connected to a BNC on the A05 Attenuator board.

Attenuators. Circuitry in the attenuator selects the input coupling, the termination, and the attenuation factor. The processor system controls the attenuators.

For example, if 50 Ω input termination is selected and the input is overloaded, the processor system switches the input to the 1 M Ω position. The preamplifier in the A05 Attenuator amplifies the input signals.

Probe Coding Interface. Probe coding interface signals pass through the A06 Front Panel to the processor system.

Jumper. Signals from the attenuators pass through the A08 Jumper board to the acquisition system.

Acquisition System. The acquisition system converts the analog input signals to digital signals and controls the acquisition process under direction of the processor system. The acquisition system includes the trigger, acquisition timing, and acquisition mode generation and control circuitry.

D1 Bus. The acquisition system passes the digital values representing the acquired waveform through the D1 bus to the A09 DSP board (TriStar). This happens after a waveform acquisition is complete if the digital signal processor (DSP) requests the waveform.

Processor System. The processor system consists of a 68020 microprocessor that controls the entire instrument. It includes the firmware program for the oscilloscope. The firmware can be reprogrammed by using the GPIB and an external software package. The processor system also includes a GPIB interface. The processor can display text and symbols (that is, cursors, but not waveforms) by passing them to the A02 Display board.

DSP. The digital signal processor processes each waveform as directed by software downloaded from the system processor. Waveforms to be displayed are passed on to the A02 Display board.

Display. Text and waveforms are processed by different parts of the A02 Display circuitry. The display sends the text and waveform information to the A26 Monitor assembly as a video signal. The display circuitry also generates and sends vertical (VSYNC) and horizontal (HSYNC) sync signals to the A26 Monitor assembly. A VGA-compatible video output is available at the rear of the oscilloscope.

- Monitor Assembly** All information (waveforms, text, graticules, and pictographs) is displayed by the A20 CRT Driver. The driver generates the high voltages necessary to drive the CRT. It also contains the video amplifier, horizontal oscillator, and the vertical and horizontal yoke driver circuitry. The monitor gets its supply voltages from the A25 Low Voltage Power Supply through the A01 Backplane and the A07 Auxiliary Power boards.
- Front Panel** The processor system sends instructions to and receives information from the Front Panel Processor on the A06 Front Panel board. The Front Panel Processor reads the front-panel switches and pots. Any changes in their settings are reported to the processor system. The Front Panel Processor also turns the LEDs on and off, generates the bell signal, and generates the probe compensation signal PROBE ADJ. The Front Panel Processor also processes the probe coding interface signals.
- The ON/STBY switch is not read by the Front Panel Processor. The signal passes through the A06 Front Panel board to the A03 CPU board. There it's converted to a control signal for the low voltage power supply.
- Rear Panel** The GPIB connector provides access to stored waveforms and allows external control of the oscilloscope. Other connectors accessible from the rear panel are the AUX TRIGGER/EXT CLOCK and VIDEO.
- Aux Power** **B010100 - B079999 instruments only.** The A07 Auxiliary Power circuitry includes the principal power switch, fuse, line trigger transformer, and line filter. It also distributes power to the monitor and fan.
- Power Factor Module** **B080000 and up instruments.** The Power Factor Module produces high voltage DC for delivery to the Low Voltage Power Supply Module input. Power is taken from the AC input by drawing current in a waveshape similar to and in phase with that of the voltage waveshape. AC input connector, fuse, and line trigger are included on this module.

Low Voltage Power Supply

The low voltage power supply is a switching power converter. It supplies power to all oscilloscope circuitry. The low voltage power supply sends all of its power to the A01 Backplane where it is distributed to all other circuitry.

B080000 and up instruments. The principal POWER switch, located on the rear panel, controls all power to the oscilloscope including the low voltage power supply.

The ON/STBY switch, located on the front panel, controls all of the power to the oscilloscope except for part of the circuitry in the low voltage power supply.

Fan

The fan provides forced air cooling for the oscilloscope. It connects to +12 V on the A01 Backplane through the A07 Auxiliary Power board.

Battery

The battery provides power to memory circuits that maintain calibration constants and oscilloscope setups when the oscilloscope power is off.

Performance Verification Procedures

Two types of Performance Verification procedures can be performed on this product: *Brief Procedures* and *Performance Tests*. You may not need to perform all of these procedures, depending on what you want to accomplish:

- To rapidly confirm that this oscilloscope functions and is adjusted properly, just do the procedures under *Self Tests*, which begin on page 4-5.

Advantages: These procedures are quick to do, require no external equipment or signal sources, and perform extensive functional and accuracy testing to provide high confidence that the oscilloscope will perform properly. Use these procedures as a quick check before making a series of important measurements.

- To further check functionality, first do the *Self Tests* just mentioned; then do the procedures under *Functional Tests* that begin on page 4-7.

Advantages: These procedures require minimal additional time to perform, require no additional equipment other than a standard-accessory probe, and more completely test the internal hardware of this oscilloscope. Use these procedures to quickly determine if the oscilloscope is suitable for putting into service, such as when it is first received.

- If more extensive confirmation of performance is desired, do the *Performance Tests*, beginning on page 4-15, after doing the *Functional* and *Self Tests* just referenced.

Advantages: These procedures add direct checking of warranted specifications. They require more time to perform and suitable test equipment is required. (See *Equipment Required* on page 4-16.)

If you are not familiar with operating this oscilloscope, read *Operating Information* in Chapter 2 of this manual. These instructions will acquaint you with the use of the front-panel controls and the menu system.

Throughout these procedures the following conventions apply:

- Each test procedure uses the following general format:

Title of Test

Equipment Required

Prerequisites

Procedure

- Each procedure consists of as many steps and substeps as required to do the test. Steps and substeps are sequenced as follows:
 1. First Step
 - a. First Substep
 - b. Second Substep
 2. Second Step
- In steps and substeps, the lead-in statement in italics instructs you what to do, while the instructions that follow tell you how to do it: in the example step below, “*Initialize the oscilloscope*” by doing “Press save/recall **SETUP**. Now, press the main-menu button...”

Initialize the oscilloscope: Press save/recall **SETUP**. Now, press the main-menu button **Recall Factory Setup**; then the side-menu button **OK Confirm Factory Init**.
- Where instructed to use a front-panel button or knob, or select from a main or side menu, or verify a readout or status message, the name of the button or knob appears in boldface type: “press **SHIFT**; then **ACQUIRE MENU**,” “press the main-menu button **Coupling**,” or “verify that the status message is *Pass*.”

STOP. *This symbol is accompanied by information you must read to do procedures properly.*

- Refer to Figure 4-1: “Main menu” refers to the menu that labels the seven menu buttons under the display; “side menu” refers to the menu that labels the five buttons to the right of the display.

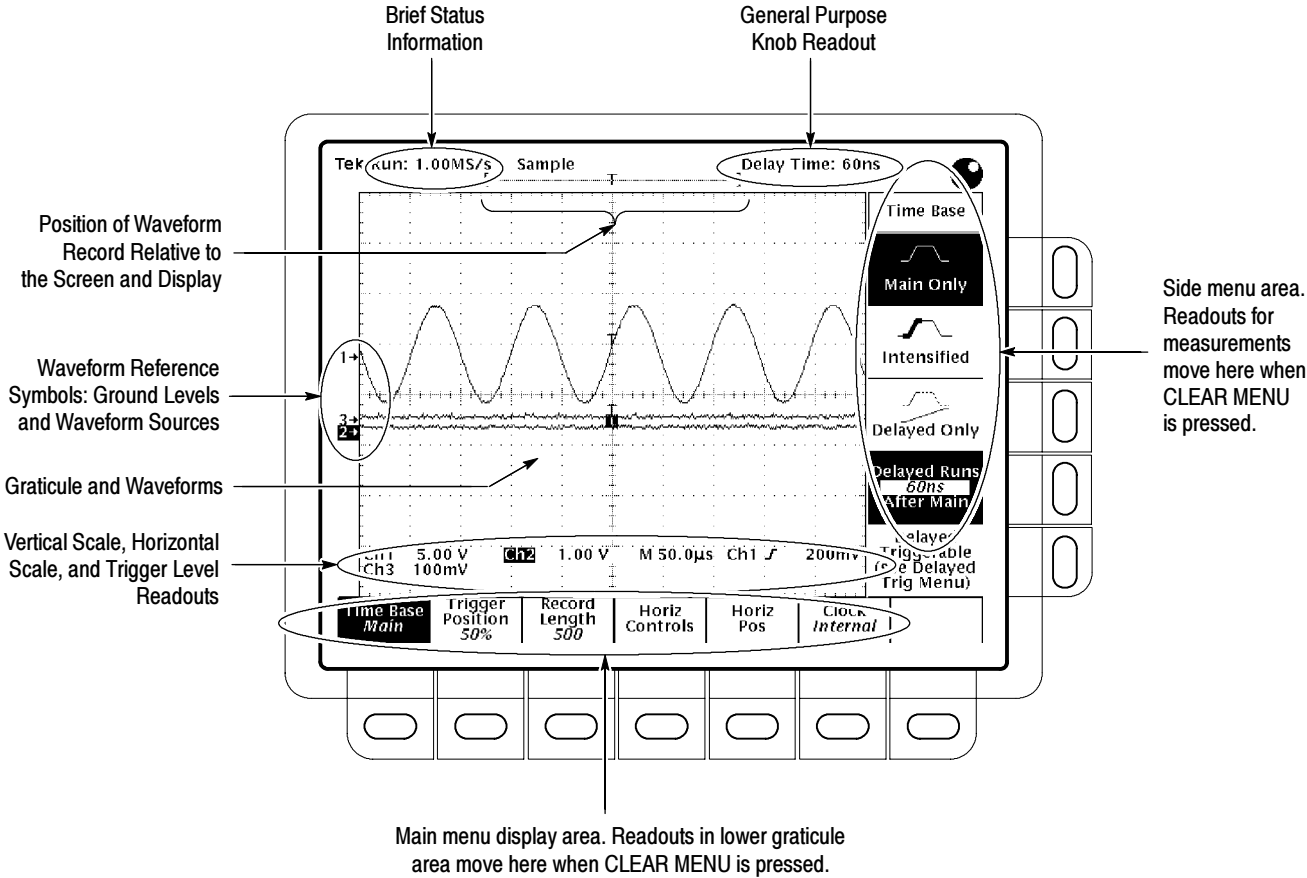

Figure 4-1: Map of Display Functions

Brief Procedures

The *Self Tests* use internal routines to confirm basic functionality and proper adjustment. No test equipment is required to do these test procedures.

The *Functional Tests* use the probe-adjust output at the front panel as a test-signal source for further verifying that the oscilloscope functions properly. A standard-accessory probe, included with this oscilloscope, is the only equipment required.

Self Tests

This procedure uses internal routines to verify that this oscilloscope functions and passes its internal self tests and signal path compensations. It also confirms that the oscilloscope was adjusted properly at the time it was last adjusted. No test equipment or hookups are required.

Verify Internal Adjustment, Self Compensation, and Diagnostics

Equipment Required	None
Prerequisites	Power on the digitizing oscilloscope and allow a 20 minute warm-up before doing this procedure.

1. *Verify that internal diagnostics pass:* Do the following substeps to verify that the internal diagnostics passed.
 - a. *Display the system diagnostics menu:*
 - Press **SHIFT**; then press **UTILITY**.
 - Repeatedly press the main-menu button **System** until **Diag/Err** is highlighted in the menu that pops up.
 - Repeatedly press the main-menu button **Area** until **All** is highlighted in the menu that pops up.
 - b. *Run the system diagnostics:* Press the main-menu button **Execute**; then press the side-menu button **OK Confirm Run Test**.
 - c. *Wait:* The internal diagnostics do an exhaustive verification of proper oscilloscope function. This verification takes up to two minutes. While it progresses, a variety of test patterns flash on screen. When finished, the resulting status appears on the screen.
 - d. *Confirm no failures are found:* Verify that no failures are found and reported on screen.

- e. Confirm the four adjustment sections have passed status:
 - Press **SHIFT**; then press **UTILITY**.
 - Press the main menu button **System** until **Cal** is highlighted in the pop-up menu.
 - Verify that the word **Pass** appears in the main menu under the following menu labels: **Voltage Reference**, **High Frequency Response**, **Low Frequency Response**, and **Trigger Skew**. (See Figure 4-2.)

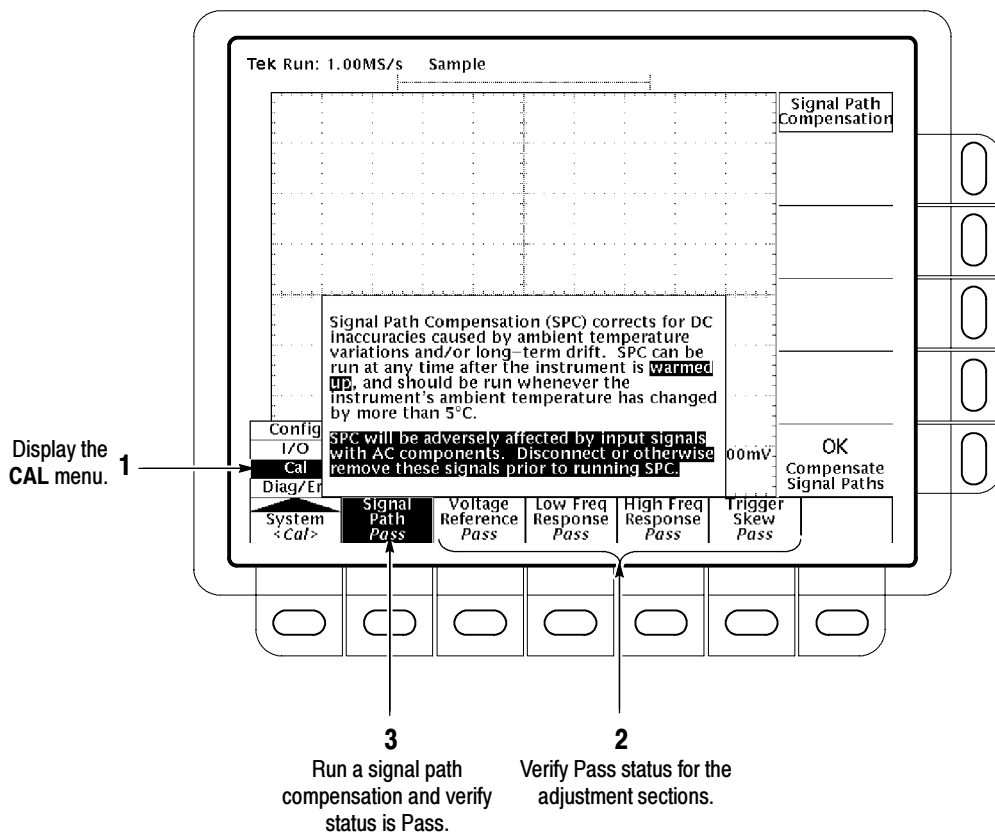

Figure 4-2: Verifying Adjustments and Signal Path Compensation

This oscilloscope lets you compensate the internal signal path used to acquire the waveforms you acquire and measure. By executing the signal path compensation feature (SPC), you optimize the oscilloscope capability to make accurate measurements based on the ambient temperature.

You *must* run an SPC anytime you wish to ensure that the measurements you make are made with the most accuracy possible. You should also run an SPC if the temperature has changed more than 5° C since the last SPC was performed.

- f. *Run the signal path compensation:* Disconnect all input signals. Press the main-menu button **Signal Path**; then press the side-menu button **OK Compensate Signal Paths**.

NOTE. *Failure to run the signal path compensation may result in the oscilloscope not meeting warranted performance levels.*



- g. *Wait:* signal path compensation runs in one to three minutes. While it progresses, a “clock” icon (shown at left) displays on screen. When compensation completes, the status message updates to *Pass* or *Fail* in the main menu (see step h).
 - h. *Confirm signal path compensation returns passed status:* Verify the word **Pass** appears under **Signal Path** in the main menu. (See Figure 4-2.)
2. *Return to regular service:* Press **CLEAR MENU** to exit the system menus.

Functional Tests

The purpose of these procedures is to confirm that this oscilloscope functions properly. The only equipment required is one of the standard-accessory probes and a 3.5", 720 K or 1.44 Mbyte floppy disk.

STOP. These procedures verify functions; that is, they verify that oscilloscope features operate. They do not verify that they operate within limits. Therefore, when the instructions in the functional tests that follow call for you to verify that a signal appears on screen “that is about five divisions in amplitude” or “has a period of about six horizontal divisions,” and so forth, do **NOT** interpret the quantities given as limits. Operation within limits is checked in Performance Tests, which begin on page 4-15.

DO NOT make changes to the front-panel settings that are not called out in the procedures. Each verification procedure requires you to set the oscilloscope to certain default settings before verifying functions. If you make changes to these settings, other than those called out in the procedure, you may obtain invalid results. In this case, just redo the procedure from step 1.

When you are instructed to press a menu button, the button may already be selected (its label will be highlighted). If this is the case, it is not necessary to press the button.

Verify All Input Channels

Equipment Required	One P6138A probe
Prerequisites	None

1. Install the test hookup and preset the oscilloscope controls:

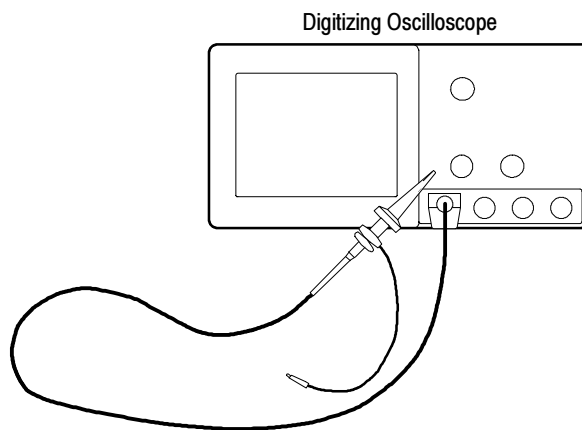

Figure 4-3: Universal Test Hookup for Functional Tests

- a. *Hook up the signal source:* Install the probe on **CH 1**. Connect the probe tip to **PROBE ADJ** on the front panel; leave the probe ground unconnected.

- b. Initialize the oscilloscope:*
 - Press save/recall **SETUP**.
 - Press the main-menu button **Recall Factory Setup**.
 - Press the side-menu button **OK Confirm Factory Init**.
 - 2. Verify that all input channels operate:* Do the following substeps — test CH 1 first, *skipping substep a since CH 1 is already set up for verification from step 1.*
 - a. Select an unverified channel:*
 - Press **WAVEFORM OFF** to remove from display the channel just verified.
 - Press the front-panel button that corresponds to the channel you are to verify.
 - Move the probe to the channel you selected.
 - b. Set up the selected channel:*
 - Press **AUTOSET** to obtain a viewable, triggered display in the selected channel.
 - Set the vertical **SCALE** to 100 mV. Use the vertical **POSITION** knob to center the waveform vertically on screen.
 - Set the horizontal **SCALE** to 200 μ s.
 - Press **TRIGGER MENU**.
 - Press the main-menu button **Coupling**; then press the side menu-button **HF Rej**.
 - c. Verify that the channel is operational:* Confirm that the following statements are true.
 - The vertical scale readout for the channel under test shows a setting of 100 mV, and a square-wave probe-compensation signal about five divisions in amplitude is on screen. (See Figure 4-1 on page 4-3 to locate the readout.)
 - The vertical **POSITION** knob moves the signal up and down the screen when rotated.
 - Turning the vertical **SCALE** knob counterclockwise decreases the amplitude of the waveform on-screen, turning the knob clockwise increases the amplitude, and returning the knob to 100 mV returns the amplitude to about five divisions.

- d. *Verify that the channel acquires in all acquisition modes:* Press **SHIFT**; then press **ACQUIRE MENU**. Use the side menu to select, in turn, each of the five hardware acquire modes and confirm that the following statements are true. Refer to the icons at the left of each statement as you confirm those statements.



- **Sample** mode displays an actively acquiring waveform on screen. (Note that there is noise present on the peaks of the square wave.)



- **Peak Detect** mode displays an actively acquiring waveform on screen with the noise present in Sample mode “peak detected.”



- **Hi Res** mode displays an actively acquiring waveform on screen with the noise that was present in Sample mode reduced.



- **Envelope** mode displays an actively acquiring waveform on screen with the noise displayed.



- **Average** mode displays an actively acquiring waveform on screen with the noise reduced like in Hi Res mode.

- e. *Test all channels:* Repeat substeps a through d until all input channels are verified.

3. *Remove the test hookup:* Disconnect the probe from the channel input and the probe-adjust terminal.

Verify the Time Base

Equipment Required	One P6138A probe
Prerequisites	None

1. *Install the test hookup and preset the oscilloscope controls:*
- a. *Hook up the signal source:* Install the probe on **CH 1**. Connect the probe tip to **PROBE ADJ** on the front panel; leave the probe ground unconnected. (See Figure 4-3 on page 4-8.)
 - b. *Initialize the oscilloscope:*
 - Press save/recall **SETUP**.
 - Press the main-menu button **Recall Factory Setup**; then press the side-menu button **OK Confirm Factory Init**.
 - c. *Modify default settings:*
 - Press **AUTOSET** to obtain a viewable, triggered display.
 - Set the horizontal **SCALE** to 200 μ s.

- Press **VERTICAL MENU**.
 - Press the main-menu button **Bandwidth**. Then press the side-menu button **20 MHz**.
 - Press **CLEAR MENU** to remove the vertical menu from the screen.
2. *Verify that the time base operates:* Confirm the following statements.
 - a. One period of the square-wave probe-compensation signal is about five horizontal divisions on-screen for the 200 μ s horizontal scale setting (set in step 1c).
 - b. Rotating the horizontal **SCALE** knob clockwise expands the waveform on-screen (more horizontal divisions per waveform period), counter-clockwise rotation contracts it, and returning the horizontal scale to 200 μ s returns the period to about five divisions.
 - c. The horizontal **POSITION** knob positions the signal left and right on screen when rotated.
 3. *Remove the test hookup:* Disconnect the probe from the channel input and the probe-adjust terminal.

Verify the Main and Delayed Trigger Systems

Equipment Required	One P6138A probe
Prerequisites	None

1. *Install the test hookup and preset the oscilloscope controls:*
 - a. *Hook up the signal source:* Install the probe on **CH 1**. Connect the probe tip to **PROBE ADJ** on the front panel; leave the probe ground unconnected. (See Figure 4-3 on page 4-8.)
 - b. *Initialize the oscilloscope:*
 - Press save/recall **SETUP**.
 - Press the main-menu button **Recall Factory Setup**.
 - Press the side-menu button **OK Confirm Factory Init**.
 - c. *Modify default settings:*
 - Press **AUTOSET** to obtain a viewable, triggered display.
 - Set the horizontal **SCALE** for the **M** (main) time base to 200 μ s.
 - Press **VERTICAL MENU**.

- Press the main-menu button **Bandwidth**; then press the side-menu button **20 MHz**.
 - Press **TRIGGER MENU**.
 - Press the main-menu button **Mode & Holdoff**.
 - Press the side-menu button **Normal**.
 - Press **CLEAR MENU** to remove the menus from the screen.
2. *Verify that the main trigger system operates:* Confirm that the following statements are true.
- The trigger-level readout for the main trigger system changes when you rotate the trigger **MAIN LEVEL** knob.
 - The trigger-level knob can trigger and untrigger the square-wave signal as you rotate it. (Leave the signal *untriggered*.)
 - Pressing **SET LEVEL TO 50%** triggers the signal that you just left untriggered. (Leave the signal triggered.)
3. *Verify that the delayed trigger system operates:*
- a. *Select the delayed time base:*
- Press **HORIZONTAL MENU**.
 - Press the main-menu button **Time Base**.
 - Press the side-menu button **Delayed Triggerable**; then press the side-menu button **Delayed Only**.
 - Set the horizontal **SCALE** for the **D** (delayed) time base to 200 μ s.
- b. *Select the delayed trigger-level menu:*
- Press **SHIFT**; then press **DELAYED TRIG**.
 - Press the main-menu button **Level**; then press the side-menu button **Level**.
- c. *Confirm that the following statements are true:*
- The trigger-level readout for the delayed trigger system changes when you rotate the general purpose knob.
 - The general purpose knob can trigger and untrigger the square-wave probe-compensation signal as you rotate it. (Leave the signal *untriggered*.)

- Pressing the side-menu button **Set to 50%** triggers the probe-compensation signal that you just left untriggered. (Leave the signal triggered.)
 - d. *Verify the delayed trigger counter:*
 - Press the main-menu button **Delay by Time**.
 - Press the side-menu button **Events**, just below the **Triggerable after Time** selection.
 - Use the General Purpose knob to enter an event count of 325 events.
 - Verify that the trigger **READY** indicator on the front panel flashes about once every second as the waveform is updated on screen.
- 4. *Remove the test hookup:* Disconnect the standard-accessory probe from the channel input and the probe-adjust terminal.

Verify the File System

Equipment Required	One 720 K or 1.44 Mbyte, 3.5 inch DOS compatible disk (formatted).
Prerequisites	None

1. *Preset the digitizing oscilloscope controls:*
 - a. Insert the disk in the disk drive.
 - b. Press save/recall **SETUP**. Press the main menu button **Recall Factory Setup**; then press the side menu button **Ok Confirm Factory Init**.
 - c. Set the horizontal **SCALE** to 200 μ s (one click clockwise). Notice the horizontal readout now displays 200 μ s at the bottom of the screen.
2. *Verify the file system works:*
 - a. Press save/recall **SETUP**. Press the main menu button **Save Current Setup**; then press the side menu button **To File**.
 - b. Turn the general purpose knob to select the file to save. Choose **TEK?????.SET**. With this choice, you will save a file starting with **TEK**, then containing five digits, and a **.SET** extension. For example, the first time you run this on a blank, formatted disk or on the Example Programs Disk, the digitizing oscilloscope will assign the name **TEK00000.SET** to your file. If you ran the procedure again, the digitizing oscilloscope would increment the name and call the file **TEK00001.SET**.
 - c. Press the side-menu button **Save To Selected File**.

- d. Set the horizontal **SCALE** to 500 μ s, and then use the vertical **POSITION** knob to place the channel 1 baseline trace two divisions above center screen.
 - e. Press the main menu button **Recall Saved Setup**; then press the side menu button **From File**.
 - f. Turn the general purpose knob to select the file to recall. For example, if you followed the instructions above and used a blank disk, you had the digitizing oscilloscope assign the name **TEK00000.SET** to your file.
 - g. Press the side-menu button **Recall From Selected File**.
 - h. Verify that the digitizing oscilloscope retrieved the saved setup from the disk. Do this by noting that the horizontal **SCALE** again reads 200 μ s and the channel 1 baseline waveform is again vertically positioned near center screens as when you saved the setup.
3. *Remove the test hookup:* Remove the disk from the disk drive.

Performance Tests

This section contains procedures for checking that the TDS 400A Digitizing Oscilloscopes perform as warranted.

The procedures are arranged in four logical groupings: *Signal Acquisition System Checks*, *Time Base System Checks*, *Triggering System Checks*, and *Output Ports Checks*. They check all the characteristics that are designated as checked in Chapter 1, *Specifications*. (The characteristics that are checked appear in **boldface** type under *Warranted Characteristics* in Chapter 1.) You can use the form at the end of this section as a test record.

The procedures are arranged in four logical groupings: *Signal Acquisition System Checks*, *Time Base System Checks*, *Triggering System Checks*, and *Output Ports Checks*. They check all the characteristics that are designated as checked in Chapter 1, *Specifications*. (The characteristics that are checked appear in **boldface** type under *Warranted Characteristics* in Chapter 1.) You can use the form at the end of this section as a test record.

Read *Performance Verification Procedures* that start on page NO TAG. Also, if you are not familiar with operating this digitizing oscilloscope, read *Operating Information* in Chapter 2 of the service manual or read the user manual before doing any of these procedures.

STOP. *These procedures extend the confidence level provided by the basic procedures described on page 4-5. The basic procedures should be done first, and then these procedures performed if desired.*

Prerequisites

The tests in this chapter comprise an extensive, valid confirmation of performance and functionality when the following requirements are met:

- The cabinet must be installed on the digitizing oscilloscope.
- You must have performed and passed the procedures under *Self Tests*, found on page 4-5, and those under *Functional Tests*, found on page 4-7.
- A signal-path compensation *must* have been done within the recommended calibration interval and at a temperature within $\pm 5^{\circ}$ C of the present operating temperature. (If at the time you did the prerequisite *Self Tests*, the temperature was within the limits just stated, consider this prerequisite met.)

- The digitizing oscilloscope must have been last adjusted at an ambient temperature between +20° C and +30° C, must have been operating for a warm-up period of at least 20 minutes, and must be operating at an ambient temperature between 5° C and +40° C. (The warm-up requirement is usually met in the course of meeting the prerequisites listed above.)

Equipment Required

These procedures use external, traceable signal sources to directly check warranted characteristics. The test equipment required is shown in Table 4-1.

Table 4-1: Test Equipment

Item Number and Description	Minimum Requirements	Example	Purpose
1. Attenuator, 10X (three required)	Ratio: 10X; impedance 50 Ω ; connectors: female BNC input, male BNC output	Tektronix part number 011-0059-02	Signal Attenuation
2. Attenuator, 5X (two required)	Ratio: 5X; impedance 50 Ω ; connectors: female BNC input, male BNC output	Tektronix part number 011-0060-02	Signal Attenuation
3. Termination, 50 Ω	Impedance 50 Ω ; connectors: female BNC input, male BNC output	Tektronix part number 011-0049-01	Checking delay match between channels
4. Termination, 75 Ω	Impedance 75 Ω ; connectors: female BNC input, male BNC output	Tektronix part number 011-0102-01	Used to test Video Option 05 equipped oscilloscopes only
5. Cable, Precision Coaxial (three required)	50 Ω , 36 in, male to male BNC connectors	Tektronix part number 012-0482-00	Signal Interconnection
6. Cable, Coaxial	75 Ω , 36 in, male to male BNC connectors	Tektronix part number 012-1338-00	Used to test Video Option 05 equipped oscilloscopes only
7. Connector, Dual-Banana (two required)	Female BNC to dual banana	Tektronix part number 103-0090-00	Various Accuracy Tests
8. Connector, BNC "T"	Male BNC to dual female BNC	Tektronix part number 103-0030-00	Checking Trigger Sensitivity
9. Coupler, Dual-Input	Female BNC to dual male BNC	Tektronix part number 067-0525-02	Checking Delay Match Between Channels
10. Generator, DC Calibration	Variable amplitude to ± 110 V; accuracy to 0.1%	Wavetek 9100 (or, optionally, Data Precision 8200, with 1 kV option installed)	Checking DC Offset and Measurement Accuracy
11. Generator, Sine Wave	100 kHz to at least 400 MHz. Variable amplitude from 12 mV to 2 V _{p-p} . Frequency accuracy >2.0%	Rohde & Schwarz SMY ¹	Checking Analog Bandwidth, Trigger Sensitivity, Sample-rate, External Clock, and Delay-Time Accuracy
12. Meter, Level and Power Sensor	Frequency range: 10 MHz to 400 MHz. Amplitude range: 6 mV _{p-p} to 2 V _{p-p}	Rohde & Schwarz URV 35, with NRW-Z8 power sensor	Checking Analog Bandwidth and Trigger Sensitivity

Table 4-1: Test Equipment (Cont.)

Item Number and Description	Minimum Requirements	Example	Purpose
13. Splitter, Power	Frequency range: DC to 1 GHz. Tracking: >2.0%	Rohde & Schwarz RVZ	Checking Analog Bandwidth
14. Generator, Function	Frequency range 5 MHz to 10 MHz. Square wave transition time ≤ 25 ns. Amplitude range: 0 to 10 V_{p-p} into 50 Ω	Tektronix CFG280	Checking External Clock
15. Adapter (four required)	Male N to female BNC	Tektronix 103-0045-00	Checking Analog Bandwidth
16. Adapter	Female N to male BNC	Tektronix 103-0058-00	Checking Analog Bandwidth
17. Probe, 10X included with this oscilloscope	A P6138A probe	Tektronix P6138A	Signal Interconnection
18. Generator, Video Signal	Provides NTSC compatible outputs	Tektronix TSG 1001	Checking Video Trigger Sensitivity

¹ If available, items 11, 12, 13, and 15 can be replaced by a Tektronix SG 503 and SG 504. If available, a TG 501A may be used to check Sample-rate and Delay-time Accuracy. (A TM 500 or TM 5000 Series Power Module Mainframe is required.) If using a TG 501A, you may also need a 2X attenuator (50 Ω BNC), Tektronix part number 011-0069-02.

Test Record

Photocopy this page and the next page and use them to record the performance test results for your oscilloscope.

TDS 400A Test Record

Oscilloscope Serial Number: _____	Certificate Number: _____
Temperature: _____	RH %: _____
Date of Calibration: _____	Technician: _____

Performance Test	Minimum	Incoming	Outgoing	Maximum
Offset Accuracy				
CH1 Offset	+1 V	995 mV	_____	+ 1.005 V
	+10 V	9.935 V	_____	+ 10.065 V
	+99.9 V	99.2505 V	_____	+ 100.5495 V
CH2 Offset	+1 V	995 mV	_____	+ 1.005 V
	+10 V	9.935 V	_____	+ 10.065 V
	+99.9 V	99.2505 V	_____	+ 100.5495 V
CH3 Offset (TDS 420A & TDS 460A)	+1 V	995 mV	_____	+ 1.005 V
	+10 V	9.935 V	_____	+ 10.065 V
	+99.9 V	99.2505 V	_____	+ 100.5495 V
CH4 Offset (TDS 420A & TDS 460A)	+1 V	995 mV	_____	+ 1.005 V
	+10 V	9.935 V	_____	+ 10.065 V
	+99.9 V	99.2505 V	_____	+ 100.5495 V
DC Voltage Measurement Accuracy (Averaged)				
CH1 100 mV	-20.8 mV	_____	_____	+20.8 mV
CH2 100 mV	-20.8 mV	_____	_____	+20.8 mV
CH3 100 mV (TDS 420A and TDS 460A)	-20.8 mV	_____	_____	+20.8 mV
CH4 100 mV (TDS 420A and TDS 460A)	-20.8 mV	_____	_____	+20.8 mV
Analog Bandwidth				
CH1 100 mV	424 mV	_____	_____	N/A
CH2 100 mV	424 mV	_____	_____	N/A
CH3 100 mV (TDS 420A and TDS 460A)	424 mV	_____	_____	N/A
CH4 100 mV (TDS 420A and TDS 460A)	424 mV	_____	_____	N/A
Time Base System				
Delay Between Channels	N/A	_____	_____	450 ps
Delta Time @ 20 ns (100 MHz)	9.7 ns	_____	_____	10.3 ns
Long Term Sample Rate/ Delay Time @ 10 ns/100 μ s	-1.5 Div	_____	_____	+1.5 Div

TDS 400A Test Record (Cont.)

Oscilloscope Serial Number: _____ Certificate Number: _____
 Temperature: _____ RH %: _____
 Date of Calibration: _____ Technician: _____

Performance Test	Minimum	Incoming	Outgoing	Maximum
Trigger System (DC Coupled Threshold)				
Main Trigger	-18 mV	_____	_____	+18 mV
Main Trigger — Falling	-18 mV	_____	_____	+18 mV
Main Trigger Delayed Trigger — Falling	-18 mV -18 mV	_____	_____	+18 mV +18 mV
Auxiliary Trigger		_____	_____	10 MHz
External Clock		_____	_____	10 MHz
Probe Compensator Output Signal				
Frequency	950 Hz	_____	_____	1050 Hz
Voltage	475 mV	_____	_____	525 mV

Signal Acquisition System Checks

These procedures check those characteristics that relate to the signal-acquisition system and are listed as checked under *Warranted Characteristics* in Chapter 1, *Specification*.

Check Offset Accuracy

Equipment Required	Two dual-banana connectors (Item 7) One BNC T connector (Item 8) One DC calibration generator (Item 10) Two precision coaxial cables (Item 5)
Prerequisites	See page 4-15.

1. *Install the test hookup and preset the instrument controls:*

a. *Hook up the test-signal source:*

- Set the output of a DC calibration generator to 0 volts.
- Connect the output of a DC calibration generator through a dual-banana connector followed by a 50 Ω precision coaxial cable to one side of a BNC T connector (see Figure 4-4).
- Connect the Sense output of the generator through a second dual-banana connector followed by a 50 Ω precision coaxial cable to the other side of the BNC T connector. Now connect the BNC T connector to **CH 1**.

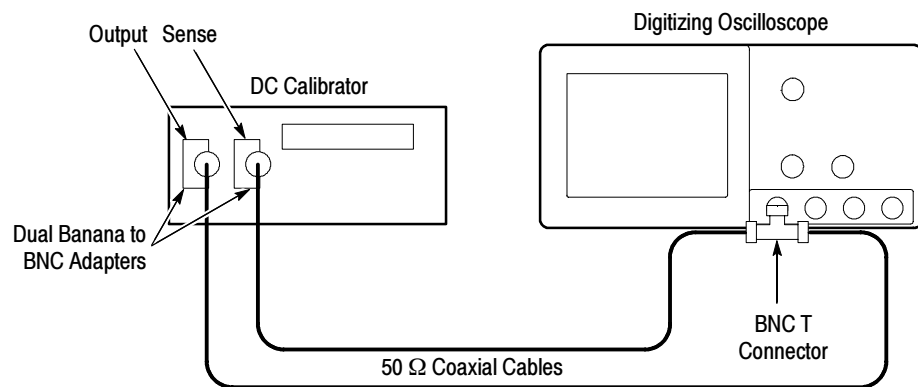

Figure 4-4: Initial Test Hookup

- b. *Initialize the oscilloscope:*
 - Press save/recall **SETUP**.
 - Press the main-menu button **Recall Factory Setup**.
 - Press the side-menu button **OK Confirm Factory Init**.
 - c. *Modify the default settings:*
 - Set the horizontal **SCALE** to 1 ms.
 - Press **SHIFT**; then **ACQUIRE MENU**.
 - Press the main-menu button **Mode**; then press the side-menu button **Hi Res**.
 - Press **DISPLAY**.
 - Press the main-menu button **Graticule**; then press the side-menu button **Frame**.
 - Press **MEASURE**.
 - Press the main-menu button **Select Measurement for CHx**; then press the side-menu button **Mean**. (You will have to press **MORE** several times to access the **Mean** measurement.)
 - Press **CLEAR MENU**.
2. *Confirm input channels are within limits for offset accuracy: Do the following substeps — test CH 1 first, skipping substep a since CH 1 is already set up to be checked from step 1.*



WARNING. *High voltages are used in this procedure. Before doing this or any other procedure in this manual, read the Safety Summary found at the beginning of this manual.*

- a. *Select an unchecked channel:*
 - Press **WAVEFORM OFF** to remove the channel just confirmed from the display. Then, press the front-panel button that corresponds to the channel you are to confirm.
 - Press **MEASURE**.
 - Press the main-menu button **Select Measurement for CHx**; then press the side-menu button **Mean**. (You will have to press **MORE** several times to access the **Mean** measurement.)

Table 4-2: DC Offset Accuracy

Vertical Scale Setting	Vertical Position	Offset Setting	Generator Setting	Offset Accuracy Limits
1 mV	0	+1 V	+1 V	±5 mV
100 mV	0	+10 V	+10 V	±65 mV
1 V	0	+99.9 V	+99.9 V	±649.5 mV

- b. *Set the vertical scale:* Set the vertical **SCALE** to one of the settings listed in Table 4-2 that is not yet checked. (Start with the first setting listed.)
 - c. *Set the offset:* Press the **VERTICAL MENU** button and then the **Offset** main-menu button. Using the **General Purpose** knob, set the offset as dictated by Table 4-2. (Start with the first setting listed.)
 - d. *Set the generator:* Set the DC calibration generator to match the vertical scale as dictated by Table 4-2. (Start with the first setting listed.)
 - e. *Check against limits:* Do the following subparts in the order listed.
 - Subtract the measured mean from the generator setting. The result is the offset accuracy
 - **CHECK** that the offset accuracy is within the limits listed for the current vertical scale setting.
 - Repeat substeps b through e until all vertical scale settings listed in Table 4-2 are checked for the channel under test.
 - f. *Test all channels:* Repeat substeps a through e for all input channels.
3. *Disconnect the hookup:*
- a. *Set the generator output to 0 V.*
 - b. Then disconnect the cable from the generator output at the input connector of the channel last tested.

Check DC Voltage Measurement Accuracy (Averaged)

Equipment Required	Two dual-banana connectors (Item 7) One BNC T connector (Item 8) One DC calibration generator (Item 10) Two precision coaxial cables (Item 5)
Prerequisites	See page 4-15.

1. *Install the test hookup and preset the instrument controls:*

a. *Hook up the test-signal source:*

- Set the output of a DC calibration generator to 0 volts.
- Connect the output of a DC calibration generator through a dual-banana connector followed by a 50 Ω precision coaxial cable to one side of a BNC T connector (see Figure 4-5).
- Connect the Sense output of the generator through a second dual-banana connector followed by a 50 Ω precision coaxial cable to the other side of the BNC T connector. Now connect the BNC T connector to **CH 1**.

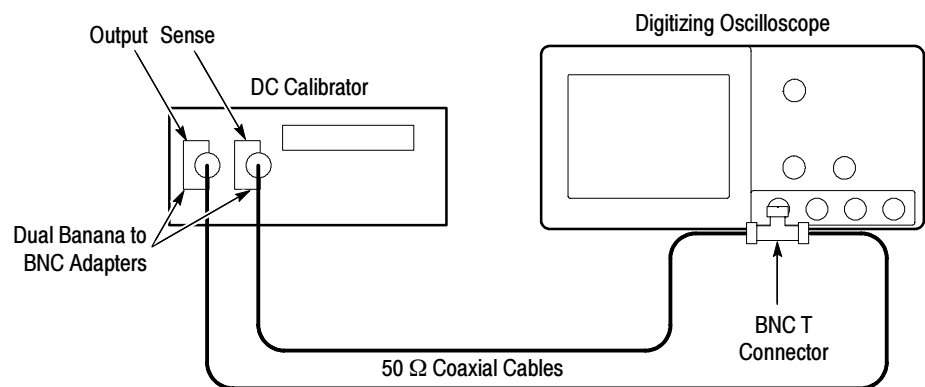

Figure 4-5: Initial Test Hookup

b. *Initialize the oscilloscope:*

- Press save/recall **SETUP**.
- Press the main-menu button **Recall Factory Setup**.
- Press the side-menu button **OK Confirm Factory Init**.

c. *Modify the default settings:*

- Press **SHIFT** and then **ACQUIRE MENU**.
- Press the main-menu button **Mode**; then press the side-menu button **Average 16**.
- Press **DISPLAY**.
- Press the main-menu button **Graticule**; then press the side-menu button **Frame**.

- Press **MEASURE**.
 - Press the main-menu button **Select Measurement for CHx**; then press the side-menu button **Mean**. (You will have to press **MORE** several times to access the **Mean** measurement.)
 - Set the vertical **SCALE** to 100 mV.
 - Press the **VERTICAL MENU** button and then the **Offset** main-menu button. Set the offset to 0 V.
 - Set the vertical **POSITION** to 0 V.
2. *Confirm input channels are within limits for DC delta voltage accuracy: Do the following substeps — test CH 1 first, skipping substep a since CH 1 is already selected from step 1.*
- a. *Select an unchecked channel:*
 - *Set the generator output to 0 V.*
 - Press **WAVEFORM OFF** to remove the channel just confirmed from the display.
 - Press the front-panel button that corresponds to the next channel you are to confirm.
 - Press **MEASURE**.
 - Press the main-menu button **Select Measurement for CHx**; then press the side-menu button **Mean**. (You will have to press **MORE** several times to access the **Mean** measurement.)
 - Move the test hook up to the channel you select.
 - Set the vertical **SCALE** to 100 mV.
 - Set the vertical **POSITION** to 0 V.
 - Press the **VERTICAL MENU** button and then the **Offset** main-menu button. Set the offset to 0 V.
 - b. *Set the generator:* Set the DC calibration generator to +0.35 V.
 - c. *Record Measurement:* Read the mean at the measurement readout, and record this number on a piece of scratch paper.
 - d. *Set the generator:* Set the DC calibration generator to -0.35 V.

e. *Check against limits:* Do the following subparts in the order listed.

- Use this formula to calculate voltage measurement accuracy.

$$700 \text{ mV} - (\text{mean from step c} - (\text{present mean}))$$

For example:

$$700 \text{ mV} - (347 \text{ mV} - (-358 \text{ mV})) = -5 \text{ mV}$$

- CHECK that the voltage measurement accuracy is within $\pm 20.8 \text{ mV}$.

f. *Test all channels:* Repeat substeps a through e for all channels.

3. *Disconnect the hookup:*

- a. *Set the generator output to 0 V.*
- b. Then disconnect the cable from the generator output at the input connector of the channel last tested.

Check Analog Bandwidth

Equipment Required	One sine wave generator (Item 11) One level meter and power sensor (Item 12) One power splitter (Item 13) One Female N to Male BNC Adapter (Item 16) Four Male N to Female BNC Adapters (Item 15) Two 50 Ω precision cables (Item 5) Two 10X attenuators (Item 1).
Prerequisites	See page 4-15.

1. *Install the test hookup and preset the instrument controls:*

a. *Initialize the oscilloscope:*

- Press save/recall **SETUP**. Then press the main-menu button **Recall Factory Setup**.
- Press the side-menu button **OK Confirm Factory Init**.

b. *Modify the default settings:*

- Press **TRIGGER MENU**.
- Press the main-menu button **COUPLING**; then press the side menu button **Noise Rej**.

- Press **SHIFT**; then **ACQUIRE MENU**.
- Press the main-menu button **Mode**; then press the side-menu button **Average 16**.
- Press **Measure**. Now press the main-menu button **High-Low Setup**; then press the side-menu button **Min-Max**.

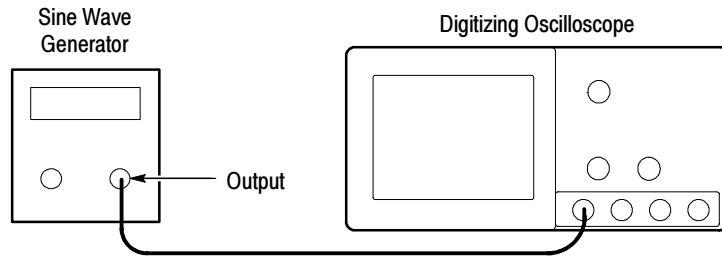

Figure 4-6: Initial Test Hookup

NOTE. Refer to the Sine Wave Generator Leveling Procedure on page 4-55 if your sine wave generator does not have automatic output amplitude leveling.

- c. Hook up the test-signal source:
 - Connect the sine wave output of a sine wave generator to **CH 1** (see Figure 4-6). Set the output of the generator to a reference frequency of 10 MHz or less.
 - Set the horizontal **SCALE** to 50 ns. (If using a reference other than 10 MHz, adjust the horizontal **SCALE** to display 4 to 6 cycles of the waveform.)
2. Confirm the input channels are within limits for analog bandwidth: Do the following substeps — test CH 1 first, skipping substeps a and b since CH 1 is already set up for testing from step 1.
 - a. Select an unchecked channel:
 - Press **WAVEFORM OFF** to remove the channel just confirmed from display.
 - Press the front-panel button that corresponds to the channel you are to confirm.
 - Move the leveled output of the sine wave generator to the channel you select.

- b. *Match the trigger source to the channel selected:*
- Press **TRIGGER MENU**.
 - Press the main-menu button **Source**.
 - Press the side-menu button that corresponds to the channel selected.
- c. *Set the input impedance of the channel:*
- Press **VERTICAL MENU**; then press the main-menu button **Coupling**.
 - Press the side-menu button **Ω** to toggle it to the 50 Ω setting.
- d. *Set the vertical scale:* Set the vertical **SCALE** to one of the settings listed in Table 4-3 (TDS 420A) or Table 4-4 (TDS 430A and TDS 460A) not yet checked. (Start with the 100 mV setting.)

Table 4-3: Analog Bandwidth (TDS 420A)

Vertical Scale	Reference Amplitude	Horizontal Scale	Test Frequency	Limits
100 mV	600 mV (6 divisions)	5 ns	200 MHz	≥424 mV
1 V ⁴	2 V (2 divisions)	5 ns	200 MHz	≥1.414 V
500 mV	2 V (4 divisions)	5 ns	200 MHz	≥1.414 V
200 mV	1.2 V (6 divisions)	5 ns	200 MHz	≥848 mV
50 mV	300 mV (6 divisions)	5 ns	200 MHz	≥212 mV
20 mV	120 mV (6 divisions)	5 ns	200 MHz	≥84 mV
10 mV	60 mV (6 divisions)	5 ns	200 MHz	≥42 mV
5 mV	30 mV (6 divisions)	5 ns	200 MHz	≥21 mV
2 mV	12 mV (6 divisions)	5 ns	150 MHz	≥8.4 mV
1 mV	6 mV (6 divisions)	5 ns	95 MHz	≥4.2 mV

⁴ If the oscilloscope does not trigger in step 2e, change the trigger coupling to DC for this Vertical Scale setting.

Table 4-4: Analog Bandwidth (TDS 430A and TDS 460A)

Vertical Scale	Reference Amplitude	Horizontal Scale	Test Frequency	Limits
100 mV	600 mV (6 divisions)	2 ns	400 MHz	≥424 mV
1 V ⁴	2 V (2 divisions)	2 ns	400 MHz	≥1.414 V
500 mV	2 V (4 divisions)	2 ns	400 MHz	≥1.414 V
200 mV	1.2 V (6 divisions)	2 ns	400 MHz	≥848 mV
50 mV	300 mV (6 divisions)	2 ns	400 MHz	≥212 mV
20 mV	120 mV (6 divisions)	2 ns	400 MHz	≥84 mV
10 mV	60 mV (6 divisions)	2 ns	400 MHz	≥42 mV
5 mV	30 mV (6 divisions)	2 ns	400 MHz	≥21 mV
2 mV	12 mV (6 divisions)	2 ns	250 MHz	≥8.4 mV
1 mV	6 mV (6 divisions)	2 ns	100 MHz	≥4.2 mV

⁴ If the oscilloscope does not trigger in step 2e, change the trigger coupling to DC for this Vertical Scale setting.

- e. *Display the test signal:* Do the following subparts to first display the reference signal and then the test signal.
- Press **MEASURE**; then press the main-menu button **Select Measurement for CHx**.
 - Now press the side menu button **more** until the menu label **Pk-Pk** appears in the side menu (its icon is shown at the left). Press the side-menu button **Pk-Pk**.
 - Press **CLEAR MENU**.
 - Set the sine wave generator output (if necessary, use 10X attenuators) so the CHx Pk-Pk readout equals the reference amplitude in Table 4-3 (TDS 420A) or Table 4-4 (TDS 430A and TDS 460A) that corresponds to the vertical scale set in substep d.
 - Press the front-panel button **SET LEVEL TO 50%** as necessary to trigger a stable display.
- f. *Measure the test signal:*
- Increase the frequency of the generator output (leveled output) to the test frequency in Table 4-3 (TDS 420A) or Table 4-4 (TDS 430A and TDS 460A) that corresponds to the vertical scale set in substep d.
 - Set the horizontal **SCALE** to 5 ns (TDS 420A) or 2 ns (TDS 430A and TDS 460A).
 - Press **SET LEVEL TO 50%** as necessary to trigger the display.



- Read the results at the CHx Pk-Pk readout, which automatically measures the amplitude of the test signal. (See Figure 4-7.)

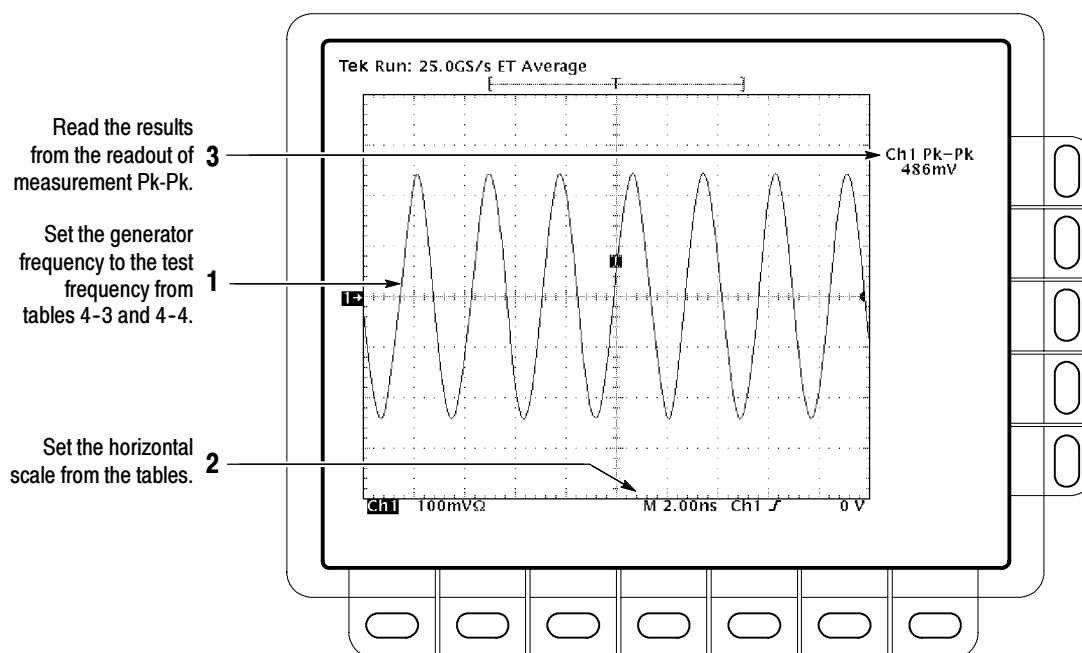

Figure 4-7: Measurement of Analog Bandwidth

g. Check against limits:

- CHECK that the **Pk-Pk** readout on screen is within the limits listed in Table 4-3 (TDS 420A) or Table 4-4 (TDS 430A and TDS 460A) for the current vertical scale setting.
- When finished checking, set the horizontal **SCALE** back to the 50 ns setting (the setting you used in step 1b).

STOP. Checking the bandwidth of each channel at all vertical scale settings is time consuming and unnecessary. You may skip checking the remaining vertical scale settings in Table 4-3 (TDS 420A) or Table 4-4 (TDS 430A and TDS 460A) (that is, skip the following substep, h) if this digitizing oscilloscope has passed the 100 mV vertical scale setting just checked in this procedure and passed the Verify Internal Adjustment, Self Compensation, and Diagnostics procedure found under Self Tests, on page 4-5.

NOTE. *Passing the signal path compensation confirms the signal path for all vertical scale settings for all channels. Passing the internal diagnostics ensures that the factory-set adjustment constants that control the bandwidth for each vertical scale setting have not changed.*

- h. *Check remaining vertical scale settings against limits (optional):*
 - If desired, finish checking the remaining vertical scale settings for the channel under test by repeating substeps d through g for each of the remaining scale settings listed in Table 4-3 (TDS 420A) or Table 4-4 (TDS 430A and TDS 460A) for the channel under test.
 - When doing substep e, skip the subparts that turn on the CHx Pk-Pk measurement until you check a new channel.
 - Install/remove 10X attenuators between the generator leveled output and the channel input as is needed to obtain the six division reference signals listed in the tables.
 - i. *Test all channels:* Repeat substeps a through g for all channels.
3. *Disconnect the hookup:* Disconnect the test hook up from the input connector of the channel last tested.

Check Delay Match Between Channels

Equipment Required	One sine wave generator (Item 11) One precision coaxial cable (Item 5) One 50 Ω terminator (Item 3) One dual-input coupler (Item 9)
Prerequisites	See page 4-15.

STOP. *DO NOT use the vertical position knob to reposition any channel while doing this check. To do so invalidates the test.*

- 1. *Install the test hookup and preset the oscilloscope controls:*
 - a. *Initialize the front panel:*
 - Press save/recall **SETUP**.
 - Press the main-menu button **Recall Factory Setup**.
 - Press the side-menu button **OK Confirm Factory Init**.

b. Modify the initialized front-panel control settings:

- Do *not* adjust the vertical position of any channel during this procedure.
- Set the horizontal **SCALE** to 1 ns.
- Press **SHIFT**; then press **ACQUIRE MENU**.
- Press the main-menu button **Mode**, and then press the side-menu button **Average 16**.

c. Hook up the test-signal source:

- Connect the sine wave output of a sine wave generator to a 50 Ω precision coaxial cable, a 50 Ω termination, and a dual-input coupler. (See Figure 4-8.)
- Connect the coupler to both **CH 1** and **CH 2**. *Ensure that the coupler cables are of equal length.*

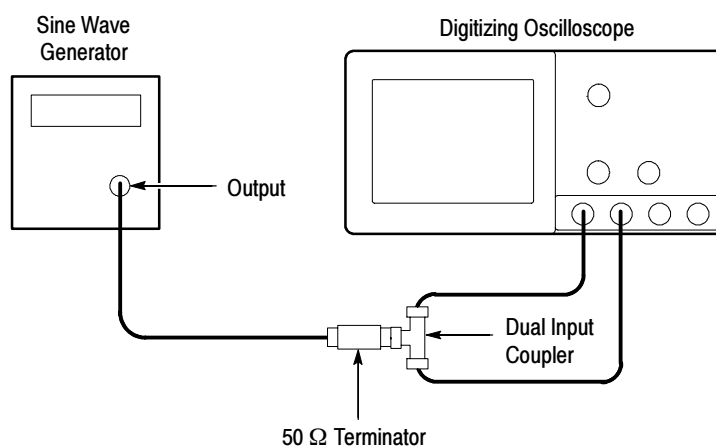

Figure 4-8: Initial Test Hookup

2. Confirm all channels are within limits for channel delay:

- a. Set up the generator:** Set the generator frequency to 250 MHz and the amplitude for about five divisions in CH 1.

Hint: as you are adjusting the generator amplitude, push **SET LEVEL TO 50%** frequently to speed up the updating of the waveform amplitude on screen.

- b. Save a CH 2 waveform:** Press **CH 2**; then press save/recall **WAVEFORM**. Now, press the main-menu button **Save Waveform**; then press the side-menu button **To Ref 2**.

- c. If you are testing a TDS 430A, skip to step h.
- d. *Save a CH 3 waveform:* Move the coupler from **CH 2** to **CH 3**, so that **CH 1** and **CH 3** are driven. Press **CH 3**; then press the side-menu button **To Ref 3**.
- e. *Display all test signals:*
 - Press **WAVEFORM OFF** twice to remove CH 2 and CH 3 from the display.
 - Move the coupler from **CH 3** to **CH 4**, so that CH 1 and CH 4 are driven. Press **CH 4** to display.
 - Now, press the front-panel button **MORE**. Press the main-menu buttons **Ref 2** and **Ref 3**.
- f. *Measure the test signal:*
 - Locate the point on the rising edge of the left-most waveform where it crosses the center horizontal graticule line. This is the *time reference point* for this waveform. Note the corresponding *time reference point* for the right-most waveform. See Figure 4-9.
 - Press **CURSOR**; then press the side-menu button **V Bars**.
 - Press **CLEAR MENU**.
 - Rotate the General Purpose knob to align one cursor to the *time reference point* of the left-most waveform edge and the other cursor to the *time reference point* of the right-most waveform edge. (Press **SELECT** to switch between the two cursors.) See Figure 4-9.
 - Read the measurement results at the **Δ:** cursor readout, not the **@:** readout on screen.
- g. *Check all channels against limit:* CHECK that the cursor readout on screen is ≤ 450 ps. If the cursor readout is ≤ 200 ps, skip substep h.

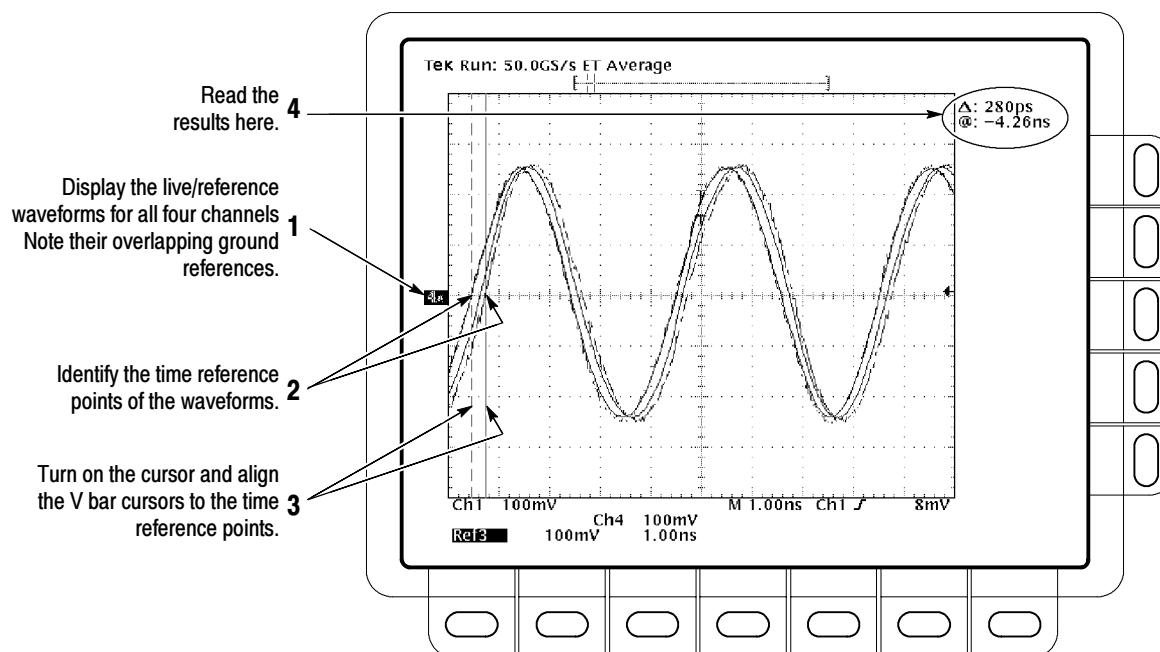

Figure 4-9: Measurement of Channel Delay

h. Check CH 1 to CH 2 and CH 3 to CH 4 against limit:

- Press **WAVEFORM OFF** four times to remove all waveforms.
- Press **CH 1**.
- Press **MORE**; then press the main-menu button **Ref 2**.
- Measure the delay between CH 1 and Ref 2 using the method described in substep f above.
- CHECK that the cursor readout on screen is ≤ 200 ps.
- If you are testing a TDS 430A, skip to step 3.
- Press **WAVEFORM OFF** twice to turn off CH 1 and Ref 2; then press **CH 4** to turn on CH 4.
- Press **MORE**; then press the main-menu button **Ref 3** to display the CH 3 waveform stored in Ref 3.
- Measure the delay between Ref 3 and CH 4 using the method described in substep f above.
- CHECK that the cursor readout on screen is ≤ 200 ps.

3. *Disconnect the hookup:* Disconnect the cable from the generator output at the input connectors of the channels.

Time Base System Checks

These procedures check those characteristics that relate to the Main and Delayed time base system and are listed as checked under *Warranted Characteristics* in Chapter 1, *Specification*.

Check Accuracy for Long-Term Sample Rate, Delay Time, and Delta Time Measurements

Equipment Required	One time standard, either a frequency accurate sine wave generator or time marker generator (Item 11) Attenuators, 10X and 5X (Items 1 and 2) One precision coaxial cable (Item 5).
Prerequisites	See page 4-15.

1. *Install the test hookup and preset the oscilloscope controls:*
 - a. *Hook up the test-signal source:* Connect, through a 50 Ω precision coaxial cable, the output of a time standard to **CH 1** (see Figure 4-10). Set the output of the standard to 100 MHz (or a period of 10 ns).

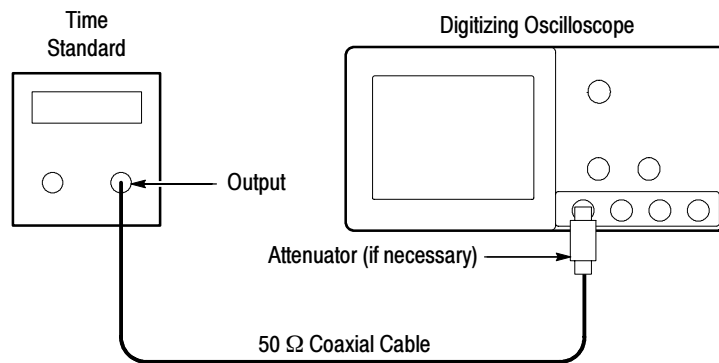

Figure 4- 10: Initial Test Hookup

- b. *Initialize the oscilloscope:*
 - Press save/recall **SETUP**.
 - Press the main-menu button **Recall Factory Setup**.
 - Press the side-menu button **OK Confirm Factory Init**.

- c. *Modify the initialized front-panel control settings:*
 - Press **VERTICAL MENU**; then press the main-menu button **Coupling**. Press the side-menu button Ω to change the coupling setting to **50 Ω** .
 - If necessary, set the vertical **SCALE** to 100 mV per division.
 - Set the horizontal **SCALE** of the Main time base to 2.0 ns.
 - Using external attenuators if necessary, adjust the time standard amplitude for a 5 to 7 division display.
 - Rotate the vertical **POSITION** control to center the displayed waveform.
2. *Confirm Main and Delayed time bases are within limits for accuracies:*
 - a. *Check delta-time accuracy against limits:*
 - Press **SET LEVEL TO 50%**.
 - Press **SHIFT**; then **ACQUIRE MENU**. Now press the main-menu button **Mode**; then press the side-menu button **Average**.
 - Use the **General Purpose** knob to set the number of averages to 8.
 - Press **MEASURE**.
 - Press the main-menu button **High-Low Setup**; then press the side-menu button **Min-Max**.
 - Press the main-menu button **Select Measurement for Ch1**.
 - Press the side-menu button **-more-**, until **PERIOD** appears in the side menu. Press **PERIOD**.
 - Press **CLEAR MENU**.
 - CHECK that the readout for **CH 1 Per** is within 9.7 ns to 10.3 ns.
 - b. *Check long-term sample rate and delay time accuracies against limits:*
 - Press **SHIFT**; then **ACQUIRE MENU**. Now press the main-menu button **Mode**; then press the side-menu button **Sample**.
 - Press **MEASURE**.
 - Press the main-menu button **Remove Measurement**; then press the side-menu button **Measurement 1**.
 - Set the horizontal **SCALE** of the Main time base to 100 ns.

- Set the frequency of the time standard to 1.0 MHz (or a period of 1.00 μ s).
- Adjust the amplitude of the time standard for a 5 to 7 division display.
- Press **CLEAR MENU**.
- Press **SET LEVEL TO 50%**.
- Rotate the horizontal and vertical **POSITION** controls to move the rising edge of the waveform so that it crosses the center of both the horizontal and vertical graticule lines.
- Press **HORIZONTAL MENU**; then press the main-menu button **Time Base**. Press the side-menu button **Delayed Only**
- Use the horizontal **SCALE** knob to set the **D** (delayed) time base to 100 ns.
- Press the side-menu button **Delayed Runs After Main**; then use the **General Purpose** knob to set **Delayed Runs After Main** to 10.0 μ s.
- CHECK that the rising edge of the waveform crosses the center horizontal graticule line at a point within ± 0.5 divisions of the center graticule (see Figure 4-11).
- Use the horizontal **SCALE** knob to set the **D** (delayed) time base to 50 μ s. (The scale of the Main time base will also change.)
- Use the **General Purpose** knob to set **Delayed Runs After Main** to 100 μ s.
- Use the horizontal **SCALE** knob to set the **D** (delayed) time base to 100 ns.
- CHECK that the rising edge of the waveform crosses the center horizontal graticule line at a point within ± 0.5 divisions of the center graticule.

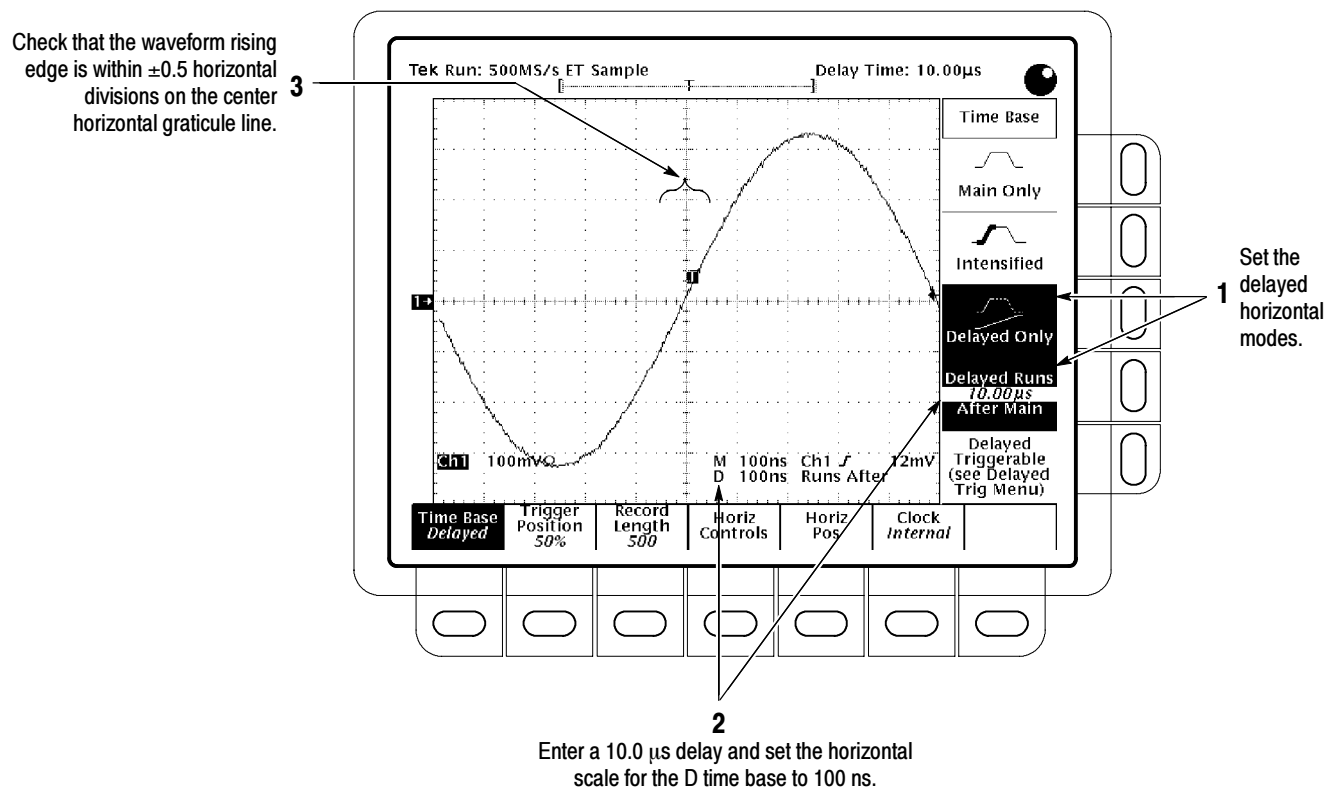

Figure 4- 11: Measurement of Accuracy — Long-Term and Delay-Time

- Set the horizontal **SCALE** of the **D** (delayed) time base to 500 μ s. (The scale of the Main time base will also change.)
 - Use the **General Purpose** knob to set **Delayed Runs After Main** to 1.00 ms.
 - Use the horizontal **SCALE** knob to set the **D** (delayed) time base to 100 ns.
 - **CHECK** that the rising edge of the waveform crosses the center horizontal graticule line at a point within ± 1.5 divisions of the center graticule.
3. *Disconnect the hookup:* Disconnect the cable from the time standard at the input connector of **CH 1**.

Trigger System Checks

These procedures check those characteristics that relate to the Main and Delayed trigger systems and are listed as checked under *Warranted Characteristics* in Chapter 1, *Specification*.

Check Accuracy, Trigger Level or Threshold, DC Coupled

Equipment Required	One DC calibration generator (Item 10) One BNC T connector (Item 8) Two precision coaxial cables (Item 5)
Prerequisites	See page 4-15.

1. Install the test hookup and preset the instrument controls:

a. Hook up the test-signal source:

- Set the output of a DC calibration generator to 0 volts.
- Connect the output of a DC calibration generator through a dual-banana connector followed by a 50 Ω precision coaxial cable to one side of a BNC T connector.
- Connect the Sense output of the generator, through a second dual-banana connector followed by a 50 Ω precision coaxial cable, to the other side of the BNC T connector. Now connect the BNC T connector to **CH 1** (see Figure 4-12).

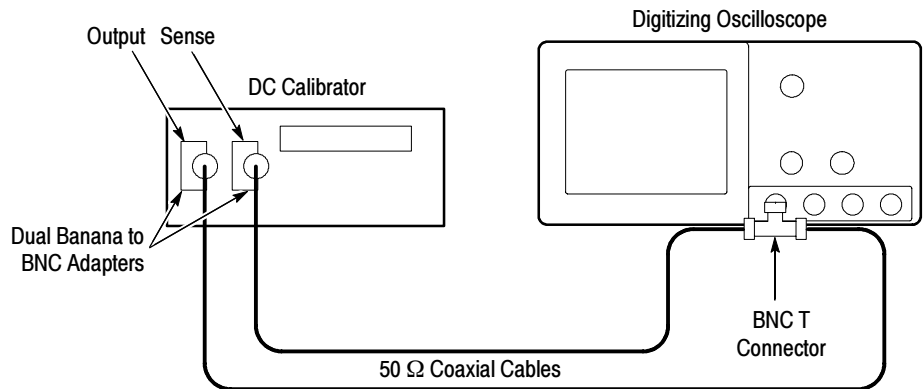

Figure 4-12: Initial Test Hookup

b. Initialize the oscilloscope:

- Press save/recall **Setup**.

- Press the main-menu button **Recall Factory Setup**.
 - Press the side-menu button **OK Confirm Factory Init**.
2. *Confirm Main trigger system is within limits for Trigger-level/Threshold accuracy:*
- a. *Display the test signal:*
 - Set the vertical **SCALE** to 50 mV.
 - Set the standard output of a DC calibration generator to +0.3 V.
 - b. *Measure the test signal:*
 - Press **SET LEVEL TO 50%**.
 - Press **TRIGGER MENU**.
 - Read the measurement results from the readout below the label **Level** in the menu rather than from the trigger readout in the graticule area.
 - c. *Check against limits:*
 - Subtract the trigger level readout from the DC calibration generator setting. The result is the trigger level accuracy.
 - CHECK that the trigger level is accurate to within ± 18 mV.
 - Press **TRIGGER MENU**. Press the main-menu button **Slope**; then press the side-menu button for negative slope. (See icon at left.) Repeat substep b.
 - Subtract the trigger level readout from the DC calibration generator setting. The result is the trigger level accuracy.
 - CHECK that the trigger level is accurate to within ± 18 mV.
3. *Confirm Delayed trigger system is within limits for Trigger-level/Threshold accuracy:*
- a. *Select the Delayed time base:*
 - Press **HORIZONTAL MENU**.
 - Press the main-menu button **Time Base**.
 - Press the side-menu buttons **Delayed Only** and **Delayed Triggerable**.
 - Set **D** (delayed) horizontal **SCALE** to 500 μ s.



- b. *Select the Delayed trigger system:*
 - Press **SHIFT**; then press the front-panel button **DELAYED TRIG**.
 - Press the main-menu button **Level**.
- c. *Measure the test signal:* Press the side-menu button **SET TO 50%**. Read the measurement results in the side menu below the label **Level**.
- d. *Check against limits:* Do the following subparts in the order listed.
 - Subtract the trigger level readout from the DC calibration generator setting. The result is the trigger level accuracy.
 - CHECK that the trigger level is accurate to within ± 18 mV.
 - Press **TRIGGER MENU**. Press the main-menu button **Slope**; then press the side-menu button for negative slope. (See icon at left.)
 - Subtract the trigger level readout from the DC calibration generator setting. The result is the trigger level accuracy.
 - CHECK that the trigger level is accurate to within ± 18 mV.



- 4. *Disconnect the hookup:*
 - a. *First set the output of the DC calibration generator to 0 volts.*
 - b. Then disconnect the cable from the generator output at the input connector of **CH 1**.

**Sensitivity, Edge Trigger,
DC Coupled**

Equipment Required	One sine wave generator (Item 11) One precision 50 Ω coaxial cable (Item 5) One 10X attenuator (Item 1) One 5X attenuator (Item 2)
Prerequisites	See page 4-15.

- 1. *Install the test hookup and preset the oscilloscope controls:*
 - a. *Initialize the oscilloscope:*
 - Press save/recall **SETUP**.
 - Press the main-menu button **Recall Factory Setup**.
 - Press the side-menu button **OK Confirm Factory Init**.

b. *Modify the initialized front-panel control settings:*

- Set the horizontal **SCALE** for the **M** (main) time base to 20 ns.
- Press **HORIZONTAL MENU**; then press the main-menu button **Time Base**.
- Press the side-menu button **Delayed Only**; then press the side-menu button **Delayed Triggerable**.
- Set the horizontal **SCALE** for the **D** (delayed) time base to 20 ns; then press the side-menu button **Main Only**.
- Press **TRIGGER MENU**; then press the main-menu button **Mode & Holdoff**. Now press the side-menu button **Normal**.
- Press **VERTICAL MENU**; then press the main-menu button **Coupling**. Now press the side-menu button Ω to select the 50 Ω setting.
- Press **SHIFT**; then press **ACQUIRE MENU**. Now press the main-menu button **Mode**; then press the side-menu button **Average 16**.

c. *Hook up the test-signal source:* Connect, through a 50 Ω precision coaxial cable, the signal output of a sine wave generator to **CH 1** (see Figure 4-13).

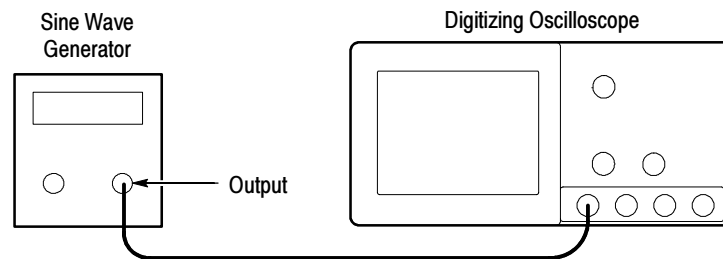

Figure 4-13: Initial Test Hookup

2. *Confirm Main and Delayed trigger systems are within sensitivity limits (50 MHz):*

a. *Display the test signal:*

- Set the generator frequency to 50 MHz.
- Press **MEASURE**.



- Press the main-menu button **High-Low Setup**; then press the side-menu button **Min-Max**.
 - Press the main-menu button **Select Measurement for Ch1**.
 - Press the side-menu button **-more-** until **Amplitude** appears in the side menu (its icon is shown at the left). Press the side-menu button **Amplitude**.
 - Adjust the trigger **MAIN LEVEL** knob to obtain stable triggered waveform.
 - Press **CLEAR MENU**.
 - Set the test signal amplitude for about three and a half divisions on screen. Now fine adjust the generator output until the **CH 1 Amplitude** readout indicates the amplitude is 350 mV. (Readout may fluctuate around 350 mV.)
 - Disconnect the 50 Ω precision coaxial cable at **CH 1** and reconnect it to **CH 1** through a 10X attenuator.
- b. *Check for Main trigger system for stable triggering at limits:*
- Read the following definition: A stable trigger is one that is consistent; that is, one that results in a uniform, regular display triggered on the selected slope (positive or negative). This display should *not* have its trigger point switching between opposite slopes, nor should it “roll” across the screen. At horizontal scale settings of 2 ms/division and faster, **TRIG'D** remains constantly lit. It flashes for slower settings.
 - Press **TRIGGER MENU**; then press the main-menu button **Slope**.
 - Press **SET LEVEL TO 50%**. CHECK that a stable trigger is obtained for the test waveform on both the positive and negative slopes. (Use the side menu to switch between trigger slopes; use the trigger **MAIN LEVEL** knob to stabilize the trigger if required.)
 - Leave the Main trigger system triggered on the positive slope of the waveform before continuing to the next step.

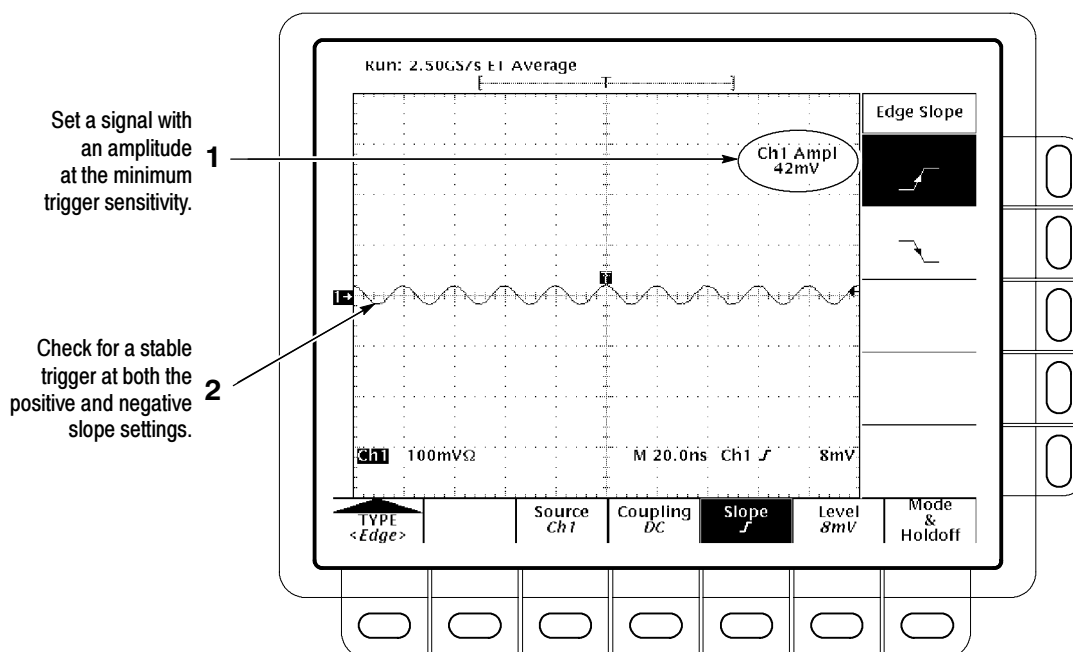

Figure 4-14: Measurement of Trigger Sensitivity

- c. *Check delayed trigger system for stable triggering at limits: Do the following subparts in the order listed.*
 - Press **HORIZONTAL MENU**; then press the main-menu button **Time Base**. Now press the side-menu button **Delayed Only**.
 - Press **SHIFT**; then press **DELAYED TRIG**. Press the main-menu button **Level**.
 - Press the side-menu button **SET TO 50%**. CHECK that a stable trigger is obtained for the test waveform for both the positive and negative slopes of the waveform. (Use the General Purpose knob to stabilize the trigger if required.) Press the main-menu button **Slope**; then use the side menu to switch between trigger slopes.
 - Leave the delayed trigger system triggered on the positive slope of the waveform before continuing to the next step. Also, return to the main time base: Press **HORIZONTAL MENU**; then press the main-menu button **Time Base**. Now press the side-menu button **Main Only**.
3. *Confirm that the Main and Delayed trigger systems are within sensitivity limits (at upper frequency limits):*
 - a. *Hook up the test-signal source: Disconnect the hookup installed in step 1. Connect the signal output of a sine wave generator to **CH 1**.*

- b. *Set the Main and Delayed Horizontal Scales:*
 - Set the horizontal **SCALE** to 5 ns for the **M** (Main) time base.
 - Press the side-menu button **Delayed Only**.
 - Set the horizontal **SCALE** to 2 ns for the **D** (Delayed) time base. Press the side-menu button **Main Only**.
 - c. *Display the test signal:*
 - Set the generator frequency to 350 MHz (TDS 420A) or 500 MHz (TDS 430A and TDS 460A).
 - Set the test signal amplitude for about five divisions on screen. Now fine adjust the generator output until the **CH 1 Amplitude** readout indicates the amplitude is 500 mV. (Readout may fluctuate around 500 mV.)
 - Disconnect the sine wave at **CH 1** and reconnect it to **CH 1** through a 5X attenuator.
 - d. Repeat step 2, substeps b and c only.
4. *Confirm that the Main and Delayed trigger systems couple trigger signals from all channels:* Doing the procedure *Check Analog Bandwidth*, which begins on page 4-25, checks coupling. If you have not done that procedure, do so after finishing this procedure. See the following note.

NOTE. *Steps 1 through 3 confirmed trigger sensitivity for the Main and Delayed triggering systems using the CH 1 input. Doing the procedure Check Analog Bandwidth ensures that trigger signals are coupled from all channels.*

5. *Disconnect the hookup:* Disconnect the cable from the generator output at the input connector of the channel last tested.

**Maximum Input
Frequency, Auxiliary
Trigger**

Equipment Required	One sine wave generator (Item 11)
	Two precision 50 Ω coaxial cables (Item 5)
	One BNC T connector (Item 8)
Prerequisites	See page 4-15.

1. *Install the test hookup and preset the oscilloscope controls:*
- a. *Initialize the oscilloscope:*
 - Press save/recall **SETUP**.

- Press the main-menu button **Recall Factory Setup**.
 - Press the side-menu button **OK Confirm Factory Init**.
- b. Modify the initialized front-panel control settings:**
- Set the vertical **SCALE** to 1 volt; set the horizontal **SCALE** to 20 ns.
 - Press **VERTICAL MENU**.
 - Press the main-menu button **Coupling**. Press the side-menu button **Ω** to toggle it to the 50 Ω setting.
 - Press **TRIGGER MENU**. Press the main-button **SOURCE**; then press the side-menu button **-more-** until **Auxiliary** appears in the side menu. Press the side-menu button **Auxiliary**.
 - Press the **Coupling** main-menu button; then press the **AC** side-menu button.
- c. Hook up the test-signal source:**
- Connect a BNC T connector to the output of the sine wave generator (see Figure 4-15).
 - Connect one 50 Ω cable to one side of the BNC T connector; connect a second 50 Ω cable to the other side of the BNC T connector.
 - Connect one of the cables just installed to **CH 1**; connect the other cable just installed to the **AUX TRIGGER** input at the rear panel.

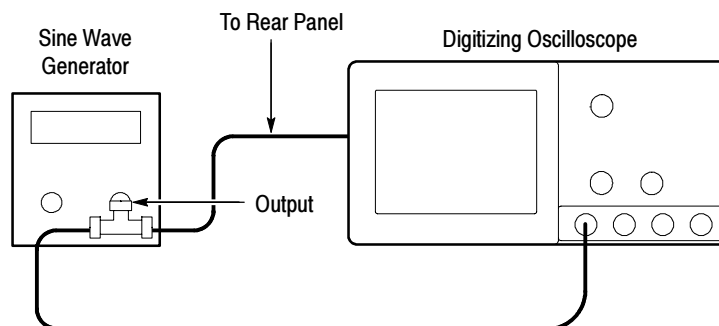

Figure 4- 15: Initial Test Hookup

NOTE. Refer to the Sine Wave Generator Leveling Procedure on page 4-55 if your sine wave generator does not have automatic output amplitude leveling.

2. Confirm the Trigger input:

a. Display the test signal:

- Set the generator for a 10 MHz, four division signal.

b. Check the Main trigger system for stable triggering at limits:

- Read the following definition: A stable trigger is one that is consistent; that is, one that results in a uniform, regular display triggered on the selected slope (positive or negative). This display should *not* have its trigger point switching between opposite slopes, nor should it “roll” across the screen (see Figure 4-16).

1 Set a signal with a four division amplitude and a 10 MHz frequency.

2 Check for a stable trigger at both the positive and negative slope settings.

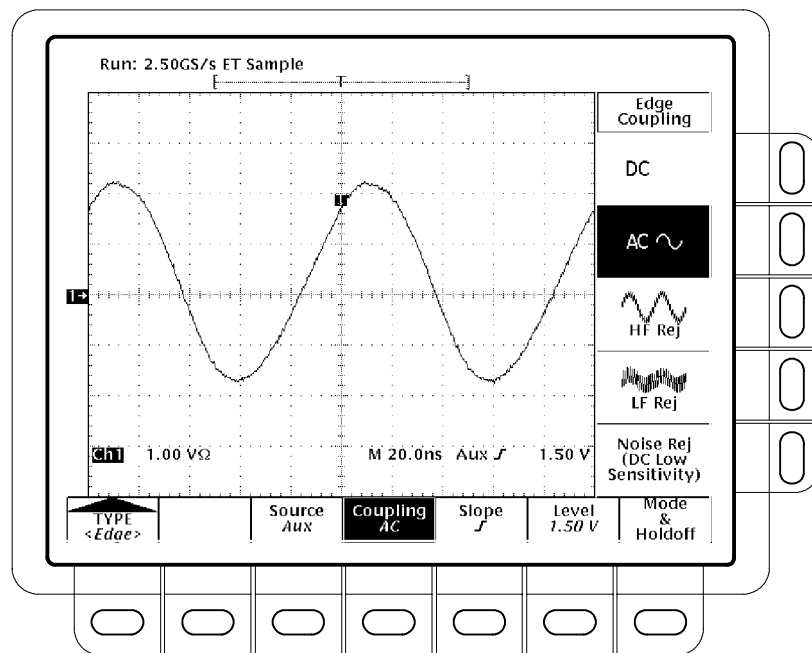

Figure 4-16: Confirming Auxiliary Triggering at Maximum Triggering Frequency

3. Disconnect the hookup: Disconnect the cable from the generator output at the input connector of the channel last tested.

Check External Clock

Equipment Required	One Function generator (Item 14) One Sine Wave generator (Item 11) One 50 Ω terminator (Item 3) One N to BNC adapter (Item 15) One BNC T connector (Item 8) Two precision coaxial cables (Item 5)
Prerequisites	See page 4-15.

1. *Install the test hookup and preset the instrument controls:*
 - a. *Initialize the oscilloscope:*
 - Press save/recall **SETUP**.
 - Press the main-menu button **Recall Factory Setup**.
 - Press the side-menu button **OK Confirm Factory Init**.
 - b. *Hook up the test-signal source:*
 - Set the Vertical **SCALE** to 1 Volt per division.
 - Connect the output of a function generator through a 50 Ω precision coaxial cable and a 50 Ω terminator to the **CH 1** input.
 - Set the output of the function generator for a 5 MHz, 0 to 4 Volt (4 division) square wave at the oscilloscope input.
 - Move the setup from the **CH 1** input to the **AUX TRIGGER/EXT CLOCK** input on the rear panel of the oscilloscope (see Figure 4-17).

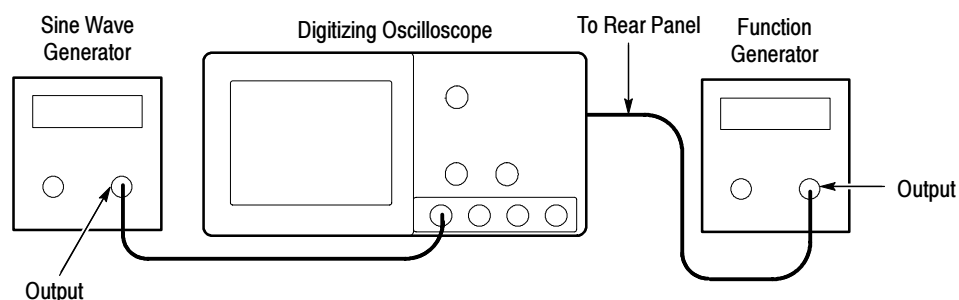
**Figure 4-17: Initial Test Hookup**

- Connect the output of the sine wave generator through an N-to-BNC adaptor, and a 50 Ω precision coaxial cable to the **CH 1** input of the oscilloscope.
 - Set the Vertical **SCALE** to 100 mV.
 - Press **VERTICAL MENU**, then press the **Coupling** main-menu button.
 - Set the coupling to **50 Ω** .
 - Set the output of the sine wave generator for a 100 KHz 4 division sine wave.
- c. *Modify the default settings:*
- Press **HORIZONTAL MENU**, then press the **Clock** main-menu button.
 - Press the side-menu button **External**.
 - Set the **Max Ext Clock Rate** to 10.0 MHz.
 - Press **CLEAR MENU**.
- d. *Check external clock:*
- CHECK that the displayed sine wave has a one division period.
 - Slowly adjust the frequency of the function generator to 10 MHz while watching the display.
 - CHECK that the period of the displayed sine wave changes to two divisions.
 - Press **CLEAR MENU**.
2. *Disconnect the hookup:* Disconnect the cables from the generators at the **CH 1** and **AUX TRIGGER/EXT CLOCK** input connectors.

**Check Video Trigger
Sensitivity
(Option 05 Equipped
Models Only)**

Equipment Required	One NTSC format video generator (Item 18) One 75 Ω coaxial cable (Item 6) One 75 Ω terminator (Item 4)
Prerequisites	See page 4-15.

1. *Install the test hookup and preset the oscilloscope controls:*
 - a. *Initialize the oscilloscope:*
 - Press save/recall **SETUP**.
 - Press the main menu button **Recall Factory Setup**.
 - Press the side menu button **OK Confirm Factory Init**.
 - b. *Modify the default setup:*
 - Set the vertical **SCALE** to 500 mV.
 - Set the horizontal **SCALE** to 20 μ s.
 - Press **HORIZONTAL MENU**.
 - Press the main menu button **Record Length**.
 - Press the side menu button **5000 points in 100 divs**.
 - c. *Hook up the test-signal source:* Connect, through a 75 Ω precision coaxial cable, followed by a 75 Ω terminator, the output of a NTSC format video generator to CH 1 (see Figure 4-18).

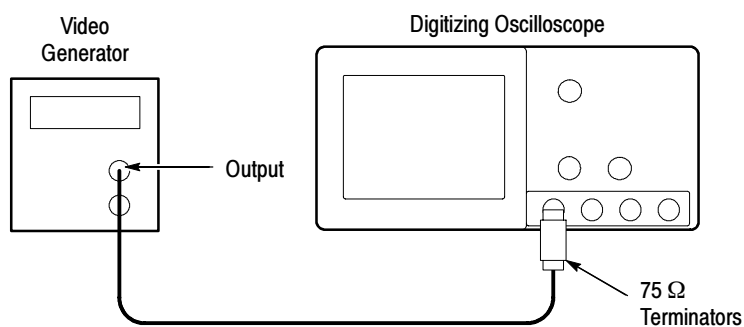

Figure 4- 18: Initial Test Hookup

2. *Confirm the video trigger system is within limits:*

a. *Display the test signal:*

- Set video generator to NTSC format.
- Set the output of the generator for a five step ramp with color burst.
- Press **SET TO 50%**. Use the trigger **MAIN LEVEL** knob to stabilize the display as required.
- Press **TRIGGER MENU**.
- Press the main menu button **Mode & Holdoff**. Then press the side menu button **Normal**.

b. *Fine adjust the sync pulse amplitude:* The amplitude of the TV waveform should now be about 2 divisions pk-pk. Do the following subparts to fine adjust the vertical gain until the sync pulses measure exactly 0.6 divisions peak-to-peak using the graticule:

- Press **VERTICAL MENU**.
- Press the main menu button **Fine Scale**.
- Use the General Purpose knob, adjust the fine gain until the sync pulse amplitude is 0.6 divisions measured using the graticule (see Figure 4-19).

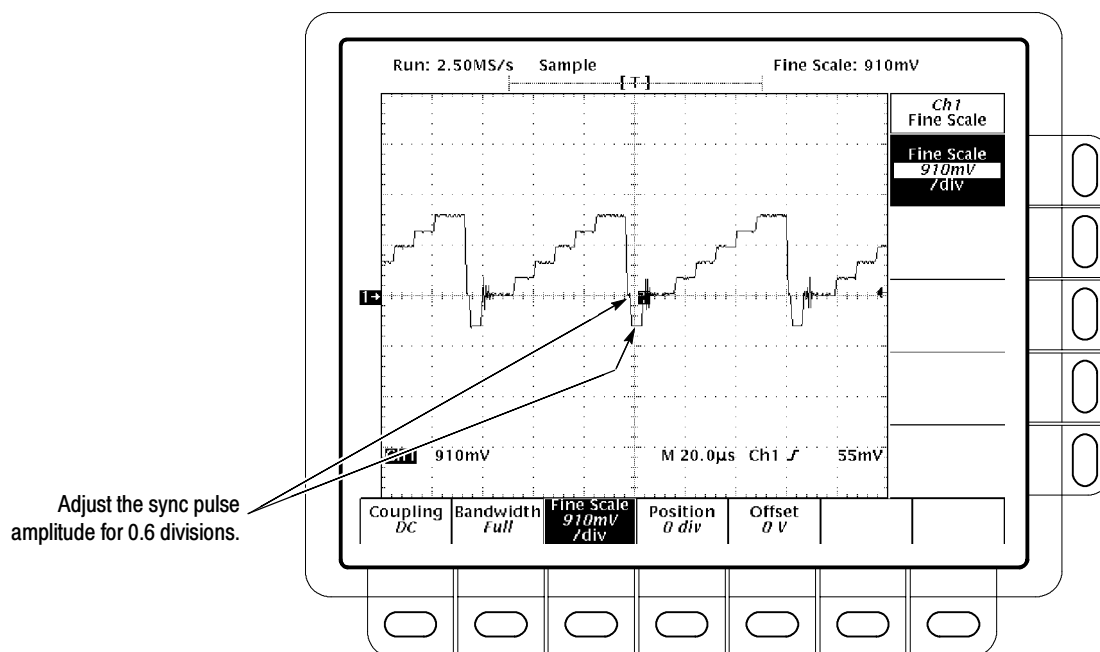

Figure 4-19: Adjusting Sync Pulse Amplitude

c. Check for stable triggering against limits:

- Read the following definition: A stable trigger is one that is consistent; that is, one that results in a uniform, regular display triggered on the selected slope (positive or negative). This display should *not* have its trigger point switching between opposite slopes, nor should it “roll” across the screen. At horizontal scale settings appropriate for viewing video waveforms, the **TRIG'D** light remains constantly lit.
- Press **TRIGGER MENU**. Press the main menu button **Type** twice — first to pop up its menu and then to toggle it to **Video**.
- Press the main menu button **Class** to pop up its menu. Press it again as needed to toggle it to **NTSC**.
- Press the main menu button **Scan** to pop up its menu.
- Press the side menu button **Odd**. Center the display at mid screen.
- CHECK that a stable trigger is obtained with the last two lines of TV field 2 and the beginning of TV field 1 displayed. (If the last line is a full TV line duration ($63.5 \mu\text{s}$), then it is the end of field 2 — see waveform R1 in Figure 4-20.)
- Press the side menu button **Even**. Center the display at mid screen.

- CHECK that a stable trigger is obtained with the last of TV field 1 and the beginning of TV field 2 displayed. (If the last line is $\frac{1}{2}$ of a TV line duration ($31.75 \mu\text{s}$), then it is the end of field 1 — see waveform R2 in Figure 4-20.)
- Press the side menu button **All**.
- Press the main menu button **Mode and Holdoff**. Then press the side menu button **Holdoff**.
- Use the **General Purpose** knob to set the holdoff to **1**.

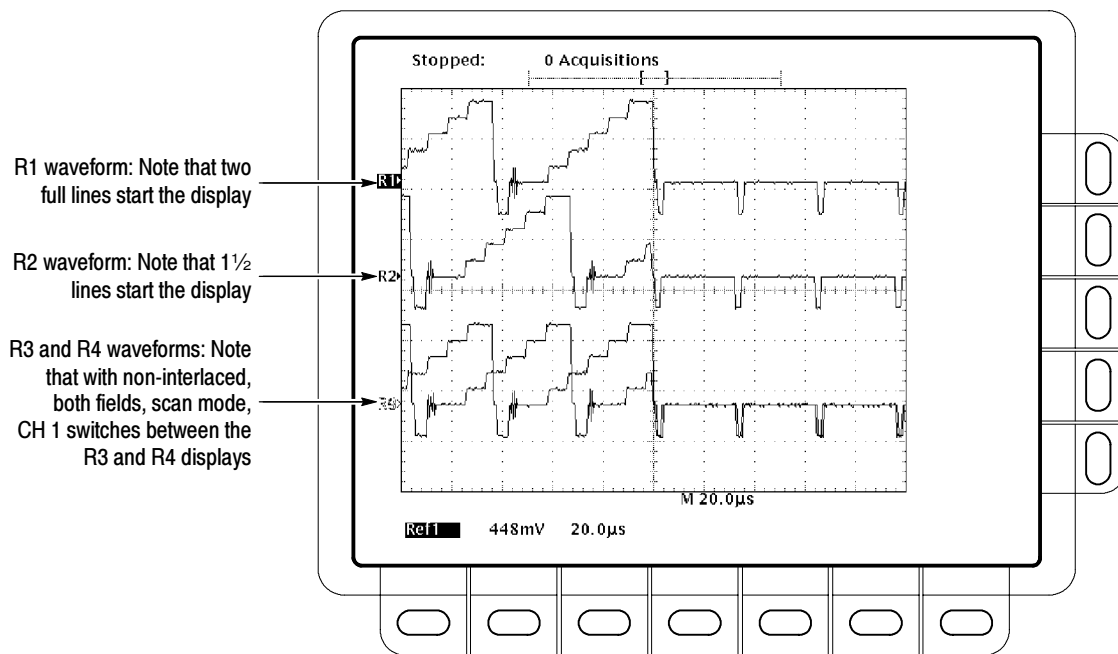

Figure 4-20: Measurement of Video Sensitivity

- Rotate the horizontal **POSITION** control clockwise to move the ends of both fields to the center of the display.
 - CHECK that a stable trigger is obtained while alternating between field 1 and field 2. (If the last line is alternating between a full TV line and $\frac{1}{2}$ a line in duration ($63.5 \mu\text{s}$ and $31.75 \mu\text{s}$ respectively), then triggering is occurring on both fields — see waveforms R3 and R4 in Figure 4-20.)
- d. *Check delay by lines:*
- Press the main-menu button **Scan**.

- Press the side-menu button **Odd**.
 - Rotate the horizontal **POSITION** control counter clockwise and align the trigger “**T**” to center screen
 - Press the main-menu button **TV Delay Mode**.
 - Press the side-menu button **Line**.
 - Use the General Purpose knob to set the line count to **10**.
 - CHECK that the selected line is the first line that has the color burst signal.
- e. *Check sync trigger:*
- Using the Vertical **POSITION** knob, move the video waveform from the top to the bottom of the display.
 - CHECK that the **TRIG'D** LED stays on and the waveform is stable.
 - Using the Vertical **POSITION** knob return the waveform to the center of the display.
3. *Disconnect the hookup:* Disconnect the cable from the generator output at the input connector of **CH 1**.

Output Signal Check

The procedure that follows checks the characteristics of the probe compensation signal that are listed as checked under *Warranted Characteristics* in Chapter 1, *Specification*.

Check Probe Adjust Output

Equipment Required	One standard-accessory 10X probe (Item 17)
Prerequisites	See page 4-15. Also, this digitizing oscilloscope must have passed <i>Check Accuracy — Long-Term Sample Rate, Delay time, and Delta Time Measurements</i> on page 4-34, and <i>Check DC Voltage Measurement Accuracy (Averaged)</i> on page 4-22.

1. *Install the test hookup and preset the oscilloscope controls:*
- a. *Hook up test signal:* Install the standard-accessory probe on **CH 1**. Connect the probe tip to **PROBE ADJ** on the front panel; leave the probe ground unconnected (see Figure 4-21).

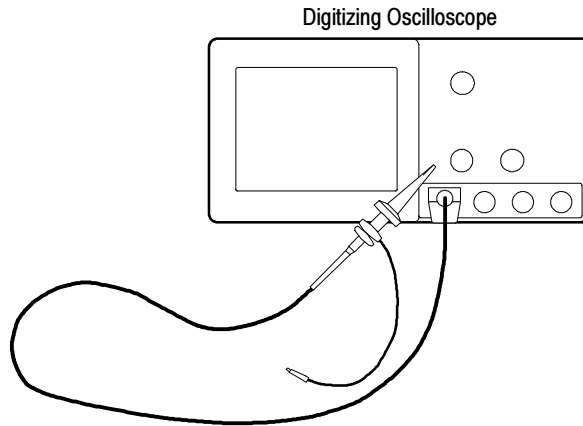

Figure 4-21: Initial Test Hookup

b. Initialize the oscilloscope:

- Press save/recall **SETUP**.
- Press the main-menu button **Recall Factory Setup**.
- Press the side-menu button **OK Confirm Factory Init**.

c. Modify the initialized front-panel control settings:

- Press **AUTOSET**. Set the horizontal **SCALE** to 200 μ s.
- Press **SHIFT**; then press **ACQUIRE MENU**.
- Press the main-menu button **Mode**; then press the side-menu button **Hi Res**.

2. Confirm that the Probe Compensator signal is within limits for amplitude and frequency:

a. Measure the amplitude and frequency of the probe compensation signal:

- Press **MEASURE**; then press the main-menu button **Select Measurement for Ch1**.
- Now repeatedly press the side-menu button **-more-** until **Amplitude** appears in the side menu (its icon is shown at the left). Press the side-menu button **Amplitude**.
- Repeatedly press the side-menu button **-more-** until **Frequency** appears in the side menu (its icon is shown at the left). Press the side-menu button **Frequency**.



- Press **CLEAR MENU** to remove the menus from the display. See Figure 4-22.

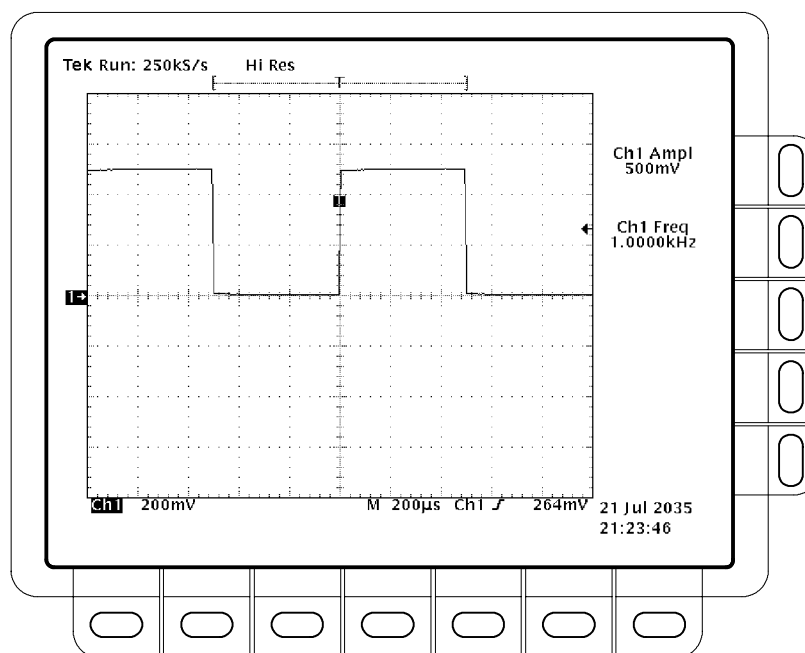

Figure 4-22: Measurement of Probe Compensator Limits

- Check against limits:* CHECK that the **CH 1 Freq** readout is within 950 Hz to 1.050 kHz, inclusive, and that the readout for **Ch1 Ampl** is within 475 mV to 525 mV, inclusive.
- Disconnect the test hookup:* Remove the test probe as desired.

Sine Wave Generator Leveling Procedure

Some procedures in this manual require a sine wave generator to produce the necessary test signals. If you do not have a leveled sine wave generator, use one of the following procedures to level the output amplitude of your sine wave generator.

Procedure for Best Accuracy

Equipment Required	Sine Wave Generator (Item 11) Level Meter and Power Sensor (Item 12) Power Splitter (Item 13) Two Male N to Female BNC Adapters (Item 15) One precision coaxial cable (Item 5)
Prerequisites	See page 4-15.

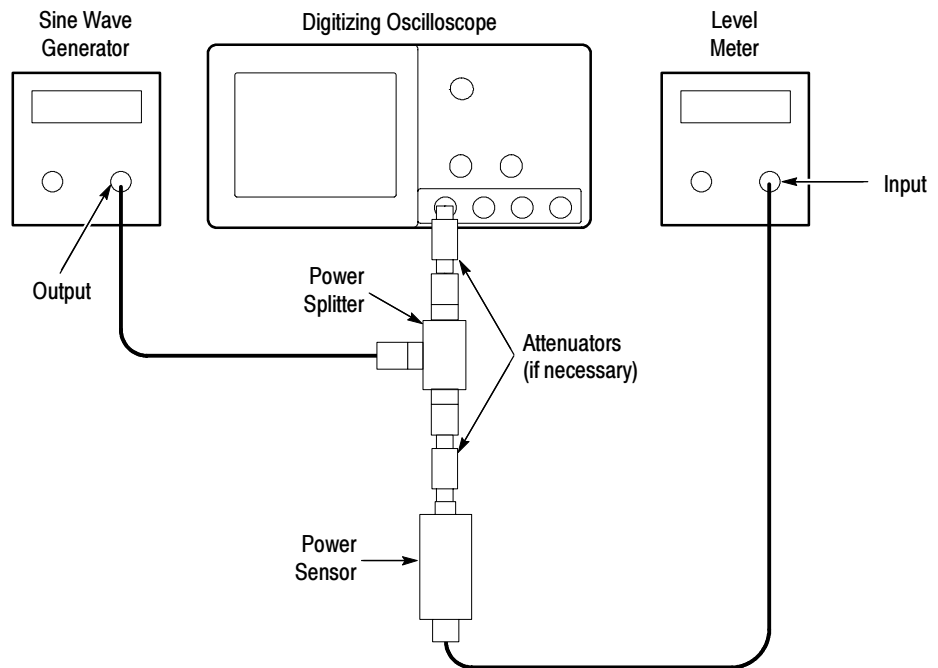

Figure 4-23: Sine Wave Generator Leveling Equipment Setup

1. *Install the test hookup:* Connect the equipment as shown in Figure 4-23.
2. *Set the Generator:*
 - Set the sine wave generator to a reference frequency of 10 MHz.
 - Adjust the sine wave generator amplitude to the required number of divisions as measured by the digitizing oscilloscope.
3. *Record the reference level:* Note the reading on the level meter.
4. *Set the generator to the new frequency and reference level:*
 - Change the sine wave generator to the desired new frequency.

- Input the correction factor for the new frequency into the level meter.
- Adjust the sine wave generator amplitude until the level meter again reads the value noted in step 3. The signal amplitude is now correctly set for the new frequency.

Alternate Procedure for Maximum Amplitude

Equipment Required	Sine Wave Generator (Item 11)
	Level Meter and Power Sensor (Item 12)
	Two Male N to Female BNC Adapters (Item 15)
	Two precision coaxial cables (Item 5)
Prerequisites	See page 4-15.

1. *Install the test hookup:* Connect the equipment as shown in Figure 4-24 (start with the sine wave generator connected to the digitizing oscilloscope).

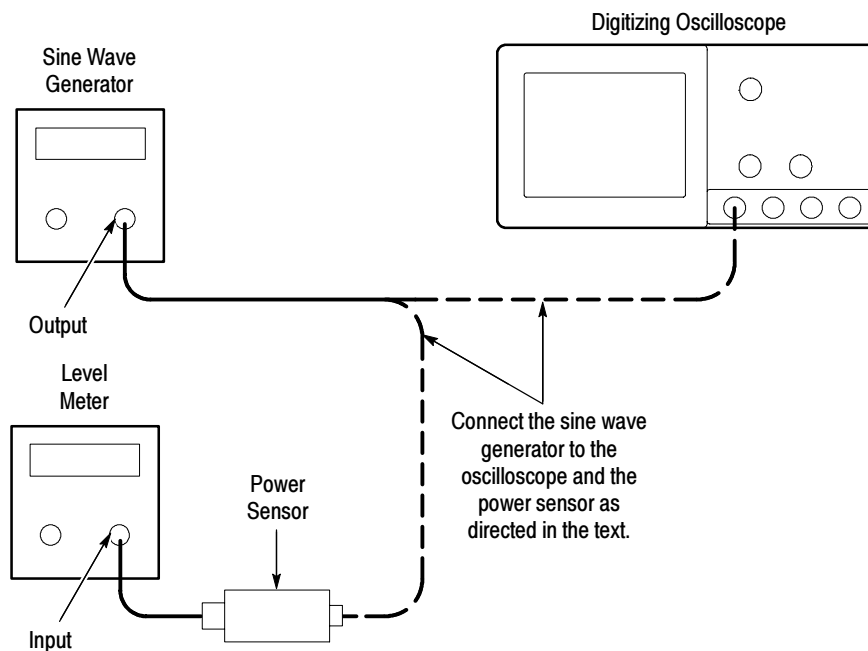

Figure 4-24: Equipment Setup for maximum Amplitude

2. *Set the Generator:*
 - Set the sine wave generator to a reference frequency of 10 MHz.
 - Adjust the sine wave generator amplitude to the required number of divisions as measured by the digitizing oscilloscope.

3. *Record the reference level:*

- Disconnect the sine wave generator from the digitizing oscilloscope.
- Connect the sinewave generator to the power sensor.
- Note the level meter reading.

4. *Set the generator to the new frequency and reference level:*

- Change the sine wave generator to the desired new frequency.
- Input the correction factor for the new frequency into the level meter.
- Adjust the sine wave generator amplitude until the level meter again reads the value noted in step 3. The signal amplitude is now correctly set for the new frequency.
- Disconnect the sine wave generator from the power sensor.
- Connect the sinewave generator to the digitizing oscilloscope.

Adjustment Procedures

This chapter contains information needed to adjust the TDS 420A, TDS 430A, and TDS 460A Digitizing Oscilloscopes.

- Description** The *Adjustment Procedures* are divided into three parts:
- This general information about adjusting this oscilloscope and the written procedures for installing and using the adjustment software.
 - The *TDS 420A, TDS 430A, & TDS 460A Adjustment Software* included with this manual. Read the material in this section before using the adjustment software.
 - Two written procedures for manually adjusting the probe and the monitor assembly.

Purpose Use this procedure to return the oscilloscope to conformance with its *Warranted Characteristics* (they are listed starting on page 1-15). You can also use this procedure to optimize the performance of the oscilloscope.

This procedure is *not* required to verify the oscilloscope conforms with its warranted characteristics; performance verification procedures are found in the *Performance Verification*, starting on page NO TAG.

Adjustment Interval As a general rule, these adjustments should be done every 2,000 hours of operation or once a year if used infrequently.

Requirements for Performance

Before you do this procedure, you need to address the following requirements.

Personnel Only trained service technicians should perform these procedures.

Warm-up Period This oscilloscope requires a 20 minute warm-up period in a 20° C to 30° C environment before it is adjusted. Adjustments done before the operating temperature has stabilized may cause errors in performance.

Access Except when adjusting the monitor assembly, the cabinet is not removed. (A monitor adjustment is not done as part of a routine adjustment — see *Complete Adjustment* on page 5-2.)

System The following computer and peripherals are required to adjust this oscilloscope; the adjustment software does not run on systems that do not meet *all* requirements listed:

An IBM® PC™ compatible computer equipped as follows:

- Eight MHz clock speed or faster
- MSDOS® 3.2 or higher
- 640K Resident RAM, with 580K available
- A hard drive
- A high-density floppy drive: 3.5 inch (1.44 M) or 5.25 inch (1.2 M)
- A GPIB board — National Instruments® GPIB-PCII, GPIB-PCIIA or GPIB-PCII/IIA. (A PC-GPIB package that includes the PCII/IIA is available — Tektronix part number S3FG210)
- Suitable keyboard and monitor

Optional Peripherals Installation of a math coprocessor in your system is strongly recommended to decrease the time required to adjust the oscilloscope.

Test Equipment The equipment list on page 5-5 lists all test equipment required to adjust this oscilloscope.

Usage

The following topics cover what is required of you when adjusting the oscilloscope and what is done by the software. Also, the performance of individual adjustments is discussed.

Performing the Adjustments When using the adjustment software, you are not required to manually adjust any circuits. The software adjusts the circuits using external standards you provide in response to prompts on the computer screen. Your role is to provide those test signals and to prompt the computer to continue.

Since the probe and monitor-assembly adjustments require manual adjustment of circuit components, they are not part of the adjustment software. Written procedures for these adjustments begin on page 5-10.

Complete Adjustment A complete adjustment is the performance of all adjustments contained in the Adjustment Software plus the probe adjustment on page 5-10. Therefore, to do a

complete adjustment, *do all adjustments in the software, completely and in sequence, and then do the written probe adjustment procedure.*

Throughout this chapter, “complete adjustment” is used as just defined. Note that the procedure *Monitor Assembly Adjustment* (page 5-21) is *not* required to do a complete adjustment.

Individual Adjustments

The adjustment software contains a sequence of individual adjustments. The list of those adjustments follows:

- Signal Path Compensation
- Voltage Reference Adjustment
- High Frequency Response Adjustment (TDS 430A and TDS 460A only)
- Low Frequency Response Adjustment
- Trigger Skew Adjustment

All these software-based adjustments are made internally by the adjustment software, and all adjustments are done without removal of the oscilloscope cabinet.

Partial Adjustment

The adjustment software allows you to make individual adjustments. However, usually all adjustments are made unless you are adjusting circuits in the course of troubleshooting the oscilloscope. Read the information under *Complete Adjustment*, page 5-2, *Adjustment After Repair*, page 5-3, and *Adjustment Dependencies*, page 5-4, before doing an individual adjustment.

Adjustment After Repair

After the removal and replacement of a module due to electrical failure, you either must do a complete adjustment or no adjustment is required, depending on the module replaced. See Table 5-1.

Table 5-1: Adjustments Required for Module Replaced

Module Replaced	Adjustment Required
Acquisition Board	Complete Adjustment
Attenuator Board	Complete Adjustment
Front Panel Assembly	None Required
Low Voltage Power Supply	Complete Adjustment
CPU Assembly	Complete Adjustment
DSP Assembly	None Required
Display Assembly	None Required

Table 5-1: Adjustments Required for Module Replaced (Cont.)

Module Replaced	Adjustment Required
Auxiliary Power Supply	None Required
Backplane Assembly	None Required
Monitor Assembly	None Required

Adjustment Dependencies

Some adjustments depend on the successful prior completion of other adjustments. For example, the Voltage Reference Adjustment must pass before any other adjustments can be successfully completed. Table 5-2 lists the adjustments and their dependencies.

Table 5-2: Adjustments and Dependencies

Class of Adjustment	Prior Completion Requirements
Voltage Reference Adjustment	None
Low Frequency Response Adjustment	Voltage Reference
High Frequency Response Adjustment (TDS 430A and TDS 460A only)	Voltage Reference
Trigger Adjustment	Voltage Reference
Probe Adjustment	Voltage Reference, Low Frequency Response, and High Frequency Response
Monitor Adjustment	None

Equipment Required

The test equipment required to adjust the TDS 420A, TDS 430A, and TDS 460A Digitizing Oscilloscopes is listed in Table 5-3.

Table 5-3: Test Equipment, Fixtures, and Supplies

Item Number and Description	Minimum Requirements	Example	Purpose
1. Computer System	See description under <i>System</i> on page 5-2 for minimum and recommended requirements	Standard PC, see description under <i>System</i> on page 5-2.	Software-based adjustments
2. Adapter, BNC-female-to-BNC-female	Tektronix part number 013-0028-00	Tektronix part number 013-0028-00	Probe adjustment
3. Adapter, Probe Tip to BNC, 50 Ω termination	Tektronix part number 013-0227-00	Tektronix part number 013-0227-00	Probe adjustment
4. Adjustment Tool	0.1 inch hex wrench on both ends	GC Electronics #8606	A26 Monitor adjustment
5. Attenuator, 10X (two required)	Ratio: 10X; impedance 50 Ω ; connectors: female BNC input, male BNC output	Tektronix part number 011-0059-02	Software-based adjustments and probe adjustments
6. Attenuator, 2X	Ratio: 2X; impedance 50 Ω ; connectors: female BNC input, male BNC output	Tektronix part number 011-0069-02	Software-based adjustments
7. Cable GPIB	IEEE Std 488.1-1987/ IEEE Std 488.2-1987	Tektronix part number 002-0991-01	Software-based adjustments
8. Cable, Precision Coaxial	50 Ω , 36 in, male to male BNC connectors	Tektronix part number 012-0482-00	Software-based adjustments
9. Coupler, Dual-Input	BNC female to dual male BNC	Tektronix part number 067-0525-02	Software-based adjustments
10. Connector, Dual-Banana	BNC female to dual banana	Tektronix part number 103-0090-00	Software-based adjustments
11. Generator, DC Calibration	Variable amplitude to ± 10 V; accuracy to 0.05%	Wavetek 9100 (or, optionally, Data Precision 8200)	Software-based adjustments
12. Probe, 10X, included with this instrument	A P6138A Probe	Tektronix P6138A	Signal interconnection
13. Generator, Leveled Sine Wave, medium-frequency	200 kHz to 250 MHz; Variable amplitude from 5 mV to 4 V _{p-p} into 50 Ω ; flatness ≤ 3 %; harmonic content: 2 nd harmonic down -30 dB from fundamental; all others down -40 dB	Rohde & Schwarz SMY Sine Wave Generator, Rohde & Schwarz URV 35 Level Meter with NRV-Z8 Power Sensor, and RVZ Power Splitter, (or, optionally, TEKTRONIX SG 503 ¹ or SG5030 ² Leveled Sine Wave Generator)	Software-based adjustments

Table 5-3: Test Equipment, Fixtures, and Supplies (Cont.)

Item Number and Description	Minimum Requirements	Example	Purpose
14. Generator, Leveled Sine Wave, high-frequency	250 MHz to 500 MHz; Variable amplitude from 5 mV to 4 V _{p-p} into 50 Ω; harmonic content: 2 nd harmonic down -30 dB from fundamental; all others down -40 dB	Rohde & Schwarz SMY Sine Wave Generator, Rohde & Schwarz URV 35 Level Meter with NRV-Z8 Power Sensor, and RVZ Power Splitter, (or, optionally, TEKTRONIX SG 504 ¹ Leveled Sine Wave Generator with its leveling head or a TEKTRONIX SG 5030 ² Programmable Leveled Sine Wave Generator with its leveling head)	Software based adjustments
15. Generator, Pulse	High amplitude pulse with variable amplitude of 60 V to 100 V	Wavetek 9100 with options 100 and 250 (or, optionally, TEKTRONIX PG 506A Calibration Generator ¹)	Software based adjustments and probe adjustment
16. Head, Pulse Generator	TEKTRONIX 067-0681-01	TEKTRONIX 067-0681-01 Tunnel Diode Pulser	Probe adjustment
17. Photometer	0.1 to 200 Footlamberts (0.343 to 686 Candelas)	Tektronix J17 Photometer with J1803 Luminance Probe	Contrast adjustment

¹ Requires a TM 500 or TM5000 Series Power Module Mainframe.

² Requires a TM5000 Series Power Module Mainframe.

Adjustment Instructions

The following instructions guide you through installing the software on your system, setting up the oscilloscope for adjustment, and starting the adjustment of the oscilloscope by the software.

Hardware Installation

1. *Install the proper GPIB card (see System on page 5-2):* Use the manual accompanying your GPIB card to install and configure that card.
2. *Configure the GPIB card:*
 - a. This software is compatible with cards configured for PCII and PCIIA operation. Table 5-4 lists the default card settings.
 - b. If these settings conflict with your hardware setup, see your GPIB card manual for alternate settings.

Table 5-4: GPIB Board Configuration¹

Board Settings	GPIB-PCII	GPIB-PCIIA
Base I/O Address (hex)	2B8	2E1
Interrupt Line	7	7
DMA Channel	1	1

¹ **Systems using the combination card (GPIB-PCII/IIA) can be configured as either a GPIB-PCII or a GPIB-PCIIA.**

- c. If you have more than one GPIB card installed, this adjustment software assumes the first card (referenced 0). See your GPIB card manual for information on how to determine which card is your “0” card.

Software Installation

NOTE. ALWAYS use this installation procedure when installing this software on a new computer. This installation program uses parameters you supply (see step 2, substep c) to create a custom start-up file on your hard disk directory. After installation, you will be instructed to run this start-up batch file whenever you do software-based adjustments, so it can configure your computer properly before it runs the adjustment program. Do not simply copy the software files from one computer to another, since the start-up batch file you copy might not match the computer you copy it to.

1. *Create a working disk:* Power on and boot your system. Using the proper DOS commands, copy the adjustment software for your digitizing oscilloscope to a working disk.

2. *Install the software to hard disk:*
 - a. Install your working disk in a floppy drive and switch to that drive.
 - b. Use the appropriate commands to display the file called *README*. Read this file before continuing with this procedure.
 - c. Type *install*. *Install* asks you to specify the hard disk on which to install the adjustment software. It also prompts you to specify several GPIB-card configuration parameters.
 - d. The adjustment software is installed in a directory called *TDS400A.ADJ*.
3. *Store your installation disk:* Remove your installation disk and store it in a secure place.

Software-Based Adjustments

Equipment Required	All items that are listed for "Software-based adjustments" under "Purpose" in Table 5-3 starting on page 5-5.
---------------------------	---

1. *Hook up the oscilloscope:*
 - a. Connect the GPIB cable (Item 7) to the GPIB port at the computer rear panel. (When multiple GPIB cards are installed, connect to the GPIB0 card.)
 - b. Connect the GPIB cable (Item 7) to the GPIB port at the oscilloscope rear panel.
 - c. Power on the oscilloscope.
2. *Set up the oscilloscope:*
 - a. Press **SHIFT**; then press **UTILITY**.
 - b. Repeatedly press the main-menu button **System** until **I/O** is highlighted in the pop up menu.
 - c. Press the side-menu button **TALK/LISTEN**.
 - d. Use the General Purpose knob to set any address between 0 and 29.
3. *Let the oscilloscope warm up:* Allow a 20 minute warm up period before you begin step 4.
4. *Start the adjustment software:*
 - a. Change drives to your hard drive.
 - b. Change directories to *TDS400A.ADJ*.
 - c. Type *ADJ400A*.

- d. Follow the instructions as prompted on your computer screen.

NOTE. *The adjustment software prompts you to enter the ambient temperature. Enter the exact ambient temperature, within $\pm 1^{\circ}$ C. Failure to enter the temperature as just specified results in an adjustment of the oscilloscope that can degrade oscilloscope performance across the specified operating temperature range.*

5. *When adjustment is completed:*
 - a. To do a complete adjustment as defined on page 5-2, do the procedure *Probe Adjustment* on page 5-10.

Probe Adjustment

Probe adjustment is divided into three parts: *Compensate the Probe*, *Measure the Probe Bandwidth*, and *Adjust the Probe High-Frequency Response*. If probe bandwidth is within required limits, do *not* do the high frequency response adjustment.

Compensate the Probe

Equipment Required	The P6138A probe (Item 12)
	The probe adjustment tool included as a probe accessory

1. *Install the test hookup and preset the oscilloscope controls:*

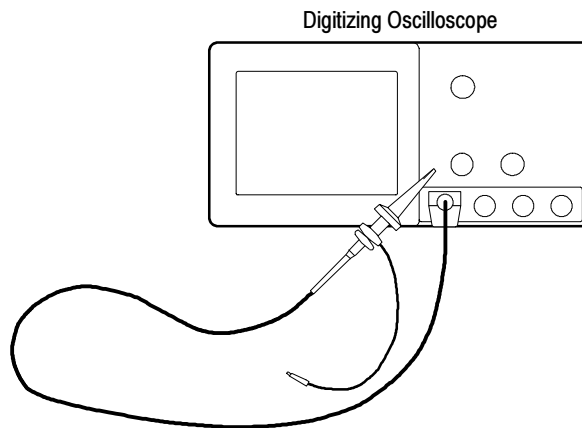

Figure 5- 1: Hookup for Probe Compensation

- Hook up test-signal source:* Install the standard-accessory probe to **CH 1**. Connect the probe tip to **PROBE ADJ** on the front panel; leave the probe ground unconnected.
- Initialize the oscilloscope:*
 - Press save/recall **SETUP**.
 - Press the main-menu button **Recall Factory Setup**.
 - Press the side-menu button **OK Confirm Factory Init**.
- Modify the initialized front-panel control settings:*
 - Press **AUTOSET**. Set the horizontal **SCALE** to 200 μ s.
 - Press **SET LEVEL TO 50%**.

- Press **VERTICAL MENU**.
- Push the main-menu button **Bandwidth**. Then push the side-menu button **20 MHz**.
- Press **SHIFT**. Then press **ACQUIRE MENU**.
- Press the main-menu button **Mode**. Then press the side-menu button **Hi Res**.

2. *Compensate the Probe:*

- a. Locate the probe compensation hole in the side of the probe body (see Figure 5-2).
- b. Using the probe compensation tool, adjust the probe for best square wave compensation (flat as possible across the top of the waveform). (See Figure 5-3.)

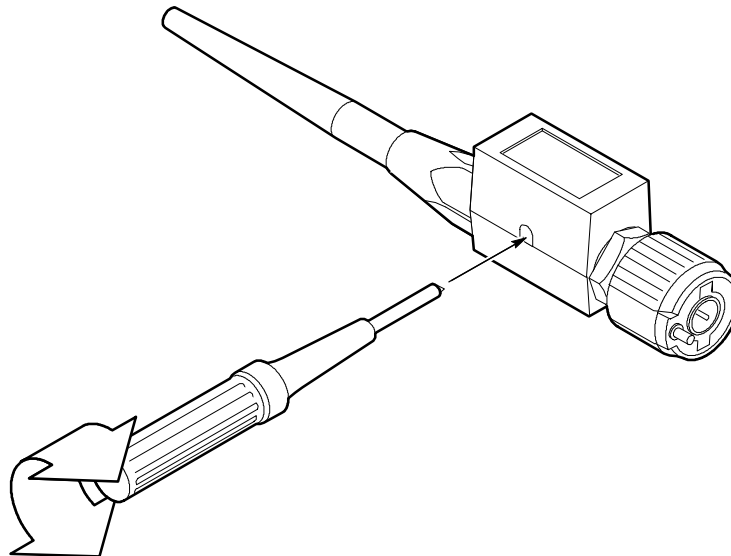

Figure 5-2: Performing Probe Compensation

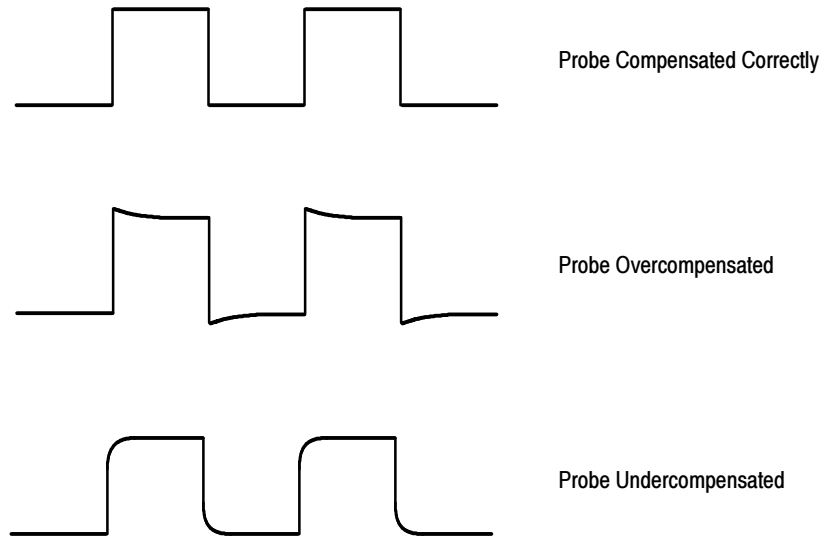

Figure 5-3: Proper and Improper Probe Compensation

3. *Disconnect the hookup:* Disconnect the probe from the probe adj (adjust) terminals; leave the probe installed on CH 1 and leave the oscilloscope control setup as is for doing the next part of the probe adjustment.

Measure the Probe Bandwidth

Equipment Required	TDS 420A: one leveled sine wave generator (Item 13) TDS 430A and TDS 460A: one leveled sine wave generator (Item 14) One BNC female to BNC female adapter (Item 2) One 50 Ω BNC to probe tip adapter (Item 3) One P6138A 10X probe (Item 12).
---------------------------	--

1. *Install the test hookup and preset the oscilloscope controls:*
 - a. *Expose the Inner Probe Tip:* Follow the instructions in Figure 5-4.

NOTE. Refer to the Sine Wave Generator Leveling Procedure on page 4-55 if your sine wave generator does not have automatic output amplitude leveling.

- b. *Hook up test-signal source:*
 - Connect the output of a leveled sine wave generator to a BNC female to BNC female adapter (see Figure 5-5).
 - Connect the BNC female to BNC female adapter to a BNC to probe tip adapter.

- Plug the probe tip from the probe on CH 1 into the BNC to probe tip adapter.

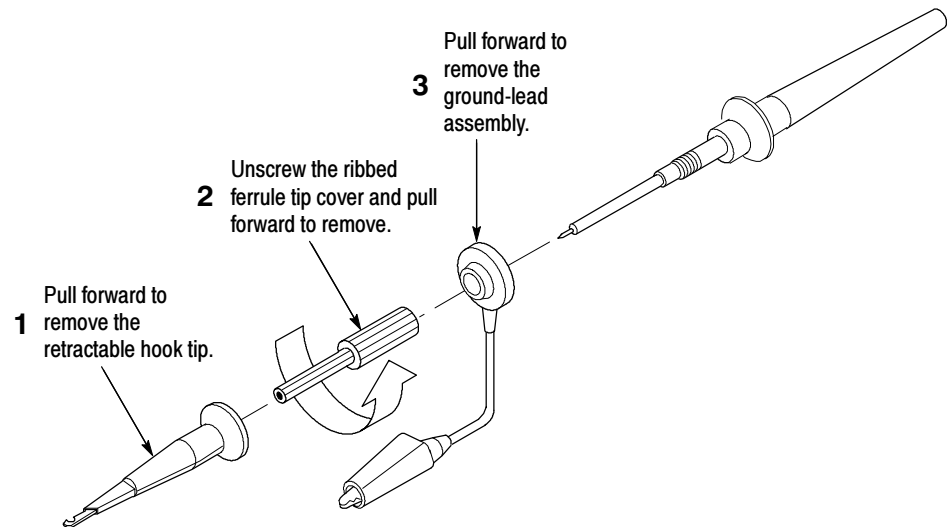

Figure 5-4: Exposing the Inner Probe Tip

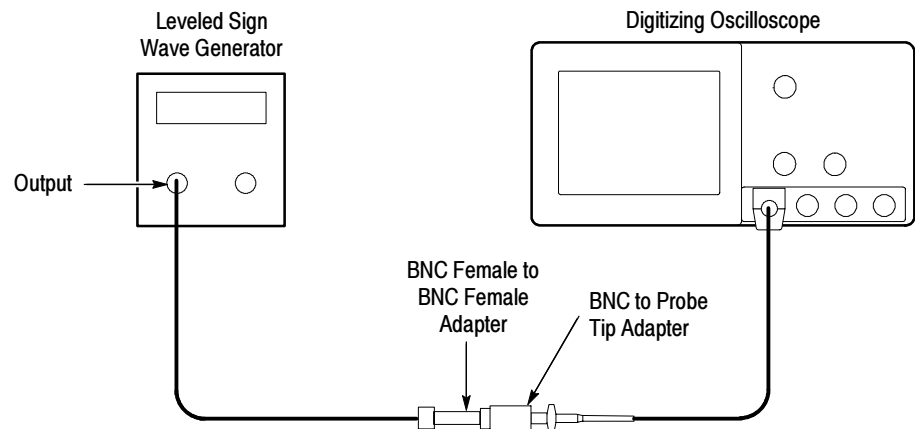

Figure 5-5: Initial Test Hookup

c. Initialize the oscilloscope:

- Press save/recall **SETUP**.
- Press the main-menu button **Recall Factory Setup**.
- Press the side-menu button **OK Confirm Factory Init**.

d. *Modify the initialized front-panel control settings:*

- Press **Autoset**.
- Set the vertical **SCALE** to 100 mV.
- Set the horizontal **SCALE** to 100 ns. (If you use a reference frequency other than 10 MHz, set the horizontal **SCALE** to display 5 to 7 cycles of the waveform.)
- Press **SHIFT**. Then press **ACQUIRE MENU**.
- Press the main-menu button **Mode**. Then press the side-menu button **Hi Res**.
- Press **MEASURE**.
- Press the main-menu button **Hi-Low Setup**. Then press the side-menu button **Min-Max**.
- Press the main-menu button **Select Measurement for Ch1**.
- Repeatedly press the side-menu button **-more-** until **Pk-Pk** appears in the side menu. Press the side-menu button **Pk-Pk**.
- Press **CLEAR MENU**.

2. *Confirm probe bandwidth:*

a. *Display and measure the test signal:*

- Monitor the **CH 1 Pk-Pk** readout while you set the output of the generator for a 600 mV (6 division), 10 MHz or less reference signal.
- (TDS 420A Only) Set the horizontal **SCALE** to 2 ns and set the frequency of the generator to 200 MHz.
- (TDS 430A and TDS 460A Only) Set the horizontal **SCALE** to 1 ns and set the frequency of the generator to 400 MHz.
- Read the measurement results at the CH 1 Pk-Pk readout on screen.

b. *Check against limits:* CHECK that the **CH 1 Pk-Pk** readout is greater than or equal to 420 mV.

3. *Disconnect the hookup:*

- a. Unplug the probe from the BNC to probe tip adapter.
- b. If substep 2b was passed, the probe adjustment is finished. Reverse the instructions in Figure 5-4, page 5-13, to reinstall the retractable hook probe tip.

- c. If substep 2b was *not* passed, leave the probe tip exposed. Remove the probe from CH 1 and go on to the next procedure *Adjust the Probe High-Frequency Response*.

Adjust the Probe — High Frequency Response

Do not perform this procedure until you have first completed the procedures *Compensate the Probe* and *Measure Probe Bandwidth* on pages 5-10 and 5-12, respectively.

Do not perform this procedure if you have successfully completed *Measure the Probe Bandwidth*. Probe adjustment is complete.

Equipment Required	<p>One pulse generator (Item 15)</p> <p>One pulse generator head (Item 16)</p> <p>One 50 Ω precision cable (Item 8)</p> <p>One BNC female to BNC female adapter (Item 2)</p> <p>One 50 Ω BNC to probe adapter (Item 3)</p> <p>One P6138A 10X probe (Item 12)</p> <p>One 10X attenuator (Item 5)</p> <p>One probe adjustment tool (included with the P6138A probe accessories).</p>
---------------------------	--

1. Install the test hookup and preset the oscilloscope controls:

a. Access Inner Probe Tip and Adjustment Ports:

- The probe tip should be exposed from the procedure *Measure Probe Bandwidth*. If not, follow the instructions in Figure 5-4 to expose the probe tip.
- Follow the instructions in Figure 5-6 to remove the probe body covers.

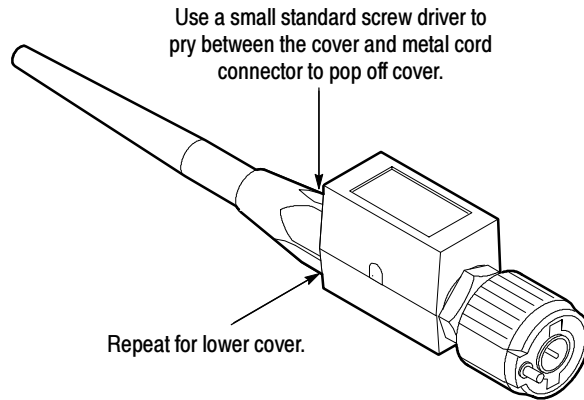

Figure 5-6: Exposing the Probe Body

b. Hook up test-signal source:

- Connect the high-amplitude output of a pulse generator, through a 50 Ω precision cable to the input of the pulse generator head (see Figure 5-7).
- Connect the output of the pulse generator head through a 10X attenuator to CH 1.
- Set the triggering level of the pulse generator head to minimum.

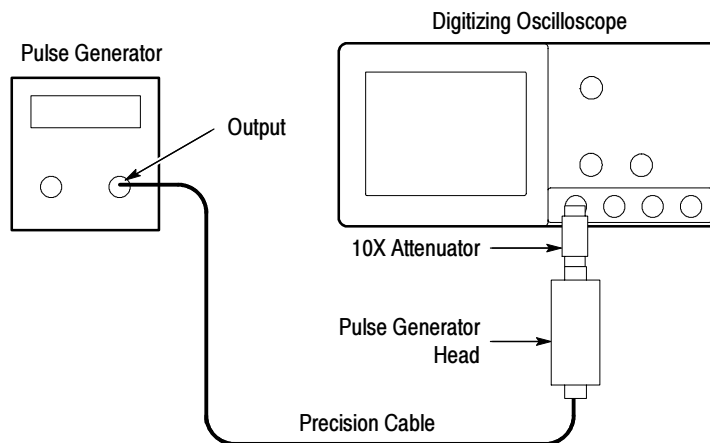

Figure 5-7: Initial Test Hookup

c. Initialize the oscilloscope:

- Press save/recall **SETUP**.

- Press the main-menu button **Recall Factory Setup**.
 - Press the side-menu button **OK Confirm Factory Init**.
- d. *Modify the initialized front-panel control settings:*
- Set vertical **SCALE** to 5 mV.
 - Press **VERTICAL MENU**. Then press the main-menu button **Coupling**. Press the side-menu button **Ω** to toggle to 50 Ω coupling.
 - Press **SHIFT**. Then press **ACQUIRE MENU**.
 - Press the main-menu button **Mode**. Then press the side-menu button **Hi Res**.
 - Press **CLEAR MENU**.
2. *Adjust the Probe:*
- a. *Display and store the reference signal:*
- Set the high-amplitude output of the generator for 60 to 100 V *at the input to the pulse generator head* (see Figure 5-8).
 - Advance the triggering level of the pulse generator head until a five to six division square wave appears on screen.
 - Push **SET LEVEL TO 50%** as required to trigger the signal.
 - Advance the horizontal **SCALE** to 5 ns.
 - Press **HORIZONTAL MENU**.
 - Press the main-menu button **Trigger Position**; and press the side-menu button **10%**.
 - Push **SHIFT**. Then press **SAVE WAVEFORM**.
 - Press the main-menu button **Save Waveform**. Then press the side-menu button **To Ref 1**.

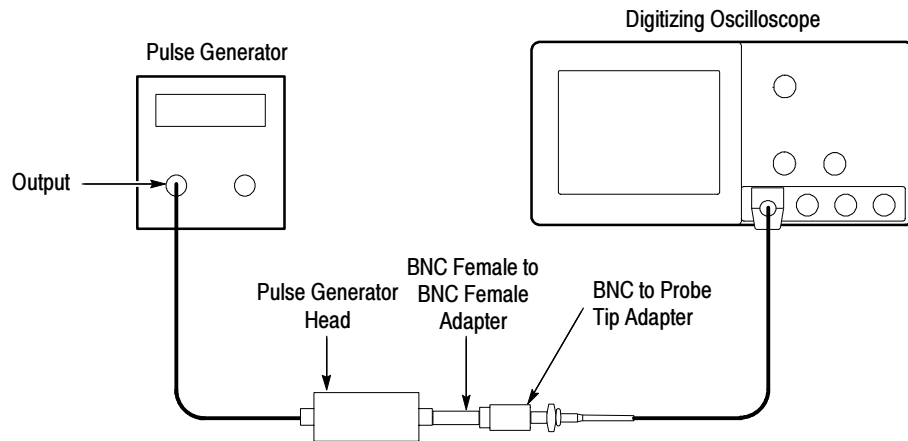

Figure 5-8: Probe Test Hookup

- Press **MORE**. Then push the main-menu button **Ref 1**.
- b. *Display the test signal:*
- Disconnect the pulse generator head at CH 1 and remove the 10X attenuator.
 - Connect the output of the pulse generator head through a BNC female to BNC female adapter to a BNC to probe tip adapter.
 - Install the probe on CH 1.
 - Plug the probe tip from the probe into the BNC to probe tip adapter.
 - Press the main-menu button **Coupling**. Then press the side-menu button Ω to toggle to 1 M Ω coupling.
 - Press **HORIZONTAL MENU**.
 - Press the main-menu button **Trigger Position**; press the side-menu button **10%**.
- c. *Make the adjustments:*
- Locate the various adjustments in Figure 5-9.
 - Manually adjust the front-corner response of the probe to best match the response of the Ref 1 waveform. Note that it is more important to match the response during the first 5 ns than during the entire first 20 ns the adjustments affect.
 - See Figure 5-10 to see what areas on the front corner that the various adjustments affect.

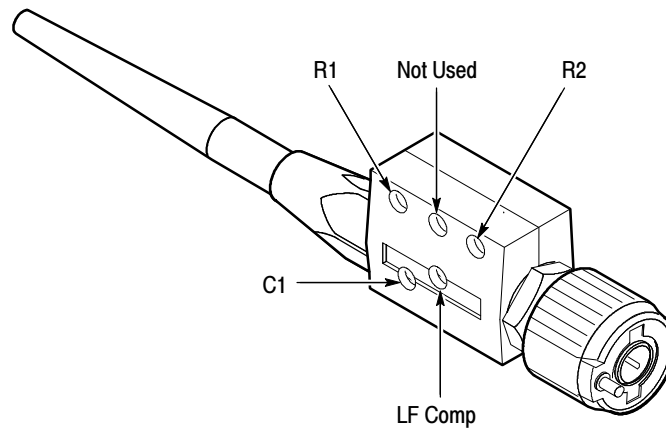

Figure 5-9: Locations of Probe Adjustments

d. Recheck Probe Bandwidth:

- Redo the procedure *Measure the Probe Bandwidth* to check if the probe now meets its bandwidth requirement.
- If bandwidth is met, adjustment is complete. Skip to step 3.
- If bandwidth is *not* met, redo this procedure, increasing front corner overshoot slightly relative to the stored waveform.
- Repeat this step (d) until bandwidth is met.

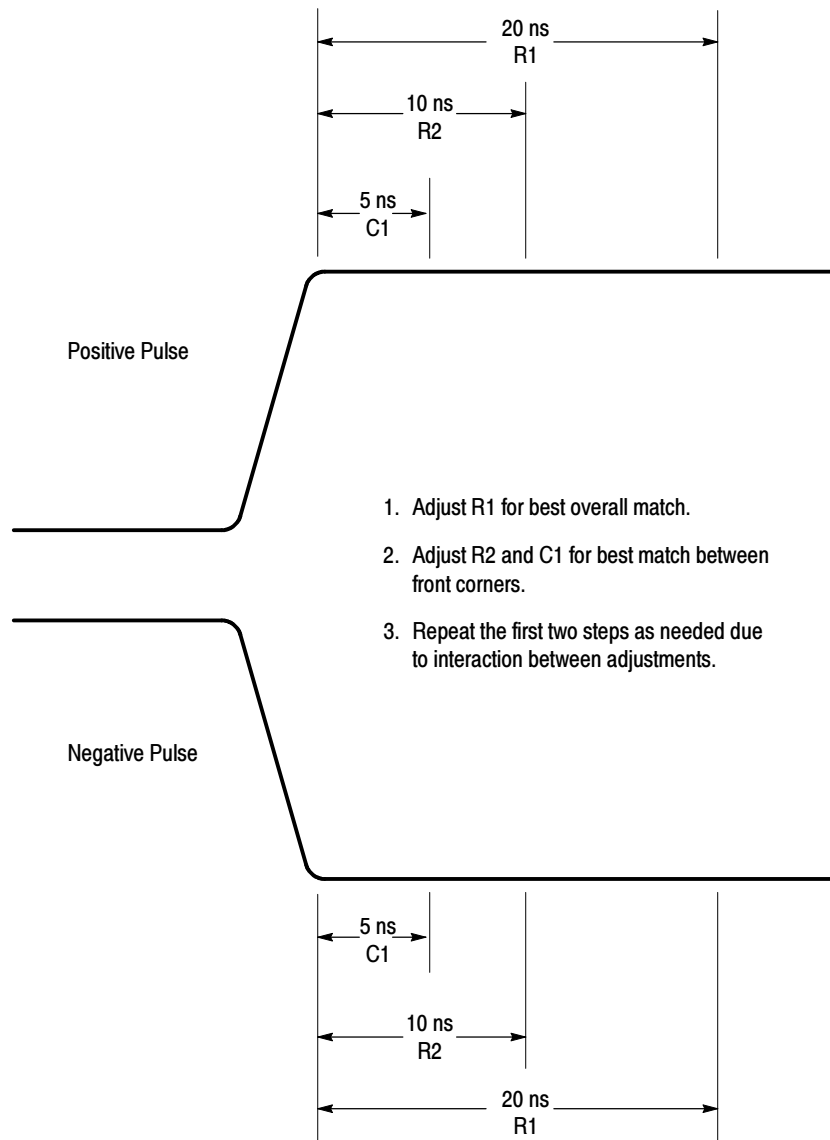

Figure 5-10: Adjustments vs. Front-Corner Response

3. *Disconnect the hookup:* Unplug the probe from the BNC to probe tip adapter. Reverse the instructions in Figure 5-4, page 5-13, to reinstall the retractable probe tip.

Monitor Assembly Adjustment



WARNING. High voltages are accessible on the A26 Monitor assembly. Do not touch the circuit board if the power is applied. Do not touch the CRT anode button even if the power cord is removed. Wear safety glasses when working with the CRT.

Do not do this procedure when performing a routine adjustment. Only do this procedure if the display on the monitor assembly has become unsatisfactory. See *Complete Adjustment* on page 5-2.



CAUTION. Static electricity can damage this circuitry. When standing the CRT on its front panel place it on a clean padded surface.

The equipment required to do this procedure is listed in Table 5-3.

Equipment Required	One J17 Photometer with a J1803 Luminance Probe (Item 17) One monitor adjustment tool (Item 4)
-------------------------------	---

1. *Access the inside of the oscilloscope:* See the *Removal and Installation Procedures* starting on page 6-9 to remove the cabinet.
2. *Adjust the vertical and horizontal sync:*
 - a. If the display rolls vertically adjust V. SYNC (R453) to the center of the stable display range. (See Figure 5-11.)
 - b. If diagonal lines are present on the display adjust H. SYNC (R473) to the center of the stable display range.

3. Adjust the display brightness:

a. Display the Circle test pattern:

- Disconnect the power plug from the oscilloscope.
- Set the DIP switch (S1), located near the front of the A03 CPU board, as follows:

Switch No.	1	2	3	4	5	6	7	8
Open						X	X	
Closed	X	X	X	X	X			X

- Reconnect the power plug to the oscilloscope.
- For instrument serial numbers B079999 and below reconnect the power plug and ensure the power switch is in the on position.
- Allow 15 to 20 minutes for the oscilloscope to warm up.
- Press **SHIFT** and **UTILITY**.
- Repeatedly press the main-menu button **System** until **Diag/Err** is highlighted in the pop up menu.
- Repeatedly press the main-menu button **Area** until **Display** is highlighted in the pop up menu.
- Repeatedly press the side-menu button **-more-** until **Circle** appears in the side menu. Push **Circle**.
- Press the main-menu button **EXECUTE**. Then press the side-menu button **Ok Confirm Run Test**.

b. Make the brightness adjustment:

- Locate R482 (BRITE) (see Figure 5-11).
- Adjust R482 until the background raster lines in the 5% luminance patch (see Figure 5-12 on page 5-24) disappear while the lines in the 10% luminance patch are visible.

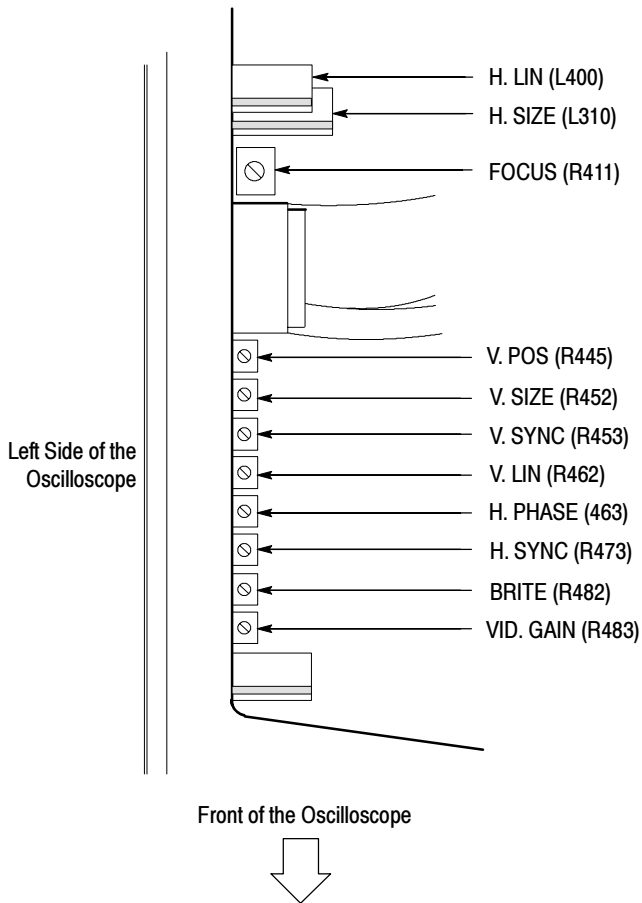

Figure 5- 11: Monitor Adjustment Locations

4. Adjust the display contrast:

a. Display the White Box test pattern:

- Press the center main-menu button to display the main-menu.
- Press the main-menu button **Tests**.
- Repeatedly press the side-menu button **-more-** until **White Box** appears in the side menu. Push **White Box**.
- Press the main-menu button **EXECUTE**. Then press the side-menu button **Ok Confirm Run Test**.

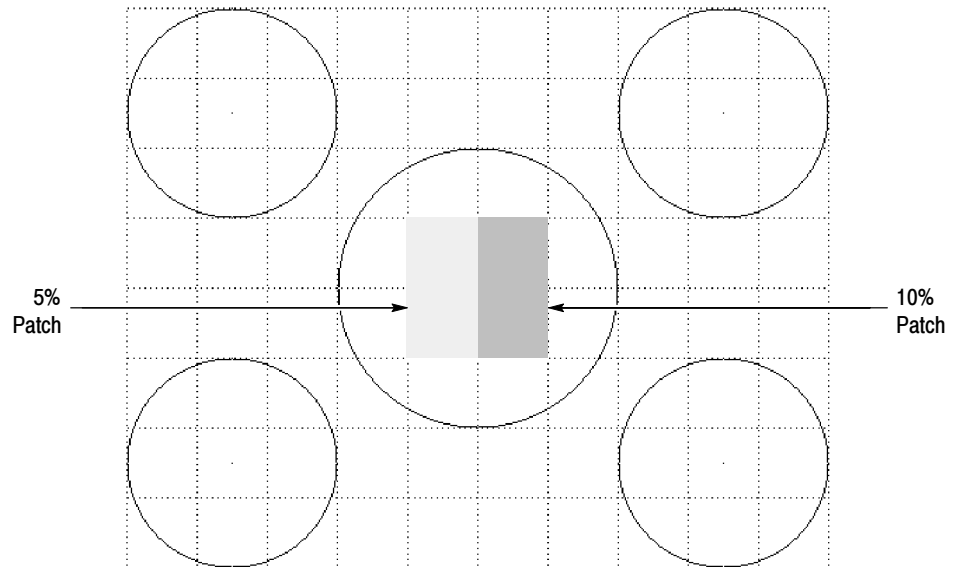

Figure 5-12: Five and Ten Percent Luminance Patches

b. Make the contrast adjustment:

- Locate R483 (VID. GAIN) on the A26 Monitor assembly (see Figure 5-11).
- Monitor the luminance at center screen using a J17 photometer and a luminance probe.
- Adjust R483 (VID. GAIN) for a reading of 100 foot-lamberts (343 candelas).
- If R483 needed a large adjustment, perform the brightness adjustment again.

5. Adjust the display focus:

a. Display the Composite test pattern:

- Press the center main-menu button to display the main-menu.
- Press the main-menu button **Tests**.
- Repeatedly press the side-menu button **-more-** until **Composite** appears in the side menu. Push **Composite**.
- Press the main-menu button **EXECUTE**. Then press the side-menu button **Ok Confirm Run Test**.

b. Make the focus adjustment:

- Locate R411 (FOCUS) (see Figure 5-11).
- Adjust R411 for best overall focusing at all four corners and at the center of the screen (see Figure 5-13).

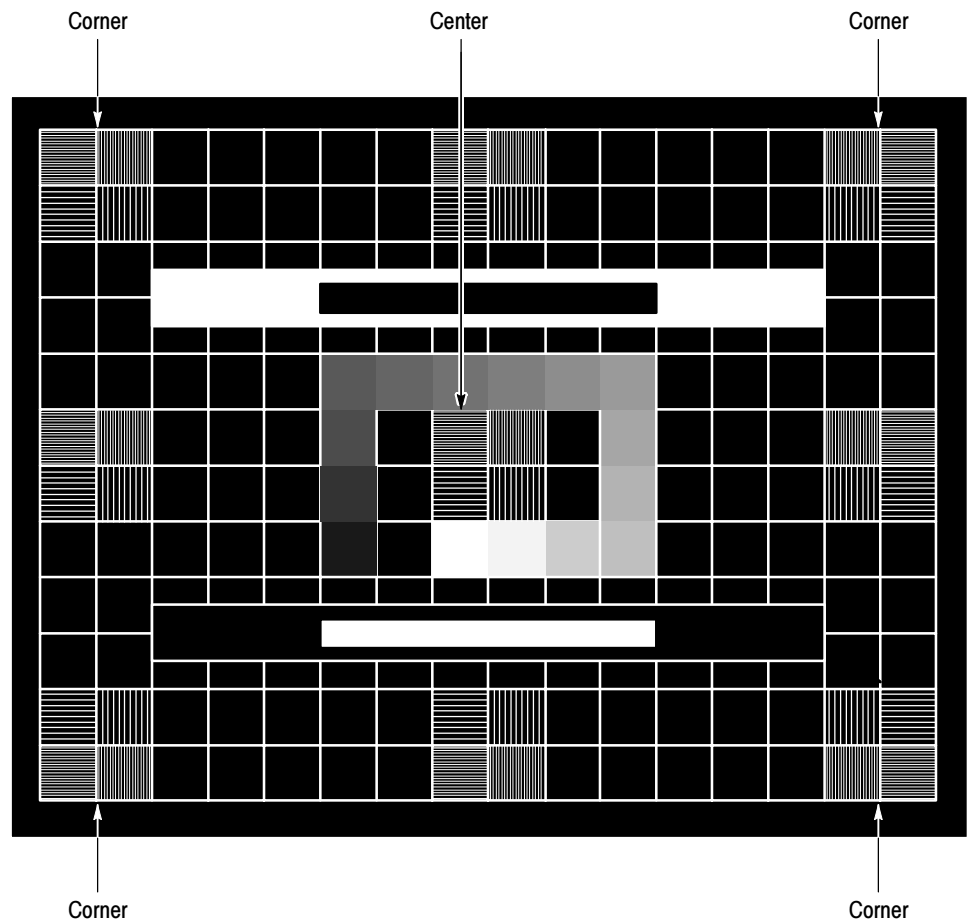

Figure 5-13: Composite Pattern for Focusing

6. Restore the oscilloscope to normal operation:

- a. Restore the dip switch to the settings that follow:**

Switch No.	1	2	3	4	5	6	7	8
Open								
Closed	X	X	X	X	X	X	X	X

- b.** Power off the oscilloscope.
- c.** See the *Removal and Installation Procedures* starting on page 6-9 to reinstall the cabinet and other modules removed in step 1.

Maintenance

This chapter contains the information needed to do periodic and corrective maintenance on the TDS 420A, TDS 430A, & TDS 460A Digitizing Oscilloscopes. Specifically, the following sections are included:

- *Preparation* — General information on preventing damage to internal modules when doing maintenance.
- *Inspection and Cleaning* — Information and procedures for inspecting the oscilloscope and cleaning its external and internal modules.
- *Removal and Installation Procedures* — Procedures for the removal of defective modules and replacement of new or repaired modules. Also included is a procedure for disassembly of the oscilloscope for cleaning.
- *Troubleshooting* — Information for isolating failed modules. Included are instructions for operating the internal diagnostic routines and troubleshooting trees. Most of the trees make use of these internal diagnostic routines to speed fault isolation to a module.

Service personnel must be prepared to safely service the oscilloscope. This manual is for qualified service personnel only. Read the *General Safety Summary* and the *Service Safety Summary* at the front of this manual. If you are unfamiliar with the operation of this oscilloscope, read *Operating Information* (Chapter 2) before servicing the oscilloscope. To prevent electro-static damage (ESD), read *Preventing ESD*, on page 6-2, before servicing the oscilloscope.

Related Maintenance Procedures

The following chapters contain information and procedures related to doing maintenance.

- Chapter 2, *Operating Information*, covers instructions useful when operating the oscilloscope in order to troubleshoot it. The chapter also details the service strategy and lists options for obtaining maintenance service and for replacing failed modules.
- Chapter 3, *Theory of Operation*, contains a circuit description at the module, or block, level.
- Chapter 4, *Performance Verification*, contains procedures that are useful in isolating problems to modules by testing oscilloscope performance.

- Chapter 5, *Adjustment Procedures*, addresses after repair adjustment and the interval between periodic adjustments. It contains a procedure for adjusting the internal circuits of the oscilloscope.
- Chapter 9, *Diagrams*, contains a block diagram using individual modules as blocks and an interconnection diagram showing connections between the modules.
- Chapter 10, *Mechanical Parts List*, lists all field replaceable modules by part number.

Preparation

This section gives general information on preventing damage to internal modules when doing maintenance.



CAUTION. *Static discharge can damage any semiconductor component in this oscilloscope.*

Preventing ESD

When performing any service which requires internal access to the oscilloscope, adhere to the following precautions to avoid damaging internal modules and their components due to electrostatic discharge (ESD).

1. Minimize handling of static-sensitive modules.
2. Transport and store static-sensitive modules in their static protected containers. Label any package that contains static-sensitive modules.
3. Discharge the static voltage from your body by wearing a grounded antistatic wrist strap while handling these modules. Do service of static-sensitive modules only at a static-free work station.
4. Do not remove the oscilloscope cabinet unless you have met precaution number 3, above. Consider all internal modules static-sensitive.
5. Nothing capable of generating or holding a static charge should be allowed on the work station surface.
6. Handle circuit boards by their edges when possible.
7. Do not slide the modules over any surface.
8. Avoid handling modules in areas that have a floor or work-surface covering capable of generating a static charge.
9. Do not use high-velocity compressed air when cleaning dust from modules.

Susceptibility to ESD

Table 6-1 lists the relative susceptibility of various classes of semiconductors. Static voltages of 1 kV to 30 kV are common in unprotected environments.

Table 6-1: Relative Susceptibility to Static-Discharge Damage

Semiconductor Classes	Relative Susceptibility Levels¹
MOS or CMOS microcircuits or discrete circuits, or linear microcircuits with MOS inputs (most sensitive)	1
ECL	2
Schottky signal diodes	3
Schottky TTL	4
High-frequency bipolar transistors	5
JFET	6
Linear microcircuits	7
Low-power Schottky TTL	8
TTL (least sensitive)	9

¹ **Voltage equivalent for levels (voltage discharged from a 100 pF capacitor through resistance of 100 ohms):**

1 = 100 to 500 V	6 = 600 to 800 V
2 = 200 to 500 V	7 = 400 to 1000 V (est.)
3 = 250 V	8 = 900 V
4 = 500 V	9 = 1200 V
5 = 400 to 600 V	

Inspection and Cleaning

Inspection and Cleaning describes how to inspect for dirt and damage on, and how to clean the exterior and interior of, the TDS 420A, TDS 430A, & TDS 460A Digitizing Oscilloscopes. Inspection and cleaning are done as preventive maintenance. Preventive maintenance, when done regularly, may prevent oscilloscope malfunction and enhance its reliability.

Preventive maintenance consists of visually inspecting and cleaning the oscilloscope and using general care when operating it.

How often to do maintenance depends on the severity of the environment in which the oscilloscope is used. A proper time to perform preventive maintenance is just before oscilloscope adjustment.

General Care

The cabinet helps keep dust out of the oscilloscope, and it is a major component of the oscilloscope cooling system. The cabinet should normally be in place when operating the oscilloscope. The front cover protects the front panel and display from dust and damage. Install the front cover when storing or transporting the oscilloscope.

Inspection and Cleaning Procedures

Inspect and clean the oscilloscope as often as operating conditions require. The collection of dirt on components inside can cause them to overheat and break-down. (Dirt acts as an insulating blanket, preventing efficient heat dissipation.) Dirt also provides an electrical conduction path that could cause an oscilloscope failure, especially under high-humidity conditions.



CAUTION. *Avoid the use of chemical cleaning agents which might damage the plastics used in this oscilloscope. Use only deionized water when cleaning the menu buttons or front-panel buttons. Use a 75% isopropyl alcohol solution as a cleaner and rinse with deionized water. Before using any other type of cleaner, consult your Tektronix Service Center or representative.*

Avoid the use of high pressure compressed air when cleaning dust from the interior of this instrument. (High pressure air can cause ESD.) Instead, use low pressure compressed air (about 9 psi).

Inspection — Exterior. Using Table 6-2 as a guide, inspect the outside of the oscilloscope for damage, wear, and missing parts. Oscilloscopes that appear to have been dropped or otherwise abused should be checked thoroughly to verify correct operation and performance. Immediately repair defects that could cause personal injury or lead to further damage to the oscilloscope.

Table 6-2: External Inspection Check List

Item	Inspect For	Repair Action
Cabinet, front panel, and cover	Cracks, scratches, deformations, damaged hardware or gaskets.	Replace defective module.
Front-panel knobs	Missing, damaged, or loose knobs.	Repair or replace missing or defective knobs.
Connectors	Broken shells, cracked insulation, and deformed contacts. Dirt in connectors.	Replace defective modules. Clear or wash out dirt.
Carrying handle, bail, cabinet feet.	Correct operation.	Replace defective module.
Accessories	Missing items or parts of items, bent pins, broken or frayed cables, and damaged connectors.	Replace damaged or missing items, frayed cables, and defective modules.

Cleaning Procedure — Exterior. Use the following procedure to clean the exterior of the oscilloscope.



CAUTION. To prevent getting moisture inside the oscilloscope during external cleaning, use only enough liquid to dampen the cloth or applicator.

1. Remove loose dust on the outside of the oscilloscope with a lint free cloth.
2. Remove remaining dirt with a lint free cloth dampened in a general purpose detergent-and-water solution. Do not use abrasive cleaners.
3. Clean the monitor screen with a lint-free cloth dampened with either isopropyl alcohol or, preferably, a gentle, general purpose detergent-and-water solution.

Inspection — Interior. To access the inside of the oscilloscope for inspection and cleaning, refer to the *Removal and Installation Procedures* on page 6-9.

Inspect the internal portions of the oscilloscope for damage and wear using Table 6-3 as a guide. Defects found should be repaired immediately.

If any electrical module is replaced, check Table 5-1 on page 5-3 to see if it is necessary to adjust the oscilloscope.



CAUTION. To prevent damage from electrical arcing, ensure that circuit boards and components are dry before applying power to the oscilloscope.

Table 6-3: Internal Inspection Check List

Item	Inspect For	Repair Action
Circuit boards	Loose, broken, or corroded solder connections. Burned circuit boards. Burned, broken, or cracked circuit-run plating.	Remove failed module and replace with a fresh module.
Resistors	Burned, cracked, broken, blistered condition.	Remove the module with the faulty resistor and replace it with a fresh module.
Solder connections	Cold solder or rosin joints.	Resolder joint and clean with isopropyl alcohol.
Capacitors	Damaged or leaking cases. Corroded solder on leads or terminals.	Remove the module with the faulty capacitor and replace it with a fresh module from the factory.
Semiconductors	Loosely inserted in sockets. Distorted pins.	Firmly seat loose semiconductors. Remove devices that have distorted pins. Carefully straighten pins (as required to fit the socket), using long-nose pliers, and reinsert firmly. Ensure that straightening action does not crack pins, causing them to break off.
Wiring and cables	Loose plugs or connectors. Burned, broken, or frayed wiring.	Firmly seat connectors. Repair or replace modules with defective wires or cables.
Chassis	Dents, deformations.	Straighten, repair, or replace chassis.

Cleaning Procedure — Interior. Use the following procedure to clean the interior of the oscilloscope.

STOP. *If, after doing steps 1 and 2, a module is clean upon inspection, skip the remaining steps.*

1. Blow off dust with dry, low-pressure, deionized air (approximately 9 psi).
2. Remove any remaining dust with a lint free cloth dampened in isopropyl alcohol (75% solution) and rinse with warm deionized water. (A cotton-tipped applicator is useful for cleaning in narrow spaces and on circuit boards.)

3. If steps 1 and 2 do not remove all the dust or dirt, the oscilloscope may be spray washed using a solution of 75% isopropyl alcohol by doing steps 4 through 8.
4. Gain access to the parts to be cleaned by removing easily accessible shields and panels (see *Removal and Installation Procedures* on page 6-9).
5. Spray wash dirty parts with the isopropyl alcohol and wait 60 seconds for the majority of the alcohol to evaporate.
6. Use 49° to 60° C (120° to 140° F) deionized water to thoroughly rinse the parts.
7. Dry all parts with low-pressure, deionized air.
8. Dry all components and assemblies in an oven or drying compartment using 52° to 65° C (125° to 150° F) circulating air.

Lubrication. There is no periodic lubrication required for this oscilloscope.

Removal and Installation Procedures

This section contains procedures for removal and installation of all mechanical and electrical modules. Any electrical or mechanical module, assembly, or part listed in Chapter 10 of this manual is a module.

Preparation — Please Read



WARNING. Before doing this or any other procedure in this manual, read the Safety Summary found at the beginning of this manual. Also, to prevent possible injury to service personnel or damage to oscilloscope components, read Before Servicing, page xvi, Supplying Operating Power, page 2-1, and Preventing ESD in this chapter.

This section contains the following information:

- This preparatory information that you need to properly do the procedures that follow.
- A list of equipment required to remove all modules.
- Procedures for removal and reinstallation of the electrical and mechanical modules.
- A disassembly procedure for removal of all the major modules from the oscilloscope at one time and for reassembly of those modules into the oscilloscope. A complete disassembly is normally only done when completely cleaning the oscilloscope. (Instructions for doing the actual cleaning are found under *Inspection and Cleaning* beginning on page 6-4.)
- Three module locator diagrams for finding all the modules in this oscilloscope.



WARNING. Before doing any procedure in this section, disconnect the power cord from the line voltage source. Failure to do so could cause serious injury or death.

List of Modules Chapter 10 lists all modules.

Cable Removal Usually cables are partially or completely removed as in the course of removing a module they plug into. However, all field replaceable cables are modules and can be replaced by doing the *Access Procedure*. Figure 6-4, on page 6-22, shows the cables and their routing.

General Instructions ***STOP. READ THESE GENERAL INSTRUCTIONS BEFORE REMOVING A MODULE.***

First read over the Summary of Procedures that follows to understand how the procedures are grouped. Then read Equipment Required for a list of the tools needed to remove and install modules in this oscilloscope.

Reference Figure 6-1 on page 6-11. Procedures refer to “front,” “rear,” “top,” etc. of the oscilloscope; note from the figure which sides are referenced.

If you are disassembling this oscilloscope for cleaning, go to the procedure Disassembly for Cleaning on page 6-71.

If you are removing a module for service, begin by doing the procedure Access Procedure (page 6-13). By following the instructions in that procedure, you remove the module to be serviced while removing the minimum number of additional modules.

Summary of Procedures The procedures are described in the order in which they appear in this section. In addition, you can look up any procedure for removal and reinstallation of any module in the *Table of Contents* of this manual.

- The *Access Procedure* on page 6-13 first directs you to the procedure(s) that remove any modules that must be removed to access the module to be serviced. It then directs you to the procedure to remove that module.
- *Procedures for Module Removal and Installation* on page 6-23 are the procedures for removing modules. *These procedures assume you have done the access procedure.*
- *Disassembly for Cleaning* on page 6-71 is a procedure, based on the module removal procedures just described, that removes all modules for cleaning. Instructions for cleaning are found in *Inspection and Cleaning* beginning on page 6-4. *The Disassembly for Cleaning procedure does not use the access procedure.*

NOTE. Read the cleaning procedure before disassembling the oscilloscope for cleaning.

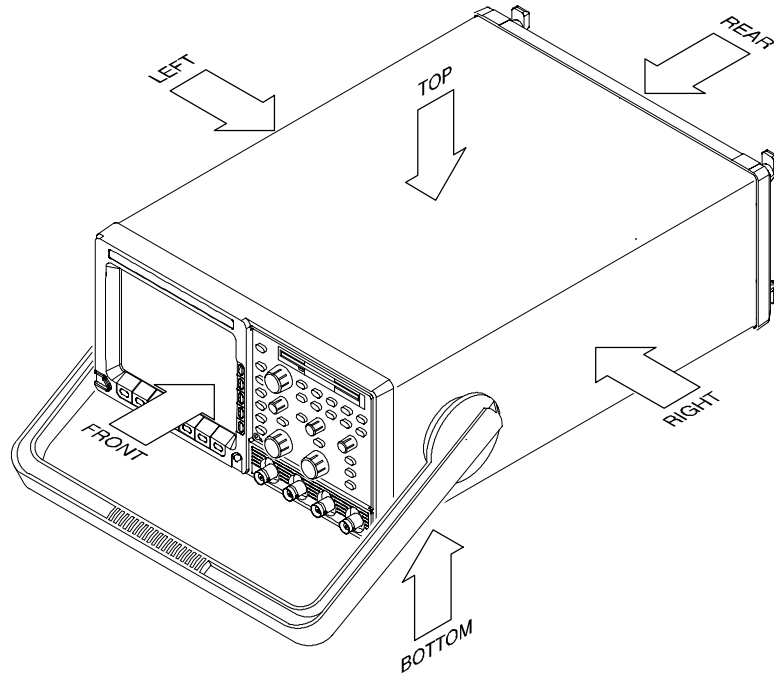

Figure 6-1: Oscilloscope orientation

Equipment Required. Table 6-4 lists the tools required to completely disassemble the oscilloscope into its modules. The tools required to remove an individual module are listed in the first step of its procedure.

All the tools are standard tools readily available from tool suppliers.

Table 6-4: Tools Required for Module Removal

Item No.	Name	Description
1	Screwdriver handle	Accepts Torx®-driver bits.
2	T-15 Torx tip	Torx®-driver bit for T-15 size screw heads.
3	T-20 Torx tip	Torx®-driver bit for T-20 size screw heads. Used only for removal of the cabinet handle.
4	Torque wrench	8 inch-lbs torque; accepts Torx®-driver bits.
5	Flat-bladed screwdriver	Screwdriver for removing standard-headed screws.
6	Pozidriv screwdriver	Used for removing disk drive.
7	Needle-Nose Pliers	Standard tool. Used for removing EMI gaskets.
8	Duck-bill pliers	4 inch. Used for removing the low voltage power supply.
9	Nutdriver, $\frac{5}{16}$ inch	Used for removing earth ground cables.
10	Angle-Tip Tweezers	Used for knob and shaft removal.
11	Flat-bladed spudger	A probe-like tool with a tip like a flat bladed screwdriver. Used to press EMI gaskets into place.
12	Soldering Iron	15 watt. Used for removal of some cables and the acquisition assembly.
13	Slip-jaw pliers	Used for removing the front feet from the cabinet.
14	Front cover	This optional accessory protects the front of the oscilloscope when positioned face down in the removal procedures.

Access Procedure

Begin with this procedure when you have identified a module to be removed for service and have read *General Instructions* found earlier in this section.

1. *Locate module to be removed:*
 - a. Find the module to be removed in the module locator diagrams, figures 6-2, 6-3, and 6-4 (pages 6-16, 6-19, and 6-22, respectively).
 - b. Note the number of the figure in which you found the module and the module name.
2. *Access the module:*
 - a. If you have located the module to be replaced in Figure 6-2, do the following subparts:
 - Go to Table 6-5 on page 6-15.
 - Find the procedure that includes the name of the module noted in step 1.
 - Perform the access instructions listed for the procedure found to access and remove the module.
 - Skip to the end of this procedure (step 3) for reinstallation instructions.
 - b. If you have found the module to be removed in either Figure 6-3 or Figure 6-4, cabinet removal is required:
 - First do *Line Fuse and Line Cord* on page 6-26, removing only the line cord.
 - Then do *Front Cover, Rear Cover, Cabinet, Rear EMI Gasket, and Cabinet Handle and Feet* on page 6-27, removing only the rear cover and cabinet.
 - Continue with step 2c.
 - c. If you have located the module to be replaced in Figure 6-3, do the following subparts:
 - Go to Table 6-6 on page 6-17.
 - Find the procedure that includes the name of the module noted in step 1.
 - Perform the access instructions listed for the procedure found to access and remove the module.

- Skip to the end of this procedure (step 3) for reinstallation instructions.
- d. If you have located the module to be replaced in Figure 6-4, you are removing one of the field replaceable cables. Do the following subparts:
- Go to Table 6-7 on page 6-20.
 - Find the procedure that includes the name of the cable noted in step 1.
 - Perform the instructions listed in the table for that procedure to access and remove the cable.
 - Follow the instructions listed in the table for the reinstallation of the cable. Then exit this procedure.
3. *Reinstall all modules removed:* Read the instructions found at the end of the procedure that removes the module to be serviced — they guide you in reinstalling all modules removed. All procedures are found under *Procedures for Module Removal and Installation* on page 6-23, which follows this access procedure.

Table 6-5: Access Instructions for Modules in Figure 6-2

Procedure Including Module to be Removed	Page No	Access Instructions
1 <i>Front-Panel Knobs and Shafts</i>	6-23	<ol style="list-style-type: none"> 1 Do only the procedure listed at left. 2 Remove only the module you want to service.
2 <i>Line Fuse and Line Cord</i>	6-26	<ol style="list-style-type: none"> 1 Do only the procedure listed at left. 2 Remove only the module you want to service.
3 <i>Front Cover, Rear Cover, Cabinet, Rear EMI Gasket, and Cabinet Handle and Feet</i>	6-27	<ol style="list-style-type: none"> 1 Do <i>Line Fuse and Line Cord</i> removing only the line cord. 2 Do the procedure listed at left, removing only the module(s) you want to service.
4 <i>Trim Ring, Menu Elastomer, Menu Buttons, and Front EMI Gaskets</i>	6-31	<ol style="list-style-type: none"> 1 Do <i>Line Fuse and Line Cord</i> removing only the line cord. 2 Do <i>Front Cover, Rear Cover, Cabinet, Rear EMI Gasket, and Cabinet Handle and Feet</i>, removing only the rear cover and cabinet. 3 Do the procedure listed at left, removing all modules including the module(s) you want to service.
5 <i>Disk Drive</i>	6-34	<ol style="list-style-type: none"> 1 Do <i>Line Fuse and Line Cord</i> removing only the line cord. 2 Do the <i>Front Cover, Rear Cover, Cabinet, Rear EMI Gasket, and Cabinet Handle and Feet</i>. 3 Do the procedure listed at left to remove the module.
6 <i>A06 Front-Panel Assembly, ESD Shield, and Menu Flex and Probe Code Flex Circuits</i>	6-35	<ol style="list-style-type: none"> 1 Do <i>Disk Drive</i>. 2 Do <i>Trim Ring, Menu Elastomer, Menu Buttons, and Front EMI Gaskets</i>. 3 Do the procedure listed at left, removing all modules including the module(s) you want to service. When doing the procedure listed at left, do <i>not</i> remove the menu flex circuit unless it is being replaced with a new module.

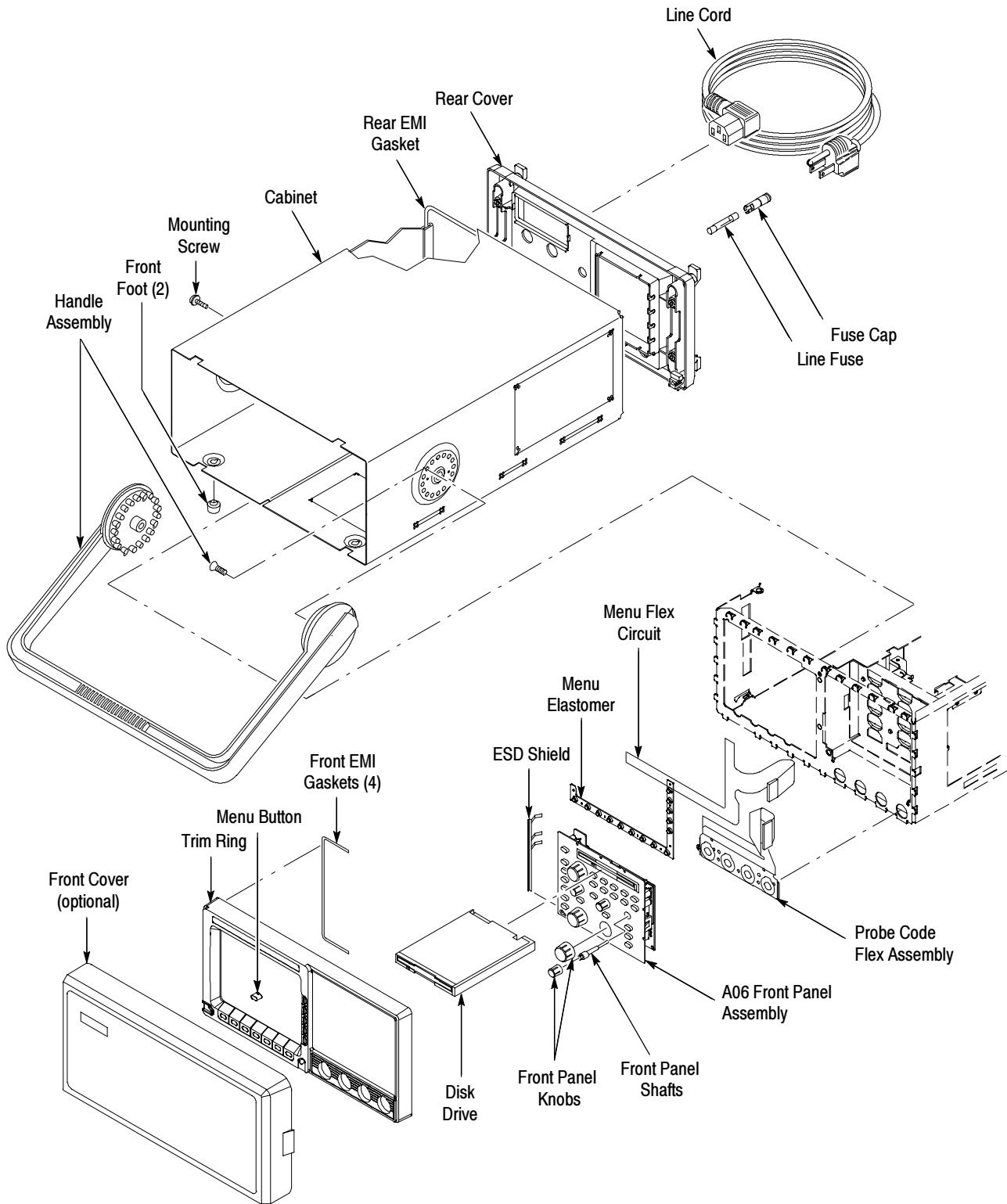

Figure 6-2: Cabinet and front-panel mounted modules

Table 6-6: Access Instructions for Modules in Figure 6-3

Procedure Including Module to be Removed	Page No	Access Instructions
1 <i>A05 Attenuator Assembly and Shield</i>	6-39	<ol style="list-style-type: none"> 1 Do <i>Trim Ring, Menu Elastomer, Menu Buttons, and Front EMI Gaskets</i> (page 6-31). 2 Do <i>A08 Jumper Board Assembly, D1 Bus, and Board Supports</i>, listed as procedure number 3 in this table. Remove only the A08 jumper board assembly. 3 Do <i>A06 Front-Panel Assembly, ESD Shield, and Menu Flex and Probe Code Flex Circuits</i> (page 6-35). Do not remove the menu flex circuit. 4 Do the procedure listed at left to remove the module.
2 <i>A26 Monitor Assembly</i>	6-41	<ol style="list-style-type: none"> 1 Do the procedure listed at left to remove the module.
3 <i>A08 Jumper Board Assembly, D1 Bus, and Board Supports</i>	6-44	<ol style="list-style-type: none"> 1 Do the procedure listed at left to remove the module.
4 <i>A03 CPU Assembly</i>	6-45	<ol style="list-style-type: none"> 1 Do <i>A08 Jumper Board Assembly, D1 Bus, and Board Supports</i>, removing only the board supports. 2 Do the procedure listed at left to remove the module.
5 <i>A02 Display Assembly</i>	6-47	<ol style="list-style-type: none"> 1 Do <i>A08 Jumper Board Assembly, D1 Bus, and Board Supports</i>. Do not remove the A08 jumper board assembly. 2 Do the procedure listed at left to remove the module.
6 <i>A09 DSP Assembly</i>	6-48	<ol style="list-style-type: none"> 1 Do <i>A08 Jumper Board Assembly, D1 Bus, and Board Supports</i>. Do not remove the A08 jumper board assembly. 2 Do the procedure listed at left to remove the module.
7 <i>A01 Backplane Assembly and its Mount</i>	6-50	<ol style="list-style-type: none"> 1 Do <i>A08 Jumper Board Assembly, D1 Bus, and Board Supports</i>. Do not remove the A08 jumper board assembly. 2 Do, in order, the procedures numbered 4-6 (inclusive) in this table. 3 Do the procedure listed at left to remove the module.
8 <i>Fan and Fan Mount</i>	6-63	<ol style="list-style-type: none"> 1 Do the procedure listed at left to remove the module.
9 <i>A25 Low Voltage Power Supply and its Mount</i>	6-57	<ol style="list-style-type: none"> 1 <i>Only</i> if removing the plastic mount that secures the Low Voltage Power Supply, do, in order, the procedures numbered 4-7 (inclusive) in this table. 2 Do procedure <i>Fan and Fan Mount</i>. Do not remove the fan mount. 3 Do the procedure listed at left to remove the module.
10 <i>A07 Auxiliary Power Supply</i>	6-67	<ol style="list-style-type: none"> 1 Do the procedure listed at left to remove the module.
11 <i>Line Filter</i>	6-65	<ol style="list-style-type: none"> 1 Do the procedure listed at left to remove the module.

Table 6-6: Access Instructions for Modules in Figure 6-3 (Cont.)

Procedure Including Module to be Removed	Page No	Access Instructions
12 <i>Back-Up Batteries</i>	6-53	1 Do the procedure listed at left to remove the module.
13 <i>A04 Acquisition Assembly</i>	6-69	1 Do <i>A08 Jumper Board Assembly, D1 Bus, and Board Supports</i> (see page 6-44). Do not remove the board supports.
		2 Do the procedure listed at left to remove the module.

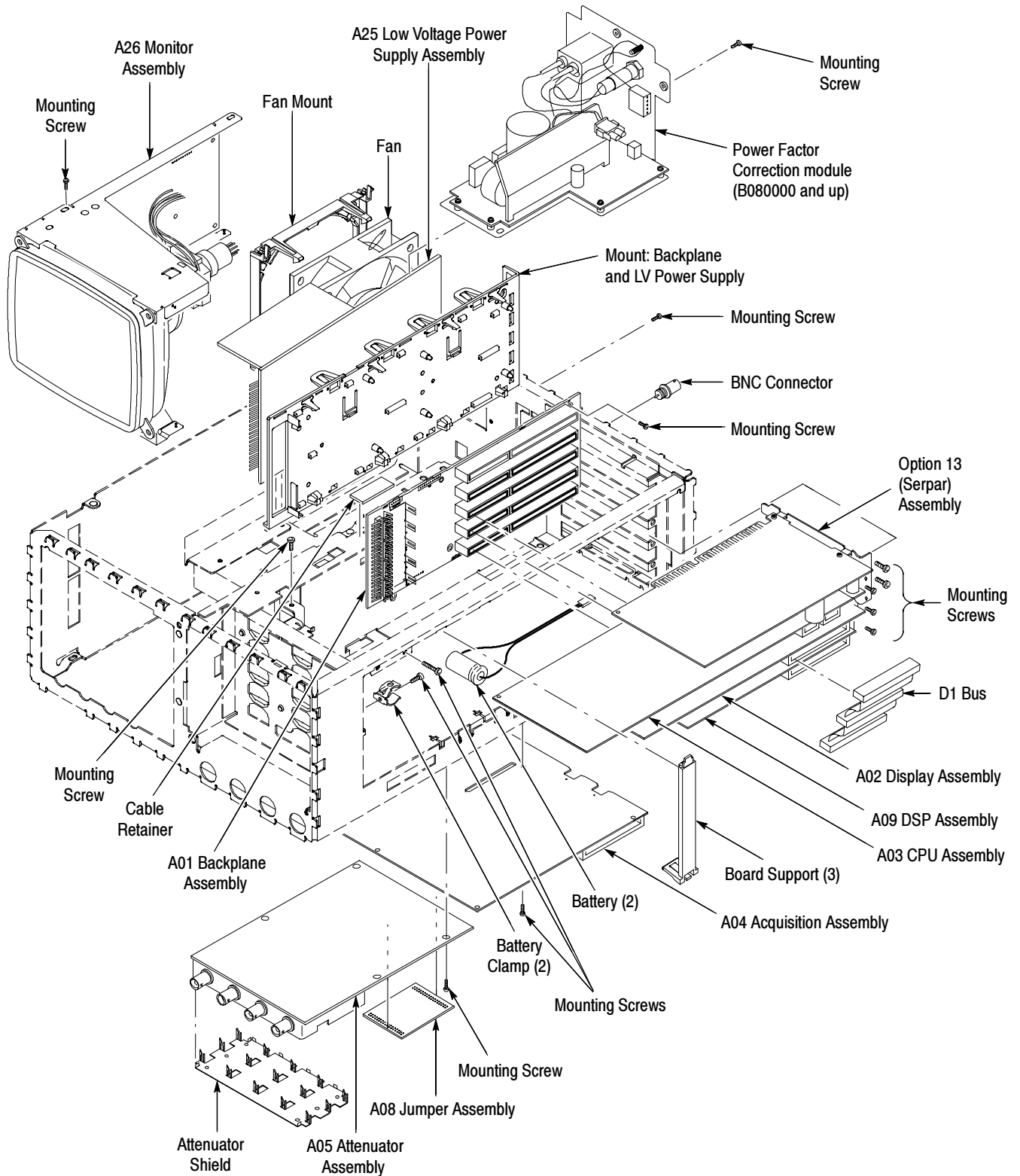

Figure 6-3: Internal modules

Table 6-7: Access (and Removal) Instructions for Cables in Figure 6-4

Name of Cable	Access and Removal Instructions
1 <i>Disk to CPU</i>	<ol style="list-style-type: none"> 1 Lift up on the latch at each side of both jacks. 2 Unplug the cable to be replaced from the disk drive and A03 CPU assemblies. See Figure 6-4 on page 6-22 for jack location. 3 Reverse these instructions to install the replacement cable.
2 <i>Backplane to Acquisition</i> <i>Backplane to Attenuator</i>	<ol style="list-style-type: none"> 1 Find the procedure <i>A01 Backplane Assembly and its Mount</i> in Table 6-6. 2 Follow the access instructions found there to access and remove the backplane assembly. 3 Unsolder the cable(s) to be replaced using a 15 watt soldering iron and remove it. 4 Reverse these instructions to install the replacement cable.
3 <i>Backplane to Front Panel</i> <i>CPU to Front Panel</i>	<ol style="list-style-type: none"> 1 Find the procedure <i>A06 Front-Panel Assembly, ESD Shield, and Menu Flex and Probe Code Flex Circuits</i> in Table 6-6. 2 Follow the access instructions found there to access and remove the front panel assembly. The cables plugged into that assembly are removed in the process. 3 Unplug the cable to be replaced from the backplane assembly. See Figure 6-4 for jack location. 4 Reverse these instructions to install the replacement cable.
4 <i>Backplane to Low Voltage Power Supply</i>	<ol style="list-style-type: none"> 1 Reach in from the top of the oscilloscope and unplug the cable at the jacks at the front of the backplane and low voltage power supply modules. 2 Reverse these instructions to install the replacement cable.
5 <i>Aux Supply to Line Filter</i> <i>Aux Supply to Low Voltage Power Supply</i>	<ol style="list-style-type: none"> 1 Find the procedure <i>A07 Auxiliary Power Supply</i> in Table 6-6. 2 Follow the access instructions found there to access and remove the auxiliary power supply assembly. 3 Unsolder the cable to be replaced using a 15 watt soldering iron and remove it from the auxiliary power supply. 4 Reverse these instructions to install the replacement cable.

Table 6-7: Access (and Removal) Instructions for Cables in Figure 6-4 (Cont.)

Name of Cable	Access and Removal Instructions
6 <i>Aux Supply to Low Voltage Power Supply to Ground Lug</i> <i>Line Filter to Ground Lug</i>	1 If removing the aux supply to low voltage power supply to ground lug cable, unplug the cable from the low voltage power assembly. Also unsolder the cable wires from the auxiliary power supply assembly. 2 If removing the line filter to ground lug cable, unplug it from the line filter lug. See Figure 6-4. 3 Using a $\frac{5}{16}$ inch nut driver (Item 9) remove the nut(s) that secure the cable to be removed from the lug and remove it. 4 Reverse these instructions to install the replacement cable.
7 <i>Monitor</i>	1 Find the procedure <i>A02 Display Assembly</i> in Table 6-6. 2 Follow the access instructions found there to access and remove the display assembly. The cable is unplugged from that assembly in the process. 3 Unplug the cable from the monitor. See Figure 6-4 for jack location. 4 Unplug the cable from the auxiliary power supply. See Figure 6-4 for jack location. 5 Reverse these instructions to install the replacement cable.

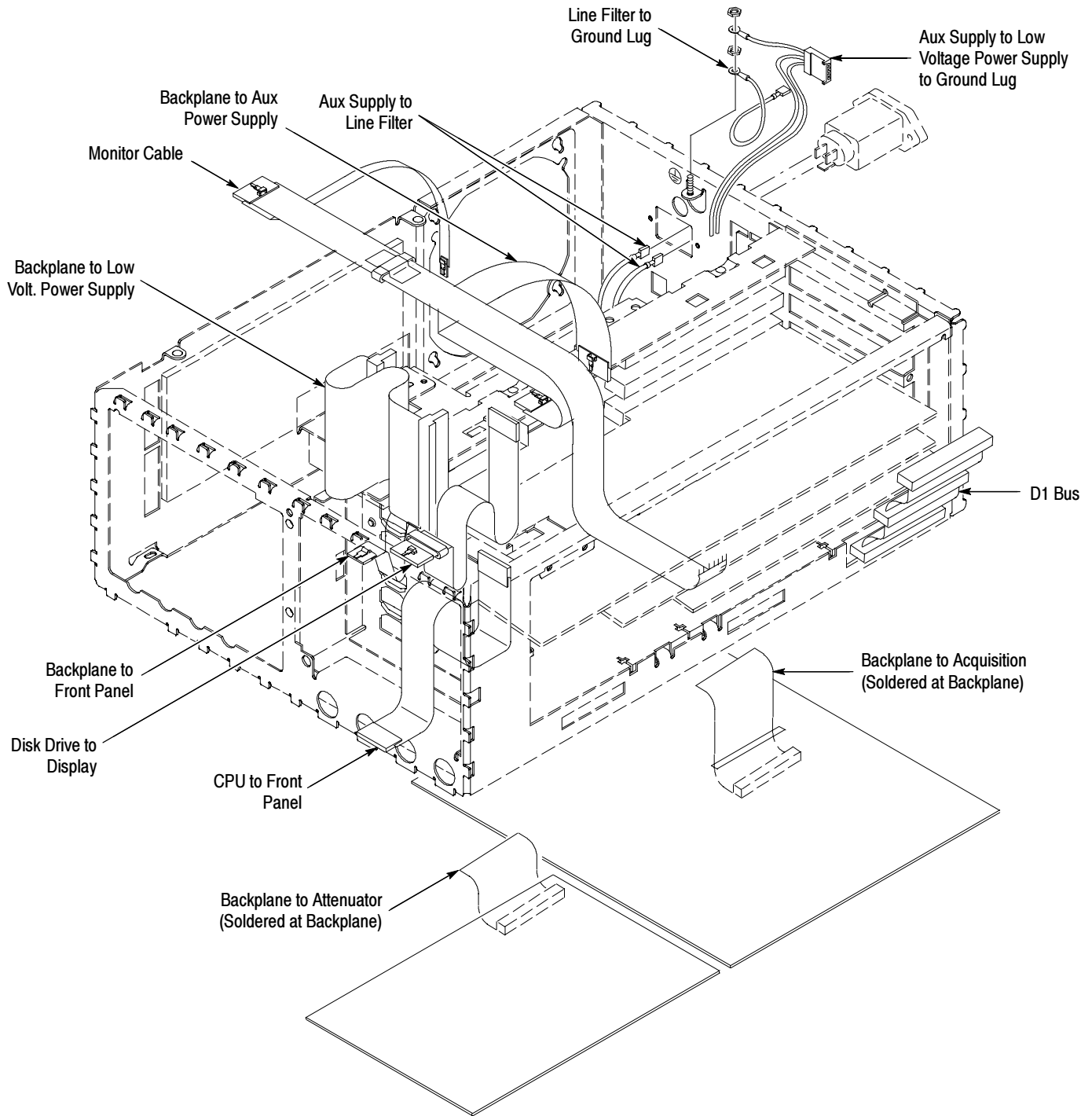

Figure 6-4: Cables and cable routing, B010100 - B079999

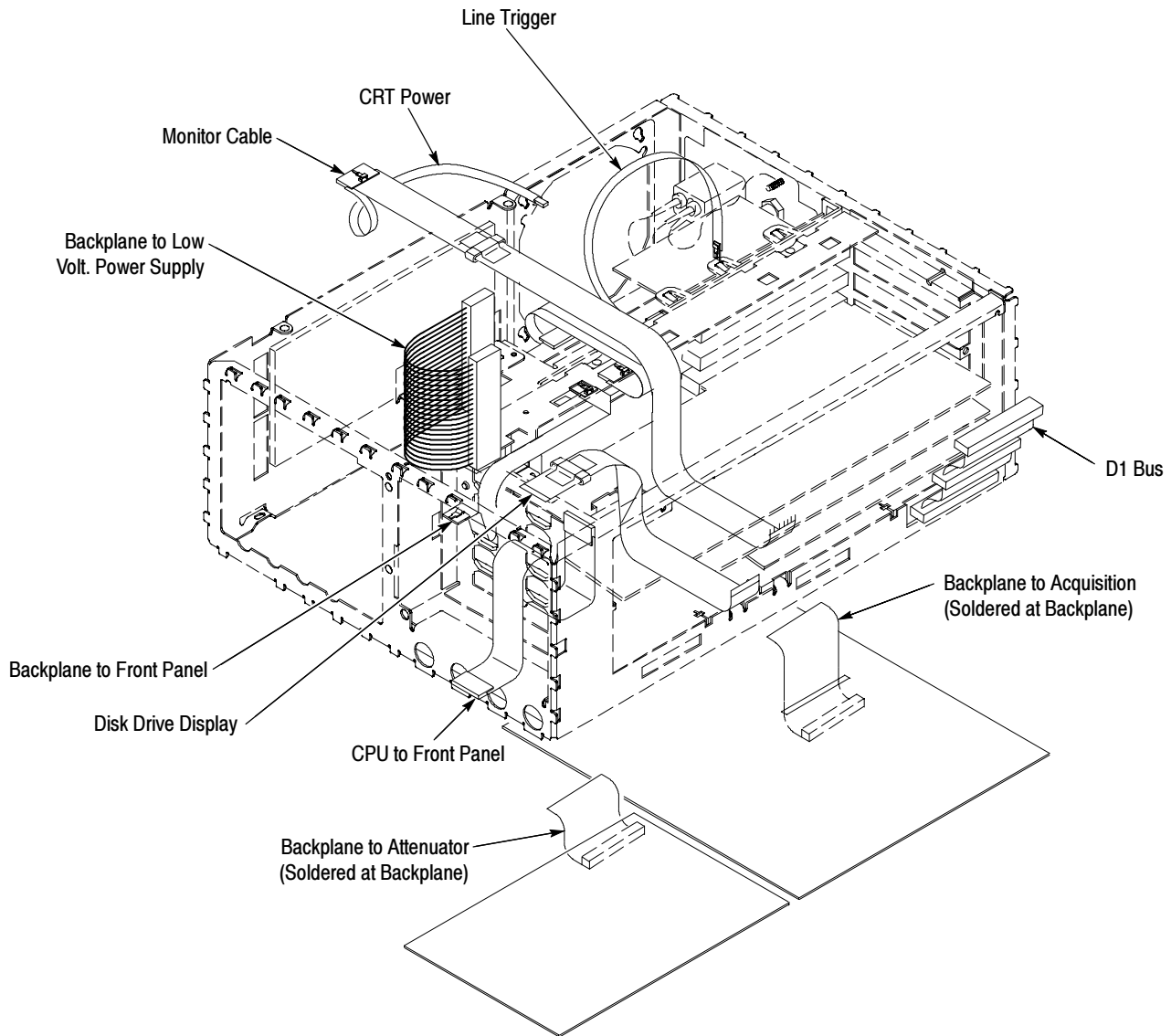

Figure 6-5: Cables and cable routing, B080000 & up

Procedures for Module Removal and Installation

Do the *Access Procedure* (page 6-13) before doing any procedure in this section.

Front-Panel Knobs and Shafts

1. *Assemble equipment and locate modules to be removed:* Have handy a pair of angled-tip tweezers (Item 10). Find the knob(s) to be removed on the front panel.

2. *Orient the oscilloscope:* Set the oscilloscope so its bottom is down on the work surface and its front is facing you.
3. *Remove the knob(s):* Refer to Figure 6-6 while doing the following substeps.
 - a. Grasp any knob you wish to remove and pull it straight out from the front panel slightly to create some clearance between the base of the knob and the front panel.
 - b. Insert the tweezers between the knob and front panel and use them to remove the knob and its shaft.
4. *Disassemble the knob and shaft:* Pull the shaft out of the knob.
5. *Reinstallation:*
 - a. To reinstall, align the inside of the knob to the end of the shaft and push it in until it snaps.
 - b. Insert the shaft of the assembled knob into its hole in the front panel assembly until it stops.
 - c. Rotate the knob while lightly pushing inwards until the shaft slips into its receptacle. Push the knob all the way in to seat the knob assembly.

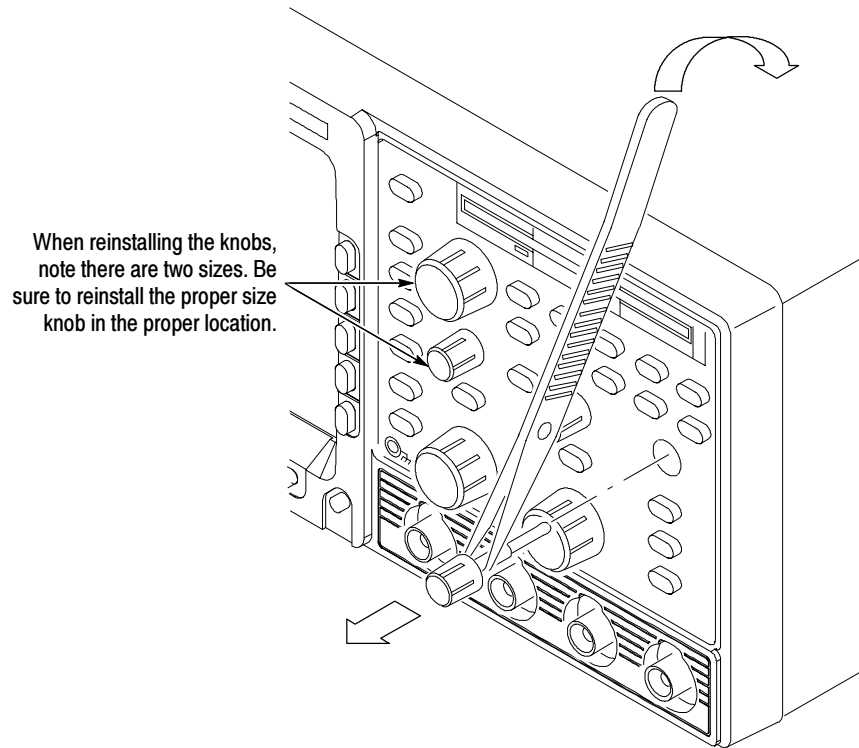

Figure 6-6: Knob and shaft removal

Line Fuse and Line Cord



WARNING. *Unplug the line cord from the line voltage power source before continuing. Failure to do so can cause death or injury.*

1. *Assemble equipment and locate modules to be removed:* Have handy a flat-bladed screwdriver (Item 5). Locate the line fuse and line cord in the locator diagram *Cabinet and Front-Panel Mounted Modules*, Figure 6-2 on page 6-16.
2. *Orient the oscilloscope:* Set the oscilloscope so its bottom is down on the work surface and its rear is facing you. If you are servicing the line cord, do the next step; if you are servicing the line fuse, skip to step 5.
3. *Remove line cord:*
 - a. Find the line cord on the rear cover. (See Figure 6-7.)

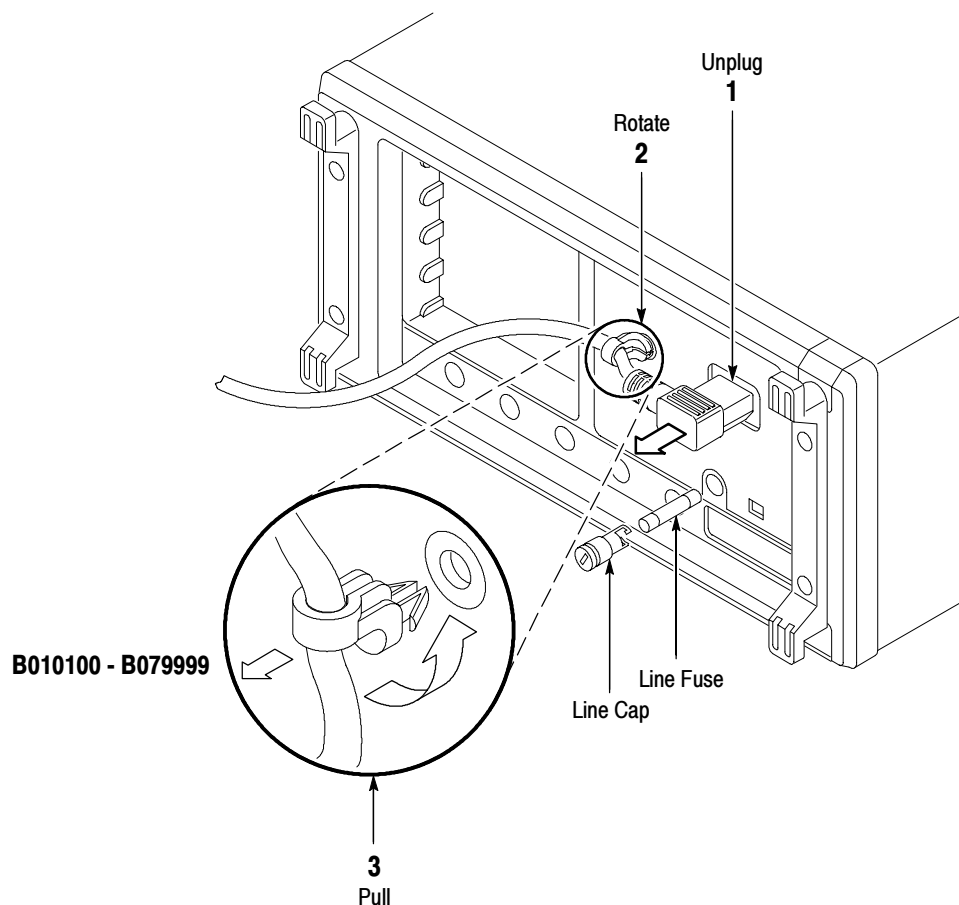

Figure 6-7: Line fuse and line cord removal

- b. Now, remove the line-cord retaining clamp by first unplugging the line cord from its receptacle.
 - c. Next, grasp both the line cord and the retaining clamp and rotate them 90 degrees counter-clockwise.
4. Pull the line cord and clamp away to complete the removal.
 5. *Remove line fuse:* Find the fuse cap on the rear panel. (See Figure 6-7.) Now, remove the fuse cap by turning it counter clockwise using a flat-bladed screwdriver, and remove the line fuse.
 6. *Reinstallation:* Do in reverse steps 3 and 5 to reinstall the line fuse and then the line cord.

**Front Cover, Rear Cover,
Cabinet, Rear EMI Gasket,
and Cabinet Handle and
Feet**

1. *Assemble equipment and locate modules to be removed:*
 - a. Have handy a screwdriver with size T-15 and T-20 Torx® tips (Items 1, 2, and 3). If removing the EMI gasket at the inside rear of the cabinet, also have handy a pair of needle-nose pliers (Item 7).
 - b. Make sure the oscilloscope front cover is installed; if it is not, install it by snapping its edges over the trim ring.
 - c. Locate the rear cover and cabinet in the locator diagram *Cabinet and Front-Panel Mounted Modules*, Figure 6-2 on page 6-16.
2. *Orient the oscilloscope:*
 - a. Pull out on both of the hubs on the cabinet handle to unlock it for positioning. While holding the hubs unlocked, rotate the handle towards the bottom of the oscilloscope.
 - b. Set the oscilloscope so its face is down with its front cover on the work surface and its bottom facing you. Reference Figure 6-8 on page 6-28 as you do the following steps.
3. *Remove the front feet:* If removing a front foot for replacement, use a pair of slip-jaw pliers to firmly grip the foot, then pull with a turning motion to remove. Reverse the process to install the replacement foot. If no other modules are being serviced, skip to the end (step 8) of this procedure.
4. *Remove rear cover:* Remove the four T-15 Torx® screws securing the rear cover to the oscilloscope. Lift off the rear cover. If no other modules are being serviced, skip to the end (step 8) of this procedure.

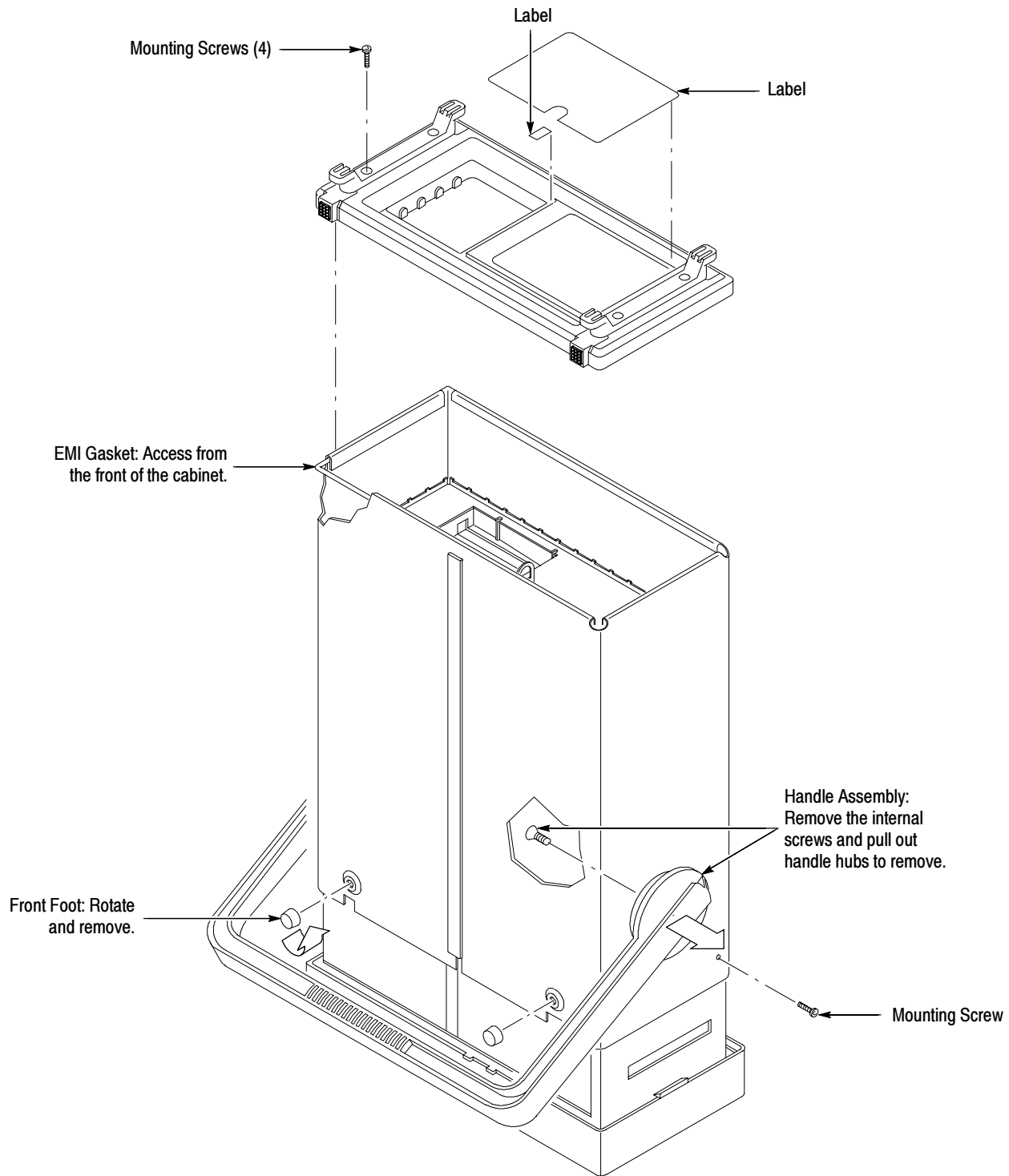

Figure 6-8: Front cover, rear cover, cabinet, emi gasket, and cabinet handle and feet removal

5. *Remove the cabinet:*
 - a. Remove the T-15 Torx® screw at the left side of the oscilloscope.
 - b. Grasp the two handle hubs and pull them outward as if to rotate the handle.
 - c. While holding the handle hubs pulled out, lift the cabinet upwards to slide it off the oscilloscope.
 - d. At the rear of the cabinet, grasp its left and right edges. Take care not to bind or snag the cabinet on the internal cabling as you remove the cabinet.
 - e. If no other cabinet modules are being serviced, skip the rest of this procedure.
6. *Remove the handle assembly:* If removing the handle assembly for cleaning or replacement, do the following substeps:
 - a. Working from the inside of the cabinet, remove the T-20 Torx® screw securing each handle hub to the cabinet.
 - b. Working from the outside of the cabinet, grasp the two handle hubs and pull them outward from the cabinet until they are out of the cabinet.
 - c. While holding the handle hubs pulled out, lift the handle away to remove.

STOP. *DO NOT* do step 7 to remove the EMI gasket from the rear of the cabinet unless it must be replaced due to damage. If you are not replacing that gasket, skip to step 8.

When reinstalling the EMI gasket and the oscilloscope cabinet, carefully follow the instructions given. Unless the instructions are performed properly, the oscilloscope may not meet its emissions requirements (EMI).

7. *Remove the EMI gasket:* If removing the EMI gasket for replacement, do the following substeps.
 - a. Locate the EMI gasket to be removed in the diagram *Front cover, rear cover, cabinet, emi gasket, and cabinet handle and feet removal*, Figure 6-8.
 - b. Look for the point where the ends of the gasket touch in the channel at the rear edge of the cabinet.
 - c. Use a pair of needle-nose pliers to pry up one of the ends of the gasket.
 - d. Grasp the EMI gasket, and gently pull it out of the its channel.

8. Reinstallation of cabinet and rear cover:

- a.** If the EMI gasket was removed, press the EMI gasket back into its groove at the rear edge of the cabinet. When installing, make sure the ends of the gasket touch, but do not overlap. (Cut off excess length if required to prevent overlap.)
- b.** See step 7 to reinstall the handle assembly if it was removed.
- c.** Do, in reverse order, steps 3 and 4 to reinstall the cabinet while observing the following precautions and requirements:
 - Take care not to bind or snag the cabinet on internal cabling; redress cables as necessary.
 - When sliding the cabinet onto the oscilloscope, be sure that the ridge around the rear of the main chassis slides into the groove containing the EMI gasket on the rear of the cabinet.
 - Install the four screws at the rear panel and tighten to 8 inch-lbs torque before installing the single screw at the left side of the cabinet. Tighten this screw to 8 inch-lbs.
- d.** If installing a new rear panel, also do the following:
 - Find the appropriate labels for your rear panel.
 - Remove the covering from the back of the sticky-back labels, align them to the rear panel, and press firmly to install.
- e.** See the procedure *Line Fuse and Line Cord* to reinstall the line cord, which completes the oscilloscope reassembly.

Trim Ring, Menu Elastomer, Menu Buttons, and Front EMI Gaskets

1. *Assemble equipment and locate modules to be removed:*
 - a. Have handy a wooden spudger (Item 11).
 - b. Locate the modules to be removed in the locator diagram *Cabinet and Front-Panel Mounted Modules*, Figure 6-2 on page 6-16.
2. *Orient the oscilloscope:* Set the oscilloscope so its rear is down on the work surface and its bottom is facing you.
3. *Remove the front cover:* If it is installed, grasp the front cover by its left and right edges and snap it off of the front of the oscilloscope. (When reinstalling, align and snap the cover back on.)

STOP. DO NOT touch the carbon contact points on the menu elastomer installed in the trim ring. Also, do not touch the contacts on the menu button flex circuit exposed when you remove the trim ring. You should wear clean cloth gloves that are free of lint when handling the menu elastomer or when touching the menu button flex circuit mounted on the front chassis.

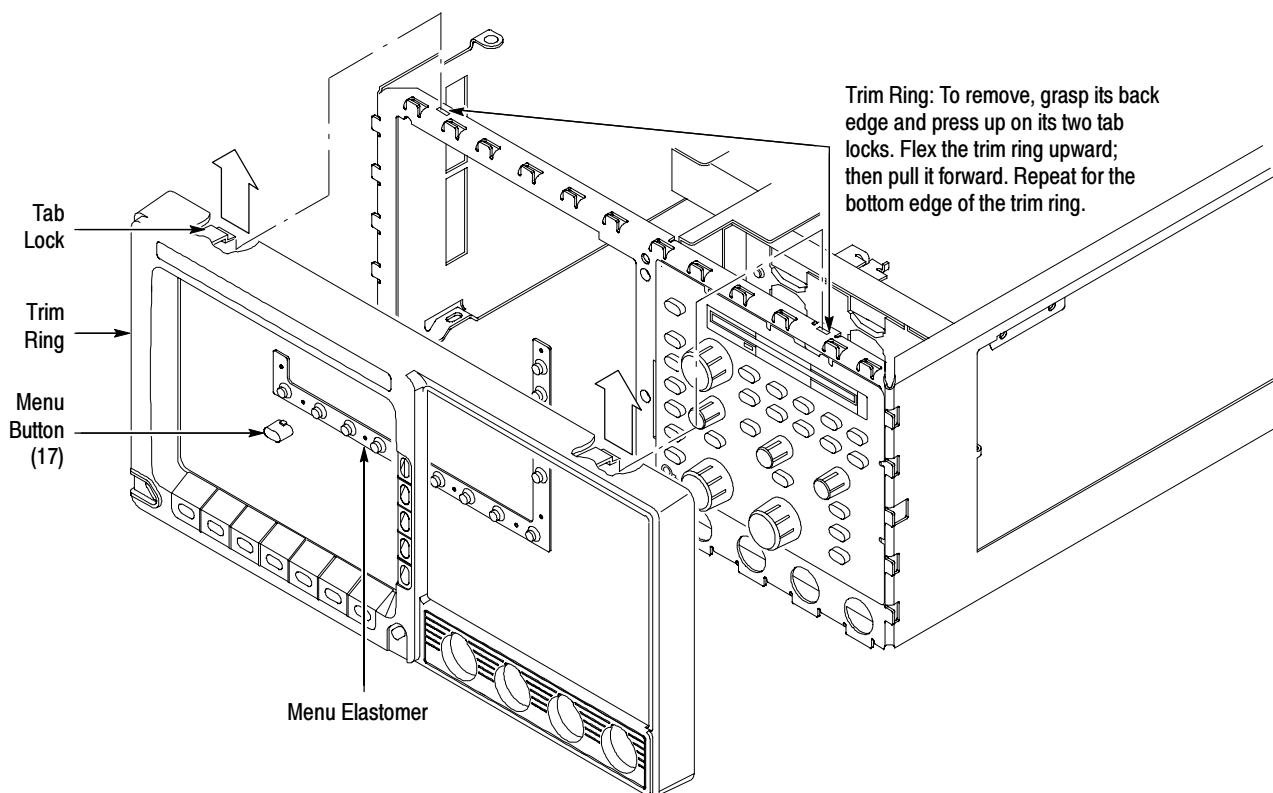

Figure 6-9: Trim ring, menu elastomer, and menu buttons removal

4. *Remove the trim ring:*
 - a. Grasp the trim ring by its top edge and pry it up and lift it forward to snap it off of the top front of the main chassis.
 - b. Repeat the process, prying on the bottom edge of the trim ring to complete its removal.
 - c. Lay the trim ring on its face on the work surface.
5. *Remove the EMI gaskets:* If servicing the front EMI gaskets, lift them out of the trim ring.
6. *Remove the menu elastomer:* If servicing the menu elastomer, lift it out of the trim ring.
7. *Remove the menu buttons:* If servicing the menu buttons, lift them out of the trim ring.
8. *Reinstallation:*
 - a. If the menu buttons were removed, insert each button into its hole in the trim ring.
 - b. If the menu elastomer was removed, align it over the menu button holes in the trim ring and press it in to install. Avoid touching the carbon contact points on the elastomer.
 - c. Without installing the EMI gaskets, align the trim ring to the front of the chassis and push it on to seat. Be sure that both pairs of flex locks, one pair each at the inside top and bottom of the trim ring, snap over the edge of the chassis.
 - d. Do the following subparts to install the EMI gaskets (see Figure 6-10):
 - Install the front cover on the oscilloscope.
 - Lay the scope so its front cover is on the work surface.
 - Align an EMI gasket so it lays between any pair of adjacent flex locks along the groove between the cabinet.
 - Using a wood spudger, push the EMI gasket until it is firmly seated at the bottom of the groove. It should not overlap either flex lock.
 - Repeat the process just described to install the remaining three gaskets.

- e. If the trim ring installed in substep c is a new trim ring, remove the covering from the back of the sticky-back label, align it to the trim ring (see Figure 6-9 on page 6-31), and press firmly to install.
- f. See the following procedures to install those modules removed by the access procedure:
 - *Front Cover, Rear Cover, Cabinet, Rear EMI Gasket, and Cabinet Handle and Feet* (page 6-27) to reinstall the cabinet and rear cover
 - *Line Fuse and Line Cord* (page 6-26) to reinstall the line cord, which completes the oscilloscope reassembly

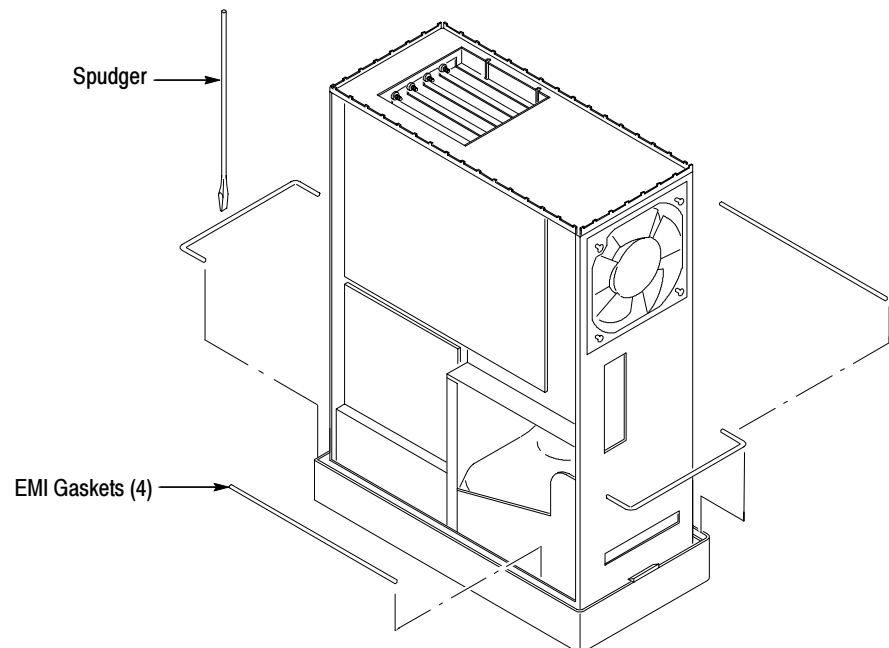

Figure 6-10: EMI gasket removal and installation

Disk drive

For this procedure you will need a screwdriver with a size T-15 Torx tip (items 1 and 2) and a Pozidriv screwdriver (item 6).

1. If you have not already performed the *Access Procedure* on page 6-13 and removed the modules as instructed, do so now.
2. Set the oscilloscope so its bottom is down, and its front is facing you.

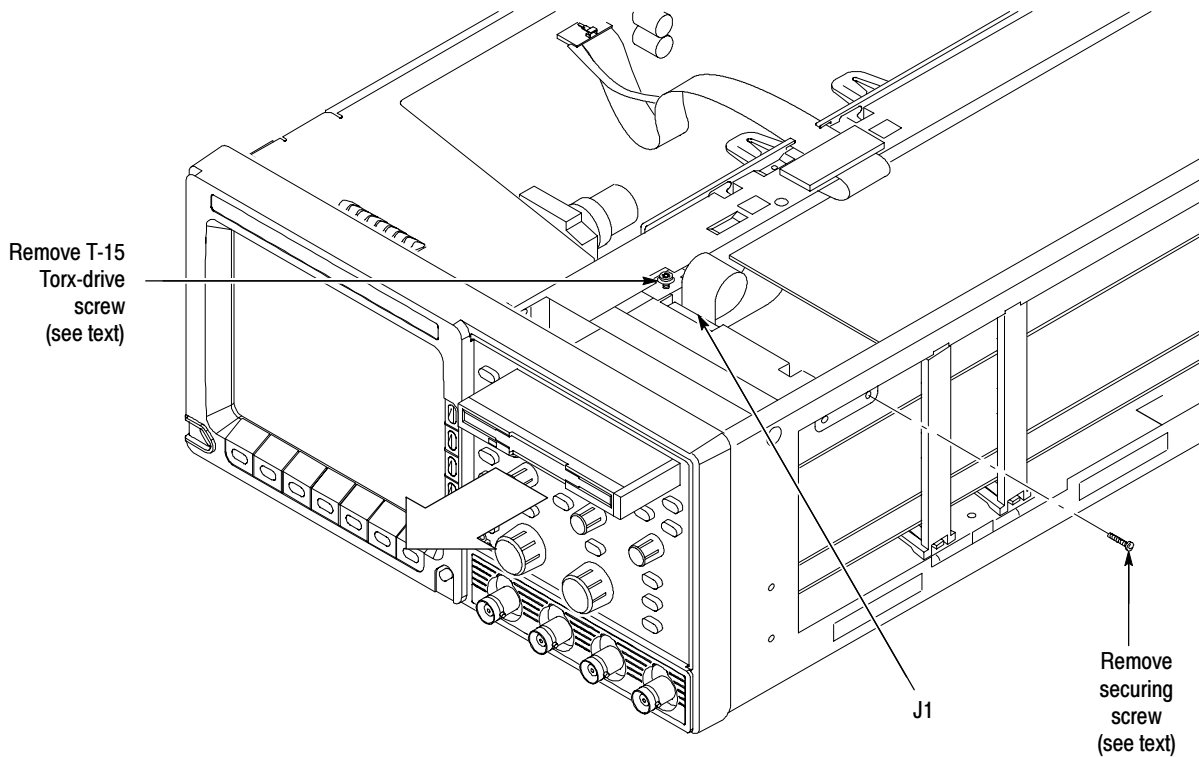

Figure 6-11: Disk drive removal

3. To remove the disk drive, perform the following steps using Figure 6-11 as a guide:
 - a. Lift up on the two locking tabs on J1 of the disk drive.
 - b. Remove the cable from the drive.
 - c. If present, remove the T-15 Torx-drive screw that clamps the drive in the chassis. When replacing the drive, do not reinstall this screw.
 - d. Remove the one or two screws securing the drive to the chassis.
 - e. Grasp the drive by its front edges and pull it out of the front panel to complete its removal.

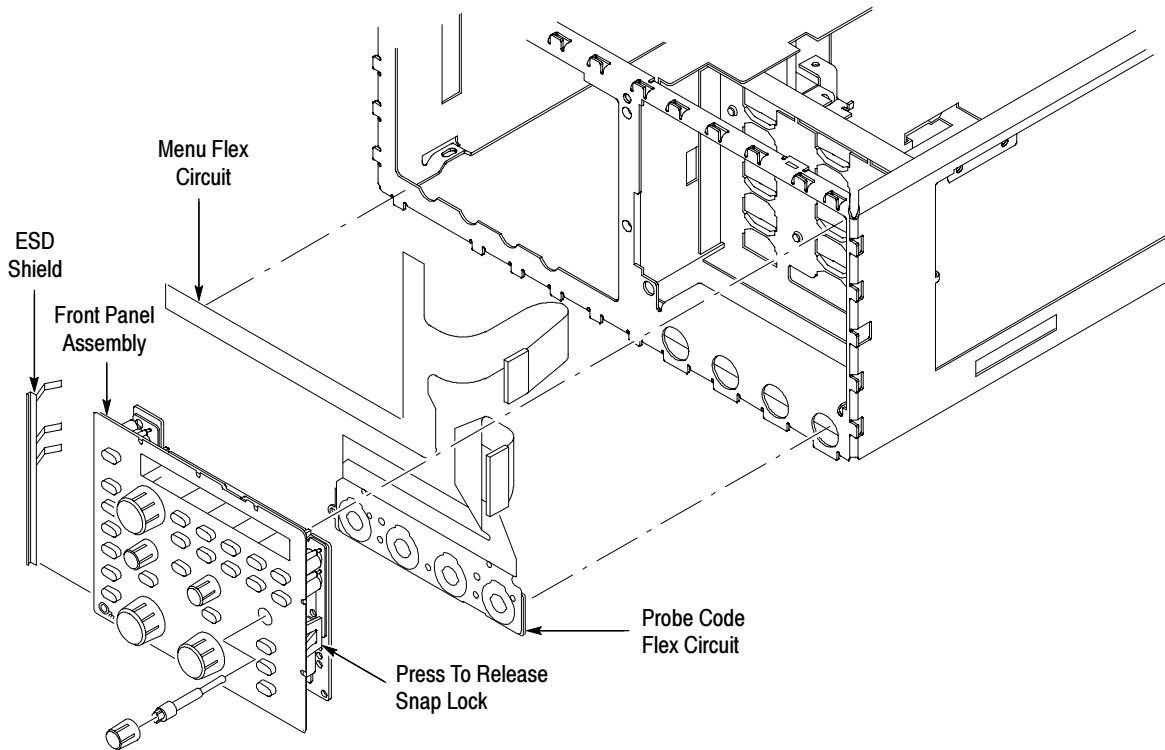

Figure 6-12: A06 Front-Panel assembly, ESD shield, and menu flex and probe code flex circuits removal

6. *Remove the Probe Code Flex Circuit:* If replacing or cleaning the probe code flex circuit, remove the four T-15 Torx® screws, and lift the probe code flex circuit away from the front of the main chassis.

STOP. Perform step 7 only if disassembling for cleaning and lubrication. (Components removed in step 7 are not field replaceable.) Otherwise, skip to step 8 to continue this procedure.

7. *Further disassembly of front-panel assembly:* If the front panel or the front-panel buttons are to be serviced, do the following substeps.
 - a. Remove the front-panel control knobs from the front-panel assembly using the method described in *Front-Panel Knobs and Shafts* on page 6-23.
 - b. Release the five snap locks at the edge and center of the circuit board, and then pull the board away from the assembly until it unplugs from J405. See Figure 6-13.
 - c. Lift the circuit board away from the rest of the assembly.

- d. Hand disassemble the front-panel-assembly components using Figure 6-13 as a guide. Reverse the procedure to reassemble, using the same Figure 6-13 as a guide.

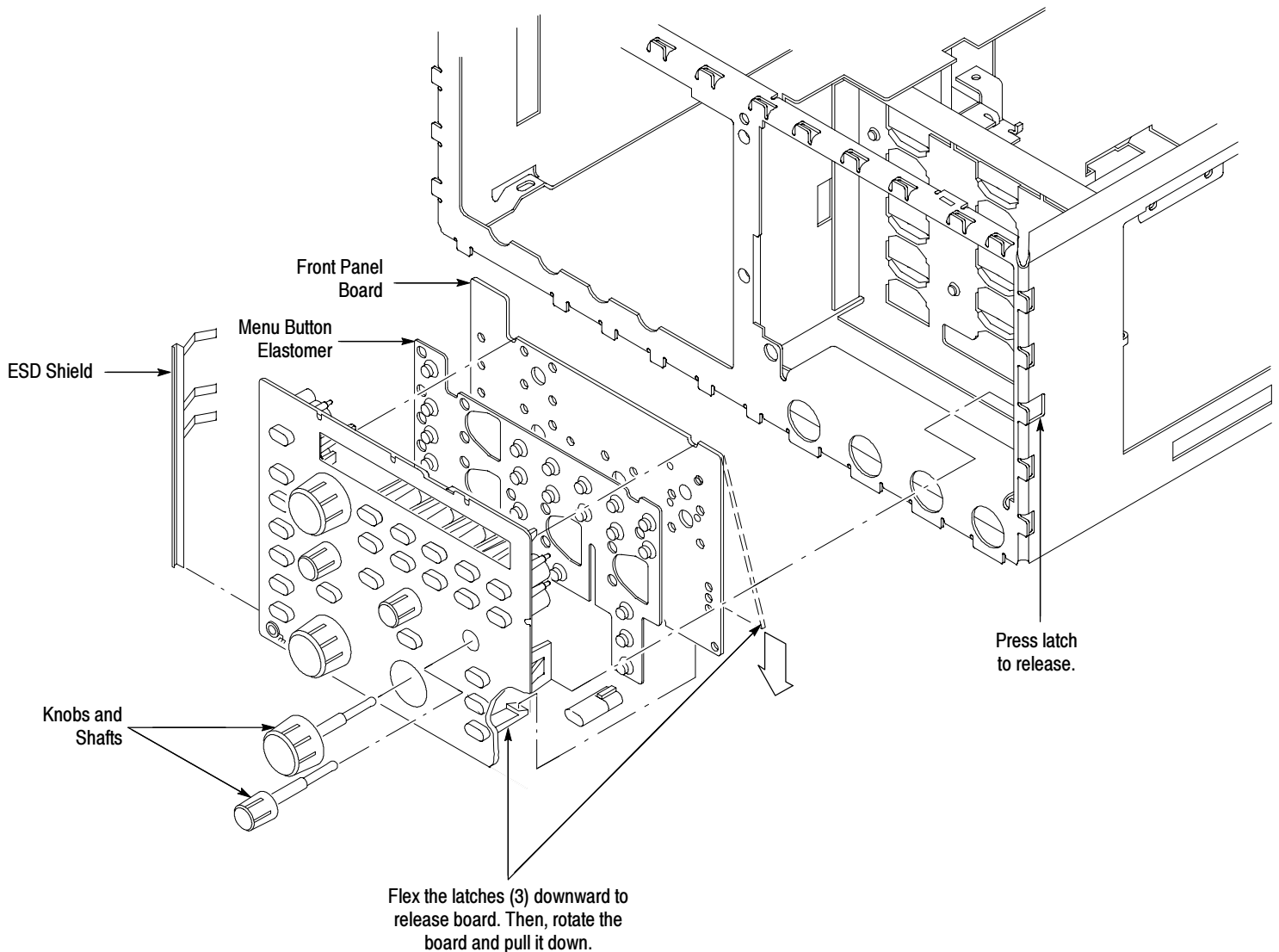

Figure 6-13: Disassembly of the front-panel assembly

STOP. Perform step 8 only if replacing a failed or damaged menu flex circuit with a fresh unit from the factory. (Removal of the circuit is likely to destroy it.) If such is not the case, skip to step 9 to continue this procedure.

- 8.** Remove the menu flex circuit: Pull the flex circuit away from the front of the main chassis. (The flex circuit is held on by its sticky backing.)

9. Reinstallation:

- a.** If the menu flex circuit was removed in step 8, do the following subparts to install a new circuit (reference Figure 6-12 on page 6-36):
 - DO NOT touch the contacts on the menu flex circuit with your bare fingers. You should wear clean cloth gloves that are free of lint when installing the menu flex circuit on the front chassis.
 - Wipe the front of the chassis using isopropyl alcohol and a clean, lint-free cloth. Let the chassis dry. (Some adhesive from the flex circuit you removed will be left on the front of the chassis. This is normal.)
 - Find the score line in the adhesive backing and peel the backing off of the menu flex circuit.
 - Carefully align the three holes on the menu flex circuit to the locator studs on the front of the main chassis. When the alignment is correct, press the flex circuit against the chassis so it adheres to the chassis.
 - Clean the surface of the menu flex circuit just installed using isopropyl alcohol and a clean, lint-free cloth.
- b.** See step 6 to install the probe code flex circuit if it was removed.
- c.** See step 5 to install the ESD shield if it was removed.
- d.** If the front-panel assembly was disassembled for cleaning in step 7, apply a thin coating of bearing grease (Dow Corning #1292) to the two switch patterns (circular patterns for the vertical scale rotary switches) on the circuit board. Then reverse substeps 7a-7d to reassemble, using Figure 6-13 as a guide.
- e.** Do in reverse order substeps 4a through 4d, reversing the procedure outlined in each step. Be sure to dress the CPU-to-front-panel cable so that the loop of extra cable length is in the front-panel cavity of the chassis, as shown in Figure 6-4.
- f.** See the following procedures to install those modules removed by the access procedure:
 - *Front Cover, Rear Cover, Cabinet, Rear EMI Gasket, and Cabinet Handle and Feet* (page 6-27) to reinstall the cabinet and rear cover
 - *Line Fuse and Line Cord* (page 6-26) to reinstall the line cord, which completes the oscilloscope reassembly

**A05 Attenuator Assembly
and Shield**

1. *Access the module:* Be sure you have performed the *Access Procedure* on page 6-13 and removed the modules as instructed.
2. *Assemble equipment and locate modules to be removed:* Have handy a screwdriver with a size T-15 Torx® tip (Items 1 and 2).
3. *Orient the oscilloscope:* Set the oscilloscope so its top is down on the work surface and its front is facing you.
4. *Remove the Attenuator Assembly:*
 - a. Unplug the backplane to attenuator cable at J101.
 - b. Using Figure 6-14 as a guide, remove the four T-15 Torx® screws securing the attenuator assembly to the front of the chassis.
 - c. Lift the attenuator assembly away from the oscilloscope to complete its removal.
5. *Reinstallation:*
 - a. Perform in reverse order substeps 4a and 4c, reversing the removal instructions in each substep to reinstall the assembly.
 - b. See the following procedures in the order listed to replace modules removed by the access procedure:
 - *A06 Front-Panel Assembly, ESD Shield, and Menu Flex and Probe Code Flex Circuits* on page 6-35
 - *Trim Ring, Menu Elastomer, Menu Buttons, and Front EMI Gaskets* on page 6-31
 - *Front Cover, Rear Cover, Cabinet, Rear EMI Gasket, and Cabinet Handle and Feet* (page 6-27) to reinstall the cabinet and rear cover
 - *Line Fuse and Line Cord* (page 6-26) to reinstall the line cord, which completes the oscilloscope reassembly

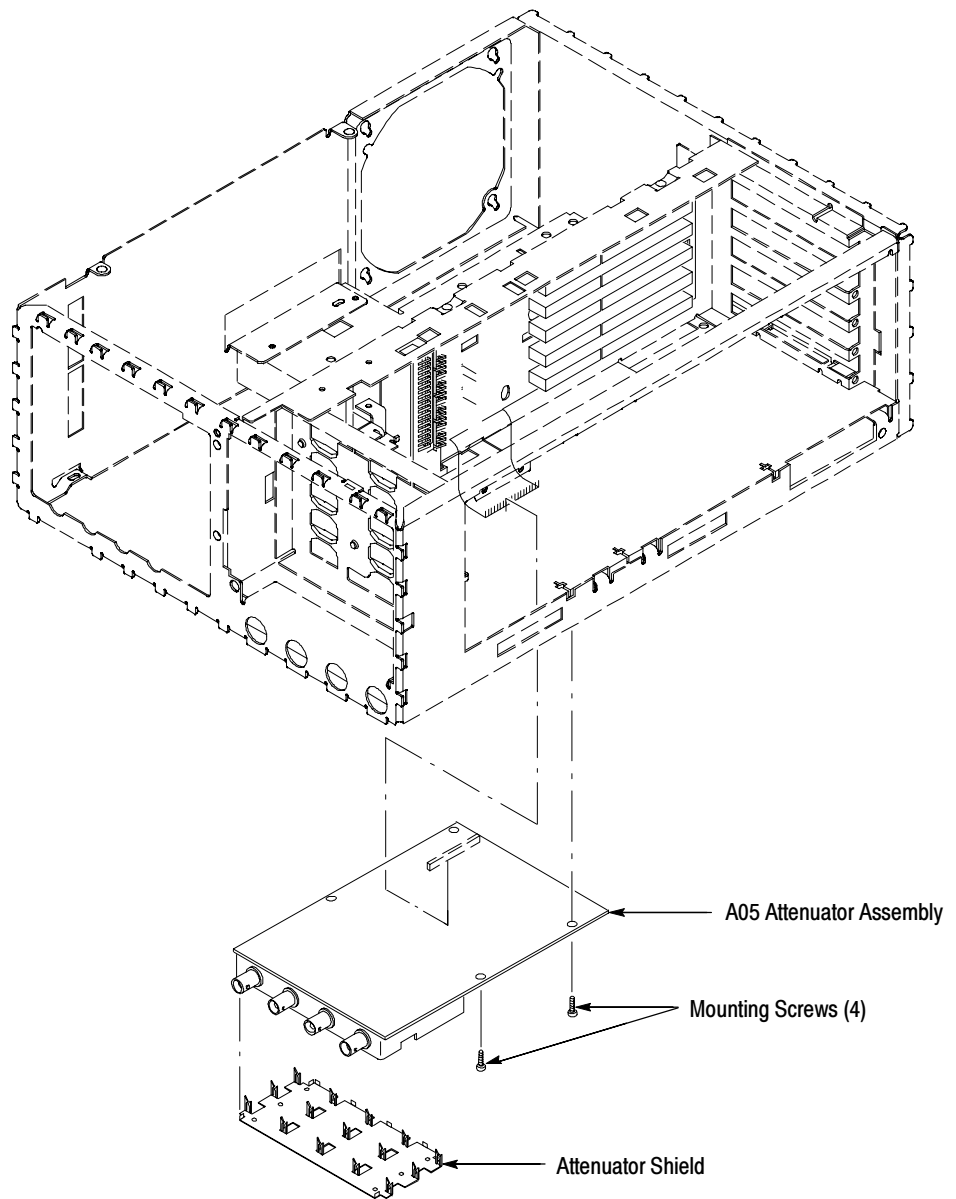

Figure 6-14: A05 Attenuator removal

A26 Monitor assembly

NOTE. *The display tube and the display-driver board are a single module and must be removed and replaced as such. They are listed as a single module in the Replaceable Parts List.*

1. *Access the module:* Be sure you have performed the *Access Procedure* on page 6-13 and removed the modules as instructed.
2. *Assemble equipment and locate modules to be removed:* Have handy a screwdriver with a size T-15 Torx® tip (Items 1 and 2). Locate the module to be removed in the locator diagram *Internal Modules*, Figure 6-3, page 6-19.
3. *Orient the digitizing oscilloscope:* Set the digitizing oscilloscope so its bottom is down on the work surface, with its front facing you.



WARNING. Monitor assembly handling: *Use care when handling a monitor. If you break its display tube it may implode, scattering glass fragments with high velocity and possibly injuring you. Wear protective clothing, including safety glasses (preferably a full-face shield). Avoid striking the display tube with or against any object.*

Monitor storage: *Store the monitor with its display tube face down in a protected location, placing it on a soft, nonabrasive surface to prevent scratching the face plate.*

4. *Remove the monitor:*
 - a. Take the precautions outlined in the *WARNING* above. Refer to Figure 6-15 while doing the following substeps.
 - b. Unplug the main cable at (J901), then rotate the digitizing oscilloscope so its top is down on the work surface, with its bottom facing upwards.
 - c. Remove the three T-15 Torx® screws securing the monitor assembly to the bottom of the main chassis. Return the digitizing oscilloscope to the orientation established in step 2.



WARNING. *High-voltage is present on the anode lead. It is NOT necessary to unplug the anode from the monitor when removing or replacing the monitor module; therefore, do not do so.*

- d. Remove the three T-15 Torx® screws securing the monitor assembly to the top of the chassis. (See Figure 6-15 to locate the screws.)

- e. Push up on the left top tab lock on the trim ring and pull the left corner of the trim ring forward slightly. (The left top tab lock is shown in Figure 6-9 on page 6-31.)
- f. Tilt the rear of the monitor assembly upward slightly. Slide the monitor assembly back in the main chassis until it stops (about $\frac{3}{4}$ inch). Now lift it straight up out of the the top of the main chassis to complete the removal.
- g. While heeding the **WARNING** on monitor handling that immediately precedes step 4 of this monitor removal procedure, store the monitor assembly in a protected location. Place it face down on a soft, nonabrasive surface to prevent scratching the face plate.

5. *Reinstallation:*

- a. Perform in reverse order 4a-4f, reversing the removal instructions in each step and substep to reinstall the assembly. If the EMI clips on the monitor are replaced, be sure to center them in the notched area of the top and bottom of the chassis.
- b. See the following procedures in the order listed to replace modules removed by the access procedure:
 - *A06 Front-Panel Assembly, ESD Shield, and Menu Flex and Probe Code Flex Circuits* on page 6-35
 - *Trim Ring, Menu Elastomer, Menu Buttons, and Front EMI Gaskets* on page 6-31
 - *Front Cover, Rear Cover, Cabinet, Rear EMI Gasket, and Cabinet Handle and Feet* (page 6-27) to reinstall the cabinet and rear cover
 - *Line Fuse and Line Cord* (page 6-26) to reinstall the line cord, which completes the oscilloscope reassembly

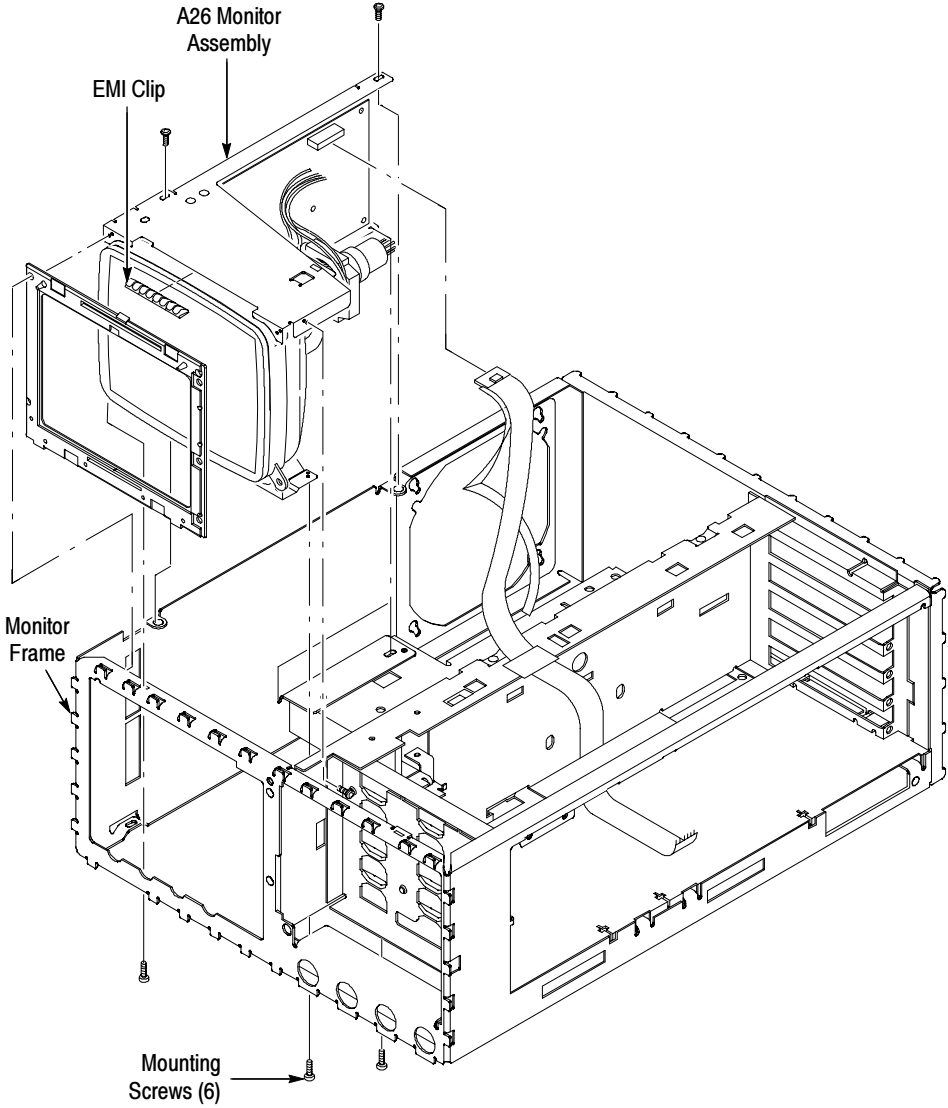

Figure 6-15: A26 Monitor assembly removal

**A08 Jumper Board
Assembly, D1 Bus, and
Board Supports**

1. *Locate the modules to be removed:* Find the modules to be removed in the locator diagram *Internal Modules*, (Figure 6-3 on page 6-19) or in Figure 6-4 on page 6-22.
2. *Orient the digitizing oscilloscope:* Set the digitizing oscilloscope so its left side is down, with its front facing to the left of you.
3. *Remove the board supports:* Depress the snap lock at the bottom end of the board support and tilt the support outwards to remove from the chassis. Repeat for the second and third board supports. See Figure 6-16.
4. *Remove the D1 Bus:* Grasp the D1 bus by its cable pull tab and pull to unplug it from J1 of the Display assembly. Then grasp the cable and pull to unplug it from J3 of the acquisition assembly and J2 of the DSP assembly. See Figure 6-16.
5. *Remove the jumper board assembly:* Grasp the jumper board assembly by opposite edges and pull out to unplug it from J102 of the attenuator assembly and J9 of the acquisition assembly. Take care to pull the jumper board straight out with a minimum of rocking motion. See Figure 6-16.

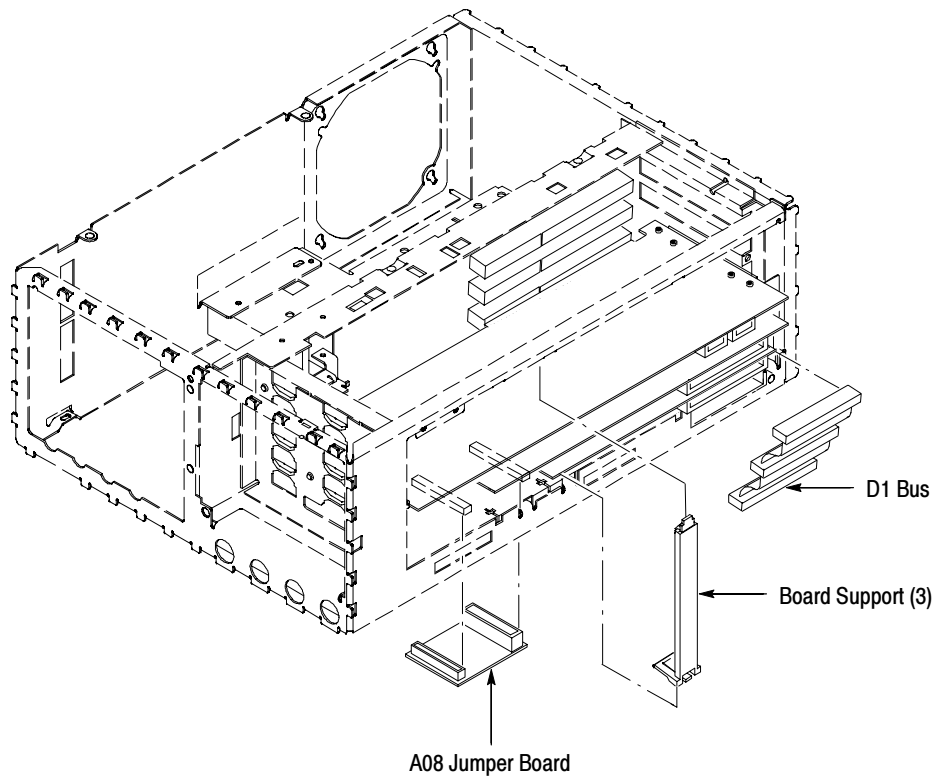

Figure 6-16: A08 Jumper board assembly, D1 Bus, and board supports removal

6. *Reinstallation:* Do steps 3 through 5, reversing instructions in each step to reinstall any module removed.

A03 CPU Assembly

1. *Access the module:* Be sure you have performed the *Access Procedure* on page 6-13 and removed the modules as instructed.
2. *Assemble equipment and locate modules to be removed:* Have handy a screwdriver with a size T-15 Torx® tip (Items 1 and 2). Locate the modules to be removed in the locator diagram *Internal Modules*, Figure 6-3, page 6-19.
3. *Orient the digitizing oscilloscope:* Set the digitizing oscilloscope so its left side is down, with its front facing to the left of you.
4. *Remove the CPU board:* Using Figure 6-17 as a guide, perform the following substeps:
 - a. Unplug the CPU to front panel cable from the CPU assembly at J101.
 - b. Lift up on the two locking tabs on J500 of the CPU assembly.
 - c. Remove the cable from the drive.
 - d. Remove the single T-15 Torx® screw from the bracket covering the *unused rear-panel slot* at the inside rear corner of the main chassis or the two screws from the bracket that secures the option assembly at the inside rear corner of the main chassis.
 - e. Remove the single T-15 Torx® screw from the bracket that secures the CPU assembly at the inside rear corner of the main chassis.
 - f. Working from the rear of the oscilloscope, remove the single T-15 Torx® screw from the bracket that secures the CPU assembly to the rear of the main chassis.
 - g. Grasp the board by its edge and pull outward to unplug it from J3 of the backplane assembly.
 - h. Slide the board part way out until you can reach the battery cable at J5. Unplug the battery cable.
 - i. Slide the board the rest of the way out of the main chassis to complete its removal.

5. *Reinstallation:*

- a. Perform in reverse order substeps 4a-4i, reversing the removal instructions in each step and substep to reinstall the assembly. After plugging in the CPU to front panel cable at J101, be sure to dress the cable so that the loop of extra cable is tucked behind the front-panel assembly, as shown in Figure 6-17. The cable should come from J101 on the CPU assembly and route directly through the chassis opening to the front-panel cavity.
- b. See the following procedures in the order listed to replace modules removed by the access procedure:
 - *A08 Jumper Board Assembly, D1 Bus, and Board Supports* on page 6-44 (board supports)
 - *Front Cover, Rear Cover, Cabinet, Rear EMI Gasket, and Cabinet Handle and Feet* (page 6-27) to reinstall the cabinet and rear cover
 - *Line Fuse and Line Cord* (page 6-26) to reinstall the line cord, which completes the oscilloscope reassembly

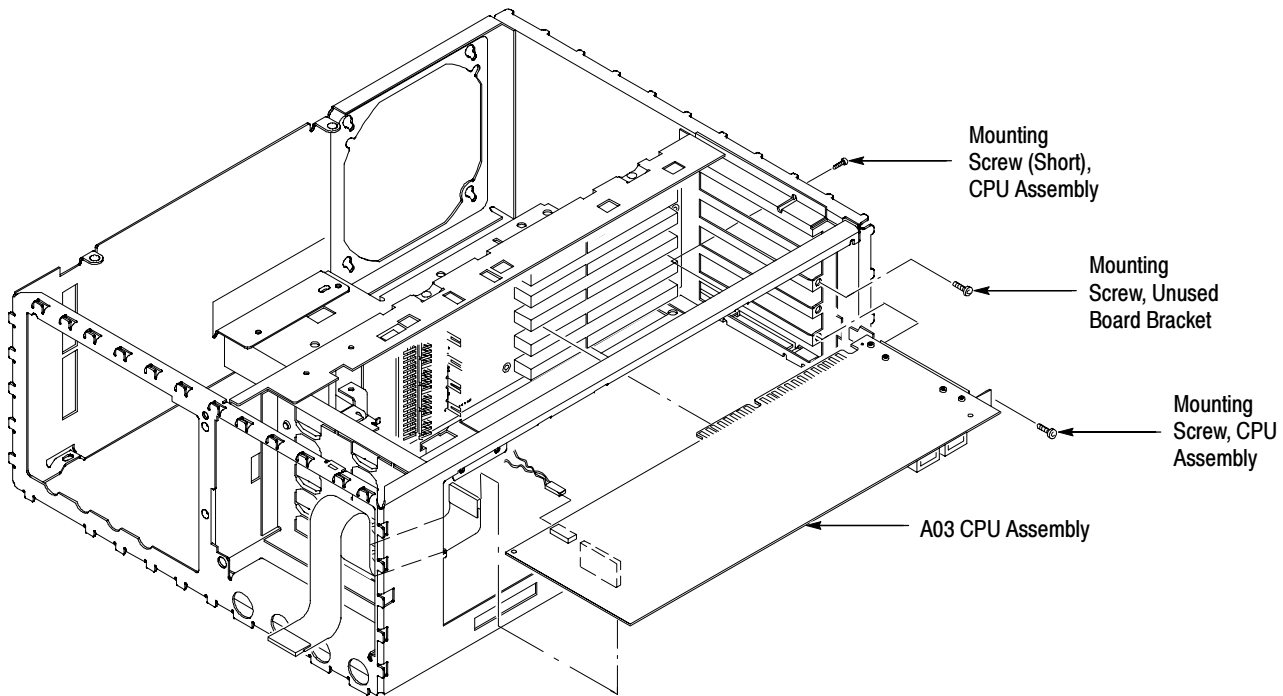

Figure 6-17: A03 CPU removal

A02 Display Assembly

1. *Access the module:* Be sure you have performed the *Access Procedure* on page 6-13 and removed the modules as instructed.
2. *Assemble equipment and locate modules to be removed:* Have handy a screwdriver with a size T-15 Torx® tip (Items 1 and 2). Locate the modules to be removed in the locator diagram *Internal Modules*, Figure 6-3 on page 6-19.
3. *Orient the digitizing oscilloscope:* Set the digitizing oscilloscope so its left side is down, with its front facing to the left of you.
4. *Remove the display board:* Using Figure 6-18 as a guide, perform the following substeps:
 - a. Unplug the monitor to display cable at J2.
 - b. Remove the single T-15 Torx® screw from the bracket that secures the CPU assembly at the inside rear corner of the main chassis.
 - c. Remove the single T-15 Torx® screw from the bracket that secures the display assembly at the inside rear corner of the main chassis.
 - d. Working from the rear of the oscilloscope, remove the single T-15 Torx® screw from the bracket that secures the display assembly to the rear of the main chassis.
 - e. Grasp the board by its edge and pull outward to unplug it from J4 of the backplane assembly to complete the removal.
5. *Reinstallation:*
 - a. Perform in reverse order substeps 4a-4e, reversing the removal instructions in each substep to reinstall the assembly.
 - b. See the following procedures in the order listed to replace modules removed by the access procedure:
 - *A08 Jumper Board Assembly, D1 Bus, and Board Supports* on page 6-44 (board supports and D1 bus only)
 - *Front Cover, Rear Cover, Cabinet, Rear EMI Gasket, and Cabinet Handle and Feet* (page 6-27) to reinstall the cabinet and rear cover
 - *Line Fuse and Line Cord* (page 6-26) to reinstall the line cord, which completes the oscilloscope reassembly

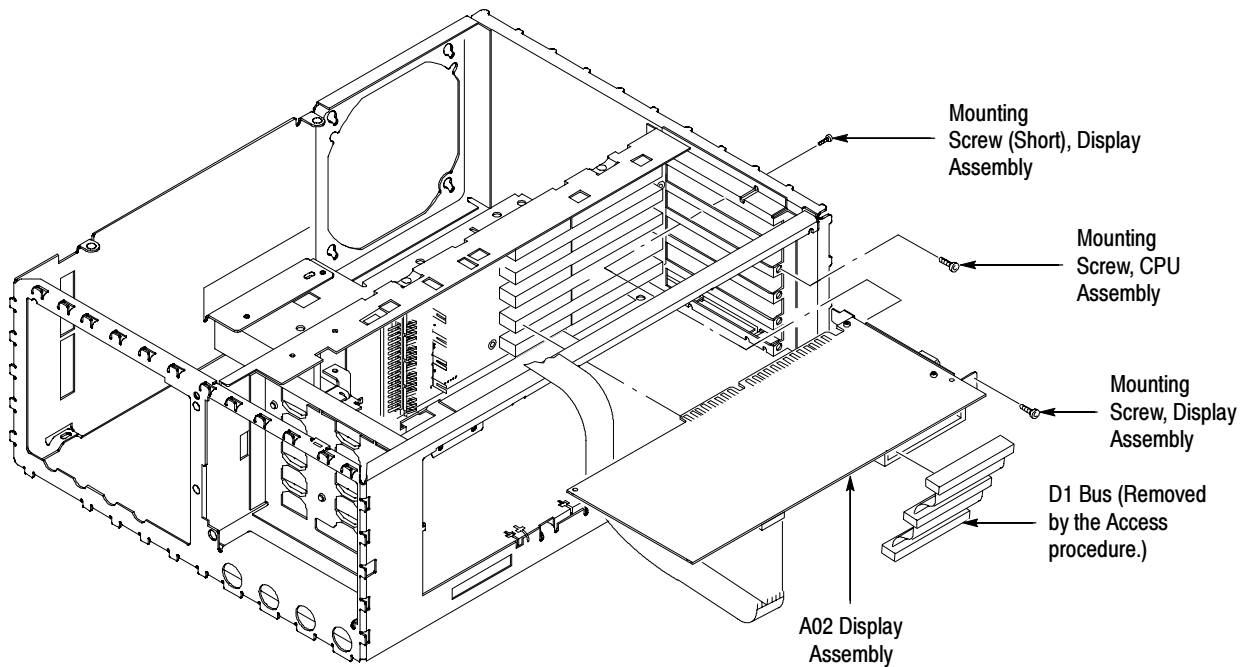

Figure 6-18: A02 Display assembly removal

A09 DSP Assembly

1. *Access the module:* Be sure you have performed the *Access Procedure* on page 6-13 and removed the modules as instructed.
2. *Assemble equipment and locate modules to be removed:*
 - a. Have handy a screwdriver with a size T-15 Torx® tip (Items 1 and 2).
 - b. Locate the modules to be removed in the locator diagram *Internal Modules*, Figure 6-3 on page 6-19.
3. *Orient the digitizing oscilloscope:* Set the digitizing oscilloscope so its left side is down, with its front facing to the left of you.
4. *Remove the DSP Assembly:* Use Figure 6-19 as a guide perform the following substeps:
 - a. Unplug the battery-backup cable at J5.
 - b. Remove the single T-15 Torx® screw from the bracket that secures the display assembly at the inside rear corner of the main chassis.
 - c. Remove the single T-15 Torx® screw from the bracket that secures the DSP assembly at the inside rear corner of the main chassis.

- d. Working from the rear of the oscilloscope, remove the single T-15 Torx® screw from the bracket that secures the DSP assembly to the rear of the main chassis.

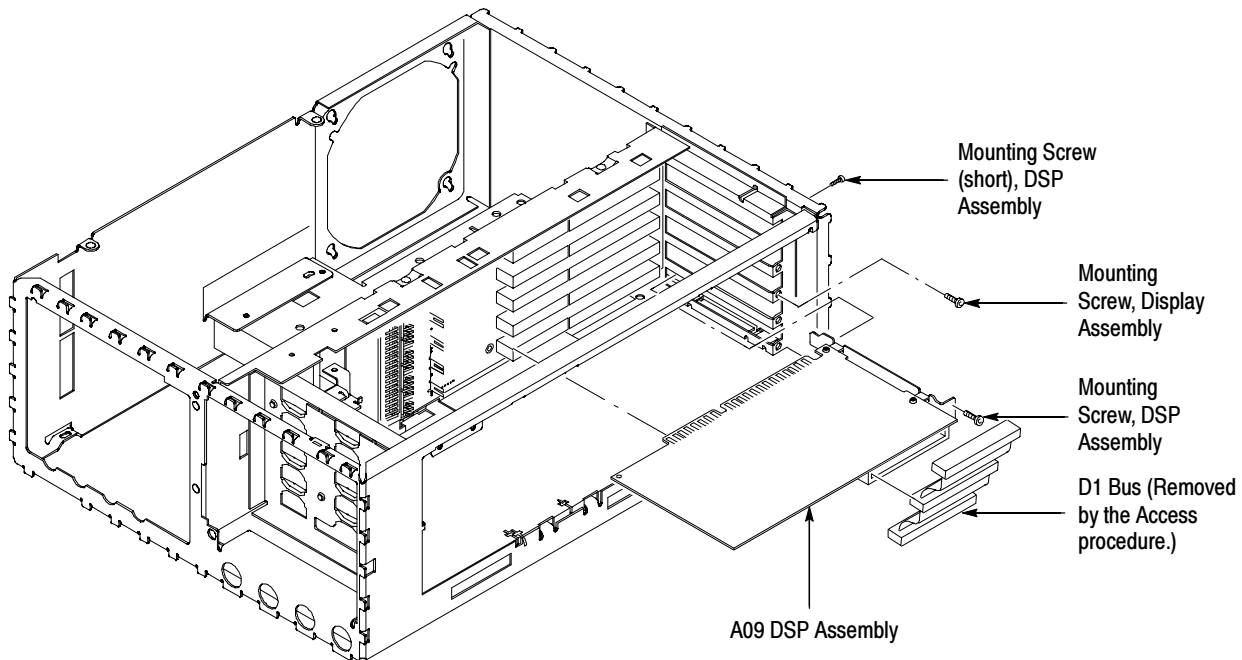

Figure 6-19: A09 DSP assembly removal

- e. Grasp the board by its edge and pull outward to unplug it from J5 of the backplane assembly to complete the removal.
5. *Reinstallation:*
 - a. Perform in reverse order substeps 4a-4e, reversing the removal instructions in each substep to reinstall the assembly.
 - b. See the following procedures in the order listed to replace modules removed by the access procedure:
 - *A08 Jumper Board Assembly, D1 Bus, and Board Supports* on page 6-44 (board supports and D1 bus only)
 - *Front Cover, Rear Cover, Cabinet, Rear EMI Gasket, and Cabinet Handle and Feet* (page 6-27) to reinstall the cabinet and rear cover
 - *Line Fuse and Line Cord* (page 6-26) to reinstall the line cord, which completes the oscilloscope reassembly

A01 Backplane Assembly and its Mount

1. *Access the module:* Be sure you have performed the *Access Procedure* on page 6-13 and removed the modules as instructed.
2. *Assemble equipment and locate modules to be removed:*
 - a. Have handy a screwdriver with a size T-15 Torx® tip (Items 1 and 2) and a flat-bladed screwdriver (Item 5).
 - b. Locate the modules to be removed in the locator diagram *Internal Modules*, Figure 6-3 on page 6-19.
3. *Orient the digitizing oscilloscope:* Set the digitizing oscilloscope so its left side is down, with its front facing to the left.
4. *Remove the backplane assembly:* Using Figure 6-20 as a guide, perform the following substeps:
 - a. There may be board brackets, mounted on the rear panel, that correspond to unused board slots or options in the *backplane assembly*. For any bracket, do the following subparts to remove it:
 - Remove the T-15 Torx® screw(s) that secure(s) the bracket at the inside rear corner of the main chassis.
 - Working from the rear of the oscilloscope, remove the T-15 Torx® screw(s) from the bracket(s) that secure(s) the bracket or assembly to the rear of the main chassis.
 - b. Unplug the backplane to acquisition cable at J7 of the acquisition assembly.
 - c. Unplug the backplane to attenuator cable at J101 of the attenuator assembly.
 - d. Unplug the backplane to AUX power cable at J6 of the backplane.
 - e. Unplug the backplane to front panel cable at J8 of the backplane assembly.
 - f. Unplug the backplane to low voltage power cable at J7 of the backplane assembly.

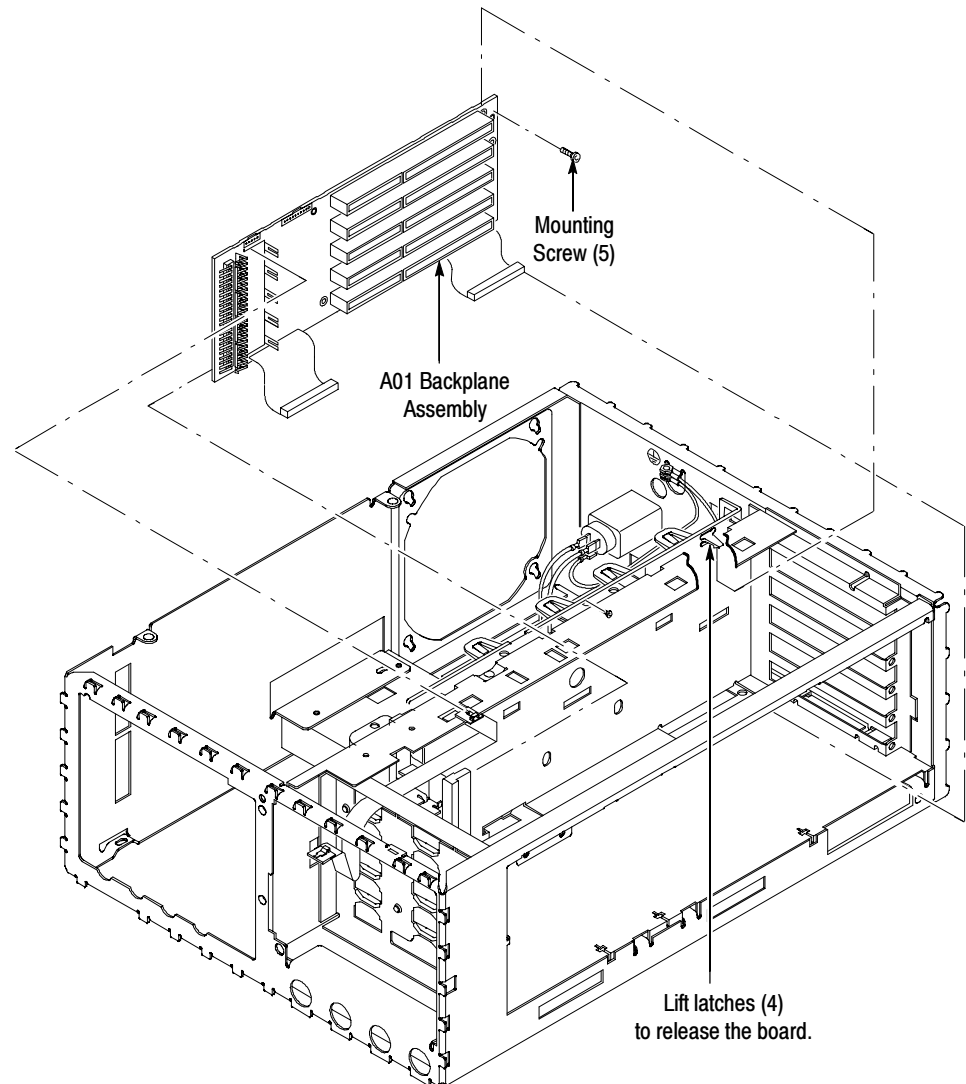

Figure 6-20: A01 Backplane assembly and its mount removal

- g.** Remove the five T15 Torx® screws mounting the board to the chassis.
- h.** Turn the digitizing oscilloscope so its bottom is facing down on the work surface. Leave its front facing to the left.
- i.** Find the flex lock nearest the front of the digitizing oscilloscope. Using a flat-bladed screwdriver, push the flex lock so it flexes enough to clear the board.
- j.** While holding the flex lock, slightly pull up on the front corner of the board nearest that retainer until the board clears that flex lock. Repeat for the remaining three flex locks.

- k.** Once the board is clear of all four flex locks, grasp the board by the edge near those flex locks and rotate that edge upwards slightly and pull the board out of its retainer slot at its opposite edge.
- l.** As you lift the backplane assembly out of the chassis, guide the backplane to attenuator and backplane to acquisition cables up through their slots in the bottom of the chassis.
- m.** Lift the assembly all of the way out of the chassis to complete the removal.

5. Reinstallation:

- a.** Perform in reverse order substeps 4a-4m reversing the removal instructions in each substep to reinstall the assembly. Observe the following precautions as you do the substeps:
 - Be sure to guide the backplane to attenuator and backplane to acquisition cables up through their slots in the bottom of the chassis when doing step 4l.
 - Be sure to align the board to the retainer slot when doing step 4k.
 - Seat the board until the four retainers snap over the edge of the backplane assembly when doing substep 4j.
- b.** See the following procedures in the order listed to replace modules removed by the access procedure:
 - *A08 Jumper Board Assembly, D1 Bus, and Board Supports* on page 6-44 (board supports and D1 bus only).
 - *Front Cover, Rear Cover, Cabinet, Rear EMI Gasket, and Cabinet Handle and Feet* (page 6-27) to reinstall the cabinet and rear cover.
 - *Line Fuse and Line Cord* (page 6-26) to reinstall the line cord, which completes the oscilloscope reassembly.

Back-Up Batteries



CAUTION. *The batteries used in this oscilloscope can present a fire or chemical burn hazard if mistreated. Do not recharge, rapidly discharge, disassemble, heat above 100° C, or incinerate.*

Replace batteries with the part number listed in the Replaceable Parts List only. Use of another battery presents a risk of fire or explosion.

Dispose of used batteries promptly. Small quantities of used batteries may be disposed of in normal refuse. Keep away from children. Do not disassemble, and do not dispose of in fire.

STOP. *Disconnection of the batteries from their plugs results in the loss of all saved front panel setups and saved waveforms. Adjustment constants, stored internally when the oscilloscope is adjusted, are not lost.*

- 1.** *Assemble equipment and locate modules to be removed:* Locate the back-up battery to be removed in the locator diagram *Internal Modules*, Figure 6-3, page 6-19.
- 2.** *Orient the digitizing oscilloscope:* Set the digitizing oscilloscope so its top is down on the work surface, with its right side facing you.
- 3.** *Remove back-up battery 1:* Unplug the back-up battery cable at J5 of the CPU assembly. Then pull the battery out of its clamp near the front of the chassis to remove.
- 4.** *Remove back-up battery 2:* Unplug the back-up battery cable at J5 of the DSP assembly. Then pull the battery out of its clamp near the front of the chassis to remove.
- 5.** *Remove the battery retaining clip:* If replacement of the battery clip is necessary, remove the T15 Torx® screw mounting the clip to the chassis.

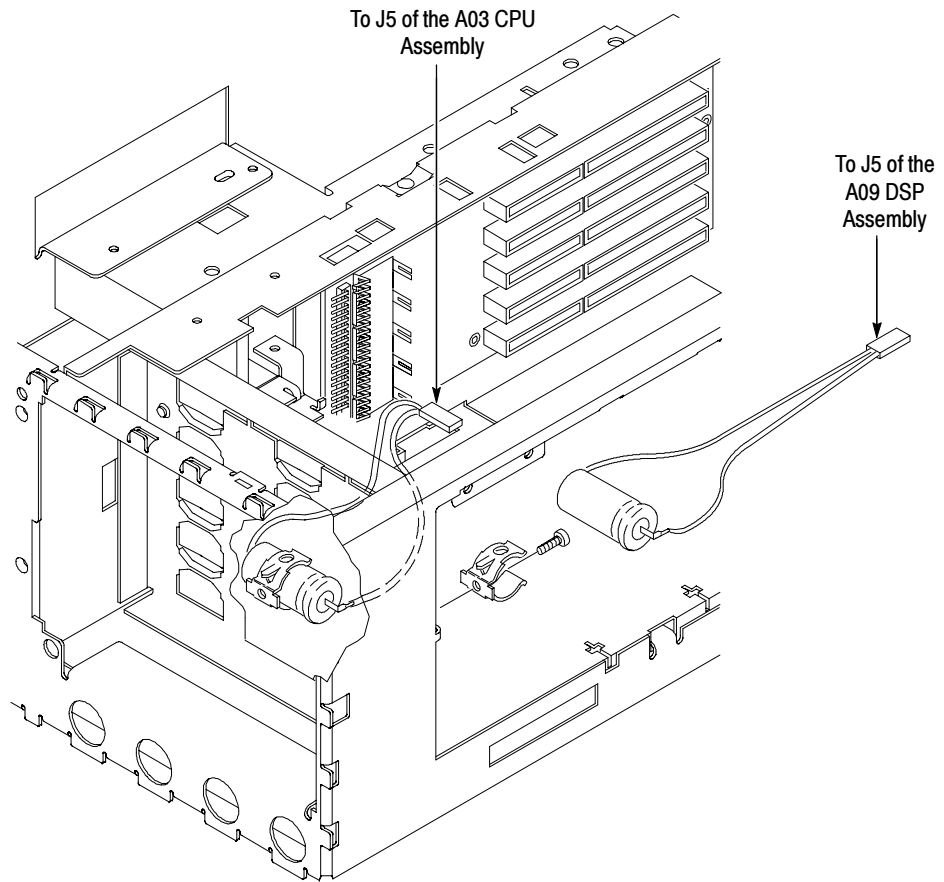

Figure 6-21: Battery removal

6. Reinstallation:

- a. If the battery retaining clip(s) was removed, do step 5, reversing the removal instructions to reinstall the each battery clip.
- b. Do steps 3 and 4, reversing the removal instructions to reinstall the each battery.
- c. See the following procedures in the order listed to replace modules removed by the access procedure:
 - *Front Cover, Rear Cover, Cabinet, Rear EMI Gasket, and Cabinet Handle and Feet* (page 6-27) to reinstall the cabinet and rear cover
 - *Line Fuse and Line Cord* (page 6-26) to reinstall the line cord, which completes the oscilloscope reassembly

**Power Factor Correction
Module
B080000 & up**

1. *Access the module:* Be sure you have performed the *Access Procedure* on page 6-13 and removed the modules as instructed.
2. *Locate modules to be removed:*
 - a. Use a screwdriver with a size T-15 Torx® tip (Items 1 and 2) and a 1/4 inch nut driver.
 - b. Locate the Power Factor Correction module in the locator diagram *Internal Modules*, Figure 6-3 on page 6-19.
3. *Orient the digitizing oscilloscope:* Position the digitizing oscilloscope with the top resting on the work surface and the rear panel facing you.
4. *Remove the Power Factor Correction Module:*
 - a. Remove the four screws that secure the module bracket to the rear subpanel.
 - b. Remove the two screws that attach the new air baffle shield. Locate the screws in Figure 6-22. One screw is down in the chassis at the inner edge of the PFC module and the other is up on the edge of the chassis.
 - c. Remove the new air baffle shield.
 - d. Remove the securing hardware from the inner edge of the module mounting bracket, one screw and one hex spacer post. See Figure 6-22 for hardware locations. Do not remove the inner two screws. These two screws secure the circuit board to the mounting bracket.

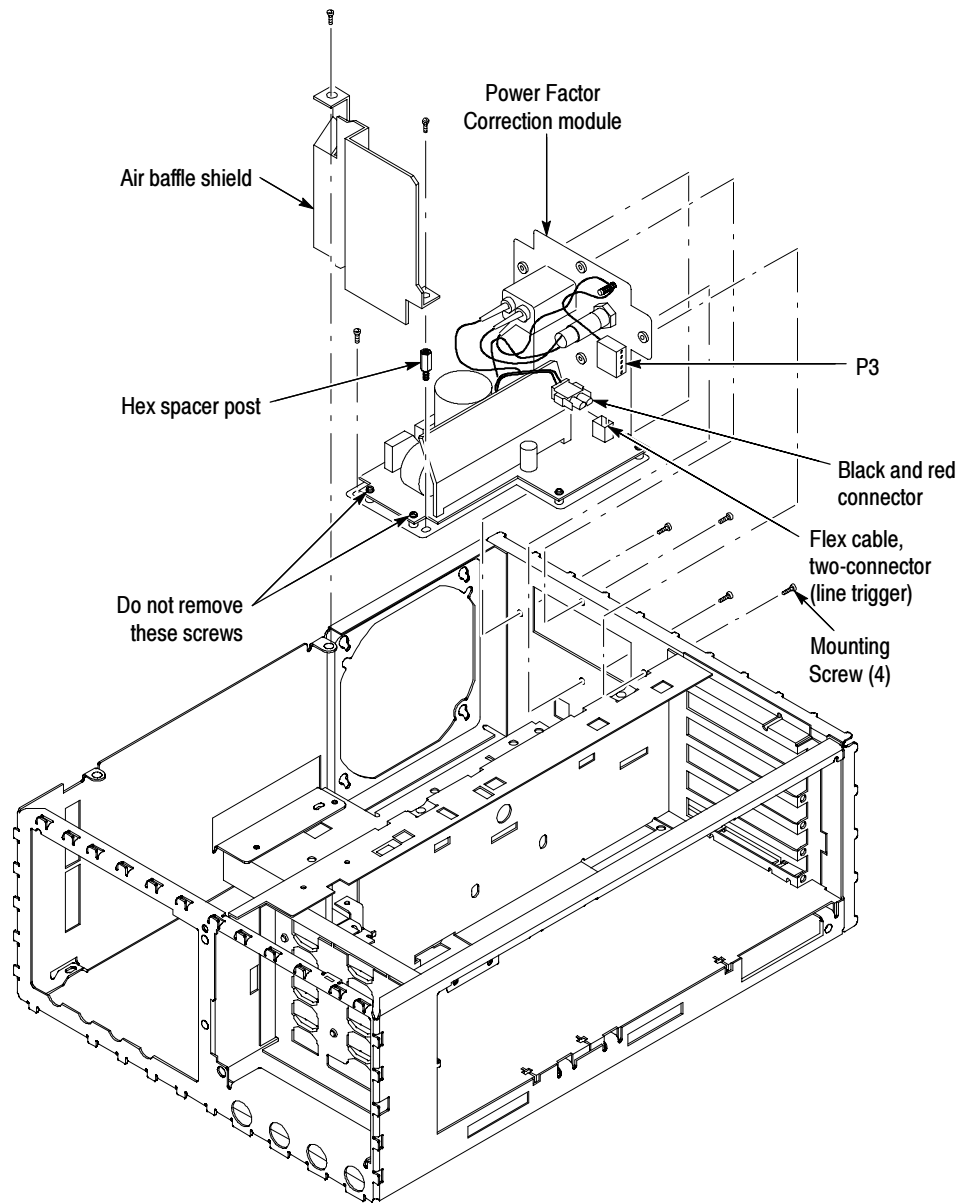

Figure 6-22: Power factor correction module removal, B080000 & up

- e. Disconnect P3 connector located on the low voltage power supply board.
- f. Disconnect the remaining two conductor (black and red) connector located on low voltage power supply board.
- g. Lift the Power Factor Module assembly up and at the same time disconnect the two conductor flex cable (line trigger) from the power supply.

- h. Lift the power-supply mount out of the chassis to complete the removal.

5. *Reinstallation:*

- a. When reinstalling the power-supply mount, be sure to press it flush against the chassis before sliding it towards the bottom of the chassis to lock.
- b. Perform steps 4a through 4h in reverse order.
- c. *Front Cover, Rear Cover, Cabinet, Rear EMI Gasket, and Cabinet Handle and Feet* (page 6-27) to reinstall the cabinet and rear cover.
- d. *Line Fuse and Line Cord* (page 6-26) to reinstall the line cord, which completes the oscilloscope reassembly.

**A25 Low Voltage Power
Supply and its Mount
B080000 & up**

1. *Access the module:* Be sure you have performed the *Access Procedure* on page 6-13 and removed the modules as instructed.
2. *Locate modules to be removed:*
 - a. Use a screwdriver with a size T-15 Torx® tip (Items 1 and 2) and a pair of duck bill pliers (Item 8).
 - b. Find the low voltage power supply and, if it is to be removed, the power-supply mount in the locator diagram *Internal Modules*, Figure 6-3 on page 6-19.
3. *Orient the digitizing oscilloscope:* Set the digitizing oscilloscope so its bottom is down on the work surface and its front is facing to the right.



CAUTION. *When releasing the low voltage power supply from its mount, take care not to push on the board components. Rather, push on the board edge when performing the following step and its substeps.*

4. *Remove the low voltage power supply:*
 - a. Disconnect P2 a 22 square pin connector, power supply cable coming from the backplane assembly.
 - b. Disconnect P3 connector located on the low voltage power supply board.
 - c. Disconnect the remaining two conductor (black and red) connector located on low voltage power supply board.
 - d. Disconnect J3 FAN PWR two conductor (black and red) connector located on the small low voltage power supply board.
 - e. Disconnect J7, 8 conductor flex cable located on the small low voltage power supply board.

- f.** Disconnect J4 CRT PWR two conductor flex cable located on the small low voltage power supply board.
- g.** Working through the opening created when the fan was removed (*Access Procedure*), remove the T-15 Torx® screw at the center of the power supply board.
- h.** Using a pair of duck-bill pliers, squeeze to release each of the four flex locks at the top edge of the low voltage power supply assembly.
- i.** Once released, tilt the board out away from the flex locks.
- j.** Lift the low voltage power supply assembly out of the chassis to complete its removal.

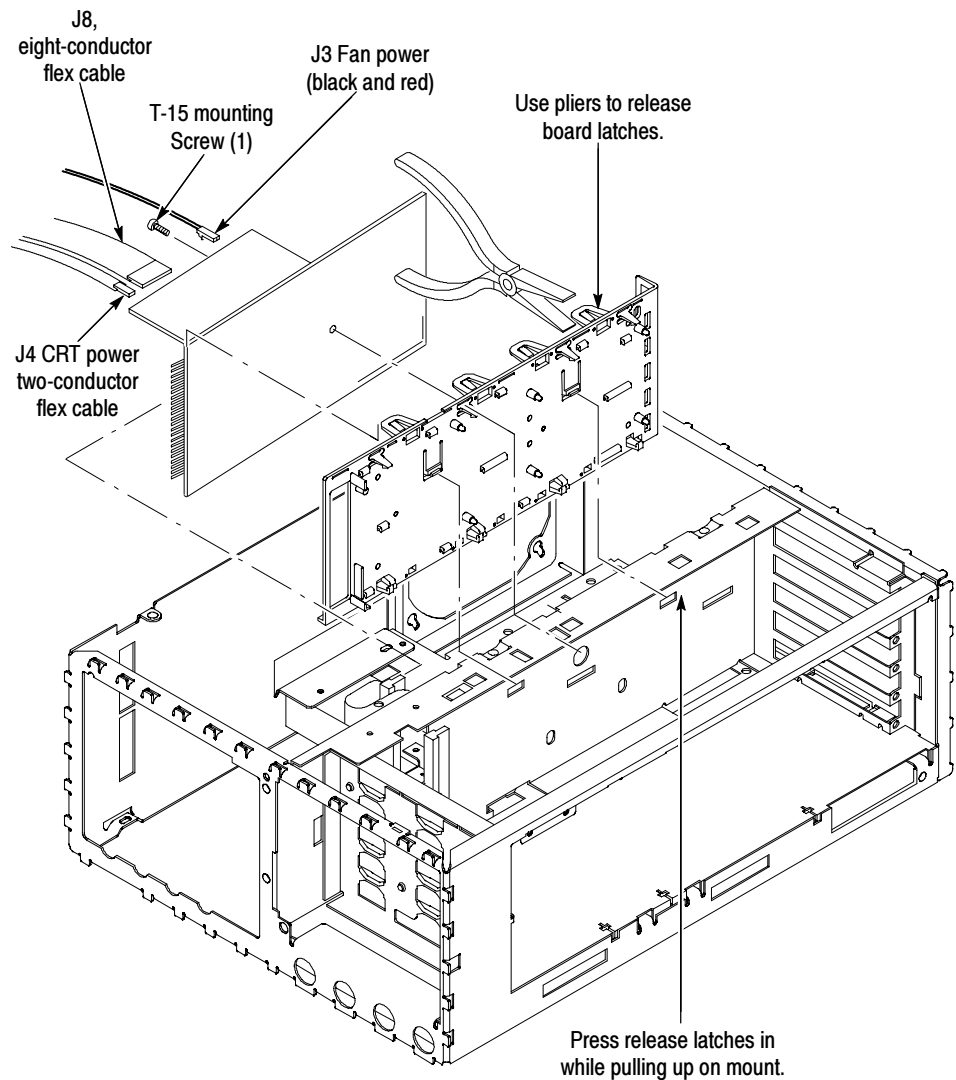

Figure 6-23: A24 Low voltage power supply removal, B080000 & up

5. Reinstallation:

- a. Perform in reverse order substeps 4a-4j, reversing the removal instructions in each substep to reinstall the assembly. *Be sure to seat the board until all of the four flex locks are locked.*
- b. See the following procedures to replace the modules removed by the access procedure.
 - *Front Cover, Rear Cover, Cabinet, Rear EMI Gasket, and Cabinet Handle and Feet* (page 6-27) to reinstall the cabinet and rear cover.

**A25 Low Voltage Power
Supply and its Mount
B010100 to B079999**

- *Line Fuse and Line Cord* (page 6-26) to reinstall the line cord, which completes the oscilloscope reassembly.

1. *Access the module:* Be sure you have performed the *Access Procedure* on page 6-13 and removed the modules as instructed.
2. *Locate modules to be removed:*
 - a. Use a screwdriver with a size T-15 Torx® tip (Items 1 and 2) and a pair of duck bill pliers (Item 8).
 - b. Find the low voltage power supply and, if it is to be removed, the power-supply mount in the locator diagram *Internal Modules*, Figure 6-3 on page 6-19.
3. *Orient the digitizing oscilloscope:* Set the digitizing oscilloscope so its bottom is down on the work surface and its front is facing to the right.



CAUTION. *When releasing the low voltage power supply from its mount, take care not to push on the board components. Rather, push on the board edge when performing the following step and its substeps.*

4. *Remove the low voltage power supply:*
 - a. Unplug the cable coming from the backplane assembly at J2.
 - b. Unplug the cable coming from the AUX power supply at J1.
 - c. Working through the opening created when the fan was removed (*Access Procedure*), remove the T-15 Torx® screw at the center of the power supply board.
 - d. Using a pair of duck-bill pliers, squeeze to release each of the four flex locks at the top edge of the low voltage power supply assembly.
 - e. Once released, tilt the board out away from the flex locks, and unplug the AC power cable where it connects to the cable from the low voltage power supply.
 - f. Lift the low voltage power supply assembly out of the chassis to complete its removal.

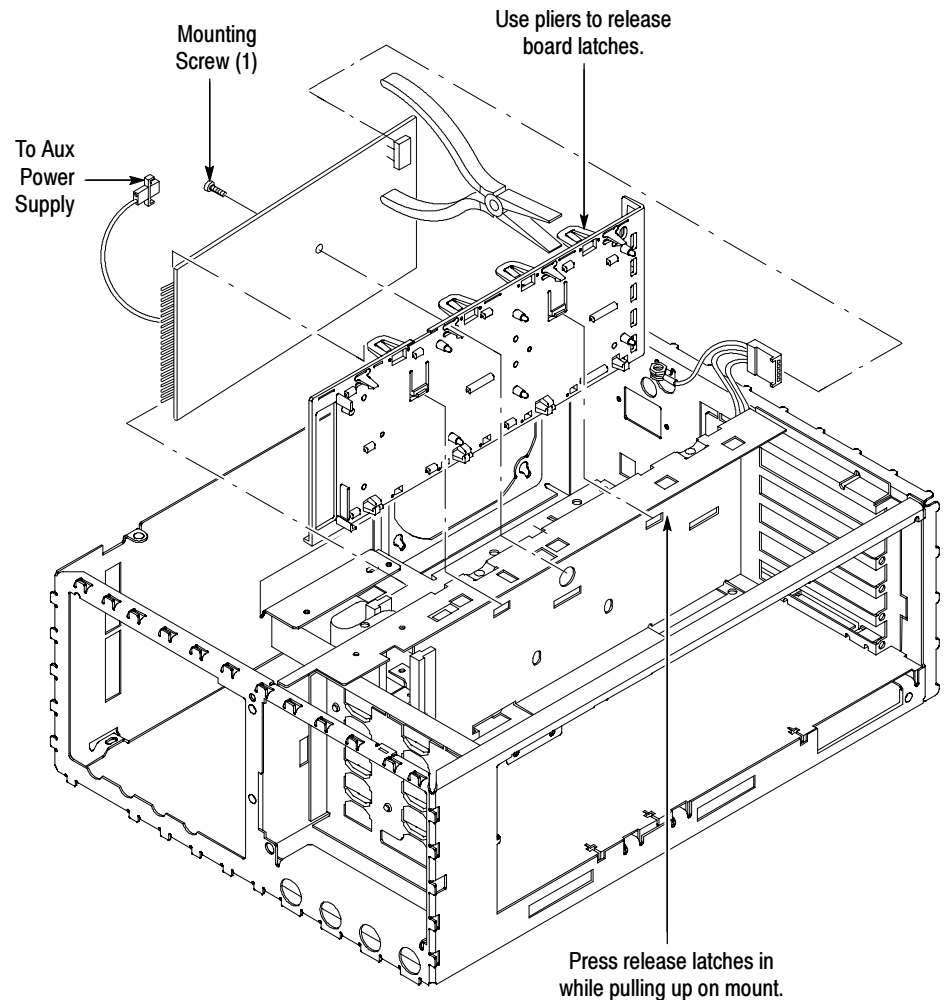

Figure 6-24: A25 Low voltage power supply removal, B010100 - B079999

STOP. DO NOT do step 5 unless servicing a broken power supply mount or removing that mount for cleaning.

5. Remove the power-supply mount:

- a. Place the digitizing oscilloscope so its left side is down with its top facing you.
- b. Depress the two retainer locks and slide the power-supply mount towards the top of the digitizing oscilloscope to unlock from the chassis.

- c. Lift the power-supply mount out of the chassis to complete the removal. When reinstalling the power-supply mount, be sure to press it flush against the chassis before sliding it towards the bottom of the chassis to lock.

6. Reinstallation:

- a. If the power supply mount was removed, do the following subparts:
 - Do in reverse order substeps 5a-5c, reversing the removal instructions in each substep to reinstall the assembly.
 - See *A02 Display Assembly*, on page 6-47, to reinstall that assembly.
 - See *A09 DSP Assembly*, on page 6-48, to reinstall that assembly.
 - See *A03 CPU Assembly*, on page 6-45, to reinstall that assembly.
 - See *A08 Jumper Board Assembly, D1 Bus, and Board Supports* on page 6-44 to reinstall the board supports and D1 bus only.
- b. Perform in reverse order substeps 4a-4j, reversing the removal instructions in each substep to reinstall the assembly. *Be sure to seat the board until all of the four flex locks are locked.*
- c. See the following procedures to replace the modules removed by the access procedure.
 - *Front Cover, Rear Cover, Cabinet, Rear EMI Gasket, and Cabinet Handle and Feet* (page 6-27) to reinstall the cabinet and rear cover.
 - *Line Fuse and Line Cord* (page 6-26) to reinstall the line cord, which completes the oscilloscope reassembly.

Fan and Fan Mount

1. *Access the module:* Be sure you have performed the *Access Procedure* on page 6-13 and removed the modules as instructed.
2. *Assemble equipment and locate modules to be removed:* Locate the modules to be removed in the locator diagram *Internal Modules*, Figure 6-3, page 6-19.
3. *Orient the digitizing oscilloscope:* Set the digitizing oscilloscope so that its bottom is down and its rear is facing you.
4. *Remove the fan:*
 - a. Unplug the power cable for the fan from J3 on the Auxiliary Power Supply.
 - b. Release the two flex locks securing the top of the fan to the fan mount, then lift the fan out from the top of the chassis.
 - c. When reinstalling the fan, be sure the two locks snap into place to secure the fan.

STOP. DO NOT do step 5 unless servicing a broken fan mount or removing that mount for cleaning.

5. *Remove the fan mount:*
 - a. Rotate the digitizing oscilloscope so the side that houses the fan mount is facing upwards.
 - b. Depress the two flex locks to release them (see Figure 6-21).
 - c. While holding the flex locks released, slide the fan mount so its four retainer lugs slide from their small retainer holes in the chassis into their large release holes.
 - d. Move the fan mount inward so its retainer lugs are out of the large retainer holes and lift it out of the chassis to remove.

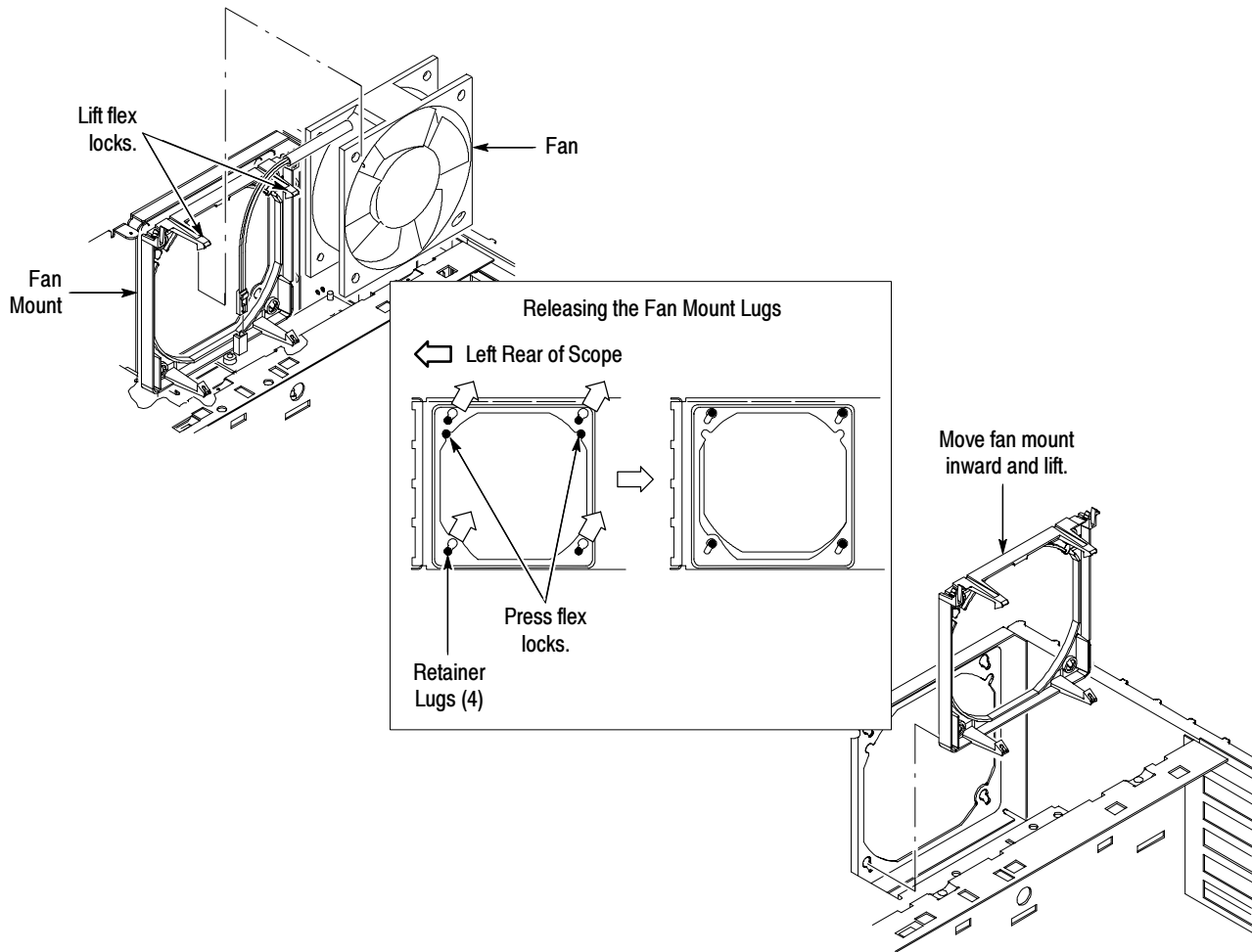

Figure 6-25: Fan and fan mount removal

6. Reinstallation:

- a. If the fan mount was removed, perform in reverse order substeps 5a-5d reversing the removal instructions in each substep to reinstall the fan mount. Be sure to seat the fan mount so its two flex locks snap to secure it on the chassis.
- b. Do in reverse order substeps 4a-4c, to reinstall the fan.
- c. See the following procedures to replace the modules removed by the access procedure:
 - *Front Cover, Rear Cover, Cabinet, Rear EMI Gasket, and Cabinet Handle and Feet* (page 6-27) to reinstall the cabinet and rear cover

- *Line Fuse and Line Cord* (page 6-26) to reinstall the line cord, which completes the oscilloscope reassembly

- Line Filter**
1. *Access the module:* Be sure you have performed the *Access Procedure* on page 6-13 and removed the modules as instructed.
 2. *Assemble equipment and locate modules to be removed:* Have handy a screwdriver with a size T-15 Torx® tip (Items 1 and 2). Locate the line filter in the locator diagram *Internal Modules*, Figure 6-3, page 6-19.
 3. *Orient the digitizing oscilloscope:* Set the digitizing oscilloscope so its bottom is down on the work surface and its rear is facing you.
 4. *Remove the line filter:* Refer to Figure 6-26 when doing the following substeps.
 - a. Unplug the three connectors at the line filter
 - b. Remove the two screws mounting the line filter to the chassis. Pull the filter out through the rear of the chassis to complete the removal.

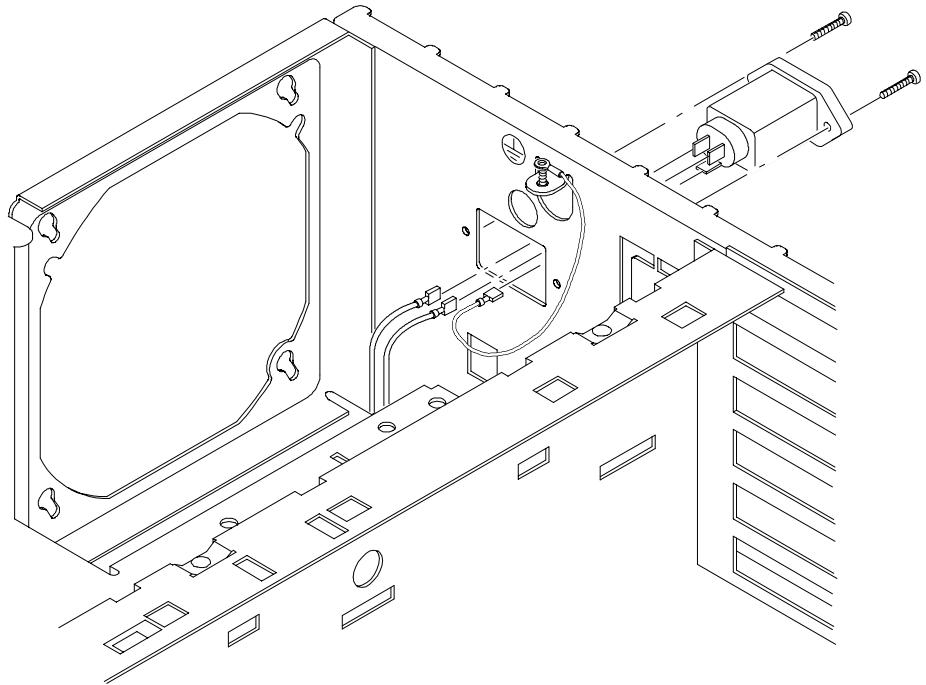

Figure 6-26: Line filter removal

5. *Reinstallation:*



WARNING. *When reconnecting the auxiliary power supply to the line filter, be sure to connect the neutral side of the line filter to the black-striped lead and the load side to the white-striped lead.*

It is not necessary to disconnect the earth ground from the chassis lug that it is bolted to. If, however, you have done so, be sure to install the earth lead (and its nut) from the line filter before installing the earth lead (and its nut) from the low voltage power supply.

- a. Do in reverse order substeps 4a-4b, reversing the removal instructions in each substep to reinstall the assembly.
- b. See the following procedures to replace the modules removed by the access procedure:
 - *Front Cover, Rear Cover, Cabinet, Rear EMI Gasket, and Cabinet Handle and Feet* (page 6-27) to reinstall the cabinet and rear cover
 - *Line Fuse and Line Cord* (page 6-26) to reinstall the line cord, which completes the oscilloscope reassembly

**A07 Auxiliary Power
Supply
B010100 - B079999**

1. *Access the module:* Be sure you have performed the *Access Procedure* on page 6-13 and removed the modules as instructed.
2. *Assemble equipment and locate modules to be removed:*
 - a. Have handy a screwdriver with a size T-15 Torx® tip (Items 1 and 2) and a $\frac{5}{16}$ inch nut-driver (Item 9).
 - b. Locate the auxiliary power supply in the locator diagram *Internal Modules*, Figure 6-3 on page 6-19.
3. *Orient the digitizing oscilloscope:* Set the digitizing oscilloscope so its bottom is down on the work surface and its rear is facing you.
4. *Remove the auxiliary power supply:* Reference Figure 6-27 while doing the following substeps.
 - a. Unplug the monitor-power cable at J4, the fan-power cable at J3, the cable from the backplane assembly at J7, and the cable from the low voltage power supply assembly at J1 of the low voltage power supply assembly.
 - b. Using a $\frac{5}{16}$ inch nut driver remove the nut(s) that secure the cable from the lug and remove it. When replacing the cables on the ground lug, install the cable from the line filter last.
 - c. Now, release and disconnect the remote-power cable where it joins the cable from the low voltage power supply assembly.
 - d. Unplug the two connectors at the line filter.



WARNING. *When reconnecting the auxiliary power supply assembly to the line filter, be sure to connect the neutral side of the line filter to the black-striped lead and the load side to the white-striped lead.*

- e. Remove the two T-15 Torx® screws mounting the auxiliary power supply assembly to the chassis. Then, pull up on the board to release it from the two retainers. Lift the board out of the chassis to complete the removal.

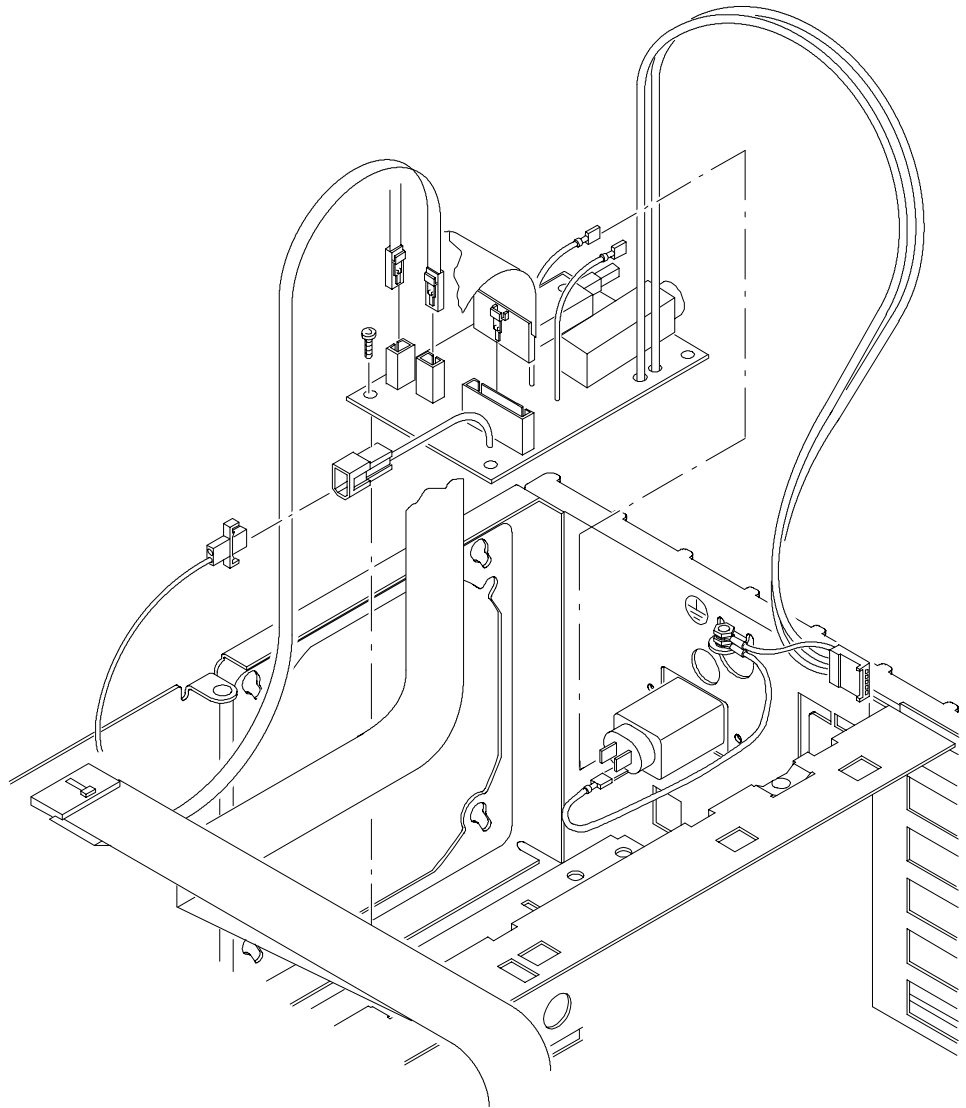

Figure 6-27: Auxiliary power supply removal, B010100 - B079999

5. Reinstallation:

- a.** Perform in reverse order substeps 4a-4e reversing the removal instructions in each substep to reinstall the assembly. Be sure to seat the board until the two mounting posts snap locked on the assembly when reinstalling.

- b. See the following procedures in the order listed to replace modules removed by the access procedure:
 - *A08 Jumper Board Assembly, D1 Bus, and Board Supports* on page 6-44 (board supports and D1 bus only).
 - *A06 Front-Panel Assembly, ESD Shield, and Menu Flex and Probe Code Flex Circuits* on page 6-35.
 - *Trim Ring, Menu Elastomer, Menu Buttons, and Front EMI Gaskets* on page 6-31.
 - *Front Cover, Rear Cover, Cabinet, Rear EMI Gasket, and Cabinet Handle and Feet* (page 6-27) to reinstall the cabinet and rear cover.
 - *Line Fuse and Line Cord* (page 6-26) to reinstall the line cord, which completes the oscilloscope reassembly.

A04 Acquisition Assembly

1. *Access the module:* Be sure you have performed the *Access Procedure* on page 6-13 and removed the modules as instructed.
2. *Assemble equipment and locate modules to be removed:* Have handy a screwdriver with a size T-15 Torx® tip (Items 1 and 2). Locate the acquisition assembly in the locator diagram *Internal Modules*, Figure 6-3 on page 6-19.
3. *Orient the digitizing oscilloscope:* Set the digitizing oscilloscope so its bottom is up, with its front facing you.
4. *Remove the acquisition assembly:* Use Figure 6-28 as a guide.
 - a. Unplug the cable from the backplane assembly from J7 of the acquisition assembly.
 - b. Unsolder the wire from the AUX TRIGGER/EXT CLOCK BNC.
 - c. Remove the six screws securing the acquisition assembly to the bottom of the chassis, and lift out the acquisition assembly to complete its removal.

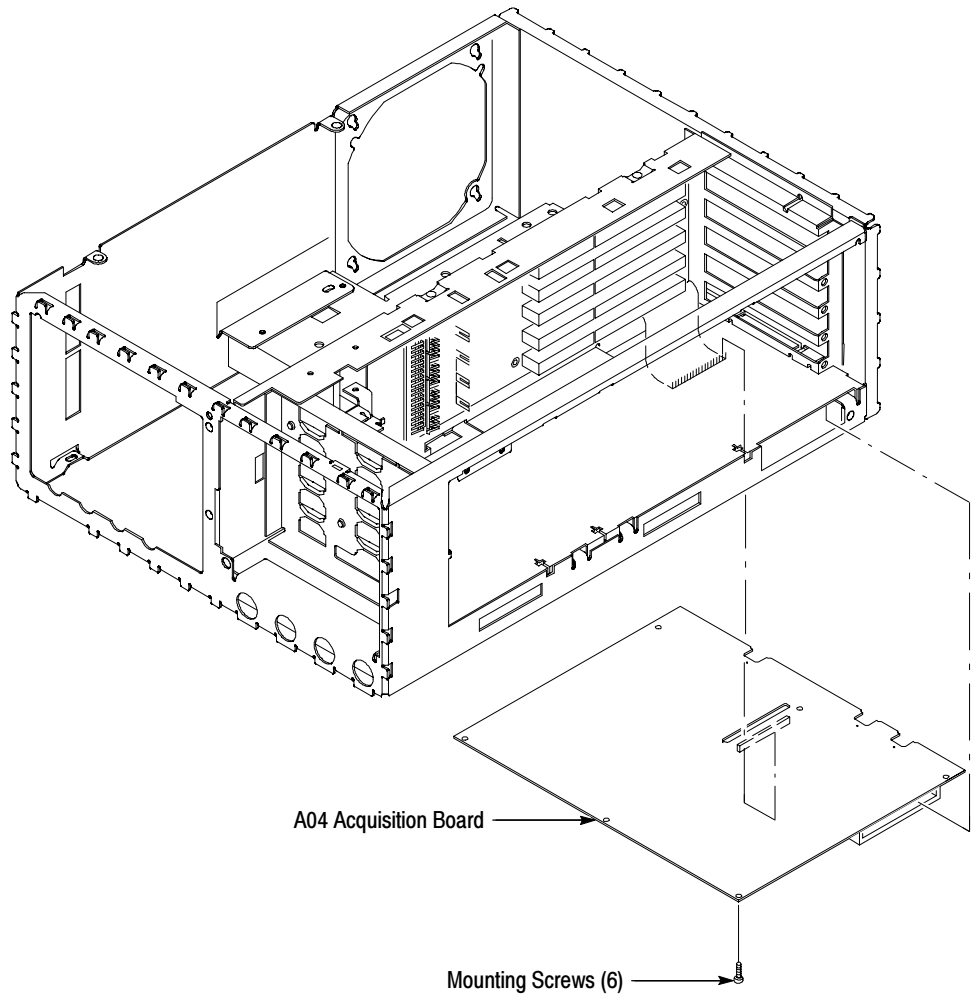

Figure 6-28: A04 Acquisition Board Removal

5. Reinstallation:

- a. Perform in reverse order substeps 4a-4c reversing the removal instructions in each substep to reinstall the assembly.
- b. See the following procedures in the order listed to replace modules removed by the access procedure:
 - *A08 Jumper Board Assembly, D1 Bus, and Board Supports* on page 6-44 to install the jumper board and D1 bus only
 - *Front Cover, Rear Cover, Cabinet, Rear EMI Gasket, and Cabinet Handle and Feet* (page 6-27) to reinstall the cabinet and rear cover
 - *Line Fuse and Line Cord* (page 6-26) to reinstall the line cord, which completes the oscilloscope reassembly

- Main Chassis**
1. *Remove the main chassis:* Since the removal of the *main chassis* requires the removal of virtually all modules, perform the procedure *Disassembly for Cleaning* that follows.
 2. *Reinstallation:* See reinstallation instructions in *Disassembly for Cleaning*.

Disassembly for Cleaning

This procedure is for disassembly of the digitizing oscilloscope into its individual modules so they can be cleaned. Read the cleaning instructions in *Inspection and Cleaning* on page 6-4 before disassembling this oscilloscope.

1. *Assemble equipment and locate modules to be removed:*
 - a. Have handy a screwdriver with a size T-15 Torx® tip (Items 1 and 2), a T-20 Torx® tip (Item 3), a flat-bladed screwdriver (Item 5), a pair of angle-tip tweezers (Item 10), duck bill pliers (Item 8), flat bladed spudger (Item 11), and a soldering iron (Item 12).
 - b. Familiarize yourself with the modules illustrated in Figures 6-2, 6-3, and 6-4 on pages 6-16, 6-19, and 6-22 respectively.
2. *Remove all modules:* Do, in the order listed the following procedures. They are found under *Procedures for Module Removal and Installation* which starts on page 6-23.
 - a. *Line Fuse and Line Cord* (page 6-26)
 - b. *Front Cover, Rear Cover, Cabinet, Rear EMI Gasket, and Cabinet Handle and Feet* (page 6-27)
 - c. *Disk Drive* (page 6-34)
 - d. *Trim Ring, Menu Elastomer, Menu Buttons, and Front EMI Gaskets* (page 6-31)
 - e. *A06 Front-Panel Assembly, ESD Shield, and Menu Flex and Probe Code Flex Circuits* (page 6-35)
 - f. *Fan and Fan Mount* (page 6-63)
 - g. *A25 Low Voltage Power Supply and its Mount* (page 6-57)
 - h. *A26 Monitor Assembly* (page 6-41)
 - i. *A07 Auxiliary Power Supply B010100 - B079999* (page 6-67)
 - j. *Line Filter* (page 6-65)

- k. *A08 Jumper Board Assembly, D1 Bus, and Board Supports* (page 6-44)
 - l. *A03 CPU Assembly* (page 6-45)
 - m. *A02 Display Assembly* (page 6-47)
 - n. *A09 DSP Assembly* (page 6-48)
 - o. *A01 Backplane Assembly and its Mount* (page 6-50)
 - p. *Back-up Batteries* (page 6-53)
 - q. *A05 Attenuator Assembly and Shield* (page 6-39)
 - r. *A04 Acquisition Assembly* (page 6-69)
3. *Reassembly*: Do substeps a-r in the order listed. Observe the following instructions as you do them:
- The procedures called out in the substeps that follow reinstall all the modules. When doing these procedures, do their steps in reverse order.
 - When reinstalling the modules, ignore any instructions that require connecting a cable or bus to a module that you have not yet installed. You will make the necessary connections when you install the missing module later.
 - Ignore any instructions to do the *Access Procedure*. The access procedure is only used when removing individual modules for servicing, not when doing a disassembly/reassembly for cleaning.
 - Ignore any instructions directing you to see other procedures to reinstall modules removed by the access procedure. The substeps that follow direct you to the procedures needed to reinstall all of the modules.
- a. *A04 Acquisition Assembly* (page 6-69)
 - b. *A05 Attenuator Assembly and Shield* (page 6-39)
 - c. *Back-up Batteries* (page 6-53)
 - d. *A01 Backplane Assembly and its Mount* (page 6-50)
 - e. *A09 DSP Assembly* (page 6-48)
 - f. *A02 Display Assembly* (page 6-47)
 - g. *A03 CPU Assembly* (page 6-45)
 - h. *Line Fuse and Line Cord* (page 6-26)
 - i. *A08 Jumper Board Assembly, D1 Bus, and Board Supports* (page 6-44)
 - j. *Line Filter* (page 6-65)

- k.** *A07 Auxiliary Power Supply
B010100 - B079999 (page 6-67)*
- l.** *A26 Monitor Assembly (page 6-41)*
- m.** *A25 Low Voltage Power Supply and its Mount (page 6-57)*
- n.** *Fan and Fan Mount (page 6-63)*
- o.** *Trim Ring, Menu Elastomer, Menu Buttons, and Front EMI Gaskets
(page 6-31)*
- p.** *Disk Drive (page 6-34)*
- q.** *A06 Front-Panel Assembly, ESD Shield, and Menu Flex and Probe Code
Flex Circuits (page 6-35)*
- r.** *Front Cover, Rear Cover, Cabinet, Rear EMI Gasket, and Cabinet
Handle and Feet (page 6-27)*
- s.** *Line Fuse and Line Cord (page 6-26)*

Troubleshooting

This section contains information and procedures designed to help you isolate faulty modules in the oscilloscope. If a module needs to be replaced, follow the *Removal and Installation Procedures* located on page 6-9. If servicing a TDS 430A, follow the procedures for the TDS 460A, but ignore all references to CH 3 and CH 4.



CAUTION. *This oscilloscope operates over several ranges of line voltage (see Source Voltage and Frequency on page NO TAG of Chapter 1, Specification). Before stepping the line voltage from one range to a higher range, set the principal power switch (rear panel) to its OFF position. Failure to do so can damage the oscilloscope.*

Diagnostics

The oscilloscope has two levels of internal diagnostics that focus on verifying, adjusting, and, if need be, isolating faulty modules.

Both levels of internal diagnostics report any bad modules or interfaces. If the diagnostics do find a bad module or interface, use the troubleshooting procedures in this section to determine which module needs to be replaced.

The two levels of diagnostics are the short confidence set and an extended set that tests the oscilloscope circuitry in-depth and takes more time. At power-on, the oscilloscope automatically executes the short set. The extended set is optional and is executed by using the following procedure:

Prerequisites: Power up the oscilloscope and allow a 20 minute warm-up before doing this procedure.

1. *Display the System diagnostics menu:*
 - a. Press **SHIFT**; then press **UTILITY**.
 - b. Repeatedly press the main-menu button **System** until **Diag/Err** is highlighted in the menu that pops up.
 - c. Repeatedly press the main-menu button **Area** until **All** is highlighted in the menu that pops up.
2. *Run the System Diagnostics:* Press the main-menu button **Execute**; then press the side-menu button **OK Confirm Run Test**.



3. *Wait:* The internal diagnostics do an exhaustive verification of proper oscilloscope function. This verification takes about two minutes. When finished, the oscilloscope displays a report of any bad modules or interfaces.

Firmware Updates

Firmware updates are easy to do. Simply install the firmware disks on your PC and follow the instructions in the README file located on the first disk. The firmware update kit is listed as an optional accessory in Chapter 10.

NOTE. You must set both switches of the Protection switch to the unprotected position before updating the firmware. Figure 6-29 shows how to set the switch. After loading the firmware, be sure you set both switches back to the protected position and cycle power.

If you want to order a firmware update, see *Optional Accessories* in Chapter 10 *Mechanical Parts List* for the part number.

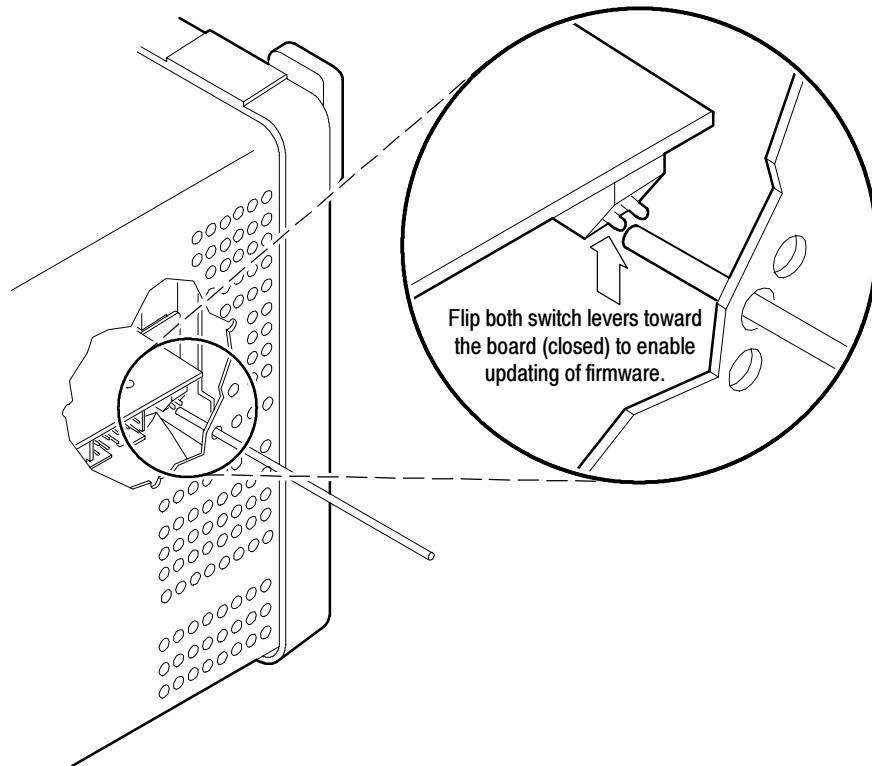

Figure 6-29: Accessing the protection switch

Troubleshooting Equipment

Equipment listed in Tables 4-1, 5-3, 6-4, and 6-8 of this manual, or equivalent equipment, may be useful while troubleshooting this oscilloscope. Construction of and set-up of other troubleshooting equipment are also listed in this section.

Table 6-8: Troubleshooting Test Equipment, Fixtures, and Supplies

Item Number and Description	Minimum Requirements	Example	Purpose
1. Console Port	Tektronix part number 174-2613-00	Tektronix part number 174-2613-00 (see Figure 6-30 on page 6-79)	Troubleshooting using the Console Port
2. Computer	IBM® PC compatible		Troubleshooting using the Console Port
3. Extension cable	Console port to computer connection		Troubleshooting using the Console Port
4. Telecommunication software	RS-232, 9600 baud	Cross Talk®	Troubleshooting using the Console Port
5. Oscilloscope	200 MHz (for the TDS 420A) or 400 MHz (for the TDS 430A and TDS 460A) digitizing oscilloscope	TEKTRONIX TDS 430A, TDS 420A, or TDS 460A	General troubleshooting

Console Port Set Up

The console port allows you to see detailed diagnostic messages when faults in the oscilloscope prevent display of the normal diagnostics. Use this procedure to set up the console port:

NOTE. You may need a DB-9 to DB-25 adaptor, null modem adaptor, gender changer adaptor, and an extension cable to connect the console port to your personal computer (see Figure 6-30 on page 6-30). Using Table 6-9 as a guide you can wire a cable to take the place of a DB9 to DB25 adaptor, null modem adaptor, gender changer, and an extension cable.

1. *Equipment required:* Console port (Item 1), a personal computer or terminal (Item 2), and telecommunication (terminal) software (Item 4) for the personal computer. Your personal computer may also require a DB-9 to DB-25 adaptor, null modem adaptor, gender changer adaptor, and an extension cable to connect the console port to your personal computer (see Figure 6-30 on page 6-79).
2. *Prerequisites:* Power off the oscilloscope.

3. *Accessing J3:* Using the *Front Cover, Rear Cover, Cabinet, Rear EMI Gasket, and Cabinet Handle and Feet* disassembly procedure, remove the cabinet.

Table 6-9: Connections for a 9 to 25 Pin Null Modem Cable

DB-9 Signals	DB-9 Pin	DB-25 Pin	DB-25 Signals
DCD	1	20	DTR
RD	2	2	TD
TD	3	3	RD
DTR	4	6 and 8	DSR and DCD
SG	5	7	SG
DSR	6	20	DTR
RTS	7	5	CTS
CTS	8	4	RTS
Unused (RI)	9	-	All Others Unused

4. *Connecting the equipment:* Attach the console-port cable to J3 on the A03 CPU module (see Figure 6-30) and, using an extender cable or adaptors, to the RS-232 serial port of your personal computer (or RS-232 terminal).
5. *Configure the personal computer:*
 - a. *Load the software:* Load telecommunication (terminal) software into your personal computer.
 - b. *Select the software port:* Configure the telecommunication software so that it accesses the serial port that you connected to the console port (Com1 or Com2).
 - c. *Configure port parameters:* Set the telecommunication software (or terminal) parameters:
 - Baud Rate 9600
 - Parity None
 - Data Bits 8
 - Stop Bits 1
 - Duplex Full
 - Protocol None

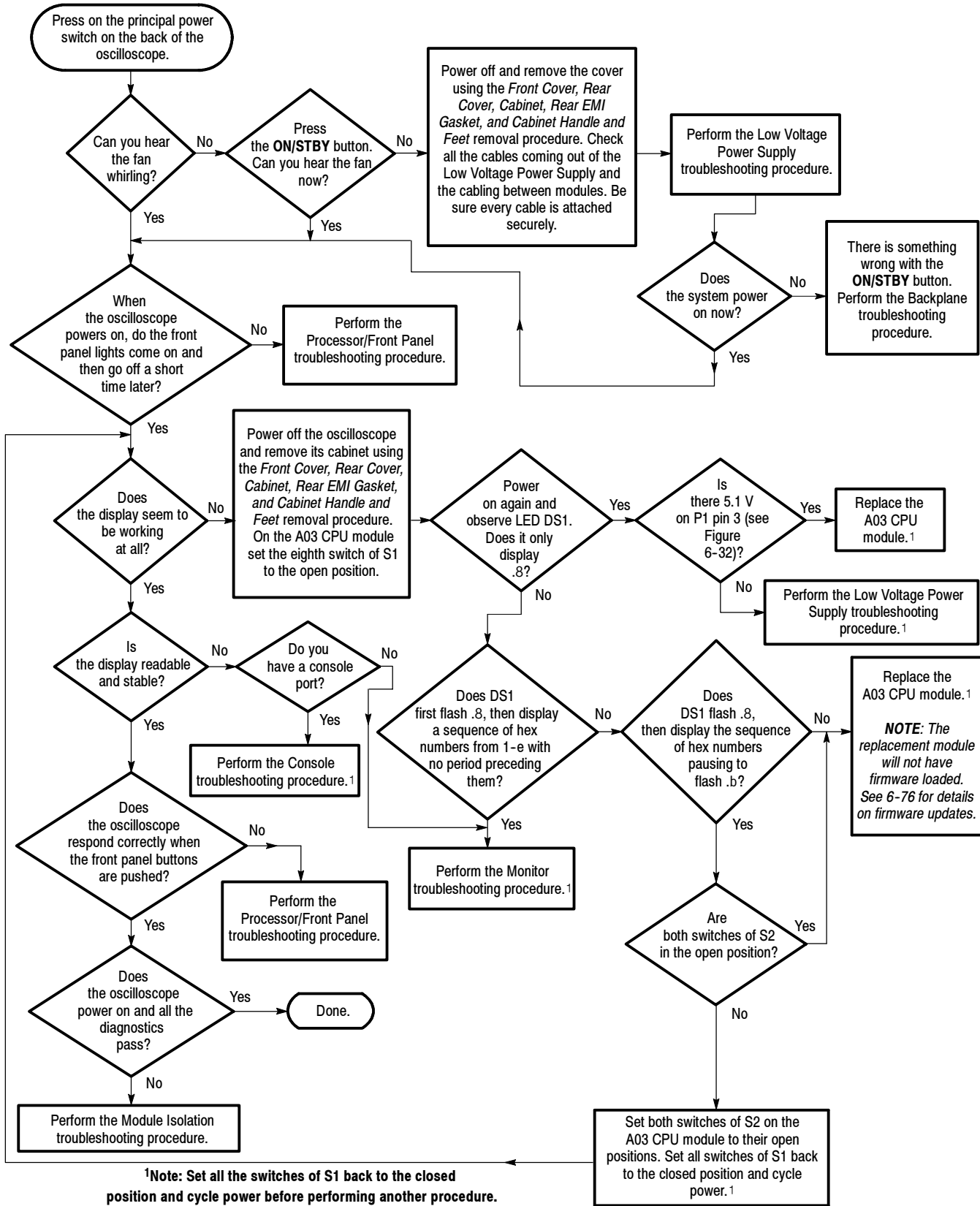

Figure 6-31: Primary Troubleshooting Procedure

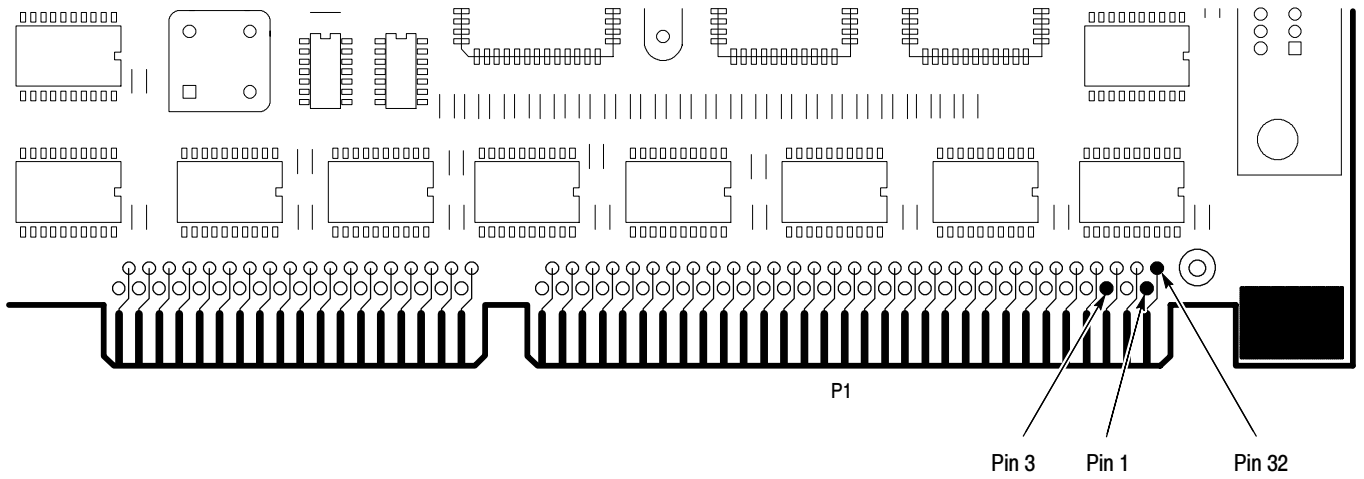

Figure 6-32: A03 CPU Board Connector P1

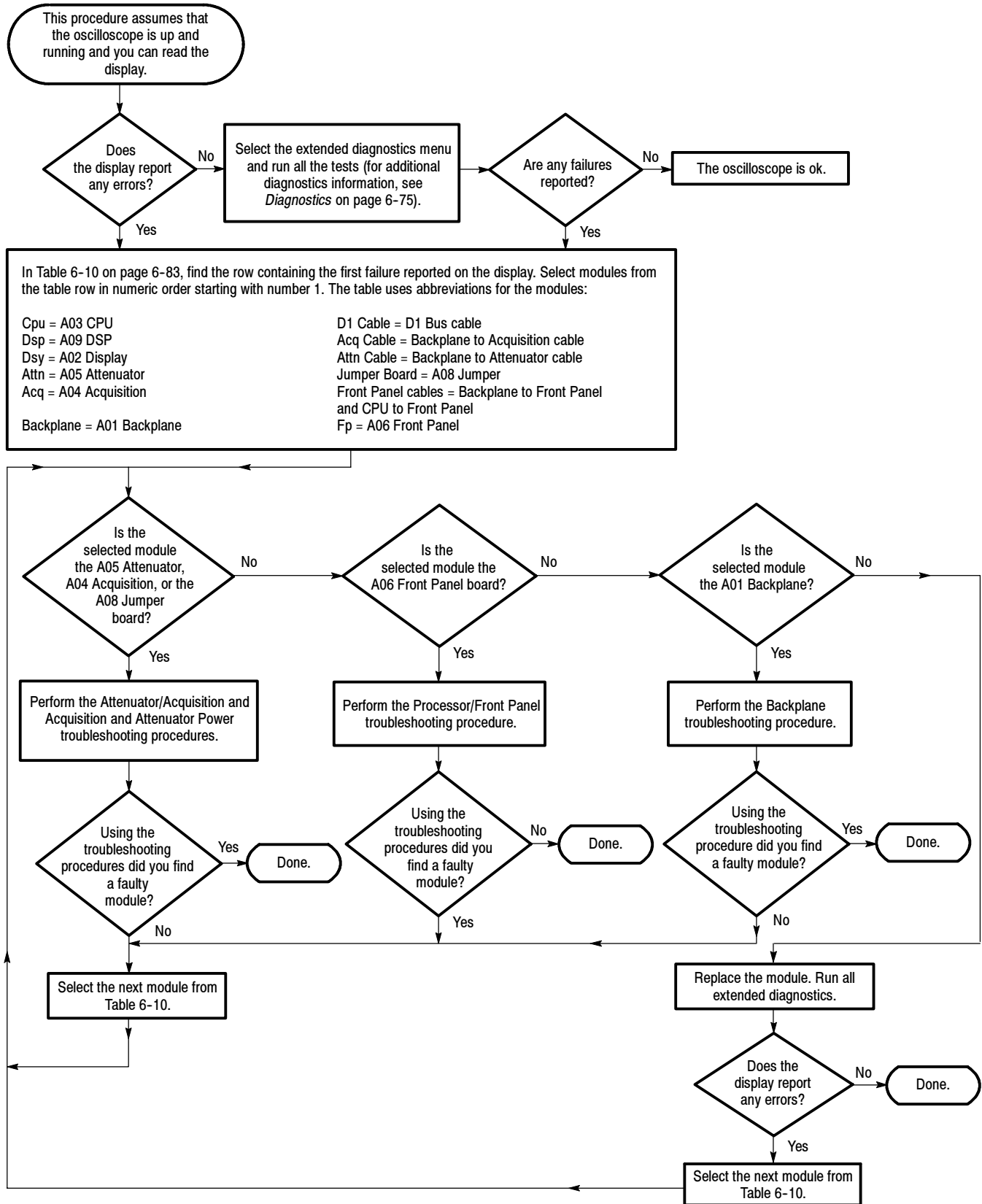

Figure 6-33: Module Isolation Troubleshooting Procedure

Table 6- 10: Diagnostic Failure Priority Lists

Module	Cpu	Dsp	Dsy	Attn	Acq	Back-plane	D1 Cable	Acq Cable	Attn Cable	Attn/ Acq Jumper Board	Front Panel Cables	Fp
Cpu	1	2	3			4	5					
Cal Initialization	1											
Cpu/Dsp or AT bus	2	1	3			4						
Dsp		1	2		4		3					
Cpu/Dsp/Dsy or D1 bus		3	1		4		2					
Cpu/Dsp/Dsy or AT bus	1	2	3			4						
Dsy		3	1		4		2					
Cpu/Attn or I2C bus	2			1	4	3			3			
Attn				1	3	2						
Cpu/Acq, D1/I2C bus	5	4			1		2	3				
Acq				3	1	4	5			2		
Acq/Attn				2	3		4			1		
Fp/Cpu	3										2	1

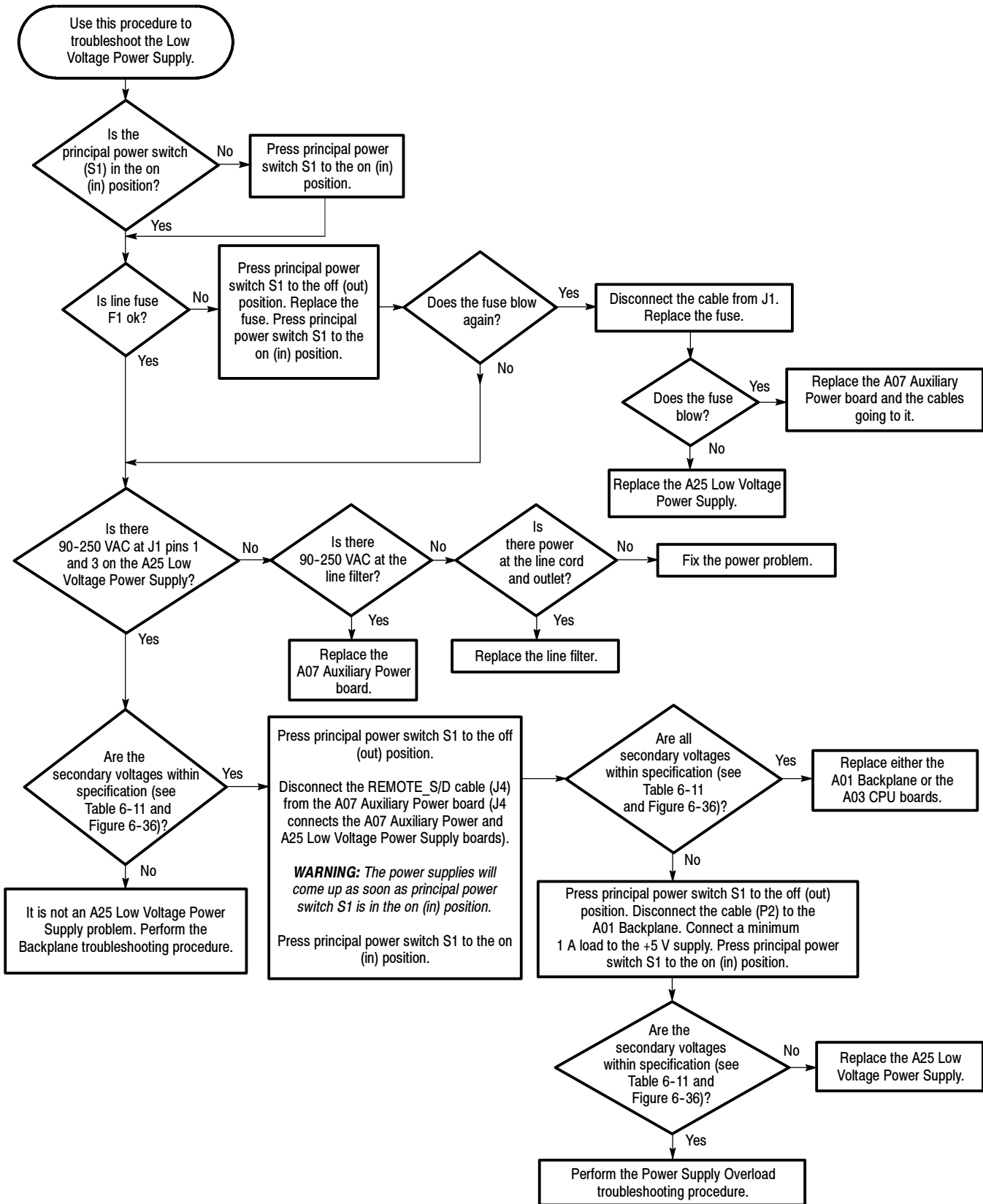

Figure 6-34: Low Voltage Power Supply Troubleshooting Procedure

Table 6- 11: Normal Output Voltage

Supply	J2 Pin	Minimum Output	Maximum Output
+5.1 V	20	+5.05 V	+5.15 V
+15 V	8	+14.85 V	+15.15 V
-6.4 V	6	-6.35 V	-6.45 V
-15 V	2	-14.85 V	-15.15 V

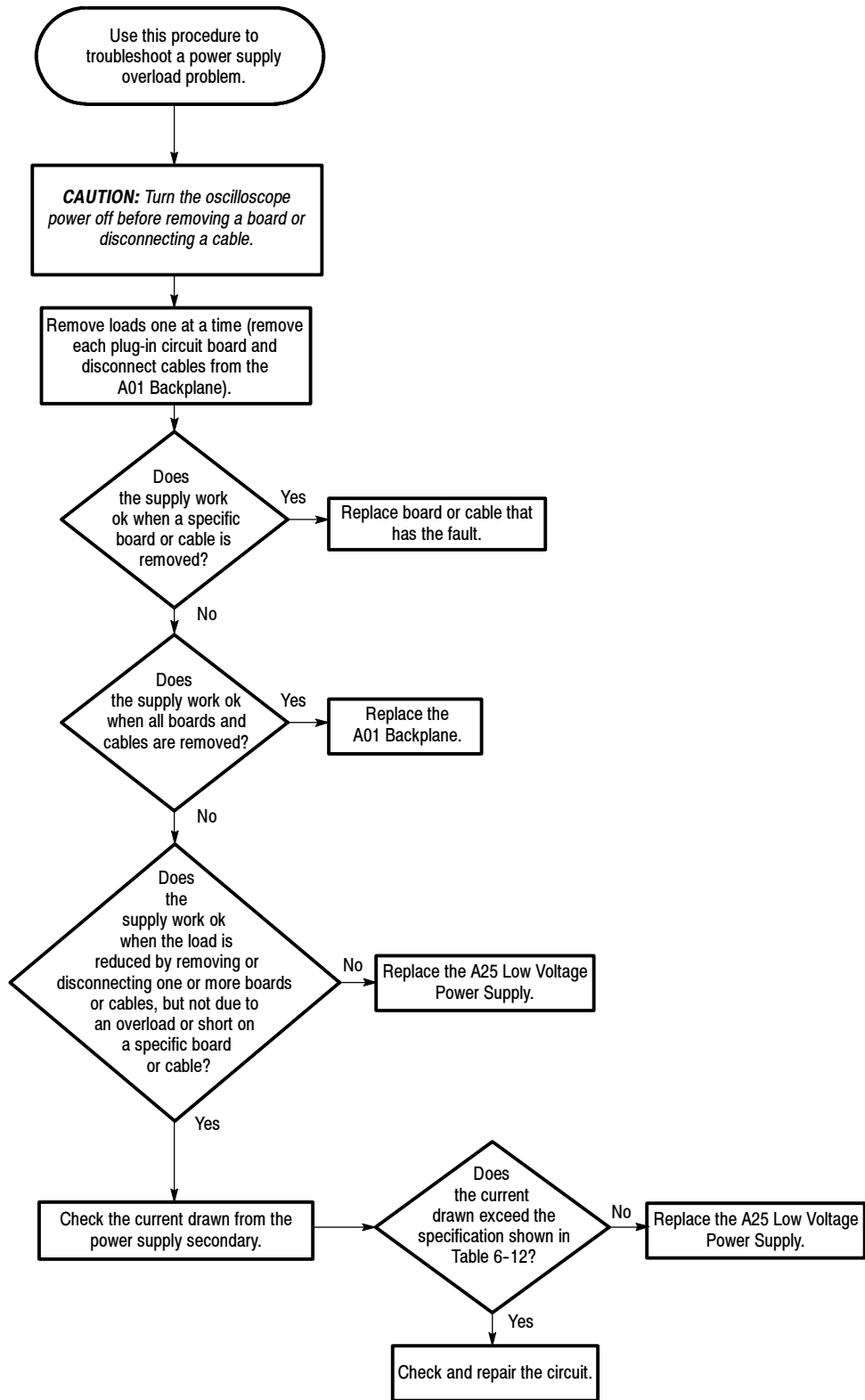

Figure 6- 35: Power Supply Overload Troubleshooting Procedure

Table 6-12: Power Supply Maximum Current

Supply	J2 Pins	Maximum Current
+5.1 V	16-20	15 A
+15 V	8 and 9	3.5 A
-6.4 V	6 and 7	5.5 A
-15 V	1 and 2	0.75 A

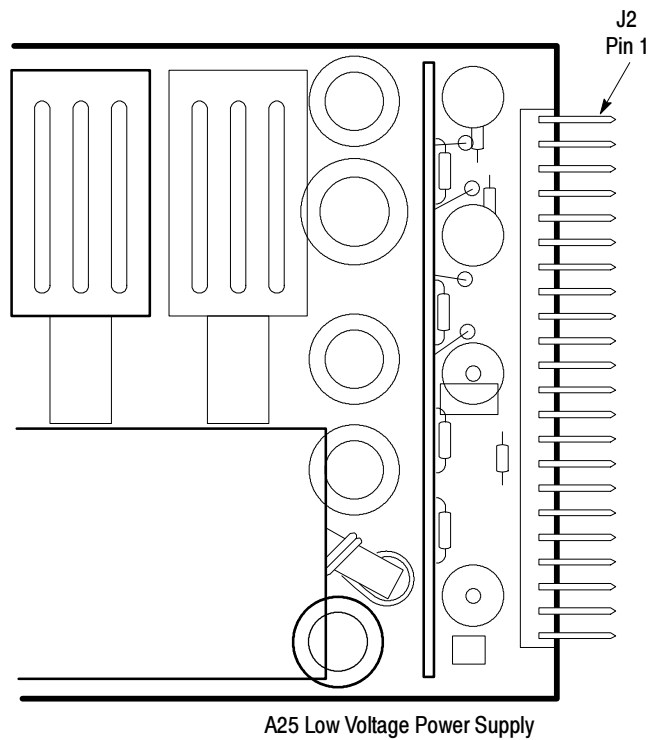

Figure 6-36: A25 Low Voltage Power Supply Module (Right Side)

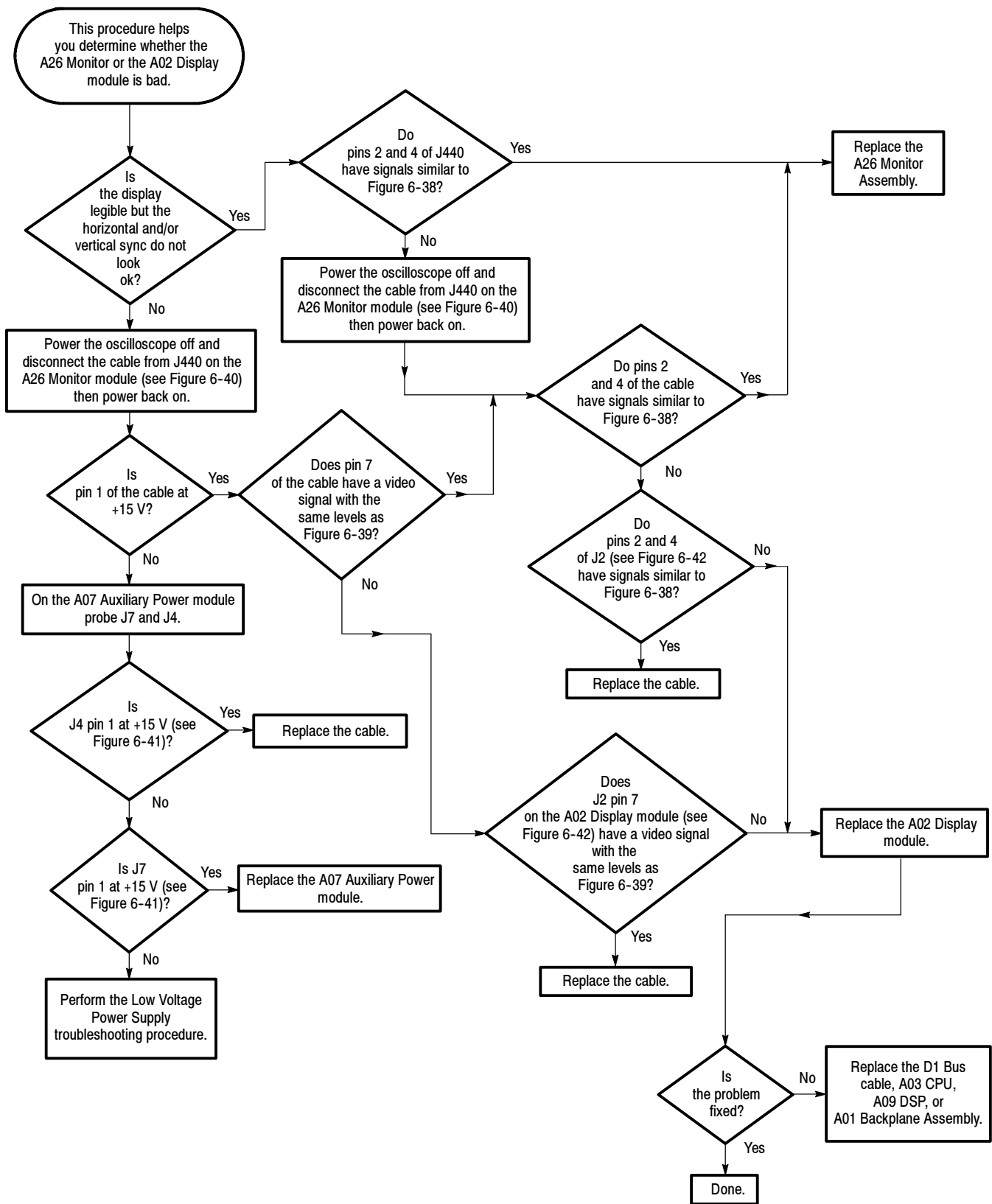

Figure 6-37: Monitor Troubleshooting Procedure

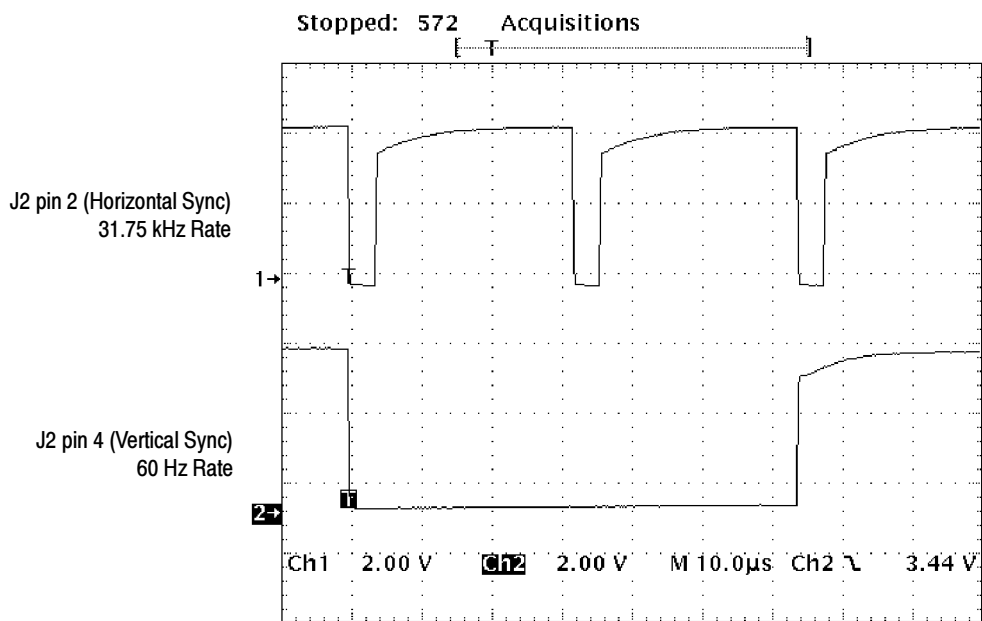

Figure 6-38: Horizontal and Vertical Sync Signals

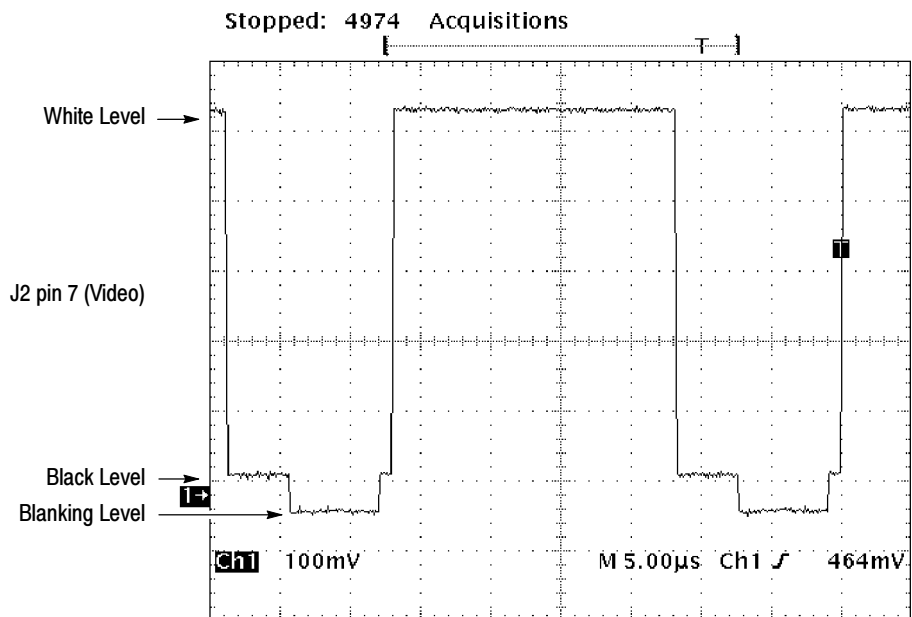

Figure 6-39: A Video Signal with White, Black, and Blanking Levels

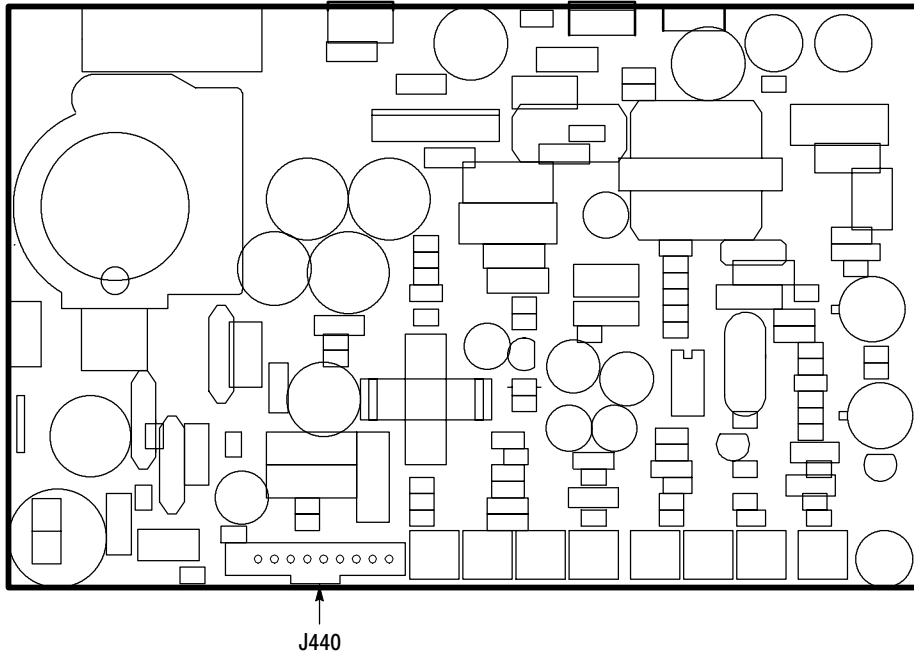

Figure 6-40: A26 Monitor Connector J440

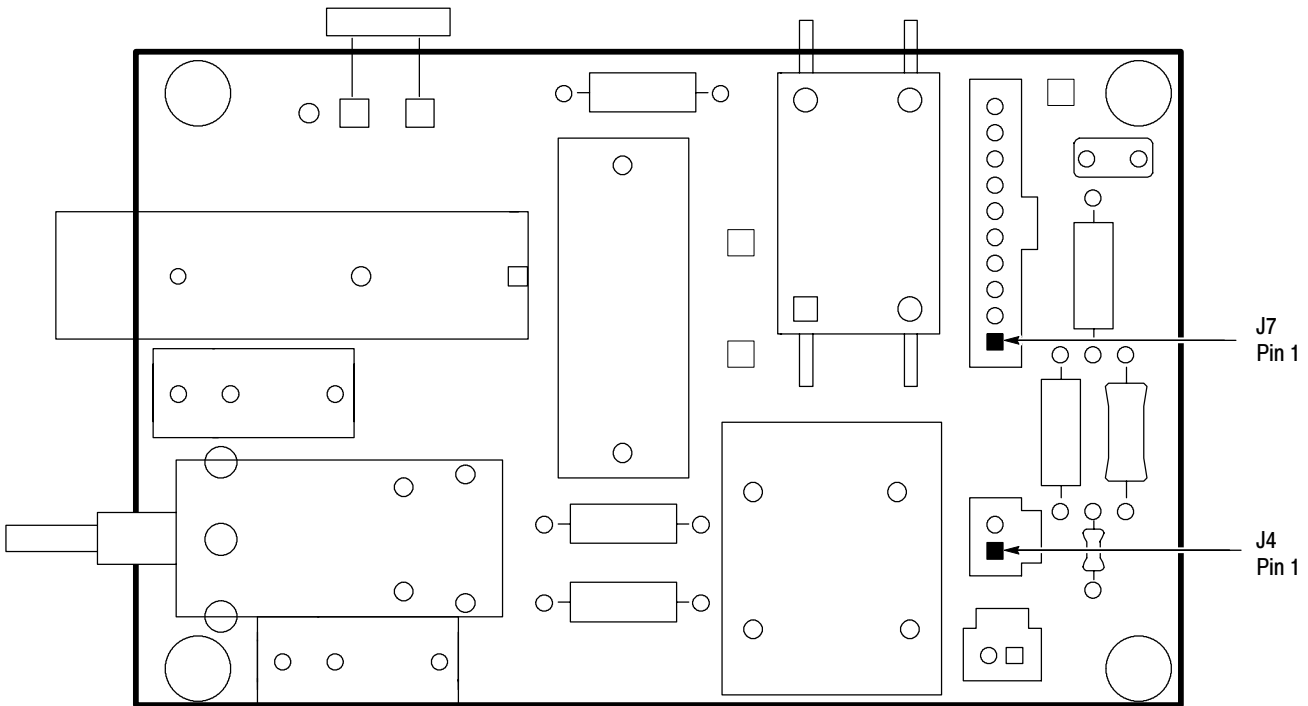

Figure 6-41: A07 Auxiliary Power Connectors J4 and J7

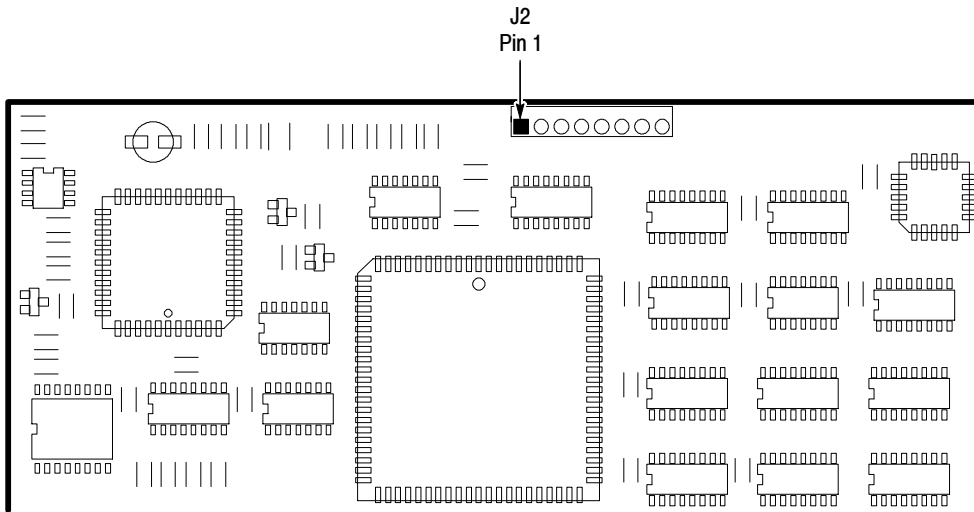

Figure 6-42: A02 Display Connector J2

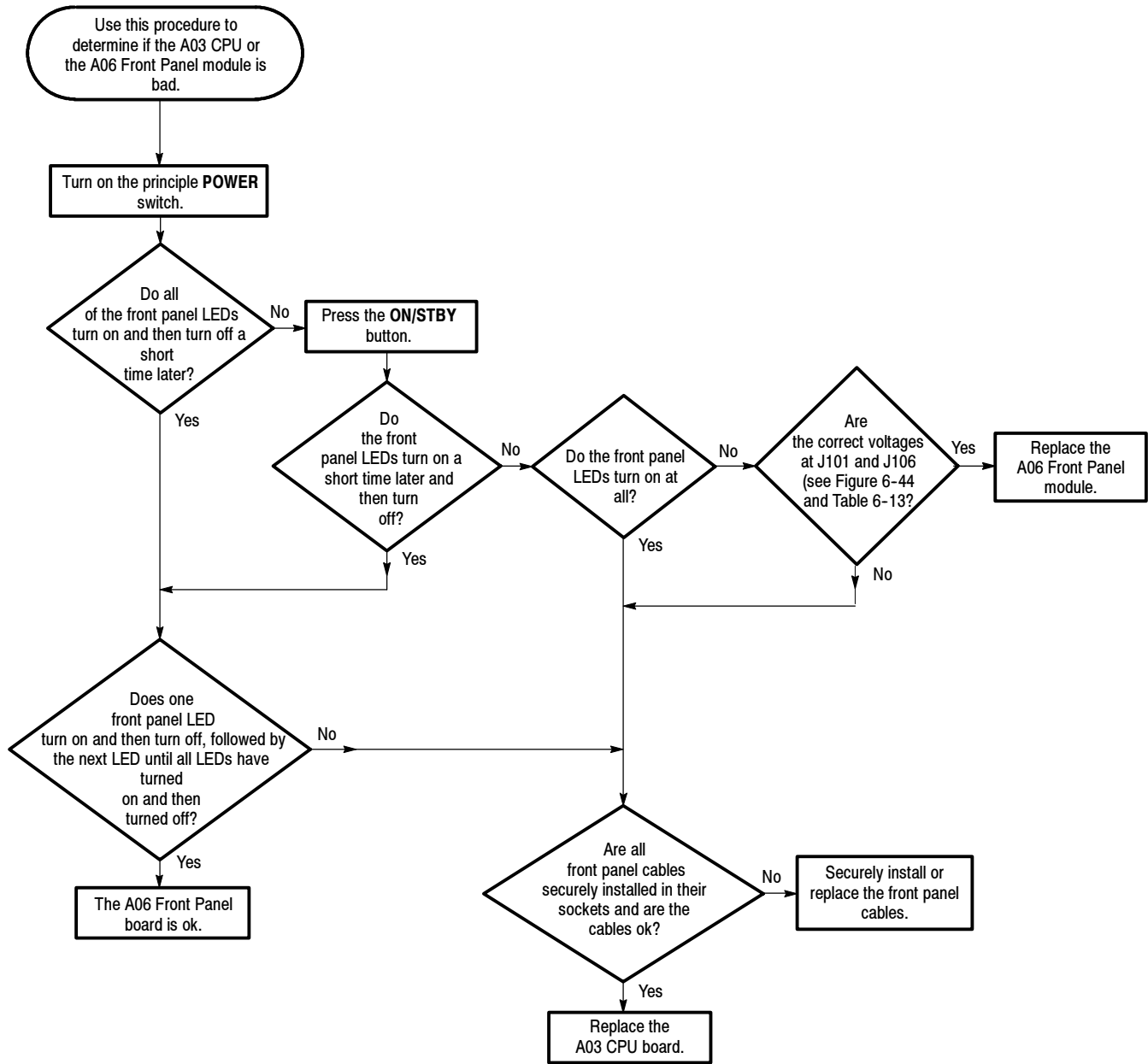

Figure 6-43: Processor/Front Panel Troubleshooting Procedure

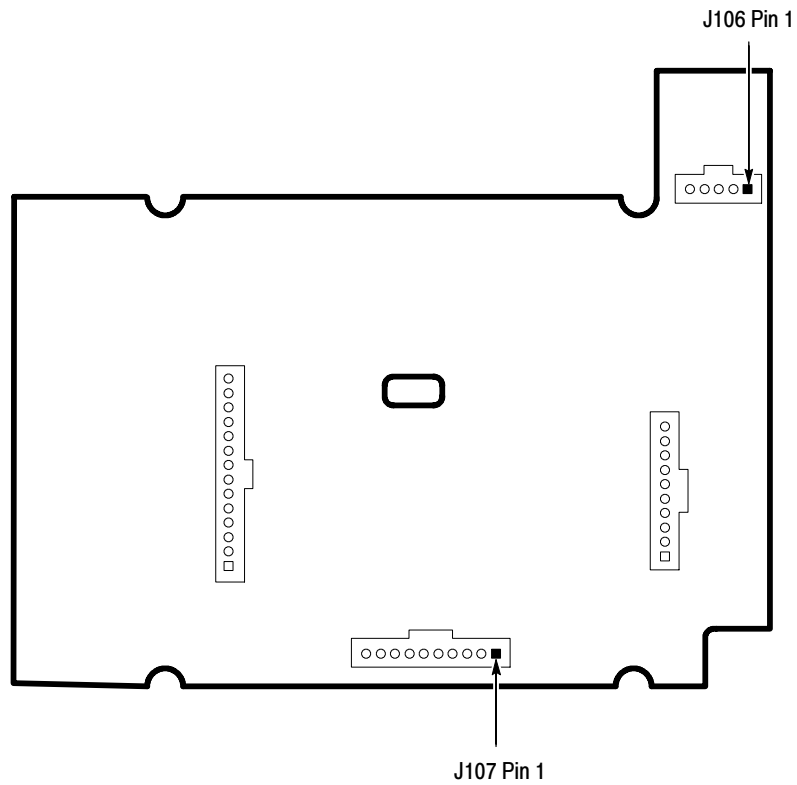

Figure 6-44: A06 Front Panel Board Power Connectors J101 and J106

Table 6-13: Front Panel Connector Voltages

Connector	Pin	Nominal Voltage
J101	Pins 2 and 4	5.1 V
J106	Pin 1	15 V
J106	Pin 2	5.1 V
J106	Pin 4	-5 V
J106	Pin 5	-15 V

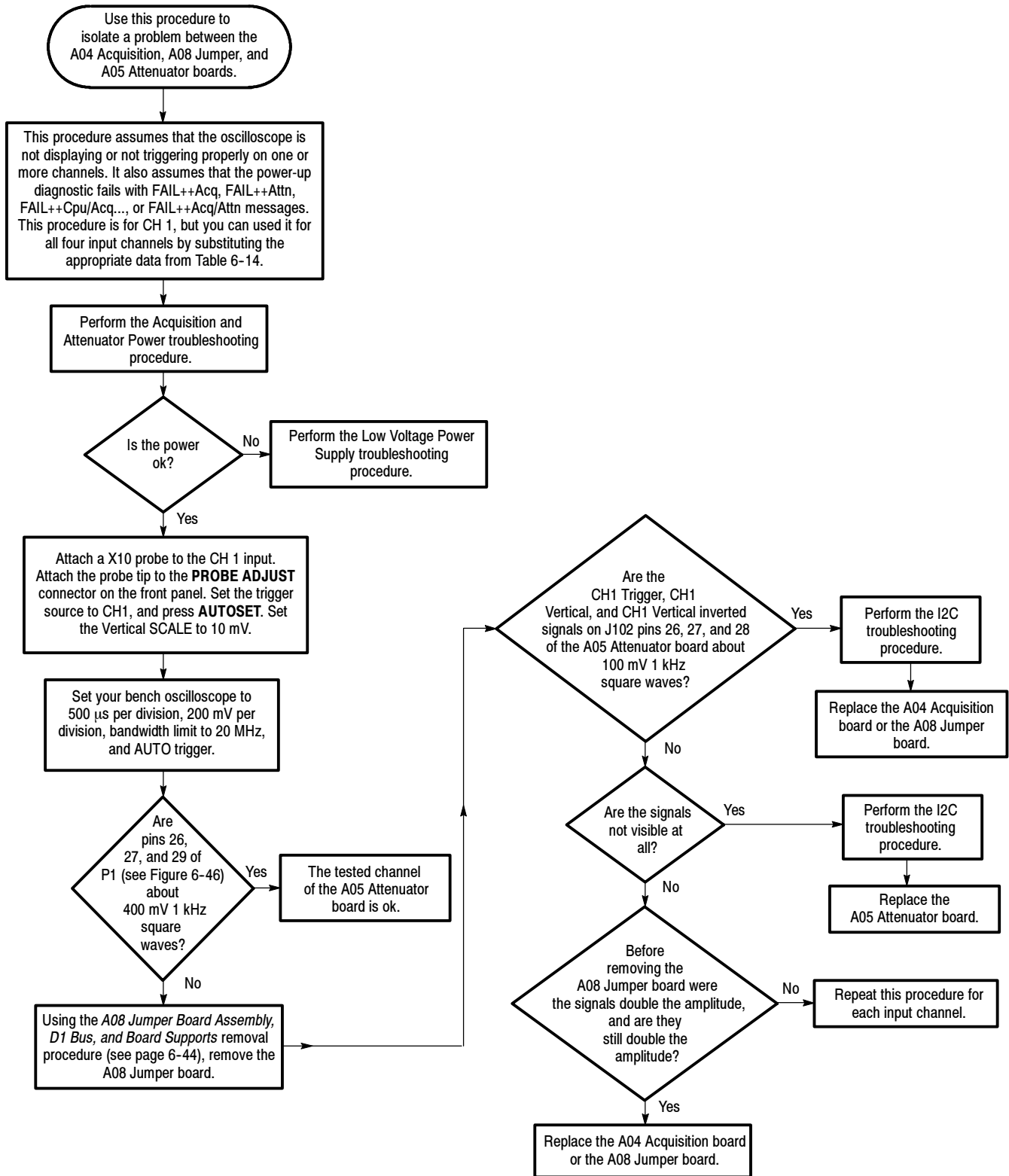

Figure 6-45: Attenuator/Acquisition Troubleshooting Procedure

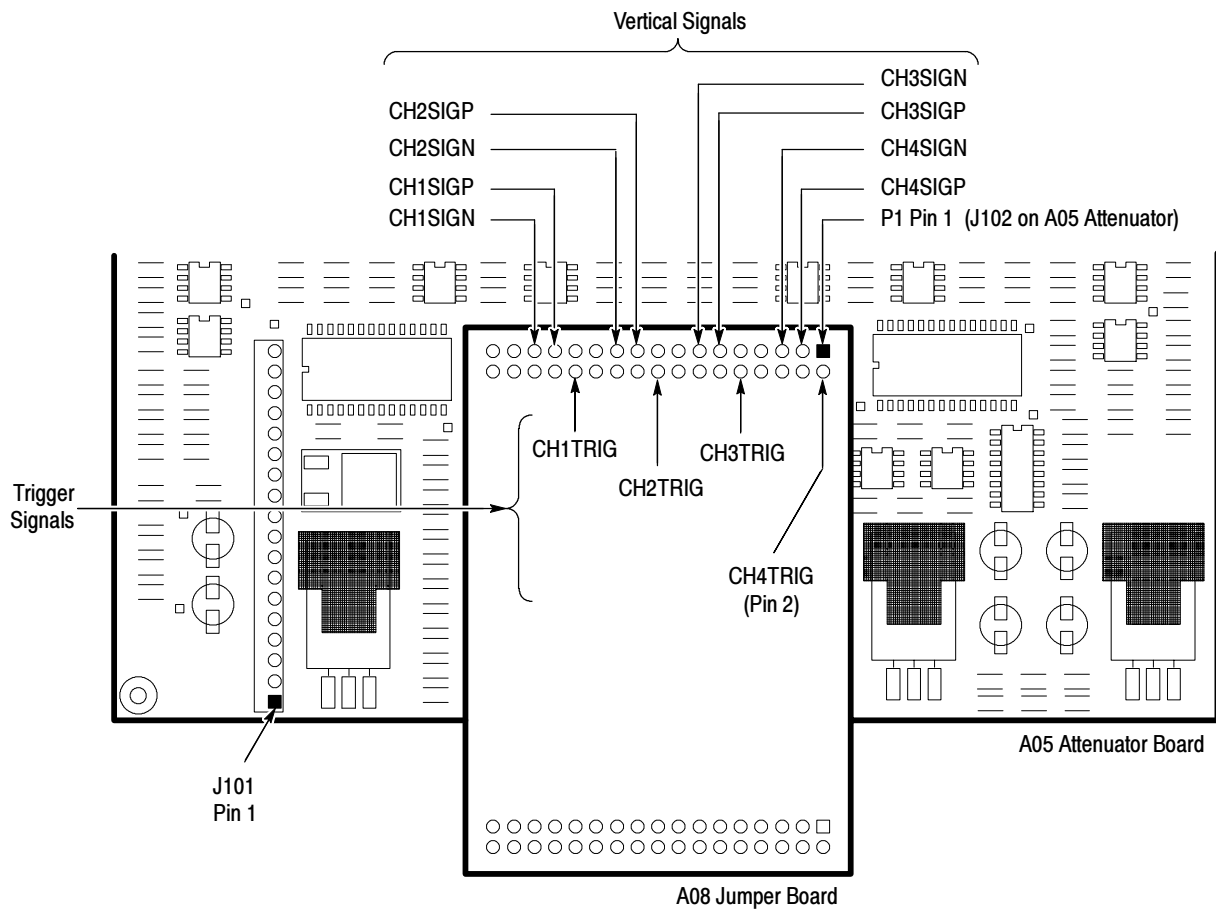

Figure 6-46: A08 Jumper and A05 Attenuator Boards Signal Locations

Table 6-14: Channel and P1 Signal Locations

Channel Number	Trigger P1 Pin Number	Vertical P1 Pin Number	Vertical Inverted P1 Pin Number
1	26	27	29
2	18	19	21
3	10	11	13
4	2	3	5

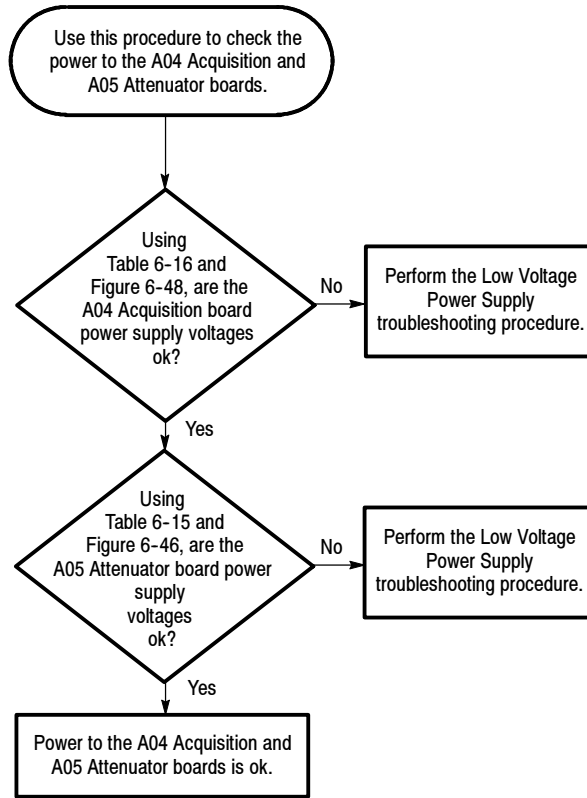

Figure 6-47: Acquisition and Attenuator Power Troubleshooting Procedure

Table 6-15: A05 Attenuator Board Power

J101 Pin	Voltage	High	Low
7	+5.1 V	+5.15 V	+4.9 V
10	+6 V	+6.6 V	+6.0 V
14	-6.4 V	-6.0 V	-6.5 V
16	+15 V	+15.3 V	+14.7 V
17	-15 V	-14.7 V	-15.3 V

Table 6-16: A04 Acquisition Board Power

J7	Voltage	High	Low
9	-15 V	-14.7 V	-15.3 V
12	-6.4 V	-6.0 V	-6.6 V
16	+5 V	+5.15 V	+4.9 V
19	+15 V	+15.3 V	+14.7 V

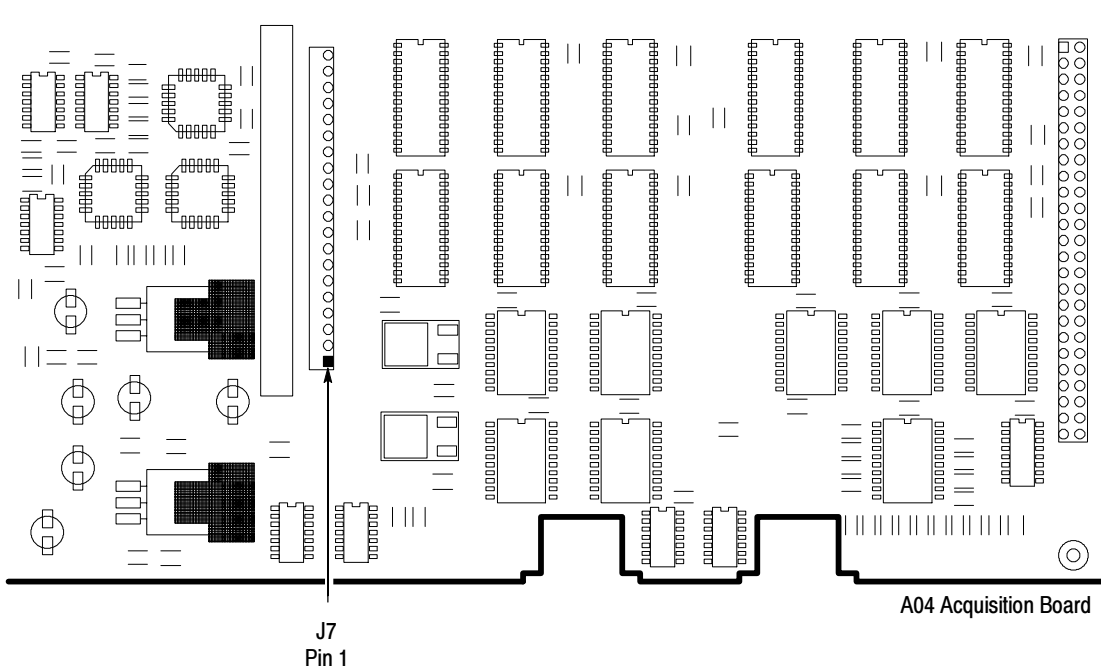

Figure 6-48: A04 Acquisition Board Power Connector

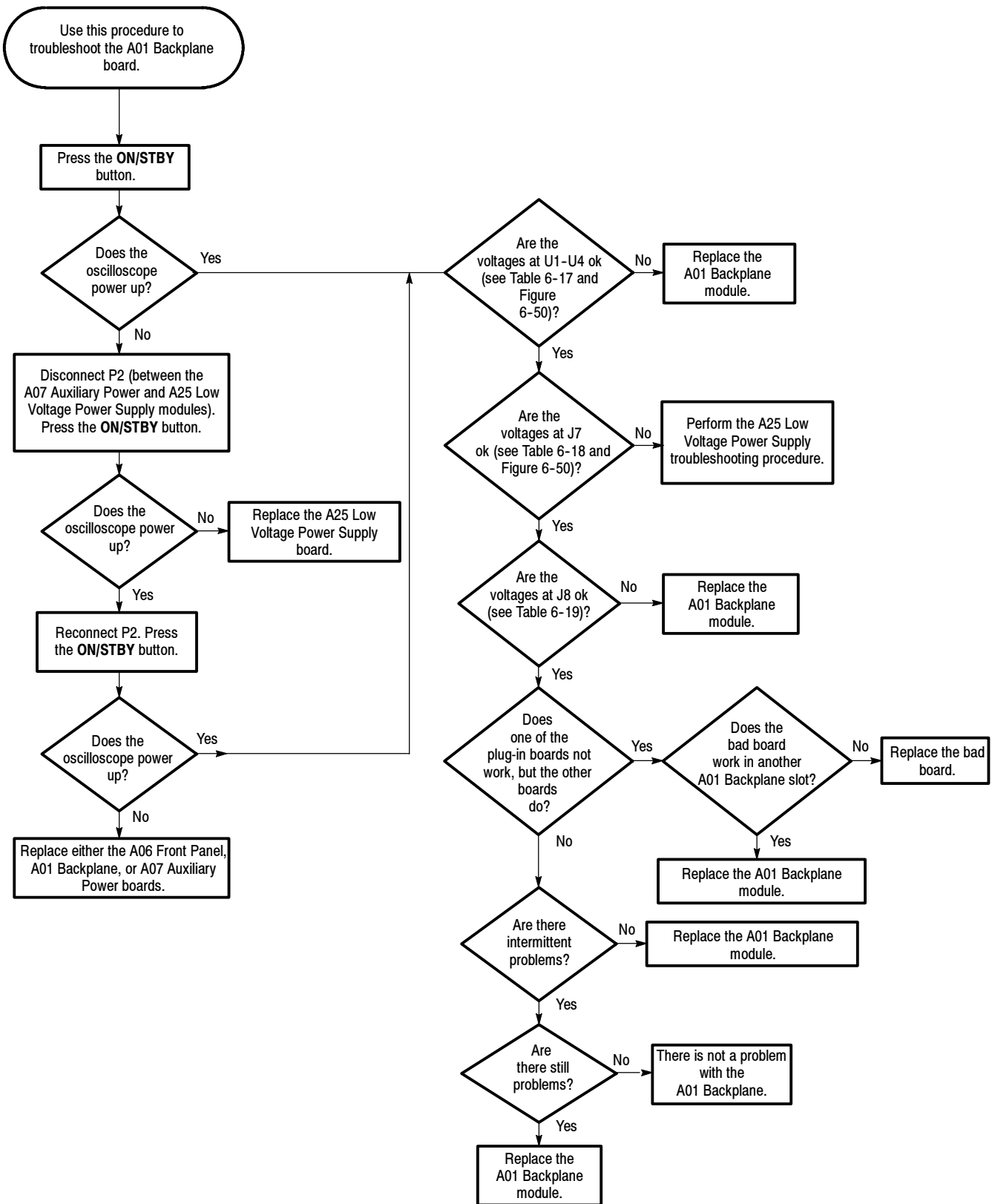

Figure 6-49: Backplane Troubleshooting Procedure

Table 6-17: Regulator Voltages

Regulator	Nominal Voltage	Minimum Voltage	Maximum Voltage
U1 pin 3	-12 V	-11.5 V	-12.5 V
U2 pin 3	+12 V	+11.5 V	+12.5 V
U3 pin 2	+6.3 V	+5.07 V	+6.57 V
U4 pin 3	-5 V	-4.8 V	-5.2 V

Table 6-18: J7 Voltages

Pin	Nominal Voltage	Minimum Voltage	Maximum Voltage
1	-15 V	-14.85 V	-15.15 V
2	-15 V	-14.85 V	-15.15 V
7	-6.4 V	-6.336 V	-6.464 V
8	+15 V	+14.85 V	+15.15 V
9	+15 V	+14.85 V	+15.15 V
18	+5.1 V	+5.151 V	+5.05 V
19	+5.1 V	+5.151 V	+5.05 V

Table 6-19: J8 Front Panel Voltages

Pin	Nominal Voltage	Minimum Voltage	Maximum Voltage
1	+15 V	+14.25 V	+15.75 V
2	+5 V	+5.05 V	+5.15 V
4	-5 V	-5.05 V	-5.2 V
5	-15 V	-14.85 V	-15.15 V

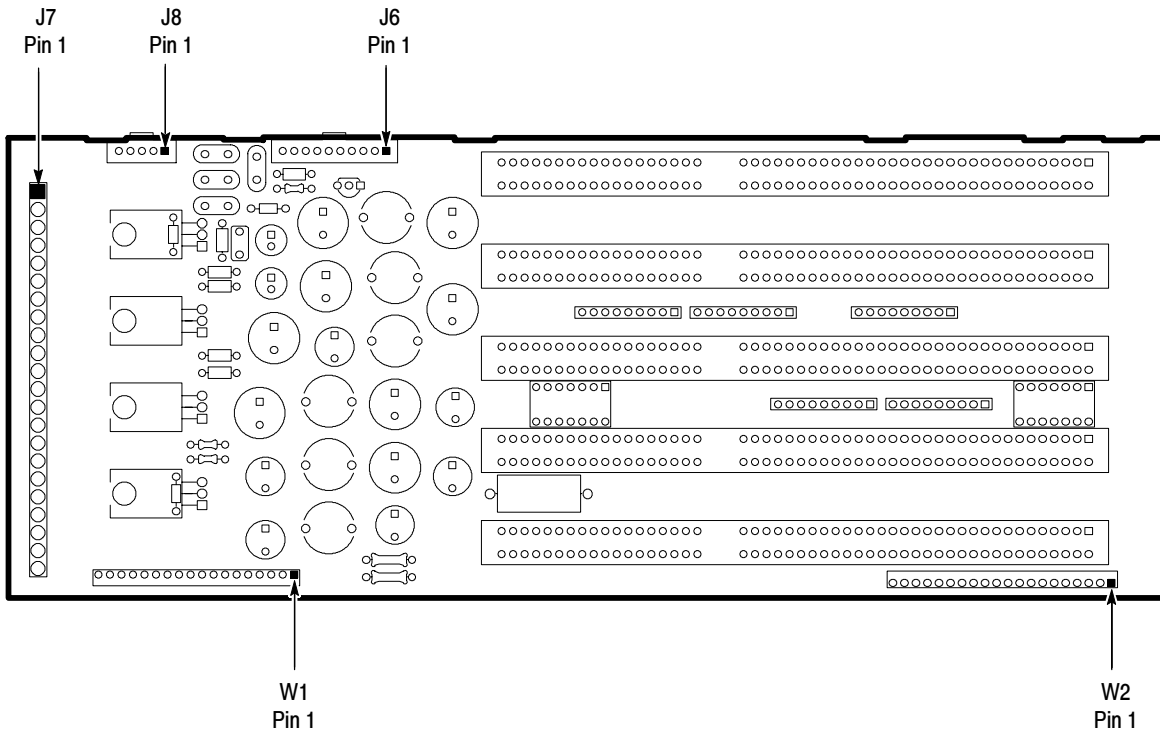

Figure 6-50: A01 Backplane Module

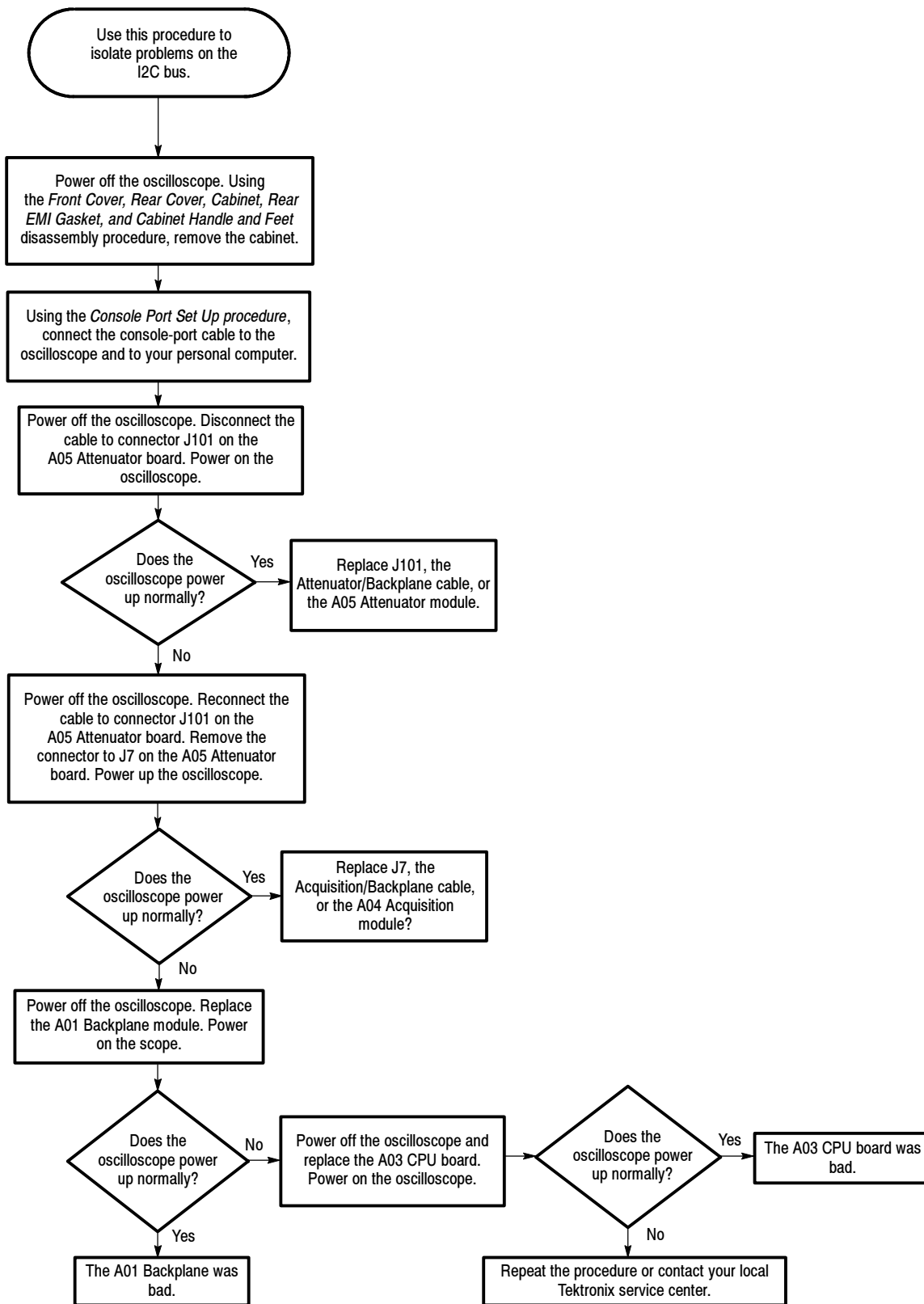

Figure 6-51: I2C Isolation Troubleshooting Procedure

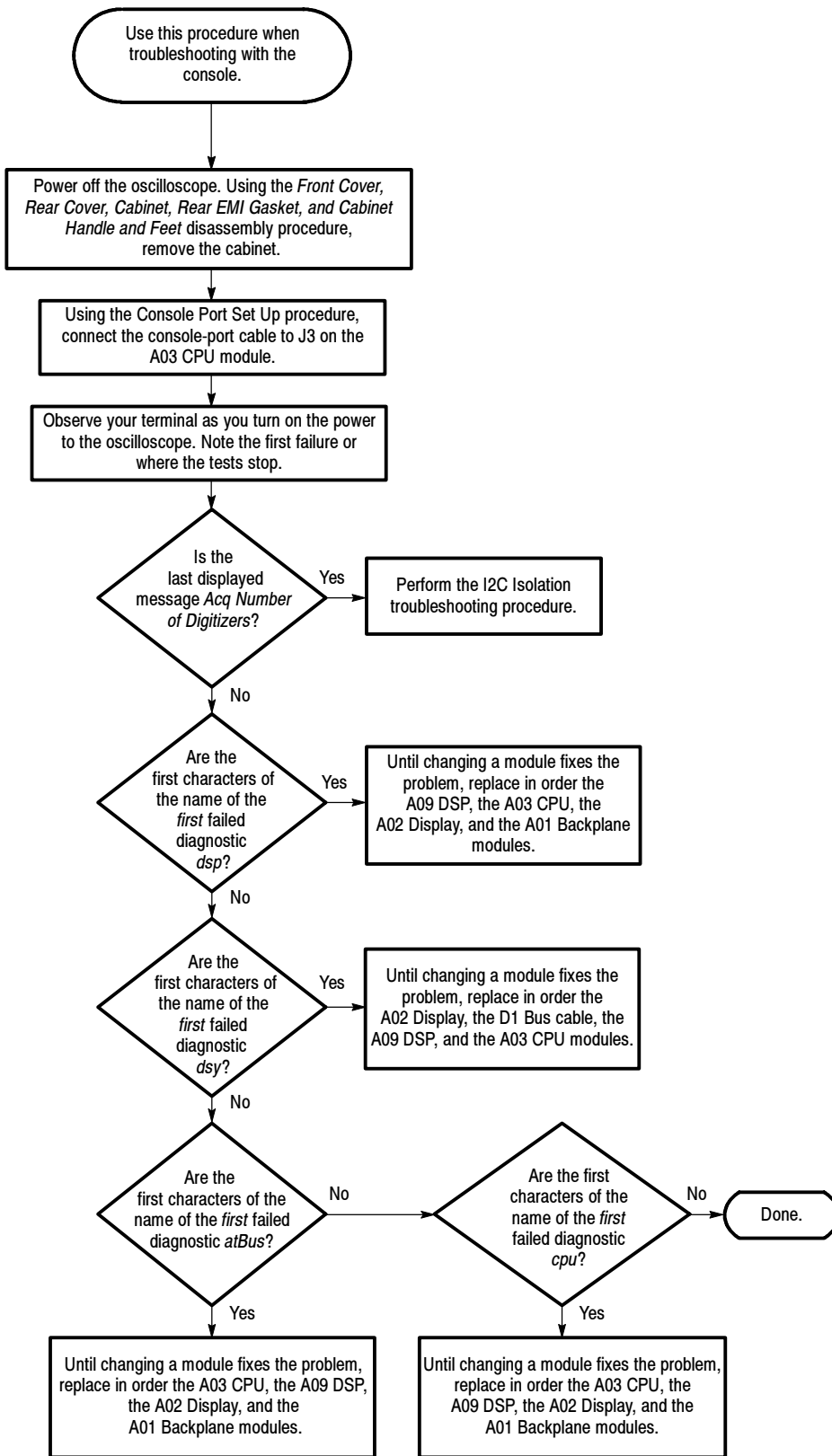

Figure 6- 52: Console Troubleshooting Procedure

Options and Accessories

This chapter describes the various options and accessories that are available for the TDS 420A, TDS 430A, and TDS 460A Digitizing Oscilloscopes.

Options

The following options are available.

**Option 02: Front Cover
and Pouch (TDS 400A
Only)**

See Option XL.

Option 05: Video Trigger

This option provides a video trigger. It lets you trigger on positive or negative sync pulses. It also lets you select interlaced field one, interlaced field two, or both fields noninterlaced. You can define the signal class to be NTSC, PAL, SECAM, or you can customize the class.

**Option 13:
RS-232/Centronics
Hardcopy Interface**

See Option XL.

**Option 1M: 120,000 Point
Record Length**

See Option XL.

**Option 1R: Rackmounted
Digitizing Oscilloscope**

With this option, Tektronix ships the digitizing oscilloscope configured for installation in a 19 inch wide instrument rack.

**Option 2F: Advanced DSP
Math**

See Option XL.

**Option XL: Options 02, 13,
1M, and 2F**

With this option, Tektronix ships a front cover and pouch, RS-232 and a Centronics interface that can be used to obtain hardcopies of the oscilloscope screen, a 120,000 Point Record Length, and advanced DSP math (the oscilloscope can compute and display three advanced math waveforms: integral of a waveform, differential of a waveform, and an FFT (Fast Fourier Transform) of a waveform).

**Option 95: Test Data
Report**

With this option, Tektronix ships a test data report for the oscilloscope.

**Options A1-A5:
International Power Cords**

Besides the standard North American, 110 V, 60 Hz power cord, Tektronix ships any of five alternate power cord configurations (listed in Table 7-1) with the oscilloscope when ordered by the customer.

Table 7-1: International Power Cords

Option	Power Cord
A1	Universal European — 220 V, 50 Hz
A2	UK — 240 V, 50 Hz
A3	Australian — 240 V, 50 Hz
A4	North American — 240 V, 60 Hz
A5	Switzerland — 220 V, 50 Hz

**Option L1: French User
Manual**

With this option, Tektronix ships a French language user manual.

**Option L3: German User
Manual**

With this option, Tektronix ships a German language user manual.

**Option L5: Japanese User
Manual**

With this option, Tektronix ships a Japanese language user manual.

Standard Accessories

Table 7-2 lists the standard accessories that are included with the digitizing oscilloscope:

Table 7-2: Standard Accessories

Accessory	Part Number
User Manual	070-9701-XX
Reference	020-2192-XX
Performance Verification	070-9705-XX
U.S. Power Cord	161-0230-01
Probes (one per channel)	P6138/P6138A 10X Passive (TDS 420A) P6138A 10X Passive (TDS 430A) P6138A 10X Passive (TDS 460A)
	P6138A (single unit)

Optional Accessories

You can also order the optional accessories listed in Table 7-3:

Table 7-3: Optional Accessories

Accessory	Part Number
Front Cover	200-3232-00
Service Manual	070-9703-XX
Printed Programmer Manual	070-9876-XX
Video Clamp	013-0278-00
Current Probe/Calibrator	TCP202
High Voltage Differential Probe	P5205
High Voltage Differential Probe	P5200
Analog Differential Amplifier	ADA400A
Plotter (GPIB and Centronics Standard)	HC100
Plotter (Centronics Standard)	HC200
Oscilloscope Cart	K212
Oscilloscope Camera	C9
Oscilloscope Camera Adapter	016-1154-00
Soft-Sided Carrying Case	016-1158-01
Transit Case	016-1157-00
GPIB Cable (1 meter)	012-0991-01
GPIB Cable (2 meter)	012-0991-00
Printer Pack with Seiko DPU-411 printer and accessory pouch	TDS4F5P
Pouch (includes mounting plate)	016-1159-00
VGA Cable (Required to meet all emissions specifications)	CTL3VGAMM-5 (LCOM part number)

Accessory Probes

Table 7-4 lists compatible probes recommended for use with your digitizing oscilloscope:

Table 7-4: Compatible Probes

Probe Type	Tektronix Model	Description
Passive, high impedance voltage	P6138A	10X, 400 MHz
	P6101B	1X, 15 MHz
Passive, SMD	P6563A	20X, 500 MHz

Table 7-4: Compatible Probes (Cont.)

Probe Type	Tektronix Model	Description
Passive, low impedance Zo	P6156	10X, 3.5 GHz, for 50 Ω inputs (1X, 20X, 100X optional)
Passive, high voltage	P5100 P6015A	100X, 2.5 kV, DC + peak AC 1000X, 20 kV, DC + peak AC
Active, high speed voltage	P6243 P6204	DC to 1 GHz FET, TekProbe powered DC to 1 GHz FET, DC Offset capability (requires Tektronix 1103 TekProbe Power Supply for offset capability)
Active, differential voltage	P6046 P5205	1X/10X, 250 V, DC to 100 MHz 50X/500X, 1300 V, DC to 100 MHz
Current	AM 503S AM 503S Opt. 03 AM 503S Opt. 05 TCP202 P6021 P6022 CT-1/CT-2 CT-4	AC/DC, Uses DC to 50 MHz A6302 Current Probe AC/DC, Uses DC to 15 MHz A6303 Current Probe AC/DC, Uses DC to 100 MHz A6312 Current Probe AC/DC, DC to 50 MHz, TekProbe powered AC, 120 Hz to 60 MHz AC, 935 kHz to 120 MHz Designed for permanent or semi-permanent in-circuit installation CT-1: 25 kHz to 1 GHz, 50 Ω input CT-2: 1.2 kHz to 200 MHz, 50 Ω input Current Transformer for use with AM 503S and P6021. Peak pulse 1 kA, 0.5 Hz to 20 MHz with AM 503S
Logic Word Trigger	P6408	16 channel, one qualifier channel, TTL compatible, +5 V power supply required
Optical (Opto-Electric Converters)	P6701A P6703A P6711 P6713	500 to 950 nm, DC to 850 MHz, 1 V/mW 1100 to 1700 nm, DC to 1 GHz, 1 V/mW 500 to 950 nm, DC to 250 MHz, 5 V/mW 1100 to 1700 nm, DC to 300 MHz, 5 V/mW

Accessory Software

Table 7-5 lists optional accessories that are Tektronix software products recommended for use with your digitizing oscilloscope:

Table 7-5: Accessory Software

Software	Part Number
Wavewriter: AWG and waveform creation	S3FT400
LabWindows for DOS for CVI	LWDOS LWCVI
WaveStar	WSTR31

Warranty Information

The warranty statement for this product is after the title page of this manual.

Service Assurance

Tektronix offers the following services that you can purchase any time during the warranty period of this product:

- *REP* (Repair) Service Assurance provides one year of post-warranty repair support. It is available in one year increments up to two years.
- *CAL* (Calibrate) Service Assurance provides one year of calibration support. It is available in one year increments up to five years.

For further information contact your Tektronix Representative.

Electrical Parts List

The modules that make up this instrument are often a combination of mechanical and electrical subparts. Therefore, all replaceable modules are listed in Chapter 10, *Mechanical Parts List*. Refer to that chapter for part numbers when using this manual.

Diagrams

This chapter contains the block diagram and the interconnection diagram for this oscilloscope. If servicing a TDS 430A, ignore all references to CH 3 and CH 4.

Symbols

Graphic symbols and class designation letters are based on ANSI Standard Y32.2-1975. Abbreviations are based on ANSI Y1.1-1972.

Logic symbology is based on ANSI/IEEE Std 91-1984 in terms of positive logic. Logic symbols depict the logic function performed and can differ from the manufacturer's data.

A tilde (~) preceding a signal name or an asterisk following a signal name indicates that the signal performs its intended function when in the low state.

Other Tektronix, ANSI, and military standards are also used in the preparation of diagrams by Tektronix, Inc.

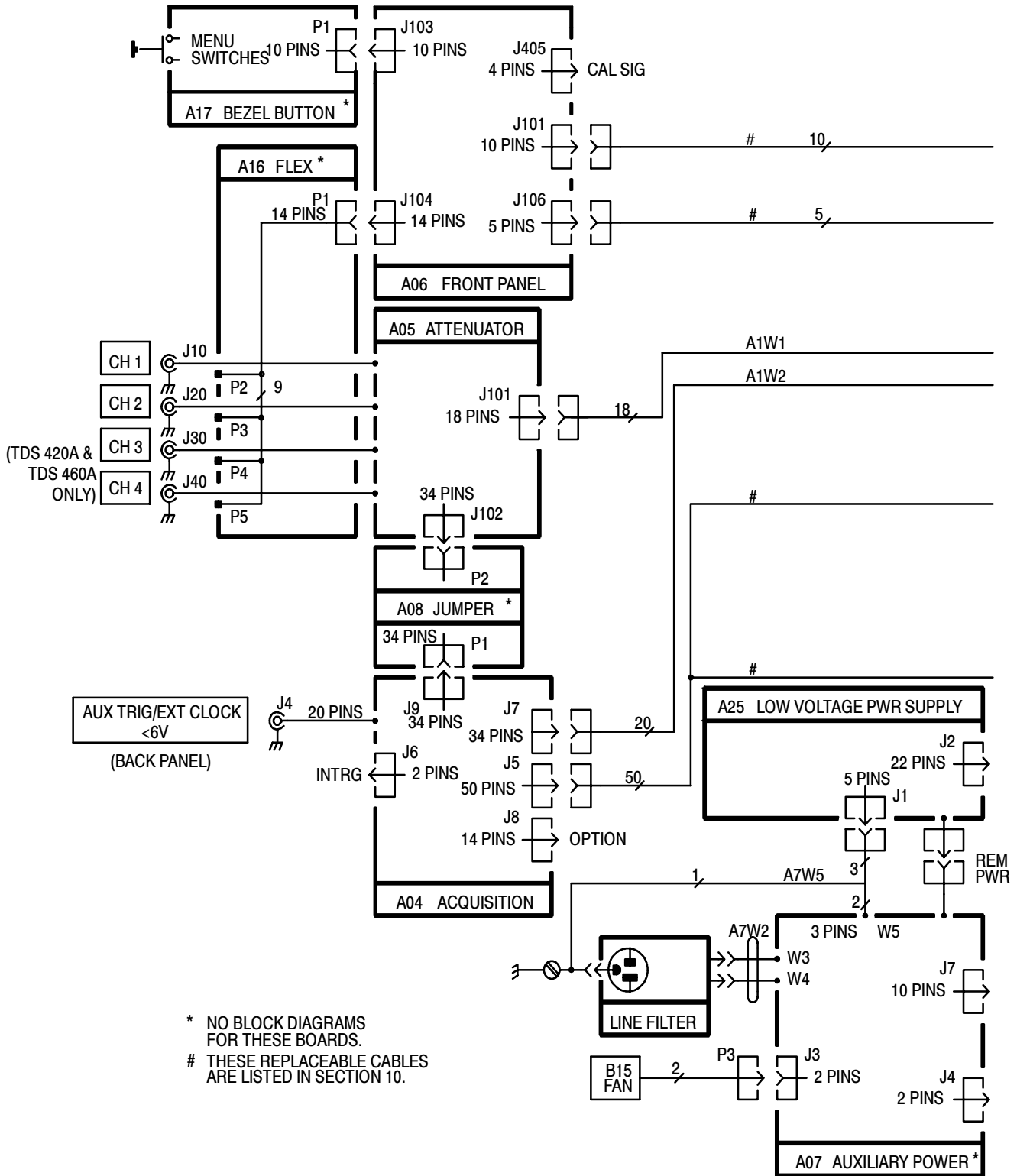

Figure 9- 1: TDS 400A Interconnections, B010100 - B079999

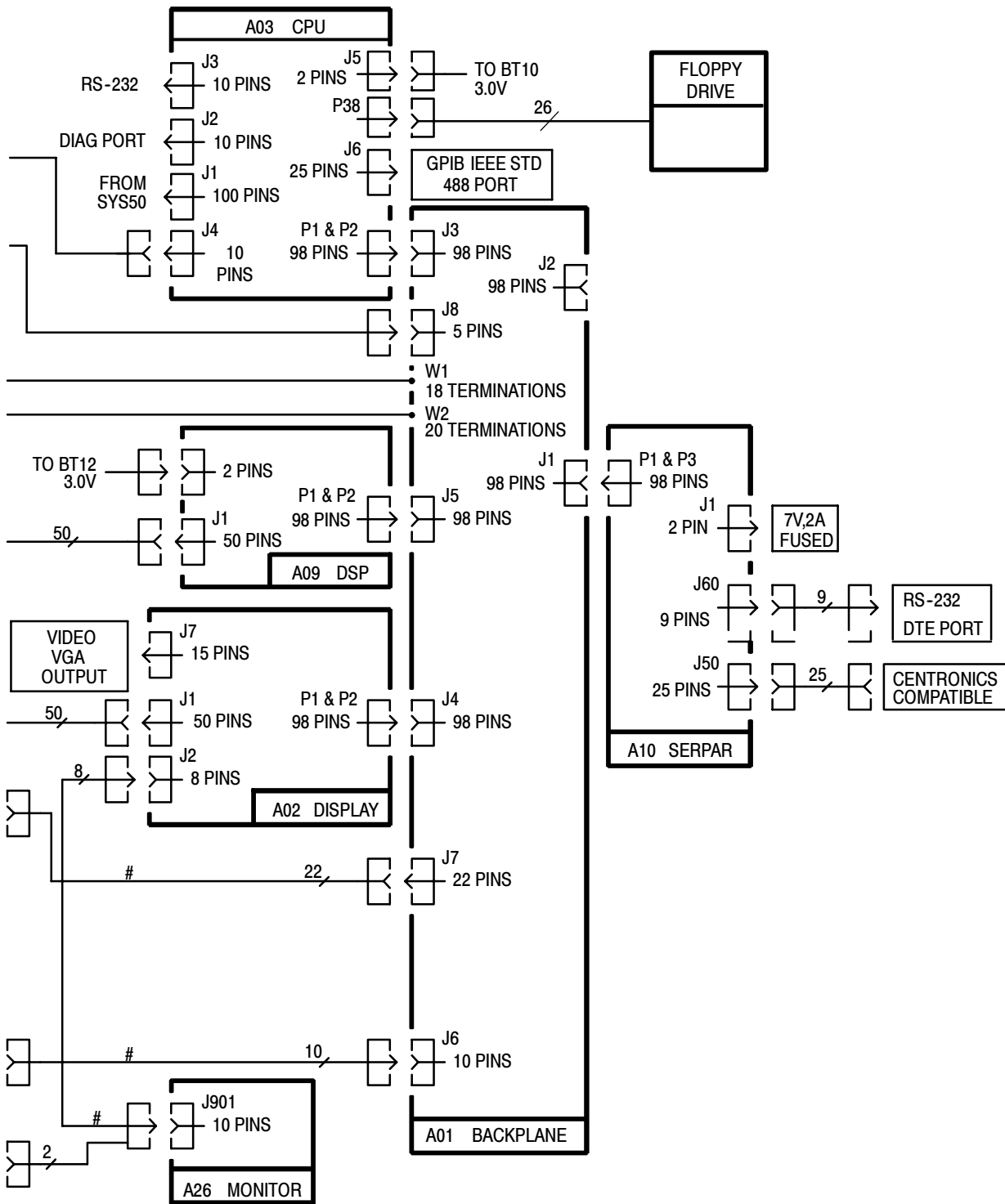

Figure 9-2: TDS 400A Interconnections, B010100 - B079999 (Cont)

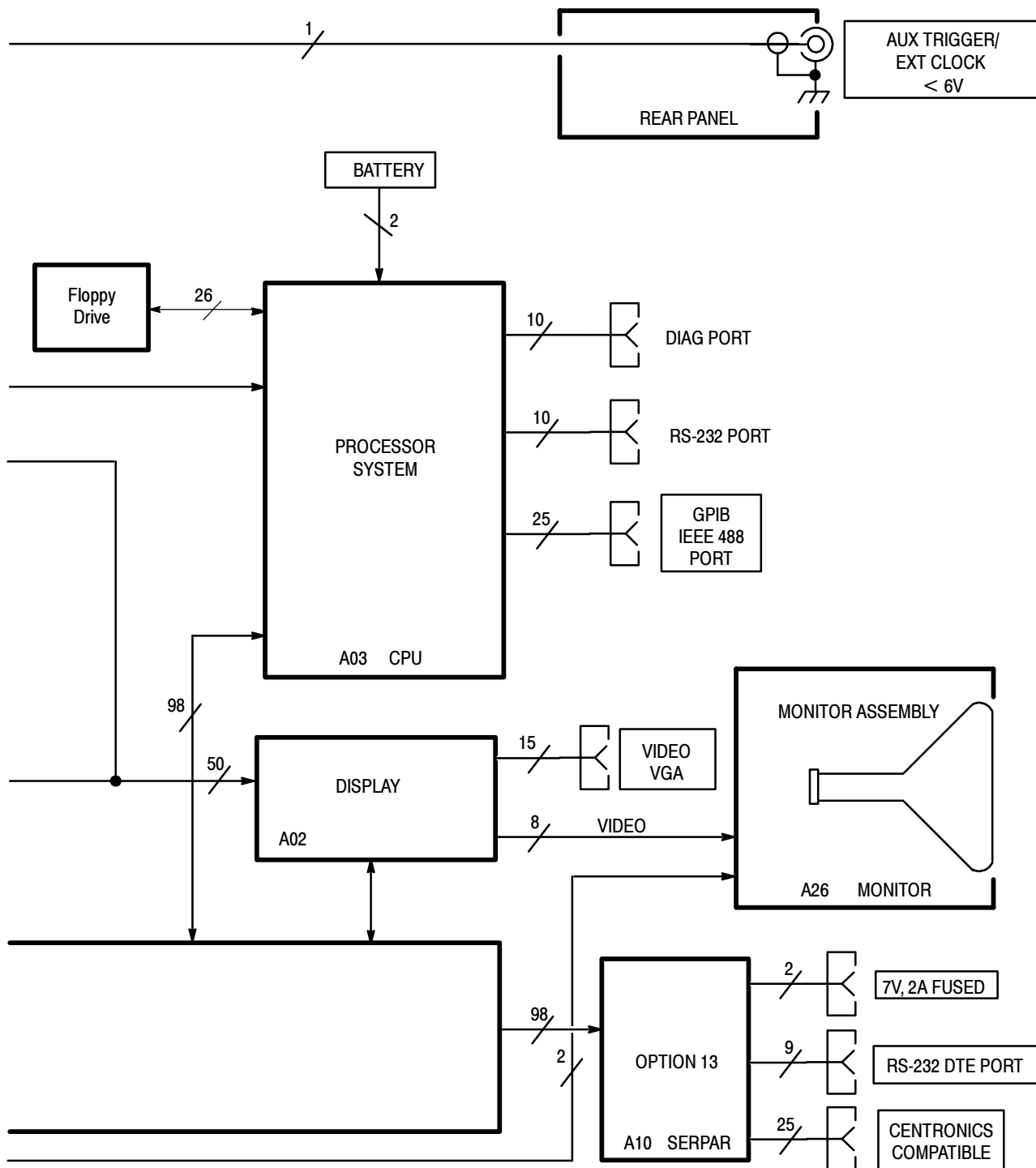

Figure 9-4: TDS 400A Block Diagram, B010100 - B079999 (Cont)

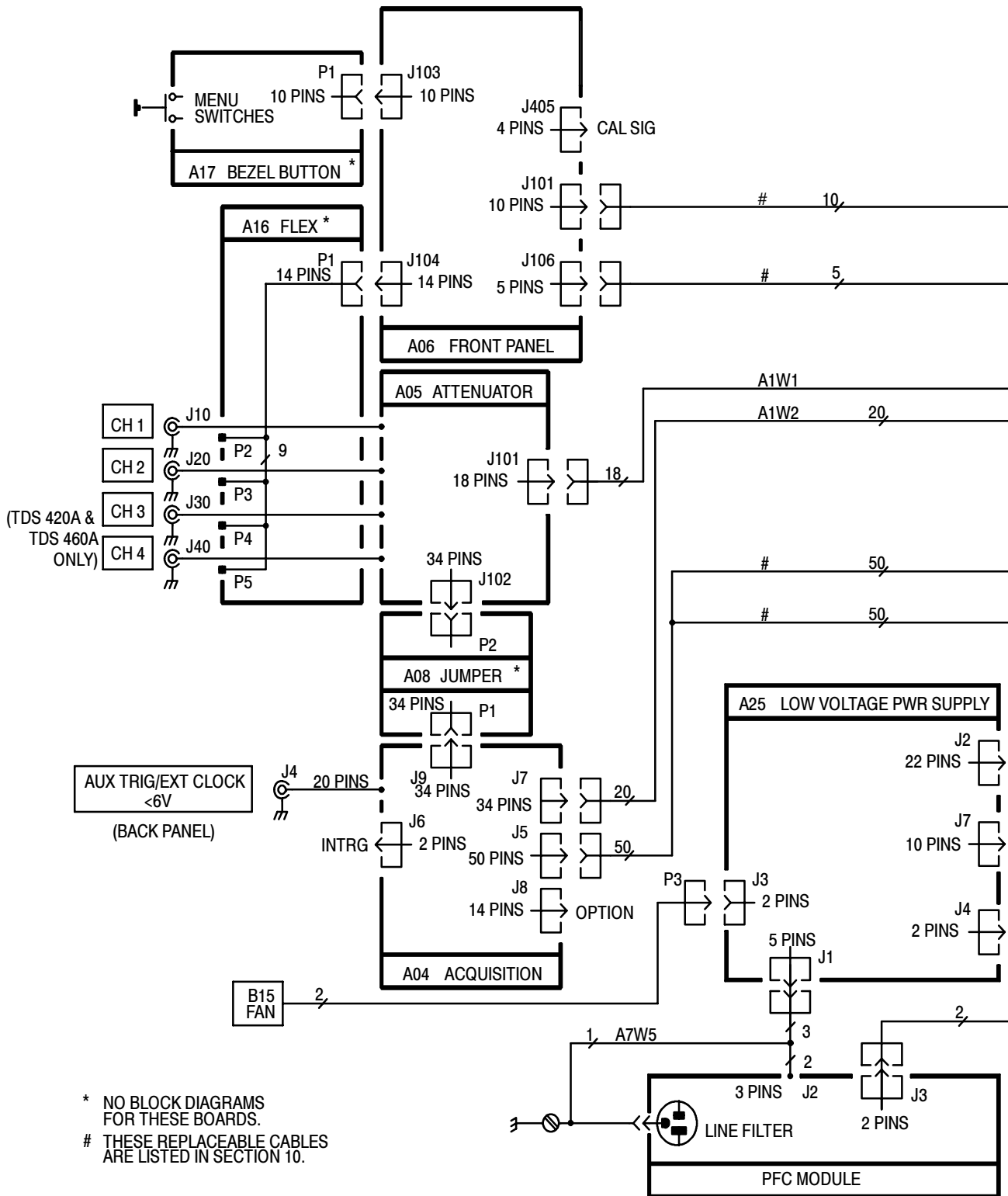

Figure 9-5: TDS 400A Interconnections, B080000 & up

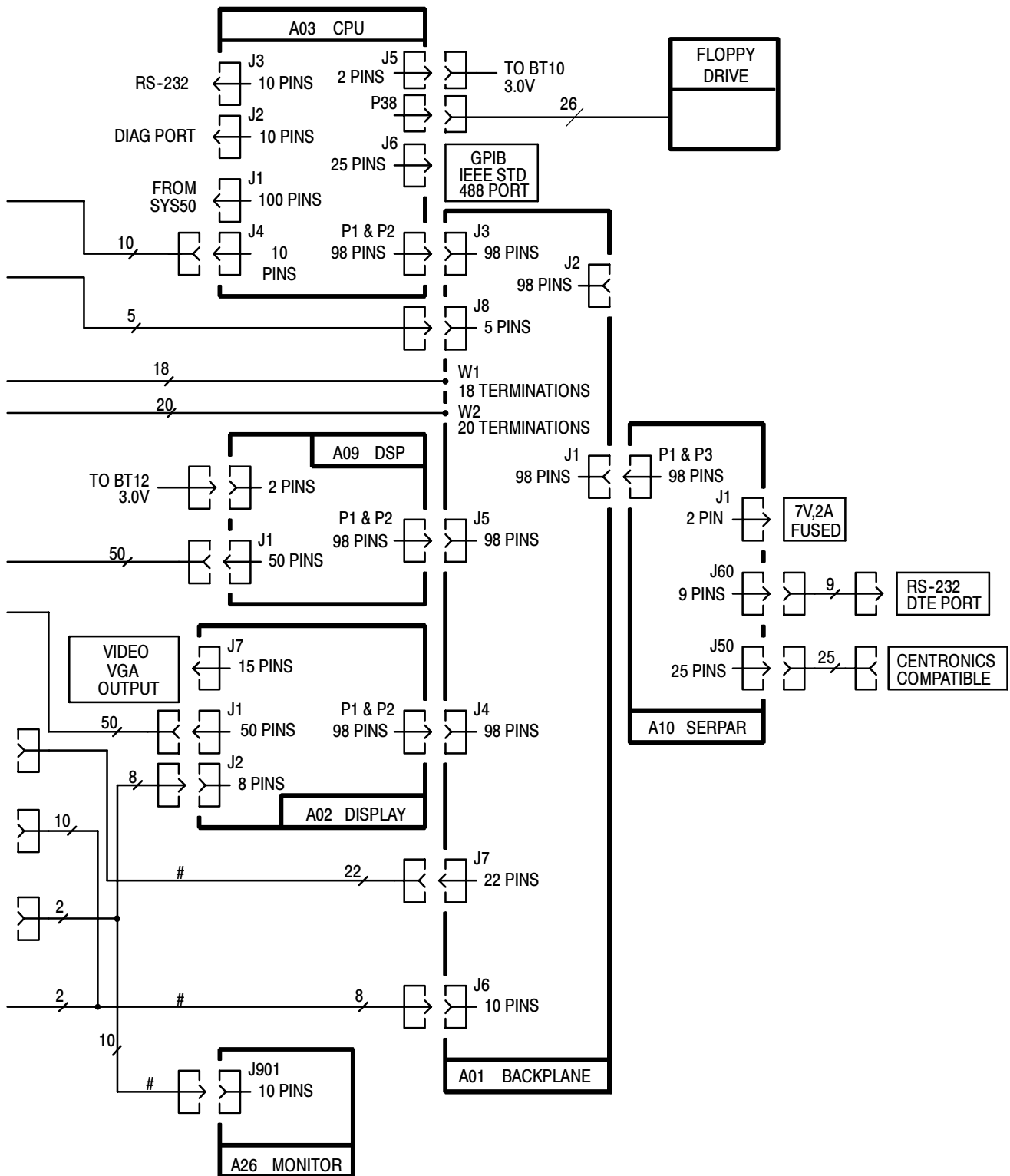

Figure 9-5: TDS 400A Interconnections, B080000 & up (Cont.)

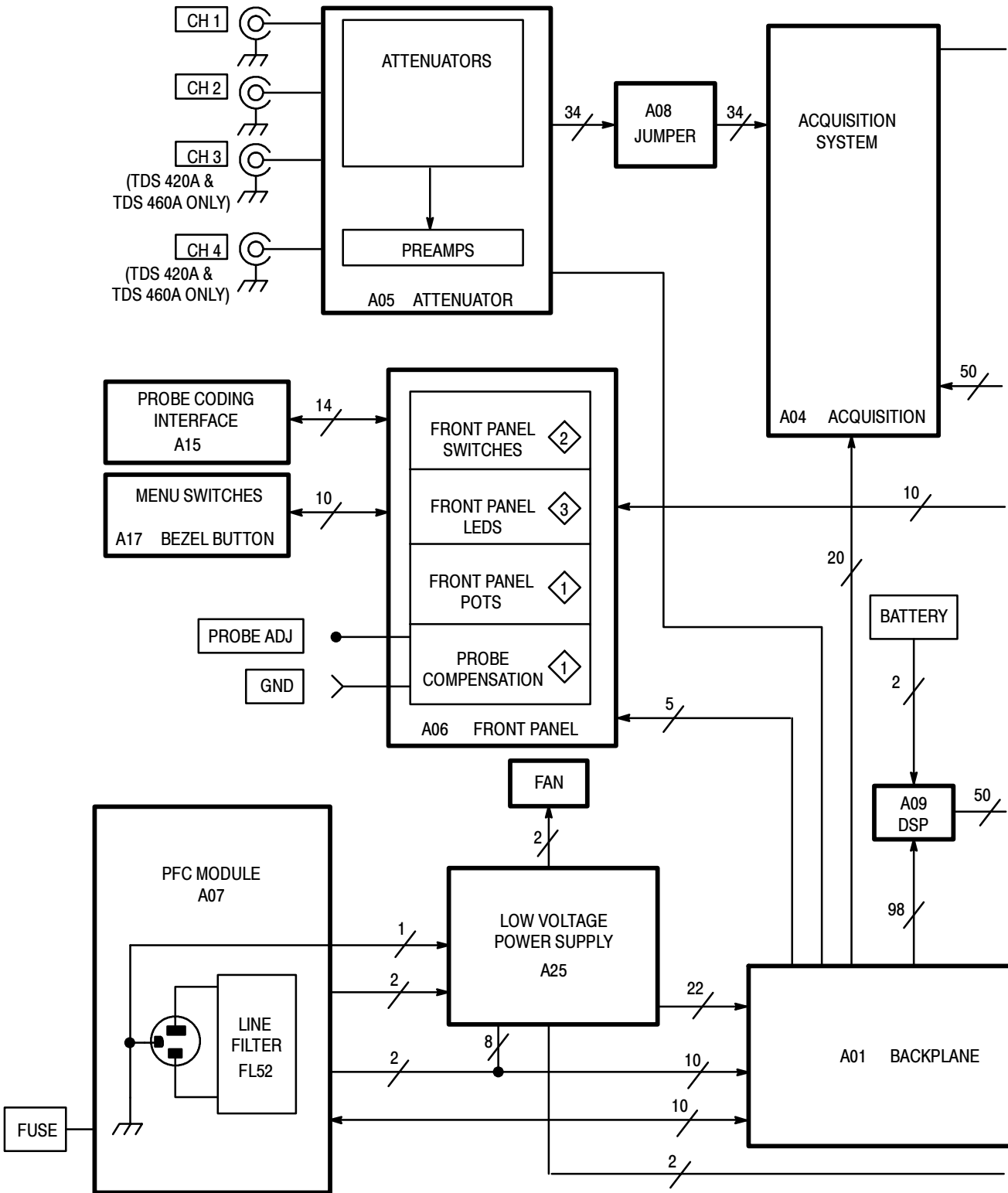

Figure 9- 6: TDS 400A Block Diagram, B080000 & up

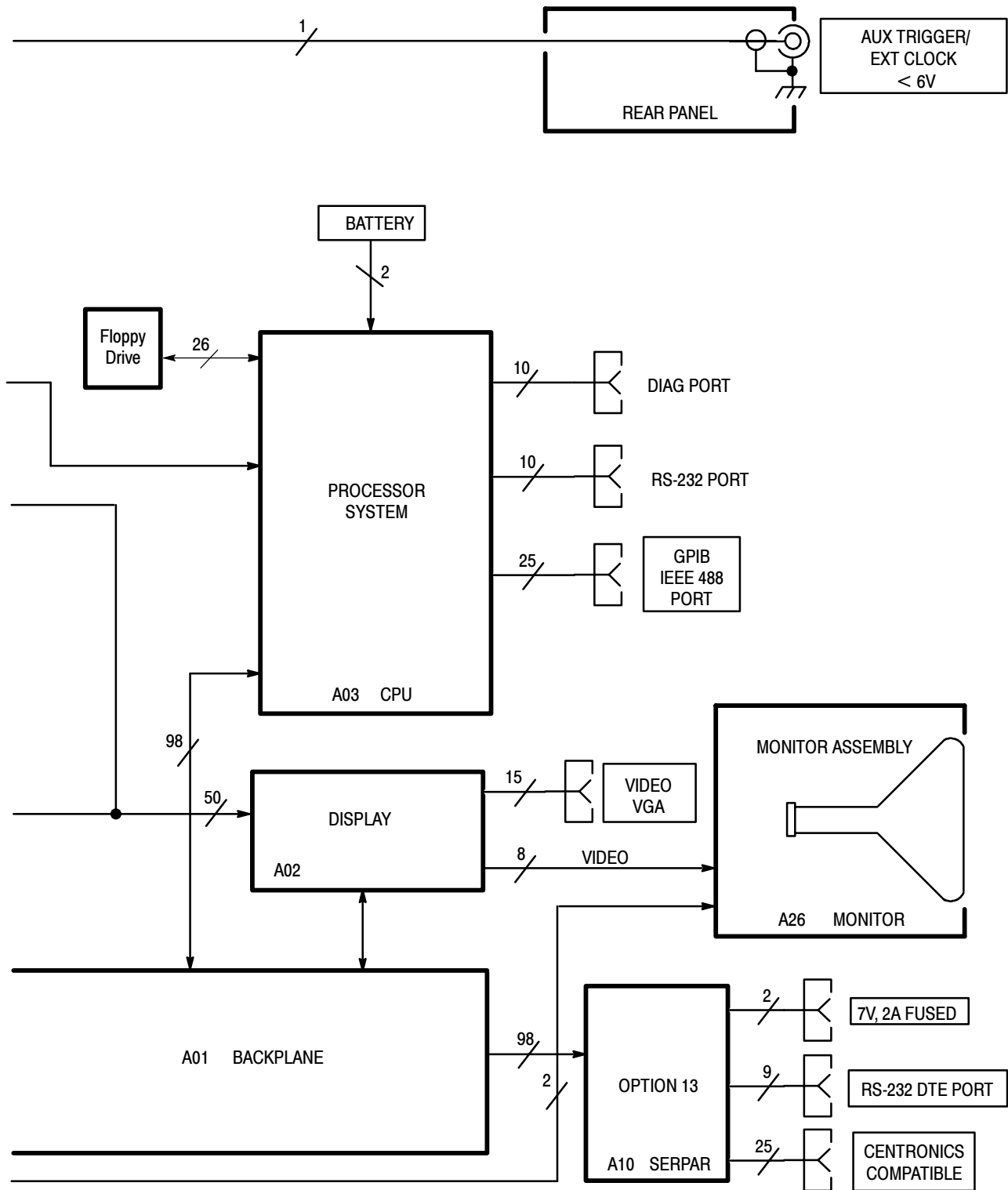

Figure 9-6: TDS 400A Block Diagram, B08000 & up (Cont.)

Replaceable Parts

This section contains a list of the replaceable modules for the <instrument>. Use this list to identify and order replacement parts.

Parts Ordering Information

Replacement parts are available through your local Tektronix field office or representative.

Changes to Tektronix products are sometimes made to accommodate improved components as they become available and to give you the benefit of the latest improvements. Therefore, when ordering parts, it is important to include the following information in your order:

- Part number (see Part Number Revision Level below)
- Instrument type or model number
- Instrument serial number
- Instrument modification number, if applicable

If you order a part that has been replaced with a different or improved part, your local Tektronix field office or representative will contact you concerning any change in part number.

Change information, if any, is located at the rear of this manual.

Part Number Revision Level

Tektronix part numbers contain two digits that show the revision level of the part. For most parts in this manual, you will find the letters XX in place of the revision level number.



When you order parts, Tektronix will provide you with the most current part for your product type, serial number, and modification (if applicable). At the time of your order, Tektronix will determine the part number revision level needed for your product, based on the information you provide.

Module Servicing Modules can be serviced by selecting one of the following three options. Contact your local Tektronix service center or representative for repair assistance.

Module Exchange. In some cases you may exchange your module for a remanufactured module. These modules cost significantly less than new modules and meet the same factory specifications. For more information about the module exchange program, call 1-800-TEK-WIDE, extension 6630.

Module Repair and Return. You may ship your module to us for repair, after which we will return it to you.

New Modules. You may purchase replacement modules in the same way as other replacement parts.

Using the Replaceable Parts List

This section contains a list of the mechanical and/or electrical components that are replaceable for the <instrument>. Use this list to identify and order replacement parts. The following table describes each column in the parts list.

Parts List Column Descriptions

Column	Column Name	Description
1	Figure & Index Number	Items in this section are referenced by figure and index numbers to the exploded view illustrations that follow.
2	Tektronix Part Number	Use this part number when ordering replacement parts from Tektronix.
3 and 4	Serial Number	Column three indicates the serial number at which the part was first effective. Column four indicates the serial number at which the part was discontinued. No entries indicates the part is good for all serial numbers.
5	Qty	This indicates the quantity of parts used.
6	Name & Description	An item name is separated from the description by a colon (:). Because of space limitations, an item name may sometimes appear as incomplete. Use the U.S. Federal Catalog handbook H6-1 for further item name identification.
7	Mfr. Code	This indicates the code of the actual manufacturer of the part.
8	Mfr. Part Number	This indicates the actual manufacturer's or vendor's part number.

Abbreviations Abbreviations conform to American National Standard ANSI Y1.1-1972.

Mfr. Code to Manufacturer Cross Index The table titled Manufacturers Cross Index shows codes, names, and addresses of manufacturers or vendors of components listed in the parts list.

CROSS INDEX - MFR. CODE NUMBER TO MANUFACTURER

Mfr. Code	Manufacturer	Address	City, State, Zip Code
S3109	FELLER	72 VERONICA AVE UNIT 4	SUMMERSET NJ 08873
S3629	SCHURTER AG H C/O PANEL COMPONENTS CORP	2015 SECOND STREET	BERKELEY CA 94170
S4246	JAPAN SERVO CO LTD	7 KANDA MITOSHIRO-CHO CHIYODA-KU	TOKYO JAPAN
TK0435	LEWIS SCREW CO	4300 S RACINE AVE	CHICAGO IL 60609-3320
TK0860	LABEL GRAPHICS	6700 SW BRADBURY CT	PORTLAND OR 97224
TK1163	POLYCAST INC	9898 SW TIGARD ST	TIGARD OR 97223
TK1891	PRESTOLE CORP	34589 GLENDALE ST	LIVONIA MI 48150-1303
TK1908	PLASTIC MOLDED PRODUCTS	4336 SO ADAMS	TACOMA WA 98409
TK1918	SHIN-ETSU POLYMER AMERICA INC	1181 NORTH 4TH ST	SAN JOSE CA 95112
TK1935	ACCRA-FAB INC	11007 NE 37TH CIRCLE	VANCOUVER WA 98682
TK2058	TDK CORPORATION OF AMERICA	2055 GATEWAY PLACE SUITE 200	SAN JOSE CA 95110
TK2432	UNION ELECTRIC	15/F #1, FU-SHING N. ROAD	TAIPEI, TAIWAN ROC
060D9	UNITREK CORPORATION	3000 COLUMBIA HOUSE BLVD, SUITE 1 20	VANCOUVER, WA 98661
0KB01	STAUFFER SUPPLY CO	810 SE SHERMAN	PORTLAND, OR 97214-4657
0KB05	NORTH STAR NAMEPLATE INC	LABEL PRODUCTS 5750 NE MOORE COURT	HILLSBORO, OR 97124-6474
26003	MARTEK POWER MDI	4115 SPENCER STREET	TORRANCE, CA 90503-2489
TK1163	POLYCAST INC	14140 SW 72ND AVE SUITE 100	TIGARD, OR 97224
TK2478	GRIMES COMPANY	115 S AROVISTA CIRCLE	BREA CA 92631
0DWW6	MICRO POWER ELECTRONICS	7973 SW CIRRRUS DRIVE BLDG. #22	BEAVERTON OR 97005
0JR05	TRIQUEST CORP	3000 LEWIS AND CLARK HWY	VANCOUVER WA 98661-2999
00779	AMP INC	2800 FULLING MILL PO BOX 3608	HARRISBURG PA 17105
07416	NELSON NAME PLATE CO	3191 CASITAS	LOS ANGELES CA 90039-2410
1JJ96	KAM ELECTRIC CO	11866 SLATER AVE NE	KIRKLAND WA 98034
18565	CHOMERICS INC	77 DRAGON COURT	WOBURN MA 01801-1039
2K262	BOYD CORP	6136 NE 87TH AVE PO BOX 20038	PORTLAND OR 97220
22670	G M NAMEPLATE INC	2040 15TH AVE WEST	SEATTLE WA 98119-2728
24931	SPECIALTY CONNECTOR CO INC	2100 EARLYWOOD DR PO BOX 547	FRANKLIN IN 46131
30817	INSTRUMENT SPECIALTIES CO INC	EXIT 53 RT 80 BOX A	DELAWARE WATER GAP PA 18327
34416	PARSONS MFG CORP	1055 OBRIAN DR	MENLO PARK CA 94025-1408

CROSS INDEX - MFR. CODE NUMBER TO MANUFACTURER

Mfr. Code	Manufacturer	Address	City, State, Zip Code
61857	SAN-0 INDUSTRIAL CORP	85 ORVILLE DR PO BOX 511	BOHEMIA LONG ISLAND NY 11716-2501
70903	COOPER BELDEN ELECTRONICS WIRE AND CABLE SUB OF COOPER INDUSTRIES INC		
80009	TEKTRONIX INC	14150 SW KARL BRAUN DR PO BOX 500	BEAVERTON OR 97077-0001
50356	TEAC AMERICA INC	7733 TELEGRAPH RD PO BOX 750	MONTEBELLO, CA 90640-6537
50463	POWER SYSTEMS INC.	45 GRIFIN ROAD	SOUTH LINFIELD, CT 06002
060D9	TENSOLITE COMPANY	PRECISION HARNESS AND ASSEMBLY 3000 COLUMBIA HOUSE BLVD #120	VANCOUVER, WA 98661
0KB01	STAUFFER SUPPLY CO	810 SE SHERMAN	PORTLAND, OR 97214-4657
TK0588	UNIVERSAL PRECISION PRODUCT	1775 NW CORNELIUS PASS RD	HILLSBORO, OR 97124

Fig. & Index No.	Tektronix Part No.	Serial No.		Qty	Name & Description	Mfr. Code	Mfr. Part No.
		Effective	Dscont				
10-1-1	390-1109-02			1	CABINET,SCOPE:ALUMINUM,TEK BLUE	80009	390110902
-2	367-0356-01			1	HANDLE,CARRYING	80009	367035601
-3	212-0144-00			2	SCREW,TPG,TF:8-16 X 0.562 L,PLASTITE	0KB01	ORDER BY DESC
-4	348-0659-00			2	FOOT,CABINET:BLACK POLYURETHANE	0JR05	ORDER BY DESC
-5	348-0764-03			1	SHLD GSKT,ELEK:0.125 X 0.188,WIRE MESH,37 L	18565	ORDER BY DESC
-6	334-8176-01			1	MARKER,IDENT:MKD REAR	07416	ORDER BY DESC
-7	334-8561-00			1	MARKER,IDENT:OPTIONS	80009	334856100
-8	161-0230-01			1	CABLE ASSY,PWR,;3,18 AWG,92 L,SVT,TAN (STANDARD ACCESSORY)	TK2432	ORDER BY DESC
-9	343-1213-00	B079999		1	CLAMP,PWR CORD:POLYIMIDE (STANDARD ACCESSORY)	TK1163	ORDER BY DESC
-10	200-2264-00			1	CAP,FUSEHOLDER:3AG FUSES (AMERICAN)	S3629	FEK 031 1666
	200-2265-00			1	CAP,FUSEHOLDER:5 X 20MM FUSES (EUROPEAN)	S3629	FEK 031.1663
-11	159-0014-00			1	FUSE,CARTRIDGE:3AG,5A,250V,0.8SEC (AMERICAN)	61857	SS2-5A
	159-0255-00			1	FUSE,CARTRIDGE:FAST BLOW,4A,125V (EUROPEAN)	61857	EQ4A
-12	211-0691-00			4	SCREW,MACHINE:6-32 X 0.625,PNH,STL	0KB01	ORDER BY DESC
-13	200-3991-02			1	COVER,REAR:HARD,POLYCARBONATE,LEXAN	80009	200399101
-14	211-0730-00			1	SCR,ASSEM WSHR:6-32 X 0.375,PNH,STL CD PL	0KB01	ORDER BY DESC
-15	211-0840-00			1	SCREW,MACHINE:M2.6 X 0.45MM PITCH X 4.0 MM	0KB01	.26C4MXP
-16	259-0085-00			1	FLEX CIRCUIT:PROBE CODE	80009	259008500
-17	348-1258-00			4	SHLD,GASKET,ELE:2 LAYER,0.094 X 0.188 X 8.750	80009	348125800
-18	672-1470-00			1	CIRCUIT BD ASSY:FRONT PANEL ASSY (TDS430A ONLY)	80009	672147000
	672-1436-00			1	CIRCUIT BD ASSY:FRONT PANEL ASSY (TDS420A ONLY)	80009	672143600
	672-1532-00			1	CIRCUIT BD ASSY:FRONT PANEL ASSY (TDS460A ONLY)	80009	672153200
-19	384-1689-01			6	SHAFT EXTENDER:ACETAL	80009	384168901
-20	366-2113-00			3	KNOB:MEDIUM,DETENTED	TK1163	ORDER BY DESC
-21	366-2111-00			3	KNOB:SMALL,FLUTED	TK1163	ORDER BY DESC
-22	200-3232-01			1	COVER,FRONT:ASB (OPTIONAL ACCESSORY)	TK1908	ORDER BY DESC
-23	354-0709-00			1	RING,TRIM:LEXAN 940 (TDS420A/460A ONLY)	80009	354070900
	354-0736-00			1	TRIM,DECORATIVE:FRONT (TDS430A ONLY)	80009	354073600
-24	366-2164-00			14	PUSH BUTTON:SMOKE TAN	80009	366216400
-25	334-8820-00			1	MARKER,IDENT:BEZEL (TDS460A ONLY)	80009	334882000
	334-8821-00			1	MARKER,IDENT:BEZEL (TDS420A ONLY)	80009	334882100
	334-9232-00			1	MARKER,IDENT:BEZEL (TDS430A ONLY)	80009	334923200

Fig. & Index No.	Tektronix Part No.	Serial No.		Qty	Name & Description	Mfr. Code	Mfr. Part No.
		Effective	Dscont				
10-1-26	119-5677-01			1	DISK DRIVE:FLOPPY,3.5 INCH,1.44MB	50356	FD-04HF-2300
-27	200-4219-00			1	COVER:DISK DRIVE,3.5 INCH	80009	200421900
-28	131-5965-00			2	CONTACT,ELEC:ESD PROTECTION,0.005 ST STL	80009	131596500
-29	260-2539-00			1	SWITCH SET:BEZEL	TK1918	260253900
-30	259-0086-00			1	FLEX CIRCUIT:BEZEL BUTTON	07416	ORDER BY DESC
-31	105-1081-00			1	BRKT,ADAPTER:FLOPPY DISK DRIVE	TK1163	105108100
	211-0866-01			1	SCREW,PHIL, M2.5 x 10, PNH, BRZN	0KB01	211-0866-01

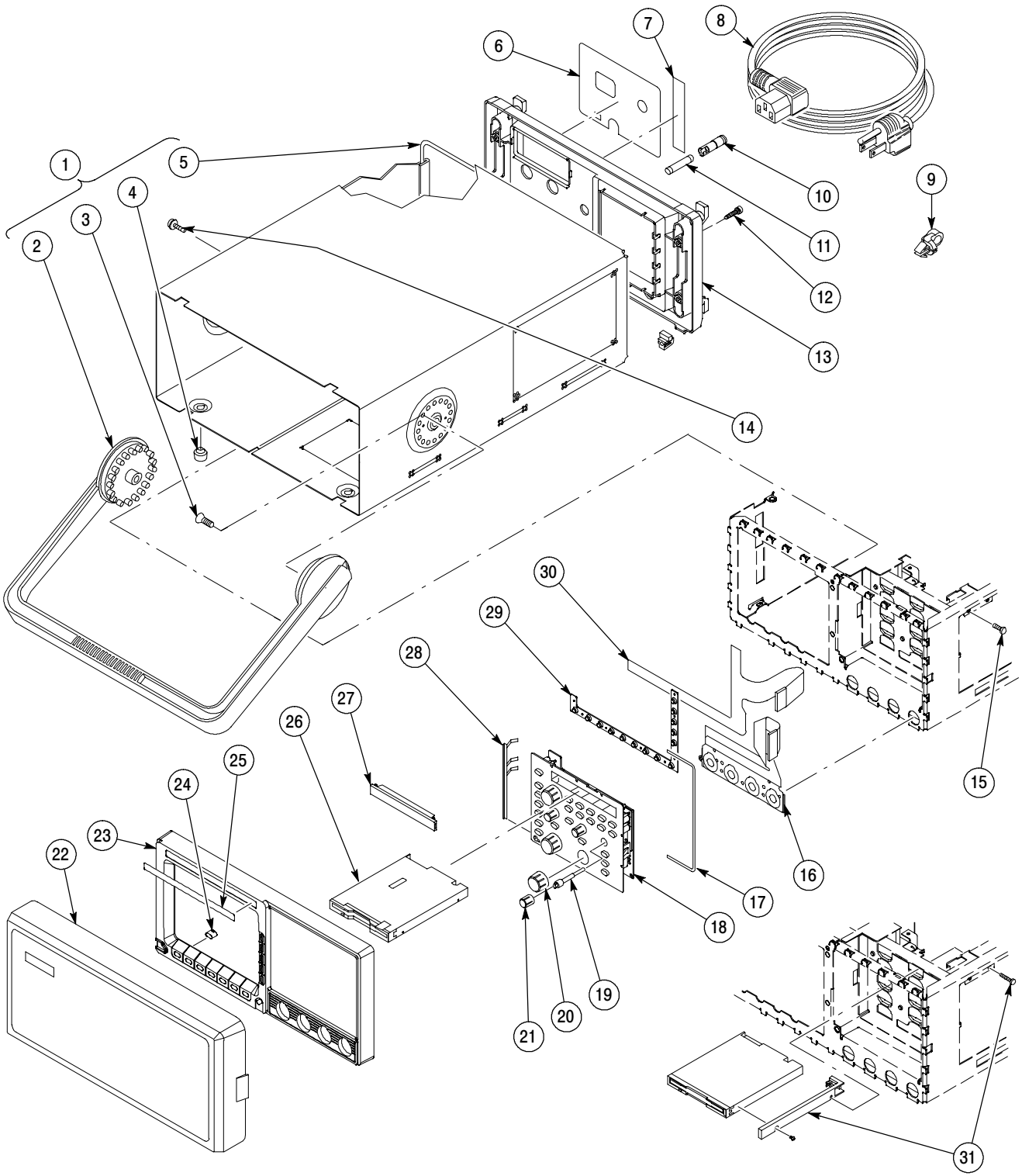

Figure 10-1: External and front panel modules

Fig. & Index No.	Tektronix Part No.	Serial No. Effective Dscnt	Qty	Name & Description	Mfr. Code	Mfr. Part No.
B0101000 - B079999						
10-2-1	426-2436-01		1	FRAME,CRT FLTR:POLYCARBONATE	TK1163	ORDER BY DESC
-2	348-1291-00		2	SHLD,GSKT ELEK:CLIP-ON EM GASKET	30817	9760-5090-20
-3	213-0882-00		37	SCREW,TPG,TR:6-32 X 0.437 TAPTITE,PNH,STL	0KB01	ORDER BY DESC
-4	640-0079-02		1	DISPLAY MODULE:7 INCH, MONOCHROME P31	80009	640007902
-5	426-2426-00		1	FRAME,FAN MTG:POLYCARBONATE	80009	426242600
-6	671-1682-00		1	CIRCUIT BD ASSY:AUXILIARY POWER	80009	671168200
-7	119-1770-00		1	FAN ASSEMBLY:12VDC,1.72W,35CFM W/CONN	S4246	CUDC12D4
-8	119-5557-02		1	POWER SUPPLY:100VAC AT 440 HZ	50463	PSI-135X-38 69
-9	386-6159-00		1	SUPPORT,CKT BD:BACK PLANE & PWR SPLY	80009	386615900
-10	334-3003-00		1	MARKER,IDENT:DANGER POWER LINE	TK0860	ORDER BY DESC
-11	119-5028-00		1	FILTER,RF:4A,250V,48 TO 440HZ	80009	119502800
-12	131-0955-00		1	CONN,RF JACK:BNC,50 OHM,FEMALE,STR	00779	87-3334-017
-13	407-4032-00		2	BRACKET,CKT BD:	80009	407403200
-14	211-0722-00		4	SCREW,MACHINE:6-32 X 0.25,PNH,STL	0KB01	ORDER BY DESC
-15	671-3268-01		1	CIRCUIT BD ASSY:CPU	80009	671326801
-16	671-3902-00		1	CIRCUIT BD ASSY:DISPLAY	80009	671390200
-17	671-3588-00		1	CIRCUIT BD ASSY:DSP (STANDARD)	80009	671358800
	671-3284-00		1	CIRCUIT BD ASSY:DSP (OPTION 1M)	80009	671328400
-18	386-6158-00		3	SUPPORT,CKT BD:MAT MATERIAL	80009	386615800
-19	146-0056-02		2	BATTERY:3V,1200MAH,2/3A LITHIUM BATTERY	0DWW6	ORDER BY DESC
-20	671-3597-01		1	CIRCUIT BD ASSY:ACQUISITION (TDS420A ONLY)	80009	671359701
	671-1685-12		1	CIRCUIT BD ASSY:ACQUISITION (TDS460A ONLY)	80009	671168512
	671-3980-00		1	CIRCUIT BD ASSY:ACQUISITION (TDS430A ONLY)	80009	671398000
-21	344-0116-00		2	RTNR,CAPACITOR:0.625 DIA,STEEL	TK1891	E50003-007
-22	671-1683-00		1	CIRCUIT BD ASSY:JUMPER	80009	671168300
-23	671-3595-01		1	CIRCUIT BD ASSY:ATTENUATOR (TDS420A ONLY)	80009	671359501
	671-1686-07		1	CIRCUIT BD ASSY:ATTENUATOR (TDS460A ONLY)	80009	671168607
	671-3979-00		1	CIRCUIT BD ASSY:ATTENUATOR (TDS430A ONLY)	80009	671397900
-24	337-3713-01		1	SHIELD,ELEC:ATTENUATOR	TK1935	337371301
-25	671-1676-03		1	CIRCUIT BD ASSY:BACKPLANE	80009	671167605
-26	200-3660-00		1	COVER,AUTO CAL:POLYCARBONATE	TK1163	ORDER BY DESC
-27	441-2072-01		1	CHASSIS ASSY:ALUMINUM	80009	441207200

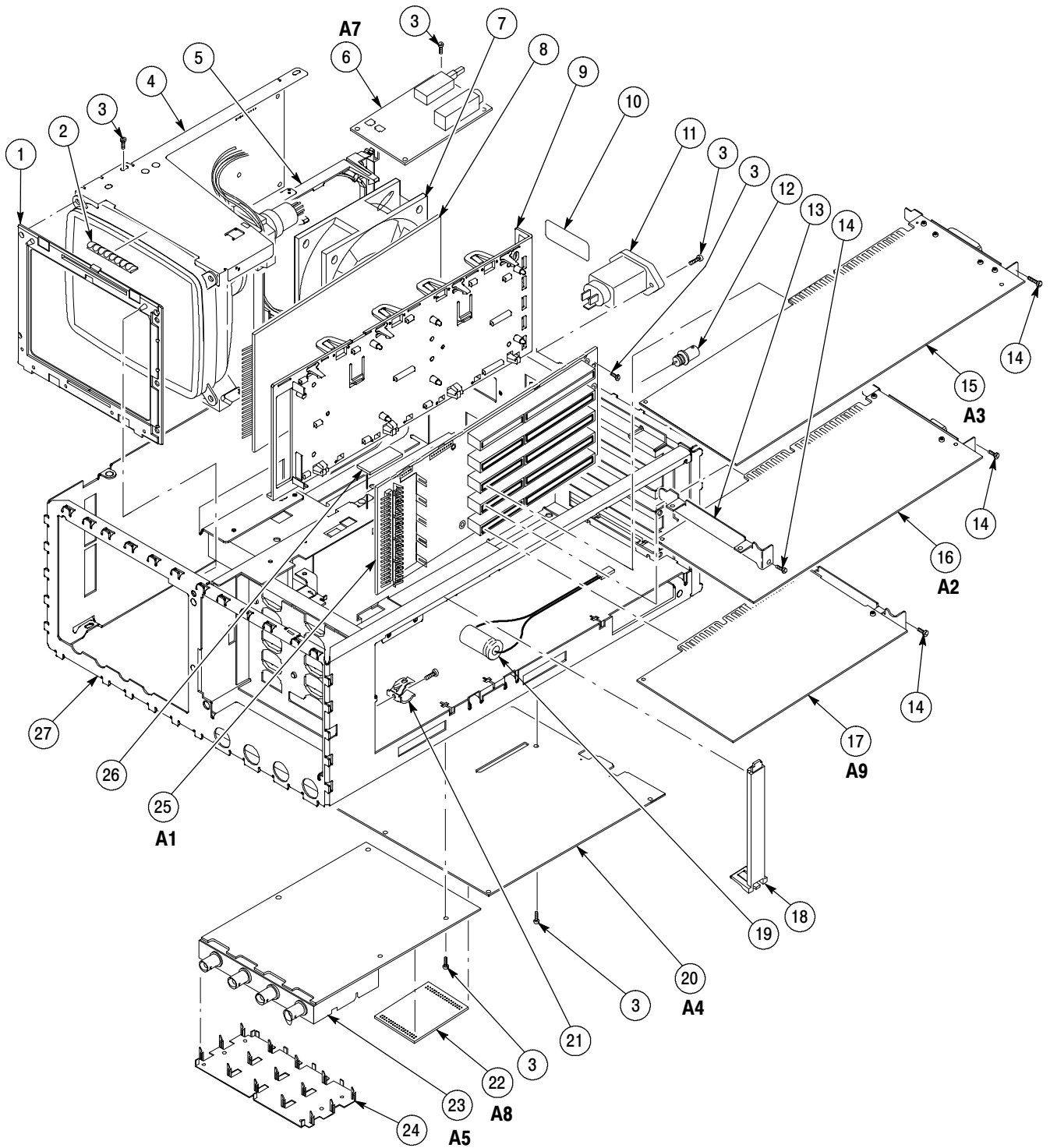

Figure 10-2: Internal modules (B010100 - B079999)

Fig. & Index No.	Tektronix Part No.	Serial No. Effective Dscont	Qty	Name & Description	Mfr. Code	Mfr. Part No.
B080000 - UP						
10-3-1	426-2436-01		1	FRAME,CRT FLTR:POLYCARBONATE	TK1163	ORDER BY DESC
-2	348-1291-00		2	SHLD,GSKT ELEK:CLIP-ON EM GASKET	30817	9760-5090-20
-3	213-0882-00		31	SCREW,TPG,TR:6-32 X 0.437 TAPTITE,PNH,STL	0KB01	ORDER BY DESC
-4	640-0079-02		1	DISPLAY MODULE:7 INCH, MONOCHROME P31	80009	640007902
-5	426-2426-00		1	FRAME,FAN MTG:POLYCARBONATE	80009	426242600
-6	407-4491-01		1	BAFFLE,AIR:AL	TK1935	407-4491-00
-7	211-0722-00		4	SCREW,MACHINE:6-32 X 0.25,PNH,STL	0KB01	ORDER BY DESC
-8	213-0978-00		1	SCREW,TPG,TR:6-32 X 0.500,FLH100,STL,CDPL,T-10	0KB01	ORDER BY DESC
-9	129-1552-00		1	SPACER,POST:0.660 OVERALL,0.440H,0.25 HEX,W/6-32 EXT THD X ,6-32 THD,STUD,0.200 MIN INT THD,	TK0588	129-1450-01
-10	119-1770-00		1	FAN ASSEMBLY:12VDC,1.72W,35CFM W/CONN	S4246	CUDC12D4
-11	119-5557-02		1	POWER SPLY:CUSTOM,AC-DC,225W,90-132/180-250VAC IN,5.1V 15A 15V 3.5A -6.4V	26003	119-5557-02
-12	119-6486-00		1	POWER SUPPLY:300W,PFC MODULE,85-275VAC 45-66HZ 95-132VAC 360-440HZ 6A IN,400VDC 0.75A OUT,85%	26003	PS2290
-13	386-6159-00		1	SUPPORT,CKT BD:BACK PLANE & PWR SPLY	80009	386615900
-14	334-3003-00		1	MARKER,IDENT:DANGER POWER LINE	TK0860	ORDER BY DESC
-15	131-0955-00		1	CONN,RF JACK:BNC,50 OHM,FEMALE,STR	00779	87-3334-017
-16	407-4032-00		2	BRACKET,CKT BD:	80009	407403200
-17	671-3268-01		1	CIRCUIT BD ASSY:CPU	80009	671326801
-18	671-3902-00		1	CIRCUIT BD ASSY:DISPLAY	80009	671390200
-19	671-3588-00		1	CIRCUIT BD ASSY:DSP (STANDARD)	80009	671358800
	671-3284-00		1	CIRCUIT BD ASSY:DSP (OPTION 1M)	80009	671328400
-20	386-6158-00		3	SUPPORT,CKT BD:MAT MATERIAL	80009	386615800
-21	146-0056-02		2	BATTERY:3V,1200MAH,2/3A LITHIUM BATTERY	0DWW6	ORDER BY DESC
-22	671-3597-01		1	CIRCUIT BD ASSY:ACQUISITION (TDS420A ONLY)	80009	671359701
	671-1685-12		1	CIRCUIT BD ASSY:ACQUISITION (TDS460A ONLY)	80009	671168512
	671-3980-00		1	CIRCUIT BD ASSY:ACQUISITION (TDS430A ONLY)	80009	671398000
-23	344-0116-00		2	RTNR,CAPACITOR:0.625 DIA,STEEL	TK1891	E50003-007
-24	671-1683-00		1	CIRCUIT BD ASSY:JUMPER	80009	671168300
-25	671-3595-01		1	CIRCUIT BD ASSY:ATTENUATOR (TDS420A ONLY)	80009	671359501
	671-1686-07		1	CIRCUIT BD ASSY:ATTENUATOR (TDS460A ONLY)	80009	671168607
	671-3979-00		1	CIRCUIT BD ASSY:ATTENUATOR (TDS430A ONLY)	80009	671397900
-26	337-3713-01		1	SHIELD,ELEC:ATTENUATOR	TK1935	337371301
-27	671-1676-03		1	CIRCUIT BD ASSY:BACKPLANE	80009	671167605
-28	200-3660-00		1	COVER,AUTO CAL:POLYCARBONATE	TK1163	ORDER BY DESC
-29	441-2072-01		1	CHASSIS ASSY:ALUMINUM	80009	441207200

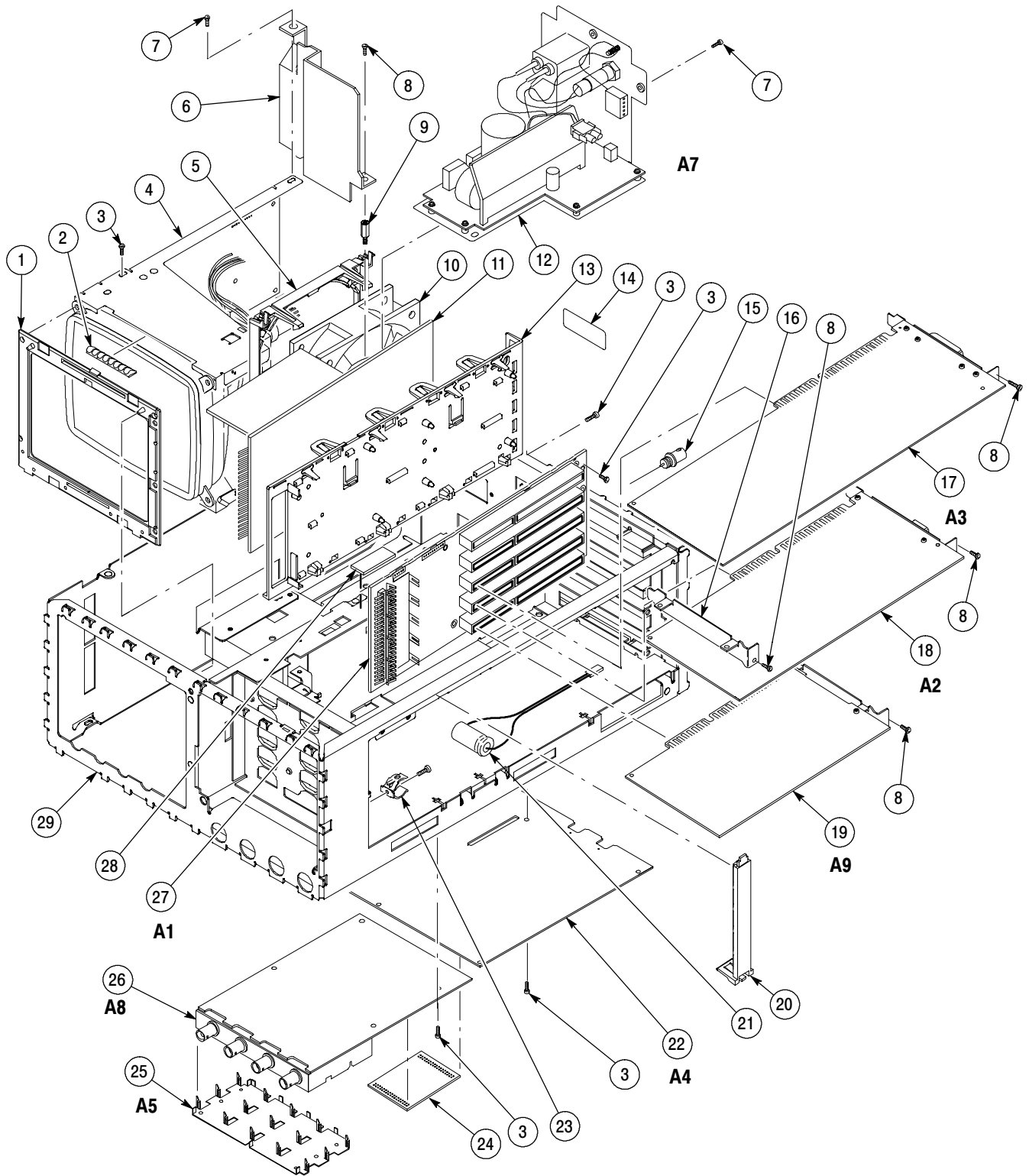

Figure 10-3: Internal modules (B080000 - Up)

Fig. & Index No.	Tektronix Part No.	Serial No.		Qty	Name & Description	Mfr. Code	Mfr. Part No.
		Effective	Dscont				
B010100 - B079999							
10-4-1	174-2661-00			1	CABLE,SP,ELEC:18 AWG,AMP	TK2469	174-2661-00
-2	174-2282-00			1	CA ASSY,SP,ELEC:FLAT FLEX,15.8L	TK2469	174-2282-00
-3	276-0849-00			2	CORE,EM:EMI SUPPRESS,RBN CA,RECTANGLE	1JJ96	BFS 33.5X8X6.5 SLOT 27
-4	253-0176-00			1	TAPE,PRESS SENS:VINYL FOAM,0.5 X 0.062	2K262	ORDER BY DESC
-5	174-2283-00			2	CA ASSY,SP,ELEC:FLAT FLEX,11.0L	TK2469	174-2283-00
-6	174-2373-00			1	CA ASSY,SP,ELEC:2,18 AWG,2.0 L	TK2469	174-2373-00
-7	174-2288-00			1	CA ASSY,SP,ELEC:DESCETE,PSC,3.5L	TK2469	174-2288-00
-8	210-0457-00			2	NUT,PL,ASSEM WA:6-32 X 0.312,STL CD PL	TK0435	ORDER BY DESC
-9	174-2631-00			1	CABLE ASSY,PWR:1460 PVC,18 AWG	TK2469	174-2631-00
-10	174-2281-01			1	CA ASSY,SP,ELEC:50,28 AWG,2.3 L,FLAT CABLE	TK2469	ORDER BY DESC
-11	174-2280-00			1	CA ASSY,SP,ELEC:FLAT FLEX,1.7L	TK2469	174-2280-00
-12	174-2278-00			1	CA ASSY,SP,ELEC:FLAT FLEX,2.5L	TK2469	174-2278-00
-13	174-3135-00			1	CABLE ASSY,SP:FLAT,FLX,26,1MM,15.0L (DISK DRIVE)	80009	174313500
-14	174-2284-00			1	CA ASSY,SP,ELEC:FLAT FLEX,8.8L	80009	174228400

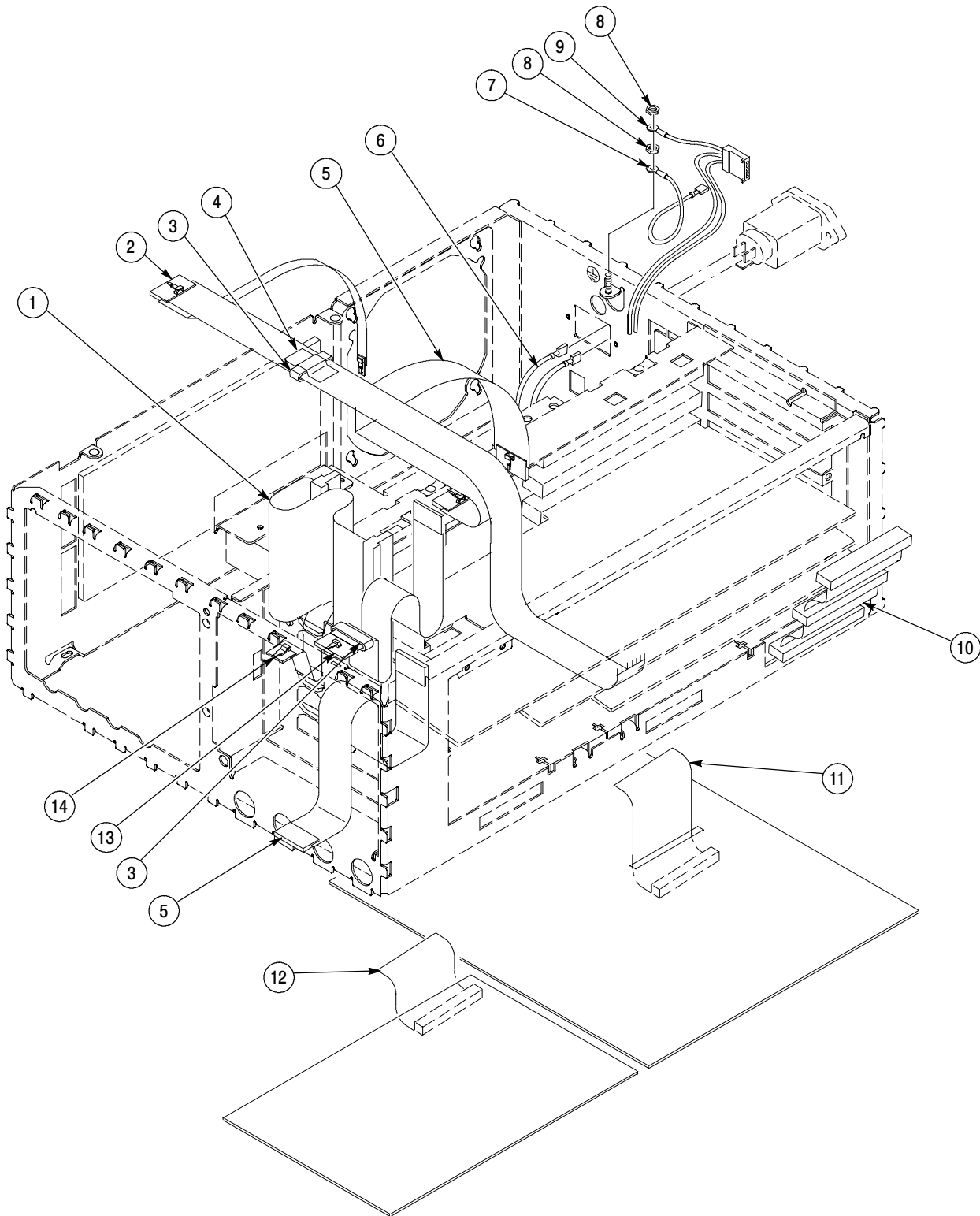

Figure 10-4: Cables and routing (B010100 - B079999)

Fig. & Index No.	Tektronix Part No.	Serial No.		Qty	Name & Description	Mfr. Code	Mfr. Part No.
		Effective	Dscont				
B080000 - UP							
10-5-1	174-2661-00			1	CABLE,SP,ELEC:18 AWG,AMP	TK2469	174-2661-00
-2	174-2282-00			1	CA ASSY,SP,ELEC:FLAT FLEX,15.8L	TK2469	174-2282-00
-3	276-0849-00			2	CORE,EM:EMI SUPPRESS,RBN CA,RECTANGLE	1JJ96	BFS 33.5X8X6.5 SLOT 27
-4	253-0176-00			1	TAPE,PRESS SENS:VINYL FOAM,0.5 X 0.062	2K262	ORDER BY DESC
-5	174-4557-00			1	CA ASSY,SP:FLAT FLEX,FLX,10,26 AWG,12.0 L,1 X 10,0.1 CTR,RCPT,LATCHING BOTH ENDS,OPPOSING S	060D9	174-4557-00
-6	174-2288-00			1	CA ASSY,SP,ELEC:DESCETE,PSC,3.5L	TK2469	174-2288-00
-7	174-2281-01			1	CA ASSY,SP,ELEC:50,28 AWG,2.3 L,FLAT CABLE	TK2469	ORDER BY DESC
-8	174-2280-00			1	CA ASSY,SP,ELEC:FLAT FLEX,1.7L	TK2469	174-2280-00
-9	174-2278-00			1	CA ASSY,SP,ELEC:FLAT FLEX,2.5L	TK2469	174-2278-00
-10	174-3135-00			1	CABLE ASSY,SP:FLAT,FLX,26,1MM,15.0L (DISK DRIVE)	80009	174313500
-11	174-2284-00			1	CA ASSY,SP,ELEC:FLAT FLEX,8.8L	80009	174228400

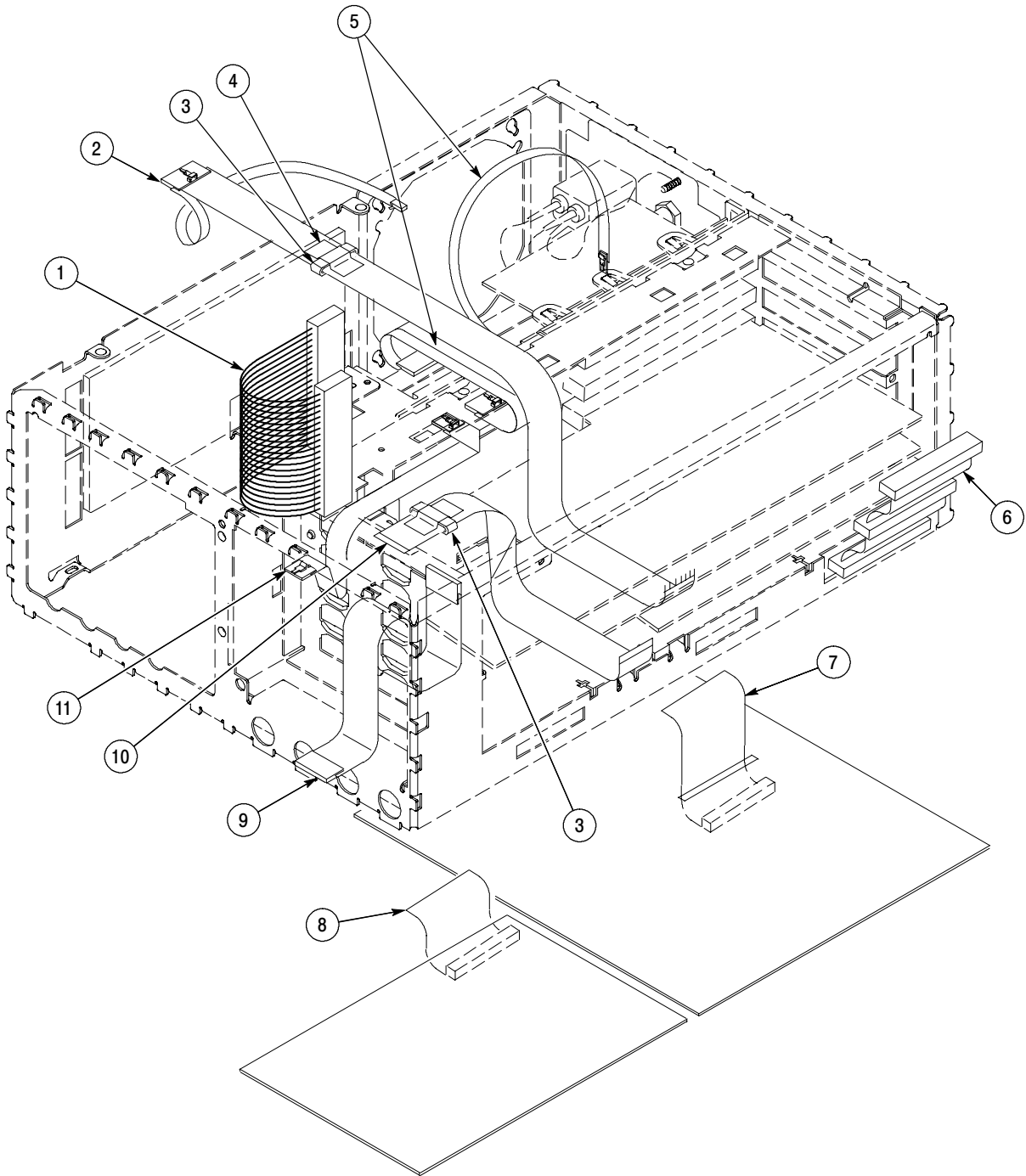

Figure 10-5: Cables and routing (B080000 - Up)

Fig. & Index No.	Tektronix Part No.	Serial No. Effective	Dscont	Qty	Name & Description	Mfr. Code	Mfr. Part No.
STANDARD ACCESSORIES							
-----				1	ACCESSORY PKG:(2) P6138A 1.3M PROBES		
070-9701-XX				1	MANUAL,TECH:TUTORIAL/USER,ENGLISH	80009	0709701XX
020-2192-XX				1	MANUAL,TECH:QUICK REF	80009	0202192XX
070-9703-XX				1	MANUAL,TECH:SERVICE	80009	0709703XX
070-9705-XX				1	MANUAL,TECH:PERFORMANCE VERIFICATION	80009	0709705XX
-----				1	CABLE ASSY,PWR,;3,18 AWG,92 L,SVT,TAN (STANDARD-SEE FIGURE 10-1-8)	TK2432	ORDER BY DESC
161-0104-05				1	CABLE ASSY,PWR,;3,18 AWG,240V,98.0 L (OPTION A3-AUSTRALIAN)	S3109	SAA/3-OD3CCFC3X
161-0104-06				1	CABLE ASSY,PWR,;3 X 0.75MM SQ,220V,98.0 L (OPTION A1-EUROPEAN)	S3109	VIIGSOPO-HO5VVF
161-0104-07				1	CABLE ASSY,PWR,;3,1.0MM SQ,240 VOLT,2.5 M (OPTION A2-UNITED KINGDOM)	S3109	ORDER BY DESC
161-0104-08				1	CABLE ASSY,PWR,;3,18 AWG,98 L,SVT,GREY/BLK (OPTION A4-NORTH AMERICAN)	70903	ORDER BY DESC
161-0167-00				1	CABLE ASSY,PWR,;3.0 X 0.75,6A,240V,2.5M L (OPTION A5-SWITZERLAND)	S3109	ORDER BY DESC
-----				1	CLAMP,PWR CORD:POLYIMIDE (SEE FIGURE 10-1-9)	TK1163	ORDER BY DESC
OPTIONAL ACCESSORIES							
003-1463-00				1	WRENCH,BNC:WRENCH FOR BNC FIXTURE	80009	003146300
003-1464-00				1	FIXTURE,BNC:BNC FIXTURE FOR TDS400	80009	003146400
012-0991-00				1	CABLE,COMPOSITE:IDC,GPIB:2 METER,24 COND	00779	553577-3
012-0991-01				1	CABLE,GPIB:LOW EMI,1 METER	00779	553577-2
016-1154-00				1	HOOD ASSEMBLY:2KDSO	80009	016115400
016-1157-00				1	CASE,CARRYING:26 X 22 X 12,HARD TRANSFER	34416	ORDER BY DESC
016-1158-01				1	CASE,CARRYING:SOFT PADDED,OPTIONS	80009	016115801
016-1166-00				1	RACK MOUNT KIT:RACK MOUNT TDS400	80009	016116600
063-2634-00				1	SOFTWARE PKG:FIELD ADJUST	80009	063263400
067-0208-00				1	FIXTURE,CAL:RECOVERING TIME	80009	067020800
-----				1	COVER,FRONT:ASB (SEE FIGURE 10-1-22)		
070-8521-XX				1	MANUAL,TECH:RACKMOUNT (OPTION 1R ONLY)	80009	0708521XX
070-8567-XX				1	MANUAL,TECH:RS-232/CENTRONICS (OPTION 13 ONLY)	80009	0708567XX
070-8722-XX				1	MANUAL,TECH:INSTRUCTION (TDS4F5P ONLY)	80009	0708722XX
070-8762-XX				1	MANUAL,TECH:USER,VIDEO DISPLAY (OPTION 05 ONLY)	80009	0708762XX