

Instruction Manual

Tektronix

**1725 (SN B020000 & Up)
PAL/NTSC Vectorscope
070-7635-01**

Valuetronics International, Inc.
1-800-552-8258
MASTER COPY

**Please check for change information at the rear
of this manual.**

First Printing October 1993
Revised February 1994

Safety Summary

This summary contains general safety information for operating and servicing personnel. Specific warnings and cautions are given throughout the manual where they apply, but may not appear in this summary.

TERMS

In this manual

CAUTION statements identify conditions or practices that can damage the equipment or other property.

WARNING statements identify conditions or practices that can cause injury or loss of life.

As marked on equipment

CAUTION indicates an injury hazard not immediately accessible as one reads the marking, or a hazard to the equipment or other property.

DANGER indicates an injury hazard immediately accessible as one reads the marking.

SYMBOLS

In this manual



This symbol shows where applicable cautionary or other information is to be found.

As marked on the equipment



DANGER — High voltage.



Protective ground (earth) terminal.



ATTENTION — refer to manual.

Danger arising from loss of ground

If the protective connection to ground is lost, all accessible conductive parts (including knobs and controls that may appear to be insulated) can render an electric shock.

Use the proper fuse

Use only the fuse of correct type, voltage rating, and current rating, as specified in the parts list for the product. Refer fuse replacement to qualified personnel.

Do not operate in an explosive atmosphere

Do not operate this product in an explosive atmosphere unless it has been specifically certified for such operation.

Do not operate without covers

To avoid injury, do not operate the product without its covers and panels properly installed.

Power supply shield

The plastic shield on the power supply board is required for protection from dangerous voltages that are present on the board. This shield must be in place at all times when operating the instrument.

Section 1

Introduction

The TEKTRONIX 1725 is an 8½" wide by 5¼" high Vectorscope, weighing 8½ pounds. The 1725 can be powered from an ac source or, with the addition of a field upgrade kit (1700F10), 12 Vdc. The crt occupies approximately two-thirds of the front-panel area, with the control panel taking up the remainder of the space.

Operation is controlled by a microprocessor that polls the front-panel switches. Front-panel switches are of the momentary touch type with lighted functional indicators. In addition, some of the switches are used to select special functions. Special functions are accessed by holding the switches in until the microprocessor recognizes the request.

The signal is displayed on a bright crt capable of displaying one line per frame. It is of the mesh type for better geometry, and uses an internal graticule to reduce parallax. The internal vector graticule has targets for both NTSC and PAL color signals that are scaled for both 75% and 100% amplitude color bars. Variable graticule scale illumination provides even lighting over the usable graticule area to improve measurement accuracy and the quality of waveform photographs.

Composite video signals, for the Channel A and B Inputs, and the External Reference Signal Input are brought in through high impedance bridging loopthroughs in order to protect the integrity of the signal paths. The input switching allows for the display of either Channel A or Channel B or both inputs. Synchronization can be either internal or external.

The 1725 offers a choice of individual displays of vectors or X-Y or both. The X-Y display, with accompanying graticule scale, allows this vectorscope to be used for stereo audio monitoring. Stereo audio balanced line input for X-Y display is through the rear-panel REMOTE connector. In addition to the usual color bar amplitude and phase relationships, the vector display can also be used to make differential gain and phase measurements. A +V display is used to check PAL system color encoders. Full 360° phase shift and a test circle are also included in this vectorscope.

The 1725, through the Auxiliary function, reacts to Store and Recall commands from a companion 1730-Series Waveform Monitor, when the two are interconnected. This allows the storing of up to four front-panel setups that can be recalled when a waveform monitor recall button is pressed, or a valid 1730-Series Remote ground closure occurs. The Auxiliary function can also take advantage of the blanking strobe from the waveform monitor, to unblank the Vectorscope crt for up to 1-line in 625-line select display.

Accessories

The 1725 is shipped with a set of accessories that are needed for its installation or day-to-day operation. These are the "Standard Accessories." They are packaged in a small, cardboard carton within the packing box.

In addition to the standard accessories, there are other accessory items that can be purchased from Tektronix, Inc., that will either enhance operation or help to customize the installation. The following list of accessories is divided into these two categories. Part numbers for the standard accessories can be found at the end of the Replaceable Mechanical Parts List.

Standard Accessories (included with instrument)

- 1 Manual, Instruction (070-7635-XX)
- 1 Cable Assembly, Power (161-0216-00 for US/Japan only, all others 161-0066-XX)
- 1 Fuse, Cartridge: 3AG 2A, 250V, Fast-Blow (159-0021-00)
- 3 Light Bulbs, replacement for graticule scale (150-0168-00)
- 1 Auxiliary Control Cable for use with 1730-Series Waveform Monitor (012-1422-00)
- 1 Smoke Gray crt Filter (378-0258-00) – Installed

Optional Accessories (ordered separately)

- Camera, C9 (Option 20)
- Viewing Hood (016-0475-00)
- Front Panel Cover (200-3897-01)

Field-Installable Upgrades

- 1700F00, Plain Cabinet (painted silver grey)
- 1700F02, Portable Cabinet (silver grey)
- 1700F05, Side-by-Side Rack Adapter
- 1700F06, Blank Half-Rack-Width Panel
- 1700F10, DC Power Converter

Power Cord Options

The 1725 is available with the following optional power cords.

Option A1 Power, Universal Europe, 220 V/16 A (Power Cord and 2 Fuses).

Option A2 Power, United Kingdom, 240 V/15 A (Power Cord and 2 Fuses).

Option A3 Power, Australia, 240 V/10 A (Power Cord and 2 Fuses).

Option A4 Power, North America, 250 V/10 A (Power Cord and 2 Fuses).

Option A5 Power, Swiss, 240 V/6 A (Power Cord and 2 Fuses).

If the 1725 is ordered without specifying a Power Cord Option, it is shipped with a standard 3-prong, 120 volt power plug.

Safety Information

The 1725 is intended to operate from an ac power source that will not apply more than 250 V rms between the supply conductors or between either supply conductor and ground. A protective ground connection by way of the grounding conductor is essential for safe operation.

The 1725 was tested for compliance in a cabinet. To ensure continued compliance, the instrument will need to be enclosed in a cabinet that is equivalent to the Factory Upgrade Kits that are listed as Optional Accessories for the 1725. A drawing of the 1700F00 (plain cabinet) is contained in the Installation Instructions (Section 3).

The 1725 is designed and tested in accordance with the following industry safety standards:

UL1244–1980 — Standard for Electrical and Electronic Measuring and Testing Equipment.

FM. 3820 — Approval Standard for Electrical Utilization Equipment, Class Number 3820.

ANSI C39.5 — Safety Requirements for Electrical and Electronic Measuring and Controlling Instrumentation, 1974.

CSA — Electrical Bulletin No. 556B.

IEC 348, Second Edition — Safety Standard for Electronic Measuring Apparatus.

VDE 0871.5 (Class B) — Radio Frequency Interference Suppression of Electrical Equipment and Systems.

Specification

The Performance Requirements listed here apply over an ambient operating temperature range of 0 to 50° C and are valid only when the instrument is calibrated at 25° ±5° C, following a minimum warm-up period of 20 minutes.

Procedure and the list of test equipment required to verify Performance Requirements are located in Section 5.

Table 1-1: Signal and External Reference Inputs

CHARACTERISTIC	PERFORMANCE REQUIREMENTS	SUPPLEMENTAL INFORMATION	CHECK STEP
Return Loss (75W) Video Inputs (CH-A, CH-B) EXT REF	±40 dB from 50 kHz to 6 MHz.	Loophrough terminated in 75Ω. Input in use or not, instrument power on or off, all deflection factor settings.	15
Crosstalk between Channels		≥70 dB of isolation between channels. Measured at F _{SC} between Channel A, Channel B, and EXT REF.	
Loophrough Isolation		≥70 dB of isolation between loophroughs. Measured at F _{SC} between Channel A, Channel B, and EXT REF.	
Input Requirements	Stable display with Composite video, or black burst with 286 mV (NTSC), 300 mV (PAL) burst ±6 dB.		3
Dc Input Impedance (Unterminated)	≥15 kW.		
EXT REF Input		Composite video. (Can be CW Subcarrier if two internal jumpers are moved.)	
Absolute Maximum Input Voltage		±12 Vdc plus peak ac.	
Maximum Operating Input Voltage		Peak ac + dc should be within +8.0 V and -5.6 V for proper operation.	

Table 1-2: Vector Mode

CHARACTERISTIC	PERFORMANCE REQUIREMENTS	SUPPLEMENTAL INFORMATION	CHECK STEP
Chrominance Processing Characteristics			
Nominal Subcarrier Frequency (F_{SC})			
NTSC		3.579545 MHz.	
PAL		4.43361875 MHz.	
Chrominance Bandwidth			
Upper -3 dB Point	$F_{SC} + 500 \text{ kHz}, \pm 100 \text{ kHz}.$		4
Lower -3 dB Point	$F_{SC} - 500 \text{ kHz}, \pm 100 \text{ kHz}.$		4
+V		+V type display as selected by front-panel button. When pushed, V axis is inverted at a $\frac{1}{2}$ line rate to produce a single vector display of the PAL signal.	5
Display			
Vector Phase Accuracy	$\pm 1.25^\circ$	Measured with color bar signal.	5
Vector Gain Accuracy		Typically $\pm 2.5\%$.	5
Quadrature Phasing		Typically $\pm 0.5^\circ$.	
Subcarrier Regenerator		Subcarrier Regenerator freeruns in absence of appropriate signal. Reference can be burst of either displayed signal or external reference signal.	
Pull-In Range			
NTSC	$\pm 50 \text{ Hz of } F_{SC}.$		6
PAL	$\pm 10 \text{ Hz of } F_{SC}.$		6
Pull-In Time		Within 1 second, with subcarrier frequency within 50 Hz (10 Hz for PAL) of $F_{SC}.$	6
Auto Phase Lock			
Lock-in Time	< 1.5 Seconds		11
Accuracy	$\pm 2^\circ$	Measured with burst at compass rose.	11
Phase Shift with Subcarrier Frequency Change			
NTSC	$\pm 2^\circ$ from F_{SC} to ($F_{SC} + 50 \text{ Hz}$), or F_{SC} to ($F_{SC} - 50 \text{ Hz}$).		6
PAL	$\pm 2^\circ$ from F_{SC} to ($F_{SC} + 10 \text{ Hz}$), or F_{SC} to ($F_{SC} - 10 \text{ Hz}$).		6
Phase Shift with Burst Amplitude Change	$\pm 2^\circ$ from nominal burst amplitude to $\pm 6 \text{ dB}.$	Internal or external burst reference.	6
Phase Shift with Input Channel Change	$\pm 0.5^\circ$.	With EXT REF selected.	7
Phase Shift with VAR GAIN Control	$\pm 1^\circ$ as gain is varied from 3 dB to -6 dB.		7
PHASE Control Range		360° continuous rotation.	

Table 1–2: Vector Mode (Cont.)

CHARACTERISTIC	PERFORMANCE REQUIREMENTS	SUPPLEMENTAL INFORMATION	CHECK STEP
Burst Jitter	0.5° rms or less.	With 140 IRE (1 V) composite video input. INT or EXT referenced.	7
Display Characteristics			
Differential Phase	± 1°.	Measured with 140 IRE (1 V) linearity signal (5 step, 10 step, or Ramp) with 40 IRE (300 mV) of subcarrier.	8
Differential Gain	± 1%.		8
Position Control Range			
HORIZONTAL	At least 1/4" (6 mm) from center.		9
VERTICAL	At least 1/4" (6 mm) from center.		9
Clamp Stability	1/64" (0.4 mm) or less.	Center Spot Movement with Rotation of PHASE Control.	9
Variable GAIN Range	+14 dB to –6 dB of 75% color bar preset gain.	+5 to –1/2 amplitude.	10

Table 1–3: X Y Mode

CHARACTERISTIC	PERFORMANCE REQUIREMENTS	SUPPLEMENTAL INFORMATION	CHECK STEP
Input		DC Coupled differential inputs through rear-panel REMOTE connector.	
Input Amplitude	2 to 9 V p–p.	Adjustable full scale deflection 0 dBm to +12 dBm for 600W system. Factory set to 0 dBm.	
Maximum Input Voltage	+ or –15 V peak signal plus dc.		
Frequency Response	Dc to greater than 200 kHz.	3 dB point.	14
High Gain Mode	Dc to greater than 100 kHz.	3 dB point. Not a differential input, minus inputs must be grounded.	14
X and Y Input Phase Matching	Less than a trace width of separation at 20 kHz.	Singleended. Phase matching may be improved, above 20 kHz, by adjustment.	13

Table 1-4: CRT Display

CHARACTERISTIC	PERFORMANCE REQUIREMENTS	SUPPLEMENTAL INFORMATION	CHECK STEP
CRT Viewing Area		80 X 100 mm.	
Accelerating Potential		13.75 kV.	
Trace Rotation Range	Greater than $\pm 1^\circ$ from horizontal.	Total adjustment range is typically 8° .	12
Graticule		Internal Vector, variable SCALE illumination.	

Table 1-5: Power Source

CHARACTERISTIC	PERFORMANCE REQUIREMENTS	SUPPLEMENTAL INFORMATION	CHECK STEP
Mains Voltage Ranges	90–250 V.		2
Mains Frequency Range	48 Hz to 66 Hz.		
Power Consumption		25 Watts (85 BTU/HR) maximum.	

Table 1-6: Environmental Characteristics

CHARACTERISTIC	SUPPLEMENTAL INFORMATION
Temperature Non-Operating Operating	-55°C to $+75^\circ\text{C}$. 0°C to $+50^\circ\text{C}$.
Altitude Non-Operating Operating	To 50,000 feet. To 15,000 feet.
Vibration – Operating	15 minutes each axis at 0.015 inch, frequency varied from 10–55–10 Hz in 1-minute cycles with instrument secured to vibration platform. Ten minutes each axis at any resonant point or at 55 Hz if no resonant point is found.
Shock – Non-Operating	30 g's, 1/2 sine, 11 ms duration, 3 shocks per surface (18 total).
Transportation	Qualified under NTSC Test Procedure 1A, Category II (30-inch drop).
Humidity	Will operate at 95% relative humidity for up to five days. Do not operate with visible moisture on the circuit boards.

Table 1–7: Certification

CHARACTERISTIC	SUPPLEMENTAL INFORMATION
Safety/EMI	Designed to meet or exceed: UL – 1244 Factory Mutual – 3820 CSA Bulletin 556B IEC 348 FCC EMI Compatibility (FCC Rules Part 15 Subpart J, Class A) VDE 0871.5 (Class B)

Table 1–8: Physical Characteristics

CHARACTERISTIC	SUPPLEMENTAL INFORMATION
Dimensions	
Height	5 1/4 inches (133.4 mm).
Width	8 1/2 inches (215.9 mm).
Length	18 1/8 inches (460.4 mm).
Weight	8.5 lbs (3.8 kg).

Section 2

Operating Instructions

These instructions provide information about the front-panel controls, rear-panel connectors, the Operator's Familiarization/Checkout Procedures, and discussions about vector and audio measurements using the 1725.

Front-Panel Controls and Indicators

The front-panel controls and indicators consist of momentary contact push-button switches, variable controls, and back-lit switch selections. See Figure 2-1 for the control and indicator locations.

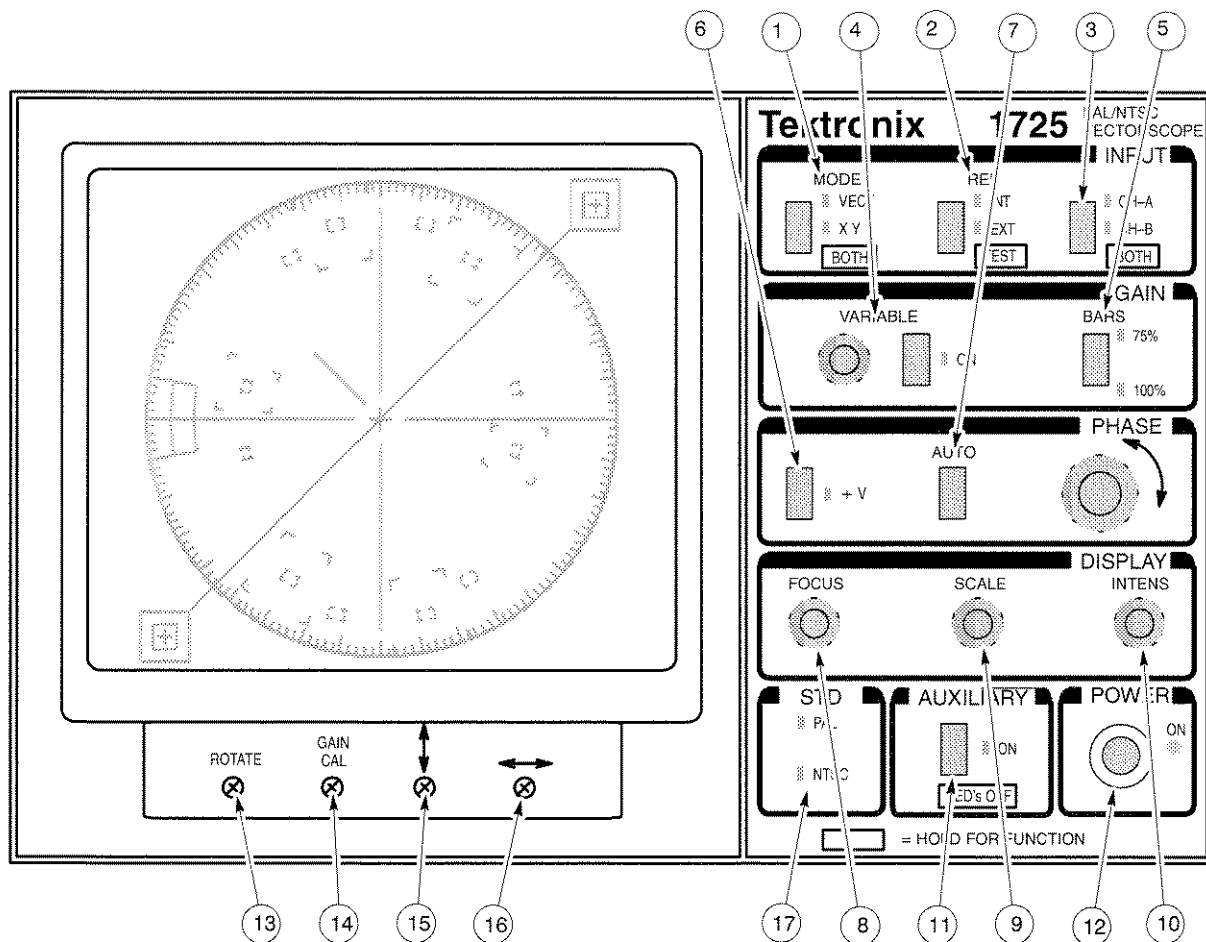

Figure 2-1: 1725 front panel controls and indicators

There are three push-button switches, located in the INPUT block, that have extra functions. The extra function is accessed by holding the switch down for approximately one second. The operating selection reverts to the top of the listed functions, when the push button is repushed to exit this function, with the exception of TEST, which reverts to its original state.

INPUT

1. MODE

A momentary push-button switch that toggles between the vector and XY displays. These two functions have back lighted nomenclature with rectangular indicators.

Holding this button in switches the MODE to a combination display of vector and XY. In this mode both the VECT and XY nomenclature and rectangular indicators light to indicate that the 1725 has been switched into this mode.

2. REF

A momentary push-button switch that toggles between INT and EXT sync references. These two functions have back lighted nomenclature with rectangular indicators.

Holding this button in switches the REF to an unlocked display of subcarrier and enables the V-axis switcher, if a signal containing a subcarrier reference signal is applied to the selected input. TEST nomenclature, framed by a blue box, lights up when the 1725 is in this mode.

3. A B

Momentary contact push-button switch that toggles the input between A and B. Back lighted nomenclature, with rectangular indicators, light to show which is selected for display.

Holding this button in switches the INPUT to a display of both A and B Inputs. This display requires an external sync reference. Both the CH-A and CH-B indicators light when the 1725 has been switched to this dual input mode. If the internal phase shifter jumper has been changed to dual, one indicator will be flashing to indicate which input the front-panel PHASE control is working with. See Section 3 (Installation) for details.

Both input signals must be of the same standard to obtain a meaningful BOTH display.

In dual phase shift mode, touching the AB switch changes the PHASE shifter to the opposite input. The front-panel LED blinks to indicate which input the PHASE control is active on.

In the “Tracks Channel” position of the internal jumper (factory shipped), touching the AB switch exits the AB mode of operation. When “Dual Phase” position has been selected the CHA–CHB switch must be held in to exit AB mode.

GAIN

4. VARIABLE

A momentary contact push-button switch that toggles between variable gain ON and off. The VARIABLE control adjusts amplifier input gain so that any input signal between 0.5 V and 2.0 V can be displayed. Control has no detent, action is continuous. Back lighted nomenclature, with rectangular indicators, lights up red to indicate that display gain is uncalibrated.

5. BARS

A momentary contact push-button switch that toggles between correct gain for displaying 75% and 100% amplitude color bar signals, using a single set of vector targets. Burst targets for both 75% and 100% amplitude color bars are on the graticule. Back lighted nomenclature, with rectangular indicators, lights to indicate which amplitude color bars the 1725 is set up to measure.

PHASE

6. +V (PAL only)

A momentary contact push-button switch that selects +V. It selects an overlaid +V with –V display on the +V Axis for alternate line comparisons. Back lighted nomenclature, with rectangular indicators, lights to indicate that either standard PAL or overlaid + and –V is being displayed.

7. AUTO

A momentary contact push-button switch that returns the burst(s) for the selected standard to the graticule target(s).

PHASE Control

A continuously-variable control with 360° range to set the phase of the decoder reference.

Display

8. FOCUS

A 270° rotation potentiometer that is adjusted for display definition.

9. SCALE

A 270° rotation potentiometer that controls the level of graticule illumination.

10. INTENS

A 270° rotation potentiometer that controls display brightness.

Miscellaneous

11. AUXILIARY

Toggles between AUXILIARY and independent operation. In the AUXILIARY mode, a Line Strobe (to blank the 1725 crt, for line selection) and data to actuate the front-panel setup is accepted from a companion 1730-Series. Back lighted nomenclature, with rectangular indicators, lights to indicate that the instrument is under AUXILIARY control.

Pushing and holding the AUXILIARY switch causes the front-panel LED indicators to extinguish. Pushing any front-panel button turns all front-panel indicators back on.

12. POWER

Turns on and off external power to the 1725. Contains a mechanical indicator that indicates the status of the POWER switch, even when the mains power is disconnected or shut down from another location.

13. ROTATE

A 270° rotation screwdriver adjustment that aligns the display with the graticule.

14. GAIN CAL

A 270° rotation screwdriver adjustment that sets the amplifier gains in the Vector Mode.

15. VERT POS

A 270° screwdriver-adjustable, variable control that provides limited vertical positioning of the display.

16. HORIZ POS

A 270° screwdriver-adjustable, variable control that provides limited horizontal positioning of the display.

17. STANDARD

Back lighted indicators that are used to show which color standard is being displayed. Standard is automatically selected by the 1725 subcarrier frequency sensing.

Rear-Panel Connectors

Signal input, power input, Auxiliary Control In, XY Input, and Demod Out are all located on the 1725 rear panel. Because of the similarity of the 1730-Series to the 1725 rear panel, the word **VECTORSCOPE** appears at the top of the panel. See Figure 2-2 for locations of rear-panel connectors.

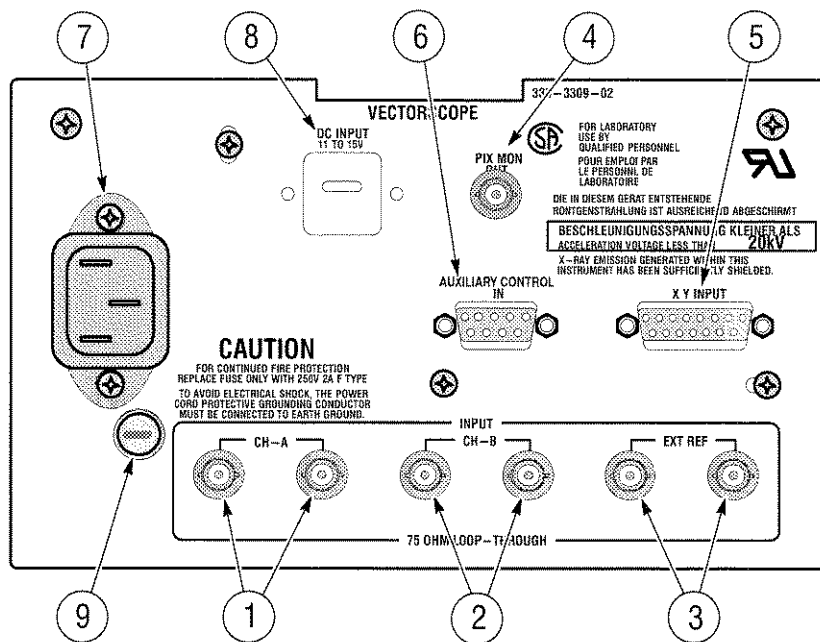

Figure 2-2: 1725 rear panel

BNC Connectors

1. CH-A

A bridging loop-through input for composite video signal, compensated for 75Ω . The input signal for display is selected by the front-panel INPUT switch.

2. CH-B

A bridging loop-through input for composite video signal, compensated for 75Ω . The input signal for display is selected by the front-panel INPUT switch.

3. EXT REF

A bridging loop-through input (compensated for 75Ω) for synchronizing signals. As factory shipped, the input signal may be black burst or composite video. Changing a pair of internal plug jumpers makes it possible to use CW Subcarrier as an external reference; however, horizontal (line) sync must be present on the CH-A INPUT for synchronization. See Section 3 (Installation) for details. External reference is selected by the front-panel REF switch.

4. DEMOD OUT

A 75Ω output of the demodulated R-Y signal that can be fed into a companion 1730-Series to provide a horizontal sweep of demodulated video.

Subminiature D-Type Connectors

5. XY INPUT

A 15-pin connector that is used for the differential input of a stereo audio signal that is to be displayed in the XY mode. One set of inputs can be configured for high gain single-ended input. Internal jumpers must be repositioned for this type of input. See Section 3 (Installation) for more information.

6. AUXILIARY

A 9-pin connector used to interface with the 1730-Series. Auxiliary control consists of a signal line (Line Strobe) and a serial interface. The serial interface allows the 1725 to operate in conjunction with the 1730-Series Store/Recall function.

Power Input

7. AC POWER

A standard ac plug receptacle for the 120 or 220 Vac power mains. Plug is compatible with any of the power cord options available for the 1725 Vectorscope.

8. DC INPUT

This is a knockout for installation of a 1700F10 Field Upgrade Kit dc power plug.

Miscellaneous

9. AC FUSE

A holder for an F-type cartridge fuse which is the instrument ac mains supply fuse.

Using The 1725 In Auxiliary Mode

When the serial interface AUXILIARY cable (between the 1725 and a 1730-Series) is connected, the 1725 can be operated in the AUXILIARY mode. AUXILIARY allows the Input and Reference switching to follow the similar switches on the waveform monitor. For example, when the 1730-Series INPUT switch is changed from A to B, the 1725 INPUT switch will also change to B. Even though the vectorscope switching (INPUT and REF) follows the waveform monitor, the vectorscope INPUT and REF switches remain active so that they can be changed without changing the waveform monitor switching. The following functions can be controlled by the 1730-Series in AUXILIARY mode:

INPUT switching

REFerence switching

LINE SELECT

STORE and RECALL

INPUT Switching

INPUT switching allows the 1730-Series to select any of the three (CH-A, CH-B, or BOTH) inputs when AUXILIARY is ON. Note that the 1725 INPUT switch can be used independently, even though the instrument is in the AUXILIARY mode.

REF Switching

REF switching allows the 1730-Series to select either INT or EXT reference. It will not switch to TEST when the 1730-Series is switched to CAL. Reference

will automatically be switched to EXT if the INPUT is switched to BOTH (from either waveform monitor or vectorscope). If the 1725 REF switch is in TEST, the 1730–Series switching will not take it out of that mode.

LINE SELECT

The 1725 normal operation is full field. When it is used in AUXILIARY operating mode, the 1730–Series LINE SELECT switching controls the display on the vectorscope. It should be noted that the 1725 has no line selection capability when it is not connected to a 1730–Series Waveform Monitor.

STORE

NOTE. Use caution to retain desired 1730–Series stored configurations. Read the STORE and RECALL SETUP instructions in Section 2 of the 1730–Series Instruction manual before proceeding.

The current state of the front panel can be stored, in AUXILIARY mode, by executing the 1730–Series STORE command. When the 1730–Series STORE button is pushed, the 1725 front-panel indicators will blink to acknowledge that the command was received. The current front-panel configuration will now be stored in the 1725 NOVRAM as soon as one of the 1730–Series RECALL buttons is pushed.

Note that the indicators also blink when the 1725 is not in AUXILIARY; however, the front-panel configuration is not stored and the 1725 front panel will not change when that stored function (on the 1730–Series) is recalled.

RECALL

When the 1725 is in the AUXILIARY mode and contains stored front-panel configurations, it reacts to 1730–Series RECALLs. When one of these RECALL buttons is pushed, the stored front-panel configurations of both instruments will be recalled. All front-panel controls remain active during AUXILIARY mode, and can be used to make changes in current front-panel configurations.

During AUXILIARY operation, the 1725 front-panel indicators continue to accurately display its current front-panel configuration.

Operator's Checkout Procedure

The following procedure is provided as an aid in obtaining a display on the 1725 Vectorscope, and may be used as a check of basic instrument operation. Only instrument functions are checked in this procedure. The Performance Check procedure, used to determine if the instrument is operating within performance requirements, is located in Section 5 of this manual. All checks can be made

with a cabinet on and it is necessary to have all internal jumpers in the factory-set position.

This procedure requires two sources of composite video and composite sync signals. The TEKTRONIX 1410-Series Television Test Signal Generator mainframe with Sync, Color Bar, and Linearity modules was used as the NTSC signal source in preparing this procedure. The TEKTRONIX 1411-Series Television Test Signal Generator mainframe with Sync, Color Bar, and Linearity modules was used as the PAL signal source in preparing this procedure.

1. Initial Setup

1725 Vectorscope

MODE	VECT
REF	INT
INPUT	CH A
VARIABLE	off
BARS	75%
+V	out
PHASE	Will be set later
FOCUS	Will be set later
SCALE	Counterclockwise
INTENS	Counterclockwise
POWER	OFF

Connect the NTSC color bar signal to the CH-A INPUT and terminate the remaining side of the loop-through input with a 75 Ω termination. Connect the PAL modulated staircase signal to the CH-B INPUT. Connect the PAL black burst to the EXT REF and terminate in 75 Ω . See Figure 2-3.

Set up the signal sources for the following composite video signals:

Full Field Color Bars

75% Ampl. 7.5% Setup — NTSC

75% Ampl. 0% Setup — PAL

PAL Modulated Staircase

(Flat Field, 10 Step)

Black Burst Signal

(Sync and Burst only)

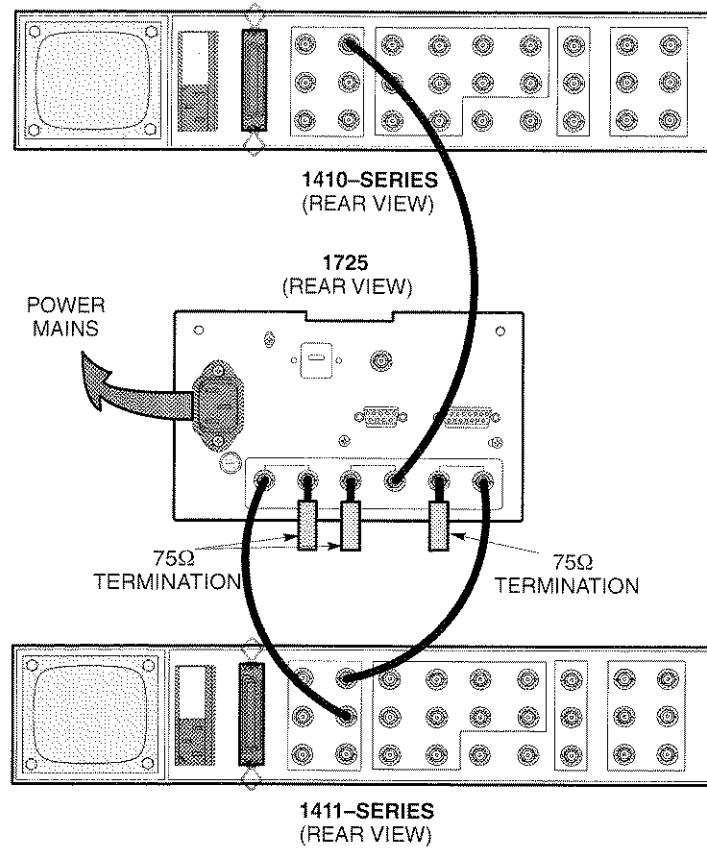

Figure 2-3: Initial equipment connections for operators checkout procedure

If the XY operation of the 1725 is to be checked, an audio signal is required. See the following:

Audio Signal: About 2 V between 1 and 100 kHz.

2. Apply Power

Connect the instrument to a suitable ac power source and push the POWER switch. Check that the indicator in the center of the switch is indicating that POWER is ON.

NOTE. Do not set any of the front-panel screwdriver controls until after the instrument warms up (at least 20 minutes).

Rotate the SCALE control clockwise and check that the graticule illuminates.

3. Obtain Display

Adjust the INTENS and FOCUS controls for the desired brightness and a well-defined vector display. Use the PHASE control to place the vector tips and burst on their targets. See Figure 2-4.

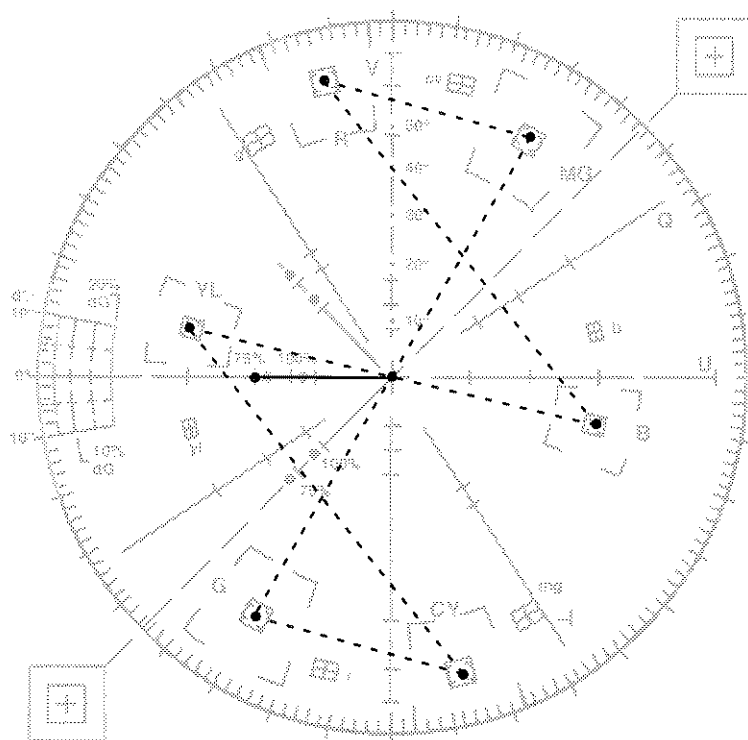

Figure 2-4: Typical 1725 vector display

Adjust the SCALE illumination control for the desired brightness. Note that the internal waveform graticule is illuminated along with the marker in NTSC graticule target and the NTSC LED indicator.

4. Select Input

Select the Channel B input for a display of the modulated staircase signal. See Figure 2-5. Check that the PAL indicator and graticule marker are both correct.

Rotate the PHASE control until the bursts are about 180° from their targets. Push the AUTO (PHASE) push button and check that the burst vector tips return to their targets.

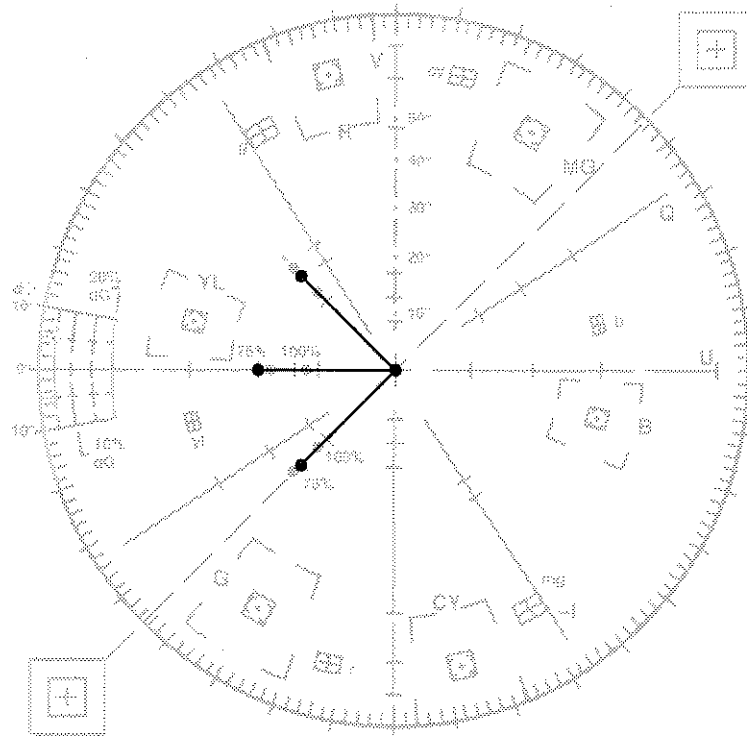

Figure 2-5: Modulated staircase waveform shown on a 1725

Briefly push the INPUT button and check that the CH-A indicator and the NTSC LED are lighted and that only a vector display is present.

5. Select Reference

Push the INPUT to switch to CH-B and the REF button and check that the front-panel EXT indicator lights. Check for a stable PAL modulated staircase display (CH-B INPUT).

Push the INPUT switch for a CH-A NTSC signal.

Push and hold the REF button until the front-panel TEST indicator lights. Check for a test circle display. See Figure 2-6.

Leave the 1725 REF in TEST.

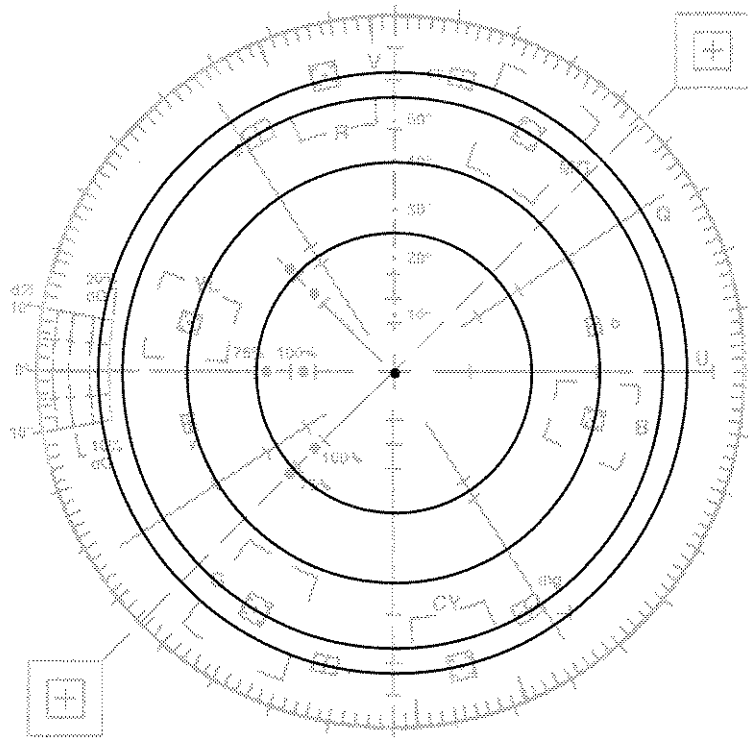

Figure 2-6: 1725 test circle display

6. Position Center Dot

Use a small screwdriver to adjust the VERTICAL and HORIZONTAL POSITIONING controls. Check that there is sufficient range to move the dot through the geographic center of the display (the graticule center target). It should be noted that the amount of adjustment range varies from instrument to instrument.

Adjust the positioning controls to place the center dot at the exact center of the graticule.

7. Set Gain

With the test circle displayed, use a screwdriver to adjust the GAIN CAL fully clockwise and check that the outer circle is outside of the outer (Red and Cyan) graticule targets.

Set the GAIN CAL fully counterclockwise and check that the outer circle is inside of the outer (Red or Cyan) graticule targets.

Set the GAIN CAL so that the outer circle passes through the outer (Red and Cyan) graticule targets.

8. Variable

With the test circle displayed, push the VARIABLE push button and check that the VARIABLE ON indicator lights.

Rotate the VARIABLE control clockwise and check that the display increases in size.

Rotate the VARIABLE control counterclockwise and check that the outer circle is inside the outer (Red and Cyan) targets.

Push the VARIABLE push button and check that the test circle is on the outer targets and that the front-panel VARIABLE ON indicator is turned off.

9. Check the Rotation of the Display

Variations in the earth's magnetic field may make adjustment of the ROTATE control necessary at installation time or whenever the instrument is moved.

Connect the audio signal, through the XY INPUT connector on the rear panel, to the +X input (pin 3). Set the 1725 MODE to XY. Set up the audio signal amplitude for a horizontal trace that is long enough to reach across the graticule compass rose.

Check that the sweep is a straight line parallel to the horizontal axis. If not, adjust the ROTATE adjustment until the sweep is parallel to the horizontal axis.

10. Check XY Mode

Connect the audio signal to both pins 3 and 7 of the rear-panel XY INPUT. Set the 1725 MODE to XY. Adjust the audio signal amplitude to place the diagonal trace on the 45° graticule line. Adjust audio signal amplitude so that the ends of the trace fall on the target (+) marks.

11. Check Dual Mode

Select INPUT A. With the color bar composite video signal connected to the CH-A INPUT and the audio signal connected to the XY INPUT (pins 3 and 7) push and hold the MODE push button until both VECT and XY are lighted. Check for a display of both vectors and the XY lissajous pattern.

Measurement Graticule

The 1725 graticule is unique in that it contains burst and vector targets for both PAL and NTSC color standards. The internal vector graticule has targets for

both NTSC and PAL (with or without setup) color signals that are scaled for both 75% and 100% amplitude color bars. See Figure 2-7. Variable graticule scale illumination provides even lighting over the usable graticule area to improve measurement accuracy and the quality of waveform photographs.

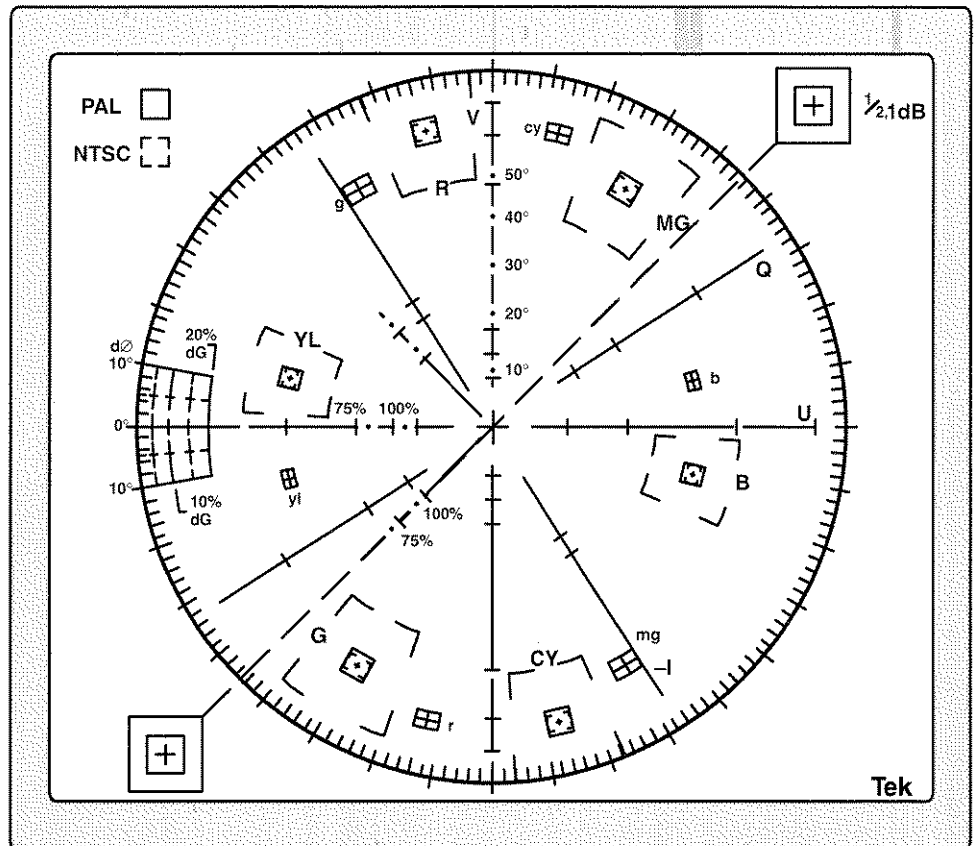

Figure 2-7: 1725 PAL/NTSC Vectorscope graticule

The NTSC and +V axis PAL vectors share targets. The tolerance for inner NTSC targets is tighter than the PAL tolerances, resulting in two targets in the smaller boxes. The smallest targets are for NTSC vectors.

Measurement Applications

The 1725 is a vectorscope capable of making both chrominance and XY measurements. The information that follows is intended to guide both new and experienced users through simple and complex measurement techniques. The information is divided by major topics, which are then subdivided into specific measurements.

Color Measurements

In color television, the visual sensation of color is described in terms of three qualities: luminance, hue, and saturation.

Luminance. Luminance is brightness as perceived by the eye. As the eye is most sensitive to green and least to blue light of equal energy, green is a bright color and blue is a dark color as conveyed by the luminance signal to monochrome TV receivers.

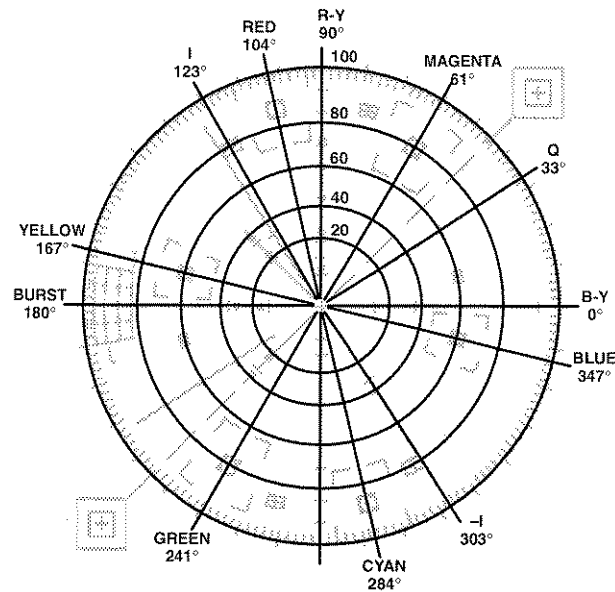

Figure 2-8: NTSC standard color phase Vector diagram

Chrominance. Chrominance is measured in terms of hue and amplitude. Hue is the attribute of color perception that determines whether the color is red, blue, green, etc. White, black, and gray are not considered hues. Hue is presented on the vectorscope crt as a phase angle and not in terms of wavelength. For example, red, having a wavelength of 610 millimicrons, is indicated as 104° on the standard color phase vector diagram when the burst is at 180° for NTSC or 135° for PAL. The standard color phase vector diagram is shown in Figure 2-8 for NTSC and Figure 2-9 for PAL.

Saturation is the degree to which a color (or hue) is diluted by white light in order to distinguish between vivid and weak shades of the same hue. For example, vivid red is highly saturated and pastel red has little saturation. Because saturation is a product of both luminance and chrominance amplitudes, and a vectorscope can only measure chrominance amplitude, the radial distance from the center to the end of the color vector is chrominance amplitude. If burst vector amplitude corresponds to the 75% amplitude marking (see Figure 2-10),

the colors represented by the vectors when they are within the targets are of 75% amplitude.

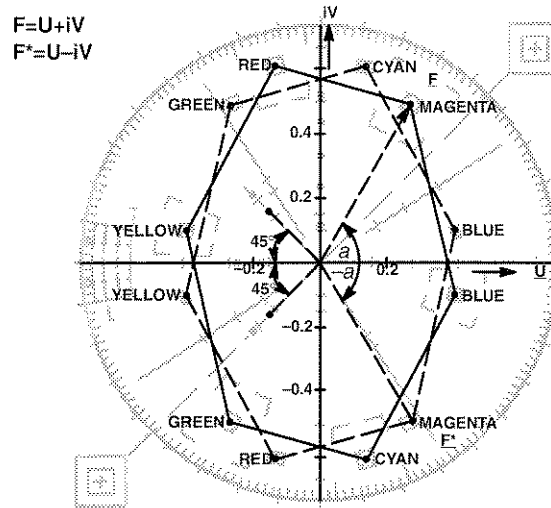

Figure 2-9: PAL standard color phase Vector target

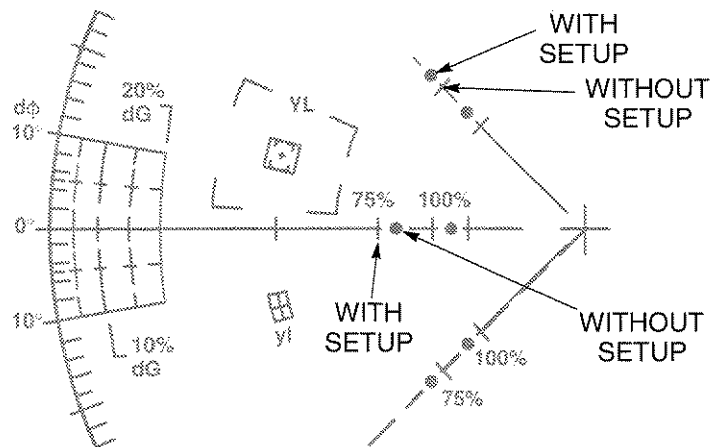

Figure 2-10: NTSC and PAL 75% and 100% burst targets on 1725 graticule

If burst vector amplitude corresponds to the 100% marking and the chrominance vectors are within the target, the color amplitude is 100%.

Encoding. The hue and color amplitude information in the color television system is carried on a single subcarrier frequency: 3.579545 MHz for NTSC and 4.43361875 MHz for PAL. These signals, in modulated subcarrier form, are called chrominance. The hue information is carried by the subcarrier phase; the

color amplitude information is carried by means of amplitude modulation with the subcarrier suppressed. A subcarrier which supplies phase information is required for demodulation. No picture chrominance signals are present during the horizontal blanking interval and a sample of the subcarrier, used by decoders for a reference (called burst), is provided within this interval.

Decoding. To recover the hue information, phase demodulators are employed in the vectorscope. The phase reference is the color subcarrier, which is regenerated by an oscillator in the instrument. The oscillator is locked in both phase and frequency to the incoming color burst signal on the horizontal (line) sync back porch. The vectorscope displays the relative phase and amplitude of the chrominance signal on polar coordinates. To identify these coordinates, the vector graticule (see Figure 2-8 for NTSC and Figure 2-9 for PAL) has points that correspond to the proper phase and amplitude of the three primary colors and their complements, which are related to the 180° burst vector for NTSC and the 135° burst vector for PAL. The coordinates for the primary colors (red, blue, and green) and their complements (cyan, yellow, and magenta), when the burst vector is at 225° for PAL, are identified with lowercase abbreviations.

Any errors in the color encoding, video tape recording, or transmission processes which change these phase or amplitude relationships causes color errors on the television receiver picture. The polar-coordinate-type of display, such as that obtained on the 1725, has proven to be the best method for portraying these errors.

Functional Use of the Vector Graticule

Measurement of Color Bars

The polar display permits measurements of hue in terms of the relative phase of the chrominance signal with respect to the color burst. Relative amplitude of chrominance to burst is expressed in terms of the displacement from center (radial dimension of amplitude) towards the color point which corresponds to 75% (or 100%) amplitude for the color being measured.

On the 1725 graticule, each NTSC chrominance vector terminates in a system of graticule targets in the form of two boxes (a small box inside a large box). See Figure 2-11. The dimensions of the large boxes represent $\pm 10^\circ$ centered on the exact chrominance phase, and $\pm 20\%$ of chrominance amplitude centered around 100% of standard amplitude. The dimensions of the smaller boxes represent $\pm 2.5^\circ$ and ± 2.5 IRE.

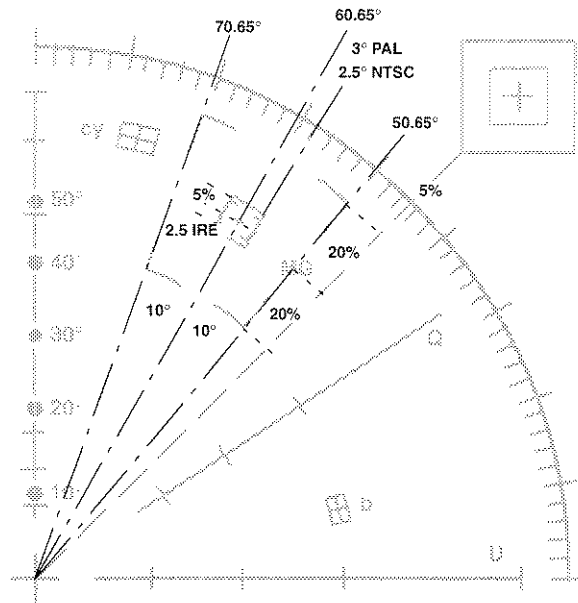

Figure 2-11: Fine detail of the 1725 graticule magenta target

On the 1725 graticule, each PAL chrominance vector related to the +V burst terminates in targets that are in the shape of two boxes (a small box inside a large box). See Figure 2-11. The large box represents $\pm 10^\circ$ centered on the exact chrominance phase and $\pm 20\%$ of chrominance amplitude centered around 100% standard amplitude. The dimensions of the inner target represent $\pm 3^\circ$ and $\pm 5\%$ of chrominance amplitude; the vectors associated with the -V burst terminate in the smaller targets.

The 1725 has small marks at intervals along the I and Q axes that denote the amplitudes of the chrominance components (see Figure 2-12). The small marks at intervals along the U and V axes denote the amplitudes of the U and V chrominance components (see Figure 2-13).

The horizontal and vertical axes of the vector graticule contain markings for checking bandwidth. A subcarrier frequency sine wave whose amplitude places it on the outer compass rose is used as a reference. When the frequency is changed the diameter of the circle should reduce. At a point equal to 70% of full amplitude (3 dB), there are gaps in the horizontal and vertical axes. This calibration aid makes it possible to check the -3 dB points of the demodulator output amplifiers.

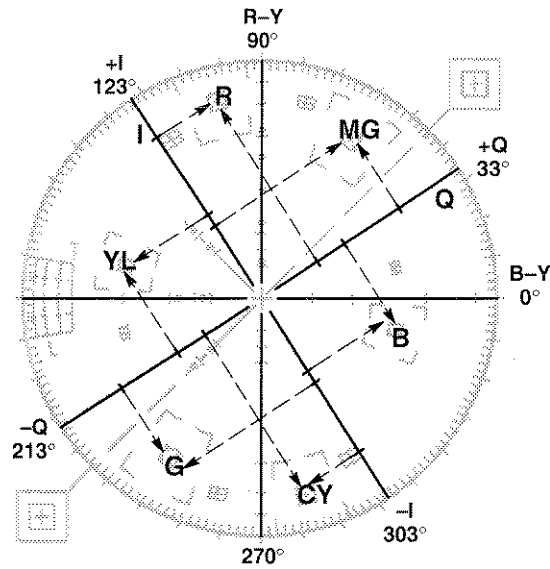

Figure 2-12: Relationship of I and Q modulation amplitudes to vector targets

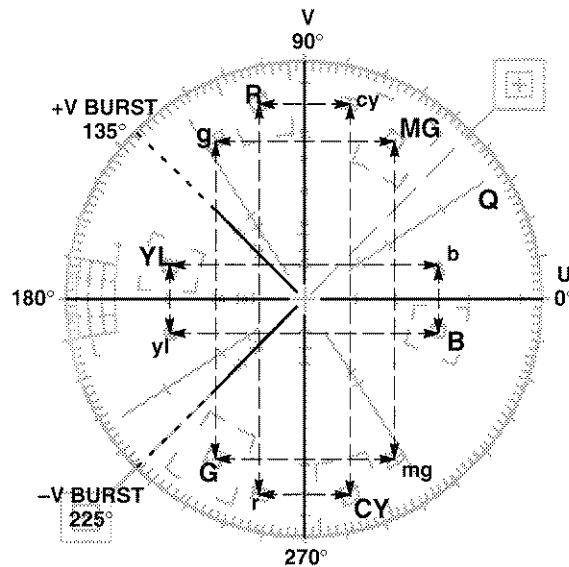

Figure 2-13: Relationship of U and V modulation amplitudes to vector targets

Differential Gain and Phase Measurements

The two major system distortions that affect the color signal are differential gain and differential phase. They are chrominance nonlinearities caused by luminance amplitude variations. Both can be measured on the vectorscope. Differential gain is a change in color subcarrier amplitude due to a change in the luminance signal while the hue of the original signal is held constant. In the reproduced picture, saturation will be distorted in the areas between the light and dark

portions of the scene. Differential phase is a phase change of the chrominance signal, caused by a change in the luminance signal, while the original chrominance signal amplitude is held constant. In the reproduced picture, the hue will vary with the scene brightness. Differential gain and differential phase may occur separately or together.

Differential gain (dG) and differential phase ($d\phi$) measurements can be made using the graticule markings located at the outer edge of the B-Y and U axis. See Figure 2-14 for differential gain and phase measurement illustration.

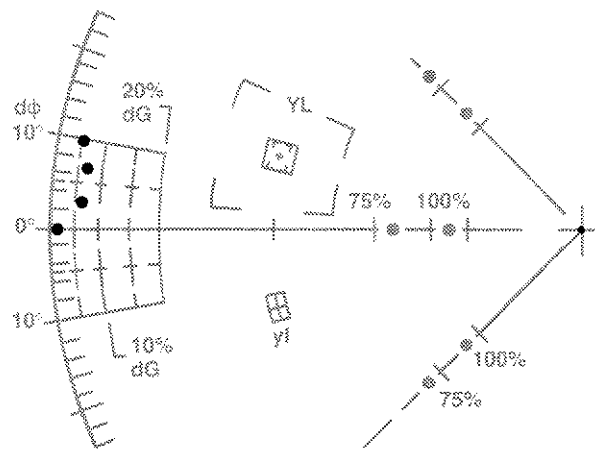

Figure 2-14: Differential phase and gain scales showing simulated 10° differential phase ($d\phi$)

High Resolution Differential Phase Measurement — The DEMOD OUT from the 1725 can be used to drive one of the inputs to a 1730-Series Waveform Monitor for improved measurement resolution. This measurement requires a modulated ramp or staircase signal with the 1725 gain normalized so the chrominance amplitude is on the compass rose.

The 1730-Series must have the DC REST OFF and the VERTICAL GAIN at X5. Once these conditions are set up, using 1 LINE SWEEP makes each major vertical division of the 1730-Series graticule equal to 2°, when referenced to the sweep origin.

Matching Color Signals

When the 1725 is in the dual phase shifter mode (see Installation, Section 3, for more information), it is possible to match vector phase and amplitude to a degree of accuracy far greater than previously attainable. By inputting a known signal into CH B and the signal to be matched to it into CH A, the signal on CH A can easily be adjusted for an exact match. The digital phase shifter can be assigned to either channel, as desired, by simply touching the INPUT switch for the desired input signal.

When this type of color signal matching is employed, all variations due to crt geometry, graticule resolution, quad phase errors, and differential gain and phase are effectively eliminated.

Applying the output of a programmable signal generator, such as the Tektronix TSG 1001, as the reference allows creation of a defacto custom graticule. When the signal input through CH A matches or approximates the displayed reference from CH B there is no need to display against a graticule scale.

Looking at Incidental Carrier Phase Modulation

The High-Gain X and Y inputs of the 1725 can be used to look at ICPM (Incidental Carrier Phase Modulation). ICPM is a change in carrier phase with a signal level change. It will show up as apparent differences between measurements made in synchronous and envelope detection modes. On home receivers with envelope detectors, the picture will be unaffected if the visual transmitter has been adjusted using envelope detection when there is appreciable ICPM. However, ICPM can show up in the home receivers audio as intercarrier buzz.

ICPM can be looked at by applying the Video and Quadrature Outputs from a demodulator to the 1725 X and Y Inputs. The Quadrature Output drives the High-Gain X Input and the Video Output drives the High-Gain Y Input. The resulting display will be vertical when ICPM is minimum, and tilted when ICPM is present.



CAUTION. *This is not a definitive measurement, but does provide a way of determining if ICPM is present in the signal.*

XY Measurements

Any oscilloscope, including vectorscopes that have identical X and Y amplifiers, can be used to make accurate stereo audio phase measurements. When identical signals of equal amplitude are input, the resultant display will be a lissajous pattern, whose opening is relative to the phase error between the signals. If there is no phase error between signals, the display will be a diagonal line, at a 45° angle. When the signals are not equal in phase, the pattern will have its axis on the diagonal but be displayed as an ellipse. As long as the amplitude of the signals remains the same, the amount of opening in the ellipse (up to 90°) is a relative measure of the phase difference. At 90° the display is a circle; errors greater than 90° cause the axis to rotate by 90°.

Making Stereo Audio Phase Measurements

The graticule for the 1725 has scales for measurement of stereo audio phase. The dashed diagonal line is the measurement axis for errors less than 90°, it is terminated in amplitude targets that correspond to the length of X and Y axes.

The boxes, surrounding the cross hairs, are equal to amplitude errors of 1/2 and 1 dB, respectively. See Figure 2-15.

The upper half of the Y axis has markings, in 10° increments, for measurement of the elliptical waveform that occurs when there is a phase error. Both the X and Y axes have -3 dB markings making it easy to check the bandpass of the amplifiers. The 3 dB points are minor breaks in the line about 30% of the distance from the graticule circle to the graticule center.

In order to make this type of measurement it is essential that the input signal amplitudes be equalized. This is easily accomplished by applying only one signal at a time and adjusting its gain to correspond to the appropriate axis (horizontal to the X axis and vertical to the Y axis).

Once both signal gains are normalized they can be displayed in the XY Mode and the relative stereo phase measured. See Figure 2-15.

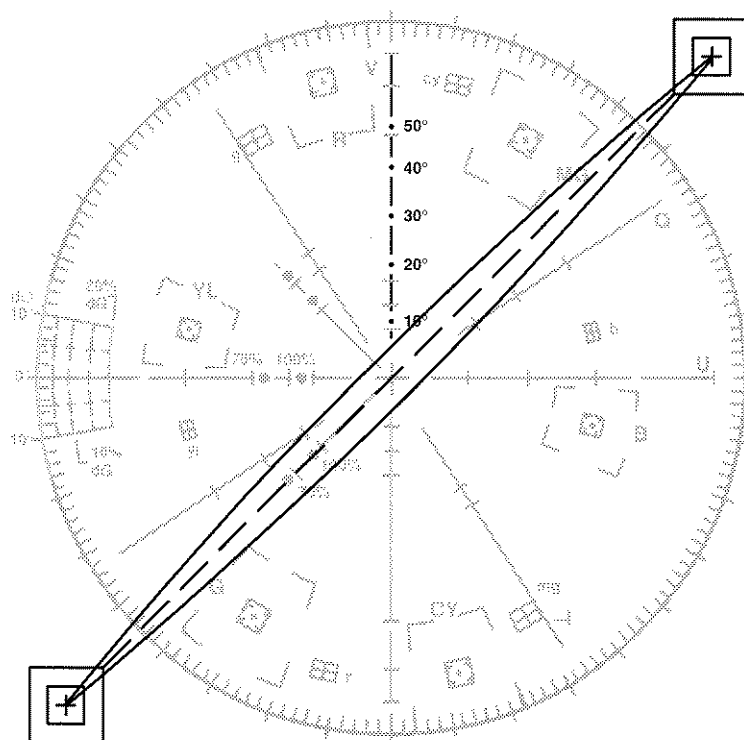

Figure 2-15: Measuring stereo audio phase difference in X and Y axes

Warning

The following servicing instructions are for use only by qualified personnel. To avoid personal injury, do not perform any servicing other than that contained in the operating instructions unless you are qualified to do so. Refer to General Safety Summary and Service Safety Summary prior to performing any service.

Servicing Safety Summary

FOR QUALIFIED SERVICE PERSONNEL ONLY
Refer also to the preceding Operators Safety Summary

Do not service alone

Do not service or adjust this product unless another person capable of rendering first aid and cardio-pulmonary resuscitation is present.

Use care when servicing with power on

Dangerous voltages exist at several points in this product. To avoid personal injury, do not touch exposed connections and components while power is on.

Disconnect power before removing protective panels, soldering, or replacing components.

Power source

This product is intended to operate from a power source that applies no more than 250 volts RMS between the supply conductors or between either supply conductor and ground.

Ground the product

This product is grounded through the grounding conductor of the power module power cord. To avoid electrical shock, plug the power cord into a properly wired receptacle before connecting to the product input or output terminals. A protective ground connection by way of the grounding conductor in the power cord is essential for safe operation.

Section 3

Installation

Packaging The shipping carton and pads provide protection for the instrument during transit; they should be retained in case subsequent shipment becomes necessary. Repackaging instructions can be found in Section 6 (Maintenance) of this manual.

Electrical Installation

Power Source This instrument is intended to operate from a single-phase power source with one current-carrying conductor at or near earth-ground (the neutral conductor). Only the Line conductor is fused for over-current protection. Systems that have both current-carrying conductors live with respect to ground (such as phase-to-phase in multiphase systems) are not recommended as power sources.

Mains Frequency and Voltage Ranges The 1725 Vectorscope operates over a frequency range of 48 to 66 Hz, at any mains voltage between 90 Vac and 250 Vac. These newer versions of the 1730-Series instruments *do not* require any internal changes to select their operating voltage range.

Operating Options

Not all installations are identical. In order to make operation of the 1725 Vectorscope as flexible as possible there are internal jumpers that can be changed to provide operating flexibility. For example, it is possible to select CW Subcarrier for EXT REF instead of Composite Video or Black Burst. The factory preset position is indicated by a box printed on the etched circuit board. Table 3-1 details these internal jumper selections. Be sure that all operators are aware of changes, to prevent unnecessary trouble reports, if any of these jumpers are placed in the optional position. See Figure 3-1 for locations of the internal Main board jumpers.

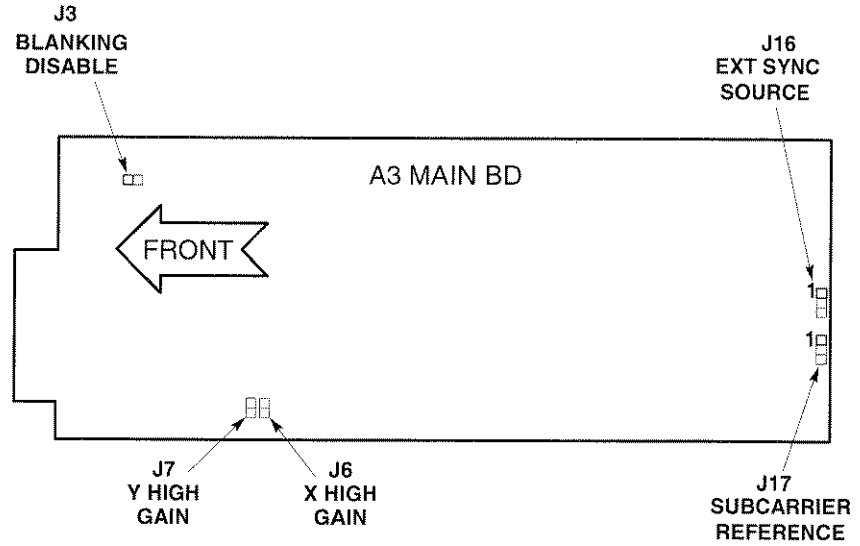

Figure 3-1: Jumper locations on the Main board

Table 3-1: Internal Jumper Selection

Jumper #	Name	Position	Purpose
A3J16	External Sync Source (EXT REF Input)	1-2	EXT REF (factory preset)
	Converted to CW Subcarrier Input	2-3	CH-A INPUT
A3J17	Subcarrier Reference	1-2	EXT REF (factory preset)
		2-3	CW Subcarrier applied to EXT REF INPUT
A3J3	Blanking Disable	Out	Normal Blanking (factory preset)
		In	CRT Blanking disabled
A3J7	Y Input High Gain	Out	Balanced 600Ω input (factory preset)
		In	Single-ended high gain mode
A3J6	X Input High Gain	Out	Balanced 600Ω input (factory preset)
		In	Single-ended high gain mode

Table 3-1: Internal Jumper Selection (Cont.)

Jumper #	Name	Position	Purpose
A3A1 J100	Light Enable	1-2	Lights Enabled (factory preset)
		2-3	Lights Disabled
A4J100	Phase Control	1-2	Tracks Channel Selection (factory preset)
		2-3	Dual Phase Shifter

XY INPUT Connector

The rear-panel XY INPUT connector is a 15-pin, sub-miniature, D-type connector that provides input to the Horizontal and Vertical (X and Y) Amplifiers. They are balanced (differential), dc-coupled, high impedance (>20 kΩ), un-terminated inputs provided for audio applications. If ac coupling is desired, external capacitors are required. These inputs are factory calibrated for 0 dBm in 600Ω but can be adjusted for any 600Ω system between 0 and 12 dBm. See Figure3-2.

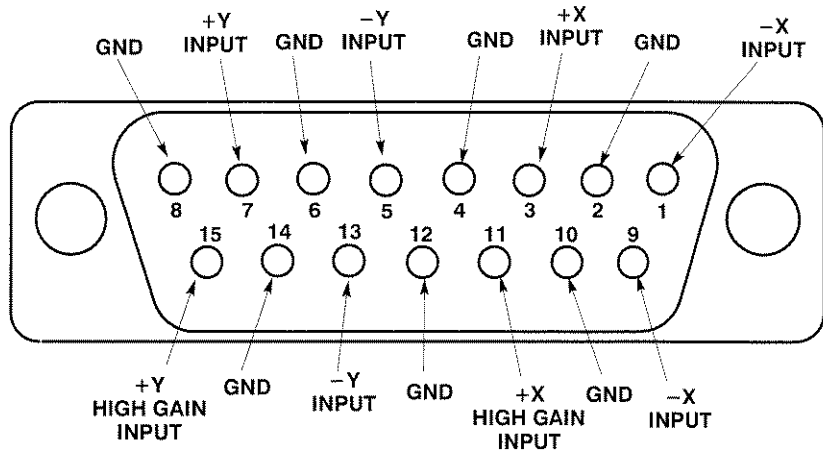

Figure 3-2: REMOTE connector pin functions

0 dBm is equal to 1 mW or 2.19 V peak-to-peak in 600Ω.

12 dBm is equal to 15.8 mW or 8.72 V peak-to-peak in 600Ω.

Inputs can be driven single-ended by driving either of the + X and Y inputs with the minus polarity inputs grounded.

In addition, a single-ended, high-gain mode can be used for other, primarily non-audio, applications. It can be accessed by installing plug jumpers on A3J6 and A3J7 (on the Main board) and inputting the signal on the +X and +Y inputs with the -X and -Y inputs grounded.

AUXILIARY Connector

The rear-panel AUXILIARY connector is a 9-pin, D-type connector. It is used to control the display from a companion 1730-Series Waveform Monitor. Line and Field selection information is provided to the vectorscope over the bus that is contained in this interface. Figure 3-3 and Table 3-2 show the AUXILIARY connector pin assignments.

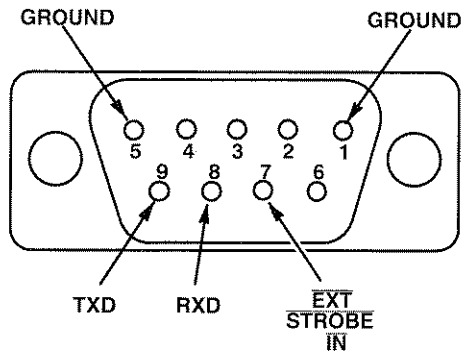

Figure 3-3: AUXILIARY connector pin functions

Table 3-2: AUXILIARY Connector Pin Assignments

Pin #	Use
1, 3, 4, & 5	Ground
7	External Strobe In for Line Select blanking.
8	RXD (Receive Data) 1730-Series communication to the 1725.
9	TXD (Transmit Data) 1725 return communication to 1730-Series.

Mechanical Installation

Cabinetizing

All qualification testing for the 1725 was performed in a 1700F00 cabinet. To guarantee compliance with specifications, the instrument should be operated in a cabinet. The plain cabinet, 1700F00, is shown in Figure 3-4.

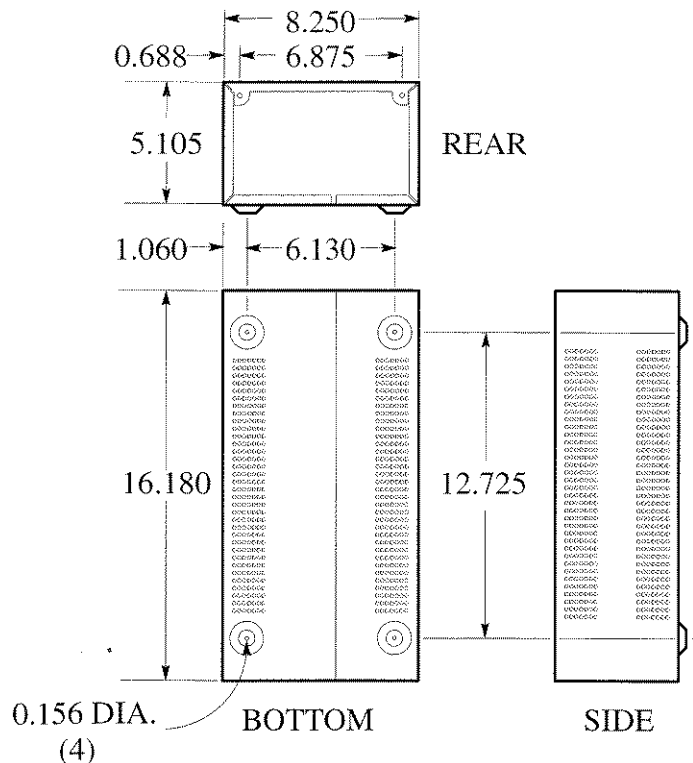

Figure 3-4: Dimensions of the 1700F00 plain cabinet.

The portable cabinet, 1700F02, is shown in Figure 3-5. The 1700F02 has a handle, four feet, a flip-up stand, and a front cover. This F02 cabinet is compatible with the TEKTRONIX BP1 battery pack, which can be used as a dc power source. The hole sizes and spacing are different from those of the 1700F00.

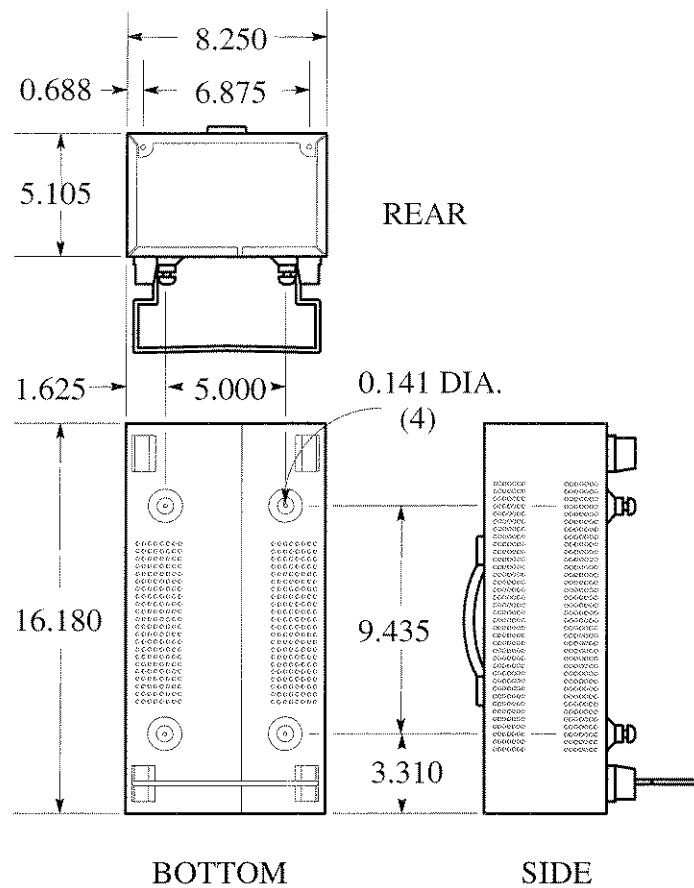

Figure 3-5: 1700F02 portable cabinet

All of the 1700-Series metal cabinets, which are available from Tektronix as Optional Accessories, provide the proper electrical environment for the instrument. They supply adequate shielding, minimize handling damage, and reduce dust accumulation within the instrument.

Securing the Instrument in its Cabinet



WARNING. Do not attempt to carry a cabinetized instrument without installing the mounting screws. Without the mounting screws there is nothing to hold the instrument in the cabinet if it is tipped forward.

The instrument is secured to the cabinet by two 6-32 Pozidrive® screws, located in the upper corners of the rear panel. See Figure 3-6.

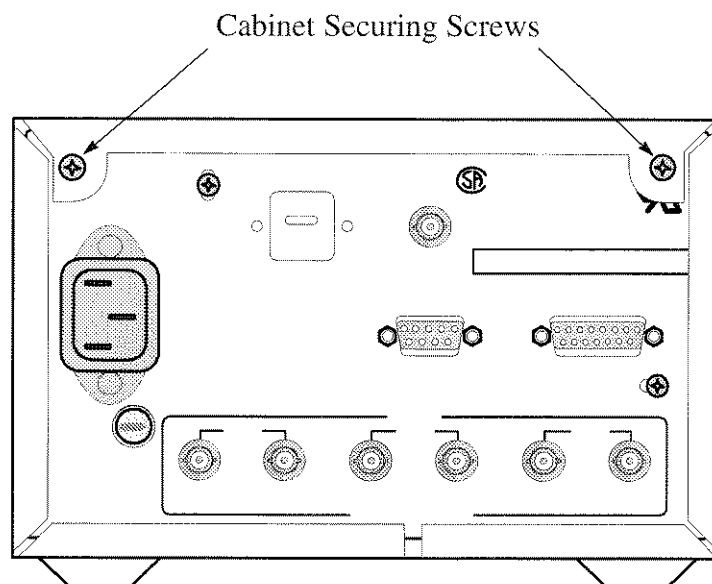

Figure 3-6: Rear view of the instrument, shown in the cabinet, with the securing screws identified

Rack Mounting

The optional 1700F05 side-by-side rack adapter, shown in Figure 3-7, consists of two attached cabinets. It can be used to mount the 1725 and another half-rack width instrument in a standard 19-inch rack.

The rack adapter is adjustable, so the 1725 can be more closely aligned with other equipment in the rack. See Figure 3-7.

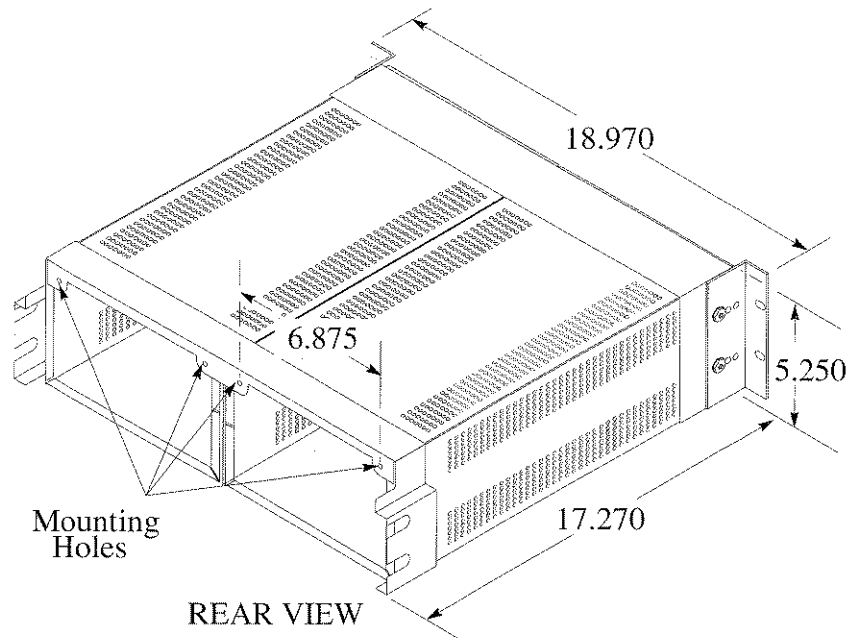

Figure 3-7: The 1700F05 side-by-side rack adapter

If only one section of the rack adapter is used, a 1700F06 Blank Panel can be inserted in the unused section. See Figure 3-8. The rack adapter and panel are available through your local Tektronix field office or representative.

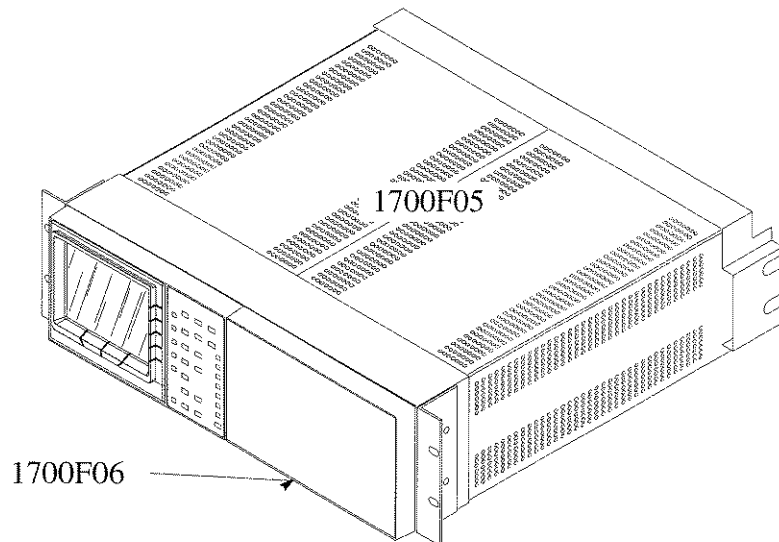

Figure 3-8: A 1700-Series instrument mounted in a 1700F05 cabinet with a blank front panel (1700F06) covering the unused side of the cabinet

In addition to being able to fill the unused side of the side-by-side rack mount cabinet (1700F05) with a blank front panel, an accessory drawer (1700F07) can be installed in the blank side of the cabinet. See Figure 3-9.

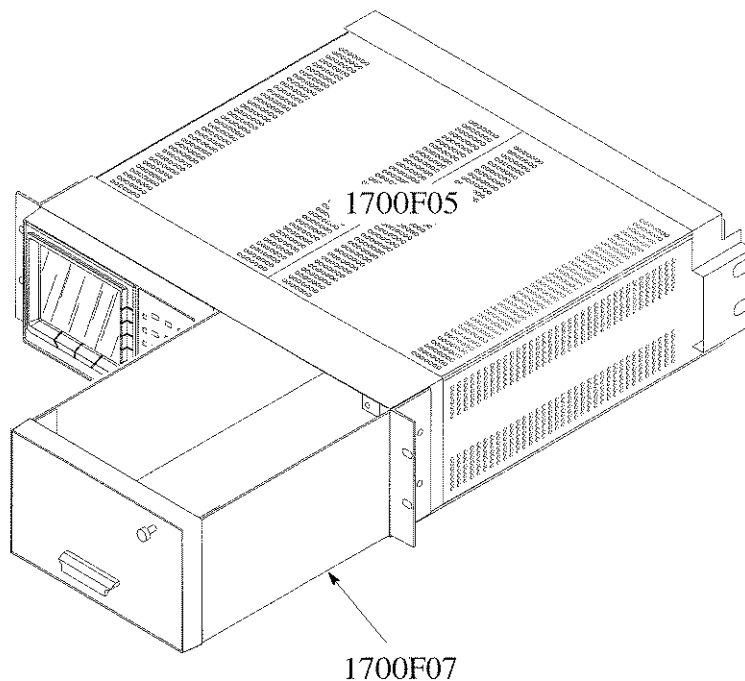

Figure 3-9: A 1700F05 side-by-side rack mounting cabinet with an instrument and a 1700F07 utility drawer

Custom Installation

For applications such as consoles, shown in Figure 3-10, the instrument can be mounted with front molding flush or protruding from the console. In both cases, allow approximately 3 inches of rear clearance for BNC and power cord connections.

To mount the 1725 safely, attach it to a shelf strong enough to hold its weight. Install the mounting screws through the four 0.156-inch diameter holes in the bottom of the 1700F00 cabinet. See Figure 3-10.

For Flush Front Panel: Cut hole the same size as the monitor front molding to allow the monitor front panel to align with the custom panel surface.

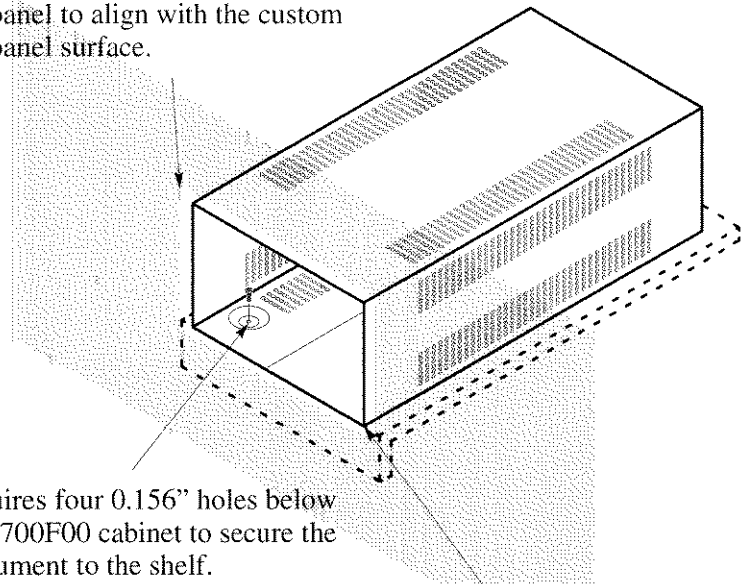

Requires four 0.156" holes below the 1700F00 cabinet to secure the instrument to the shelf.

For Protruding Front Molding: Cut hole in panel the same size as the opening in the monitor cabinet to allow the front-panel molding to cover the hole.

Figure 3-10: Considerations for custom installation of an instrument

Section 4

Theory of Operation

The material in this section is subdivided into general description, which is supported by the main block diagram and simplified block diagrams, and detailed circuit descriptions that use the schematic diagrams as illustrations. A thorough understanding of the instrument starts with a knowledge of how the major circuit blocks fit together, followed by individual circuit operation.

Overview

The simplified block diagram shown in Figure 4–1 and the following paragraphs are intended to introduce the 1725 Vectorscope in the broadest of terms. A full scale discussion of operation follows this overview.

The 1725 is a special purpose oscilloscope, designed to display the variations of phase in the NTSC or PAL color television signal. Color signals, input through the rear-panel bridging loopthrough connectors, are displayed on the crt in a Cartesian plot. An added feature makes it possible to compare two-channel audio signals. Audio signals are brought in through the rear-panel XY INPUT connector for an XY display of phases used for stereo encoding of the audio signal.

Front-panel mode switching is accomplished by push-button switches whose status is being constantly polled by a microprocessor. The microprocessor controls gains and switching functions to make specific measurements.

The composite video signal from either the Channel A or B input is first separated into its chrominance and luminance components. The luminance component is used to generate the clamp signals used in the display of the chrominance information and for synchronizing vectorscope operation. The gain of the chrominance signal is adjusted prior to input to the Demodulators, for quadrature demodulation. The demodulated output is filtered and clamped (at H-Sync rate) by clamped amplifiers. The Output Amplifiers match signal impedance and drive the crt deflection plates.

In addition to being demodulated and displayed, the chrominance signal can be used to provide the internal subcarrier sample (in the INT REF position) to the Subcarrier Regenerator. External Reference, when selected, is through the rear-panel bridging loopthrough EXT REF Input. The regenerated subcarrier can be phase shifted, by up to 360°, using the front-panel PHASE control. For PAL applications, a 180° flip-flop is employed to reverse the phase of every other line so that the +V and –V signals can be overlaid for phase matching applications.

The regenerated subcarrier, used for demodulation, is applied directly to the B-Y (U) Demodulator and delayed by 90° (quadrature phased) for the R-Y (V) Demodulator.

The B-Y (U) Demodulator drives the Horizontal Output Amplifier; the R-Y (V) Demodulator drives the Vertical Output Amplifier.

The rear-panel X Y INPUT connector provides an input for audio signals, which can be displayed as XY signals for stereo comparisons. Identical amplifiers provide high input impedance and drive the Vertical and Horizontal Output Amplifiers.

If there is no signal, the Center Dot Blanking circuit blanks the crt to prevent it from being damaged by the non-deflected center dot.

BLOCK DIAGRAM

This description uses the 1725 Block Diagram, which is located at the beginning of the Diagram section (Section 9). The diagram can be folded out and viewed while reading this description.

Video Input

Video signals are applied through identical input amplifiers to normalize gain and provide impedance matching. An external reference can be used for both luminance- and chrominance-related functions. If composite video or black burst is used for the External Reference, no additional processing is required. When CW Subcarrier is used, the luminance reference is taken from the video input and the chrominance reference is attenuated from the subcarrier input, through the External Reference.

Luminance Processing

The sync signals used by the vectorscope are contained in the luminance information from the video inputs. The composite video signal through the Luminance Amplifier drives a sync separator, whose output is used to drive a Bowes Oscillator that regenerates H Sync. The H Sync also generates Sample Pulses and the Clamp signals, that activate the Burst Switches, and provide the line rate control signal for the V Axis Switcher.

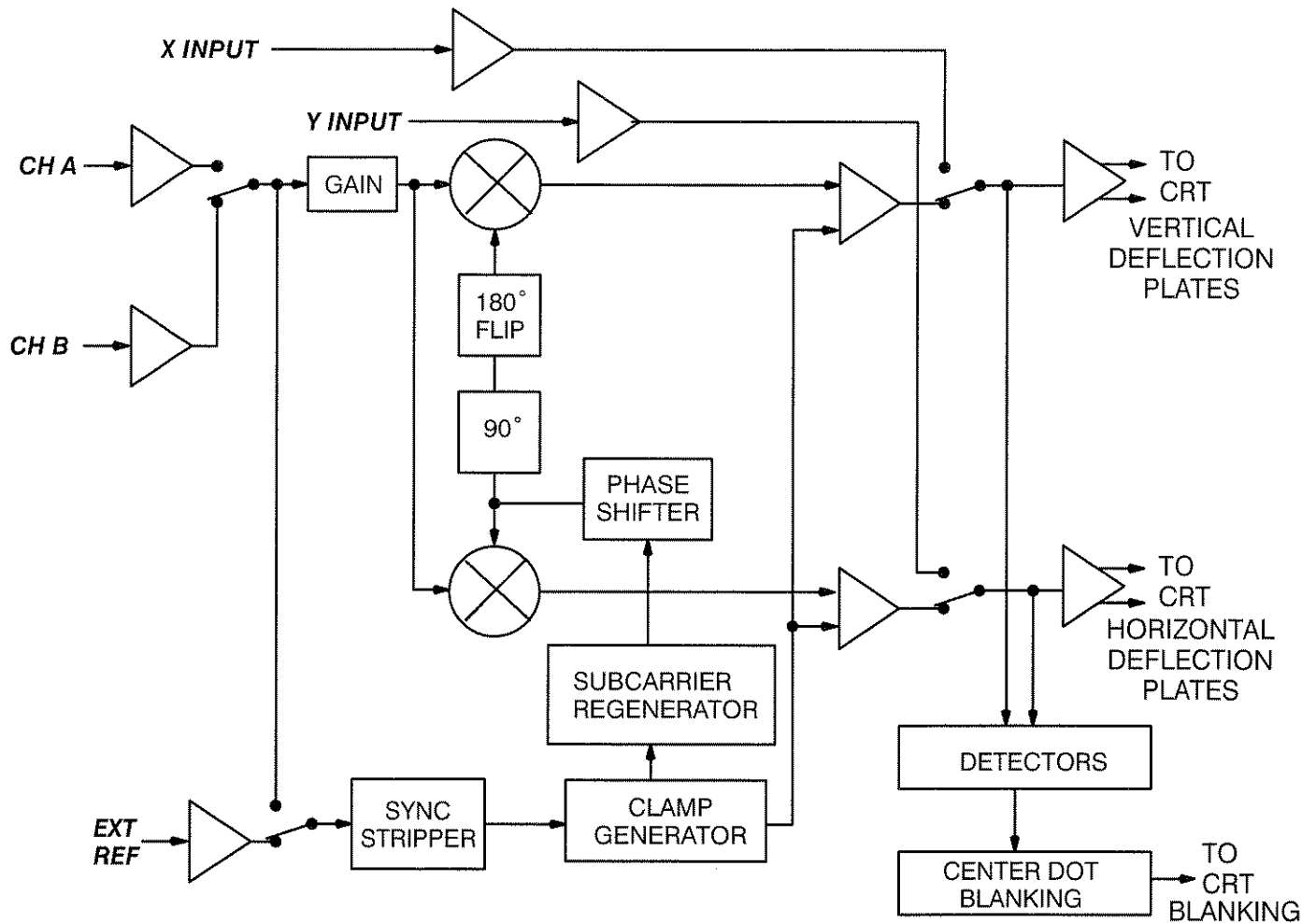

Figure 4-1: Simple block diagram of a vectorscope

Microcontroller

The microprocessor polls the front panel to determine changes in status. Current status is stored in Nonvolatile Random Access Memory (NOVRAM), which makes it possible to return to the same front-panel condition should power be interrupted. If the 1725 is being used as an auxiliary instrument to a 1730-Series Waveform Monitor, any stored vectorscope front-panel setup data is also in the NOVRAM. Based on the front-panel conditions, the microcontroller generates controlling signals that are used throughout the 1725. The front-panel indicators are driven by the microcontroller so that they will mirror the current measurement criteria.

Gain Cell

The gain cell uses front-panel VAR GAIN and GAIN CAL settings and switching signals from the microcontroller to adjust the chrominance gain prior

to demodulation. Gain cell chrominance is clamped to ground at sync tip time for a stable reference level.

Chrominance Processing

Chrominance from the incoming video signal, either internal or from the External Reference, is conditioned by the Chrominance Amplifier and applied to the Phase Detector at burst time (Burst Gate signal). The chrominance input to the Lock Detector is delayed by 90° . The chrominance signal is compared to the regenerated subcarrier from the VCXO with the output low-pass filtered and buffered. The Phase Detector is clamped and supplied to the Error Amplifier, which provides an output voltage to correct the VCXO should it be off frequency.

The output of the Lock Detector compares the burst chrominance to 90° phase-shifted subcarrier, with the output low-pass filtered and buffered. The resulting signal is a pulse, when burst is present, that clamps the Phase Detector output. It is also checked for phase lock and, if unlocked, an output is supplied to the Error Amplifier to increase its bandwidth for a faster locking. When the TEST (Cal Mode) is enabled, the Error Amplifier is forced into an unlocked state to provide the test circles.

The regenerated and quadrature phase delayed subcarrier from the VCXO can be phase shifted up to 360° by a digital phase shifter (front-panel PHASE control) whose output is buffered prior to input to the demodulators.

Sampled output from the R-Y and B-Y and H sync are checked for coincidence, producing an "In Window" signal, which is fed back to the microcontroller to establish when burst is correctly placed.

The V Axis Switcher controls the PAL F_{SC} signal to the carrier input of the R-Y Demodulator to ensure the correct phase on alternate lines. When +V display, in PAL, is selected the switcher clamps one R-Y Demodulator input to ground to disable alternate line switching of subcarrier.

Demodulators

The 1725 employs quadrature demodulation, which consists of delaying the regenerated subcarrier by 90° to the R-Y (V) Demodulator. For PAL signals, an additional 180° phase shift is achieved by switching the regenerated subcarrier to the -input of the demodulator. The incoming chrominance is compared to the regenerated subcarrier and the output is low-pass filtered and amplified. Center Dot clamping is used to keep the effects of chrominance from distorting the display center dot.

Output Amplifiers

The Vertical and Horizontal Deflection Amplifiers do double duty. They are used to output both the vector display and the XY display. The input of the amplifiers is checked for the presence of a signal over a certain amplitude, and the resulting output is one input to the CRT Blanking circuit. X and Y signals are input through

balanced amplifiers which can be converted to single-ended high gain inputs. Input switching is controlled by the microcontroller and front-panel switching.

CRT Blanking CRT blanking takes inputs from the front-panel INTENSITY control, the microcontroller, and the Center Dot Comparators to generate the blanking signal. In addition, in the Auxiliary mode of operation, a line select strobe from a companion 1730-Series can drive the blanking amplifier to unblank only the line or lines that are selected with the waveform monitor's line selector.

CIRCUIT DESCRIPTIONS

The following descriptions are divided by diagram number and then further subdivided by logical circuit blocks. The descriptions follow the order of the diagrams in Section 9. Individual diagrams can be folded out and consulted while studying these descriptions.

Diagram 1 Input Amplifier

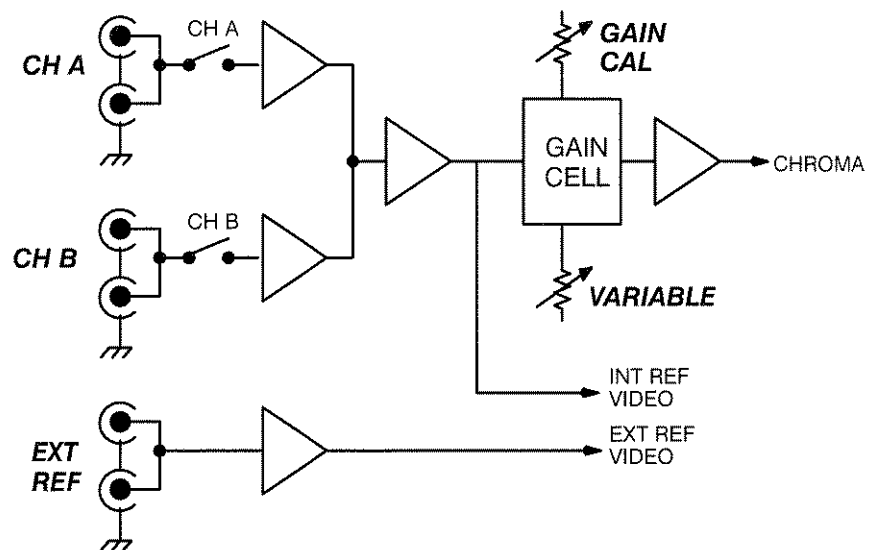

Video signal input to the 1725 Vectorscope is through high-impedance bridging loopthrough inputs. Gain is normalized by the Input Amplifiers prior to being input to the gain cell. The amount of amplification provided by the gain cell is controlled by the Gain Cal, Variable, and the choice of 75% or 100% amplitude color bars.

The External Reference input is also a high-impedance bridging loopthrough, which is dc coupled to a unity gain operational amplifier.

Video Input Amplifiers

The Channel A and Channel B input buffers are ac coupled (C205 and C210), grounded base amplifiers with Q91 and Q97 as the active elements. Q90 is a saturating switch that shunts current away from the Channel B input when Channel A is being displayed. Q98 serves the same purpose when Channel B is being displayed. R468 and C209 are adjustments that match the phases and gains of Channel A and Channel B. They modify the input resistance of Channel B and the input capacitance of Channel A. Signal current flows through either CR44 or CR45 (depending on channel selection) into the summing junction of a differential amplifier (Q88 and Q89) that drives the Output Amplifier (Q87). Output signal drives the gain cell and Sync Separator (Diagram 2).

The External Reference Input Amplifier is nearly identical to the channel inputs and provides a signal to the reference switch. R484 is the input resistor and R457 is the feedback resistor, the combination of which sets the gain to one.

Gain Cell

The gain cell, whose output is chrominance, consists of U39, U41, Q82, and Q86. A bandpass filtered (C177 - R396) signal is fed into pin 6 of U39. U39 consists of a current source (U39C), differential amplifier pair (U39A and B), and a pair of transistors connected as diodes (U39D). U41 consists of four transistors connected in a cross-coupled gain cell arrangement with a transistor used as a heater to keep U41 at the same temperature as U39. The diode-connected pair in U39 is a current-to-voltage converter that drives the gain cell transistors in U41. U38 is an operational amplifier that drives the gain port of the gain cell.

U38 is a buffer amplifier for the various signal levels controlling the gain of U41. Dual Inline Package (DIP) switches (U35), controlled by the microcontroller, switch in various voltages to set gains including the front-panel VARIABLE GAIN.

Q70, Q71, and Q80 form a clamp circuit to turn off the gain cell during sync time. This is accomplished by turning off the gain cell current source U39C.

The gain cell drives a low impedance phase-linear bandpass filter. Frequency range of the filter is approximately 1 MHz to 5 MHz which accommodates both NTSC and PAL subcarrier and sideband frequencies.

The filter output drives an operational amplifier, Q82 and Q85 (Chroma Amplifier). Gain is approximately 16 to boost the chroma signal amplitude back up from the low signal level output by the filter.

Diagram 2 Sync

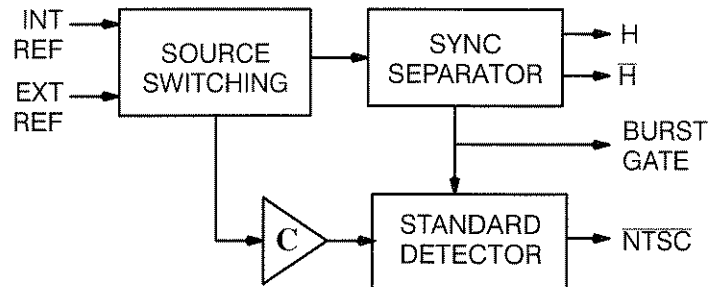

Incoming signal is amplified and fed to the Luminance and Chrominance Amplifiers. Output of the Luminance Amplifier drives the Sync Separator, to generate the H Sync used throughout the vectorscope, and the Burst Gate for the Subcarrier Regenerator and Standard Detector. The Standard Detector outputs a low level for NTSC input signals and high level for PAL input signals.

Reference Switch

U43 is a Quad CMOS switch that selects the appropriate input signal for the Sync Separator, Standard Detector, and the Subcarrier Regenerator. In normal operation, both the sync and subcarrier sources follow the front-panel Reference switch and are driven by A or B when Internal is selected, or by the EXT REF input when External is selected. When P16 is in the 2 and 3 position, the Sync Separator is always driven by the A or B input, even when External Reference is selected. This mode is used if CW Subcarrier is the Reference for a composite video input signal. It will ensure that the clamp pulses are synchronous with the incoming video.

Chrominance Amplifier

The reference signal is ac-coupled through a tuned circuit, C202 and L17, to drive the Chroma Amplifier, Q93 and Q94. Luminance is removed and in normal operation the chrominance is amplified by about three times. With P17 in the 2 and 3 position (External CW Subcarrier input), the gain is changed to slightly less than one.

Luminance Amplifier

The reference signal is dc-coupled to the inverting Luminance Amplifier, Q92, which has unity gain and removes much of the chrominance. The collector of Q92 drives the Sync Separator.

Sync Separator

The Sync Separator strips off and processes the sync from the luminance signal to control the timing circuitry. The Sync Stripper receives its input through C186 and R443 into the base of Q83, a summing junction. Q83 and Q78 form an operational amplifier that inverts the sync signal and clips it near the sync tip.

Amplifier gain, which is high at sync tip time, is set by the combination of R443 (R_i) and R421 (R_f). During non-sync time (active video) CR40 and CR41 are both on, shunting Q78 to reduce amplifier gain and limit saturation so that the response to the next sync transition will be rapid.

During sync time a clamp circuit consisting of Q84 and Q85 maintains the output of the operational amplifier at about +5 V. The output is fed back to maintain the proper level. Q84 and CR42 are a current source that is on during sync tip. At the end of sync time, when Q78 goes low, CR42 is pulled down and Q85 shuts off.

Q74 outputs negative-going sync that has any remaining noise greatly reduced. The output of Q74 is fed back, through CR42, to the clamp circuit, Q85.

Bowes Oscillator

The Bowes Oscillator, Q75 and Q79, is triggered by the leading edge of sync. It accepts triggers only at H intervals, during the vertical interval, to avoid triggering on the wrong equalizing pulses. In the absence of sync the oscillator freeruns so that sample pulses are always available for clamping. The output at the collector of Q79 is negative-going and lasts for approximately 4.5 ms to provide horizontal sync to the rest of the instrument.

U37D inverts the output of the Bowes Oscillator to provide H pulses to the remainder of the instrument. U37A inverts the H pulses to provide /H to the blanking circuitry.

Burst Gate Generator

U40A is a one-shot that provides a positive-going pulse at its output (pin 13) that controls the sampling of burst (Burst Gate) by the Subcarrier Regenerator and Standard Detector. It is triggered by the trailing edge of sync and its Q output (pin 13) is a 4 ms long, positive-going, back porch pulse.

Standard Detector

The Standard Detector is a sampled frequency detector. Reference Video from the Chroma Amp is ac coupled to one signal input of U9 and a tank circuit. The tank circuit resonance frequency is approximately 4 MHz. When the input signal frequency is below resonance, the Carrier input will be delayed from the signal input. When the frequency is above resonance the carrier input phase will lead the signal input. The U9 bias input is controlled by burst gate, it turns on U9 during burst.

The output of U9, at pin 12, will be either a minus term when input signal frequency is below 4 MHz (NTSC) or a positive term when its above 4 MHz (PAL). C42 is a hold capacitor for U12 which is a buffer/decision maker.

The -input of U12 is a voltage level set by a voltage divider R80-R95. The output goes low and stays there for NTSC and high and stays there for PAL. The output is limited to ± 5 V by CR11 and CR12.

Diagram 3 Subcarrier Regenerator

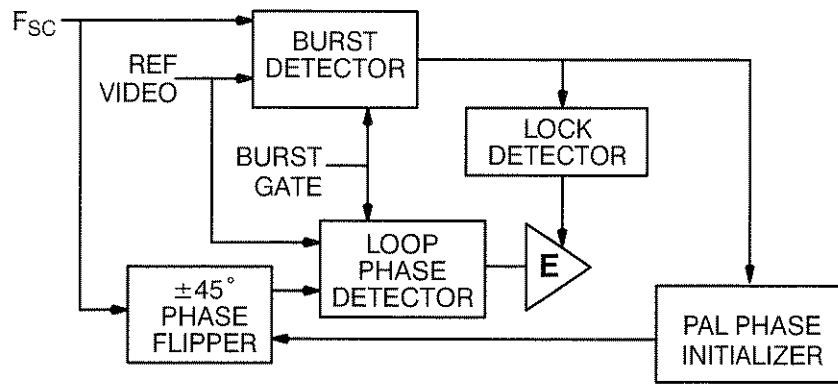

The heart of the Subcarrier Regenerator is a phase locked loop. See Figure 4-2. The Subcarrier Oscillator (VCXO) is a voltage-controlled oscillator that freeruns near the reference subcarrier frequency. The Loop Phase Detector is a mixer that detects phase differences between the reference input and the Subcarrier Oscillator during burst time. The difference output is an error signal proportional to the phase difference detected.

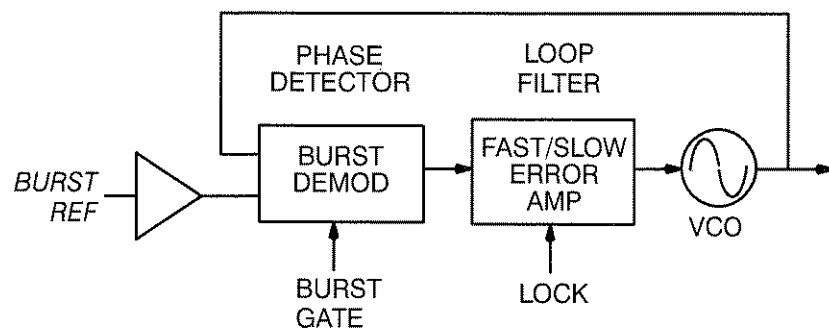

Figure 4-2: Block diagram of the Phase Locked Loop

The error signal drives the Phase Lock Control, which is a lowpass filter to remove high frequency ac components in the error signal. The filter has two bandwidths, a wide one to search for the unlocked signals, and a narrow one to maintain stable phase lock once the signal has been captured.

The Error Amp loop filter completes the loop by controlling the Subcarrier Oscillator. If the input reference changes, the oscillator will follow.

±45° Phase Flipper

When PAL subcarrier is input to the Loop Phase Detector a 90° phase shift is required on alternate lines. This is accomplished by either delaying or advancing the demodulator carrier inputs by 45°.

U33B, which is clocked at an H rate, provides the flipper control signals that alternately turn Q34 and Q35 on and off to provide a 90° subcarrier input phase shift between lines. C108 and R213 provide the 45° phase delay when Q34 is turned on and Q35 is turned off. C106 and R228 provide the 45° advance when Q35 is turned on and Q34 turned off.

When an NTSC signal is input, the preset for U33B is pulled high to turn on Q35 and keeps Q34 turned off. When Q35 is on, the input subcarrier signal is correctly phased for NTSC signals.

Loop Phase Detector and Amplifier

U23 is the Subcarrier Regenerator (Phase Lock) Loop Phase Detector. It is a balanced demodulator, whose carrier input is driven by the VCXO CW sine wave. Its signal input is driven by burst chrominance (Ref Video) from the Chroma Amplifier (Diagram 2). The output of this phase detector is an ac multiplication of the input signals, which occurs only during the time that both of the input signals are present and the demodulator is turned on by the Burst Gate signal. Q32 is the gate switch for the Loop Phase Detector, U23. The average dc output level is proportional to the difference in phase between the inputs. When the loop is locked the output of U23 (pin 12) is zero.

The output corresponding in time to the burst packet is lowpass filtered to remove any chrominance and harmonics to drive U18. The filter L7, C98, and C86 has a 377 MHz bandwidth. U18 is a non-inverting, high-gain operational amplifier used to drive the Error Amplifier.

Error Amplifier

U17 is a non-inverting amplifier whose RC feedback network acts as a lowpass filter to determine the Subcarrier Regenerator loop response. Any input voltage to U17 is amplified and biases the VCXO varicap (Diagram 4).

Loop frequency determines the speed that the loop locks up. When the phase lock loop is not locked up a wider bandwidth is needed. If the loop is unlocked C70, R120, and C57 are the filter elements. When lock up is achieved U13D closes and shunts another filter, consisting of C71, R121, and C58, across the filter to slow down filter response and make it less sensitive to noise.

The Loop Balance control, R161, adjusts the Phase Locked Loop dc offset so that there is no phase shift when there are burst amplitude changes.

Lock Detector and Amplifier

The Lock Detector is similar to the Loop Phase Detector, except that the + Carrier input signal is phase shifted by 90°. This results in the output of the Lock Detector being maximum when the output of the Loop Phase Detector is zero. Since Loop Phase Detector output is zero (phases are matched) during

burst, the Lock Detector provides a large-amplitude pulse occurring only during burst time. When NTSC is selected Q41 is turned on to provide an additional 45° fixed phase shift.

U11 is an integrating amplifier that outputs a low level when the loop is locked. When the subcarrier regenerator is unlocked the output of U11 will be alternately positive and negative, making a net output term of zero. When the output of U11 is low (locked) the output of U14A goes high and Q17 turns on to close switch U13D, which slows down the loop response. The output of U17 is also read by the controller to determine when the loop is locked.

Burst Detector

U25 and U26 form an envelope detector with a current output. When the Subcarrier Regenerator is locked burst current flows through Q24 to U18. Prior to lockup the burst gate is steered through Q21 to U18. When lockup occurs burst sampling occurs on burst. When the Subcarrier Regenerator is not locked sampling occurs in a window corresponding to the Burst Gate signal.

Q22 is an inverter amplifier outputting a burst sample pulse to the Auto Zero circuit on Diagram 4.

Q16 is an integrator that generates a burst present pulse. When the base goes high, Q16 pulls down on the RC network, R117 and C68, which has a long time constant. Q15 is a buffer amplifier for the /BST_HERE (Burst Here) output to the CPU. This signal controls, through the CPU, the front-panel STANDARD indicator if burst is missing.

PAL Phase Initializer

The phase alternate line characteristic of the PAL signal make it possible for the Subcarrier Regenerator to lockup 180° out of phase. If lockup is attempted in this condition the output of the Lock Detector will be positive for one burst and negative for the other, instead of high for both bursts.

When the Subcarrier Regenerator is locked to F_{SC} the Lock Detector outputs only a high at burst time. If the Lock Detector outputs a low at burst time, U14B outputs a low. A low output from U14B turns on Q13 to charge an RC network (C72 and R125) with a time constant of approximately 50 ms. The output of the RC network turns on Q14 which keeps the output of U14B.

The output of U14B pulls the Preset of U33B down to pull up on its Q output. When the Q output goes high Q35 in the 45° Phase Flipper turns on. The next -45° PAL burst that occurs will cause the output of U23 to go low and U25 to go high, which is the locked up state.

When lockup occurs Q10 turns on and locks out PAL Phase Initializer and the Subcarrier Regenerator is locked to the correct phase. In addition, when U14 is locked out the U33B Preset line goes high, which allows it to be clocked by the H rate clock signal.

Diagram 4 VCXO, Phase Shift, and Auto Zero

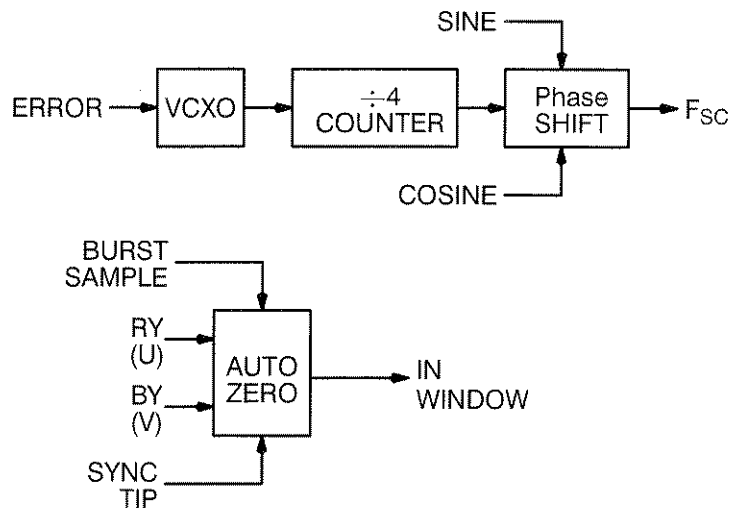

The VCXO is a phase locked, voltage-controlled, switched crystal oscillator that operates at 4 x subcarrier. Crystals are switched to the correct value for the selected input. VCXO output is divided down by a $\div 4$ counter and input to mixers where it is mixed with dc levels corresponding to the selected amount of phase shift. Phase shifted F_{SC} is limited, filtered and output to the Demodulators.

Auto Zero provides a pulse to the controller when the burst phase is in the proper quadrants.

VCXO

The VCXO is a crystal controlled ECL oscillator consisting of U8A and B. Center frequency is established by Y2 for PAL and Y1 for NTSC. The center frequency for the crystal oscillator is fine tuned by Netting Capacitor adjustments C28 and C31. The Error voltage from the Subcarrier Regenerator (Diagram 3) Error Amplifier is applied across a varactor, CR3, which changes capacity with a voltage change. This provides the frequency correction for the VCXO.

When the CAL mode is selected Q9 is turned on hard and saturates to place a high on the control line to free run the oscillator and, if there is a subcarrier present on the input, provide a display of circles.

The 4 x subcarrier output of the oscillator is input to a Johnson Counter, U7A and U7B, which divides its input frequency by 4 to yield a PAL or NTSC in phase and quadrature output.

The in phase output is shaped into a sine wave by a Pi filter consisting of L5, C19, L4, and C24, to provide the F_{SC} signal back to the Subcarrier Regenerator to complete the phase lock loop.

Phase Shift The Phase Shifter itself is an optical encoder that is read by the Controller, which provides DAC Sine and Cosine signals that drive the Control inputs of demodulators, U2 and U210.

The $\div 4$ counter provides in-phase and quadrature outputs to the Phase Shift mixers. Pins 8 and 10 of both mixers have ECL levels of the subcarrier. Pin 1 of both U2 and U210 have levels between + and -2.5 V, generated by the Controller, corresponding to the current setting of the front-panel PHASE control.

The output of the mixers, pin 12, is the result of multiplying and adding the in phase and quadrature components of subcarrier with the sine and cosine levels. L2, C36, and C11 is a filter to remove unwanted resultants. Q3 is a limiter driving a filter consisting of L3, C17, C20, and C21 that outputs a clean phase shifted PAL or NTSC subcarrier to drive the Demodulators (Diagram 4).

Auto Zero The RY (V) and BY (U) are applied to the inputs of a pair of comparators, U16 and U15. A Burst Sample, derived directly from the Subcarrier Regenerator Burst Detector (Diagram 3), gates on the comparators. When RY (V) is 0 and BY (U) is a minus level the burst is in the correct phase.

Sync tip clamping is used to provide a common reference level. At sync tip a pulse turns on Q11 and Q12 grounding the ac coupled RY (V) and BY (U) inputs to the comparators.

U10B and U10C form a window detector that is centered around burst phase. R57 is the Zero Adjustment. In addition to U10B and U10C, U10D goes high when its $-$ input goes low. When the burst occurs in the correct phase there will be a positive pulse output to the Controller to signify burst is correctly phased.

Post Regulators The + and -15 V supplies generated on the Power Supply circuit board are further regulated to meet the onboard needs of the 1725 Main (A3) circuit board. U130 and U31 are the post regulators for the -11.8 V and $+11.8$ V supplies. R272 is the -11.8 V Adjust and R306 is the $+11.8$ V Adjust.

Diagram 5 Demodulator

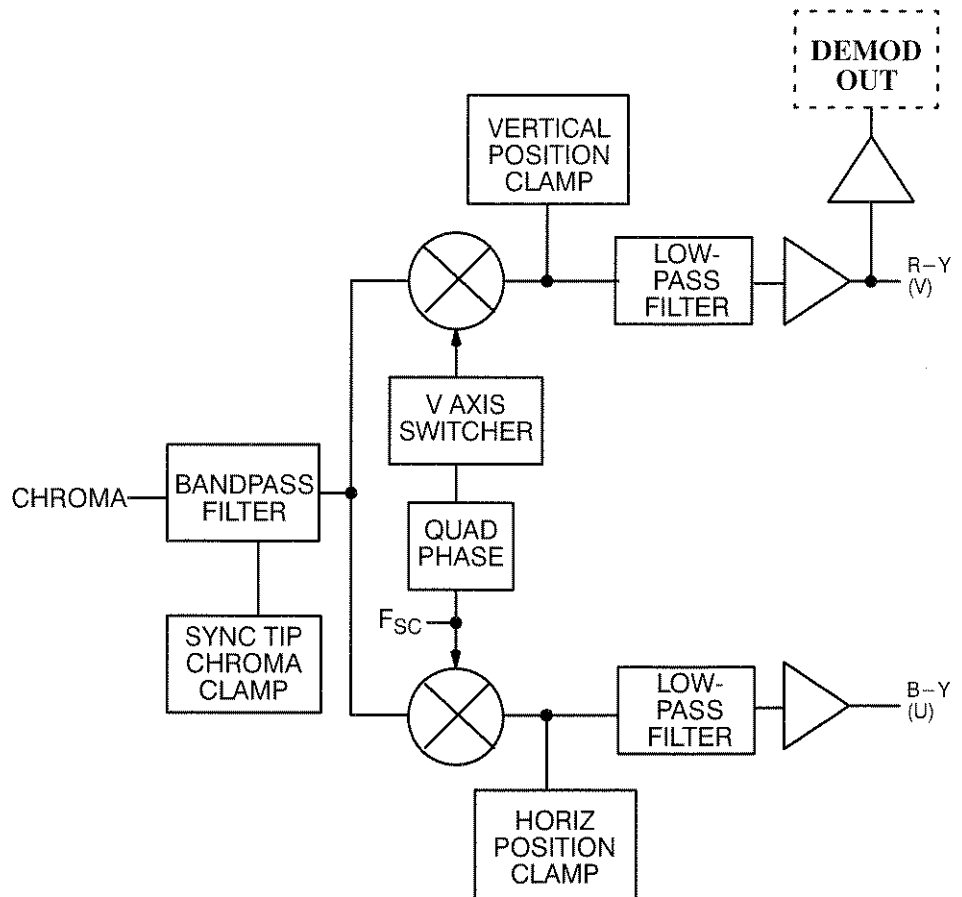

Incoming chrominance is bandpass filtered, clamped at sync tip time, and compared to the phase shifted regenerated subcarrier signal for demodulation. Subcarrier signal is quadrature shifted (90°) before input to the R-Y (V) demodulator. In addition, for PAL applications, and any time the front-panel selected Test Circle is enabled, a V Axis switcher shifts the subcarrier input by 180° for alternate lines.

Output signal from the Demodulators is lowpass filtered and amplified prior to driving the Horizontal and Vertical Output Amplifiers. The output of the R-Y (V) Demodulator is also available through the rear-panel Demodulator Output.

V Axis Switcher

The V Axis Switcher reroutes the V Axis Demodulator carrier input on alternate lines. V Axis switching is enabled when the TEST function is selected from the front panel.

V Axis switching displays the PAL signal with the $-V$ lines overlaid on the $+V$ lines. The resulting display appears as though only the $+V$ signal is displayed,

similar to an NTSC display. This display evaluates relative differences between the +V and -V lines, just as the signal is decoded in a PAL receiver. The Microcontroller pulls the Preset input of U36A (a D-type flip-flop) high, which allows the horizontal sync, clock pulses to toggle its outputs at a line rate. The D input is controlled by another flip-flop, U36B (on Diagram 3), which has identified the +V lines (for PAL) in the Subcarrier Regenerator.

The flip-flop outputs drive Q39 and Q40. A high output turns on the corresponding transistor to shunt the signal at its collector to ground. This alternately grounds and drives the + and - carrier inputs on the V Demodulator with subcarrier to demodulate the -V lines 180° away from the +V lines.

Chrominance Demodulators

The Chrominance Demodulators, U29 and U26, are double-balanced demodulators, whose outputs are voltages proportional to the phase difference between the signal input (pins 1 and 4) and the carrier input (pins 8 and 10). The signal inputs are driven by chrominance from the Gain Cell (Diagram 1). The carrier inputs are driven by a continuous sine wave, at subcarrier frequency, from the Subcarrier Regenerator (Diagram 3). T1 is a balanced transformer driving an LRC delay network, with L10 adjustment for PAL quad phase and C107 adjusted for NTSC quad phase. The V Axis Switching circuit, when operating, determines which carrier input of the R-Y (V) Demodulator is driven by subcarrier. When NTSC is selected U36A Preset input is forced low to turn on Q39 and ground the + Carrier input.

The demodulator gains are set by the R-Y Gain (R277) and the B-Y Gain (R263). The bias is controlled by the Center Dot Position Clamp circuits. R336 provides a small percentage of the Y signal into the X signal to be used as part of the orthogonality adjustment.

Demodulator Output Filters and Amplifiers

A four-pole active lowpass filter (Q54 and Q52 for the R-Y (V) and Q53 and Q58 for the B-Y (U)) removes the high frequency components of the demodulation process. These filters determine the bandwidth of the vector mode signal path to control the rise time and delay of the demodulated signal.

Q64, Q65, and Q66 (for the R-Y/V) and Q61, Q63, and Q67 (for the B-Y/U) are inverting operational amplifiers with a gain of about 15. The amplifier outputs, to drive the Deflection Amplifiers, are from high impedance emitter followers Q64 (R-Y/V) and Q61 (B-Y/U).

Vector Center Dot Position Clamp

The R-Y (V) Demodulator output is also fed back through R299 to a clamp circuit consisting of U28 and Q51. U28 is an operational transconductance amplifier used in a sample-and-hold circuit. The demodulated R-Y chrominance drives the negative input (pin 2), while a voltage, controlled by the Vector Vertical Position control (R258), is the reference level to the positive input (pin 3).

The B-Y (U) Demodulator output is also fed back through R330 to a clamp circuit consisting of U27 and Q46. U27 is an operational transconductance amplifier used in a sample-and-hold circuit. The demodulated B-Y chrominance drives the negative input (pin 2), while a voltage, controlled by the Vector Horizontal Position control (R244), is reference level to the positive input (pin 3).

During the middle of horizontal sync time, a pulse is applied to the bias pin of the amplifier (pin 5) to turn the device on and transfer the voltage levels on the -inputs to the storage capacitors C142 (for R-Y/V) and C134 (for B-Y/U). The stored levels are applied through source followers Q51 (R-Y/V) and Q46 (B-Y/U) to the bias inputs (pin 5) of Demodulators U29 (R-Y/V) and U26 (B-Y/U). This changes the output bias current of the demodulator to change the demodulated signal dc level, which is the dc level for the Deflection Amplifier (Diagram 4).

Vertical and Horizontal Standard Dot Generators

Every other line, during sync time, Q55 and Q60 are turned on to deflect the center dot to the Standard Targets on the graticule. In addition, when NTSC is selected Q57 is turned on, which reduces the amount of current flowing into the vertical amplifier and moves the dot to the NTSC target.

Diagram 6 Deflection Amplifier

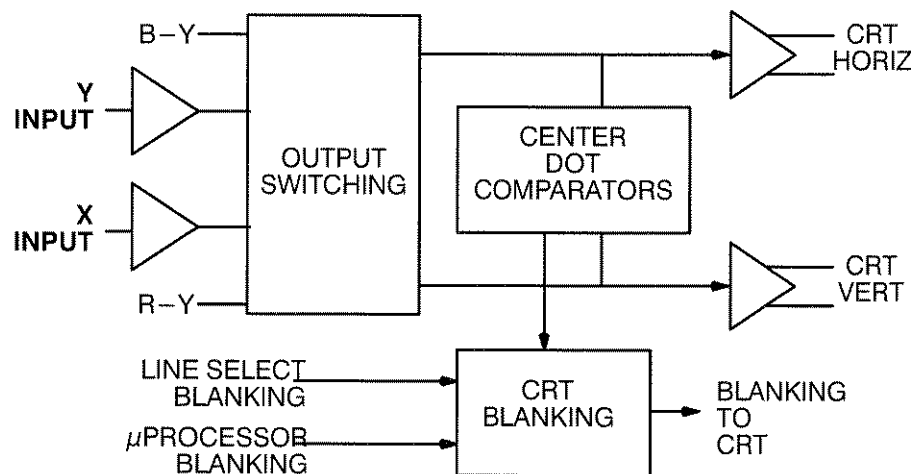

External X and Y signals are input through the rear-panel sub-miniature D-type XY INPUT connector. Output switching selects either the R-Y (V) and B-Y (U) or XY for amplification and display by the Horizontal and Vertical Deflection Amplifiers. Driving signals for the Deflection Amplifiers are also input, as

active driving signals for the Center Dot Comparators, to provide blanking when the crt beam is not deflected away from center screen.

CRT blanking signals from Line Select and the Microcontroller are combined with the vectorscope H rate sync to provide the blanking signal to the grid circuit.

XY Input Amps

U24 is a Quad Operational Amplifier. U24A and B are Balanced Differential Input Amplifiers, intended for audio use. In a 600W system, R207 and R209 can be adjusted to normalize signals from 0 dBm to +12 dBm (2 V_{P-P} to 9 V_{P-P}). The input impedance is greater than 20 kW to ground.

P6 and P7 can be installed on J6 and J7 to increase the gain through the + Inputs of the X and Y amplifiers. These inputs are provided for special non-audio applications where a higher gain may be needed.

U24D and C drive the X and Y Deflection Amplifiers through a Microcontroller enabled switch, U42. A small amount of Y signal is fed through R223 to the X Amplifier for the orthogonality adjustment.

Deflection Amplifiers

The Vertical Deflection Amplifier consists of Q73 and Q77 (a differential pair). Positioning current is input through Q77 with the signal current input through Q73.

Q72 and Q76 are grounded base amplifiers that speed up the amplifiers by minimizing the miller capacitance on Q73 and Q77. CR34, CR35, CR38, and CR39 prevent Q72 and Q76 from saturating when the amplifier is overdriven by large signals. Q68 and Q69 are the current source for the differential pair. The Horizontal Deflection Amplifier is virtually identical in operation to the Vertical Deflection Amplifier.

The Orthogonality control, R387, feeds Y signals into the -input of the Horizontal Deflection Amplifier. Both the vector and XY circuits feed +2% Y signals into the X signal, for use in orthogonality compensation. Adjusting the orthogonality control cancels out some or all of the Y signal in the X Amplifier. The effect of this control is to change the deflection angle between the X and Y axis to compensate for crt geometry.

Center Dot Comparators

U22 is a quad comparator with open collector outputs that are tied together. When both the X and Y signals are close to 0 V (no signal with only a center dot), the output of all the comparators is high. At horizontal sync time U32C opens and C25 discharges in the positive direction toward ground. When the X or Y signal is away from 0 V, after sync time, U32C is closed and the output of at least one of the comparators will be low (-6 V) and C25 recharges.

CRT Blanking

During active line time, if there is signal present, the NOSIG input to U6 is low and the Microcontroller generated /UP BLANK controls unblanking.

U6 outputs three signals: BLANK, to the Z-Axis Control (Diagram 8), DOT to the Standard Dot Generator (Diagram 5), and /CLAMP to the Demodulator Clamp Circuit (Diagram 5). The PAL outputs the signals required for standard dot generation, blanking and unblanking of the crt, and sync tip clamping of the demodulator. See Figure 4-3.

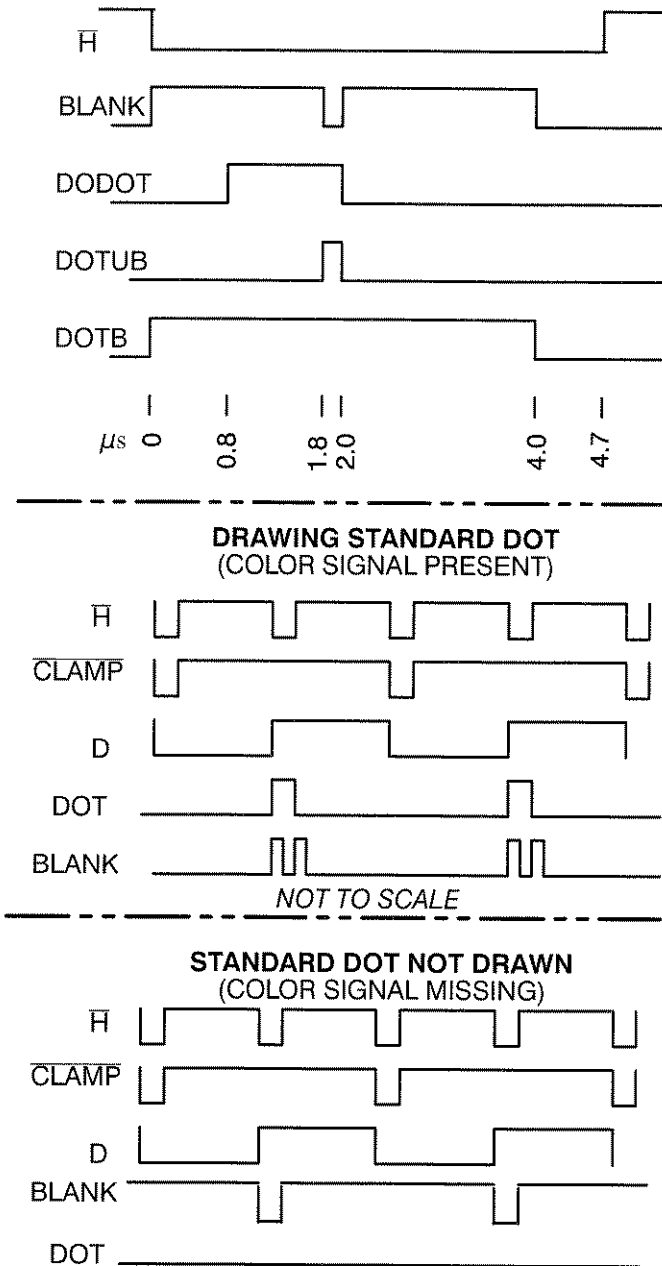

Figure 4-3: Dot timing signals for U6

The DOT output enables the Standard Dot Generators, every other line, at H sync time as dictated by the D (H/2) signal. On these lines the Dot Generators deflect the the center dot and the BLANK signal goes low to unblank the crt. On lines where DOT is low the BLANK still goes low, but in this case the dot remains in the center of the crt.

When there is no burst present, the DOT line remains low and the center dot is displayed on every other line.

When the BLANK output of U6 is high the crt is blanked. The line select blanking signal originates in the 1730-Series when it is a companion to the 1725. When Line Sel Blank is high, the crt is blanked and the line select bright-up circuitry is enabled. The line select blanking signal is low during the selected line to unblank the crt for that line. Q31 enables the bright-up circuitry. CR14 and C73 keep the bright-up circuitry enabled during the time that the Line Sel Blank is low to unblank the crt during the selected line.

When P3 is installed the transitions to the center dot are displayed.

Diagram 7
Microcontroller

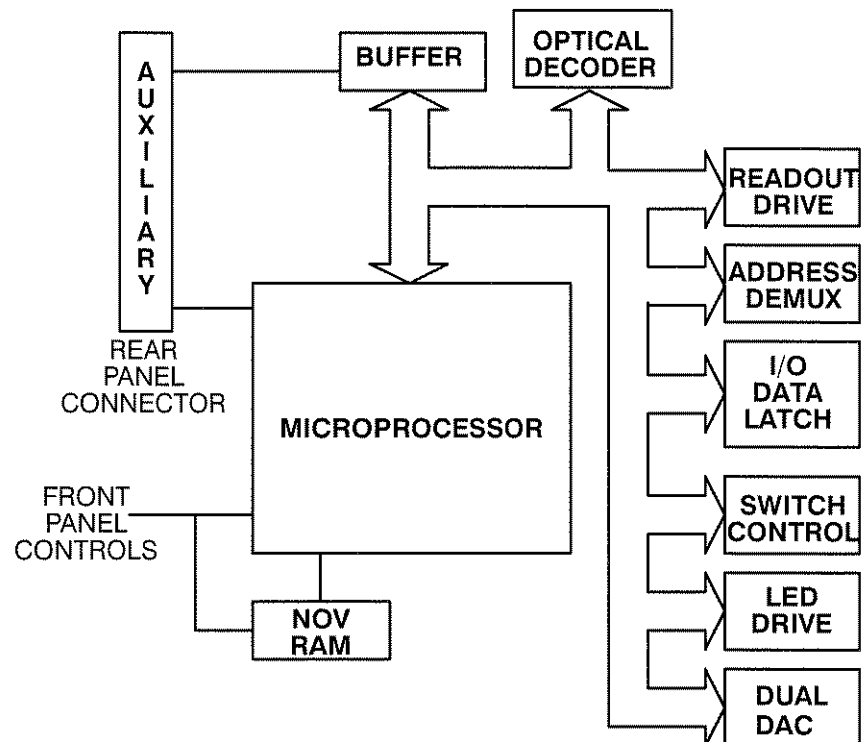

Operation of the 1725 is controlled by the Microprocessor. It controls switching operation by either polling the front-panel switches, or in response to stored/re-

called front-panel configurations (Auxiliary Input from a companion 1730-Series).

Output of the Optical Encoder (PHASE) is decoded and an 8-bit word, corresponding to the control position, is output to the Data bus. A dual Digital-to-Analog Converter decodes the 8-bit word and outputs two dc levels corresponding to the desired in phase and quadrature phase of subcarrier.

In addition, the Microprocessor drives the front-panel indicator light emitting diodes through a light driver.

A Non-Volatile Random Access Memory (NOVRAM) retains the current operating state in the event of power interruption, including operator power down.

Microprocessor

The 1725 is controlled by a Microprocessor and Erasable Programmable Read Only Memory (EPROM). U107 is an 8-bit Microcontroller that operates with U109 (32k X 8 EPROM) or contains its own masked ROM. Pins 32 through 39 of U107 (AD0-AD7) is a multiplexed address and data bus. U110 de-multiplexes the lower address bus for program code retrieval. U107 controls switching in response to front-panel keyboard action. Front-panel switches are ground closures that are matrixed and polled by Port 1 of U107 (Columns 0-2 and Rows 0-2).

In addition, a serial bus structure is input to U107 through pin 10 (RXD) and output through pin 11 (TXD). This is the Auxiliary bus for operation with a companion 1730-Series.

The front-panel LEDs are driven through U103 and U104. The front-panel LEDs light when the light driver outputs are low. In addition, U104 pins 2, and 5 are control lines (75%, 100%, and Variable) for instrument switching functions. Other switching control lines are output through U102.

U106 is the NOVRAM used to retain the current front-panel status and the front-panel status for the Stored Recalls (Auxiliary). Data is written in and read out through pins 3 and 4; pin 1 of U107 (Col 0) controls data in and out. Pin 2 of U107 (Col 1) provides the serial clock. Pin 14 (NOVCE) is the chip enable. These three lines (Clock, Read/Write, and Chip Enable) are active when:

1. Power is turned on.
2. Any front-panel switch is pressed.
3. In Auxiliary, when a Store or Recall is requested from the companion 1730-Series.

U101 is the Power Down Detection circuit. It detects the loss of instrument power in time for the NOVRAM (U106) to execute a save operation. When the +5 V supply drops a few hundred millivolts, pin 7 is pulled low, which causes

U106 to Store its current status. The front-panel and Auxiliary (Store/Recall) data is saved in a matter of milliseconds when the power starts to drop below safe operating levels for the NOVRAM. U108 is a three-terminal regulator operating from the +15 V supply that comes onto the circuit board from the Power Supply circuit board. As soon as the +15 V raises enough to provide a +5 V output from U108, U106 recalls the data saved so that it will be available to the Microprocessor when all supplies are up to their operating tolerances.

**Diagram 8
Control Circuit**

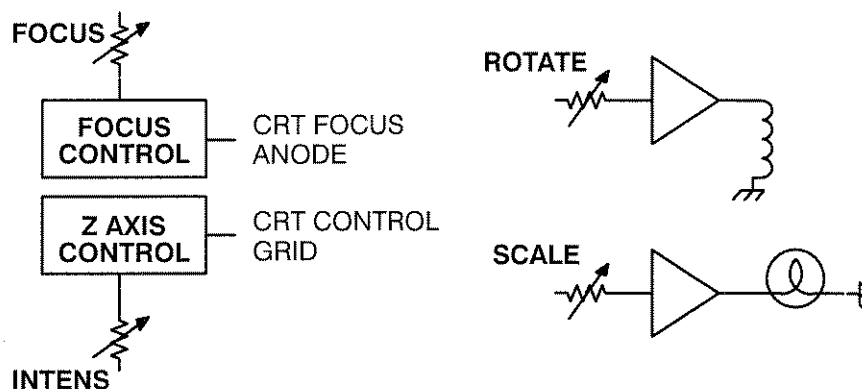

Blanking signals are input to an intensity switching matrix along with a dc voltage level set by the front-panel INTENSITY control. Focus level, for the crt focus anode, is set by regulating the current through a transistor current source. The amount of focus current through the transistor depends on the setting of the front-panel FOCUS control. The effects of small variations in the magnetic field surrounding the instrument are compensated for by an adjustable magnetic field placed around the crt bulb. Scale Illumination for the crt face plate is set by controlling the output amplitude of a triangle generator that drives the scale illumination bulbs.

Switches to select operating modes, controls used with the control circuits, and Light Emitting Diodes (LED) to relay status to the operator are contained on the Front Panel circuit board.

Z-Axis Control

U20 is a transistor array with two of the transistors connected as a differential current switch. The static output current (pin 8) is set by the front-panel INTENSITY control using Q23 (in the FOCUS control circuit) as a current source. The blanking signal is input to the switch through pin 9. When pin 9 goes high the current output (pin 8) is shut off and the Z-Axis Amplifier (Diagram 10) blanks the crt.

In Line Select mode (which requires an external blanking pulse, input through the Auxiliary connector, from a 1730-Series) the intensity setting has to change to brighten up the line(s). This is accomplished by increasing the current through the current source (Q23). U19A is an open collector dual comparator that goes low when the Line Select Blanking occurs, which allows current in R175 to add to the current in Q23, the current source.

Focus Control The Focus control operation must also control two different display criteria. In the normal mode of operation the Focus voltage will be selected by the control setting only, Q27 is off. When a line select unblanking pulse occurs, U19B turns on and additional current flows through Q27. R200, the LS Focus adjustment, is adjusted for optimum focus in Line Select at the normal display focus setting.

Trace Rotation Trace rotation is necessary to compensate for changes in the magnetic field surrounding the 1725. Q42 and Q44 are emitter followers that provide the Trace Rotation current to a coil located inside the crt shield, around the tube. Current amplitude and polarity are controlled by the front-panel ROTATE screwdriver adjustment.

Graticule Illumination U21A is a triangle generator whose output is compared to the front-panel SCALE control output level by U21B (a comparator). The output of U21B is a 6.5 kHz square wave, the duty cycle of which is controlled by the front-panel SCALE ILLUM control. U21B drives saturating switch Q30, which applies the square wave to the graticule lights. L9 and C100 serve as a lowpass filter to keep noise off the +15 V supply.

Switches The eight push-button switches are matrixed for reading by the Microcontroller (Diagram 7). When a push-button is closed a connection is made between one Column and one Row address for the microprocessor. When one of the "Hold for Function" switches, such a MODE or INPUT is held in, the Microcontroller reacts differently and outputs appropriate instructions to the 1725 control circuits.

Controls Four of the front-panel controls operate between two voltage levels. INTENS voltage levels are set by the Z-Axis Control and Focus Control.

The PHASE control, R100, is an optical encoder converting the position of the control into a digital word to be decoded by the Microcontroller (Diagram 7) and converted into voltage levels (sine and cosine) for the Phase Shifter on Diagram 4.

Indicators The indicators are Light Emitting Diodes (LED) operating between +5V and a latched TTL low in the Microcontroller. There are three banks of LEDs. Each

bank has a 100W resistor in series with it (R203, R232, and R235). The microprocessor outputs a TTL low to complete the circuit and light the appropriate LED.

Diagram 9 Low Voltage Power Supply

The Low Voltage Power Supply converts the mains line voltage (90-250 VAC) to supply the power requirements of the instrument. The voltages supplied by the Low Voltage Power Supply are +40 V, ± 15 V, and +5 V.

The Low Voltage Power Supply is called a Flyback Switcher. When switcher mosfet Q9 is turned on, its drain voltage drops to approximately 0 V. The current through the 350 μ H primary winding of T3 begins ramping up. The voltages present at all secondaries is such that the rectifier diodes are reverse biased. Energy is being stored in the magnetic field of T3. When Q9 turns off, the drain voltage “flies back” in a positive direction. Current now flows in all of the secondary windings and supplies power.

Line Rectifier and Filter

The input line voltage is filtered by the rear-panel connector to reduce the electrical noise conducted into or out of the instrument. R89 limits the initial charging current through the rectifier diodes and C54.

CR21, CR22, CR23, and CR24 form a bridge rectifier. C54 filters the 110 to 350 VDC rectifier output. L4 filters the switching noise produced by the switcher. R102 reduces the circulating current in the parallel circuit consisting of L4 and C44. DS4, R93, and R94 form a line voltage indicator. R91 and R92 charge C42. C42 provides power to U5 until the primary housekeeping winding provides power through CR17.

Pulse Width Modulator

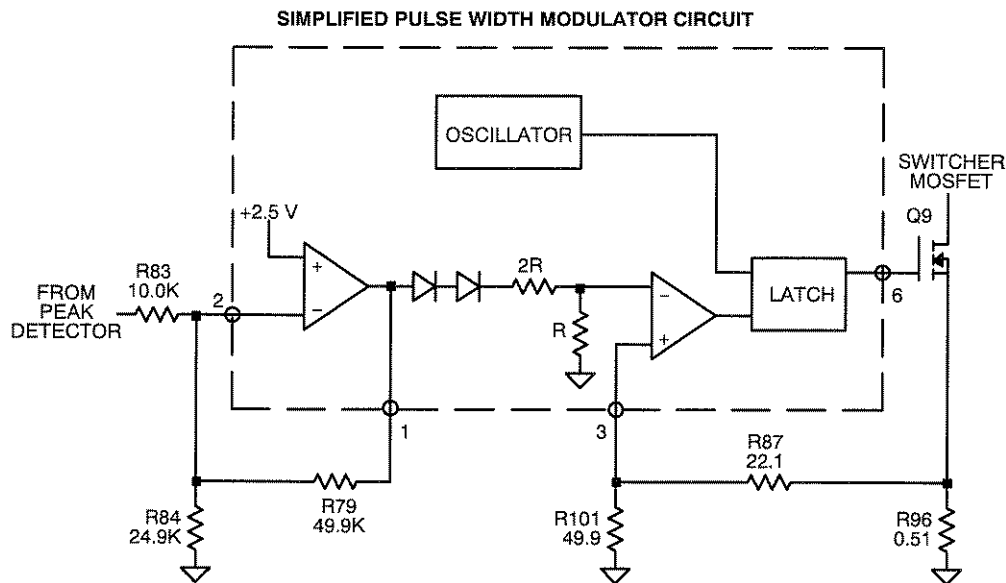

U5 is a current-mode pulse width modulator (PWM). A current-mode PWM uses two feedback loops. The inner current-feedback loop directly controls the switcher mosfet peak current. The outer voltage-feedback loop programs the inner loop peak current trip point.

U5 pin 2 is the inverting input of an internal op-amp. The non-inverting input is set to 2.5 V by an internal voltage reference. Current from the peak detector flows through R83 and R79. R84 provides a $100\ \mu\text{A}$ offset. The voltage at U5 pin 1 will vary in order to maintain U5 pin 2 at 2.5 V.

The voltage at U5 pin 1 is modified by an internal circuit and sets the trip point of the internal comparator. U5 pin 3 is the external input to the comparator. R88 and C52, connected to U5 pin 4, set the internal oscillator to 80 kHz.

The circuit works as follows: The oscillator resets the latch and U5 pin 6 goes high, turning the switcher mosfet on. The current through the switcher mosfet increases, causing the voltage across R96 to increase. This voltage is divided by R87 and R101, and is applied to the comparator (pin 3). When the voltage at U5 pin 3 reaches the comparator trip point, the latch toggles and the switcher mosfet is turned off. This process is repeated at an 80 kHz rate.

C58 increases the PWM noise immunity by rolling off the internal op-amp frequency response. R82 holds the switcher mosfet off as the circuit is powering up. R81 slows the turn-on of the switcher mosfet while CR27 speeds up the turn off.

Output Filters The three output windings supply four output voltages. Each output is rectified by a single diode and filtered by an LC pi filter.

Error Amplifier The Error Amplifier regulates the +5 V output by feeding an error signal to the Pulse Width Modulator. VR1 is a 2.5 V shunt regulator containing an op-amp and a voltage reference. The +5 V is divided by R69 and R70 to provide 2.5 V to VR1. C40 and R71 determine the gain and frequency response of VR1. C64, CR28, and R85 control overshoot of the +5 V at power up. R98 and CR26 provide a minimum operating current for VR1. R68 decouples C39 from VR1.

Feedback Transformer Driver and Peak Detector The 80 kHz sawtooth waveform at U3 pin 3 trips comparator U3. U3 pin 1 then feeds a trigger pulse to one-shot U4. U4 pin 13 outputs a 300 ns pulse to the 130 mA current source consisting of Q7 and Q8. When Q8 turns on, T2 pin 2 is pulled down until CR15 (Error Amplifier) is forward biased. The negative going pulse at T2 pin 2 is peak detected by CR16 and C46. The dc voltage present at the anode of CR16 feeds the pulse-width modulator and the Output Under-Voltage Shutdown circuit. CR29 resets T2 between pulses.

Output Under-Voltage Shutdown If the +5 V is below 4.9 V, the Error Amplifier will cause the Peak Detector output to go below 2.9 V. The output of comparator U3B will pull low and shutdown Pulse Width Modulator U5. C47 and R96 delay the operation of U3B long enough for the power supply to power up. If the +5 V does not reach 4.9 V within 50 ms of power up, U3B will shutdown the switcher. The power supply will then cycle on and off every couple of seconds.

Diagram 10 High Voltage Power Supply

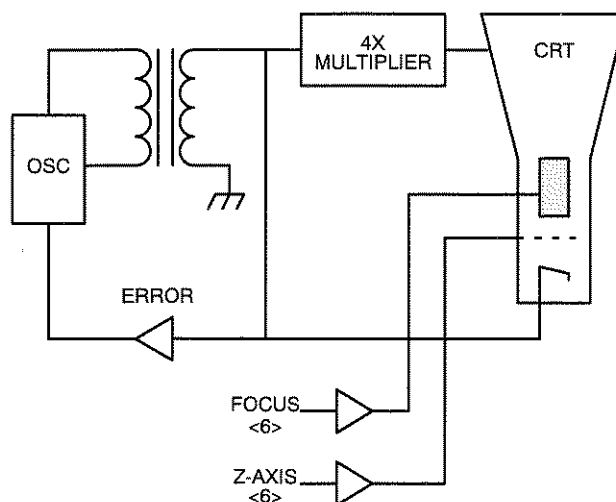

The High Voltage Power Supply generates the heater, cathode, control grid, focus anode, and post accelerating potentials required to display the outputs of the Vertical and Horizontal Output Amplifiers.

HV Osc and Error Amp

The High Voltage Power Supply is generated by a sine wave oscillator and step-up transformer. Q6 and T1 are the principal elements of an Armstrong oscillator running at about 22 kHz. Error Amplifier U2 regulates the +100 V output and keeps the High Voltage Power Supply constant under varying load conditions by controlling the base current to Q6. The +100 V output is regulated directly, while the High Voltage Power Supply is indirectly regulated through a current feedback circuit.

R48, C16, R60, and R64 form the High Voltage Power Supply current feedback circuit. As the current from the High Voltage Power Supply is increased, the voltage to the + side of the Error Amplifier (U2) increases, which increases the base drive to Q6, the HV Osc. This current feedback compromises the regulation of the +100 V supply to keep the high voltage constant with varying intensities.

C66 and Q10 are a start delay circuit that holds the Error Amplifier output low, through CR30, until C66 is charged. Delaying the start of the high voltage oscillator allows the Low Voltage Power Supply to start, unencumbered by the load from the high voltage oscillator.

Power Supply Outputs

CR4 is the high voltage rectifier. Filter capacitors C3, C4, and C8 work with CR4 to provide -2750 V to the crt cathode. U1 is a four-times multiplier providing +11 kV to the CRT anode.

Focus Amplifier

Q1 and Q2 form an operational amplifier that sets the voltage at the bottom of the focus divider. The front-panel FOCUS pot determines the voltage at the bottom of the focus divider. The Center Focus control, R11, is set for optimum beam focus, as viewed on the CRT, with the front-panel FOCUS control set to mid range. Once the Center Focus adjustment has been set, adjusting the front-panel FOCUS control changes the voltage at the bottom end of the divider and, consequently, the voltage on the CRT focus anode.

Grid Drive Circuit

The cathode of the CRT is at a -2750 V potential with the grid coupled to the Z Axis Amplifier by the grid drive circuit. The grid is approximately 75 V negative with respect to the cathode. The 200 V_{p-p} sine wave present at the cathode of CR8 is input to the Grid Drive circuit where it is clipped for use as CRT control grid bias.

The sine wave from the cathode of CR8 is coupled through R47 to a clipping circuit consisting of CR5 and CR6. Clipping level for the positive excursion of the sine wave is set by the CRT Bias adjustment, R58. The negative clipping

level is set by the front-panel INTENSITY control through the Z Axis Amplifier. The clipped sine wave is coupled through C11 to a rectifier made up of CR1 and CR3. The rectified, clipped sine wave is the crt control grid bias voltage. C9 couples the blanking signal from the Z Axis Amplifier to the crt control grid. DS1, and DS2 limit the crt grid to cathode voltage at instrument turn on or off. DS3 limits the crt heater to cathode voltage.

Z Axis Amplifier

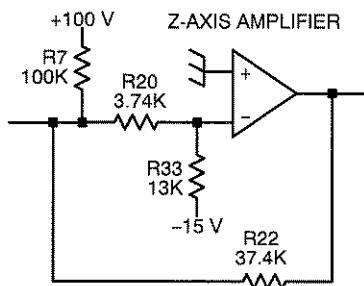

This is an inverting amplifier with negative feedback. R22 is the feedback resistor while R7, R20, and R33 act to maintain the summing junction at +5 V. Without any Z Axis input current, the amplifier output is approximately +10 V. Negative Z Axis input current will cause the output to go positive.

Q5 is a current amplifier feeding the output stage. Q3 and Q4 form a push-pull output stage. Q3 acts as a 2.7 mA constant current pull-up, while Q4 is the pull-down transistor. C6 speeds up the amplifier by coupling ac signals to the base of Q3. CR2 and R41 protect the amplifier during crt arcing.

Section 5

Checks and Adjustments

This section of the manual consists of the procedures to check performance and return the instrument to operation within the stated performance requirements. Each of the two full procedures is preceded by a short-form procedure that can be used by those who are familiar with the Performance Check or Adjustment procedures. Note that the step numbers in the short-form procedures correspond exactly to those in the full procedure.

RECOMMENDED EQUIPMENT LIST

The following equipment is recommended for use in the Performance Check and Adjustment Procedures for this instrument. Other equipment may be substituted; however, care must be used to ensure that the accuracy of the substituted equipment does not compromise the results of a particular procedure step.

Electrical Instruments

1. Test Oscilloscope

Vertical Amplifier: 30 MHz Bandwidth, differential input with 1 mV Sensitivity.

Time Base: 10 ns/div to 5 ms/div sweep speeds, triggering to 5 MHz.

For example: a TEKTRONIX 7603 Oscilloscope with a 7A13 Differential Comparator (needed for use with the TEKTRONIX Return Loss Bridge), and a 7B53A Dual Time Base. Also 10X probes, P6106 (Tektronix Part No. 010-6106-03).

2. Television Signal Generators (two standards required)

Color test signals for the PAL and NTSC television standards: color bar signal, linearity staircase with variable APL, and black burst signal.

For example:

NTSC – TEKTRONIX 1410 with Option AA and Option AB (modified SPG2 and TSG7) and TSG3.

and

PAL – TEKTRONIX 1411 with Option AA and Option AB (modified SPG12 and TSG11) and TSG13.

The 1410, and 1411 Option AA are mainframes with modified SPG2 (NTSC) and SPG12 (PAL) Sync Generators with the added features of: variable subcarrier frequency (± 20 Hz, ± 50 Hz for the 1410; ± 5 Hz, and ± 10 Hz for the 1411), variable burst amplitude, variable sync amplitude, and SCH unlock.

NOTE. *The 1410 Series generators with standard SPG and TSG modules can be used, but this will not allow all checks and adjustments to be made.*

The Signal Generator mainframes can be ordered with one or both options (AA and AB).

The TSG3, and 13 are Modulated Staircase Generators with variable APL.

3. Television Waveform Monitor with Auxiliary Line Select Output.

For example: A TEKTRONIX 1730-Series Waveform Monitor. (A Function Generator may be substituted if a waveform monitor is not available. See item 6, in this list.)

4. Leveled Sine Wave Generator, 250 kHz to 10 MHz and 50 kHz reference frequency

For example: A TEKTRONIX SG503 Leveled Sine Wave Generator installed in a TEKTRONIX TM500-Series Power Module. Flatness $\pm 1\%$, 250 kHz to 50 MHz. The flatness can be calibrated (a chart made of variations) with the TEKTRONIX Peak-to-Peak Detector (015-0408-00).

5. Audio Signal Generator, 10 Hz to 250 kHz

For example: A TEKTRONIX SG505 Option 02 Oscillator installed in a TEKTRONIX TM500-Series Power Module.

6. Function Generator, -10 V pulse at 1 kHz (Needed only if Waveform Monitor is not available.)

For example: A TEKTRONIX FG501A Function Generator installed in a TEKTRONIX TM500-Series Power Supply Module.

7. Voltmeter, 0 to >100 Vdc; accuracy, $\pm 0.1\%$

For example: A TEKTRONIX DM501A in a TM500-Series Power Module.

8. Power Module (required for Items 3, 4, 5, and 6)

For powering and housing TEKTRONIX DM501A, DC503A, SG505 Option 02.

For example: A TEKTRONIX TM506 Power Module.

9. Variable Autotransformer

For example: General Radio Metered Auto Transformer W10MT3W. If 220 Volt operation must be checked, a conversion transformer or appropriate 220 V autotransformer is needed.

Auxiliary Equipment**10. Return Loss Bridge**

Range, at least 46 dB return loss sensitivity, 50 kHz to 6 MHz.

For example: Tektronix Part No. 015-0149-00.

11. 75 Ω Terminators (three required; two must be feed-through types)

For example: End-line, 75 Ω terminator (Tektronix Part No. 011-0102-00), and a feed through, 75 Ω terminator (Tektronix Part No. 011-0103-02).

12. 75 Ω Coaxial Cable (3 required)

For example: 42 inch RG59U (Tektronix Part No. 012-0159-00).

13. 10X, 75 Ω Attenuator

For example: Tektronix Part No. 011-0061-00.

14. Alligator Clip to BNC Adapter

For example: Tektronix Part No. 013-0076-00.

15. Dual Input Coupler

Matched BNC cable-T for making phase comparisons between two inputs. Matched length of the two arms within ± 0.1 inch.

For example: Tektronix Part No. 003-0837-00.

16. Precision 50 Ω Coaxial Cable

Tektronix Part No. 012-0482-00 (used with the TEKTRONIX SG503).

17. 50 Ω to 75 Ω Minimum Loss Attenuator

Tektronix Part No. 011-0057-00.

18. XY Input Test Connector

Fifteen-pin, subminiature D-type connector (for example: Tektronix Part No. 131-0459-00), modified to input the audio signal for XY checks and adjustments. See Figure 5-1.

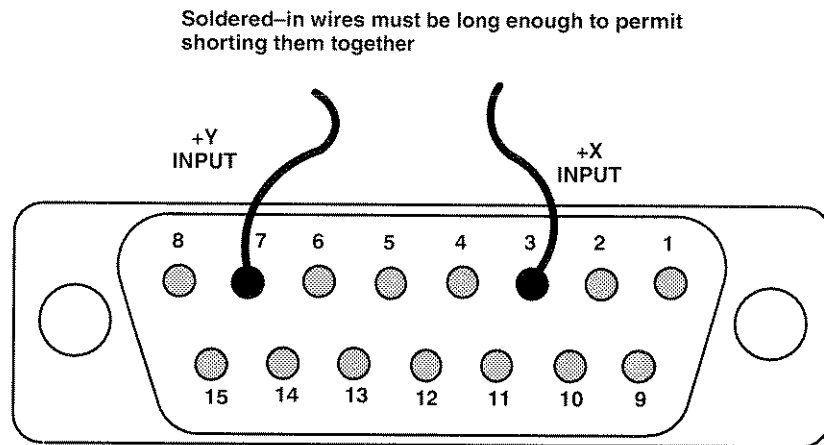

Figure 5-1: XY Input test connector

PERFORMANCE CHECK

The short form procedure that follows is intended for those familiar with how to accurately check out this instrument performance. The full Performance Check Procedure follows the Short Form Performance Check procedure; step numbers are identical in both procedures.

Short Form Performance Check

1. PRELIMINARY SETUP

2. CHECK POWER SUPPLY OPERATION

REQUIREMENT — Check ac input range, 90–132 V or 180–250 V as determined by the Line Voltage Selector switch.

- c. **CHECK** – for stable operation over the voltage range.

3. CHECK SYNCHRONIZATION

REQUIREMENT— Stable display with composite video or black burst with 40 IRE (300 mV PAL) sync ± 6 dB.

- d. **CHECK** – for stable display in both EXT and INT reference modes.
- f. **CHECK** – for a stable display in both EXT and INT reference modes.

4. CHECK DEMODULATOR NTSC AND PAL CHANNEL BANDWIDTH

REQUIREMENT — Upper -3 dB point: $F_{SC} + (400 \text{ kHz to } 600 \text{ kHz})$.
Lower -3 dB point: $F_{SC} - (400 \text{ kHz to } 600 \text{ kHz})$.

- f. **CHECK** – that the frequency readout on the Sine wave Generator is between 2.98 to 3.18 MHz.
- i. **CHECK** – that the frequency readout on the Sine wave Generator is between 3.98 to 4.18 MHz.
- n. **CHECK** – that the frequency readout on the Sine wave Generator is between 3.83 to 4.03 MHz.
- q. **CHECK** – that the frequency readout on the Sine wave Generator is between 4.83 to 5.03 MHz.

5. CHECK COLOR BAR DECODING ACCURACY

REQUIREMENT — Vector Phase accuracy within $\pm 1.25^\circ$. Vector Gain accuracy typically within ± 1.25 IRE (NTSC) or $\pm 2.5\%$ (PAL).

- g. **CHECK** – that all of the vectors fall within $\pm 1.25^\circ$ and ± 1.25 IRE of the target centers. These specifications represent one-half the dimension from the center cross of a vector target to the edge of the small inner box.
- j. **CHECK** – that all of the vectors fall within $\pm 1.25^\circ$ and ± 1.25 IRE of the target centers. These specifications represent one-half the dimension from the center cross of a vector target to the edge of the small inner box.
- n. **CHECK** – that all of the vectors fall within $\pm 1.25^\circ$ and $\pm 2.5\%$ of the target centers. These specifications represent one-half the dimension from the center cross of a vector target to the edge of the small inner box.
- q. **CHECK** – that all of the vectors fall within $\pm 1.25^\circ$ and $\pm 2.5\%$ of the target centers. These specifications represent one-half the dimension from the center cross of a vector target to the edge of the small inner box.

6. CHECK SUBCARRIER REGENERATOR PERFORMANCE

REQUIREMENT — Pull in range: $F_{SC} \pm 50 \text{ Hz}$ ($\pm 10 \text{ Hz}$ for PAL). Pull in time less than 1 second. Phase shift at these frequency offsets less than 0.5° . Phase shift with ± 6 dB burst amplitude change less than 2° .

- c. **CHECK** – that the 1725 locks to the generator within 1 second at these frequencies.
- d. **CHECK** – that the 1725 display does not change by more than $\pm 0.5^\circ$ at these frequencies.

- g. **CHECK** – that the 1725 burst vector phase does not change by more than $\pm 2^\circ$ within the + and –6 dB range.
- j. **CHECK** – that the 1725 locks to the generator within 1 second at these frequencies.
- k. **CHECK** – that the 1725 display does not change by more than $\pm 0.5^\circ$ at these frequencies.
- n. **CHECK** – that the 1725 burst vector phase does not change by more than $\pm 2^\circ$ within the + and –6 dB range.

7. CHECK PHASE ACCURACY

REQUIREMENT — Phase shift with signal input channel change less than 0.5° . Phase shift with +3 to –6 dB VAR GAIN change: less than 1° . Burst jitter: less than 0.5° .

- d. **CHECK** – that the CH–A to CH–B phase match is within $\pm 0.5^\circ$.
- h. **CHECK** – that there is less than 0.5° burst jitter with either INT or EXT REF.
- j. **CHECK** – that there is less than 1° phase change over this range.

8. CHECK AMPLIFIER LINEARITY

REQUIREMENT — Differential Phase: less than 1° for a 10 to 90% APL Linearity Staircase. Differential Gain: less than 1% for a 10 to 90% APL Linearity Staircase.

- d. **CHECK** – that dots are overlayed to $\pm 1^\circ$.
- g. **CHECK** – that dot is overlayed to $\pm 1^\circ$, at both 10 and 90% average picture levels.

9. CHECK CHROMINANCE VECTOR CLAMP PERFORMANCE

REQUIREMENT — Clamp stability: $1/64''$ (0.4 mm) or less center dot movement as the PHASE control is rotated throughout its range. Position Control range: at least $1/4''$ (6 mm) from the center at either limit.

- b. **CHECK** – that the center dot of the vector display moves less than $1/64''$ (0.4 mm) as the PHASE control is rotated.
- c. **CHECK** – while varying both screwdriver position controls throughout their range, that the range of each control is greater than + and – $1/4''$ (6 mm) from the centered position.

10. CHECK VARIABLE GAIN

REQUIREMENT — Input subcarrier signals between -6 dB and $+14$ dB (29.5 IRE and 147 IRE NTSC; 0.210 V and 1.05 V for PAL) can be adjusted to the burst amplitude.

- d. **CHECK** — that the burst vector can be adjusted to the 75% amplitude target.
- g. **CHECK** — that the burst vector can be adjusted to the compass rose.

11. CHECK AUTO PHASE ACCURACY

REQUIREMENT — Bursts return to targets $\pm 2^\circ$, in 1.5 seconds when AUTO is pushed.

- d. **CHECK** — that the tip of the burst vector returns to $0^\circ \pm 2^\circ$, in 1.5 seconds.
- h. **CHECK** — that the tip of the burst vector returns to $0^\circ \pm 2^\circ$, in 1.5 seconds.
- l. **CHECK** — that the tip of the burst vector returns to $0^\circ \pm 2^\circ$, in 1.5 seconds.

12. CHECK TRACE ROTATION RANGE

REQUIREMENT — Range greater than $\pm 1^\circ$ from horizontal.

- e. **CHECK** — that either end of the trace can be moved more than 1° (one-half minor division on the compass rose) either direction from horizontal.

13. CHECK XY INPUT PHASE MATCHING

REQUIREMENT — less than a trace width of separation at 100 kHz.

- d. **CHECK** — for a trace width or less separation in the diagonal display.

14. CHECK XY FREQUENCY RESPONSE

REQUIREMENT — the -3 dB point at 200 kHz or greater in standard mode; 100 kHz or more in High Gain mode.

- d. **CHECK** — that the display reaches the -3 dB gaps in the horizontal axis or beyond.

- h. **CHECK** – that the display reaches the –3 dB gaps in the horizontal axis or beyond.
- i. **CHECK** – that the display reaches the –3 dB gaps in the horizontal axis or beyond.
- p. **CHECK** – that the display reaches the –3 dB gaps in the vertical axis or beyond.

15. CHECK RETURN LOSS

REQUIREMENT — Return loss for each input: at least 40 dB from 50 kHz to 6 MHz (instrument on or off, input in use or not, for any deflection factor setting).

- c. **CHECK** – that the return loss of the CH–A, CH–B, and EXT REF INPUTs is better than 40 dB, from 50 kHz to 6 MHz. Make this check (within this frequency range) with the instrument power on and off. Using the Nomograph supplied with the Return Loss Bridge, 40 dB converts to 5 mV on the test oscilloscope vertical scale.

Long Form Performance Check

The following preparations should be made before starting the Performance Check.

Set the 1725 as follows:

Table 5–1: Preliminary Control Settings

POWER	ON
INTENSITY	Adjust as indicated in numbered steps.
FOCUS	
SCALE	
MODE	VECT
REF	INT
INPUT	CH–B
VARIABLE	Off
BARS	75%
AUXILIARY	Off

NOTE. *CH B input is used for NTSC signal inputs and CH A input is used for PAL signal inputs throughout this procedure.*

1. PRELIMINARY SETUP

- a. Connect the variable autotransformer to the AC power connector. Turn on the autotransformer and set the output for the local nominal mains voltage (110 V or 220 V).
- b. Connect the NTSC Composite Color Bar signal with 100% Peak White Bar and 75% amplitude bars to the CH-B INPUT and terminate the opposite side of the loop through with a 75 Ω terminator. See Figure 5-2.

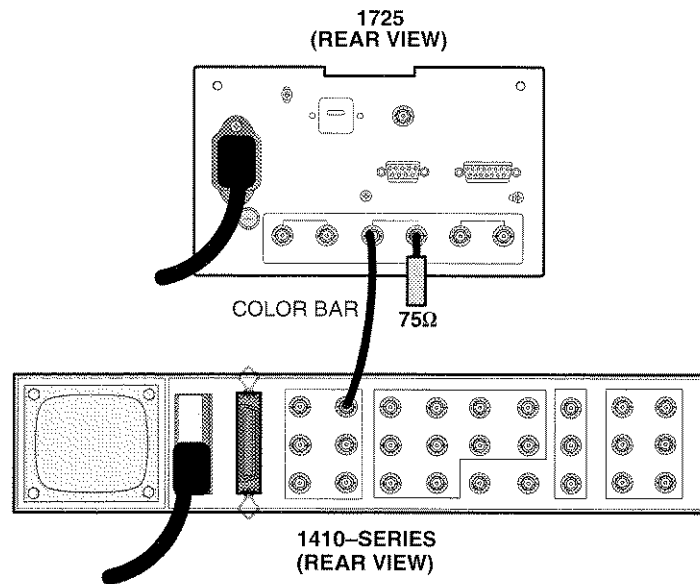

Figure 5-2: Initial equipment connections for performance checks

2. CHECK POWER SUPPLY OPERATION

REQUIREMENT — Check ac input range, 90 – 250 V.

- a. Turn on the 1725 and adjust the controls for a useable display.
- b. Vary the autotransformer from low line to high line voltage (90 – 132 V for 110 V operation, or 180 – 250 V for 220 V operation).
- c. **CHECK** – for stable x operation over the appropriate voltage range.
- d. Return the autotransformer output to the local nominal mains voltage.

3. CHECK SYNCHRONIZATION

REQUIREMENT — Stable display with composite video or black burst with 40 IRE (300 mV PAL) sync ± 6 dB.

- a. Disconnect the color bar signal and loop through connect the black burst output from the 1410 SPG2 Mod AA as shown in Figure 5-3.

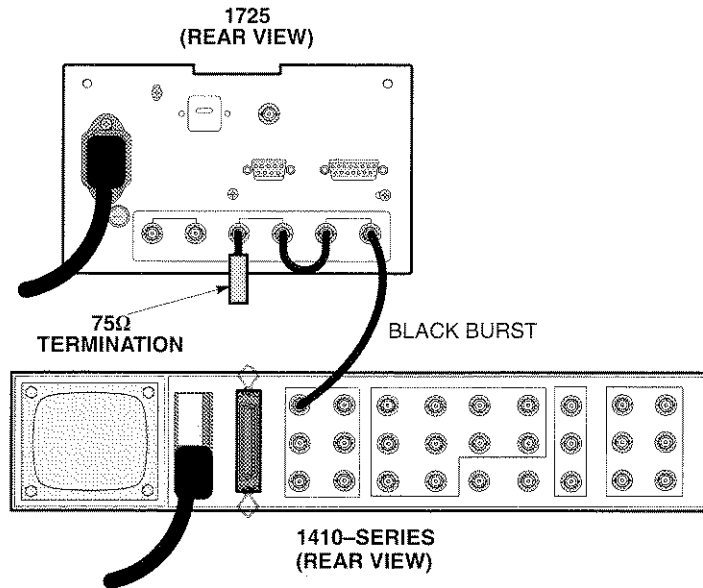

Figure 5-3: Equipment connections to check synchronization

- b. Push the 1725 VAR ON and adjust the VAR control to place the vector tip on the compass rose.
- c. Remove the 75Ω terminator from CH-B.
- d. **CHECK** – for stable display in both EXT and INT reference modes.
- e. Triple terminate CH-B, using three 75Ω terminators.
- f. **CHECK** – for a stable display in both EXT and INT reference modes.
- g. Disconnect the black burst signal and remove two of the terminators from CH-B.

4. CHECK DEMODULATOR NTSC AND PAL CHANNEL BANDWIDTH

REQUIREMENT — Upper -3 dB point: $F_{SC} + (400 \text{ kHz to } 600 \text{ kHz})$.
 Lower -3 dB point: $F_{SC} - (400 \text{ kHz to } 600 \text{ kHz})$.

- a. Set the 1725 MODE to VECTOR and REF to EXT.
- b. Connect the Leveled Sine wave Generator through the Precision 50 Ω cable and 50 Ω to 75 Ω Minimum-Loss Attenuator to the CH-B INPUT. See Figure 5-4.

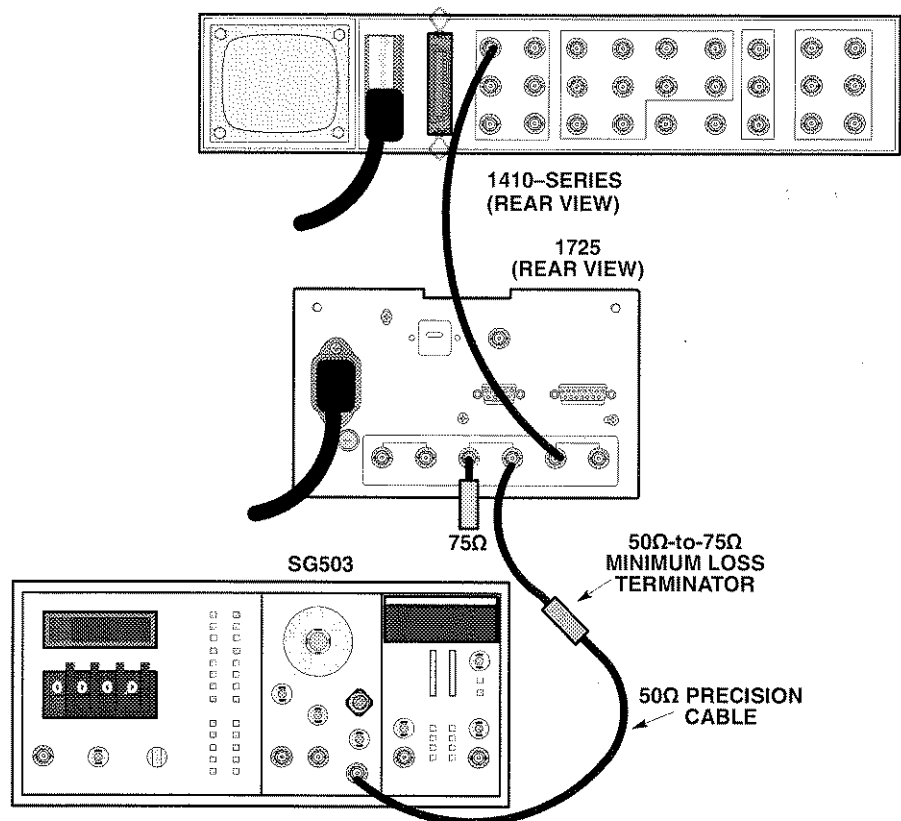

Figure 5-4: Initial connections for checking bandwidth

- c. Connect the NTSC black burst signal to the EXT REF.
- d. Set the Sine wave Generator frequency to 3.58 MHz and adjust the Sine wave Generator amplitude so that the circle overlays the vector graticule circle.
- e. Decrease the Sine wave Generator frequency until the perimeter of the circle touches the -3 dB (70%) point gaps on the vertical graticule axis. See Figure 5-5.
- f. **CHECK** – that the frequency readout on the Sine wave Generator is between 2.98 to 3.18 MHz.
- g. Repeat parts e. and f. of this step for the horizontal graticule axis.

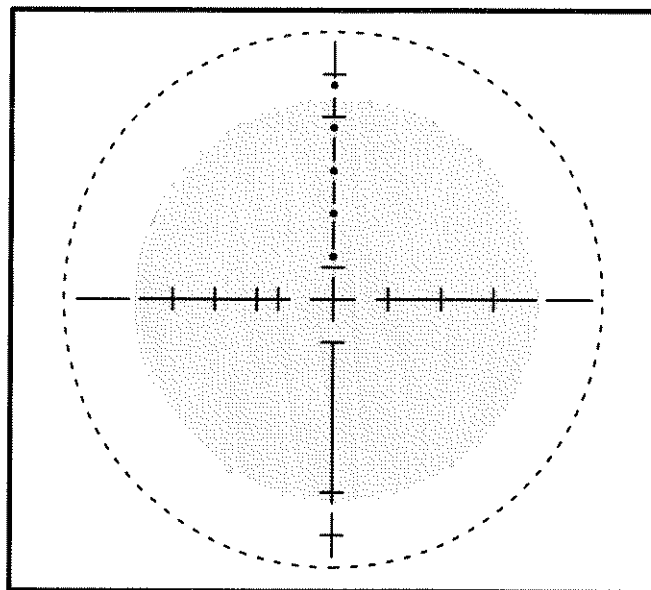

Figure 5-5: Perimeter of the sine wave circle just touches -3 dB point gaps

- h. Increase the Sine wave Generator frequency until the perimeter of the circle touches the -3 dB (70%) point gaps on the vertical graticule axis.
- i. **CHECK** – that the frequency readout on the Sine wave Generator is between 3.98 to 4.18 MHz .
- j. Repeat steps h. and i. for the horizontal graticule axis.
- k. Connect the PAL black burst signal to the 1725 EXT REF.
- l. Adjust the Sine wave Generator frequency to 4.43 MHz and adjust the Sine wave Generator amplitude so that the circle overlays the vector graticule circle.
- m. Decrease the Sine wave Generator frequency until the perimeter of the circle touches the -3 dB (70%) point gaps on the vertical graticule axis. See Figure 5-5.
- n. **CHECK** – that the frequency readout on the Sine wave Generator is between 3.83 to 4.03 MHz.
- o. Repeat steps m. and n. for the horizontal graticule axis.
- p. Increase the Sine wave Generator frequency until the perimeter of the circle touches the -3 dB (70%) point gaps on the vertical graticule axis.
- q. **CHECK** – that the frequency readout on the Sine wave Generator is between 4.83 to 5.03 MHz.

- r. Repeat steps p. and q. for the horizontal graticule axis.
- s. Disconnect the Sine wave Generator input.

5. CHECK COLOR BAR DECODING ACCURACY

REQUIREMENT — Vector Phase accuracy within $\pm 1.25^\circ$. Vector Gain accuracy typically within ± 1.25 IRE (NTSC) or $\pm 2.5\%$ (PAL).

- a. Set the 1725 REF to INT.
- b. Connect the PAL Color Bar signal to the CH-A INPUT and terminate the remaining side of the loop through connector with a 75Ω terminator. See Figure 5-6.
- c. Connect the NTSC color bar signal to the CH-B INPUT and terminate the remaining side of the loop through connector with a 75Ω terminator. See Figure 5-6.

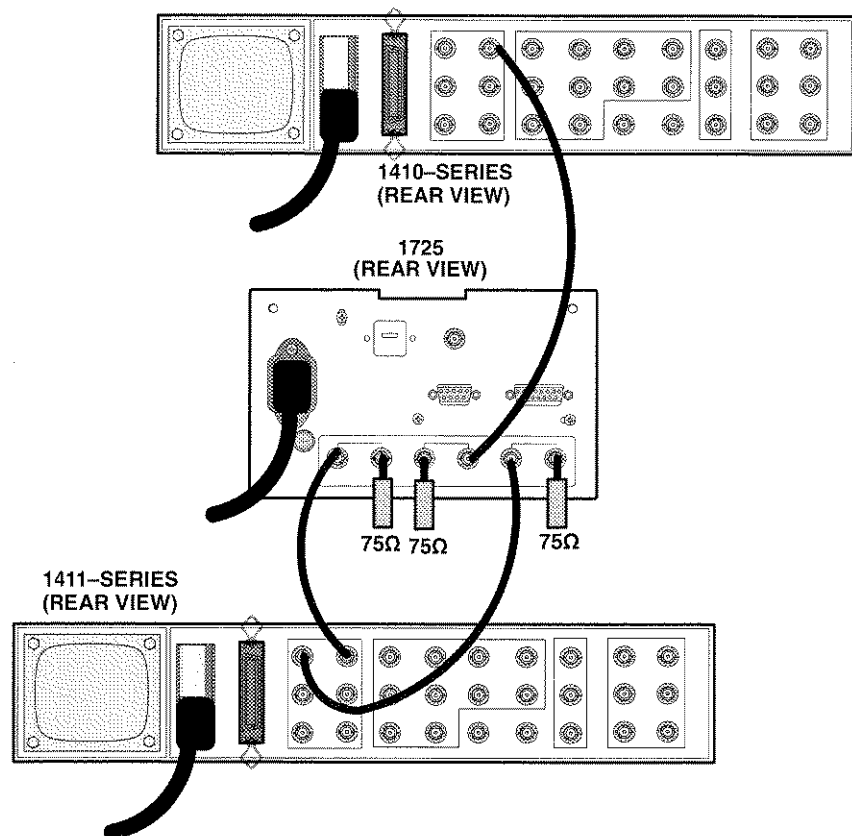

Figure 5-6: Equipment connections to check decoding accuracy

- d. Set the 1725 INPUT to CH-B.
- e. Set the NTSC television signal generator for 75% amplitude color bars.
- f. Adjust the PHASE control to place the vector dots in their graticule targets.
- g. **CHECK** – that all of the vectors fall within $\pm 1.25^\circ$ and ± 1.25 IRE of the target centers. These specifications represent one-half the dimension from the center cross of a vector target to the edge of the small inner box.
- h. Set the 1725 BARS to 100%.
- i. Set the NTSC television signal generator for 100% color bars.
- j. **CHECK** – that all of the vectors fall within $\pm 1.25^\circ$ and ± 1.25 IRE of the target centers. These specifications represent one-half the dimension from the center cross of a vector target to the edge of the small inner box.
- k. Select CH-A.
- l. Set the PAL television signal generator for 100% amplitude color bars and set the 1725 BARS to 100%.
- m. Adjust the PHASE control to place the vector dots in their graticule targets.
- n. **CHECK** – that all of the vectors fall within $\pm 1.25^\circ$ and $\pm 2.5\%$ of the target centers. These specifications represent one-half the dimension from the center cross of a vector target to the edge of the small inner box.
- o. Set the PAL television signal generator for 75% amplitude color bars and set the 1725 BARS to 75%.
- p. Adjust the PHASE control to place the vector dots in their graticule targets.
- q. **CHECK** – that all of the vectors fall within $\pm 1.25^\circ$ and $\pm 2.5\%$ of the target centers. These specifications represent one-half the dimension from the center cross of a vector target to the edge of the small inner box.
- r. Turn on 1725 +V.
- s. **CHECK** – that the Burst vectors can be overlaid to within 2% using the PHASE control.

6. CHECK SUBCARRIER REGENERATOR PERFORMANCE

REQUIREMENT — Pull in range: $F_{SC} \pm 50$ Hz (± 10 Hz for PAL). Pull in time less than 1 second. Phase shift at these frequency offsets is within $\pm 2^\circ$. Phase shift with ± 6 dB burst amplitude change less than 2° .

- a. Turn off 1725 +V.
- b. Change the generator's subcarrier frequency by ± 10 .
- c. **CHECK** — that the 1725 locks to the generator within 1 second at these frequencies.
- d. **CHECK** — that the Vectorscope display does not change by more than $\pm 2^\circ$ at these frequencies.
- e. Change the CH-A input to the Black Burst signal from the PAL Television Signal Generator.
- f. Vary the generator Burst Amplitude + and -6 dB from the calibrated amplitude (1/2 to 2X amplitude). *Requires SPG12 Mod AA.*
- g. **CHECK** — that the 1725 burst vector phase does not change by more than $\pm 2^\circ$ within the + and -6 dB range.
- h. Select the CH-B INPUT.
- i. Change the generator's subcarrier frequency by ± 50 Hz
- j. **CHECK** — that the 1725 locks to the generator within 1 second at these frequencies.
- k. **CHECK** — that the Vectorscope display does not change by more than $\pm 2^\circ$ at these frequencies.
- l. Change the CH-B input to the Black Burst signal from the NTSC Television Signal Generator.
- m. Vary the generator Burst Amplitude + and -6 dB from the calibrated amplitude (1/2 to 2X amplitude). *Requires SPG2 Mod AA.*
- n. **CHECK** — that the 1725 burst vector phase does not change by more than $\pm 2^\circ$ within the + and -6 dB range.

7. CHECK PHASE ACCURACY

REQUIREMENT — Phase shift with signal input channel change less than 0.5° . Phase shift with $+3$ to -6 dB VAR GAIN change: less than 1° . Burst jitter: less than 0.5° .

- a. Connect the PAL Color Bar signal through a 75Ω feed through terminator and a dual input coupler to the CH-A and CH-B input connectors. Connect the black burst signal to the EXT REF loop through and terminate in 75Ω. See Figure 5-7.

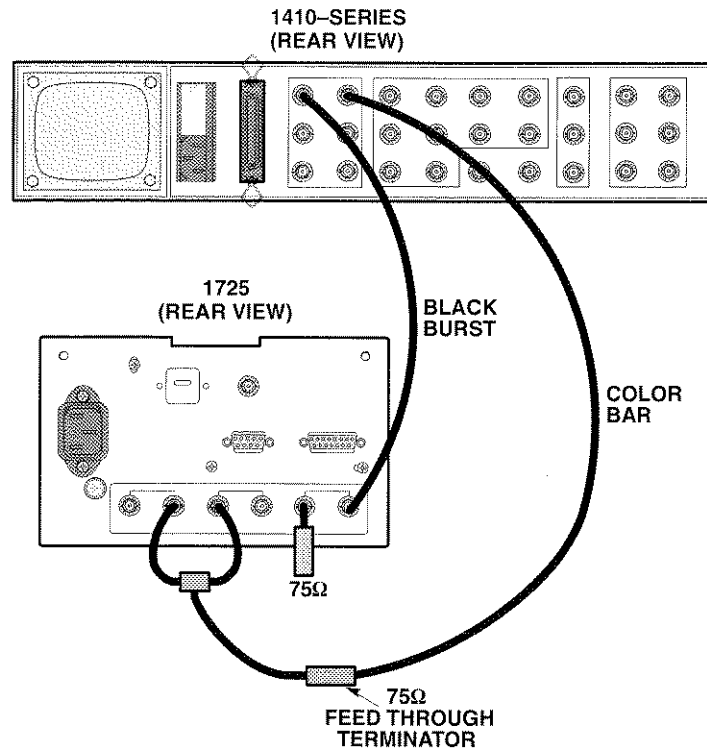

Figure 5-7: Signal connection for checking CH-A/CH-B phase matching.

- b. Select EXT REF.
- c. Alternately select INPUT A and B.
- d. **CHECK** – that the CH-A to CH-B phase match is within $\pm 0.5^\circ$.
- e. Remove the black burst signal and termination from the EXT REF INPUT.
- f. Move the connection from CH-A to the EXT REF. See Figure 5-8.
- g. Alternately display INPUT B with INT and EXT REF.
- h. **CHECK** – that there is less than 0.5° burst jitter with either INT or EXT REF.
- i. Disconnect the color bar signal from the dual input coupler.

- j. Apply the NTSC Linearity Staircase signal.

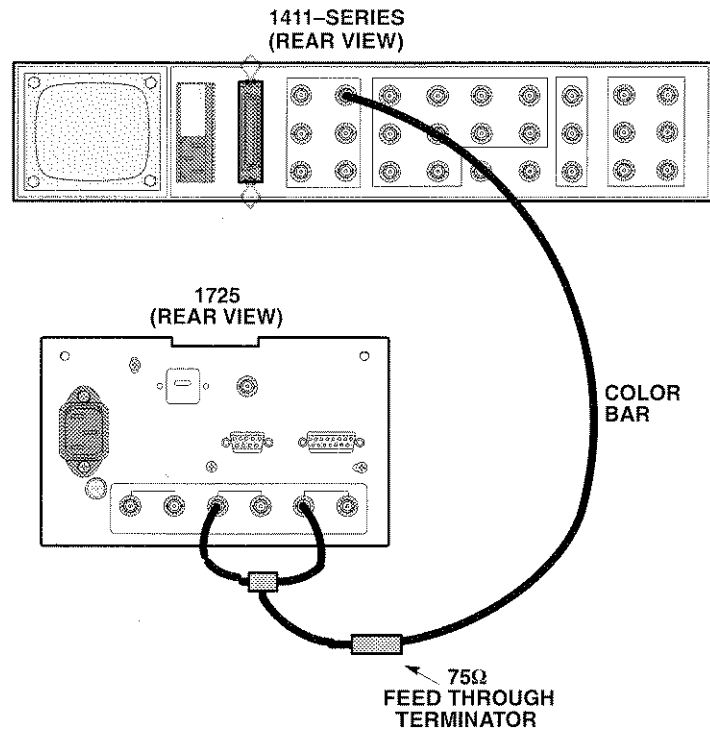

Figure 5-8: Equipment connections for checking burst jitter

- k. Set the NTSC Staircase generator for 5-step and 40 IRE subcarrier.
- l. Set the Staircase vector dot to the left horizontal graticule line with the PHASE control.
- m. Turn ON VARIABLE GAIN and rotate the VARIABLE control until the staircase vector is one-third longer (+3 dB) and to the point that the vector has been decreased to one-half of the original vector length (-6 dB).
- n. **CHECK** – that there is less than 1° phase change over this range.

8. CHECK AMPLIFIER LINEARITY

REQUIREMENT — Differential Phase: less than 1° for a 10 to 90% APL Linearity Staircase. Differential Gain: less than 1% for a 10 to 90% APL Linearity Staircase.

- a. Turn off VARIABLE GAIN.

- b. Use the PHASE control to position the vector dot (representing the subcarrier on the staircase) to the burst cross on the horizontal graticule axis.
- c. Turn on the VARIABLE GAIN and use the VARIABLE control to place dots at the graticule compass rose.
- d. **CHECK** – that dots are overlaid to $\pm 1^\circ$.
- e. If more than one dot is visible, use the VARIABLE GAIN control to place the dot for the largest amplitude step to the graticule compass rose.
- f. Set the Television Signal Generator APL level for 10 and 90% average picture levels. Readjust the VARIABLE control, if necessary to place the dot back to the compass rose.
- g. **CHECK** – that dot is overlaid to $\pm 1^\circ$, at both 10 and 90% average picture levels.
- h. Disconnect the NTSC Linearity Staircase signal and remove the dual coupler.

9. CHECK CHROMINANCE VECTOR CLAMP PERFORMANCE

REQUIREMENT — Clamp stability: 1/64" (0.4 mm) or less center dot movement as the PHASE control is rotated throughout its range. Position Control range: at least 1/4" (6 mm) from the center at either limit.

- a. Connect the NTSC color bar signal to the CH-B INPUT and terminate remaining side of loop through with a 75 Ω terminator.
- b. **CHECK** – that the center dot of the vector display moves less than 1/64" (0.4 mm) as the PHASE control is rotated.
- c. **CHECK** – while varying both screwdriver position controls throughout their range, that the range of each control is greater than + and – 1/4" (6 mm) from the centered position.
- d. Return the vector display center dot to the centered position.
- e. Disconnect the Color Bar signal and terminator.

10. CHECK VARIABLE GAIN

REQUIREMENT — Input subcarrier signals between –6 dB and +14 dB (29.5 IRE and 147 IRE NTSC; 0.210 V and 1.05 V for PAL) can be adjusted to the burst amplitude.

- a. Connect the Black Burst output of the NTSC Television Signal Generator to the 1725 CH-B INPUT connector. Do not terminate this loop through connector.
- b. Press the 1725 VARIABLE push button.
- c. Adjust the 1725 VARIABLE GAIN.
- d. **CHECK** – that the burst vector can be adjusted to the 75% amplitude target.
- e. Terminate the open side of the CH B INPUT loophrough with (3) 75 Ω terminators.
- f. Adjust the 1725 VARIABLE GAIN.
- g. **CHECK** – that the burst vector can be adjusted to the compass rose.
- h. Disconnect the Black Burst signal and terminators.

11. CHECK AUTO PHASE ACCURACY

REQUIREMENT — Bursts return to targets $\pm 2^\circ$, in 1.5 seconds when AUTO is pushed.

- a. Connect the NTSC generator 75% Color Bar signal to the CH A INPUT. Terminate remaining side of the loophrough connector with a 75 Ω termination.
- b. Use the 1725 VARIABLE GAIN and PHASE control to place the tip burst vector on intersection of the graticule 0° axis and the compass rose.
- c. Push the 1725 AUTO Phase.
- d. **CHECK** – that the tip of the burst vector returns to $0^\circ \pm 2^\circ$, in 1.5 seconds.
- e. Turn off the VARIABLE GAIN.
- f. Set the burst vector to its target.
- g. Push the AUTO PHASE.
- h. **CHECK** – that the tip of the burst vector returns to $0^\circ \pm 2^\circ$, in 1.5 seconds.
- i. Disconnect the NTSC Color Bar signal.
- j. Connect the PAL generator 75% Color Bar signal to the CH A INPUT. Terminate remaining side of the loophrough connector with a 75 Ω termination.

- k. Push the AUTO PHASE.
- l. **CHECK** – that the tip of the burst vector returns to $0^\circ \pm 2^\circ$, in 1.5 seconds.
- m. Remove the PAL generator signal and 75Ω termination from the CH-A INPUT.

12. CHECK TRACE ROTATION RANGE

REQUIREMENT — Range greater than $\pm 1^\circ$ from horizontal.

- a. Connect the output of the Audio Signal Generator to pin 3 of the 1725 rear-panel XY INPUT connector. See Figure 5-9.

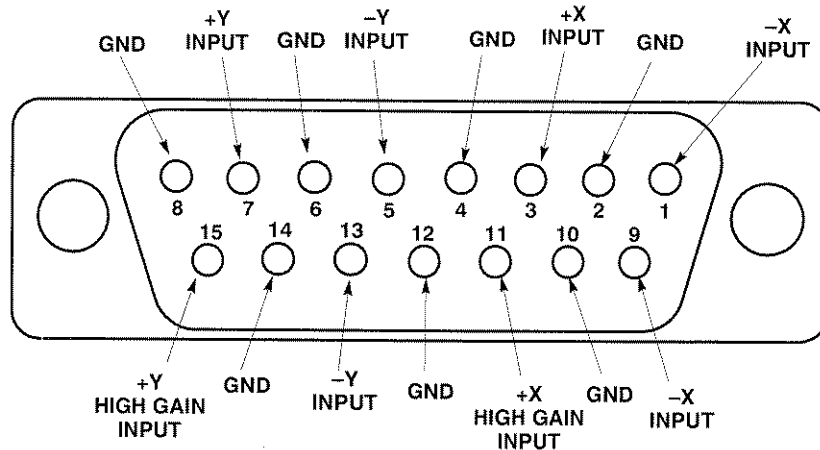

Figure 5-9: X Y INPUT connector pin functions.

- b. Adjust the Audio Signal Generator amplitude for a displayed amplitude, on the horizontal axis, that is greater than the width of the graticule compass rose.
- c. If necessary, use a small screwdriver and adjust the 1725 vertical positioning to place the trace on the horizontal axis.
- d. Use a small screwdriver to adjust the 1725 ROTATE from end to end.
- e. **CHECK** – that either end of the trace can be moved more than 1° (one-half minor division on the compass rose) either direction from horizontal.
- f. Set ROTATE so that the trace is on the horizontal axis.

13. CHECK XY INPUT PHASE MATCHING

REQUIREMENT — less than a trace width of separation at 100 kHz.

- a. Connect the Audio Signal Generator output to both pins 3 and 7. See Figure 5–9.
- b. Set the Audio Signal Generator frequency to 10 kHz and adjust its amplitude so that the trace extends between the targets (+) on the diagonal line.
- c. Set the Audio Signal Generator frequency to 100 kHz.
- d. **CHECK** – that there is a trace width or less separation in the diagonal display. See Figure 5–10.

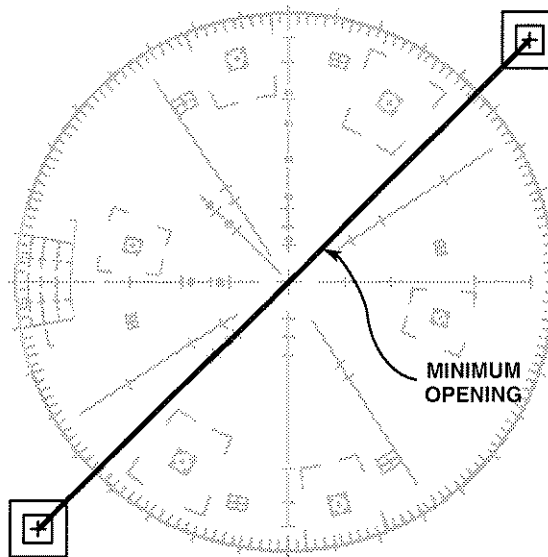

Figure 5–10: Audio frequency XY display.

14. CHECK XY FREQUENCY RESPONSE

REQUIREMENT — the –3 dB point at 200 kHz or greater in standard mode; 100 kHz or more in High Gain mode.

- a. Connect the Leveled Sine wave Generator to pin 3 of the 1725 rear-panel XY INPUT connector. See Figure 5–9.
- b. Set the Leveled Sine wave Generator frequency to 50 kHz and set its amplitude for a display the width of the compass rose.
- c. Set the Leveled Sine wave Generator frequency to 200 kHz.

- d. **CHECK** – that the display reaches the -3 dB gaps in the horizontal axis or beyond.
- e. Connect the Leveled Sine wave Generator output to pin 7 of the 1725 rear- panel XY INPUT connector.
- f. Set the Leveled Sine wave Generator to 50 kHz and set its amplitude for a display the height of the compass rose.
- g. Set the Leveled Sine wave Generator frequency to 200 kHz.
- h. **CHECK** – that the display reaches the -3 dB gaps in the vertical axis or beyond.

Perform steps i. through p. only if internal jumpers J920 and J921 (Main board) are set to High Gain mode.

- i. Connect the audio signal to pin 11 and ground pin 9 of the 1725 rear-panel XY INPUT connector. See Figure 5–9.
- j. Set the Audio Signal Generator frequency to approximately 10 kHz and adjust its amplitude for a display equal to the width of the graticule compass rose.
- k. Set the Audio Signal Generator to 100 kHz.
- l. **CHECK** – that the display reaches the -3 dB gaps in the horizontal axis or beyond.
- m. Connect the audio signal to pin 15 and ground pin 13 of the 1725 rear-panel XY INPUT connector.
- n. Set the Audio Signal Generator frequency to approximately 10 kHz and adjust its amplitude for a display equal to the height of the graticule compass rose.
- o. Set the Audio Signal Generator to 100 kHz.
- p. **CHECK** – that the display reaches the -3 dB gaps in the vertical axis or beyond.

15. CHECK RETURN LOSS

REQUIREMENT — Return loss for each input: at least 40 dB from 50 kHz to 6 MHz (instrument on or off, input in use or not, for any deflection factor setting).

- a. Connect the output from the Sine wave Generator, through a minimum loss attenuator, to the input of the Return Loss Bridge. Set the Sine wave Generator to 50 kHz. Connect the output of the Bridge to the oscilloscope and set the amplitude of the display to 500 mV_{P-P} with the

terminator removed from the Unknown arm of the Bridge. See Figure 5-11.

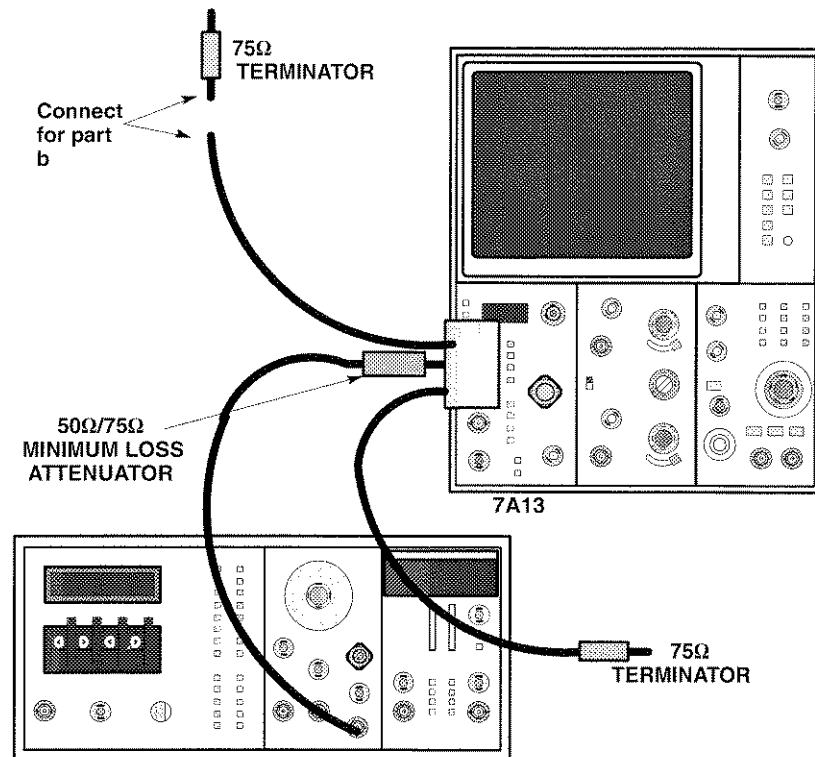

Figure 5-11: Initial equipment setup for return loss.

- b. Change the generator frequency to 6 MHz. Reconnect the terminator to the Unknown arm, set the 7A13 for 1 mV per division, and balance the Bridge. See Figure 5-11. Connect the Unknown arm to the INPUT (CH-A, CH-B, or EXT REF) of the 1725 instrument and connect the terminator to the opposite side of the loopthrough. See Figure 5-12.

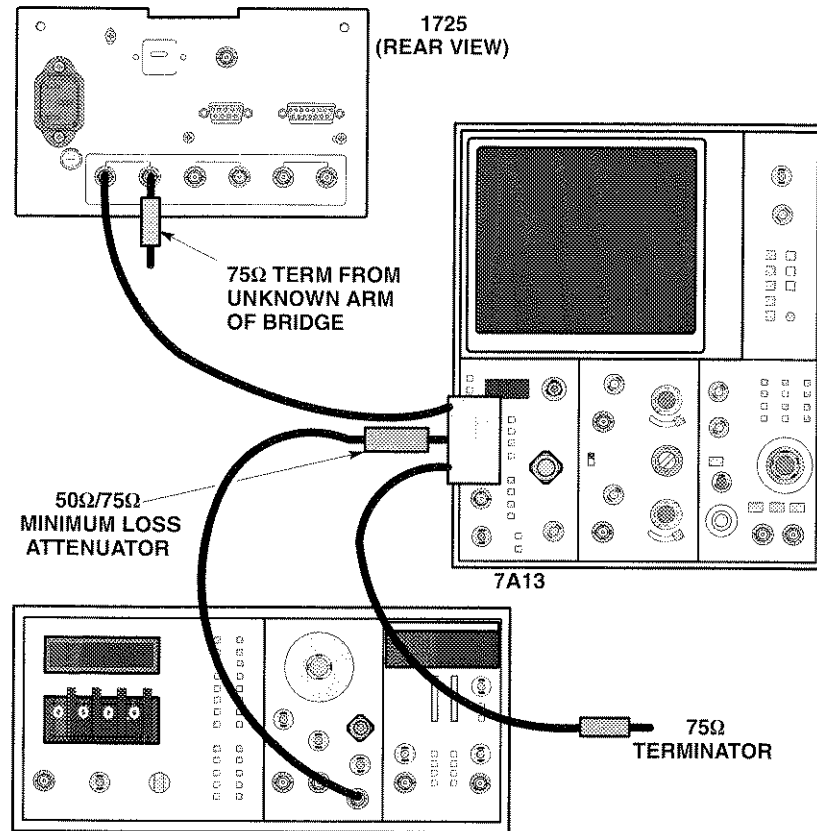

Figure 5-12: Measuring return loss of 1725 CH-A input.

- c. **CHECK** – that the return loss of the CH-A, CH-B, and EXT REF INPUTs is better than 40 dB, from 50 kHz to 6 MHz. Make this check (within this frequency range) with the instrument power on and off. Using the Nomograph supplied with the Return Loss Bridge, 40 dB converts to 5 mV on the test oscilloscope vertical scale.

End of Performance Check Procedure

ADJUSTMENT PROCEDURE

There are two Adjustment procedures. One is a short form or abbreviated procedure, intended to be used by those who are familiar with the instrument. Step numbers in the Short Form Adjustment procedure correspond directly with those of the full length procedure.

Short Form Adjustment Procedure

1. ADJUST CRT BIAS

- b. Adjust R58

2. ADJUST FOCUS AND ASTIGMATISM

- b. Adjust R11 and R49

3. ADJUST TRACE ROTATION AND GEOMETRY

- f. Adjust R45

4. ADJUST ON-BOARD REGULATED POWER SUPPLIES

- b. Adjust R272
- d. Adjust R306

5. ADJUST LOCK-IN PHASE

- c. Adjust C31
- g. Adjust C28

6. ADJUST CENTER DOT OVERLAY AND VECTOR POSITION

- d. Adjust R258
- e. Adjust R244

7. ADJUST PHASE AND GAIN MATCH

- d. Adjust C209

8. ADJUST ORTHOGONALITY

- c. Adjust R387

9. ADJUST X AND Y GAINS

- b. Adjust R207
- d. Adjust R209

10. ADJUST XY PHASING

- c. Adjust C176

11. ADJUST LOOP DC BALANCE

- e. Adjust R161

12. ADJUST QUAD PHASE AND +V BAL

- f. Adjust L10
- i. Adjust C107

13. ADJUST PAL TRANSITION

- b. Adjust C175

14. ADJUST R-Y AND B-Y GAINS

- c. Adjust R277
- d. Adjust R263

15. ADJUST NTSC 100% GAIN

- c. Adjust R371

16. ADJUST PAL GAIN

- c. Adjust R365

17. ADJUST CRT STANDARD INDICATOR

- b. Adjust R325 (Vertical) and R339

18. ADJUST AUTO LOCK IN RANGE

- e. Adjust R57

19. ADJUST LINE SELECT FOCUS

With a 1730-Series Waveform Monitor:

- e. Adjust R200

Without a 1730-Series Waveform Monitor:

- e. Adjust R200

Long Form Adjustment Procedure

Figure 5-13 shows the locations of the adjustments and test points used in this procedure.

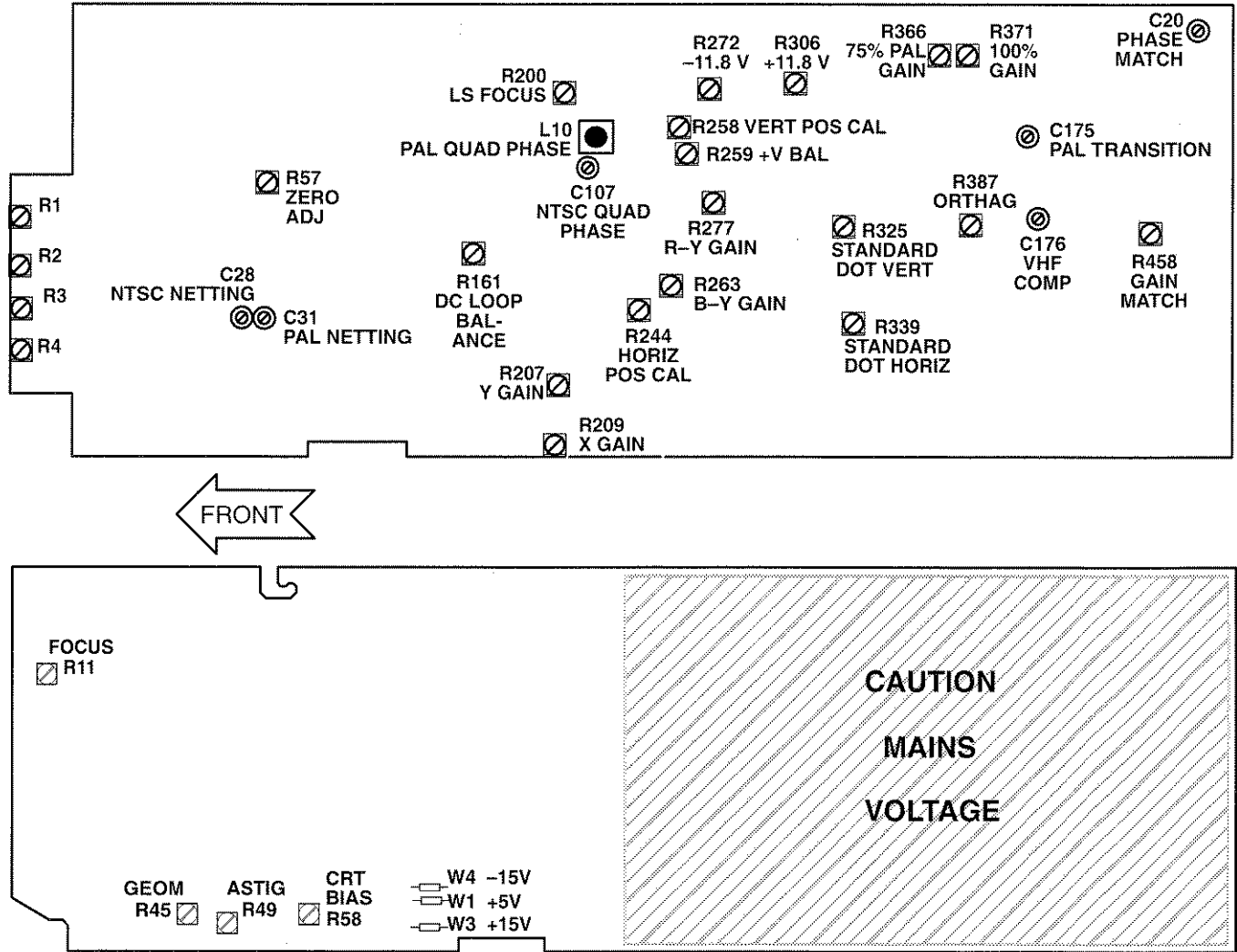

Figure 5-13: Adjustment and test point locations for the 1725 Vectorscope

SIGNAL CONNECTIONS. Connect the PAL black burst signal to the 1725 EXT REF INPUT and terminate with a 75Ω termination. Connect the PAL color bar signal to the 1725 CH-A INPUT and terminate with a 75Ω termination. Connect the NTSC color bar signal to the CH-B INPUT and terminate with a 75Ω termination. See Figure 5-14.

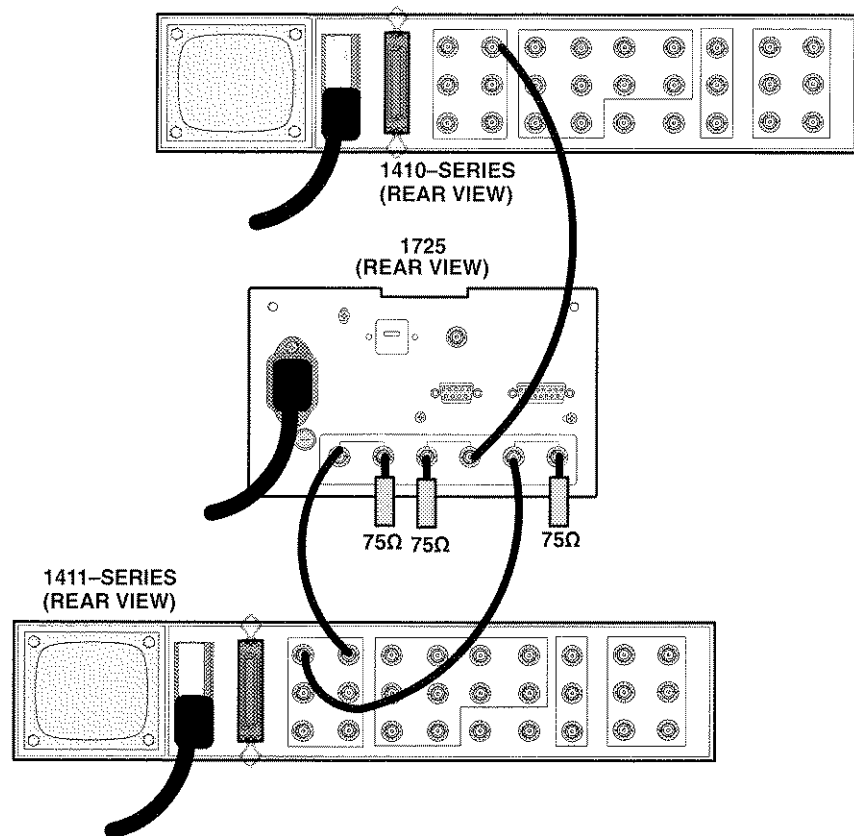

Figure 5-14: Initial equipment connections for the adjustment procedure

Connect the Audio Signal Generator to the 1725 XY INPUT. See Figure 5-1 for a diagram of how to hook up the 15-pin D-type connector to calibrate the 1725 Vectorscope. Set the Audio Signal Generator frequency to 50 kHz.

FRONT-PANEL PRESETS. Preset the 1725 front panel as shown in Table 5-2:

Table 5-2: Preliminary Control Settings

INPUT	
MODE	VECT
REF	INT
INPUT	CH-A
GAIN	
VARIABLE	Off
BARS	75%
PHASE	
+V	off

Table 5-2: Preliminary Control Settings (Cont.)

DISPLAY FOCUS	As desired
SCALE	
INTENS	
AUXILIARY	Off
POWER	ON

Allow 20 minutes of warm-up time, at normal room temperature (approximately 25° C), before making any adjustments to the instrument.

Refer to Figure 5-13 for adjustment locations.

1. ADJUST CRT BIAS

- a. Turn the intensity control fully counterclockwise.
- b. **ADJUST R58** (CRT BIAS) so that the display is just extinguished.

2. ADJUST FOCUS AND ASTIGMATISM

- a. Set the FOCUS control on the front panel so that it is approximately at the center of its rotation.
- b. **ADJUST R11** (CTR FOCUS) and **R49** (ASTIG) for a clearly-defined vector display.

3. ADJUST TRACE ROTATION AND GEOMETRY

- a. Switch the 1725 MODE to XY.
- b. Connect the Audio Signal Generator output to the X INPUT. See Figure 5-15.
- c. Adjust the Audio Generator amplitude for a line equal to the compass rose.
- d. Adjust the front-panel ROTATE screwdriver adjustment for a level trace across the crt's X axis.

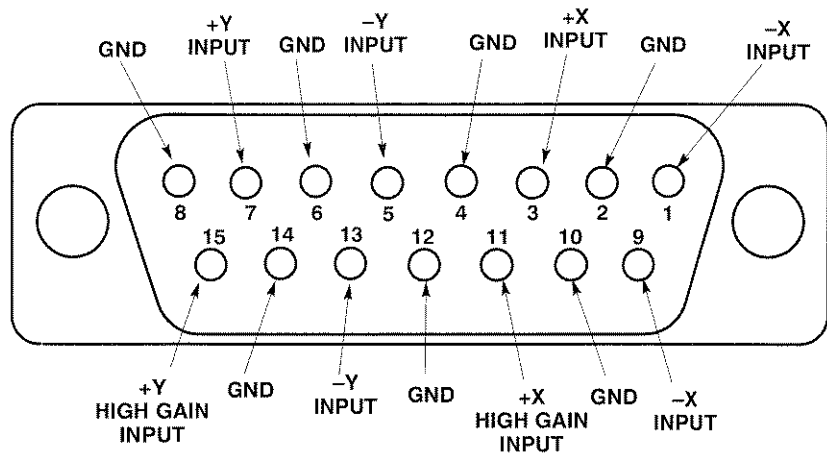

Figure 5-15: X Y INPUT connector pin functions.

- e. Disconnect the Audio Signal Generator output from the X INPUT and connect it to the Y INPUT.
- f. **ADJUST R45** (GEOM) for the straightest vertical line on the Y axis.
- g. Disconnect the Audio Generator signal from the 1725.

4. ADJUST ON-BOARD REGULATED POWER SUPPLIES

- a. Connect the voltmeter ground lead to one of the rear-panel ground lugs and the active lead to the -11.8 V test point (Emitter of U164). See Figure 5-13.
- b. **ADJUST R272** (-11.8 V ADJ) for -11.78 to -11.82 volts.
- c. Connect the voltmeter active lead to the $+11.8$ V test point (Emitter of U172). See Figure 5-13.
- d. **ADJUST R306** ($+11.8$ V ADJ) for $+11.78$ to $+11.82$ volts.

5. ADJUST LOCK-IN PHASE

- a. Set the 1725 INPUT to CH-A, MODE to VECTOR, and REF to INT.
- b. Connect the voltmeter ground lead to one of the rear-panel ground lugs, and the active lead to TP1 (test point).
- c. **ADJUST C31** (PAL Netting) for a locked display and a voltmeter reading of -6 V.

- d. Change the Television Signal Generator's subcarrier frequency by ± 10 Hz.
- e. Check for locked display.
- f. Select CH-B.
- g. **ADJUST C28** (NTSC Netting) for a locked display and a voltmeter reading of -6 V.
- h. Change the generator's subcarrier frequency by $+50$ Hz for NTSC and check for a locked display.
- i. Return the generator to subcarrier frequency.

6. ADJUST CENTER DOT OVERLAY AND VECTOR POSITION

- a. Disconnect the Television Signal Generator output from the CH-B INPUT.
- b. Adjust the 1725 front-panel horizontal and vertical position controls to center the dot at the graticule center mark.
- c. Change the 1725 MODE to BOTH.
- d. **ADJUST R258** (Vertical Position Cal) for the best dot overlay.
- e. **ADJUST R244** (Horiz Position Cal) for the best dot overlay.
- f. Change the 1725 MODE to VECT.
- g. Adjust the 1725 front-panel horizontal and vertical position controls to center the dot at the graticule center mark.

7. ADJUST PHASE AND GAIN MATCH

- a. Connect the PAL Television Signal Generator color bar output through a 75Ω feedthrough termination and dual-input connector to both the CH-A and CH-B inputs. Connect the PAL Black Burst signal to the EXT REF and terminate the remaining side of the loopthrough in 75Ω . See Figure 5-16.
- b. Set INPUT to BOTH (hold INPUT switch until both the A and B indicators light).
- c. Set the front-panel GAIN CAL to midrange.
- d. **ADJUST C209** (Phase Match) and R594 (Gain Match) for the best gain and phase match of the two vector displays.

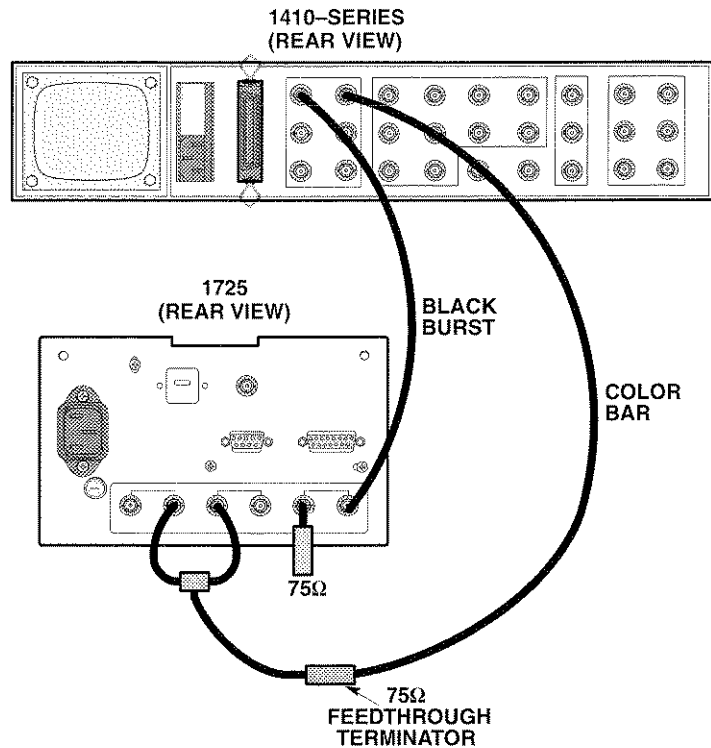

Figure 5-16: Equipment connections for CH-A/CH-B phase match adjustment

8. ADJUST ORTHOGONALITY

- a. Switch MODE to XY.
- b. Connect the Audio Signal Generator output to the Y INPUT.
- c. **ADJUST R387** (Orthog) for a straight line, parallel to the Y axis.

9. ADJUST X AND Y GAINS

- a. Set the Audio Generator to the desired output voltage between 2 V and 9 V (the 1725 is shipped at 2.4 V).
- b. **ADJUST R207** (Y Gain) for a Y axis display equal to the vertical distance between the centers of the dB boxes.
- c. Disconnect the Audio Signal Generator from the Y INPUT and connect it to the X INPUT.
- d. **ADJUST R209** (X Gain) for a display amplitude equal to the horizontal distance between the centers of the dB boxes.

10. ADJUST XY PHASING

- a. Connect the Audio Signal Generator output to both X and Y INPUTs of the 1725.
- b. Set the Audio Signal Generator frequency to 100 kHz.
- c. **ADJUST C176** (VHF Comp) for minimum opening in the diagonal trace. See Figure 5-17.

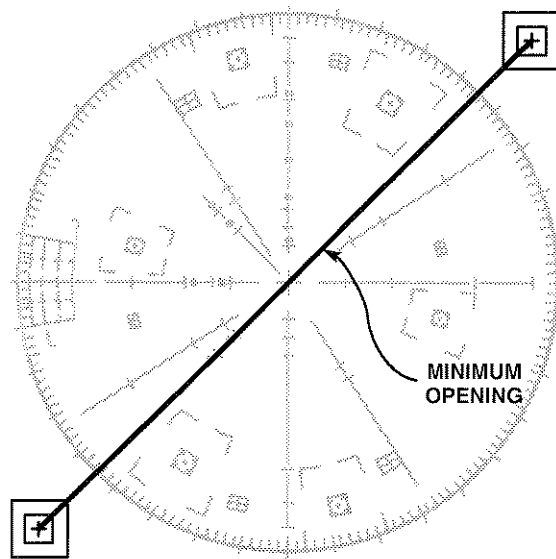

Figure 5-17: Audio frequency XY display.

11. ADJUST LOOP DC BALANCE

- a. Connect the PAL Television Signal Generator Black Burst signal to CH-A INPUT. Terminate in 75Ω .
- b. Switch INPUT to CH-A, REF to INT, and MODE to VECT.
- c. Connect the test oscilloscope X10 probe to pin 3 of U18. Set the test oscilloscope vertical to 100 mV/div, ac coupled; horizontal to $20\mu\text{s}/\text{div}$ and Internal Triggering.
- d. Ground the test oscilloscope input and position the trace to graticule center.
- e. **ADJUST R161** (DC Loop Balance) to return the test oscilloscope trace to graticule center.
- f. Position one of the PAL burst vectors on the horizontal axis.

- g. Turn ON the 1725 VAR.
- h. Rotate the VAR until the burst vector is 1/2 normal and then 1 1/2 times normal; check that the burst vector remains within 2° of the horizontal axis.
- i. If vector moves more than 2° repeat steps d. and e.
- j. Turn off the 1725 VAR.

12. ADJUST QUAD PHASE AND +V BAL

- a. Reconnect the PAL (CH-A) and NTSC (CH-B) color bar signals to the INPUTs. Terminate both inputs in 75Ω. See Figure 5-14.
- b. Select CH A INPUT.
- c. Hold the REF switch in until the TEST indicator lights.
- d. Set the front-panel GAIN CAL to midrange.
- e. Position the center dot directly under the graticule center mark (+).
- f. **ADJUST L10** (PAL Quad Phase) and R259 (+V Bal) for the best overlay of the test circles.
- g. Select INT REF and CH B.
- h. Hold the REF switch in until the TEST indicator lights.
- i. **ADJUST C107** (NTSC Quad Phase) for the best overlay of the test circles.

13. ADJUST PAL TRANSITION

- a. Select CH-A, INT REF, and 75% BARS.
- b. **ADJUST C175** (PAL Transition) for the best transition line between the green and magenta targets.

14. ADJUST R-Y AND B-Y GAINS

- a. Select CH-B (NTSC) and 75% BARS.
- b. Check to see that the center dot is directly under the graticule center mark (+).
- c. **ADJUST R277** (R-Y Gain) to place the red and cyan (R and CY) vector tips directly on their targets.

- d. **ADJUST R263** (B–Y Gain) to place the blue and yellow (B and Y) vector tips directly on their targets.

15. ADJUST NTSC 100% GAIN

- a. Select 100% Amplitude Color Bars from the PAL Television Test Signal Generator.
- b. Push the 1725 100% BARS button.
- c. **ADJUST R371** (100% Gain) the red and cyan (R and CY) vector tips directly on their targets.

16. ADJUST PAL GAIN

- a. Select CH–A INPUT (PAL) and 75% BARS.
- b. Select 75% Amplitude Color Bars from the PAL Television Test Signal Generator.
- c. **ADJUST R365** (PAL 75% Gain) to place the vector tips on their target.
- d. Select 100% Amplitude Color Bars.
- e. Push the 1725 100% BARS button.
- f. Check that the PAL vector tips within their inner targets.

17. ADJUST CRT STANDARD INDICATOR

- a. Select CH–B.
- b. **ADJUST R325** (Vertical) and **R339** (Horizontal) Indicator positions to place the indicator dot in the middle of the NTSC indicator box.
- c. Select CH–A (PAL input signal) and check that the indicator dot is in the PAL indicator box.

18. ADJUST AUTO LOCK IN RANGE

- a. Select CH–B (NTSC input signal).
- b. Use the front-panel Horizontal and Vertical positioning controls to place the center dot directly at graticule center.
- c. Use the VARIABLE GAIN and PHASE control to position the burst vector tip directly on the horizontal axis at 1/2 burst amplitude. See Figure 5–18.

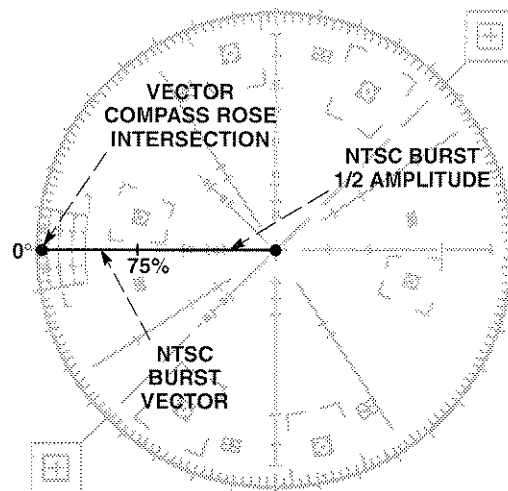

Figure 5-18: Adjustment point for auto phase lock

- d. Press 1725 AUTO PHASE button and allow the display to lockup. (≤ 1.5 seconds.)
- e. **ADJUST R57** (Zero Adjust) to position the burst vector tip back to the 0° compass rose intersection.
- f. Repeat steps d. and e. until the vector tip remains on target when the AUTO PHASE button is pushed.
- g. Set the VARIABLE GAIN to place the burst vector tip on the compass rose. See Figure 5-18.
- h. Press 1725 AUTO PHASE button and check that the burst tip is within $\pm 2^\circ$ of the horizontal axis.
- i. Turn off 1725 VARIABLE GAIN and display the NTSC 75% color bar signal.
- j. Push the AUTO PHASE and check that burst returns to target $\pm 2^\circ$.
- k. Select CH-A to display the PAL color bar signal.
- l. Push AUTO PHASE and check that the bursts return to the graticule burst targets $\pm 2^\circ$.
- m. Turn on the VARIABLE GAIN and use the VARIABLE GAIN and PHASE controls to position the burst vector tips directly on the compass at the point where the extended burst vectors ($\pm 45^\circ$) intersect the compass rose.
- n. Push AUTO PHASE and check that the bursts return to the graticule compass rose at the extended burst targets $\pm 2^\circ$.

- o. Push the AUTO PHASE and check that burst returns to target $\pm 2^\circ$.
- p. Turn off 1725 VARIABLE GAIN and display the PAL 75% color bar signal.
- q. Push the AUTO PHASE and check that burst returns to target $\pm 2^\circ$.
- r. Repeat steps b. and c. until the vector tip remains on target when the AUTO PHASE button is pushed.

19. ADJUST LINE SELECT FOCUS

With a 1730-Series Waveform Monitor:

- a. Connect an Auxiliary cable between the 1725 and a 1730-Series of the same color standard that is to be displayed.
- b. loop through connect the color bar signal to both the waveform monitor and the 1725.
- c. Set the 1730-Series Waveform Monitor for line select and display one line from the active part of the field (after the vertical interval).
- d. Push the 1725 AUXILIARY button.
- e. **ADJUST R200** (LS Focus) for the best 1725 display.

Without a 1730-Series Waveform Monitor:

- f. Connect the output of the Function Generator to pin 7 of the 1725 rear-panel AUXILIARY connector.
- g. Set the Function Generator for a narrow, negative-going, 10 V, 1 kHz pulse.
- h. Set the 1725 for VECT and adjust INTENS and FOCUS for the best display.
- i. Push the 1725 AUXILIARY button.
- j. **ADJUST R200** (LS Focus) for the best 1725 display.

