

Instructions



A6302 & A6302XL 20 Ampere AC/DC Current Probes

070-3905-04

Warning

The servicing instructions are for use by qualified personnel only. To avoid personal injury, do not perform any servicing unless you are qualified to do so. Refer to all safety summaries prior to performing service.



Copyright © Tektronix, Inc. All rights reserved.

Tektronix products are covered by U.S. and foreign patents, issued and pending. Information in this publication supercedes that in all previously published material. Specifications and price change privileges reserved.

Printed in the U.S.A.

Tektronix, Inc., P.O. Box 1000, Wilsonville, OR 97070-1000

TEKTRONIX and TEK are registered trademarks of Tektronix, Inc.

WARRANTY

Tektronix warrants that the products that it manufactures and sells will be free from defects in materials and workmanship for a period of one (1) year from the date of shipment. If a product proves defective during this warranty period, Tektronix, at its option, either will repair the defective product without charge for parts and labor, or will provide a replacement in exchange for the defective product.

In order to obtain service under this warranty, Customer must notify Tektronix of the defect before the expiration of the warranty period and make suitable arrangements for the performance of service. Customer shall be responsible for packaging and shipping the defective product to the service center designated by Tektronix, with shipping charges prepaid. Tektronix shall pay for the return of the product to Customer if the shipment is to a location within the country in which the Tektronix service center is located. Customer shall be responsible for paying all shipping charges, duties, taxes, and any other charges for products returned to any other locations.

This warranty shall not apply to any defect, failure or damage caused by improper use or improper or inadequate maintenance and care. Tektronix shall not be obligated to furnish service under this warranty a) to repair damage resulting from attempts by personnel other than Tektronix representatives to install, repair or service the product; b) to repair damage resulting from improper use or connection to incompatible equipment; c) to repair any damage or malfunction caused by the use of non-Tektronix supplies; or d) to service a product that has been modified or integrated with other products when the effect of such modification or integration increases the time or difficulty of servicing the product.

THIS WARRANTY IS GIVEN BY TEKTRONIX IN LIEU OF ANY OTHER WARRANTIES, EXPRESS OR IMPLIED. TEKTRONIX AND ITS VENDORS DISCLAIM ANY IMPLIED WARRANTIES OF MERCHANTABILITY OR FITNESS FOR A PARTICULAR PURPOSE. TEKTRONIX' RESPONSIBILITY TO REPAIR OR REPLACE DEFECTIVE PRODUCTS IS THE SOLE AND EXCLUSIVE REMEDY PROVIDED TO THE CUSTOMER FOR BREACH OF THIS WARRANTY. TEKTRONIX AND ITS VENDORS WILL NOT BE LIABLE FOR ANY INDIRECT, SPECIAL, INCIDENTAL, OR CONSEQUENTIAL DAMAGES IRRESPECTIVE OF WHETHER TEKTRONIX OR THE VENDOR HAS ADVANCE NOTICE OF THE POSSIBILITY OF SUCH DAMAGES.

Service Assurance

If you have not already purchased Service Assurance for this product, you may do so at any time during the product's warranty period. Service Assurance provides Repair Protection and Calibration Services to meet your needs.

Repair Protection extends priority repair services beyond the product's warranty period; you may purchase up to three years of Repair Protection.

Calibration Services provide annual calibration of your product, standards compliance and required audit documentation, recall assurance, and reminder notification of scheduled calibration. Coverage begins upon registration; you may purchase up to five years of Calibration Services.

Service Assurance Advantages

- Priced well below the cost of a single repair or calibration
- Avoid delays for service by eliminating the need for separate purchase authorizations from your company
- Eliminates unexpected service expenses

For Information and Ordering

For more information or to order Service Assurance, contact your Tektronix representative and provide the information below. Service Assurance may not be available in locations outside the United States of America.

| | |
|--------------------------|--|
| Name | VISA or Master Card number and expiration |
| Company | date or purchase order number |
| Address | Repair Protection (1,2, or 3 years) |
| City, State, Postal code | Calibration Services (1,2,3,4, or 5 years) |
| Country | Instrument model and serial number |
| Phone | Instrument purchase date |

Table of Contents

| | |
|--|------------|
| General Safety Summary | iii |
| Getting Started | 1 |
| Product Description | 1 |
| Probe Installation | 2 |
| Operating the Current Probe Slide | 3 |
| Degaussing and Autobalancing the Current Probe | 4 |
| Probe Trim Adjust for Gain Accuracy (AM 503B and AM 5030 Only) | 4 |
| Maximum Current Limits | 5 |
| Specifications | 8 |
| Maintenance | 12 |
| Cleaning | 12 |
| Disassembly Instructions | 12 |
| Obtaining Replacement Parts | 17 |
| Preparation for Shipment | 17 |
| Replaceable Parts | 18 |
| Parts Ordering Information | 18 |
| Using the Replaceable Parts List | 18 |

List of Figures

| | |
|--|-----------|
| Figure 1: Connecting a current probe to the current probe amplifier | 2 |
| Figure 2: Operating the probe slide | 3 |
| Figure 3: Applying the amp-second product rule | 6 |
| Figure 4: A6302 and A6302XL specified operating area | 9 |
| Figure 5: A6302 and A6302XL frequency derating curve for maximum input current | 9 |
| Figure 6: A6302 and A6302XL insertion impedance curve | 10 |
| Figure 7: Probe jaw dimensions (nominal) | 10 |
| Figure 8: Removing the strain relief boot | 13 |
| Figure 9: Removing the top half of the probe | 14 |
| Figure 10: Removing the probe slide | 14 |
| Figure 11: Removing the current transformer and cable assembly of the A6302 probe | 15 |
| Figure 12: Removing the current transformer of the A6302XL probe | 16 |
| Figure 13: A6302 exploded view | 21 |
| Figure 14: A6302XL exploded view | 23 |

List of Tables

| | |
|--|-----------|
| Table 1: Warranted A6302 and A6302XL specifications | 8 |
| Table 2: Electrical characteristics | 8 |
| Table 3: Mechanical characteristics | 10 |
| Table 4: Environmental characteristics | 11 |
| Table 5: Certifications and compliances | 11 |

General Safety Summary

Review the following safety precautions to avoid injury and prevent damage to this product or any products connected to it.

Only qualified personnel should perform service procedures.

Injury Precautions

Avoid Electric Overload. To avoid electric shock or fire hazard, do not apply a voltage to a terminal that is outside the range specified for that terminal.

Avoid Electric Shock. To avoid injury or loss of life, do not connect or disconnect probes or test leads while they are connected to a voltage source.

Ground the Product. This product is indirectly grounded through the grounding conductor of the mainframe power cord. To avoid electric shock, the grounding conductor must be connected to earth ground. Before making connections to the input or output terminals of the product, ensure that the product is properly grounded.

Do Not Operate in Wet/Damp Conditions. To avoid electric shock, do not operate this product in wet or damp conditions.

Do Not Operate in an Explosive Atmosphere. To avoid injury or fire hazard, do not operate this product in an explosive atmosphere.

Product Damage Precautions

Do Not Operate With Suspected Failures. If you suspect there is damage to this product, have it inspected by qualified service personnel.

Do Not Immerse in Liquids. Clean the probe using only a damp cloth. Refer to cleaning instructions.

Symbols and Terms

Terms in this Manual. These terms may appear in this manual:



WARNING. *Warning statements identify conditions or practices that could result in injury or loss of life.*



CAUTION. *Caution statements identify conditions or practices that could result in damage to this product or other property.*

Terms on the Product. These terms may appear on the product:

DANGER indicates an injury hazard immediately accessible as you read the marking.

WARNING indicates an injury hazard not immediately accessible as you read the marking.

CAUTION indicates a hazard to property including the product.

Symbols on the Product. The following symbols may appear on the product:



DANGER
High Voltage



Protective Ground
(Earth) Terminal



ATTENTION
Refer to Manual



Double
Insulated

**Certifications and
Compliances**

Refer to the specifications section for a listing of certifications and compliances that apply to this product.

Preface

This instruction manual supports the operation and maintenance of the A6302 and A6302XL current probes with any of the AM 503 series current probe amplifiers.

You can find additional documentation supporting the operation and maintenance of the AM 503 series amplifiers in the following manuals:

- *AM 503 Instruction Manual (070-2052-XX)*
- *AM 503S (AM 503A) User Manual (070-8170-XX)*
- *AM 503S (AM 503A) Service Manual (070-8174-XX)*
- *AM 503B & AM 5030 Instruction Manual (070-8766-XX)*

Getting Started

This section explains how to install and operate the A6302 and A6302XL current probes.

Product Description

The A6302 is a DC to 50 MHz current probe designed for use with the AM 503 family of current probe amplifiers and with the 11A16 plug-in. With the AM 503 family, the A6302 can measure currents to 20 A (DC + peak AC), and up to 50 A peak current (while not exceeding the amp-second rating). With the 11A16 plug-in, the A6302 can measure currents to 10.5 A.

The A6302XL is an extended length cable version of the A6302. It offers the same current range as the A6302 with a diminished frequency range of DC to 17 MHz. The A6302XL can only be used with the AM 503B and AM 5030, and will not be recognized by other current probe amplifiers.

The probe performance specifications, verification, and adjustment are unique to the amplifier that the probe is plugged into. Please refer to the amplifier documentation for specifications and verification procedures.

Probe Installation

To connect the current probe to the amplifier input connector, align the tab of the probe connector with the slot in the amplifier input connector as shown in Figure 1(a). Align the dot on the probe connector with the groove opening of the input connector as shown in Figure 1(b). Push the probe connector in while twisting the barrel clockwise to lock the connector.



CAUTION. Handle the current probe with care. Do not drop the probe or subject it to impact, or the core may crack. Do not connect or disconnect the current probe while the probe is clamped around a live conductor or while the amplifier is powered on, or the probe may suffer electrical damage.

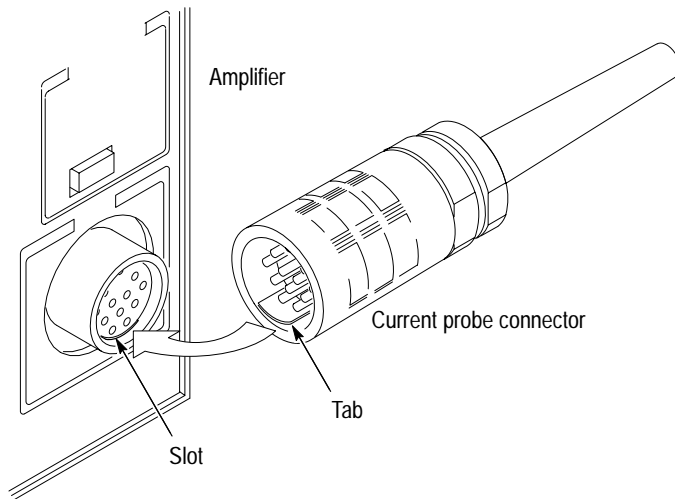

(a) Align the tab with the connector slot

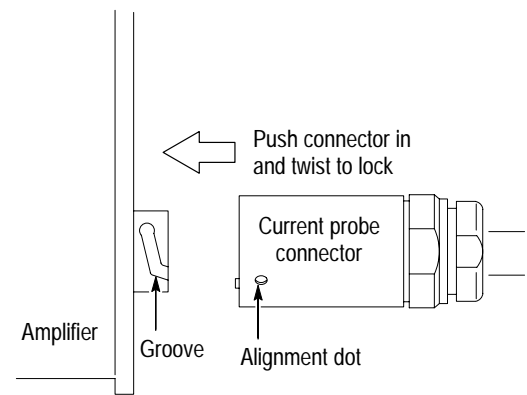

(b) Insert the connector into the amplifier

Figure 1: Connecting a current probe to the current probe amplifier

Operating the Current Probe Slide

The current probe has a slide mechanism that opens and closes the probe jaw. This allows you to clamp the probe around a conductor under test. The slide must be locked to accurately measure current or to degauss the probe. If a probe is unlocked, the PROBE OPEN indicator on the amplifier lights.



WARNING. When the probe slides are open, the exposed ferrite core pieces are not insulated. To avoid injury or equipment damage, remove power from an uninsulated wire before clamping the current probe around it. Also, never disconnect the probe from the amplifier when the probe is connected to a live conductor.

Figure 2 illustrates the slide operation of the probe. To open the probe, pull the slide back until the jaw is open. To lock the probe, push the slide forward until the detent snaps into place.

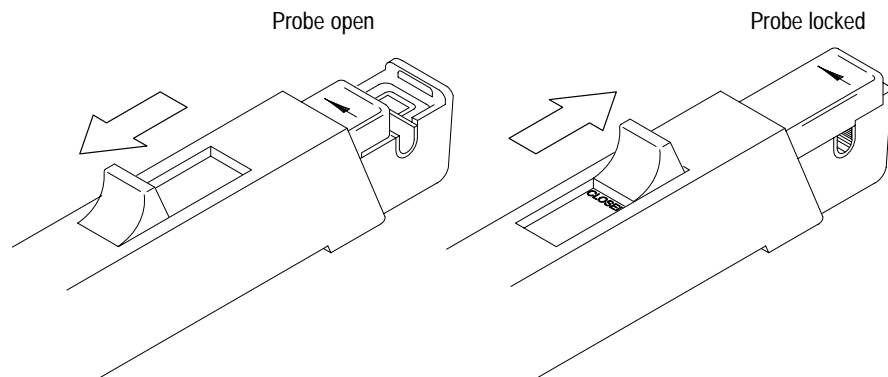

Figure 2: Operating the probe slide

Degaussing and Autobalancing the Current Probe

Degaussing the probe removes any residual magnetization from the probe core. Such residual magnetization can induce measurement error. Autobalancing removes unwanted DC offsets in the amplifier circuitry.

Failure to degauss the probe is a leading cause of measurement errors. To maintain measurement accuracy, degauss your probe in each of these cases:

- After turning on the amplifier and allowing a 20-minute warm-up period
- Before connecting the probe to a conductor, or changing conductors under test
- Whenever an overload condition occurs
- Whenever the probe is subjected to a strong external magnetic field
- Periodically during normal use

Degauss and autobalance the current probe as follows

1. Verify that the current probe is connected to the amplifier.
2. Remove the current probe from the conductor under test.
3. Lock the probe slide closed (see Figure 2).
4. Press the amplifier **PROBE DEGAUSS AUTOBALANCE** button.

***NOTE.** The degauss procedure will fail if the amplifier is not properly connected to a 50 Ω termination impedance.*

After you have completed the oscilloscope adjustments and the degauss/autobalance procedure, your system is ready to measure current.

Probe Trim Adjust for Gain Accuracy (AM 503B and AM 5030 Only)

After the PROBE DEGAUSS AUTOBALANCE routine has been run, the probe and amplifier system will meet all published specifications; however, if you want to improve the tolerance of the system gain accuracy, or to intentionally offset the gain accuracy to make up for total system errors, the probe trim adjust routine may be performed.

Probe trim adjust is a multiplicative factor that you can use to adjust the gain of the current amplifier system. You can set this multiplier in increments of 0.001 from 0.750 through 1.250. Probe trim adjust is used for an optional calibration of

some current probes. If you are not performing such an adjustment, leave probe trim adjust to the factory-default of unity gain (1.000).

To set probe trim adjust, press and hold the 20MHz BW LIMIT button while pressing and releasing the COUPLING button. Use the \uparrow and \downarrow buttons to adjust the setting that is displayed in the CURRENT/DIVISION display. When finished, press either the 20MHz BW LIMIT or COUPLING button to restore normal operation.

The display shows the last three significant digits of the display adjust setting; the leading 0. or 1. are omitted. If the first digit displayed is 7, 8, or 9, then the leading digit must be 0. If the first digit displayed is 0, 1, or 2, then the leading digit must be 1.

Maximum Current Limits

Current probes have three maximum current ratings: continuous, pulsed, and Ampere-second product. Exceeding any of these ratings can saturate the probe core and cause measurement errors. The section titled *Specifications* on page 8 lists the maximum current ratings of the probe.

- Maximum Continuous Current refers to the maximum current that can be continuously measured at DC or at a specified AC frequency. The maximum continuous current value is derated with frequency; as the frequency increases, the maximum continuous current rating decreases.
- Maximum Pulsed Current refers to the maximum peak value of pulsed current the probe can accurately measure, regardless of how short (within bandwidth limitations) the pulse duration.
- Ampere-Second Product defines the maximum width of pulsed current that you can measure when the pulse amplitude is between the maximum continuous and maximum pulsed current specifications. The maximum continuous specification itself varies by frequency.

NOTE. Always degauss the probe after measuring a current that exceeds the maximum continuous current, maximum pulsed current, or Ampere-second product rating of the probe. Exceeding these ratings can magnetize the probe and cause measurement errors.

To determine if your measurement exceeds the Ampere-second product, perform either Procedure A or Procedure B:

Procedure A To determine the maximum allowable pulse width, measure the peak current of the pulse (see Figure 3a). Divide the Ampere-second (or Ampere-microsecond) specification of your probe by the measured peak current of the pulse. The quotient is the maximum allowable pulse width; the pulse width at the 50% point of the measured signal must be less than this value.

For example, the A6302 current probe has a maximum Ampere-second product of $100 \text{ A} \cdot \mu\text{s}$. If a pulse measured with an A6302 probe has a peak current of 40 A, the maximum allowable pulse width would be $100 \text{ A} \cdot \mu\text{s}$ divided by 40 A, or $2.5 \mu\text{s}$.

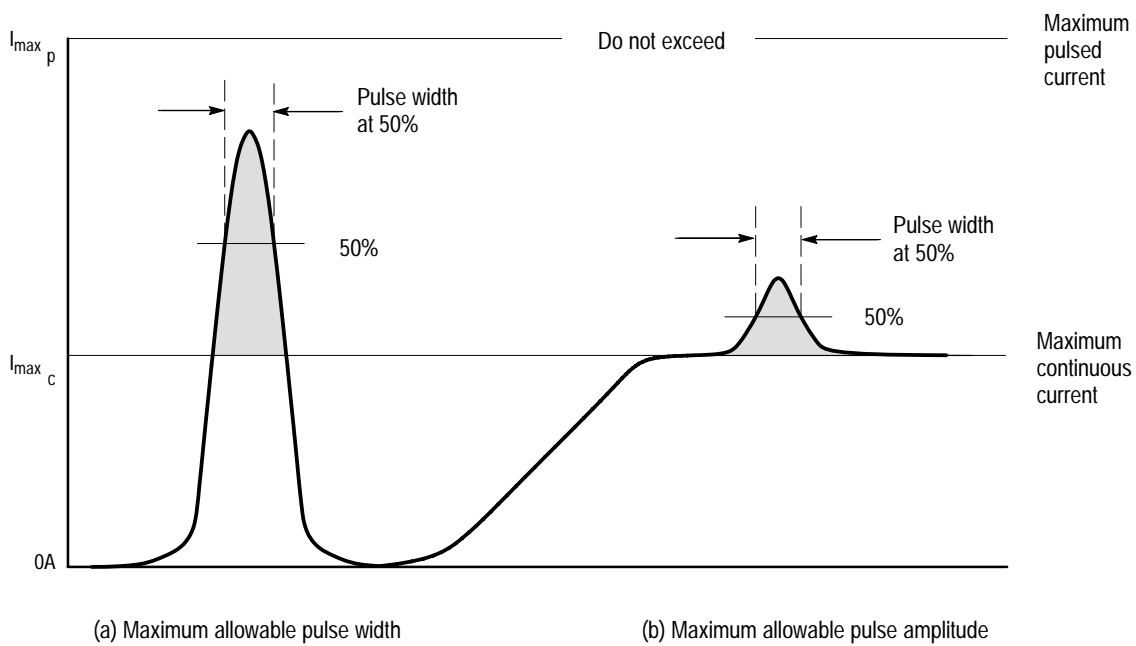

Figure 3: Applying the amp-second product rule

Procedure B To determine the maximum allowable pulse amplitude, measure the pulse width at the 50% points (see Figure 3b). Divide the Ampere-second (or Ampere-microsecond) specification of your probe by the pulse width. The quotient is the maximum allowable current; the peak amplitude of the measured pulse must be less than this value.

For example, the A6302 current probe has a maximum Ampere-second product of $100 \text{ A} \cdot \mu\text{s}$. If a pulse measured with an A6302 probe has a width of $3 \mu\text{s}$, the maximum allowable peak current would be $100 \text{ A} \cdot \mu\text{s}$ divided by $3 \mu\text{s}$, or 33.3 A .

Specifications

This section lists the specifications, characteristics, certifications, and compliances for the A6302 and A6302XL current probes.

Warranted specifications, Table 1, are guaranteed performance specifications unless specifically designated as typical or nominal.

Table 1: Warranted A6302 and A6302XL specifications

| Parameter | Installed current probe | |
|------------------------|---------------------------------------|---------------------------------------|
| | A6302 | A6302XL (AM 503B/AM5030 only) |
| Bandwidth | DC to 50 MHz, -3 dB | DC to 17 MHz, -3 dB |
| Rise time, 10% to 90% | $\leq 7 \text{ ns}^1$ | $\leq 20 \text{ ns}$ |
| Aberrations (typical) | $7\%_{\text{pk-pk}}^1$ | $10\%_{\text{pk-pk}}$ |
| DC gain accuracy | $\leq 3\%^2$ | $\leq 3\%^2$ |
| System noise (typical) | $\leq 250 \mu\text{A}_{\text{RMS}}^3$ | $\leq 250 \mu\text{A}_{\text{RMS}}^3$ |

- ¹ You can optimize the pulse response by adjusting R364 (HF COMP) located inside the AM 503 amplifier. Refer to the AM 503 Instruction Manual (070-2052-XX) for instructions on how to access this adjustment.
- ² On the AM 503B and AM 5030, the DC gain accuracy is correctable to $< 0.2\%$ when using the AM 503B and AM 5030 probe trim procedure described on page 4.
- ³ The bandwidth of the measurement instrument must be \leq limited to 200 MHz.

Mechanical, electrical, and environmental characteristics for the A6302 and A6302XL current probes are listed in Tables 2 through 4 and Figures 4 through 7.

Table 2: Electrical characteristics

| | |
|-----------------------------------|--|
| Frequency derating | 2.5 A at 10 MHz |
| Maximum bare wire working voltage | $300 V_{\text{RMS}}$, CAT I (see Table 5) |
| Maximum continuous current | AM 503B and AM 5030: 20 A (DC + peak AC) 11A16: 10.5 A (DC + peak AC) |
| Maximum pulsed current | 50A |
| Amp · second product | $1 \times 10^{-4} \text{ A} \cdot \text{s}$ (100 A · μs) |
| Insertion impedance | 0.1 Ω at 1 MHz 0.5 Ω at 50 MHz |

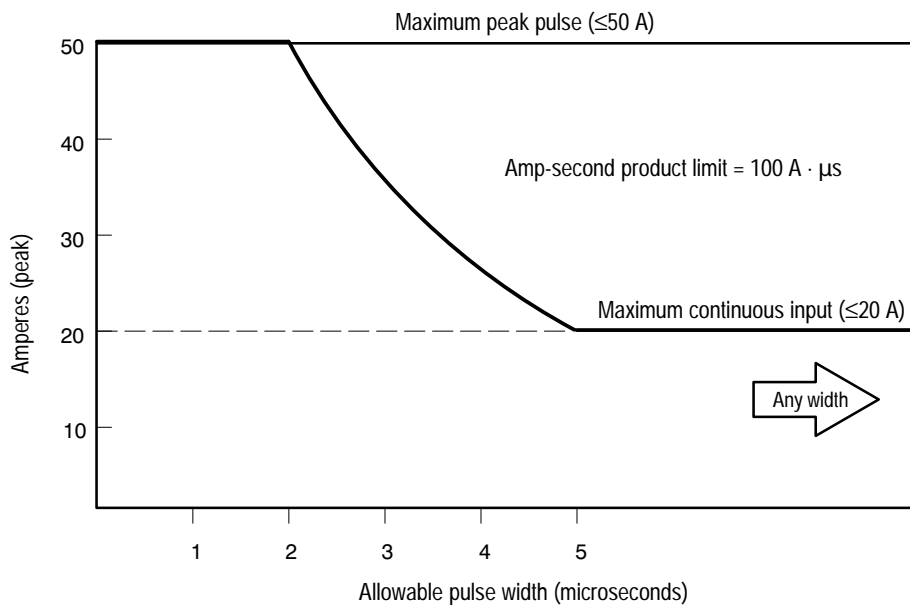

Figure 4: A6302 and A6302XL specified operating area

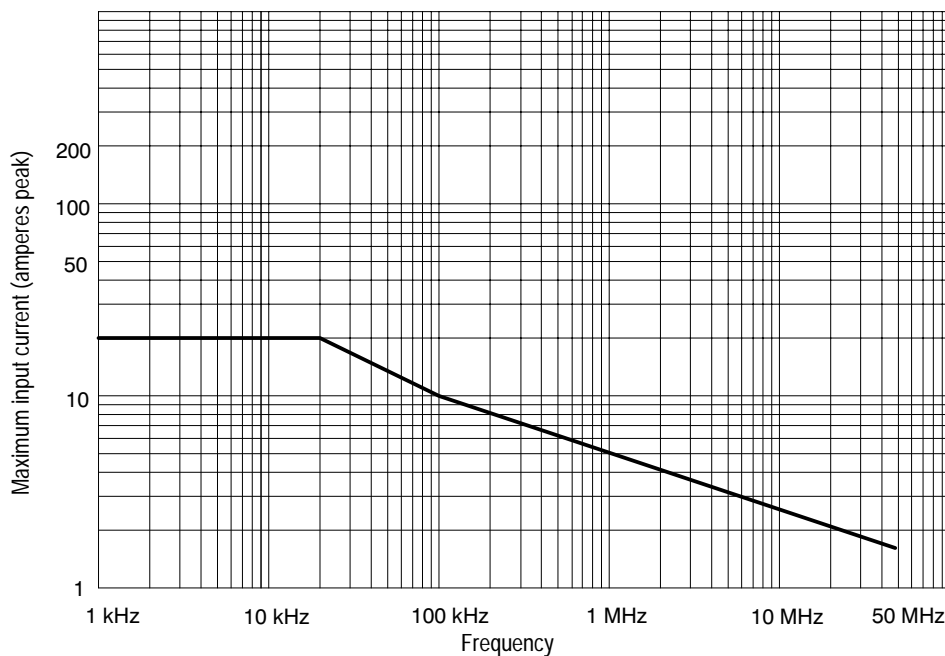

Figure 5: A6302 and A6302XL frequency derating curve for maximum input current

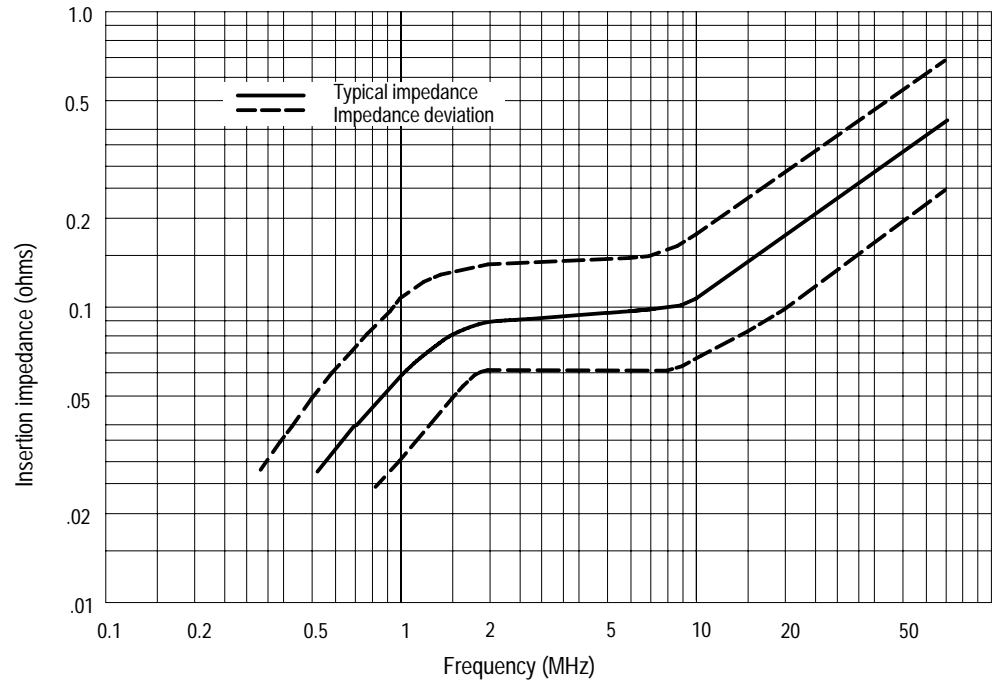

Figure 6: A6302 and A6302XL insertion impedance curve

Table 3: Mechanical characteristics

| | |
|------------------|---|
| Probe dimensions | Length: 20 cm (7.77 inches) Width: 1.6 cm (0.625 inches) Height: 3.2 cm (1.25 inches) |
| Cable length | A6302: 2 m (6.6 feet) A6302XL: 8 m (26.25 feet) |
| Weight | A6302: 255 g (0.56 lbs) A6302XL: 726 g (1.6 lbs) |

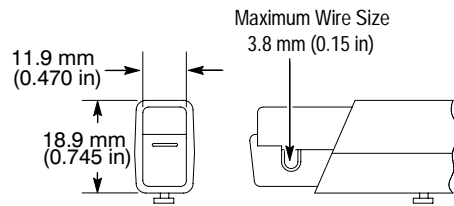

Figure 7: Probe jaw dimensions (nominal)

Table 4: Environmental characteristics

| | |
|-----------------------|--|
| Operating temperature | 0° C to 50° C |
| Storage temperature | -40° C to 75° C |
| Humidity | |
| Nonoperating | 30° C to 60° C at 90 to 95% RH |
| Operating | 30° C to 50° C at 90 to 95% RH |
| Transportation | Qualifies under National Safe Transit Procedure 1A, category II, 36 in. drop |
| Mechanical shock | 500 g. Half sine. Three shocks on three axes of the probe for 1 ms duration. Total of 9 shocks |
| Vibration | 0.025 in. pk-pk displacement. 10 – 50 Hz in 1min. cycles. Hold 9 min. at any major resonance, or if none, at 55 Hz. Total time, 54 min |
| Random vibration | |
| Operating | 0.31 g _{RMS} , 5 to 500 Hz, 10 minutes on each axis Tektronix Std. 062-2858-00, Rev. B, Class 3 |

Table 5 lists the product certifications and compliances.

Table 5: Certifications and compliances

| | | |
|------------------------------|---|---|
| EC Declaration of Conformity | Meets intent of Low Voltage Directive 73/23/EEC for Product Safety. Compliance was demonstrated to the following specification as listed in the Official Journal of the European Communities: | |
| | Low Voltage Directive 73/23/EEC as amended by 93/68/EEC: | |
| | EN 61010-1 | Safety requirements for electrical equipment for measurement, control, and laboratory use |
| | EN 61010-2-032:1994 | Particular requirements for hand-held current clamps for electrical measurement and test |
| Certifications | Underwriters Laboratories certified to Standard UL3111-1 and CSA/CAN C22.2 No. 1010.1 for Electrical and Electronic Measuring and Testing Equipment. | |
| | Underwriters Laboratories certified to Standard IEC1010-2-032, Particular requirements for hand-held current clamps for electrical measurement and test. | |
| Overvoltage category | Category: | Examples of Products in this Category: |
| | CAT III | Distribution-level mains, fixed installation |
| | CAT II | Local-level mains, appliances, portable equipment |
| | CAT I | Signal levels in special equipment or parts of equipment, telecommunications, electronics |
| Pollution degree 2 | Do not operate in environments where conductive pollutants may be present. | |

Maintenance

This section explains how to clean the A6302 and A6302XL current probes and, if necessary, disassemble a probe for maintenance or repair. Also included are instructions for preparing a probe for shipment.



WARNING. *Probe disassembly should only be performed by qualified service personnel.*

Cleaning

To clean the probe body, use a soft cloth dampened in a solution of mild detergent and water. To clean the core, open the jaw and clean the exposed core surfaces with a cotton swap dampened with isopropyl alcohol (isopropanol) or ethyl alcohol (fotocol or ethanol).

Do not lubricate the jaws mating surfaces. Any lubricant between the core pieces should be removed with a recommended solvent.

Do not use chemicals containing benzine, benzene, toluene, xylene, acetone, or similar solvents.

Do not use a petroleum based lubricant on the plastic. If the plastic slide assembly requires lubrication, use a silicone based grease sparingly.

Do not immerse the probe in liquids or use abrasive cleaners.

Disassembly Instructions

The following procedures explain how to disassemble the probe body and replace the current transformer.



WARNING. *Probe disassembly should only be performed by qualified service personnel.*

Disassembling the Probe Body

Disassemble the A6302 or A6302XL probe body as follows:

1. Remove the two screws from the bottom of the probe and pull the strain relief boot back as shown in Figure 8.

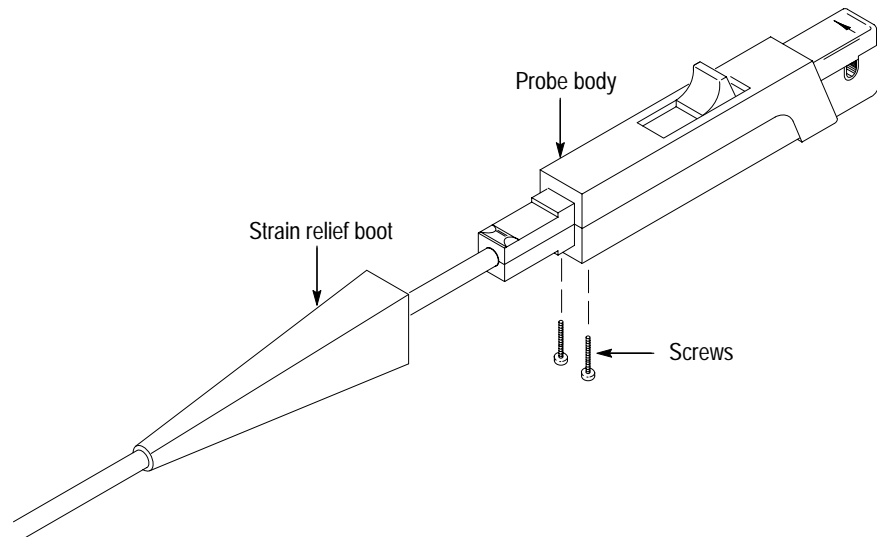

Figure 8: Removing the strain relief boot

2. Move the probe slide assembly to the open position.

NOTE. *The probe slide contains a tiny metal ball. In step 3, be careful not to lose the ball by accidentally letting it fall out.*

3. Hold the probe in a top-up horizontal position and slide the top half of the probe body off as shown in Figure 9.
4. Remove the metal ball.
5. Turn the probe upside down, push the slide back slightly, and remove the slide (see Figure 10).

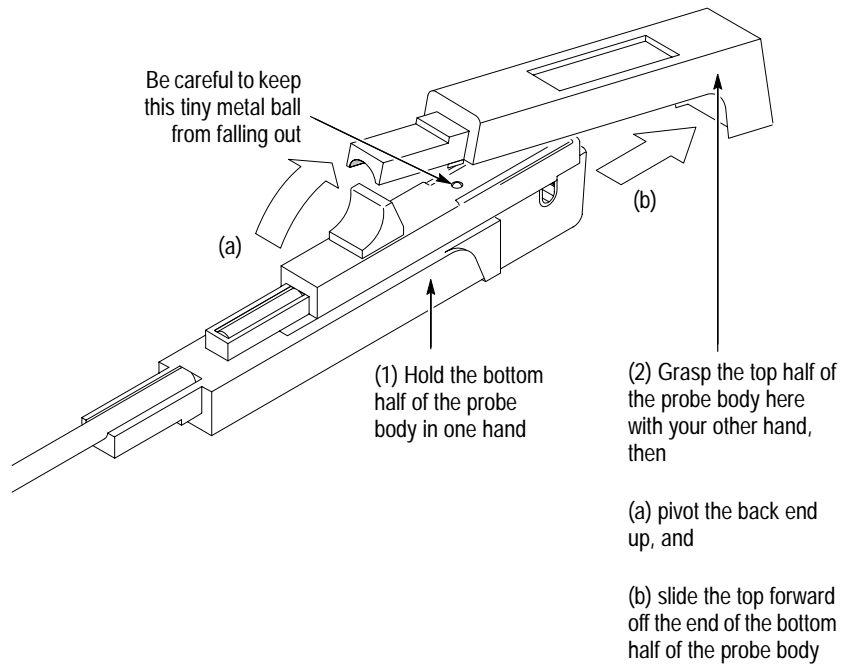

Figure 9: Removing the top half of the probe

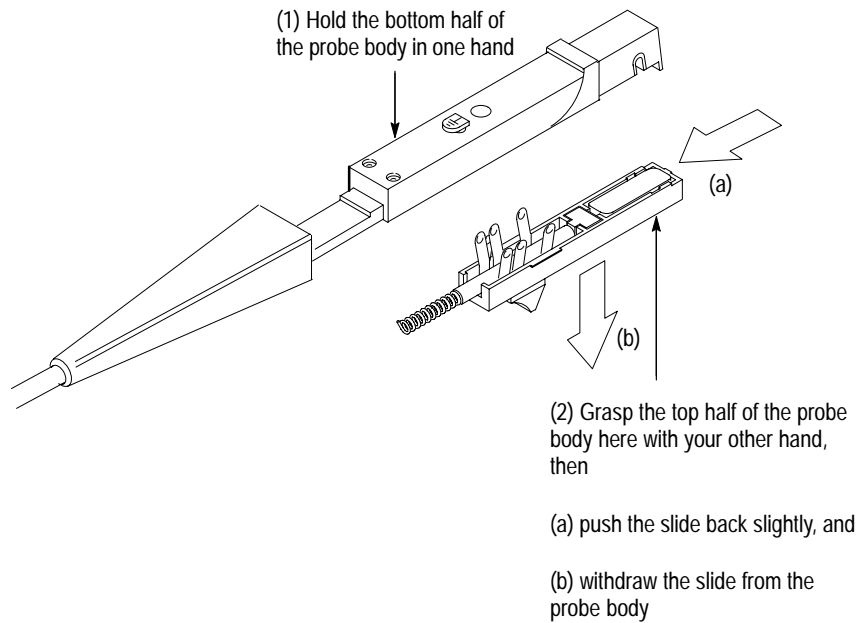

Figure 10: Removing the probe slide

Replacing the Current Transformer or Cable Assembly of the A6302 Probe

Replace the current transformer or cable assembly of the A6302 probe as follows:

1. To remove the current transformer, lift the front edge of the circuit board and transformer out of the probe and then pull the transformer socket off the circuit board pins.
2. To remove the cable assembly, unsolder the two connections on the circuit board then lift the strain relief and circuit board from the body half. Refer to Figure 11.

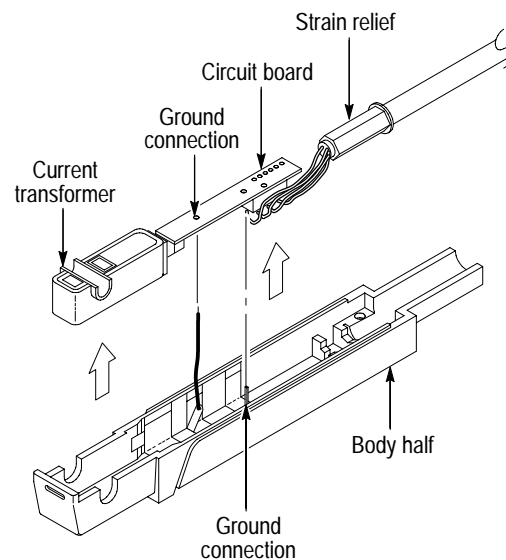

Figure 11: Removing the current transformer and cable assembly of the A6302 probe

3. Before reassembling the probe, be sure that the gap between the stationary and moveable core pieces is clean. If necessary, use isopropyl alcohol or a similar cleaning agent to clean the pieces. Also, clean the contacts of the slide switch, if necessary. Should the plastic slide assembly require lubrication, sparingly apply silicone-based grease to the parts.
4. Probe reassembly is the reverse of steps 1 through 2 of this procedure and steps 1 through 5 on pages 12 through 14.



CAUTION. To avoid damaging the wires inside the probe, carefully dress the wires in the lower body half to avoid contact with the slide assembly. Exercise care when fitting the slide back into the probe body; aligning the switch contacts can require patience.

Replacing the Current Transformer or Cable Assembly of the A6302XL Probe

Replace the current transformer or cable assembly the A6302XL probe as follows:

1. To replace the current transformer, lift the transformer out of the probe as shown in Figure 12, and pull it out of the circuit board socket.
2. To remove the circuit board, unsolder the ground connection on the circuit board and lift the strain relief and the circuit board from the body half.

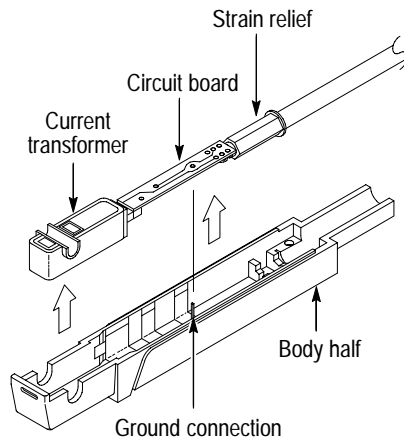

Figure 12: Removing the current transformer of the A6302XL probe

3. Before reassembling the probe, be sure that the gap between the stationary and moveable core pieces is clean. If necessary, use isopropyl alcohol or a similar cleaning agent to clean the pieces. Also, clean the contacts of the slide switch, if necessary. Should the plastic slide assembly require lubrication, sparingly apply silicone-based grease to the parts.
4. Probe reassembly is the reverse of steps 1 through 2 of this procedure and steps 1 through 5 on pages 12 through 14.

NOTE. Exercise care when fitting the slide back into the probe body; aligning the switch contacts can require patience.

Obtaining Replacement Parts

Replacement parts may be obtained through your local Tektronix field office or representative. Refer to the Replaceable Parts List on page 18 for more information.

Preparation for Shipment

If you must ship your Tektronix product, please use the original packaging if possible. If the original packaging is unfit for use or not available, use the following packaging guidelines:

1. Use a corrugated cardboard shipping carton having inside dimensions at least one inch greater than the probe dimensions. The box should have a carton test strength of at least 200 pounds.
2. Put the probe into a plastic bag or wrap to protect it from dampness.
3. Place the probe into the box and stabilize it with light packing material.
4. Seal the carton with shipping tape.

Replaceable Parts

This section contains a list of the replaceable components for the A6302 and A6302XL current probes. Use this list to identify and order replacement parts.

Parts Ordering Information

Replacement parts are available through your local Tektronix field office or representative.

Changes to Tektronix products are sometimes made to accommodate improved components as they become available and to give you the benefit of the latest improvements. Therefore, when ordering parts, it is important to include the following information in your order.

- Part number
- Instrument type or model number
- Instrument serial number
- Instrument modification number, if applicable

If you order a part that has been replaced with a different or improved part, your local Tektronix field office or representative will contact you concerning any change in part number.

Change information, if any, is located at the rear of this manual.

Using the Replaceable Mechanical Parts List

The tabular information in the Replaceable Mechanical Parts List is arranged for quick retrieval. Understanding the structure and features of the list will help you find all of the information you need for ordering replacement parts. The following table describes the content of each column in the parts list.

Parts List Column Descriptions

| Column | Column Name | Description |
|---------|-----------------------|--|
| 1 | Figure & Index Number | Items in this section are referenced by figure and index numbers to the exploded view illustrations. |
| 2 | Tektronix Part Number | Use this part number when ordering replacement parts from Tektronix. |
| 3 and 4 | Serial Number | Column three indicates the serial number at which the part was first effective. Column four indicates the serial number at which the part was discontinued. No entries indicates the part is good for all serial numbers. |
| 5 | Qty | This indicates the quantity of parts used. |
| 6 | Name & Description | An item name is separated from the description by a colon (:). Because of space limitations, an item name may sometimes appear as incomplete. Use the U.S. Federal Catalog handbook H6-1 for further item name identification. |
| 7 | Mfr. Code | This indicates the code of the actual manufacturer of the part. |
| 8 | Mfr. Part Number | This indicates the actual manufacturer's or vendor's part number. |

Abbreviations Abbreviations conform to American National Standard ANSI Y1.1–1972.

Mfr. Code to Manufacturer Cross Index The table titled Manufacturers Cross Index shows codes, names, and addresses of manufacturers or vendors of components listed in the parts list.

Replaceable Parts

A6302 Replaceable parts list

| Fig. & Index Number | Tektronix Part Number | Serial No. Effective | Serial No. Discont'd | Qty | Name & Description | Mfr. Code | Mfr. Part Number |
|---------------------|-----------------------|----------------------|----------------------|-----|---|-----------|------------------|
| 13- | ----- | | | 1 | PROBE, CURRENT:A6302 | | |
| -1 | 204-0288-03 | | | 1 | BODY HALF,PROBE:UPPER BODY HALF,BLACK,POLY | 80009 | 204-0288-03 |
| -2 | 214-0835-00 | | | 1 | SPRING,HLCPS:0.127 OD X 2.65 L,SST | 91260 | ORDER BY DESCR |
| -3 | 214-0849-00 | | | 1 | RTNR RETURN SPR:BRS CD PL | 80009 | 214-0849-00 |
| -4 | 352-0106-00 | | | 1 | HOLDER,SPR RTNR:DELRLN | TK2565 | 352-0106-00 |
| -5 | 175-1836-05 | B010100 | B064999 | 1 | CABLE ASSY,RF:W/CIRCUIT BOARD, A6302 | 80009 | 175-1836-05 |
| | 175-1836-06 | B065000 | B071999 | 1 | CABLE,ASSY,RF:W/CIRCUIT BOARD, A6302 | 80009 | 175-1836-06 |
| | 175-1836-07 | B072000 | | 1 | CABLE ASSY:CABLE W/CIRCUIT BOARD,A6302 | 80009 | 175-1836-07 |
| -6 | 213-0087-00 | | | 2 | SCREW,TPG,TC:2-32 X 0.5,TYPE BT,PANHEAD,STEEL,CADIUM PLATED,POZIDRIVE | 3M099 | ORDER BY DESCR |
| -7 | 334-9048-00 | | | 1 | MARKER,IDENT:PROBE IDENT LABEL,A6302, | 80009 | 334-9048-00 |
| -8 | 204-0714-06 | | | 1 | BODY,HALF:LOWER BODY HALF W/CONTACTS | 80009 | 204-0714-06 |
| -9 | 120-0464-02 | B010100 | B064999 | 1 | TRANSFORMER,CUR:UPPER & LOWER | 80009 | 120-0464-02 |
| | 120-0464-04 | B065000 | | 1 | TRANSFORMER,CUR:UPPER & LOWER | 80009 | 120-0464-04 |
| -10 | 214-0854-00 | | | 1 | CONTACT,ELEC:UPPER SHELF,CU BE | TK1947 | 214-0854-00 |
| -11 | 351-0121-01 | | | 1 | CONT ASSY,ELEC:PROBE SLIDE ASSY | 80009 | 351-0121-01 |
| -12 | 214-0997-00 | | | 1 | BALL,BEARING:0.094,SST | 05469 | ORDER BY DESCR |
| | | | | | Standard Accessories | | |
| -13 | 020-0167-01 | | | 1 | ACCESSORY PKG: LEAD,ELECTRICAL,PROBE GROUND:SDI,23 AWG,6.0 L | 80009 | 020-0167-01 |
| | 070-3905-04 | | | 1 | MANUAL,TECH:INSTRUCTIONS,A6302,A6302XL,DP | 80009 | 070-3905-04 |

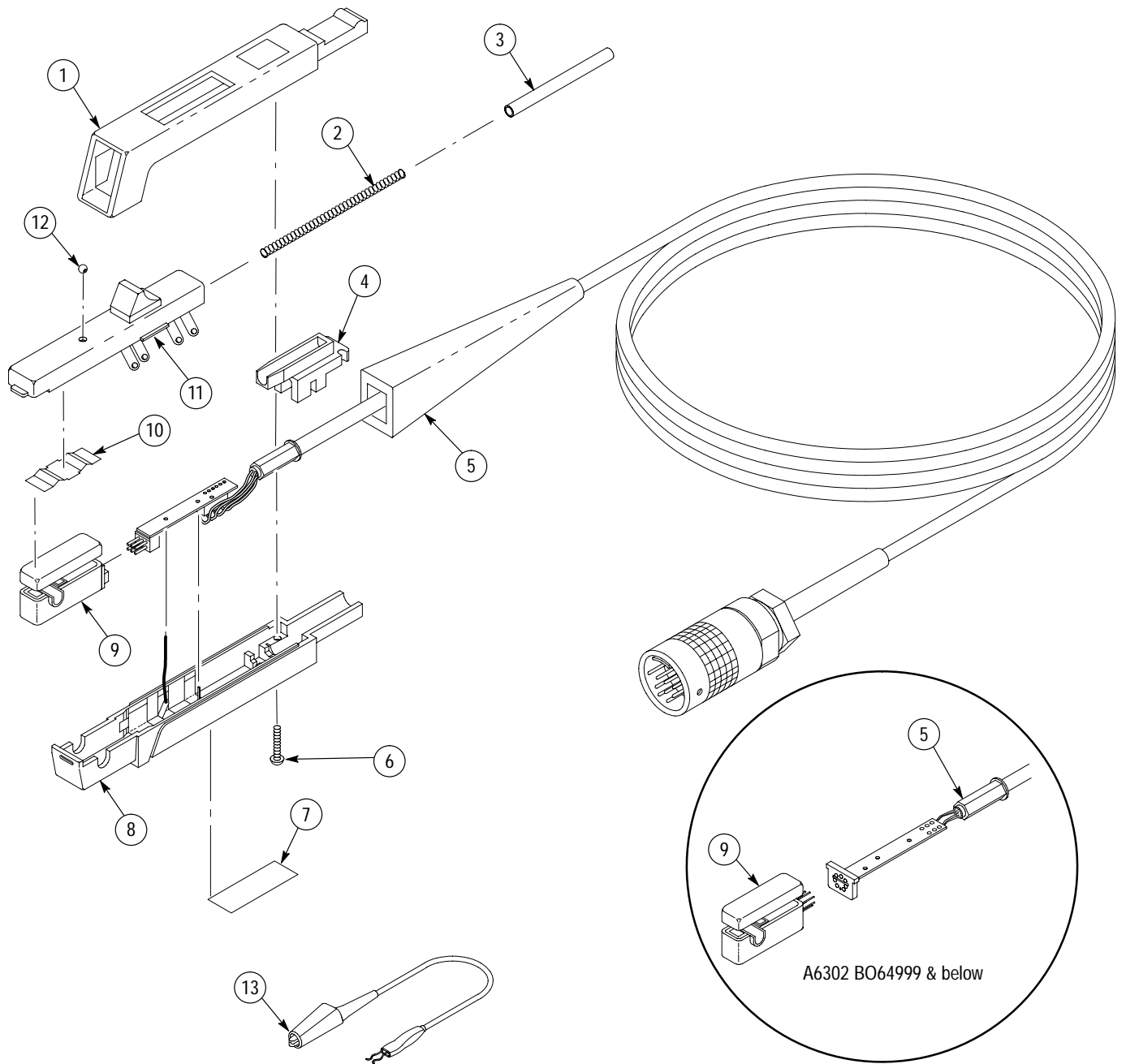

Figure 13: A6302 exploded view

A6302XL Replaceable Parts List

| Fig. & Index Number | Tektronix Part Number | Serial No. Effective | Serial No. Discont'd | Qty | Name & Description | Mfr. Code | Mfr. Part Number |
|---------------------|-----------------------|----------------------|----------------------|-----|--|-----------|------------------|
| 14- | ----- | | | 1 | PROBE,CURRENT:A6302XL | | |
| -1 | 204-0288-03 | | | 1 | BODY HALF,PROBE:UPPER | 80009 | 204-0288-03 |
| -2 | 214-0835-00 | | | 1 | SPRING,HLCPS:0.127 OD X 2.65 L,SST | 91260 | ORDER BY DESC |
| -3 | 214-0849-00 | | | 1 | RTNR RETURN SPR:BRS CD PL | 80009 | 214-0849-00 |
| -4 | 352-0106-00 | | | 1 | HOLDER,SPR RTNR:DELRIN | TK2565 | 352-0106-00 |
| -5 | 174-3221-00 | B010100 | B010999 | 1 | CABLE ASSEMBLY:WITH CIRCUIT BOARD, A6302XL | 80009 | 174-3221-00 |
| | 174-3221-01 | B011000 | | 1 | CABLE ASSEMBLY:WITH CIRCUIT BOARD, A6302XL | 80009 | 174-3221-01 |
| -6 | 213-0087-00 | | | 2 | SCREW,TPG,TC:2-32 X 0.5,TYPE BT,PANHEAD, STEEL,CADIUM PLATED,POZIDRIVE | 3M099 | ORDER BY DESC |
| -7 | 334-9049-00 | | | 1 | LABEL,LEXAN:IDENTIFICATION,A6302XL, | 80009 | 334-9049-00 |
| -8 | 204-0714-03 | B010100 | B010999 | 1 | BODY HALF,PROBE:BOTTOM W/CONTACTS | 80009 | 204-0714-03 |
| | 204-0714-06 | B011000 | | 1 | BODY,HALF:BODY HALF,PROBE, BOTTOM,W/CONTACTS | 80009 | 204-0714-06 |
| -9 | 120-0464-02 | B010100 | B010999 | 1 | TRANSFORMER,CUR:UPPER & LOWER | 80009 | 120-0464-02 |
| | 120-0464-04 | B011000 | | 1 | TRANSFORMER,CUR:UPPER & LOWER | 80009 | 120-0464-04 |
| -10 | 214-0854-00 | | | 1 | CONTACT,ELEC:UPPER SHELF,CU BE | 80009 | 214-0854-00 |
| -11 | 351-0121-01 | | | 1 | CONT ASSY,ELEC:PROBE SLIDE ASSY | TK2565 | 351-0121-01 |
| -12 | 214-0997-00 | | | 1 | BALL,BEARING:0.094,SST | 05469 | ORDER BY DESC |
| | | | | | Standard Accessories | | |
| -13 | 020-0167-01 | | | 1 | ACCESSORY PKG: LEAD,ELECTRICAL,PROBE GROUND;SDI,23 AWG,6,0 L | 80009 | 020-0167-01 |
| | 070-3905-04 | | | 1 | MANUAL,TECH:INSTRUCTIONS,A6302,A6302XL,DP | 80009 | 070-3905-04 |

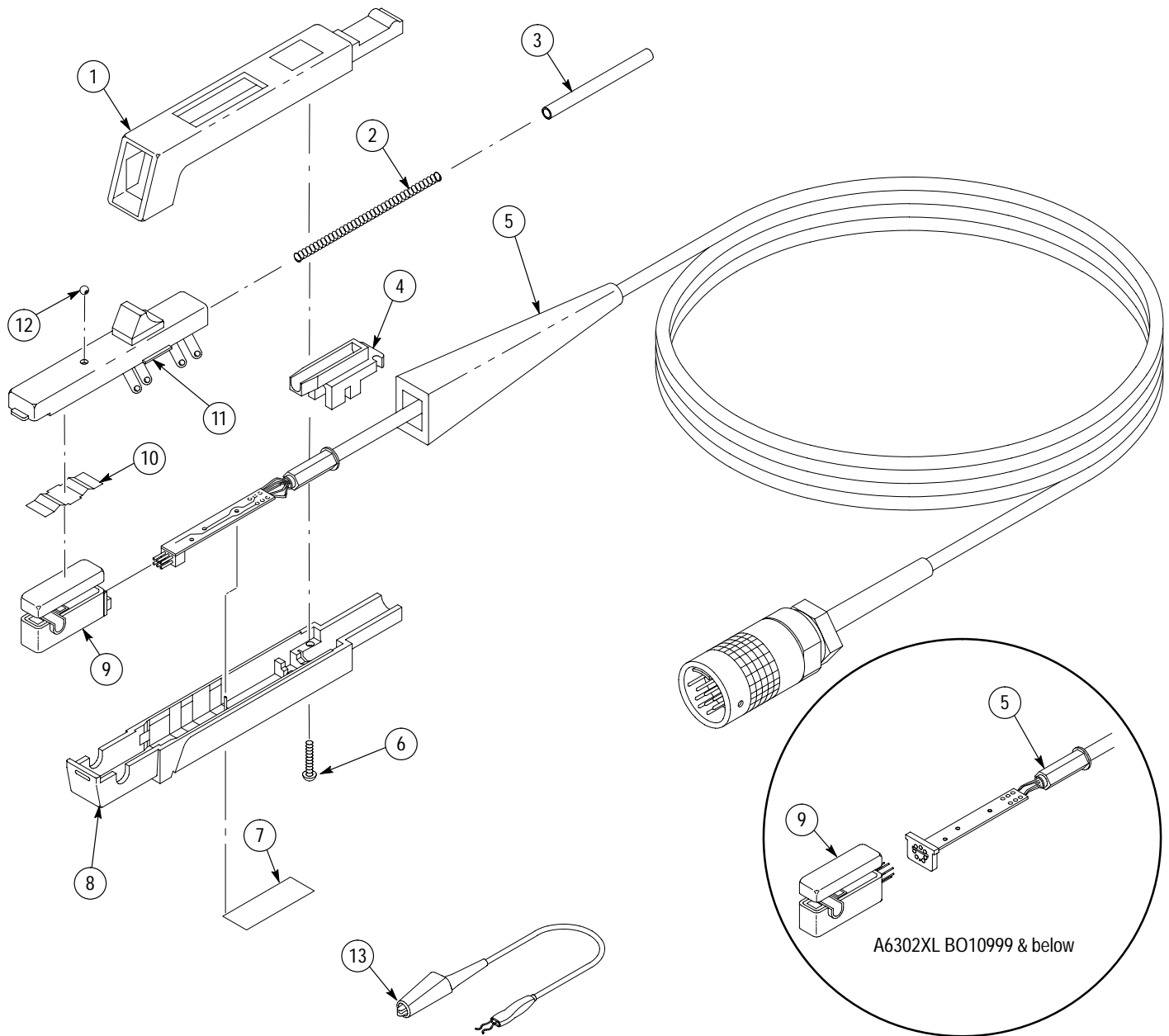

Figure 14: A6302XL exploded view

Manufacturers cross index

| Mfr. Code | Manufacturer | Address | City, State, Zip Code |
|----------------------|------------------------------|--------------------------------------|------------------------------|
| 05469 | BEARINGS INC | 3634 EUCLID PO BOX 6925 | CLEVELAND, OH 44101 |
| 3M099 | PORTLAND SCREW COMPANY | 6520 N BASIN AVE | PORTLAND, OR 97217 |
| 80009 | TEKTRONIX INC | 14150 SW KARL BRAUN DR PO BOX 500 | BEAVERTON, OR 97077-0001 |
| 91260 | CONNOR FORMED METAL PRODUCTS | 1729 JUNCTION AVENUE | SAN JOSE, CA 95112 |
| TK1947 | NORTHWEST ETCH TECHNOLOGY | 2601 S HOOD ST PO BOX 110610 | TACOMA, WA 98411-0610 |
| TK2565 | VISION PLASTICS INC | 26000 SW PARKWAY CENTER DRIVE | WILSONVILLE, OR 97070 |