

Service Manual



AWG7000 Series Arbitrary Waveform Generators

071-1854-01

Warning

The servicing instructions are for use by qualified personnel only. To avoid personal injury, do not perform any servicing unless you are qualified to do so. Refer to all safety summaries prior to performing service.

www.tektronix.com

Copyright © Tektronix. All rights reserved. Licensed software products are owned by Tektronix or its suppliers and are protected by United States copyright laws and international treaty provisions.

Tektronix products are covered by U.S. and foreign patents, issued and pending. Information in this publication supercedes that in all previously published material. Specifications and price change privileges reserved.

TEKTRONIX and TEK are registered trademarks of Tektronix, Inc.

Contacting Tektronix

Tektronix, Inc.
14200 SW Karl Braun Drive or P.O. Box 500
Beaverton, OR 97077
USA

For product information, sales, service, and technical support:

- In North America, call 1-800-833-9200.
- Worldwide, visit www.tektronix.com to find contacts in your area.

Warranty 2

Tektronix warrants that this product will be free from defects in materials and workmanship for a period of one (1) year from the date of shipment. If any such product proves defective during this warranty period, Tektronix, at its option, either will repair the defective product without charge for parts and labor, or will provide a replacement in exchange for the defective product. Parts, modules and replacement products used by Tektronix for warranty work may be new or reconditioned to like new performance. All replaced parts, modules and products become the property of Tektronix.

In order to obtain service under this warranty, Customer must notify Tektronix of the defect before the expiration of the warranty period and make suitable arrangements for the performance of service. Customer shall be responsible for packaging and shipping the defective product to the service center designated by Tektronix, with shipping charges prepaid. Tektronix shall pay for the return of the product to Customer if the shipment is to a location within the country in which the Tektronix service center is located. Customer shall be responsible for paying all shipping charges, duties, taxes, and any other charges for products returned to any other locations.

This warranty shall not apply to any defect, failure or damage caused by improper use or improper or inadequate maintenance and care. Tektronix shall not be obligated to furnish service under this warranty a) to repair damage resulting from attempts by personnel other than Tektronix representatives to install, repair or service the product; b) to repair damage resulting from improper use or connection to incompatible equipment; c) to repair any damage or malfunction caused by the use of non-Tektronix supplies; or d) to service a product that has been modified or integrated with other products when the effect of such modification or integration increases the time or difficulty of servicing the product.

THIS WARRANTY IS GIVEN BY TEKTRONIX WITH RESPECT TO THE PRODUCT IN LIEU OF ANY OTHER WARRANTIES, EXPRESS OR IMPLIED. TEKTRONIX AND ITS VENDORS DISCLAIM ANY IMPLIED WARRANTIES OF MERCHANTABILITY OR FITNESS FOR A PARTICULAR PURPOSE. TEKTRONIX' RESPONSIBILITY TO REPAIR OR REPLACE DEFECTIVE PRODUCTS IS THE SOLE AND EXCLUSIVE REMEDY PROVIDED TO THE CUSTOMER FOR BREACH OF THIS WARRANTY. TEKTRONIX AND ITS VENDORS WILL NOT BE LIABLE FOR ANY INDIRECT, SPECIAL, INCIDENTAL, OR CONSEQUENTIAL DAMAGES IRRESPECTIVE OF WHETHER TEKTRONIX OR THE VENDOR HAS ADVANCE NOTICE OF THE POSSIBILITY OF SUCH DAMAGES.

Table of Contents

General Safety Summary	vii
Service Safety Summary	ix
Environmental Considerations	xi
Preface	xiii
Manual Structure	xiii
Manual Conventions	xiii

Operating Information

General Features	1-1
------------------------	-----

Theory of Operation

Overview	2-1
Module Overviews	2-3

Adjustment Procedures

Adjustment Interval	3-1
Adjustment After Repair	3-1
Required Equipment	3-2
Adjustment Overview	3-2
Calibration Procedure	3-5

Maintenance

Preparation	4-1
Preventing ESD	4-1
Inspection and Cleaning	4-2
Removal and Installation Procedures	4-7
Preparation	4-7
Summary of Procedures	4-8
Required Equipment	4-10
Disconnecting and Connecting the SMP cable	4-10
Procedures for External Modules	4-11
Procedures for Internal Modules (Upper)	4-18
Procedures for Internal Modules (Lower)	4-27
Checking Proper Connection of SMP Connectors	4-37
Troubleshooting	4-39
Equipment Required	4-39
Fault Isolation Procedure	4-39
Instrument Diagnostics	4-44
Calibration Error	4-49
Hardware Error	4-53
After Repair	4-55
Returning the Instrument for Service	4-56

Replaceable Parts

Parts Ordering Information	5-1
Using the Replaceable Parts List	5-3

List of Figures

Figure 2-1: AWG7000 Series block diagram	2-2
Figure 3-1: Service UI menu	3-3
Figure 3-2: 10 MHz Reference calibration initial test hookup	3-5
Figure 3-3: 10 MHz Reference Calibration setup window	3-6
Figure 3-4: Data timing calibration initial hookup	3-7
Figure 3-5: Data Timing Calibration setup window	3-8
Figure 3-6: Inter-channel skew calibration initial hookup	3-12
Figure 3-7: Inter-Channel Skew Calibration setup window	3-13
Figure 3-8: Interleave calibration initial hookup	3-16
Figure 3-9: Interleave Calibration setup window	3-17
Figure 4-1: Disassembly procedures for external modules and internal modules (top)	4-8
Figure 4-2: Disassembly procedures for internal modules (bottom)	4-9
Figure 4-3: Disconnecting and connecting the SMP cable	4-10
Figure 4-4: Handle, snaps, cosmetic covers, and front-trim unit removal	4-12
Figure 4-5: EMI covers removal	4-14
Figure 4-6: Fan tray unit removal	4-16
Figure 4-7: Disassembly of front-panel assembly	4-17
Figure 4-8: Drive module removal	4-19
Figure 4-9: Multi-Input/Output board removal	4-21
Figure 4-10: Processor module removal	4-23
Figure 4-11: Power Supply and RFI filter removal	4-25
Figure 4-12: Power board removal	4-26
Figure 4-13: Front Connector board, CLK10G module, relay unit, AWG10G board removal	4-28
Figure 4-14: Disassembly of the CLK10G module	4-30
Figure 4-15: Relay unit cable connection for option 02	4-31
Figure 4-16: Relay unit cable connection for option 06	4-32
Figure 4-17: OUT10G board showing the test points	4-38
Figure 4-18: Primary troubleshooting tree (1)	4-40
Figure 4-19: Primary troubleshooting tree (2)	4-41
Figure 4-20: PWR board test points	4-42

Figure 4-21: AWG10G board test points	4-43
Figure 4-22: Diagnostics dialog box	4-44
Figure 4-23: Calibration dialog box	4-49
Figure 5-1: Exploded diagram - Cosmetics	5-5
Figure 5-2: Exploded diagram - EMI Covers	5-6
Figure 5-3: Exploded diagram - Chassies assembly	5-7
Figure 5-4: Exploded diagram - Front-panel assembly	5-9
Figure 5-5: Exploded diagram - Drive module	5-11
Figure 5-6: Exploded diagram - Processor module	5-13
Figure 5-7: Exploded diagram - Power supply assembly	5-15
Figure 5-8: Exploded diagram - PCI/power interface module	5-17
Figure 5-9: Exploded diagram - Fan tray assembly	5-18
Figure 5-10: Exploded diagram - USB module	5-19
Figure 5-11: Exploded diagram - AWG10G/CLK10G/OUT10G modules	5-21
Figure 5-12: Exploded diagram - CLK10G module	5-23
Figure 5-13: Exploded diagram - AWG10G module	5-25
Figure 5-14: Exploded diagram - SMA bracket	5-27
Figure 5-15: Exploded diagram - Relay unit	5-29
Figure 5-16: Exploded diagram - Rear connectors	5-30

List of Tables

Table 1-1: General features	1-1
Table 1-2: Combination of instrument options	1-2
Table 3-1: Test equipment	3-2
Table 4-1: External inspection checklist	4-3
Table 4-2: Internal inspection checklist	4-5
Table 4-3: Tools required for module removal and reinstall	4-10
Table 4-4: Power supply voltages	4-42
Table 4-5: PWR board voltages	4-43
Table 4-6: Diagnostics error	4-45
Table 4-7: Calibration error	4-50
Table 4-8: Hardware error	4-53

General Safety Summary

Review the following safety precautions to avoid injury and prevent damage to this product or any products connected to it.

To avoid potential hazards, use this product only as specified.

Only qualified personnel should perform service procedures.

To Avoid Fire or Personal Injury

Use Proper Power Cord. Use only the power cord specified for this product and certified for the country of use.

Connect and Disconnect Properly. Do not connect or disconnect probes or test leads while they are connected to a voltage source.

Ground the Product. This product is grounded through the grounding conductor of the power cord. To avoid electric shock, the grounding conductor must be connected to earth ground. Before making connections to the input or output terminals of the product, ensure that the product is properly grounded.

Observe All Terminal Ratings. To avoid fire or shock hazard, observe all ratings and markings on the product. Consult the product manual for further ratings information before making connections to the product.

The inputs are not rated for connection to mains or Category II, III, or IV circuits.

Do not apply a potential to any terminal, including the common terminal, that exceeds the maximum rating of that terminal.

Power Disconnect. The power cord disconnects the product from the power source. Do not block the power cord; it must remain accessible to the user at all times.

Do Not Operate Without Covers. Do not operate this product with covers or panels removed.

Do Not Operate With Suspected Failures. If you suspect there is damage to this product, have it inspected by qualified service personnel.

Avoid Exposed Circuitry. Do not touch exposed connections and components when power is present.

Do Not Operate in Wet/Damp Conditions.

Do Not Operate in an Explosive Atmosphere.

Keep Product Surfaces Clean and Dry.

Provide Proper Ventilation. Refer to the manual's installation instructions for details on installing the product so it has proper ventilation.

Symbols and Terms **Terms in this Manual.** These terms may appear in this manual:



WARNING. *Warning statements identify conditions or practices that could result in injury or loss of life.*



CAUTION. *Cautions statements identify conditions or practices that could result in damage to this or other property.*

Terms on the Product. These terms may appear on the product:

DANGER indicates an injury hazard immediately accessible as you read the marking.

WARNING indicates an injury hazard not immediately accessible as you read the marking.

CAUTION indicates a hazard to property including the product.

Symbols on the Product. The following symbols may appear on the product:



WARNING
High Voltage



Protective Ground
(Earth) Terminal



CAUTION
Refer to Manual



Double
Insulated

Service Safety Summary

Only qualified personnel should perform service procedures. Read this Service Safety Summary and the General Safety Summary before performing any service procedures.

Do Not Service Alone. Do not perform internal service or adjustments of this product unless another person capable of rendering first aid and resuscitation is present.

Disconnect Power. To avoid electric shock, switch off the instrument power, then disconnect the power cord from the mains power.

Use Care When Servicing With Power On. Dangerous voltages or currents may exist in this product. Disconnect power, remove battery (if applicable), and disconnect test leads before removing protective panels, soldering, or replacing components.

To avoid electric shock, do not touch exposed connections.

Environmental Considerations

This section provides information about the environmental impact of the product.

Product End-of-Life Handling

Observe the following guidelines when recycling an instrument or component:

Equipment Recycling. Production of this equipment required the extraction and use of natural resources. The equipment may contain substances that could be harmful to the environment or human health if improperly handled at the product's end of life. In order to avoid release of such substances into the environment and to reduce the use of natural resources, we encourage you to recycle this product in an appropriate system that will ensure that most of the materials are reused or recycled appropriately.



The symbol shown to the left indicates that this product complies with the European Union's requirements according to Directive 2002/96/EC on waste electrical and electronic equipment (WEEE). For information about recycling options, check the Support/Service section of the Tektronix Web site (www.tektronix.com).

Mercury Notification. This product uses an LCD backlight lamp that contains mercury. Disposal may be regulated due to environmental considerations. Please contact your local authorities or, within the United States, the Electronics Industries Alliance (www.eiae.org) for disposal or recycling information.

Restriction of Hazardous Substances

This product has been classified as Monitoring and Control equipment, and is outside the scope of the 2002/95/EC RoHS Directive. This product is known to contain lead, cadmium, mercury, and hexavalent chromium.

Preface

This manual contains service information for your instrument. Read this preface to learn how this manual is structured, the conventions it uses, and where to find additional supplemental information related to servicing this product.

You should also read the General and Service safety summaries before servicing the product.

Manual Structure

This manual is divided into chapters, which are made up of related subordinate topics. These topics can be cross referenced as sections.

Be sure to read the introductions to all procedures. These introductions provide important information needed to do the service correctly, safely, and efficiently.

Manual Conventions

This manual uses certain conventions that you should become familiar with before attempting service.

Modules Throughout this manual, any replaceable component, assembly, or part is referred to by the term *module*. A module is composed of electrical and mechanical assemblies, circuit boards, interconnecting cables, and user-accessible controls.

Replaceable Parts This manual refers to any field-replaceable assembly or mechanical part specifically by its name or generically as a replaceable part. In general, a replaceable part is any circuit board or assembly, such as the hard disk drive, or a mechanical part, such as the I/O port connectors, that is listed in the replaceable parts list of this manual.

Safety Symbols and terms related to safety appear in the *Service Safety Summary* found at the beginning of this manual.



Operating Information

Operating Information

For information on installing, operating, and networking the instrument, refer to the *AWG7000 Series Arbitrary Waveform Generators Quick Start User Manual*. This manual is available on the Document CD that came with your instrument, and on the Tektronix Web site (www.tektronix.com/manuals).

General Features

The following table and bulleted list describe the general features of the AWG7000 Series Arbitrary Waveform Generators.

Table 1-1: General features

Feature	AWG7101	AWG7102	AWG7051	AWG7052
Maximum Sample Rate	10 GS/s	10 GS/s (20 GS/s by interleave)	5 GS/s	
D/A Resolution	8 bits or 10 bits (selectable)			
Memory Length	32,400,000 or 64,800,000 (Option 01)			
Analog Bandwidth	3.5 GHz or 5.8 GHz (Option 02, 06)			
Analog Output	1	2	1	2
Maximum Amplitude	2 V _{p-p}			
Marker Output	2	4 (2/channel)	2	4 (2/channel)

- Windows XP Professional operation system
- Up to 64,800,000 memory length (Option 01)
- Extended analog output bandwidth (Option 02)
- Interleave and extended analog output bandwidth (Option 06), AWG7102 only
- A large 10.4 inch (264.2 mm) high resolution XGA color display
- An intuitive, graphical user interface (UI), with built-in online help
- 80 GB removable hard drive
- CD-RW/DVD
- Supports USB 2.0 interface
- LAN (1000/100/10 Base-T)
- Touch screen user interface

Options The following options are available for the instrument:

- Option 01: Memory expansion to 64 MB
- Option 02: Extended analog output bandwidth
- Option 06: Interleave and extended analog output bandwidth

Table 1-2 indicates the available combinations of instrument options.

Table 1-2: Combination of instrument options

	Option 01	Option 02	Option 01, 02	Option 06	Option 01, 06
AWG7102	X			X	X
AWG7101	X	X	X		
AWG7052	X	X	X		
AWG7051	X	X	X		

- Option C3: Calibration service 3 years
- Option C5: Calibration service 5 years
- Option D1: Calibration data report
- Option D3, with Option C3: Calibration data report 3 years
- Option D5, with Option C5: Calibration data report 5 years
- Option R3: Repair service 3 years (including warranty)
- Option R5: Repair service 5 years (including warranty)
- AWG7UP Option M12: AWG7102 Field upgrade for waveform length expansion from 32M to 64M points
- AWG7UP Option M11: AWG7101 Field upgrade for waveform length expansion from 32M to 64M points
- AWG7UP Option M02: AWG7052 Field upgrade for waveform length expansion from 32M to 64M points
- AWG7UP Option M01: AWG7051 Field upgrade for waveform length expansion from 32M to 64M points



Theory of Operation

Theory of Operation

This section describes the electrical operation of the AWG7000 Series Arbitrary Waveform Generators.

Overview

The AWG7000 Series Arbitrary Waveform Generators provide four models with different frequency and numbers of channels. Each model consists of two major sections: the platform section and generator section. The platform section is common to each model.

Block Diagram of the System

The AWG7000 Series Arbitrary Waveform Generators are based on the Tektronix DPO7000 series platform which consists of the μ ATX CPU board and modern components for a PC. The instrument operates with the microsoft Window XP operating system. Figure 2-1 on page 2-2 shows the system level block diagram of the AWG7000 Series.

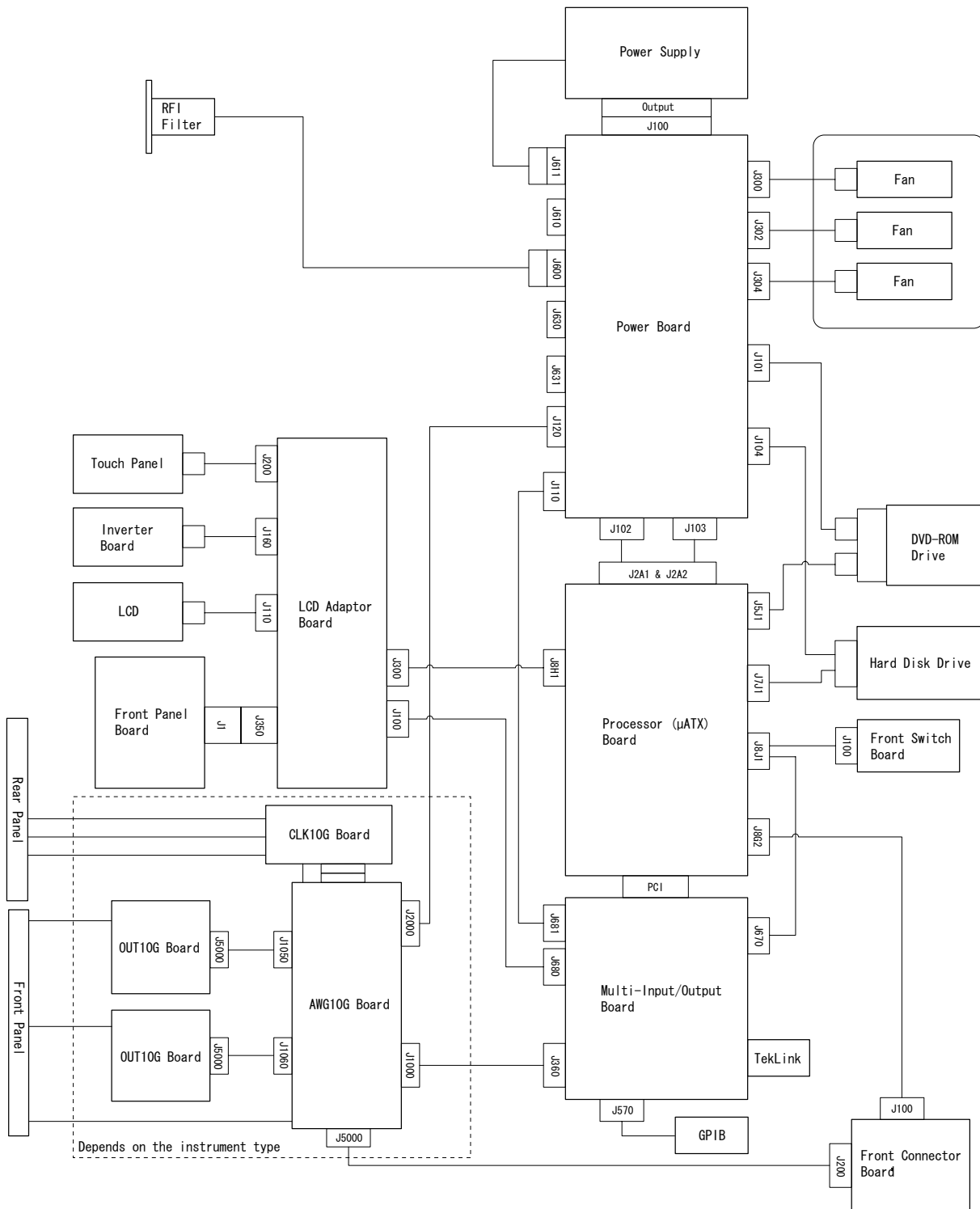

Figure 2-1: AWG7000 Series block diagram

Module Overviews

A Microsoft Windows processor system is the primary controller of the instrument. The instrument features an XGA resolution flat-panel display, a transparent touch screen, and a front panel with direct access to commonly used instrument functions. You can also make complete use of the instrument with a mouse and a keyboard.

Front Panel (FP) Board

Push-button switches on the Front Panel (FP) board are read by an embedded micro controller, which sends the button and knob change information to the μ ATX board via a USB path. The FP board consists of the following blocks:

- USB controller (Cypress EZ-USB FX1)
- FPGA (Altera Cyclone)
- Key switch matrix
- LED indicators (Tri-Color and Mono-Color)

LCD Adapter (LCDA) Board

The LCDA board supports interconnection between the μ ATX board and FP board. Two internal USB ports come from the μ ATX board. One USB connects to a touch panel controller. The other connect to a micro controller on the FP board. Connectors related to the LCD are also included. The LCDA board consists of the following blocks:

- Touch-panel controller
- Rotary encoder (signal goes to the FP board)
- LCD back light controller
- Connector to LCD

Multi-Input/Output (MIO) Board

The MIO board coordinates the flow of data through the Windows PCI port from various devices that communicate with the μ ATX system. The devices include the display system, GPIB, TekLink, and data flow (PCIF) path to the waveform generator system. An EEROM on this board is used to store the instrument setting and calibration data. The MIO board consists of the following blocks:

- PCI controller
- GPIB controller
- LCD display controller (ATI Mobility-MI)
- PCI target adapter
- PLD140 (Xilinx FPGA)
- EEPROM for calibration data storage
- TekLink interface

Front Switch (FSW) Board	The FSW board provides interconnection between the Standby switch and μ ATX board. It includes an LED driver.
Front Connector (FCON) Board	The FCON board provides front-panel connections of the USB ports and the DC output. It includes common mode filters that suppress EMI radiation on the USB signal.
Display Panel	The active-matrix LCD display is fully controlled by Windows drivers. It is controlled by the ATI Mobility-M1 micro circuit on the MIO board. The display has a 1024 x 768 resolution. Brightness is controlled by the intensity of the backlight.
Touch Panel	The touch information from the touch screen is processed by Windows drivers, actively placing the pointer at the touched location. Actions from the mouse and the touch panel are interchangeable, and treated alike by the user interface software. The AccuTouch five-wire resistive touch screen uses a glass panel with a uniform resistive coating. A thick polyester coversheet is tightly suspended over the top of a glass substrate, separated by small, transparent insulating dots. The coversheet has a hard, durable coating on the outer side and a conductive coating on the inner side. The controller is located on the LCDA board.
Processor (μATX) Board	The μ ATX board provides standard Windows functionality and I/O port interfaces on the rear panel. This includes RS-232, Parallel, and Ethernet ports, as well as four USB ports, including two USB2.0 ports located in the lower right front corner of the instrument. The μ ATX board receives input from the front panel and touch panel, and implements the appropriate changes. Video display data is transferred to the MIO board through the PCI bus interface. The hard drive is connected to the μ ATX board through the SATA interface, and the CD/DVD is connected to the Windows system through the IDE parallel interface.
Power Supply	The power supply CVR460 is a switching AC to DC converter. It automatically detects the line voltage over the range of 90 to 264 VAC. It supplies power to all the circuitry in the instrument. No switch completely disconnects the line power from the instrument. The ON/STBY switch controls the power to the instrument through the μ ATX board circuitry. When in the “power off” condition, there is still a low power standby current to allow the system to monitor the ON/STBY switch.
Fans	Three fans on the side of the instrument provide forced air cooling. The fans are controlled by the fan speed control circuit on the PWR board and are regulated by monitoring the temperature at the circuitry.
Power (PWR) Board	The PWR board provides DC power to the fans, HDD, CD Drive, μ ATX board, MIO board, and AWG10G board. All the power comes from the CVR460 module. The fan control circuit has a thermal sensor on this board. DC voltage to the fans is controlled relative to the sensed temperature. DC-DC converters are included for generating different DC voltages.

CLK10G Board

The CLK10G board provides a 5 GHz to 10 GHz clock to the AWG10G board. Two clock outputs go to the CH1 and CH2 DAC. The clock output to CH2 should be terminated for 1 channel models. The clock input accepts 5GHz to 10 GHz clock signals from an external signal source. The reference clock input accepts 5 MHz to 800 MHz reference clock signals from an external signal source. The 10 MHz reference output can be used for synchronizing frequency between two or more instruments. The CLK10G board consists of the following blocks:

- YIG oscillator (5GHz to 10 GHz)
- Fractional-N PLL
- 10.0 MHz TCXO (reference oscillator)

AWG10G Board

The AWG10G board generates arbitrary waveforms based on the waveform memory and the sequence memory. There are two types of PLDs (Xilinx FPGA) on the board. One is an AWG controller called PLD131 which interfaces to/from the MIO board. The other is a memory controller called PLD130 which generates waveform patterns. Waveform data is stored in ZBT type SRAMs. The sequence memory is included in the memory controller PLD. The AWG10G board consists of the following blocks:

- 10 GS/s DAC (HFD205 ASIC)
- 8 channels 8:1 MUX (TEK0015 ASIC)
- PLD130 (Xilinx Virtex-2 FPGA) as a memory controller
- PLD131 (Xilinx Virtex-2 FPGA) as an AWG controller
- ZBT type SRAM for the waveform memory
- Inter-channel phase detector
- Trigger and event inputs
- DC Output
- DC-DC converter (1.5 V and 2.5 V power supply)

OUT10G1 Board for Standard models

The OUT10G1 board provides analog and marker outputs to the front-panel connector. Amplitude, filter, offset, and On/Off controls are added to the analog outputs. High/Low voltage and On/Off controls are added to the marker outputs. The OUT10G1 board consists of the following blocks:

- Analog output amplifier
- Marker output driver
- Selectable low-pass filter
- Selectable attenuator
- Voltage monitor
- Controller PLD

OUT10G2 Board for Option 02/06

The OUT10G2 board uses the same raw board as the OUT10G1 board. The difference is that the OUT10G2 board has no analog output circuitry. For Option 02 and Option 06, the analog signal path is on the relay module. The OUT10G2 board has an analog voltage monitor. The OUT10G2 board consists of the following blocks:

- Marker output driver
- Voltage monitor
- Coax switch driver
- Controller PLD

Relay Module (Option 02 and Option 06 only)

The relay module provides switches for analog outputs. For Option 02, the relays switch the analog outputs on and off. For Option 06, the relays switch the interleaving and the analog outputs on and off. An RF power combiner is used for mixing channel 1 and 2 signals. The output of the power combiner goes to the Interleave output.



Adjustment Procedures

Adjustment Procedures

This section contains information about instrument adjustment. Only qualified personnel should perform adjustment procedures. Read the *Service Safety Summary* and the *General Safety Summary* before performing any service procedures.

NOTE. Before performing adjustment procedures, you must warm up the arbitrary waveform generator at least 20 minutes in an ambient temperature between 20 °C and 30 °C. Adjustments performed before warm-up or outside this temperature range may result in poor performance.

Adjustment Interval

If the instrument fails performance tests (refer to the *AWG7000 Series Arbitrary Waveform Generators Technical Reference Manual*), then adjustment may be required.

If periodic calibration is one of your requirements, a general rule is to verify performance and make adjustments (only if needed) every 2000 hours of operation or once a year if the instrument is used infrequently.

Adjustment After Repair

After removal and replacement of a module, you must perform the Performance Verification procedure, found in the *AWG7000 Series Arbitrary Waveform Generators Technical Reference Manual*. The Technical Reference PDF manual is included in the Product Documentation CD. This manual is also available on the Tektronix Web site (www.tektronix.com/manuals).

Required Equipment

The following equipment, or a suitable equivalent, is required to complete these procedures.

Table 3-1: Test equipment

Description	Minimum requirements	Examples	Quantity
Sampling oscilloscope	Bandwidth: 20 GHz or higher	Tektronix CSA8200 with 80E03	1 ea
Oscilloscope	Bandwidth: 1 GHz or higher	Tektronix TDS5104B	1 ea
Frequency counter	Accuracy: within ± 0.01 ppm	Agilent 53181A	1 ea
50 Ω BNC cable	DC to 2 GHz	Tektronix 012-0482-00	1 ea
50 Ω SMA cable	DC to 20 GHz	Tensolite 1-3636-465-5236	2 ea
50 Ω SMA Termination	DC to 18 GHz	Tektronix 015-1022-01	3 ea
SMA-BNC adapter	SMA male to BNC female	Tektronix 015-0554-00	2 ea
50 Ω SMA Attenuator	DC to 18 GHz, 12 dB	Hirose AT-112	2 ea

Adjustment Overview

The adjustment procedure contains up to ten adjustment items, depending on the instrument type and options. Before performing adjustment procedures, you must warm up the arbitrary waveform generator at least 20 minutes in an ambient temperature between 20 °C and 30 °C.

Enable the Service Menu

You must enable the Service menu to perform the adjustment procedure. To do this:

1. Power on the instrument.
2. Select the **System** menu from the menu bar, and then select **Service Mode...**
3. The following dialog box is displayed. Enter the password “1185”.

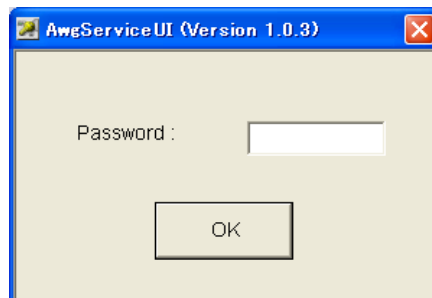

4. The following service UI menu is displayed:

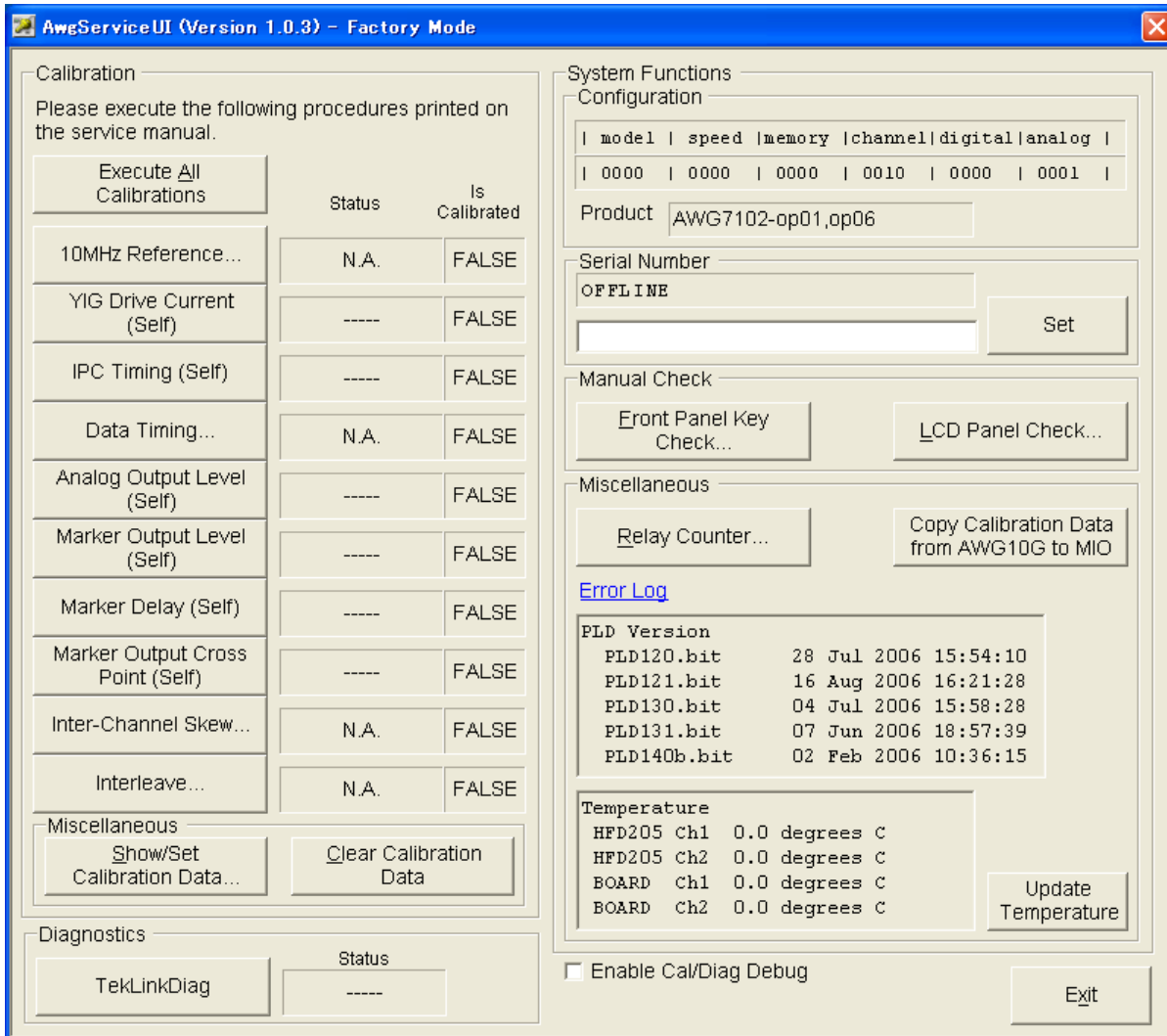

Figure 3-1: Service UI menu

The left half of the window with the title *Calibration* is the calibration part of the window. You can perform the calibrations either all in one step or individually. However, since the calibration sequence is predefined, follow the sequence from the top. You must finish a calibration item listed on the upper part of the screen before performing the lower part of the items. Some items may be grayed out, depending on your instrument option configurations.

Individual Calibrations

To perform individual calibrations, click the calibration buttons, starting with **10MHz Reference...**, and the corresponding calibrations are executed.

Execute All Calibrations

To perform all calibrations in one step, click **Execute All Calibrations** and all calibrations are executed in order starting from the top. However, since data timing calibrations are quite time consuming, it is acceptable to perform only Step 4 (Magic Cal. -2), which depends on the instrument power supply, and skip the other steps. Instead of performing all the steps in the data timing calibration, restore and use the calibration constants obtained by the ATS (Auto Test System) at the factory or during servicing. The following procedures assume that this method will be used.

Saving the Calibration Results to EEPROM

When the calibration has been performed and the results are saved to the EEPROM (regardless of the item, all results are saved to the EEPROM on the MIO board), the flag under *Is Calibrated* will be set to TRUE. If the calibration was successful, the *Status* field will display PASS. If the calibration failed, FAIL will be displayed.

There are two types of calibration: Self calibration and Manual calibration.

- Self calibration – The instrument performs the calibration item and ends automatically.
- Manual calibration – This calibration item requires external devices listed on Table 3-1 and manual data input.

A warning message is displayed if you click a calibration button without waiting for 20 minutes after the instrument powered on. Click the Cancel button and allow at least 20 minutes for the instrument to warm up.

Calibration Procedure

Before starting the calibration procedure, you need to restore the calibration constants that were obtained by ATS (Automatic Test System) at the factory or the service center.

Restoring the Calibration Constants

Click the **Copy Calibration Data from AWG10G to MIO** button in the middle right of the Service UI window.

The calibration data saved to the EEPROM on the AWG10G board during the ATS calibration is restored to the EEPROM on the MIO board. The calibration data on the MIO board EEPROM is used during the following calibration procedure.

10 MHz Reference Calibration

This procedure adjusts the built-in TCXO oscillator frequency for the 10 MHz Reference Output.

Equipment required	One frequency counter
	One 50 Ω BNC cable

1. Install the test hookup and preset the instrument controls:
 - a. Connect a BNC cable from the 10 MHz Reference Output on the rear panel of the arbitrary waveform generator to the CHANNEL 1 of the frequency counter, as shown in Figure 3-2.

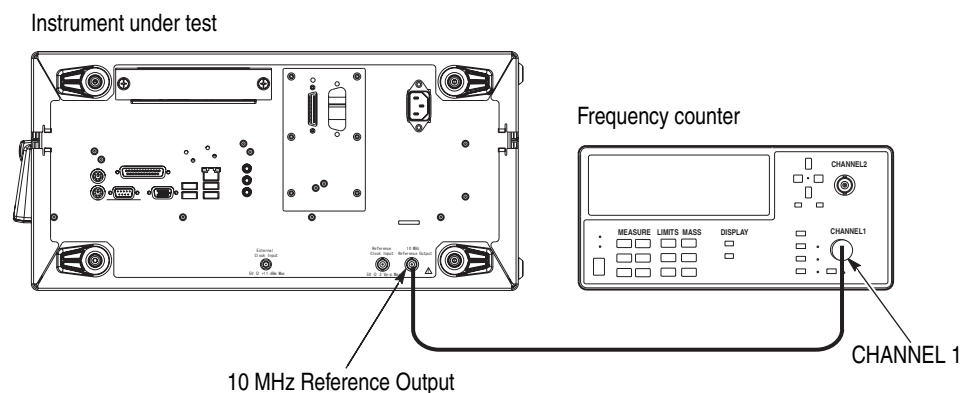

Figure 3-2: 10 MHz Reference calibration initial test hookup

2. Set the frequency counter CHANNEL 1 Impedance to 50 Ω .

- Click the **10 MHz Reference...** button in the Service UI menu to display the following setup window:

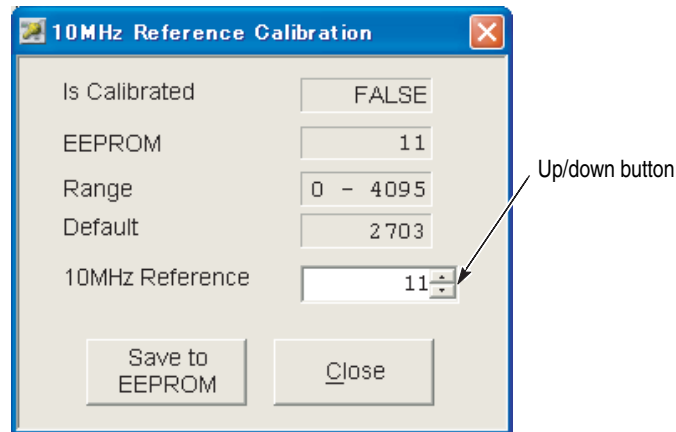

Figure 3-3: 10 MHz Reference Calibration setup window

- Change the *10MHz Reference* value using the up/down button or the front-panel rotary knob so that the frequency counter reading is within the range of 10 MHz \pm 1 Hz.
- Click **Save to EEPROM** to save the data to the EEPROM.
- Click **Close** to close the window.

YIG Drive Current Calibration

This is a self calibration. The YIG for the internal clock source controls the frequency by the main coil (tuning coil) and the FM coil currents. The sensitivity differs between individual YIGs, this calibration is required to set the precise frequency.

IPC Timing Calibration

This is a self calibration. The instrument features high-speed communication called IPC (Inter PLD Communication) between the internal Memory Controller and the Awg Controller. This calibration is required to ensure the optimum timing to enable the IPC in all frequency settings. Failing to perform this calibration may disable access to the waveform memory and/or make the AWG board diagnostics cause an error.

Data Timing Calibration

The instrument operates at extremely high speeds between the waveform memory on the AWG board and the Memory Controller, between the Memory Controller and TEK0015, and between TEK0015 and HFD205.

This calibration is required to ensure the optimum timing to enable waveform outputs in all frequency settings. Failing to perform this calibration may not only disable normal waveform outputs, but may also make the waveform memory diagnostics cause an error.

This calibration consists of six steps from Step 0 to Step 5, but in this manual, perform only Step 4 (Magic Cal.-2). Other calibration constants are restored by using the data acquired by ATS at the factory or during servicing.

Basic steps are to observe output waveforms on the oscilloscope screen, and to determine the range of abnormal outputs, which appears on the oscilloscope as a broken waveform, by adjusting the delay in the TEK0015 Data Output.

Equipment required	One oscilloscope Two SMA-BNC adapters Two 50 Ω SMA cables Two 50 Ω SMA terminations
---------------------------	--

1. Install the test hookup and preset the instrument controls:
 - a. Hook up the oscilloscope:
 - Attach the SMA terminations to the Channel 1 Analog (-) and Channel 2 Analog (-) Outputs on the front panel of the arbitrary waveform generator.
 - Attach the SMA-BNC adapters to the CH 1 and CH 2 Input connectors of the oscilloscope.
 - Connect the SMA cables from the Channel 1 Analog (+) and Channel 2 Analog (+) Outputs on the front panel of the arbitrary waveform generator to the CH 1 and CH 2 Inputs of the oscilloscope, as shown in Figure 3-4.

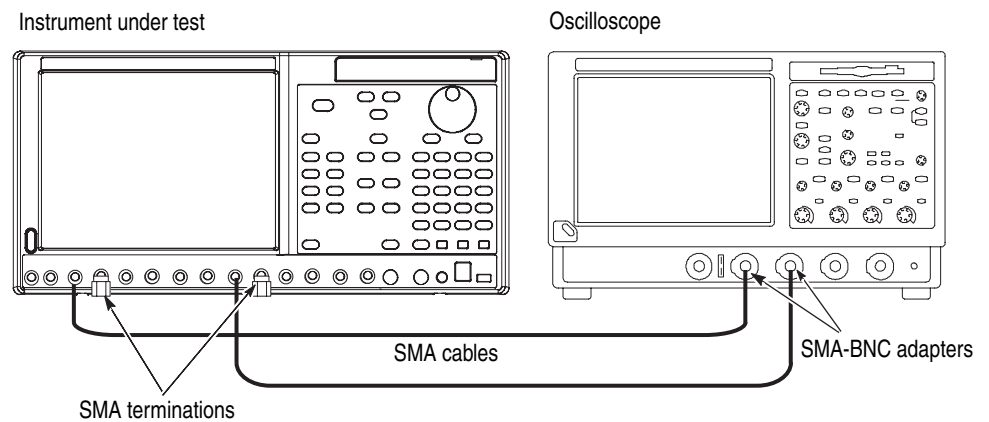

Figure 3-4: Data timing calibration initial hookup

- b. Modify the oscilloscope settings as follows:
 - CH 1 and CH 2 Vertical Scale: 200 mV/div
 - CH 1 and CH 2 Impedance: 50 Ω
 - Horizontal Scale: 20 ns/div
 - Trigger: Edge Trigger, CH 1/CH 2 Rising, Set Level to 50%
2. Click the **Data Timing...** button in the Service UI menu to display the following setup window:

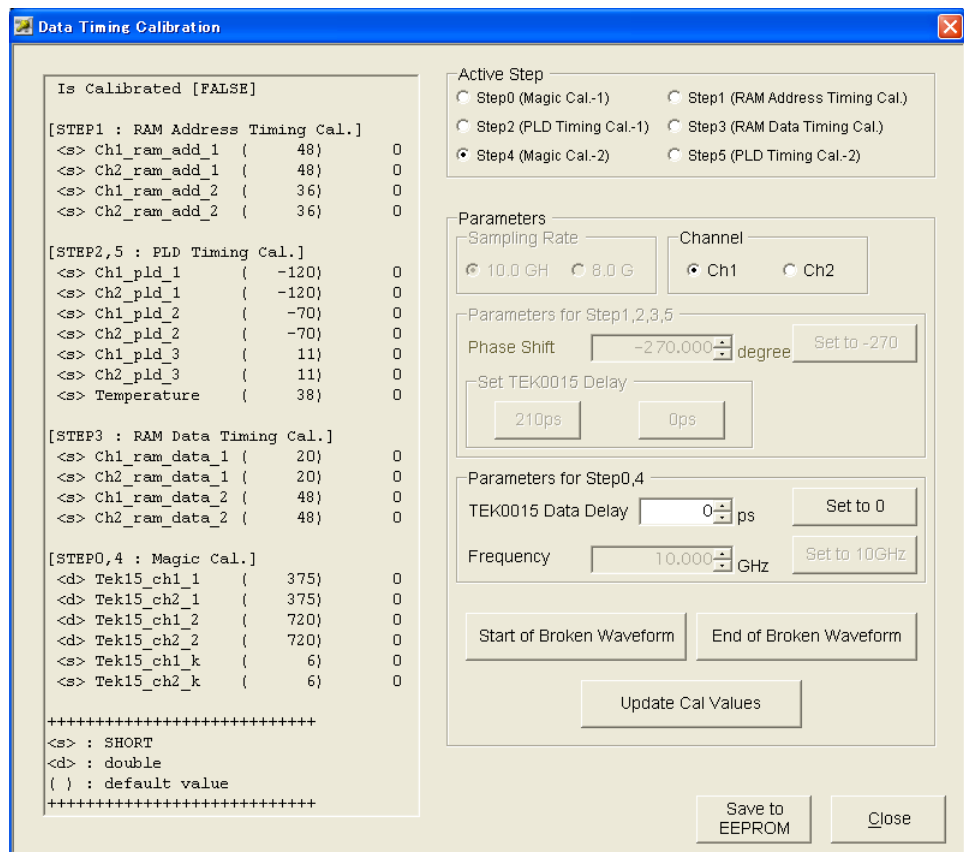
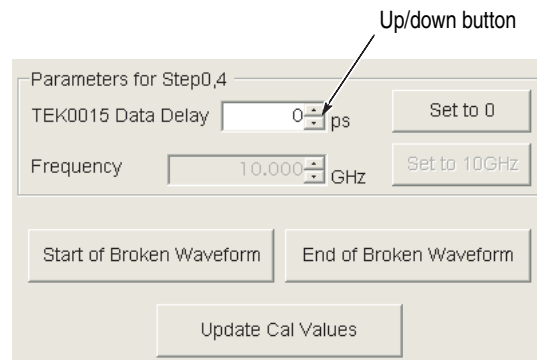

Figure 3-5: Data Timing Calibration setup window

3. Select **Step 4** in the Active Step field.
4. Select **Ch 1** in the Channel field.

- Set **TEK0015 Data Delay** to 0 ns, and observe the oscilloscope screen. If a sine waveform of approximately 102.4 ns period is output normally, increase the **TEK0015 Data Delay** setting by 30 ps using the up/down button or the front-panel rotary knob. You can also enter the value directly using the keyboard.



- Increase the **TEK0015 Data Delay** setting by 30 ps, and observe the oscilloscope screen. If the waveform starts to break at some point, click **Start of Broken Waveform**. The following shows an example of broken waveform:

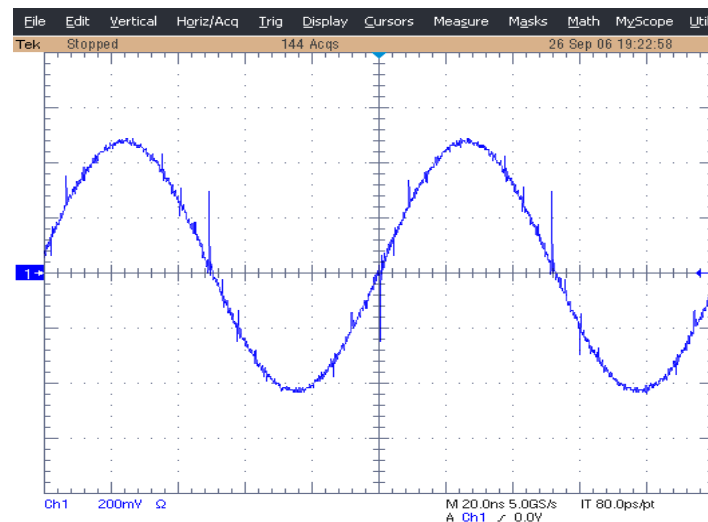

- Click **End of Broken Waveform** right before the next waveform is output normally (the last position where the waveform is broken in that range).
- Continue the measurements up to 990 ps in the **TEK0015 Data Delay** setting.
 - A set value of End of Broken Waveform is always larger than that of Start of Broken Waveform.
 - You can temporarily restore the settings to re-check the waveform.

- Regard the first or last settings where the waveform is broken as the end point of broken waveform. In other words, if you have already click **Start of Broken Waveform**, click **End of Broken Waveform** next.
 - If the waveform is broken with one set value only, and not across a range of multiple settings, click both **Start of Broken Waveform** and **End of Broken Waveform** at the same setting. Always click **Start of Broken Waveform** first.
9. Select **Ch 2** in the Channel field.
 10. Click **Set to 0**. This will reset the value of **TEK0015 Data Delay** to 0 ps.
 11. Repeat step 5 through step 8.
 12. Click **Update Cal Values**.
 13. Select **Ch 1** in the Channel field.
 14. Set **Frequency** to 10 GHz, and observe the oscilloscope screen. If a sine waveform is not output normally, record the range as described in step 6 and step 7.
 15. Decrease **Frequency** in the **Parameters for Step 0,4** field every 50 MHz from 10.000 GHz to 7.000 GHz using the up/down button or the front-panel rotary knob. You can also enter the value directly using the keyboard.
 16. If the waveform starts to break at some point, click **Start of Broken Waveform**. Click **End of Broken Waveform** right before the next waveform is output normally (the last position where the waveform is broken in that range).
 17. Continue the measurement to 7 GHz.
 18. Select **Ch 2** in the Channel field.
 19. Reset the value of **Frequency** to 10 GHz.
 20. Repeat step 14 through step 16.
 21. Click **Update Cal Values**.
 22. Click **Save to EEPROM**.
 23. Click **Close**. The Data Timing Calibration window closes.

Analog Output Level Calibration	This is a self calibration. This calibration is required to ensure that the analog output levels are within the specified range.
Marker Output Level Calibration	This is a self calibration. This calibration is required to ensure that the marker output levels are within the specified range.
Marker Delay Calibration	This is a self calibration. This calibration is required to ensure that the marker delay is within the specified range.
Marker Output Cross Point Calibration	This is a self calibration. This calibration is required to ensure that the marker output cross point is within the specified range.

Inter-Channel Skew Calibration (AWG7102 and AWG7052)

This calibration is required to ensure that the Ch 1 and Ch 2 output skews are set within the specified range. This calibration is applied to both analog and marker outputs.

Equipment required	One sampling oscilloscope Two 50 Ω SMA 12 dB attenuators Two 50 Ω SMA cables Three 50 Ω SMA terminations
---------------------------	--

1. Install the test hookup and preset the instrument controls:

a. Hook up the sampling oscilloscope:

- Attach the SMA terminations to the Channel 1 Analog (–) Output, Channel 2 Analog (–) Output, and Marker 1 (–) Output on the front panel of the arbitrary waveform generator.
- Connect an SMA cable from the Channel 1 Analog (+) Output on the front panel of the arbitrary waveform generator to the CH 1 Input of the sampling oscilloscope using the SMA attenuator, as shown in Figure 3-6.
- Connect an SMA cable from the Channel 1 Marker (+) Output on the front panel of the arbitrary waveform generator to the TRIGGER DIRECT INPUT of the sampling oscilloscope using the SMA attenuator, as shown in Figure 3-6.

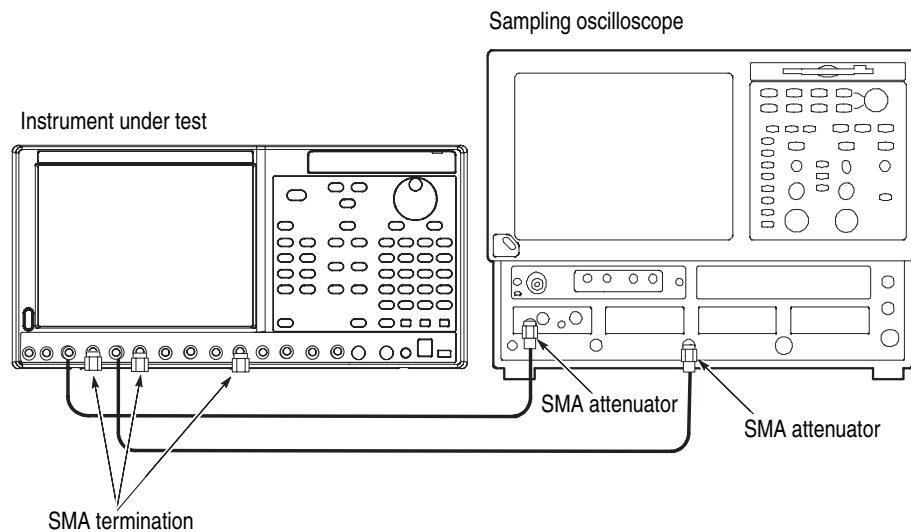

Figure 3-6: Inter-channel skew calibration initial hookup

b. Modify the sampling oscilloscope settings as follows:

- Vertical External Attenuation: 12 dB
- Vertical Scale: 200 mV/div
- Horizontal Scale: 50 ps/div
- Horizontal Timebase Mode: Lock to INT. 10 MHz
- Trigger: External Direct Input, Level 50%
- Acquisition: Average 64, Stop After Condition: Average Complete
- Measurement: R1 to C1 Delay (R1/C1 Reference Level: Absolute 0.0 V)

2. Click the **Inter-Channel Skew...** button in the Service UI menu to display the following setup window:

Is Calibrated FALSE Ch2 Clock Phase degree

Sampling Rate : 5.0 GHz | Sampling Rate : 10.0 GHz

Ch2 Phase (degree)	Delay (ps)	Ch1 - Ch2 Phase (degree)	EEPROM (degree)	Default (degree)	Ch2 Phase (degree)	Delay (ps)	Ch1 - Ch2 Phase (degree)	EEPROM (degree)	Default (degree)
180	0	0	0	226.8	-10	0	0	0	16.2
170	0	0	0	221.4	-20	0	0	0	5.4
160	0	0	0	216.0	-30	0	0	0	-5.4
150	0	0	0	208.8	-40	0	0	0	-16.2
140	0	0	0	199.8	-50	0	0	0	-27.0
130	0	0	0	189.0	-60	0	0	0	-37.8
120	0	0	0	178.2	-70	0	0	0	-48.6
110	0	0	0	167.4	-80	0	0	0	-57.6
100	0	0	0	156.6	-90	0	0	0	-68.4
90	0	0	0	145.8	-100	0	0	0	-75.6
80	0	0	0	138.6	-110	0	0	0	-82.8
70	0	0	0	127.8	-120	0	0	0	-90.0
60	0	0	0	117.0	-130	0	0	0	-97.2
50	0	0	0	106.2	-140	0	0	0	-104.4
40	0	0	0	91.8	-150	0	0	0	-111.6
30	0	0	0	77.4	-160	0	0	0	-120.6
20	0	0	0	63.0	-170	0	0	0	-129.6
10	0	0	0	46.8	-180	0	0	0	-136.8
0	0	0	0	32.4					

Buttons: Calc (Delay to Phase), Save to EEPROM, Close

Figure 3-7: Inter-Channel Skew Calibration setup window

3. Perform the following measurements:
 - a. Adjust the horizontal position of sampling oscilloscope so that the rising edge of the arbitrary waveform generator (AWG7000 series) Ch 1 Analog (+) Output waveform is visible near the center of the oscilloscope screen, and then select File Menu > Save Waveform... to save the waveform data to R1.
 - b. Disconnect the SMA cable from the Ch 1 Analog (+) Output, and then connect it to the Ch 2 Analog (+) Output. Do not use a different cable for the Ch 1 and Ch 2 connectors. Always use the same SMA cable.
 - c. Push **CLEAR DATA** and then **RUN/STOP** on the sampling oscilloscope front panel control.
 - d. Measure **R1 to C1 Delay** using the Measurement function of the sampling oscilloscope with the following settings:
 - Sampling Rate: 5.0 GHz
 - Ch 2 Phase: 0 degree
 - e. If the delay value measured in step **d** is outside ± 100 ps range, change the Sampling Rate setting to 10.0 GHz and then return the setting to 5.0 GHz. Measure **R1 to C1 Delay** again. Repeat this measurement until the **R1 to C1 Delay** value is within the ± 100 ps range.
 - f. Change the sampling oscilloscope settings as follows:
 - Sampling Rate: 5.0 GHz
 - Ch 2 Phase: +180 degree
 - g. Enter the measurement values of **R1 to C1 Delay** for each setting to the first place after the decimal point while changing the Ch 2 Phase settings from +180 degrees to -180 degrees using either the mouse or the Tab key. Adjust the horizontal position of the sampling oscilloscope as necessary so that the rising edge of the waveform is displayed at the center of the screen.
 - h. After you complete all the measurements for **Sampling Rate: 5.0 GHz**, click **Calc (Delay to Phase)**. This will display the calculated phase values in the *Ch1-Ch2 Phase (degree)* field.
 - i. Click **Sampling Rate:10.0 GHz**.
 - j. Disconnect the SMA cable from the Ch 2 Analog (+) Output, and then connect it to the Ch 1 Analog (+) Output.
 - k. Adjust the horizontal position of the sampling oscilloscope so that the rising edge of the arbitrary waveform generator Ch 1 Analog (+) Output waveform is visible near the center of the oscilloscope screen, and then select File Menu > Save Waveform... to save the waveform data to R1.
 - l. Disconnect the SMA cable from the Ch 1 Analog (+) Output, and then connect it to the Ch 2 Analog (+) Output.

- m. Change the sampling oscilloscope settings as follows:
 - Sampling Rate: 10.0 GHz
 - Ch 2 Phase: +180 degree
 - n. Enter the measurement values of **R1 to C1 Delay** for each setting to the first place after the decimal point while changing the Ch 2 Phase settings in the order from +180 degrees to –180 degrees using either the mouse or the Tab key. Adjust the horizontal position of the sampling oscilloscope as necessary so that the rising edge of the waveform is displayed at the center of the screen.
 - o. After you complete all the measurements for **Sampling Rate: 10.0 GHz**, click **Calc (Delay to Phase)**. This will display the calculated phase values in the *Ch1-Ch2 Phase (degree)* field.
4. Click **Save to EEPROM**.
 5. Click **Close**. The Inter-Channel Skew Calibration window closes.

Interleave Calibration (AWG7102 Option 06 only)

This calibration consists of the following two adjustments:

- Coarse adjustment – Adjust the phase difference between Ch 1 and Ch 2 to minimize the rise time of Interleave Output.
- Fine adjustment – Adjust the phase difference between Ch 1 and Ch 2 to minimize the ripples of Interleave Output RZ.

Equipment required	
	One sampling oscilloscope
	One 50 Ω SMA 12 dB attenuator
	Two 50 Ω SMA cables
	Two 50 Ω SMA terminations

1. Install the test hookup and preset the instrument controls:
 - a. Hook up the sampling oscilloscope:
 - Attach the SMA terminations to the Interleave (–) Output and the Marker 1 (–) Output on the front panel of the arbitrary waveform generator.
 - Connect an SMA cable from the Interleave (+) Output on the front panel of the arbitrary waveform generator to the CH 1 Input of the sampling oscilloscope using the SMA attenuator.
 - Connect an SMA cable from the Channel 1 Marker (+) Output on the front panel of the arbitrary waveform generator to the TRIGGER DIRECT INPUT of the sampling oscilloscope using the SMA attenuator, as shown in Figure 3-8.

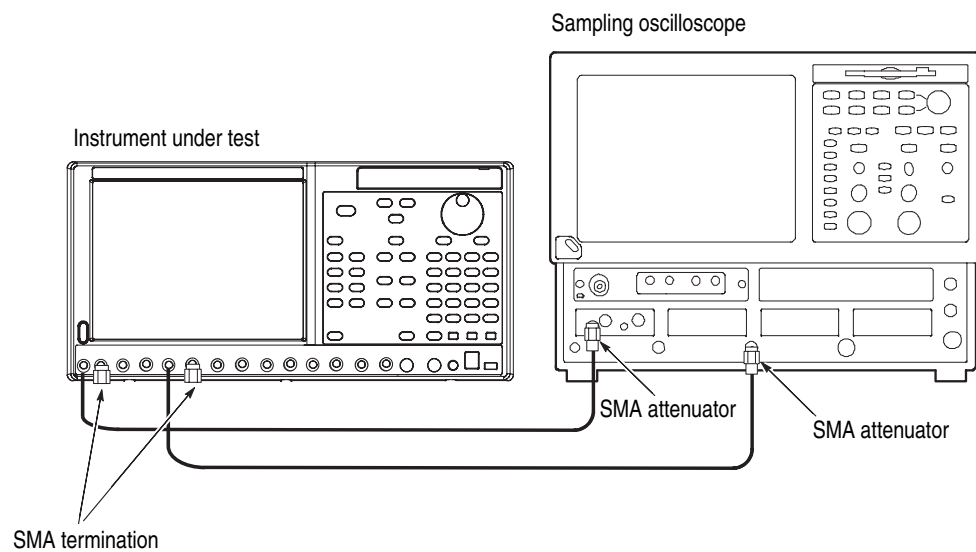

Figure 3-8: Interleave calibration initial hookup

- b. Modify the sampling oscilloscope settings as follows:
- Vertical External Attenuation: 12 dB
 - Vertical Scale: 200 mV/div
 - Horizontal Scale: 50 ps/div
 - Horizontal Timebase Mode: Lock to INT. 10 MHz
 - Trigger: External Direct Input, Level 50%
 - Acquisition: Sample
 - Measurement: C1 Rise Time (C1 Reference Level: Relative 20%-80%)

- Click the **Interleave...** button in the Service UI menu to display the following setup window:

Is Calibrated FALSE

STEP1 : Coarse Adjustment

Init for Coarse Adjustment

Ch2 Clock Phase (= Phase Offset) degree

Set SP (Phase Offset to SP)

SP (Search Point) degree

STEP2 : Fine Adjustment

Init for Fine Adjustment

Sampling Rate

5.0 GHz 7.0 GHz 9.0 GHz

6.0 GHz 8.0 GHz 10.0 GHz

Ch2 HFD205 Phase degree

	Phase (degree)	Skew (ps)	EEPROM (ps)	Default (ps)
Skew5G	<input type="text" value="0"/>	<input type="text" value="0"/>	-19.0	-19.0
Skew6G	<input type="text" value="0"/>	<input type="text" value="0"/>	-16.5	-16.5
Skew7G	<input type="text" value="0"/>	<input type="text" value="0"/>	-13.5	-13.5
Skew8G	<input type="text" value="0"/>	<input type="text" value="0"/>	-15.5	-15.5
Skew9G	<input type="text" value="0"/>	<input type="text" value="0"/>	-18.5	-18.5
Skew10G	<input type="text" value="0"/>	<input type="text" value="0"/>	-18.0	-18.0

Update Cal Values

Save to EEPROM Close

Figure 3-9: Interleave Calibration setup window

- Click **Init for Coarse Adjustment** to set the mode to the Coarse Adjustment settings.
- Identify the minimum rise time point for the Interleave (+) Output using the Measurement function of the sampling oscilloscope while changing the *Ch2 Clock Phase* settings using either the up/down button or the front-panel rotary knob. You can also enter the value directly using the keyboard.
- Click **Set SP (Phase Offset to SP)** at the minimum rise time point to calculate and set the center point (Search Point: SP). The value will be displayed in the SP (Search Point) field.
- Change the vertical and horizontal scale of the sampling oscilloscope to 50 mV/div and 200 ps/div, respectively.
- Click **Init for Fine Adjustment** to set the mode to the Fine Adjustment settings.
- Select **5.0 GHz** in the Sampling Rate field.

9. Identify the minimum amplitude (ripple) point for the Ch1 waveform on the sampling oscilloscope screen while changing the *Ch2 HFD205 Phase* settings using either the up/down button or the front-panel rotary knob. You can also enter the value directly using the keyboard.

The **Skew** for each sampling rate is calculated automatically using the Inter-Channel Skew Cal. results, and the skew values are displayed in the *Skew5G* through *Skew10G* fields.

NOTE. *Ideally, the skew should not depend on the frequency, but there is a slight dependency between skew and frequency.*

10. Stop at the minimum ripple point, and select **6.0 GHz** in the Sampling Rate.
11. Repeat step 9.
12. Stop at the minimum ripple point, and select **7.0 GHz** in the Sampling Rate.
13. Repeat step 9.
14. Stop at the minimum ripple point, and select **8.0 GHz** in the Sampling Rate.
15. Repeat step 9.
16. Stop at the minimum ripple point, and select **9.0 GHz** in the Sampling Rate.
17. Repeat step 9.
18. Stop at the minimum ripple point, and select **10.0 GHz** in the Sampling Rate.
19. Repeat step 9.
20. Stop at the minimum ripple point, and click **Update Cal Values**.
21. Click **Save to EEPROM**.
22. Click **Close**. The Interleave Calibration window closes.
23. Click **Exit** in the Service UI menu.

This completes the adjustment procedures. Disconnect the equipment from the instrument.



Maintenance

Maintenance

This section contains information needed to do periodic and corrective maintenance on the instrument. The following subsections are included:

- *Preparation* — Tells you how to get ready to do arbitrary waveform generator maintenance.
- *Preparation Preventing ESD* — Provides general information on preventing damage to internal modules when doing maintenance.
- *Inspection and Cleaning* — Information and procedures for inspecting the instrument and cleaning its external and internal modules.
- *Removal and Installation Procedures* — Procedures for the removal of defective modules and replacement of new or repaired modules.
- *Troubleshooting* — Information for isolating failed modules. Included are instructions for operating the instrument diagnostic routines and troubleshooting trees. Most of the trees make use of the internal diagnostic routines to speed fault isolation to a module.

Preparation

Only qualified persons should perform service procedures. Before performing any service procedures, read the *Service Safety Summary* and *General Safety Summary* at the front of this manual and the ESD information below. Also refer to the Operating Information section and your arbitrary waveform generator quick start user manual for information about using the arbitrary waveform generator.

Preventing ESD

When performing any service that requires internal access to this instrument, adhere to the following precautions to avoid damaging internal modules and their components due to electrostatic discharge (ESD).



CAUTION. *Static discharge can damage any semiconductor component in this instrument.*

- Minimize handling of static-sensitive modules.
- Transport and store static-sensitive modules in their static protected containers or on a metal rail. Label any package that contains static-sensitive modules.

- Discharge the static voltage from your body by wearing a grounded antistatic wrist strap while handling these modules. Do service of static-sensitive modules only at a static-free work station.
- Do not allow anything capable of generating or holding a static charge on the work station surface.
- Handle circuit boards by the edges when possible.
- Do not slide the modules over any surface.
- Avoid handling modules in areas that have a floor or work-surface covering capable of generating a static charge.

Inspection and Cleaning

Inspection and Cleaning describes how to inspect for dirt and damage, and how to clean the exterior and interior of the instrument. Inspection and cleaning are done as preventive maintenance. Preventive maintenance, when done regularly, may prevent instrument malfunction and enhance its reliability.

Preventive maintenance consists of visually inspecting and cleaning the instrument and using general care when operating it.

How often to do maintenance depends on the severity of the environment in which the instrument is used. A proper time to perform preventive maintenance is just before instrument adjustment.

General Care

For optimum performance, follow these recommendations:

- Protect the instrument from adverse weather conditions. The instrument is not waterproof.
- Do not store or leave the instrument where the liquid crystal display (LCD) will be exposed to direct sunlight or high humidity for long periods of time.
- The cabinet helps keep dust out of the instrument and must be in place during normal operation.
- To avoid damage to the instrument, do not expose it to any sprays, liquids, or solvents.

Inspection and Cleaning procedures

The collection of dirt on internal components can cause them to overheat and fail. Dirt also provides an electrical conduction path that could cause an instrument failure, especially under high-humidity conditions. Inspect the instrument as often as operating conditions require.



WARNING. Before performing any of the following procedures, power down the instrument and disconnect it from line voltage.



CAUTION. Avoid the use of chemical cleaning agents, which might damage the plastics used in this AWG7000 Series Arbitrary Waveform Generator. Use only deionized water when cleaning the front-panel buttons. Use an ethyl alcohol solution as a cleaner and rinse with deionized water.

Inspection — Exterior. Inspect the outside of the instrument for damage, wear, and missing parts, using Table 4-1 as a guide. An instrument that appears to have been dropped or otherwise abused should be checked thoroughly to verify correct operation and performance. Immediately repair defects that could cause personal injury or further damage to the instrument.

Table 4-1: External inspection checklist

Item	Inspect for	Repair action
Cabinet, front-panel, and cover	Cracks, scratches, deformations, damaged hardware or gaskets.	Repair or replace defective module.
Front-panel knob	Missing, damaged, or loose knob.	Repair or replace missing or defective knob.
Connectors	Broken shells, cracked insulation, and deformed contacts. Dirt in connectors.	Repair or replace defective modules. Clear or wash out dirt.
Carrying handle and cabinet feet	Correct operation.	Repair or replace defective module.
Accessories	Missing items or parts of items, bent pins, broken or frayed cables, and damaged connectors.	Repair or replace damaged or missing items, frayed cables, and defective modules.

Cleaning Procedure — Exterior. Do the following steps to clean the instrument exterior:

1. Remove loose dust on the outside of the instrument with a lint-free cloth. Use care to avoid scratching the clear glass display shield.

2. Remove remaining dirt with a lint-free cloth dampened in a general purpose detergent-and-water solution. Do not use abrasive cleaners.



CAUTION. *To prevent getting moisture inside the instrument during external cleaning, use only enough liquid to dampen the cloth or applicator.*

To avoid damage to the surface of the instrument, do not use any abrasive or chemical cleaning agents.

Flat Panel Display Cleaning. The display is a soft plastic display and must be treated with care during cleaning.



CAUTION. *Imported cleaning agents or methods can damage the flat panel display.*

Avoid using abrasive cleaners or commercial cleaners to clean the display surface.

Avoid spraying liquids on the display surface.

Avoid scrubbing the display with excessive force.

1. Clean the flat panel display surface by gently rubbing the display with a clean-room wipe (such as Wypall Medium Duty Wipes, #05701, available from Kimberly-Clark Corporation).
2. If the display is very dirty, moisten the wipe with distilled water or a 75% isopropyl alcohol solution and gently rub the display surface. Avoid using excess force or you may damage the plastic display surface.



CAUTION. *To prevent getting moisture inside the instrument during external cleaning, use only enough liquid to dampen the cloth or applicator.*

Inspection — Interior. Inspect and clean the interior if it appears that the instrument may have been damaged or exposed to an unusually dirty environment.

To access the inside of the instrument for inspection and cleaning, refer to the *Removal and Installation Procedures* in this section.

Inspect the internal portions of the instrument for damage and wear, using Table 4-2 as a guide. Defects should be repaired immediately.



CAUTION. *To prevent damage from electrical arcing, ensure that circuit boards and components are dry before applying power to the instrument.*

Table 4-2: Internal inspection checklist

Item	Inspect for	Repair action
Front and Rear Case	Cracks or deformations. Scratched lettering or display filter. Loose connectors or labels.	Repair or replace defective hardware.
Circuit boards	Loose, broken, or corroded solder connections. Burned circuit boards. Burned, broken, or cracked circuit-run plating.	Remove failed module and replace with a new module.
Solder connections	Cold solder or rosin joints.	Resolder joint and clean with ethyl alcohol.
Wiring and cables	Loose plugs or connectors. Burned, broken, or frayed wiring.	Firmly seat connectors. Repair or replace modules with defective wires or cables.
Chassis	Dents, deformations, and damaged hardware.	Straighten, repair, or replace defective hardware.

Cleaning Procedure — Interior. Do the following steps to clean the instrument interior:

1. Blow off dust with dry, low-pressure, deionized air (approximately 9 psi).
2. Remove any remaining dust with a lint-free cloth dampened in isopropyl alcohol (75% solution) and rinse with warm deionized water. (A cotton-tipped applicator is useful for cleaning in narrow spaces and on circuit boards.)

NOTE. *If steps 1 and 2 do not remove all the dust or dirt, please contact Tektronix. (See Contacting Tektronix at the front of this manual.)*

Lubrication. There is no periodic lubrication required for the AWG7000 Series Arbitrary Waveform Generator.

Removal and Installation Procedures

This section contains procedures for removal and installation of all mechanical and electrical modules.

Preparation



WARNING. Only qualified personnel should perform service procedures.

Before performing this or any other procedure in this manual, read the General Safety Summary and Service Safety Summary found at the beginning of this manual.

To prevent damage to the instrument components, read Preventing ESD in this section.

Before doing any procedure in this section, disconnect the power cord from the line voltage source.

This section contains the following items:

- This preparatory information that you need to properly do the following procedures.
- List of tools required to remove and disassemble all modules.
- Procedures for removal and reinstallation of the modules.

NOTE. Read *Equipment Required* for a list of the tools needed to remove and install modules in this instrument. See Table 4-3, on page 4-10. Read the cleaning procedure before disassembling the instrument for cleaning.

Adjustment after repair

After the removal and replacement of a module due to electrical failure, perform the adjustment procedures. Refer to the *Adjustment Procedures* section.

List of Modules

The *Replaceable Parts* section provides a list of all replaceable modules. Any electrical or mechanical module, assembly, or part listed in the parts list is referred to as a module.

Summary of Procedures

Disassembly for replacement is best achieved by removing and replacing the modules in a specific order. Complete disassembly is best achieved by the following procedures in the order given in Figure 4-1 and Figure 4-2.

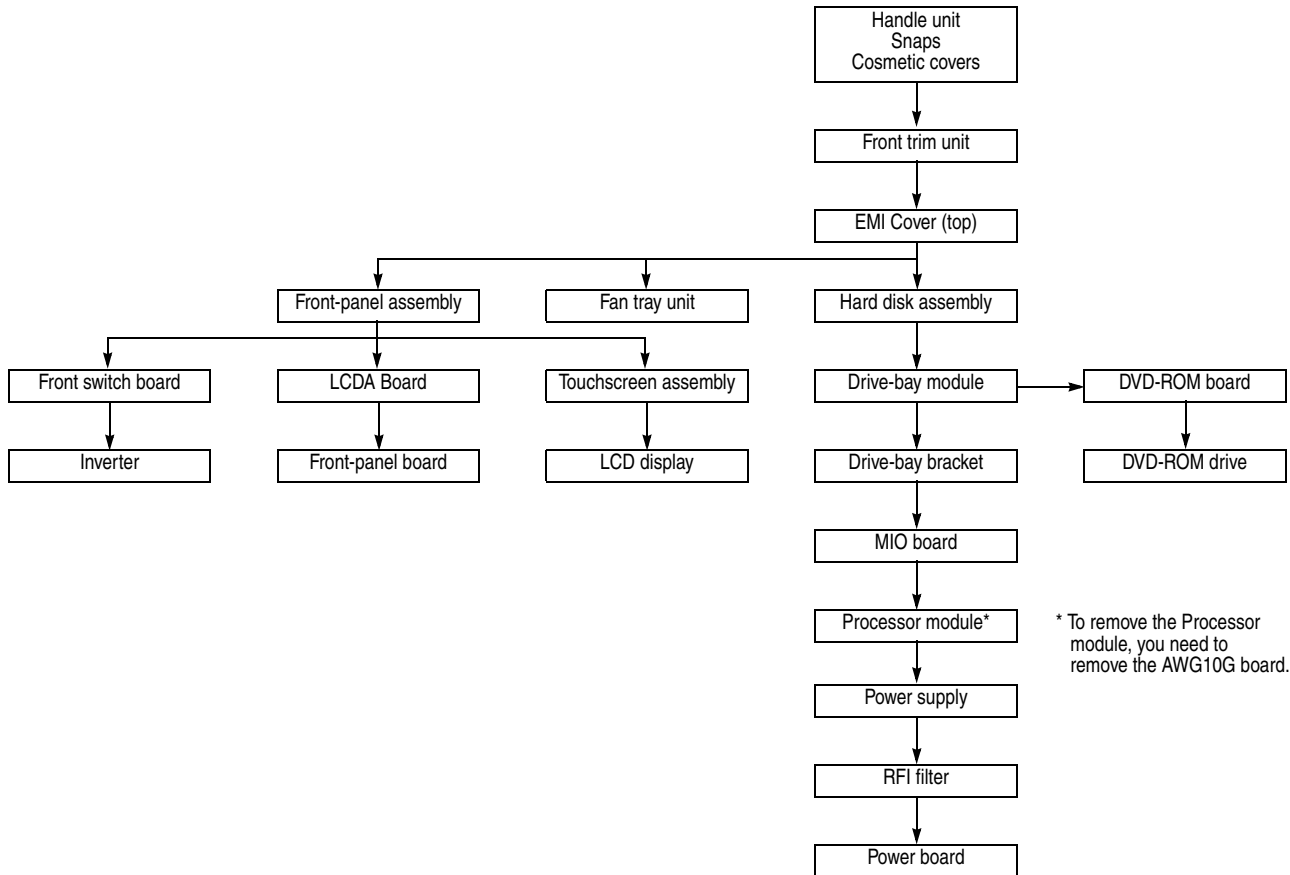

Figure 4-1: Disassembly procedures for external modules and internal modules (top)

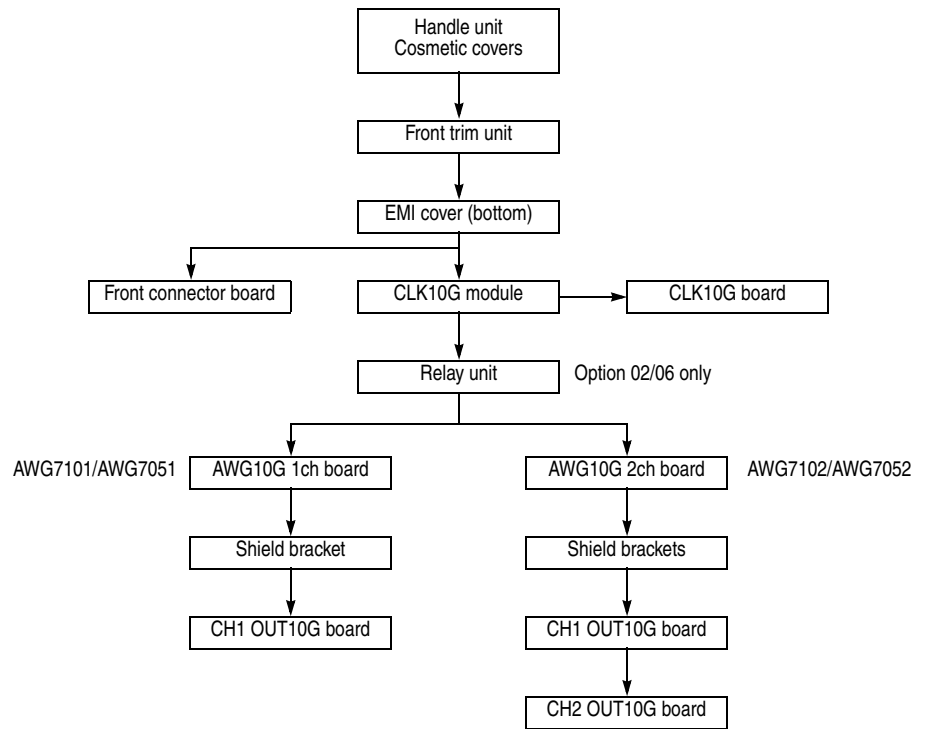

Figure 4-2: Disassembly procedures for internal modules (bottom)

Required Equipment

Most modules in the instrument can be removed with a screwdriver handle mounted with a size T-15, Torx screwdriver tip. All equipment required to remove and reinstall the modules is listed in Table 4-3.

Table 4-3: Tools required for module removal and reinstall

Item #	Name	Description	General tool #
1.	Screwdriver handle	Accepts Torx-driver bits	620-440
2.	T-15 Torx tip	Torx-driver bit for T-15 size screw heads	640-247
3.	T-10 Torx tip	Torx-driver bit for T-10 size screw heads	
4.	T-20 Torx tip	Torx-driver bit for T-20 size screw heads	
5.	#1 Phillips screwdriver	Screwdriver for removing #1 size Phillips screws	Standard tool
6.	#2 Phillips screwdriver	Screwdriver for removing #2 size Phillips screws	Standard tool
7.	3/16 inch open-end wrench	Used to remove nut posts	Standard tool
8.	Pliers	Pliers modified for use in SMP cable insertion/extraction	003-1895-00
9.	5/16 inch torque wrench (8.0 in-lbs)	Used to remove SMA cables	
10.	Angle-Tip Tweezers	Used to remove the front-panel knob	Standard tool

Disconnecting and Connecting the SMP cable

When you disconnect or connect the SMP cable, use the pliers specified in Table 4-3 and keep the connector vertical. If excessive sideways force is applied, the connector is damaged.



Connect and disconnect straight



Do not move from side to side.

Figure 4-3: Disconnecting and connecting the SMP cable

Procedures for External Modules

Handle Unit You need a screwdriver with a T-20 Torx tip (items 1 and 4).

Removal. To remove the handle unit, refer to Figure 4-4 on page 4-12 and follow these steps:

1. Remove the two screws securing the handle base bracket to the cosmetic cover.
2. Grasp the bracket and handle away from the cosmetic cover.

Installation. To install, reverse this procedure.

Snaps You need a screwdriver with a T-15 Torx tip (items 1 and 2).

Removal. To remove the snaps, refer to Figure 4-4 on page 4-12 and follow these steps:

1. Remove the four screws securing the snaps to the cosmetic cover.
2. Lift the snaps away from the cosmetic cover.

Installation. To install, reverse this procedure.

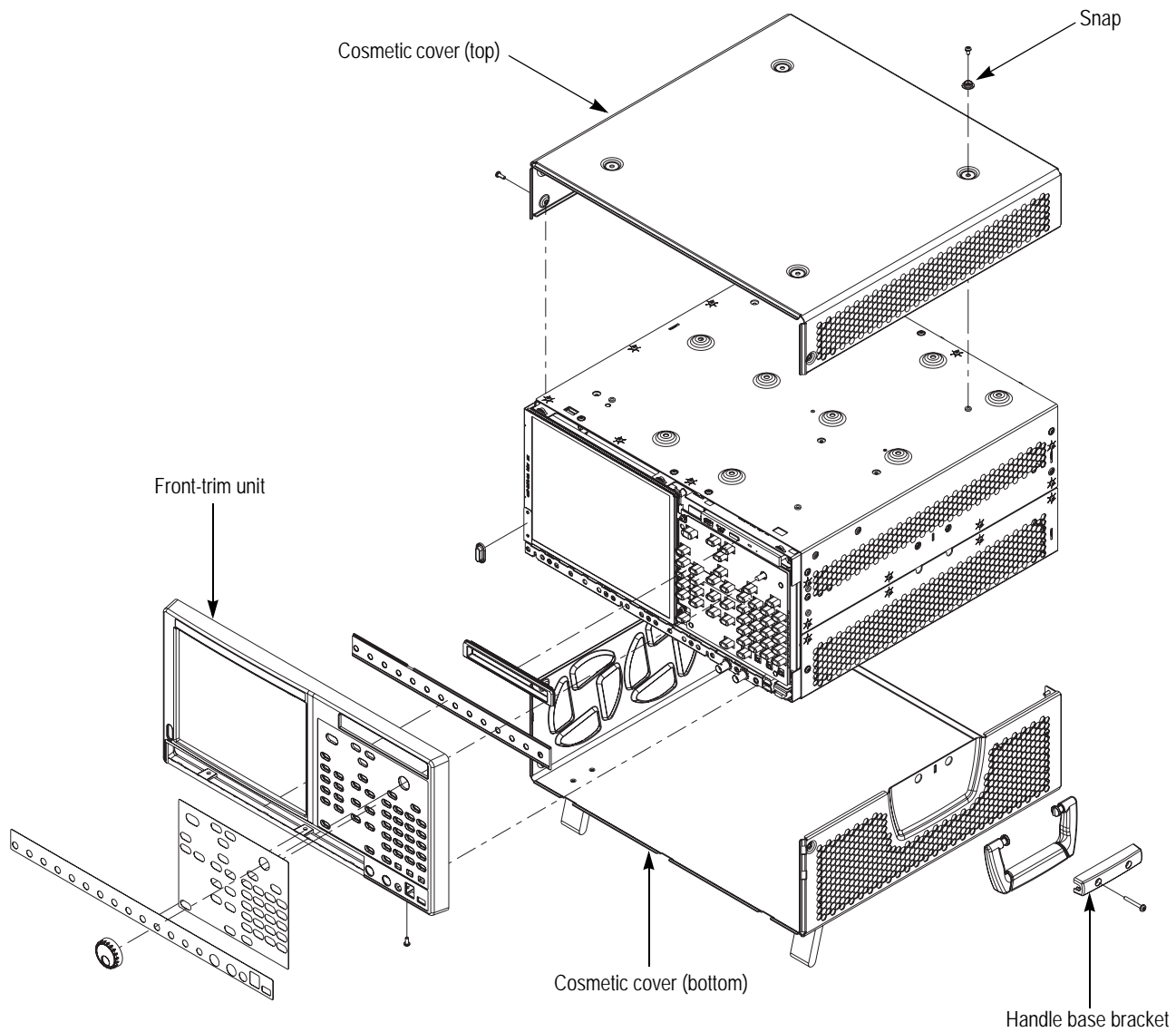

Figure 4-4: Handle, snaps, cosmetic covers, and front-trim unit removal

Cosmetic Cover (Top)

You need a screwdriver with a T-15 Torx tip (items 1 and 2).

Removal. To remove the top cosmetic cover, refer to Figure 4-4 and follow these steps:

1. Remove the snaps.
2. Remove the two screws securing the cosmetic cover to the chassis.
3. Loosen the cover with a detaching tool, such as a flat-blade screwdriver.

4. Tilt the rear side of the cover up, and then pull it off the chassis.

Installation. To install, reverse this procedure.

Cosmetic Cover (Bottom)

You need a screwdriver with a T-15 Torx tip (items 1 and 2).

Removal. To remove the top cosmetic cover, refer to Figure 4-4 and follow these steps:

1. Remove the handle unit.
2. Orient the instrument so its top is down on the work surface and its rear is facing you.
3. Remove the two screws securing the cosmetic cover to the chassis.
4. Loosen the cover with a detaching tool, such as a flat-blade screwdriver.
5. Tilt the rear side of the cover up, then pull it off the chassis.

Installation. To install, reverse this procedure.

Front-Trim Unit

You need a screwdriver with a T-15 Torx tip, and angle-tip tweezers (items 1, 2, and 10).

Removal. To remove the front-trim unit, refer to Figure 4-4 follow these steps:

1. Remove the handle unit, snaps, and cosmetic covers.
2. Orient the instrument so that the rear is on the work surface.
3. Paste a tape to the power switch button so that it will not come off the front trim.
4. Remove the knob by pulling it straight out from the front panel with the angle-tip tweezers.
5. Remove the three screws at the bottom of the front trim.
6. Grasp the bottom side of the front trim, and pull off the bottom side of it by loosening the DVD drive part.
7. The upper part of the chassis has three projections. The front trim fits in these projections. When removing the front trim, grasp its back edge and flex it upward before pulling it forward.

Installation. To install, reverse this procedure.

EMI Covers

You need a screwdriver with a T-15 Torx tip (items 1 and 2).

Removal. To remove the EMI covers, refer to Figure 4-5 on page 4-14 and follow these steps:

1. Remove the handle unit, snaps, cosmetic covers, and front-trim unit.

2. Remove the top cover:
 - a. Orient the instrument so that the bottom is on the work surface.
 - b. Remove the 14 screws securing the top EMI cover to the chassis.
 - c. Lift the cover off the chassis.
3. Remove the bottom cover:
 - a. Orient the instrument so that the top is on the work surface.
 - b. Remove the 12 screws securing the bottom EMI cover to the chassis.
 - c. Lift the cover off the chassis.

Installation. To install, reverse this procedure.

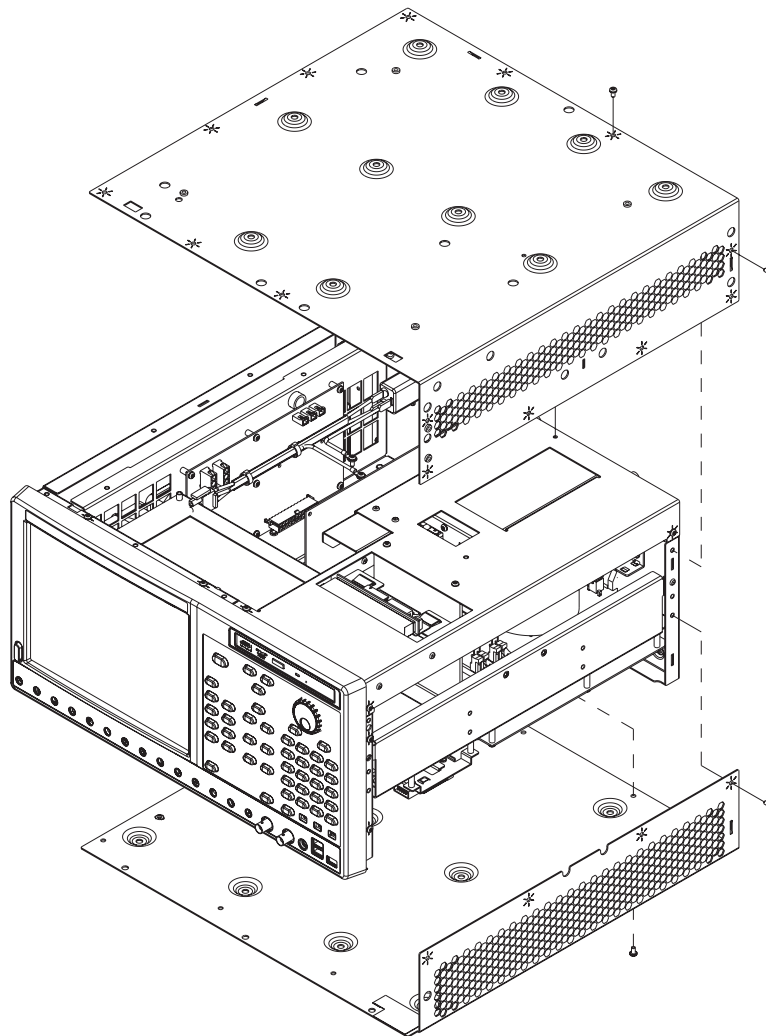

Figure 4-5: EMI covers removal

Hard Disk Assembly

Removal. To remove the removable hard disk assembly, follow these steps:

1. Orient the instrument so that its bottom is down on the work surface and its rear is facing you.
2. Loosen the two thumb screws securing the hard disk assembly to the instrument.
3. Holding the screw heads, pull out the removable hard disk assembly carefully.

Installation. To install, reverse this procedure.



CAUTION. *The hard disk drive is extremely susceptible to static-discharge damage, shock, dust and so on. When you store a removable hard disk assembly, put it into an anti-static plastic bag to protect it.*

Fan Tray Unit

You need a screwdriver with a T-15 Torx tip and a #2 Phillips screwdriver (items 1, 2, and 6).

Removal. To remove the fan tray unit, refer to Figure 4-6 on page 4-16 and follow these steps:

1. Remove the handle unit, snaps, cosmetic covers, front-trim unit, and EMI covers.
2. Disconnect the fan cables from J300, J302, and J304 on the Power board.
3. Remove the four screws securing the fan tray unit to the chassis.
4. Lift the fan tray unit away from the chassis.
5. Use a #2 Phillips screwdriver to remove the 12 screws securing the fans to the fan bracket.

Install. To install, reverse this procedure.

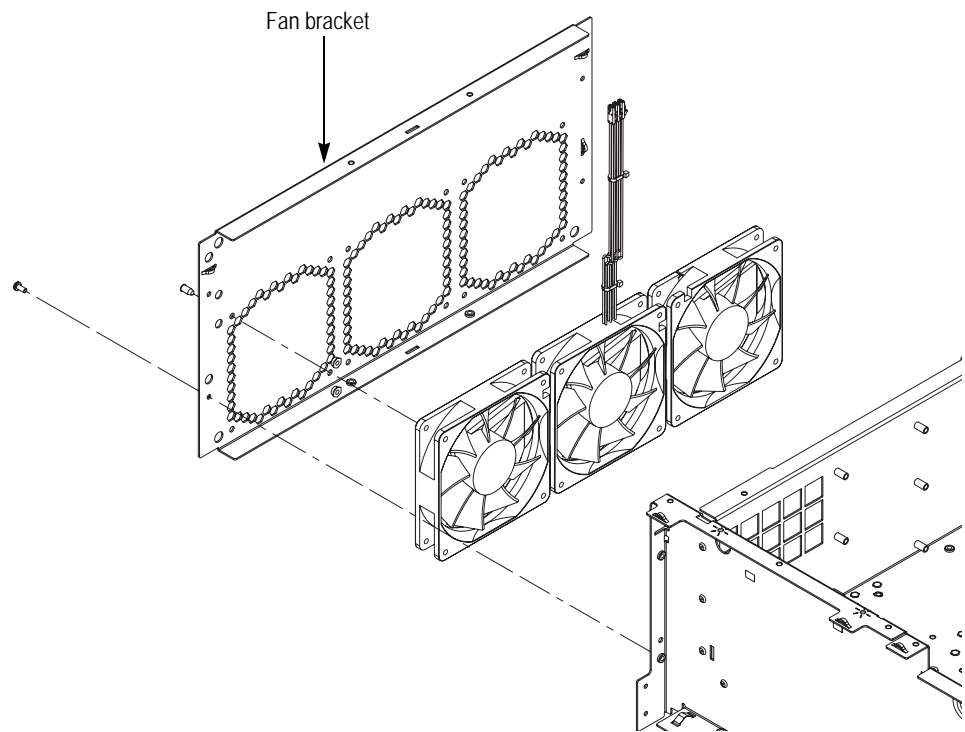

Figure 4-6: Fan tray unit removal

Front-Panel Unit

You need a screwdriver with a T-15 Torx tip (items 1 and 2).

Removal. To remove the front-panel unit, refer to Figure 4-7 and follow these steps:

1. Remove the handle unit, snaps, cosmetic covers, front-trim unit, and EMI covers.
2. Orient the instrument so that the rear is on the work surface.
3. Remove the seven screws securing the front-panel bracket to the chassis.
4. Grasp the front-panel assembly and pull it forward.
5. Disconnect the cable from J100 on the LCDA board.
6. Disconnect the cable from J300 on the LCDA board.
7. Disconnect the cable from J100 on the Front Switch board.

Installation. To install, reverse this procedure.

Front-Panel Assembly

You need a a screwdriver with a T-15 Torx tip (items 1 and 2).

Removal. To remove the front-panel assembly, refer to Figure 4-7 and follow these steps:

1. Remove the cosmetic covers, front-trim unit, and EMI covers.
2. Remove the LCDA board and Front Panel board:
 - a. Remove the four screws securing the LCDA board and Front Panel board to the front-panel bracket.
 - b. Remove the cables from J110, J160, and J200.
 - c. Lift the boards away from the front-panel bracket.
3. Remove the touch screen module:
 - a. Remove the two screws securing the touch screen module to the front-panel bracket.
 - b. Disconnect the cable from J200 on the LCDA board.
 - c. Lift the touch screen module away from the front-panel bracket.

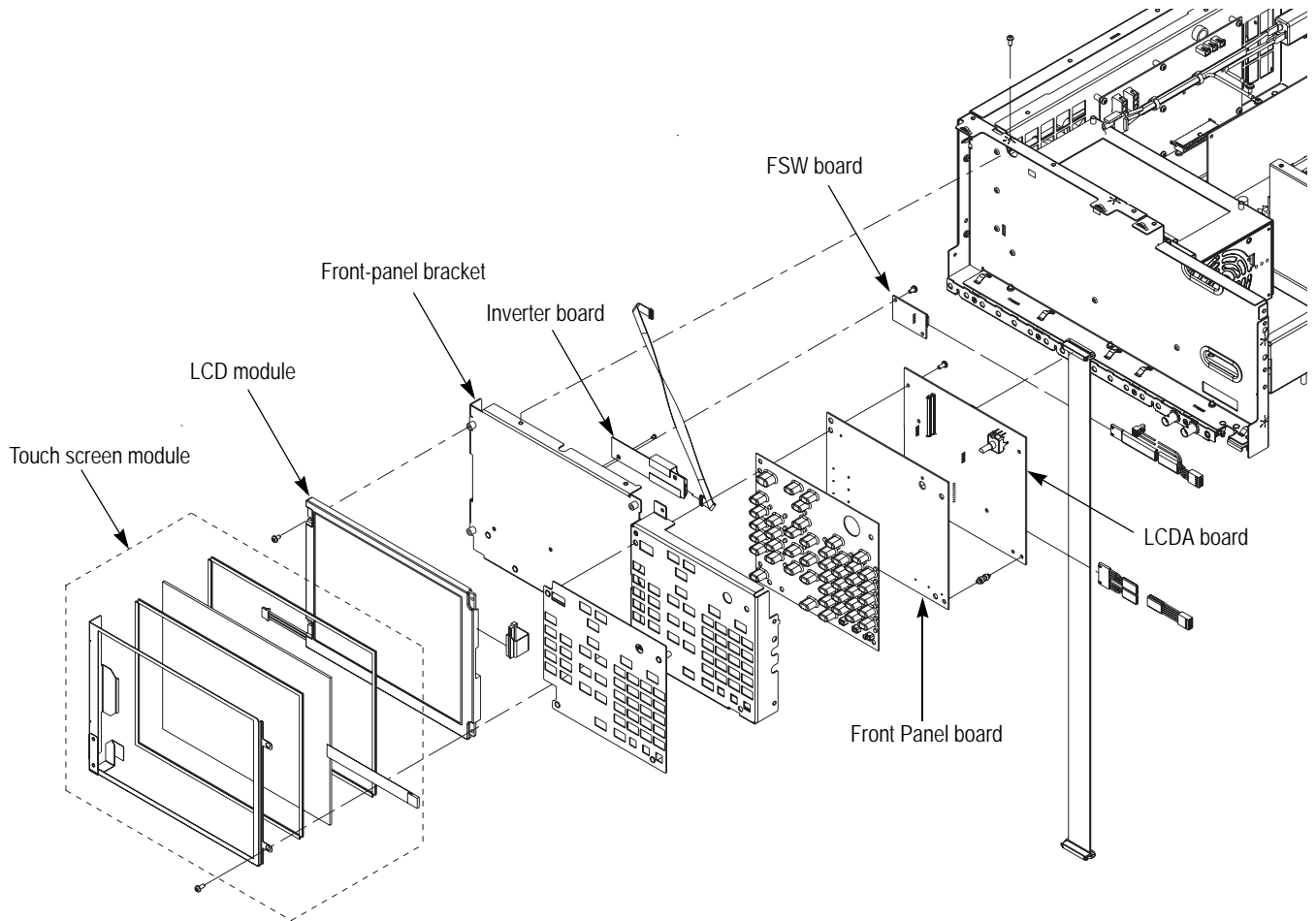

Figure 4-7: Disassembly of front-panel assembly

4. Remove the LCD module:
 - a. Remove the four screws securing the LCD module to the front-panel bracket.
 - b. Disconnect the cable from J110 on the LCDA board.
 - c. Disconnect the cable from CN2 on the Inverter board.
 - d. Lift the LCD module away from the front-panel bracket.
5. Disassemble the front-panel assembly components, using Figure 4-7 as a guide.

Installation. To install, reverse this procedure.

Procedures for Internal Modules (Upper)

Drive-Bay Module You need a screwdriver with a T-15 Torx tip (items 1 and 2).

Removal. To remove the drive-bay module, refer to Figure 4-8 and follow these steps:

1. Remove the handle unit, snaps, cosmetic covers, front-trim unit, EMI covers, and hard disk assembly.
2. Orient the instrument so that the bottom is on the work surface.
3. Remove the eight screws securing the drive-bay module to the chassis.
4. Disconnect the cables from J101 and J104 on the Power board.
5. Disconnect the cables from J5J1 and J7J1 on the Processor board.
6. Lift the drive-bay module away from the chassis.

Installation. To install, reverse this procedure.

DVD-ROM Drive You need a screwdriver with a T-15 Torx tip and a #1 Phillips screwdriver (items 1, 2, and 5).

Removal. To remove the DVD-ROM drive, refer to Figure 4-8 and follow these steps:

1. Remove the handle unit, snaps, cosmetic covers, front-trim unit, EMI covers, hard disk assembly, and drive-bay module.
2. Remove the two screws securing the DVD-ROM bracket to the drive-bay chassis.
3. Slide the DVD-ROM drive with bracket out from the drive-bay chassis.
4. Remove the four screws securing the DVD-ROM drive to the bracket.

Installation. To install, reverse this procedure.

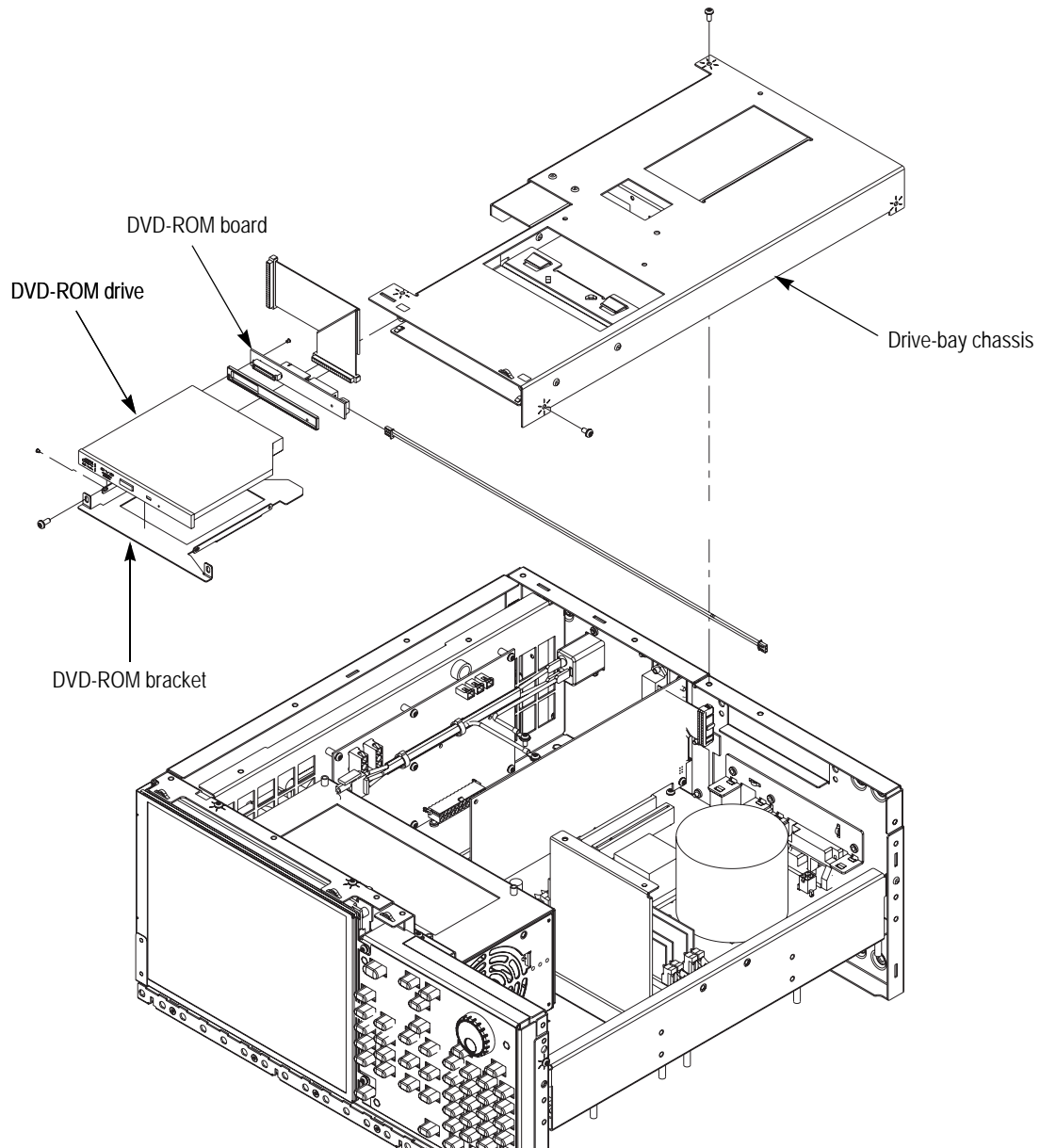

Figure 4-8: Drive module removal

DVD-ROM Board

You need a #1 Phillips screwdriver (item 5).

Removal. To remove the DVD-ROM board, refer to Figure 4-8 on page 4-19 and follow these steps:

1. Remove the handle unit, snaps, cosmetic cover, front-trim unit, EMI covers, hard disk assembly, and drive-bay module.
2. Remove the two screws securing the DVD-ROM board to the DVD-ROM drive.
3. Disconnect the cable from J1 on the DVD-ROM board.
4. Disconnect the interface cable on the DVD-ROM board.
5. Lift the board away from the DVD-ROM drive.

Installation. To install, reverse this procedure.

Multi-Input/Output Board

You need a screwdriver with a T-15 Torx tip (items 1 and 2).

Removal. To remove the Multi-Input/output board, refer to Figure 4-9 and follow these steps:

1. Remove the handle unit, snaps, cosmetic covers, front-trim unit, and EMI covers.
2. Orient the instrument so that the bottom is on the work surface and the rear is facing you.
3. Disconnect the cables from J360, J670, J680, and J681 on the Multi-Input/Output board.
4. Remove the six screws securing the Multi-Input/Output board to the chassis.
5. Carefully pull up on the board to loosen it from the Processor board.
6. Lift the board away from the chassis.

Installation. To install, reverse this procedure.

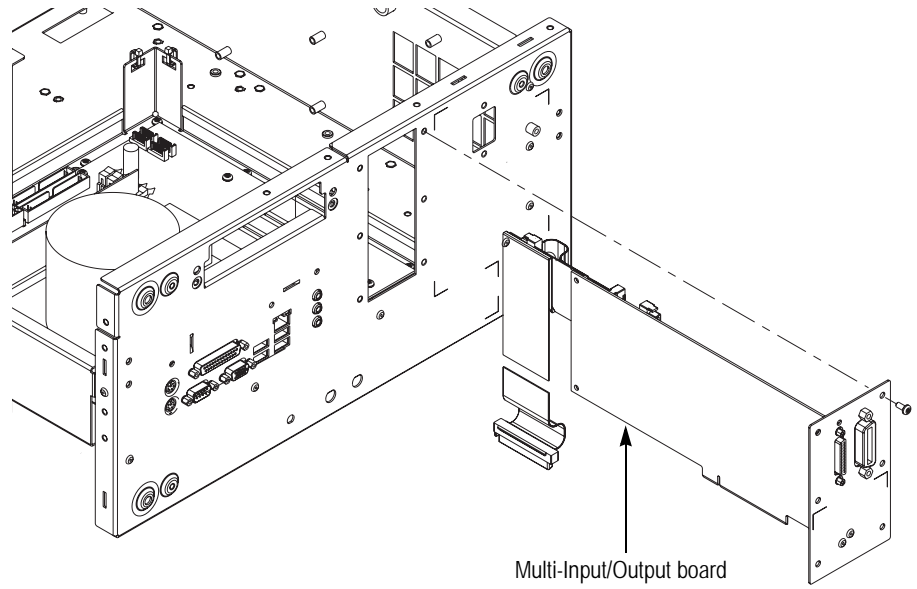

Figure 4-9: Multi-Input/Output board removal

Processor Module You need a screwdriver with a T-15 Torx tip, and a 3/16 inch open-end wrench (items 1, 2, and 7).

NOTE. Before you remove the processor module, you need to disconnect the ribbon cable at J1000 from the AWG10G board. Refer to AWG10G 1 CH Board on page 4-33 or AWG10G 2 CH Board on page 4-34.

Removal. To remove the processor module, refer to Figure 4-10 and follow these steps:

1. Remove the handle unit, snaps, cosmetic covers, front-trim unit, EMI covers, drive-bay module, and Multi-Input/Output board.
2. Orient the instrument so that the bottom is on the work surface.
3. Remove the two screws securing the drive-bay bracket to the processor tray.
4. Lift the drive-bay bracket away from the processor tray.
5. Remove the three screws securing the connector bracket to the rear panel.
6. Lift the connector bracket away from the rear panel.
7. Remove the six mounting posts securing the VIDEO connector, COM 1 connector, and PARALELL PORT connector to the chassis.
8. Remove the eight screws securing the Processor tray to the chassis.
9. Disconnect these cables:
 - The cable from the Power board at J2A1, J2A2, and J2J1.
 - The cable from the LCDA board at J8H1.
 - The cable from the Front Connector board at J8G2.
 - The cable from the Front Switch board and Multi-Input/Output board at J8J3.
10. Carefully lift up and slide the processor module away from the chassis.

Installation. To install, reverse this procedure.

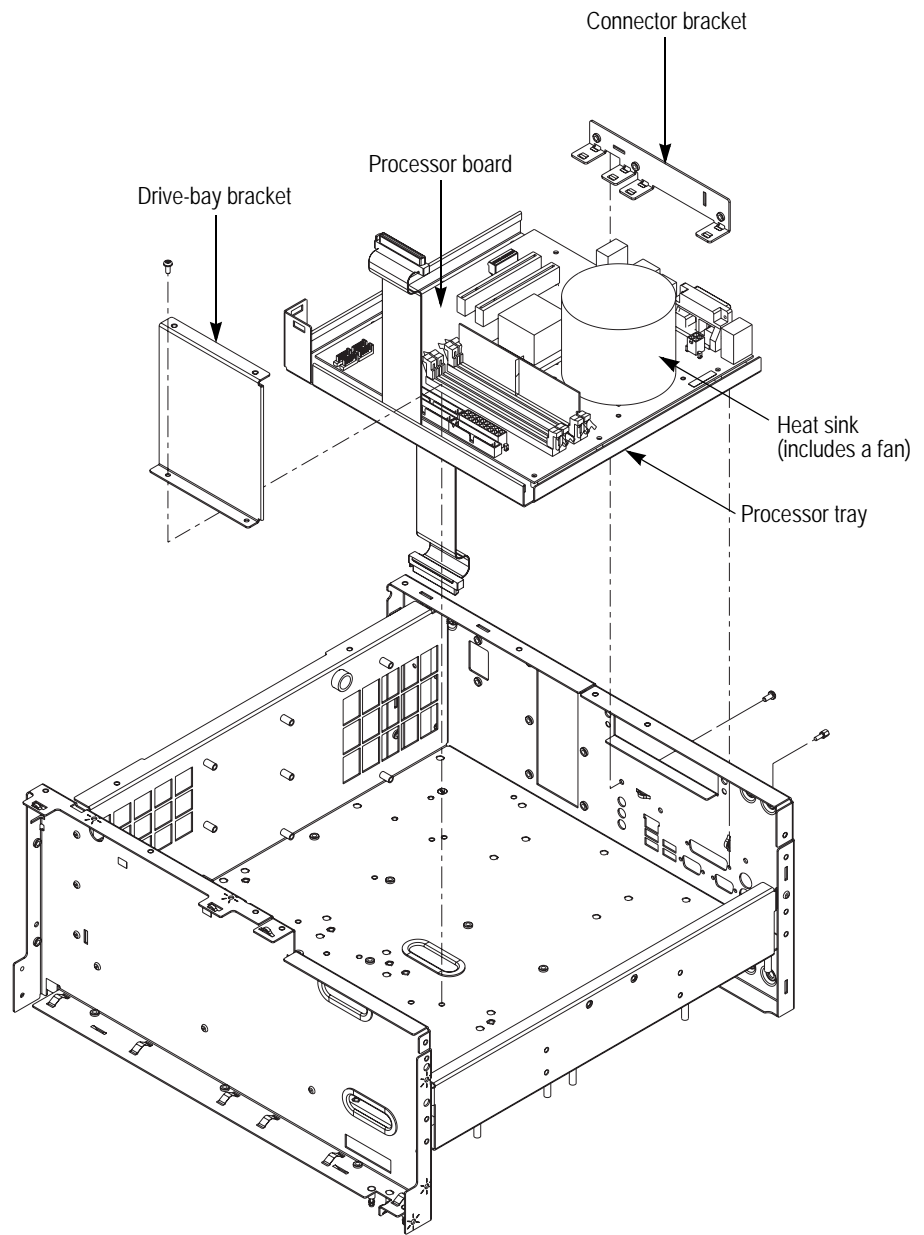

Figure 4-10: Processor module removal

Power Supply You need a screwdriver with a T-15 Torx tip (items 1 and 2).

Removal. To remove the power supply, refer to Figure 4-11 and follow these steps:

1. Remove the handle unit, snaps, cosmetic covers, front-trim unit, EMI covers, drive-bay module, and Multi-Input/Output board.
2. Orient the instrument so that the bottom is on the work surface.
3. Remove the six screws securing the power supply bracket to the chassis.
4. Disconnect the cable from J611 on the Power board.
5. Remove the three screws securing the bracket to the power supply.
6. Carefully slide the module to loosen it from the Power board.
7. Lift the power supply up out of the chassis.
8. Lift the bracket up out of the chassis.

Installation. To install, reverse this procedure.

RFI Filter You need a screwdriver with a T-15 Torx tip (items 1 and 2).

Removal. To remove the power supply, refer to Figure 4-11 and follow these steps:

1. Remove the handle unit, snaps, cosmetic covers, and EMI covers.
2. Orient the instrument so that the bottom is on the work surface.
3. Disconnect the cable from J600 on the Power board.
4. Remove the two screws securing the ground leads to the chassis.
5. Remove the two screws securing the RFI filter to the chassis.
6. Pull the RFI filter away from the chassis.

Installation. To install, reverse this procedure.

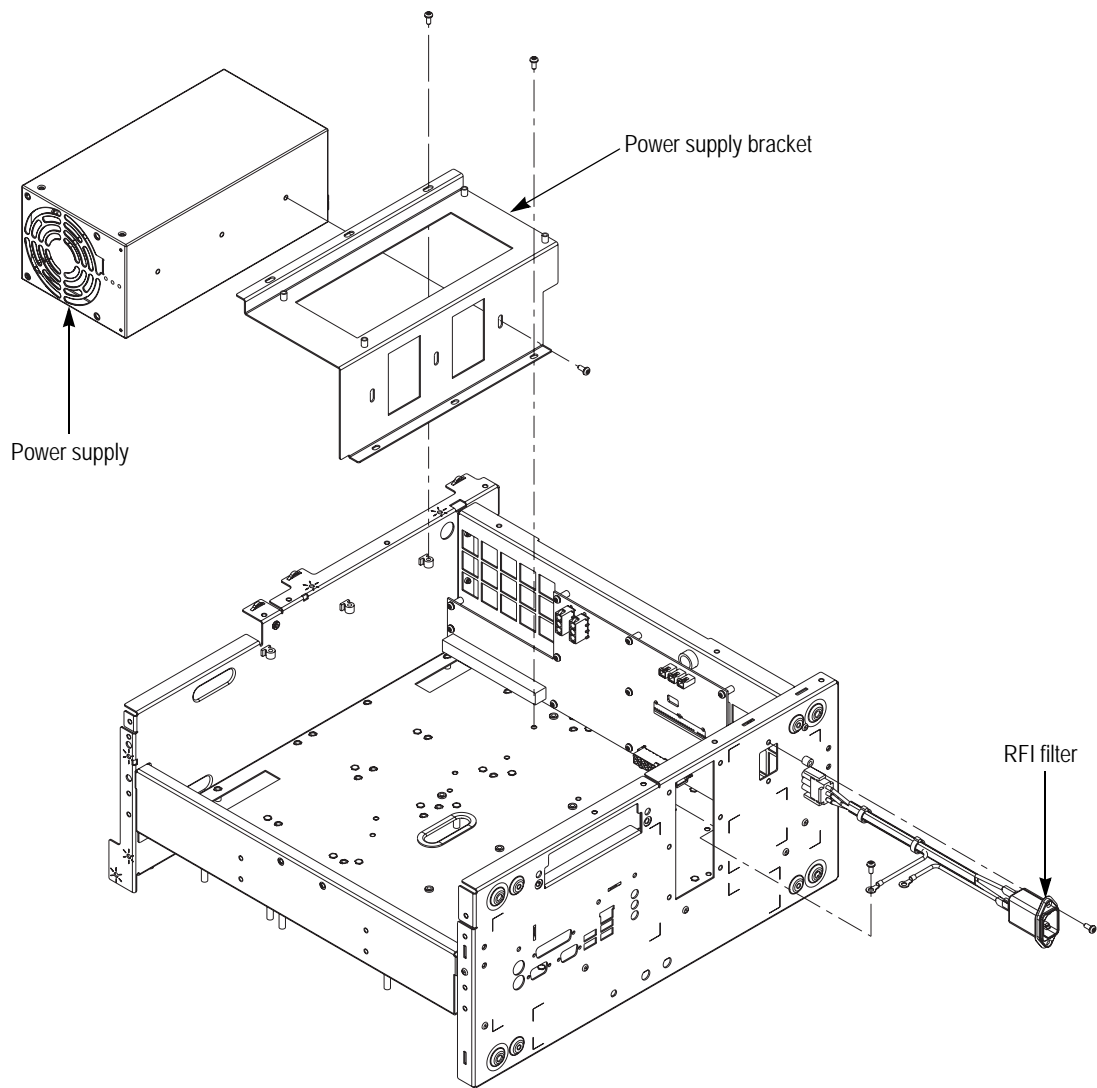

Figure 4-11: Power Supply and RFI filter removal

Power Board You need a screwdriver with a T-15 Torx tip (items 1 and 2).

Removal. To remove the Power board, refer to Figure 4-12 and follow these steps:

1. Remove the handle unit, snaps, cosmetic covers, front-trim unit, EMI covers, drive-bay module, power supply, Multi-Input/Output board, and Processor board.
2. Orient the instrument so that the bottom is on the work surface.
3. Disconnect the cables from J102, J103, J120, J300, J302, J304, J600, and J611 on the Power board.
4. Remove the 10 screws securing the Power board to the chassis.
5. Lift the board away from the chassis.

Installation. To install, reverse this procedure.

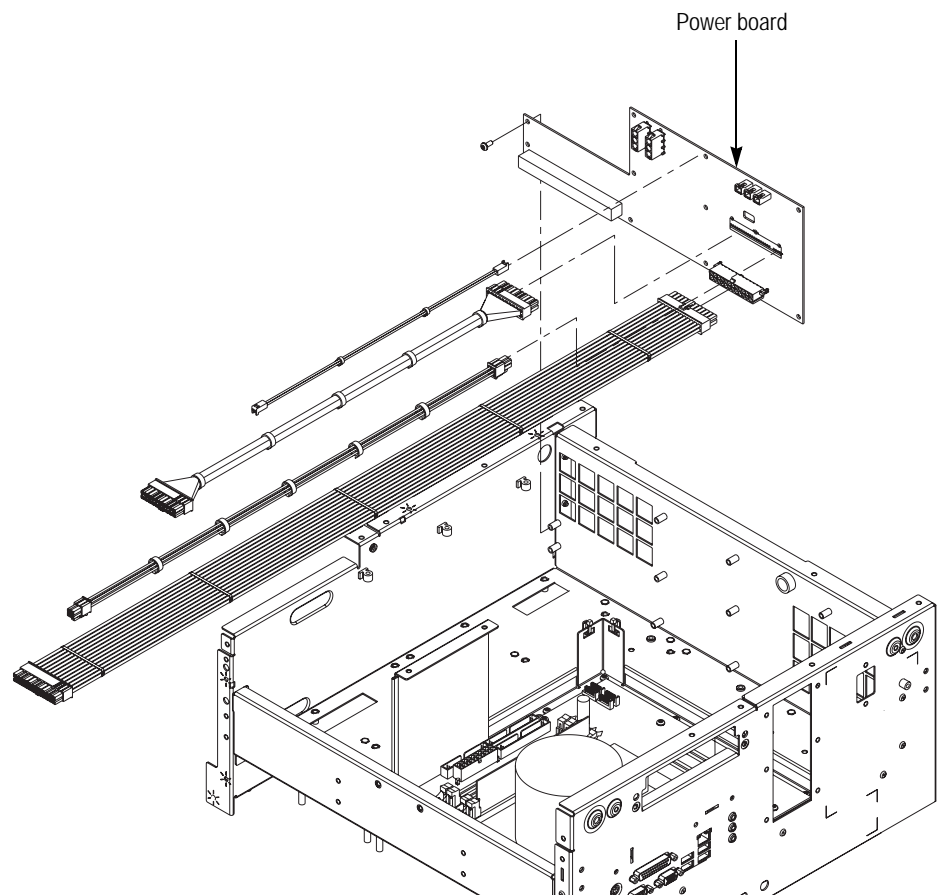

Figure 4-12: Power board removal

Procedures for Internal Modules (Lower)

Front Connector Board You need a screwdriver with a T-15 Torx tip (items 1 and 2).

Removal. To remove the Front Connector board, refer to Figure 4-13 on page 4-28 and follow these steps:

1. Remove the handle unit, snaps, cosmetic covers, front-trim unit, and EMI covers.
2. Orient the instrument so that the top is on the work surface.
3. Disconnect the cables from J100 and J200 on the Front Connector board.
4. Remove the screw securing the Front Connector board to the chassis.
5. Grasp the board and pull it gently away from the chassis.

Installation. To install, reverse this procedure.

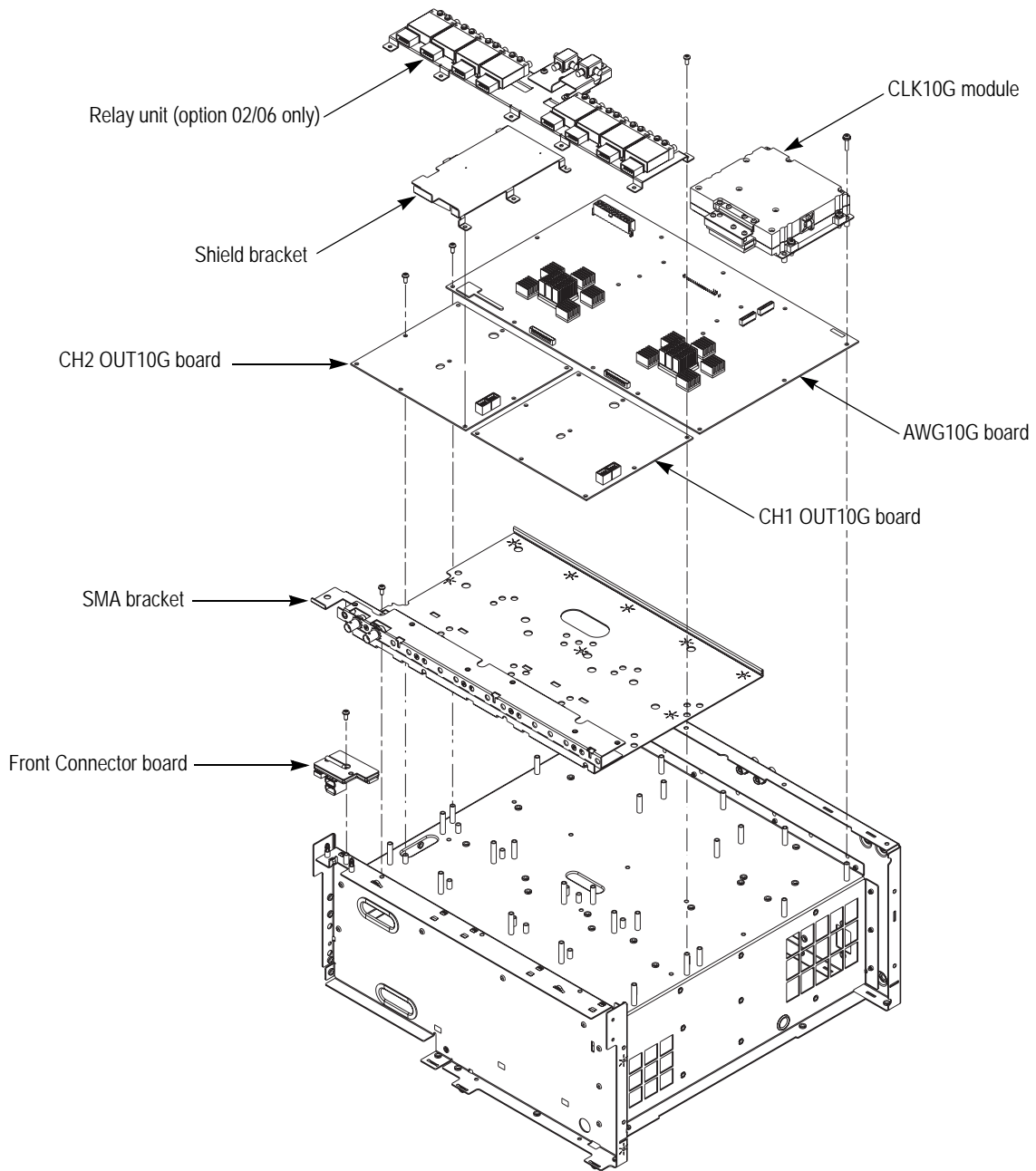

Figure 4-13: Front Connector board, CLK10G module, relay unit, AWG10G board removal

CLK10G Module

You need a screwdriver with a T-15 Torx tip, pliers, and a 5/16 inch torque wrench (items 1, 2, 8, and 9).

Removal. To remove the CLK10G module, refer to Figure 4-13 and follow these steps:

1. Remove the handle unit, snaps, cosmetic covers, front-trim unit, and EMI covers.
2. Orient the instrument so that the top is on the work surface.
3. Disconnect the cable from J150A (and J150B for 2 channel models) on the AWG10G board.
4. Disconnect the cables from the 10 MHz Reference Output connector and the Reference Clock Input connector.
5. Use a 5/16 inch torque wrench to remove the External Clock Input connector from the rear panel.
6. Remove the four screws securing the CLK10G module to the chassis.
7. Carefully pull up on the module to loosen it from the AWG board.
8. Lift the module away from the chassis.

Installation. To install, reverse this procedure.

CLK10G Board

You need a #1 Phillips screwdriver and a 5/16 inch torque wrench (items 5 and 9).

Removal. To remove the CLK10G board, refer to Figure 4-14 on page 4-30 and follow these steps:

1. Remove the five screws securing the shield cover to the top shield case.
2. Lift the shield cover away from the top shield case.
3. Disconnect the cables from J3320 and J3350 (and J3351 for 2 channel models) on the CLK10G board.
4. Use a 5/16 inch torque wrench to remove the two SMA cables from J3110 and J3120 on the CLK10G board.
5. Remove the 10 screws securing the top shield case to the bottom shield case.
6. Lift the top shield case away from the bottom shield case.
7. Lift the CLK10G board away from the bottom shield case.

Installation. To install, reverse this procedure.

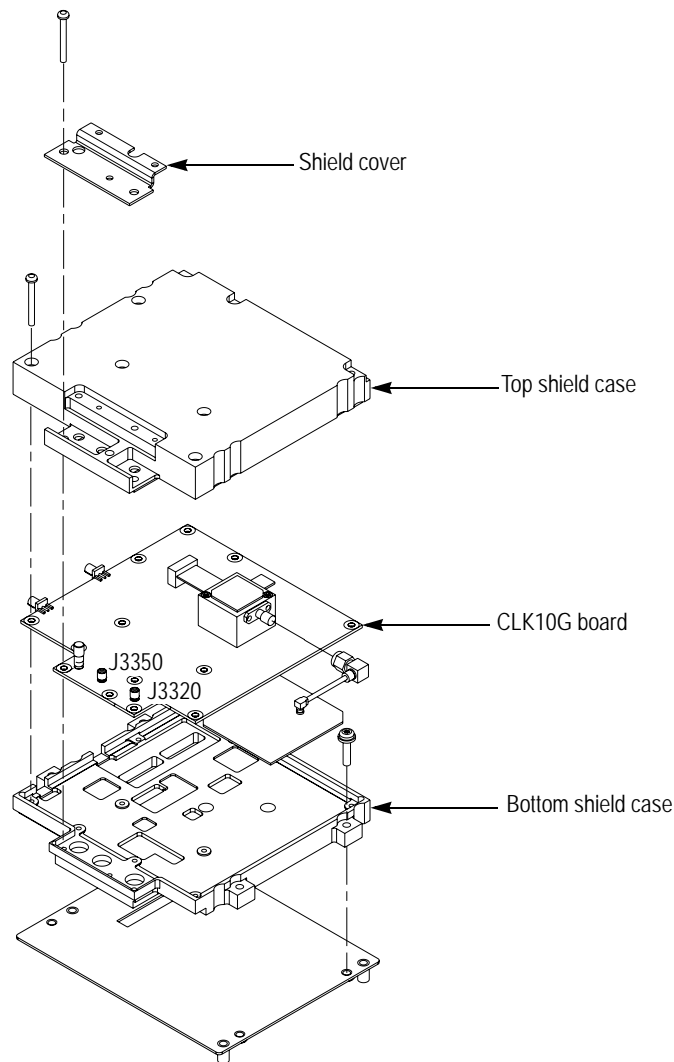

Figure 4-14: Disassembly of the CLK10G module

Relay Unit (for Option 02)

You need a screwdriver with a T-15 Torx tip and a 5/16 inch torque wrench (items 1, 2, and 9).

Removal. To remove the relay unit, refer to Figure 4-13 on page 4-28 and follow these steps:

1. Remove the handle unit, snaps, cosmetic covers, front-trim unit, and EMI covers.
2. Orient the instrument so that the top is on the work surface.

3. Use a 5/16 inch torque wrench to remove the six SMA cables (or 12 SMA cables for 2 channel models) from the relay units.
4. Disconnect the cable (or two cables for 2 channel models) from the relay units.
5. Remove the 10 screws securing the relay unit to the chassis.
6. Lift the relay unit away from the chassis.

Installation. To install, reverse this procedure. See Figure 4-15 for cable connections.

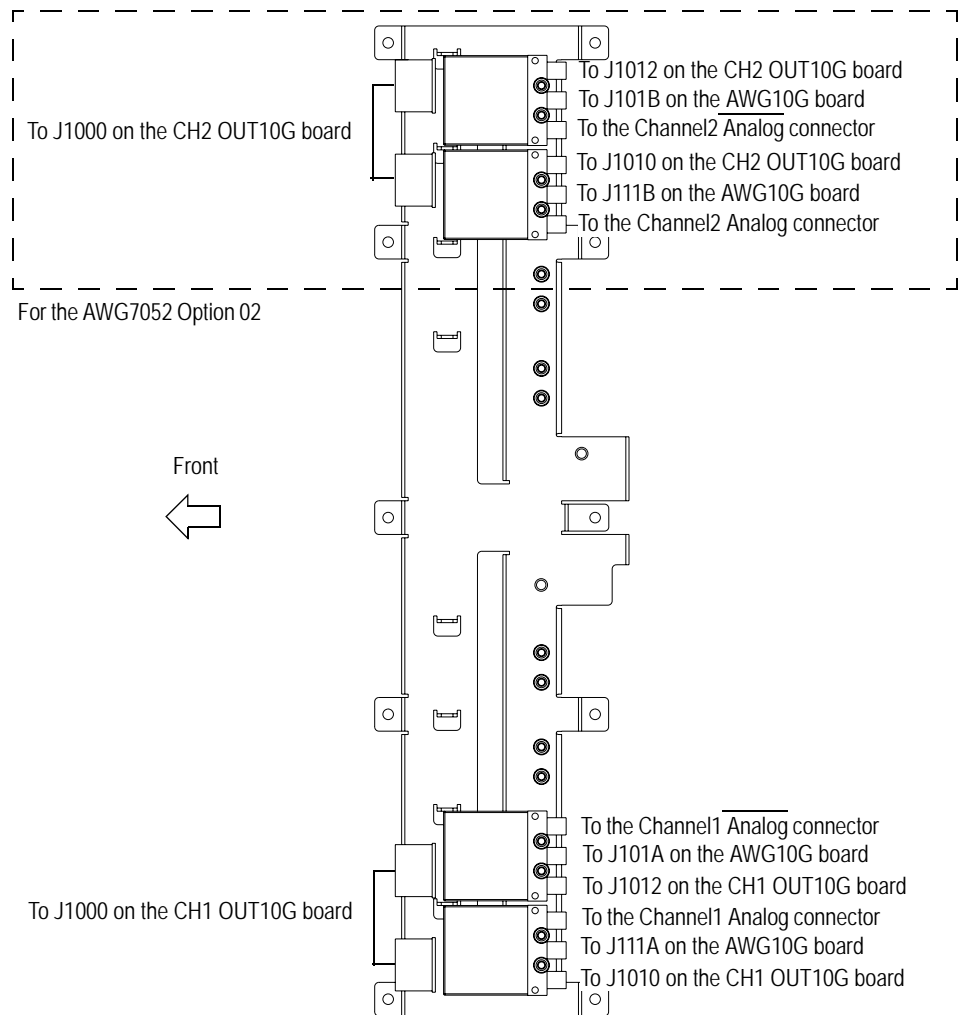

Figure 4-15: Relay unit cable connection for option 02

Relay Unit (for Option 06)

You need a screwdriver with a T-15 Torx tip and a 5/16 inch torque wrench (items 1, 2, and 9).

Removal. To remove the relay unit, refer to Figure 4-13 on page 4-28 and follow these steps:

1. Remove the handle unit, snaps, cosmetic covers, front-trim unit, EMI covers.
2. Orient the instrument so that the top is on the work surface.
3. Use a 5/16 inch torque wrench to remove the 14 SMA cables from the relay units.
4. Disconnect the four cables from the relay units.
5. Remove the 10 screws securing the relay unit to the chassis.
6. Lift the relay unit away from the chassis.

Installation. To install, reverse this procedure. See Figure 4-16 for cable connection.

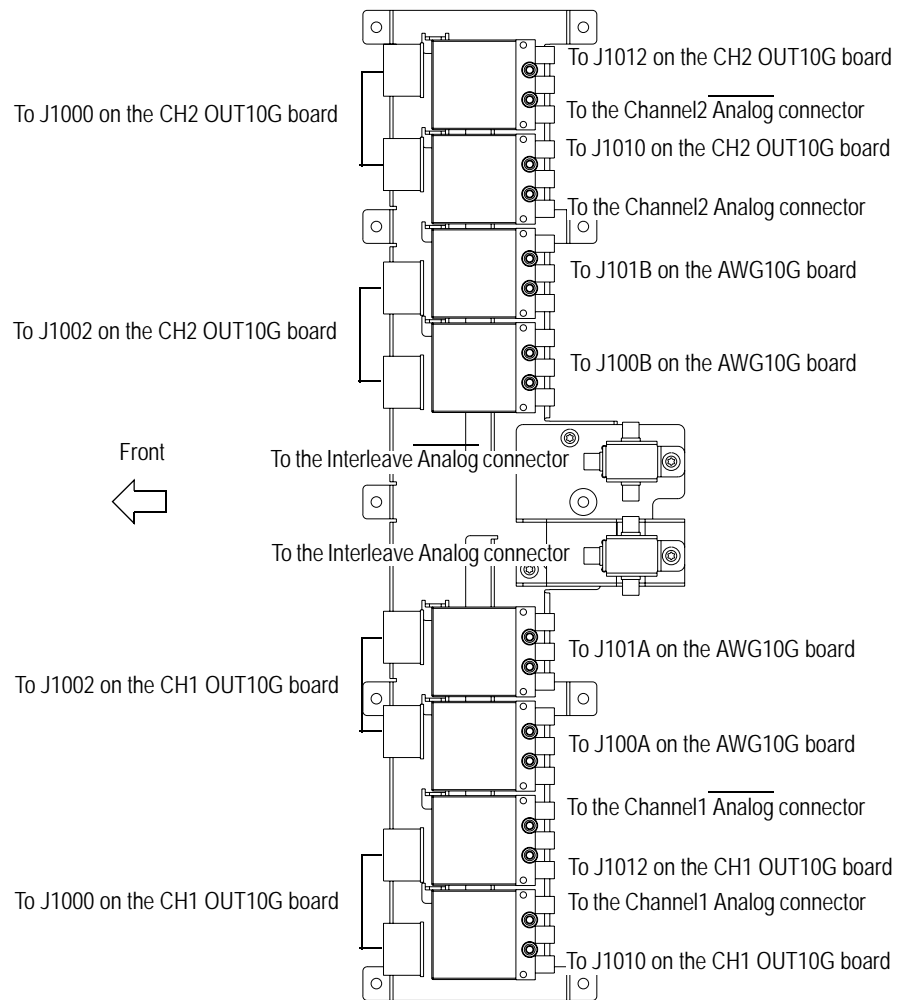

Figure 4-16: Relay unit cable connection for option 06

AWG10G 1 CH Board

You need a screwdriver with a T-15 Torx tip and pliers (items 1, 2, and 8).

Removal. To remove the AWG10G 1 channel board, refer to Figure 4-13 on page 4-28 and follow these steps:

1. Remove the handle unit, snaps, cosmetic covers, front-trim unit, EMI covers, CLK10G module, and relay unit (for Option 02).
2. Orient the instrument so that the top is on the work surface.
3. Disconnect the ribbon cables at J1050, J2000, and J5000 from the AWG10G board.
4. Disconnect these cables:
 - The cable at J115A from the AWG10G board to the CH1 OUT10G board (J150).
 - The cable at J116A from the AWG10G board to the CH1 OUT10G board (J170).
 - The cable at J1430 from the AWG10G board to the Trigger Input connector.
 - The cable at J1440 from the AWG10G board to the Event Input connector.
 - The cables from J100, J110, J600, and J700 on the CH1 OUT10G board.
5. Remove the 11 screws securing the AWG10G board to the chassis.
6. Lift the board away from the chassis.
7. Disconnect the ribbon cable at J1000 on the AWG10G board.
8. Disconnect these cables:
 - The cable at J110A from the AWG10G board to the CH1 OUT10G board (J100).
 - The cable at J111A from the AWG10G board to the CH1 OUT10G board (J110).
 - The cable at J100A from the AWG10G board to the CH1 OUT10G board (J600).
 - The cable at J101A from the AWG10G board to the CH1OUT10G board (J700).

Installation. To install, reverse this procedure.

AWG10G 2 CH Board

You need a screwdriver with a T-15 Torx tip and pliers (items 1, 2, and 8).

Removal. To remove the AWG10G 2 channel board, refer to Figure 4-13 on page 4-28 and follow these steps:

1. Remove the handle unit, snaps, cosmetic covers, front-trim unit, EMI covers, CLK10G module, and relay unit (for Option 02 or 06).
2. Orient the instrument so that the top is on the work surface.
3. Disconnect the ribbon cables at J1050, J2000, and J5000 from the AWG10G board.
4. Disconnect these cables:
 - The cable at J115A from the AWG10G board to the CH1 OUT10G board (J150).
 - The cable at J116A from the AWG10G board to the CH1 OUT10G board (J170).
 - The cable at J115B from the AWG10G board to the CH2 OUT10G board (J150).
 - The cable at J116B from the AWG10G board to the CH2 OUT10G board (J170).
 - The cable at J1430 from the AWG10G board to the Trigger Input connector.
 - The cable at J1440 from the AWG10G board to the Event Input connector.
 - The cables from J100, J110, J600, and J700 on the CH1 OUT10G board.
 - The cables from J100, J110, J600, and J700 on the CH2 OUT10G board.
5. Remove the 11 screws securing the AWG10G board to the chassis.
6. Lift the board away from the chassis.
7. Disconnect the ribbon cable at J1000 on the AWG10G board.
8. Disconnect these cables:
 - The cable at J110A from the AWG10G board to the CH1 OUT10G board (J100).
 - The cable at J111A from the AWG10G board to the CH1 OUT10G board (J110).
 - The cable at J100A from the AWG10G board to the CH1 OUT10G board (J600).
 - The cable at J101A from the AWG10G board to the CH1 OUT10G board (J700).
 - The cable at J110B from the AWG10G board to the CH2 OUT10G board (J100).

- The cable at J111B from the AWG10G board to the CH 2 OUT10G board (J110).
- The cable at J100B from the AWG10G board to the CH2 OUT10G board (J600).
- The cable at J101B from the AWG10G board to the CH2 OUT10G board (J700).

Installation. To install, reverse this procedure.

CH1 OUT10G Board

You need a screwdriver with a T-15 Torx tip and pliers (items 1, 2, and 8).

Removal. To remove the CH1 OUT10G board, refer to Figure 4-13 on page 4-28 and follow these steps:

1. Remove the handle unit, snaps, cosmetic covers, front-trim unit, EMI covers, relay unit (for Option 02 or 06), and AWG10G board.
2. Orient the instrument so that the top is on the work surface.
3. Remove the five screws securing the shield bracket to the chassis.
4. Lift the bracket away from the chassis.
5. Disconnect the ribbon cable at J500 from the CH1 OUT10G board.
6. Disconnect these cables:

NOTE. For Option 02 or 06, there are no cable connections at J600 and J700 on the CH1 OUT10G board.

- The cable at J600 from the CH1 OUT10G board to the AWG10G board (J100A).
- The cable at J700 from the CH1 OUT10G board to the AWG10G board (J101A).
- The cable at J100 from the CH1 OUT10G board to the AWG10G board (J110A).
- The cable at J110 from the CH1 OUT10G board to the AWG10G board (J111A).
- The cable at J150 from the CH1 OUT10G board to the AWG10G board (J115A).
- The cable at J170 from the CH1 OUT10G board to the AWG10G board (J116A).
- The cable at J690 from the CH1 OUT10G board to the Channel 1 Analog connector.
- The cable at J790 from the CH1 OUT10G board to the Channel 1 Analog connector.

- The cable at J120 from the CH1 OUT10G board to the Channel 1 Mkr 1 connector.
 - The cable at J130 from the CH1 OUT10G board to the Channel 1 $\overline{\text{Mkr 1}}$ connector.
 - The cable at J160 from the CH1 OUT10G board to the Channel 1 Mkr 2 connector.
 - The cable at J190 from the CH1 OUT10G board to the Channel 1 $\overline{\text{Mkr 2}}$ connector.
7. Remove the four screws securing the CH1 OUT10G board to the chassis.
 8. Lift the board away from the chassis.

Installation. To install, reverse this procedure.

CH2 OUT10G Board

You need a screwdriver with a T-15 Torx tip and pliers (items 1, 2, and 8).

Removal. To remove the CH2 OUT10G board, refer to Figure 4-13 on page 4-28 and follow these steps:

1. Remove the handle unit, snaps, cosmetic covers, front-trim unit, EMI covers, relay unit (for Option 02 or 06), and AWG10G board.
2. Orient the instrument so that the top is on the work surface.
3. Remove the five screws securing the shield bracket to the chassis.
4. Lift the bracket away from the chassis.
5. Disconnect the ribbon cable at J500 from the CH2 OUT10G board.
6. Disconnect these cables:

NOTE. For Option 02 or 06, there are no cable connections at J600 and J700 on the CH2 OUT10G board.

- The cable at J600 from the CH2 OUT10G board to the AWG10G board (J100B).
- The cable at J700 from the CH2 OUT10G board to the AWG10G board (J101B).
- The cable at J100 from the CH2 OUT10G board to the AWG10G board (J110B).
- The cable at J110 from the CH2 OUT10G board to the AWG10G board (J111B).
- The cable at J150 from the CH2 OUT10G board to the AWG10G board (J115B).
- The cable at J170 from the CH2 OUT10G board to the AWG10G board (J116B).

- The cable at J690 from the CH2 OUT10G board to the Channel 2 Analog connector.
 - The cable at J790 from the CH2 OUT10G board to the Channel 2 Analog connector.
 - The cable at J120 from the CH2 OUT10G board to the Channel 2 Mkr 1 connector.
 - The cable at J130 from the CH2 OUT10G board to the Channel 2 Mkr 1 connector.
 - The cable at J160 from the CH2 OUT10G board to the Channel 2 Mkr 1 connector.
 - The cable at J190 from the CH2 OUT10G board to the Channel 2 Mkr 1 connector.
7. Remove the four screws securing the CH2 OUT10G board to the chassis.
 8. Lift the board away from the chassis.

Installation. To install, reverse this procedure.

Checking Proper Connection of SMP Connectors

After you have replaced the AWG10G board or OUT10G board(s), be sure to verify that the center contacts of the SMP cable connectors do not short the ground terminals at J100, J110, J150, and J170 on the OUT10G board(s).

You need a digital multimeter to check the proper connection.

Perform the following steps:

1. Set the digital multimeter to the Ω mode.
2. Attach the red test lead to the transmission line near J100 on the OUT10G board. See Figure 4-17.
3. Attach the black test lead to the connector housing at J100 on the OUT10G board. See Figure 4-17.
4. Check that the digital multimeter reading falls within the range of 30 Ω to 70 Ω .
5. Repeat steps 2 through 4 for J110, J150, and J170.
6. If your instrument has two OUT10G boards, repeat steps 2 through 5 for the other board.

Troubleshooting



WARNING. Before performing this or any other procedure in this manual, read the General Safety Summary and Service Safety Summary found at the beginning of this manual.

To prevent possible injury to service personnel or damage to electrical components, please read Preventing ESD on page 4-1.

This section contains information and procedures designed to help you isolate faults to a module.

This section requires that service personnel have the appropriate skills to work on this instrument, including PC troubleshooting and Microsoft Windows operating system skills. Details of PC and Windows operation and service are not in this manual.

For assistance, contact your local Tektronix Service Center.

Equipment Required

You will need a digital multi-meter to check power supply voltages, as described on page 4-42.

Fault Isolation Procedure

Follow the primary troubleshooting tree in Figure 4-18 and Figure 4-19 for fault isolation.

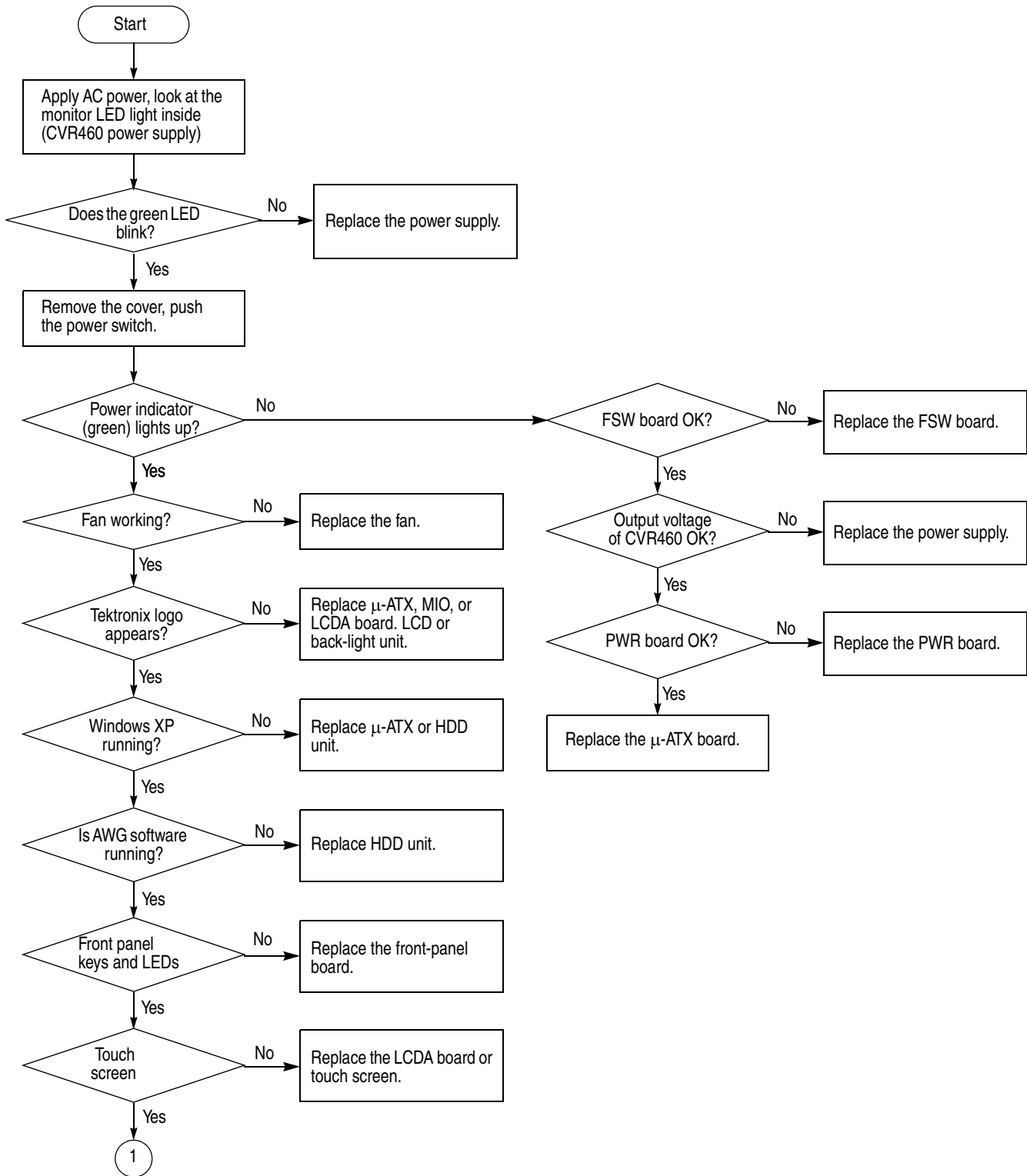

Figure 4-18: Primary troubleshooting tree (1)

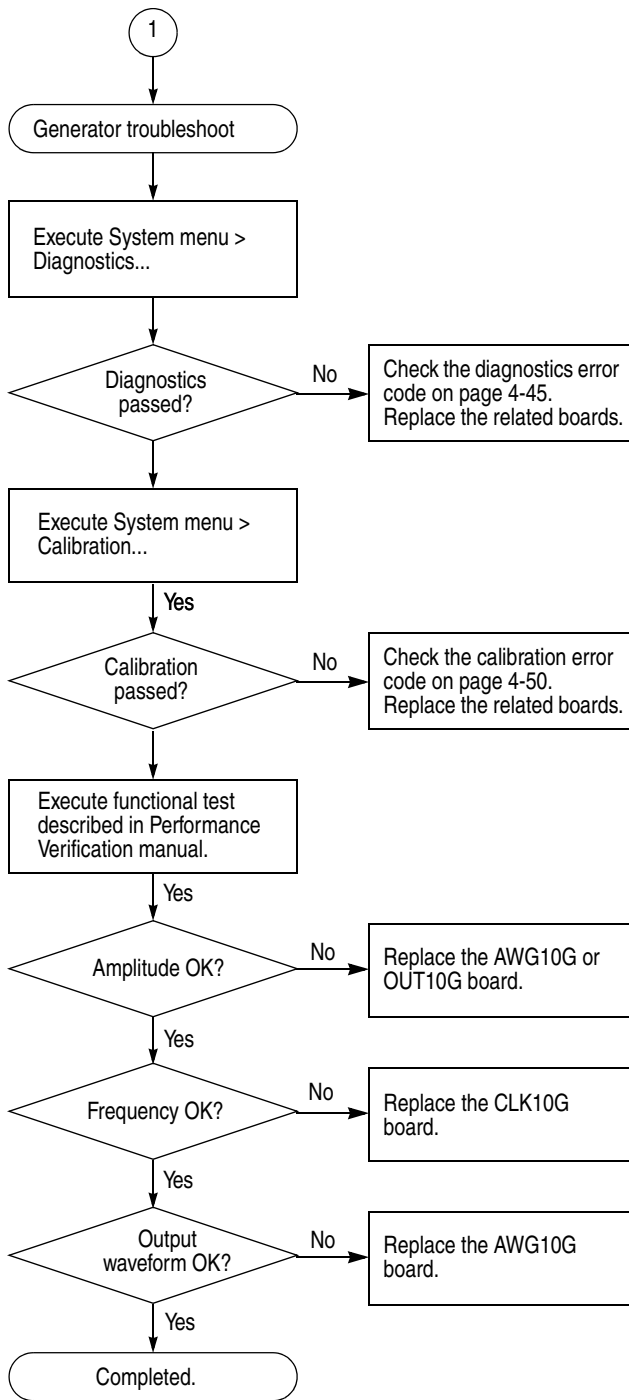

Figure 4-19: Primary troubleshooting tree (2)

Checking the Power Supply Voltages

To check the power supply voltages, power on the instrument and connect the (-) lead of a multi-meter to chassis ground.

To measure the output voltages of the power supply, check the voltages at J104 on the PWR board with the multi-meter and compare each reading to the values listed in Table 4-4. If the voltages are within the allowance, your power supply is functional.

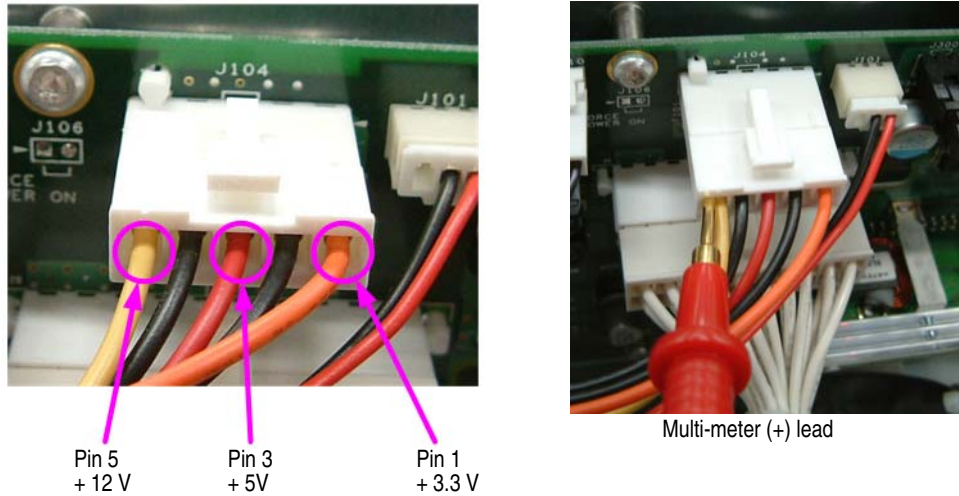

Figure 4-20: PWR board test points

Table 4-4: Power supply voltages

PWR board (J104)	Voltage	Allowance
Pin1	+3.3 V	+3.1 V to +3.5 V
Pin 3	+5 V	+4.7 V to 5.3 V
Pin 5	+12 V	+11.4 V to +12.6 V

Checking the PWR Board Voltages

To measure the output voltages of the PWR board, check the voltages at J2000 on the AWG10G board with the multi-meter and compare each reading to the values listed in Table 4-5. If the voltages are within the allowance, your PWR board is functional.

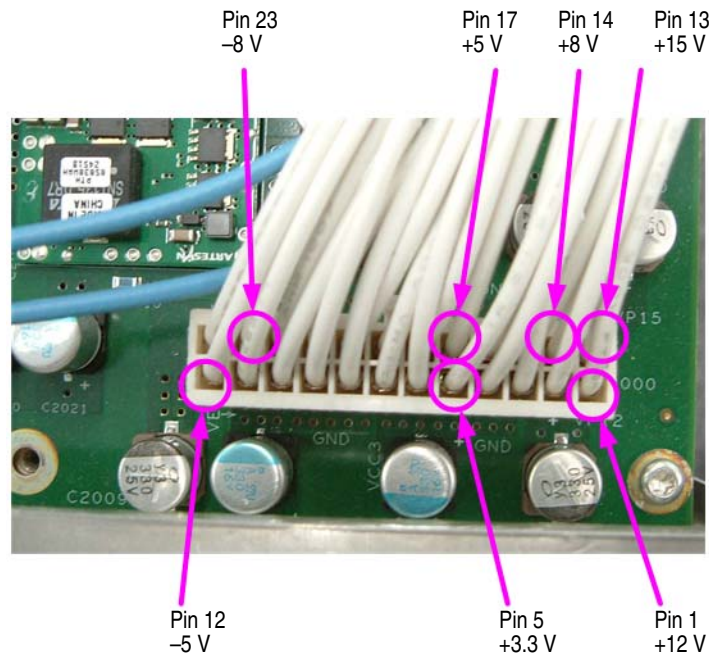

Figure 4-21: AWG10G board test points

Table 4-5: PWR board voltages

AWG10G board (J2000)	Voltage	Allowance
Pin 1	+12 V	+11.4 V to +12.6 V
Pin 5	+3.3 V	+3.1 V to +3.5 V
Pin 12	-5 V	-4.7 to -5.4 V
Pin 13	+15 V	+14.2 V to +15.8 V
Pin 14	+8 V	+7.6 V to +8.4 V
Pin 17	+5 V	+4.7 V to +5.3 V
Pin 23	-8 V	-7.6 to -8.4 V

Instrument Diagnostics

The primary diagnostics for the instrument are accessible through the AWG application software. The Instrument diagnostics check the basic functionality of analog and marker output at every power on. The Instrument Diagnostics run after Windows has booted up and run its own set of system checks. If any failures occur at power on, a pop-up message indicates that a failure has occurred and provides an error code. Table 4-6 lists diagnostics error codes, Table 4-7 lists calibration error codes, and Table 4-8 lists hardware error codes.

The power-on tests ensure that the hardware is installed and can be accessed by the software. The tests provide limited diagnostic information, and provide no performance information.

To run the instrument Diagnostics manually, do these steps:

1. Turn off all other applications.
2. From the menu bar, select **System** and then select **Diagnostics...**; the Diagnostics dialog box appears (see Figure 4-22).

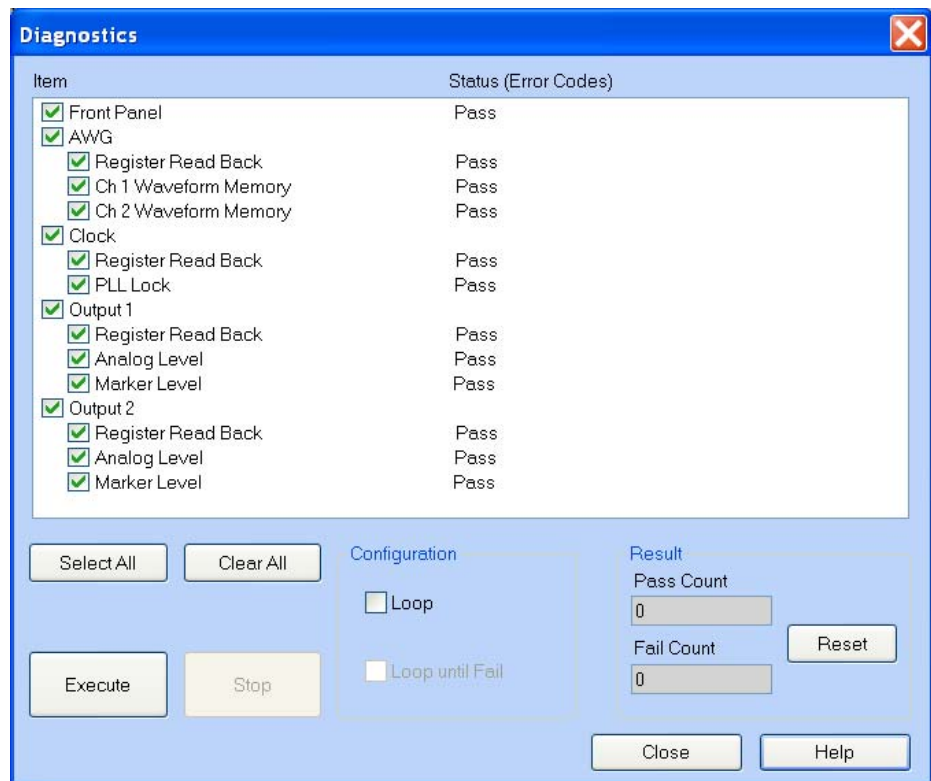

Figure 4-22: Diagnostics dialog box

Table 4-6: Diagnostics error

Error code	Error log message	Possible defect on board	Note
12000000	HwDiagAwgRegister AwgController address_0x21 register diag. Fail expected data=xxxx actual data=xxxx	AWG10G	AWG10G: U1000
12000001	HwDiagAwgRegister AwgController address_0x23 register diag. Fail expected data=xxxx actual data=xxxx	AWG10G	AWG10G: U1000
12000002	HwDiagAwgRegister AwgController address_0x30 register diag. Fail expected data=xxxx actual data=xxxx	AWG10G	AWG10G: U1000
12000003	HwDiagAwgRegister AwgController address_0x40 register diag. Fail expected data=xxxx actual data=xxxx	AWG10G	AWG10G: U1000
12000004	HwDiagAwgRegister AwgController address_0x41 register diag. Fail expected data=xxxx actual data=xxxx	AWG10G	AWG10G: U1000
12000005	HwDiagAwgRegister AwgController address_0x42 register diag. Fail expected data=xxxx actual data=xxxx	AWG10G	AWG10G: U1000
12000006	HwDiagAwgRegister AwgController address_0x50 register diag. Fail expected data=xxxx actual data=xxxx	AWG10G	AWG10G: U1000
12000007	HwDiagAwgRegister Ch1 MemoryController-N Communication Fail expected data=xxxx actual data=xxxx -N:PLD no	AWG10G: U1000	N=0 -> U400PA N=1 -> U400QA N=2 -> U400RA N=3 -> U400SA N=4 -> U400TA
12000008	HwDiagAwgRegister Ch2 MemoryController-N Communication Fail expected data=xxxx actual data=xxxx -N:PLD no	AWG10G: U1000	N=0 -> U400PB N=1 -> U400QB N=2 -> U400RB N=3 -> U400SB N=4 -> U400TB
12000009	HwDiagAwgRegister Ch1 TEK0015-TNO address_REG register diag. Fail expected data=xxxx actual data=xxxx TNO: TEK0015 number REG: Register number	AWG10G: U1000	TNO=0 -> U300PA TNO=1 -> U300QA TNO=2 -> U300RA TNO=3 -> U300SA TNO=4 -> U300TA
12000010	HwDiagAwgRegister Ch2TEK0015-TNO address_REG register diag. Fail expected data=xxxx actual data=xxxx TNO: TEK0015 number REG: Register number	AWG10G: U1000	TNO=0 -> U300PB TNO=1 -> U300QB TNO=2 -> U300RB TNO=3 -> U300SB TNO=4 -> U300TB
12000011	HwDiagAwgRegister Ch1 HFD205 address_REG register diag. Fail expected data=xxxx actual data=xxxx REG: Register number	AWG10G	AWG10G: U1000, U100A
12000012	HwDiagAwgRegister Ch2 HFD205 address_REG register diag. Fail expected data=xxxx actual data=xxxx REG: Register number	AWG10G	AWG10G: U1000, U100B
12100000	HwDiagWaveformMemory channel=1, MemoryController-P Data bus Error pinName expected data=xxxxxxx actual data=xxxxxxx P: PLD number pinName:RAM pin name	AWG10G	P=0 -> U400PA,U500PA, U510PA P=1 -> U400QA,U500QA, U510QA P=2 -> U400RA,U500RA, U510RA P=3 -> U400SA,U500SA, U510SA P=4 -> U400TA,U500TA, U510TA

Table 4-6: Diagnostics error (cont.)

Error code	Error log message	Possible defect on board	Note
121000001	HwDiagWaveformMemory channel=1, MemoryController-P Address Bus Error Address=0xXXXXXXXX pinName expected data=xxxxxxx actual data=xxxxxxx P: PLD number pinName:RAM pin name	AWG10G	P=0 -> U400PA, U500PA, U510PA P=1 -> U400QA, U500QA, U510QA P=2 -> U400RA, U500RA, U510RA P=3 -> U400SA, U500SA, U510SA P=4 -> U400TA, U500TA, U510TA
121000002	HwDiagWaveformMemory channel1, MemoryController-P Cell HL Error P: PLD number HL: Low/High	AWG10G	P=0 -> U500PA, U510PA P=1 -> U500QA, U510QA P=2 -> U500RA, U510RA P=3 -> U500SA, U510SA P=4 -> U500TA, U510TA
121000003	HwDiagWaveformMemory channel=1, MemoryController-P Invert Bit bus pinName testNo-testCnt Error expected data=xxxxxxx actual data=xxxxxxx P: PLD number pinName:RAM pin name testNo:1st or 2nd testCnt:1st - 8th	AWG10G	P=0 -> U400PA, U500PA, U510PA P=1 -> U400QA, U500QA, U510QA P=2 -> U400RA, U500RA, U510RA P=3 -> U400SA, U500SA, U510SA P=4 -> U400TA, U500TA, U510TA
122000000	HwDiagWaveformMemory channel=2, MemoryController-P Data bus Error pinName expected data=xxxxxxx actual data=xxxxxxx P: PLD number pinName:RAM pin name	AWG10G	P=0 -> U400PB, U500PB, U510PB P=1 -> U400QB, U500QB, U510QB P=2 -> U400RB, U500RB, U510RB P=3 -> U400SB, U500SB, U510SB P=4 -> U400TB, U500TB, U510TB
122000001	HwDiagWaveformMemory channel=2, MemoryController-P Address Bus Error Address=0xXXXXXXXX pinName expected data=xxxxxxx actual data=xxxxxxx P: PLD number pinName:RAM pin name	AWG10G	P=0 -> U400PB, U500PB, U510PB P=1 -> U400QB, U500QB, U510QB P=2 -> U400RB, U500RB, U510RB P=3 -> U400SB, U500SB, U510SB P=4 -> U400TB, U500TB, U510TB
122000002	HwDiagWaveformMemory channel2, MemoryController-P Cell HL Error P: PLD number HL: Low/High	AWG10G	P=0 -> U500PB, U510PB P=1 -> U500QB, U510QB P=2 -> U500RB, U510RB P=3 -> U500SB, U510SB P=4 -> U500TB, U510TB
122000003	HwDiagWaveformMemory channel=2, MemoryController-P Invert Bit bus pinName testNo-testCnt Error expected data=xxxxxxx actual data=xxxxxxx P: PLD number pinName:RAM pin name testNo:1st or 2nd testCnt:1st - 8th	AWG10G	P=0 -> U400PB, U500PB, U510PB P=1 -> U400QB, U500QB, U510QB P=2 -> U400RB, U500RB, U510RB P=3 -> U400SB, U500SB, U510SB P=4 -> U400TB, U500TB, U510TB
130000000	HwDiagClockRegister PLL_MUX_HIGH=0	AWG10G, CLK10G	AWG10G: U1000 CLK10G: U3200
130000001	HwDiagClockRegister PLL_MUX_LOW=1	AWG10G, CLK10G	AWG10G: U1000 CLK10G: U3200
131000000	HwDiagClockPll 7.5GHz YIG tuning error	AWG10G, CLK10G	AWG10G: U1000, U1040 CLK10G: U3200,U3250,Y3100,Y3280
131000001	HwDiagClockPll 7.5GHz PLL Unlocked	AWG10G, CLK10G	AWG10G: U1000, U1040 CLK10G: U3200,U3250,Y3100,Y3280

Table 4-6: Diagnostics error (cont.)

Error code	Error log message	Possible defect on board	Note
131000002	HwDiagClockPll 1GHz PLL Locked	AWG10G, CLK10G	AWG10G: U1000 CLK10G: U3200
131000003	HwDiagClockPll 4.9GHz YIG tuning error	AWG10G, CLK10G	AWG10G: U1000, U1040 CLK10G: U3200,U3250,Y3100,Y3280
131000004	HwDiagClockPll 4.9GHz PLL Unlocked	AWG10G, CLK10G	AWG10G: U1000, U1040 CLK10G: U3200,U3250,Y3100,Y3280
131000005	HwDiagClockPll 10.1GHz YIG tuning error	AWG10G, CLK10G	AWG10G: U1000, U1040 CLK10G: U3200,U3250,Y3100,Y3280
131000006	HwDiagClockPll 10.1GHz PLL Unlocked	AWG10G, CLK10G	AWG10G: U1000, U1040 CLK10G: U3200,U3250,Y3100,Y3280
140000000	The error occurred in the EEPROM read. 1st= <i>FST</i> 2nd= <i>SND</i> <i>FST: the data that is received from EEPROM at the first read check</i> <i>SND: the data that is received from EEPROM at the second read check, which is implemented after writing 0x55 to EEPROM</i>	OUT10G	OUT10G-CH1: U500, U550
140000001	<i>Message varies depending on the situation.</i>	OUT10G	OUT10G-CH1: U500, U550
1410P0001	Analog Level Diag CH1 positive (negative) 5db attenuator failed. expected 0.56234, actual xxxxx	OUT10G	OUT10G: K610, K710
1410P0002	Analog Level Diag CH1 positive (negative) 5db attenuator failed. expected 0.56234, actual xxxxx	OUT10G	OUT10G: K610, K710
1410P0003	Analog Level Diag CH1 positive (negative) 10db attenuator failed. expected 0.31627, actual xxxxx	OUT10G	OUT10G: K620, K720
1410P0004	Analog Level Diag CH1 positive (negative) 20db attenuator failed. expected 0.100000, actual xxxxx	OUT10G	OUT10G: K630, K730
1410P0005	Analog Level Diag CH1 positive (negative) 50mhz filter failed. expected 0.992, actual xxxxx	OUT10G	OUT10G: K660, K760
1410P0006	Analog Level Diag CH1 positive (negative) 200mhz filter failed. expected 0.998, actual xxxxx	OUT10G	OUT10G: K670, K770
1410P0007	Analog Level Diag CH1 positive (negative) amplitude cal failed. expected 2.07, actual xxxxx	OUT10G	OUT10G: U800
1410P0008	Analog Level Diag CH1 positive (negative) hfd dac reference failed.	AWG10G	AWG10G: U100A, U150A
1410P0009	Analog Level Diag CH1 positive (negative) output offset failed. expected 0.50V(0.0V), actual xxxxx	AWG10G	OUT10G: U900, U910, U920
141000010	Analog Level Diag CH1 internal offset 8bit failed. expected 0.0mV, actual xxxxxmV	AWG10G	AWG10G: U100A, U150A
141000011	Analog Level Diag CH1 internal offset 10bit failed. expected 0.0mV, actual xxxxxmV	AWG10G	AWG10G: U100A, U150A
141000012	Analog Level Diag CH1 can't find 8bit outamp offset cross point. expected 0.0mV, actual pos: xxxxxmV, neg: xxxxxmV	AWG10G	AWG10G: U100A, U150A
141000013	Analog Level Diag CH1 can't find 10bit outamp offset cross point. expected 0.0mV, actual pos: xxxxxmV, neg: xxxxxmV	AWG10G	AWG10G: U100A, U150A
141000015	Analog Level Diag CH1 5db attenuator gain balance failed.	OUT10G	OUT10G: K610, K710
141000016	Analog Level Diag CH1 5db attenuator gain balance failed.	OUT10G	OUT10G: K610, K710

Table 4-6: Diagnostics error (cont.)

Error code	Error log message	Possible defect on board	Note
141000017	Analog Level Diag CH1 10db attenuator gain balance failed.	OUT10G	OUT10G: K620, K720
141000018	Analog Level Diag CH1 20db attenuator gain balance failed.	OUT10G	OUT10G: K630, K730
141000019	Analog Level Diag CH1 filter 50mhz gain balance failed.	OUT10G	OUT10G: K660, K760
141000020	Analog Level Diag CH1 filter 200mhz gain balance failed.	OUT10G	OUT10G: K670, K770
141000021	Analog Level Diag CH1 amp gain balance failed.	OUT10G	OUT10G: U800
1420M0001	Marker Level Diag CH1 MARKER M offset failed.	OUT10G	U120,U170,U230,U240,U330,U340
1420M0002	Marker Level Diag CH1 MARKER M positive offset failed.	OUT10G	U120,U170,U230,U240,U330,U340
1420M0003	Marker Level Diag CH1 MARKER M negative offset failed.	OUT10G	U120,U170,U230,U240,U330,U340
1420M0004	Marker Level Diag CH1 MARKER M amplitude failed.	OUT10G	U120,U170,U230,U240,U330,U340
1420M0005	Marker Level Diag CH1 MARKER M amplitude correction failed.	OUT10G	U120,U170,U230,U240,U330,U340
150000000	The error occurred in the EEPROM read. 1st= <i>FST</i> 2nd= <i>SND</i> <i>FST: the data that is received from EEPROM at the first read check</i> <i>SND: the data that is received from EEPROM at the second read check, which is implemented after writing 0x55 to EEPROM</i>	OUT10G	OUT10G-CH2: U500, U550
150000001	<i>Message varies depending on the situation.</i>	OUT10G	OUT10G-CH1: U500, U550
1510P0001	Analog Level Diag CH2 positive (negative) 5db attenuator failed. expected 0.56234, actual xxxxx	OUT10G	OUT10G: K610, K710
1510P0002	Analog Level Diag CH2 positive (negative) 5db attenuator failed. expected 0.56234, actual xxxxx	OUT10G	OUT10G: K610, K710
1510P0003	Analog Level Diag CH2 positive (negative) 10db attenuator failed. expected 0.31627, actual xxxxx	OUT10G	OUT10G: K620, K720
1510P0004	Analog Level Diag CH2 positive (negative) 20db attenuator failed. expected 0.100000, actual xxxxx	OUT10G	OUT10G: K630, K730
1510P0005	Analog Level Diag CH2 positive (negative) 50mhz filter failed. expected 0.992, actual xxxxx	OUT10G	OUT10G: K660, K760
1510P0006	Analog Level Diag CH2 positive (negative) 200mhz filter failed. expected 0.998, actual xxxxx	OUT10G	OUT10G: K670, K770
1510P0007	Analog Level Diag CH2 positive (negative) amplitude cal failed. expected 2.07, actual xxxxx	OUT10G	OUT10G: U800
1510P0008	Analog Level Diag CH2 positive (negative) hfd dac reference failed.	AWG10G	AWG10G: U100B, U150B
1510P0009	Analog Level Diag CH2 positive (negative) output offset failed. expected 0.50V(0.0V), actual xxxxx	OUT10G	OUT10G: U900, U910, U920
151000010	Analog Level Diag CH2 internal offset 8bit failed. expected 0.0mV, actual xxxxxmV	AWG10G	AWG10G: U100B, U150B
151000011	Analog Level Diag CH2 internal offset 10bit failed. expected 0.0mV, actual xxxxxmV	AWG10G	AWG10G: U100B, U150B
151000012	Analog Level Diag CH2 can't find 8bit outamp offset cross point. expected 0.0mV, actual pos: xxxxxmV, neg: xxxxxmV	AWG10G	AWG10G: U100B, U150B
151000013	Analog Level Diag CH2 can't find 10bit outamp offset cross point. expected 0.0mV, actual pos: xxxxxmV, neg: xxxxxmV	AWG10G	AWG10G: U100B, U150B

Table 4-6: Diagnostics error (cont.)

Error code	Error log message	Possible defect on board	Note
151000015	Analog Level Diag CH2 5db attenuator gain balance failed.	OUT10G	OUT10G: K610, K710
151000016	Analog Level Diag CH2 5db attenuator gain balance failed.	OUT10G	OUT10G: K610, K710
151000017	Analog Level Diag CH2 10db attenuator gain balance failed.	OUT10G	OUT10G: K620, K720
151000018	Analog Level Diag CH2 20db attenuator gain balance failed.	OUT10G	OUT10G: K630, K730
151000019	Analog Level Diag CH2 filter 50mhz gain balance failed.	OUT10G	OUT10G: K660, K760
151000020	Analog Level Diag CH2 filter 200mhz gain balance failed.	OUT10G	OUT10G: K670, K770
151000021	Analog Level Diag CH2 amp gain balance failed.	OUT10G	OUT10G: U800
1520M0001	Marker Level Diag CH2 MARKER M offset failed.	OUT10G	U120,U170,U230,U240,U330,U340
1520M0002	Marker Level Diag CH2 MARKER M positive offset failed.	OUT10G	U120,U170,U230,U240,U330,U340
1520M0003	Marker Level Diag CH2 MARKER M negative offset failed.	OUT10G	U120,U170,U230,U240,U330,U340
1520M0004	Marker Level Diag CH2 MARKER M amplitude failed.	OUT10G	U120,U170,U230,U240,U330,U340
1520M0005	Marker Level Diag CH2 MARKER M amplitude correction failed.	OUT10G	U120,U170,U230,U240,U330,U340
190000000	TekLink receive error Send= <i>TR</i> Recv= <i>RV</i> <i>TR:Transmission data</i> <i>RV:Receive data</i>	MIO	MIO: U300

Calibration Error

To run the instrument calibration, do these steps:

1. Turn off all other applications.
2. From the menu bar, select **System** and then select **Calibration...**; the Calibration dialog box appears.

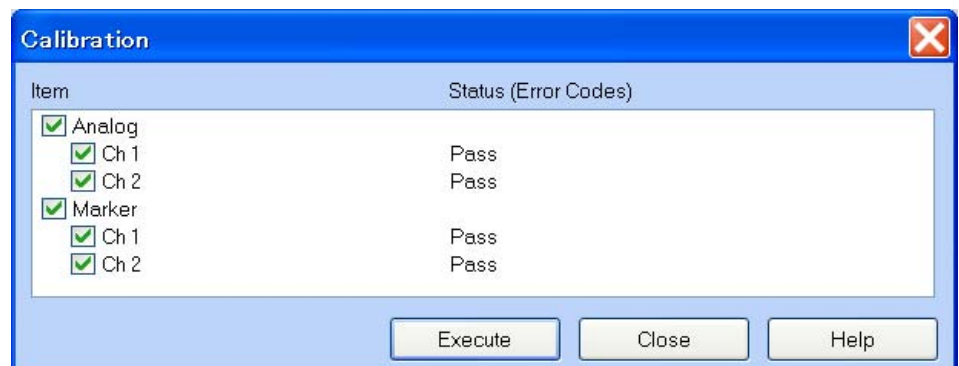

Figure 4-23: Calibration dialog box

Table 4-7: Calibration error

Error code	Error log message	Possible defect on board	Note
200XP0001	Analog Level Calibration CHX positive (negative) 5db attenuator failed. expected 0.56234, actual xxxxx	OUT10G	OUT10G: K610, K710
200XP0002	Analog Level Calibration CHX positive (negative) 5db attenuator failed. expected 0.56234, actual xxxxx	OUT10G	OUT10G: K610, K710
200XP0003	Analog Level Calibration CHX positive (negative) 10db attenuator failed. expected 0.31627, actual xxxxx	OUT10G	OUT10G: K620, K720
200XP0004	Analog Level Calibration CHX positive (negative) 20db attenuator failed. expected 0.100000, actual xxxxx	OUT10G	OUT10G: K630, K730
200XP0005	Analog Level Calibration CHX positive (negative) 50mhz filter failed. expected 0.992, actual xxxxx	OUT10G	OUT10G: K660, K760
200XP0006	Analog Level Calibration CHX positive (negative) 200mhz filter failed. expected 0.998, actual xxxxx	OUT10G	OUT10G: K670, K770
200XP0007	Analog Level Calibration CHX positive (negative) amplitude cal failed. expected 2.07, actual xxxxx	OUT10G	OUT10G: U800
200XP0008	Analog Level Calibration CHX positive (negative) hfd dac reference failed.	OUT10G	AWG10G: U100A/B, U150A/B
200XP0009	Analog Level Calibration CHX positive (negative) output offset failed. expected 0.50V(0.0V), actual xxxxx	OUT10G	OUT10G: U900, U910, U920
200XP0010	Analog Level Calibration CHX internal offset 8bit failed. expected 0.0mV, actual xxxxxmV	OUT10G	AWG10G: U100A/B, U150A/B
200XP0011	Analog Level Calibration CHX internal offset 10bit failed. expected 0.0mV, actual xxxxxmV	OUT10G	AWG10G: U100A/B, U150A/B
200XP0012	Analog Level Calibration CHX can't find 8bit outamp offset cross point. expected 0.0mV, actual pos: xxxxxmV, neg: xxxxxmV	AWG10G	AWG10G: U100A/B, U150A/B
200XP0013	Analog Level Calibration CHX can't find 10bit outamp offset cross point. expected 0.0mV, actual pos: xxxxxmV, neg: xxxxxmV	AWG10G	AWG10G: U100A/B, U150A/B
200XP0015	Analog Level Calibration CHX 5db attenuator gain balance failed.		
200XP0016	Analog Level Calibration CHX 5db attenuator gain balance failed.		
200XP0017	Analog Level Calibration CHX 10db attenuator gain balance failed.		
200XP0018	Analog Level Calibration CHX 20db attenuator gain balance failed.		
200XP0019	Analog Level Calibration CHX filter 50mhz gain balance failed.		
200XP0020	Analog Level Calibration CHX filter 200mhz gain balance failed.		
200XP0021	Analog Level Calibration CHX amp gain balance failed.		
210XM0001	Marker Level Calibration CHX MARKER M offset failed.	OUT10G	OUT10G: U120, U170, U230, U240, U330, U340
210XM0002	Marker Level Calibration CHX MARKER M positive offset failed.	OUT10G	OUT10G: U120, U170, U230, U240, U330, U340
210XM0003	Marker Level Calibration CHX MARKER M negative offset failed.	OUT10G	OUT10G: U120, U170, U230, 240, U330, U340
210XM0004	Marker Level Calibration CHX MARKER M amplitude failed.	OUT10G	OUT10G: U120, U170, U230, U240, U330, U340
210XM0005	Marker Level Calibration CHX MARKER M amplitude correction failed.	OUT10G	OUT10G: U120, U170, U230, U240, U330, U340

Table 4-7: Calibration error (cont.)

Error code	Error log message	Possible defect on board	Note
220000000	HwExecMarkerDelayCal (channel=1) A maximum and a minimum difference are smaller than 80ps at coarse=15	AWG10G	AWG10G: U1000, U100A
220000001	HwExecMarkerDelayCal (channel=2) A maximum and a minimum difference are smaller than 80ps at coarse=15	AWG10G	AWG10G: U1000, U100B
220000002	HwExecMarkerDelayCal (channel=1) Frequency measurement cannot be performed.	AWG10G	AWG10G: U1000, U100A
220000003	HwExecMarkerDelayCal (channel=2) Frequency measurement cannot be performed.	AWG10G	AWG10G: U1000, U100B
220000004	HwExecMarkerDelayCal (channel=1) A maximum value is smaller than 300ps at coarse=15.	AWG10G	AWG10G: U100A
220000005	HwExecMarkerDelayCal (channel=2) A maximum value is smaller than 300ps at coarse=15.	AWG10G	AWG10G: U100B
220000006	HwExecMarkerDelayCal (channel=1) There are not data in ascending order coarse=%d	AWG10G	AWG10G: U1000, U100A, U195A
220000007	HwExecMarkerDelayCal (channel=2) There are not data in ascending order coarse=%d	AWG10G	AWG10G: U1000, U100B, U195B
230000000	N/A	AWG10G	AWG10G: U100A/B, U4000
240000000	N/A	AWG10G	AWG10G: U100A/B, U4000
250000000	The Cal value is not found.(10G-Write)	AWG10G	AWG10G: U1000, U400
250000001	The Cal value is not found.(8G-Write)	AWG10G	AWG10G: U1000, U400
250000002	The Cal value is not found.(10G-Read)	AWG10G	AWG10G: U1000, U400
250000004	The Cal value is not found.(Waveform RAM Write Timing CH1)	AWG10G	AWG10G: U400A, U500A, U510A
250000005	The Cal value is not found.(Waveform RAM Write Timing CH2)	AWG10G	AWG10G: U400B, U500B, U510B
250000006	Invalid NG Areas.(10G-Write)	AWG10G	U400PA
250000007	Invalid NG Areas.(8G-Write)	AWG10G	U400PA
260000200	Waveform write error.	AWG10G	AWG10G: U400, U500, U510
260000001	The Cal value is not found. (ch1_ram_address_timing_1@10GHz)	AWG10G	AWG10G: U400A, U500A, U510A
260000002	The Cal value is not found. (ch2_ram_address_timing_1@10GHz)	AWG10G	AWG10G: U400B, U500B, U510B
260000003	The Cal value is not found. (ch1_ram_address_timing_1@8GHz)	AWG10G	AWG10G: U400A, U500A, U510A
260000004	The Cal value is not found. (ch2_ram_address_timing_1@8GHz)	AWG10G	AWG10G: U400B, U500B, U510B
260000005	The Cal value is not found. (ch1_ram_data_timing_1@10GHz)	AWG10G	AWG10G: U400A, U500A, U510A
260000006	The Cal value is not found. (ch2_ram_data_timing_1@10GHz)	AWG10G	AWG10G: U400B, U500B, U510B
260000007	The Cal value is not found. (ch1_ram_data_timing_2@8GHz)	AWG10G	AWG10G: U400A, U500A, U510A
260000008	The Cal value is not found. (ch2_ram_data_timing_2@8GHz)	AWG10G	AWG10G: U400B, U500B, U510B
260000101	The difference of ch1_ram_address_timing_1 and ch2_ram_address_timing_1 is larger than 96.(@10GHz)	AWG10G	AWG10G: U400, U500, U510
260000103	The difference of ch1_ram_address_timing_2 and ch2_ram_address_timing_2 is larger than 96.(@8GHz)	AWG10G	AWG10G: U400, U500, U510
260001001	Invalid NG Areas.(ch1_ram_address_timing@10GHz)	AWG10G	AWG10G: U400xA
260001002	Invalid NG Areas.(ch2_ram_address_timing@10GHz)	AWG10G	AWG10G: U400xB
260001003	Invalid NG Areas.(ch1_ram_address_timing@8GHz)	AWG10G	AWG10G: U400xA
260001004	Invalid NG Areas.(ch2_ram_address_timing@8GHz)	AWG10G	AWG10G: U400xB

Table 4-7: Calibration error (cont.)

Error code	Error log message	Possible defect on board	Note
260000105	The difference of ch1_ram_data_timing_1 and ch2_ram_data_timing_1 is larger than 96.(@10GHz)	AWG10G	AWG10G: U400, U500, U510
260000107	The difference of ch1_ram_data_timing_2 and ch2_ram_data_timing_2 is larger than 96.(@8GHz)	AWG10G	AWG10G: U400, U500, U510
260000108	The difference of ch1_ram_data_timing_1 - ch1_ram_data_timing_2 is larger than 96.	AWG10G	AWG10G: U400A, U500A, U510A
260000109	The difference of ch2_ram_data_timing_1 - ch2_ram_data_timing_2 is larger than 96.	AWG10G	AWG10G: U400B, U500B, U510B
260000011	The Cal value is not found.(ch1_pld_timing_1@10GHz)	AWG10G	AWG10G: U400A
260000012	The Cal value is not found.(ch2_pld_timing_1@10GHz)	AWG10G	AWG10G: U400B
260000013	The Cal value is not found.(ch1_pld_timing_2@8GHz)	AWG10G	AWG10G: U400A
260000014	The Cal value is not found.(ch2_pld_timing_2@8GHz)	AWG10G	AWG10G: U400B
260000015	The Cal value is not found.(ch1_pld_timing_3@10GHz)	AWG10G	AWG10G: U400A
260000016	The Cal value is not found.(ch2_pld_timing_3@10GHz)	AWG10G	AWG10G: U400B
260000017	Temperature changed 5 degrees or more.(@PLD Timing Cal.)		
260000111	The difference of ch1_pld_timing_1 and ch2_pld_timing_1 is larger than 48.(@10GHz)	AWG10G	AWG10G: U400
260000113	The difference of ch1_pld_timing_2 and ch2_pld_timing_2 is larger than 48.(@8GHz)	AWG10G	AWG10G: U400
260000115	The difference of ch1_pld_timing_3 and ch2_pld_timing_3 is larger than 48.(@10GHz)	AWG10G	AWG10G: U400
260001005	Invalid NG Areas.(ch1_pld_timing@10GHz)	AWG10G	AWG10G: U400xA
260001006	Invalid NG Areas.(ch2_pld_timing@10GHz)	AWG10G	AWG10G: U400xB
260001007	Invalid NG Areas.(ch1_pld_timing@8GHz)	AWG10G	AWG10G: U400xA
260001008	Invalid NG Areas.(ch2_pld_timing@8GHz)	AWG10G	AWG10G: U400xB
260000021	The Cal value is not found.(tek15_ch1_timing_1)	AWG10G	AWG10G: U300A
260000022	The Cal value is not found.(tek15_ch2_timing_1)	AWG10G	AWG10G: U300B
260000023	The Cal value is not found.(tek15_ch1_timing_2)	AWG10G	AWG10G: U300A
260000024	The Cal value is not found.(tek15_ch2_timing_2)	AWG10G	AWG10G: U300B
260000025	A coefficient is not also 5 or 6.(tek15_ch1_k)	AWG10G	AWG10G: U300A
260000026	A coefficient is not also 5 or 6.(tek15_ch2_k)	AWG10G	AWG10G: U300B
260000027	The Cal value is not found.(tek15_ch1_ng_f)	AWG10G	AWG10G: U300A
260000028	The Cal value is not found.(tek15_ch2_ng_f)	AWG10G	AWG10G: U300B
260000029	Temperature changed 5 degrees or more.(@Magic Cal.)		
260000121	The difference of tek15_ch1_timing_1 and tek15_ch2_timing_1 is larger than 150ps.	AWG10G	AWG10G: U300
260000123	The difference of tek15_ch1_timing_2 and tek15_ch2_timing_2 is larger than 150ps.	AWG10G	AWG10G: U300
260000125	tek15_ch1_k and tek15_ch2_k are not equal.	AWG10G	AWG10G: U300
260001009	Invalid NG Areas.(ch1@Magic Cal.)	AWG10G	AWG10G: U300xA
260001010	Invalid NG Areas.(ch2@Magic Cal.)	AWG10G	AWG10G: U300xB
270000000	HwExecYigCal PLL read error	AWG10G	AWG10G: U1000, U1040
270000001	HwExecYigCal PLL 5GHz offset under 2048 vtune=xxxx	CLK10G	CLK10G: U3200, U3250, Y3280

Table 4-7: Calibration error (cont.)

Error code	Error log message	Possible defect on board	Note
270000002	HwExecYigCal PLL 5GHz offset underflow vtune=xxxx	CLK10G	CLK10G: U3200, U3250, Y3280
270000003	HwExecYigCal PLL 5GHz tuning underflow vtune=xxxx	CLK10G	CLK10G: U3200, U3250, Y3280
270000004	HwExecYigCal PLL 5GHz tuning underflow vtune=xxxx	CLK10G	CLK10G: U3200, U3250, Y3280
270000005	HwExecYigCal PLL 10GHz tuning over 4095 vtune=xxxx	CLK10G	CLK10G: U3200, U3250, Y3280
270000006	HwExecYigCal PLL 10GHz tuning overflow vtune=xxxx	CLK10G	CLK10G: U3200, U3250, Y3280
290000000	Marker Level Calibration has not been completed.	N/A	
290000001	Marker cross point calibration result exceeds limit.	OUT10G	OUT10G: U120, U170
290X00000	Marker Level Calibration has not been completed at CHX.	N/A	
290XY0001	Marker cross point calibration result exceeds limit at CHX, MARKER Y.	OUT10G, AWG10G	OUT10G: U120/170, U470/480, J100/110/150/170 AWG10G: J110A/111A/115A/ 116A/110B/111B/115B/116B
290XY0002	Marker cross point calibration couldn't be converged on -1.0V at CHX, MARKER Y.	OUT10G, AWG10G	OUT10G: U120/170, U470/480, J100/110/150/170 AWG10G: J110A/111A/115A/ 116A/110B/111B/115B/116B

Hardware Error

Table 4-8 lists the instrument hardware related errors.

Table 4-8: Hardware error

Error code	Error log message	Possible defect on board	Note
300000000	The system cannot find the device specified.	MIO	MIO: U100, U200, U220, Y230
300000001	The device is not ready.	N/A	
300000002	The AWG register access timeout period has expired.		MIO: U200, U300 AWG10G: U1000 MIO-AWG10G Cable
300000003	The time-out was generated while measuring data.	AWG10G	AWG10G: U1000
300000004	The timer for the trigger has stopped.	AWG10G	AWG10G: U1000
300000005	PLL doesn't lock.	AWG10G, CLK10G	AWG10G: U1000 CLK10G: U3200, U3250, Y3260...
300000006	AwgController DLL doesn't lock.	AWG10G	AWG10G: U1000
300000007	Output board access error Board=No No: Board number (Start with 0)	OUT10G	OUT10G: U500
300000008	Not enough storage is available to process.	N/A	
300000009	Calibration checksum data has an error.	MIO	MIO: U300, U390
300000010	Calibration version unmatched.	MIO	MIO: U300, U390
300000011	YIG tuning has an error.	CLK10G	CLK10G: U3200, U3250, Y3260...

Table 4-8: Hardware error (cont.)

Error code	Error log message	Possible defect on board	Note
30000012	The Ipc busy timeout period has expired.	AWG10G	AWG10G: U1000
30000013	MemoryController DLL doesn't lock.	AWG10G	AWG10G: U1000, U400xx
30000014	MemoryController Dynamic Phase Shift - IPC error.	AWG10G	AWG10G: U1000, U400xx
30000015	MemoryController Dynamic Phase Shift - Waveform RAM error.	AWG10G	AWG10G: U1000, U400xx
30000016	MemoryController Dynamic Phase Shift - System Clock error.	AWG10G	AWG10G: U1000, U400xx
30000017	The Diag busy timeout period has expired.	AWG10G	AWG10G: U1000, U400xx
30000018	MemoryController Dynamic Phase Shift - Mux error.	AWG10G	AWG10G: U1000, U400xx
30000019	AWG10G board Calibration checksum data has an error.	AWG10G	
30000020	AWG10G board Calibration version unmatched.	AWG10G	
300000100	The access of MIO board EEPROM, it failed.	MIO	MIO: U300, U390
300000101	The access of OUTPUT board EEPROM, it failed.	OUT10G	OUT10G: U500, U550
300000102	The relay count is invalid. Board-1	OUT10G	OUT10G: U500, U550
300000103	The relay count is invalid. Board-2	OUT10G	OUT10G: U500, U550
300000104	The access of AWG board EEPROM, it failed.	AWG10G	AWG10G: U1090
300000200	The download (INIT) timeout period has expired.	MIO	MIO: U200,U300
300000201	The download (INIT) timeout period has expired.	MIO	MIO: U200,U300
300000202	The download (DONE) timeout period has expired.	MIO	MIO: U200,U300
300000203	The download timeout period has expired.	MIO	MIO: U200,U300
300000204	The system cannot find the file specified.(PLD140b.Bit)	N/A	
300000205	An attempt was made to load a program with an incorrect format.(PLD131.Bit)	N/A	
300000206	The download(AwgController-INIT) timeout period has expired.	MIO, AWG10G	MIO: U300 AWG10G: U1000 MIO-AWG10G Cable
300000207	The download(AwgController-INIT) timeout period has expired.	MIO, AWG10G	MIO: U300 AWG10G: U1000
300000208	The download(DONE) timeout period has expired.	MIO, AWG10G	MIO: U300 AWG10G: U1000 MIO-AWG10G Cable
300000209	The download timeout period has expired.	MIO, AWG10G	MIO: U300 AWG10G: U1000 MIO-AWG10G Cable
300000210	The system cannot find the file specified.(PLD131.Bit)	N/A	
300000211	An attempt was made to load a program with an incorrect format.(PLD131.Bit)	N/A	
300000212	The download (AwgController-INIT) timeout period has expired.	MIO, AWG10G	MIO: U300 AWG10G: U1000, U400xx
300000213	The download (AwgController-INIT) timeout period has expired.	MIO, AWG10G	MIO: U300 AWG10G: U1000, U400xx
300000214	The download (AwgController-DONE) timeout period has expired.	MIO, AWG10G	MIO: U300 AWG10G: U1000, U400xx
300000215	The download (AwgController) timeout period has expired.	MIO, AWG10G	MIO: U300 AWG10G: U1000, U400xx
300000216	The system cannot find the file specified.(PLD130b.Bit)	N/A	

Table 4-8: Hardware error (cont.)

Error code	Error log message	Possible defect on board	Note
300000217	An attempt was made to load a program with an incorrect format.(PLD130b.Bit)	N/A	
300000218	The DCM timeout period has expired.	MIO	MIO: U300
300000219	The LOCKED timeout period has expired.	MIO	MIO: U300
300000220	A PLD131.bit file is old version.	N/A	
300000221	A PLD130.bit file is old version.	N/A	
310000000	The parameter is incorrect.	N/A	
390000001	The calibration data is invalid. The default value is used.	N/A	
390000002	*** Warning *** It started with Manufacturing mode.	N/A	
390000003	The calibration data is invalid. The default value is used.	N/A	

After Repair

After removal and replacement of a module, you must perform the Adjustment and Performance Verification procedures. You can find the information about these procedures in the following manuals:

- *AWG7000 Series Arbitrary Waveform Generators Service Manual* (Tektronix part number 071-1854-XX)
- *AWG7000 Series Arbitrary Waveform Generators Specifications and Performance Verification* (Tektronix part number 071-1853-XX)

Returning the Instrument for Service

When repacking the instrument for shipment, use the original packaging. If the packaging is unavailable or unfit for use, contact your local Tektronix representative to obtain new packaging.

Seal the shipping carton with an industrial stapler or strapping tape.

Before returning the instrument for service, contact the Service Center to get an RMA (return material authorization) number, and any return or shipping information you may need.

If the instrument is being shipped to a Tektronix Service Center, enclose the following information:

- The RMA number.
- The owner's address.
- Name and phone number of a contact person.
- Type and serial number of the instrument.
- Reason for returning.
- A complete description of the required service.

Mark the address of the Tektronix Service Center and the return address on the shipping carton in two prominent locations. See www.tektronix.com/service to find a Tektronix Service Center near you.



Replaceable Parts

Replaceable Parts

This section contains a list of the replaceable modules for the AWG7000 Series Arbitrary Waveform Generators. Use this list to identify and order replacement parts.

Parts Ordering Information

Replacement parts are available through your local Tektronix field office or representative.

Changes to Tektronix instruments are sometimes made to accommodate improved components as they become available and to give you the benefit of the latest circuit improvements. Therefore, when ordering parts, it is important to include the following information in your order.

- Part number
- Instrument type or model number
- Instrument serial number
- Instrument modification number, if applicable

If you order a part that has been replaced with a different or improved part, your local Tektronix field office or representative will contact you concerning any change in part number.

Part Number Revision Level

Tektronix part numbers contain two digits that show the revision level of the part. For most parts in this manual, you will find the letters XX in place of the revision level number.



When you order parts, Tektronix will provide you with the most current part for your product type, serial number, and modification (if applicable). At the time of your order, Tektronix will determine the part number revision level needed for your product, based on the information you provide.

Module Servicing

Modules can be serviced by selecting one of the following three options. Contact your local Tektronix service center or representative for repair assistance.

Module Exchange. In some cases you may exchange your module for a remanufactured module. These modules cost significantly less than new modules and meet the same factory specifications. For more information about the module exchange program, call 1-800-833-9200. Outside North America, contact a Tektronix sales office or distributor; see the Tektronix Web site (www.tektronix.com) for a list of offices.

Module Repair and Return. You may ship your module to us for repair, after which we will return it to you.

New Modules. You may purchase replacement modules in the same way as other replacement parts.

Using the Replaceable Parts List

This section contains a list of the mechanical and/or electrical components that are replaceable for the AWG7000 Series. Use this list to identify and order replacement parts. The following table describes each column in the parts list.

Parts List Column Descriptions

Column	Column name	Description
1	Figure & Index Number	Items in this section are referenced by component number.
2	Tektronix Part Number	Use this part number when ordering replacement parts from Tektronix.
3 and 4	Serial Number	Column three indicates the serial number at which the part was first effective. Column four indicates the serial number at which the part was discontinued. No entries indicates the part is good for all serial numbers.
5	Qty	This indicates the quantity of parts used.
6	Name & Description	An item name is separated from the description by a colon (:). Because of space limitations, an item name may sometimes appear as incomplete. Use the U.S. Federal Catalog handbook H6-1 for further item name identification.

Abbreviations Abbreviations conform to American National Standard ANSI Y1.1-1972.

Replaceable parts list

Fig. & index number	Tektronix part number	Serial no. effective	Serial no. discont'd	Qty	Name & description
5-1					COSMETICS
-1	335-1588-00			1	MARKER,IDENT; LABEL,IDENTIFICATION;AWG7101,SAFETY CONTROLLED
	335-1589-00			1	MARKER,IDENT; LABEL,IDENTIFICATION;AWG7102,SAFETY CONTROLLED
	335-1590-00			1	MARKER,IDENT; LABEL,IDENTIFICATION;AWG7051,SAFETY CONTROLLED
	335-1591-00			1	MARKER,IDENT; LABEL,IDENTIFICATION;AWG7052,SAFETY CONTROLLED
-2	101-0176-00			1	TRIM,RING;FRONT;SAFETY CONTROLLED
-3	101-0177-00			1	TRIM,ACQUISITION INSERT,HPI.SMA SONNECTOR
-4	101-0174-00			1	TRIM,DVD
-5	260-2837-00			1	KEYPAD; FOR POWER BUTTON TOP,CLEAR,SILICONE RUBBER W/CONDUCTIVE SILICONE RUBBER TIP,SNAP ACTION,TRAVEL 0.045 IN,200 GRAM,HYSTERESIS GT 35%,W TOP COAT
-6	211-1050-00			4	SCREW,MACHINE; 6-32 X 0.312 L,PNH,STL CAD PLT,T15
-7	200-4994-00			1	COVER, COSMETIC, TOP
-8	211-1050-00			4	SCREW,MACHINE; 6-32 X 0.312 L,PNH,STL CAD PLT,T15
-9	355-0298-00			4	STUD.SNAP; 0.570 DIA,0.165 THK,STAINLESS STEEL
-10	211-0732-00			4	SCR,ASSEM WSHR; 6-32 X 0.75,PNH,STL,CD PL,TORX T15
-11	348-1861-00			4	FOOT; REAR, ASSY. W/ CORD WRAP, THERMOPLASTIC,SRY
-12	407-4887-00			1	BRACKET;HANDLE BASE,PC/ABS ALLOY,BAYER BAYBLEND FR-110,TEK BLUE, SAFETY CONTROLLED
-13	212-0232-00			2	SCREW,MACHINE; 8-32 X 1.125L,PNH,STL,BLACK ZINK SPEC #ASTM B633 TYPE II, T-20,TORX DRIVE
-14	367-0528-00			1	HANDLE, CARRYING;DUAL DUROMETER MOLDED, POLYPROPYLENE,VINYL GRIP SECTION,SAFETY CONTROLLED
-15	348-1515-00			2	FEET,CABINET; BLACK,SET OF 4 FEET
-16	200-4995-00			1	COVER, COSMETIC, BOTTOM
-17	211-1050-00			3	SCREW,MACHINE; 6-32 X 0.312 L,PNH,STL CAD PLT,T15
-18	335-1577-00			1	MARKER, IDENTIFICATION, FRONT PANEL, 2 CHANNEL, SAFETY CONTROLLED
	335-1578-00			1	MARKER, IDENTIFICATION, FRONT PANEL, 1 CHANNEL, SAFETY CONTROLLED
-19	335-1581-00			1	MARKER, IDENTIFICATION, SIGNAL INPUT/OUTPUT, SMA, 2 CHANNEL, SAFETY CONTROLLED
	335-1582-00			1	MARKER, IDENTIFICATION, SIGNAL INPUT/OUTPUT, SMA, 2 CHANNEL, INTERLEAVE, SAFETY CONTROLLED (OPTION 06)
	335-1583-00			1	MARKER, IDENTIFICATION, SIGNAL INPUT/OUTPUT, SMA, 1 CHANNEL, SAFETY CONTROLLED
-20	366-0841-00			1	KNOB, CAP; 1.380 DIA, PC/ABS, SILVER GRAY

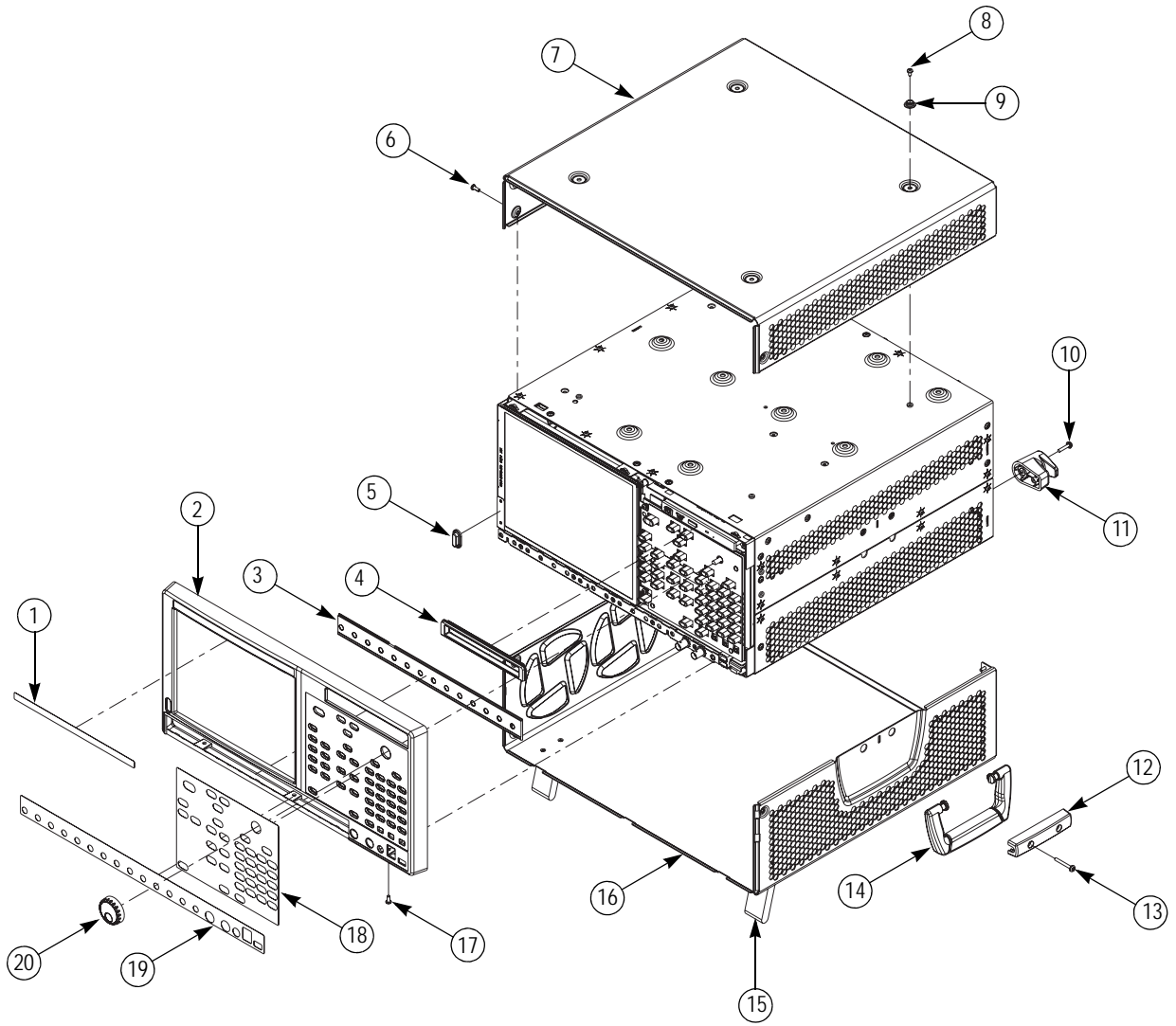

Figure 5-1: Exploded diagram - Cosmetics

Replaceable parts list

Fig. & index number	Tektronix part number	Serial no. effective	Serial no. dis-cont'd	Qty	Name & description
5-2					EMI COVERS
-1	200-4992-00			1	COVER, EMI, TOP
-2	200-4993-00			1	COVER, EMI, BOTTOM
-3	211-1050-00			26	SCREW,MACHINE; 6-32 X 0.312 L,PNH,STL CAD PLT,T15

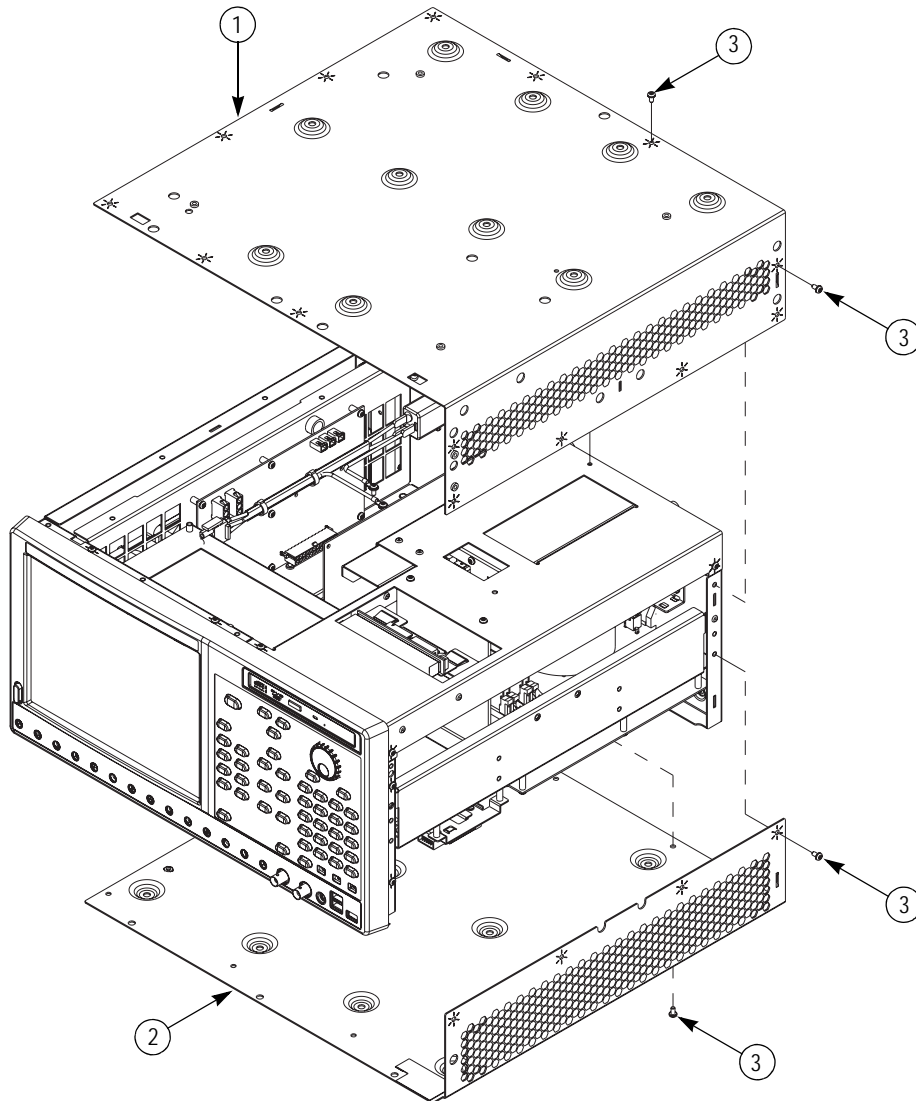

Figure 5-2: Exploded diagram - EMI Covers

Replaceable parts list

Fig. & index number	Tektronix part number	Serial no. effective	Serial no. dis-cont'd	Qty	Name & description
5-3					CHASSIS ASSEMBLY
-1	131-6417-00			1	CONTACT,ELEC; GROUNDING,0.600 L X 0.250 W X 0.220 D,ELECTROLESS NICKEL PLATE
-2	348-0966-00			1	GROMMET,PLASTIC;BLACK,ROUND,0.625 ID
-3	441-2462-00			1	CHASSIS, MAIN; ASSEMBLY

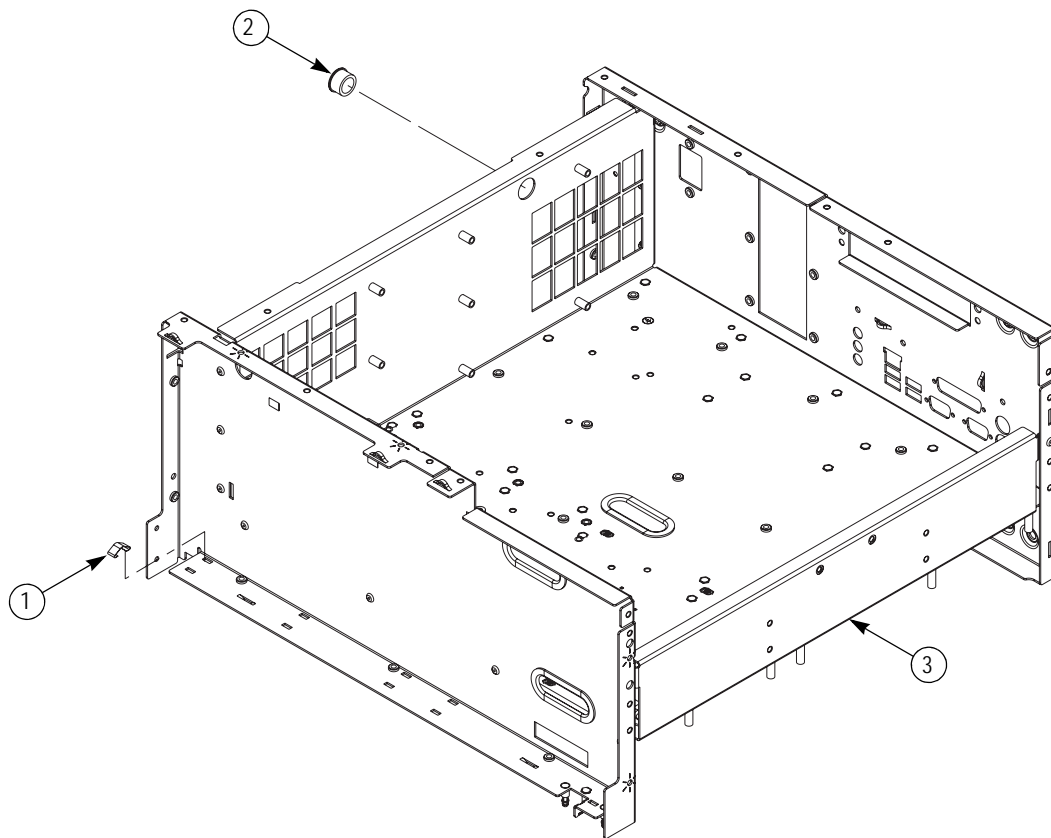

Figure 5-3: Exploded diagram - Chassies assembly

Replaceable parts list

Fig. & index number	Tektronix part number	Serial no. effective	Serial no. dis-cont'd	Qty	Name & description
5-4					FRONT-PANEL ASSEMBLY
-1	065-0762-00			1	TOUCH SCREEN ASSEMBLY
-2	211-1050-00			4	SCREW,MACHINE; 6-32 X 0.312 L,PNH,STL CAD PLT,T15
-3	119-6813-00			1	DISPLAY 10.4 INCH NL10276BC24-13
-4	361-1836-00			2	SPACER,PLATE; LEXAN,TOUCH SCREEN,W/ADHESIVE
-5	407-5173-00			1	BRACKET;DISPLAY
-6	119-6806-00			1	POWER SUPPLY;INVERTER
-7	211-0069-00			2	SCREW,MACHINE; 2-56 X 0.125,PNH,STL CR PL,POZ
-8	174-4794-00			1	CA ASSY; DISPLAY ADAPTER TO INVERTOR,SAFETY CONTROLLED
-9	671-6151-00			1	CIRCUIT BOARD ASSY;FSW,FRONT PANEL SWITCH
-10	211-1050-00			2	SCREW,MACHINE; 6-32 X 0.312 L,PNH,STL CAD PLT,T15
-11	211-1050-00			7	SCREW,MACHINE; 6-32 X 0.312 L,PNH,STL CAD PLT,T15
-12	174-5256-00			1	CABLE ASSY ELEC: 7P,0.1,1.18IN L,AWG 24,UL1061,87456-5,103958-4, TYCO,3-640441-3,AMP,FOR PWR SW & LEDS
-13	211-1050-00			4	SCREW,MACHINE; 6-32 X 0.312 L,PNH,STL CAD PLT,T15
-14	671-6098-00			1	CIRCUIT BOARD ASSY:LCDA,LCD ADAPTER
-15	174-5254-00			1	CABLE ASSY ELEC: 2X5P,0.1,19.7 IN L,AWG 24,W/KEYING PLUG,87456-5, 87809-1 CONTACT,AMP
-16	174-5161-00			1	CABLE ASSY;DISPLAY ADAPTER TO PCI BOARD
-17	129-1631-00			2	LOCKING STANDOFF; NATURAL 3/8 IN. SPACER,NYLON 66,1M/BAG TOP/BOTTOM HOLES: 156 IN. /.187 IN. TOP/BOTTOM PANEL THK: .062 IN.;
-18	671-6063-00			1	CIRCUIT BOARD ASSY;FRONTPANEL 389377400 WIRED
-19	260-2819-00			1	SWITCH,KEYPAD; FRONT PANEL 4CH; AWG7000 SERIES
-20	407-5176-00			1	BRACKET;TRIM,FRONTPANEL,SHEET METAL,SAFETY CONTROLLED
-21	174-4791-00			1	CA ASSY; DISPLAY ADAPTER TO XGA DISPLAY,SAFETY CONTROLLED
-22	211-1050-00			2	SCREW,MACHINE; 6-32 X 0.312 L,PNH,STL CAD PLT,T15

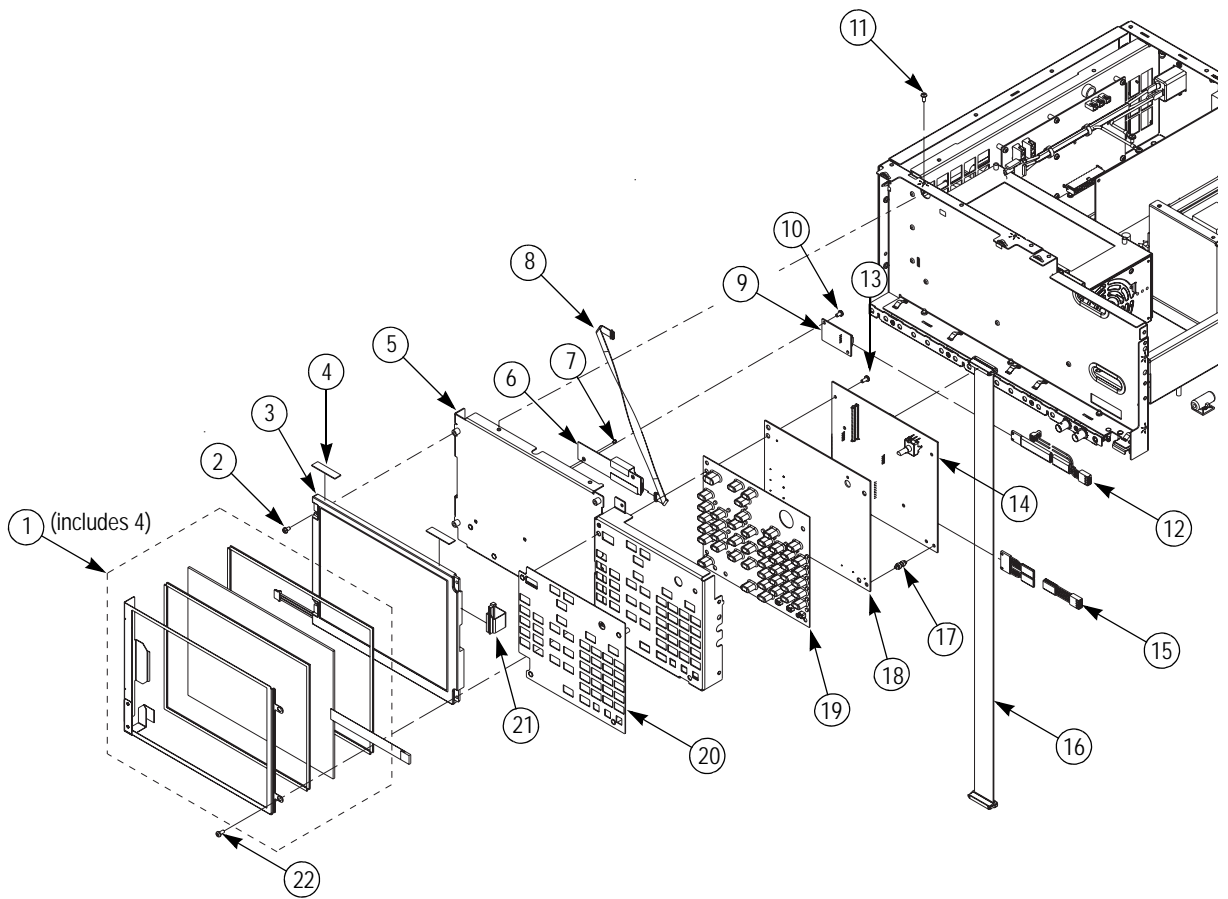

Figure 5-4: Exploded diagram - Front-panel assembly

Replaceable parts list

Fig. & index number	Tektronix part number	Serial no. effective	Serial no. dis-cont'd	Qty	Name & description
5-5					DRIVE MODULE
-1	407-5156-00			1	BRACKET,DVD-CD/RW;ADAPTER FOR DVD-CD/RW SLIMLINE
-2	211-1050-00			5	SCREW,MACHINE; 6-32 X 0.312 L,PNH,STL CAD PLT,T15
-3	211-0950-00			4	SCREW,MACHINE; M2X.4X3L,PHL, PNH, STL NI PL
-4	065-0666-02			1	DISK DRIVE; OPTICAL; CDRW/DVDROM / TEAC
-5	129-1618-00			1	SPACER; DVD-CD/RW SLIMLINE DRIVE ADAPTER,PLASTIC
-6	671-5915-00			1	CKT BD SUBASSY; DVD-CD/RW ADAPTER,UNTESTED,389-3689-00 WIRED
-7	211-0888-00			2	SCREW,METRIC; M-2 X 0.4 X 6MM,PHILLIPS PAN,ZINC PLATED,PHIL PAN HEAD,STEEL
-8	174-4671-00			1	CA ASSY,SP; ULTRA DMA/ATA HARD DISK DRIVE,IDE,18.0 L,SAFETY CONTROLLED
-9	211-1050-00			8	SCREW,MACHINE; 6-32 X 0.312 L,PNH,STL CAD PLT,T15
-10	441-2474-00			1	CHASSIS,DRIVE BAY;METAL
-11	407-5069-00			1	BRACKET,RHDD; SATA COMBO CABLE,3.5 INCH REMOVABLE HARD DISK DRIVE RECEPTACLE
-12	211-1050-00			5	SCREW,MACHINE; 6-32 X 0.312 L,PNH,STL CAD PLT,T15
-13	174-5169-00			1	CABLE ASSY; SATA COMBO,HARD DRIVE CABLE
-14	119-7189-00			1	DISK DRIVE,HARD; 80GB,3.5 INCH,7200 RPM,SATA II 3.0 GB/S INTERFACE, HITACHI P/N HDS728080PLA380,PATHFINDER 0A30358, SAFETY CONTROLLED
-15	351-1118-00			1	GUIDE,HD; REMOVABLE,3.5 INCH HARD DISK DRIVE, SAFETY CONTROLLED
-16	211-1174-00			4	SCREW,MACHINE; W/HEAVY PATCH THREADLOCKING MATERIAL; 6-32 X 0.312 L,PNH,STL CAD PLT,T15
-17	407-5172-00			1	BRACKET, ASSEMBLY, REMOVABLE 3.5 INCH HARD DRIVE CARTRIDGE, AWG7000 SERIES
-18	211-0734-00			4	SCREW,MACHINE; 6-32 X 0.250,FLH100,STL,CDPL,T-10 TORX DR
-19	174-5017-00			1	CABLE ASSEMBLY; DVD POWER, SAFETY CONTROLLED
-20	065-0753-00			1	ACCESSORY KIT; REMOVABLE HDD ASSY; UNPROGRAMMED HARD DRIVE 119718900 W/PACKAGING

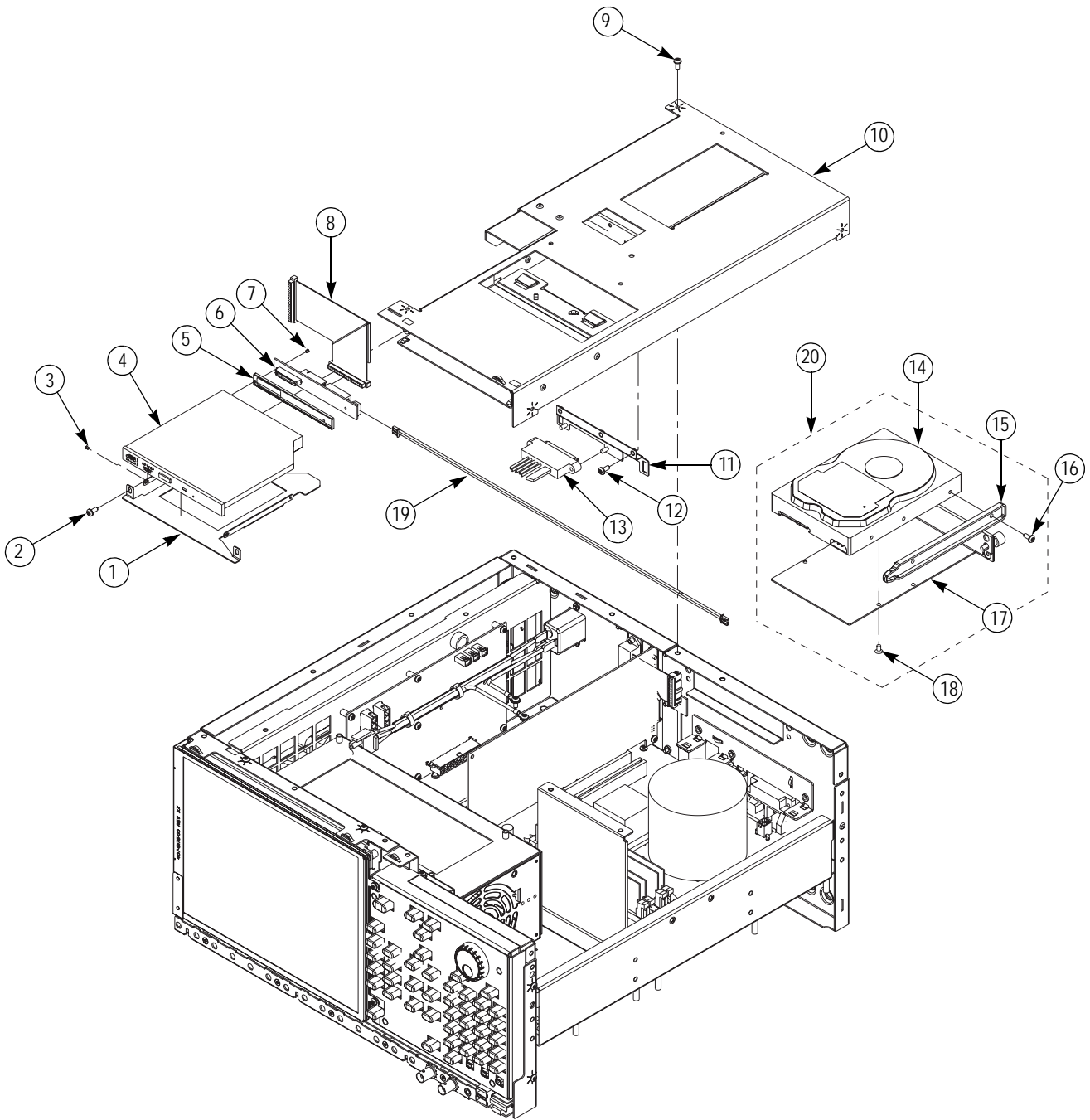

Figure 5-5: Exploded diagram - Drive module

Replaceable parts list

Fig. & index number	Tektronix part number	Serial no. effective	Serial no. discont'd	Qty	Name & description
5-6					PROCESSOR MODULE
-1	407-5195-00			1	BRACKET;DRIVE BAY UNIT
-2	211-1050-00			10	SCREW,MACHINE; 6-32 X 0.312 L,PNH,STL CAD PLT,T15
-3	346-0128-00			2	STRAP,TIEDOWN;8.0 L X 0.1 W,NYLON
-4	343-1701-00			2	CLAMP,CABLE; WITH ADHESIVE BACK
-5	211-1050-00			8	SCREW,MACHINE; 6-32 X 0.312 L,PNH,STL CAD PLT,T15
-6	167-0428-00			1	IC,MEMORY;64M X 64,512 MB DDR2,1.8V,3-3-3;MT16HTF6464AY-40E,DIMM240,DS1
-7	214-5119-00			1	HEAT SINK,SEMIC; IC,PROCESSOR;ALUMINUM WITH 12V FAN FOR INTEL PENTIUM 4 PROCESSOR,FOR LGA775 PACKAGE USE;COOLER MASTER S3N-9IWLS-06-GP, SAFETY CONTROLLED
-8	167-0543-00			1	PROCESSOR; CELERON D,2.93 GHZ,1.287V TO 1.4V CORE,84W,BUS SPD 533MHZ, FC-LGA4 775 PKG,W/O FAN&HEATSINK,JM80547RE077CN,INTEL
-9	335-1259-00			1	MARKER,IDENT;MKD MAC ADDRESS LABEL
-10	342-1153-00			1	INSULATOR; PLATE,MOTHER BOARD,0.04 POLYCARBONATE,TAPPEN
-11	441-2484-00			1	CHASSIS,TRAY,PROCESSOR,TAPPEN, SAFETY CONTROLLED
-12	407-5205-00			1	BRACKET,CONN; AL,0.063 THICK,W/131641700 EMI CLIPS
-13	211-1050-00			3	SCREW,MACHINE; 6-32 X 0.312 L,PNH,STL CAD PLT,T15
-14	214-3903-00			6	SCREW,JACK; 4-40 X 0.312 LONG,0.188 H HEX HEAD STAND OFF,4-40 INT THD, X 0.312 THD EXT 4-40
-15	065-0761-00			1	MODULE; PROCESSOR

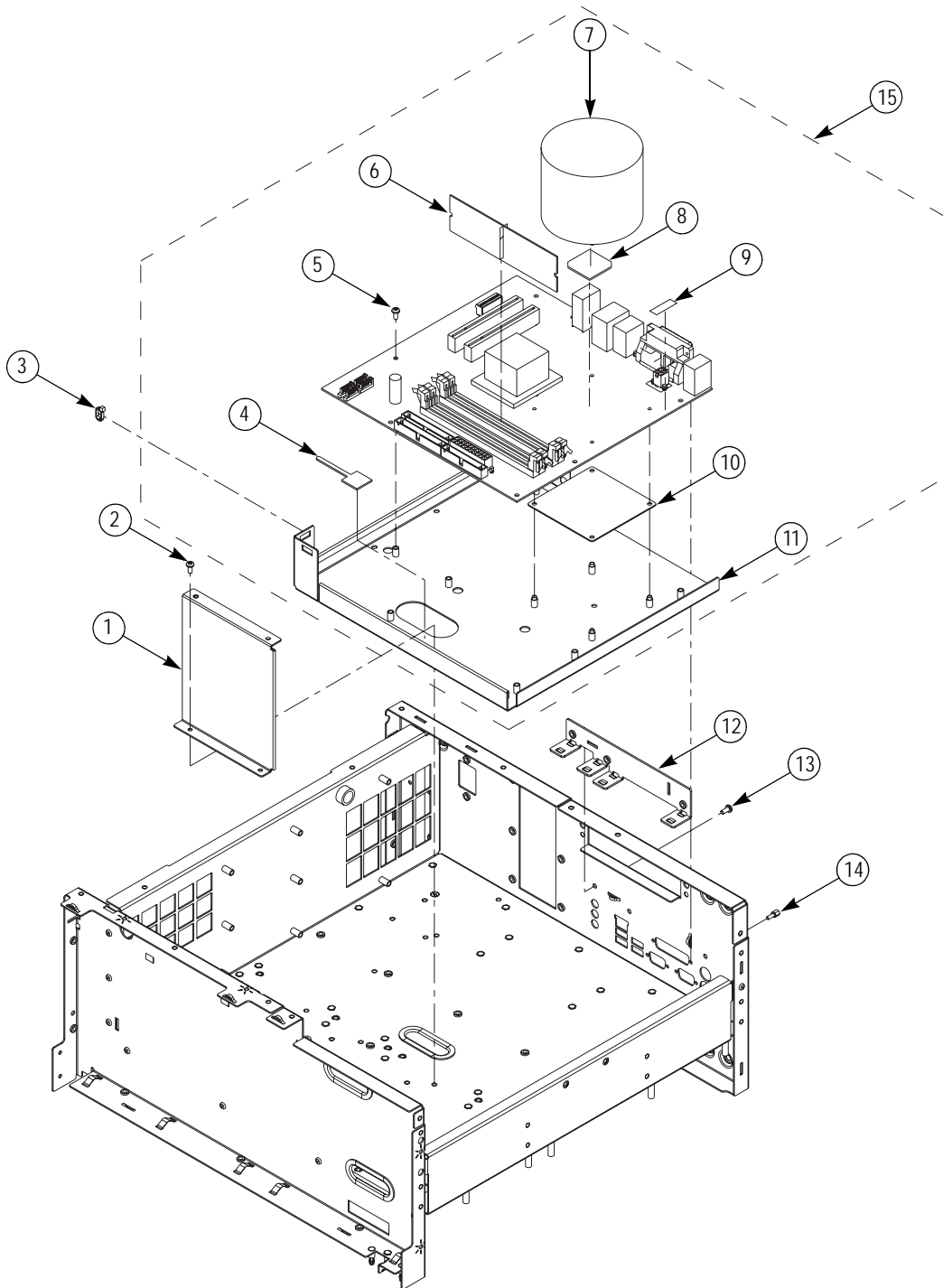

Figure 5-6: Exploded diagram - Processor module

Replaceable parts list

Fig. & index number	Tektronix part number	Serial no. effective	Serial no. dis-cont'd	Qty	Name & description
5-7					POWER SUPPLY ASSEMBLY
-1	119-6986-00			1	POWER SUPPLY; AC-DC;460W;+3.3V 40A,+5V 34A,+12V 25A,-12V 1A,+5VSB 2A;90-264VAC,47-63HZ;BERG 51624-XX001;9.5X4.9X3.8IN,SAFETY CONTROLLED
-2	211-1050-00			6	SCREW,MACHINE; 6-32 X 0.312 L,PNH,STL CAD PLT,T15
-3	407-5145-00			1	BRACKET, POWER SUPPLY
-4	211-1050-00			3	SCREW,MACHINE; 6-32 X 0.312 L,PNH,STL CAD PLT,T15
-5	174-5269-00			1	CABLE ASSY; AC INLET TO CKT BD,14 IN L,AWG16 X 3,W/FN9222-10/06 FILTER/1-480700 CONN
-6	211-1050-00			4	SCREW,MACHINE; 6-32 X 0.312 L,PNH,STL CAD PLT,T15

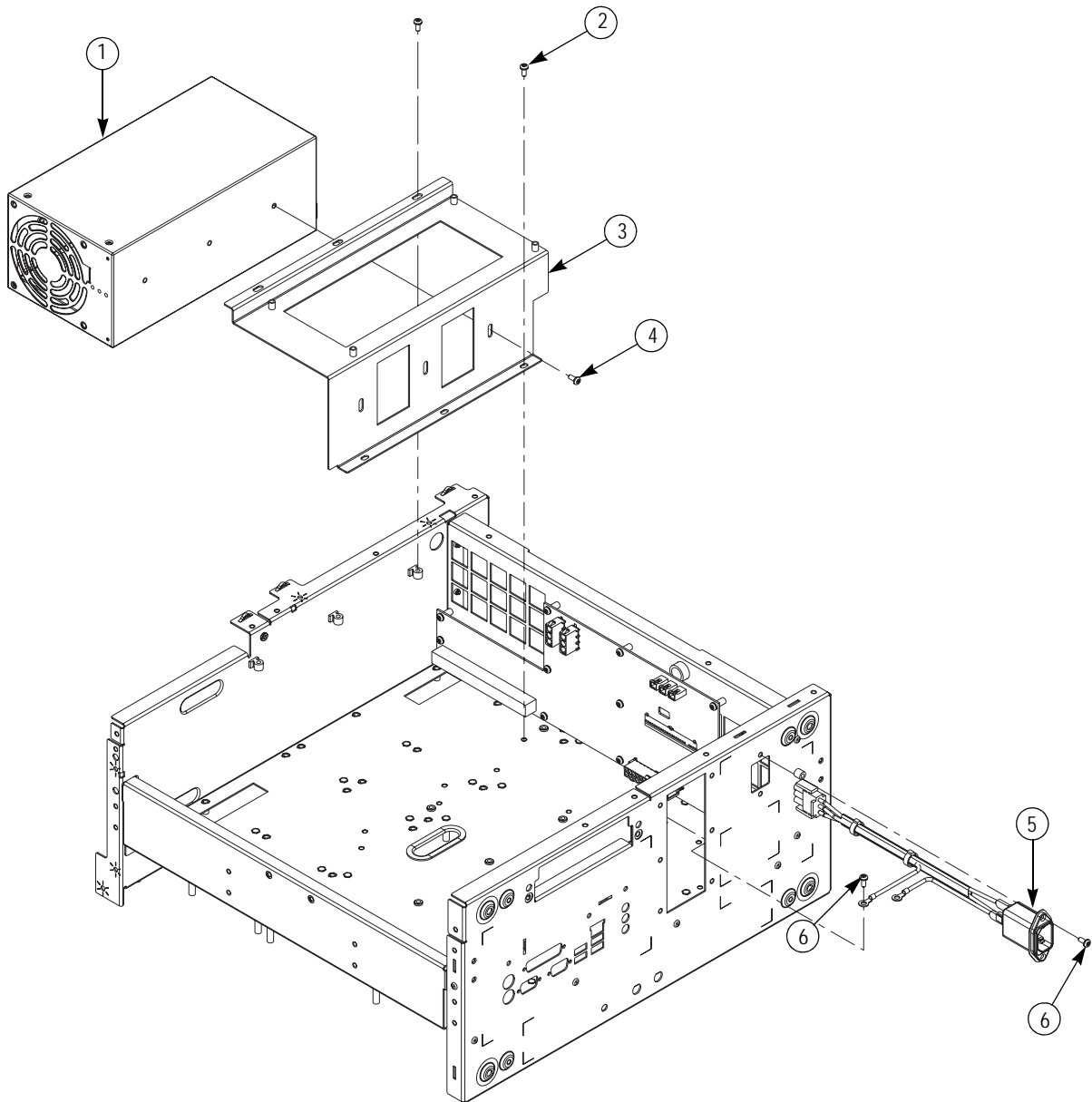

Figure 5-7: Exploded diagram - Power supply assembly

Replaceable parts list

Fig. & index number	Tektronix part number	Serial no. effective	Serial no. discont'd	Qty	Name & description
5-8					PCI/POWER INTERFACE MODULE
-1	174-5246-00			1	CABLE ASSY ELEC: 2 X 12P,31IN L,AWG16 X 24,39-01-2245,39-01-2245, MOLEX
-2	174-4798-00			1	CABLE ASSEMBLY; 4 PIN P4 POWER,SAFETY CONTROLLED
-3	174-4797-00			1	CABLE ASSEMBLY; 20 PIN ATX POWER,SAFETY CONTROLLED
-4	174-5255-00			1	CABLE ASSY ELEC: 2P,0.1,11.8IN L,AWG 22,UL1430,22-01-3027,08-50-0114 CONTACT, MOLEX
-5	211-1050-00			10	SCREW,MACHINE; 6-32 X 0.312 L,PNH,STL CAD PLT,T15
-6	671-6064-00			1	CIRCUIT BOARD ASSY; POWER DC-DC, 389-3775-00
-7	343-1701-00			1	CLAMP,CABLE; WITH ADHESIVE BACK
-8	335-1663-00			1	MARKER, IDENT; LABEL, COSMETIC, REAR, LEXAN
-9	335-0347-00				MARKER,IDENT; REAR PANEL,BLANK,2.100 X 2.700,SAFETY CONTROLLED
-10	174-5245-00			1	CABLE ASSY ELEC: FLAT CABLE,TWISTED PAIR,68P,0.05 PITCH,20IN L, SDA-71660-3568,MOLEX
-11	174-5307-00			1	CABLE ASSY ELEC: GPIB,5INL,BOARD TO REAR PANEL,24P GPIB CONN TO 24P HEADER CONN,W/O JACK SCREW, SAFETY CONTROLLED
-12	335-1668-00			1	MARKER,IDENT; LABEL, I/O FOR PCI PCB (ATTACHES TO PCI PCB BRACKET), SAFETY CONTROLLED
-13	211-1050-00			6	SCREW,MACHINE; 6-32 X 0.312 L,PNH,STL CAD PLT,T15
-14	213-1061-00			2	JACKSCREW; 6-32 X 0.320 EXT THD,M3.5 X 0.6-6 INT THD X 0.215L,GPIB, BLACK OXIDE, BULK PACK
-15	211-1206-00			2	SCREW,JACK; 2-56 ID X 4-40 OD,0.188 HEX,SS
-16	386-7462-00			1	BRACKET, REAR: MIO
-17	211-1050-00			1	SCREW,MACHINE; 6-32 X 0.312 L,PNH,STL CAD PLT,T15
-18	671-6049-00			1	CIRCUIT BOARD ASSY; MIO MULTI-I/O, FR-4
-19	335-1663-00			1	MARKER,IDENT; LABEL,COSMETIC,REAR,AWG,LEXAN (AWG7xx1)
	335-1664-00			1	MARKER,IDENT; LABEL,COSMETIC,REAR,AWG,LEXAN (AWG7xx2)
-20	335-1662-00			1	MARKER,IDENT; LABEL,REAR I/O,MAIN,LEXAN, SAFETY CONTROLLED

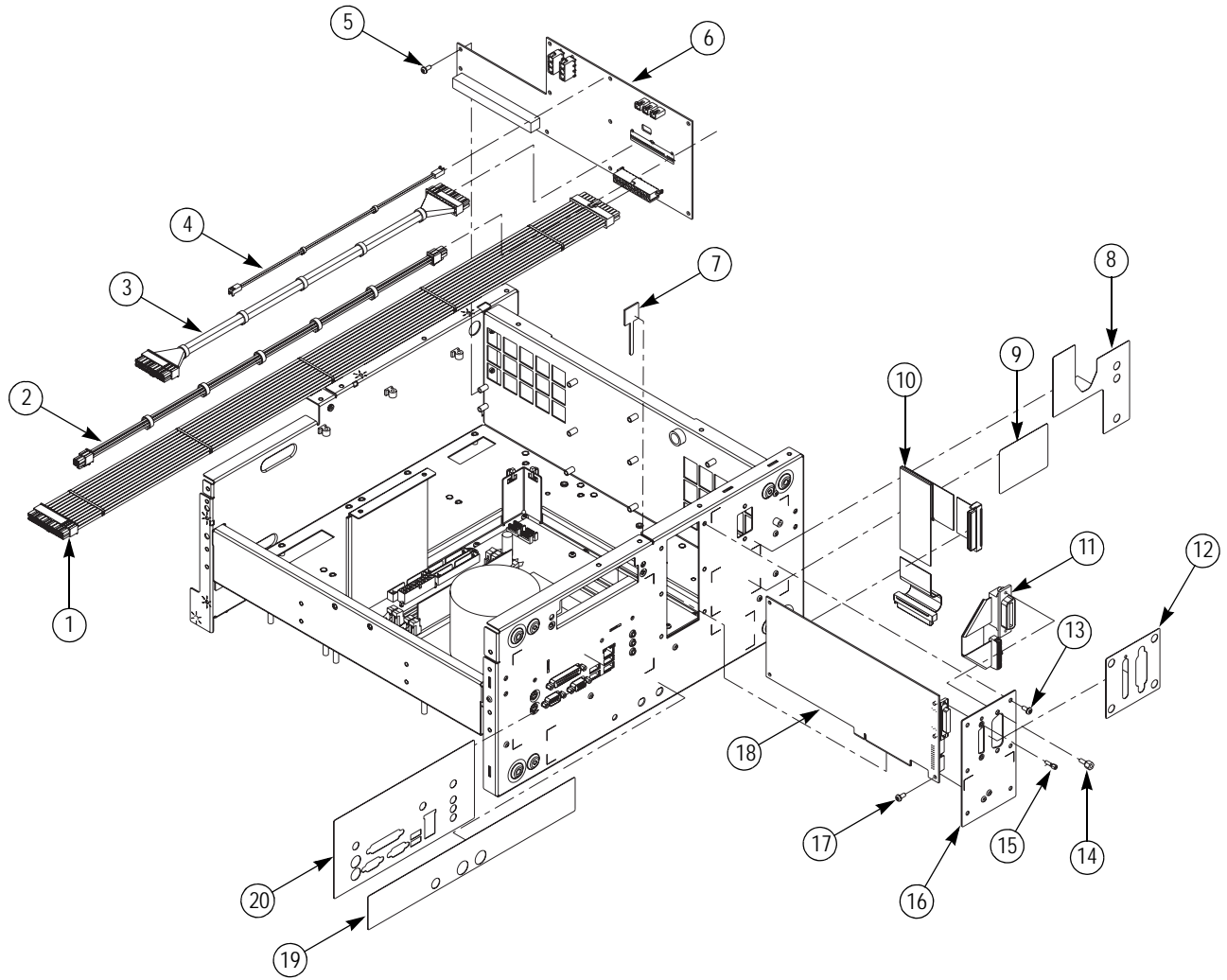

Figure 5-8: Exploded diagram - PCI/power interface module

Replaceable parts list

Fig. & index number	Tektronix part number	Serial no. effective	Serial no. discont'd	Qty	Name & description
5-9					FAN TRAY ASSEMBLY
-1	211-1050-00			4	SCREW,MACHINE; 6-32 X 0.312 L,PNH,STL CAD PLT,T15
-2	211-1213-01			12	SCREW, METRIC 5 X 10MM, FLATHEAD, STL, ZINC, POSI
-3	407-5170-00			1	BRACKET,FAN TRAY
-4	343-0549-00			2	STRAP,TIEDOWN; 0.098 W X 4.0 L, ZYTEL
-5	119-7182-00			3	FAN,TUBEAXIAL; 12VDC,0.40A,4.80W,2500RPM,100.6CFM,120MM,LEADS W/CONN; SAFETY CONTROLLED

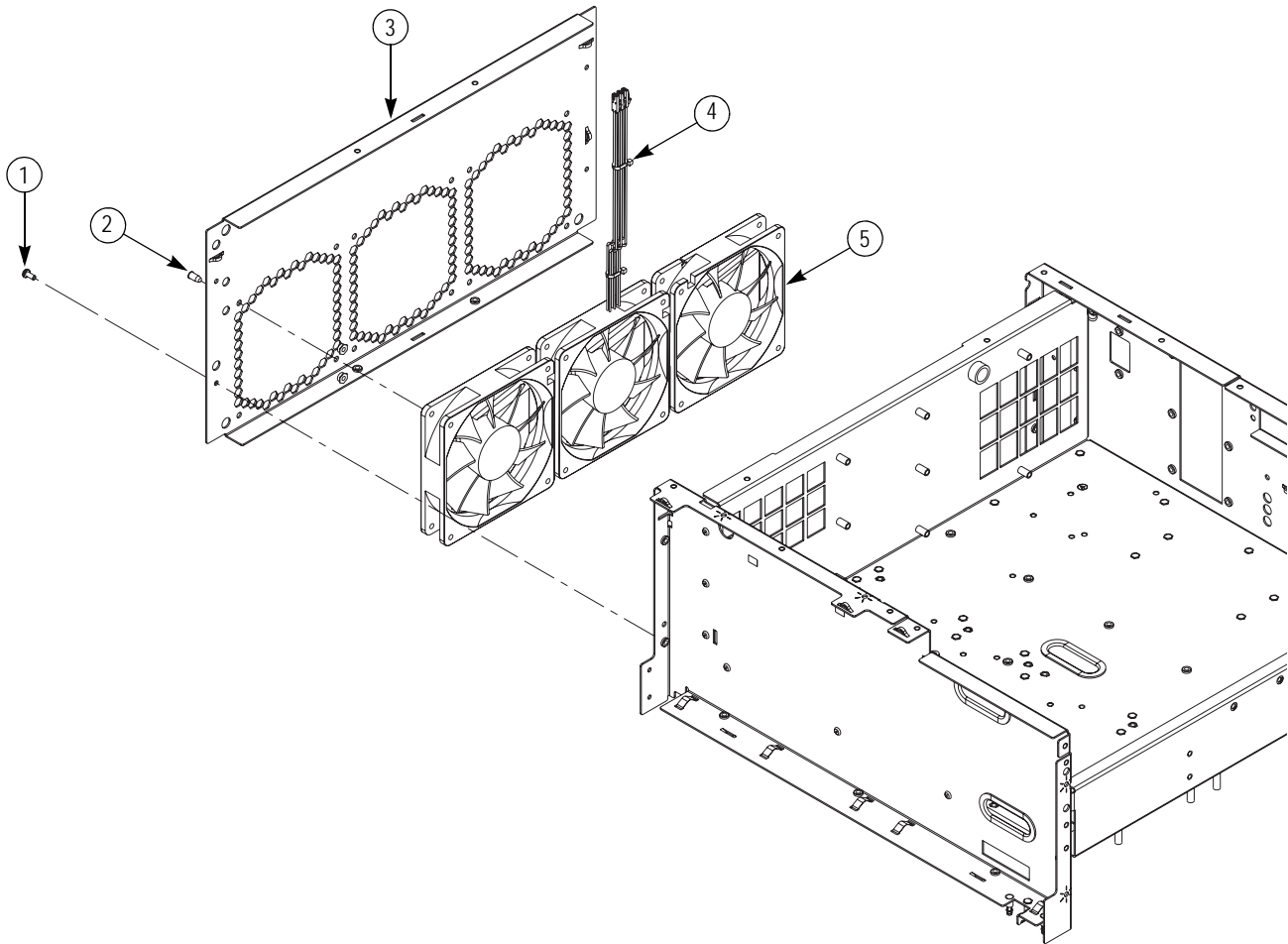

Figure 5-9: Exploded diagram - Fan tray assembly

Replaceable parts list

Fig. & index number	Tektronix part number	Serial no. effective	Serial no. discont'd	Qty	Name & description
5-10					USB MODULE
-1	211-1050-00			2	SCREW,MACHINE; 6-32 X 0.312 L,PNH,STL CAD PLT,T15
-2	671-6150-00			1	CIRCUIT BOARD ASSY; FCON, FRONT PANEL CONNECTOR
-3	174-5233-00			1	CA ASSY,INTCON; CMPST,USB2.0,24/28 AWG,24 IN L,10 POS,1 X 10 AND 2 X 5,USB2.0 CABLE X 2,0.1 CTR
-4	174-5248-00			1	CABLE ASSY ELEC: 1 X 8P,FLAT,0.1,16.8IN L,AWG 26,103958-7 AMP

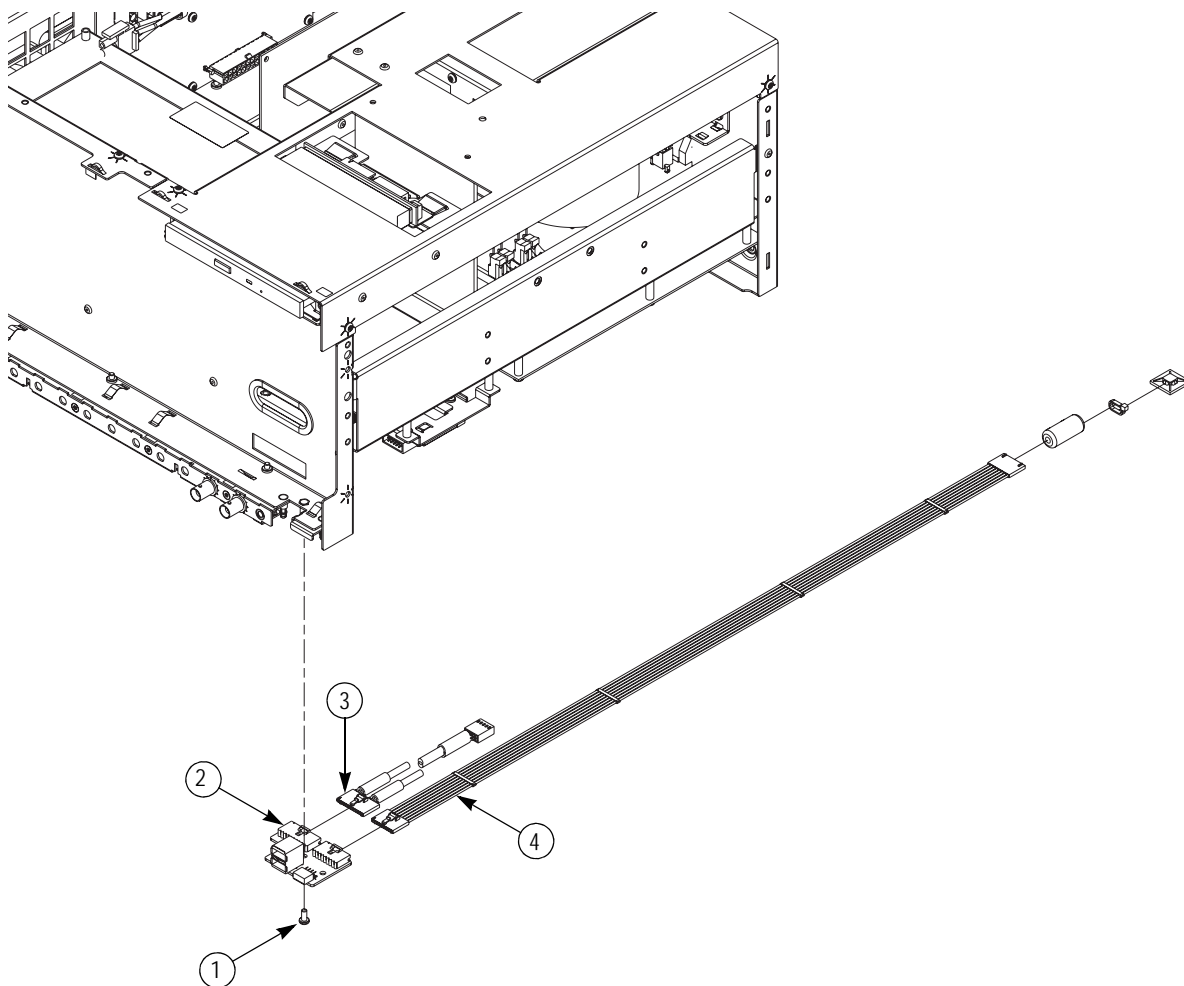

Figure 5-10: Exploded diagram - USB module

Replaceable Parts List

Fig. & index number	Tektronix part number	Model	Serial no. effective	Serial no. discont'd	Qty	Name & description
5-11						AWG10G/CLK10G/OUT10G MODULES
-1	211-1050-00				11	SCREW,MACHINE; 6-32 X 0.312 L,PNH,STL CAD PLT,T15
-2	210-0586-00	AWG7xx1			8	NUT,PL,ASSY WA; 4-40 X 0.25,STL CD PL
	210-0586-00	AWG7xx2			16	NUT,PL,ASSY WA; 4-40 X 0.25,STL CD PL
-3	214-5120-00	AWG7xx1			2	HEAT SINK,SEMIC; IC,FLAT PKG,BLOCK,OUT10G,ALPHA T40-6B MACHINED, 40 X 40 X 6MM,USED W/407520600 & 348188300
	214-5120-00	AWG7xx2			4	HEAT SINK,SEMIC; IC,FLAT PKG,BLOCK,OUT10G,ALPHA T40-6B MACHINED, 40 X 40 X 6MM,USED W/407520600 & 348188300
-4	407-5206-00	AWG7xx1			1	BRACKET HEATSK; OUT10G,0.05,AL,USED W/214512000 & 348188300
	407-5206-00	AWG7xx2			2	BRACKET HEATSK; OUT10G,0.05,AL,USED W/214512000 & 348188300
-5	342-1157-00	AWG7xx1			1	INSULATOR; THERMAL CONDUCTIVE SHEET,0.070 G580, 1.850 X 3.250
	342-1157-00	AWG7xx2			2	INSULATOR; THERMAL CONDUCTIVE SHEET,0.070 G580, 1.850 X 3.250
-6	211-1050-00	AWG7xx1			9	SCREW,MACHINE; 6-32 X 0.312 L,PNH,STL CAD PLT,T15
	211-1050-00	AWG7xx2			18	SCREW,MACHINE; 6-32 X 0.312 L,PNH,STL CAD PLT,T15
-7	211-1050-00				12	SCREW,MACHINE; 6-32 X 0.312 L,PNH,STL CAD PLT,T15
-8	348-1887-00	AWG7xx1			1	GASKET,ELEC;CONDUCTIVE URETHANE FORM 0.158X0.236X0.400, W/ADHESIVE,LAIRD #4704
	348-1887-00	AWG7xx2			2	GASKET,ELEC;CONDUCTIVE URETHANE FORM 0.158X0.236X0.400, W/ADHESIVE,LAIRD #4704
-9	348-1886-00	AWG7xx1			1	GASKET,ELEC;CONDUCTIVE URETHANE FORM 0.158X0.236X1.000, W/ADHESIVE,LAIRD #4704
	348-1886-00	AWG7xx2			2	GASKET,ELEC;CONDUCTIVE URETHANE FORM 0.158X0.236X1.000, W/ADHESIVE,LAIRD #4704
-10	348-1888-00				1	ABSORBER,RF: 3.050X0.800X0.079,W/ADHESIVE,TDK IRB02A2
-11	348-1885-00	AWG7xx1			2	GASKET,ELEC;CONDUCTIVE URETHANE FORM 0.080X1.345X3.050, W/ADHESIVE, LAIRD #4315
	348-1885-00	AWG7xx2			4	GASKET,ELEC;CONDUCTIVE URETHANE FORM 0.080X1.345X3.050, W/ADHESIVE, LAIRD #4315
-12	337-4397-00	AWG7xx1			1	BRACKET; SHIELD,COVER,OUT10G BD
	337-4397-00	AWG7xx2			2	BRACKET; SHIELD,COVER,OUT10G BD
-13	211-1050-00				10	SCREW,MACHINE; 6-32 X 0.312 L,PNH,STL CAD PLT,T15
-14	211-0691-00				4	SCR,ASSEM WSHR; 6-32 X 0.625,PNH,STL,CDPL,T-15 TORX DR, MACHINE
-15	671-6065-00	AWG7xx1			1	CIRCUIT BOARD ASSY; OUTPUT 10GS, STD, 389-3776-00
	671-6065-00	AWG7xx2			2	CIRCUIT BOARD ASSY; OUTPUT 10GS, STD, 389-3776-00
	671-6066-00	AWG7xx1 Option 02			1	CIRCUIT BOARD ASSY; OUTPUT 10GS, OPTION, 389-3777-00
	671-6066-00	AWG7052 Option 02, AWG7102 Option 06			2	CIRCUIT BOARD ASSY; OUTPUT 10GS, OPTION, 389-3777-00
-16	348-1890-00	AWG7xx1			1	ABSORBER: RF,2.950 SQX0.079 THICK,W/ADHESIVE,TDK IRB02A2
	348-1890-00	AWG7xx2			2	ABSORBER: RF,2.950 SQX0.079 THICK,W/ADHESIVE,TDK IRB02A2
-17	348-1889-00				1	ABSORBER,RF: 11.810X0.925X0.079 THICK, W/ADHESIVE,TDK IRB02A2

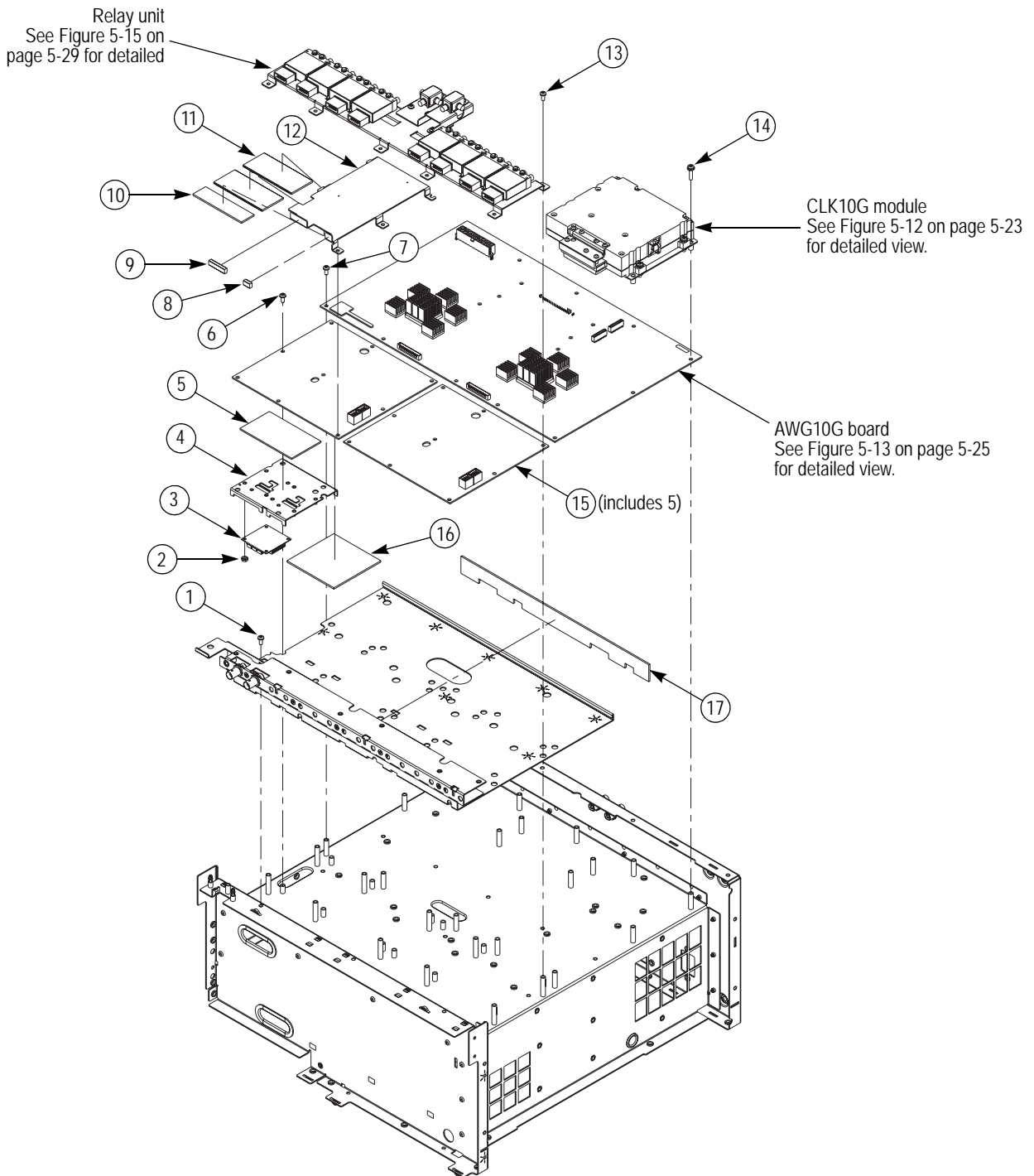

Figure 5-11: Exploded diagram - AWG10G/CLK10G/OUT10G modules

Replaceable Parts List

Fig. & index number	Tektronix part number	Serial no. effective	Serial no. discont'd	Qty	Name & description
5-12					CLK10G MODULE
-1	174-5328-00			1	CABLE ASSY ELEC: RF,COAX,11.8IN L,50 OHM,SMP-R RTANG TO SMP-R RTANG,FLEX COAX CABLE,VSWR 1.35 IL 1.3DB AT 12GHZ
-2	011-0184-00			1	TERMINATION: COAX,50 OHM,+20DBM,SMP,FEMALE,DC-18GHZ,VSWR 1.2 AT 15GHZ 1.25 AT 18GHZ,GOLD W NI UNDERPLATED,P918-1CC, TENSOLITE
-3	211-1235-00			10	SCREW,MACHINE; W/HEAVY PATCH THREADLOCKING MATERIAL; 4-40 X 1.0,PNH,STL CD PLT,T10
-4	337-4397-00			1	BRACKET; SHIELD,COVER,OUT10G BD
-5	211-1237-00			3	SCREW,MACHINE; W/HEAVY PATCH THREADLOCKING MATERIAL; 4-40 X 0.75,PNH, STL CD PLT,T10
-6	211-1236-00			2	SCREW,MACHINE; W/HEAVY PATCH THREADLOCKING MATERIAL; 4-40 X 0.25,PNH, STL CD PLT,T10
-7	352-0482-00			2	HOLDER,CABLE TIE; 0.75 SQ,STICKY BACK,PLASTIC,SAFETY CONTROLLED
-8	343-0549-00			2	HOLDER,CABLE TIE; 0.75 SQ,STICKY BACK,PLASTIC,SAFETY CONTROLLED
-9	337-4383-00			1	SHIELD,ELEC;CASE TOP CLK10G
-10	342-1154-00			1	INSULATOR; THERMAL CONDUCTIVE SHEET,0.04 G974,0.354 X 0.709, CHOMERICS
-11	342-1155-00			1	INSULATOR; THERMAL CONDUCTIVE SHEET,0.04 G974,0.787 X 0.787, CHOMERICS
-12	211-0250-00			2	SCREW,MACHINE; 2-56 X 0.937,FLH,STL CD PL,POZ
-13	119-7247-00			1	YIG OSCILLATOR: 4.7GHZ TO 11.7GHZ,+12V 170MA, -5V 30MA,HEATER +12V 70MA MAX 300MA,OUT +9DBM,HARM -17DBC,NOISE -125DBC/HZ 100KHZ, -154DBC/HZ 5MHZ,W/CABLE, FS2732,TELEDYNE
-14	174-5289-00			1	CABLE ASSY ELEC: RF,COAX,1.7IN L,50 OHM,SMP-R RTANG,SMA-P RTANG, FLEX COAX CABLE
-15	671-6204-00			1	ASSY,OUTSOURCED;3893870XX WIRED,CLK10G
-16	210-0001-00			2	WASHER,LOCK; #2 INTL,0.013 THK,STL CD PL
-17	210-0405-00			2	NUT,PLAIN,HEX; 2-56 X 0.188,BRS CD PL
-18	342-1156-00			1	INSULATOR; THERMAL CONDUCTIVE SHEET,0.04 G974,2.85 X 2.10, CHOMERICS
-19	211-0691-00			4	SCR,ASSEM WSHR; 6-32 X 0.625,PNH,STL,CDPL,T-15 TORX DR,MACHINE
-20	337-4384-00			1	SHIELD,ELEC;CASE BOTTOM CLK10G
-21	407-5190-00			1	BRACKET;SHIELD CASE FOR CLK10G

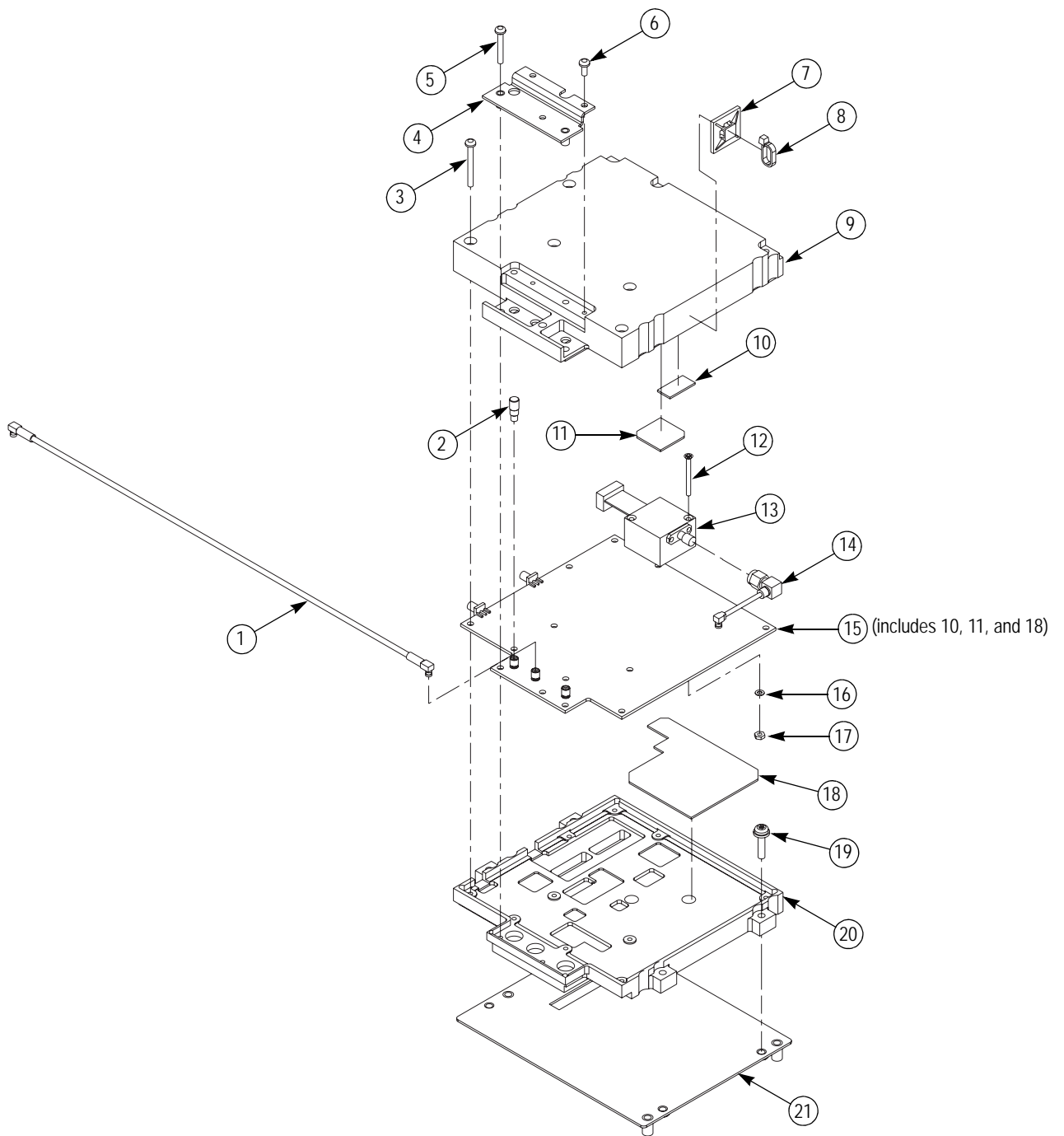

Figure 5-12: Exploded diagram - CLK10G module

Replaceable parts list

Fig. & index number	Tektronix part number	Model	Serial no. effective	Serial no. discontinued	Qty	Name & description
5-13						AWG10G MODULE
-1	352-1114-00				1	HOLDER; CABLE RETENTION SMA,PORON URETHANE, FOR MATCHED PAIR RF CABLE,AWG
-2	174-5341-00	AWG7xx1			2	CABLE ASSY ELEC: RF,COAX,8IN L,50 OHM,SMP-R RTA,SMP-R RTA, W/LABEL, MATCHED DELAY FLEX COAX CABLE
	174-5341-00	AWG7xx2			4	CABLE ASSY ELEC: RF,COAX,8IN L,50 OHM,SMP-R RTA,SMP-R RTA, W/LABEL, MATCHED DELAY FLEX COAX CABLE
-3	174-5340-00	AWG7xx1 Option 02			1	CABLE ASSY ELEC: RF,COAX,8IN L,50 OHM,SMP-R RTA,SMA-P STR, W/LABEL, MATCHED DELAY FLEX COAX CABLE
	174-5340-00	AWG7052 Option 02, AWG7102 Option 06			2	CABLE ASSY ELEC: RF,COAX,8IN L,50 OHM,SMP-R RTA,SMA-P STR, W/LABEL, MATCHED DELAY FLEX COAX CABLE
-4	343-1701-00				1	CLAMP,CABLE; WITH ADHESIVE BACK
-5	174-5342-00	AWG7xx1			1	CABLE ASSY ELEC: RF,COAX,8IN L,50 OHM,SMP-R RTA,SMP-R RTA, W/LABEL, MATCHED DELAY FLEX COAX CABLE
	174-5342-00	AWG7xx2			2	CABLE ASSY ELEC: RF,COAX,8IN L,50 OHM,SMP-R RTA,SMP-R RTA, W/LABEL, MATCHED DELAY FLEX COAX CABLE
-6	174-5249-00	AWG7xx1			1	CABLE ASSY ELEC: 1 X 16P,6.5IN L,AWG24 X 16,PHR-16,PHR-16,JST
	174-5249-00	AWG7xx2			2	CABLE ASSY ELEC: 1 X 16P,6.5IN L,AWG24 X 16,PHR-16,PHR-16,JST
-7	352-0482-00				1	HOLDER,CABLE TIE; 0.75 SQ,STICKY BACK,PLASTIC,SAFETY CONTROLLED
-8	343-0549-00				1	STRAP,TIEDOWN; 0.098 W X 4.0 L, ZYTEL
-9	671-6032-00	AWG7xx1			1	CIRCUIT BOARD ASSY: AWG10G 1CH,389375100 WIRED,LOW ER,L 12
	671-6048-00	AWG7xx2			1	CIRCUIT BOARD ASSY: AWG10G 2CH,389375100 WIRED,LOW ER,L 12

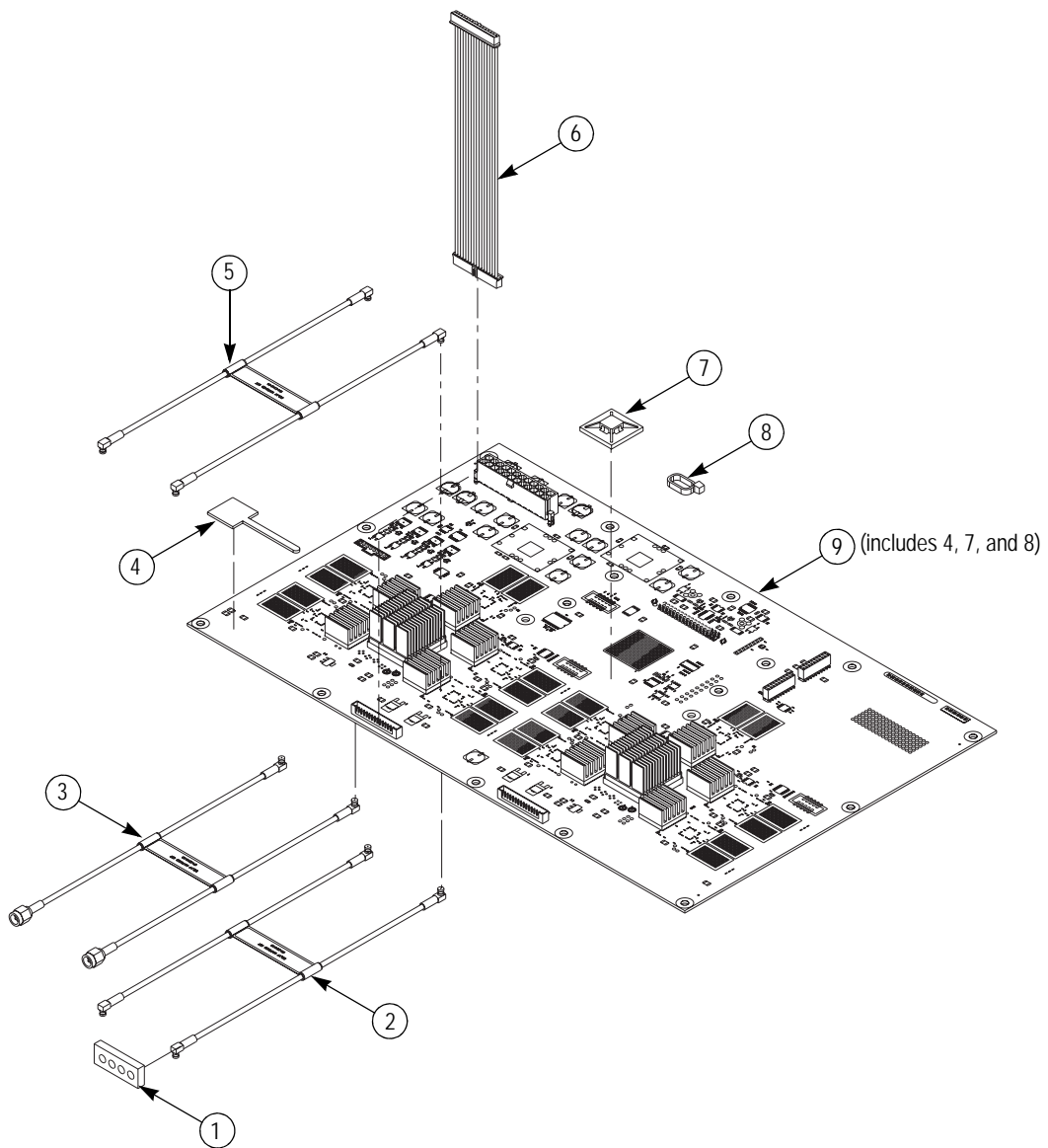

Figure 5-13: Exploded diagram - AWG10G module

Replaceable parts list

Fig. & index number	Tektronix part number	Model	Serial no. effective	Serial no. discont'd	Qty	Name & description
5-14						SMA BRACKET
-1	407-5144-00				1	BRACKET, SMA: FRONT I/O
-2	211-0734-00				5	SCREW,MACHINE; 6-32 X 0.250,FLH100,STL,CDPL,T-10 TORX DR
-3	407-5222-00				1	BRACKET, SMA: FRONT I/O BNC AREA
-4	131-1315-01				2	CONN,RF,JACK; BNC,PNL,50 OHM,FEMALE,STR,PELTOLA/PNL MNT,SILVER ALLOY, 0.576 MLG X 0.366 TERMN,0.375-32 THD,D-FLAT
-5	174-5244-00				2	CABLE ASSY ELEC: RF,COAX,22.8IN L,50 OHM,PELTOLA,PELTOLA,FLEX COAX CABLE
-6	174-5344-00	AWG7xx1			1	CABLE ASSY ELEC: RF,COAX,9.5IN L,50 OHM,SMA-R STR PANEL,SMP-R RTA, W/LABEL,MATCHED DELAY FLEX COAX CABLE
	174-5344-00	AWG7xx2			2	CABLE ASSY ELEC: RF,COAX,9.5IN L,50 OHM,SMA-R STR PANEL,SMP-R RTA, W/LABEL,MATCHED DELAY FLEX COAX CABLE
-7	174-5343-00	AWG7xx1			2	CABLE ASSY ELEC: RF,COAX,7IN L,50 OHM,SMP-R RTA,SMA-R STR, PANEL MOUNT, W/LABEL,MATCHED DELAY FLEX COAX CABLE
	174-5343-00	AWG7xx2			4	CABLE ASSY ELEC: RF,COAX,7IN L,50 OHM,SMP-R RTA,SMA-R STR, PANEL MOUNT, W/LABEL,MATCHED DELAY FLEX COAX CABLE
-8	174-5337-00	AWG7xx1 Option 02			1	CABLE ASSY ELEC: RF,COAX,13.8IN L,50 OHM,SMA-P STR,SMA-R STR, PANEL MOUNT,W/LABEL,MATCHED DELAY FLEX COAX CABLE
	174-5337-00	AWG7052 Option 02			2	CABLE ASSY ELEC: RF,COAX,13.8IN L,50 OHM,SMA-P STR,SMA-R STR, PANEL MOUNT,W/LABEL,MATCHED DELAY FLEX COAX CABLE
	174-5337-00	AWG7102 Option 06			3	CABLE ASSY ELEC: RF,COAX,13.8IN L,50 OHM,SMA-P STR,SMA-R STR, PANEL MOUNT,W/LABEL,MATCHED DELAY FLEX COAX CABLE

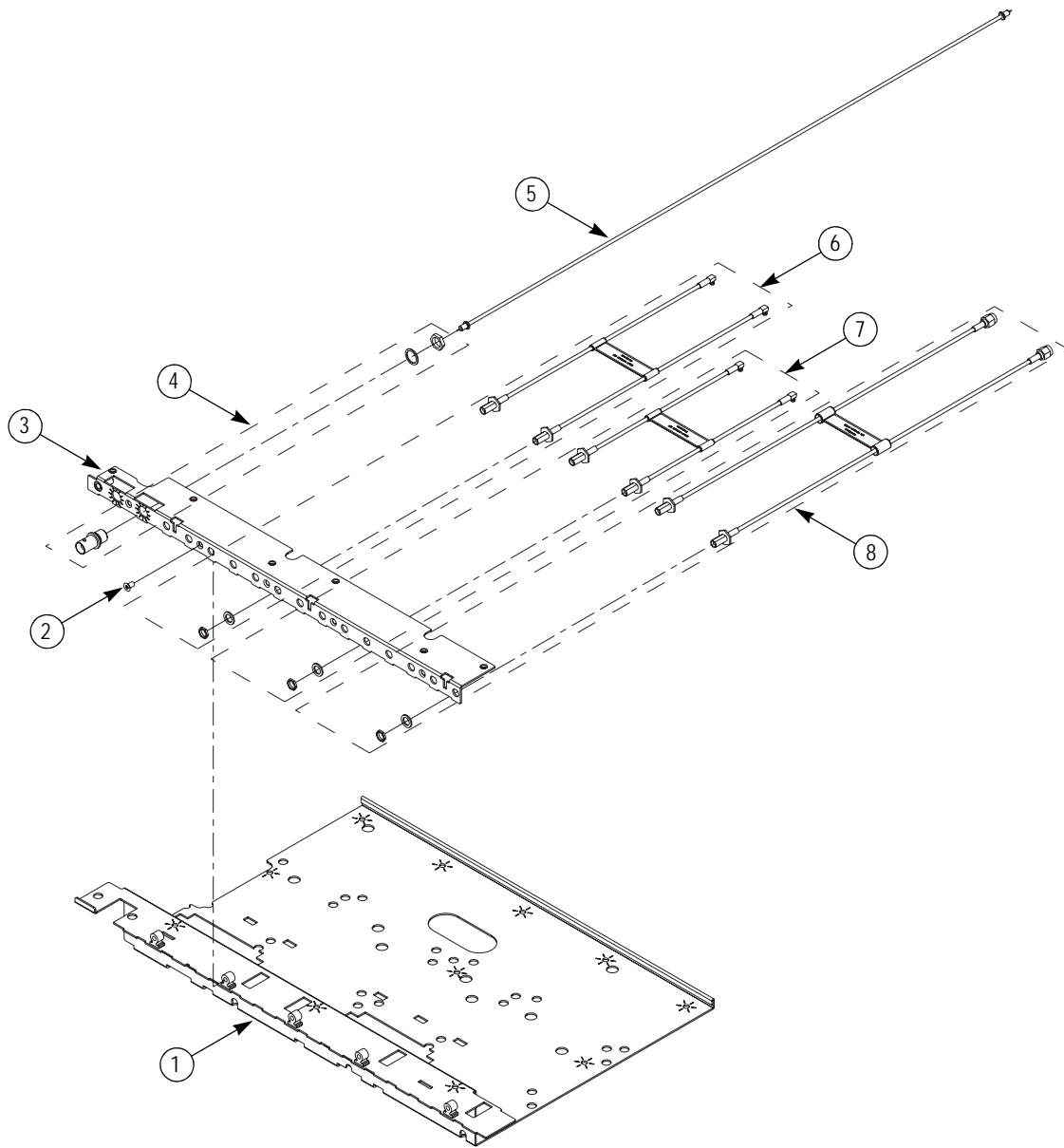

Figure 5-14: Exploded diagram - SMA bracket

Replaceable parts list

Fig. & index number	Tektronix part number	Model	Serial no. effective	Serial no. discont'd	Qty	Name & description
5-15						RELAY UNIT (Option 02/06 only)
-1	174-5258-00	AWG7xx1 Option 02			1	CABLE ASSY ELEC: 10P,0.1,8IN L,3P RIBBON X 2,TYCO & MATSUSHITA, FOR 148033600 RF RELAY
	174-5258-00	AWG7052 Option 02			2	CABLE ASSY ELEC: 10P,0.1,8IN L,3P RIBBON X 2,TYCO & MATSUSHITA, FOR 148033600 RF RELAY
	174-5258-00	AWG7102 Option 06			4	CABLE ASSY ELEC: 10P,0.1,8IN L,3P RIBBON X 2,TYCO & MATSUSHITA, FOR 148033600 RF RELAY
-2	441-2461-00				1	CHASSIS, RELAY UNIT
-3	174-5338-00	AWG7102 Option 06			1	CABLE ASSY ELEC: RF,COAX,4.4IN L,50 OHM,SMA-P STR,SMA-P STR,W/LABEL, MATCHED DELAY FLEX COAX CABLE
-4	211-1050-00	AWG7102 Option 06			4	SCREW,MACHINE; 6-32 X 0.312 L,PNH,STL CAD PLT,T15
-5	343-1715-00	AWG7102 Option 06			2	RETAINER;FOR RF POWER SPLITTER 015072000 1515-1 AEROFLEX/WEINSCHEL INC
-6	015-0720-00	AWG7102 Option 06			2	POWER DIVIDER; 50 OHM,1 WATT,DC TO 18.0 GHZ,SMA FEMALE TO TWO SMA FEMALES,1515-1
-7	407-5198-00	AWG7102 Option 06			1	BRACKET;FOR RF POWER SPLITTER 015072000 1515-1 AEROFLEX/WEINSCHEL INC
-8	211-A273-01	AWG7xx1 Option 02			4	SCREW,MACHINE; M2.5X18 L,PNH,STL,NI PL,CROSS REC,W/FLAT & LOCK WASHER
	211-A273-01	AWG7052 Option 02			8	SCREW,MACHINE; M2.5X18 L,PNH,STL,NI PL,CROSS REC,W/FLAT & LOCK WASHER
	211-A273-01	AWG7102 Option 06			16	SCREW,MACHINE; M2.5X18 L,PNH,STL,NI PL,CROSS REC,W/FLAT & LOCK WASHER
-9	174-5339-00	AWG7102 Option 06			2	CABLE ASSY ELEC: RF,COAX,6IN L,50 OHM,SMA-P STR,SMA-P STR,W/LABEL, MATCHED DELAY FLEX COAX CABLE
-10	174-5250-00	AWG7xx1 Option 02			2	CABLE ASSY ELEC: RF,COAX,10IN L,50 OHM,SMA-P STR,PELTOLA,W/MARK BAND, FLEX COAX CABLE
	174-5250-00	AWG7052 Option 02, AWG7102 Option 06			4	CABLE ASSY ELEC: RF,COAX,10IN L,50 OHM,SMA-P STR,PELTOLA,W/MARK BAND, FLEX COAX CABLE
-11	148-0336-00	AWG7xx1 Option 02			2	PB-FREE;RELAY,ARMATURE; SPDT, SINGLE SIDE STABLE;RF COAXIAL,18GHZ, COIL 12VDC,70MA,1.53H X 1.34W X 0.52D;ARD10012C07,MODULAR,3 SMA CONN,W/10P BOX HEADER
	148-0336-00	AWG7052 Option 02			4	PB-FREE;RELAY,ARMATURE; SPDT, SINGLE SIDE STABLE;RF COAXIAL,18GHZ, COIL 12VDC,70MA,1.53H X 1.34W X 0.52D;ARD10012C07,MODULAR,3 SMA CONN,W/10P BOX HEADER
	148-0336-00	AWG7102 Option 06			8	PB-FREE;RELAY,ARMATURE; SPDT, SINGLE SIDE STABLE;RF COAXIAL,18GHZ, COIL 12VDC,70MA,1.53H X 1.34W X 0.52D;ARD10012C07,MODULAR,3 SMA CONN,W/10P BOX HEADER

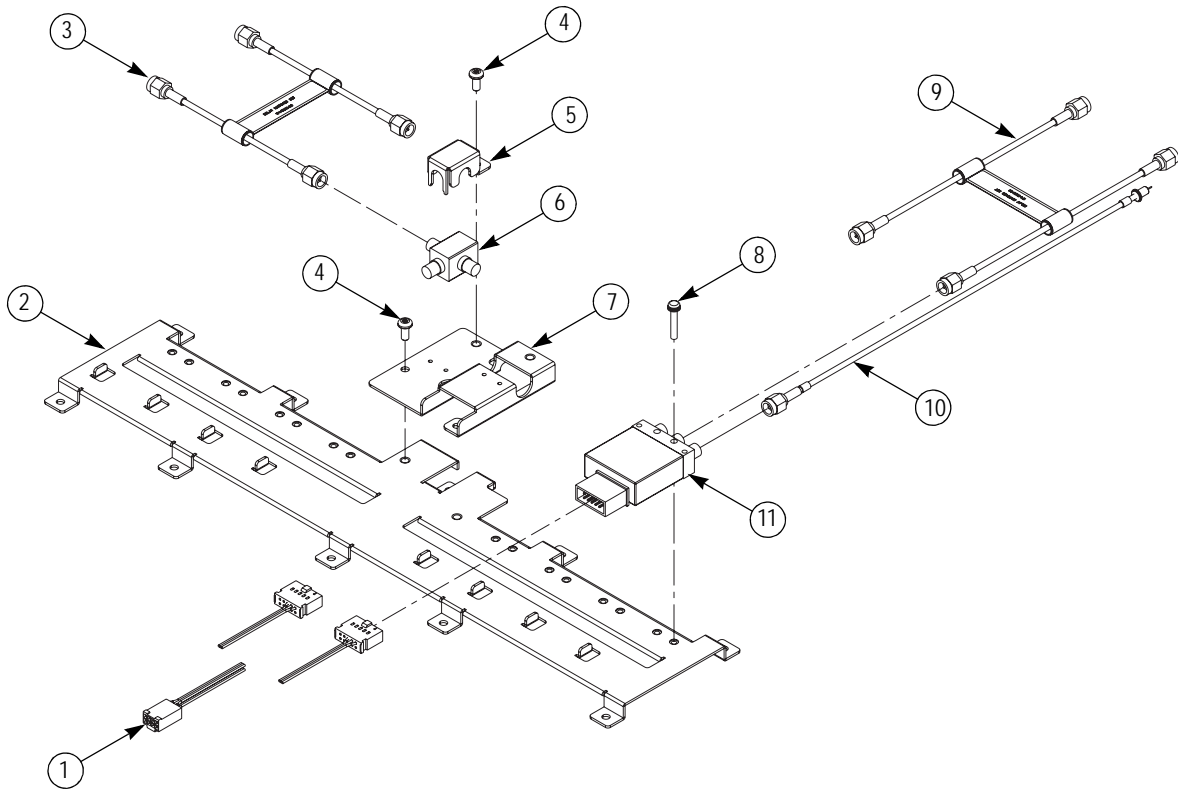

Figure 5-15: Exploded diagram - Relay unit

Replaceable parts list

Fig. & index number	Tektronix part number	Serial no. effective	Serial no. discont'd	Qty	Name & description
5-16					REAR CONNECTORS
-1	174-5323-00			1	CABLE ASSY ELEC: RF,COAX,50 OHM,9.5IN L,SMA-R STR PANEL MOUNT TO SMP-R RTANG,FLEX COAX CABLE
-2	131-1315-01			2	CONN,RF,JACK; BNC,PNL,50 OHM,FEMALE,STR,PELTOLA/PNL MNT, SILVER ALLOY, 0.576 MLG X 0.366 TERMN,0.375-32 THD,D-FLAT
-3	174-5294-00			2	CABLE ASSY ELEC: RF,COAX,7IN L,50 OHM,SMA-P STR,PELTOLA,FLEX COAX CABLE

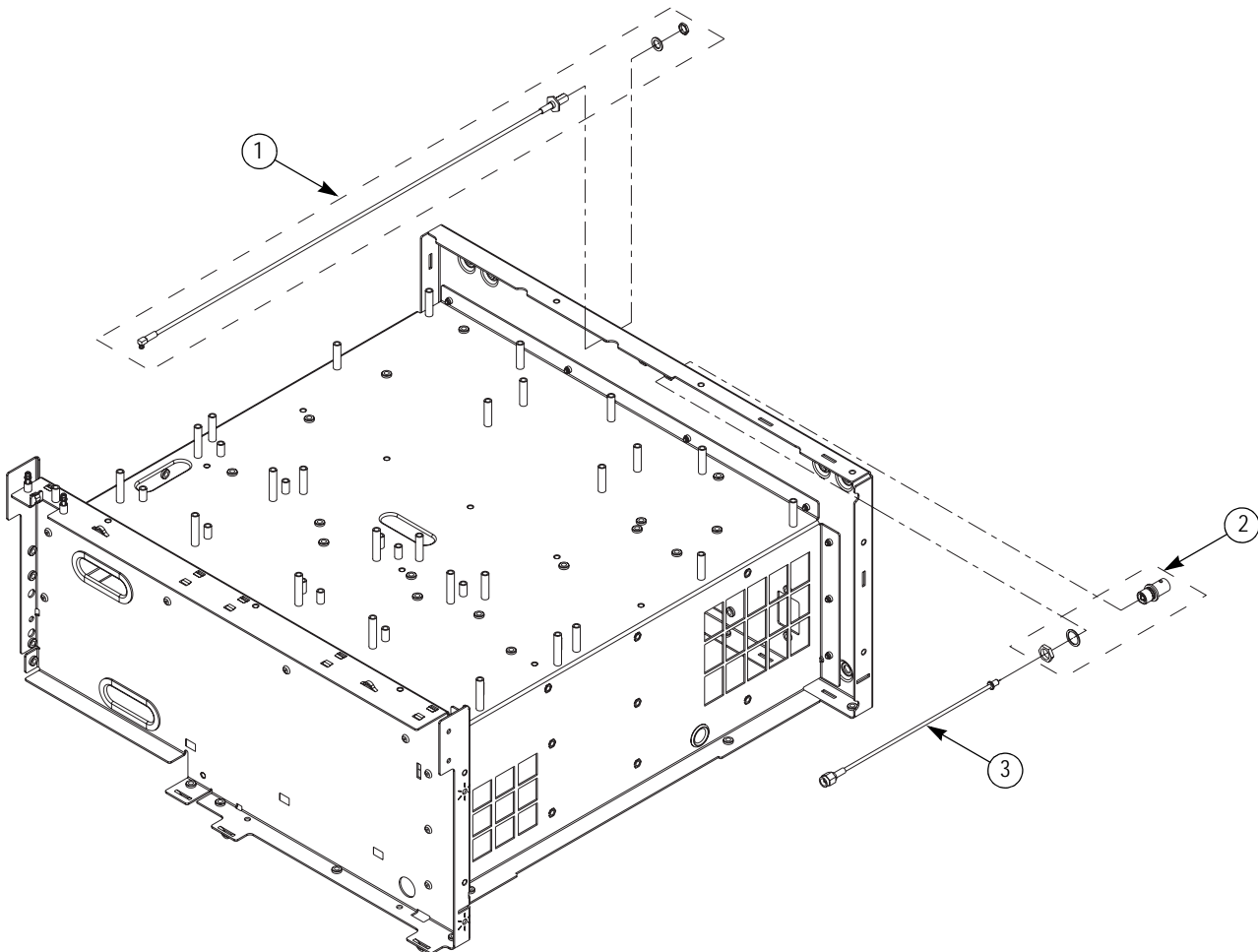

Figure 5-16: Exploded diagram - Rear connectors